

Modicon X80

Analog Input/Output Modules

User Manual

07/2018

The information provided in this documentation contains general descriptions and/or technical characteristics of the performance of the products contained herein. This documentation is not intended as a substitute for and is not to be used for determining suitability or reliability of these products for specific user applications. It is the duty of any such user or integrator to perform the appropriate and complete risk analysis, evaluation and testing of the products with respect to the relevant specific application or use thereof. Neither Schneider Electric nor any of its affiliates or subsidiaries shall be responsible or liable for misuse of the information contained herein. If you have any suggestions for improvements or amendments or have found errors in this publication, please notify us.

You agree not to reproduce, other than for your own personal, noncommercial use, all or part of this document on any medium whatsoever without permission of Schneider Electric, given in writing. You also agree not to establish any hypertext links to this document or its content. Schneider Electric does not grant any right or license for the personal and noncommercial use of the document or its content, except for a non-exclusive license to consult it on an "as is" basis, at your own risk. All other rights are reserved.

All pertinent state, regional, and local safety regulations must be observed when installing and using this product. For reasons of safety and to help ensure compliance with documented system data, only the manufacturer should perform repairs to components.

When devices are used for applications with technical safety requirements, the relevant instructions must be followed.

Failure to use Schneider Electric software or approved software with our hardware products may result in injury, harm, or improper operating results.

Failure to observe this information can result in injury or equipment damage.

© 2018 Schneider Electric. All Rights Reserved.

Table of Contents



	Safety Information	9
	About the Book	13
Part I	Physical Implementation of Analog Modules	17
Chapter 1	General Rules for the Physical Implementation of Analog Modules	19
	Installing Analog Input/Output Modules	20
	Fitting a 20-Pin Terminal Block to an Analog Module	23
	Fitting a 28-Pin Terminal Block to an Analog Module	28
	20-Pin Terminal Block Modules	31
	How to Connect Analog Input/Output Modules: Connecting 20-pin Terminal Block Modules	35
	28-Pin Terminal Blocks	39
	How to Connect Analog Input/Output Modules: Connecting 28-pin Terminal Block Modules	44
	How to Connect Analog Input/Output Modules: Connecting 40-pin Connector Modules	47
	Shielding Connection Kit	50
	TELEFAST Wiring Accessories Dedicated to Analog Modules	53
Chapter 2	Diagnostics for Analog Modules	55
	Display of Analog Module States	56
	Analog Module Diagnostics	57
Chapter 3	BMX AMI 0410 Analog Input Module	59
	Presentation	60
	Standards and Certifications	61
	Characteristics	62
	Functional Description	64
	Wiring Precautions	71
	Wiring Diagram	75
	Use of the TELEFAST ABE-7CPA410 Wiring Accessory	76

Chapter 4	BMX AMI 0800 Analog Input Module	79
	Presentation	80
	Characteristics	81
	Functional Description	83
	Wiring Precautions	91
	Wiring Diagram	94
	Use of the TELEFAST ABE-7CPA02/03/31E Wiring Accessory	96
Chapter 5	BMX AMI 0810 Analog Input Module	103
	Presentation	104
	Characteristics	105
	Functional Description	107
	Wiring Precautions	114
	Wiring Diagram	117
	Use of the TELEFAST ABE-7CPA02/31/31E Wiring Accessory	119
Chapter 6	BMX ART 0414/0814 Analog Input Modules	125
	Presentation	126
	Characteristics	127
	Analog Input Values	131
	Functional Description	134
	Wiring Precautions	139
	Wiring Diagram	143
	Use of the TELEFAST ABE-7CPA412 Accessory	146
Chapter 7	BMX AMO 0210 Analog Output Module	149
	Presentation	150
	Characteristics	151
	Functional Description	154
	Wiring Precautions	159
	Wiring Diagram	161
	Use of the TELEFAST ABE-7CPA21 Wiring Accessory	162
Chapter 8	BMX AMO 0410 Analog Output Module	165
	Presentation	166
	Characteristics	167
	Functional Description	169
	Wiring Precautions	174
	Wiring Diagram	176
	Use of the TELEFAST ABE-7CPA21 Wiring Accessory	177

Chapter 9	BMX AMO 0802 Analog Output Module	179
	Presentation	180
	Characteristics	181
	Functional Description	183
	Wiring Precautions	188
	Wiring Diagram	190
	Use of the TELEFAST ABE-7CPA02 Wiring Accessory	191
Chapter 10	BMX AMM 0600 Analog Input/Output Module	193
	Presentation	194
	Characteristics	195
	Functional Description	199
	Wiring Precautions	210
	Wiring Diagram	213
Part II	Software Implementation of Analog Modules	215
Chapter 11	General Overview of Analog Modules	217
	Introduction to the Installation Phase	217
Chapter 12	Configuring Analog Modules.	219
12.1	Configuring Analog Modules: Overview	220
	Description of the Configuration Screen of an Analog Module	220
12.2	Parameters for Analog Input/Output Channels	222
	Parameters for Analog Input Modules	223
	Parameters for Analog Output Modules	226
12.3	Entering Configuration Parameters Using Unity Pro	227
	Selecting the Range for an Analog Module's Input or Output	228
	Selecting a Task Associated to an Analog Channel	229
	Selecting the Input Channel Scan Cycle	230
	Selecting the Display Format for a Current or Voltage Input Channel.	231
	Selecting the Display Format for a Thermocouple or RTD Input Channel	233
	Selecting the Input Channels' Filter Value.	234
	Selecting Input Channel Usage.	235
	Selecting the Overflow Control Function	236
	Selecting the Cold Junction Compensation.	238
	Selecting the Fallback Mode for Analog Outputs	239
Chapter 13	IODDTs and Device DDTs for Analog Modules	241
	Detailed Description of T_ANA_IN_BMX-type IODDT Objects	242
	Detailed Description of T_ANA_IN_T_BMX-type IODDT Objects	245
	Detailed Description of T_ANA_OUT_BMX-type IODDT Objects	248

	Detailed Description of T_ANA_IN_GEN-type IODDT Objects	251
	Detailed Description of T_ANA_OUT_GEN-type IODDT Objects	252
	Details of the Language Objects of the IODDT of Type T_GEN_MOD	253
	Analog Device DDT	254
	MOD_FLT Byte Description	261
	Analog Device Ethernet Remote I/O Forcing Mode	262
Chapter 14	Analog Module Debugging	265
	Introducing the Debug Function of an Analog Module	266
	Description of the Analog Module Debug Screen	267
	Selecting the Adjustment Values for the Input Channels and Measurement Forcing	269
	Modification of Output Channels Adjustment Values	271
Chapter 15	Analog Module Diagnostics	273
	Diagnostics of an Analog Module.	274
	Detailed Diagnostics by Analog Channel.	276
Chapter 16	Operating Modules from the Application	279
16.1	Access to the Measurements and Statuses.	280
	Addressing of the Analog Module Objects.	281
	Module Configuration	283
16.2	Additional Programming Features	287
	Presentation of Language Objects Associated with the Analog Modules	288
	Implicit Exchange Language Objects Associated with Analog Modules	289
	Explicit Exchange Language Objects Associated with Analog Modules	290
	Management of Exchanges and Reports with Explicit Objects	293
	Language Objects Associated with Configuration	297
Part III	Quick Start: Example of Analog I/O Module Implementation.	301
Chapter 17	Description of the Application.	303
	Overview of the Application	303
Chapter 18	Installing the Application Using Unity Pro.	305
18.1	Presentation of the Solution Used	306
	Technological Choices Used	307
	The Different Steps in the Process Using Unity Pro	308
18.2	Developing the Application.	310
	Creating the Project	311
	Selection of the Analog Module	312
	Declaration of Variables	313
	Creation and Use of the DFBs	316

	Creating the Program in SFC for Managing the Tank	321
	Creating a Program in LD for Application Execution	325
	Creating a Program in LD for Application Simulation	327
	Creating an Animation Table	330
	Creating the Operator Screen	331
Chapter 19	Starting the Application.	335
	Execution of Application in Simulation Mode.	336
	Execution of Application in Standard Mode.	337
Chapter 20	Actions and transitions	345
	Transitions	346
	Actions.	348
Appendices	351
Appendix A	Characteristics of the BMX ART 0414/0814 RTD and Thermocouple Ranges	353
	Characteristics of the RTD Ranges for the BMX ART 0414/0814 Modules	354
	Characteristics of the BMX ART 0414/814 Thermocouple Ranges in Degrees Celsius	356
	Characteristics of the BMX ART 0414/814 Thermocouple Ranges in Degrees Fahrenheit.	360
Appendix B	Topological/State RAM Addressing of the Modules	365
	Topological/State RAM Addressing of Modicon X80 Analog Modules	365
Glossary	367
Index	373

Safety Information



Important Information

NOTICE

Read these instructions carefully, and look at the equipment to become familiar with the device before trying to install, operate, service, or maintain it. The following special messages may appear throughout this documentation or on the equipment to warn of potential hazards or to call attention to information that clarifies or simplifies a procedure.



The addition of this symbol to a “Danger” or “Warning” safety label indicates that an electrical hazard exists which will result in personal injury if the instructions are not followed.



This is the safety alert symbol. It is used to alert you to potential personal injury hazards. Obey all safety messages that follow this symbol to avoid possible injury or death.

DANGER

DANGER indicates a hazardous situation which, if not avoided, **will result in** death or serious injury.

WARNING

WARNING indicates a hazardous situation which, if not avoided, **could result in** death or serious injury.

CAUTION

CAUTION indicates a hazardous situation which, if not avoided, **could result in** minor or moderate injury.

NOTICE

NOTICE is used to address practices not related to physical injury.

PLEASE NOTE

Electrical equipment should be installed, operated, serviced, and maintained only by qualified personnel. No responsibility is assumed by Schneider Electric for any consequences arising out of the use of this material.

A qualified person is one who has skills and knowledge related to the construction and operation of electrical equipment and its installation, and has received safety training to recognize and avoid the hazards involved.

BEFORE YOU BEGIN

Do not use this product on machinery lacking effective point-of-operation guarding. Lack of effective point-of-operation guarding on a machine can result in serious injury to the operator of that machine.

 WARNING
UNGUARDED EQUIPMENT
<ul style="list-style-type: none">• Do not use this software and related automation equipment on equipment which does not have point-of-operation protection.• Do not reach into machinery during operation.
Failure to follow these instructions can result in death, serious injury, or equipment damage.

This automation equipment and related software is used to control a variety of industrial processes. The type or model of automation equipment suitable for each application will vary depending on factors such as the control function required, degree of protection required, production methods, unusual conditions, government regulations, etc. In some applications, more than one processor may be required, as when backup redundancy is needed.

Only you, the user, machine builder or system integrator can be aware of all the conditions and factors present during setup, operation, and maintenance of the machine and, therefore, can determine the automation equipment and the related safeties and interlocks which can be properly used. When selecting automation and control equipment and related software for a particular application, you should refer to the applicable local and national standards and regulations. The National Safety Council's Accident Prevention Manual (nationally recognized in the United States of America) also provides much useful information.

In some applications, such as packaging machinery, additional operator protection such as point-of-operation guarding must be provided. This is necessary if the operator's hands and other parts of the body are free to enter the pinch points or other hazardous areas and serious injury can occur. Software products alone cannot protect an operator from injury. For this reason the software cannot be substituted for or take the place of point-of-operation protection.

Ensure that appropriate safeties and mechanical/electrical interlocks related to point-of-operation protection have been installed and are operational before placing the equipment into service. All interlocks and safeties related to point-of-operation protection must be coordinated with the related automation equipment and software programming.

NOTE: Coordination of safeties and mechanical/electrical interlocks for point-of-operation protection is outside the scope of the Function Block Library, System User Guide, or other implementation referenced in this documentation.

START-UP AND TEST

Before using electrical control and automation equipment for regular operation after installation, the system should be given a start-up test by qualified personnel to verify correct operation of the equipment. It is important that arrangements for such a check be made and that enough time is allowed to perform complete and satisfactory testing.

WARNING

EQUIPMENT OPERATION HAZARD

- Verify that all installation and set up procedures have been completed.
- Before operational tests are performed, remove all blocks or other temporary holding means used for shipment from all component devices.
- Remove tools, meters, and debris from equipment.

Failure to follow these instructions can result in death, serious injury, or equipment damage.

Follow all start-up tests recommended in the equipment documentation. Store all equipment documentation for future references.

Software testing must be done in both simulated and real environments.

Verify that the completed system is free from all short circuits and temporary grounds that are not installed according to local regulations (according to the National Electrical Code in the U.S.A, for instance). If high-potential voltage testing is necessary, follow recommendations in equipment documentation to prevent accidental equipment damage.

Before energizing equipment:

- Remove tools, meters, and debris from equipment.
- Close the equipment enclosure door.
- Remove all temporary grounds from incoming power lines.
- Perform all start-up tests recommended by the manufacturer.

OPERATION AND ADJUSTMENTS

The following precautions are from the NEMA Standards Publication ICS 7.1-1995 (English version prevails):

- Regardless of the care exercised in the design and manufacture of equipment or in the selection and ratings of components, there are hazards that can be encountered if such equipment is improperly operated.
- It is sometimes possible to misadjust the equipment and thus produce unsatisfactory or unsafe operation. Always use the manufacturer's instructions as a guide for functional adjustments. Personnel who have access to these adjustments should be familiar with the equipment manufacturer's instructions and the machinery used with the electrical equipment.
- Only those operational adjustments actually required by the operator should be accessible to the operator. Access to other controls should be restricted to prevent unauthorized changes in operating characteristics.

About the Book



At a Glance

Document Scope

This manual describes the hardware and software implementation of Modicon X80 analog modules.

Validity Note

This documentation is valid for Unity Pro 13.1 or later.

The technical characteristics of the devices described in the present document also appear online. To access the information online:

Step	Action
1	Go to the Schneider Electric home page www.schneider-electric.com .
2	In the Search box type the reference of a product or the name of a product range. <ul style="list-style-type: none">• Do not include blank spaces in the reference or product range.• To get information on grouping similar modules, use asterisks (*).
3	If you entered a reference, go to the Product Datasheets search results and click on the reference that interests you. If you entered the name of a product range, go to the Product Ranges search results and click on the product range that interests you.
4	If more than one reference appears in the Products search results, click on the reference that interests you.
5	Depending on the size of your screen, you may need to scroll down to see the data sheet.
6	To save or print a data sheet as a .pdf file, click Download XXX product datasheet .

The characteristics that are presented in the present document should be the same as those characteristics that appear online. In line with our policy of constant improvement, we may revise content over time to improve clarity and accuracy. If you see a difference between the document and online information, use the online information as your reference.

Related Documents

Title of Documentation	Reference Number
Modicon M580, M340, and X80 I/O Platforms, Standards and Certifications	EIO0000002726 (English), EIO0000002727 (French), EIO0000002728 (German), EIO0000002730 (Italian), EIO0000002729 (Spanish), EIO0000002731 (Chinese)
Unity Pro, Operating Modes	33003101 (English), 33003102 (French), 33003103 (German), 33003104 (Spanish), 33003696 (Italian), 33003697 (Chinese)
Unity Pro, Program Languages and Structure, Reference Manual	35006144 (English), 35006145 (French), 35006146 (German), 35013361 (Italian), 35006147 (Spanish), 35013362 (Chinese)
Unity Pro, Communication, Block Library	33002527 (English), 33002528 (French), 33002529 (German), 33003682 (Italian), 33002530 (Spanish), 33003683 (Chinese)
Unity Pro, I/O Management, Block Library	33002531 (English), 33002532 (French), 33002533 (German), 33003684 (Italian), 33002534 (Spanish), 33003685 (Chinese)
Unity Pro, Concept Application Converter, User Manual	33002515 (English), 33002516 (French), 33002517 (German), 33003676 (Italian), 33002518 (Spanish), 33003677 (Chinese)

You can download these technical publications and other technical information from our website at <https://www.schneider-electric.com/en/download>

Product Related Information

 **WARNING**

UNINTENDED EQUIPMENT OPERATION

The application of this product requires expertise in the design and programming of control systems. Only persons with such expertise should be allowed to program, install, alter, and apply this product.

Follow all local and national safety codes and standards.

Failure to follow these instructions can result in death, serious injury, or equipment damage.

Part I

Physical Implementation of Analog Modules

In this Part

This part is devoted to the physical implementation of the Modicon X80 analog input and output modules, as well as of dedicated TELEFAST cabling accessories.

What Is in This Part?

This part contains the following chapters:

Chapter	Chapter Name	Page
1	General Rules for the Physical Implementation of Analog Modules	19
2	Diagnostics for Analog Modules	55
3	BMX AMI 0410 Analog Input Module	59
4	BMX AMI 0800 Analog Input Module	79
5	BMX AMI 0810 Analog Input Module	103
6	BMX ART 0414/0814 Analog Input Modules	125
7	BMX AMO 0210 Analog Output Module	149
8	BMX AMO 0410 Analog Output Module	165
9	BMX AMO 0802 Analog Output Module	179
10	BMX AMM 0600 Analog Input/Output Module	193

Chapter 1

General Rules for the Physical Implementation of Analog Modules

Subject of this Chapter

This chapter presents the general rules for implementing analog input/output modules.

What Is in This Chapter?

This chapter contains the following topics:

Topic	Page
Installing Analog Input/Output Modules	20
Fitting a 20-Pin Terminal Block to an Analog Module	23
Fitting a 28-Pin Terminal Block to an Analog Module	28
20-Pin Terminal Block Modules	31
How to Connect Analog Input/Output Modules: Connecting 20-pin Terminal Block Modules	35
28-Pin Terminal Blocks	39
How to Connect Analog Input/Output Modules: Connecting 28-pin Terminal Block Modules	44
How to Connect Analog Input/Output Modules: Connecting 40-pin Connector Modules	47
Shielding Connection Kit	50
TELEFAST Wiring Accessories Dedicated to Analog Modules	53

Installing Analog Input/Output Modules

At a Glance

The analog input/output modules are powered by the rack bus. The modules may be installed and uninstalled without turning off power supply to the rack, without causing any hazards and without there being any risk of damage or disturbance to the PLC.

Fitting operations (installation, assembly and disassembly) are described below.

Installation Precautions

The Modicon X80 analog modules may be installed in any of the positions in the rack except:

- the positions reserved for the rack power supply modules (marked PS, PS1, and PS2),
- the positions reserved for extended modules (marked XBE),
- the positions reserved for the CPU in the main local rack (marked 00 or marked 00 and 01 depending on the CPU),
- the positions reserved for the (e)X80 adapter module in the main remote drop (marked 00).

Power is supplied by the bus at the bottom of the rack (3.3 V and 24 V).

Before installing a module, you must take off the protective cap from the module connector located on the rack.

DANGER

HAZARD OF ELECTRIC SHOCK, EXPLOSION, OR ARC FLASH

While mounting / removing the modules, make sure that the terminal block is still connected to the shield bar and disconnect the voltage of sensors and pre-actuators.

Failure to follow these instructions will result in death or serious injury.

NOTE: All modules are calibrated at factory before being shipped. Generally it is not necessary to calibrate the module. However, for certain applications or because of standard requirements (e.g. in pharmaceuticals) it may be advisable or even necessary to re-calibrate the module in specified time intervals.

Installation

The diagram below shows analog input/output modules mounted on the rack.

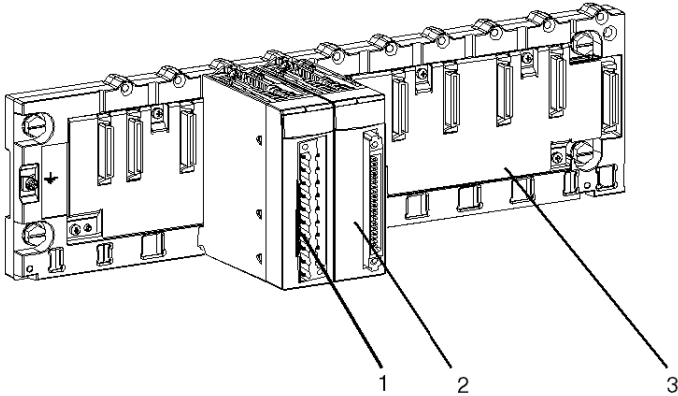

The following table describes the different elements which make up the assembly below.

Number	Description
1	20-pin terminal block module
2	40-pin connector module
3	Standard rack

Installing the Module on the Rack

The table below presents the procedure for mounting the analog input/output modules on the rack:

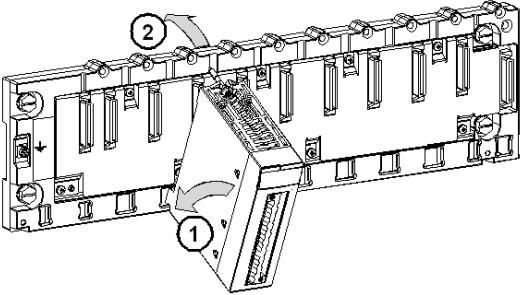
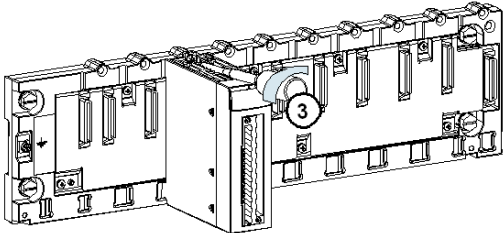
Step	Action	Illustration
1	<p>Position the locating pins situated at the rear of the module (on the bottom part) in the corresponding slots in the rack.</p> <p>Note: Before positioning the pins, make sure you have removed the protective cover.</p>	<p>Steps 1 and 2</p> 
2	<p>Swivel the module towards the top of the rack so that the module sits flush with the back of the rack. It is now set in position.</p>	
3	<p>Tighten the retaining screw to ensure that the module is held in place on the rack.</p> <p>Tightening torque: 1.5 N•m max. (1.11 lb-ft)</p>	<p>Step 3</p> 

Fitting a 20-Pin Terminal Block to an Analog Module

At a Glance

The BMX AMI 0410, BMX AMO 0210, BMX AMO 0410, BMX AMO 0802 and BMX AMM 0600 modules with 20-pin terminal block connections require the latter to be connected to the module. These fitting operations (assembly and disassembly) are described below.

⚠ CAUTION
EQUIPMENT DAMAGE Be careful not to plug an AC terminal block on a DC module. This would cause equipment damage. Failure to follow these instructions can result in injury or equipment damage.

Installing the 20-Pin Terminal Block

The following table shows the procedure for assembling the 20-pin terminal block onto BMX AMI 0410, BMX AMO 0210, BMX AMO 0410, BMX AMO 0802 and BMX AMM 0600 analog modules:

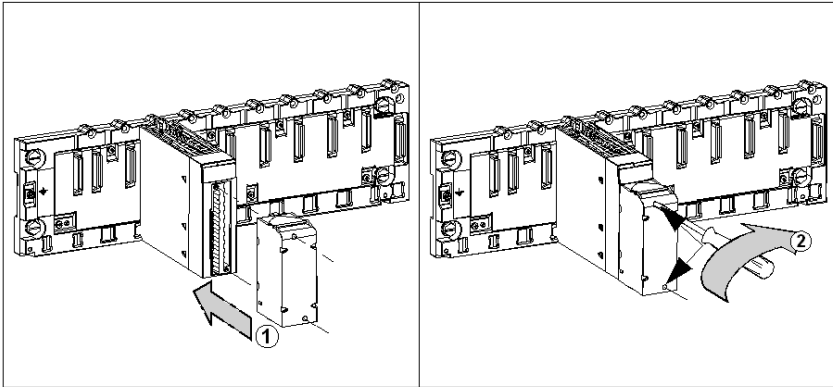

Assembly procedure:

Step	Action
1	Once the module is in place on the rack, install the terminal block by inserting the terminal block encoder (the rear lower part of the terminal) into the module's encoder (the front lower part of the module), as shown above.
2	Fix the terminal block to the module by tightening the 2 mounting screws located on the lower and upper parts of the terminal block. Tightening torque: 0.4 N•m (0.30 lb-ft).

NOTE: If the screws are not tightened, there is a risk that the terminal block will not be properly fixed to the module.

Coding the 20-Pin Terminal Block

When a 20-pin terminal block is installed on a module dedicated to this type of terminal block, you can code the terminal block and the module using studs. The purpose of the studs is to prevent the terminal block from being mounted on another module. Handling errors can then be avoided when replacing a module.

Coding is done by the user with the STB XMP 7800 guidance wheel's studs. You can only fill the 6 slots in the middle of the left side (as seen from the wiring side) of the terminal block, and can fill the module's 6 guidance slots on the left side.

To fit the terminal block to the module, a module slot with a stud must correspond to an empty slot in the terminal block, or a terminal block with a stud must correspond to an empty slot in the module. You can fill up to and including either of the 6 available slots as desired.

The diagram below shows a guidance wheel as well as the slots on the module used for coding the 20-pin terminal blocks:

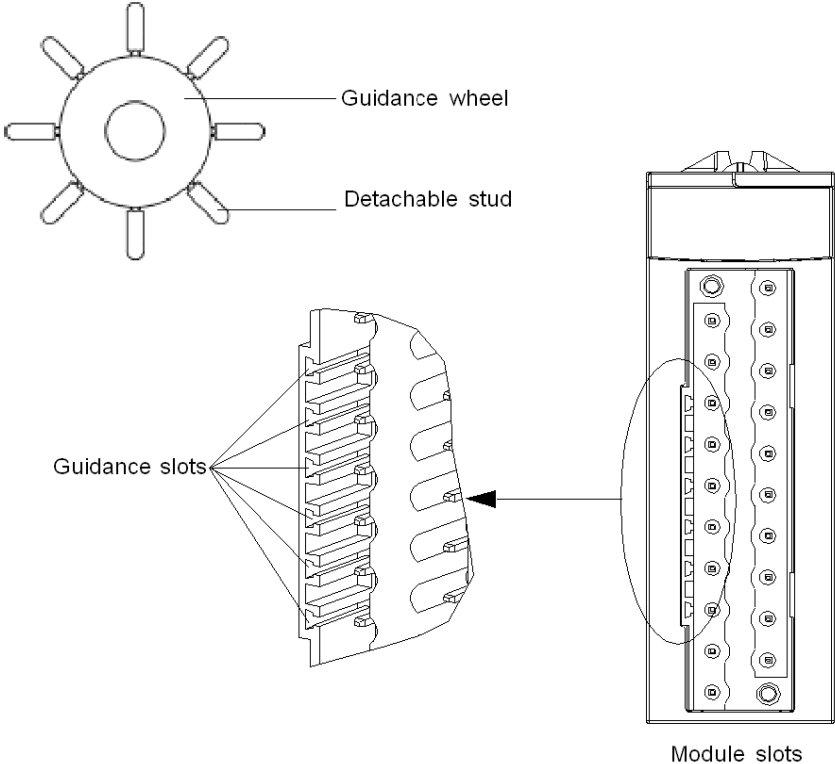

The diagram below shows an example of a coding configuration that makes it possible to fit the terminal block to the module:

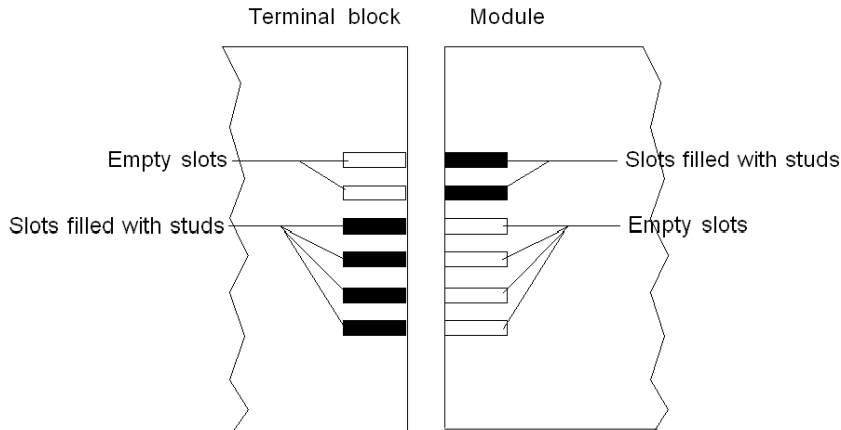

The diagram below shows an example of coding configuration with which it is not possible to fit the terminal block to the module:

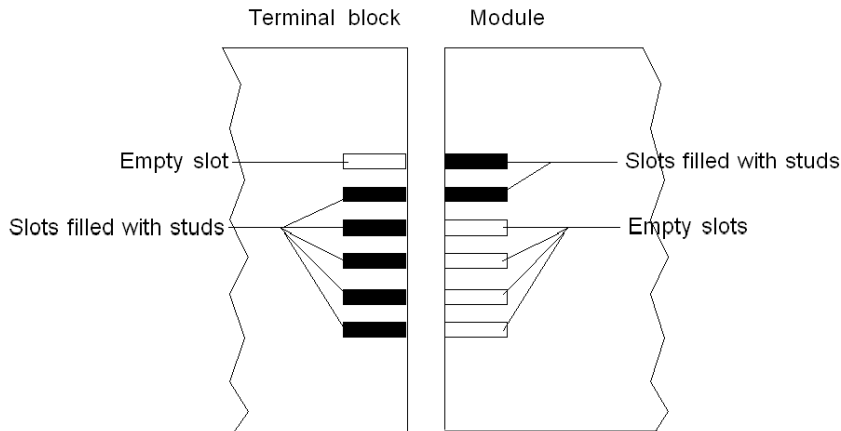

DANGER

ELECTRICAL SHOCK

Terminal block must be connected or disconnected with sensor and pre-actuator voltage switched off.

Failure to follow these instructions will result in death or serious injury.

NOTICE

POTENTIAL MODULE DAMAGE

Code the terminal block as described above to prevent the terminal block from being mounted on an incorrect module. Mounting a terminal block on an incorrect module may damage the module.

Plugging the wrong connector could cause the module to be destroyed.

Failure to follow these instructions can result in equipment damage.

CAUTION

UNEXPECTED BEHAVIOR OF APPLICATION

Code the terminal block as described above to prevent the terminal block from being mounted on another module.

Plugging the wrong connector could cause unexpected behavior of the application.

Failure to follow these instructions can result in injury or equipment damage.

NOTE: The module connector have indicators which show the proper direction to use for terminal block installation.

Fitting a 28-Pin Terminal Block to an Analog Module

At a Glance

The BMX AMI 0800 and BMX AMI 0810 modules require a 28-pin terminal block which is inserted into the front of the module. These fitting operations (assembly and disassembly) are described below.

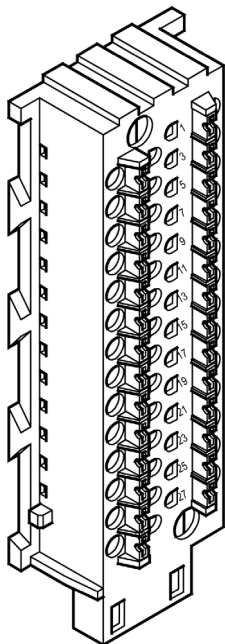

Installing the 28-Pin Terminal Block

The following table shows the procedure for assembling the 28-pin terminal block onto BMX AMI 0800 and BMX AMI 0810 analog modules:

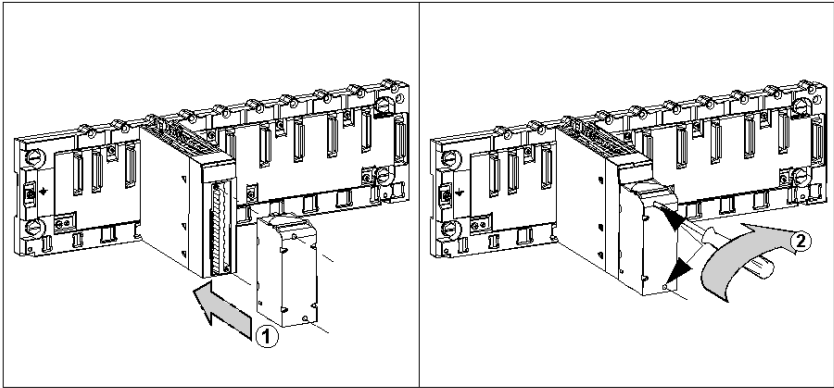

Assembly procedure:

Step	Action
1	Once the module is in place on the rack, install the terminal block by inserting the terminal block encoder (the rear lower part of the terminal) into the module's encoder (the front lower part of the module), as shown above.
2	Fix the terminal block to the module by tightening the 2 mounting screws located on the lower and upper parts of the terminal block. Tightening torque: 0.4 N.m.

NOTE: If the screws are not tightened, there is a risk that the terminal block will not be properly fixed to the module.

28-Pin Terminal Block Arrangements

The following graphic shows the 28-Pin terminal block arrangement:

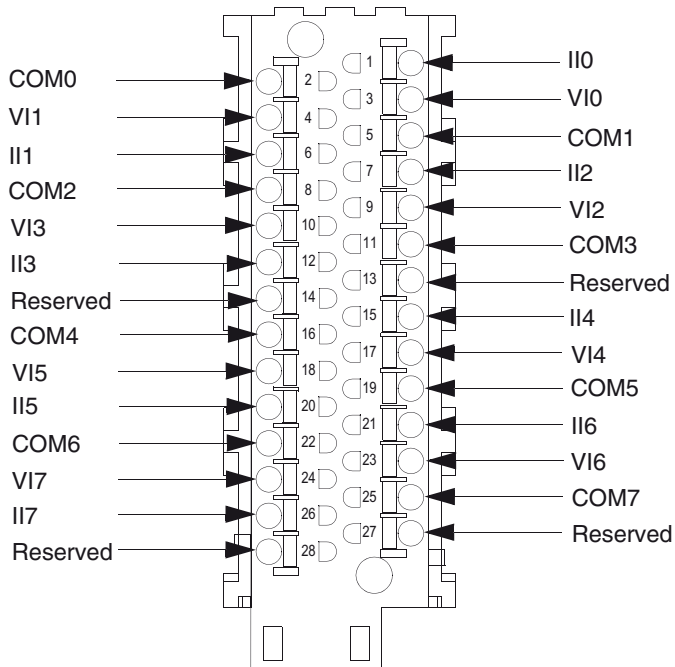

⚠ CAUTION

Electrical hazard

Follow the wiring, mounting and installation instructions.

Failure to follow these instructions can result in injury or equipment damage.

20-Pin Terminal Block Modules

At a Glance



The BMX AMI 0410, BMX AMO 0210, BMX AMO 0410, BMX AMO 0802, and BMX AMM 0600 modules are supplemented by a 20-pin terminal block.

There are three types of 20-pin terminal blocks:

- BMX FTB 2010 screw clamp terminal blocks
- BMX FTB 2000 caged terminal blocks
- BMX FTB 2020 spring terminal blocks

Cable Ends and Contacts

Each terminal block can accommodate:





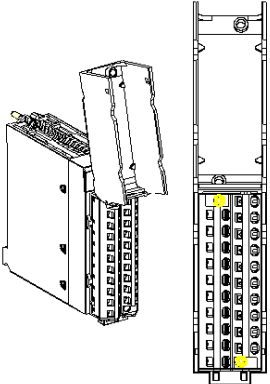
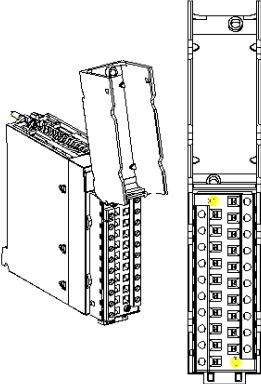
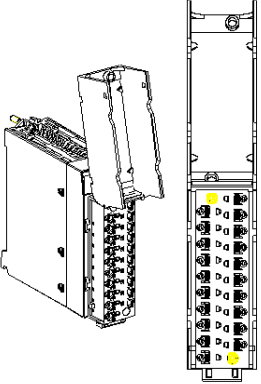

- Bare wires
- Wires with:
 - DZ5-CE (ferrule) type cable ends: 
 - AZ5-DE (twin ferrule) type cable ends: 

NOTE: When using stranded cable, Schneider Electric strongly recommends the use of wire ferrules which are fitted with an appropriate crimping tool.

Description of the 20-Pin Terminal Blocks

The following table describes the type of wires that fit each terminal block and the associated gauge range, wiring constraints, and tightening torque:

	Screw Clamp Terminal Blocks BMX FTB 2010	Caged Terminal Blocks BMX FTB 2000	Spring Terminal Blocks BMX FTB 2020
Illustration			

	Screw Clamp Terminal Blocks BMX FTB 2010	Caged Terminal Blocks BMX FTB 2000	Spring Terminal Blocks BMX FTB 2020
1 solid conductor 	<ul style="list-style-type: none"> ● AWG: 22...16 ● mm²: 0.34...1.5 	<ul style="list-style-type: none"> ● AWG: 22...18 ● mm²: 0.34...1 	<ul style="list-style-type: none"> ● AWG: 22...18 ● mm²: 0.34...1
2 solid conductors 	<p>2 conductors of the same size:</p> <ul style="list-style-type: none"> ● AWG: 2 x 22...16 ● mm²: 2 x 0.34...1.5 	<p>Only possible with twin ferrule:</p> <ul style="list-style-type: none"> ● AWG: 2 x 24...20 ● mm²: 2 x 0.24...0.75 	<p>Only possible with twin ferrule:</p> <ul style="list-style-type: none"> ● AWG: 2 x 24...20 ● mm²: 2 x 0.24...0.75
1 stranded cable 	<ul style="list-style-type: none"> ● AWG: 22...16 ● mm²: 0.34...1.5 	<ul style="list-style-type: none"> ● AWG: 22...18 ● mm²: 0.34...1 	<ul style="list-style-type: none"> ● AWG: 22...18 ● mm²: 0.34...1
2 stranded cables 	<p>2 conductors of the same size:</p> <ul style="list-style-type: none"> ● AWG: 2 x 22...16 ● mm²: 2 x 0.34...1.5 	<p>Only possible with twin ferrule:</p> <ul style="list-style-type: none"> ● AWG: 2 x 24...20 ● mm²: 2 x 0.24...0.75 	<p>Only possible with twin ferrule:</p> <ul style="list-style-type: none"> ● AWG: 2 x 24...20 ● mm²: 2 x 0.24...0.75
1 stranded cable with ferrule 	<ul style="list-style-type: none"> ● AWG: 22...16 ● mm²: 0.34...1.5 	<ul style="list-style-type: none"> ● AWG: 22...18 ● mm²: 0.34...1 	<ul style="list-style-type: none"> ● AWG: 22...18 ● mm²: 0.34...1
2 stranded cables with twin ferrule 	<ul style="list-style-type: none"> ● AWG: 2 x 24...18 ● mm²: 2 x 0.24...1 	<ul style="list-style-type: none"> ● AWG: 2 x 24...20 ● mm²: 2 x 0.24...0.75 	<ul style="list-style-type: none"> ● AWG: 2 x 24...20 ● mm²: 2 x 0.24...0.75
Minimum individual wire size in stranded cables when a ferrule is not used 	<ul style="list-style-type: none"> ● AWG: 30 ● mm²: 0.0507 	<ul style="list-style-type: none"> ● AWG: 30 ● mm²: 0.0507 	<ul style="list-style-type: none"> ● AWG: 30 ● mm²: 0.0507
Wiring constraints	<p>Screw clamps have slots that accept:</p> <ul style="list-style-type: none"> ● Flat-tipped screwdrivers with a diameter of 5 mm. ● Pozidriv PZ1 or Philips PH1 cross-tipped screwdrivers. <p>Screw clamp terminal blocks have captive screws. On the supplied blocks, these screws are not tightened.</p>	<p>Caged terminal blocks have slots that accept:</p> <ul style="list-style-type: none"> ● Flat-tipped screwdrivers with a diameter of 3 mm. <p>Caged terminal blocks have captive screws. On the supplied blocks, these screws are not tightened.</p>	<p>The wires are connected by pressing the button located next to each pin. To press the button, use a flat-tipped screwdriver with a maximum diameter of 3 mm.</p>
Screw tightening torque	0.5 N•m (0.37 lb-ft)	0.4 N•m (0.30 lb-ft)	Not applicable

⚡ ⚠ DANGER

HAZARD OF ELECTRIC SHOCK

Turn off all power to sensor and pre-actuator devices before connection or disconnection of the terminal block.

Failure to follow these instructions will result in death or serious injury.

Connection of 20-Pin Terminal Blocks

The following diagram shows the method for opening the 20-pin terminal block door so that it can be wired:

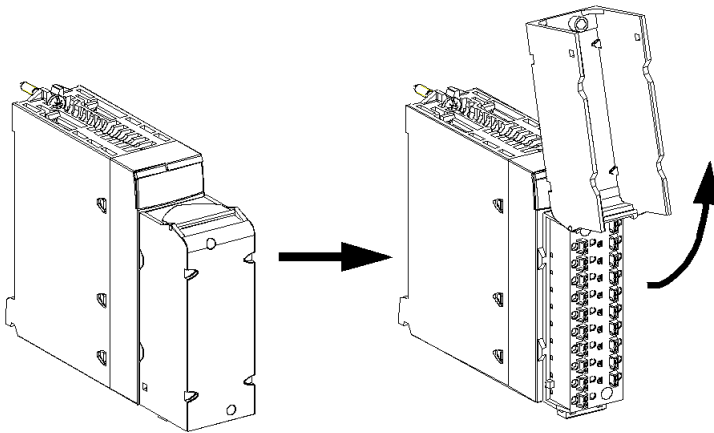

The connection cables for 20-pin terminal blocks come in 3 kinds of connections:

- Connection cables with an FTB connector, which come in 2 different lengths:
 - 3 meter: BMX FTW 301S
 - 5 meter: BMX FTW 501S
- Connection cables with an FTB and a D-Sub25 connectors for direct wiring of BMX AMI 0410 module with Telefast ABE7CPA410 or BMX AMO 0210 and BMX AMO 0410 modules with Telefast ABE7CPA21, which come in 3 different lengths:
 - 1.5 meter: BMX FCA 150
 - 3 meter: BMX FCA 300
 - 5 meter: BMX FCA 500
- Connection for BMXAMO0802 with Telefast ABE7CPA02 using 2 different lengths:
 - 1.5 meter: BMX FTA 152
 - 3 meter: BMX FTA 302

NOTE: The connection cable is installed and held in place by a cable clamp positioned below the 20-pin terminal block.

Labeling of 20-Pin Terminal Blocks

Labels for the 20-pin terminal blocks are supplied with the module. They are to be inserted in the terminal block cover by the customer.

Each label has two sides:

- One side that is visible from the outside when the cover is closed. This side features the commercial product references, an abbreviated description of the module, as well as a blank section for customer labeling.
- One side that is visible from the inside when the cover is open. This side shows the terminal block connection diagram.

How to Connect Analog Input/Output Modules: Connecting 20-pin Terminal Block Modules

Introduction

20-pin connector modules are connected to sensors, pre-actuators or terminals using a cable designed to enable direct wire to wire transition of the module's inputs/outputs.

The following diagram shows the connection of the cable to the module:

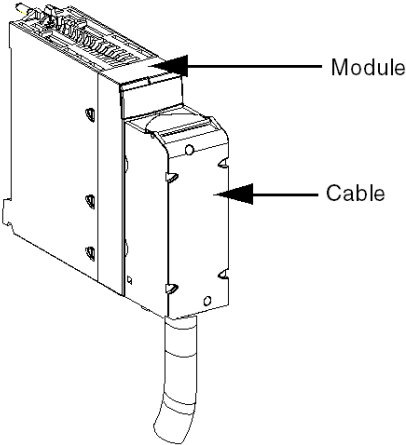

⚠ WARNING

UNEXPECTED EQUIPMENT OPERATION

Use only a connector that is designed for a specific module. Plugging the wrong connector can cause an unexpected behavior of the application.

Failure to follow these instructions can result in death, serious injury, or equipment damage.

BMX FTW ••1S Connection Cables

They are made up of:

- At one end, a compound-filled 20-pin connector from which extend 1 cable sheath, containing 20 wires with a cross-sectional area of 0.34 mm^2 (AWG 24),

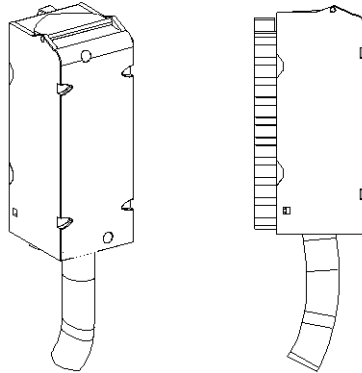

BMX FTW ••1S

- At the other end, free wire ends differentiated by color code.

The cable comes in 2 different lengths:

- 3 meters: BMX FTW 301S;
- 5 meters: BMX FTW 501S;

The figure below shows the BMX FTW ••1S cables:

Connection
on module to
20-pin
connector

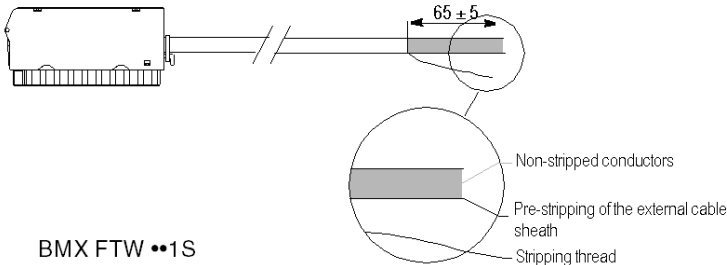

NOTE: A strand of nylon incorporated in the cable allows the cable sheath to be stripped with ease.

NOTE: Switch off sensor and pre-actuator voltage before connecting or disconnecting the 20-pin connectors.

Connection of BMX FTW ••1S Cables

The diagram below shows the connection of BMX FTW ••1S cable:

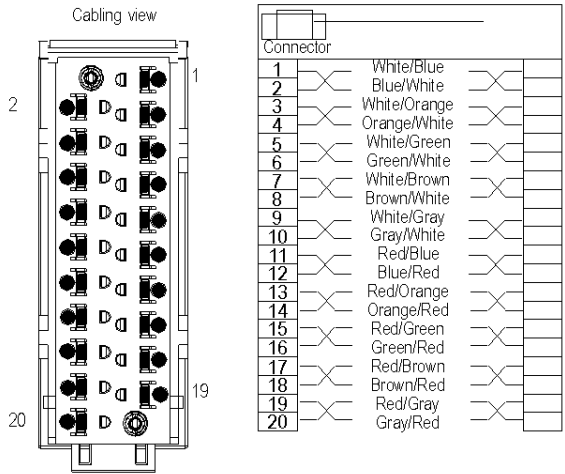

BMX FTW ••1S

28-Pin Terminal Blocks

At a Glance

There are two types of BMX AMI 0810 and BMX AMI 0800 modules are supplemented by a 28-pin terminal block.

There are two types of 28-pin terminal blocks:



- BMX FTB 2800 caged terminal blocks
- BMX FTB 2820 spring terminal blocks

There are also preassembled cordsets with BMX FTB 2820 terminal block at one end and flying leads at the other. The cordsets are available under reference BMX FTW •08S.

There are also preassembled cordsets with BMX FTB 2820 terminal block at one end and D-Sub25 connector at the other for direct wiring with Telefast. These cordsets are available under reference BMX FTA 150 and BMX FTA 300.

Cable Ends and Contacts







Each terminal block can accommodate:

- Bare wires:
 - Solid conductor
 - Stranded cable
- Wires with ferrules:
 - DZ5CE•••• single type cable ends: 
 - AZ5DE•••• twin type cable ends: 

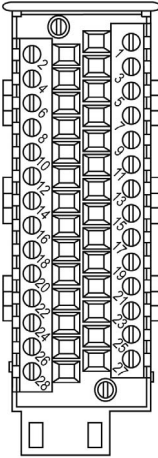
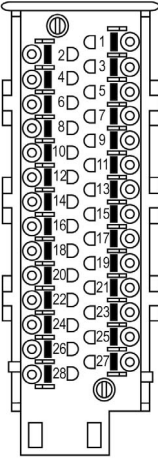
NOTE: When using stranded cable, Schneider Electric strongly recommends the use of wire ferrules which are fitted with an appropriate crimping tool.

Terminal Blocks Wiring Capacity

The following table describes the type of wires that fit each terminal block and the associated gauge range, wiring constraints, and tightening torque:

	Caged terminal blocks BMX FTB 2800	Spring terminal blocks BMX FTB 2820
Illustration		
1 solid conductor 	<ul style="list-style-type: none"> ● AWG: 22...18 ● mm²: 0.34...1 	<ul style="list-style-type: none"> ● AWG: 22...18 ● mm²: 0.34...1
2 solid conductors 	Only possible with twin ferrule: <ul style="list-style-type: none"> ● AWG: 2 x 24...20 ● mm²: 2 x 0.24...0.75 	Only possible with twin ferrule: <ul style="list-style-type: none"> ● AWG: 2 x 24...20 ● mm²: 2 x 0.24...0.75
1 stranded cable 	<ul style="list-style-type: none"> ● AWG: 22...18 ● mm²: 0.34...1 	<ul style="list-style-type: none"> ● AWG: 22...18 ● mm²: 0.34...1
2 stranded cables 	Only possible with twin ferrule: <ul style="list-style-type: none"> ● AWG: 2 x 24...20 ● mm²: 2 x 0.24...0.75 	Only possible with twin ferrule: <ul style="list-style-type: none"> ● AWG: 2 x 24...20 ● mm²: 2 x 0.24...0.75
1 stranded cable with ferrule 	<ul style="list-style-type: none"> ● AWG: 22...18 ● mm²: 0.34...1 	<ul style="list-style-type: none"> ● AWG: 22...18 ● mm²: 0.34...1
2 stranded cables with twin ferrule 	<ul style="list-style-type: none"> ● AWG: 2 x 24...20 ● mm²: 2 x 0.24...0.75 	<ul style="list-style-type: none"> ● AWG: 2 x 24...20 ● mm²: 2 x 0.24...0.75

	Caged terminal blocks BMX FTB 2800	Spring terminal blocks BMX FTB 2820
Minimum individual wire size in stranded cables when a ferrule is not used 	<ul style="list-style-type: none"> ● AWG: 30 ● mm²: 0.0507 	<ul style="list-style-type: none"> ● AWG: 30 ● mm²: 0.0507
Wiring constraints	Caged terminal blocks have slots that accept: <ul style="list-style-type: none"> ● Flat-tipped screwdrivers with a diameter of 3 mm. Caged terminal blocks have captive screws. On the supplied blocks, these screws are not tightened.	The wires are connected by pressing the button located next to each pin. To press the button, you have to use a flat-tipped screwdriver with a maximum diameter of 3 mm.
Screw tightening torque	0.4 N•m (0.30 lb-ft)	Not applicable

⚡ ⚠ DANGER

HAZARD OF ELECTRIC SHOCK

Turn off all power to sensor and pre-actuator devices before connection or disconnection of the terminal block.

Failure to follow these instructions will result in death or serious injury.

Terminal Block Cover

The following diagram shows the method for opening the terminal block cover so that it can be wired:

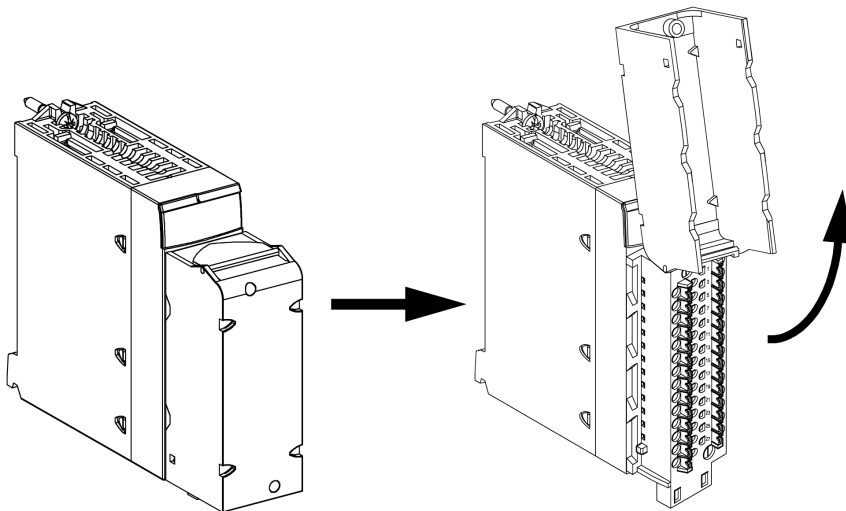

NOTE: The connection cable is installed and held in place by a cable clamp positioned below the 28-pin terminal block.

Preassembled Cordsets

The connection cables for 28-pin terminal blocks come in 2 kinds of connections:

- Connection cables with an FTB connector, which come in 2 different lengths:
 - 3 meter: BMX FTW 308S
 - 5 meter: BMX FTW 508S
- Connection cables with an FTB and a D-Sub25 connectors for direct wiring of BMX AMI 0800 module with Telefast ABE 7CPA02/03/31E or BMX AMI 0810 modules with Telefast ABE 7CPA02/31/31E, which come in 2 different lengths:
 - 1.5 meter: BMX FTA 150
 - 3 meter: BMX FTA 300

Labeling the Terminal Blocks

The labels for the terminal blocks are supplied with the module. They are to be inserted in the terminal block cover by the customer.

Each label has two sides:

- One side that is visible from the outside when the cover is closed. This side features the commercial product references, an abbreviated description of the module, as well as a blank section for customer labeling.
- One side that is visible from the inside when the cover is open. This side shows the terminal block connection diagram.

How to Connect Analog Input/Output Modules: Connecting 28-pin Terminal Block Modules

Introduction

28-pin connector modules are connected to sensors, pre-actuators or terminals using a cable designed to enable trouble-free direct wire to wire transition of the module's inputs/outputs.

The following diagram shows the connection of the cable to the module:

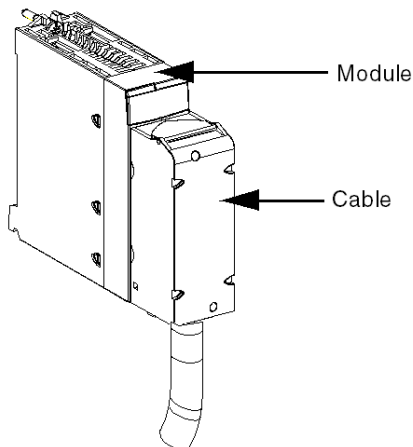

⚠ WARNING

UNEXPECTED EQUIPMENT OPERATION

Take every precaution at the installation to prevent any subsequent mistake in the connectors. Plugging the wrong connector would cause an unexpected behavior of the application.

Failure to follow these instructions can result in death, serious injury, or equipment damage.

BMX FTW ••8S Connection Cables

They are made up of:

- At one end, a compound-filled 28-pin connector from which extend 1 cable sheath, containing 24 wires with a cross-sectional area of 0.34 mm² (AWG 24),

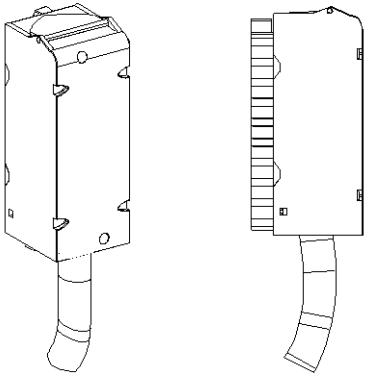

BMX FTW ••8S

- At the other end, free wire ends differentiated by color code.

The cable comes in 2 different lengths:

- 3 meters: BMX FTW 308S;
- 5 meters: BMX FTW 508S;

The figure below shows the 28-pin connector cable free wire ends :

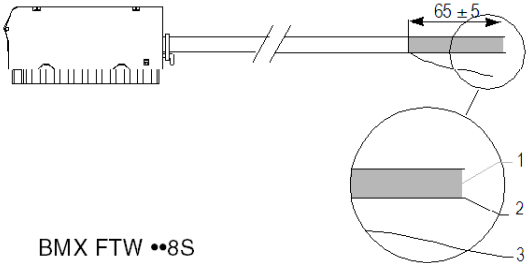

BMX FTW ••8S

- 1 Non-shipped conductors
- 2 Pre-stripping of the external cable sheath
- 3 Stripping thread

NOTE: A strand of nylon incorporated in the cable allows the cable sheath to be stripped with ease.

NOTE: The 28-pin connectors must be connected or disconnected with sensor and pre-actuator voltage switched off.

Connection of BMX FTW ••8S Cables

The diagram below shows the connection of BMX FTW ••8S cable:

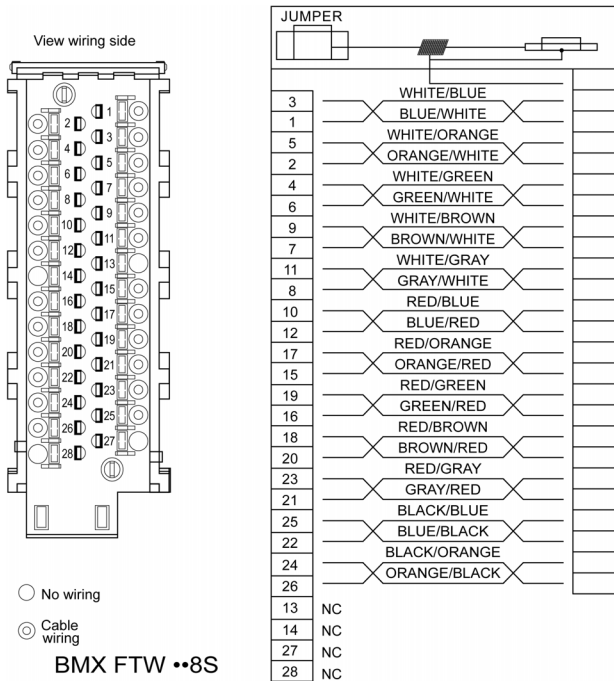

How to Connect Analog Input/Output Modules: Connecting 40-pin Connector Modules

Introduction

40-pin connector modules are connected to sensors, pre-actuators or terminals using a cable designed to enable trouble-free direct wire to wire transition of the module's inputs/outputs.

The following diagram shows the connection of the cable to the module:

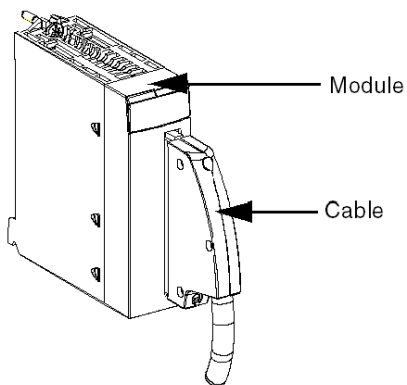

⚠ WARNING

UNEXPECTED EQUIPMENT OPERATION

Take every precaution at the installation to prevent any subsequent mistake in the connectors. Plugging the wrong connector would cause an unexpected behavior of the application.

Failure to follow these instructions can result in death, serious injury, or equipment damage.

BMX FCW ••1S Connection Cables

They are made up of:

- At one end, a compound-filled 40-pin connector from which extend 1 cable sheath, containing 20 wires with a cross-sectional area of 0.34 mm^2 (AWG 24),

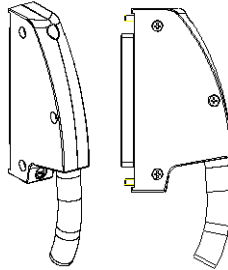

BMX FCW ••1S

- At the other end, free wire ends differentiated by color code.

The cable comes in 2 different lengths:

- 3 meters: BMX FCW 301S,
- 5 meters: BMX FCW 501S.

The figure below shows the BMX FCW ••1S cables:

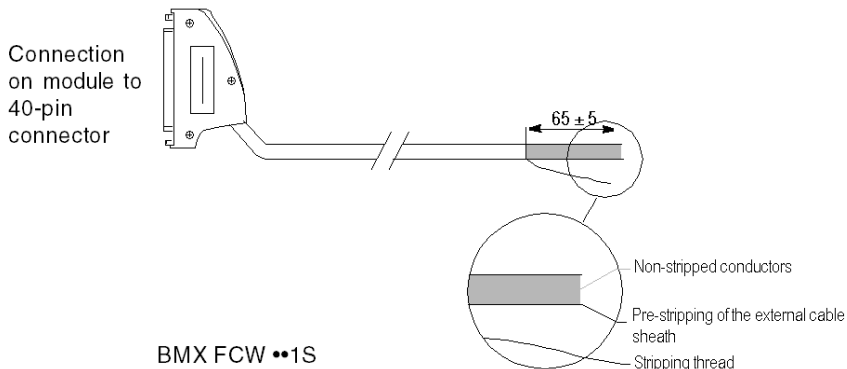

NOTE: A strand of nylon incorporated in the cable allows the cable sheath to be stripped with ease.

NOTE: The 40-pin connectors must be connected or disconnected with sensor and pre-actuator voltage switched off.

Connection of BMX FCW ••1S Cables

The diagram below shows the connection of BMX FCW ••1S cable and the signals correspondence for the BMX ART 0414/814 modules:

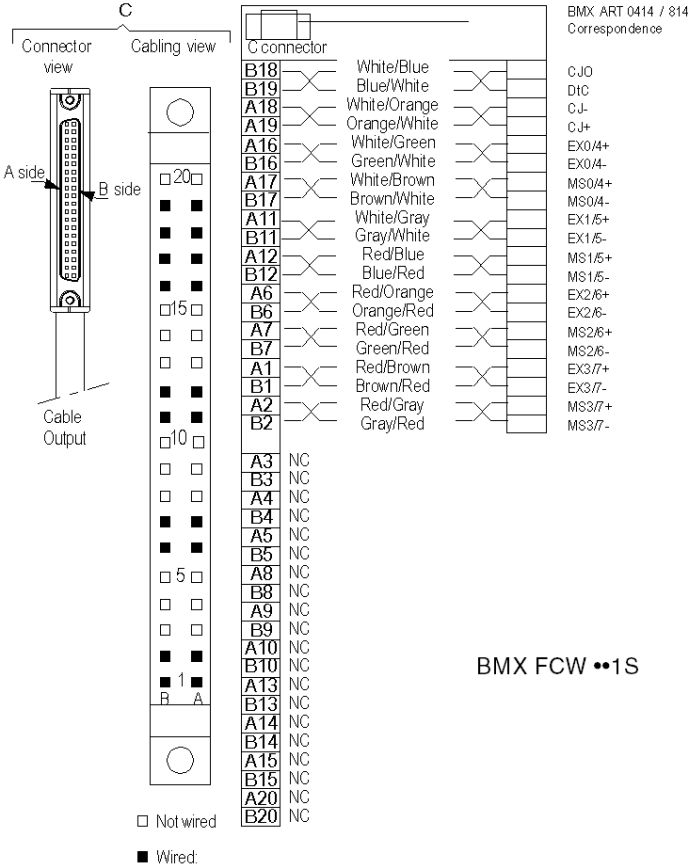

Shielding Connection Kit

Introduction

The BMXXSP.... shielding connection kit allows to connect the cable shielding directly to the ground and not to the module shielding to help protect the system from electromagnetic perturbations.

Connect the shielding on the cordsets for connecting:

- Analog module,
- Counter module,
- Encoder interface module,
- Motion control module,
- An XBT console to the processor (via shielded USB cable).

Kit References

Each shielding connection kit includes the following components:

- A metal bar
- Two sub-bases

The reference is dependent on the number of slots on the Modicon X80 rack:

Modicon X80 rack	Number of slots	Shielding Connection Kit
BMXXBP0400(H) BMEXBP0400(H)	4	BMXXSP0400
BMXXBP0600(H) BMEXBP0600(H)	6	BMXXSP0600
BMXXBP0800(H) BMEXBP0800(H) BMEXBP0602(H)	8	BMXXSP0800
BMXXBP1200(H) BMEXBP1200(H) BMEXBP1002(H)	12	BMXXSP1200

Clamping Rings

Use clamping rings to connect the shielding on cordsets to the metal bar of the kit.

NOTE: The clamping rings are not included in the shielding connection kit.

Depending on the cable diameter, the clamping rings are available under the following references:

- STBXSP3010: small rings for cables with cross-section 1.5...6 mm² (AWG16...10).
- STBXSP3020: large rings for cables with cross-section 5...11 mm² (AWG10...7).

Kit Installation

Installation of the shielding connection kit to the rack can be done with module already installed on the rack except for the BMXXBE0100 rack extender module.

Fasten the sub-bases of the kit at each end of the rack to provide a connection between the cable and the ground screw of the rack:

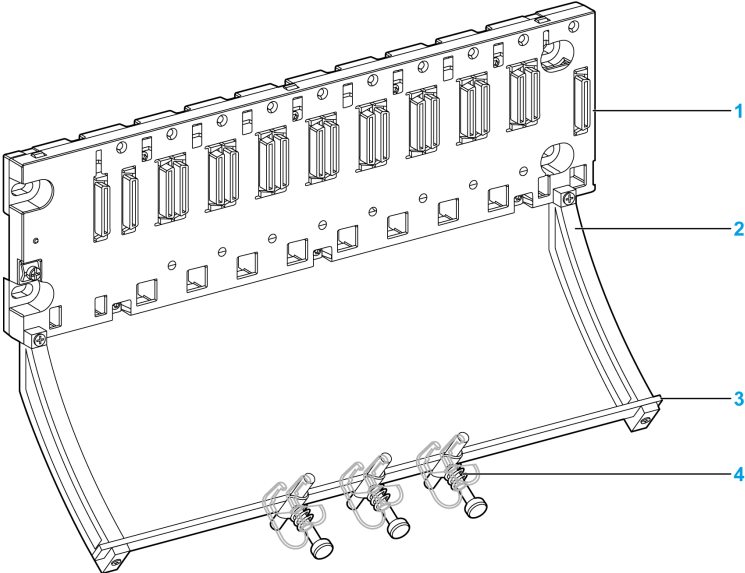

- 1 rack
- 2 sub-base
- 3 metallic bar
- 4 clamping ring

Tightening torques to install the shielding connection kit:

- For the screws fixing the sub-base to the Modicon X80 rack: Max. 0.5 N•m (0.37 lb-ft)
- For the screws fixing the metallic bar to the sub-bases: Max. 0.75 N•m (0.55 lb-ft)

NOTE: A shielding connection kit does not modify the volume required when installing and uninstalling modules.

Kit Dimensions

The following figure gives the dimensions (height and depth) of a Modicon X80 rack with its shielding connection kit:

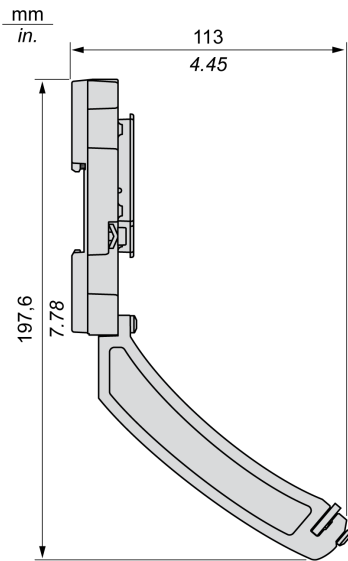

NOTE: The overall width equals to the width of the Modicon X80 rack.

TELEFAST Wiring Accessories Dedicated to Analog Modules

At a Glance

Two TELEFAST wiring accessories are available:

- **ABE-7CPA410**: specifically designed for the **BMX AMI 0410** module. In addition to distributing 4 channels to the screw terminal blocks.

It is also used to:

- Supply, channel by channel, sensors with a protected 24 V, current limited to 25 mA/channel, while maintaining isolation between the module channels.
 - Protect current shunts contained in the modules against over voltage.
- **ABE-7CPA412**: specifically designed for the **BMX ART 0414/0814** module. It distributes 4 or 8 channels from one to two 40-pin FCN connectors for connecting thermocouples. It includes a cold junction compensation circuit at 1.5°C (2.7°F). All four or eight channels may be used. When extending to an intermediary isothermal terminal block, it is possible to carry out a cold junction compensation by connecting to channel 0, by either:
 - dedicating channel 0 to 2 -3 wire Pt100 for CJC.
 - using the CJC values of channels 4/7 for channels 0/3.I.

Illustration

The analog module may be connected to the TELEFAST accessories using a 5-, 3- or 1.5-meter shielded cable.

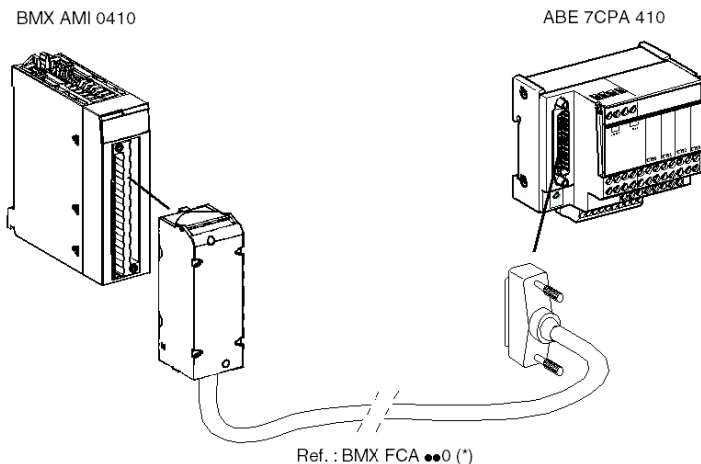

- (*) BMX FCA 150 : 1.5 m
- BMX FCA 300 : 3.0 m
- BMX FCA 500 : 5.0 m

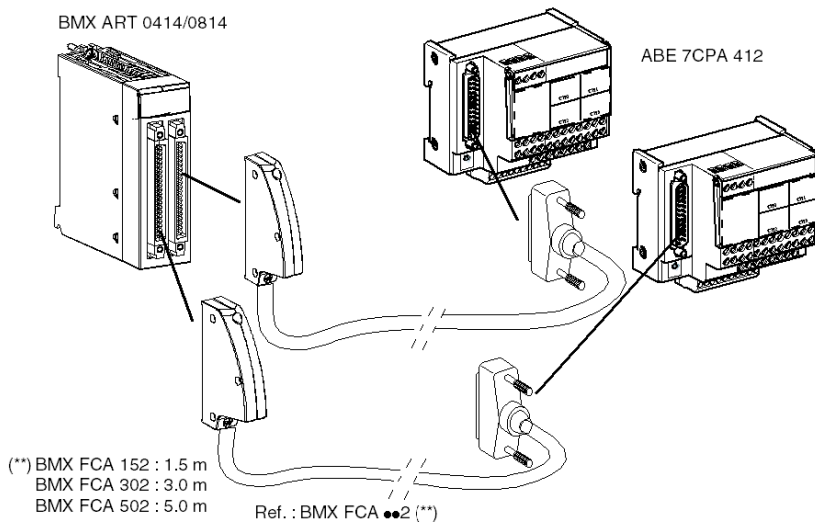

- (**) BMX FCA 152 : 1.5 m
- BMX FCA 302 : 3.0 m
- BMX FCA 502 : 5.0 m

Chapter 2

Diagnostics for Analog Modules

Subject of this Section

This section explains the processing of hardware detected faults related to analog input and output modules.

What Is in This Chapter?

This chapter contains the following topics:

Topic	Page
Display of Analog Module States	56
Analog Module Diagnostics	57

Display of Analog Module States

At a Glance

Analog modules have LEDs which show the module's status and the status of the channels. These are:

- Module status LEDs: RUN, ERR and I/O.
- Channels status LEDs: IN • (for input modules), OUT • (for output modules).

Description

The modules have several LEDs that indicate their status:

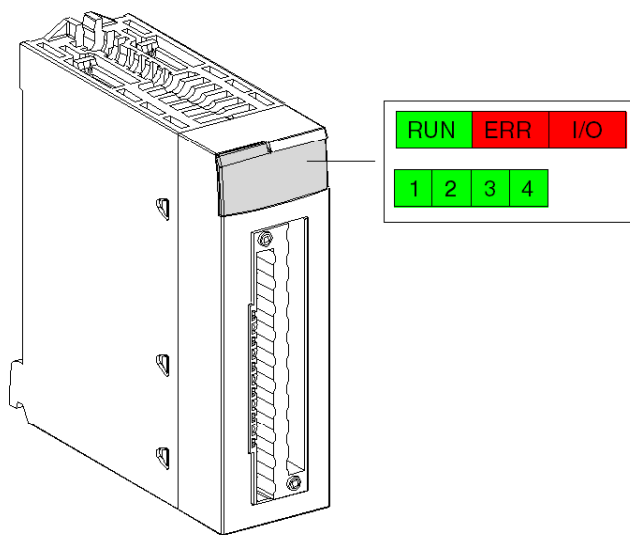

Description of the LEDs:

LED	Meaning
RUN (green)	Module operating status
ERR (red)	Internal detected error in the module or a conflict between the module and the remainder of the configuration.
I/O (red)	External error

Analog Module Diagnostics

At a Glance

The status of the analog module is indicated by the lighting up or flashing of the RUN, ERR, I/O and channel LEDs.

Description

The following table allows you to perform diagnostics of the module status according to the LEDs: RUN, ERR, I/O and channels:

Module status	Status LEDs			
	RUN	ERR	I/O	IN • or OUT •
Operating normally	●	○	○	●
Module is running with channels in stopped state	●	○	○	○
Module is inoperative or switched off	○	○	○	○
Module not configured or channel configuration in progress	⊗	○	○	○
Internal error in module	○	●	○	○
Module not calibrated to factory settings (1)	●	○	●	○
Module is experiencing difficulties communicating with the CPU (1)	●	⊗	○	●
Module not configured	○	⊗	○	○
External error:				
● Range under/overflow error.	●	○	●	⊗ (2)
● Sensor or actuator link error.	●	○	●	⊗ (2)
Legend:				
○	LED off			
⊗	LED flashing			
⊗	LED flashing rapidly			
●	LED on			
(1) only on the BMX AMO 0210 module				
(2) one or more LEDs				

Chapter 3

BMX AMI 0410 Analog Input Module

Subject of this Chapter

This chapter presents the BMX AMI 0410 module, its characteristics, and explains how it is connected to the various sensors.

What Is in This Chapter?

This chapter contains the following topics:

Topic	Page
Presentation	60
Standards and Certifications	61
Characteristics	62
Functional Description	64
Wiring Precautions	71
Wiring Diagram	75
Use of the TELEFAST ABE-7CPA410 Wiring Accessory	76

Presentation

Function

The BMX AMI 0410 module is a high-level, 4-input industrial measurement device.

Used in conjunction with sensors or transmitters, it performs monitoring, measurement, and continuous process control functions.

The BMX AMI 0410 module offers the following range for each input, according to the selection made during configuration:

- Voltage +/-10 V/0..5 V/0..10 V/1..5 V/+/- 5 V
- Current 0..20 mA/4..20 mA/+/- 20 mA

The module operates with voltage inputs. It includes four read resistors connected to the terminal block to perform current inputs.

Illustration

BMX AMI 0410 analog input module looks like this.

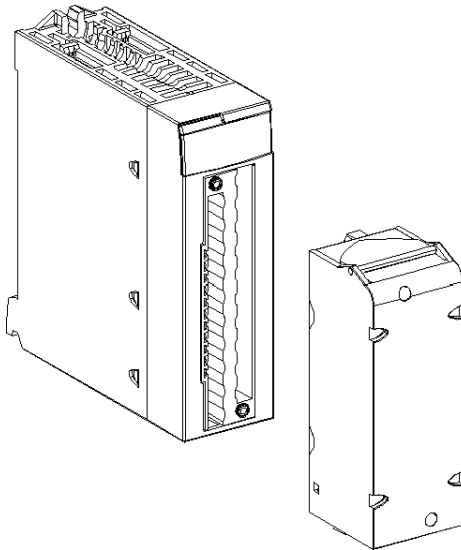

NOTE: The terminal block is supplied separately.

Standards and Certifications

Online Help

From the Unity Pro online help, you can access the standards and certifications that apply to the modules in this product line by referring to the *Modicon M580, M340, and X80 I/O Platforms, Standards and Certifications* guide.

Download

Click the link that corresponds to your preferred language to download the standards and certifications (PDF format) that apply to the modules in this product line:

Language	
English	<i>Modicon M580, M340, and X80 I/O Platforms, Standards and Certifications</i>
French	<i>Modicon M580, M340, and X80 I/O Platforms, Standards and Certifications</i>
German	<i>Modicon M580, M340, and X80 I/O Platforms, Standards and Certifications</i>
Italian	<i>Modicon M580, M340, and X80 I/O Platforms, Standards and Certifications</i>
Spanish	<i>Modicon M580, M340, and X80 I/O Platforms, Standards and Certifications</i>
Chinese	<i>Modicon M580, M340, and X80 I/O Platforms, Standards and Certifications</i>

Characteristics

General Characteristics

The general characteristics for the BMX AMI 0410 and BMX AMI 0410H modules are as follows.

Type of inputs		Isolated high level inputs
Nature of inputs		Voltage / Current
Number of channels		4
Acquisition cycle time:		
<ul style="list-style-type: none"> Fast (periodic acquisition for the declared channels used) 		1 ms + 1 ms x number of channels used
<ul style="list-style-type: none"> Default (periodic acquisition for all channels) 		5 ms
Display resolution		16-bit
Digital filtering		First order
Isolation:		
<ul style="list-style-type: none"> Between channels 		+/-300 VDC
<ul style="list-style-type: none"> Between channels and bus 		1400 VDC
<ul style="list-style-type: none"> Between channels and ground 		1400 VDC
Maximum overload authorized for inputs:		Voltage inputs: +/- 30 VDC Current inputs: +/- 90 mA Protected for accidental: -19.2 - 30 VDC wiring
Power consumption (3.3 V)	Typical	0.32 W
	Maximum	0.48 W
Power consumption (24 V)	Typical	0.82 W
	Maximum	1.30 W

Measurement Range

The BMX AMI 0410 and BMX AMI 0410H analog inputs have the following measurement range characteristics:

Measurement range	+/-10 V; +/-5 V; 0..10 V; 0.5 V; 1..5 V	0..20 mA; 4..20 mA; +/- 20 mA
Maximum conversion value	+/-11.4 V	+/-30 mA
Conversion resolution	0.35 mV	0.92 μ A
Input impedance	10 M Ω	Internal conversion resistor (250 Ω) + Internal protection resistor (see note)
Precision of the internal conversion resistor	-	0.1% - 15 ppm/ $^{\circ}$ C
Measurement errors for standard module:		
<ul style="list-style-type: none"> At 25$^{\circ}$C Maximum in the temperature range 0...60$^{\circ}$C (32...140$^{\circ}$F) 	0.075% of FS (1) 0.1% of FS (1)	0.15% of FS (1)(2) 0.3% of FS (1)(2)
Measurement errors for Hardened module:		
<ul style="list-style-type: none"> At 25$^{\circ}$C Maximum in the temperature range - 25...70$^{\circ}$C (-13...158$^{\circ}$F) 	0.075% of FS (1) 0.2% of FS (1)	0.15% of FS (1)(2) 0.55% of FS (1)(2)
Temperature drift	15 ppm/ $^{\circ}$ C	30 ppm/ $^{\circ}$ C
Monotonicity	Yes	Yes
Crosstalk between channels DC and AC 50/60Hz	> 80dB	> 80dB
Non-linearity	0.001% of FS	0.001% of FS
Repeatability @25 $^{\circ}$ C of 10 min. stabilization time	0.005% of FS	0.007% of FS
Long term stability after 1000 hours	< 0.004% of FS	< 0.004% of FS
Legend:		
(1) FS: Full Scale		
(2) With conversion resistor error		

NOTE: The internal protection resistor has a typical impedance of 25 Ω (min 3.6 Ω and max 50 Ω), The precision of the protection resistor does not impact the measured value.

NOTE: If nothing is connected on a BMX AMI 0410 analog module and if channels are configured (range 4-20 mA or 1-5 V), a broken wire causes a detected I/O error.

Functional Description

Function

The BMX AMI 0410 module is a high-level, 4-input industrial measurement device.

Used in conjunction with sensors or transmitters, it performs monitoring, measurement, and continuous process control functions.

The BMX AMI 0410 module offers the following range for each input, according to the selection made during configuration:

- +/-10 V
- 0..10 V
- 0..5 V / 0..20 mA
- 1..5 V / 4..20 mA
- +/- 5 V +/- 20 mA

The module operates with voltage inputs. It includes four read resistors connected to the terminal block to perform current inputs.

Illustration

The BMX AMI 0410 module's illustration is as follows.

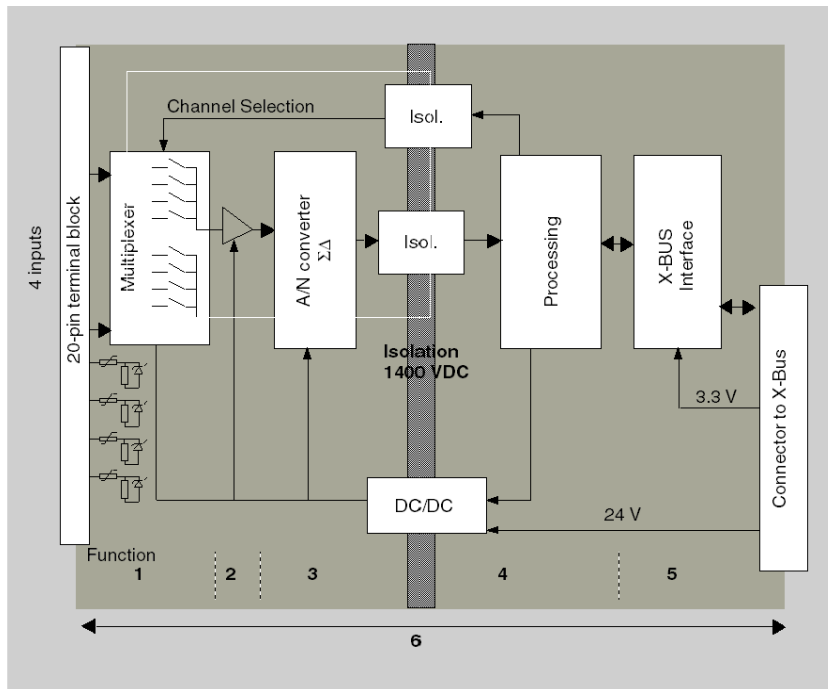

Description.

No.	Process	Function
1	Adapting the Inputs and Multiplexing	<ul style="list-style-type: none"> ● Physical connection to the process through a 20-pin screw terminal block. ● Protection of the module against overvoltages. ● Protection of the current reading resistors using limiters and resettable fuses. ● Input signal analog filtering. ● Scan input channels using static multiplexing through opto-switches, in order to provide the possibility of common mode voltage of +/- 300 VDC.
2	Amplifying Input Signals	<ul style="list-style-type: none"> ● Gain selecting, based on characteristics of input signals, as defined during configuration (unipolar or bipolar range, in voltage or current). ● Compensation of drift in amplifier device.
3	Converting	<ul style="list-style-type: none"> ● Conversion of analog Input signal into digital 24-bit signal using a $\Sigma\Delta$ converter.
4	Transforming incoming values into workable measurements for the user.	<ul style="list-style-type: none"> ● Takes into account recalibration and alignment coefficients to be applied to measurements, as well as the module's self-calibration coefficients. ● (Numeric) filtering of measurements, based on configuration parameters. ● Scaling of measurements, based on configuration parameters.
5	Communicating with the Application	<ul style="list-style-type: none"> ● Manages exchanges with CPU. ● topological addressing. ● Receives configuration parameters from module and channels. ● Sends measured values, as well as module status, to application.
6	Module monitoring and sending error notification back to application.	<p>Conversion string test. Testing for range overflow on channels. Watchdog test.</p>

Measurement Timing

The timing of measurements is determined by the cycle selected during configuration: Normal or Fast Cycle.

- Normal Cycle means that the scan cycle duration is fixed.
- With the Fast Cycle, however, the system only scans the channels designated as being In Use. The scan cycle duration is therefore proportional to the number of channels In Use.

The cycle time values are based on the cycle selected.

Module	Normal Cycle	Fast Cycle
BMX AMI 0410	5 ms	1 ms + (1 ms x N) where N: number of channels in use.

NOTE: Module cycle is not synchronized with the PLC cycle. At the beginning of each PLC cycle, each channel value is taken into account. If the MAST/FAST task cycle time is less than the module's cycle time, some values will not have changed.

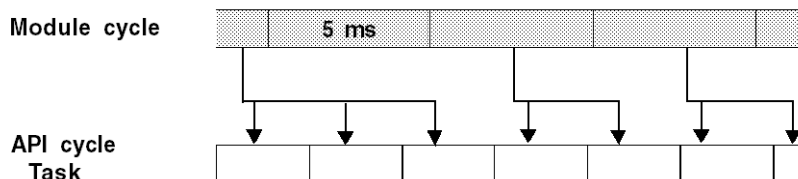

Overflow/Underflow Control

Module BMX AMI 0410 allows the user to select between 6 voltage or current ranges for each input.

This option for each channel have to be configured in configuration windows. Upper and lower tolerance detection are always active regardless of overflow/underflow control.

Depending on the range selected, the module checks for overflow: it verifies that the measurement falls between a lower and an upper threshold.

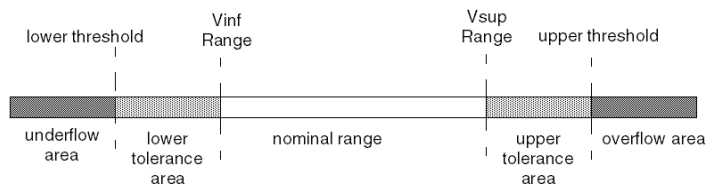

Description:

Designation	Description
Nominal range	measurement range corresponding to the chosen range
Upper Tolerance Area	varies between the values included between the maximum value for the range (for instance: +10 V for the +/-10 V range) and the upper threshold
Lower Tolerance Area	varies between the values included between the minimum value for the range (for instance: -10 V for the +/-10 V range) and the lower threshold
Overflow Area	area located beyond the upper threshold
Underflow Area	area located below the lower threshold

The values of the thresholds are configurable independently from one another. They may assume integer values between the following limits.

Range	BMX AMI 0410 Range									
	Underflow Area		Lower Tolerance Area		Nominal Range		Upper Tolerance Area		Overflow Area	
Unipolar										
0...10 V	-1,400	-1,001	-1,000	-1	0	10,000	10,001	11,000	11,001	11,400
0...5 V / 0...20 mA	-5,000	-1,001	-1,000	-1	0	10,000	10,001	11,000	11,001	15,000
1...5 V / 4...20 mA	-4,000	-801	-800	-1	0	10,000	10,001	10,800	10,801	14,000
Bipolar										
+/- 10 V	-11,400	-11,001	-11,000	-10,001	-10,000	10,000	10,001	11,000	11,001	11,400
+/- 5 V, +/- 20 mA	-15,000	-11,001	-11,000	-10,001	-10,000	10,000	10,001	11,000	11,001	15,000
User										
+/- 10 V	-32,768				User-defined	User-defined				32,767
0...10 V	-32,768				User-defined	User-defined				32,767

Measurement Display

Measurements may be displayed using standardized display (in %, to two decimal places).

Type of Range	Display
Unipolar range 0...10 V, 0...5 V, 1...5 V, 0...20mA, 4...20mA	from 0 to 10,000 (0 % at +100.00 %)
Bipolar range +/- 10 V, +/- 5 mV +/- 20 mA	from -10,000 to 10,000 (-100.00 % at +100.00 %)

It is also possible to define the range of values within which measurements are expressed, by selecting:

- the lower threshold corresponding to the minimum value for the range: 0 % (or -100.00 %).
- the upper threshold corresponding to the maximum value for the range (+100.00 %).

The lower and upper thresholds must be integers between -32,768 and +32,767.

For example, imagine a conditioner providing pressure data on a 4-20 mA loop, with 4 mA corresponding to 3,200 millibar and 20 mA corresponding to 9,600 millibar. You have the option of choosing the User format, by setting the following lower and upper thresholds:

3,200 for 3,200 millibar as the lower threshold

9,600 for 9,600 millibar as the upper threshold

Values transmitted to the program vary between 3,200 (= 4 mA) and 9,600 (= 20 mA).

Measurement Filtering

The type of filtering performed by the system is called "first order filtering". The filtering coefficient can be modified from a programming console or via the program.

The mathematical formula used is as follows:

$$Meas_{f(n)} = \alpha \times Meas_{f(n-1)} + (1 - \alpha) \times Val_{b(n)}$$

where:

α = efficiency of the filter

$Meas_{f(n)}$ = measurement filtered at moment n

$Meas_{f(n-1)}$ = measurement filtered at moment n-1

$Val_{b(n)}$ = gross value at moment n

You may configure the filtering value from 7 possibilities (from 0 to 6). This value may be changed even when the application is in RUN mode.

NOTE: Filtering may be accessed in Normal or Fast Cycle.

The filtering values depend on the T configuration cycle (where T = cycle time of 5 ms in standard mode):

Desired Efficiency	Required Value	Corresponding α	Filter Response Time at 63%	Cut-off Frequency (in Hz)
No filtering	0	0	0	0
Low filtering	1	0.750	4 x T	0.040 / T
	2	0.875	8 x T	0.020 / T
Medium filtering	3	0.937	16 x T	0.010 / T
	4	0.969	32 x T	0.005 / T
High filtering	5	0.984	64 x T	0.0025 / T
	6	0.992	128 x T	0.0012 / T

Sensor Alignment

The process of "alignment" consists in eliminating a systematic offset observed with a given sensor, around a specific operating point. This operation compensates for an error linked to the process. Replacing a module does not therefore require a new alignment. However, replacing the sensor or changing the sensor's operating point does require a new alignment.

Conversion lines are as follows:

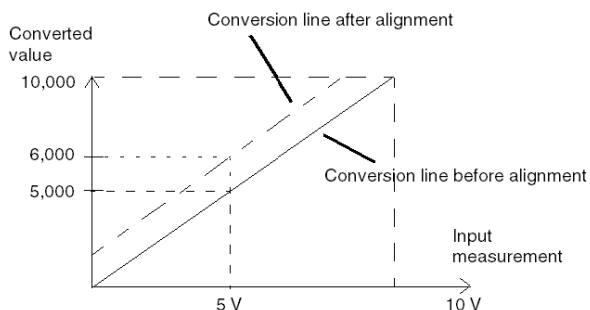

The alignment value is editable from a programming console, even if the program is in RUN Mode. For each input channel, you can:

- view and modify the desired measurement value
- save the alignment value
- determine whether the channel already has an alignment

The alignment offset may also be modified through programming.

Channel alignment is performed on the channel in standard operating mode, without any effect on the channel's operating modes.

The maximum offset between measured value and desired (aligned) value may not exceed +/- 1,500.

NOTE: To align several analog channels on the BMX ART/AMO/AMI/AMM modules, we recommend proceeding channel by channel. Test each channel after alignment before moving to the next channel in order to apply the parameters correctly.

Wiring Precautions

Introduction

In order to protect the signal from outside interference induced in series mode and interference in common mode, we recommend that you take the following precautions.

Cable Shielding

Connect the cable shielding to the grounding bar. Clamp the shielding to the grounding bar on the module side. Use the shielding connection kit BMXXSP•••• (see page 50) to connect the shielding.

⚠ DANGER

HAZARD OF ELECTRIC SHOCK, EXPLOSION, OR ARC FLASH

While mounting / removing the modules:

- make sure that each terminal block is still connected to the shield bar and
- disconnect voltage supplying sensors and pre-actuators.

Failure to follow these instructions will result in death or serious injury.

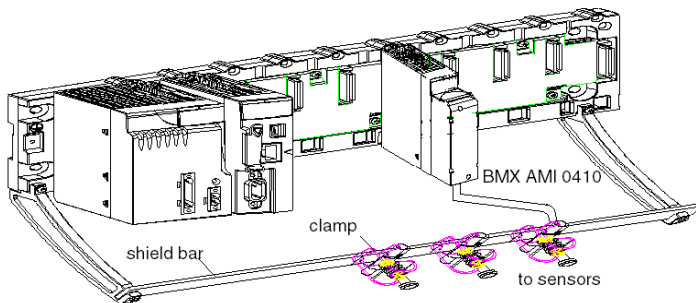

- TELEFAST connection:
Connect the sensor cable shielding to the terminals provided and the whole assembly to the cabinet ground.

Telefast ABE-7CPA410

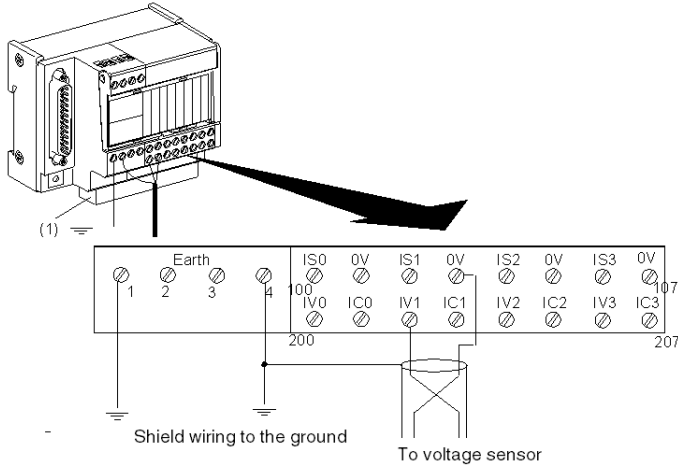

(1) The grounding of cables is facilitated using the ABE-7BV10 accessory.

Reference of Sensors in Relation to the Ground

In order for the acquisition system to operate correctly, we recommend you take the following precautions:

- sensors must be close together (a few meters)
- all sensors must be referenced to a single point, which is connected to the PLC's ground

Using the Sensors Referenced in Relation to the Ground

The sensors are connected as indicated in the following diagram:

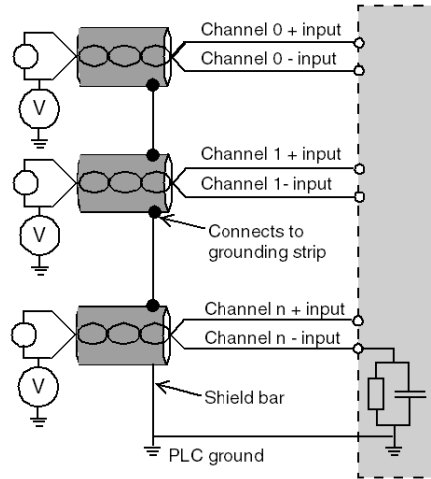

If the sensors are referenced in relation to the ground, this may in some cases return a remote ground potential to the terminal block. It is therefore **essential** to follow the following rules:

- The potential must be less than the permitted low voltage: for example, 30 Vrms or 42.4 VDC.
- Setting a sensor point to a reference potential generates a leakage current. You must therefore check that all leakage currents generated do not disturb the system.

⚠ DANGER

HAZARD OF ELECTRIC SHOCK

Sensors and other peripherals may be connected to a grounding point some distance from the module. Such remote ground references may carry considerable potential differences with respect to local ground.

Ensure that:

- potentials greater than permitted low limits cannot exist,
- induced currents do not affect the measurement or integrity of the system.

Failure to follow these instructions will result in death or serious injury.

Electromagnetic Hazard Instructions

CAUTION

UNEXPECTED BEHAVIOR OF APPLICATION

Follow those instructions to reduce electromagnetic perturbations:

- use the shielding connection kit BMXXSP•••• (see page 50) to connect the shielding.

Electromagnetic perturbations may lead to an unexpected behavior of the application.

Failure to follow these instructions can result in injury or equipment damage.

Wiring Diagram

Introduction

Module BMX AMI 0410 is connected using the 20-point terminal block.

Illustration

The terminal block connection and the sensor wiring are as follows.

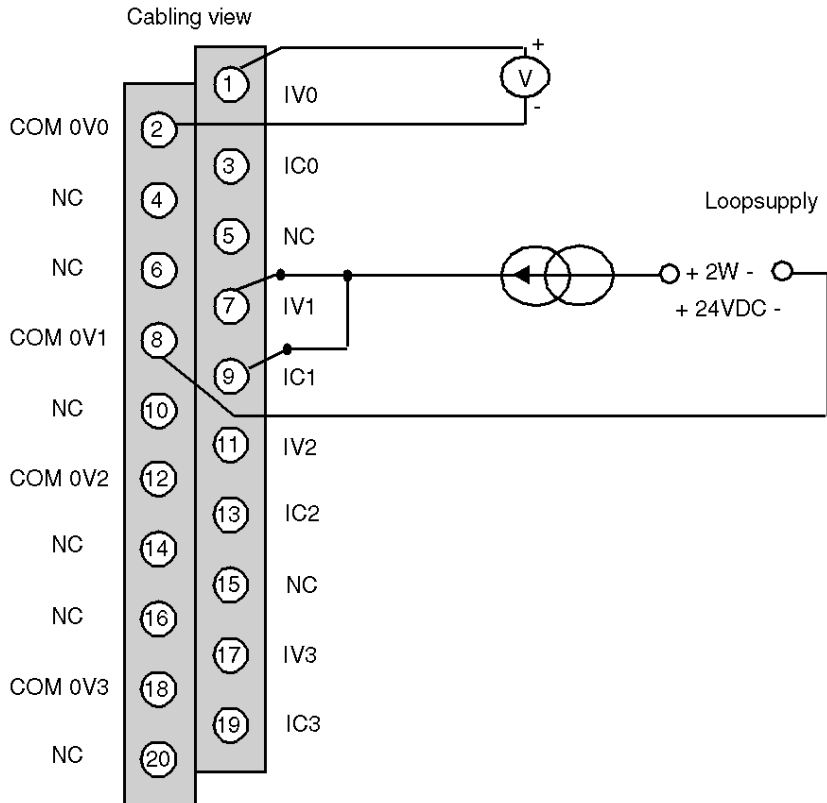

IVx + pole input for channel x
COM 0Vx - pole input for channel x
ICx current reading resistor + input
Channel 0 voltage sensor
Channel 1 2-wire current sensor

Use of the TELEFAST ABE-7CPA410 Wiring Accessory

At a Glance

The TELEFAST ABE-7CPA410 accessory is a base unit used for the connection of sensors. It has the following functions:

- Extend the input terminals in voltage mode.
- Supply, channel by channel, the 0-20 mA or 4-20 mA sensors with a protected 24 V voltage, limited in current to 25 mA, while maintaining isolation between the channels.
- Protect current reading resistors that are integrated in TELEFAST against overvoltage.

Channels to channels isolation	750 Vdc
Channels to 24Vdc supply isolation	750Vdc
Overvoltage protection on current inputs	By Zener diodes 8,2V

NOTE: When using current inputs, the TELEFAST 250 Ohm resistors are used, as opposed to those of the module. The BMX AMI 0410 module operates in voltage mode.

Connecting Sensors

Sensors may be connected to the ABE-7CPA410 accessory as shown in the illustration. *(see page 71)*

The following table shows the ABE7-CPA410 and SUBD25 terminal numbers:

Terminal Numbers	SUBD25	Description	Terminal Numbers	SUBD25	Description
1	/	Earth	/		24 VDC Input
2	/	Earth	/		24 VDC Input
3	/	Earth	/		0V24 Input
4	/	COM 0	/		0V24 Input
100		Output IS 0	101	14	COM 0V0
102		Output IS 1	103	3	COM 0V1
104		Output IS 2	105	17	COM 0V2
106		Output IS 3	107	6	COM 0V3
200	1	Output IV 0	201		Input IC 0
202	15	Output IV 1	203		Input IC 1
204	4	Output IV 2	205		Input IC 2
206	18	Output IV 3	207		Input IC 3

Wiring diagram:

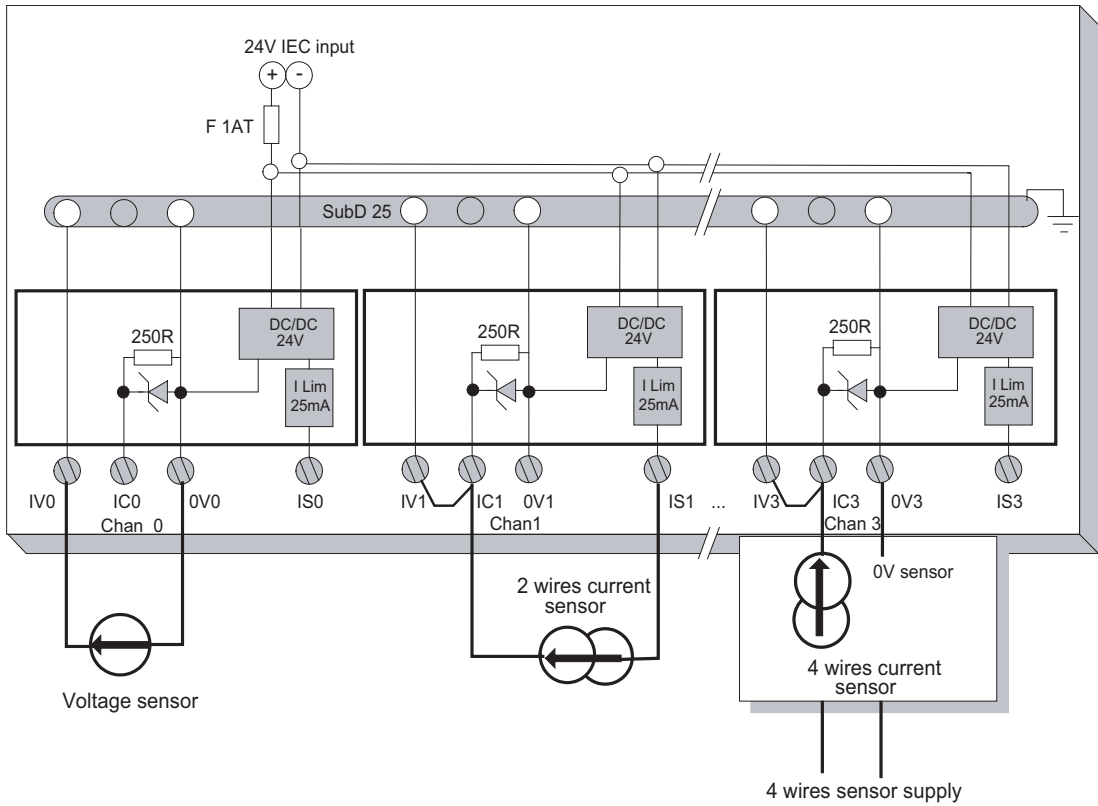

Connecting Modules

Modules can be connected to a TELEFAST ABE-7CPA410 as shown in the diagram below.

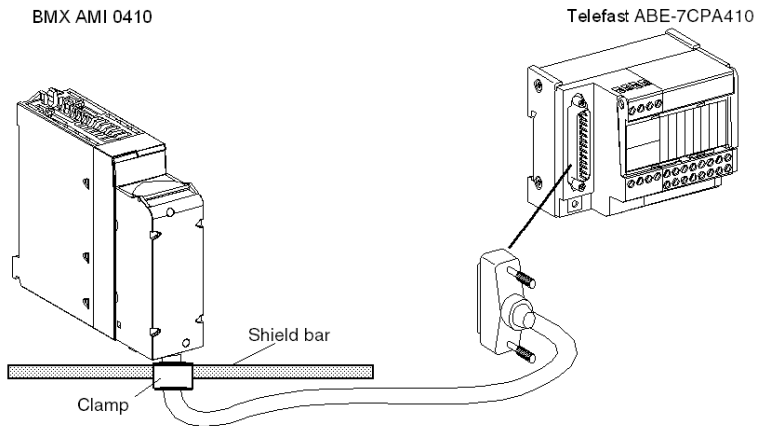

The BMX AMI 0410 analog module may be connected to the TELEFAST ABE-7CPA410 accessory using one of the following cables:

- BMX FCA 150: length 1.5 m
- BMX FCA 300: length 3 m
- BMX FCA 500: length 5 m

Chapter 4

BMX AMI 0800 Analog Input Module

Subject of this Chapter

This chapter presents the BMX AMI 0800 module, its characteristics, and explains how it is connected to the various sensors.

What Is in This Chapter?

This chapter contains the following topics:

Topic	Page
Presentation	80
Characteristics	81
Functional Description	83
Wiring Precautions	91
Wiring Diagram	94
Use of the TELEFAST ABE-7CPA02/03/31E Wiring Accessory	96

Presentation

Function

The BMX AMI 0800 is a high density input analog module with 8 non-isolated channels.

This module is used in conjunction with sensors or transmitters; it performs monitoring, measurement, and continuous process control functions.

The BMX AMI 0800 module offers the following range for each input according to the selection made during configuration:

- Voltage +/-5 V/+/-10 V/0..5 V/0..10 V/1..5 V
- Current +/-20 mA/0..20 mA/4..20 mA

The module operates with voltage inputs. It includes eight read resistors connected to the terminal block to perform current inputs.

Illustration

The following graphic shows the BMX AMI 0800 analog input module:

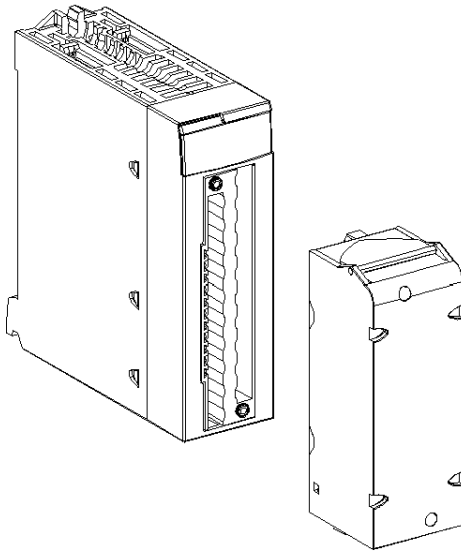

NOTE: The terminal block is supplied separately.

Characteristics

General Characteristics

The general characteristics for the BMX AMI 0800 and BMX AMI 0800H modules are as follows:

Type of inputs		High level Fast inputs with common point
Nature of inputs		Voltage / Current
Number of channels		8
Acquisition cycle time:		
<ul style="list-style-type: none"> Fast (periodic acquisition for the declared channels used) 		1 ms + 1 ms x number of channels used
<ul style="list-style-type: none"> Default (periodic acquisition for all channels) 		9 ms
Display resolution		16-bit
Digital filtering		First order
Isolation:		
<ul style="list-style-type: none"> Between channels 		Non-isolated
<ul style="list-style-type: none"> Between channels and bus 		1400 VDC
<ul style="list-style-type: none"> Between channels and ground 		1400 VDC
Maximum overload authorized for inputs:		Voltage inputs: +/- 30 VDC Current inputs: +/- 30 mA
Power consumption (3.3 V)	Typical	0.32 W
	Maximum	0.48 W
Power consumption (24 V)	Typical	0.55 W
	Maximum	1.01 W

Measurement Range

The BMX AMI 0800 and BMX AMI 0800H analog inputs have the following measurement range characteristics:

Measurement range	+/-10 V; +/-5 V; 0..10 V; 0.5 V; 1..5 V	+/-20 mA; 0..20 mA; 4..20 mA
Maximum conversion value	+/-11.4 V	+/-30 mA
Conversion resolution	0.36 mV	1.4 µA
Input impedance	10 MΩ	250 Ω Internal conversion resistor
Precision of the internal conversion resistor	-	0.1% - 15 ppm/°C
Measurement errors for standard module:		
<ul style="list-style-type: none"> At 25°C Maximum in the temperature range 0...60°C (32...140°F) 	0.075% of FS (1) 0.1% of FS (1)	Typical 0.15% of FS (1)(2) 0.3% of FS (1)(2)
Measurement errors for Hardened module:		
<ul style="list-style-type: none"> At 25°C Maximum in the temperature range -25...70°C (-13...158°F) 	0.075% of FS (1) 0.2% of FS (1)	Typical 0.15% of FS (1)(2) 0.55% of FS (1)(2)
Temperature drift	30 ppm/°C	50 ppm/°C including conversion resistance
Monotonicity	Yes	Yes
Crosstalk between channels DC and AC 50/60Hz	> 80dB	> 80dB
Non-linearity	0.001%	0.001%
Repeatability @25°C of 10 min. stabilization time	0.005% of FS	0.007% of FS
Long term stability after 1000 hours	< 0.004% of FS	< 0.004% of FS
Legend:		
(1) FS: Full Scale		
(2) With conversion resistor error		

NOTE: If nothing is connected on a BMX AMI 0800 and BMX AMI 0800H analog module and if channels are configured (range of 4..20 mA or 1..5 V), there is a detected I/O error as if a wire is broken.

Functional Description

Function

The BMX AMI 0800 module is a high density input analog module with 8 non-input channel.

This module is used in conjunction with sensors or transmitters; it performs monitoring, measurement, and continuous process control functions.

The BMX AMI 0800 module offers the following range for each input according to the selection made during configuration:

- +/-10 V
- 0..10 V
- 0..5 V / 0..20 mA
- 1..5 V / 4..20 mA
- +/-5 V / +/-20 mA

The module operates with voltage inputs. It includes eight read resistors connected to the terminal block to perform current inputs.

Illustration

The BMX AMI 0800 module's illustration:

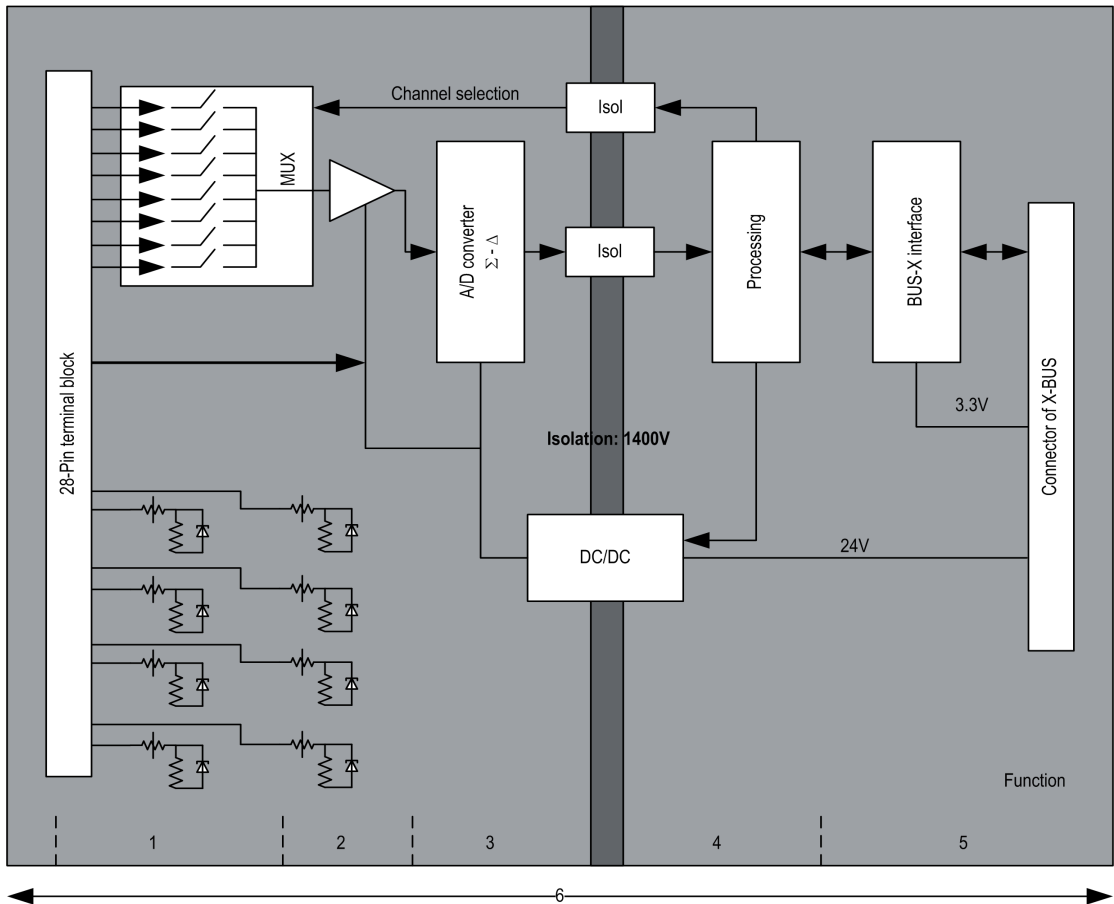

Description:

No.	Process	Function
1	Adapting the Inputs and Multiplexing	<ul style="list-style-type: none"> ● Physical connection to the process through a 28-pin screw terminal block ● Protection of the module against overvoltages ● Input signal analog filtering
2	Amplifying Input Signals	<ul style="list-style-type: none"> ● Gain selecting, based on characteristics of input signals, as defined during configuration (unipolar or bipolar range, in voltage or current) ● Compensation of drift in amplifier device
3	Converting	<ul style="list-style-type: none"> ● Conversion of analog Input signal into digital 24-bit signal using a $\Sigma\Delta$ converter
4	Transforming incoming values into workable measurements for the user.	<ul style="list-style-type: none"> ● Takes into account recalibration and alignment coefficients to be applied to measurements, as well as the module's self-calibration coefficients ● (Numeric) filtering for measurements, based on configuration parameters ● Scaling of measurements, based on configuration parameters
5	Communicating with the Application	<ul style="list-style-type: none"> ● Manages exchanges with CPU ● Topological addressing ● Receives configuration parameters from module and channels ● Sends measured values, as well as module status, to application
6	Module monitoring and sending error notification back to application.	Conversion string test Testing for range overflow on channels Watchdog test

Measurement Timing

The timing of measurements is determined by the cycle selected during configuration (Normal or Fast Cycle):

- Normal Cycle means that the scan cycle duration is fixed.
- With the Fast Cycle, however, the system only scans the channels designated as being In Use. The scan cycle duration is therefore proportional to the number of channels In Use.

The cycle time values are based on the cycle selected:

Module	Normal Cycle	Fast Cycle
BMX AMI 0800	9 ms	1 ms + (1 ms x N) where N: number of channels in use.

NOTE: Module cycle is not synchronized with the PLC cycle. At the beginning of each PLC cycle, each channel value is taken into account. If the MAST/FAST task cycle time is less than the module's cycle time, some values will not have changed.

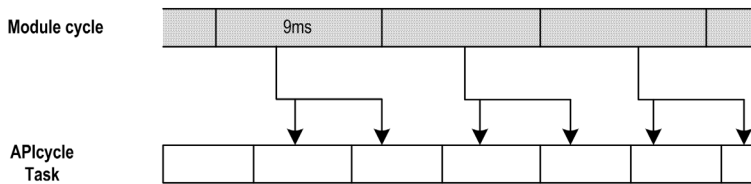

Overflow/Underflow Control

Module BMX AMI 0800 allows the user to select between 6 voltage or current ranges for each input.

This option for each channel have to be configured in configuration windows. Upper and lower tolerance detection are always active regardless of overflow/underflow control.

Depending on the range selected the module checks for overflow, it verifies that the measurement falls between a lower and an upper threshold:

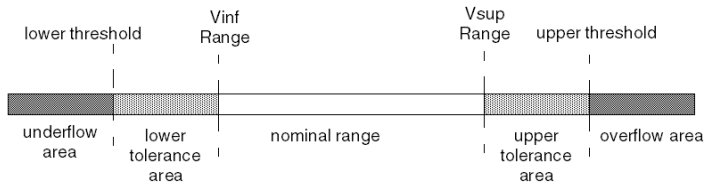

Description:

Designation	Description
Nominal range	measurement range corresponding to the chosen range
Upper Tolerance Area	varies between the values included between the maximum value for the range (for instance: +10 V for the +/-10 V range) and the upper threshold
Lower Tolerance Area	varies between the values included between the minimum value for the range (for instance: -10 V for the +/-10 V range) and the lower threshold
Overflow Area	area located beyond the upper threshold
Underflow Area	area located below the lower threshold

The values of the thresholds are configurable independently from one another. They may assume integer values between the following limits:

Range	BMX AMI 0800 Range									
	Underflow Area		Lower Tolerance Area		Nominal Range		Upper Tolerance Area		Overflow Area	
Unipolar										
0...10 V	-1,500	-1,001	-1,000	-1	0	10,000	10,001	11,000	11,001	11,400
0...5 V / 0...20 mA	-5,000	-1,001	-1,000	-1	0	10,000	10,001	11,000	11,001	15,000
1...5 V / 4...20 mA	-4,000	-801	-800	-1	0	10,000	10,001	10,800	10,801	14,000
Bipolar										
+/- 10 V	-11,500	-11,001	-11,000	-10,001	-10,000	10,000	10,001	11,000	11,001	11,400
+/- 5 V, +/- 20 mA	-15,000	-11,001	-11,000	-10,001	-10,000	10,000	10,001	11,000	11,001	15,000
User										
+/- 10 V	-32,768				User-defined	User-defined				32,767
0...10 V	-32,768				User-defined	User-defined				32,767

Measurement Display

Measurements may be displayed using standardized display (in %, to two decimal places):

Type of Range	Display
Unipolar range 0...10 V, 0...5 V, 1...5 V, 0...20mA, 4...20mA	from 0 to 10,000 (0 % at +100.00 %)
Bipolar range +/- 10 V, +/- 5 mV +/- 20 mA	from -10,000 to 10,000 (-100.00 % at +100.00 %)

It is also possible to define the range of values within which measurements are expressed, by selecting:

- the lower threshold corresponding to the minimum value for the range: 0% (or -100.00 %).
- the upper threshold corresponding to the maximum value for the range (+100.00%).

The lower and upper thresholds must be integers between -32,768 and +32,767.

For example, imagine a conditioner providing pressure data on a 4-20 mA loop, with 4 mA corresponding to 3,200 millibar and 20 mA corresponding to 9,600 millibar. You have the option of choosing the User format, by setting the following lower and upper thresholds:

3,200 for 3,200 millibar as the lower threshold

9,600 for 9,600 millibar as the upper threshold

Values transmitted to the program vary between 3,200 (= 4 mA) and 9,600 (= 20 mA).

Measurement Filtering

The type of filtering performed by the system is called "first order filtering". The filtering coefficient can be modified from a programming console or via the program.

The mathematical formula used is as follows:

$$Meas_{f(n)} = \alpha \times Meas_{f(n-1)} + (1 - \alpha) \times Val_{b(n)}$$

where:

α = efficiency of the filter

$Meas_{f(n)}$ = measurement filtered at moment n

$Meas_{f(n-1)}$ = measurement filtered at moment n-1

$Val_{b(n)}$ = gross value at moment n

You may configure the filtering value from 7 possibilities (from 0 to 6). This value may be changed even when the application is in RUN mode.

NOTE: Filtering may be accessed in Normal or Fast Cycle.

The filtering values depend on the T configuration cycle (where T = cycle time of 5 ms in standard mode):

Desired Efficiency	Required Value	Corresponding α	Filter Response Time at 63%	Cut-off Frequency (in Hz)
No filtering	0	0	0	0
Low filtering	1	0.750	4 x T	0.040 / T
	2	0.875	8 x T	0.020 / T
Medium filtering	3	0.937	16 x T	0.010 / T
	4	0.969	32 x T	0.005 / T
High filtering	5	0.984	64 x T	0.0025 / T
	6	0.992	128 x T	0.0012 / T

Sensor Alignment

The process of "alignment" consists in eliminating a systematic offset observed with a given sensor, around a specific operating point. This operation compensates for an error linked to the process. Replacing a module does not therefore require a new alignment. However, replacing the sensor or changing the sensor's operating point does require a new alignment.

Conversion lines are as follows:

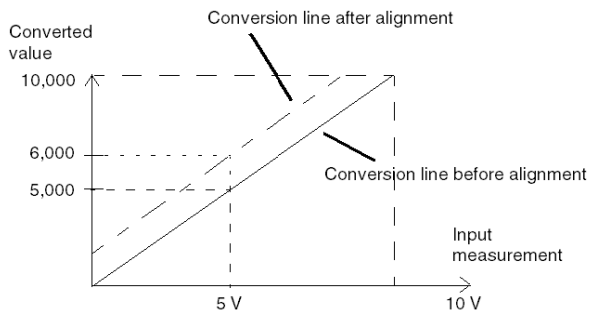

The alignment value is editable from a programming console, even if the program is in RUN Mode. For each input channel, you can:

- view and modify the desired measurement value
- save the alignment value
- determine whether the channel already has an alignment

The alignment offset may also be modified through programming.

Channel alignment is performed on the channel in standard operating mode, without any effect on the channel's operating modes.

The maximum offset between measured value and desired (aligned) value may not exceed +/- 1.500.

NOTE: To align several analog channels on the BMX ART/AMO/AMI/AMM modules, we recommend proceeding channel by channel. Test each channel after alignment before moving to the next channel in order to apply the parameters correctly.

Wiring Precautions

Introduction

In order to protect the signal from outside interference induced in series mode and interference in common mode, we recommend that you take the following precautions.

Cable Shielding

Connect the cable shielding to the grounding bar. Clamp the shielding to the grounding bar on the module side. Use the shielding connection kit BMXXSP**** (see page 50) to connect the shielding.

⚠ DANGER

HAZARD OF ELECTRIC SHOCK, EXPLOSION, OR ARC FLASH

While mounting / removing the modules:

- make sure that each terminal block is still connected to the shield bar and
- disconnect voltage supplying sensors and pre-actuators.

Failure to follow these instructions will result in death or serious injury.

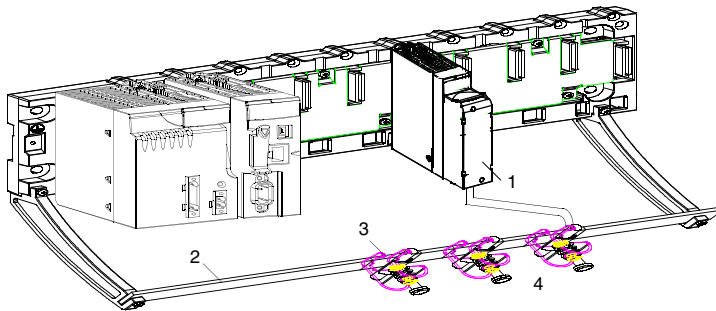

- 1 BMX AMI 0800
- 2 Shield bar
- 3 Clamp
- 4 To sensors

Reference of Sensors in Relation to the Ground

In order for the acquisition system to operate correctly, It is recommended to take in account the following precautions:

- sensors must be close together (a few meters)
- all sensors must be referenced to a single point, which is connected to the PLC's ground

Using the Sensors Referenced in Relation to the Ground

The sensors are connected as indicated in the following diagram:

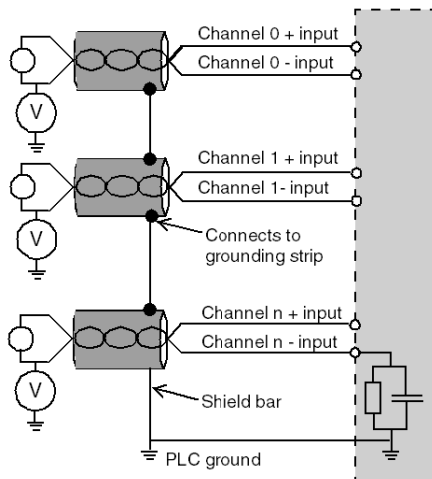

If the sensors are referenced in relation to the ground, this may in some cases return a remote ground potential to the terminal block. It is therefore **essential** to follow the following rules:

- The potential must be less than the permitted low voltage: for example, 30 Vrms or 42.4 VDC.
- Setting a sensor point to a reference potential generates a leakage current. You must therefore check that all leakage currents generated do not disturb the system.

⚠ DANGER

HAZARD OF ELECTRIC SHOCK

Sensors and other peripherals may be connected to a grounding point some distance from the module. Such remote ground references may carry considerable potential differences with respect to local ground.

Ensure that:

- potentials greater than permitted low limits cannot exist,
- induced currents do not affect the measurement or integrity of the system.

Failure to follow these instructions will result in death or serious injury.

Electromagnetic Hazard Instructions

CAUTION

UNEXPECTED BEHAVIOR OF APPLICATION

Follow those instructions to reduce electromagnetic perturbations:

- use the shielding connection kit BMXXSP•••• (*see page 50*) to connect the shielding.

Electromagnetic perturbations may lead to an unexpected behavior of the application.

Failure to follow these instructions can result in injury or equipment damage.

Wiring Diagram

Introduction

Module BMX AMI 0800 is connected using the 28-pin terminal block.

Illustration

The terminal block connection and the sensor wiring are as follows:

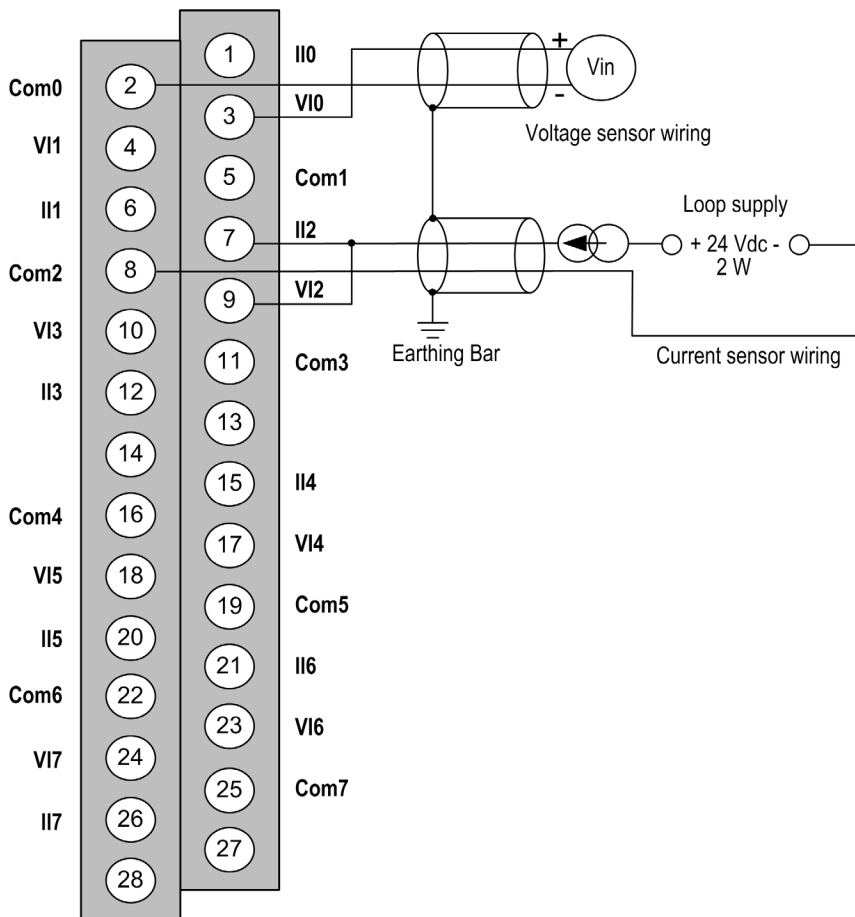

VIx + pole input for channel x.

COMx - pole input for channel x, COMx are connected together internally.

IIx current reading resistor + input.

Channel 0 voltage sensor.

Channel 1 2-wire current sensor.

Wiring Accessories

For rapid connection to operative parts, the module can be connected to a TELEFAST pre-wired system (*see page 96*).

Use of the TELEFAST ABE-7CPA02/03/31E Wiring Accessory

Introduction

The TELEFAST pre-wired system consists of connecting cables and interface sub-bases as shown below:

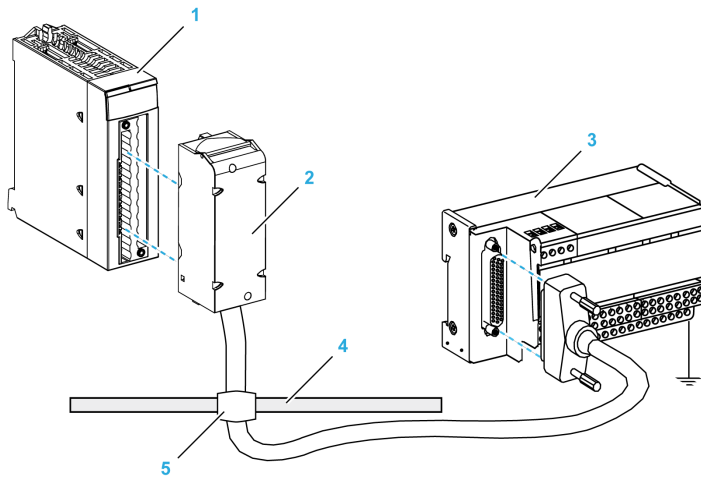

- 1 BMX AMI 0800
- 2 Connecting cable
- 3 Interface sub-base
- 4 Shield bar
- 5 Clamp

The BMX AMI 0800 module can be connected to the following references:

Connecting cables:

- BMXFTA150 (1.5 m (4.92 ft))
- BMXFTA300 (3 m (9.84 ft))

Interface sub-bases:

- ABE-7CPA02
- ABE-7CPA03
- ABE-7CPA31
- ABE-7CPA31E

NOTE: In case HART information is part of the signal to be measured, an ABE-7CPA31E interface sub-base has to be used in order to filter this information that would disrupt the analog value.

ABE-7CPA02 Sensor Connection

The following table shows the distribution of analog channels on TELEFAST 2 terminal blocks with the interface sub-base ABE-7CPA02:

TELEFAST 2 terminal block number	25-pin Sub-D connector pin number	AMI08x0 pin out	Signal type	TELEFAST 2 terminal block number	25-pin Sub-D connector pin number	AMI08x0 pin out	Signal type
1	/		Ground	Supp 1	/		Ground
2	/		STD (1)	Supp 2	/		Ground
3	/		STD (1)	Supp 3	/		Ground
4	/		STD (2)	Supp 4	/		Ground
100	1	3	+IV0	200	14	2	COM0
101	2	1	+IC0	201	/		Ground
102	15	4	+IV1	202	3	5	COM1
103	16	6	+IC1	203	/		Ground
104	4	9	+IV2	204	17	8	COM2
105	5	7	+IC2	205	/		Ground
106	18	10	+IV3	206	6	11	COM3
107	19	12	+IC3	207	/		Ground
108	7	17	+IV4	208	20	16	COM4
109	8	15	+IC4	209	/		Ground
110	21	18	+IV5	210	9	19	COM5
111	22	20	+IC5	211	/		Ground
112	10	23	+IV6	212	23	22	COM6
113	11	21	+IC6	213	/		Ground
114	24	24	+IV7	214	12	25	COM7
115	25	26	+IC7	215	/		Ground

NOTE: On the ABE-7CPA02, the strap position is between pin 1 and pin 2.

+IVx: + pole voltage input for channel x.

+ICx: + pole current input for channel x.

COMx: - pole voltage or current input for channel x.

NOTE: For current sensors connected on the TELEFAST 2 ABE-7CPA02, a strap must be made on the BMX AMI 0800 terminal block between the current input and the voltage input as illustrated below.

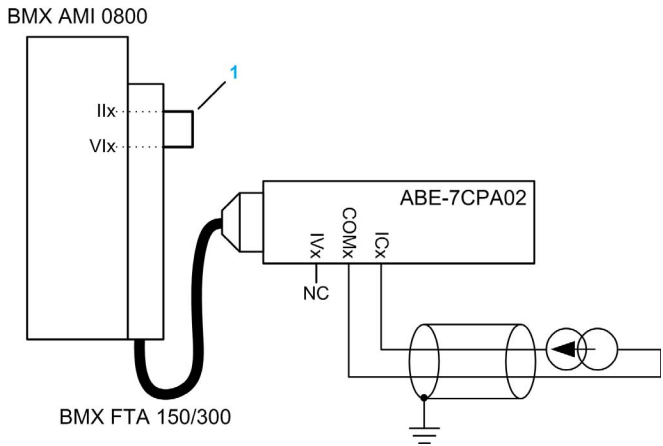

- 1 Strap on the terminal block.

NOTE: For the ground connection use the additional terminal block ABE-7BV10/20.

ABE-7CPA03 Sensor Connection

The negative current is not supported by ABE-7CPA03

NOTICE

EQUIPMENT DAMAGE

Do not apply a negative current when BMX AMI 0800 is associated with ABE-7CPA03.

Failure to follow these instructions can result in equipment damage.

The following table shows the distribution of analog channels on TELEFAST 2 terminal blocks with the reference ABE-7CPA03:

TELEFAST 2 terminal block number	25-pin Sub-D connector pin number	AMI0800 pin out	Signal type	TELEFAST 2 terminal block number	25-pin Sub-D connector pin number	AMI0800 pin out	Signal type
1	/		0 V	Supp 1	/		24 V (sensor supply)
2	/		0 V	Supp 2	/		24 V (sensor supply)
3	/		0 V	Supp 3	/		0 V (sensor supply)
4	/		0 V	Supp 4	/		0 V (sensor supply)
100	/		+IS1	200	/		+IS0
101	15	4	+IV1	201	1	3	+IV0
102	16	6	+IC1	202	2	1	+IC0
103	/		Ground	203	14/3	2/5	COM0/COM1
104	/		+IS3	204	/		+IS2
105	18	10	+IV3	205	4	9	+IV2
106	19	12	+IC3	206	5	7	+IC2
107	/		Ground	207	17/6	8/11	COM2/COM3
108	/		+IS5	208	/		+IS4
109	21	18	+IV5	209	7	17	+IV4
110	22	20	+IC5	210	8	15	+IC4
111	/		Ground	211	20/9	16/19	COM4/COM5
112	/		+IS7	212	/		+IS6
113	24	24	+IV7	213	10	21	+IV6
114	25	26	+IC7	214	11	23	+IC6
115	/		Ground	215	23/12	22/25	COM6/COM7

+ISx: 24 V channel power supply
+IVx: + pole voltage input for channel x
+ICx: + pole current input for channel x
COMx: - pole voltage or current input for channel x

NOTE: For current sensors connected on the TELEFAST 2 ABE-7CPA03, a strap must be made on the BMX AMI 0800 terminal block between the current input and the voltage input as illustrated below.

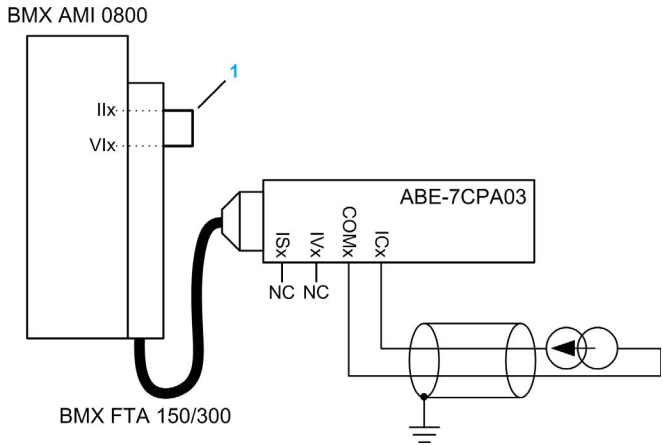

- 1 Strap on the terminal block.

NOTE: For the ground connection use the additional terminal block ABE-7BV10/20.

ABE-7CPA031E Sensor Connection

The following table shows the distribution of analog channels on TELEFAST 2 terminal blocks with the reference ABE-7CPA31E:

TELEFAST 2 terminal block number	Terminal	Signal type	TELEFAST 2 terminal block number	Terminal	Signal type
1	/	Ground	Supp 1	/	24 V (sensor supply)
2	/	Ground	Supp 2	/	24 V (sensor supply)
3	/	Ground	Supp 3	/	0 V (sensor supply)
4	/	Ground	Supp 4	/	0 V (sensor supply)
100	/	+IS0	116	/	+IS4
101	/	T0	117	/	T4
<p>+ISx: 24 V channel power supply Tx: Reserved test pin for HART function, it's internally connected with +ICx +ICx: + pole current input for channel x COMx: - pole voltage or current input for channel x</p>					

TELEFAST 2 terminal block number	Terminal	Signal type	TELEFAST 2 terminal block number	Terminal	Signal type
102	/	+IC0	118	/	+IC4
103	/	0V0	119	/	0V4
104	/	+IS1	120	/	+IS5
105	/	T1	121	/	T5
106	/	+IC1	122	/	+IC5
107	/	0V1	123	/	0V5
108	/	+IS2	124	/	+IS6
109	/	T2	125	/	T6
110	/	+IC2	126	/	+IC6
111	/	0V2	127	/	0V6
112	/	+IS3	128	/	+IS7
113	/	T3	129	/	T7
114	/	+IC3	130	/	+IC7
115	/	0V3	131	/	0V7
<p>+ISx: 24 V channel power supply Tx: Reserved test pin for HART function, it's internally connected with +ICx +ICx: + pole current input for channel x COMx: - pole voltage or current input for channel x</p>					

NOTE: For the ground connection use the additional terminal block ABE-7BV10/20.

Chapter 5

BMX AMI 0810 Analog Input Module

Subject of this Chapter

This chapter presents the BMX AMI 0810 module, its characteristics, and explains how it is connected to the various sensors.

What Is in This Chapter?

This chapter contains the following topics:

Topic	Page
Presentation	104
Characteristics	105
Functional Description	107
Wiring Precautions	114
Wiring Diagram	117
Use of the TELEFAST ABE-7CPA02/31/31E Wiring Accessory	119

Presentation

Function

The BMX AMI 0810 is a high density input analog module with 8 isolated channels.

This module is used in conjunction with sensors or transmitters; it performs monitoring, measurement, and continuous process control functions.

The BMX AMI 0810 module offers the following range for each input according to the selection made during configuration:

- Voltage +/-5 V/+/-10 V/0..5 V/0..10 V/1..5 V
- Current +/-20 mA/0..20 mA/4..20 mA

The module operates with voltage inputs. It includes eight read resistors connected to the terminal block to perform current inputs.

Illustration

The following graphic shows the BMX AMI 0810 analog input module:

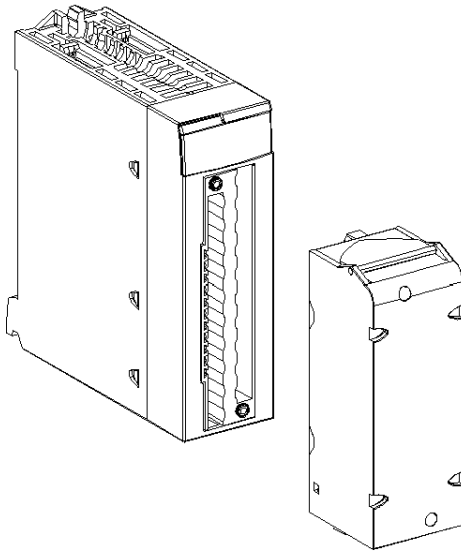

NOTE: The terminal block is supplied separately.

Characteristics

General Characteristics

The general characteristics for the BMX AMI 0810 and BMX AMI 0810H modules are as follows:

Type of inputs		High level isolated fast inputs
Nature of inputs		Voltage / Current
Number of channels		8
Acquisition cycle time:		
<ul style="list-style-type: none"> Fast (periodic acquisition for the declared channels used) 		1 ms + 1 ms x number of channels used
<ul style="list-style-type: none"> Default (periodic acquisition for all channels) 		9 ms
Display resolution		16-bit
Digital filtering		First order
Isolation:		
<ul style="list-style-type: none"> Between channels 		+/-300 VDC
<ul style="list-style-type: none"> Between channels and bus 		1400 VDC
<ul style="list-style-type: none"> Between channels and ground 		1400 VDC
Maximum overload authorized for inputs:		Voltage inputs: +/- 30 VDC Current inputs: +/- 30 mA Protected against accidental wiring: -19.2 to 30VDC NOTE: The Protected for accidental wiring function is not supported when the module works with any Telefast interface.
Power consumption (3.3 V)	Typical	0.32 W
	Maximum	0.48 W
Power consumption (24 V)	Typical	0.82 W
	Maximum	1.30 W

Measurement Range

The BMX AMI 0810 and BMX AMI 0810H analog inputs have the following measurement range characteristics:

Measurement range	+/-10 V; +/-5 V; 0..10 V; 0..5 V; 1..5 V	+/-20 mA; 0..20 mA; 4..20 mA
Maximum conversion value	+/-11.4 V	+/-30 mA
Conversion resolution	0.36 mV	1.4 μ A
Input impedance	10 M Ω	Internal conversion resistor (250 Ω) + Internal protection resistor (see note)
Precision of the internal conversion resistor	-	0.1% - 15 ppm/ $^{\circ}$ C
Measurement errors for standard module:		
<ul style="list-style-type: none"> At 25$^{\circ}$C Maximum in the temperature range 0...60$^{\circ}$C (32...140$^{\circ}$F) 	0.075% of FS (1) 0.1% of FS (1)	Typical 0.15% of FS (1)(2) 0.3% of FS (1)(2)
Measurement errors for Hardened module:		
<ul style="list-style-type: none"> At 25$^{\circ}$C Maximum in the temperature range -25...70$^{\circ}$C (-13...158$^{\circ}$F) 	0.075% of FS (1) 0.2% of FS (1)	Typical 0.15% of FS (1)(2) 0.55% of FS (1)(2)
Temperature drift	30 ppm/ $^{\circ}$ C	50 ppm/ $^{\circ}$ C
Monotonicity	Yes	Yes
Crosstalk between channels DC and AC 50/60Hz	> 80dB	> 80dB
Non-linearity	0.001%	0.001%
Repeatability @25 $^{\circ}$ C of 10 min. stabilization time	0.005% of FS	0.007% of FS
Long term stability after 1000 hours	< 0.004% of FS	< 0.004% of FS
Legend:		
(1) FS: Full Scale		
(2) With conversion resistor error		

NOTE: The internal protection resistor has a typical impedance of 25 Ω (min 3.6 Ω and max 50 Ω), The precision of the protection resistor does not impact the measured value.

NOTE: If nothing is connected on a BMX AMI 0810 and BMX AMI 0810H analog module and if channels are configured (range 4..20 mA or 1..5 V), there is a detected I/O error as if a wire is broken.

Functional Description

Function

The BMX AMI 0810 is a high density input analog module with 8 isolated channels.

This module is used in conjunction with sensors or transmitters; it performs monitoring, measurement, and continuous process control functions.

The BMX AMI 0810 module offers the following range for each input according to the selection made during configuration:

- +/-10 V
- 0..10 V
- 0..5 V / 0..20 mA
- 1..5 V / 4..20 mA
- +/-5 V / +/-20 mA

The module operates with voltage inputs. It includes eight read resistors connected to the terminal block to perform current inputs.

Illustration

The BMX AMI 0810 illustration:

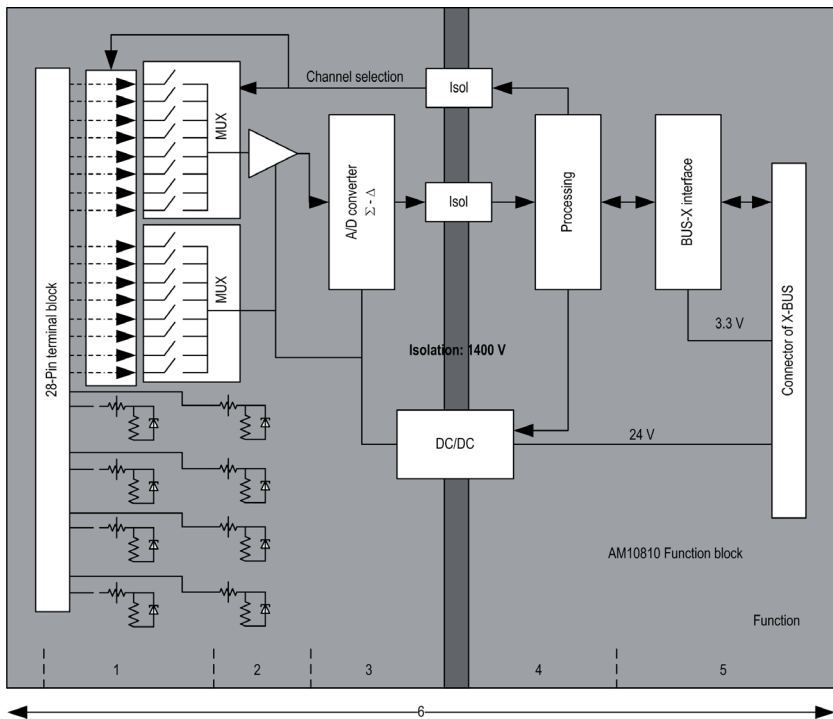

Description:

No.	Process	Function
1	Adapting the Inputs and Multiplexing	<ul style="list-style-type: none"> Physical connection to the process through a 28-pin screw terminal block Protection of the module against overvoltages Protection of the current reading resistors using limiters and resettable fuses Input signal analog filtering Scan input channels using static multiplexing through opto-switches, in order to provide the possibility of common mode voltage of +/- 300 Vdc
2	Amplifying Input Signals	<ul style="list-style-type: none"> Gain selecting , based on characteristics of input signals, as defined during configuration (unipolar or bipolar range, in voltage or current) Compensation of drift in amplifier device
3	Converting	<ul style="list-style-type: none"> Conversion of analog Input signal into digital 24-bit signal using a $\Sigma\Delta$ converter

No.	Process	Function
4	Transforming incoming values into workable measurements for the user.	<ul style="list-style-type: none"> • Takes into account recalibration and alignment coefficients to be applied to measurements and the module's self-calibration coefficients • (Numeric) filtering of measurements, based on configuration parameters • Scaling of measurements, based on configuration parameters
5	Communicating with the Application	<ul style="list-style-type: none"> • Manages exchanges with CPU • Topological addressing • Receives configuration parameters from module and channels • Sends measured values, as well as module status, to application
6	Module monitoring and sending error notification back to application.	Conversion string test Testing for range overflow on channels Watchdog test

Measurement Timing

The timing of measurements is determined by the cycle selected during configuration (Normal or Fast Cycle):

- Normal Cycle means that the scan cycle duration is fixed.
- With the Fast Cycle, however, the system only scans the channels designated as being In Use. The scan cycle duration is therefore proportional to the number of channels In Use.

The cycle time values are based on the cycle selected:

Module	Normal Cycle	Fast Cycle
BMX AMI 0810	9 ms	1 ms + (1 ms x N) where N: number of channels in use.

NOTE: Module cycle is not synchronized with the PLC cycle. At the beginning of each PLC cycle, each channel value is taken into account. If the MAST/FAST task cycle time is less than the module's cycle time, some values will not have changed.

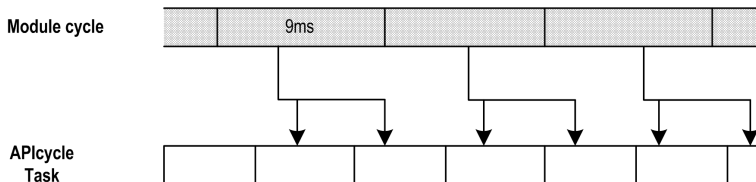

Overflow/Underflow Control

Module BMX AMI 0810 allows the user to select between 6 voltage or current ranges for each input.

This option for each channel have to be configured in configuration windows. Upper and lower tolerance detection are always active regardless of overflow/underflow control.

Depending on the range selected the module checks for overflow, it verifies that the measurement falls between a lower and an upper threshold:

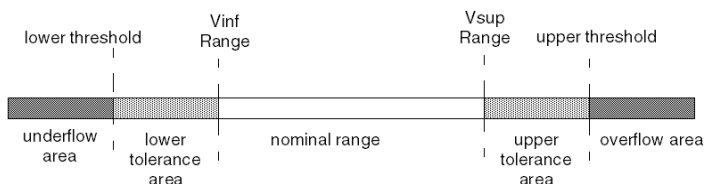

Description:

Designation	Description
Nominal range	measurement range corresponding to the chosen range
Upper Tolerance Area	varies between the values included between the maximum value for the range (for instance: +10 V for the +/-10 V range) and the upper threshold
Lower Tolerance Area	varies between the values included between the minimum value for the range (for instance: -10 V for the +/-10 V range) and the lower threshold
Overflow Area	area located beyond the upper threshold
Underflow Area	area located below the lower threshold

The values of the thresholds are configurable independently from one another. They may assume integer values between the following limits:

Range	BMX AMI 0810 Range									
	Underflow Area		Lower Tolerance Area	Nominal Range		Upper Tolerance Area	Overflow Area			
Unipolar										
0...10 V	-1,500	-1,001	-1,000	-1	0	10,000	10,001	11,000	11,001	11,400
0...5 V / 0...20 mA	-5,000	-1,001	-1,000	-1	0	10,000	10,001	11,000	11,001	15,000
1...5 V / 4...20 mA	-4,000	-801	-800	-1	0	10,000	10,001	10,800	10,801	14,000
Bipolar										

Range	BMX AMI 0810 Range									
	Underflow Area		Lower Tolerance Area		Nominal Range		Upper Tolerance Area		Overflow Area	
+/- 10 V	-11,500	-11,001	-11,000	-10,001	-10,000	10,000	10,001	11,000	11,001	11,400
+/- 5 V, +/- 20 mA	-15,000	-11,001	-11,000	-10,001	-10,000	10,000	10,001	11,000	11,001	15,000
User										
+/- 10 V	-32,768				User-defined	User-defined				32,767
0...10 V	-32,768				User-defined	User-defined				32,767

Measurement Display

Measurements may be displayed using standardized display (in %, to two decimal places):

Type of Range	Display
Unipolar range 0...10 V, 0...5 V, 1...5 V, 0...20mA, 4...20mA	from 0 to 10,000 (0 % at +100.00 %)
Bipolar range +/- 10 V, +/- 5 mV +/- 20 mA	from -10,000 to 10,000 (-100.00 % at +100.00 %)

It is also possible to define the range of values within which measurements are expressed, by selecting:

- the lower threshold corresponding to the minimum value for the range: 0 % (or -100.00 %).
- the upper threshold corresponding to the maximum value for the range (+100.00 %).

The lower and upper thresholds must be integers between -32,768 and +32,767.

For example, imagine a conditioner providing pressure data on a 4-20 mA loop, with 4 mA corresponding to 3,200 millibar and 20 mA corresponding to 9,600 millibar. You have the option of choosing the User format, by setting the following lower and upper thresholds:

3,200 for 3,200 millibar as the lower threshold

9,600 for 9,600 millibar as the upper threshold

Values transmitted to the program vary between 3,200 (= 4 mA) and 9,600 (= 20 mA).

Measurement Filtering

The type of filtering performed by the system is called "first order filtering". The filtering coefficient can be modified from a programming console or via the program.

The mathematical formula used is as follows:

$$Meas_{f(n)} = \alpha \times Meas_{f(n-1)} + (1 - \alpha) \times Val_{b(n)}$$

where:

α = efficiency of the filter

$Meas_{f(n)}$ = measurement filtered at moment n

$Meas_{f(n-1)}$ = measurement filtered at moment n-1

$Val_{b(n)}$ = gross value at moment n

You may configure the filtering value from 7 possibilities (from 0 to 6). This value may be changed even when the application is in RUN mode.

NOTE: Filtering may be accessed in Normal or Fast Cycle.

The filtering values depend on the T configuration cycle (where T = cycle time of 5 ms in standard mode):

Desired Efficiency	Required Value	Corresponding α	Filter Response Time at 63%	Cut-off Frequency (in Hz)
No filtering	0	0	0	0
Low filtering	1	0.750	4 x T	0.040 / T
	2	0.875	8 x T	0.020 / T
Medium filtering	3	0.937	16 x T	0.010 / T
	4	0.969	32 x T	0.005 / T
High filtering	5	0.984	64 x T	0.0025 / T
	6	0.992	128 x T	0.0012 / T

Sensor Alignment

The process of "alignment" consists in eliminating a systematic offset observed with a given sensor, around a specific operating point. This operation compensates for an error linked to the process. Replacing a module does not therefore require a new alignment. However, replacing the sensor or changing the sensor's operating point does require a new alignment.

Conversion lines are as follows:

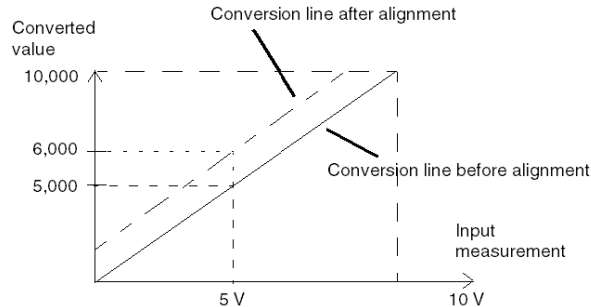

The alignment value is editable from a programming console, even if the program is in RUN Mode. For each input channel, you can:

- view and modify the desired measurement value
- save the alignment value
- determine whether the channel already has an alignment

The alignment offset may also be modified through programming.

Channel alignment is performed on the channel in standard operating mode, without any effect on the channel's operating modes.

The maximum offset between measured value and desired (aligned) value may not exceed +/- 1.500.

NOTE: To align several analog channels on the BMX ART/AMO/AMI/AMM modules, we recommend proceeding channel by channel. Test each channel after alignment before moving to the next channel in order to apply the parameters correctly.

Wiring Precautions

Introduction

In order to protect the signal from outside interference induced in series mode and interference in common mode, we recommend that you take the following precautions.

Cable Shielding

Connect the cable shielding to the grounding bar. Clamp the shielding to the grounding bar on the module side. Use the shielding connection kit BMXXSP**** (see page 50) to connect the shielding.

⚠ DANGER

HAZARD OF ELECTRIC SHOCK, EXPLOSION, OR ARC FLASH

While mounting / removing the modules:

- make sure that each terminal block is still connected to the shield bar and
- disconnect voltage supplying sensors and pre-actuators.

Failure to follow these instructions will result in death or serious injury.

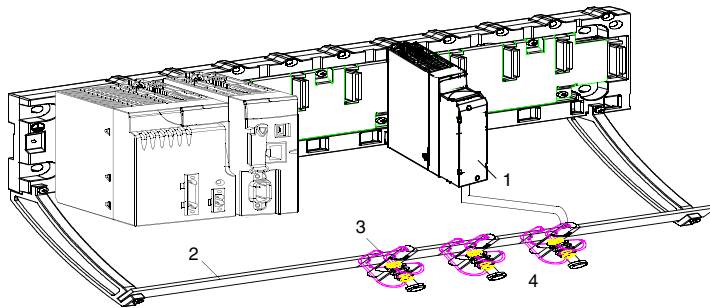

- 1 BMX AMI 0810
- 2 Shield bar
- 3 Clamp
- 4 To sensors

Reference of Sensors in Relation to the Ground

In order for the acquisition system to operate correctly, it is recommended to take in account the following precautions:

- sensors must be close together (a few meters)
- all sensors must be referenced to a single point, which is connected to the PLC's ground

Using the Sensors Referenced in Relation to the Ground

The sensors are connected as indicated in the following diagram:

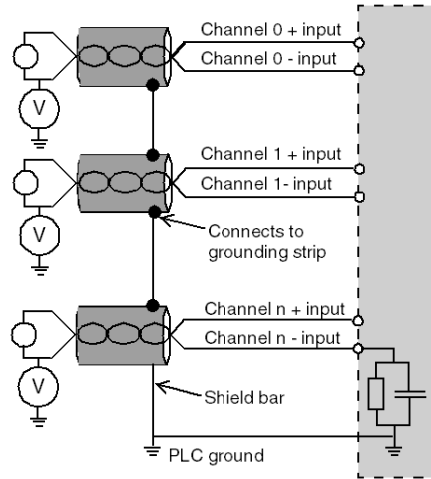

If the sensors are referenced in relation to the ground, this may in some cases return a remote ground potential to the terminal block. It is therefore **essential** to follow the following rules:

- The potential must be less than the permitted low voltage: for example, 30 Vrms or 42.4 VDC.
- Setting a sensor point to a reference potential generates a leakage current. You must therefore check that all leakage currents generated do not disturb the system.

NOTE: Sensors and other peripherals may be connected to a grounding point some distance from the module. Such remote ground references may carry considerable potential differences with respect to local ground. Induced currents do not affect the measurement or integrity of the system.

⚠ DANGER

HAZARD OF ELECTRIC SHOCK

Ensure that sensors and others peripherals are not exposed through grounding points to voltage potential greater than acceptable limits.

Failure to follow these instructions will result in death or serious injury.

Electromagnetic Hazard Instructions

CAUTION

UNEXPECTED BEHAVIOR OF APPLICATION

Follow those instructions to reduce electromagnetic perturbations:

- use the shielding connection kit BMXXSP•••• (*see page 50*) to connect the shielding.

Electromagnetic perturbations may lead to an unexpected behavior of the application.

Failure to follow these instructions can result in injury or equipment damage.

Wiring Diagram

Introduction

Module BMX AMI 0810 is connected using the 28-pin terminal block.

Illustration

The terminal block connection and the sensor wiring are as follows:

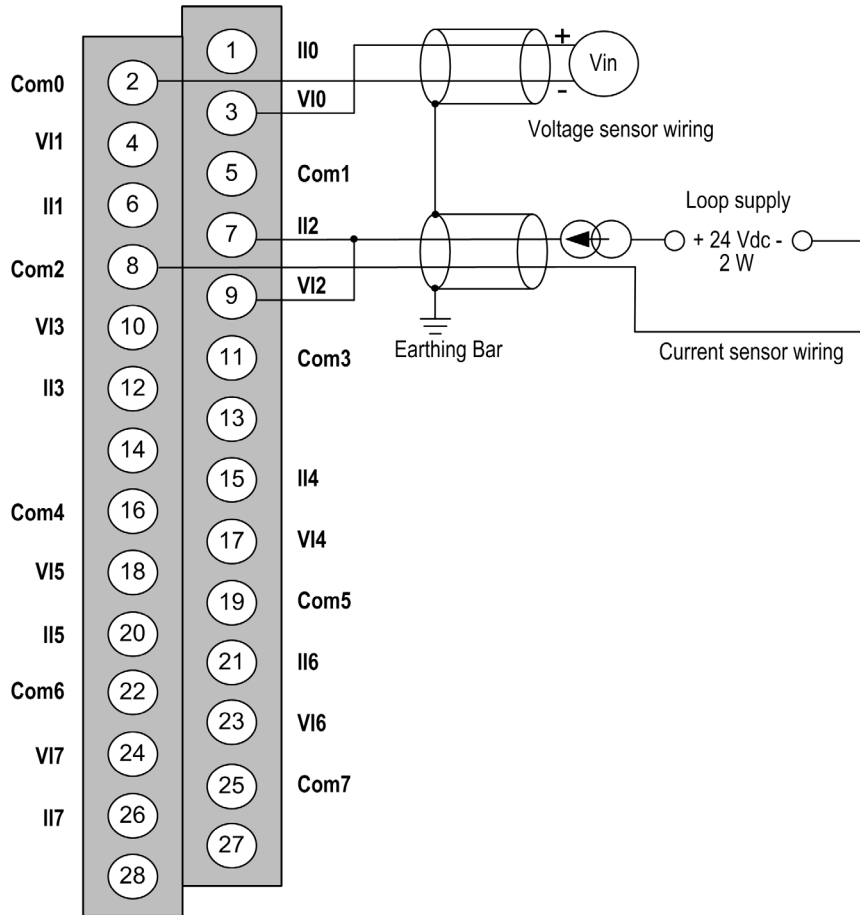

- V_{ix}** + pole input for channel x
- COM x** - pole input for channel x
- I_{ix}** current reading resistor + input
- Channel 0** voltage sensor
- Channel 1** 2-wire current sensor

Wiring Accessories

For rapid connection to operative parts, the module can be connected to a TELEFAST pre-wired system (*see page 119*).

Use of the TELEFAST ABE-7CPA02/31/31E Wiring Accessory

Introduction

The TELEFAST pre-wired system consists of connecting cables and interface sub-bases as shown below:

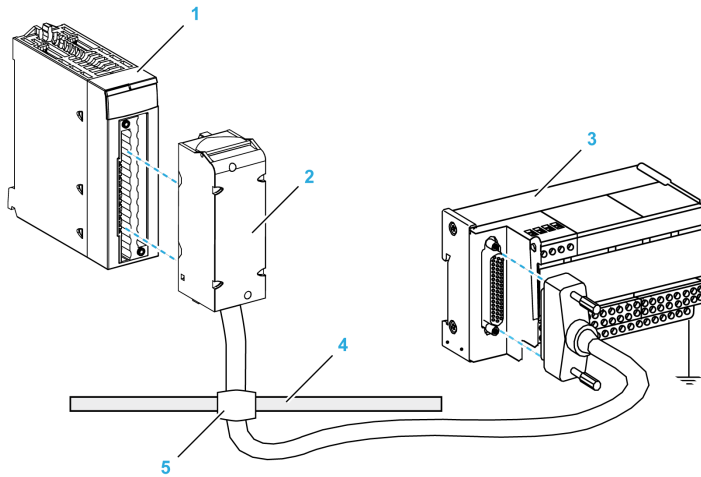

- 1 BMX AMI 0810
- 2 Connecting cable
- 3 Interface sub-base
- 4 Shield bar
- 5 Clamp

The BMX AMI 0810 module can be connected to the following references:

Connecting cables:

- BMXFTA150 (1.5 m (4.92 ft))
- BMXFTA300 (3 m (9.84 ft))

Interface sub-bases:

- ABE-7CPA02
- ABE-7CPA31
- ABE-7CPA31E

NOTE: In case HART information is part of the signal to be measured, an ABE-7CPA31E interface sub-base has to be used in order to filter this information that would disrupt the analog value.

ABE-7CPA02 Sensor Connection

The following table shows the distribution of analog channels on TELEFAST 2 terminal blocks with the reference ABE-7CPA02:

TELEFAST 2 terminal block number	25-pin Sub-D connector pin number	AMI08x0 pin out	Signal type	TELEFAST 2 terminal block number	25-pin Sub-D connector pin number	AMI08x0 pin out	Signal type
1	/		Ground	Supp 1	/		Ground
2	/		STD (1)	Supp 2	/		Ground
3	/		STD (1)	Supp 3	/		Ground
4	/		STD (2)	Supp 4	/		Ground
100	1	3	+IV0	200	14	2	COM0
101	2	1	+IC0	201	/		Ground
102	15	4	+IV1	202	3	5	COM1
103	16	6	+IC1	203	/		Ground
104	4	9	+IV2	204	17	8	COM2
105	5	7	+IC2	205	/		Ground
106	18	10	+IV3	206	6	11	COM3
107	19	12	+IC3	207	/		Ground
108	7	17	+IV4	208	20	16	COM4
109	8	15	+IC4	209	/		Ground
110	21	18	+IV5	210	9	19	COM5
111	22	20	+IC5	211	/		Ground
112	10	23	+IV6	212	23	22	COM6
113	11	21	+IC6	213	/		Ground
114	24	24	+IV7	214	12	25	COM7
115	25	26	+IC7	215	/		Ground

NOTE: On the ABE-7CPA02, the strap position is between pin 1 and pin 2.

+IVx: + pole voltage input for channel x.

+ICx: + pole current input for channel x.

COMx: - pole voltage or current input for channel x.

NOTE: For current sensors connected on the TELEFAST 2 ABE-7CPA02, a strap must be made on the BMX AMI 0800 terminal block between the current input and the voltage input as illustrated below.

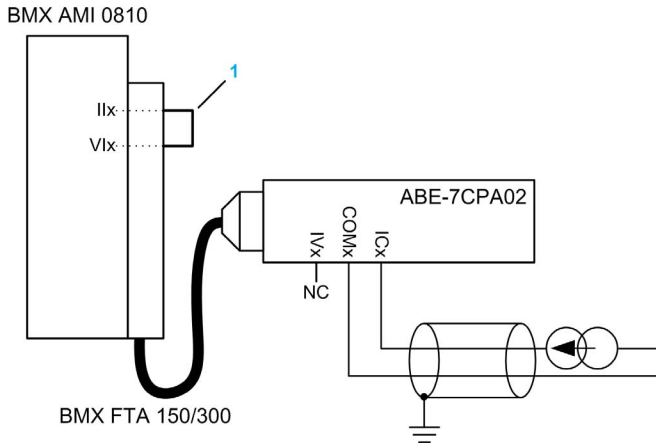

- 1 Strap on the terminal block.

NOTE: For the ground connection use the additional terminal block ABE-7BV10/20.

ABE-7CPA31 Sensor Connection

The following table shows the distribution of analog channels on TELEFAST 2 terminal blocks with the reference ABE-7CPA31:

TELEFAST 2 terminal block number	25-pin Sub-D connector pin number	AMI0810 pin out	Signal type	TELEFAST 2 terminal block number	25-pin Sub-D connector pin number	AMI0810 pin out	Signal type
1	/		Ground	Supp 1	/		24 V (sensor supply)
2	/		Ground	Supp 2	/		24 V (sensor supply)
3	/		Ground	Supp 3	/		0 V (sensor supply)
4	/		Ground	Supp 4	/		0 V (sensor supply)

+ISx: 24 V channel power supply
+IVx: + pole voltage input for channel x
+ICx: + pole current input for channel x
COMx: - pole voltage or current input for channel x.

TELEFAST 2 terminal block number	25-pin Sub-D connector pin number	AMI0810 pin out	Signal type	TELEFAST 2 terminal block number	25-pin Sub-D connector pin number	AMI0810 pin out	Signal type
100	/		+IS0	116	/		+IS4
101	1	3	+IV0	117	7	17	+IV4
102	2	1	+IC0	118	8	15	+IC4
103	14	2	0 V	119	20	16	0 V
104	/		+IS1	120	/		+IS5
105	15	4	+IV1	121	21	18	+IV5
106	16	6	+IC1	122	22	20	+IC5
107	3	5	0 V	123	9	19	0 V
108	/		+IS2	124	/		+IS6
109	4	9	+IV2	125	10	23	+IV6
110	5	7	+IC2	126	11	21	+IC6
111	17	8	0 V	127	23	22	0 V
112	/		+IS3	128	/		+IS7
113	18	10	+IV3	129	24	24	+IV7
114	19	12	+IC3	130	25	26	+IC7
115	6	11	0 V	131	12	25	0 V
<p>+ISx: 24 V channel power supply +IVx: + pole voltage input for channel x +ICx: + pole current input for channel x COMx: - pole voltage or current input for channel x.</p>							

NOTE: For the ground connection use the additional terminal block ABE-7BV10/20.

ABE-7CPA31E Sensor Connection

The following table shows the distribution of analog channels on TELEFAST 2 terminal blocks with the reference ABE-7CPA31E:

TELEFAST 2 terminal block number	Terminal	Signal type	TELEFAST 2 terminal block number	Terminal	Signal type
1	/	Ground	Supp 1	/	24 V (sensor supply)
2	/	Ground	Supp 2	/	24 V (sensor supply)
3	/	Ground	Supp 3	/	0 V (sensor supply)
4	/	Ground	Supp 4	/	0 V (sensor supply)
100	/	+IS0	116	/	+IS4
101	/	T0	117	/	T4
102	/	+IC0	118	/	+IC4
103	/	0V0	119	/	0V4
104	/	+IS1	120	/	+IS5
105	/	T1	121	/	T5
106	/	+IC1	122	/	+IC5
107	/	0V1	123	/	0V5
108	/	+IS2	124	/	+IS6
109	/	T2	125	/	T6
110	/	+IC2	126	/	+IC6
111	/	0V2	127	/	0V6
112	/	+IS3	128	/	+IS7
113	/	T3	129	/	T7
114	/	+IC3	130	/	+IC7
115	/	0V3	131	/	0V7
<p>+ISx: 24 V channel power supply Tx: Reserved test pin for HART function, it's internally connected with +ICx. +ICx: + pole current input for channel x COMx: - pole voltage or current input for channel x</p>					

NOTE: For the ground connection use the additional terminal block ABE-7BV10/20.

Chapter 6

BMX ART 0414/0814 Analog Input Modules

Subject of this Chapter

This chapter presents the BMX ART 0414/0814 modules, their characteristics and explains how they are connected to the various sensors.

What Is in This Chapter?

This chapter contains the following topics:

Topic	Page
Presentation	126
Characteristics	127
Analog Input Values	131
Functional Description	134
Wiring Precautions	139
Wiring Diagram	143
Use of the TELEFAST ABE-7CPA412 Accessory	146

Presentation

Function

The BMX ART 0414/0814 modules are multi-range acquisition devices with four inputs for the 0414 and eight inputs for the 0814. The inputs are isolated from each other. These modules offer the following ranges for each input, according to the selection made at configuration:

- RTD IEC Pt100/Pt1000, US/JIS Pt100/Pt1000, Cu10, Cu50, Cu100, Ni100/Ni1000 in 2, 3 or 4 wires
- thermocouple B, E, J, K, L, N, R, S, T, U
- voltage +/- 40 mV to 1.28 V.

Illustration

The BMX ART 0414/0814 analog input modules looks like this:

BMX ART 0414

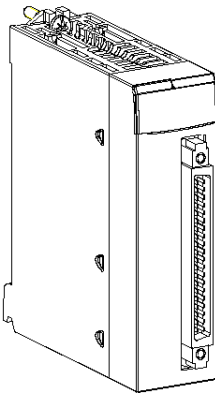

BMX ART 0814

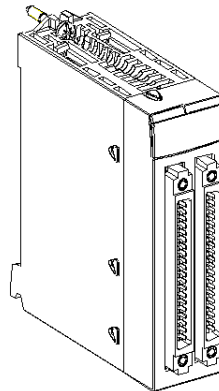

Characteristics

General Characteristics

The general characteristics for the BMX ART 0414/BMX ART 0414H and BMX ART 0814/BMX ART 0814H modules are as follows:

Modules	ART 0414	ART 0814	
Type of inputs	Isolated, RTD, thermocouple and voltage inputs		
Nature of inputs	+/- 40 mV; +/- 80 mV; +/- 160 mV; +/- 320 mV; +/- 640 mV; 1.28 V		
Number of channels	4	8	
Acquisition cycle time	400 ms / 4 channels	400 ms / 8 channels	
Conversion method	$\Sigma\Delta$		
Resolution	15-bit + sign		
Isolation: <ul style="list-style-type: none"> ● Between channels ● Between channels and bus ● Between channels and ground 	<ul style="list-style-type: none"> ● 750 Vdc ● 1400 Vdc ● 750 Vdc 		
Maximum authorized over voltage for inputs	+/- 7.5 Vdc		
Cold junction compensation	<ul style="list-style-type: none"> ● Internal compensation using the dedicated TELEFAST ABE-7CPA412 wiring accessory, including a sensor. ● External compensation dedicating channel 0 to a 2/3-wires Pt100 for CJC. ● External compensation using the CJC values of channels 4/7 for channels 0/3. In this case, only one sensor is needed. 		
Input filter	Low pass filter (1st order numerical)		
Rejection in differential mode (50/60 Hz)	Typical 60 dB		
Common mode rejection (50/60 Hz)	Typical 120 dB		
Power consumption (3.3 V)	Typical	0.32 W	0.32 W
	Maximum	0.48 W	0.48 W
Power consumption (24 V)	Typical	0.47 W	1.00 W
	Maximum	1.20 W	1.65 W

Voltage Input Characteristics

The characteristics of the voltage inputs of the BMX ART 0414/BMX ART 0414H and BMX ART 0814/BMX ART 0814H modules are as follows:

Voltage range:	+/- 40 mV; +/- 80 mV; +/- 160 mV; +/- 320 mV; +/- 640 mV; 1.28 V
Input impedance:	Typical 10 MOhms
Maximum converted value:	+/- 102.4%
Maximum resolution:	2.4 µV in the range +/- 40 mV
Measurement error for standard module:	
<ul style="list-style-type: none"> ● At 25°C (77°F) ● Maximum in the temperature range 0...60°C (32...140°F) 	0.05% of FS (1) 0.15% of FS (1)
Measurement error for Hardened module:	
<ul style="list-style-type: none"> ● At 25°C (77°F) ● Maximum in the temperature range -25°C..70°C (-13...140°F) 	0.05% of FS (1) 0.20% of FS (1)
Temperature drift:	
	30 ppm/°C
Legend:	
(1) FS: Full Scale	

RTD Input Characteristics

The characteristics of the RTD inputs of the BMX ART 0414/BMX ART 0414H and BMX ART 0814/BMX ART 0814H modules are as follows:

RTD	Pt100	Pt1000	Ni100	Ni1000	Cu10	CU50	CU100
Measurement range	According to IEC -175... +825°C (-347...+1517°F) According to US/JIS: -87 +437°C (-125...+819°F)		-54...+174°C (-65...+345°F)		-91...+251°C (-132...+484°F)	-200...+200°C (-328...+392)	
Resolution	0.1°C (0.2°F)						
Detection type	Open circuit (detection on each channel)						
Error at 25°C (77°F) (1)	+/- 2.1 °C (+/- 3.8°F)	+/- 2.1 °C (+/- 3.8°F)	+/- 0.7°C (+/- 1.3°F)	+/- 0.7°C (+/- 1.3°F)	+/- 4 °C (+/- 7.2°F)	+/- 2.1°C (+/- 3.8°F)	+/- 2.1°C (+/- 3.8°F)

RTD	Pt100	Pt1000	Ni100	Ni1000	Cu10	CU50	CU100
Maximum error for STANDARD modules in the temperature range 0...60°C (32...140°F) (2)	+/- 3 °C (+/- 5.4°F)		+/- 3 °C (+/- 5.4°F)	+/- 0.7°C (+/- 1.3°F)	+/- 4 °C (+/- 7.2°F)		+/- 3°C (+/- 5.4°F)
Maximum error for HARDENED modules in the temperature range 0...60°C (32...140°F)(2)	+/- 3 °C (+/- 5.4°F)		+/- 3.5°C (+/- 6.3°F)	+/- 1.15°C (+/- 2.1°F)	+/- 4.5°C (+/- 8.1°F)		+/- 3.5°C (+/- 6.3°F)
Maximum wiring resistance:							
● 4-wire	50 Ω	500 Ω	50 Ω	500 Ω	50 Ω		50 Ω
● 2/3-wire	20 Ω	200 Ω	20 Ω	200 Ω	20 Ω		20 Ω
Temperature drift:							
	30 ppm/°C						
Legend							
(1) errors caused by the wiring, +/- 1°C (0.2°F) in the range -100...+200°C (-148...+392°F) for Pt100							
(2) See detailed errors at temperature point (see page 354).							

Thermocouple Input Characteristics

This table presents the general characteristics of the thermocouple inputs of the BMX ART 0414/BMX ART 0414H and BMX ART 0814/BMX ART 0814H modules:

Thermocouples	B	E	J	K	L
Measurement range	+171... +1,779°C (340... 3234°F)	-240... +970°C (-400...1778°F)	-177...+737°C (-287... 1359°F)	-231... +1,331°C (-384... 2428°F)	-174... +874°C (-281... 1605°F)
Thermocouples	N	R	S	T	U
Measurement range	-232 +1,262°C (-386... 2304°F)	-9... +1,727°C (16... 3234°F)	-9... +1,727°C (-16... 141°F)	-254... +384°C (- 425... 723°F)	-181... +581°C (-294... 1078°F)
Resolution	0.1°C (0.2°F)				
Detection type	Open circuit (detection on each channel)				
Error at 25°C	+/- 3.2°C for J, L, R, S and U types (see Thermocouple Ranges (see page 356) for detailed errors at temperature point for each type); +/- 3.7°C for B, E, K, N and T types				

Thermocouples	B	E	J	K	L
Maximum error for STANDARD modules in the temperature range -25°C...70°C (-13...140°F) (2)	+/- 4.5°C (+/-8.1°F) for types: J, L, R, S and U; +/- 5°C (+/-9°F) for types: B, E, K, N and T (using the TELEFAST accessory with its internal cold junction compensation).				
Maximum error for HARDENED modules in the temperature range -25°C...70°C (-13...140°F) (2)	+/- 5.5°C (+/-9°F) for types: J, L, R, S and U; +/- 6°C (+/-10.8°F) for types: B, E, K, N and T (using the TELEFAST accessory with its internal cold junction compensation).				
Temperature drift	30 ppm/°C				

Resistive Input Characteristics

The characteristics of the resistive inputs of the BMX ART 0414/BMX ART 0414H and BMX ART 0814/BMX ART 0814H are as follows:

Range	400 Ω; 4000 Ω
Type measurement	2, 3, 4 wires
Maximum resolution	12.5 mΩ in the range 400 Ω 125 mΩ in the range 4000 Ω
Measurement error for standard module:	
<ul style="list-style-type: none"> At 25°C (77°F) Maximum in the temperature range 0...60°C (32...140°F) 	0.12% of FS (1) 0.2% of FS (1)
Measurement error for ruggedized module:	
<ul style="list-style-type: none"> At 25°C Maximum in the temperature range -25°C...70°C (-13...140°F) 	0.12% of FS (1) 0.3% of FS (1)
Temperature drift	25 ppm/°C
Legend:	
(1) FS: Full Scale	

Analog Input Values

Description

For RTD and TC sensors, the data is a multiple of 10 of the real temperature in °C or °F. The last digit represents 0.1°C or 0.1°F.

For millivoltmeter, the data ranges from 40 mV, 320 mV to 1280 mV and is also a multiple of 10 of the real measurement. The last digit represents 10 nV.

For millivoltmeter, the data range of 640 mV is a multiple of 100 of the real measurement. The last digit represents 100 nV.

RTD Ranges

The table below presents the ranges for the RTD sensors (values in brackets are in 1/10°F).

Range	Under flow	Lower scale	Upper scale	Over flow
Pt100 IEC 751-1995, JIS C1604-1997 (2/4 wires)	-1990 (-3260)	-1750 (-2830)	8250 (15170)	8490 (15600)
Pt1000 IEC 751-1995, JIS C1604-1997 (2/4 wires)	-1990 (-3260)	-1750 (-2830)	8250 (15170)	8490 (15600)
Ni100 DIN43760-1987 (2/4 wires)	-590 (-750)	-540 (-660)	1740 (3460)	1790 (3550)
Ni1000 DIN43760-1987 (2/4 wires)	-590 (-750)	-540 (-660)	1740 (3460)	1790 (3550)
Pt100 IEC 751-1995, JIS C1604-1997 (3 wires)	-1990 (-3260)	-1750 (-2830)	8250 (15170)	8490 (15600)
Pt1000 IEC 751-1995, JIS C1604-1997 (3 wires)	-1990 (-3260)	-1750 (-2830)	8250 (15170)	8490 (15600)
Ni100 DIN43760-1987 (3 wires)	-590 (-750)	-540 (-660)	1740 (3460)	1790 (3550)
Ni1000 DIN43760-1987 (3 wires)	-590 (-750)	-540 (-660)	1740 (3460)	1790 (3550)
JPt100 JIS C1604-1981, JIS C1606-1989 (2/4 wires)	-990 (-1460)	-870 (-1240)	4370 (8180)	4490 (8400)
JPt1000 JIS C1604-1981, JIS C1606-1989 (2/4 wires)	-990 (-1460)	-870 (-1240)	4370 (8180)	4490 (8400)
JPt100 JIS C1604-1981, JIS C1606-1989 (3 wires)	-990 (-1460)	-870 (-1240)	4370 (8180)	4490 (8400)
JPt1000 JIS C1604-1981, JIS C1606-1989 (3 wires)	-990 (-1460)	-870 (-1240)	4370 (8180)	4490 (8400)

Range	Under flow	Lower scale	Upper scale	Over flow
Cu10 (2/4 wires)	-990 (-1460)	-910 (-1320)	2510 (4840)	2590 (4980)
Cu10 (3 wires)	-990 (-1460)	-910 (-1320)	2510 (4840)	2590 (4980)

TC Ranges

The table below presents the ranges for the TC sensors (values in brackets are in (1/10°F)).

Range	Under flow	Lower scale	Upper scale	Over flow
Type J	-1980 (-3260)	-1770 (-2870)	7370 (13590)	7580 (13980)
Type K	-2680 (-4500)	-2310 (-3830)	13310 (24270)	13680 (24940)
Type E	-2690 (-4510)	-2400 (-3990)	9700 (17770)	9990 (18290)
Type T	-2690 (-4520)	-2540 (-4250)	3840 (7230)	3990 (7500)
Type S	-500 (-540)	-90 (160)	17270 (29550)	17680 (30250)
Type R	-500 (-540)	-90 (160)	17270 (29550)	17680 (30250)
Type B	1320 (2700)	1710 (3390)	17790 (32000)	18170 (32000)
Type N	-2670 (-4500)	-2320 (-3860)	12620 (23040)	12970 (23680)
Type U	-1990 (-3250)	-1810 (-2930)	5810 (10770)	5990 (11090)
Type L	-1990 (-3250)	-1740 (-2800)	8740 (16040)	8990 (16490)

Voltage Ranges

The table below presents the voltage ranges default values.

Range	Under flow	Lower scale	Upper scale	Over flow
+/- 40 mV	-4192	-4000	4000	4192
+/- 80 mV	-8384	-8000	8000	8384
+/- 160 mV	-16768	-16000	16000	16768
+/- 320 mV	-32000	-32000	32000	32000
+/- 640 mV	-6707	-6400	6400	6707
+/- 1280 mV	-13414	-12800	12800	13414

Resistance Ranges

The table below presents the resistance ranges default values.

Range	Under flow	Lower scale	Upper scale	Over flow
0-400 Ohms 2/4 wires	0	0	4000	4096
0-4000 Ohms 2/4 wires	0	0	4000	4096
0-400 Ohms 3 wires	0	0	4000	4096
0-4000 Ohms 3 wires	0	0	4000	4096

Functional Description

Function

The BMX ART 0414/814 modules are multi-range acquisition devices with four inputs for the BMX ART 0414 and eight inputs for the BMX ART 0814.

Both Modules offer the following ranges for each input, according to the selection made during configuration:

- RTD: IEC Pt100, IEC Pt1000, US/JIS Pt100, US/JIS Pt1000, Copper CU10, Ni100 or Ni1000
- thermocouple: B, E, J, K, L, N, R, S, T or U,
- voltage: +/- 80 mV, +/- 80 mV, +/- 160 mV, +/- 320 mV, +/- 640 mV, +/- 1.28 V,
- ohms: 0..400 Ω, 0..4000 Ω.

NOTE: The TELEFAST2 accessory referenced **ABE-7CPA412** facilitates connection and provides a cold junction compensation device.

Illustration

The BMX ART 0414/0814 input modules perform the following functions.

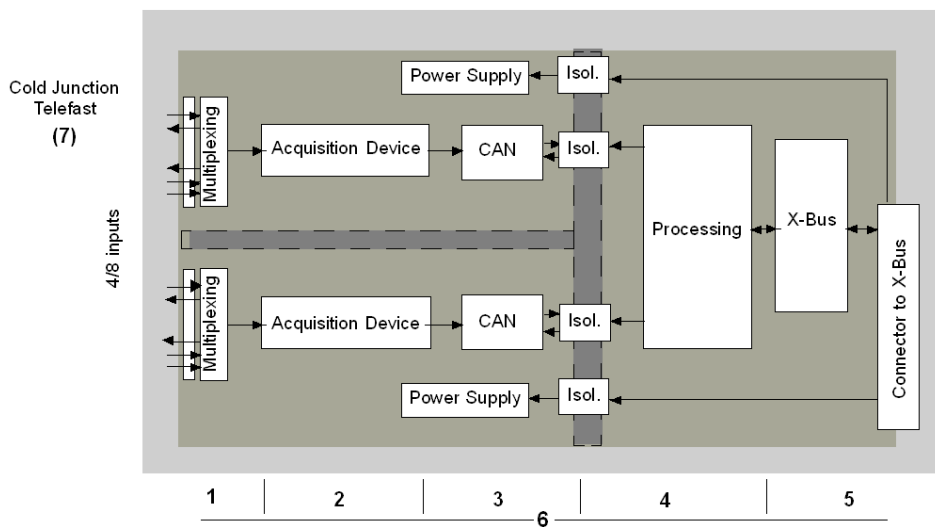

Details of the functions are as follows.

Address	Element	Function
1	Adapting the Inputs	Adaptation consists in a common mode and differential mode filter. Protection resistors on the inputs allow to withstand voltage spikes of up to +/- 7.5 V. A layer of multiplexing allows self-calibration of the acquisition device offset, as close as possible to the input terminal, as well as selecting the cold junction compensation sensor included in the TELEFAST housing.
2	Amplifying Input Signals	Built around a weak-offset amplifier internal to the A/N converter. A current generator ensures the RTD resistance measurement.
3	Conversion	The converter receives the signal issued from an input channel or from the cold junction compensation. Conversion is based on a $\Sigma \Delta$ 16-bit converter. There is a converter for each input.
4	Transforming incoming values into workable measurements for the user	<ul style="list-style-type: none"> recalibration and alignment coefficients to be applied to measurements, as well as the module's self-calibration coefficients (numeric) filtering of measurements, based on configuration parameters scaling of measurements, based on configuration parameters
5	Communicating with the Application	<ul style="list-style-type: none"> manages exchanges with CPU. topological addressing receiving configuration parameters from module and channels sending measured values, as well as module status, to the application
6	Module monitoring and sending error notification back to application	<ul style="list-style-type: none"> conversion string test range under/overflow on channels and cold junction compensation process test watchdog test
7	Cold Junction Compensation	<ul style="list-style-type: none"> internal compensation using the TELEFAST ABE-7CPA412 external compensation by Pt100 external compensation using the CJC values of channels 4/7 for channels 0/3. In this case, only one sensor is needed

Display of Electrical Range Measurements

Measurements may be displayed using standardized display (in %, to two decimal places).

Type of Range	Display
Bipolar range	from -10,000 to +10,000 (-100.00 % to +100.00 %)

It is also possible to define the range of values within which measurements are expressed, by selecting:

- the lower threshold corresponding to the minimum value for the range -100.00 %
- the upper threshold corresponding to the maximum value for the range +100.00 %

These lower and upper thresholds are integers between -32,768 and 32,768.

Display of Temperature Range Measurements

Measurements provided to the application are directly usable. It is possible to choose either "In Temperature" Display or Standardized Display:

- for "In Temperature" display mode, values are provided in tenths of a degree (Celsius or Fahrenheit, depending on the unit you have selected).
- for the user-specified display, you may choose a Standardized Display 0...10,000 (meaning from 0 to 100.00 %), by specifying the minimum and maximum temperatures as expressed in the 0 to 10,000 range.

Measurement Filtering

The type of filtering performed by the system is called "first order filtering". The filtering coefficient can be modified from a programming console or via the program.

The mathematical formula used is as follows:

$$Mesf(n) = \alpha \times Mesf(n - 1) + (1 - \alpha) \times Valb(n)$$

where:

α = efficiency of the filter

Mesf(n) = measurement filtered at moment n

Mesf(n-1) = measurement filtered at moment n-1

Valg(n) = gross value at moment n

You may configure the filtering value from 7 possibilities (from 0 to 6). **This value may be changed even when the application is in RUN mode.**

NOTE: Filtering may be accessed in Normal or Fast Cycle.

The filtering values are as follows. They depend on the sensor type. T is a cycle time of 200 ms for TC and mV. T is also a cycle time of 400 ms for RTD and Ohms.

Desired Efficiency	Required Value	Corresponding α	Filter Response Time at 63%	Cut-off Frequency (in Hz)
No filtering	0	0	0	0
Low filtering	1	0.750	4 x T	0.040 / T
	2	0.875	8 x T	0.020 / T
Medium filtering	3	0.937	16 x T	0.010 / T
	4	0.969	32 x T	0.005 / T
High filtering	5	0.984	64 x T	0.025 / T
	6	0.992	128 x T	0.012 / T

The values may be displayed using standardized display (in %, to two decimal places).

Type of Range	Display
Unipolar range	from 0 to 10,000 (0 % at +100.00 %)
Bipolar range	from -10,000 to 10,000 (-100.00 % to +100.00 %)

The user may also define the range of values within which measurements are expressed, by selecting:

- the lower threshold corresponding to the minimum value for the range -100.00 %
- the upper threshold corresponding to the maximum value for the range +100.00 %.

These lower and upper thresholds are integers between -32,768 and +32,767.

Main frequency 50/60 Hz Rejection

Depending on the country, the user can configure the frequency rejection of main power harmonics by adapting the speed of sigma delta converter.

Sensor Alignment

The process of "alignment" consists in eliminating a systematic offset observed with a given sensor, around a specific operating point. This operation compensates for an error linked to the process. Therefore, replacing a module does not require a new alignment. However, replacing the sensor or changing the sensor's operating point does require a new alignment.

Conversion lines are as follows:

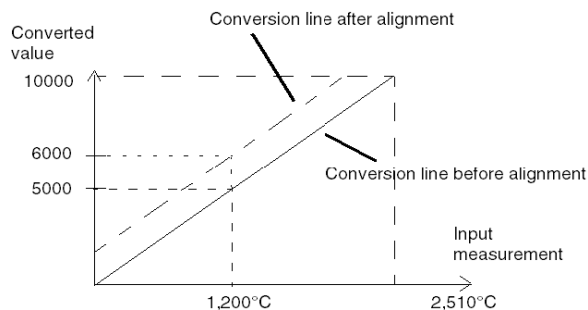

The alignment value is editable from a programming console, even if the program is in RUN Mode. For each input channel, you can:

- view and modify the desired measurement value.
- save the alignment value.
- determine whether the channel already has an alignment.

The alignment offset may also be modified through programming.

Channel alignment is performed on the channel in standard operating mode, without any effect on the channel's operating modes.

The maximum offset between measured value and desired (aligned) value may not exceed +/- 1,500.

NOTE: To align several analog channels on the BMX ART/AMO/AMI/AMM modules, we recommend proceeding channel by channel. Test each channel after alignment before moving to the next channel in order to apply the parameters correctly.

Wiring Precautions

Introduction

In order to protect the signal from outside interference induced in series mode and interference in common mode, we recommend that you take the following precautions.

Cable Shielding

- Connection at the FCN connectors:
Given that there are a large number of channels, a cable of at least 10 twisted pairs is used, with general shielding (outside diameter 10 mm maximum), fitted with one or two male 40-pin FCN connectors for direct connection to the module.
Connect the cable shielding to the grounding bar. Clamp the shielding to the grounding bar on the module side. Use the shielding connection kit BMXXSP•••• (see page 50) to connect the shielding.

⚠ DANGER

HAZARD OF ELECTRIC SHOCK, EXPLOSION, OR ARC FLASH

While mounting / removing the modules:

- make sure that each terminal block is still connected to the shield bar and
- disconnect voltage supplying sensors and pre-actuators.

Failure to follow these instructions will result in death or serious injury.

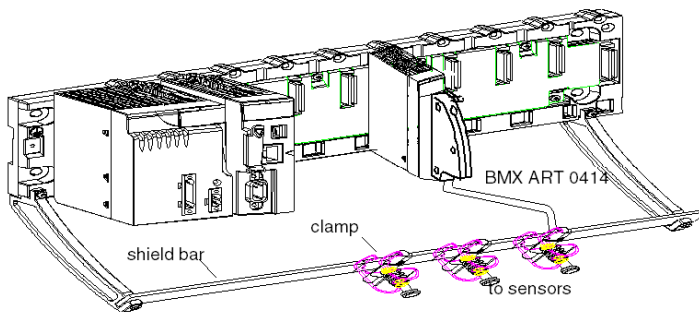

- **TELEFAST connection:**
Connect the sensor cable shielding to the terminals provided and the whole assembly to the cabinet ground.

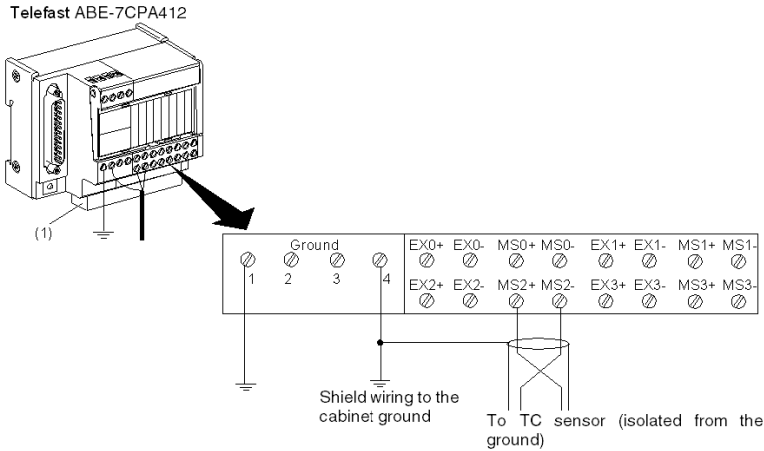

(1) The grounding of cables is facilitated using the ABE-7BV10 accessory.

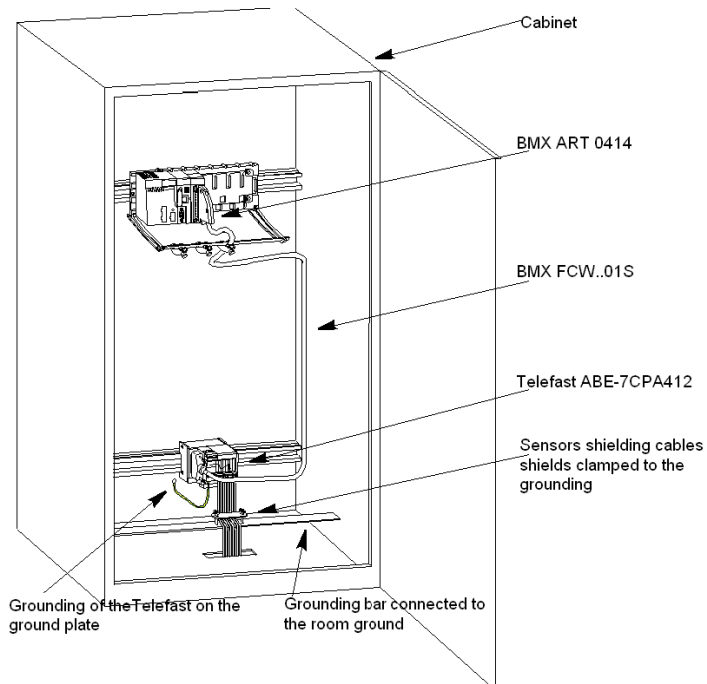

Sensors shielding

In order for the acquisition system to operate correctly, we recommend you take the following precautions:

- if sensors are isolated from ground, all the shields of the sensor cables must be referenced to the Telefast/PLC ground.

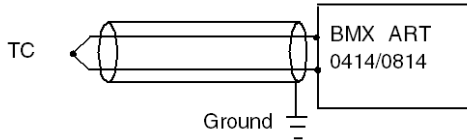

- if sensors are referenced to the sensor ground which is far from PLC ground, all the shields of the sensor cables must be referenced to the sensors ground to eliminate the ground loop path.

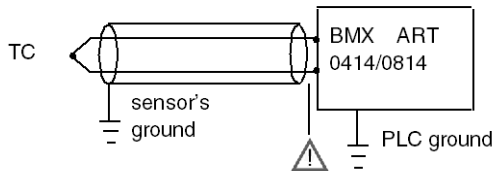

Using the Sensors Isolated from the Ground

The sensors are connected according to the following diagram:

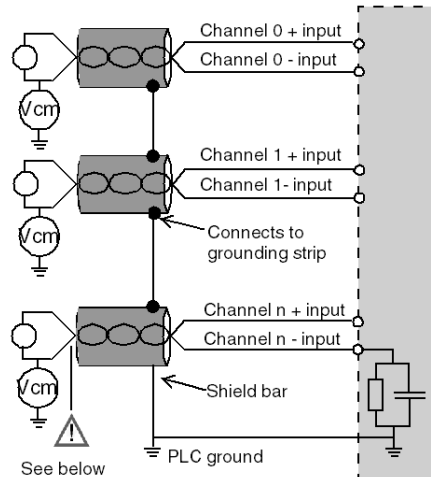

If the sensors are referenced in relation to the ground, this may in some cases return a remote ground potential to the terminals or the FCN connector. It is therefore essential to follow the following rules:

- the potential must be less than the permitted low voltage: for example, 30 Vrms or 42.4 VDC.
- setting a sensor point to a reference potential generates a leakage current. You must therefore check that all leakage currents generated do not disturb the system.

Sensors and other peripherals may be connected to a grounding point some distance from the module. Such remote ground references may carry considerable potential differences with respect to local ground. Induced currents do not affect the measurement or integrity of the system.

DANGER

HAZARD OF ELECTRIC SHOCK

Ensure that sensors and others peripherals are not exposed through grounding points to voltage potential greater than acceptable limits.

Failure to follow these instructions will result in death or serious injury.

Electromagnetic Hazard Instructions

CAUTION

UNEXPECTED BEHAVIOR OF APPLICATION

Follow those instructions to reduce electromagnetic perturbations:

- use the shielding connection kit BMXXSP**** (*see page 50*) to connect the shielding.

Electromagnetic perturbations may lead to an unexpected behavior of the application.

Failure to follow these instructions can result in injury or equipment damage.

Wiring Diagram

Introduction

The BMX ART 0414 input module consists of a 40-pin FCN connector.

The BMX ART 0814 input module consists of two 40-pin FCN connectors.

WARNING

UNEXPECTED EQUIPMENT OPERATION

Take every precaution at the installation to prevent any subsequent mistake in the connectors. Plugging the wrong connector would cause an unexpected behavior of the application.

Failure to follow these instructions can result in death, serious injury, or equipment damage.

Connector Pin Assignment and Sensors Wiring

This example uses a probe configuration with:

- Channel 0/4: Thermocouple
- Channel 1/5: 2-wires RTD
- Channel 2/6: 3-wires RTD
- Channel 3/7: 4-wires RTD

The pin assignment for the 40-pin FCN connector and the sensors wiring is shown below:

Module Front View - cabling view

Left connector

Right connector (BMX ART 414 only)

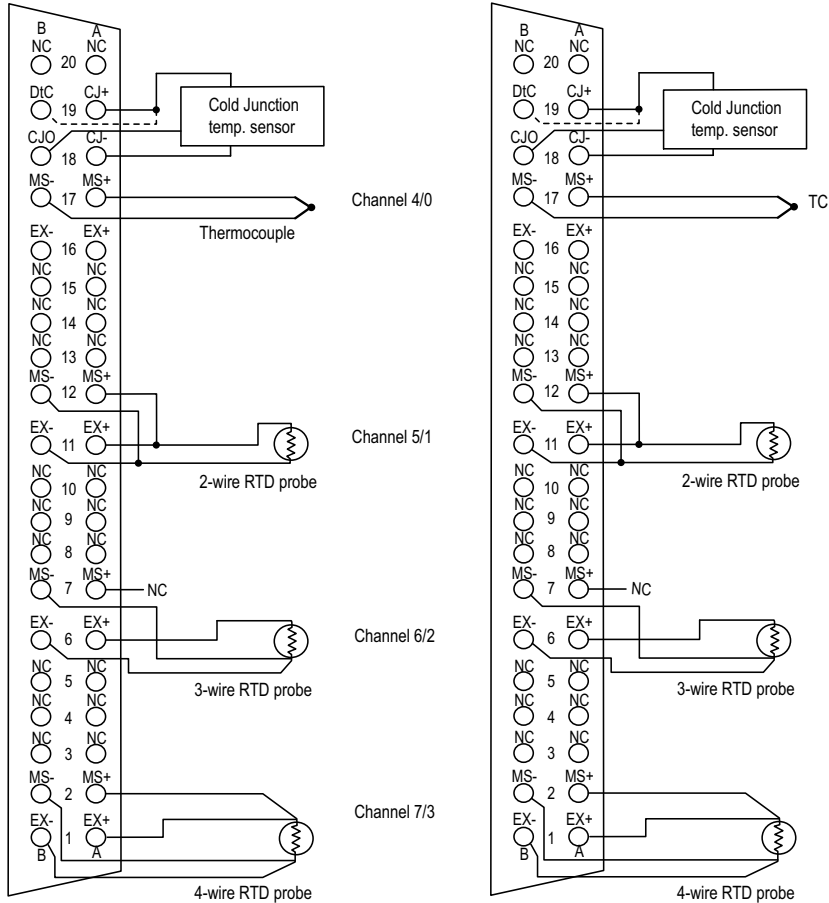

MS+: RTD Measure + input / Thermocouple + input

MS-: RTD Measure - input / Thermocouple - input

EX+: RTD probe current generator + output

EX-: RTD probe current generator - output

NC: Not connected

DiC: The CJC sensor detection input is connected to CJ+ if the sensor type is DS600. It is not connected (NC) if the sensor type is LM31.

NOTE: The CJC sensor is needed for TC only.

Cold Junction Compensation

For each block of 4 channels (channels 0 to 3 and channels 4 to 7), the external compensation of the module is performed in the TELEFAST ABE-7CPA412 accessory. This device provides a voltage in mV corresponding to:

$$\text{Voltage} = (6.45 \text{ mV} * T) + 509 \text{ mV} \text{ (where } T = \text{temperature in } ^\circ\text{C)}.$$

The overall margin of error when using this device is reduced to 1.2°C in the -5°C to +60°C temperature range.

It is possible to increase the precision of the compensation by using a 2/3-wires Pt100 probe directly connected to channels 0 and 4 (only for the BMX ART0814) on the module or connected to the TELEFAST terminal blocks. Channel 0 is thus dedicated to the cold junction compensation of channels 1, 2 and 3. channel 4 is thus dedicated to channels 4 to 7.

It is also possible, by using a 2-wire Pt100 probe, provided the initial length of the probe is limited, to maintain channel 0 as a thermocouple input.

The wiring would then look like this:

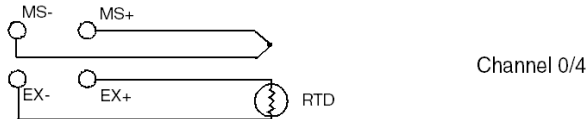

The wiring is only valid if the channel 0 is used. If the channel 0 is not used, select a cold junction with external Pt100. The range of the channel 0 is changed to a 3-wires Pt100 probe.

The wiring would then look like this:

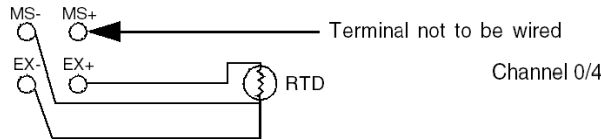

NOTE: For the BMX ART 0814 Module, the CJC values of channels 4 to 7 can also be used for channels 0 to 3. Therefore, only one external CJC ([see page 147](#)) sensor is wired on channel 4.

Use of the TELEFAST ABE-7CPA412 Accessory

At a Glance

The TELEFAST ABE-7CPA412 accessory is a base unit used to connect 4-channel analog modules to screw terminal blocks.

NOTE: When the cabinet where the TELEFAST ABE-7CPA412 accessory is located and powered up, wait at least 45mn to achieve full precision of the CJC compensation. It is not necessary to wait 45 mn if the compensation is performed by an external Pt100 probe.

When using the TELEFAST ABE-7CPA412's cold junction compensation, in order to make sure you achieve the indicated level of precision, the movement of air around the TELEFAST ABE-7CPA412 must not exceed 0.1 m/s. Temperature variations must not exceed 10°C/hour and the TELEFAST ABE-7CPA412 must be placed at least 100mm away from all heat sources.

The TELEFAST ABE-7CPA412 can be operated from -40°C to +80°C external temperature.

Connecting Sensors

Sensors may be connected to the TELEFAST ABE-7CPA412 accessory as shown in this illustration (see page 139).

Wirings

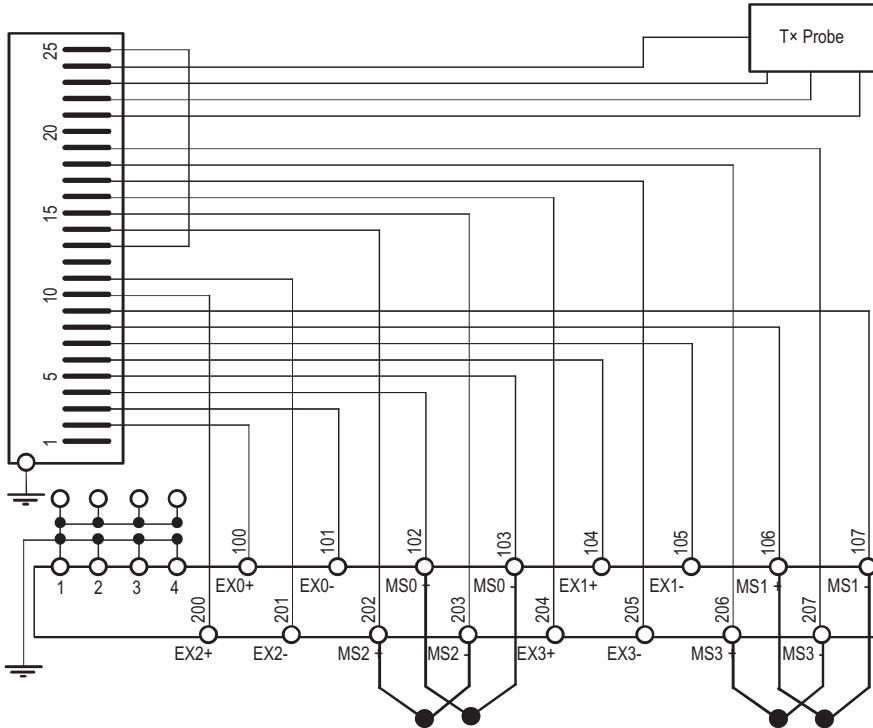

Legend: Operating in TC mode with Telefast internal cold junction compensation.

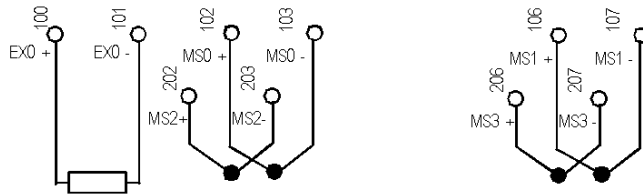

Legend: Operating in TC mode with cold junction compensation using a 2-wire PT100 probe.

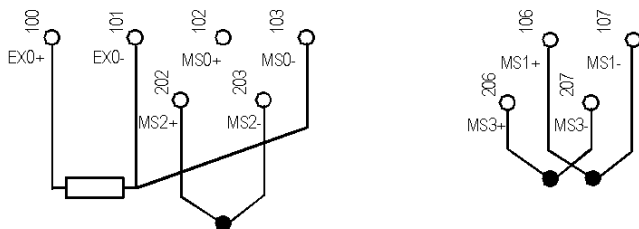

Legend: Operating in TC mode with cold junction compensation using a 3-wire PT100 probe.

Connecting Modules

Modules can be connected to a TELEFAST ABE-7CPA412 as shown in the illustration below:

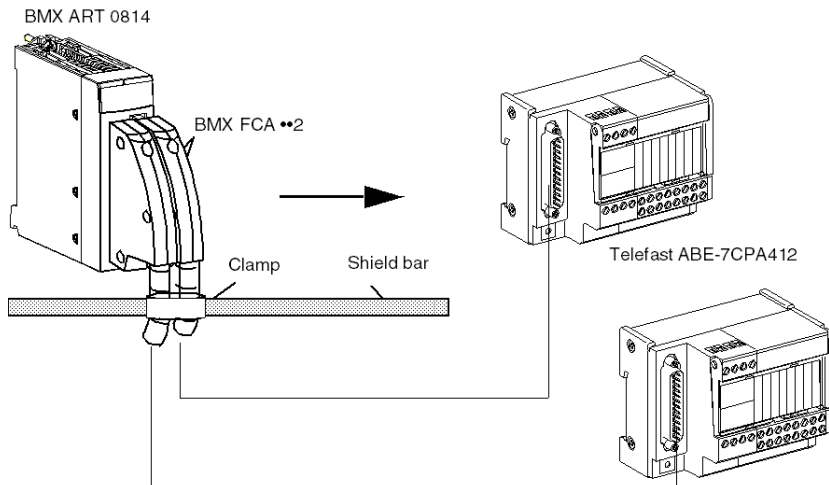

The BMX ART 0414/0814 analog modules may be connected to the TELEFAST ABE-7CPA412 accessory using one of the following cables:

- BMX FCA 152: length 1.5 m
- BMX FCA 302: length 3 m
- BMX FCA 502: length 5 m

Chapter 7

BMX AMO 0210 Analog Output Module

Subject of this Chapter

This chapter presents the BMX AMO 0210 module, its characteristics, and explains how it is connected to the various pre-actuators and actuators.

What Is in This Chapter?

This chapter contains the following topics:

Topic	Page
Presentation	150
Characteristics	151
Functional Description	154
Wiring Precautions	159
Wiring Diagram	161
Use of the TELEFAST ABE-7CPA21 Wiring Accessory	162

Presentation

Function

The BMX AMO 0210 is a module with two analog outputs isolated from one other. It offers the following ranges for each output:

- Voltage +/-10 V
- Current 0..20 mA and 4..20 mA

The range is selected during configuration.

Illustration

The BMX AMO 0210 analog output module looks like this.

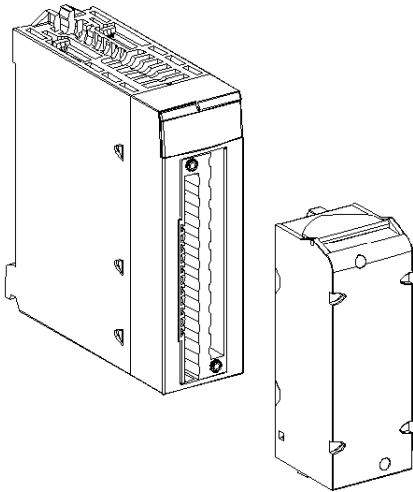

NOTE: The terminal block is supplied separately.

Characteristics

General Characteristics

The general characteristics for the BMX AMO 0210 and BMX AMO 0210H modules are as follows.

Type of outputs	Isolated high level outputs	
Nature of outputs	Voltage or Current configured by software	
Number of channels	2	
Analog/Digital converter resolution	15 bits + sign	
Output refresh time	≤ 1 ms	
Power supply for outputs	by the module	
Types of protection	From short circuits and overloads (Voltage output)	
Isolation:		
● Between channels	750 VDC	
● Between channels and bus	1400 VDC	
● Between channels and ground	1400 VDC	
Measurement error for standard module:		
● At 25°C (77°F)	0.10% of FS (1)	
● Maximum in the temperature range 0..60°C (32..140°F)	0.20% of FS (1)	
Measurement error for ruggedized:		
● At 25°C (77°F)	0.10% of FS (1)	
● Maximum in the temperature range -25..70°C (-13..158°F)	0.45% of FS (1)	
Temperature drift	30 ppm/°C	
Monotonicity	Yes	
Non linearity	0.1% of FS	
AC output ripple	2 mV rms on 50 Ω	
Power consumption (3.3 V)	Typical	0.35 W
	Maximum	0.48 W
Power consumption (24 V)	Typical	2.3 W
	Maximum	2.8 W
Legend		
(1) FS: Full Scale		

Voltage Output

The BMX AMO 0210 and BMX AMO 0210H voltage outputs have the following characteristics.

Nominal variation range	+/-10 V
Maximum variation range	+/- 11.25 V
Analog resolution	0.37 mV
Load impedance	1 KΩ minimum
Detection type	Short circuits

Current Output

The BMX AMO 0210 and BMX AMO 0210H current outputs have the following characteristics.

Nominal variation range	0..20 mA, 4..20 mA
Available maximum current	24 mA
Analog resolution	0.74 μA
Load impedance	600 Ω maximum
Detection type	Open circuit (1)
Legend	
(1) The open circuit detection is physically detected by the module if the target current value is different of 0 mA.	

Response time of Outputs

The maximum delay between transmission of the output value on the PLC bus and its effective positioning on the terminal block is less than 2 ms:

- internal cycle time = 1 ms for the two channels
- digital/analog conversion response time = 1 ms maximum for a 0-100% step.

NOTE: If nothing is connected on the BMX AMO 0210 analog module and the channels are configured in the range 4..20 mA, there is a detected I/O error as if a wire is broken. For the 0..20 mA range, there is a detected I/O error as if a wire is broken only when the current is greater than 0 mA.

CAUTION

RISK OF INCORRECT DATA

If a signal wire is broken or disconnected, the last measured value is kept.

- Ensure that this does not cause a hazardous situation.
- Do not rely on the value reported. Check the input value at the sensor.

Failure to follow these instructions can result in injury or equipment damage.

Functional Description

Function

The BMX AMO 0210 is a module with 2 analog outputs isolated from each other. This module offers the following ranges for each output, according to the selection made during configuration:

- +/-10 V
- 0...20 mA
- 4...20 mA

Illustration

The BMX AMO 0210 module's illustration is as follows.

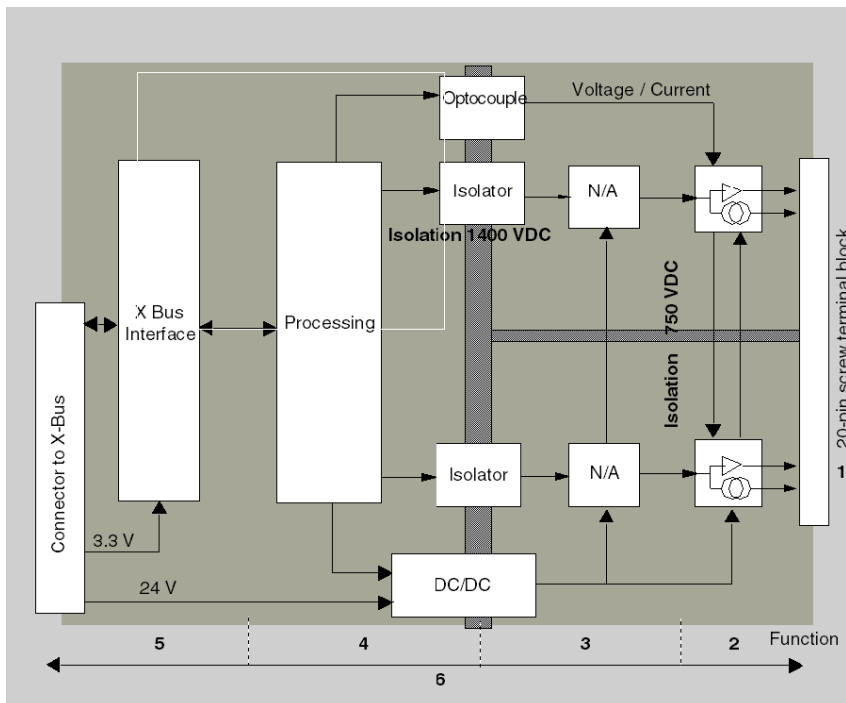

Description.

Address	Process	Characteristics
1	Adapting the outputs	<ul style="list-style-type: none"> physical connection to the process through a 20-pin screw terminal block protecting the module against voltage spikes
2	Adapting the signal to the Actuators	<ul style="list-style-type: none"> the adaptation is performed on voltage or current via software configuration
3	Converting	<ul style="list-style-type: none"> this conversion is performed on 15 bits with a polarity sign reframing the data provided by the program is performed automatically and dynamically by the converter
4	Transforming application data into data directly usable by the digital/analog converter	<ul style="list-style-type: none"> use of factory calibration parameters
5	Communicating with the Application	<ul style="list-style-type: none"> manages exchanges with CPU topological addressing receiving, from the application, configuration parameters for the module and channels, as well as numeric setpoints from the channels sending module status back to application
6	Module monitoring and sending error notifications back to the application	<ul style="list-style-type: none"> output power supply test testing for range overflow on channels testing for output open circuits and short-circuits watchdog test Programmable fallback capabilities

Writing Outputs

The application must provide the outputs with values in the standardized format:

- 10,000 to +10,000 for the +/-10 V range
- 0 to +10,000 in 0-20 mA and 4-20 mA ranges

Digital/Analog Conversion

The digital/analog conversion is performed on:

- 16-bit for the +/-10 V range
- 15-bit in 0-20 mA and 4-20 mA ranges

Overflow Control

Module BMX AMO 0210 allows an overflow control on voltage and current ranges.

The measurement range is divided in three areas.

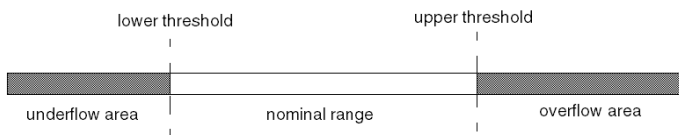

Description:

Designation	Description
Nominal range	measurement range corresponding to the chosen range
Overflow Area	area located beyond the upper threshold
Underflow Area	area located below the lower threshold

Overflow values for the various ranges are as follows.

Range	BMX AMO 0210					
	Underflow Area		Nominal Range		Overflow Area	
+/- 10V	-11,250	-11,001	-11,000	11,000	11,001	11,250
0..20mA	-2,000	-1,001	-1,000	11,000	11,001	12,000
4..20mA	-1,600	-801	-800	10800	10801	11,600

You may also choose the flag for an overflow of the range upper value, for an underflow of the range lower value, or for both.

NOTE: Range under/overflow detection is optional.

Fallback/Maintain or Reset Outputs to Zero

In case of error, and depending on its seriousness, the outputs:

- switch to Fallback/Maintain position individually or together,
- are forced to 0 (0 V or 0 mA).

Various Behaviors of Outputs:

Error	Behavior of Voltage Outputs	Behavior of Current Outputs
Task in STOP mode, or program missing	Fallback/Maintain (channel by channel)	Fallback/Maintain (channel by channel)
Communication interruption		
Configuration Error	0 V (all channels)	0 mA (all channels)
Internal Error in Module		
Output Value out-of-range (range under/overflow)	Value saturated at the defined limit (channel by channel)	Saturated value (channel by channel)
Output short or open circuit	Short-circuit: Maintain (channel by channel)	Open circuit: Maintain (channel by channel)
Module Hot swapping (processor in STOP mode)	0 V (all channels)	0 mA (all channels)
Reloading Program		

Fallback or Maintain at current value is selected during the configuration of the module. The fallback value may be modified from the Debug in Unity Pro or through a program.

⚠ WARNING
UNEXPECTED EQUIPMENT OPERATION
The fallback position should not be used as the sole safety method. If an uncontrolled position can result in a hazard, an independent redundant system must be installed.
Failure to follow these instructions can result in death, serious injury, or equipment damage.

Behavior at Initial Power-Up and When Switched Off.

When the module is switched on or off, the outputs are set to 0 (0 V or 0 mA).

Actuator Alignment

The process of "alignment" consists in eliminating a systematic offset observed with a given actuator, around a specific operating point. This operation compensates for an error linked to the process. Therefore, replacing a module does not require a new alignment. However, replacing the actuator or changing the sensor's operating point does require a new alignment.

Conversion lines are as follows:

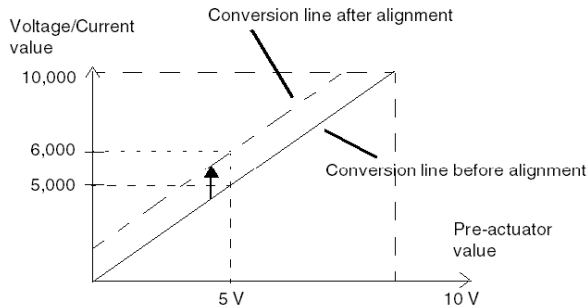

The alignment value is editable from a programming console, even if the program is in RUN Mode. For each output channel, you can:

- view and modify the initial output target value
- save the alignment value
- determine whether the channel already has an alignment

The maximum offset between the measured value and the corrected output value (aligned value) may not exceed +/- 1.500.

NOTE: To align several analog channels on the BMX AMO/AMI/AMM/ART modules, we recommend proceeding channel by channel. Test each channel after alignment before moving to the next channel in order to apply the parameters correctly.

Wiring Precautions

Introduction

In order to protect the signal from outside interference induced in series mode and interference in common mode, we recommend that you take the following precautions.

Cable Shielding

Connect the cable shielding to the grounding bar. Clamp the shielding to the shield bar on the module side. Use the shielding connection kit BMXXSP**** (see page 50) to connect the shielding.

⚠ DANGER

HAZARD OF ELECTRIC SHOCK, EXPLOSION, OR ARC FLASH

While mounting / removing the modules:

- make sure that each terminal block is still connected to the shield bar and
- disconnect voltage supplying sensors and pre-actuators.

Failure to follow these instructions will result in death or serious injury.

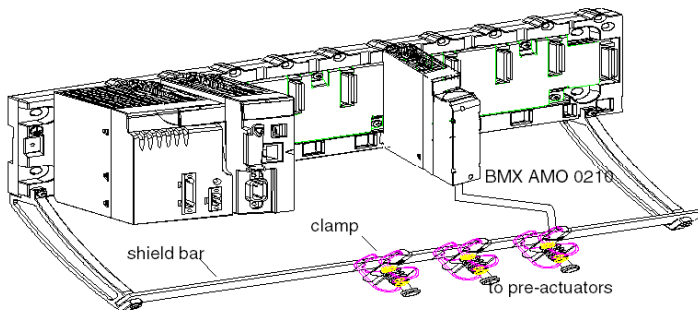

Using Pre-Actuators Referenced in Relation to the Ground

There are no specific technical constraints for referencing pre-actuators to the ground. It is nevertheless preferable to avoid returning a remote ground potential to the terminal; this may be very different to the ground potential close by.

Sensors and other peripherals may be connected to a grounding point some distance from the module. Such remote ground references may carry considerable potential differences with respect to local ground. Induced currents do not affect the measurement or integrity of the system.

DANGER

HAZARD OF ELECTRIC SHOCK

Ensure that sensors and others peripherals are not exposed through grounding points to voltage potential greater than acceptable limits.

Failure to follow these instructions will result in death or serious injury.

Electromagnetic hazard instructions

CAUTION

UNEXPECTED BEHAVIOR OF APPLICATION

Follow those instructions to reduce electromagnetic perturbations:

- use the shielding connection kit BMXXSP**** (*see page 50*) to connect the shielding without programmable filtering,

Electromagnetic perturbations may lead to an unexpected behavior of the application.

Failure to follow these instructions can result in injury or equipment damage.

Wiring Diagram

Introduction

The actuators are connected using the 20-point terminal block.

Illustration

The current loop is self-powered by the output and does not request any external supply. The terminal block connection and the actuators wiring are as follows.

Cabling view

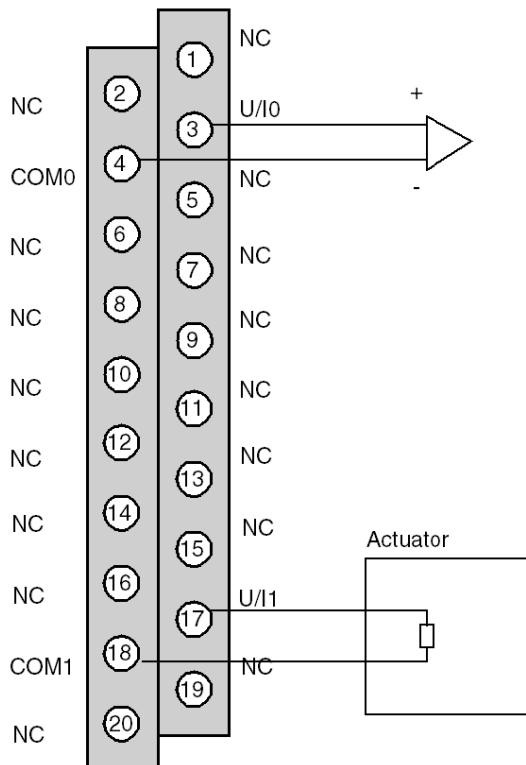

U/Ix + pole input for channel x

COMx - pole input for channel x

Channel 0: Voltage actuator

Channel 1: Current actuator

Use of the TELEFAST ABE-7CPA21 Wiring Accessory

Introduction

The BMXAMO0210 module can be connected to a TELEFAST ABE-7CPA21 accessory.
The TELEFAST ABE-7CPA21 is connected as shown in the illustration below:

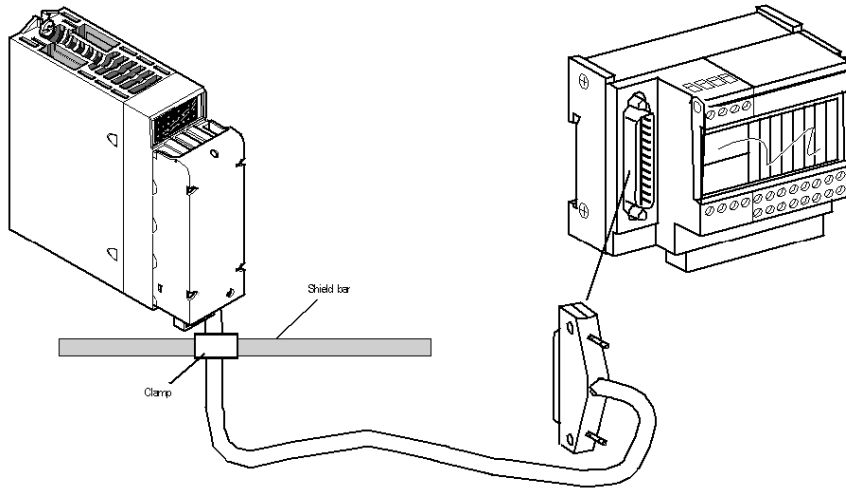

The module is connected using one of the following cables:

- BMX FCA 150: length 1.5 m
- BMX FCA 300: length 3 m
- BMX FCA 500: length 5 m

Connecting Actuators

The BMX AMO 0210 analog outputs are accessible on the terminal block of the TELEFAST ABE-7CPA21 as follows:

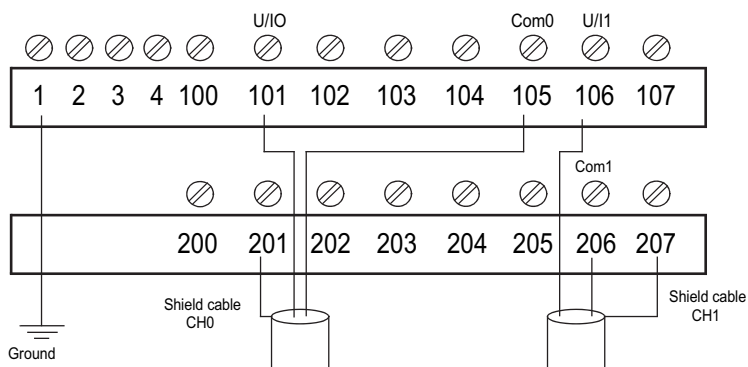

The following table shows the distribution of analog outputs of the on the TELEFAST ABE-7CPA21 terminal block with a BMX FCA ••0 cable:

TELEFAST 2 terminal block number	25 pin SubD connector pin number	AMO0210 pin out	Signal type	TELEFAST 2 terminal block number	25 pin SubD connector pin number	AMO0210 pin out	Signal type
1	/		Ground	Supp 1	/		Ground
2	/		STD (1)	Supp 2	/		Ground
3	/		STD (1)	Supp 3	/		Ground
4	/		STD (2)	Supp 4	/		Ground
100	1			200	14		
101	2	3	U/I0	201	/		Ground
102	15		NC	202	3		
103	16		NC	203	/		Ground
104	4		NC	204	17		NC
105	5	4	COM 0	205	/		Ground
106	18	17	U/I1	206	6	18	Com 1
107	19		NC	207	/		Ground

NC: Not Connected

NOTE: For the ground connection use the additional terminal block ABE-7BV20.

Chapter 8

BMX AMO 0410 Analog Output Module

Subject of this Chapter

This chapter presents the BMX AMO 0410 module, its characteristics, and explains how it is connected to the various pre-actuators and actuators.

What Is in This Chapter?

This chapter contains the following topics:

Topic	Page
Presentation	166
Characteristics	167
Functional Description	169
Wiring Precautions	174
Wiring Diagram	176
Use of the TELEFAST ABE-7CPA21 Wiring Accessory	177

Presentation

Function

The BMX AMO 0410 is a high density output analog module fitted with four isolated channels. It offers the following ranges for each output:

- Voltage +/-10 V
- Current 0..20 mA and 4..20 mA

The range is selected during configuration.

Illustration

The following graphic shows the BMX AMO 0410 analog output module:

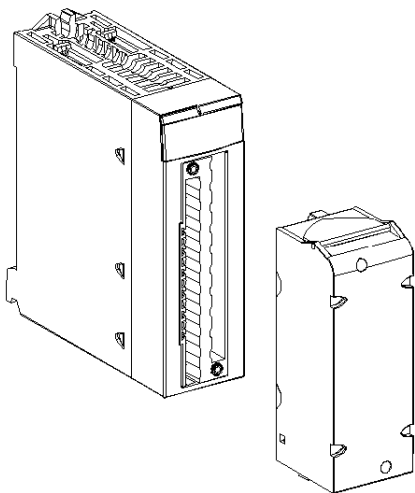

NOTE: The terminal block is supplied separately.

Characteristics

General Characteristics

The general characteristics for the BMX AMO 0410 and BMX AMO 0410H modules are as follows:

Type of outputs	High level Fast outputs	
Nature of outputs	Voltage or Current configured by software	
Number of channels	4	
Digital/Analog converter resolution	16 bits	
Output refresh time	1 ms	
Power supply for outputs	by the module	
Types of protection	From short circuits and overloads (Voltage output)	
Isolation:		
● Between channels	750 VDC	
● Between channels and bus	1400 VDC	
● Between channels and ground	1400 VDC	
Measurement error for standard module:		
● At 25°C (77°F)	0.10% of FS (1)	
● Maximum in the temperature range 0..60°C (32..140°F)	0.20% of FS (1)	
Measurement error for ruggedized:		
● At 25°C (77°F)	0.10% of FS (1)	
● Maximum in the temperature range -25..70°C (-13..158°F)	0.45% of FS (1)	
Temperature drift	45 ppm/°C	
Monotonicity	Yes	
Non linearity	0.1% of FS	
AC output ripple	2 mV rms on 50 Ω	
Power consumption (3.3 V)	Typical	0.48 W
	Maximum	0.61 W
Power consumption (24 V)	Typical	3.0 W
	Maximum	3.2 W
Legend		
(1) FS: Full Scale		

Voltage Output

The BMX AMO 0410 and BMX AMO 0410H voltage outputs have the following characteristics:

Nominal variation range	+/-10 V
Maximum variation range	+/- 10.50 V
Analog resolution	0.37 mV
Load impedance	1 KΩ minimum
Detection type	Short circuits

Current Output

The BMX AMO 0410 and BMX AMO 0410H current outputs have the following characteristics:

Nominal variation range	0..20 mA, 4..20 mA
Available maximum current	21 mA
Analog resolution	0.74 μA
Load impedance	500 Ω maximum
Detection type	Open circuit (1)
Legend	
(1) The open circuit detection is physically detected by the module if the target current value is different from 0 mA.	

Response time of Outputs

The maximum delay between transmission of the output value on the PLC bus and its effective positioning on the terminal block is less than 2 ms:

- Internal cycle time = 1 ms for the four channels
- Digital/Analog conversion response time = 1 ms maximum for a 0-100% step.

NOTE: If nothing is connected on the BMX AMO 0410 analog module and the channels are configured in the range 4..20 mA, there is a detected I/O error as if a wire is broken.

For the 0..20 mA range, there is a detected I/O error as if a wire is broken only when the current is greater than 0 mA.

CAUTION

RISK OF INCORRECT DATA

If a signal wire is broken or disconnected, the last measured value is kept.

- Ensure that this does not cause a hazardous situation.
- Do not rely on the value reported. Check the input value at the sensor.

Failure to follow these instructions can result in injury or equipment damage.

Functional Description

Function

The BMX AMO 0410 is a high density output analog module fitted with four isolated channels. This module offers the following ranges for each output, according to the selection made during configuration:

- +/-10 V
- 0...20 mA
- 4...20 mA

Illustration

The BMX AMO 0410 module's illustration is as follows:

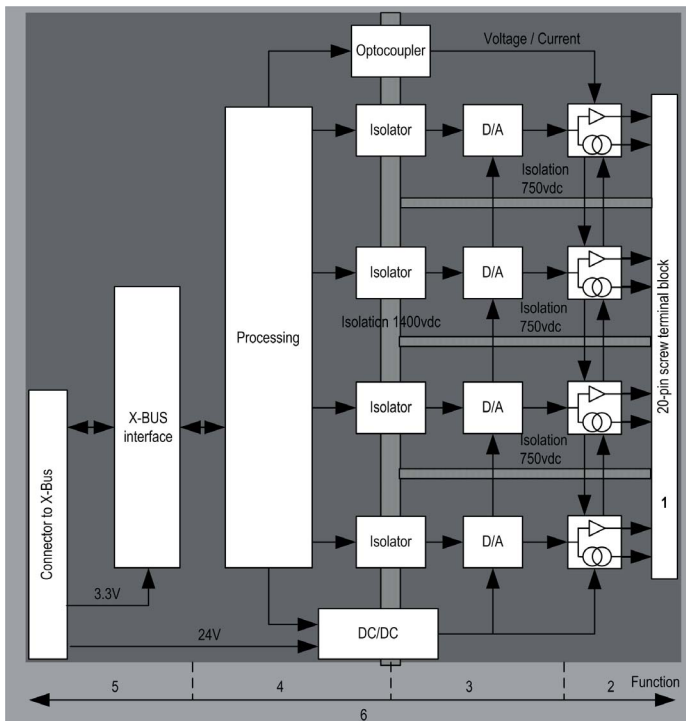

Description:

Address	Process	Characteristics
1	Adapting the outputs	<ul style="list-style-type: none"> ● physical connection to the process through a 20-pin screw terminal block ● protecting the module against voltage spikes
2	Adapting the signal to the Actuators	<ul style="list-style-type: none"> ● the adaptation is performed on voltage or current via software configuration
3	Converting	<ul style="list-style-type: none"> ● this conversion is performed on 15 bits with a polarity sign ● reframing the data provided by the program is performed automatically and dynamically by the converter
4	Transforming application data into data directly usable by the digital/analog converter	<ul style="list-style-type: none"> ● use of factory calibration parameters
5	Communicating with the Application	<ul style="list-style-type: none"> ● manages exchanges with CPU ● topological addressing ● from the application, receiving the configuration parameters for the module and channels as well as numeric set points from the channels ● sending module status back to application
6	Module monitoring and sending error notifications back to the application	<ul style="list-style-type: none"> ● output power supply test ● testing for range overflow on channels ● testing for output open circuits and short-circuits ● watchdog test ● Programmable fallback capabilities

Writing Outputs

The application must provide the outputs with values in the standardized format:

- -10,000 to +10,000 for the +/-10 V range
- 0 to +10,000 in 0-20 mV and 4-20 mA ranges

Digital/Analog Conversion

The digital/analog conversion is performed on:

- 16-bit for the +/-10 V range
- 15-bit in 0-20 mA and 4-20 mA ranges

Overflow Control

Module BMX AMO 0410 allows an overflow control on voltage and current ranges.

The measurement range is divided in three areas:

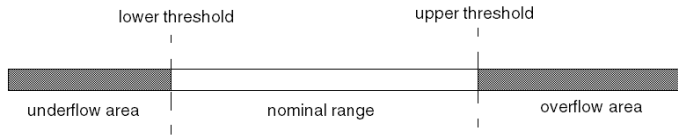

Description:

Designation	Description
Nominal range	measurement range corresponding to the chosen range
Overflow Area	area located beyond the upper threshold
Underflow Area	area located below the lower threshold

Overflow values for the various ranges are as follows:

Range	BMX AMO 0410					
	Underflow Area		Nominal Range		Overflow Area	
+/- 10V	-10,500	-10,301	-10,300	10,300	10,301	10,500
0..20mA	-2,000	-1,001	-1,000	10,300	10,301	10,500
4..20mA	-1,600	-801	-800	10,300	10,301	10,500

You may also choose the flag for an overflow of the range upper value, for an underflow of the range lower value, or for both.

NOTE: Range under/overflow detection is optional.

Fallback/Maintain or Reset Outputs to Zero

If an error is detected, and depending on its seriousness, the outputs:

- switch to Fallback/Maintain position individually or together,
- are forced to 0 (0 V or 0 mA).

Various Behaviors of Outputs:

Error	Behavior of Voltage Outputs	Behavior of Current Outputs
Task in STOP mode, or program missing	Fallback/Maintain (channel by channel)	Fallback/Maintain (channel by channel)
Communication interruption		
Configuration Error	0 V (all channels)	0 mA (all channels)
Internal Error in Module		
Output Value out-of-range (range under/overflow)	Value saturated at the defined limit (channel by channel)	Saturated value (channel by channel)
Output short or open circuit	Short-circuit: Maintain (channel by channel)	Open circuit: Maintain (channel by channel)
Module Hot swapping (processor in STOP mode)	0 V (all channels)	0 mA (all channels)
Reloading Program		

Fallback or Maintain at current value is selected during the configuration of the module. The fallback value may be modified from the Debug in Unity Pro or through a program.

⚠ WARNING
UNEXPECTED EQUIPMENT OPERATION
The fallback position should not be used as the sole safety method. If an uncontrolled position can result in a hazard, an independent redundant system must be installed.
Failure to follow these instructions can result in death, serious injury, or equipment damage.

Behavior at Initial Power-Up and When Switched Off.

When the module is switched on or off, the outputs are set to 0 (0 V or 0 mA).

Actuator Alignment

The process of "alignment" consists in eliminating a systematic offset observed with a given actuator, around a specific operating point. This operation compensates for an error linked to the process. Therefore, replacing a module does not require a new alignment. However, replacing the actuator or changing the sensor's operating point does require a new alignment.

Conversion lines are as follows:

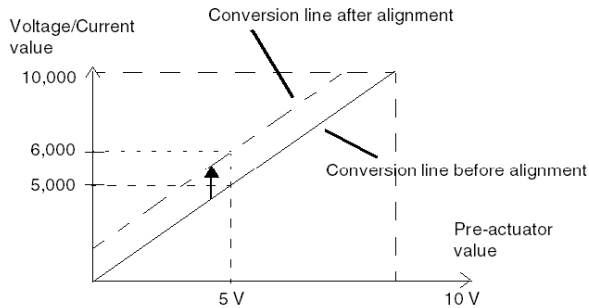

The alignment value is editable from a programming console, even if the program is in RUN Mode. For each output channel, you can:

- view and modify the initial output target value
- save the alignment value
- determine whether the channel already has an alignment

The maximum offset between the measured value and the corrected output value (aligned value) may not exceed +/- 1.500.

NOTE: To align several analog channels on the BMX AMO/AMI/AMM/ART modules, we recommend proceeding channel by channel. Test each channel after alignment before moving to the next channel in order to apply the parameters correctly.

Wiring Precautions

Introduction

In order to protect the signal from outside interference induced in series mode and interference in common mode, we recommend that you take the following precautions.

Cable Shielding

Connect the cable shielding to the grounding bar. Clamp the shielding to the shield bar on the module side. Use the shielding connection kit BMXXSP**** (see page 50) to connect the shielding.

⚠ DANGER

HAZARD OF ELECTRIC SHOCK, EXPLOSION, OR ARC FLASH

While mounting / removing the modules:

- make sure that each terminal block is still connected to the shield bar and
- disconnect voltage supplying sensors and pre-actuators.

Failure to follow these instructions will result in death or serious injury.

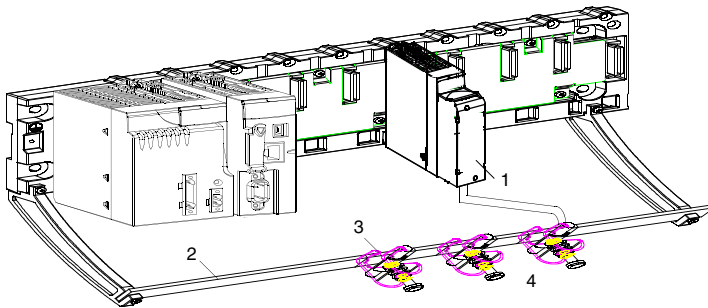

- 1 BMX AMO 0410
- 2 Shield bar
- 3 Clamp
- 4 To pre-actuators

Using Pre-Actuators Referenced in Relation to the Ground

There are no specific technical constraints for referencing pre-actuators to the ground. It is nevertheless preferable to avoid returning a remote ground potential to the terminal that may be different to the ground potential close by.

DANGER

HAZARD OF ELECTRIC SHOCK

Sensors and other peripherals may be connected to a grounding point some distance from the module. Such remote ground references may carry considerable potential differences with respect to local ground. Ensure that:

- potentials greater than safety limits cannot exist,
- induced currents do not affect the measurement or integrity of the system.

Failure to follow these instructions will result in death or serious injury.

Electromagnetic hazard instructions

CAUTION

UNEXPECTED BEHAVIOR OF APPLICATION

Follow those instructions to reduce electromagnetic perturbations:

- use the shielding connection kit BMXXSP•••• (see page 50) to connect the shielding without programmable filtering,

Electromagnetic perturbations may lead to an unexpected behavior of the application.

Failure to follow these instructions can result in injury or equipment damage.

Wiring Diagram

Introduction

The actuators are connected using the 20-pin terminal block.

Illustration

The current loop is self-powered by the output and does not request any external supply. The terminal block connection and the actuators wiring are as follows:

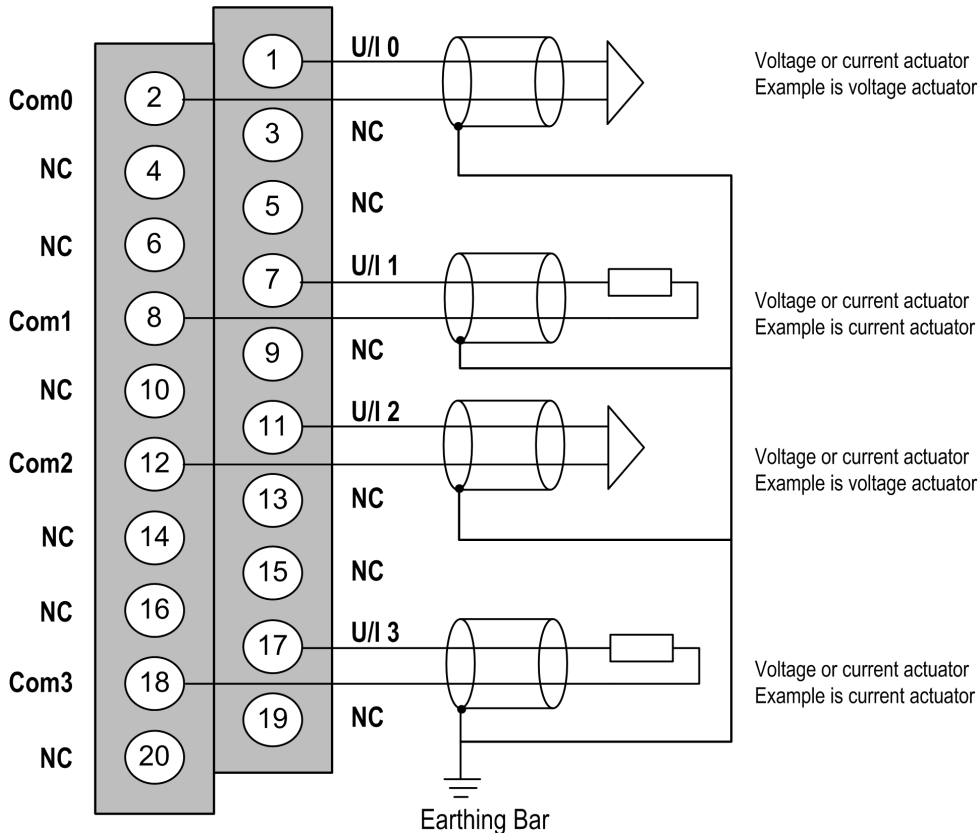

U/Ix + pole input for channel x
 COMx - pole input for channel x
 Channel 0: Voltage actuator
 Channel 1: Current actuator

Use of the TELEFAST ABE-7CPA21 Wiring Accessory

Introduction

The BMX AMO 0410 module can be connected to a TELEFAST ABE-7CPA21 accessory.

The TELEFAST ABE-7CPA21 is connected as shown in the illustration below:

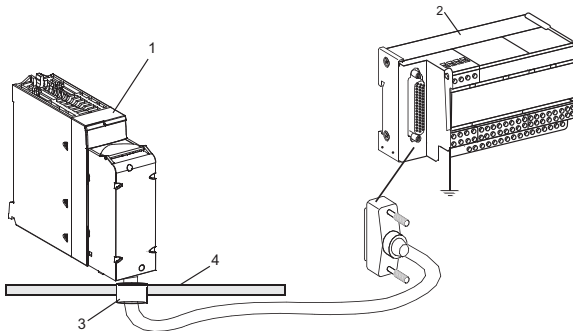

- 1 BMX AMO 0410
- 2 Telefast ABE-7CPA21
- 3 Clamp
- 4 Shield bar

The module is connected using one of the following cables:

- BMX FCA 150: length 1.5 m (4.92 ft)
- BMX FCA 300: length 3 m (9.84 ft)
- BMX FCA 500: length 5 m (16.40 ft)

Connecting Actuators

The analog outputs are accessible on the terminals of the TELEFAST ABE-7CPA21 as follows:

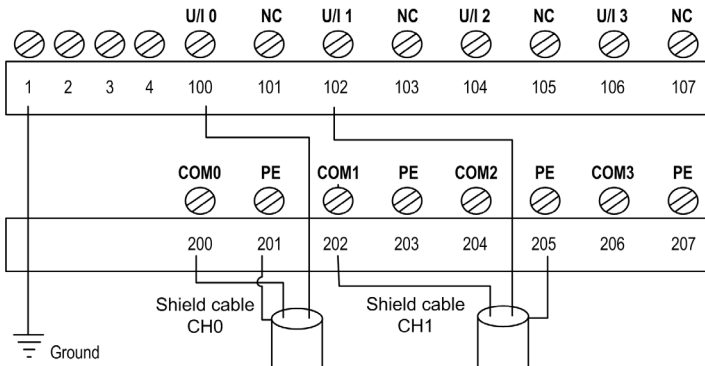

The following table shows the distribution of analog channels on the TELEFAST ABE-7CPA21 terminal block with a BMX FCA ••0 cable:

TELEFAST 2 terminal block number	25 pin SubD connector pin number	AMO0410 pin out	Signal type	TELEFAST 2 terminal block number	25 pin SubD connector pin number	AMO0410 pin out	Signal type
1	/		Ground	Supp 1	/		Ground
2	/		STD (1)	Supp 2	/		Ground
3	/		STD (1)	Supp 3	/		Ground
4	/		STD (2)	Supp 4	/		Ground
100	1	1	U/I0	200	14	2	Com 0
101	2		NC	201	/		Ground
102	15	7	U/I1	202	3	8	Com 1
103	16		NC	203	/		Ground
104	4	11	U/I2	204	17	12	Com 2
105	5		NC	205	/		Ground
106	18	17	U/I3	206	6	18	Com 3
107	19		NC	207	/		Ground

NC: Not Connected

NOTE: The strap with the ABE-7CPA21 must be removed from the terminal, otherwise the signal ground of channel 0 will be connected to earth.

For the ground connection use the additional terminal block ABE-7BV20.

Chapter 9

BMX AMO 0802 Analog Output Module

Subject of this Chapter

This chapter presents the BMX AMO 0802 module, its characteristics, and explains how it is connected to the various pre-actuators and actuators.

What Is in This Chapter?

This chapter contains the following topics:

Topic	Page
Presentation	180
Characteristics	181
Functional Description	183
Wiring Precautions	188
Wiring Diagram	190
Use of the TELEFAST ABE-7CPA02 Wiring Accessory	191

Presentation

Function

The BMX AMO 0802 is a high density output analog module fitted with 8 non-isolated channels. It offers the following current ranges for each output:

- 0..20 mA
- 4..20 mA

The range is selected during configuration.

Illustration

The following graphic shows the BMX AMO 0802 analog output module:

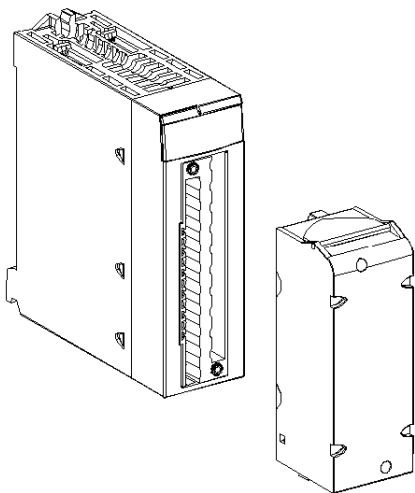

NOTE: The terminal block is supplied separately.

Characteristics

General Characteristics

The general characteristics for the BMX AMO 0802 modules are as follows:

Type of outputs	Non-isolated high level outputs with common point	
Nature of outputs	Current	
Number of channels	8	
Digital/Analog converter resolution	16 bits	
Output refresh time	4 ms	
Power supply for outputs	by the module	
Types of protection	Outputs protected to short circuits and permanent overloads	
Isolation:		
<ul style="list-style-type: none"> ● Between channels ● Between channels and bus ● Between channels and ground 	Non-isolated 1400 VDC 1400 VDC	
Measurement error for standard module:		
<ul style="list-style-type: none"> ● At 25°C (77°F) ● Maximum in the temperature range 0..60°C (32..140°F) 	0.10% of FS (1) 0.25% of FS (1)	
Measurement error for ruggedized:		
<ul style="list-style-type: none"> ● At 25°C (77°F) ● Maximum in the temperature range -25..70°C (-13..158°F) 	0.10% of FS (1) 0.45% of FS (1)	
Temperature drift	45 ppm/°C	
Monotonicity	Yes	
Non linearity	0.1% of FS	
AC output ripple	2 mV rms on 50 Ω	
Power consumption (3.3 V)	Typical	0.35 W
	Maximum	0.48 W
Power consumption (24 V)	Typical	3.40 W
	Maximum	3.70 W
Legend		
(1) FS: Full Scale		

Current Output

The BMX AMO 0802 and BMX AMO 0802H current outputs have the following characteristics:

Nominal variation range	0..20 mA, 4..20 mA
Available maximum current	21 mA
Analog resolution	0.74 μ A
Load impedance	350 Ω maximum
Detection type	Open circuit (1)
Legend	
(1) The open circuit detection is physically detected by the module if the target current value is different from 0 mA.	

Response time of Outputs

The maximum delay between transmission of the output value on the PLC bus and its effective positioning on the terminal block is less than 5 ms:

- Internal cycle time = 4 ms for the eight channels
- Digital/Analog conversion response time = 1 ms maximum for a 0-100% step.

NOTE: If nothing is connected on the BMX AMO 0802 analog module and the channels are configured in the range 4..20 mA, there is a detected I/O error as if a wire is broken. For the 0..20 mA range, there is a detected I/O error as if a wire is broken only when the current is greater than 0 mA.

CAUTION

RISK OF INCORRECT DATA

If a signal wire is broken or disconnected, the last measured value is kept.

- Ensure that this does not cause a hazardous situation.
- Do not rely on the value reported. Check the input value at the sensor.

Failure to follow these instructions can result in injury or equipment damage.

Functional Description

Function

The BMX AMO 0802 is a high density output analog module fitted with 8 non-isolated channels. It offers the following current ranges for each output:

- 0..20 mA
- 4..20 mA

The range is selected during configuration.

Illustration

The BMX AMO 0802 module's illustration is as follows:

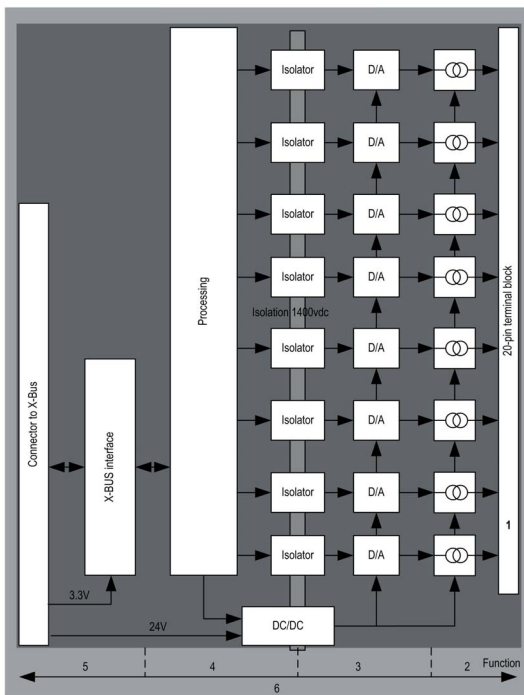

Description:

Address	Process	Characteristics
1	Adapting the outputs	<ul style="list-style-type: none"> physical connection to the process through a 20-pin screw terminal block protecting the module against voltage spikes
2	Adapting the signal to the Actuators	<ul style="list-style-type: none"> the adaptation is performed on current via software configuration
3	Converting	<ul style="list-style-type: none"> this conversion is performed on 15 bits with a polarity sign reframing the data provided by the program is performed automatically and dynamically by the converter
4	Transforming application data into data directly usable by the digital/analog converter	<ul style="list-style-type: none"> use of factory calibration parameters
5	Communicating with the Application	<ul style="list-style-type: none"> manages exchanges with CPU topological addressing from the application, receiving the configuration parameters for the module and channels as well as numeric set points from the channels sending module status back to application
6	Module monitoring and sending error notifications back to the application	<ul style="list-style-type: none"> output power supply test testing for range overflow on channels testing for output open circuits and short-circuits watchdog test Programmable fallback capabilities

Writing Outputs

The application must provide the outputs with values in the standardized format: 0 to +10,000 in 0..20 mV and 4..20 mA ranges.

Digital/Analog Conversion

The digital/analog conversion is performed on: 15-bit in 0..20 mA and 4..20 mA ranges.

Overflow Control

Module BMX AMO 0802 only allows an overflow control on current ranges.

The measurement range is divided in three areas:

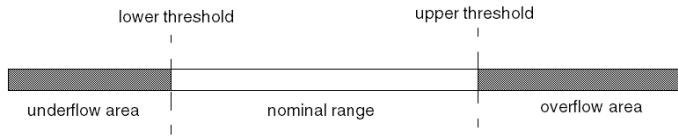

Description:

Designation	Description
Nominal range	measurement range corresponding to the chosen range
Overflow Area	area located beyond the upper threshold
Underflow Area	area located below the lower threshold

Overflow values for the various ranges are as follows:

Range	BMX AMO 0802					
	Underflow Area		Nominal Range		Overflow Area	
0..20mA	-2,000	-1,001	-1,000	10,300	10,301	10,500
4..20mA	-1,600	-801	-800	10,300	10,301	10,500

You may also choose the flag for an overflow of the range upper value, for an underflow of the range lower value, or for both.

NOTE: Range under/overflow detection is optional.

Fallback/Maintain or Reset Outputs to Zero

If an error is detected, and depending on its seriousness, the outputs:

- switch to Fallback/Maintain position individually or together,
- are forced to 0 mA.

Various Behaviors of Outputs:

Error	Behavior of Outputs
Task in STOP mode, or program missing	Fallback/Maintain (channel by channel)
Communication interruption	
Configuration Error	0 mA (all channels)
Internal Error in Module	
Output Value out-of-range (range under/overflow)	Saturated value (channel by channel)
Output open circuit	Maintain (channel by channel)
Module Hot swapping (processor in STOP mode)	0 mA (all channels)
Reloading Program	

Fallback or Maintain at current value is selected during the configuration of the module. The fallback value may be modified from the Debug in Unity Pro or through a program.

⚠ WARNING
UNEXPECTED EQUIPMENT OPERATION
The fallback position should not be used as the sole safety method. If an uncontrolled position can result in a hazard, an independent redundant system must be installed.
Failure to follow these instructions can result in death, serious injury, or equipment damage.

Behavior at Initial Power-Up and When Switched Off.

When the module is switched on or off, the outputs are set to 0 mA.

Actuator Alignment

The process of "alignment" consists in eliminating a systematic offset observed with a given actuator, around a specific operating point. This operation compensates for an error linked to the process. Therefore, replacing a module does not require a new alignment. However, replacing the actuator or changing the sensor's operating point does require a new alignment.

Conversion lines are as follows:

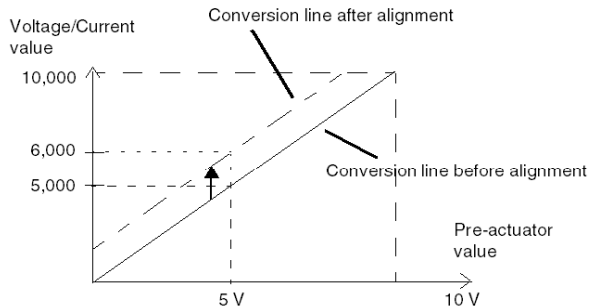

The alignment value is editable from a programming console, even if the program is in RUN Mode. For each output channel, you can:

- view and modify the initial output target value
- save the alignment value
- determine whether the channel already has an alignment

The maximum offset between the measured value and the corrected output value (aligned value) may not exceed +/- 1.500.

NOTE: To align several analog channels on the BMX AMO/AMI/AMM/ART modules, we recommend proceeding channel by channel. Test each channel after alignment before moving to the next channel in order to apply the parameters correctly.

Wiring Precautions

Introduction

In order to protect the signal from outside interference induced in series mode and interference in common mode, we recommend that you take the following precautions.

Cable Shielding

Connect the cable shielding to the grounding bar. Clamp the shielding to the shield bar on the module side. Use the shielding connection kit BMXXSP**** (see page 50) to connect the shielding.

⚠ DANGER

HAZARD OF ELECTRIC SHOCK, EXPLOSION, OR ARC FLASH

While mounting / removing the modules:

- make sure that each terminal block is still connected to the shield bar and
- disconnect voltage supplying sensors and pre-actuators.

Failure to follow these instructions will result in death or serious injury.

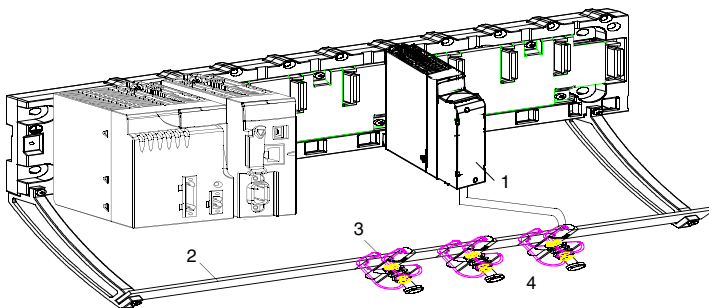

- 1 BMX AMO 0802
- 2 Shield bar
- 3 Clamp
- 4 To pre-actuators

Using Pre-Actuators Referenced in Relation to the Ground

There are no specific technical constraints for referencing pre-actuators to the ground. It is nevertheless preferable to avoid returning a remote ground potential to the terminal that may be different to the ground potential close by.

NOTE: Sensors and other peripherals may be connected to a grounding point some distance from the module. Such remote ground references may carry considerable potential differences with respect to local ground. Induced currents do not affect the measurement or integrity of the system.

DANGER

HAZARD OF ELECTRIC SHOCK

Ensure that sensors and others peripherals are not exposed through grounding points to voltage potential greater than acceptable limits.

Failure to follow these instructions will result in death or serious injury.

Electromagnetic hazard instructions

CAUTION

UNEXPECTED BEHAVIOR OF APPLICATION

Follow those instructions to reduce electromagnetic perturbations:

- use the shielding connection kit BMXXSP**** (*see page 50*) to connect the shielding without programmable filtering,

Electromagnetic perturbations may lead to an unexpected behavior of the application.

Failure to follow these instructions can result in injury or equipment damage.

Wiring Diagram

Introduction

The actuators are connected using the 20-pin terminal block.

Illustration

The current loop is self-powered by the output and does not request any external supply. The terminal block connection and the actuators wiring are as follows:

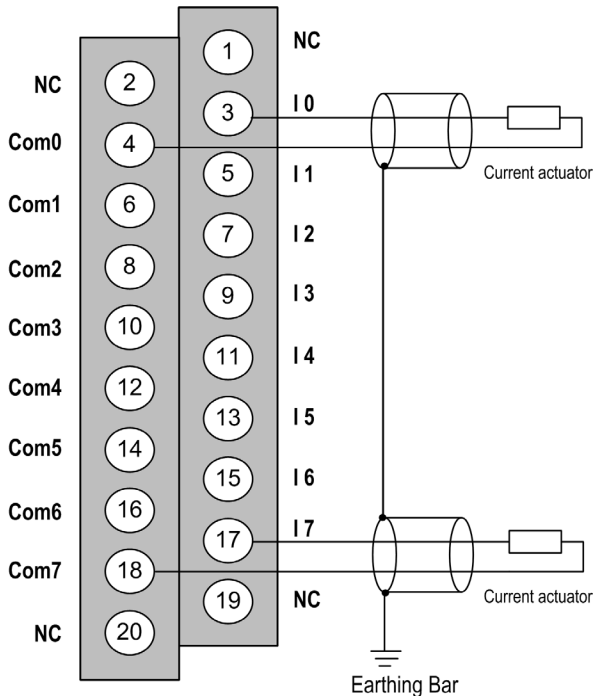

I_x + pole input for channel x.

COM_x - pole input for channel x, COM_x are connected together internally.

Wiring Accessories

Two cords BMX FTA 152/302 are provided in two lengths (1.5m (4.92 ft), 3m (9.84 ft)) to connect the module to a Telefast interface ABE7CPA02 (*see page 191*).

Use of the TELEFAST ABE-7CPA02 Wiring Accessory

Introduction

The BMX AMO 0802 module can be connected to a TELEFAST ABE-7CPA02 accessory.

The module is connected using one of the following cables:

- BMX FTA 152: length 1.5 m (4.92 ft)
- BMX FTA 302: length 3 m (9.84 ft)

Connecting Modules

The TELEFAST ABE-7CPA02 is connected as shown in the illustration below:

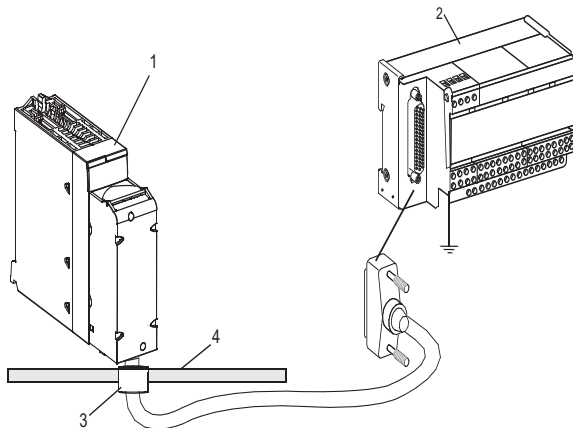

- 1 BMX AMO 0802
- 2 Telefast ABE-7CPA02
- 3 Clamp
- 4 Shield bar

Connecting Actuators

Actuators may be connected to the ABE-7CPA02 accessory as shown in the illustration (see page 190).

The following table shows the distribution of analog channels on TELEFAST 2 terminal blocks with the reference ABE-7CPA02:

TELEFAST 2 terminal block number	25 pin SubD connector pin number	AMO0802 pin out	Signal type	TELEFAST 2 terminal block number	25 pin SubD connector pin number	AMO0802 pin out	Signal type
1	/		Ground	Supp 1	/		Ground
2	/		STD (1)	Supp 2	/		Ground
3	/		STD (1)	Supp 3	/		Ground
4	/		STD (2)	Supp 4	/		Ground
100	1	3	I0	200	14	4	COM0
101	2		NC	201	/		Ground
102	15	5	I1	202	3	6	COM1
103	16		NC	203	/		Ground
104	4	7	I2	204	17	8	COM2
105	5		NC	205	/		Ground
106	18	9	I3	206	6	10	COM3
107	19		NC	207	/		Ground
108	7	11	I4	208	20	12	COM4
109	8		NC	209	/		Ground
110	21	13	I5	210	9	14	COM5
111	22		NC	211	/		Ground
112	10	15	I6	212	23	16	COM6
113	11		NC	213	/		Ground
114	24	17	I7	214	12	18	COM7
115	25		NC	215	/		Ground

Ix: + pole voltage input for channel x
 COMx: - pole voltage or current input for channel x
 NC: Not Connected

NOTE: The strap must be removed from the ABE-7CPA02 terminal, otherwise the signal ground of channels will be connected with earth.
 For the ground connection use the additional terminal block ABE-7BV20.

Chapter 10

BMX AMM 0600 Analog Input/Output Module

Subject of this Chapter

This chapter presents the BMX AMM 0600 module, its characteristics, and explains how it is connected to the various sensors and pre-actuators.

What Is in This Chapter?

This chapter contains the following topics:

Topic	Page
Presentation	194
Characteristics	195
Functional Description	199
Wiring Precautions	210
Wiring Diagram	213

Presentation

Function

The BMX AMM 0600 Input/Output module combines 4 non-isolated analog inputs with 2 non-isolated analog outputs.

The BMX AMM 0600 module offers the following range, according to the selection made during configuration:

- Voltage input range ± 10 V/0..10 V/0..5 V/1..5 V
- Current input range 0...20 mA/4...20 mA
- Voltage output range ± 10 V
- Current output range 0...20 mA/4...20 mA

Illustration

BMX AMM 0600 analog input/output module looks like this.

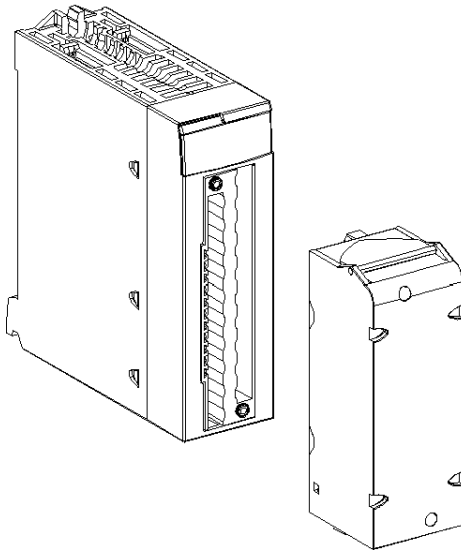

NOTE: The 20-pin terminal block is supplied separately.

Characteristics

General Inputs Characteristics

The **BMX AMM 0600** and **BMX AMM 0600H** general input characteristics are as follows:

Type of inputs		Non-isolated single ended inputs
Nature of inputs		Voltage / Current
Number of channels		4 inputs
Acquisition cycle time:		
<ul style="list-style-type: none"> fast (periodic acquisition for the declared channels used) 		1 ms + 1 ms x number of channels used
<ul style="list-style-type: none"> default (periodic acquisition for all channels) 		5 ms
Resolution		14-bit in +/- 10 V 12-bit in 0...5 V
Digital filtering		First order
Isolation:		
<ul style="list-style-type: none"> between inputs channels group and output channels group 		750 VDC
<ul style="list-style-type: none"> between channels and bus 		1400 VDC
<ul style="list-style-type: none"> between channels and ground 		1400 VDC
Maximum overload authorized for inputs:		Voltage inputs: +/- 30 VDC Current inputs: +/- 90 mA
Power consumption (3.3 V)	Typical	0.35 W
	Maximum	0.48 W
Power consumption (24 V)	Typical	1.3 W
	Maximum	2.8 W

Input Measurement Range

The **BMX AMM 0600** and **BMX AMM 0600H** have the following input measurement range characteristics:

Measurement range	+/-10 V; 0..10 V; 0..5 V; 1..5 V	0..20 mA/4..20 mA
Maximum conversion value	+/-11.25 V	0..30 mA
Resolution	1.42 mV	5.7 µA
Input impedance	10 MΩ	250 Ω internal conversion resistor
Precision of the internal conversion resistor	-	0.1%-15 ppm/°C
Measurement error for inputs for standard modules:		
<ul style="list-style-type: none"> At 25°C (77°F) Maximum in the temperature range 0...60°C (-32...140°F) 	0.25% of FS(1) 0.35% of FS(1)	0.35% of FS(1, 2) 0.50% of FS(1, 2)
Measurement error for inputs for Hardened modules:		
<ul style="list-style-type: none"> At 25°C (77°F) Maximum in the temperature range -25...70°C (-13...158°F) 	0.25% of FS(1) 0.40% of FS(1)	0.35% of FS(1, 2) 0.60% of FS(1, 2)
Input temperature drift	30 ppm/°C	50 ppm/°C
Monotonicity	Yes	Yes
Non linearity	0.10% of FS	0.10% of FS
Legend:		
(1) FS: Full Scale		
(2) With conversion resistor error		

NOTE: If nothing is connected on **BMX AMM 0600** and **BMX AMM 0600H** analog input/output module and if channels are configured (range 4-20 mA or 1-5 V) a broken wire causes a detected I/O error.

General Output Characteristics

The **BMX AMM 0600** and **BMX AMM 0600H** general output characteristics are as follows:

Type of Outputs	2 Non-isolated Outputs
Range configuration	Voltage or self-powered current range selection by firmware

Voltage range

The **BMX AMM 0600** and **BMX AMM 0600H** voltage range has the following characteristics:

Nominal variation range	+/-10 V
Maximum variation range	+/- 11.25 V
Voltage resolution	12 bits
Measurement error for standard module:	
<ul style="list-style-type: none"> ● At 25°C (77°F) ● Maximum in the temperature range 0...60°C (-32...140°F) 	<ul style="list-style-type: none"> 0.25% of FS(1) 0.60% of FS(1)
Measurement error for ruggedized module:	
<ul style="list-style-type: none"> ● At 25°C (77°F) ● Maximum in the temperature range -25...70°C (-13...158°F) 	<ul style="list-style-type: none"> 0.25% of FS(1) 0.80% of FS(1)
Temperature drift	100 ppm/°C
Monotonicity	Yes
Non linearity	0.1% of FS
AC output ripple	2 mV rms on 50 Ω BW < 25MHz
Load impedance	1 KΩ minimum
Detection type	Short circuits and overloads

Current Range

The **BMX AMM 0600** and **BMX AMM 0600H** current range has the following characteristics.

Nominal variation range	0..20 mA/4..20 mA
Available maximum current	24 mA
Current resolution	11 bits
Measurement error:	
<ul style="list-style-type: none"> ● at 25°C (77°F) ● maximum in temperature ranges 	0.25% of FS(1) 0.60% of FS(1)
Temperature drift	100 ppm/°C
Monotonicity	Yes
Non linearity	0.1% of FS
AC output ripple	2 mV rms on 50 Ω BW < 25MHz
Load impedance	600 Ω maximum
Detection type	Open circuit (1)
Legend	
(1) The open circuit detection is physically detected by the module in range 4...20 mA. It is also detected if the target current value is different from 0 mA in range 0...20 mA.	

Response time of Outputs

The maximum delay between transmission of the output value on the PLC bus and its effective positioning on the terminal block is less than 2 ms:

- internal cycle time = 1 ms for the two outputs
- digital/analog conversion response time = 1ms maximum for a 0-100% step.

Functional Description

Function

The BMX AMM 0600 Input/Output module combines 4 non-isolated analog inputs with 2 non-isolated analog outputs. However, input and output blocks are isolated.

The BMX AMM 0600 module offers the following range, according to the selection made during configuration:

- Voltage input range $\pm 10\text{ V}/0..10\text{ V}/0..5\text{ V}/1..5\text{ V}$
- Current input range $0..20\text{ mA}/4..20\text{ mA}$
- Voltage output range $\pm 10\text{ V}$
- Current output range $0..20\text{ mA}/4..20\text{ mA}$

Illustration

The BMX AMM 0600 module's illustration is as follows.

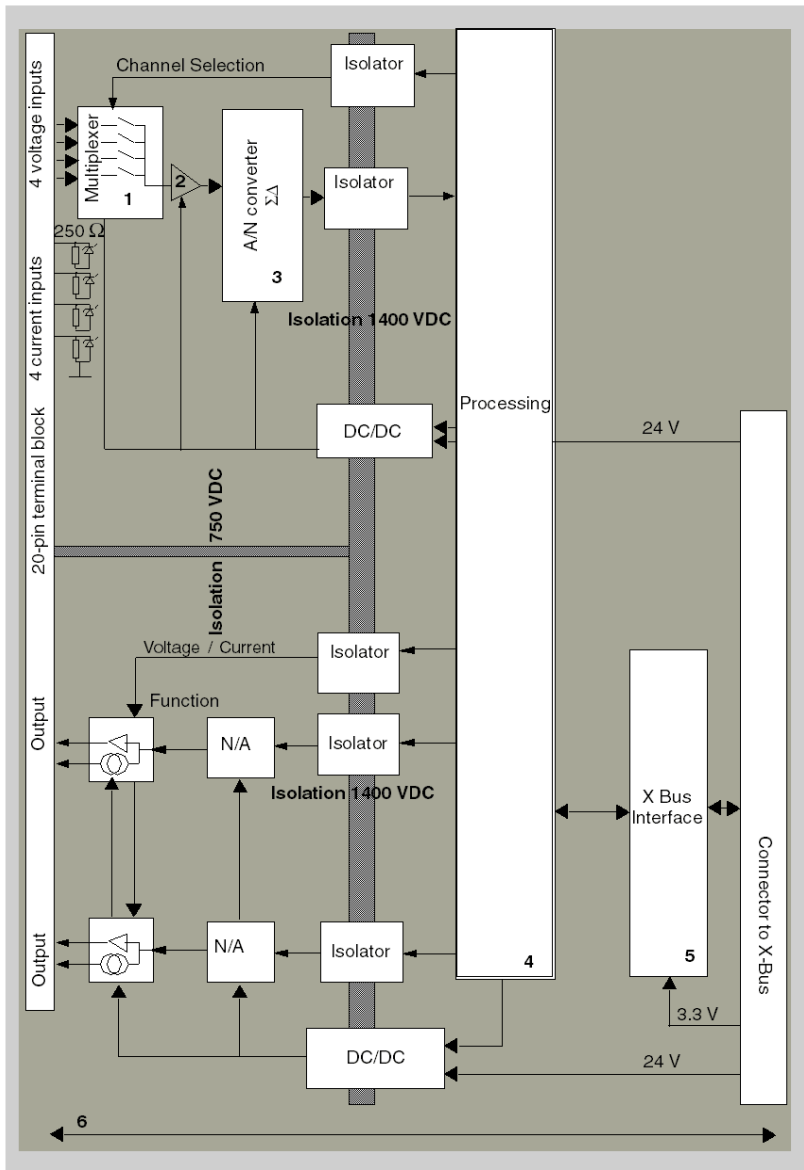

Description.

Address	Process	Characteristics
1	Adaptation	<ul style="list-style-type: none"> ● physical connection to the process through a 20-pin screw terminal block ● protecting the module against voltage spikes
2	Adapting the signal	<ul style="list-style-type: none"> ● the adaptation is performed on voltage or current via software configuration
3	Converting	<ul style="list-style-type: none"> ● this conversion is performed on 13 bits with a polarity sign ● reframing the data provided by the program is performed automatically and dynamically by the converter
4	Transforming application data into data directly usable by the digital/analog converter	<ul style="list-style-type: none"> ● use of factory calibration parameters
5	Communicating with the Application	<ul style="list-style-type: none"> ● manages exchanges with CPU ● topological addressing ● receiving, from the application, configuration parameters for the module and channels, as well as numeric set points from the channels ● sending module status back to application
6	Module monitoring and sending error notifications back to the application	<ul style="list-style-type: none"> ● testing for range overflow on channels ● testing for output open circuits or short-circuits ● watchdog test ● Programmable fallback capabilities

Input functions: Measurement Timing

The timing of measurements is determined by the cycle selected during configuration: Normal or Fast Cycle.

- Normal Cycle means that the scan cycle duration is fixed.
- With the Fast Cycle, however, the system only scans the channels designated as being In Use. The scan cycle duration is therefore proportional to the number of channels In Use.

The cycle time values are based on the cycle selected.

Module	Normal Cycle	Fast Cycle
BMX AMM 0600	5 ms	1 ms + (1 ms x N) where N: number of channels in use.

NOTE: Module cycle is not synchronized with the PLC cycle. At the beginning of each PLC cycle, each channel value is taken into account. If the MAST/FAST task cycle time is less than the module's cycle time, some values will not have changed.

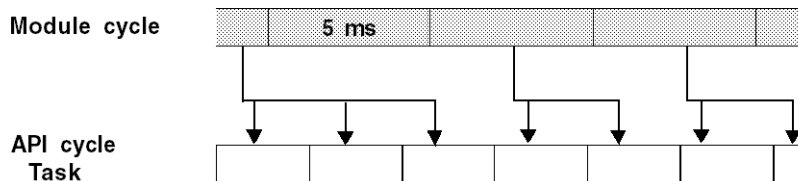

Input functions: Overflow/Underflow Control

Module BMX AMM 0600 allows the user to select between 6 voltage or current ranges for each input.

This option for each channel have to be configured in configuration windows. Upper and lower tolerance detection are always active regardless of overflow/underflow control.

Depending on the range selected, the module checks for overflow: it ensures that the measurement falls between a lower and an upper threshold.

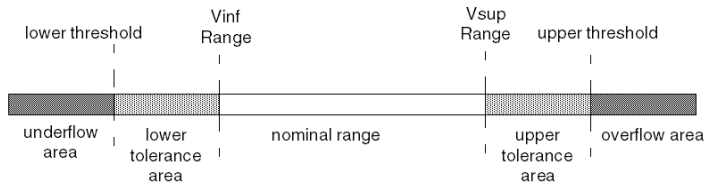

Description:

Designation	Description
Nominal range	measurement range corresponding to the chosen range
Upper Tolerance Area	varies between the values included between the maximum value for the range (for instance: +10 V for the +/-10 V range) and the upper threshold
Lower Tolerance Area	varies between the values included between the minimum value for the range (for instance: -10 V for the +/-10 V range) and the lower threshold
Overflow Area	area located beyond the upper threshold
Underflow Area	area located below the lower threshold

The values of the thresholds are configurable independently from one another. They may assume integer values between the following limits.

	Range	BMX AMM 0600 Inputs									
		Underflow Area		Lower Tolerance Area		Nominal Range		Upper Tolerance Area		Overflow Area	
Unipolar	0...10 V	-1,250	-1,001	-1,000	-1	0	10,000	10,001	11,000	11,001	11,250
	0...5 V / 0...20 mA	-5,000	-1,001	-1,000	-1	0	10,000	10,001	11,000	11,001	15,000
	1...5 V / 4...20 mA	-4,000	-801	-800	-1	0	10,000	10,001	10,800	10,801	14,000
Bipolar	+/- 10 V	-11,250	-11,001	-11,000	-10,001	-10,000	10,000	10,001	11,000	11,001	11,250
User	+/- 10 V	-32,768				User-defined	User-defined				32,767
	0...10 V	-32,768				User-defined	User-defined				32,767

Input functions: Measurement Display

Measurements may be displayed using standardized display (in %, to two decimal places).

Type of Range	Display
Unipolar range 0...10 V, 0...5 V, 1...5 V, 0...20mA, 4...20mA	from 0 to 10,000 (0 % at +100.00 %)
Bipolar range +/- 10 V, +/- 5 mV +/- 20 mA	from -10,000 to 10,000 (-100.00 % at +100.00 %)

It is also possible to define the range of values within which measurements are expressed, by selecting:

- the lower threshold corresponding to the minimum value for the range: 0 % (or -100.00 %).
- the upper threshold corresponding to the maximum value for the range (+100.00 %).

The lower and upper thresholds must be integers between -32,768 and +32,767.

For example, imagine a conditioner providing pressure data on a 4-20 mA loop, with 4 mA corresponding to 3,200 millibar and 20 mA corresponding to 9,600 millibar. You have the option of choosing the User format, by setting the following lower and upper thresholds:

3,200 for 3,200 millibar as the lower threshold

9,600 for 9,600 millibar as the upper threshold

Values transmitted to the program vary between 3,200 (= 4 mA) and 9,600 (= 20 mA).

Input functions: Measurement Filtering

The type of filtering performed by the system is called "first order filtering". The filtering coefficient can be modified from a programming console or via the program.

The mathematical formula used is as follows:

$$Mesf(n) = \alpha \times Mesf(n - 1) + (1 - \alpha) \times Valb(n)$$

where:

α = efficiency of the filter

Mesf(n) = measurement filtered at moment n

Mesf(n-1) = measurement filtered at moment n-1

Valg(n) = gross value at moment n

You may configure the filtering value from 7 possibilities (from 0 to 6). This value may be changed even when the application is in RUN mode.

NOTE: Filtering may be accessed in Normal or Fast Cycle.

The filtering values depend on the T configuration cycle (where T = cycle time of 5 ms in standard mode):

Desired Efficiency	Required Value	Corresponding α	Filter Response Time at 63%	Cut-off Frequency (in Hz)
No filtering	0	0	0	0
Low filtering	1	0.750	4 x T	0.040 / T
	2	0.875	8 x T	0.020 / T
Medium filtering	3	0.937	16 x T	0.010 / T
	4	0.969	32 x T	0.005 / T
High filtering	5	0.984	64 x T	0.0025 / T
	6	0.992	128 x T	0.0012 / T

Input functions: Sensor Alignment

The process of "alignment" consists in eliminating a systematic offset observed with a given sensor, around a specific operating point. This operation compensates for an error linked to the process. Replacing a module does not therefore require a new alignment. However, replacing the sensor or changing the sensor's operating point does require a new alignment.

Conversion lines are as follows.

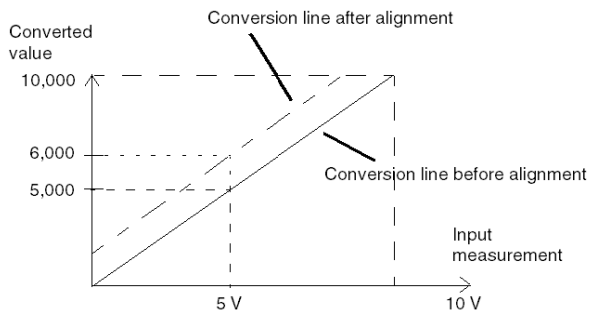

The alignment value is editable from a programming console, even if the program is in RUN Mode. For each input channel, you can:

- view and modify the desired measurement value
- save the alignment value
- determine whether the channel already has an alignment

The alignment offset may also be modified through programming.

Channel alignment is performed on the channel in standard operating mode, without any effect on the channel's operating modes.

The maximum offset between measured value and desired (aligned) value may not exceed +/- 1,500.

NOTE: To align several analog channels on the BMX AMO/AMI/AMM/ART modules, we recommend proceeding channel by channel. Test each channel after alignment before moving to the next channel to apply the parameters correctly.

Output Functions: Writing Outputs

The application must provide the outputs with values in the standardized format:

- -10,000 to +10,000 for the +/-10 V range
- 0 to +10,000 in 0-20 mV and 4-20 mA ranges

Digital/Analog Conversion

The digital/analog conversion is performed on:

- 12-bit in 0-20 mA, 4-20 mA ranges and for the +/-10 V range

Output Functions: Overflow Control

Module BMX AMM 0600 allows an overflow control on voltage and current ranges.

The measurement range is divided in three areas.

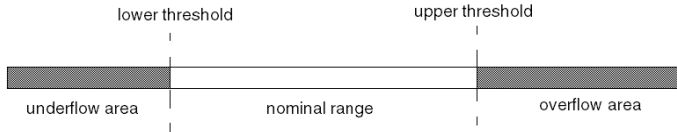

Description:

Designation	Description
Nominal range	measurement range corresponding to the chosen range
Overflow Area	area located beyond the upper threshold
Underflow Area	area located below the lower threshold

Overflow values for the various ranges are as follows.

Range	BMX AMM 0600 outputs					
	Underflow Area		Nominal Range		Overflow Area	
+/- 10V	-11,250	-11,001	-11,000	11,000	11,001	11,250
0..20mA	-2,000	-1,001	-1,000	11,000	11,001	12,000
4..20mA	-1,600	-801	-800	10,800	10,801	11,600

You may also choose the flag for an overflow of the range upper value, for an underflow of the range lower value, or for both.

NOTE: Range under/overflow detection is optional.

Output Functions: Fallback/Maintain or Reset Outputs to Zero

In case of error, and depending on its seriousness, the outputs:

- switch to Fallback/Maintain position individually or together,
- are forced to 0 (0 V or 0 mA).

Various Behaviors of Outputs.

Error	Behavior of Voltage Outputs	Behavior of Current Outputs
Task in STOP mode, or program missing	Fallback/Maintain (channel by channel)	Fallback/Maintain (channel by channel)
Communication interruption		
Configuration Error	0 V (all channels)	0 mA (all channels)
Internal Error in Module		
Output Value out-of-range (range under/overflow)	Value saturated at the defined limit (channel by channel)	Saturated value (channel by channel)
Output short circuit or open circuit	Short-circuit: Maintain (channel by channel)	Open circuit: Maintain (channel by channel)
Module Hot swapping (processor in STOP mode)	0 V (all channels)	0 mA (all channels)
Reloading Program		

Fallback or maintain at current value is selected during the module configuration. Fallback value may be modified from the Debug in Unity Pro or through a program.

⚠ WARNING
UNEXPECTED EQUIPMENT OPERATION
The fallback position should not be used as the sole safety method. If an uncontrolled position can result in a hazard, an independent redundant system must be installed.
Failure to follow these instructions can result in death, serious injury, or equipment damage.

Output Functions: Behavior at Initial Power-Up and When Switched Off.

When the module is switched on or off, the outputs are set to 0 (0 V or 0 mA).

Output Functions: Actuator Alignment

The process of "alignment" consists in eliminating a systematic offset observed with a given actuator, around a specific operating point. This operation compensates for an error linked to the process. Therefore, replacing a module does not require a new alignment. However, replacing the actuator or changing the sensor's operating point does require a new alignment.

Conversion lines are as follows:

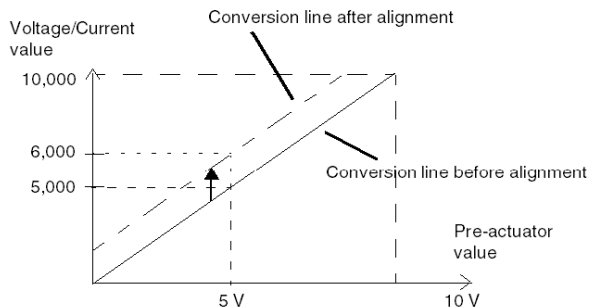

The alignment value is editable from a programming console, even if the program is in RUN Mode. For each output channel, you can:

- view and modify the initial output target value
- save the alignment value
- determine whether the channel already has an alignment

The maximum offset between the measured value and the corrected output value (aligned value) may not exceed +/- 1.500.

NOTE: to align several analog channels on the BMX AMO/AMI/AMM/ART modules, we recommend proceeding channel by channel. Test each channel after alignment before moving to the next channel to apply the parameters correctly.

Wiring Precautions

Introduction

In order to protect the signal from outside interference induced in series mode and interference in common mode, we recommend that you take the following precautions.

Cable Shielding

Connect the cable shielding to the grounding bar. Clamp the shielding to the grounding bar on the module side. Use the shielding connection kit BMXXSP**** (see page 50) to connect the shielding.

⚠ DANGER

HAZARD OF ELECTRIC SHOCK, EXPLOSION, OR ARC FLASH

While mounting / removing the modules:

- make sure that each terminal block is still connected to the shield bar and
- disconnect voltage supplying sensors and pre-actuators.

Failure to follow these instructions will result in death or serious injury.

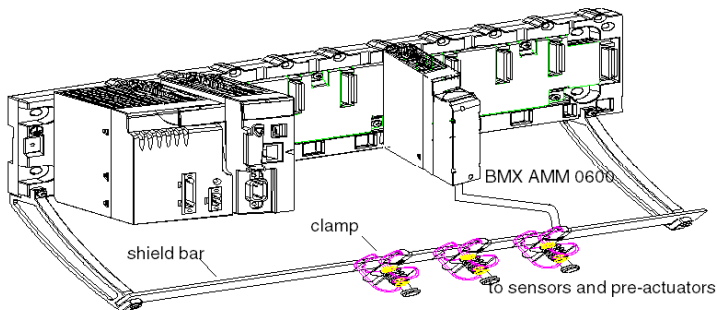

Reference of Sensors in Relation to the Ground

In order for the acquisition system to operate correctly, we recommend you take the following precautions:

- sensors must be close together (a few meters)
- all sensors must be referenced to a single point, which is connected to the PLC's ground

Using Sensors with non Isolated Inputs

The inputs of the module are not isolated between them and single ended type. They do not admit any common mode voltage. The sensors are connected as indicated in the following diagram:

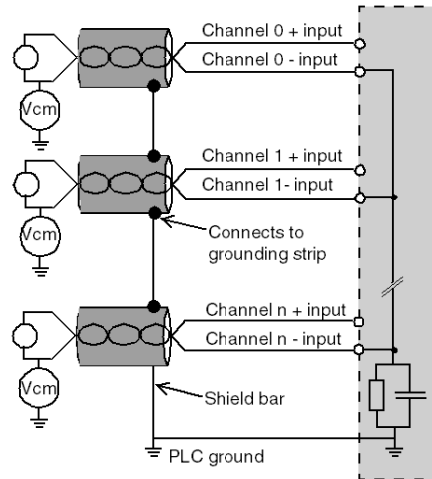

If one or more sensors are referenced in relation to the ground, this may in some cases return a remote ground current to the terminal block and disturbs the measures. It is therefore **essential** to follow the following rules:

- Use isolated from ground sensors if distance from sensors is > 30 meters or if power equipments are located near PLC.
- The potential must be less than the permitted low voltage: for example, 30 Vrms or 42.4 VDC between sensors and shield.
- Setting a sensor point to a reference potential generates a leakage current. You must therefore check that all leakage currents generated do not disturb the system.

Using Pre-Actuators Referenced in Relation to the Ground

There are no specific technical constraints for referencing pre-actuators to the ground. For safety reasons, it is nevertheless preferable to avoid returning a remote ground potential to the terminal; this may be very different to the ground potential close by.

Sensors and other peripherals may be connected to a grounding point some distance from the module. Such remote ground references may carry considerable potential differences with respect to local ground. Induced currents do not affect the measurement or integrity of the system.

DANGER

HAZARD OF ELECTRIC SHOCK

Ensure that sensors and others peripherals are not exposed through grounding points to voltage potential greater than acceptable limits.

Failure to follow these instructions will result in death or serious injury.

Electromagnetic hazards instructions

WARNING

UNEXPECTED EQUIPEMENT OPERATION

Follow those instructions to reduce electromagnetic perturbations:

- adapt the programmable filtering to the frequency applied at the inputs,
- use the shielding connection kit BMXXSP**** (*see page 50*) to connect the shielding,
- use a specific 24 VDC supply to sensors and a shielded cable for connecting the sensors to the module.

Electromagnetic perturbations may cause the application to operate in an unexpected manner.

Failure to follow these instructions can result in death, serious injury, or equipment damage.

Wiring Diagram

Introduction

The actuators are connected using the 20-point terminal block.

Illustration

The terminal block connection, the sensors, and the actuators wiring are as follows.

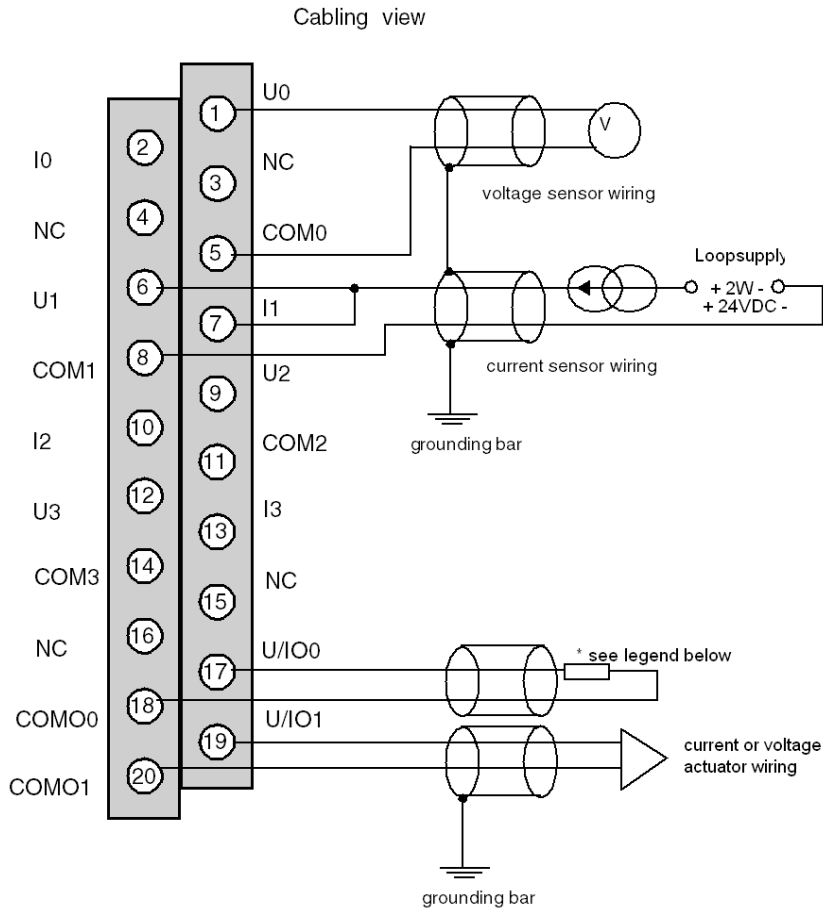

U_x + pole input for channel x

COM_x - pole input for channel x

U/IO_x : + pole output for channel x

COMO_x - pole output for channel x

* The current loop is self-powered by the output and does not request any external supply.

Part II

Software Implementation of Analog Modules

In this Part

This part sets forth general rules for implementing analog input/output modules with the Unity Pro Software program.

What Is in This Part?

This part contains the following chapters:

Chapter	Chapter Name	Page
11	General Overview of Analog Modules	217
12	Configuring Analog Modules	219
13	IODDTs and Device DDTs for Analog Modules	241
14	Analog Module Debugging	265
15	Analog Module Diagnostics	273
16	Operating Modules from the Application	279

Chapter 11

General Overview of Analog Modules

Introduction to the Installation Phase

Introduction

The software installation of application-specific modules is carried out from the various Unity Pro editors:

- in Offline mode,
- in Online mode.

If you do not have a processor to which you can connect, Unity Pro allows you to carry out an initial test using a simulator. In this case, the installation is different.

You are advised to follow the designated order of the installation phases. You may however change this order (by starting with the configuration phase, for example).

Installation Phases When Using a Processor

The following table presents the various installation phases when using a processor.

Phase	Description	Mode
Declaration of variables	declaration of IODDT-type variables for the application-specific modules and the project variables	Offline (1)
Programming	project programming	Offline (1)
Configuration	declaration of modules	Offline
	module channel configuration	
	entry of configuration parameters	
Association	association of IODDT variables with the configured channels (variable editor)	Offline (1)
Generation	project generation (analysis and editing of links)	Offline
Transfer	transfer project to PLC	Online
Adjustment/Debugging	project debugging from debug screens and animation tables	Online
	modifying the program and adjustment parameters	
Legend:		
(1) These phases may also be performed online.		

Phase	Description	Mode
Documentation	creating a documentation file and printing of the miscellaneous information relating to the project	Online (1)
Operation/Diagnostics	display of the miscellaneous information required to supervise the project	Online
	diagnostics of the project and modules	
Legend:		
(1) These phases may also be performed online.		

Installation Phases When Using a Simulator

The following table presents the various installation phases when using a simulator.

Phase	Description	Mode
Declaration of variables	declaration of IODDT-type variables for the application-specific modules and the project variables	Offline (1)
Programming	project programming	Offline (1)
Configuration	declaration of modules	Offline
	module channel configuration	
	entry of configuration parameters	
Association	association of IODDT variables with the configured modules (variable editor)	Offline (1)
Generation	project generation (analysis and editing of links)	Offline
Transfer	transfer project to simulator	Online
Simulation	program simulation without inputs/outputs	Online
Adjustment/Debugging	project debugging from debug screens and animation tables	Online
	modifying the program and adjustment parameters	
Legend:		
(1) These phases may also be performed online.		

Configuration of Modules

The configuration parameters may only be modified from the Unity Pro software.

Adjustment parameters may be modified either from the Unity Pro software (in debugging mode) or from the application.

Chapter 12

Configuring Analog Modules

Subject of this Chapter

This chapter covers the configuration of a module with analog inputs and outputs.

What Is in This Chapter?

This chapter contains the following sections:

Section	Topic	Page
12.1	Configuring Analog Modules: Overview	220
12.2	Parameters for Analog Input/Output Channels	222
12.3	Entering Configuration Parameters Using Unity Pro	227

Section 12.1

Configuring Analog Modules: Overview

Description of the Configuration Screen of an Analog Module

Configuration Screen

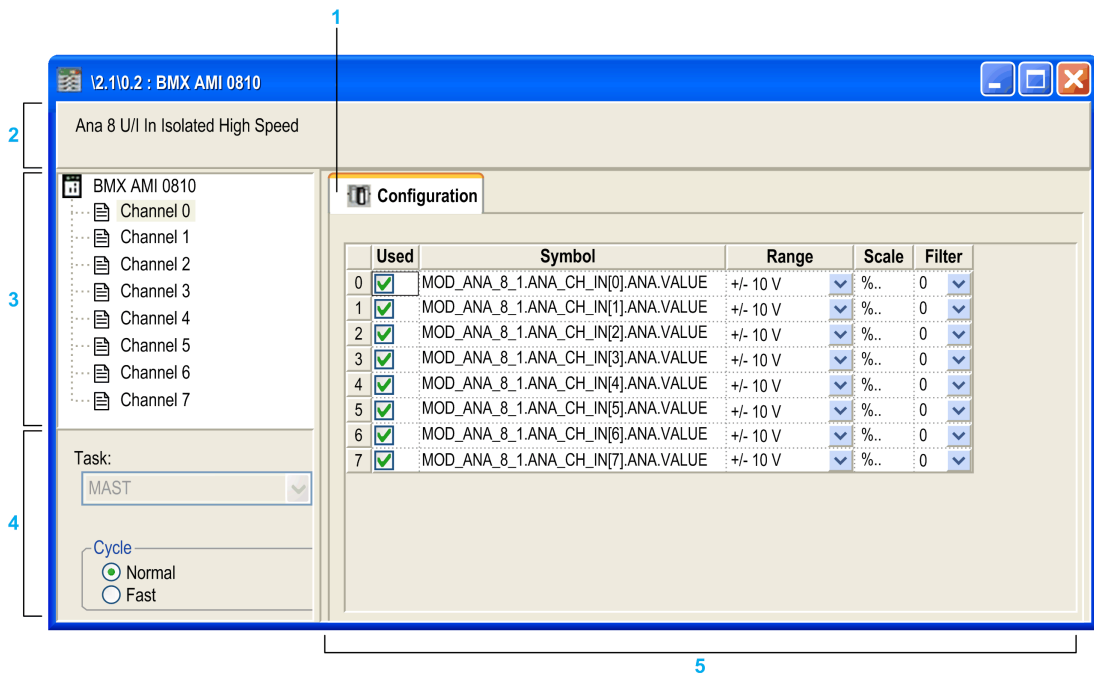

Module Configuration Window

The following table presents the various parts of the above screen:

Number	Element	Function
1	Tabs	The tab in the foreground indicates the mode in progress (Configuration of the Channels in this example).
2	Heading	Displays the abbreviated module indicator. In the same area there are 3 LEDs which indicate the status of the module in online mode: <ul style="list-style-type: none"> ● RUN indicates the operating status of the module. ● ERR signals a detected error within the module. ● I/O indicates an event from outside the module or an application error.
3	Module selection	Allows you, by clicking on the module reference number, to display: <ul style="list-style-type: none"> ● The Overview tab which gives the characteristics of the device. ● The I/O Objects tab or Device DDT tab depending on the I/O data type selected at module insertion or required. These tabs are used to presymbolize the input/output objects. ● The Fault which shows the device status (in online mode).
	Channel selection	Allows you, by clicking on the channel number, to display: <ul style="list-style-type: none"> ● The Configuration tab that enables to configure each channel. ● The Debug which shows the channel status (in online mode).
4	General parameters area	This is used to set up the channels using several fields: <ul style="list-style-type: none"> ● Task: defines task through which the exchanges between the processor and the module will be carried out. ● Cycle: allows you to define the scan cycle for inputs (only available on some analog modules). ● Rejection: at 50 Hz or 60 Hz (only available on some analog modules). ● Cold junction Ch 0-3: allows you to define the cold junction compensation according to the hardware used for channels 0 to 3 (only available on some analog modules).
5	Configuration area	This is used to define the configuration parameters of the different channels. This area includes several topics, whose display varies depending on the analog module you've selected. The Symbol column displays the symbol associated with the channel once it's been defined by the user (from the Variables Editor).

Section 12.2

Parameters for Analog Input/Output Channels

Subject of this Section

This section describes the various input/output channel parameters for an analog module.

What Is in This Section?

This section contains the following topics:

Topic	Page
Parameters for Analog Input Modules	223
Parameters for Analog Output Modules	226

Parameters for Analog Input Modules

At a Glance

Analog input modules include channel-specific parameters displayed in the module configuration screen.

Reference

The available parameters for each analog input module are as follows (parameters indicated in bold characters are part of the default configuration).

Parameter	BMX AMI 0410	BMX AMI 0800	BMX AMI 0810
Number of input channels	4	8	8
Channel used ⁽¹⁾	Active / Inactive	Active / Inactive	Active / Inactive
Scan Cycle	Normal Fast	Normal Fast	Normal Fast
Range	+/-10 V 0..0.10 V 0..5 V / 0..20 mA 1..5 V / 4..20 mA +/- 5V +/- 20mA	+/-10 V 0..10 V 0..5 V / 0..20 mA 1..5 V / 4..20 mA +/- 5V +/- 20mA	+/-10 V 0..10 V 0..5 V / 0..20 mA 1..5 V / 4..20 mA +/- 5V +/- 20mA
Filter	0.6	0.6	0.6
Display	%.. / User	%.. / User	%.. / User
Task associated to Channel	MAST / FAST	MAST / FAST	MAST / FAST
Group of channels affected by the task change	2 contiguous channels	2 contiguous channels	2 contiguous channels
Rejection	-	-	-
Wiring Control ⁽¹⁾	-	-	-
Cold junction compensation: channels 0-3	N/A	N/A	N/A
Lower Range Overflow Control ⁽¹⁾	Active / Inactive	Active / Inactive	Active / Inactive
Upper Range Overflow Control ⁽¹⁾	Active / Inactive	Active / Inactive	Active / Inactive
Lower Threshold Range Overflow ⁽¹⁾	-11,400	-11,400	-11,400
Upper Threshold Range Overflow ⁽¹⁾	11,400	11,400	11,400
(1) This parameter is available as a checkbox.			

Parameter	BMX AMM 0600	BMX ART 0414	BMX ART 0814
Number of input channels	4	4	8
Channel used ⁽¹⁾	Active / Inactive	Active / Inactive	Active / Inactive
Scan Cycle	Normal Fast	-	-
Range	+/-10 V 0..0.10 V 0..5 V / 0..20 mA 1..5 V / 4..20 mA	Thermo K Thermocouple B Thermocouple E Thermo J Thermo L Thermo N Thermo R Thermo S Thermo T Thermo U 0..400 Ohms 0..4000 Ohms Pt100 IEC/DIN Pt1000 IEC/DIN Pt100 US/JIS Pt1000 US/JIS Cu10 Copper Ni100 IEC/DIN Ni1000 IEC/DIN +/- 40 mV +/- 80 mV +/- 160 mV +/- 320 mV +/- 640 mV +/- 1.28 V	Thermo K Thermocouple B Thermocouple E Thermo J Thermo L Thermo N Thermo R Thermo S Thermo T Thermo U 0..400 Ohms 0..4000 Ohms Pt100 IEC/DIN Pt1000 IEC/DIN Pt100 US/JIS Pt1000 US/JIS Cu10 Copper Ni100 IEC/DIN Ni1000 IEC/DIN +/- 40 mV +/- 80 mV +/- 160 mV +/- 320 mV +/- 640 mV +/- 1.28 V
Filter	0..6	0..6	0..6
Display	%.. / User	1/10 °C / 1/10 °F / %.. / User	1/10 °C / 1/10 °F / %.. / User
Task associated to Channel	MAST / FAST	MAST	MAST
Group of channels affected by the task change	2 contiguous channels	2 contiguous channels	2 contiguous channels
Rejection	-	50 Hz / 60 Hz	50 Hz / 60 Hz
Wiring Control ⁽¹⁾	-	Active / Inactive	Active / Inactive
(1) This parameter is available as a checkbox.			

Parameter	BMX AMM 0600	BMX ART 0414	BMX ART 0814
Cold junction compensation: channels 0-3	N/A	<ul style="list-style-type: none"> ● Internal by TELEFAST, ● External by PT100. 	<ul style="list-style-type: none"> ● Internal by TELEFAST, ● External by PT100, ● Using the CJC values of channels 4/7 for channels 0/3.
Lower Range Overflow Control ⁽¹⁾	Active / Inactive	Active / Inactive	Active / Inactive
Upper Range Overflow Control ⁽¹⁾	Active / Inactive	Active / Inactive	Active / Inactive
Lower Threshold Range Overflow ⁽¹⁾	-11,250	-2,680	-2,680
Upper Threshold Range Overflow ⁽¹⁾	11,250	13,680	13,680
(1) This parameter is available as a checkbox.			

Parameters for Analog Output Modules

At a Glance

The analog output module includes channel-specific parameters displayed in the module configuration screen.

Reference

The following table shows the available parameters (parameters indicated in bold characters are part of the default configuration).

Module	BMX AMO 0210	BMX AMO 0410	BMX AMO 0802	BMX AMM 0600
Number of output channels	2	4	8	2
Range	+/-10 V 0...20 mA 4...20 mA	+/-10 V 0...20 mA 4...20 mA	0...20 mA 4...20 mA	+/-10 V 0...20 mA 4...20 mA
Task associated to Channel	MAST / FAST	MAST / FAST	MAST / FAST	MAST / FAST
Group of channels affected by the task change	All channels	All channels	All channels	All channels
Fallback	Fallback to 0 / Maintain / Fallback to value	Fallback to 0 / Maintain / Fallback to value	Fallback to 0 / Maintain / Fallback to value	Fallback to 0 / Maintain / Fallback to value
Lower Range Overflow Control ⁽¹⁾	Active / Inactive	Active / Inactive	Active / Inactive	Active / Inactive
Upper Range Overflow Control ⁽¹⁾	Active / Inactive	Active / Inactive	Active / Inactive	Active / Inactive
Wiring check ⁽¹⁾	Active / Inactive	Active / Inactive	Active / Inactive	Active / Inactive
(1) This parameter is available as a checkbox.				

Section 12.3

Entering Configuration Parameters Using Unity Pro

Subject of this Section

This section presents the entry of various configuration parameters for analog input/output channels using Unity Pro.

NOTE: For the communication between the channels and the CPU there is the logical nodes. Each logical node includes two channels. So when you modify the configuration of analog modules, the new parameters are applied for both channels of the logical node, Unity messages will inform you of this modification.

What Is in This Section?

This section contains the following topics:

Topic	Page
Selecting the Range for an Analog Module's Input or Output	228
Selecting a Task Associated to an Analog Channel	229
Selecting the Input Channel Scan Cycle	230
Selecting the Display Format for a Current or Voltage Input Channel	231
Selecting the Display Format for a Thermocouple or RTD Input Channel	233
Selecting the Input Channels' Filter Value	234
Selecting Input Channel Usage	235
Selecting the Overflow Control Function	236
Selecting the Cold Junction Compensation	238
Selecting the Fallback Mode for Analog Outputs	239

Selecting the Range for an Analog Module's Input or Output

At a Glance

This parameter defines the range for the input or output channel.

Depending on the type of module, the input/output range may be:

- voltage
- current
- a thermocouple
- a RTD

Procedure

The procedure to define the range assigned to an analog module's channels is as follows.

Step	Procedure
1	Access the hardware configuration screen for the appropriate module
2	In the range column, click on the arrow of the pull-down menu pertaining to the channel you wish to configure Results : The following list appears. 
3	Select the appropriate range
4	Validate the change by clicking Edit → Validate

Selecting a Task Associated to an Analog Channel

At a Glance

This parameter defines the task through which the acquisition of inputs and the update of outputs are performed.

Depending on the type of module, the task is defined for a series of 2 or 4 contiguous channels.

The possible choices are as follows:

- the **MAST** task
- the **FAST** task

NOTE: The BMX ART 0414/0814 modules run only in Mast task.

WARNING

UNEXPECTED EQUIPMENT OPERATION

Do not assign more than 2 analog modules to the **FAST** task (each with all four channels in use). Using more than 2 modules may trigger system timing conflicts.

Failure to follow these instructions can result in death, serious injury, or equipment damage.

Procedure

The procedure to define the type of task assigned to an analog module's channels is as follows:

Step	Action
1	Access the hardware configuration screen for the appropriate module.
2	For the individual channel or group of channels you wish to configure, click on the Task pull-down menu in the General Parameters area. Result: The following scrolldown list appears: 
3	Select the appropriate task.
4	Validate the change by clicking Edit → Validate .

Selecting the Input Channel Scan Cycle

At a Glance

This parameter defines the input channel scan cycle for analog modules.

The input scan cycle may be:

- **Normal:** Channels are sampled within the time period specified in the module's characteristics.
- **Fast:** Only those inputs declared to be **In Use** are sampled. The scan cycle is therefore determined by the number of channels in use and by the time period allocated for scanning one channel.

Input channel registers are updated at the beginning of the task to which the module is assigned.

NOTE: The **Normal / Fast** and **In Use** cycle parameters cannot be edited in online mode if the project has been transferred to the PLC with the default values specified for these parameters (i.e. Normal cycle and All channels in use).

Instructions

The following table provides step-by-step instructions allowing you to define the scan cycle assigned to an analog module's inputs.

Step	Action
1	Access the hardware configuration screen for the appropriate module.
2	For the group of input channels you wish to configure, check the appropriate box (Normal or Fast) for the Cycle field of the General Parameters area. Result: The selected scan cycle will be assigned to the channels.
3	Validate the change by clicking Edit → Validate .

Selecting the Display Format for a Current or Voltage Input Channel

At a Glance

This parameter defines the display format for the measurement of an analog module channel whose range is configured for voltage or current.

The display format may be:

- standardized (%..):
 - unipolar range: 0 to +10,000
 - bipolar range : -10,000 to +10,000
- user-defined (**User**).

Procedure

The following table provides step-by-step instructions defining the display scale assigned to an analog module channel.

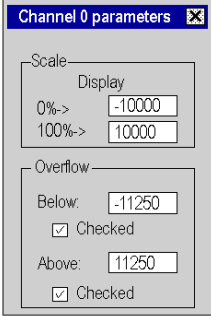
Step	Action
1	Access the hardware configuration screen for the appropriate module.
2	Click in the cell of the Scale column for the channel you wish to configure. Result: an arrow appears.
3	Click on the arrow in the cell of the Scale column for the channel you wish to configure. Result : The Channel Parameters dialog box appears.  Note: The display modification change only concerns the Scale area. The Overflow area enables the modification of the overflow control (<i>see page 236</i>).
4	Type in the values to be assigned to the channel in the two Display boxes situated in the Scale zone.

Step	Action
5	Confirm your changes by closing the dialog box Note: If default values have been selected (standardized display), the corresponding cell in the Scale column displays %... Otherwise it will show User (user display).
6	Validate the change by clicking Edit → Validate .

Selecting the Display Format for a Thermocouple or RTD Input Channel

At a Glance

This parameter defines the display format for the measurement of an analog module channel whose range is configured as Thermocouple or RTD .

The available display formats are degrees Celsius (centigrade) or Fahrenheit, with the possibility of short-circuit or open circuit notification.

Procedure

The procedure for defining the display scale assigned to an analog module channel whose range is configured as a Thermocouple or RTD is as follows:

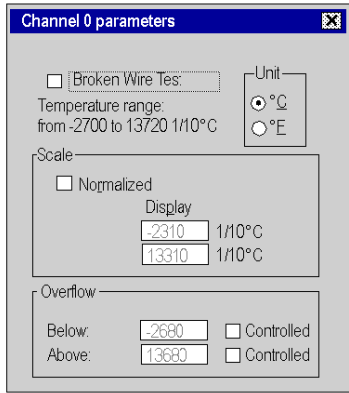
Step	Action
1	Access the hardware configuration screen for the appropriate module.
2	Click in the cell of the Scale column for the channel you wish to configure. Result: an arrow appears.
3	Click on the arrow in the cell of the Scale column for the channel you wish to configure. Results : The Channel Parameters dialog box appears.
	
4	Check the Broken Wire Test box is you want to activate this function.
5	Select the temperature unit by checking °C or °F .
6	Check the Standardized box for a standardized display.
7	Validate the choice by closing the dialog box.
8	Validate the change by clicking Edit → Validate .

Selecting the Input Channels' Filter Value

At a Glance

This parameter defines the type of filtering for the input channel selected for analog modules (see *Measurement Filtering, page 69*).

The available filtering values are:

- **0**: No filtering
- **1** and **2**: Low filtering
- **3** and **4**: Medium filtering
- **5** and **6**: High filtering

NOTE: Filtering is taken into account in both fast scan and normal cycles.

Procedure

The following table provides instructions for defining the filter value assigned to input channels for analog modules.

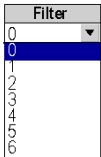
Step	Action
1	Access the hardware configuration screen for the appropriate module.
2	In the Filter column, click on the arrow of the pull-down menu pertaining to the channel you wish to configure. Results: the pulldown menu appears. 
3	Select the filter value you wish to assign to the selected channel.
4	Validate the change by clicking Edit → Validate .

Selecting Input Channel Usage

At a Glance

A channel is declared to be "In Use" in a task when the measured values are "sent back" to the task assigned to the channel in question.

If a channel is not in use, the corresponding line is grayed out, the 0 value is sent back to the application program, and status indications specified for this channel (range overflow, etc.) are inactive.

Instructions

The following table provides specific instructions for modifying the usage status of a channel.

Step	Action
1	Access the hardware configuration screen for the appropriate module.
2	Click in the cell of the In Use column for the channel you wish to modify, then select or deselect the channel.
3	Validate the change by clicking Edit → Validate .

Selecting the Overflow Control Function

At a Glance

Overflow Control is defined by a monitored or unmonitored lower threshold, and by a monitored or unmonitored upper threshold.

Procedure

The procedure for modifying the Overflow Control parameters assigned to an analog module channel is as follows.

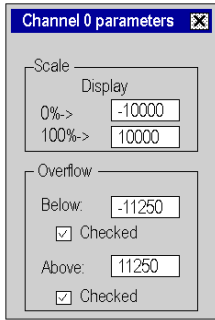
Step	Action
1	Access the hardware configuration screen for the appropriate module.
2	Click in the cell of the Scale column for the channel you wish to configure. Result: an arrow appears.
3	Click on the arrow in the cell of the Scale column for the channel you wish to configure. Results : The Channel Parameters dialog box appears. 
4	Check the Checked box of the Underflow field to specify an underflow threshold.
5	Check the Checked box of the Overflow field to specify an overflow threshold.
6	Confirm your changes by closing the dialog box
7	Validate the change by clicking Edit → Validate .

Overflow Flags

If under/overflow control is required, indications are provided by the following bits.

Bit Name	Flag (when = 1)
%IW.r.m.c.1.5	The value being read falls within the Lower Tolerance Area.
%IW.r.m.c.1.6	The value being read falls within the Upper Tolerance Area.
%IW.r.m.c.2.1	If over/underflow control is required, this bit indicates that the value currently read falls within one of the two unauthorized ranges: <ul style="list-style-type: none">● %MW.r.m.c.3.6 denotes an underflow● %MW.r.m.c.3.7 denotes an overflow
%Ir.m.c.ERR	Channel Error.

Selecting the Cold Junction Compensation

At a Glance

This function is available on the BMX ART 0414/814 analog input modules. It is carried out either by TELEFAST or by a Pt100 probe. An internal compensation by TELEFAST is proposed by default.

BMX ART 0414/0814 Module

The procedure for modifying the cold junction compensation of the BMX ART 0414/814 modules is as follows.

Step	Action
1	Access the hardware configuration screen for the appropriate module.
2	Check the Internal by TELEFAST, the External by Pt100 or the Temperature from Ch4-7 bloc box in the Cold Junction Channel 0-3 field.
3	Validate the change with Edit → Validate .

	Used	Symbol	Range	Scale	Filter
0	<input checked="" type="checkbox"/>		Thermo K	1/10 C.	0
1	<input checked="" type="checkbox"/>		Thermo K	1/10 C.	0
2	<input checked="" type="checkbox"/>		Thermo K	1/10 C.	0
3	<input checked="" type="checkbox"/>		Thermo K	1/10 C.	0
4	<input checked="" type="checkbox"/>		Thermo K	1/10 C.	0
5	<input checked="" type="checkbox"/>		Thermo K	1/10 C.	0
6	<input checked="" type="checkbox"/>		Thermo K	1/10 C.	0
7	<input checked="" type="checkbox"/>		Thermo K	1/10 C.	0

Selecting the Fallback Mode for Analog Outputs

At a Glance

This parameter defines the behavior adopted by outputs when the PLC switches to STOP or when there is a communication error.

The possible behavior types are:

- **Fallback:** Outputs are set to an editable value between -10,000 and +10,000 (0 is the default).
- **Maintain value:** Outputs remain in the state they were in before the PLC switched to STOP.

Instructions

The following table provides instructions for defining the fallback behavior assigned to outputs of analog modules.

Step	Action
1	Access the hardware configuration screen for the appropriate module.
2	Check the box in the cell of the Fallback column for the output you want to configure.
3	Enter the desired value in the cell of the Fallback Value column. Result: The selected fallback mode will be assigned to the selected output.
4	To select the Maintain mode instead, uncheck the box in the cell of the Fallback column for the channel in question. Result: The maintain value behavior will be assigned to the selected output.
5	Validate the change by clicking Edit → Validate .

Chapter 13

IODDTs and Device DDTs for Analog Modules

Subject of this Chapter

This chapter presents the various language objects, IODDTs and Device DDTs associated with analog input/output modules.

In order to avoid several simultaneous explicit exchanges for the same channel, it is necessary to test the value of the word EXCH_STS (%MWr.m.c.0) of the IODDT associated to the channel before to call any EF using this channel.

What Is in This Chapter?

This chapter contains the following topics:

Topic	Page
Detailed Description of T_ANA_IN_BMX-type IODDT Objects	242
Detailed Description of T_ANA_IN_T_BMX-type IODDT Objects	245
Detailed Description of T_ANA_OUT_BMX-type IODDT Objects	248
Detailed Description of T_ANA_IN_GEN-type IODDT Objects	251
Detailed Description of T_ANA_OUT_GEN-type IODDT Objects	252
Details of the Language Objects of the IODDT of Type T_GEN_MOD	253
Analog Device DDT	254
MOD_FLT Byte Description	261
Analog Device Ethernet Remote I/O Forcing Mode	262

Detailed Description of T_ANA_IN_BMX-type IODDT Objects

At a Glance

The following tables describe the T_ANA_IN_BMX-type IODDT objects applicable to **BME AHI 0812, BMX AMI 0410, BMX AMI 0800, and BMX AMI 0810**, and to **the inputs of the BMX AMM 600 mixed module**.

Input Measurement

The analog input measurement object is as follows.

Standard symbol	Type	Access	Meaning	Address
VALUE	INT	R	Analog input measurement.	%IW.r.m.c.0

%I.r.m.c.ERR error bit

The %I.r.m.c.ERR error bit is as follows.

Standard symbol	Type	Access	Meaning	Address
CH_ERROR	BOOL	R	Detected error bit for analog channel.	%I.r.m.c.ERR

MEASURE_STS Measurement Status Word

The meaning of the MEASURE_STS (%IW.r.m.c.1) measurement status word bits is as follows.

Standard symbol	Type	Access	Meaning	Address
CH_ALIGNED	BOOL	R	Aligned channel.	%IW.r.m.c.1.0
CH_FORCED	BOOL	R	Forced channel.	%IW.r.m.c.1.1
LOWER_LIMIT	BOOL	R	Measurement within lower tolerance area.	%IW.r.m.c.1.5
UPPER_LIMIT	BOOL	R	Measurement within upper tolerance area.	%IW.r.m.c.1.6
INT_OFFSET_ERROR	BOOL	R	Internal offset detected error.	%IW.r.m.c.1.8
INT_REF_ERROR	BOOL	R	Internal reference detected error.	%IW.r.m.c.1.10
POWER_SUP_ERROR	BOOL	R	Not used.	%IW.r.m.c.1.11
SPI_COM_ERROR	BOOL	R	SPI communication detected error.	%IW.r.m.c.1.12

Explicit Exchange Execution Flag: EXCH_STS

The meaning of the exchange control bits of the channel EXCH_STS (%MWr.m.c.0) is as follows.

Standard symbol	Type	Access	Meaning	Address
STS_IN_PROGR	BOOL	R	Read channel status words in progress.	%MWr.m.c.0.0
CMD_IN_PROGR	BOOL	R	Command parameter exchange in progress.	%MWr.m.c.0.1
ADJ_IN_PROGR	BOOL	R	Adjustment parameter exchange in progress.	%MWr.m.c.0.2

Explicit Exchange Report: EXCH_RPT

The meaning of the EXCH_RPT (%MWr.m.c.1) report bits is as follows.

Standard symbol	Type	Access	Meaning	Address
STS_ERR	BOOL	R	Read error detected for channel status words.	%MWr.m.c.1.0
CMD_ERR	BOOL	R	Error detected during command parameter exchange.	%MWr.m.c.1.1
ADJ_ERR	BOOL	R	Error detected while exchanging adjustment parameters.	%MWr.m.c.1.2
RECONF_ERR	BOOL	R	Error detected while reconfiguring the channel.	%MWr.m.c.1.15

Standard Channel Status: CH_FLT

The following table explains the meaning of the CH_FLT (%MWr.m.c.2) status word bits. Reading is performed by a READ_STS (IODDT_VAR1).

Standard symbol	Type	Access	Meaning	Address
SENSOR_FLT	BOOL	R	Sensor connection detected error.	%MWr.m.c.2.0
RANGE_FLT	BOOL	R	Range under/overflow detected error.	%MWr.m.c.2.1
CH_ERR_RPT	BOOL	R	Channel detected error report.	%MWr.m.c.2.2
INTERNAL_FLT	BOOL	R	Inoperative channel.	%MWr.m.c.2.4
CONF_FLT	BOOL	R	Different hardware and software configurations.	%MWr.m.c.2.5
COM_FLT	BOOL	R	Problem detected communicating with the PLC.	%MWr.m.c.2.6
APPLI_FLT	BOOL	R	Application error detected (adjustment or configuration error).	%MWr.m.c.2.7
NOT_READY	BOOL	R	Channel not ready.	%MWr.m.c.3.0
CALIB_FLT	BOOL	R	Calibration detected error.	%MWr.m.c.3.2
INT_OFFS_FLT	BOOL	R	Internal calibration offset detected error.	%MWr.m.c.3.3
INT_REF_FLT	BOOL	R	Internal calibration reference detected error.	%MWr.m.c.3.4
INT_SPI_PS_FLT	BOOL	R	Internal serial link or power supply detected error.	%MWr.m.c.3.5
RANGE_UNF	BOOL	R	Recalibrated channel or range underflow.	%MWr.m.c.3.6
RANGE_OVF	BOOL	R	Aligned channel or range overflow.	%MWr.m.c.3.7

Command Controls

The following table explains the meaning of the COMMAND_ORDER (%MWr.m.c.4) status word bit. Reading is performed by a READ_STS:

Standard symbol	Type	Access	Meaning	Address
FORCING_ORDER	BOOL	R/W	Forcing/unforcing command.	%MWr.m.c.4.13

Parameters

The following table presents the meaning of the %MWr.m.c.5, %MWr.m.c.8 and %MWr.m.c.9 words. Queries used are those associated with parameters (READ_PARAM, WRITE_PARAM):

Standard symbol	Type	Access	Meaning	Address
CMD_FORCING_VALUE	INT	R/W	Forcing value to be applied.	%MWr.m.c.5
FILTER_COEFF	INT	R/W	Value of filter coefficient.	%MWr.m.c.8
ALIGNMENT_OFFSET	INT	R/W	Alignment offset value. NOTE: Offset=Target value - Measured value, for instance, if you want to see a value of 3000 when the measured value is 2400 you have to set an offset of 600.	%MWr.m.c.9
THRESHOLD0	INT	None	Reserved for evolution.	%MWr.m.c.10
THRESHOLD1	INT	None	Reserved for evolution.	%MWr.m.c.11

NOTE: In order to force a channel, you have to use the WRITE_CMD (%MWr.m.c.5) instruction and set the %MWr.m.c.4.13 bit to 1.

NOTE: To unforce a channel and use it normally, you have to set the %MWr.m.c.4.13 bit to 0.

Detailed Description of T_ANA_IN_T_BMX-type IODDT Objects

At a Glance

The following tables describe the T_ANA_IN_T_BMX-type IODDT objects applicable to **BMX ART 0414/0814** analog input modules.

Input Measurement

The analog input measurement object is as follows:

Standard symbol	Type	Access	Meaning	Address
VALUE	INT	R	Analog input measurement.	%IW.r.m.c.0

%I.r.m.c.ERR error bit

The %I.r.m.c.ERR error bit is as follows:

Standard symbol	Type	Access	Meaning	Address
CH_ERROR	BOOL	R	Error bit for analog channel.	%I.r.m.c.ERR

MEASURE_STS Measurement Status Word

The various meanings of the MEASURE_STS (%IW.r.m.c.1) measurement status word bits are as follows:

Standard symbol	Type	Access	Meaning	Address
CH_ALIGNED	BOOL	R	Aligned channel.	%IW.r.m.c.1.0
CH_FORCED	BOOL	R	Forced channel.	%IW.r.m.c.1.1
LOWER_LIMIT	BOOL	R	Measurement within lower tolerance area.	%IW.r.m.c.1.5
UPPER_LIMIT	BOOL	R	Measurement within upper tolerance area.	%IW.r.m.c.1.6
INT_OFFSET_ERROR	BOOL	R	Internal offset error.	%IW.r.m.c.1.8
INT_REF_ERROR	BOOL	R	Internal reference error.	%IW.r.m.c.1.10
POWER_SUP_ERROR	BOOL	R	Not used.	%IW.r.m.c.1.11
SPI_COM_ERROR	BOOL	R	SPI communication error.	%IW.r.m.c.1.12

Cold Junction Compensation

The value of the cold junction compensation is as follows:

Standard symbol	Type	Access	Meaning	Address
CJC_VALUE	INT	R	Cold junction compensation value (1/10°C).	%IW.r.m.c.2

Explicit Exchange Execution Flag: EXCH_STS

The meaning of the exchange control bits of the channel `EXCH_STS` (%MWr.m.c.0) is as follows:

Standard symbol	Type	Access	Meaning	Address
STS_IN_PROGR	BOOL	R	Read channel status words in progress.	%MWr.m.c.0.0
CMD_IN_PROGR	BOOL	R	Command parameter exchange in progress.	%MWr.m.c.0.1
ADJ_IN_PROGR	BOOL	R	Adjustment parameter exchange in progress.	%MWr.m.c.0.2

Explicit Exchange Report: EXCH_RPT

The meaning of the `EXCH_RPT` (%MWr.m.c.1) report bits is as follows:

Standard symbol	Type	Access	Meaning	Address
STS_ERR	BOOL	R	Read error for channel status words.	%MWr.m.c.1.0
CMD_ERR	BOOL	R	Error during command parameter exchange.	%MWr.m.c.1.1
ADJ_ERR	BOOL	R	Error while exchanging adjustment parameters.	%MWr.m.c.1.2
RECONF_ERR	BOOL	R	Error while reconfiguring the channel.	%MWr.m.c.1.15

Standard Channel Status: CH_FLT

The following table explains the meaning of the `CH_FLT` (%MWr.m.c.2) status word bits. Reading is performed by a `READ_STS` (IODDT_VAR1).

Standard symbol	Type	Access	Meaning	Address
SENSOR_FLT	BOOL	R	Sensor connection error.	%MWr.m.c.2.0
RANGE_FLT	BOOL	R	Range under/overflow error.	%MWr.m.c.2.1
CH_ERR_RPT	BOOL	R	Channel error report.	%MWr.m.c.2.2
INTERNAL_FLT	BOOL	R	Inoperative channel.	%MWr.m.c.2.4
CONF_FLT	BOOL	R	Different hardware and software configurations.	%MWr.m.c.2.5
COM_FLT	BOOL	R	Problem communicating with the PLC.	%MWr.m.c.2.6
APPLI_FLT	BOOL	R	Application error (adjustment or configuration error).	%MWr.m.c.2.7
NOT_READY	BOOL	R	Channel not ready.	%MWr.m.c.3.0
COLD_JUNCTION_FLT	BOOL	R	Cold junction compensation error.	%MWr.m.c.3.1
CALIB_FLT	BOOL	R	Calibration error.	%MWr.m.c.3.2
INT_OFFS_FLT	BOOL	R	Internal calibration offset error.	%MWr.m.c.3.3
INT_REF_FLT	BOOL	R	Internal calibration reference error.	%MWr.m.c.3.4
INT_SPI_PS_FLT	BOOL	R	Internal serial link or power supply error.	%MWr.m.c.3.5
RANGE_UNF	BOOL	R	Range underflow.	%MWr.m.c.3.6
RANGE_OVF	BOOL	R	Range overflow.	%MWr.m.c.3.7

Command Controls

The following table explains the meaning of the `COMMAND_ORDER` (%MWr.m.c.4) status word bit. Reading is performed by a `READ_STS`:

Standard symbol	Type	Access	Meaning	Address
<code>FORCING_UNFORCING_ORDER</code>	BOOL	R/W	Forcing/unforcing command.	%MWr.m.c.4.13

Parameters

The table below presents the meaning of the %MWr.m.c.5, %MWr.m.c.8 and %MWr.m.c.9 status words. Queries used are those associated with parameters (`READ_PARAM`, `WRITE_PARAM`).

Standard symbol	Type	Access	Meaning	Address
<code>CMD_FORCING_VALUE</code>	INT	R/W	Forcing value to be applied.	%MWr.m.c.5
<code>FILTER_COEFF</code>	INT	R/W	Value of filter coefficient.	%MWr.m.c.8
<code>ALIGNMENT_OFFSET</code>	INT	R/W	Alignment offset value. NOTE: Offset=Target value - Measured value, for instance, if you want to see a value of 3000 when the measured value is 2400 you have to set an offset of 600.	%MWr.m.c.9

NOTE: In order to force a channel, you have to use the `WRITE_CMD` (%MWr.m.c.5) instruction and set the %MWr.m.c.4.13 bit to 1.

NOTE: To unforce a channel and use it normally, you have to set the %MWr.m.c.4.13 bit to 0.

Detailed Description of T_ANA_OUT_BMX-type IODDT Objects

At a Glance

The following tables describe the T_ANA_OUT_BMX-type IODDT objects applicable to the **BME AHO 0412**, **BMX AMO 0210**, **BMX AMO 0410** and **BMX AMO 0802** analog output modules and the outputs of the **BMX AMM 600** mixed module.

Value of the Output

The analog output measurement object is as follows.

Standard symbol	Type	Access	Meaning	Address
VALUE	INT	R	Analog output measurement.	%QWr.m.c.0

%lr.m.c.ERR error bit

The %lr.m.c.ERR error bit is as follows.

Standard symbol	Type	Access	Meaning	Address
CH_ERROR	BOOL	R	Error bit for analog channel.	%lr.m.c.ERR

Value Forcing

The value forcing bit is as follows.

Standard symbol	Type	Access	Meaning	Address
FORCING_VALUE	INT	R	Forcing of the value.	%lWr.m.c.0

Channel forcing indicator.

The meaning of the forcing control bits of the channel (%lWr.m.c.1) is as follows.

Standard symbol	Type	Access	Meaning	Address
CHANNEL_FORCED	BOOL	R	Forcing of the channel.	%MWr.m.c.1.1

Explicit Exchange Execution Flag: EXCH_STS

The meaning of the exchange control bits of the channel EXCH_STS (%MWr.m.c.0) is as follows:

Standard symbol	Type	Access	Meaning	Address
STS_IN_PROGR	BOOL	R	Read channel status words in progress.	%MWr.m.c.0.0
CMD_IN_PROGR	BOOL	R	Command parameter exchange in progress.	%MWr.m.c.0.1
ADJ_IN_PROGR	BOOL	R	Adjustment parameter exchange in progress.	%MWr.m.c.0.2

Explicit Exchange Report: EXCH_RPT

The meaning of the EXCH_RPT (%MWr.m.c.1) report bits is as follows:

Standard symbol	Type	Access	Meaning	Address
STS_ERR	BOOL	R	Read error detected for channel status words.	%MWr.m.c.1.0
CMD_ERR	BOOL	R	Error detected during command parameter exchange.	%MWr.m.c.1.1
ADJ_ERR	BOOL	R	Error detected while exchanging adjustment parameters.	%MWr.m.c.1.2
RECONF_ERR	BOOL	R	Error detected while reconfiguring the channel.	%MWr.m.c.1.15

Standard Channel Status: CH_FLT

The following table explains the meaning of the CH_FLT (%MWr.m.c.2) status word bits. Reading is performed by a READ_STS (IODDT_VAR1).

Standard symbol	Type	Access	Meaning	Address
ACT_WIRE_FLT	BOOL	R	Actuator wire open or short.	%MWr.m.c.2.0
RANGE_FLT	BOOL	R	Range under/overflow detected error.	%MWr.m.c.2.1
SHORT_CIRCUIT	BOOL	R	Short-circuit.	%MWr.m.c.2.2
CAL_PRM_FLT	BOOL	R	Calibration parameters not configured.	%MWr.m.c.2.3
INTERNAL_FLT	BOOL	R	Inoperative channel.	%MWr.m.c.2.4
CONF_FLT	BOOL	R	Different hardware and software configurations.	%MWr.m.c.2.5
COM_FLT	BOOL	R	Problem detected communicating with the PLC.	%MWr.m.c.2.6
APPLI_FLT	BOOL	R	Application detected error (adjustment or configuration detected error).	%MWr.m.c.2.7
ALIGNED_CH	BOOL	R	Aligned channels.	%MWr.m.c.3.0
INT_CAL_FLT	BOOL	R	Calibration parameters not defined.	%MWr.m.c.3.2
INT_PS_FLT	BOOL	R	Internal power supply detected error.	%MWr.m.c.3.3
INT_SPI_FLT	BOOL	R	Serial link detected error.	%MWr.m.c.3.4
RANGE_UNF	BOOL	R	Range underflow.	%MWr.m.c.3.6
RANGE_OVF	BOOL	R	Range overflow.	%MWr.m.c.3.7

Command Control

The following table explains the meaning of the COMMAND_ORDER (%MWr.m.c.4) status word bit. Reading is performed by a READ_STS:

Standard symbol	Type	Access	Meaning	Address
FORCING_UNFORCING_ORDER	BOOL	R/W	Forcing/unforcing command.	%MWr.m.c.4.13

Parameters

The following table shows the meaning of the words %MWr.m.c.5 to %MWr.m.c.8. The requests used are those associated with the parameters (READ_PARAM and WRITE_PARAM).

Standard symbol	Type	Access	Meaning	Address
CMD_FORCING_VALUE	INT	R/W	Forcing value to be applied.	%MWr.m.c.5
FALLBACK	INT	R/W	Fallback value.	%MWr.m.c.7
ALIGNMENT	INT	R/W	Alignment value.	%MWr.m.c.8

NOTE: In order to force a channel, you have to use the WRITE_CMD (%MWr.m.c.5) instruction and set the %MWr.m.c.4.13 bit to 1.

NOTE: To unforce a channel and use it normally, you have to set the %MWr.m.c.4.13 bit to 0.

Detailed Description of T_ANA_IN_GEN-type IODDT Objects

At a Glance

The tables below present the T_ANA_IN_GEN-type IODDT objects that are applicable to the **BME AHI 0812**, **BMX AMI 0410**, **BMX AMI 0800** and **BMX AMI 0810** input modules, to the inputs of the **BMX AMM 600** mixed module and to the **BMX ART 0414/0814** analog input module.

Input Measurement

The analog input measurement object is as follows.

Standard symbol	Type	Access	Meaning	Address
VALUE	INT	R	Analog input measurement.	%IWr.m.c.0

%Ir.m.c.ERR Error Bit

The %Ir.m.c.ERR error bit is as follows:

Standard symbol	Type	Access	Meaning	Address
CH_ERROR	BOOL	R	Detected error bit for analog channel.	%Ir.m.c.ERR

Detailed Description of T_ANA_OUT_GEN-type IODDT Objects

At a Glance

The following tables describe the T_ANA_OUT_GEN-type IODDT objects applicable to the **BME AHO 0412**, **BMX AMO 0210**, **BMX AMO 0410** and **BMX AMO 0802** analog output modules and to the output of the **BMX AMM 600** mixed module.

Input Measurement

The analog output measurement object is as follows.

Standard symbol	Type	Access	Meaning	Address
VALUE	INT	R	Analog output measurement.	%IWr.m.c.0

%Ir.m.c.ERR Error Bit

The %Ir.m.c.ERR error bit is as follows.

Standard symbol	Type	Access	Meaning	Address
CH_ERROR	BOOL	R	Detected error bit for analog channel.	%Ir.m.c.ERR

Details of the Language Objects of the IODDT of Type T_GEN_MOD

Introduction

The Modicon X80 modules have an associated IODDT of type T_GEN_MOD.

Observations

In general, the meaning of the bits is given for bit status 1. In specific cases an explanation is given for each status of the bit.

Some bits are not used.

List of Objects

The table below presents the objects of the IODDT.

Standard Symbol	Type	Access	Meaning	Address
MOD_ERROR	BOOL	R	Module detected error bit	%I _r .m.MOD.ERR
EXCH_STS	INT	R	Module exchange control word	%MWr.m.MOD.0
STS_IN_PROGR	BOOL	R	Reading of status words of the module in progress	%MWr.m.MOD.0.0
EXCH_RPT	INT	R	Exchange report word	%MWr.m.MOD.1
STS_ERR	BOOL	R	Event when reading module status words	%MWr.m.MOD.1.0
MOD_FLT	INT	R	Internal detected errors word of the module	%MWr.m.MOD.2
MOD_FAIL	BOOL	R	module inoperable	%MWr.m.MOD.2.0
CH_FLT	BOOL	R	Inoperative channel(s)	%MWr.m.MOD.2.1
BLK	BOOL	R	Terminal block incorrectly wired	%MWr.m.MOD.2.2
CONF_FLT	BOOL	R	Hardware or software configuration anomaly	%MWr.m.MOD.2.5
NO_MOD	BOOL	R	Module missing or inoperative	%MWr.m.MOD.2.6
EXT_MOD_FLT	BOOL	R	Internal detected errors word of the module (Fipio extension only)	%MWr.m.MOD.2.7
MOD_FAIL_EXT	BOOL	R	Internal detected error, module unserviceable (Fipio extension only)	%MWr.m.MOD.2.8
CH_FLT_EXT	BOOL	R	Inoperative channel(s) (Fipio extension only)	%MWr.m.MOD.2.9
BLK_EXT	BOOL	R	Terminal block incorrectly wired (Fipio extension only)	%MWr.m.MOD.2.10
CONF_FLT_EXT	BOOL	R	Hardware or software configuration anomaly (Fipio extension only)	%MWr.m.MOD.2.13
NO_MOD_EXT	BOOL	R	Module missing or inoperative (Fipio extension only)	%MWr.m.MOD.2.14

Analog Device DDT

Introduction

This topic describes the Unity Pro **Analog Device DDT**, the instance default naming is described in Device DDT Instance Naming Rule (see *Unity Pro, Program Languages and Structure, Reference Manual*).

Regarding the device DDT, its name contains the following information:

- platform with:
 - U for unified structure between Modicon X80 module and Quantum
- device type (ANA for analog)
- function (STD for standard)
 - STD for standard
 - TEMP for temperature
- direction:
 - IN
 - OUT
- max channel (2, 4, 8)

Example: For a Modicon X80 module with 4 standard inputs and 2 outputs the Device Derived Data Type is T_U_ANA_STD_IN_4_OUT_2

Adjustment Parameter limitation

In Quantum EIO and M580 RIO, adjustment parameters cannot be changed from the PLC application during operation (no support of READ_PARAM, WRITE_PARAM, SAVE_PARAM, RESTORE_PARAM).

The concerned analog input parameters are:

- FILTER_COEFF
Value of filter coefficient
- ALIGNMENT_OFFSET
Alignment offset value

The concerned analog output parameters are:

- FALLBACK
Fallback value
- ALIGNMENT
Alignment value

List of Implicit Device DDT

The following table shows the list of device DDT and their **X80** modules:

Device DDT Type	Modicon X80 Devices
T_U_ANA_STD_IN_4	BMX AMI 0410
T_U_ANA_STD_IN_8	BME AHI 0812 BMX AMI 0800 BMX AMI 0810
T_U_ANA_STD_OUT_2	BMX AMO 0210
T_U_ANA_STD_OUT_4	BME AHO 0412 BMX AMO 0410
T_U_ANA_STD_OUT_8	BMX AMO 0802
T_U_ANA_STD_IN_4_OUT_2	BMX AMM 0600
T_U_ANA_TEMP_IN_4	BMX ART 0414
T_U_ANA_TEMP_IN_8	BMX ART 0814

Implicit Device DDT Description

The following table shows the T_U_ANA_STD_IN_x and the T_U_ANA_STD_OUT_y status word bits:

Standard Symbol	Type	Meaning	Access
MOD_HEALTH	BOOL	0 = the module has a detected error	read
		1 = the module is operating correctly	
MOD_FLT	BYTE	internal detected errors byte (see page 261) of the module	read
ANA_CH_IN	ARRAY [0...x-1] of T_U_ANA_STD_CH_IN	array of structure	–
ANA_CH_OUT	ARRAY [0..y-1] of T_U_ANA_STD_CH_OUT	array of structure	–

The following table shows the T_U_ANA_STD_IN_x_OUT_y status word bits:

Standard Symbol	Type	Meaning	Access
MOD_HEALTH	BOOL	0 = the module has a detected error	read
		1 = the module is operating correctly	
MOD_FLT	BYTE	internal detected errors byte (see page 261) of the module	read

Standard Symbol	Type	Meaning	Access
ANA_CH_IN	ARRAY [0..x-1] of T_U_ANA_STD_CH_IN	array of structure	–
ANA_CH_OUT	ARRAY [x..x+y-1] of T_U_ANA_STD_CH_OUT	array of structure	–

The following table shows the T_U_ANA_TEMP_IN_x status word bits:

Standard Symbol	Type	Meaning	Access
MOD_HEALTH	BOOL	0 = the module has a detected error 1 = the module is operating correctly	read
MOD_FLT	BYTE	internal detected errors byte (see page 261) of the module	read
ANA_CH_IN	ARRAY [[0..x-1] of T_U_ANA_TEMP_CH_IN	array of structure	–

The following table shows the T_U_ANA_STD_CH_IN[0..x-1] structure status word bits:

Standard Symbol	Type	Bit	Meaning	Access	
FCT_TYPE	WORD	–	0 = channel is not used 1 = channel is used	read	
CH_HEALTH	BOOL	–	0 = the channel has a detected error 1 = the channel is operating correctly	read	
CH_WARNING	BOOL	–	not used	–	
ANA	STRUCT	–	T_U_ANA_VALUE_IN	read	
MEASURE_STS [INT]	CH_ALIGNED	BOOL	0	aligned channel	read
	LOWER_LIMIT	BOOL	5	measurement within lower tolerance area	read
	UPPER_LIMIT	BOOL	6	measurement within upper tolerance area	read
	INT_OFFSET_ERROR	BOOL	8	internal offset detected error	read
	IN_REF_ERROR	BOOL	10	internal reference detected error	read
	POWER_SUP_ERROR	BOOL	11	not used	read
	SPI_COM_ERROR	BOOL	12	SPI communication detected error	read

The following table shows the T_U_ANA_STD_CH_OUT[0..y-1] status word bits:

Standard Symbol	Type	Meaning	Access
FCT_TYPE	WORD	0 = channel is not used 1 = channel is used	read
CH_HEALTH	BOOL	0 = the channel has a detected error 1 = the channel is operating correctly	read
ANA	STRUCT	T_U_ANA_VALUE_OUT	read

The following table shows the T_U_ANA_VALUE_IN[0..x-1] and T_U_ANA_VALUE_OUT[0..y-1] structure status word bits:

Standard Symbol	Type	Bit	Meaning	Access
VALUE	INT	-	if FORCE_CMD = 1 then VALUE = FORCED_VALUE	read ⁽¹⁾
			if FORCE_CMD = 0 then VALUE = TRUE_VALUE	
FORCED_VALUE	INT	-	forced value of the channel	read / write
FORCE_CMD	BOOL	-	0 = Un-force command	read / write
			1 = force command	
FORCE_STATE	BOOL	-	0 = value is not forced	read
			1 = value is forced	
TRUE_VALUE ⁽²⁾	INT	-	True value of the channel (from the sensor)	read
1 VALUE of the T_U_ANA_VALUE_OUT structure word can be accessed in read / write 2 TRUE_VALUE of the T_U_ANA_VALUE_OUT is the value calculated from the application.				

The following table shows the T_U_ANA_TEMP_CH_IN[0..x-1] structure status word bits:

Standard Symbol	Type	Bit	Meaning	Access
FCT_TYPE	WORD	-	0 = channel is not used	read
			1 = channel is used	
CH_HEALTH	BOOL	-	0 = the channel has a detected error	read
			1 = the channel is operating correctly	
CH_WARNING	BOOL	-	not used	-
ANA	STRUCT	-	T_U_ANA_VALUE_IN	read
MEASURE_STS	INT	-	measurement status	read
CJC_VALUE	INT	-	Cold junction compensation value (1/10 °C)	read

Use and Description of DDT for Explicit Exchange

The following table shows the DDT type used for the variables connected to dedicated EFB parameter to perform an explicit exchange:

DDT	Description	
T_M_ANA_STD_CH_STS	Structure to read the channel status of an analog module.	Depending on the I/O module location, the DDT can be connected to the <code>STS</code> output parameter of the EFB: <ul style="list-style-type: none"> ● <code>READ_STS_QX</code> (<i>see Unity Pro, I/O Management, Block Library</i>) when the module is located in Quantum EIO. ● <code>READ_STS_MX</code> (<i>see Unity Pro, I/O Management, Block Library</i>) when the module is located in a M580 local rack or in M580 RIO drops.
T_M_ANA_STD_CH_IN_STS	Structure to read the channel status of an analog output module.	
T_M_ANA_STD_CH_OUT_STS	Structure to read the channel status of an analog output module.	
T_M_ANA_TEMP_CH_STS	Structure to read the channel status of an analog temperature input module.	
T_M_ANA_STD_CH_IN_PRM	Structure for adjustment parameters of a channel of an analog input module in a M580 local rack.	The DDT can be connected to the <code>PARAM</code> output parameter of the EFB: <ul style="list-style-type: none"> ● <code>READ_PARAM_MX</code> (<i>see Unity Pro, I/O Management, Block Library</i>) to read module parameters. ● <code>WRITE_PARAM_MX</code> (<i>see Unity Pro, I/O Management, Block Library</i>) to write module parameters. ● <code>SAVE_PARAM_MX</code> (<i>see Unity Pro, I/O Management, Block Library</i>) to save module parameters. ● <code>RESTORE_PARAM_MX</code> (<i>see Unity Pro, I/O Management, Block Library</i>) to restore the new parameters of the module.
T_M_ANA_STD_CH_OUT_PRM	Structure for adjustment parameters of a channel of an analog output module in a M580 local rack.	
<p>NOTE: Targeted channel address (<code>ADDR</code>) can be managed with <code>ADDMX</code> (<i>see Unity Pro, Communication, Block Library</i>) EF (connect the output parameter <code>OUT</code> to the input parameter <code>ADDR</code> of the communication functions).</p>		

The following table shows the DDT structure for T_M_ANA_STD_CH_STS, T_M_ANA_STD_CH_IN_STS, T_M_ANA_STD_CH_OUT_STS and T_M_ANA_TEMP_CH_STS:

Standard Symbol		Type	Bit	Meaning	Access
CH_FLT [INT]	SENSOR_FLT	BOOL	0	detected sensor faults	read
	RANGE_FLT	BOOL	1	detected range fault	read
	CH_ERR_RPT	BOOL	2	channel detected error report	read
	INTERNAL_FLT	BOOL	4	internal detected error: module out of order	read
	CONF_FLT	BOOL	5	detected configuration fault: different hardware and software configurations	read
	COM_FLT	BOOL	6	detected problem communicating with the PLC	read
	APPLI_FLT	BOOL	7	detected application fault	read
	COM_FLT_ON_EVT ⁽¹⁾	BOOL	8	detected communication fault on event	read
	OVR_ON_CH_EVT ⁽¹⁾	BOOL	9	detected overrun fault on CPU event	read
	OVR_ON_CH_EVT ⁽¹⁾	BOOL	10	detected overrun fault on channel event	read
CH_FLT_2 [INT]	NOT_READY	BOOL	0	Channel not ready	read
	COLD_JUNCTION_FLT ⁽²⁾	BOOL	1	Cold junction compensation detected error	read
	CALIB_FLT	BOOL	2	detected calibration fault	read
	INT_OFFS_FLT	BOOL	3	detected internal offset error	read
	IN_REF_FLT	BOOL	4	detected internal reference fault	read
	INT_SPI_PS_FLT	BOOL	5	detected internal serial link or power supply error	read
	RANGE_UNF	BOOL	6	recalibrated channel or range underflow	read
	RANGE_OVF	BOOL	7	aligned channel or range overflow	read
(1) Only available with T_M_ANA_STD_CH_IN_STS and T_M_ANA_STD_CH_OUT_STS.					
(2) Only available with T_M_ANA_TEMP_CH_STS.					

The following table shows the T_M_ANA_STD_CH_IN_PRM DDT structure:

Standard Symbol	Type	Bit	Meaning	Access
FILTERCOEFF	INT	–	Value of filter coefficient	read/write
ALIGNMENT_OFFSET	INT	–	Alignment offset value	read/write
THRESHOLD0	INT	–	Reserved for evolution.	–
THRESHOLD1	INT	–	Reserved for evolution.	–

The following table shows the T_M_ANA_STD_CH_OUT_PRM DDT structure:

Standard Symbol	Type	Bit	Meaning	Access
FALLBACK	INT	–	fallback value	read/write
ALIGNMENT	INT	–	alignment value	read/write

MOD_FLT Byte Description

MOD_FLT Byte in Device DDT

MOD_FLT byte structure:

Bit	Symbol	Description
0	MOD_FAIL	<ul style="list-style-type: none"> ● 1: Internal detected error or module failure detected. ● 0: No detected error
1	CH_FLT	<ul style="list-style-type: none"> ● 1: Inoperative channels. ● 0: Channels are operative.
2	BLK	<ul style="list-style-type: none"> ● 1: Terminal block detected error. ● 0: No detected error. <p>NOTE: This bit may not be managed.</p>
3	–	<ul style="list-style-type: none"> ● 1: Module in self-test. ● 0: Module not in self-test. <p>NOTE: This bit may not be managed.</p>
4	–	Not used.
5	CONF_FLT	<ul style="list-style-type: none"> ● 1: Hardware or software configuration detected error. ● 0: No detected error.
6	NO_MOD	<ul style="list-style-type: none"> ● 1: Module is missing or inoperative. ● 0: Module is operating. <p>NOTE: This bit is managed only by modules located in a remote rack with a BME CRA 312 10 adapter module. Modules located in the local rack do not manage this bit that remains at 0.</p>
7	–	Not used.

Analog Device Ethernet Remote I/O Forcing Mode

Introduction

Input and output values of Modicon X80 analog modules can be forced through the device DDT value.

NOTE: Modicon X80 discrete modules values are forced using the `EBOOL` mechanism, refer to chapter **Force Mode** (see *Unity Pro, Operating Modes*).

Forcing input and output values in a running controller can have serious consequences to the operation of a machine or process. Only those who understand the implications in the controlling logic, and who understand the consequences of forced I/O on the machine or process, should attempt to use this function.

WARNING

UNINTENDED EQUIPMENT OPERATION

You must have prior knowledge of the process, the controlled equipment and the modified behavior in Unity Pro before attempting to force analog inputs or outputs.

Failure to follow these instructions can result in death, serious injury, or equipment damage.

Modicon X80 Analog Device `T_U_ANA_VALUE_••` Structure

The following table shows the content of analog devices DDT (see page 254) type used to force a value:

Standard Symbol	Type	Meaning
VALUE	INT	Channel value. It represents the value used in the application and is either the <code>FORCED_VALUE</code> or the <code>TRUE_VALUE</code> depending on the <code>FORCED_STATE</code> .
FORCED_VALUE	INT	Value applied to an output or interpreted as an input during forcing. If <code>FORCED_STATE = 1</code> then <code>VALUE = FORCED_VALUE</code>
FORCE_CMD	BOOL	Parameter used to force or unforce an analog output or input value
FORCED_STATE	BOOL	Forcing status: <ul style="list-style-type: none"> ● 0: value is not forced ● 1: value is forced
TRUE_VALUE	INT	Represents the true value of the analog output or input whatever the state of the forcing command

Forcing a Value with the Animation Tables

To force a DDT value in an animation table proceed as follows:

Step	Action
1	Select the chosen analog channel.
2	Set the FORCED_VALUE parameter value of the selected channel to the chosen value, for details on how to set a value, refer to chapter <i>Modification Mode</i> (see <i>Unity Pro, Operating Modes</i>).
3	Set the FORCE_CMD parameter to 1.
4	Result: <ul style="list-style-type: none"> ● Check that forcing is applied: FORCED_STATE needs to be equal to 1 ● VALUE = FORCED_VALUE

Unforcing a Value with the Animation Tables

To unforce a DDT value in an animation table proceed as follows:

Step	Action
1	Select the chosen analog channel.
2	Set the FORCE_CMD parameter to 0.
3	Result: <ul style="list-style-type: none"> ● Check that forcing is released: FORCED_STATE needs to be equal to 0 ● VALUE = TRUE_VALUE

Chapter 14

Analog Module Debugging

Subject of this Chapter

This chapter describes the debugging aspect of the analog modules.

What Is in This Chapter?

This chapter contains the following topics:

Topic	Page
Introducing the Debug Function of an Analog Module	266
Description of the Analog Module Debug Screen	267
Selecting the Adjustment Values for the Input Channels and Measurement Forcing	269
Modification of Output Channels Adjustment Values	271

Introducing the Debug Function of an Analog Module

Introduction

This function is only accessible in online mode. For each input/output module of the project, it can be used to:

- display measurements
- display the parameters of each channel (channel state, filtering value, etc.)
- access the diagnostics and adjustment of the selected channel (masking the channel, etc.)

The function also gives access to the module diagnostics in the case of an event.

Procedure

The procedure to access the **Debugging** function is as follows.

Step	Action
1	configure the module
2	transfer the application to the PLC
3	change to online mode
4	in the rack configuration screen, double-click on the module
5	select the Debugging tab

Description of the Analog Module Debug Screen

At a Glance

The Debug Screen displays, in real time, the current value and status for each of the selected module's channels.

Illustration

The figure below shows a sample debugging screen.

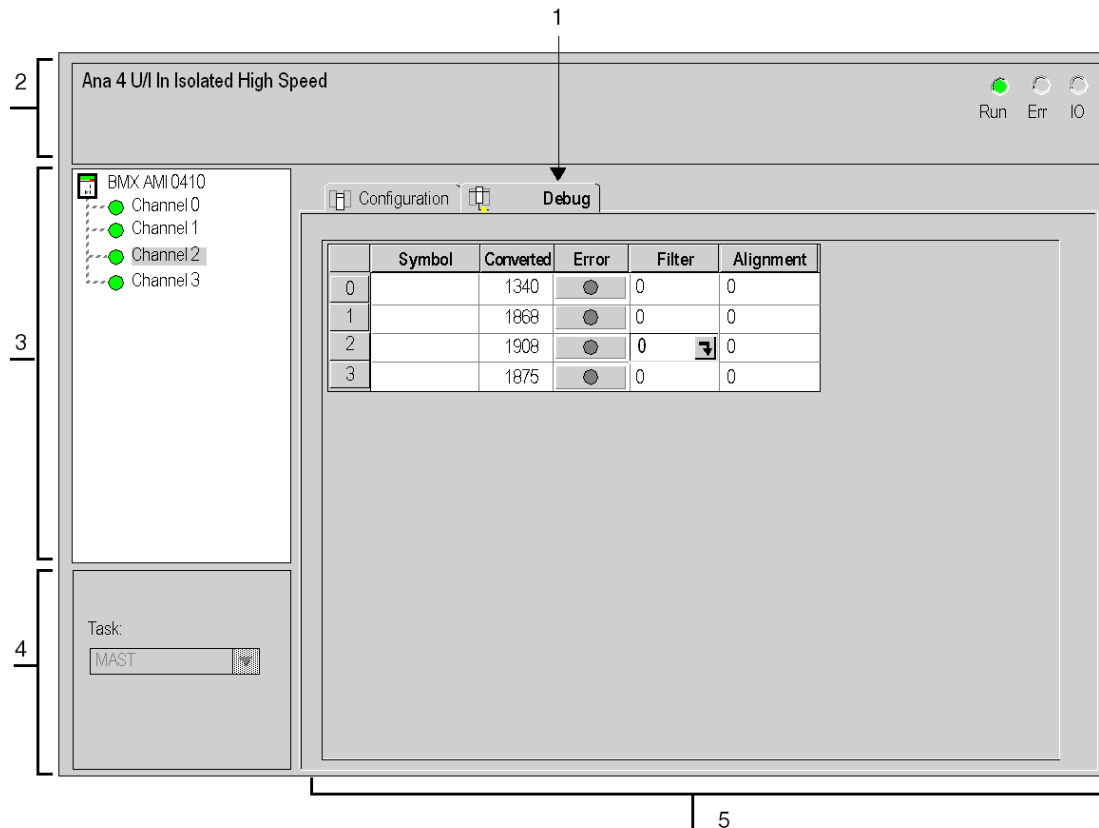

Description

The table below shows the different elements of the debug screen and their functions.

Address	Element	Function
1	Tabs	The tab in the foreground indicates the mode in progress (Debug in this example). Each mode can be selected by the corresponding tab. The available modes are: <ul style="list-style-type: none"> ● Debug which can be accessed only in online mode. ● Configuration.
2	Module area	Specifies the shortened name of the module. In the same area there are 3 LEDs which indicate the status of the module in online mode: <ul style="list-style-type: none"> ● RUN indicates the operating status of the module, ● ERR indicates an internal detected error in the module, ● I/O indicates an event from outside the module or an application error.
3	Channel area	Is used: <ul style="list-style-type: none"> ● To select a channel. ● To display the Symbol, name of the channel defined by the user (using the variable editor).
4	General parameters area	Specifies the MAST or FAST task configured. This information cannot be modified.
5	Viewing and control area	Displays the value and status for each channel in the module in real-time. The symbol column displays the symbol associated with the channel when the user has defined this (from the variable editor). This area provides direct access to channel by channel diagnostics when these are inoperative (indicated by error column LED ,which turns red). <ul style="list-style-type: none"> ● Access to the settings of the filtering, alignment and fallback values of the outputs, ● To channel-by-channel diagnostics when channels have an error (indicated by the LED built into the diagnostics access button, which turns red).

NOTE: LEDs and commands not available appear grayed out.

Selecting the Adjustment Values for the Input Channels and Measurement Forcing

At a Glance

This function is used to modify the filter, alignment and forcing value of one or more channels of an analog module.

The available commands are:

- forcing
- filter
- alignment

To align several analog channels on the BMX AMO/AMI/AMM/ART modules, we recommend proceeding channel by channel. Test each channel after alignment before moving to the next channel, in order to apply the parameters correctly.

Procedure

The table below summarizes the procedure for modifying the filter, forcing and alignment values.

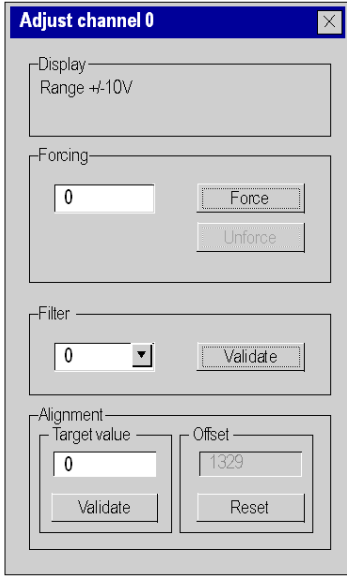
Step	Action for a channel
1	Access the debug screen.
2	<p>Select the channel to be modified in the Display zone and double-click in the corresponding box.</p> <p>Result: The Adjust channel dialog box appears.</p> 
3	Click on the text field in the Forcing field. Enter the forcing value. Send the forcing order by clicking on the Forcing button.
4	Click on the drop-down menu in the Filter field, and define the new selected filter value. Confirm this selection by clicking OK .
5	In the Alignment field click on the text field and define the target value. Confirm this selection by clicking OK .
6	Close the Adjust channel dialog box. Results: The new filter, forcing or alignment value then appears in the box corresponding to the selected channel in the Filter , Forcing or Alignment column of the Display area.

Modification of Output Channels Adjustment Values

At a Glance

This function is used to modify the forcing, fallback and alignment values for one or several output channels of an analog module.

The available commands are:

- forcing
- fallback
- alignment

Procedure

The table below summarizes the procedure for modifying the values to be applied at the output channels:

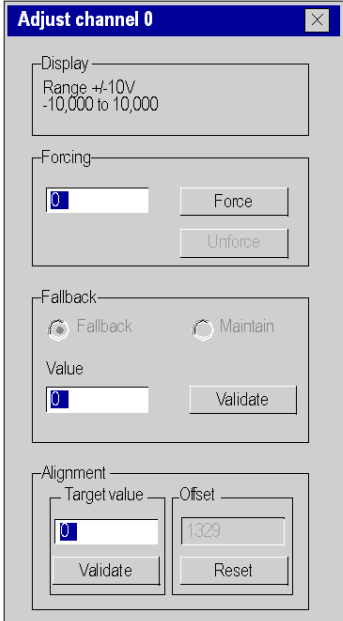
Step	Action for a channel
1	Access the debug screen.
2	<p>Select the channel in the Display zone and double-click in the corresponding box. Result: The Adjust channel dialog box appears.</p> 

Step	Action for a channel
3	Click on the text field in the Forcing field of the Adjust channel dialog box. Enter the forcing value. Send the forcing order by clicking on the Forcing button.
4	Click on the box in the Value field of the Fallback dialog box and enter the new fallback value. Confirm this new value by clicking OK .
5	Click on the text field in the Alignment field of the Adjust channel dialog box and define the target value. Confirm this selection by clicking OK .
6	Close the Adjust channel dialog box.

Chapter 15

Analog Module Diagnostics

Subject of this Chapter

This chapter describes the diagnostics aspect in the implementation of analog modules.

What Is in This Chapter?

This chapter contains the following topics:

Topic	Page
Diagnostics of an Analog Module	274
Detailed Diagnostics by Analog Channel	276

Diagnostics of an Analog Module

At a Glance

The Module diagnostics function displays errors when they occur, classified according to category:

- **Internal detected error:**
 - module malfunction
 - self-testing error
- **External events:**
 - Wiring control (broken-wire, overload or short-circuit)
 - Under range/over range
- **Other errors:**
 - configuration error
 - module missing or off
 - inoperative channel

A module error is indicated by a number of LEDs changing to red, such as:

- in the rack-level configuration editor:
 - the LED of the rack number
 - the LED of the slot number of the module on the rack
- in the module-level configuration editor:
 - the **Err** and **I/O** LEDs, depending on the type of error
 - the **Channel** LED in the **Channel** field

Procedure

The table below shows the procedure for accessing the module Fault screen.

Step	Action
1	Open the module debugging screen.
2	Click on the module reference in the channel zone and select the Fault tab. Result: The list of module errors appears.

Note: It is not possible to access the module diagnostics screen if a configuration error, major breakdown error, or module missing error occurs. The following message then appears on the screen: "The module is missing or different from that configured for this position."

Detailed Diagnostics by Analog Channel

At a Glance

The channel Diagnostics function displays errors when they occur, classified according to category:

- **Internal errors**
 - inoperative channel
 - calibration error
- **External events**
 - sensor link event
 - range overflow/underflow
 - cold junction compensation error
- **Other errors**
 - configuration error
 - communication loss
 - application error
 - value outside range (output channel)
 - channel not ready

A channel error is indicated in the **Debug** tab when the  LED, located in the **Error** column, turns red.

Procedure

The table below shows the procedure for accessing the channel Fault screen.

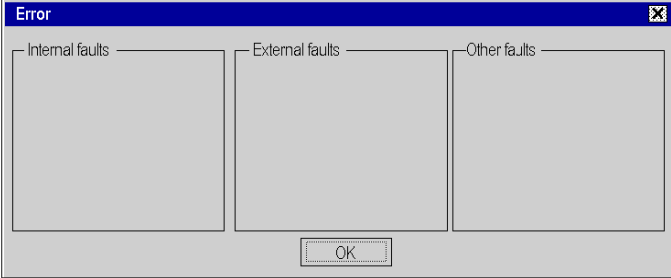
Step	Action
1	Open the module debugging screen.
2	<p>For the inoperative channel, click on the button  situated in the Error column.</p> <p>Result: The list of channel errors appears.</p>  <p>Note: Channel diagnostics information can also be accessed by program (instruction READ_STS).</p>

Chapter 16

Operating Modules from the Application

Subject of this Chapter

This chapter explains how to operate the analog input/output modules from an application.

What Is in This Chapter?

This chapter contains the following sections:

Section	Topic	Page
16.1	Access to the Measurements and Statuses	280
16.2	Additional Programming Features	287

Section 16.1

Access to the Measurements and Statuses

Subject of this Section

This section indicates how to configure an analog module in order to be able to access the input/outputs measurements and the various statuses.

What Is in This Section?

This section contains the following topics:

Topic	Page
Addressing of the Analog Module Objects	281
Module Configuration	283

Addressing of the Analog Module Objects

At a Glance

The addressing of the main bit and word objects of the analog input/output modules depends upon:

- the rack address
- the physical position of the module in the rack
- the module channel number

NOTE: You can access the modules either via topological or State RAM addresses (*see Unity Pro, Operating Modes*).

Description

Addressing is defined in the following way.

%	I, Q, M, K	X, W, D, F	r	.	m	.	c	.	i	.	j
Symbol	Object type	Format	Rack		Module position		Channel no.		Rank		Word bit

The table below describes the different elements that make up addressing.

Family	Element	Meaning
Symbol	%	-
Object type	I	Image of the physical input of the module.
	Q	Image of the physical output of the module. This information is exchanged automatically for each cycle of the task to which they are attached.
	M	Internal variable. This read or write information is exchanged at the request of the application.
	K	Internal constant. This configuration information is available as read only.
Format (size)	X	Boolean. For Boolean objects the X can be omitted.
	W	Single length.
	D	Double length.
	F	Floating point.
Rack address	r	Rack address.
Module position	m	Module position number in the rack.
Channel no.	c	Channel no. 0 to 127 or MOD (MOD: channel reserved for managing the module and parameters common to all the channels).

Family	Element	Meaning
Rank	i	Word rank. 0 to 127 or ERR (ERR: indicates an error in the word).
Word bit	j	Position of the bit in the word.

Examples

The table below shows some examples of analog object addressing.

Object	Description
%I1.3.MOD.ERR	Error information for the analog input module located in position 3 on rack 1.
%I1.4.1.ERR	Channel 1 error information for the analog input module located in position 4 on rack 1.
%IW1.2.2	Image word for the analog input 2 of the module located in position 2 on rack 1.
%QW2.4.1	Image word for the analog output 1 of the module located in position 4 on rack 2.

Module Configuration

At a Glance

The application used here as an example manages liquid levels in a tank. The tank is filled by a pump and drained using a valve. The different levels of the tank are measured with sensors placed above the tank. The tank should not be filled with more than 100 liters of liquid.

Once the tank is full, the pump stops, and the operator drains the tank manually.

This application requires the use of a BMX AMI 0410 analog input module and a BMX AMO 0210 analog output module. This application may also require a BMX AMM 0600 input/output module.

Tank Management Grafcet

The application's grafcet is as follows:

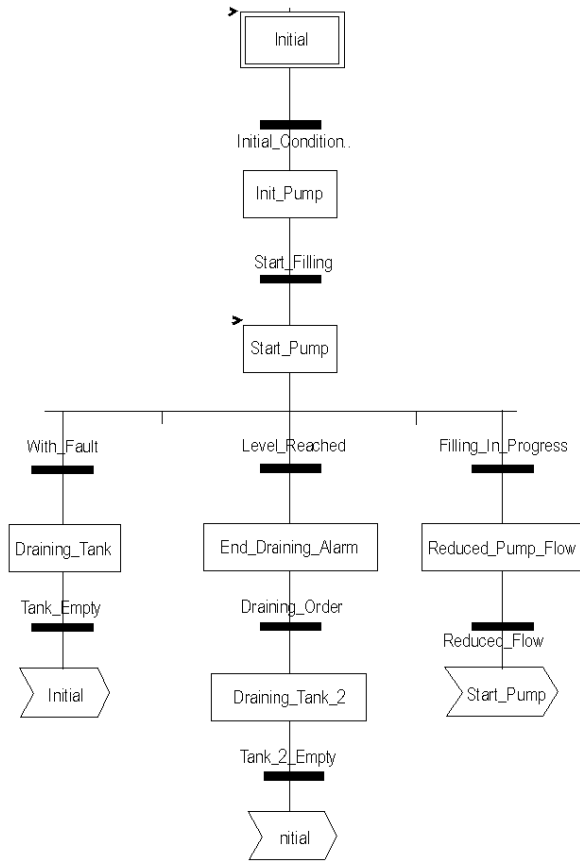

Using the Measurements

We are going to configure the BMX_AMI_0410 analog input module so that we can retrieve the level of the liquid in the tank.

Step	Action
1	In the Project browser and in Variables & FB instances, double-click on Elementary variables.
2	Create the INT-type variable, Level.
3	In the Address column, enter the address associated with this variable. In our example, we consider that the sensor is connected to channel 0 of the BMX AMI 0410 module. This module is in turn connected to slot 1 of rack 0. We therefore have the following address: %IW0.1.0. Illustration: 

This variable can be used to check whether the level of liquid in the tank has reached maximum level.

To do this, the following line of code can be associated with the `Level_Reached` transition of the grafset.



If the level of liquid in the tank reaches or exceeds the maximum level, the `Level_Reached` transition is enabled.

Using the Statuses

We will need to program the `With_fault` transition so that we can stop the pump in three cases:

- the maximum liquid level has been reached
- the pump has been stopped manually
- the measurement falls beyond the upper tolerance area

Before we can use the bit, which will indicate whether the measure still falls within the upper tolerance area (`%IW.r.m.c.1.6`), we need to define the display format and scale of the channel used.

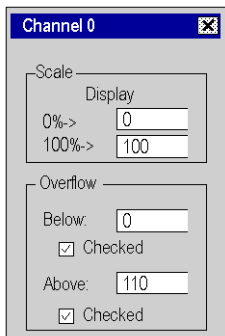
Step	Action
1	Access the hardware configuration screen for the appropriate module.
2	Select the range 0...10 V (<i>see page 228</i>) for channel 0.
4	<p>Access the Parameters dialog box (<i>see page 231</i>) for the channel in order to input the following parameters:</p>  <p>The upper tolerance area will be between 100 and 110 liters.</p>
5	Confirm your changes by closing the dialog box.
6	Validate the change with Edit->Validate .

The code associated with the fault control transition looks like this:



Section 16.2

Additional Programming Features

Subject of this Section

This section presents some useful additional features for the programming of applications that use analog input/output modules.

What Is in This Section?

This section contains the following topics:

Topic	Page
Presentation of Language Objects Associated with the Analog Modules	288
Implicit Exchange Language Objects Associated with Analog Modules	289
Explicit Exchange Language Objects Associated with Analog Modules	290
Management of Exchanges and Reports with Explicit Objects	293
Language Objects Associated with Configuration	297

Presentation of Language Objects Associated with the Analog Modules

General

Analog modules are associated with different IODDTs.

The IODDTs are predefined by the manufacturer. They contain input/output language objects belonging to a channel of an analog module.

There are several distinct IODDT types for the analog module:

- `T_ANA_IN_BMX` specific to analog input modules such as the BME AHI 0812 and BMX AMI 0410, and specific to the inputs of the BMX AMM 600 mixed module
- `T_ANA_IN_T_BMX` specific to analog input modules such as the BMX ART 0414/0814
- `T_ANA_OUT_BMX` specific to analog output modules such as the BME AHO 0412 and BMX AMO 0210, and specific the outputs of the BMX AMM 600 mixed module
- `T_ANA_IN_GEN` specific to all analog input modules such as the BME AHI 0812, BMX AMI 0410, BMX ART 0414/0814, and the inputs of the BMX AMM 600 mixed module

NOTE: IODDT variables may be created in 2 ways:

- by using the **I/O Objects** tab,
- by using the data editor.

Types of Language Objects

In each IODDT, there exists a set of language objects you can use to control the modules and check their correct operation.

There are 2 types of language objects:

- **Implicit Exchange Objects**, which are automatically exchanged at each cycle of the task assigned to the module. They concern the inputs/outputs of the module (measurement results, information, commands, and so forth).
- **Explicit Exchange Objects**, which are exchanged at the application request, using explicit exchange instructions. They are used to set the module and perform diagnostics.

Implicit Exchange Language Objects Associated with Analog Modules

At a Glance

An integrated interface or the addition of a module automatically enhances the language objects application used to program this interface or module.

These objects correspond to the input/output images and software data of the module or integrated interface.

Reminders

The module inputs (%I and %IW) are updated in the PLC memory at the start of the task, the PLC being in RUN or STOP mode.

The outputs (%Q and %QW) are updated at the end of the task, only when the PLC is in RUN mode.

NOTE: When the task occurs in STOP mode, either of the following are possible, depending on the configuration selected:

- Outputs are set to fallback position (fallback mode).
- Outputs are maintained at their last value (maintain mode).

Illustration

The operating cycle of a PLC task (cyclical execution) looks like this:

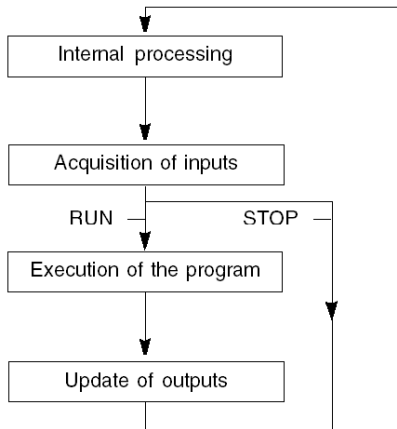

Explicit Exchange Language Objects Associated with Analog Modules

Introduction

Explicit exchanges are performed at the user program's request, using the following instructions:

- `READ_STS`: read status words
- `WRITE_CMD`: write command words
- `WRITE_PARAM`: write adjustment parameters
- `READ_PARAM`: read adjustment parameters
- `SAVE_PARAM`: save adjustment parameters
- `RESTORE_PARAM`: restore adjustment parameters

These exchanges apply to a set of `%MW` objects of the same type (status, commands, or parameters) that belong to a channel.

NOTE: These objects provide information about the module (e.g.: error type for a channel, etc.) and can be used to command them (e.g.: switch command) and to define their operating modes (save and restore currently applied adjustment parameters).

NOTE: You can not send the `WRITE_PARAM` and `RESTORE_PARAM` requests at the same time to the channels managed by the same logical nodes, The logical node can only process one request, the other request will generate an error. To avoid this kind of errors you have to manage the exchange for each channel with `%MWr.m.c.0.x` and `%MWr.m.c.1.x`.

General Principle for Using Explicit Instructions

The diagram below shows the different types of explicit exchanges that can be made between the processor and module.

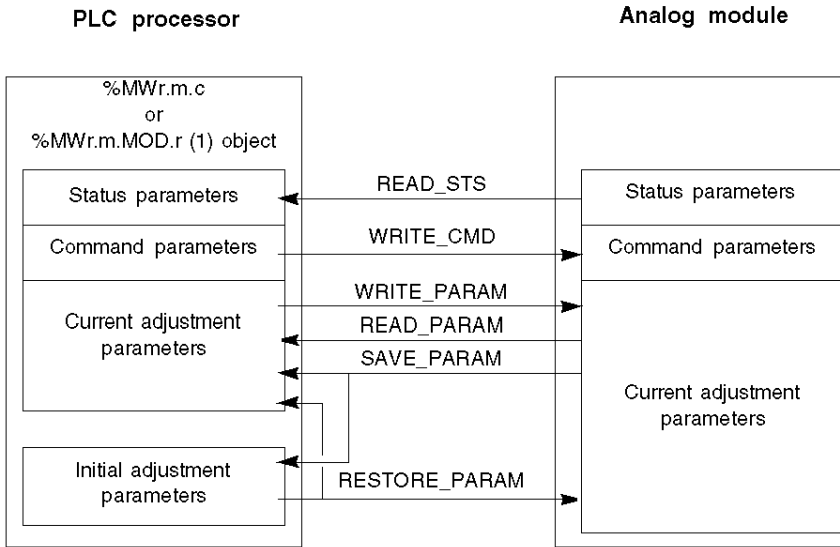

(1) Only with READ_STS and WRITE_CMD instructions.

Example of Using Instructions

READ_STS instruction:

The `READ_STS` instruction is used to read `SENSOR_FLT` (%MWr.m.c.2) and `NOT_READY` (%MWr.m.c.3) words. It is therefore possible to determine with greater precision the errors which may have occurred during operation.

Performing a `READ_STS` of all the channels would result in overloading of the PLC. A less burdensome method would be to test the error bit of all the modules in each cycle, and then the channels of the modules in question. You would then only need to use the `READ_STS` instruction on the address obtained.

The algorithm could look like this:

```
WHILE (%I0.m.ERR <> 1) OR (m <= Number of modules) THEN
    m=m+1
    Loop
END WHILE
```

```
WHILE (%I0.m.c.ERR <> 1) OR (c <= Number of channels) THEN
    c=c+1
    Loop
END WHILE
```

```
READ_STS (%I0.m.c)
```

WRITE_PARAM instruction:

The `WRITE_PARAM` instruction is used to modify certain configuration parameters for the modules during operation.

All you need to do is to assign the new values to the relevant objects and use the `WRITE_PARAM` instruction on the required channel.

For example, you can use this instruction to modify the fallback value by program (only for output analog modules). Assign the required value to the `Fallback` (%MWr.m.c.7) word and then use the `WRITE_PARAM` instruction.

Management of Exchanges and Reports with Explicit Objects

At a Glance

When data is exchanged between the PLC memory and the module, the module may require several task cycles to acknowledge this information. All IODDTs use two words to manage exchanges:

- EXCH_STS (%MWr.m.c.0) : exchange in progress
- EXCH_RPT (%MWr.m.c.1) : report

NOTE: Depending on the localization of the module, the management of the explicit exchanges (%MW0.0.MOD.0.0 for example) will not be detected by the application:

- for in-rack modules, explicit exchanges are done immediately on the local PLC Bus and are finished before the end of the execution task, so the READ_STS, for example, is always finished when the %MW0.0.mod.0.0 bit is checked by the application.
- for remote bus (Fipio for example), explicit exchanges are not synchronous with the execution task, so the detection is possible by the application.

Illustration

The illustration below shows the different significant bits for managing exchanges.

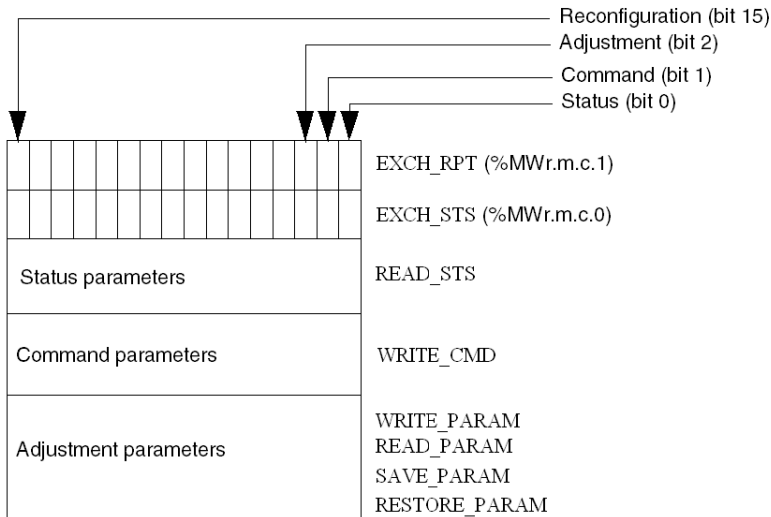

Description of Significant Bits

Each bit of the EXCH_STS (%MWr.m.c.0) and EXCH_RPT (%MWr.m.c.1) words is associated with a type of parameter:

- Rank 0 bits are associated with the status parameters:
 - The STS_IN_PROGR bit (%MWr.m.c.0.0) indicates whether a read request for the status words is in progress.
 - The STS_ERR bit (%MWr.m.c.1.0) specifies whether a read request for the status words is accepted by the module channel.
- Rank 1 bits are associated with the command parameters:
 - The CMD_IN_PROGR bit (%MWr.m.c.0.1) indicates whether command parameters are being sent to the module channel.
 - The CMD_ERR bit (%MWr.m.c.1.1) specifies whether the command parameters are accepted by the module channel.
- Rank 2 bits are associated with the adjustment parameters:
 - The ADJ_IN_PROGR bit (%MWr.m.c.0.2) indicates whether the adjustment parameters are being exchanged with the module channel (via WRITE_PARAM, READ_PARAM, SAVE_PARAM, RESTORE_PARAM).
 - The ADJ_ERR bit (%MWr.m.c.1.2) specifies whether the adjustment parameters are accepted by the module. If the exchange is correctly executed, the bit is set to 0.
- Rank 15 bits indicate a reconfiguration on channel c of the module from the console (modification of the configuration parameters and cold start-up of the channel).
- Bits r, m, and c indicate the following slots:
 - Bit r represents the rack number.
 - Bit m represents the position of the module in the rack.
 - Bit c represents the channel number in the module.

NOTE: Exchange and report words also exist at the level of EXCH_STS (%MWr.m.MOD.0) and EXCH_RPT (%MWr.m.MOD.1) modules, as per T_ANA_IN_BMX, T_ANA_IN_T_BMX and T_ANA_OUT_BMX-type IODDTs.

Example

Phase 1: Sending data by using the `WRITE_PARAM` instruction:

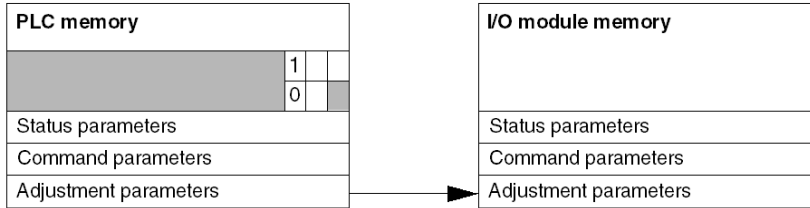

When the instruction is scanned by the PLC processor, the `Exchange in progress` bit is set to 1 in `%MWr.m.c.`

Phase 2: Analysis of the data by the input/output module and report:

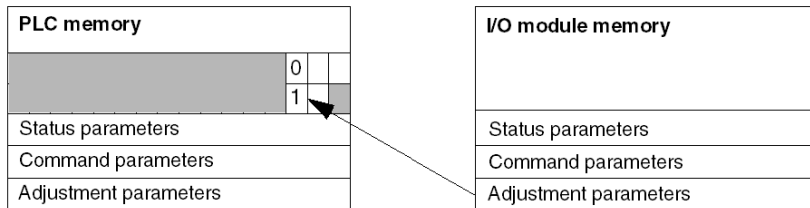

When data is exchanged between the PLC memory and the module, acknowledgement by the module is managed by the `ADJ_ERR (%MWr.m.c.1.2)` bit which, depending on its value, gives the following report:

- **0**: correct exchange.
- **1**: error in exchange.

NOTE: There is no adjustment parameter at module level.

Explicit Exchange Execution Flag: EXCH_STS

The table below shows the EXCH_STS (%MWr.m.c.0) explicit exchange control bits.

Standard symbol	Type	Access	Meaning	Address
STS_IN_PROGR	BOOL	R	Reading of channel status words in progress	%MWr.m.c.0.0
CMD_IN_PROGR	BOOL	R	Command parameters exchange in progress	%MWr.m.c.0.1
ADJ_IN_PROGR	BOOL	R	Adjust parameters exchange in progress	%MWr.m.c.0.2
RECONF_IN_PROGR	BOOL	R	Reconfiguration of the module in progress	%MWr.m.c.0.15

NOTE: If the module is not present or is disconnected, explicit exchange objects (READ_STS, for example) are not sent to the module (STS_IN_PROG (%MWr.m.c.0.0) = 0), but the words are refreshed.

Explicit Exchange Report: EXCH_RPT

The table below presents the EXCH_RPT (%MWr.m.c.1) report bits.

Standard symbol	Type	Access	Meaning	Address
STS_ERR	BOOL	R	Error reading channel status words (1 = error)	%MWr.m.c.1.0
CMD_ERR	BOOL	R	Error during a command parameter exchange (1 = error)	%MWr.m.c.1.1
ADJ_ERR	BOOL	R	Error while exchanging adjustment parameters (1 = error)	%MWr.m.c.1.2
RECONF_ERR	BOOL	R	Error during reconfiguration of the channel (1 = error)	%MWr.m.c.1.15

Language Objects Associated with Configuration

At a Glance

The configuration of an analog module is stored in the configuration constants (%KW).

The parameters r, m, and c shown in the following tables represent the topologic addressing of the module. Each parameter had the following signification:

- **r**: represents the rack number
- **m**: represents the position of the module on the rack
- **c**: represents the channel number

BME AHI 0812, BMX AMI 0410, BMX AMI 0800, and BMX AMI 0810 Configuration Objects and Inputs of BMX AMM 0600

The process control language objects associated to the configuration of the BME AHI 0812, BMX AMI 0410, BMX AMI 0800, and BMX AMI 0810 modules include the following:

Addresses	Description	Bits Meaning
%KW.r.m.c.0	Channel range configuration	Bit 0 to 5 : electric range (hexadecimal value) Bit 7 : 0=electrical range (always 0)
%KW.r.m.c.1	Scale/User scaling min value	-
%KW.r.m.c.2	Scale/User scaling max value	-
%KW.r.m.c.3	Over range below value	-
%KW.r.m.c.4	Over range above value	-
%KW.r.m.c.5	Channel treatment configuration	Bit 0 : 0=Mast mode, 1=Fast mode Bit 1 : 0=channel disabled, 1=channel enabled Bit 2 : 0=sensor monitor off, 1=sensor monitor on Bit 7 : 0=Manufacturer scale, 1=user scale Bit 8 : over range lower threshold enabled Bit 9 : over range upper threshold enabled

BMX ART 0414/0814 Configuration Objects

The process control language objects associated to the configuration of the BMX ART 0414/0814 modules include the following:

Addresses	Description	Bits Meaning
%KWr.m.c.0	Channel range configuration	Bit 0 to 5: Temperature range (hexadecimal value) Bit 6: Temperature range (0=°C, 1=F°) Bit 7: 1=Temperature range Bit 8: 0=rejection 50 Hz, 1=rejection 60 Hz
%KWr.m.c.1	Scale/User scaling min value	-
%KWr.m.c.2	Scale/User scaling max value	-
%KWr.m.c.3	Over range below value	-
%KWr.m.c.4	Over range above value	-
%KWr.m.c.5	Channel treatment configuration	Bit 0: 0=Standard mode (always 0) Bit 1: 0=channel disabled (only in Fast mode), 1=channel enabled Bit 2: 0=sensor monitor off, 1=sensor monitor on Bits 3 to 6: CJC Configuration Mode for channels 0/3: <ul style="list-style-type: none"> ● Bit 3=0 and Bit 4=0: Int. Telefast, ● Bit 3=1 and Bit 4=0: External RTD, ● Bit 3=0 and Bit 4=1: CJC on channels 4/7. Bits 3 to 6: CJC Configuration Mode for channels 4/7: <ul style="list-style-type: none"> ● Bit 5=0 and Bit 6=0: Int. Telefast, ● Bit 5=1 and Bit 6=0: External RTD. Bit 7: 0=Manufacturer scale, 1=user scale Bit 8: Over range lower threshold enabled Bit 9: Over range upper threshold enabled

BME AHO 0412, BMX AMO 0210, BMX AMO 0410, and BMX AMO 0802 Configuration Objects and Outputs of BMX AMM 0600

The process control language objects associated to the configuration of the BME AHO 0412, BMX AMO 0210, BMX AMO 0410, and BMX AMO 0802 modules include the following:

Addresses	Description	Bits Meaning
%KWr.m.c.0	Channel range configuration	Bit 0 to 5: Electric range (hexadecimal value) Bit 8: Fallback mode (0=Fallback, 1=Maintain) Bit 11: Actuator wiring control (0=disabled, 1=enabled) Bit 14: Output lower overshoot below range valid (0=disabled, 1=enabled) Bit 15: Output upper overshoot above range valid (0=disabled, 1=enabled)
%KWr.m.c.1	Scale/User scaling min value	-
%KWr.m.c.2	Scale/User scaling max value	-
%KWr.m.c.3	Overshoot below value	-
%KWr.m.c.4	Overshoot above value	-

Part III

Quick Start: Example of Analog I/O Module Implementation

In this Part

This part presents an example of implementation of the analog input/output modules.

What Is in This Part?

This part contains the following chapters:

Chapter	Chapter Name	Page
17	Description of the Application	303
18	Installing the Application Using Unity Pro	305
19	Starting the Application	335
20	Actions and transitions	345

Chapter 17

Description of the Application

Overview of the Application

At a Glance

The application described in this document is used to manage the level of a liquid in a tank. The tank is filled by a pump, and drained using a valve.

The level of the tank is measured with an ultrasonic sensor placed below of the tank.

The volume of the tank is shown by a digital display.

The desired level of liquid is defined by the operator, using a potentiometer

The application's operation control resources are based on an operator screen, which shows the status of the various sensors and actuators, as well as the level of the tank.

The high tank level is defined through the operator screen.

Illustration

This is the application's final operator screen:

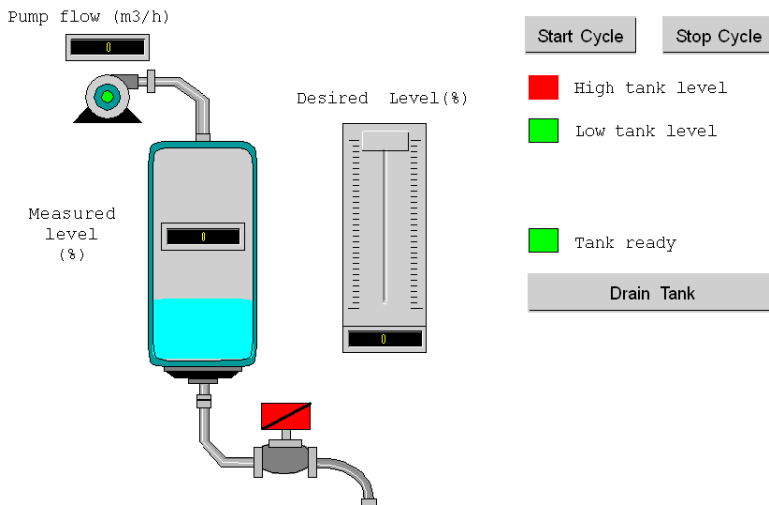

Operating Mode

The operating mode is as follows:

- A potentiometer is used to defined the desired level.
- A **Start Cycle** button is used to start the filling.
- When the desired level of the tank is reached, the pump stops and the **Tank ready** led lights up.
- A **Drain tank** button is used to start the tank draining.
- When the low level of the tank is reached, the valve closes. The **Start Cycle** button is used to restart the filling.
- A **Stop Cycle** button is used to interrupt the filling. Pressing this button allows you to set the system to a safe level. The pump stops and the valve opens until the low level is reached (tank empty). The valve closes.
- The pump has a variable flow rate, the value of which can be accessed by the operator screen. The more the level of liquid is raised, the more the flow is reduced. The flow rate of the valve is fixed.
- A safety measure must be installed. If the high level is exceeded, a safety measure is activated and the system is set to failsafe. The pump then stops and the valve opens until the low level is reached (tank empty). The valve closes.
- For failsafe mode, an error message must be displayed.
- The time that the valve is open and closed is monitored, with an error message being displayed if either of these is exceeded.

Chapter 18

Installing the Application Using Unity Pro

Subject of this Chapter

This chapter describes the procedure for creating the application described. It shows, in general and in more detail, the steps in creating the different components of the application.

What Is in This Chapter?

This chapter contains the following sections:

Section	Topic	Page
18.1	Presentation of the Solution Used	306
18.2	Developing the Application	310

Section 18.1

Presentation of the Solution Used

Subject of this Section

This section presents the solution used to develop the application. It explains the technological choices and gives the application's creation timeline.

What Is in This Section?

This section contains the following topics:

Topic	Page
Technological Choices Used	307
The Different Steps in the Process Using Unity Pro	308

Technological Choices Used

At a Glance

There are several ways of writing an application using Unity Pro. The one proposed allows you to structure the application so as to facilitate its creation and debugging.

Technological Choices

The following table shows the technological choices used for the application.

Objects	Choices used
Use of the pump	Creation of a user function block (DFB) to facilitate management of the pump in terms of entering a program and speed of debugging. The programming language used to develop this DFB is a function block diagram (FBD)-based graphic language.
Use of the valve	Creation of a user function block (DFB) to facilitate management of the valve in terms of entering a program and speed of debugging. The programming language used to develop this DFB is a function block diagram (FBD)-based graphic language.
Supervision screen	Use of elements from the library and new objects.
Main supervision program	This program is developed using a sequential function chart (SFC), also called GRAFCET. The various sections are created in Ladder Diagram (LD) language, and use the different DFBs created.
Fault display	Use of the ALRM_DIA DFB to control the status of the variables linked with the detected errors.

NOTE: Using a DFB function block in an application enables you to:

- simplify the design and entry of the program
- increase the legibility of the program
- facilitate debugging the application
- reduce the volume of generated code

The Different Steps in the Process Using Unity Pro

At a Glance

The following logic diagram shows the different steps to follow to create the application. A chronological order must be respected in order to correctly define all of the application elements.

Description

Description of the different types:

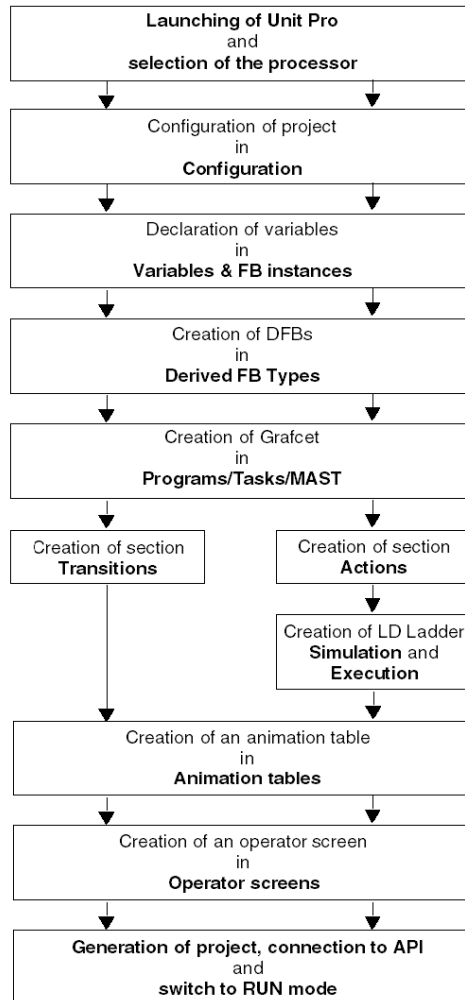

Section 18.2

Developing the Application

Subject of this Section

This section gives a step-by-step description of how to create the application using Unity Pro.

What Is in This Section?

This section contains the following topics:

Topic	Page
Creating the Project	311
Selection of the Analog Module	312
Declaration of Variables	313
Creation and Use of the DFBs	316
Creating the Program in SFC for Managing the Tank	321
Creating a Program in LD for Application Execution	325
Creating a Program in LD for Application Simulation	327
Creating an Animation Table	330
Creating the Operator Screen	331

Creating the Project

At a Glance

Developing an application using Unity Pro involves creating a project associated with a PLC.

Procedure for Creating a Project

The table below shows the procedure for creating the project using Unity Pro.

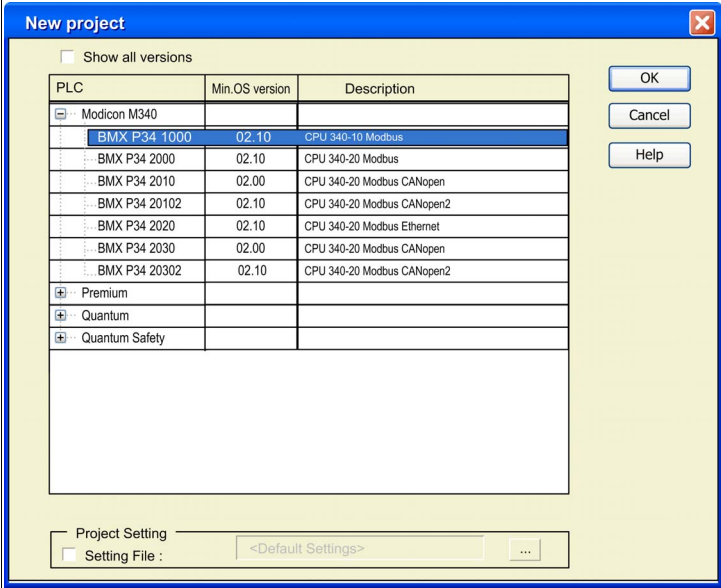
Etape	Action
1	Launch the Unity Pro software.
2	Click File then New to select a PLC. 
3	To see all PLC versions, click on the box Show all versions.
4	Select the processor you wish to use from those proposed.
5	To create a project with specific values of project settings, check the box Settings File and use the browser button to localize the .XSO file (Project Settings file). It is also possible to create a new one. If the Settings File box is not checked, default values of project settings are used.
6	Confirm with OK.

Selection of the Analog Module

At a Glance

Developing an analog application involves choosing the right module and appropriate configuration.

Module Selection

The table below shows the procedure for selecting the analog module.

Step	Action
1	In the Project browser double-click Configuration, 0:PLC bus, 0:BMX (Where 0 is the rack number) and double-click a slot.
2	In the Hardware Catalog window, select the BMX AMI 0410 input module then drag and drop it in the PLC bus window. <div data-bbox="290 630 861 1122" data-label="Image"> <p>The screenshot shows a 'Hardware catalog' window with a tree view. The 'Analog' category is expanded, showing a list of modules: BMX AMI 0410, BMX AMI 0800, BMX AMI 0810, BMX AMM 0600, BMX AMO 0210, BMX AMO 0410, BMX AMO 0802, BMX ART 0414, and BMX ART 0814. Below the tree are categories: Communication, Counting, Discrete, Motion, Rack, and Supply. At the bottom, there are navigation buttons and tabs for 'CANopen', 'PLC bus', and 'DTM catalog'.</p> </div>
3	Do the same for the BMX AMO 0210 output module.

Declaration of Variables

At a Glance

All of the variables used in the different sections of the program must be declared.

Undeclared variables cannot be used in the program.

NOTE: For more information, see Unity Pro online help (click on [?](#), then [Unity](#), then [Unity Pro](#), then [Operate modes](#), and [Data editor](#)).

Procedure for Declaring Variables

The table below shows the procedure for declaring application variables.

Step	Action
1	In Project browser / Variables & FB instances, double-click on Elementary variables
2	In the Data editor window, select the box in the Name column and enter a name for your first variable.
3	Now select a Type for this variable.
4	When all your variables are declared, you can close the window.

Variables Used for the Application

The following table shows the details of the variables used in the application.

Variable	Type	Definition
Acknowledgement	EBOOL	Acknowledgement of an error (Status 1).
Stop	EBOOL	Stop cycle at end of draining (Status 1).
Valve_Opening_Cmd	EBOOL	Opening of the valve (Status 1).
Motor_Run_Cmd	EBOOL	Startup request for filling cycles (Status 1).
Valve_Closing_Cmd	EBOOL	Closing of the valve (Status 1).
Initiale_condition	EBOOL	Transition that starts the pump.
Desired_Level	REAL	Desired level of liquid.
Tank_ready	BOOL	Tank is full, ready to be drained.
Flow	BOOL	Intermediate variable for simulating the application.
Init_Flow	REAL	Pump initial flow rate.
Flow_Reduction	BOOL	Pump flow rate after reduction.
Pump_Flow	REAL	Pump flow rate.
Valve_Flow	REAL	Valve flow rate.
Motor_Error	EBOOL	Error returned by the motor.

Variable	Type	Definition
Valve_Closure_Error	EBOOL	Error returned by the valve on closing.
Valve_Opening_Error	EBOOL	Error returned by the valve on opening.
Lim_Valve_Closure	EBOOL	Valve in closed position (Status 1).
Lim_Valve_Opening	EBOOL	Valve in opened position (Status 1)
Run	EBOOL	Startup request for filling cycles (Status 1).
Nb_Stage	REAL	Number of tank filling stage.
Level	REAL	Level of liquid in the tank.
Tank_low_level	EBOOL	Tank volume at low level (Status 1).
Tank_high_level	EBOOL	Tank volume at high level (Status 1).
Stage	REAL	Stage incrementation value.
Contactor_Return	EBOOL	Error returned by the contactor in the event of motor error.
Valve_closure_time	TIME	Valve closure time.
Valve_opening_time	TIME	Valve opening time.
Drain	EBOOL	Drain command

NOTE: EBOOL types can be used for I/O modules, unlike BOOL types.

The following screen shows the application variables created using the data editor:



The screenshot shows the 'Data Editor' window with a table of variables. The table has columns for Name, Type, Address, Value, and Comment. The variables listed include Acknowledgement, Contactor_Return, Desired_Level, Drain, Flow, Flow_Reduction, Initiale_Condition, Init_Flow, Level, Lim_Valve_Closure, Lim_Valve_Opening, Motor_Error, Motor_Run_Cmd, Nb_Stage, Pump_Flow, Run, Stage, Stop, Tank_Low_Level, Tank_High_Level, Tank_Ready, Valve_Closure_Cmd, Valve_Closure_Error, Valve_Closure_Time, Valve_Flow, Valve_Opening_Cmd, Valve_Opening_Error, and Valve_Opening_Time. The 'Value' column contains numerical values for several variables: Init_Flow (1), Nb_Stage (10), Pump_Flow (0.0), Stage (0.0), and Valve_Flow (1.0).

Name	Type	Adresse...	Value	Comment
Acknowledgement	EBOOL			
Contactor_Return	EBOOL			
Desired_Level	REAL			
Drain	EBOOL			
Flow	BOOL			
Flow_Reduction	BOOL			
Initiale_Condition	EBOOL			
Init_Flow	REAL		1	
Level	REAL			
Lim_Valve_Closure	EBOOL			
Lim_Valve_Opening	EBOOL			
Motor_Error	EBOOL			
Motor_Run_Cmd	EBOOL			
Nb_Stage	REAL		10	
Pump_Flow	REAL		0.0	
Run	EBOOL			
Stage	REAL		0.0	
Stop	EBOOL			
Tank_Low_Level	EBOOL			
Tank_High_Level	EBOOL			
Tank_Ready	BOOL			
Valve_Closure_Cmd	EBOOL			
Valve_Closure_Error	EBOOL			
Valve_Closure_Time	TIME			
Valve_Flow	REAL		1.0	
Valve_Opening_Cmd	EBOOL			
Valve_Opening_Error	EBOOL			
Valve_Opening_Time	TIME			

Creation and Use of the DFBs

At a Glance

DFB types are function blocks that can be programmed by the user ST, IL, LD or FBD. Our example uses a motor DFB and a valve DFB.

We will also be using existing DFB from the library for monitoring variables. Particularly "safety" variables for tank levels, and "error" variables returned by the valve. The status of these variables will be visible in Diagnostics display.

NOTE: Function blocks can be used to structure and optimize your application. They can be used whenever a program sequence is repeated several times in your application, or to set a standard programming operation (for example, an algorithm that controls a motor).

Once the DFB type is created, you can define an instance of this DFB via the variable editor or when the function is called in the program editor.

NOTE: For more information, see Unity Pro online help (click on [?](#), then [Unity](#), then [Unity Pro](#), then [Language references](#), and [User function block](#)

Procedure for Creating a DFB

The table below shows the procedure for creating application DFBs.

Step	Action
1	In the <code>Project browser</code> , right click on <code>Derived FB types</code> and select <code>Open</code> .
2	In the <code>Data editor</code> window, select the box in the <code>Name</code> column and enter a name for your DFB and confirm with <code>Enter</code> . The name of your DFB appears with the sign "Works" (unanalyzed DFB).
3	Open the structure of your DFB (see figure next page) and add the inputs, outputs and other variables specific to your DFB.
4	When the variables of the DFB are declared, analyze your DFB (the sign "Works" must disappear). To analyze your DFB, select the DFB and, in the menu, click <code>Build</code> then <code>Analyze</code> . You have created the variables for your DFB, and must now create the associated section.
5	In the <code>Project browser</code> , double-click on <code>Derived FB types</code> then on your DFB. Under the name of your DFB, the <code>Sections</code> field will appear.
6	Right click on <code>Sections</code> then select <code>New section</code> .
7	Give your section a name, then select the language type and confirm with <code>OK</code> . Edit your section using the variables declared in step 3. Your DFB can now be used by the program (DFB Instance).

Variables Used by the Motor DFB

The following table lists the variables used by the Motor DFB.

Variable	Type	Definition
Run	Input	Motor run command.
Stop	Input	Motor stop command.
Contactactor_Return	Input	Contactactor feedback in the event of motor run problem.
Acknowledgement	Input	Acknowledgement of the Motor_error output variable.
Motor_Run_Cmd	Output	Start of motor.
Motor_Error	Output	Display in the "Diagnostics display" window of an alarm linked to a problem with the motor.

Illustration of the Motor DFB Variables Declared in the Data Editor

The following screen shows the Motor DFB variables used in this application to control the motor.

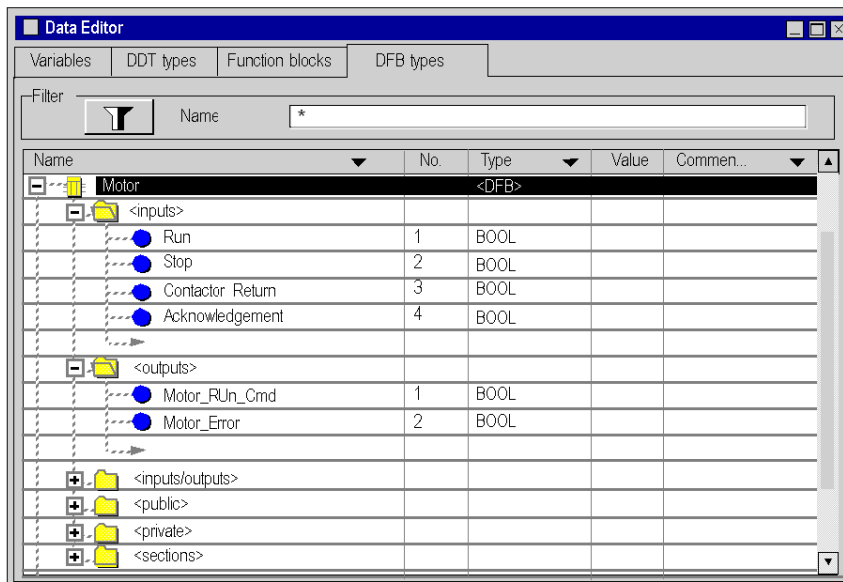

Operating Principle of the Motor DFB

The following screen shows the Motor DFB program written by the application in FBD for controlling the motor.

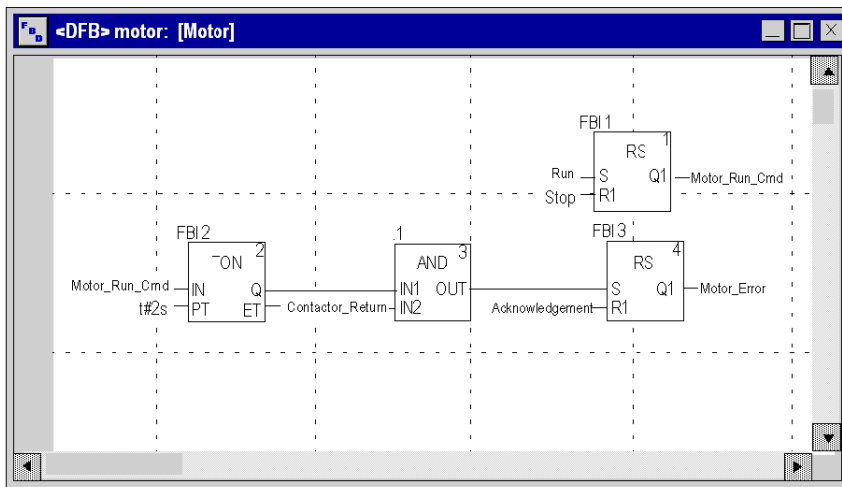

When Run = 1 and Stop = 0, the motor can be controlled (Motor_Run_Cmd = 1). The other part monitors the Contactor_return variable. If Contactor_return is not set to "1" after the Discrete counter counts two seconds, the Motor_error output switches to "1".

NOTE: Note: For more information on creating a section, consult the Unity Pro online help (click ?, then Unity, then Unity Pro, then Operate Modes and Programming and select the required language).

Variables Used by the Valve DFB

The following table lists the variables used by the Valve DFB.

Variable	Type	Definition
Valve_opening	Input	Valve opening command.
Valve_closure	Input	Valve closure command.
Lim_valve_opening	Input	Status of valve limit.
Lim_valve_closure	Input	Status of valve limit.
Acknowledgement	Input	Acknowledgement of variables Valve_closure_error or Valve_opening_error.
Valve_opening_cmd	Output	Opening of the valve.
Valve_closure_cmd	Output	Closure of the valve.

Variable	Type	Definition
Valve_opening_error	Output	Display in the "Diagnostics display" window of an alarm linked to a problem with the valve opening.
Valve_closure_error	Output	Display in the "Diagnostics display" window of an alarm linked to a problem with the valve closure.

Illustration of the Valve DFB Variables Declared in the Data Editor

The following screen shows the Valve DFB variables used in this application to control the valve.

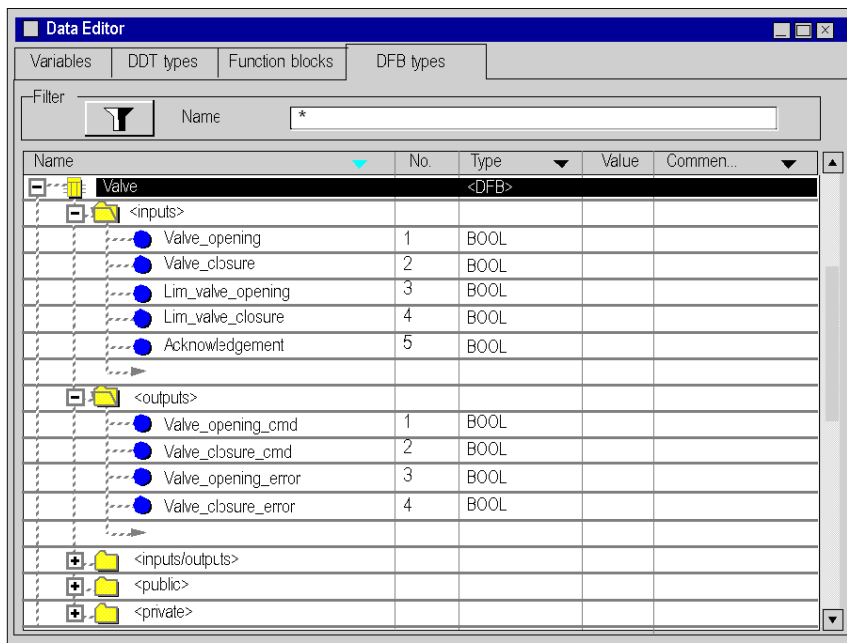

Operating Principle of the Valve DFB

The following screen shows the Valve DFB written in FBD language.

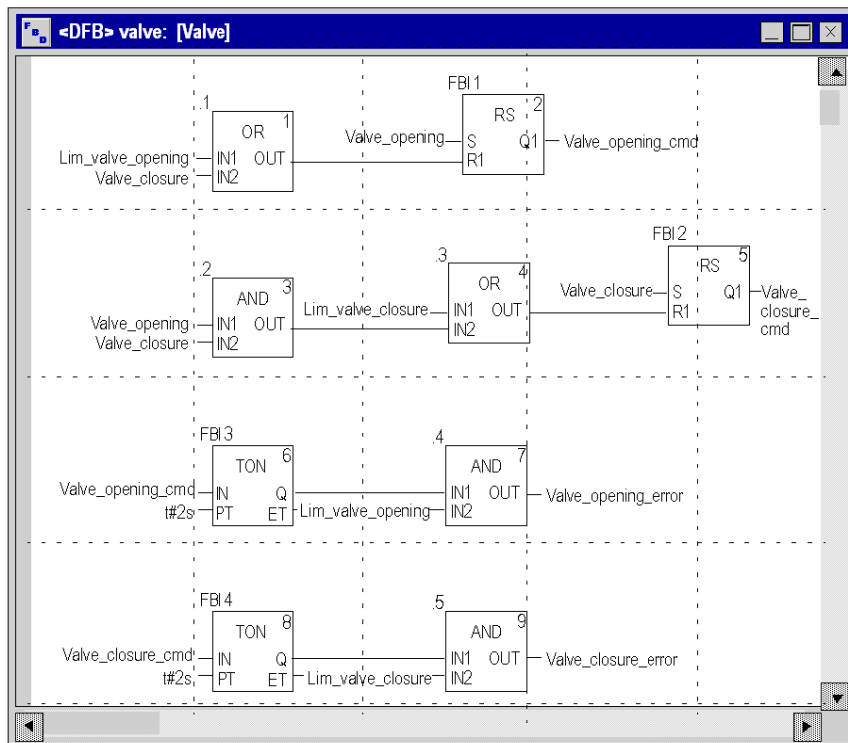

This DFB authorizes the command to open the valve (Valve_opening_cmd) when the inputs Valve_closure and Lim_valve_opening are set to "0". The principle is the same for closure, with an additional safety feature if the user requests the opening and closing of the valve at the same time (opening takes priority).

In order to monitor opening and closing times, we use the TON timer to delay the triggering of an error condition. Once the valve opening is enabled (Valve_opening_cmd = 1), the timer is triggered. If Lim_valve_opening does not switch to "1" within two seconds, the output variable Valve_opening_error switches to "1". In this case a message is displayed.

NOTE: The PT time must be adjusted according to your equipment.

NOTE: For more information on creating a section, consult the Unity Pro online help (click ?, then Unity, then Unity Pro, then Operate Modes and Programming and select the required language).

Creating the Program in SFC for Managing the Tank

At a Glance

The main program is written in SFC (Grafcet). The different sections of the grafcet steps and transitions are written in LD. This program is declared in a MAST task, and will depend on the status of a Boolean variable.

The main advantage of SFC language is that its graphic animation allows us to monitor in real time the execution of an application.

Several sections are declared in the MAST task:

- The **Tank_management** (See *Illustration of the Tank_management Section*, [page 322](#)) section, written in SFC and describing the operate mode,
- The **Execution** (See *Creating a Program in LD for Application Execution*, [page 325](#)) section, written in LD, which executes the pump start-up using the motor DFB, as well as the opening and closure of the valve.
- The **Simulation** (See *Creating a Program in LD for Application Simulation*, [page 327](#)) section, written in LD, which simulates the application. This section must be deleted in the case of connection to a PLC.

NOTE: The LD, SFC and FBD-type sections used in the application must be animated in online mode (See *Starting the Application*, [page 335](#)), with the PLC in RUN

Illustration of the Tank_management Section

The following screen shows the application Grafcet:

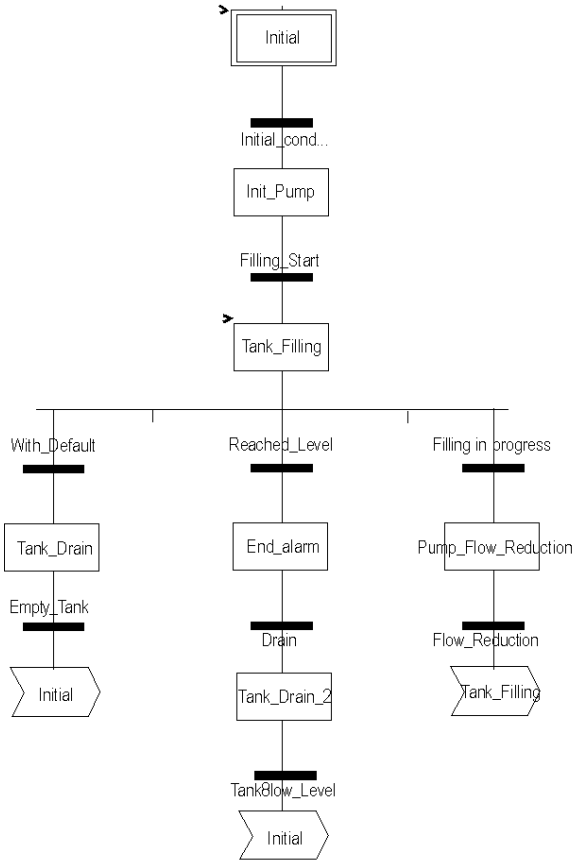

For actions and transitions used in the grafcet, see *Actions and transitions, page 345*

NOTE: For more information on creating an SFC section, see Unity Pro online help (click on ?, then Unity, then Unity Pro, then Operate modes, then Programming and SFC editor.

Description of the Tank_management Section



The following table describes the different steps and transitions of the Tank_management Grafcet:

Step / Transition	Description
Initial	This is the initial step.
Initial_condition	This is the transition that starts the pump. The transition is valid when the variables: <ul style="list-style-type: none"> ● Stop = 0, ● Run = 1, ● Tank_High_Level = 0, ● Lim_valve_closure = 1 ● Desired_Level > 0
Init_Pump	This is the step initiate the pump flow rate.
Filling_Start	This transition is active when the pump flow rate is initialized.
Tank_Filling	This is the step that starts the pump and filling of the tank until the high level is reached. This step activates the motor DFB in the Application section, which controls the activation of the pump.
Reached_Level	This transition is active when the tank's desired level is reached.
End_Alarm	This is the step that lights the Tank ready led
Drain	This transition is active when the operator click on the Drain Tank button (Drain = 1).
Tank_Drain_2	This step is identical to Tank_Drain.
Tank_Low_Level	This transition is active when the low level of the tank is reached (Tank_Low_Level = 1).
With_fault	This transition is active when High_Safety_Alarm = 1 or the Stop_cycle button has been activated (Stop_cycle = 1).
Tank_Drain	This step activates the valve DFB in the Application section, which controls the opening of the valve.
Empty_Tank	This transition is valid when the tank is empty (Tank_Low_Level = 1 and Pump_Flow = 0.0).
Filling in progress	This transition is valid when the filling of the tank is in progress.
Pump_Flow_Reduction	This is the step that reduces the pump flow rate.
Flow_Reduction	This is the value of the flow rate after reduction.

NOTE: You can see all the steps and actions and transitions of your SFC by clicking on  in front of the name of your SFC section.

Procedure for Creating an SFC Section

The table below shows the procedure for creating an SFC section for the application.

Step	Action
1	In <code>Project Browser\Program\Tasks</code> , double-click on <code>MAST</code> .
2	Right click on <code>Section</code> then select <code>New section</code> . Give your section a name (<code>Tank_management</code> for the SFC section) then select SFC language.
3	The name of your section appears, and can now be edited by double clicking on it.
4	The SFC edit tools appear in the window, which you can use to create your Grafcet. For example, to create a step with a transition: <ul style="list-style-type: none">• To create the step, click on  then place it in the editor,• To create the transition, click on  then place it in the editor (generally under the preceding step).

Creating a Program in LD for Application Execution

At a Glance

This section controls the pump and the valve using the DFBs created (See *Creation and Use of the DFBs*, page 316) earlier.

Illustration of the Execution Section

The section below is part of the MAST task. It has no temporary condition defined for it so it is permanently executed.

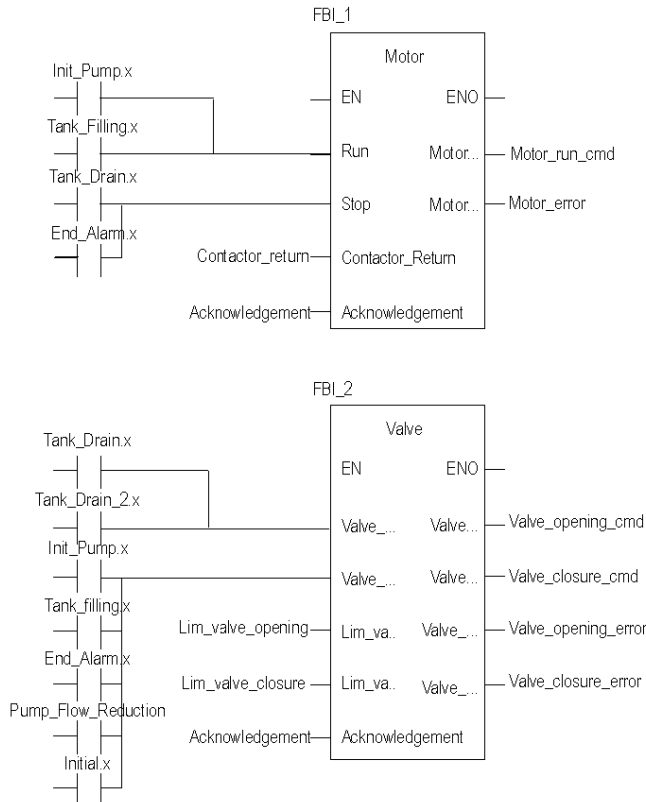



Description of the Application Section

When the Pump step is active, the Run input of the motor DFB is at 1. The `Motor_run_cmd` switches to "1" and the pump supply is activated.

The same principle applies to the rest of the section.

Procedure for Creating an LD Section

The table below describes the procedure for creating part of the **Application** section.

Step	Action
1	In <code>Project Browser\Program\Tasks</code> , double-click on <code>MAST</code> .
2	Right click on <code>Section</code> then select <code>New section</code> . Name this section <code>Application</code> , then select the language type <code>LD</code> . The edit window opens.
3	To create the contact <code>Init_Pump.x</code> , click on  then place it in the editor. Double-click on this contact then enter the name of the step with the suffix ".x" at the end (signifying a step of an SFC section) and confirm with <code>OK</code> .
4	To use the motor DFB you must instantiate it. Right click in the editor then click on <code>Select data</code> and on  . Click on the <code>Function</code> and <code>Function Block Types</code> tab and select your DFB then confirm with <code>OK</code> and position your DFB. To link the <code>Open_valve1.x</code> contact to the stop input of the DFB, align the contact and the input horizontally, click on  and position the link between the contact and the input.

NOTE: For more information on creating an LD section, see Unity Pro online help (click on `?`, then `Unity`, then `Unity Pro`, then `Operate modes`, then `Programming and LD editor`).

Creating a Program in LD for Application Simulation

At a Glance

This section is only used for application simulation. It should therefore not be used if a PLC is connected.

Illustration of the Simulation Section

The section below is part of the MAST task. It has no condition defined for it so it is permanently executed:

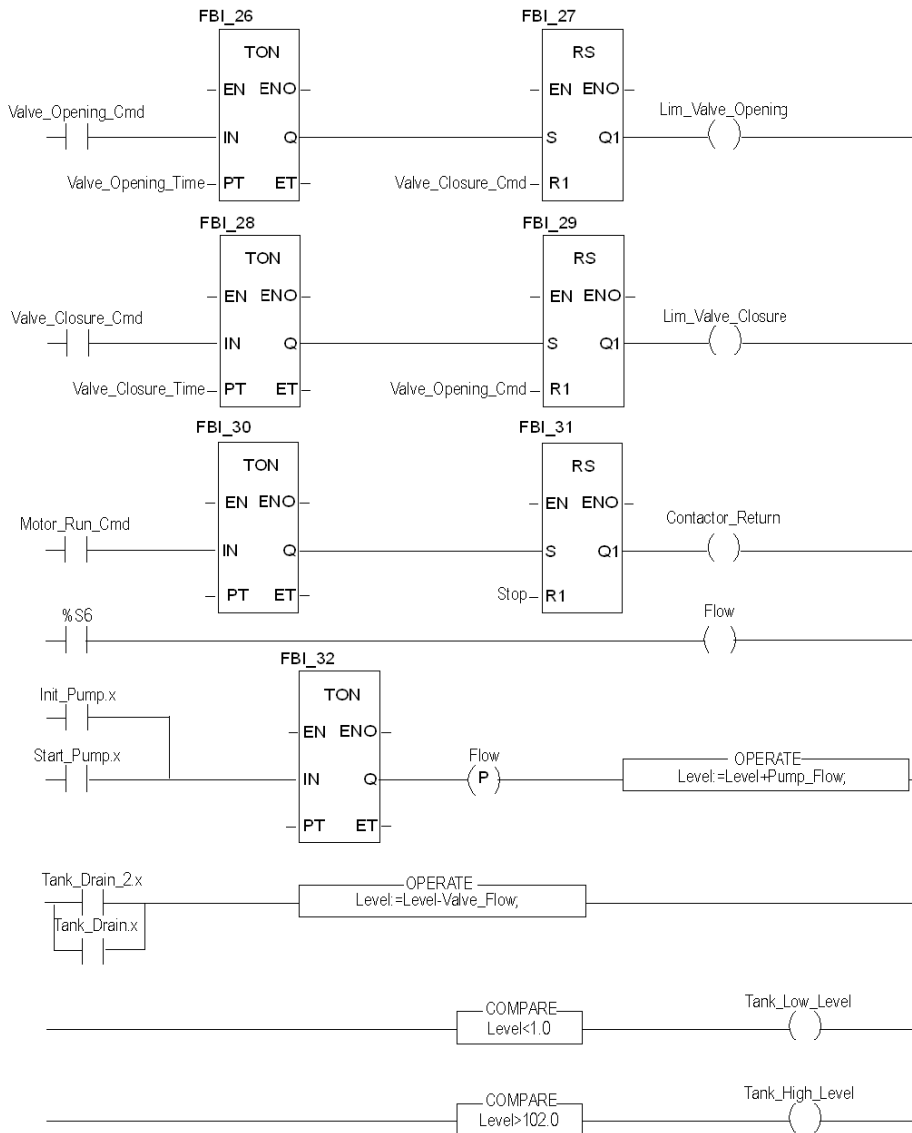

NOTE: For more information on creating an LD section, see Unity Pro online help (click on ?, then Unity, then SoftwareUnity Pro, then Operate modes , then Programming and LD editor).

Description of the Simulation Section

- The first line of the illustration is used to simulate the value of the `Lim_valve_opening` variable. If the valve opening command is given (`Valve_opening_cmd = 1`), a TON timer is triggered. When the PT time is reached, the TON output switches to "1" and increments the `Lim_valve_opening` output to "1" unless the valve closure command is given at the same time.
- Same principle applies to the `Lim_valve_closure` and `Contactactor_return` outputs.
- The last part of the section is used for the simulation of the tank level and for triggering the different tank levels. The OPERATE and COMPARE blocks from the library can be used to do this.

Creating an Animation Table

At a Glance

An animation table is used to monitor the values of variables, and modify and/or force these values. Only those variables declared in `Variables` & `FB` instances can be added to the animation table.

NOTE: For more information, consult the Unity Pro online help (click `?`, then `Unity`, then `Unity Pro`, then `Operate modes`, then `Debugging and adjustment` then `Viewing and adjusting variables and Animation tables`).

Procedure for Creating an Animation Table

The table below shows the procedure for creating an animation table.

Step	Action
1	In the <code>Project</code> browser, right click on <code>Animation tables</code> . The edit window opens.
2	Click on first cell in the <code>Name</code> column, then on the button, and add the variables you require.

Animation Table Created for the Application

The following screen shows the animation table used by the application:

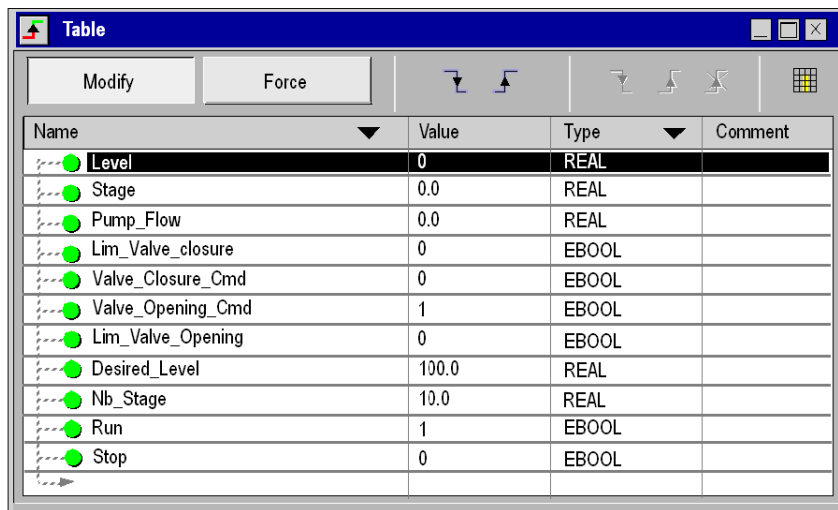

Name	Value	Type	Comment
Level	0	REAL	
Stage	0.0	REAL	
Pump_Flow	0.0	REAL	
Lim_Valve_closure	0	EBOOL	
Valve_Closure_Cmd	0	EBOOL	
Valve_Opening_Cmd	1	EBOOL	
Lim_Valve_Opening	0	EBOOL	
Desired_Level	100.0	REAL	
Nb_Stage	10.0	REAL	
Run	1	EBOOL	
Stop	0	EBOOL	

NOTE: The animation table is dynamic only in online mode (display of variable values).

Creating the Operator Screen

At a Glance

The operator screen is used to animate graphic objects that symbolize the application. These objects can belong to the Unity Pro library, or can be created using the graphic editor.

NOTE: For more information, see Unity Pro online help (click on [?](#), then [Unity](#), then [Unity Pro](#), then [Operate modes](#), and [Operator screens](#)).

Illustration of the Operator Screen

The following illustration shows the application operator screen:

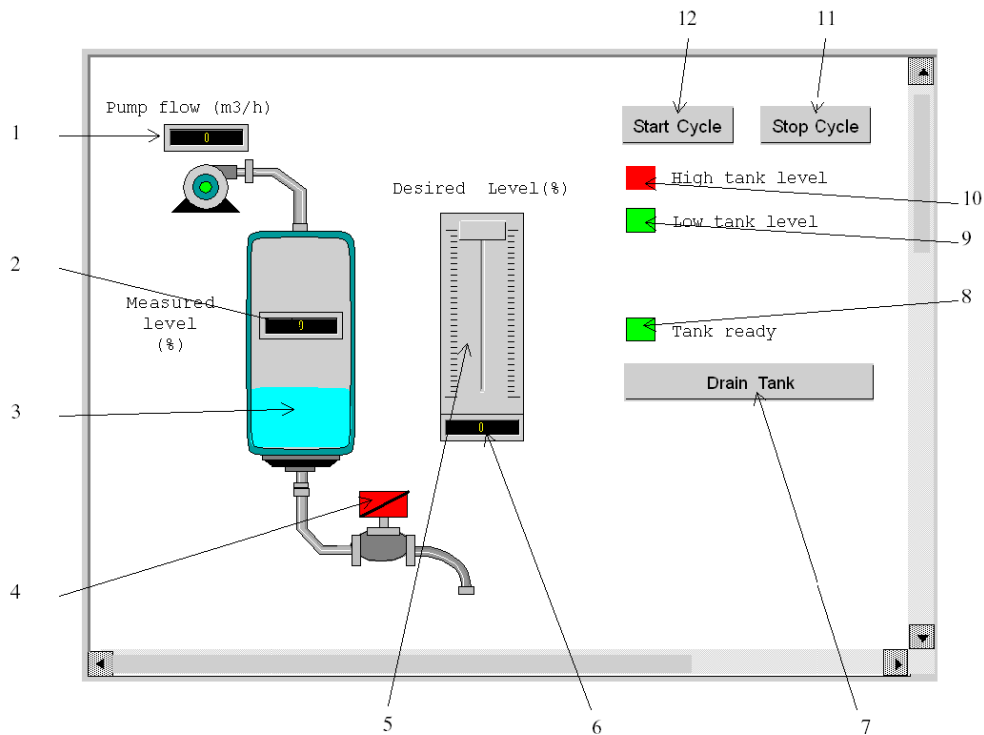





The associated variables are presented in the table below:

N°	Description	Associated variable
1	Pump flow indicator	Pump_Flow
2	Mesured level indicator	Level
3	Representation of the level in the tank	Level
4	Valve	Lim_Valve_Closure
5	Scale indicator	Desired_Level
6	Desired level indicator	Desired_Level
7	Tank Draining button	Drain
8	"Tank ready" indicator light	Tank_Ready
9	"Low tank level" indicator light	Tank_Low_Level
10	"High tank level" indicator light	Tank_High_Level
11	Stop button	Stop
12	Start button	Run



NOTE: To animate objects in online mode, you must click on  . By clicking on this button, you can validate what is written.

Procedure for Creating an Operator Screen

The table below shows the procedure for inserting and animating the tank.

Step	Action
1	In the <code>Project</code> browser, right click on <code>Operator</code> screens and click on <code>New</code> screen. The operator screen editor appears.
2	<ul style="list-style-type: none"> In the <code>Tools</code> menu, select <code>Operator Screen Library</code>. The window opens. Double click on <code>Fluids</code> then <code>Tank</code>. Select the dynamic tank from the runtime screen, and <code>Copy</code> (Ctrl + C) then <code>Paste</code> (Ctrl + V) it into the drawing in the operator screen editor (to return to your screen, click on <code>Window</code> then <code>Screen</code>). The tank is now in your operator screen. You now need a variable to animate the level. In the <code>Tools</code> menu, click on <code>Variables Window</code>. The window appears to the left, and in the <code>Name</code> column we see the word <code>%MW0</code>. To obtain the animated part of the graphic object (in this case the tank), double click on <code>%MW0</code>. A part of the tank is selected. Right click on this part, then click on <code>Characteristics</code>. Select the <code>Animation</code> tab and enter the  variable concerned by clicking the  button (in the place of <code>%MW0</code>). In our application, this will be <code>Tank_vol</code>. You must define the tank's minimum and maximum values. In the <code>Type of</code>  animation tab, click <code>Bar chart</code> then the  button, and fill in the entry fields according to the tank. Confirm with <code>Apply</code> and <code>OK</code>.
3	Click on  to select the other lines one by one and apply the same procedure.

The table below shows the procedure for creating the Start button.

Step	Action
1	In the <code>Project</code> browser, right click on <code>Operator</code> screens and click on <code>New</code> screen. The operator screen editor appears.
2	Click on the  and position the new button on the operator screen. Double click on the button and in the <code>Control</code> tab, select the <code>Run</code> variable by clicking the  button and confirm with <code>OK</code> . Then, enter the button name in the text zone.

NOTE: In the `Instance Selection`, tick the `IODDT` checkbox and click on  to access the I/O objects list.

Chapter 19

Starting the Application

Subject of this Chapter

This chapter shows the procedure for starting the application. It describes the different types of application executions.

What Is in This Chapter?

This chapter contains the following topics:

Topic	Page
Execution of Application in Simulation Mode	336
Execution of Application in Standard Mode	337

Execution of Application in Simulation Mode

At a Glance

You can connect to the API simulator which enables you to test an application without a physical connection to the PLC and other devices.

NOTE: For more information, see Unity Pro online help (click on **?**, then **Unity**, then **Unity Pro**, then **Operate modes**, then **Debugging and adjustment and PLC simulator**).

Application Execution

The table below shows the procedure for launching the application in simulation mode:

Step	Action
1	In the PLC menu, click on Simulation Mode ,
2	In the Build menu, click on Rebuild All Project . Your project is generated and is ready to be transferred to the simulator. When you generate the project, you will see a results window. If there is an error in the program, Unity Pro indicates its location if you double-click on the highlighted sequence.
3	In the PLC menu, click on Connection . You are now connected to the simulator.
4	In the PLC menu, click on Transfer project to PLC . The Transfer project to PLC window opens. Click on Transfer . The application is transferred to the PLC simulator.
5	In the PLC, click on Execute . The Execute window opens. Click on OK . The application is now being executed (in RUN mode) on the PLC simulator.

Execution of Application in Standard Mode

At a Glance

To work in standard mode you need to use a PLC and Analog I/O modules to assign outputs to different sensors and actuators.

The variables used in simulation mode must be modified. In standard mode, variables must be located to be associated to physical I/Os.

NOTE: For more information on addressing, see Unity Pro online help (click on ?, then Unity, then Unity Pro, then Languages reference, then Data description and Data instances

Input Wiring

The sensor is connected as follows.

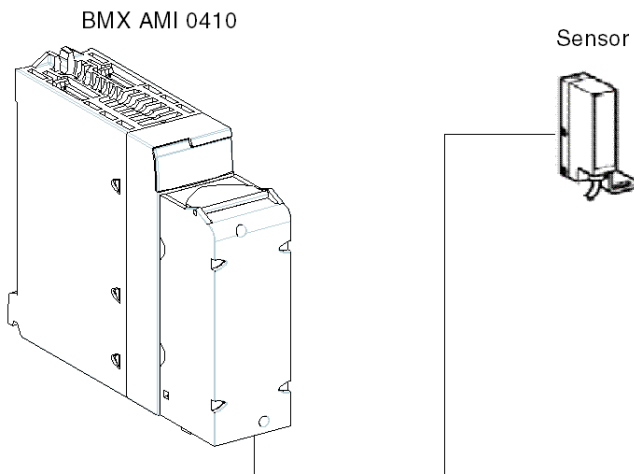

The assignment of the 20 pins terminal block is as follows.

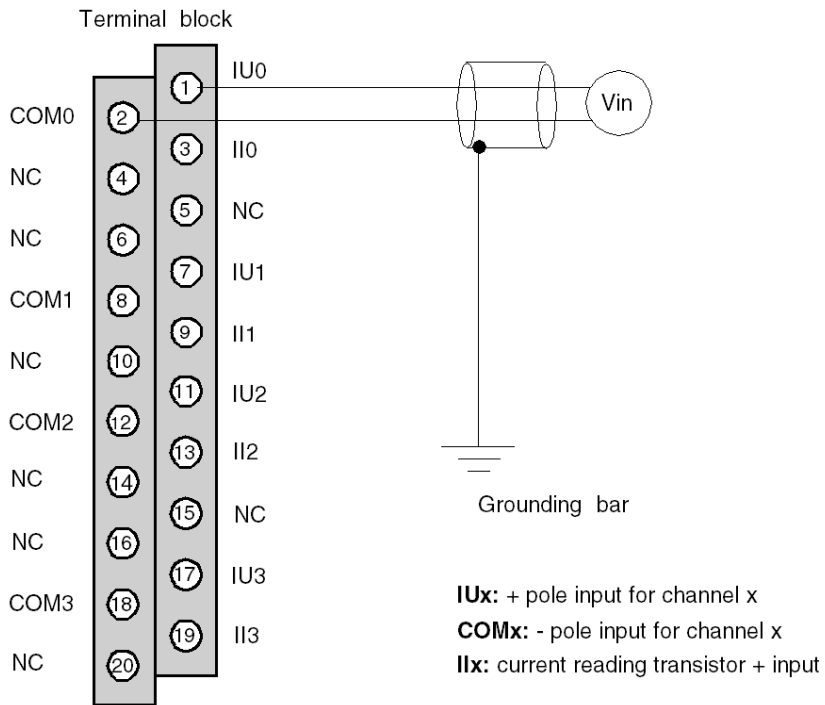

Output Wiring

The display is connected as follows.

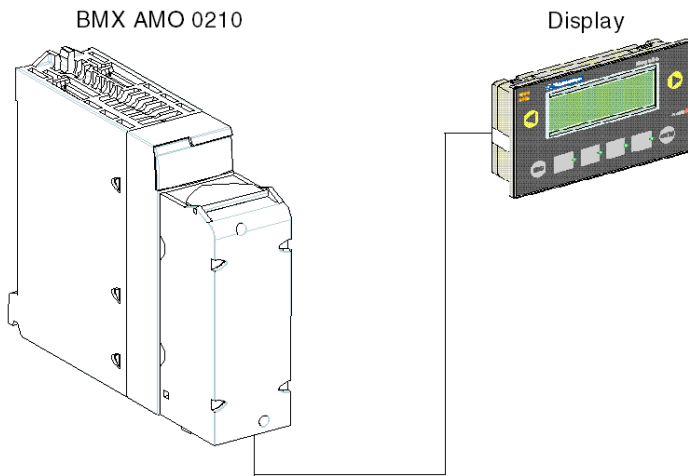

The assignment of the 20 pins terminal block is as follows.

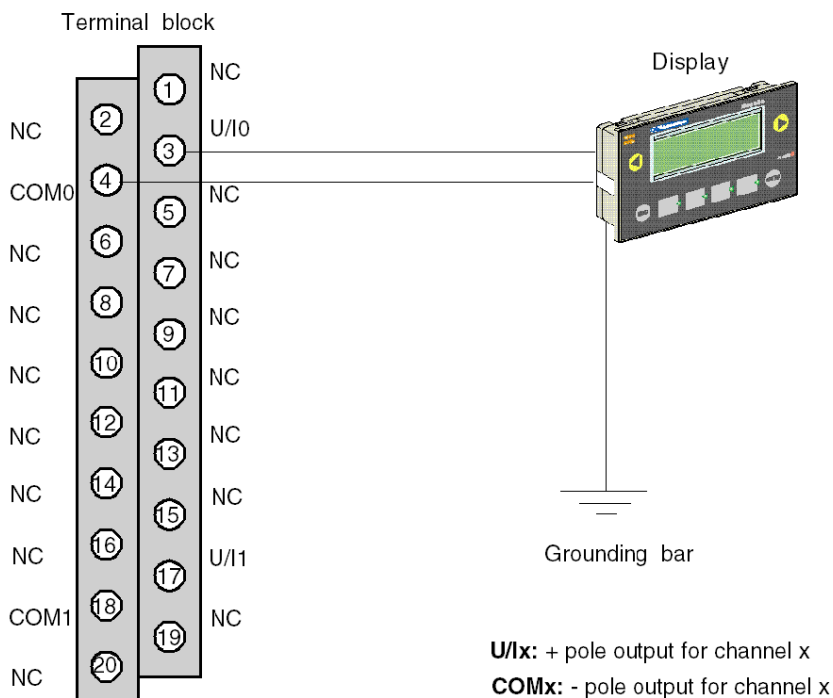

Application Hardware Configuration

The table below shows the procedure for configuring the application.

Step	Action
1	In the Project browser double-click on Configuration then on 0:Bus X and on 0:BMX XBP ... (where 0 is the rack number).
2	In the Bus X window, select a slot, for example 3 and double-click on it.
3	Insert an analog input module, for example BMX AMI 0410 The module appears on the PLC Bus ; Double-click on it..
4	In the 0.1 : BMX 0410 window, it's possible to configure the range and the scale of the used channels. For this application, configure the channel 0 to range 0..10V

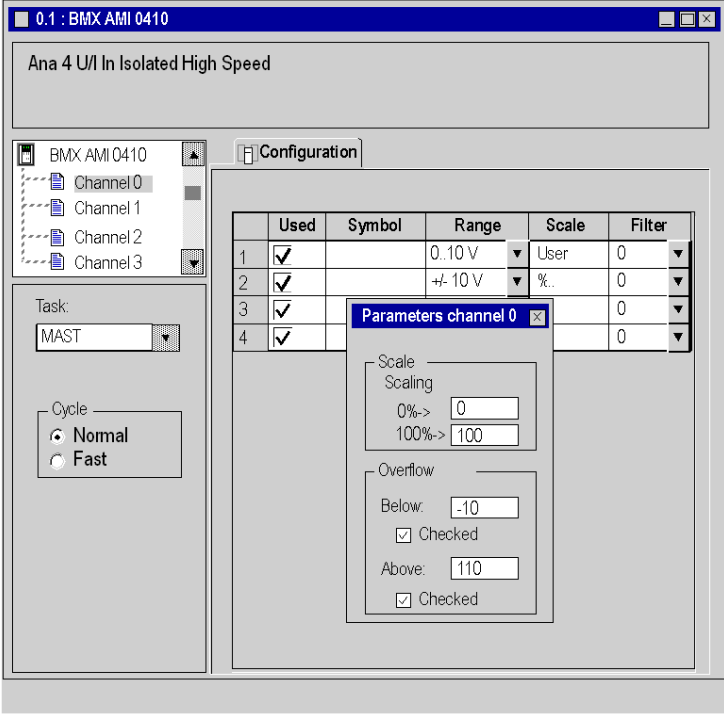
Step	Action																														
5	<p>Click in the channel 0 Scale zone. A windows opens. Define the different values as shown in the the figure below:</p>  <p>The screenshot shows the configuration window for '0.1 : BMX AMI 0410'. The main window title is 'Ana 4 U/I In Isolated High Speed'. On the left, there is a tree view with 'Channel 0' selected. Below it, the 'Task' is set to 'MAST' and the 'Cycle' is set to 'Normal'. The main area is titled 'Configuration' and contains a table with the following data:</p> <table border="1"> <thead> <tr> <th></th> <th>Used</th> <th>Symbol</th> <th>Range</th> <th>Scale</th> <th>Filter</th> </tr> </thead> <tbody> <tr> <td>1</td> <td><input checked="" type="checkbox"/></td> <td></td> <td>0..10 V</td> <td>User</td> <td>0</td> </tr> <tr> <td>2</td> <td><input checked="" type="checkbox"/></td> <td></td> <td>+/- 10 V</td> <td>%..</td> <td>0</td> </tr> <tr> <td>3</td> <td><input checked="" type="checkbox"/></td> <td></td> <td></td> <td></td> <td>0</td> </tr> <tr> <td>4</td> <td><input checked="" type="checkbox"/></td> <td></td> <td></td> <td></td> <td>0</td> </tr> </tbody> </table> <p>A dialog box titled 'Parameters channel 0' is open over the table. It has two sections: 'Scale' and 'Overflow'. The 'Scale' section has a 'Scaling' sub-section with two input fields: '0%->' with the value '0' and '100%->' with the value '100'. The 'Overflow' section has two sub-sections: 'Below' with the value '-10' and a checked 'Checked' checkbox, and 'Above' with the value '110' and a checked 'Checked' checkbox.</p>		Used	Symbol	Range	Scale	Filter	1	<input checked="" type="checkbox"/>		0..10 V	User	0	2	<input checked="" type="checkbox"/>		+/- 10 V	%..	0	3	<input checked="" type="checkbox"/>				0	4	<input checked="" type="checkbox"/>				0
	Used	Symbol	Range	Scale	Filter																										
1	<input checked="" type="checkbox"/>		0..10 V	User	0																										
2	<input checked="" type="checkbox"/>		+/- 10 V	%..	0																										
3	<input checked="" type="checkbox"/>				0																										
4	<input checked="" type="checkbox"/>				0																										

Assignment of Variables to Input Module

The table below shows the procedure for direct addressing of variables.

Step	Action
1	In the Project browser and in Variables & FB instances, double-click on Elementary variables.
2	In the Data editor window, select the box in the Name column and enter a name (Sensor_value for example). Select an INT type for this variable.
3	In the Address column, enter the analog value address associated with the variable. For this example, associate the Sensor_value variable with configured analog input channel by entering the address %IW0.1.0. Illustration: 

NOTE: Repeat the same procedure for declaring and configuring the analog output module BMX AMO 0210.

Input/Output Values Conversion

In this application, the level and the pump value are REAL type and the analog modules use integers. So Integer/Real conversions must be applied in a MAST task.

The screen below shows the I/O conversion section, written in DFB, using the Library Function Block.

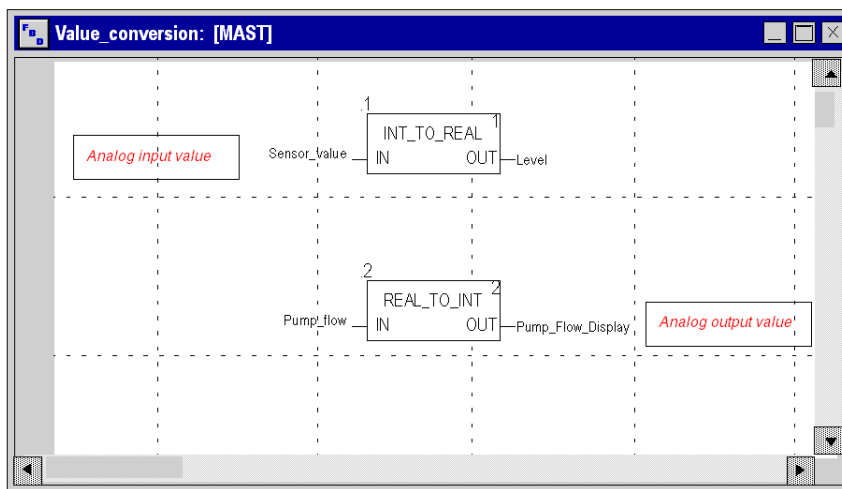

Application Execution

The table below shows the procedure for launching the application in standard mode.

Step	Action
1	In the PLC menu, click on Standard Mode,
2	In the Build menu, click on Rebuild All Project. Your project is generated and is ready to be transferred to the PLC. When you generate the project, you will see a results window. If there is an error in the program, Unity Pro indicates its location if you click on the highlighted sequence.
3	In the PLC menu, click on Connection. You are now connected to the PLC.
4	In the PLC menu, click on Transfer project to PLC. The Transfer project to PLC window opens. Click on Transfer. The application is transferred to the PLC.
5	In the PLC, click on Execute. The Execute window opens. Click on OK. The application is now being executed (in RUN mode) on the PLC.

Chapter 20

Actions and transitions

Subject of this chapter

This chapter contains the actions and the transitions used in the grafcet (See *Illustration of the Tank_management Section, page 322*)

What Is in This Chapter?

This chapter contains the following topics:

Topic	Page
Transitions	346
Actions	348

Transitions

At a glance

The next tasks are used in different transitions of the grafcet.

Filling_Start transition

The action associated to the **Filling_Start** transition is as follows:



With_Default transition

The action associated to the **With_Default** transition is as follows:

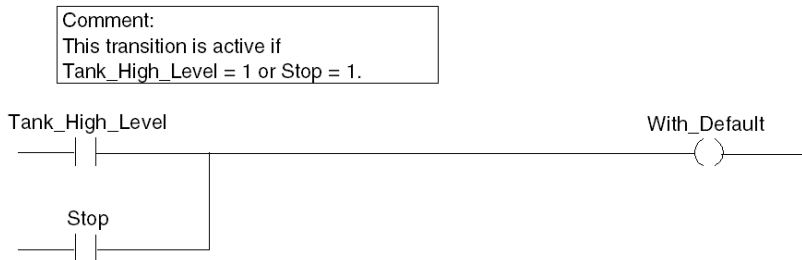

Reached_Level transition

The action associated to the **Reached_Level** transition is as follows:

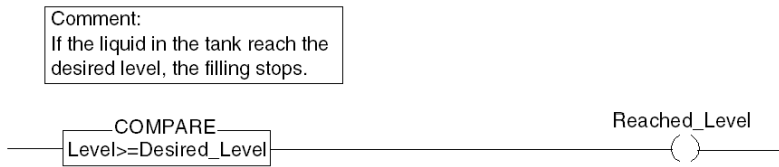

Filling_In_Progress transition

The action associated to the **Filling_In_Progress** transition is as follows:

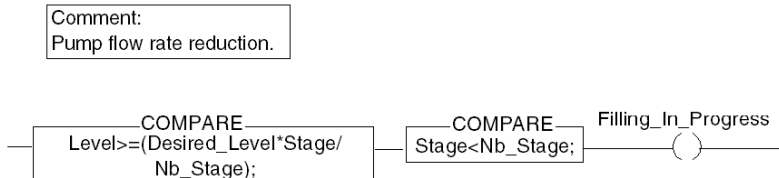

Empty_Tank transition

The action associated to the **Empty_Tank** transition is as follows:

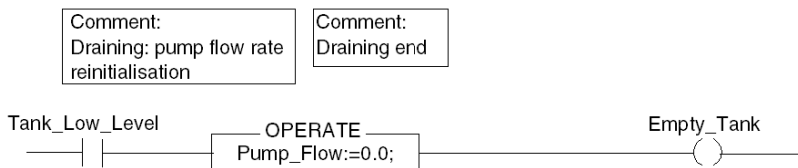

Actions

At a glance

The next tasks are used in different steps of the grafcet.

Initial step

The action associated to the **Initial** step is as follows:

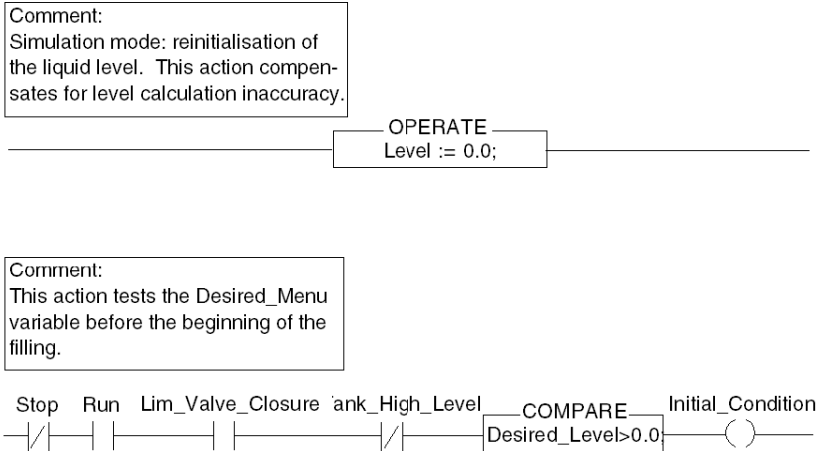

Init_Pump step

The action associated to the **Init_Pump** step is as follows:

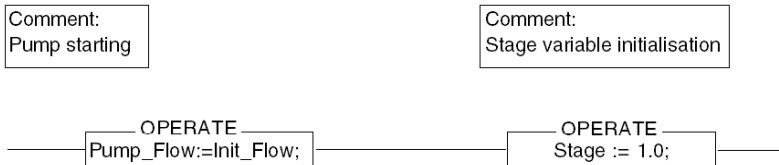

End_Alarm step

The action associated to the **End_Alarm** step is as follows:



Pump_Flow_Reduction step

The action associated to the **Pump_Flow_Reduction** step is as follows:

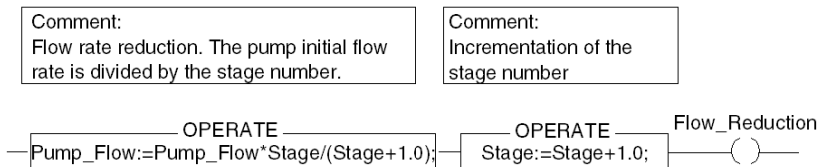

Appendices



Overview

These appendices contain information that should be useful for programming the application.

What Is in This Appendix?

The appendix contains the following chapters:

Chapter	Chapter Name	Page
A	Characteristics of the BMX ART 0414/0814 RTD and Thermocouple Ranges	353
B	Topological/State RAM Addressing of the Modules	365

Appendix A

Characteristics of the BMX ART 0414/0814 RTD and Thermocouple Ranges

Subject of this Section

This section presents the characteristics of the RTD and thermocouple ranges for the BMX ART 0414/0814 analog modules.

What Is in This Chapter?

This chapter contains the following topics:

Topic	Page
Characteristics of the RTD Ranges for the BMX ART 0414/0814 Modules	354
Characteristics of the BMX ART 0414/814 Thermocouple Ranges in Degrees Celsius	356
Characteristics of the BMX ART 0414/814 Thermocouple Ranges in Degrees Fahrenheit	360

Characteristics of the RTD Ranges for the BMX ART 0414/0814 Modules

At a Glance

The table below presents the maximum margin of error, at 25°C, of the Pt100, Pt1000, and Ni1000 RTD ranges.

Temperature		Pt100 RTD	Pt1000 RTD	Ni1000 RTD
Display resolution		0.1°C	0.1°C	0.1°C
Maximum error at 25°C (1)				
Operating point	-100°C	0.8°C	1.6°C	0.4°C
	0°C	0.8°C	1.6°C	0.5°C
	100°C	0.8°C	1.6°C	0.7°C
	200°C	1.0°C	2°C	0.6°C
	300°C	1.2°C	2.4°C	
	400°C	1.3°C	2.8°C	
	500°C	1.5°C	3.3°C	
	600°C	1.7°C	3.6°C	
	700°C	1.9°C	4.1°C	
800°C	2.1°C	4.5°C		
Input dynamic		-175..825°C -283..1,517°F	-175..825°C -283..1,517°F	-54..174°C -66..346°F
Legend:				
(1) Ambient temperature				

NOTE: The precision values are provided for a 3/4-wire connection and include the errors and drift of the 1.13 mA (Pt100) or 0.24 mA (Pt1000 or Ni1000) current source.

The effects of self-heating do not introduce any significant error to the measurement, whether the probe is in the air or under water.

The table below presents the maximum margin of error, between 0 and 60°C, of the Pt100, Pt1000, and Ni1000 RTD ranges.

Temperature		Pt100 RTD	Pt1000 RTD	Ni1000 RTD
Display resolution		0.1°C	0.1°C	0.1°C
Maximum error from 0 to 60°C				
Operating point	-100°C	1°C	2°C	0.8
	0°C	1°C	2°C	0.9°C
	100°C	1°C	2°C	1.1°C
	200°C	1.2°C	2.4°C	1.3°C
	300°C	1.5°C	3°C	
	400°C	1.8°C	3.6°C	
	500°C	2°C	4°C	
	600°C	2.3°C	4.6°C	
	700°C	2.5°C	5°C	
800°C	2.8°C	5.6°C		
Input dynamic		-175..825°C -283..1,517°F	-175..825°C -283..1,517°F	-54..174°C -66..346°F

NOTE: The precision values are provided for 4-wire connection and include the errors and drift of the 1.13 mA (Pt100) or 0.24 mA (Pt1000 or Ni1000) current source.

The effects of self-heating do not introduce any significant error to the measurement, whether the probe is in the air or under water.

An error at a given temperature T can be deduced by linear extrapolation of the errors defined at 25 and 60°C according to the formula:

$$\varepsilon_T = \varepsilon_{25} + |T - 25| \times |\varepsilon_{60} - \varepsilon_{25}| / 35$$

Reference standards:

- Pt100/Pt1000 RTD : NF C 42-330 June 1983 and IEC 751, 2nd edition 1986.
- Ni1000 RTD: DIN 43760 September 1987.

Characteristics of the BMX ART 0414/814 Thermocouple Ranges in Degrees Celsius

Introduction

The following tables show the measuring device errors for the various thermocouples B, E, J, K, N, R, S and T **in degrees Celsius**.

- The precision values given below are valid irrespective of the type of cold junction compensation: TELEFAST or Pt100 class A.
- The cold junction temperature considered in the precision calculation is 25°C.
- The resolution is given with a mid-range operating point.
- The precision values include:
 - electrical errors on the acquisition system for input channels and cold junction compensation, software errors and interchangeability errors on the cold junction compensation sensors.
 - thermocouple sensor errors are not taken into account.

Thermocouples B, E, J, and K

The table below shows the maximum error values for thermocouples B, E, J, and K at 25°C.

Temperature		Thermocouple B		Thermocouple E		Thermocouple J		Thermocouple K	
Maximum error at 25°C (1)		TFAST	Pt100	TFAST	Pt100	TFAST	Pt100	TFAST	Pt100
Operating point	-200°C			3.7°C	2.5°C			3.7°C	2.5°C
	-100°C			2.6°C	2.4°C	2.6°C	2.4°C	2.6°C	2.4°C
	0°C			2.5°C	2.3°C	2.5°C	2.3°C	2.5°C	2.3°C
	100°C			2.6°C	2.4°C	2.6°C	2.4°C	2.6°C	2.4°C
	200°C	3.5°C	3.4°C	2.6°C	2.4°C	2.6°C	2.4°C	2.6°C	2.5°C
	300°C	3.2°C	3.0°C	2.7°C	2.5°C	2.7°C	2.5°C	2.6°C	2.4°C
	400°C	3.0°C	2.8°C	2.7°C	2.5°C	2.7°C	2.5°C	2.7°C	2.5°C
	500°C	3.0°C	2.8°C	2.8°C	2.6°C	2.8°C	2.6°C	2.8°C	2.6°C
	600°C	3.0°C	2.8°C	2.8°C	2.6°C	2.8°C	2.6°C	2.8°C	2.6°C
	700°C	3.0°C	2.8°C	2.8°C	2.6°C	2.8°C	2.6°C	2.9°C	2.7°C
	800°C	3.0°C	2.8°C	2.9°C	2.7°C			2.9°C	2.7°C
	900°C	3.0°C	2.8°C	2.9°C	2.7°C			3.0°C	2.8°C
	1,000°C	3.0°C	2.8°C					3.0°C	2.8°C
	1,100°C	3.0°C	2.8°C					3.1°C	2.9°C
	1,200°C	3.0°C	2.8°C					3.2°C	3.0°C
	1,300°C	3.0°C	2.8°C					3.3°C	3.1°C
1,400°C	3.1°C	2.9°C							
1,500°C	3.1°C	2.9°C							
1,600°C	3.1°C	2.9°C							
1,700°C	3.2°C	3.0°C							
1,800°C	3.3°C	3.1°C							
Input dynamic		1710..17,790°C		-2,400..9,700°C		-7,770..7,370°C		-23,100..13.310°C	
Legend:									
(1) TFAST: Internal compensation by TELEFAST.									
PT100: External compensation by Pt100 3 wires.									

Reference standards: IEC 584-1, first edition, 1977 and IEC 584-2, second edition, 1989.

Thermocouples L, N, R, and S

The table below shows the maximum precision error values for thermocouples L, N, R, and S at 25°C.

Temperature		Thermocouple L		Thermocouple N		Thermocouple R		Thermocouple S	
Maximum error at 25°C (1)		TFAST	Pt100	TFAST	Pt100	TFAST	Pt100	TFAST	Pt100
Operating point	-200°C			3.7°C	2.5°C				
	-100°C			2.6°C	2.4°C				
	0°C	2.5°C	2.3°C	2.5°C	2.3°C	2.5°C	2.3°C	2.5°C	2.3°C
	100°C	2.6°C	2.4°C	2.6°C	2.4°C	2.6°C	2.4°C	2.6°C	2.4°C
	200°C	2.6°C	2.4°C	2.6°C	2.4°C	2.6°C	2.4°C	2.6°C	2.4°C
	300°C	2.6°C	2.4°C	2.6°C	2.4°C	2.6°C	2.4°C	2.6°C	2.4°C
	400°C	2.7°C	2.5°C	2.7°C	2.5°C	2.7°C	2.5°C	2.7°C	2.5°C
	500°C	2.7°C	2.5°C	2.7°C	2.5°C	2.7°C	2.5°C	2.7°C	2.5°C
	600°C	2.8°C	2.6°C	2.8°C	2.6°C	2.8°C	2.6°C	2.7°C	2.5°C
	700°C	2.8°C	2.6°C	2.8°C	2.6°C	2.8°C	2.6°C	2.8°C	2.6°C
	800°C	2.9°C	2.7°C	2.9°C	2.7°C	2.8°C	2.6°C	2.8°C	2.6°C
	900°C	2.9°C	2.7°C	2.9°C	2.7°C	2.9°C	2.7°C	2.9°C	2.7°C
	1,000°C			3.0°C	2.8°C	2.9°C	2.7°C	2.9°C	2.7°C
	1,100°C			3.0°C	2.8°C	2.9°C	2.7°C	3.0°C	2.8°C
	1,200°C			3.1°C	2.9°C	3.0°C	2.8°C	3.0°C	2.8°C
	1,300°C					3.0°C	2.8°C	3.1°C	2.9°C
	1,400°C					3.1°C	2.9°C	3.1°C	2.9°C
1,500°C					3.1°C	2.9°C	3.2°C	3.0°C	
1,600°C					3.2°C	3.0°C	3.2°C	3.0°C	
1,700°C					3.2°C	3.0°C	3.2°C	3.0°C	
Input dynamic		-1,740..8,740°C		-2,320..12,620°C		-90..16,240°C		-90..16,240°C	
Legend:									
(1) TFAST: Internal compensation by TELEFAST.									
PT100: External compensation by Pt100 3 wires.									

Reference standards:

- Thermocouple L: DIN 43710, December 1985 edition.
- Thermocouple N: IEC 584-1, second edition, 1989 and IEC 584-2, second edition, 1989.
- Thermocouple R: IEC 584-1, first edition, 1977 and IEC 584-2, second edition, 1989.
- Thermocouple S: IEC 584-1, first edition, 1977 and IEC 584-2, second edition, 1989.

Thermocouples T and U

The table below shows the maximum precision error values for thermocouples T and U at 25°C.

Temperature		Thermocouple T		Thermocouple U	
Maximum error at 25°C (1)		TFAST	Pt100	TFAST	Pt100
Operating point	-200°C	3.7°C	2.5°C		
	-100°C	3.6°C	2.4°C		
	0°C	3.5°C	2.3°C	2.5°C	2.3°C
	100°C	2.6°C	2.4°C	2.6°C	2.4°C
	200°C	2.6°C	2.4°C	2.6°C	2.4°C
	300°C	2.6°C	2.4°C	2.6°C	2.4°C
	400°C	2.7°C	2.5°C	2.7°C	2.5°C
	500°C			2.7°C	2.5°C
600°C			2.7°C	2.5°C	
Input dynamic		-2,540..3,840°C		-1,810..5,810°C	
Legend: (1) TFAST: Internal compensation by TELEFAST. PT100: External compensation by Pt100 3 wires.					

Reference standards:

- Thermocouple U: DIN 43710, December 1985 edition.
- Thermocouple T: IEC 584-1, first edition, 1977 and IEC 584-2, second edition, 1989.

Characteristics of the BMX ART 0414/814 Thermocouple Ranges in Degrees Fahrenheit

Introduction

The following tables show the errors of the measuring device for the various thermocouples B, E, J, K, N, R, S and T **in degrees Fahrenheit**.

- The precision values given below are valid for all of the type of cold junction compensation: TELEFAST or Pt100 class A.
- The cold junction temperature considered in the precision calculation is 77°F.
- The resolution is given with a mid-range operating point.
- The precision values include:
 - electrical errors on the acquisition system for input channels and cold junction compensation, software errors and interchangeability errors on the cold junction compensation sensors.
 - thermocouple sensor errors are not taken into account.

Thermocouples B, E, J and K

The table below shows the maximum precision error values for thermocouples B, E, J and K at 77°F:

Temperature		Thermocouple B		Thermocouple E		Thermocouple J		Thermocouple K	
Maximum error at 77°F (1)		TFAST	Pt100	TFAST	Pt100	TFAST	Pt100	TFAST	Pt100
Operating point	-300°F			6.7°F	4.5°F			6.7°F	4.5°F
	-100°F			4.7°F	4.3°F	4.7°F	4.3°F	4.7°F	4.3°F
	0°F			4.5°F	4.1°F	4.5°F	4.1°F	4.5°F	4.1°F
	200°F			4.7°F	4.3°F	4.7°F	4.3°F	4.7°F	4.3°F
	400°F	6.3°F	6.1°F	4.7°F	4.3°F	4.7°F	4.3°F	4.7°F	4.3°F
	600°F	5.8°F	5.4°F	4.9°F	4.5°F	4.9°F	4.5°F	4.9°F	4.5°F
	700°F	5.4°F	5.0°F	4.9°F	4.5°F	4.9°F	4.5°F	4.9°F	4.5°F
	900°F	5.4°F	5.0°F	5.0°F	4.7°F	5.0°F	4.7°F	5.0°F	4.7°F
	1,100°F	5.4°F	5.0°F	5.0°F	4.7°F	5.0°F	4.7°F	5.0°F	4.7°F
	1,300°F	5.4°F	5.0°F	5.0°F	4.7°F	5.0°F	4.7°F	5.2°F	4.9°F
	1,500°F	5.4°F	5.0°F	5.2°F	4.9°F			5.2°F	4.9°F
	1,700°F	5.4°F	5.0°F	5.2°F	4.9°F			5.4°F	5.0°F
	1,800°F	5.4°F	5.0°F					5.4°F	5.0°F
	2,000°F	5.4°F	5.0°F					5.4°F	5.0°F
	2,200°F	5.4°F	5.0°F					5.4°F	5.0°F
	2,400°F	5.4°F	5.0°F					5.4°F	5.0°F
	2,600°F	5.6°F	5.2°C						
2,700°F	5.6°F	5.2°C							
2,900°F	5.6°F	5.2°C							
3,100°F	5.8°F	5.4°F							
3,200°F	6.0°F	5.6°F							
Input dynamic		3,390..32,000°F		-3,990..17,770°F		-2,870..13,950°F		-3,830..24,270°F	
Legend:									
(1) TFAST: Internal compensation by TELEFAST.									
PT100: External compensation by Pt100 3 wires.									

Thermocouples L, N, R and S

The table below shows the maximum precision error values for thermocouples L, N, R and S at 77°F:

Temperature		Thermocouple L		Thermocouple N		Thermocouple R		Thermocouple S	
Maximum error at 77°F (1)		TFAST	Pt100	TFAST	Pt100	TFAST	Pt100	TFAST	Pt100
Operating point	-300°F			6.7°F	4.5°F				
	-100°F			4.7°F	4.3°F				
	0°F	4.5°F	4.1°F	4.5°F	4.1°F	4.5°F	4.1°F	4.5°F	4.1°F
	200°F	4.7°F	4.3°F	4.7°F	4.3°F	4.7°F	4.3°F	4.7°F	4.3°F
	400°F	4.7°F	4.3°F	4.7°F	4.3°F	4.7°F	4.3°F	4.7°F	4.3°F
	600°F	4.7°F	4.3°F	4.7°F	4.3°F	4.7°F	4.3°F	4.7°F	4.3°F
	700°F	4.9°F	4.5°F	4.9°F	4.5°F	4.9°F	4.5°F	4.9°F	4.5°F
	900°F	4.9°F	4.5°F	4.9°F	4.5°F	4.9°F	4.5°F	4.9°F	4.5°F
	1,100°F	5.0°F	4.7°F	5.0°F	4.7°F	5.0°F	4.7°F	4.9°F	4.5°F
	1,300°F	5.0°F	4.7°F	5.0°F	4.7°F	5.0°F	4.7°F	5.0°F	4.7°F
	1,500°F	5.2°F	4.9°F	5.2°F	4.9°F	5.2°F	4.9°F	5.2°F	4.9°F
	1,700°F	5.2°F	4.9°F	5.2°F	4.9°F	5.2°F	4.9°F	5.2°F	4.9°F
	1,800°F					5.2°F	4.9°F	5.2°F	4.9°F
	2,000°F					5.2°F	4.9°F	5.4°F	5.0°F
	2,200°F					5.4°F	5.0°F	5.4°F	5.0°F
	2,400°F					5.4°F	5.0°F	5.6°F	5.2°F
	2,600°F					5.6°F	5.2°F	5.6°F	5.2°F
2,700°F					5.6°F	5.2°F	5.8°F	5.4°F	
2,900°F					5.8°F	5.4°F	5.8°F	5.4°F	
3,000°F					5.8°F	5.4°F	5.8°F	5.4°F	
Input dynamic (2)		-2,800..16,040°F		-3,860..23,040°F		-160..29,950°F		-160..29,950°F	
Legend:									
(1) TFAST: Internal compensation by TELEFAST. PT100: External compensation by Pt100 3 wires.									
(2) Internal compensation: ambient temperature = 68°F. External compensation: ambient temperature = 86°F.									

Thermocouples T and U

The table below shows the maximum precision error values for thermocouples T and U at 77°F:

Temperature		Thermocouple T		Thermocouple U	
Maximum error at 77°F (1)		TFAST	Pt100	TFAST	Pt100
Operating point	-300°F	6.7°F	4.5°F		
	-100°F	6.5°F	4.3°F		
	0°F	6.3°F	4.1°F	4.5°F	4.1°F
	200°F	4.7°F	4.3°F	4.7°F	4.3°F
	400°F	4.7°F	4.3°F	4.7°F	4.3°F
	600°F	4.7°F	4.3°F	4.7°F	4.3°F
	700°F	4.9°F	4.5°F	4.9°F	4.5°F
	900°F			4.9°F	4.5°F
	1,100°F			4.9°F	4.5°F
Input dynamic (2)		-4,250..7,230°F		-2,930..10,770°F	
Legend:					
(1) TFAST: Internal compensation by TELEFAST. PT100: External compensation by Pt100 3 wires.					

Appendix B

Topological/State RAM Addressing of the Modules

Topological/State RAM Addressing of Modicon X80 Analog Modules

Analog Modules

With Unity Pro 6.1 or later and Modicon M340 firmware 2.4 or later, you can access the modules either via topological or State RAM addresses. Please also refer to *Memory Tab (see Unity Pro, Operating Modes)*.

The following table shows the Modicon X80 analog module objects that can be mapped to topological or State RAM addresses.

Module reference	Topological address	State RAM address
BME AHI 0812	%IW rack.slot.channel, channel [0,7]	-%IWStart address ... %IWStart address + 7
BME AHO 0412	%QW rack.slot.channel, channel [0,3]	-%MWStart address ... %MWStart address + 3
BMX AMI 0410	%IW rack.slot.channel, channel [0,3]	-%IWStart address ... %IWStart address + 3
BMX AMI 0800	%IW rack.slot.channel, channel [0,7]	-%IWStart address ... %IWStart address + 7
BMX AMI 0810	%IW rack.slot.channel, channel [0,7]	-%IWStart address ... %IWStart address + 7
BMX AMM 0600	%IW rack.slot.channel, channel [0,3] %QW rack.slot.channel, channel [4,5]	-%IWStart address ... %IWStart address + 3 and -%MWStart address ... %MWStart address + 1
BMX AMO 0210	%QW rack.slot.channel, channel [0,1]	-%MWStart address ... %MWStart address + 1
BMX AMO 0410	%QW rack.slot.channel, channel [0,3]	-%MWStart address ... %MWStart address + 3
BMX AMO 0802	%QW rack.slot.channel, channel [0,7]	-%MWStart address ... %MWStart address + 7
BMX ART 0414	%IW rack.slot.channel, channel [0,3]	-Value: -%IWStart address ... %IWStart address + 3 -Cold junction: -%IWStart address + 4
BMX ART 0814	%IW rack.slot.channel, channel [0,7]	-%IWStart address ... %IWStart address + 7 -Cold junction, ch 0-3: %IWStart address + 8 -Cold junction, ch 4-7: %IWStart address + 9

For additional information please refer to *Special Conversion for Compact I/O Modules (see Unity Pro, Concept Application Converter, User Manual)*.



!

%I

According to the IEC standard, %I indicates a discrete input-type language object.

%M

According to the IEC standard, %M indicates a memory bit-type language object.

%MW

According to the IEC standard, %MW indicates a memory word-type language object.

%Q

According to the IEC standard, %Q indicates a discrete output-type language object.

B

BIT

This is a binary unit for a quantity of information which can represent two distinct values (or statuses): 0 or 1.

BOOL

BOOL is the abbreviation of Boolean type. This is the elementary data item in computing. A BOOL type variable has a value of either: 0 (FALSE) or 1 (TRUE).

A BOOL type word extract bit, for example: %MW10 . 4.

BYTE

When 8 bits are put together, this is called a BYTE. A BYTE is either entered in binary, or in base 8.

The BYTE type is coded in an 8 bit format, which, in hexadecimal, ranges from 16#00 to 16#FF

D

DFB

DFB is the abbreviation of Derived Function Block.

DFB types are function blocks that can be programmed by the user ST, IL, LD or FBD.

By using DFB types in an application, it is possible to:

- simplify the design and input of the program,
- increase the legibility of the program,
- facilitate the debugging of the program,
- reduce the volume of the generated code.

DFB instance

A DFB type instance occurs when an instance is called from a language editor.

The instance possesses a name, input/output interfaces, the public and private variables are duplicated (one duplication per instance, the code is not duplicated).

A DFB type can have several instances.

E

EBOOL

EBOOL is the abbreviation of Extended Boolean type. It can be used to manage rising or falling edges, as well as forcing.

An **EBOOL** type variable takes up one byte of memory.

EFB

Is the abbreviation for Elementary Function Block.

This is a block which is used in a program, and which performs a predefined software function.

EFBs have internal statuses and parameters. Even where the inputs are identical, the output values may be different. For example, a counter has an output which indicates that the preselection value has been reached. This output is set to 1 when the current value is equal to the preselection value.

F

FBD

FBD is the abbreviation of Function Block Diagram.

FBD is a graphic programming language that operates as a logic diagram. In addition to the simple logic blocks (**AND**, **OR**, etc.), each function or function block of the program is represented using this graphic form. For each block, the inputs are located to the left and the outputs to the right. The outputs of the blocks can be linked to the inputs of other blocks to form complex expressions.

Function view

View making it possible to see the program part of the application through the functional modules created by the user (see Functional module definition).

I**IEC 61131-3**

International standard: Programmable Logic Controls
Part 3: Programming languages.

IL

IL is the abbreviation of Instruction List.

This language is a series of basic instructions.

This language is very close to the assembly language used to program processors.

Each instruction is composed of an instruction code and an operand.

Instantiate

To instantiate an object is to allocate a memory space whose size depends on the type of object to be instantiated. When an object is instantiated, it exists and can be manipulated by the program.

INT

INT is the abbreviation of single integer format (coded on 16 bits).

The lower and upper limits are as follows: -2 to the power of 31 to $(2$ to the power of 31) - 1.

Example:

-32768, 32767, 2#11111110001001001, 16#9FA4.

L**LD**

LD is the abbreviation of Ladder Diagram.

LD is a programming language, representing the instructions to be carried out in the form of graphic diagrams very close to a schematic electrical diagram (contacts, coils, etc.).

Located variable

A located variable is a variable for which it is possible to know its position in the PLC memory. For example, the variable `Water_pressure`, is associated with `%MW102`. `Water_pressure` is said to be located.

M**Master task**

Main program task.

It is obligatory and is used to carry out sequential processing of the PLC.

O

Operator screen

This is an editor that is integrated into Unity Pro, which is used to facilitate the operation of an automated process. The user regulates and monitors the operation of the installation, and, in the case of any unexpected event, can act quickly and simply.

R

REAL

Real type is a coded type in 32 bits.

The ranges of possible values are illustrated in gray in the following diagram:

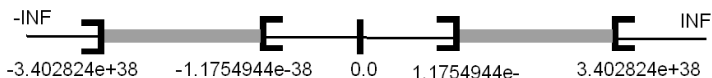

When a calculation result is:

- between $-1.175494e-38$ and $1.175494e-38$ it is considered as a DEN,
- less than $-3.402824e+38$, the symbol $-INF$ (for -infinite) is displayed,
- greater than $+3.402824e+38$, the symbol INF (for +infinite) is displayed,
- undefined (square root of a negative number), the symbol NAN is displayed.

S

Section

Program module belonging to a task which can be written in the language chosen by the programmer (FBD, LD, ST, IL, or SFC).

A task can be composed of several sections, the order of execution of the sections corresponding to the order in which they are created. This order is modifiable.

SFC

SFC is the abbreviation of Sequential Function Chart.

SFC enables the operation of a sequential automation device to be represented graphically and in a structured manner. This graphic description of the sequential behavior of an automation device, and the various situations which result from it, is provided using simple graphic symbols.

SFC objects

An SFC object is a data structure representing the status properties of an action or transition of a sequential chart.

ST

ST is the abbreviation of Structured Text language.

Structured Text language is an elaborated language close to computer programming languages. It enables you to structure series of instructions.

Structure

View in the project navigator with represents the project structure.

Subroutine

Program module belonging to a task (MAST, FAST) which can be written in the language chosen by the programmer (FBD, LD, ST, or IL).

A subroutine may only be called by a section or by another subroutine belonging to the task in which it is declared.

T**Task**

A group of sections and subroutines, executed cyclically or periodically for the MAST task, or periodically for the FAST task.

A task possesses a level of priority and is linked to inputs and outputs of the PLC. These I/O are refreshed in consequence.

TIME

The type `TIME` expresses a duration in milliseconds. Coded in 32 bits, this type makes it possible to obtain periods from 0 to $(2 \text{ to the power of } 32) - 1$ milliseconds.

U**Unlocated variable**

An unlocated variable is a variable for which it is impossible to know its position in the PLC memory. A variable which have no address assigned is said to be unlocated.

V**Variable**

Memory entity of the type `BOOL`, `WORD`, `DWORD`, etc., whose contents can be modified by the program during execution.

W**WORD**

The **WORD** type is coded in 16 bit format and is used to carry out processing on bit strings.

This table shows the lower/upper limits of the bases which can be used:

Base	Lower limit	Upper limit
Hexadecimal	16#0	16#FFFF
Octal	8#0	8#177777
Binary	2#0	2#1111111111111111

Representation examples

Data content	Representation in one of the bases
0000000011010011	16#D3
1010101010101010	8#125252
0000000011010011	2#11010011



A

- ABE-7CPA02/03/31E, *96*
 - Connecting to the BMX AMI 0800, *96*
- ABE-7CPA02/31/31E, *119*
 - Connecting to the BMX AMI 0810, *119*
- ABE-7CPA410, *76*
 - Connecting to the BMX AMI 0410, *78*
- ABE-7CPA412, *146*
- ABE7-CPA410, *53*
- ABE7-CPA412, *53*
- actuator alignment
 - BMXAMM0600, *209*
 - BMXAMO0210, *158*
 - BMXAMO0410, *173*
 - BMXAMO0802, *187*

B

- BMX FCA xx0
 - Connecting to the BMX AMI 0410, *78*
- BMXAMI0410, *59*
- BMXAMI0800, *79*
- BMXAMI0810, *103*
- BMXAMM0600, *193*
- BMXAMO0210, *149*
- BMXAMO0410, *165*
- BMXAMO0802, *179*
- BMXART0414, *125*
- BMXART0814, *125*
- BMXFCWxx1S, *47*
- BMXFTWxx1S, *36, 45*
- BMXXSP0400, *50*
- BMXXSP0600, *50*
- BMXXSP0800, *50*
- BMXXSP1200, *50*

C

- certifications, *61*
- channel data structure for all modules
 - T_GEN_MOD, *253*
- channel data structure for analog inputs
 - T_ANA_IN_GEN, *251*
- channel data structure for analog modules
 - T_ANA_IN_BMX, *242*
 - T_ANA_IN_T_BMX, *245*
 - T_ANA_OUT_BMX, *248*
 - T_ANA_OUT_GEN, *252*
- cold junction compensation, *238*
 - BMXART0814, *145*
- configuring analog inputs, *219*
- configuring analog outputs, *219*
- connection cables, *38, 46*
- connector modules, *47*

D

- debugging analog inputs, *265*
- debugging analog outputs, *265*
- diagnostics for analog outputs, *273*
- diagnostics for analog inputs, *273*

F

- fallback mode for analog outputs, *157, 172, 186, 208*
- filtering analog input
 - BMXAMI0410, *69*
 - BMXAMI0800, *89*
 - BMXAMI0810, *112*
 - BMXAMM0600, *205*
- filtering analog outputs
 - BMXART0814, *136*
- forcing
 - X80 analog I/O, *262*

G

grounding accessories, *50*
 BMXXSP0400, *50*
 BMXXSP0600, *50*
 BMXXSP0800, *50*
 BMXXSP1200, *50*
 STBXSP3010, *50*
 STBXSP3020, *50*
guidance wheel, *24*

I

IODDTs, *241*

K

keying wheel, *24*

L

language objects, *241*

M

measurement values, *287*
MOD_FLT, *261*
Mounting the terminal block, *28*

O

overflow monitoring
 BMXAMI0410, *66*
 BMXAMI0800, *86*
 BMXAMI0810, *110*
 BMXAMM0600, *203, 207*
 BMXAMO0210, *156*
 BMXAMO0410, *171*
 BMXAMO0802, *185*

P

programming , *287*

Q

quick start, *301*
 actions and transitions, *345*

S

scan cycles
 analog inputs, *230*
sensor alignment
 BMXAMI0410, *70*
 BMXAMI0800, *90*
 BMXAMI0810, *113*
 BMXAMM0600, *206*
 BMXRT0814, *137*
software implementation
 operating modules, *279*
standards, *61*
state RAM/topological addressing
 X80 analog I/O, *365*
STBXMP7800, *24*
STBXSP3010, *50*
STBXSP3020, *50*

T

T_ANA_IN_BMX, *242*
T_ANA_IN_GEN, *251*
T_ANA_IN_T_BMX, *245*
T_ANA_OUT_BMX, *248*
T_ANA_OUT_GEN, *252*
T_GEN_MOD, *253*
T_M_ANA_STD_CH_IN_PRM, *258*
T_M_ANA_STD_CH_IN_STS, *258*
T_M_ANA_STD_CH_OUT_PRM, *258*
T_M_ANA_STD_CH_OUT_STS, *258*
T_M_ANA_STD_CH_STS, *258*
T_M_ANA_TEMP_CH_STS, *258*
T_U_ANA_STD_IN_4, *254*
T_U_ANA_STD_IN_4_OUT_2, *254*
T_U_ANA_STD_IN_8, *254*
T_U_ANA_STD_OUT_2, *254*
T_U_ANA_STD_OUT_4, *254*
T_U_ANA_STD_OUT_8, *254*
T_U_ANA_TEMP_IN_4, *254*
T_U_ANA_TEMP_IN_8, *254*

TELEFAST

- Connecting to the BMXAMI0410, *76*
- Connecting to the BMXAMI0800, *96*
- Connecting to the BMXAMI0810, *119*

Telefast 2, *53***terminal blocks**

- BMWFTB2020, *31*
- BMXFTB2000, *31*
- BMXFTB2010, *31*
- BMXFTB2800, *39*
- BMXFTB2820, *39*
- coding, *24*
- connecting, *35, 44*
- installing, *23*

thermocouple ranges

- BMXART0814, *356*

timing

- BMXAMI0410, *66*
- BMXAMI0800, *86*
- BMXAMI0810, *109*
- BMXAMM0600, *202*

TRD ranges

- BMXART0814, *354*

U**underflow monitoring**

- BMXAMI0410, *66*
- BMXAMI0800, *86*
- BMXAMI0810, *110*
- BMXAMM0600, *203*

W**wiring accessories, *53*****wiring precautions**

- BMXAMI0410, *71*
- BMXAMI0800, *91*
- BMXAMI0810, *114*
- BMXAMM0600, *210*
- BMXAMO0210, *159*
- BMXAMO0410, *174*
- BMXAMO0802, *188*
- BMXART0814, *139*

X**X80 analog I/O**

- state RAM/topological addressing, *365*

