



# SOLUTION AIR HANDLING UNITS

RENEWAL PARTS

Supersedes: 102.20-RP1 (504)

Form 102.20-RP1 (1104)



LDO9624



LDO9688

# IMPORTANT!

## READ BEFORE PROCEEDING!

### GENERAL SAFETY GUIDELINES

This equipment is a relatively complicated apparatus. During installation, operation, maintenance or service, individuals may be exposed to certain components or conditions including, but not limited to: refrigerants, oils, materials under pressure, rotating components, and both high and low voltage. Each of these items has the potential, if misused or handled improperly, to cause bodily injury or death. It is the obligation and responsibility of operating/service personnel to identify and recognize these inherent hazards, protect themselves, and proceed safely in completing their tasks. Failure to comply with any of these requirements could result in serious damage to the equipment and the property in

which it is situated, as well as severe personal injury or death to themselves and people at the site.

This document is intended for use by owner-authorized operating/service personnel. It is expected that this individual possesses independent training that will enable them to perform their assigned tasks properly and safely. It is essential that, prior to performing any task on this equipment, this individual shall have read and understood this document and any referenced materials. This individual shall also be familiar with and comply with all applicable governmental standards and regulations pertaining to the task in question.

### SAFETY SYMBOLS

The following symbols are used in this document to alert the reader to areas of potential hazard:



***DANGER*** indicates an imminently hazardous situation which, if not avoided, will result in death or serious injury.



***CAUTION*** identifies a hazard which could lead to damage to the machine, damage to other equipment and/or environmental pollution. Usually an instruction will be given, together with a brief explanation.



***WARNING*** indicates a potentially hazardous situation which, if not avoided, could result in death or serious injury.

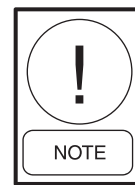

***NOTE*** is used to highlight additional information which may be helpful to you.



***External wiring, unless specified as an optional connection in the manufacturer's product line, is NOT to be connected inside the micro panel cabinet. Devices such as relays, switches, transducers and controls may NOT be installed inside the micro panel. NO external wiring is allowed to be run through the micro panel. All wiring must be in accordance with YORK's published specifications and must be performed ONLY by qualified YORK personnel. YORK will not be responsible for damages/problems resulting from improper connections to the controls or application of improper control signals. Failure to follow this will void the manufacturer's warranty and cause serious damage to property or injury to persons.***

## TABLE OF CONTENTS

FASTENERS FOR SOLUTION UNITS.....	9 - 10
GASKET/CAULK/ADHESIVE FOR SOLUTION UNITS.....	11 - 12
DOOR LATCHING PARTS .....	13 - 14
DOOR GASKETS .....	14
THRUST RESTRAINT KIT SELECTION.....	16
THRUST RESTRAINT KITS .....	17 - 18
FAN MOTORS.....	22 - 26
MOTOR WIRING PARTS.....	27
ADJUSTABLE MOTOR BASES.....	28 - 30
FANS AND MOTORS, SECURING.....	32
ISOLATORS.....	33 - 34
SHELL COMPONENTS.....	35
SPLICE & SPLIT BASERAIL KITS .....	36 - 37
WIREWAY ACCESS PLATES.....	41
FILTERS.....	42 - 46
OA HOOD MOISTURE ELIMINATOR FILTERS (BY DAMPER SIZE).....	47 - 55
VISUAL CONTROL FILTER CLAMPS FOR HEPA FILTERS .....	58
LIGHTING PARTS .....	59
ELECTRICAL REPLACEMENT PARTS .....	60
WIRING-HARNESSES LIGHT ASSEMBLY - PANEL TO WIRE TRACK .....	61
WIRING-HARNESSES LIGHT ASSEMBLY - WIRE TRACK .....	62
WIRING-HARNESSES LIGHT ASSEMBLY - TIER TO TIER.....	63
SWITCH/RECEPTACLE .....	63
TRANSFORMER PANEL.....	64
FILTER GAGE KITS .....	65
PART NUMBER INDEX .....	67 - 89

## ALPHABETIZED TABLE OF CONTENTS

ADJUSTABLE MOTOR BASES .....	28 - 30
DOOR GASKETS .....	14
DOOR LATCHING PARTS .....	13 - 14
ELECTRICAL REPLACEMENT PARTS .....	60
FANS AND MOTORS, SECURING.....	32
FAN MOTORS.....	22 - 26
FASTENERS FOR SOLUTION UNITS.....	9 - 10
FILTERS.....	42 - 46
FILTER GAGE KITS .....	65
GASKET/CAULK/ADHESIVE FOR SOLUTION UNITS.....	11 - 12
ISOLATORS.....	33 - 34
LIGHTING PARTS .....	59
MOTOR WIRING PARTS.....	27
OA HOOD MOISTURE ELIMINATOR FILTERS (BY DAMPER SIZE).....	47 - 55
PART NUMBER INDEX .....	67 - 89
SHELL COMPONENTS .....	35
SPLICE & SPLIT BASERAIL KITS .....	36 - 37
SWITCH/RECEPTACLE .....	63
THRUST RESTRAINT KITS .....	17 - 18
THRUST RESTRAINT KIT SELECTION.....	16
TRANSFORMER PANEL.....	64
VISUAL CONTROL FILTER CLAMPS FOR HEPA FILTERS .....	58
WIREWAY ACCESS PLATES.....	41
WIRING-HARNESSES LIGHT ASSEMBLY - PANEL TO WIRE TRACK .....	61
WIRING-HARNESSES LIGHT ASSEMBLY - TIER TO TIER.....	63
WIRING-HARNESSES LIGHT ASSEMBLY - WIRE TRACK.....	62



**GENERAL**

This renewal parts list provides replacement part numbers that can be ordered from the York Parts Warehouse (Tel. 800-932-1701). Refer to the data tag on your equipment for the unit size, fan size and accessories that comprise your unit. Compare this data tag information with the nomenclature below and on the next page to completely identify all components in your system. Furnish this model number and the York order number on which the unit was originally furnished when ordering replacement parts.

TABLE 1 – SEGMENT IDENTIFICATION (SEE FIG.1-2)

Fan Segments	Filter Segments
<ul style="list-style-type: none"> <li>• FS – Supply               <ul style="list-style-type: none"> <li>o Forward Curved</li> <li>o Airfoil</li> <li>o Industrial Airfoil</li> <li>o SWSI Plenum (Belt and Direct Drive)</li> </ul> </li> </ul>	<ul style="list-style-type: none"> <li>• FF – Flat Filter (2” or 4”)</li> <li>• AF – Angle Filter (2”)</li> <li>• RF – High Efficiency Filter               <ul style="list-style-type: none"> <li>o Rigid Filter (12”)</li> <li>o Bag Filter (21”)</li> <li>o Mini Pleat Filter (4”)</li> </ul> </li> <li>• HF – HEPA Filter</li> <li>• CF – Carbon Filter</li> </ul>
<ul style="list-style-type: none"> <li>• FR – Return Fan               <ul style="list-style-type: none"> <li>o Forward Curved</li> <li>o Airfoil</li> <li>o Industrial Airfoil</li> <li>o SWSI Plenum (Belt &amp; Direct Drive)</li> </ul> </li> </ul>	<b>Inlet Segments</b> <ul style="list-style-type: none"> <li>• MB – Mixing Box</li> <li>• FM – Filter / Mixing Box</li> <li>• EF – Filter / Economizer</li> <li>• EE – Economizer</li> <li>• IP – Inlet Plenum</li> </ul>
<ul style="list-style-type: none"> <li>• FE – Exhaust Fan               <ul style="list-style-type: none"> <li>o Forward Curved</li> <li>o Airfoil</li> <li>o Industrial Airfoil</li> </ul> </li> </ul>	<b>Accessory Segments</b> <ul style="list-style-type: none"> <li>• VP – Vertical Plenum</li> <li>• DP – Discharge Plenum</li> <li>• TN – Turning Plenum</li> <li>• DI – Diffuser</li> <li>• XA – Access Segment</li> <li>• IG – Indirect-Fired Gas Furnace</li> <li>• ER – Energy Recovery Wheel</li> <li>• AB – Air Blender</li> <li>• FD – Face Damper</li> <li>• EB – External Face &amp; Bypass</li> <li>• HM – Humidifier</li> <li>• AT – Sound Attenuator</li> </ul>
<b>Coil Segments</b> <ul style="list-style-type: none"> <li>o CC – Cooling Coil</li> <li>o HC – Heating Only Coil</li> <li>o VC – Vertical Coil</li> <li>o IC – Heat Only, Integral Face &amp; Bypass Coil</li> <li>o IB – Internal Face &amp; Bypass Coil</li> </ul>	

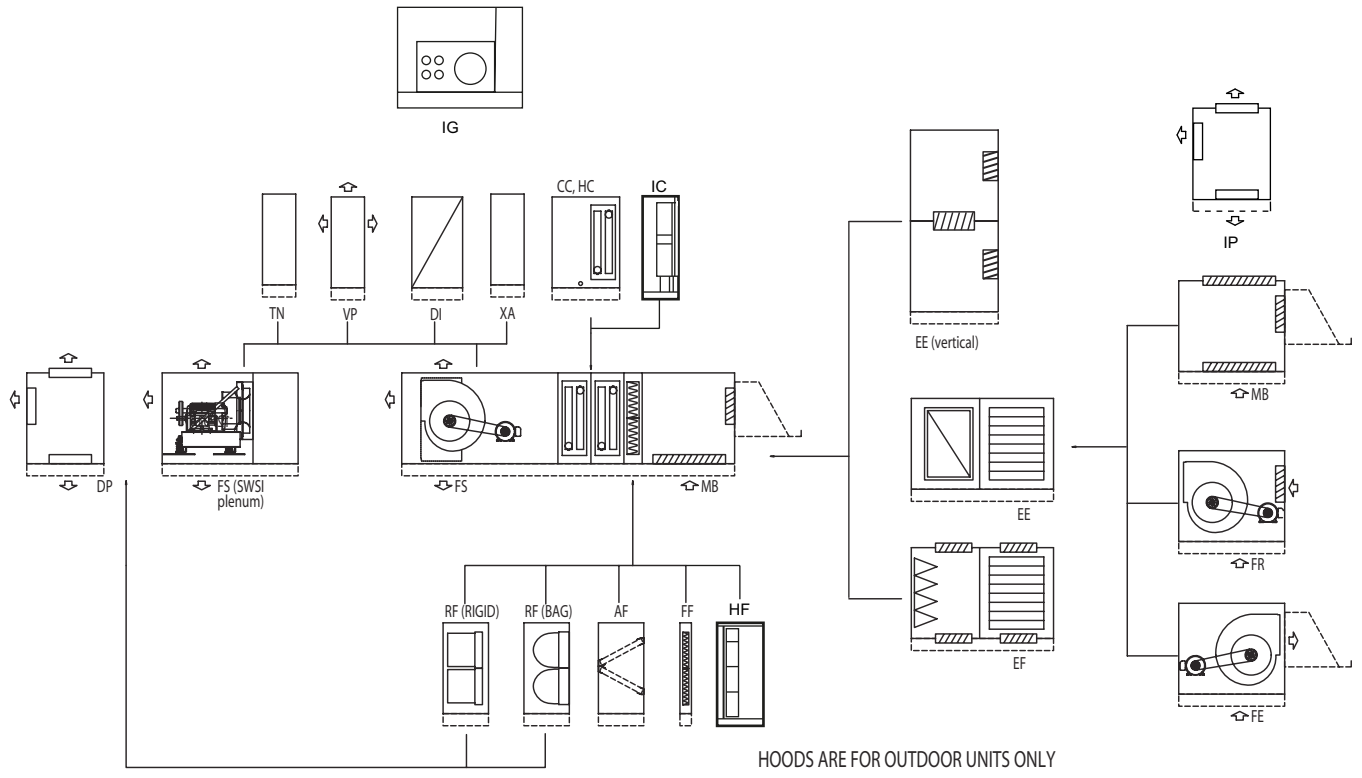

...  
LD08003B

FIG. 1 - (SEE TABLE 1) SEGMENT AVAILABILITY

TABLE 2 – UNIT NOMENCLATURE

**Solution Unit Model Number.**

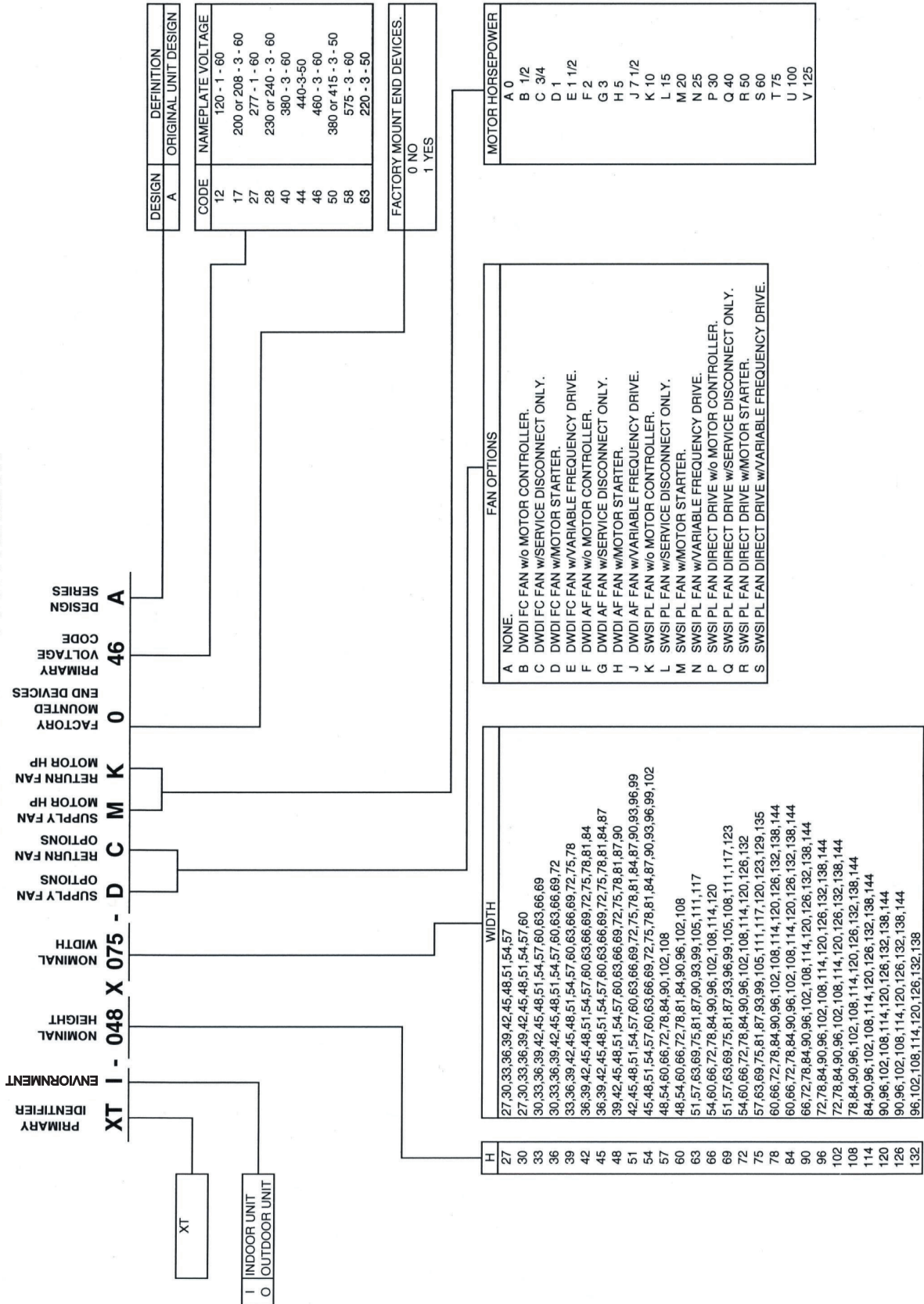

DESIGN	DEFINITION
A	ORIGINAL UNIT DESIGN

CODE	NAMEPLATE VOLTAGE
12	120 - 1 - 60
17	200 or 208 - 3 - 60
27	277 - 1 - 60
28	230 or 240 - 3 - 60
40	380 - 3 - 60
44	440-3-50
46	460 - 3 - 60
50	380 or 415 - 3 - 50
58	575 - 3 - 60
63	220 - 3 - 50

FACTORY MOUNT END DEVICES.
0 NO
1 YES

MOTOR HORSEPOWER
A 0
B 1/2
C 3/4
D 1
E 1 1/2
F 2
G 3
H 5
J 7 1/2
K 10
L 15
M 20
N 25
P 30
Q 40
R 50
S 60
T 75
U 100
V 125

FAN OPTIONS
A NONE.
B DWDI FC FAN w/o MOTOR CONTROLLER.
C DWDI FC FAN w/SERVICE DISCONNECT ONLY.
D DWDI FC FAN w/MOTOR STARTER.
E DWDI FC FAN w/VARIABLE FREQUENCY DRIVE.
F DWDI AF FAN w/o MOTOR CONTROLLER.
G DWDI AF FAN w/SERVICE DISCONNECT ONLY.
H DWDI AF FAN w/MOTOR STARTER.
J DWDI AF FAN w/VARIABLE FREQUENCY DRIVE.
K SWSI PL FAN w/o MOTOR CONTROLLER.
L SWSI PL FAN w/SERVICE DISCONNECT ONLY.
M SWSI PL FAN w/MOTOR STARTER.
N SWSI PL FAN w/VARIABLE FREQUENCY DRIVE.
P SWSI PL FAN DIRECT DRIVE w/o MOTOR CONTROLLER.
Q SWSI PL FAN DIRECT DRIVE w/SERVICE DISCONNECT ONLY.
R SWSI PL FAN DIRECT DRIVE w/MOTOR STARTER.
S SWSI PL FAN DIRECT DRIVE w/VARIABLE FREQUENCY DRIVE.

H	WIDTH
27	27,30,33,36,39,42,45,48,51,54,57
30	27,30,33,36,39,42,45,48,51,54,57,60,63,66,69
33	30,33,36,39,42,45,48,51,54,57,60,63,66,69
36	30,33,36,39,42,45,48,51,54,57,60,63,66,69,72
39	33,36,39,42,45,48,51,54,57,60,63,66,69,72,75,78
42	36,39,42,45,48,51,54,57,60,63,66,69,72,75,78,81,84
45	36,39,42,45,48,51,54,57,60,63,66,69,72,75,78,81,84,87
48	39,42,45,48,51,54,57,60,63,66,69,72,75,78,81,87,90
51	42,45,48,51,54,57,60,63,66,69,72,75,78,81,84,87,90,93,96,99
54	42,45,48,51,54,57,60,63,66,69,72,75,78,81,84,87,90,93,96,99,102
57	48,54,60,66,72,78,84,90,102,108
60	48,54,60,66,72,78,81,84,90,96,102,108
63	51,57,63,69,75,81,87,90,93,99,105,111,117
66	54,60,66,72,78,84,90,96,102,108,114,120
69	51,57,63,69,75,81,87,93,99,105,108,111,117,123
72	54,60,66,72,78,84,90,96,102,108,114,120,126,132
75	57,63,69,75,81,87,93,99,105,111,117,120,123,129,135
78	60,66,72,78,84,90,96,102,108,114,120,126,132,138,144
84	60,66,72,78,84,90,96,102,108,114,120,126,132,138,144
90	66,72,78,84,90,96,102,108,114,120,126,132,138,144
96	72,78,84,90,96,102,108,114,120,126,132,138,144
102	72,78,84,90,96,102,108,114,120,126,132,138,144
108	78,84,90,96,102,108,114,120,126,132,138,144
114	84,90,96,102,108,114,120,126,132,138,144
120	90,96,102,108,114,120,126,132,138,144
126	90,96,102,108,114,120,126,132,138,144
132	96,102,108,114,120,126,132,138

Notes: 1. The height and width numbers only correspond to each other in the same row.



FASTENERS FOR SOLUTION UNITS		
PART NUMBER	DESCRIPTION	WHERE USED
021-00331-000	BOLT, LAG HEX 3/8 X2-1/2 ZINC PLATED	Tie down plate to shipping skid/wood
021-01154-000	WASH, LK TH INT 5/16 HVY,ZINC PLTD., STD. C-76	RF Filter Tracks
021-01155-000	WASH, LK TH INT 3/8 STD C-76	Fan Skid, Lifting Lugs
021-01163-000	WASH, LK TH INT 1/2 HVY STL ZINC PLTD., STD. C-76	Fan Skid, Lifting Lugs
021-01168-000	WASH LK TH INT 5/8 STL ZINC PLTD., STD. C-76	Blower Mounting
021-01248-000	WASHER PLAIN 5/16 ID X 3/4 OD X 0.065 NOM THK : STEEL	Blower Mounting
021-01267-000	WASH FLT 7/16 ID X 1 OD X 0.083 THK STL ZINC PLTD.	Snubber
021-01288-000	WASH FLT 11/16 ID X 1-3/4 OD 0.134 THK STL ZINC PLTD., STD. C-48	Blower Mounting
021-01481-000	SCR, CAP HEX 3/8 - 16 UNC - 2A X 1.0, ZINC PLATED	Fan Skid
021-01499-000	SCREW, CAP HEX 3/8 - 16 UNC - 2A X 1.5, ZINC PLATED	Blower Mounting
021-02523-000	NUT, HEX 5/16 - 18 UNC - 2B STL ZINC PLTD	RF Filter Tracks
021- 02782- 000	Scr Hex Cap 5/16-18 X 1-1/4, 1-1/4 Lg Stl Zinc Pltd	Blower Mounting
021-02794-000	SCR HEX 5/8-11UNC-2A X 2.00" SAE J429	Blower Mounting
021-02860-000	NUT, HEX 1/2-13 HVY 7/8 STL ZINC PLTD., STD. C-85	Fan Skid
021-02862-000	NUT HEX 5/8-11 HVY STL ZINC PLTD., STD. C-85	Blower Mounting
021-03749-000	SCR MACH RD PH 1/4-20UNC-2A X 1-1/4 LG STL ZINC PLTD.	Blower Mounting
021-05146-000	WASH, FLT 9/16 ID X 1-3/8 OD .109 THK STL ZINC PLATED	Fan Skid
021-08388-000	SCR, HEX 1/2-13UNC-2A X 1" STL ZINC PLTD, SAE J429	Fan Skid
021-08394-000	SCR, HEX CAP 5/16-18 X 3/4 LG STL ZINC PLTD	RF Filter Tracks
021-08395-000	SCR, CAP HEX 3/8 - 16 UNC - 2A X 0.75, STL ZINC PLTD	Secures Block To Motor Base
021-09983-000	WASH, FLT 3/8 ID X 7/8 OD 0.083 THK STL ZINC PLATED,ANSI B27.2, STD C-48	RF Filter Tracks
021-10186-000	LOCK WASHER SPG HELICAL 1/4, STEEL	Blower Mounting
021-11645-000	NUT, RET 3/8-16.162/.210 .162 - .210 PANEL RANGE, STD. C-77	Fan Skid
021-12656-000	NUT HEX 3/4-10 HVY STL ZINC CTD ASA B18	Blower Mounting
021-12917-000	SCR, TAP TY B HEX 5/16 X 3/4 5/16 DIA X 3/4 LG STL CD PL	Fan Skid, Coil supports, Coil blockoff to coil casing
021-13291-000	NUT RET 1/4-20 0125-0.156 PANEL RANGE, STD. C-77	Economizer hatch
021-13734-000	SCR, TAP TY F PAN 1/4 X 1/2 LG STL ZINC PLTD	Hood & Hood Gutter
021-13830-000	SCR HEX CAP 3/4-10 X 2-1/2, STL ZINC PLTD	Blower Mounting
021-13863-000	SCR, TAP SELF DRILL 10-24 X 1/2 HD #10-24 X 1/2 LG STYLE 3 SHAKE-PROOF # 621-100880-00-0251T,STL,ZINC PLTD	Control Brackets
021-13911-000	SCR, TAP TYPE B HEX 3/8 X 3/4 STL ZINC PLTD.	Fan Skid, Coil stacking splice
021-15802-000	WASH FLT 13/16 ID X 1-3/4 OD X 0.134 THK STL ZINC	Blower Mounting
021-16151-000	LOCK WASHER SPG HELICAL 1/4, STEEL	Blower Mounting
021-17212-000	SCREW,HEX HD CAP,1/4-20X1-1/2", FULL THREAD, ZINC PLATED	Blower Mounting
021-17711-000	RIVET, POP, 1/8"x1/4" GRIP	Panel outer to liner
021-17717-000	NUT, HEX LK 3/8-16, ZINC PLATED	Fan Skid
021-17718-000	NUT HEX 1/4 - 20 UNC - 2B	Blower Mounting
021-17722-000	SCR, TAP TY A PH 14-10 1/4 X3/4 PAN HEAD, PHILLIPS (#1), TYPE A, ZINC PLATED	Primary screw for inside sheet metal, panels outside unit , damper mounting, Shipping tie down to raceway
021-17728-000	SCR HEX 1/2-13UNC-2A X 1.75", STL ZINC PLTD, SAE J429	Blower Mounting
021-19307-010	NUT, HEX 3/8-16, ZINC PLATED	Lifting Lugs

Continued on next page

<b>FASTENERS FOR SOLUTION UNITS (CONTINUED)</b>		
<b>PART NUMBER</b>	<b>DESCRIPTION</b>	<b>WHERE USED</b>
021-19515-000	SCREW, SELF-DRILLING: 1/4 - 14 UN X 3/4 LG, STL ZINC PLATED	Fan Discharge Flex Connection
021-19556-000	SCR, HEX 1/2-13UNC-2A X 9" STL ZINC PLTD, SAE J429, ALL THREAD, OR EQUAL	Motor Base
021-19558-000	BLOCK, MOTOR BASE, 1/2-13 & 3/8-16 THRU HOLES	Motor Base
021-19559-000	SCR, CAP HEX 3/8 - 16 UNC - 2A X 5.0, STL ZINC PLATED	Snubber
021-19560-000	SCR, 1/4-14x1, PHIL PAN SELF DRILL	Self drill Screw for various locations when required
021-19567-000	PLUG, STEEL FINISHING TO FIT 3/4" ID HOLE	Top Corner Connector foam hole plug
021-19568-000	PLUG, STEEL FINISHING TO FIT 1-1/2" HOLE	Corner Connector lifting hole plug
021-19570-000	SCREW, HEX SOCKET BUTTON HEAD, 3/8 -16 X 3/4, STL ZINC PLATED	Lifting Lugs, Corners, Top split, stacking plate
021-19571-000	WASH LK TH INT 3/4 STL ZINC PLTD., STD. C-76	Blower Mounting
021-19579-000	NUT, RIVET KNURLED, #10-31, STL ZINC PLTD	Mounting Kit, Small MCC Panel
021-19580-000	NUT, RIVET KNURLED, 3/8-16, STL ZINC PLTD	Mounting Kit, Large MCC Panel
021-19581-000	SCR, CAP HEX 3/8 - 16 UNC - 2A X 2.5, STL ZINC PLTD	Mounting Kit, 2KVA Transformer
021-19582-000	SCR, PAN HD PHLPS, MACH, #10-32 X 1/2 LG, STL ZINC PLTD, WITH CAPTIVE INTERNAL TOOTH WASHER	Mounting Kit, 500VA / 150VA Control Transformer & Mounting Kit, Small MCC Panel
021-19585-000	SCREW, 1/4"-14 X 1", PHILLIPS PAN HD., SELF DRILLER W/WASHER, ZINC W/EPDM .25	Outdoor Unit Roof
021-19586-000	NUT, HEX 3/8-16, ZINC PLATED	Lifting Lugs
021-19587-000	RIVET, POP, 3/16"x3/8" GRIP, STL ZINC PLTD	RF Front or Rear Load Filter Tracks

<b>GASKET/CAULK/ADHESIVE FOR SOLUTION UNITS</b>		
<b>PART NUMBER</b>	<b>DESCRIPTION</b>	<b>WHERE USED</b>
010-01017-010	Caulk, Sikaflex, 221 SF, Sika Corp or Equal	Corner connectors & raceway; inside corners where corner connector, raceway and panels meet; wireway and bulkhead seal
010-02917-000	Ins Therm 1/8 x 1-1/2 x 50 Lg, Ind. Rolls C3-241-DC 221 White Ethafoam, W/psa, Std R749 DTD 10/8/90 Marriage Tape	Coil seal, bulk head seal
013-02966-011	Caulk, Manus-bond,75-am, Manus Products, or Equal	Corner connectors & raceway; inside corners where corner connector, raceway and panels meet; wireway and bulkhead seal
013-02976-010	Tape, Butyl, 0.75W x .19THK, TC-49 XI 121, Manus Products, or Equal	Outdoor units, between raceway 0.688 Flanges and panels/ roof/drain pan/pipe chase/control enclosure, panel to panel (vertical)
013-02977-010	Tape, Butyl, 1.5W x .13THK, TC-49 XI 121, Manus Products, or Equal	Outdoor units, between top raceways & along roof sides & between bottom raceways & curb rest
013-02978-010	Tape, Butyl, 0.5W x .13THK, TC-49 XI 121, Manus Products, or Equal	Outdoor unit doors along sides when door is between two panels
013-02979-010	Tape, Butyl, 0.5W x .25THK, TC-49 XI 121, Manus Products, or Equal	Outdoor units, between raceway 0.688 Flanges and roof
013-03317-010	Caulk, Solvent Free, Pace Gray or Equal, Sikaflex 221 SF or Manus-bond 75-AM	Corner connectors & raceway; inside corners where corner connector, raceway and panels meet; wireway and bulkhead seal
013-22013-010	Adhesive, Super Fast,#74, 3M or Equal	Fan flex connection
028-11778-010	Gasket, Neoprene, Closed Cell, B/G, 1.25W x 0.25THK, Scott Mfg or Equal	Split, bottom, sides, top panel to panel ends butt to butt
028-11791-010	Gasket, Polyurethane, Open Cell, B/G, 1.0W x 1.0THK, Scott Mfg or Equal	Filters
028-11861-000	GROMMET, SUPPLY/RETURN COIL HEADER, 1/8" PVC, For 3.00" CONNECTIONS	Coil Header Panel, For 3.00" Connections
028-11861-000	GROMMET, SUPPLY/RETURN COIL HEADER, 1/8" PVC	Coil Header Panel
028-11864-010	Gasket, Neoprene, Closed Cell, B/G, 0.75W x 0.5THK, Scott Mfg or Equal	Between vertical bulkheads and panel
028-11865-010	Foam, #2 Polyester, Open Cell, 2W x 2THK, 4LG, Scott Mfg or Equal	Wireway at pressure transitions.
028-11865-010	Gasket, Neoprene, Closed Cell, B/G, 1.0W x 2.0THK, Scott Mfg or Equal	Wireway at pressure transitions.
028-11866-001	Tape, Polyethylene, Double, 0.375W x 0.032THK, 5,184 In / Roll, or Equal	Between raceway double flange, between the liner flanges and out flanges of panels
028-11866-002	Tape, Polyethylene, Double, 0.375W x 0.032THK, Spool, 60,000 In / Spool, or Equal	Between raceway double flange, between the liner flanges and out flanges of panels
028-11866-010	Tape, Polyethylene, Double Sided, .38W x 0.13THK, Acrylic, Adhesive	Between raceway double flange, between the liner flanges and out flanges of panels
028-11867-010	Gasket, Neoprene, Closed Cell, B/G, 1.25W x .50THK, Scott Mfg or Equal	Between roof panels, type 8 filter tracks under the bulkhead
028-11871-000	Grommet, Supply/Return Coil Header, 1/8" PVC, for 2.50" And 2.00" Connections	Coil header panel, for 2.50" And 2.00" Connections
028-11872-000	Grommet, Supply/return Coil HEADER, 1/8" PVC, for 1.50", 1.25" And 1.00" Connections	Coil header panel, for 1.50", 1.25" And 1.00" Connections

Continued on next page

<b>GASKET/CAULK/ADHESIVE FOR SOLUTION UNITS (CONT.)</b>		
<b>PART NUMBER</b>	<b>DESCRIPTION</b>	<b>WHERE USED</b>
028-11873-010	Gasket, Neoprene, Closed Cell, Grey, .75W X .25THK, Scott Mfg or Equal	Panel to panel (vertical)
028-11875-010	Gasket, Ethafoam 221, Closed Cell, White, 1.5W X .13THK, Scott Mfg or Equal	Coil seal, bulk head seal
044-02912-000	Ultra Flex Elastomeric, #2260-0100(White) Coating: *an Expiration Date Required on This Product (Drain Pan)	Mastic coating for drain pan
044-02912-010	Coating, Ultra Flex Elastomeric, Mastic Coating for Drain Pan	Mastic coating for drain pan
1620	Gasket, Door, _____" High x _____" Wide	Door (see example below)
TAC01494	Standard Touchup Spray Paint, Dessert Sand	Outdoor unit exterior

Example For Ordering Door Gasket:

Door Is 35-1/2" High by 21-1/2" Wide

Order P/N 1620 35-1/2" High X 21-1/2" Wide.

DOOR LATCHING PARTS						
REF #	DOOR HT*	HANDLE**	LOCK	SWING	PART NUMBER	DESCRIPTION
1	SHORT OR TALL	STD OR SINGLE	STD	OUT	034-12001-001	Handle,Type_L,Lock_Non,Out-Swg,Roller_Straight,W/Screw & Cover Plug.
1	SHORT OR TALL	STD OR SINGLE	STD	IN	034-12001-006	Handle,Type_L,Lock_Non,In-Swg ,Roller_Off-Set,W/Screw & Cover Plug.
1	SHORT OR TALL	STD OR SINGLE	KEY	OUT	034-12001-007	Handle,Type_L,Lock_Key,Out-Swg,Roller_Straight,W/Screw & Cover Plug, Key The Same,York Std.
1	SHORT OR TALL	STD OR SINGLE	KEY	IN	034-12001-010	Handle,Type_L,Lock_Key,In-Swg , Roller_Off-Set,W/Screw & Cover Plug, Key The Same,York Std.
1	SHORT OR TALL	STD OR SINGLE	PAD	OUT	034-12001-011	Handle,Type_L,Lock_Pad,Out-Swg, Roller_Straight,W/Screw & Cover Plug.
1	SHORT OR TALL	STD OR SINGLE	PAD	IN	034-12001-012	Handle,Type_L,Lock_Pad,In-Swg ,Roller_Off-Set,W/Screw & Cover Plug.
1	SHORT OR TALL	SINGLE	KEY OR STD	IN OR OUT	034-12002-007	Plug, Cover For Latch Mechanism
2	SHORT OR TALL	N/A	N/A	N/A	034-12002-001	Mechanism, Latching,Includes Bushing, Lock nut, & Jam Nut.
3	SHORT OR TALL	N/A	N/A	N/A	034-12002-009	3/8 Sae Flat Washer
4	SHORT	OUT	N/A	N/A	034-12002-011	Single Point Roller Cam, Snub Nose Outswing Doors Only
5	SHORT OR TALL	SINGLE	N/A	N/A	034-12002-010	Linkage Adapter For 8 Mm (0.315") Dia Rods
6	SHORT OR TALL	STD OR SINGLE	N/A	N/A	034-12001-005	Inside Handle W/ Red Plastic Grip
7	SHORT OR TALL	SINGLE	N/A	OUT	034-12002-007	Cover Plug For Latching Mechanism For Single Point To Cover Outside Latching Mech.
8	20.88	SINGLE	N/A	N/A	086-02023-001	Rod 0.315" Dia 10" Long Zinc Plated
8	23.88	SINGLE	N/A	N/A	086-02023-002	Rod 0.315" Dia 13" Long Zinc Plated
8	26.88	SINGLE	N/A	N/A	086-02023-003	Rod 0.315" Dia 16" Long Zinc Plated
8	29.88	SINGLE	N/A	N/A	086-02023-004	Rod 0.315" Dia 19" Long Zinc Plated
8	32.88	SINGLE	N/A	N/A	086-02023-005	Rod 0.315" Dia 22" Long Zinc Plated
8	35.88	SINGLE	N/A	N/A	086-02023-006	Rod 0.315" Dia 25" Long Zinc Plated
8	38.88	SINGLE	N/A	N/A	086-02023-007	Rod 0.315" Dia 28" Long Zinc Plated
8	41.88	SINGLE	N/A	N/A	086-02023-008	Rod 0.315" Dia 31" Long Zinc Plated
8	44.88	SINGLE	N/A	N/A	086-02023-009	Rod 0.315" Dia 34" Long Zinc Plated
8	47.88	SINGLE	N/A	N/A	086-02023-010	Rod 0.315" Dia 37" Long Zinc Plated
8	50.88	SINGLE	N/A	N/A	086-02023-011	Rod 0.315" Dia 40" Long Zinc Plated
8	53.88	SINGLE	N/A	N/A	086-02023-012	Rod 0.315" Dia 43" Long Zinc Plated

Continued on next page

DOOR LATCHING PARTS (CONTINUED)						
REF #	DOOR HT*	HANDLE**	LOCK	SWING	PART NUMBER	DESCRIPTION
8	56.88	SINGLE	N/A	N/A	086-02023-013	Rod 0.315" Dia 46" Long Zinc Plated
8	59.88	SINGLE	N/A	N/A	086-02023-014	Rod 0.315" Dia 49" Long Zinc Plated
8	62.88	SINGLE	N/A	N/A	086-02023-015	Rod 0.315" Dia 52" Long Zinc Plated
8	65.88	SINGLE	N/A	N/A	086-02023-016	Rod 0.315" Dia 55" Long Zinc Plated
8	68.88	SINGLE	N/A	N/A	086-02023-017	Rod 0.315" Dia 58" Long Zinc Plated
8	71.88	SINGLE	N/A	N/A	086-02023-018	Rod 0.315" Dia 61" Long Zinc Plated
8	74.88	SINGLE	N/A	N/A	086-02023-019	Rod 0.315" Dia 64" Long Zinc Plated
8	77.88	SINGLE	N/A	N/A	086-02023-020	Rod 0.315" Dia 67" Long Zinc Plated
8	80.88	SINGLE	N/A	N/A	086-02023-021	Rod 0.315" Dia 70" Long Zinc Plated
8	83.88	SINGLE	N/A	N/A	086-02023-022	Rod 0.315" Dia 73" Long Zinc Plated
8	86.88	SINGLE	N/A	N/A	086-02023-023	Rod 0.315" Dia 76" Long Zinc Plated
8	89.88	SINGLE	N/A	N/A	086-02023-024	Rod 0.315" Dia 79" Long Zinc Plated
8	92.88	SINGLE	N/A	N/A	086-02023-025	Rod 0.315" Dia 82" Long Zinc Plated
8	95.88	SINGLE	N/A	N/A	086-02023-026	Rod 0.315" Dia 85" Long Zinc Plated
8	98.88	SINGLE	N/A	N/A	086-02023-027	Rod 0.315" Dia 88" Long Zinc Plated
8	101.88	SINGLE	N/A	N/A	086-02023-028	Rod 0.315" Dia 91" Long Zinc Plated
8	104.88	SINGLE	N/A	N/A	086-02023-029	Rod 0.315" Dia 94" Long Zinc Plated
8	107.88	SINGLE	N/A	N/A	086-02023-030	Rod 0.315" Dia 97" Long Zinc Plated
8	110.88	SINGLE	N/A	N/A	086-02023-031	Rod 0.315" Dia 100" Long Zinc Plated
8	113.88	SINGLE	N/A	N/A	086-02023-032	Rod 0.315" Dia 103" Long Zinc Plated
8	116.88	SINGLE	N/A	N/A	086-02023-033	Rod 0.315" Dia 106" Long Zinc Plated
8	119.88	SINGLE	N/A	N/A	086-02023-034	Rod 0.315" Dia 109" Long Zinc Plated
8	122.88	SINGLE	N/A	N/A	086-02023-035	Rod 0.315" Dia 112" Long Zinc Plated
8	125.88	SINGLE	N/A	N/A	086-02023-036	Rod 0.315" Dia 115" Long Zinc Plated
8	128.88	SINGLE	N/A	N/A	086-02023-037	Rod 0.315" Dia 118" Long Zinc Plated
9	SHORT OR TALL	STD OR SINGLE	N/A	N/A	386-02177-000	Kit, Latching Mechanism, Door , (Includes Ref. 2) (Order 2 Kits For Short Doors And 3 Kits For Tall Doors)
* Short door heights - 20.88" through 68.88" Tall door heights - 71.88" through 128.88"					** - Single is for "Single point multi-latch system". Standard is a complete latch and handle for each latching point.	

### DOOR GASKETS

Measure door dimensions to special order door gasket made with welded corners. See example in Table "GASKET/CAULK/ADHESIVE FOR SOLUTION UNITS" in this manual.

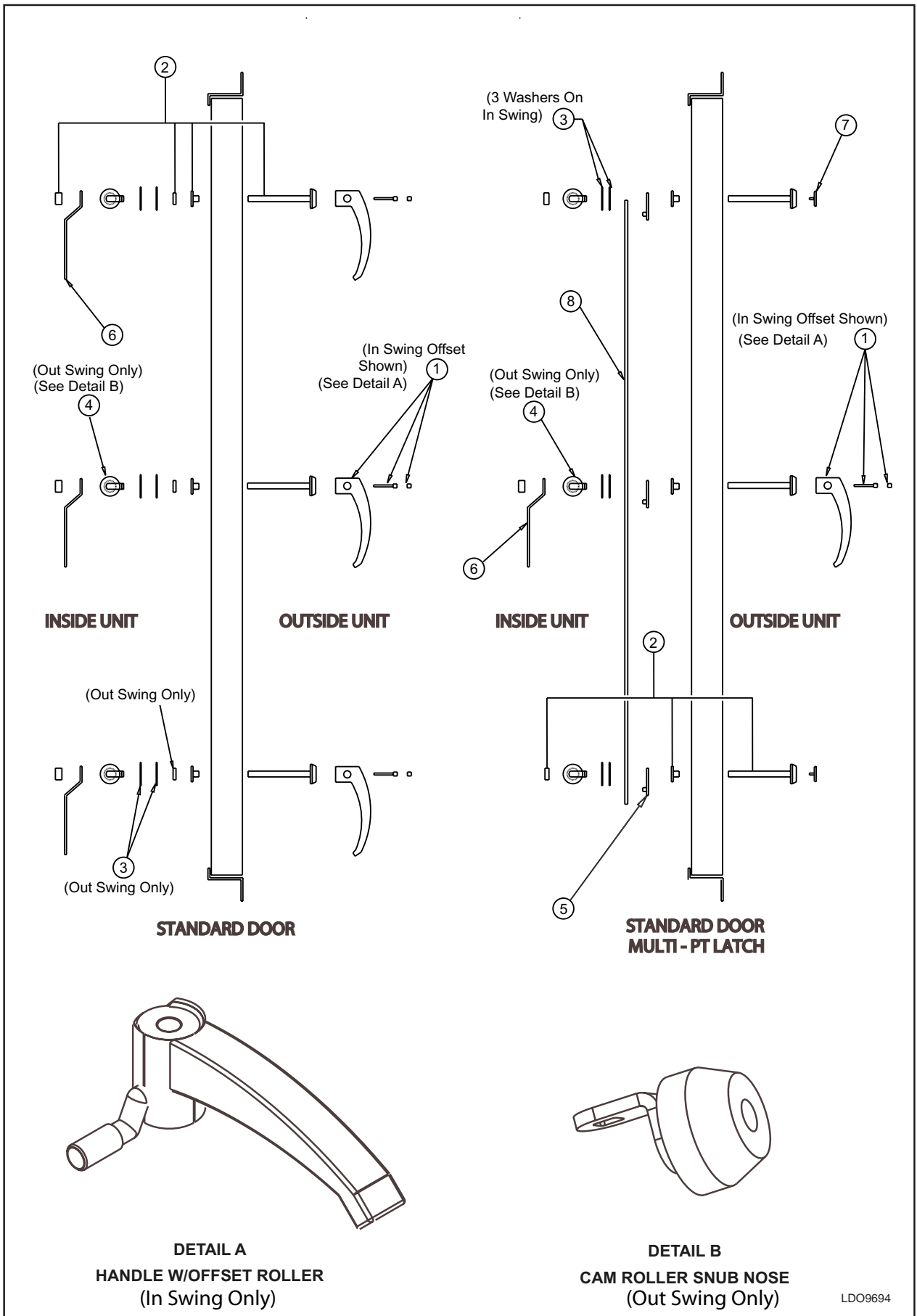

FIG. 2 - DOOR LATCHING PARTS

**THRUST RESTRAINT KIT SELECTION**

FAN TYPE	FAN SIZE	DISCHARGE	KIT PART NUMBER
AF	12-12	WALL	386-17791-002
AF	12-12	INSULATED PANEL	386-17791-010
AF	15-15	WALL	386-17791-002
AF	15-15	INSULATED PANEL	386-17791-011
AF	18-18	WALL	386-17791-002
AF	18-18	INSULATED PANEL	386-17791-012
AF	20-20	WALL	386-17791-002
AF	20-20	INSULATED PANEL	386-17791-013
AF	22-22	WALL	386-17791-007
AF	22-22	INSULATED PANEL	386-17791-014
AF	25-25	WALL	386-17791-007
AF	25-25	INSULATED PANEL	386-17791-015
AF	28-28	WALL	386-17791-008
AF	28-28	INSULATED PANEL	386-17791-016
AF	32-32	WALL	386-17791-008
AF	32-32	INSULATED PANEL	386-17791-017
AF	36-36	WALL	386-17791-009
AF	36-36	INSULATED PANEL	386-17791-018
AF	40-40	WALL	386-17791-006
AF	40-40	INSULATED PANEL	386-17791-019
IND	122	WALL	386-17791-002
IND	122	INSULATED PANEL	386-17791-020
IND	135	WALL	386-17791-002
IND	135	INSULATED PANEL	386-17791-021
IND	150	WALL	386-17791-002
IND	150	INSULATED PANEL	386-17791-022
IND	165	WALL	386-17791-002
IND	165	INSULATED PANEL	386-17791-023
IND	182	WALL	386-17791-002
IND	182	INSULATED PANEL	386-17791-024
IND	200	WALL	386-17791-002
IND	200	INSULATED PANEL	386-17791-025
IND	222	WALL	386-17791-007
IND	222	INSULATED PANEL	386-17791-026
IND	245	WALL	386-17791-007
IND	245	INSULATED PANEL	386-17791-027
IND	270	WALL	386-17791-008

FAN TYPE	FAN SIZE	DISCHARGE	KIT PART NUMBER
IND	270	INSULATED PANEL	386-17791-028
IND	300	WALL	386-17791-008
IND	300	INSULATED PANEL	386-17791-029
IND	330	WALL	386-17791-008
IND	330	INSULATED PANEL	386-17791-030
IND	365	WALL	386-17791-009
IND	365	INSULATED PANEL	386-17791-031
IND	402	WALL	386-17791-006
IND	402	INSULATED PANEL	386-17791-032
IND	445	WALL	386-17791-006
IND	445	INSULATED PANEL	386-17791-033
PLENUM	121	WALL	386-17791-001
PLENUM	141	WALL	386-17791-001
PLENUM	161	WALL	386-17791-001
PLENUM	181	WALL	386-17791-001
PLENUM	201	WALL	386-17791-001
PLENUM	221	WALL	386-17791-001
PLENUM	251	WALL	386-17791-001
PLENUM	281	WALL	386-17791-001
PLENUM	321	WALL	386-17791-001
PLENUM	351	WALL	386-17791-001
PLENUM	391	WALL	386-17791-003
PLENUM	441	WALL	386-17791-003
PLENUM	491	WALL	386-17791-004
PLENUM	551	WALL	386-17791-005
PLENUMDD	181	WALL	386-17791-001
PLENUMDD	201	WALL	386-17791-001
PLENUMDD	221	WALL	386-17791-001
PLENUMDD	251	WALL	386-17791-001
PLENUMDD	281	WALL	386-17791-001
PLENUMDD	321	WALL	386-17791-001
PLENUMDD	351	WALL	386-17791-001
PLENUMDD	391	WALL	386-17791-003
PLENUMDD	441	WALL	386-17791-003
PLENUMDD	491	WALL	386-17791-004
PLENUMDD	551	WALL	386-17791-005



**THRUST RESTRAINT KITS**

<b>P/N - 386-17791-001</b>		
<b>P/N</b>	<b>DESCRIPTION</b>	<b>QTY</b>
029-21364-001	RESTRAINT THRUST 350LBS/PR	2
086-01320-001	SMALL THRUST REST BRKT	2
<b>P/N - 386-17791-002</b>		
<b>P/N</b>	<b>DESCRIPTION</b>	<b>QTY</b>
029-21364-001	RESTRAINT THRUST 350LBS/PR	2
086-01322-002	THRUST RESTRAINT SST PLATE	2
086-01320-001	SMALL THRUST REST BRKT	2
<b>P/N - 386-17791-003</b>		
<b>P/N</b>	<b>DESCRIPTION</b>	<b>QTY</b>
029-21364-002	RESTRAINT THRUST 550LBS/PR	2
086-01320-001	SMALL THRUST REST BRKT	2
<b>P/N - 386-17791-004</b>		
<b>P/N</b>	<b>DESCRIPTION</b>	<b>QTY</b>
029-21364-003	RESTRAINT THRUST 750LBS/PR	2
086-01320-001	SMALL THRUST REST BRKT	2
<b>P/N - 386-17791-005</b>		
<b>P/N</b>	<b>DESCRIPTION</b>	<b>QTY</b>
029-21364-004	RESTRAINT THRUST 1500LBS/PR	2
086-01320-001	SMALL THRUST REST BRKT	2
<b>P/N - 386-17791-006</b>		
<b>P/N</b>	<b>DESCRIPTION</b>	<b>QTY</b>
029-21364-004	RESTRAINT THRUST 1500LBS/PR	2
086-01322-002	THRUST RESTRAINT SST PLATE	2
086-01320-002	LARGE THRUST REST BRKT	2
<b>P/N - 386-17791-007</b>		
<b>P/N</b>	<b>DESCRIPTION</b>	<b>QTY</b>
029-21364-001	RESTRAINT THRUST 350LBS/PR	2
086-01322-002	THRUST RESTRAINT SST PLATE	2
086-01320-002	LARGE THRUST REST BRKT	2
<b>P/N - 386-17791-008</b>		
<b>P/N</b>	<b>DESCRIPTION</b>	<b>QTY</b>
029-21364-002	RESTRAINT THRUST 550LBS/PR	2
086-01322-002	THRUST RESTRAINT SST PLATE	2
086-01320-002	LARGE THRUST REST BRKT	2
<b>P/N - 386-17791-009</b>		
<b>P/N</b>	<b>DESCRIPTION</b>	<b>QTY</b>
029-21364-003	RESTRAINT THRUST 750LBS/PR	2
086-01322-002	THRUST RESTRAINT SST PLATE	2
086-01320-002	LARGE THRUST REST BRKT	2
<b>P/N - 386-17791-010</b>		
<b>P/N</b>	<b>DESCRIPTION</b>	<b>QTY</b>
029-21364-001	RESTRAINT THRUST 350LBS/PR	2
086-01321-001	THRUST REST SUPPORT	2

086-01320-001	SMALL THRUST REST BRKT	2
<b>P/N - 386-17791-011</b>		
<b>P/N</b>	<b>DESCRIPTION</b>	<b>QTY</b>
029-21364-001	RESTRAINT THRUST 350LBS/PR	2
086-01321-002	THRUST REST SUPPORT	2
086-01320-001	SMALL THRUST REST BRKT	2
<b>P/N - 386-17791-012</b>		
<b>P/N</b>	<b>DESCRIPTION</b>	<b>QTY</b>
029-21364-001	RESTRAINT THRUST 350LBS/PR	2
086-01321-003	THRUST REST SUPPORT	2
086-01320-001	SMALL THRUST REST BRKT	2
<b>P/N - 386-17791-013</b>		
<b>P/N</b>	<b>DESCRIPTION</b>	<b>QTY</b>
029-21364-001	RESTRAINT THRUST 350LBS/PR	2
086-01321-004	THRUST REST SUPPORT	2
086-01320-001	SMALL THRUST REST BRKT	2
<b>P/N - 386-17791-014</b>		
<b>P/N</b>	<b>DESCRIPTION</b>	<b>QTY</b>
029-21364-001	RESTRAINT THRUST 350LBS/PR	2
086-01321-005	THRUST REST SUPPORT	2
086-01320-002	LARGE THRUST REST BRKT	2
<b>P/N - 386-17791-015</b>		
<b>P/N</b>	<b>DESCRIPTION</b>	<b>QTY</b>
029-21364-001	RESTRAINT THRUST 350LBS/PR	2
086-01321-006	THRUST REST SUPPORT	2
086-01320-002	LARGE THRUST REST BRKT	2
<b>P/N - 386-17791-016</b>		
<b>P/N</b>	<b>DESCRIPTION</b>	<b>QTY</b>
029-21364-002	RESTRAINT THRUST 550LBS/PR	2
086-01321-007	THRUST REST SUPPORT	2
086-01320-002	LARGE THRUST REST BRKT	2
<b>P/N - 386-17791-017</b>		
<b>P/N</b>	<b>DESCRIPTION</b>	<b>QTY</b>
029-21364-002	RESTRAINT THRUST 550LBS/PR	2
086-01321-008	THRUST REST SUPPORT	2
086-01320-002	LARGE THRUST REST BRKT	2
<b>P/N - 386-17791-018</b>		
<b>P/N</b>	<b>DESCRIPTION</b>	<b>QTY</b>
029-21364-003	RESTRAINT THRUST 750LBS/PR	2
086-01321-009	THRUST REST SUPPORT	2
086-01320-002	LARGE THRUST REST BRKT	2
<b>P/N - 386-17791-019</b>		
<b>P/N</b>	<b>DESCRIPTION</b>	<b>QTY</b>
029-21364-004	RESTRAINT THRUST 1500LBS/PR	2

Continued on next page

**THRUST RESTRAINT KITS (CONTINUED)**

086-01321-010	THRUST REST SUPPORT	2
086-01320-002	LARGE THRUST REST BRKT	2
<b>P/N - 386-17791-020</b>		
<b>P/N</b>	<b>DESCRIPTION</b>	<b>QTY</b>
029-21364-001	RESTRAINT THRUST 350LBS/PR	2
086-01321-011	THRUST REST SUPPORT	2
086-01320-001	SMALL THRUST REST BRKT	2
<b>P/N - 386-17791-021</b>		
<b>P/N</b>	<b>DESCRIPTION</b>	<b>QTY</b>
029-21364-001	RESTRAINT THRUST 350LBS/PR	2
086-01321-012	THRUST REST SUPPORT	2
086-01320-001	SMALL THRUST REST BRKT	2
<b>P/N - 386-17791-022</b>		
<b>P/N</b>	<b>DESCRIPTION</b>	<b>QTY</b>
029-21364-001	RESTRAINT THRUST 350LBS/PR	2
086-01321-013	THRUST REST SUPPORT	2
086-01320-001	SMALL THRUST REST BRKT	2
<b>P/N - 386-17791-023</b>		
<b>P/N</b>	<b>DESCRIPTION</b>	<b>QTY</b>
029-21364-001	RESTRAINT THRUST 350LBS/PR	2
086-01321-014	THRUST REST SUPPORT	2
086-01320-001	SMALL THRUST REST BRKT	2
<b>P/N - 386-17791-024</b>		
<b>P/N</b>	<b>DESCRIPTION</b>	<b>QTY</b>
029-21364-001	RESTRAINT THRUST 350LBS/PR	2
086-01321-015	THRUST REST SUPPORT	2
086-01320-001	SMALL THRUST REST BRKT	2
<b>P/N - 386-17791-025</b>		
<b>P/N</b>	<b>DESCRIPTION</b>	<b>QTY</b>
029-21364-001	RESTRAINT THRUST 350LBS/PR	2
086-01321-016	THRUST REST SUPPORT	2
086-01320-001	SMALL THRUST REST BRKT	2
<b>P/N - 386-17791-026</b>		
<b>P/N</b>	<b>DESCRIPTION</b>	<b>QTY</b>
029-21364-001	RESTRAINT THRUST 350LBS/PR	2
086-01321-017	THRUST REST SUPPORT	2
086-01320-002	LARGE THRUST REST BRKT	2
<b>P/N - 386-17791-027</b>		
<b>P/N</b>	<b>DESCRIPTION</b>	<b>QTY</b>
029-21364-001	RESTRAINT THRUST 350LBS/PR	2
086-01321-018	THRUST REST SUPPORT	2
086-01320-002	LARGE THRUST REST BRKT	2
<b>P/N - 386-17791-028</b>		
<b>P/N</b>	<b>DESCRIPTION</b>	<b>QTY</b>
029-21364-002	RESTRAINT THRUST 550LBS/PR	2
086-01321-019	THRUST REST SUPPORT	2

086-01320-002	LARGE THRUST REST BRKT	2
<b>P/N - 386-17791-029</b>		
<b>P/N</b>	<b>DESCRIPTION</b>	<b>QTY</b>
029-21364-002	RESTRAINT THRUST 550LBS/PR	2
086-01321-020	THRUST REST SUPPORT	2
086-01320-002	LARGE THRUST REST BRKT	2
<b>P/N - 386-17791-030</b>		
<b>P/N</b>	<b>DESCRIPTION</b>	<b>QTY</b>
029-21364-002	RESTRAINT THRUST 550LBS/PR	2
086-01321-021	THRUST REST SUPPORT	2
<b>P/N - 386-17791-031</b>		
<b>P/N</b>	<b>DESCRIPTION</b>	<b>QTY</b>
029-21364-003	RESTRAINT THRUST 750LBS/PR	2
086-01321-022	THRUST REST SUPPORT	2
086-01320-002	LARGE THRUST REST BRKT	2
<b>P/N - 386-17791-032</b>		
<b>P/N</b>	<b>DESCRIPTION</b>	<b>QTY</b>
029-21364-004	RESTRAINT THRUST 1500LBS/PR	2
086-01321-023	THRUST REST SUPPORT	2
086-01320-002	LARGE THRUST REST BRKT	2
<b>P/N - 386-17791-033</b>		
<b>P/N</b>	<b>DESCRIPTION</b>	<b>QTY</b>
029-21364-004	RESTRAINT THRUST 1500LBS/PR	2
086-01321-024	THRUST REST SUPPORT	2
086-01320-002	LARGE THRUST REST BRKT	2
<b>HARDWARE INCLUDED IN ALL KITS</b>		
<b>P/N</b>	<b>DESCRIPTION</b>	<b>QTY.</b>
021-01481-000	SCR, CAP HEX 3/8 - 16 UNC - 2A X 1.0, ZINC PLATED	4
021-01267-000	WASH FLT 7/16 ID X 1 OD X 0.083 THK STL ZINC PLTD.	8
021-01155-000	WASH, LK TH INT 3/8 STD C-76	4
021-19307-000	NUT, HEX LK 3/8-16 ZINC PLATED	4
021-19515-000	SCREW, SELF-DRILLING: 1/4 - 14 UN X 3/4 LG, ZINC PLATED	16

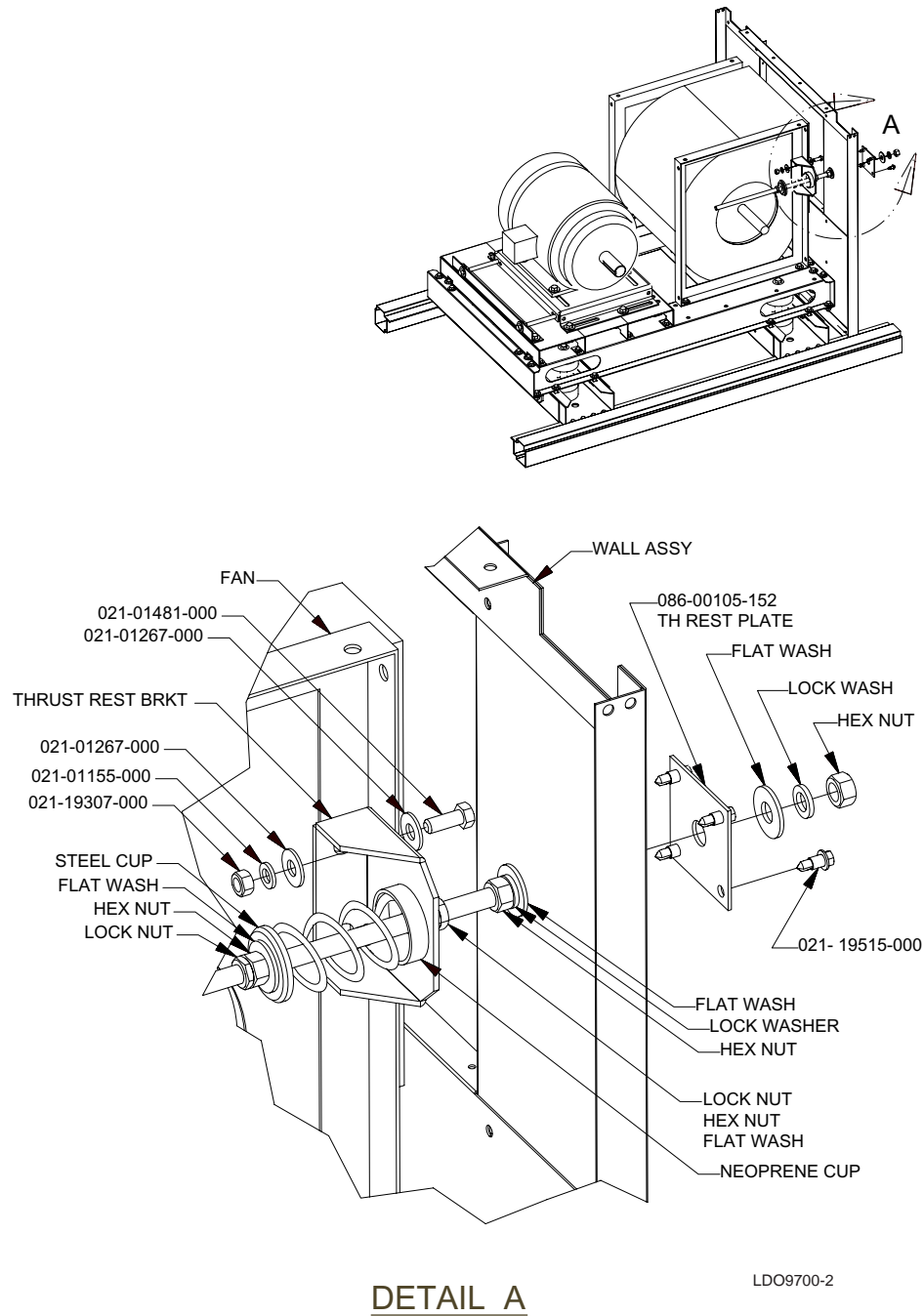
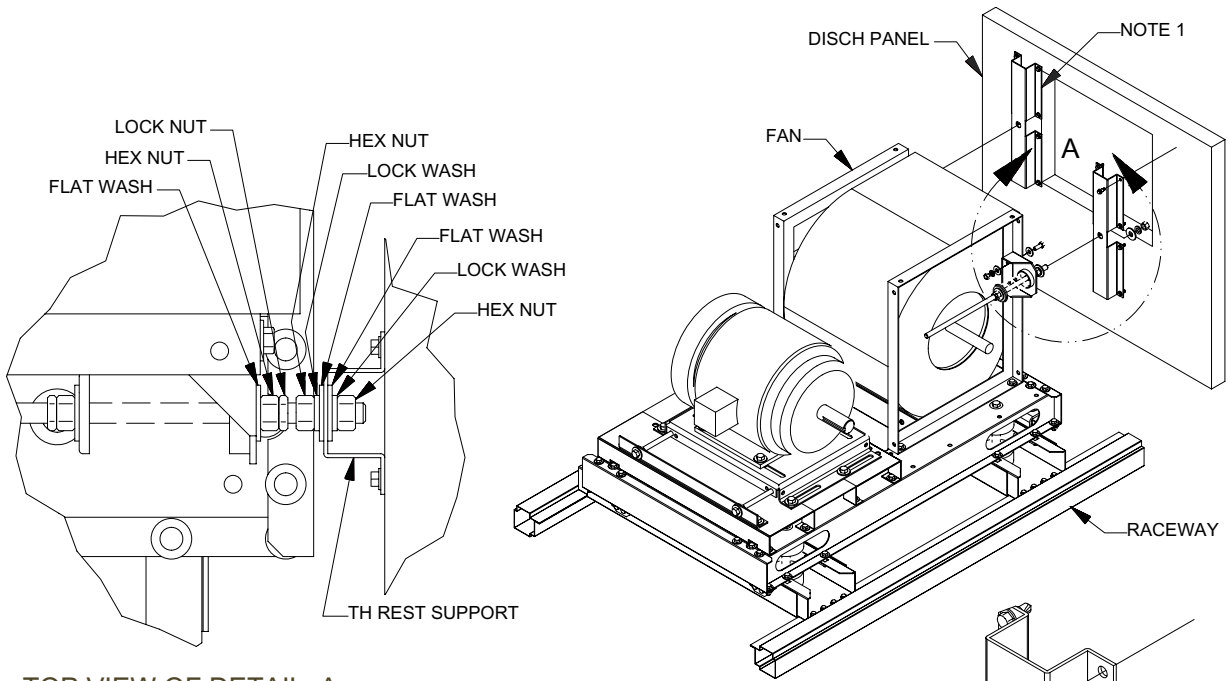
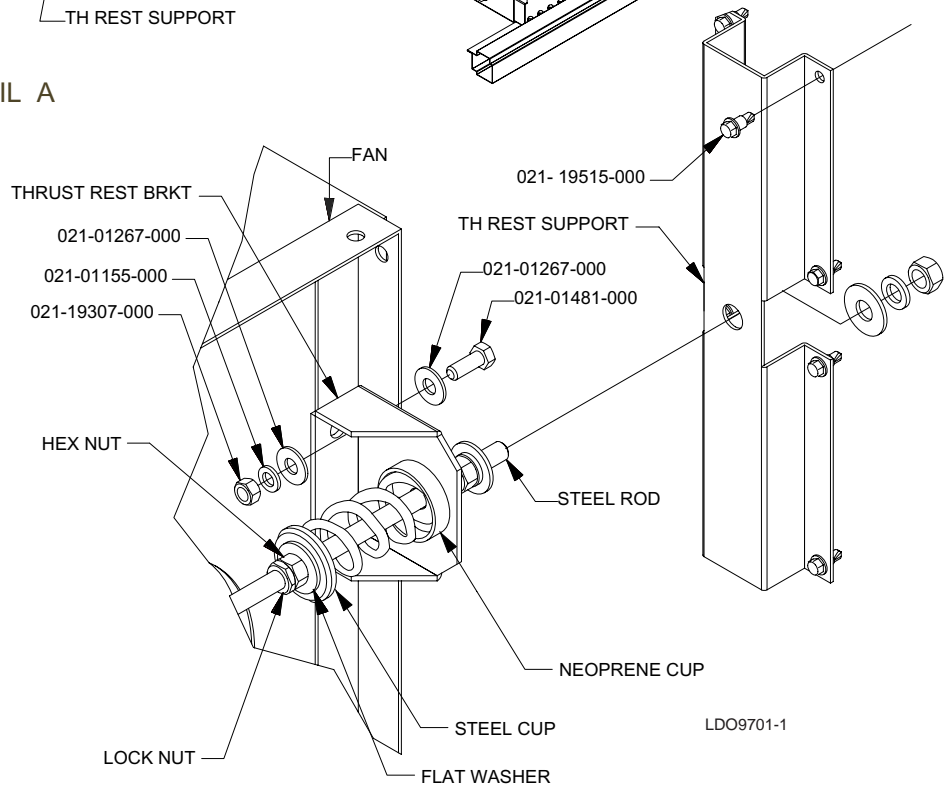

FIG. 3 - THRUST RESTRAINT INSTALLATION FOR COMEFRI AND INDUSTRIAL FANS DISCHARGING INTO WALLS



TOP VIEW OF DETAIL A



DETAIL A

1. TH REST SUPPORT FLANGE IS TO BE FLUSH WITH PANEL OPENING.

**FIG. 4 - THRUST RESTRAINT INSTALLATION FOR COMEFRI AND INDUSTRIAL FANS DISCHARGING INTO PANELS**

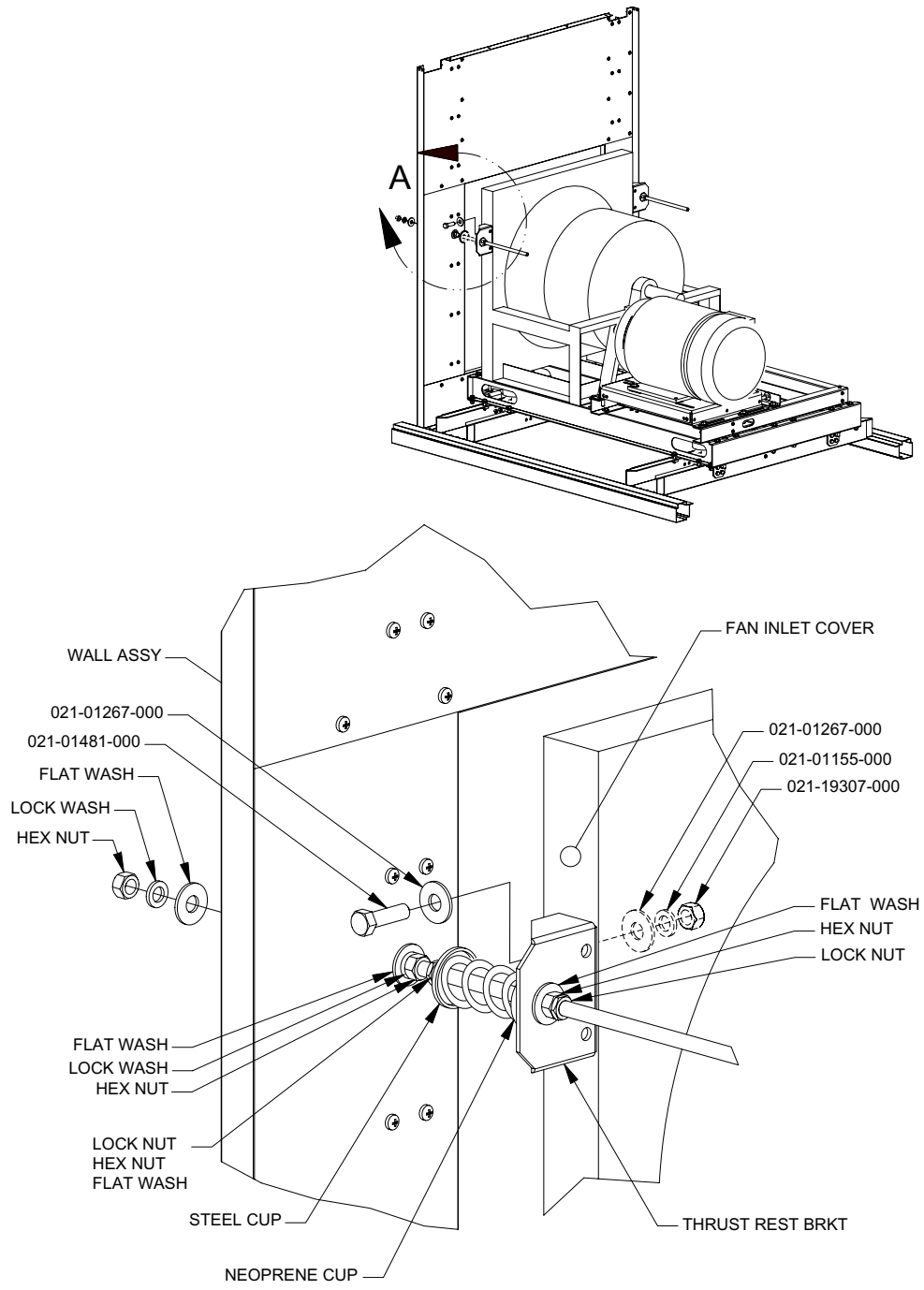

DETAIL A

FIG. 5 - THRUST RESTRAINT INSTALLATION FOR PLENUM FANS WITH WALL MOUNTED INLET

FAN MOTORS							
HERTZ	EFF	TYPE	VOLT.	HP	NOM-RPM	PART NUMBER	DESCRIPTION
60	HIGH	ODP	200	50	1800	024-14920-000	MTR 50HP 200/208-3-60 ODP HIGH 1800RPM BALDOR M2543T-8
60	HIGH	ODP	200	1.5	1800	024-23174-000	MTR 1.5HP 200/208-3-60 ODP HIGH 1800RPM BALDOR M3154T-8
60	HIGH	ODP	230/460	2	1800	024-23189-000	MTR 2HP 230/460-3-60 ODP HIGH 1800RPM BALDOR M3157T
60	HIGH	ODP	230/460	30	1800	024-23191-000	MTR 30HP 230/460-3-60 ODP HIGH 1800RPM BALDOR M2535T
60	HIGH	ODP	230/460	40	1800	024-23195-000	MTR 40HP 230/460-3-60 ODP HIGH 1800RPM BALDOR M2539T
60	HIGH	ODP	230/460	50	1800	024-23196-000	MTR 50HP 230/460-3-60 ODP HIGH 1800RPM BALDOR M2543T
60	HIGH	ODP	230/460	60	1800	024-23197-000	MTR 60HP 230/460-3-60 ODP HIGH 1800RPM BALDOR M2547T
60	HIGH	TEFC	230/460	3	1800	024-23914-000	MTR 3HP 230/460-3-60 TEFC HIGH 1800RPM BALDOR M3611T
60	HIGH	TEFC	230/460	5	1800	024-23915-000	MTR 5HP 230/460-3-60 TEFC HIGH 1800RPM BALDOR M3615T
60	HIGH	TEFC	230/460	7.5	1800	024-23916-000	MTR 7.5HP 230/460-3-60 TEFC HIGH 1800RPM BALDOR M3710T
60	HIGH	TEFC	230/460	10	1800	024-23917-000	MTR 10HP 230/460-3-60 TEFC HIGH 1800RPM BALDOR M3714T
60	HIGH	TEFC	230/460	15	1800	024-23918-000	MTR 15HP 230/460-3-60 TEFC HIGH 1800RPM BALDOR M2333T
60	HIGH	TEFC	230/460	20	1800	024-23919-000	MTR 20HP 230/460-3-60 TEFC HIGH 1800RPM BALDOR M2334T
60	HIGH	TEFC	230/460	25	1800	024-23920-000	MTR 25HP 230/460-3-60 TEFC HIGH 1800RPM BALDOR M4103T
60	HIGH	TEFC	200	3	1800	024-23921-000	MTR 3HP 200/208-3-60 TEFC HIGH 1800RPM BALDOR M3611T-8
60	HIGH	TEFC	200	5	1800	024-23922-000	MTR 5HP 200/208-3-60 TEFC HIGH 1800RPM BALDOR M3615T-8
60	HIGH	TEFC	200	7.5	1800	024-23923-000	MTR 7.5HP 200/208-3-60 TEFC HIGH 1800RPM BALDOR M3710T-8
60	HIGH	TEFC	200	10	1800	024-23924-000	MTR 10HP 200/208-3-60 TEFC HIGH 1800RPM BALDOR M3714T-8
60	HIGH	TEFC	200	15	1800	024-23925-000	MTR 15HP 200/208-3-60 TEFC HIGH 1800RPM BALDOR M2333T-8
60	HIGH	ODP	230/460	3	1800	024-23928-000	MTR 3HP 230/460-3-60 ODP HIGH 1800RPM BALDOR M3211T
60	HIGH	ODP	230/460	5	1800	024-23929-000	MTR 5HP 230/460-3-60 ODP HIGH 1800RPM BALDOR M3218T
60	HIGH	ODP	230/460	7.5	1800	024-23930-000	MTR 7.5HP 230/460-3-60 ODP HIGH 1800RPM BALDOR M3311T
60	HIGH	ODP	230/460	10	1800	024-23931-000	MTR 10HP 230/460-3-60 ODP HIGH 1800RPM BALDOR M3313T
60	HIGH	ODP	230/460	15	1800	024-23932-000	MTR 15HP 230/460-3-60 ODP HIGH 1800RPM BALDOR M2513T
60	HIGH	ODP	230/460	20	1800	024-23933-000	MTR 20HP 230/460-3-60 ODP HIGH 1800RPM BALDOR M2515T
60	HIGH	ODP	230/460	25	1800	024-23934-000	MTR 25HP 230/460-3-60 ODP HIGH 1800RPM BALDOR M2531T
60	HIGH	ODP	200	3	1800	024-23935-000	MTR 3HP 200/208-3-60 ODP HIGH 1800RPM BALDOR M3211T-8
60	HIGH	ODP	200	5	1800	024-23936-000	MTR 5HP 200/208-3-60 ODP HIGH 1800RPM BALDOR M3218T-8
60	HIGH	ODP	200	7.5	1800	024-23937-000	MTR 7.5HP 200/208-3-60 ODP HIGH 1800RPM BALDOR M3311T-8
60	HIGH	ODP	200	10	1800	024-23938-000	MTR 10HP 200/208-3-60 ODP HIGH 1800RPM BALDOR M3313T-8
60	HIGH	ODP	200	15	1800	024-23939-000	MTR 15HP 200/208-3-60 ODP HIGH 1800RPM BALDOR M2513T-8
60	HIGH	ODP	200	20	1800	024-23940-000	MTR 20HP 200/208-3-60 ODP HIGH 1800RPM BALDOR M2515T-8
60	HIGH	ODP	200	25	1800	024-23941-000	MTR 25HP 200/208-3-60 ODP HIGH 1800RPM BALDOR M2531T-8
50	HIGH	ODP	380	3	1500	024-26203-000	MTR 3HP 380-3-50 ODP HIGH 1500RPM BALDOR M3211T-50
50	HIGH	ODP	380	5	1500	024-26204-000	MTR 5HP 380-3-50 ODP HIGH 1500RPM BALDOR M3218T-50
50	HIGH	ODP	380	7.5	1500	024-26205-000	MTR 7.5HP 380-3-50 ODP HIGH 1500RPM BALDOR M3311T-50
50	HIGH	TEFC	380	10	1500	024-26221-000	MTR 10HP 380-3-50 TEFC HIGH 1500RPM BALDOR M3714T-50
50	HIGH	TEFC	380	15	1500	024-26252-000	MTR 15HP 380-3-50 TEFC HIGH 1500RPM BALDOR M2333T-50
60	HIGH	ODP	200	1	1800	024-26261-000	MTR 1HP 200/208-3-60 ODP HIGH 1800RPM BALDOR M3116T-8
60	HIGH	ODP	230/460	1	1800	024-26262-000	MTR 1HP 230/460-3-60 ODP HIGH 1800RPM BALDOR M3116T
60	HIGH	ODP	230/460	1.5	1800	024-26263-000	MTR 1.5HP 230/460-3-60 ODP HIGH 1800RPM BALDOR M3154T
60	HIGH	ODP	200	2	1800	024-26264-000	MTR 2HP 200/208-3-60 ODP HIGH 1800RPM BALDOR M3157T-8
60	HIGH	ODP	200	30	1800	024-26265-000	MTR 30HP 200/208-3-60 ODP HIGH 1800RPM BALDOR M2535T-8
60	HIGH	ODP	200	40	1800	024-26266-000	MTR 40HP 200/208-3-60 ODP HIGH 1800RPM BALDOR M2539T-8
60	HIGH	ODP	230/460	75	1800	024-26267-000	MTR 75HP 230/460-3-60 ODP HIGH 1800RPM BALDOR M2551T
60	HIGH	ODP	230/460	100	1800	024-26268-000	MTR 100HP 230/460-3-60 ODP HIGH 1800RPM BALDOR M2555T
60	HIGH	TEFC	200	30	1800	024-26271-000	MTR 30HP 200/208-3-60 TEFC HIGH 1800RPM BALDOR M4104T-8

Continued on next page

FAN MOTORS (CONTINUED)							
HERTZ	EFF	TYPE	VOLT.	HP	NOM RPM	PART NUMBER	DESCRIPTION
60	HIGH	TEFC	200	1	1800	024-26276-000	MTR 1HP 200/208-3-60 TEFC HIGH 1800RPM BALDOR M3546T-8
60	HIGH	TEFC	230/460	1	1800	024-26277-000	MTR 1HP 230/460-3-60 TEFC HIGH 1800RPM BALDOR M3546T
60	HIGH	TEFC	200	1.5	1800	024-26278-000	MTR 1.5HP 200/208-3-60 TEFC HIGH 1800RPM BALDOR M3554T-8
60	HIGH	TEFC	230/460	1.5	1800	024-26279-000	MTR 1.5HP 230/460-3-60 TEFC HIGH 1800RPM BALDOR M3554T
60	HIGH	TEFC	200	2	1800	024-26280-000	MTR 2HP 200/208-3-60 TEFC HIGH 1800RPM BALDOR M3558T-8
60	HIGH	TEFC	230/460	2	1800	024-26281-000	MTR 2HP 230/460-3-60 TEFC HIGH 1800RPM BALDOR M3558T
60	HIGH	TEFC	230/460	30	1800	024-26282-000	MTR 30HP 230/460-3-60 TEFC HIGH 1800RPM BALDOR M4104T
60	HIGH	TEFC	230/460	40	1800	024-26283-000	MTR 40HP 230/460-3-60 TEFC HIGH 1800RPM BALDOR M4110T
60	HIGH	TEFC	230/460	50	1800	024-26284-000	MTR 50HP 230/460-3-60 TEFC HIGH 1800RPM BALDOR M4115T
60	HIGH	TEFC	230/460	60	1800	024-26285-000	MTR 60HP 230/460-3-60 TEFC HIGH 1800RPM BALDOR M4314T
60	HIGH	TEFC	230/460	75	1800	024-26286-000	MTR 75HP 230/460-3-60 TEFC HIGH 1800RPM BALDOR M4316T
60	HIGH	TEFC	230/460	100	1800	024-26287-000	MTR 100HP 230/460-3-60 TEFC HIGH 1800RPM BALDOR M4400T
60	HIGH	ODP	575	1	1800	024-27005-000	MTR 1HP 575-3-60 ODP HIGH 1800RPM BALDOR M3116T-5
60	HIGH	ODP	575	1.5	1800	024-27006-000	MTR 1.5HP 575-3-60 ODP HIGH 1800RPM BALDOR M3154T-5
60	HIGH	ODP	575	2	1800	024-27007-000	MTR 2HP 575-3-60 ODP HIGH 1800RPM BALDOR M3157T-5
60	HIGH	ODP	575	3	1800	024-27008-000	MTR 3HP 575-3-60 ODP HIGH 1800RPM BALDOR M3211T-5
60	HIGH	ODP	575	5	1800	024-27009-000	MTR 5HP 575-3-60 ODP HIGH 1800RPM BALDOR M3218T-5
60	HIGH	ODP	575	7.5	1800	024-27010-000	MTR 7.5HP 575-3-60 ODP HIGH 1800RPM BALDOR M3311T-5
60	HIGH	ODP	575	10	1800	024-27011-000	MTR 10HP 575-3-60 ODP HIGH 1800RPM BALDOR M3313T-5
60	HIGH	ODP	575	15	1800	024-27012-000	MTR 15HP 575-3-60 ODP HIGH 1800RPM BALDOR M2513T-5
60	HIGH	ODP	575	20	1800	024-27013-000	MTR 20HP 575-3-60 ODP HIGH 1800RPM BALDOR M2515T-5
60	HIGH	ODP	575	25	1800	024-27014-000	MTR 25HP 575-3-60 ODP HIGH 1800RPM BALDOR M2531T-5
60	HIGH	ODP	575	30	1800	024-27015-000	MTR 30HP 575-3-60 ODP HIGH 1800RPM BALDOR M2535T-5
60	HIGH	ODP	575	40	1800	024-27016-000	MTR 40HP 575-3-60 ODP HIGH 1800RPM BALDOR M2539T-5
60	HIGH	ODP	575	50	1800	024-27017-000	MTR 50HP 575-3-60 ODP HIGH 1800RPM BALDOR M2543T-5
60	HIGH	ODP	575	60	1800	024-27018-000	MTR 60HP 575-3-60 ODP HIGH 1800RPM BALDOR M2547T-5
60	HIGH	ODP	575	75	1800	024-27019-000	MTR 75HP 575-3-60 ODP HIGH 1800RPM BALDOR M2551T-5
60	HIGH	ODP	575	100	1800	024-27020-000	MTR 100HP 575-3-60 ODP HIGH 1800RPM BALDOR M2555T-5
60	HIGH	TEFC	575	1	1800	024-27037-000	MTR 1HP 575-3-60 TEFC HIGH 1800RPM BALDOR M3546T-5
60	HIGH	TEFC	575	1.5	1800	024-27038-000	MTR 1.5HP 575-3-60 TEFC HIGH 1800RPM BALDOR M3554T-5
60	HIGH	TEFC	575	2	1800	024-27039-000	MTR 2HP 575-3-60 TEFC HIGH 1800RPM BALDOR M3558T-5
60	HIGH	TEFC	575	3	1800	024-27040-000	MTR 3HP 575-3-60 TEFC HIGH 1800RPM BALDOR M3611T-5
60	HIGH	TEFC	575	5	1800	024-27041-000	MTR 5HP 575-3-60 TEFC HIGH 1800RPM BALDOR M3615T-5
60	HIGH	TEFC	575	7.5	1800	024-27042-000	MTR 7.5HP 575-3-60 TEFC HIGH 1800RPM BALDOR M3710T-5
60	HIGH	TEFC	575	10	1800	024-27043-000	MTR 10HP 575-3-60 TEFC HIGH 1800RPM BALDOR M3714T-5
60	HIGH	TEFC	575	15	1800	024-27044-000	MTR 15HP 575-3-60 TEFC HIGH 1800RPM BALDOR M2333T-5
60	HIGH	TEFC	575	20	1800	024-27045-000	MTR 20HP 575-3-60 TEFC HIGH 1800RPM BALDOR M2334T-5
60	HIGH	TEFC	575	25	1800	024-27046-000	MTR 25HP 575-3-60 TEFC HIGH 1800RPM BALDOR M4103T-5
60	HIGH	TEFC	575	30	1800	024-27047-000	MTR 30HP 575-3-60 TEFC HIGH 1800RPM BALDOR M4104T-5
60	HIGH	TEFC	575	40	1800	024-27048-000	MTR 40HP 575-3-60 TEFC HIGH 1800RPM BALDOR M4110T-5
60	HIGH	TEFC	575	50	1800	024-27049-000	MTR 50HP 575-3-60 TEFC HIGH 1800RPM BALDOR M4115T-5
60	HIGH	TEFC	575	60	1800	024-27050-000	MTR 60HP 575-3-60 TEFC HIGH 1800RPM BALDOR M4314T-5
60	HIGH	TEFC	575	75	1800	024-27051-000	MTR 75HP 575-3-60 TEFC HIGH 1800RPM BALDOR M4316T-5
60	HIGH	TEFC	575	100	1800	024-27052-000	MTR 100HP 575-3-60 TEFC HIGH 1800RPM BALDOR M4400T-5
60	PREM	ODP	200	3	1800	024-27054-000	MTR 3HP 200/208-3-60 ODP PREM 1800RPM BALDOR EM3211T-8
60	PREM	ODP	460	3	1800	024-27055-000	MTR 3HP 460-3-60 ODP PREM 1800RPM BALDOR EM3211T
60	PREM	ODP	230/460	3	1800	024-27055-000	MTR 3HP 230/460-3-60 ODP PREM 1800RPM BALDOR EM3211T

Continued on next page

FAN MOTORS (CONTINUED)							
HERTZ	EFF	TYPE	VOLT.	HP	NOM RPM	PART NUMBER	DESCRIPTION
60	PREM	ODP	200	5	1800	024-27056-000	MTR 5HP 200/208-3-60 ODP PREM 1800RPM BALDOR EM3218T-8
60	PREM	ODP	230/460	5	1800	024-27057-000	MTR 5HP 230/460-3-60 ODP PREM 1800RPM BALDOR EM3218T
60	PREM	ODP	200	7.5	1800	024-27058-000	MTR 7.5HP 200/208-3-60 ODP PREM 1800RPM BALDOR EM3311T-8
60	PREM	ODP	230/460	7.5	1800	024-27059-000	MTR 7.5HP 230/460-3-60 ODP PREM 1800RPM BALDOR EM3311T
60	PREM	ODP	200	10	1800	024-27060-000	MTR 10HP 200/208-3-60 ODP PREM 1800RPM BALDOR EM3313T-8
60	PREM	ODP	230/460	10	1800	024-27062-000	MTR 10HP 230/460-3-60 ODP PREM 1800RPM BALDOR EM3313T
60	PREM	ODP	200	15	1800	024-27063-000	MTR 15HP 200/208-3-60 ODP PREM 1800RPM BALDOR EM2513T-8
60	PREM	ODP	230/460	15	1800	024-27064-000	MTR 15HP 230/460-3-60 ODP PREM 1800RPM BALDOR EM2513T
60	PREM	ODP	200	20	1800	024-27065-000	MTR 20HP 200/208-3-60 ODP PREM 1800RPM BALDOR EM2515T-8
60	PREM	ODP	230/460	20	1800	024-27066-000	MTR 20HP 230/460-3-60 ODP PREM 1800RPM BALDOR EM2515T
60	PREM	ODP	200	25	1800	024-27067-000	MTR 25HP 200/208-3-60 ODP PREM 1800RPM BALDOR EM2531T-8
60	PREM	ODP	230/460	25	1800	024-27068-000	MTR 25HP 230/460-3-60 ODP PREM 1800RPM BALDOR EM2531T
60	PREM	ODP	200	30	1800	024-27069-000	MTR 30HP 200/208-3-60 ODP PREM 1800RPM BALDOR EM2535T-8
60	PREM	ODP	230/460	30	1800	024-27070-000	MTR 30HP 230/460-3-60 ODP PREM 1800RPM BALDOR EM2535T
60	PREM	ODP	200	40	1800	024-27071-000	MTR 40HP 200/208-3-60 ODP PREM 1800RPM BALDOR EM2539T-8
60	PREM	ODP	230/460	40	1800	024-27072-000	MTR 40HP 230/460-3-60 ODP PREM 1800RPM BALDOR EM2539T
60	PREM	ODP	200	50	1800	024-27073-000	MTR 50HP 200/208-3-60 ODP PREM 1800RPM BALDOR EM2543T-8
60	PREM	ODP	230/460	50	1800	024-27074-000	MTR 50HP 230/460-3-60 ODP PREM 1800RPM BALDOR EM2543T
60	PREM	ODP	200	60	1800	024-27075-000	MTR 60HP 200/208-3-60 ODP PREM 1800RPM BALDOR EM2547T-8
60	PREM	ODP	230/460	60	1800	024-27076-000	MTR 60HP 230/460-3-60 ODP PREM 1800RPM BALDOR EM2547T
60	PREM	ODP	200	75	1800	024-27077-000	MTR 75HP 200/208-3-60 ODP PREM 1800RPM BALDOR EM2551T-8
60	PREM	ODP	230/460	75	1800	024-27078-000	MTR 75HP 230/460-3-60 ODP PREM 1800RPM BALDOR EM2551T
60	PREM	ODP	200	100	1800	024-27079-000	MTR 100HP 200/208-3-60 ODP PREM 1800RPM BALDOR EM2555T-8
60	PREM	ODP	460	100	1800	024-27080-000	MTR 100HP 460-3-60 ODP PREM 1800RPM BALDOR EM2555T-4
60	PREM	TEFC	200	3	1800	024-27081-000	MTR 3HP 200/208-3-60 TEFC PREM 1800RPM BALDOR EM3661T-8
60	PREM	TEFC	230/460	3	1800	024-27082-000	MTR 3HP 230/460-3-60 TEFC PREM 1800RPM BALDOR EM3611T
60	PREM	TEFC	200	5	1800	024-27083-000	MTR 5HP 200/208-3-60 TEFC PREM 1800RPM BALDOR EM3665T-8
60	PREM	TEFC	230/460	5	1800	024-27084-000	MTR 5HP 230/460-3-60 TEFC PREM 1800RPM BALDOR EM3615T
60	PREM	TEFC	200	7.5	1800	024-27085-000	MTR 7.5HP 200/208-3-60 TEFC PREM 1800RPM BALDOR EM3770T-8
60	PREM	TEFC	230/460	7.5	1800	024-27086-000	MTR 7.5HP 230/460-3-60 TEFC PREM 1800RPM BALDOR EM3710T
60	PREM	TEFC	200	10	1800	024-27087-000	MTR 10HP 200/208-3-60 TEFC PREM 1800RPM BALDOR EM3774T-8
60	PREM	TEFC	230/460	10	1800	024-27088-000	MTR 10HP 230/460-3-60 TEFC PREM 1800RPM BALDOR EM3714T
60	PREM	TEFC	200	15	1800	024-27089-000	MTR 15HP 200/208-3-60 TEFC PREM 1800RPM BALDOR EM2333T-8
60	PREM	TEFC	230/460	15	1800	024-27090-000	MTR 15HP 230/460-3-60 TEFC PREM 1800RPM BALDOR EM2333T
60	PREM	TEFC	200	20	1800	024-27097-000	MTR 20HP 200/208-3-60 TEFC PREM 1800RPM BALDOR EM2334T-8
60	PREM	TEFC	230/460	20	1800	024-27098-000	MTR 20HP 230/460-3-60 TEFC PREM 1800RPM BALDOR EM2334T
60	PREM	TEFC	200	25	1800	024-27099-000	MTR 25HP 200/208-3-60 TEFC PREM 1800RPM BALDOR EM4103T-8
60	PREM	TEFC	230/460	25	1800	024-27300-000	MTR 25HP 230/460-3-60 TEFC PREM 1800RPM BALDOR EM4103T
60	PREM	TEFC	230/460	30	1800	024-27301-000	MTR 30HP 230/460-3-60 TEFC PREM 1800RPM BALDOR EM4104T
60	PREM	TEFC	230/460	40	1800	024-27302-000	MTR 40HP 230/460-3-60 TEFC PREM 1800RPM BALDOR EM4110T
60	PREM	TEFC	230/460	50	1800	024-27303-000	MTR 50HP 230/460-3-60 TEFC PREM 1800RPM BALDOR EM4115T
60	PREM	TEFC	230/460	60	1800	024-27304-000	MTR 60HP 230/460-3-60 TEFC PREM 1800RPM BALDOR EM4314T
60	PREM	TEFC	230/460	75	1800	024-27305-000	MTR 75HP 230/460-3-60 TEFC PREM 1800RPM BALDOR EM4316T
60	PREM	TEFC	460	100	1800	024-27306-000	MTR 100HP 460-3-60 TEFC PREM 1800RPM BALDOR ECP4400T-4
60	PREM	TEFC	575	1	1800	024-27307-000	MTR 1HP 575-3-60 TEFC PREM 1800RPM BALDOR EM3546T-5
60	PREM	TEFC	575	1.5	1800	024-27308-000	MTR 1.5HP 575-3-60 TEFC PREM 1800RPM BALDOR EM3554T-5
60	PREM	TEFC	575	2	1800	024-27309-000	MTR 2HP 575-3-60 TEFC PREM 1800RPM BALDOR EM3558T-5

Continued on next page



FAN MOTORS (CONTINUED)							
HERTZ	EFF	TYPE	VOLT.	HP	NOM RPM	PART NUMBER	DESCRIPTION
60	PREM	TEFC	575	3	1800	024-27310-000	MTR 3HP 575-3-60 TEFC PREM 1800RPM BALDOR EM3611T-5
60	PREM	TEFC	575	5	1800	024-27311-000	MTR 5HP 575-3-60 TEFC PREM 1800RPM BALDOR EM3615T-5
60	PREM	TEFC	575	7.5	1800	024-27312-000	MTR 7.5HP 575-3-60 TEFC PREM 1800RPM BALDOR EM3710T-5
60	PREM	TEFC	575	10	1800	024-27313-000	MTR 10HP 575-3-60 TEFC PREM 1800RPM BALDOR. EM3714T-5
60	PREM	TEFC	575	15	1800	024-27314-000	MTR 15HP 575-3-60 TEFC PREM 1800RPM BALDOR EM2333T-5
60	PREM	TEFC	575	25	1800	024-27316-000	MTR 25HP 575-3-60 TEFC PREM 1800RPM BALDOR ECP4103T-5
60	PREM	ODP	230/460	1	1800	024-34400-000	MTR 1HP 230/460-3-60 ODP PREM 1800RPM BALDOR EM3116T
60	PREM	ODP	575	1	1800	024-34402-000	MTR 1HP 575-3-60 ODP PREM 1800RPM BALDOR EM3116T-5
60	PREM	ODP	200	1	1800	024-34403-000	MTR 1HP 200/208-3-60 ODP PREM 1800RPM BALDOR EM3116T-8
60	PREM	TEFC	230/460	1	1800	024-34404-000	MTR 1HP 230/460-3-60 TEFC PREM 1800RPM BALDOR EM3546T
60	PREM	TEFC	200	1	1800	024-34406-000	MTR 1HP 200/208-3-60 TEFC PREM 1800RPM BALDOR EM3546T-8
60	PREM	ODP	230/460	2	1800	024-34407-000	MTR 2HP 230/460-3-60 ODP PREM 1800RPM BALDOR EM3157T
60	PREM	ODP	575	2	1800	024-34409-000	MTR 2HP 575-3-60 ODP PREM 1800RPM BALDOR EM3157T-5
60	PREM	ODP	200	2	1800	024-34410-000	MTR 2HP 200/208-3-60 ODP PREM 1800RPM BALDOR EM3157T-8
60	PREM	TEFC	230/460	2	1800	024-34411-000	MTR 2HP 230/460-3-60 TEFC PREM 1800RPM BALDOR EM3558T
60	PREM	TEFC	200	2	1800	024-34413-000	MTR 2HP 200/208-3-60 TEFC PREM 1800RPM BALDOR EM3558T-8
60	PREM	ODP	575	3	1800	024-34414-000	MTR 3HP 575-3-60 ODP PREM 1800RPM BALDOR EM3211T-5
60	PREM	ODP	575	5	1800	024-34415-000	MTR 5HP 575-3-60 ODP PREM 1800RPM BALDOR EM3218T-5
60	PREM	ODP	575	7.5	1800	024-34416-000	MTR 7.5HP 575-3-60 ODP PREM 1800RPM BALDOR EM3311T-5
60	PREM	ODP	575	10	1800	024-34417-000	MTR 10HP 575-3-60 ODP PREM 1800RPM BALDOR EM3313T-5
60	PREM	ODP	230/460	1.5	1800	024-34419-000	MTR 1.5HP 230/460-3-60 ODP PREM 1800RPM BALDOR EM3154T
60	PREM	ODP	575	1.5	1800	024-34420-000	MTR 1.5HP 575-3-60 ODP PREM 1800RPM BALDOR EM3154T-5
60	PREM	ODP	200	1.5	1800	024-34421-000	MTR 1.5HP 200/208-3-60 ODP PREM 1800RPM BALDOR EM3154T-8
60	PREM	TEFC	230/460	1.5	1800	024-34423-000	MTR 1.5HP 230/460-3-60 TEFC PREM 1800RPM BALDOR EM3554T
60	PREM	TEFC	200	1.5	1800	024-34424-000	MTR 1.5HP 200/208-3-60 TEFC PREM 1800RPM BALDOR EM3554T-8
60	PREM	ODP	575	15	1800	024-34425-000	MTR 15HP 575-3-60 ODP PREM 1800RPM BALDOR EM2513T-5
60	HIGH	TEFC	200	20	1800	024-34426-000	MTR 20HP 200/208-3-60 TEFC HIGH 1800RPM BALDOR M2334T-8
60	PREM	ODP	575	20	1800	024-34427-000	MTR 20HP 575-3-60 ODP PREM 1800RPM BALDOR EM2515T-5
60	PREM	TEFC	575	20	1800	024-34428-000	MTR 20HP 575-3-60 TEFC PREM 1800RPM BALDOR ECP2334T-5
60	HIGH	TEFC	200	25	1800	024-34429-000	MTR 25HP 200/208-3-60 TEFC HIGH 1800RPM BALDOR M4103T-8
60	PREM	ODP	575	25	1800	024-34430-000	MTR 25HP 575-3-60 ODP PREM 1800RPM BALDOR EM2531T-5
60	PREM	ODP	575	30	1800	024-34431-000	MTR 30HP 575-3-60 ODP PREM 1800RPM BALDOR EM2535T-5
60	PREM	TEFC	575	30	1800	024-34432-000	MTR 30HP 575-3-60 TEFC PREM 1800RPM BALDOR ECP4104T-5
60	PREM	TEFC	200	30	1800	024-34433-000	MTR 30HP 200/208-3-60 TEFC PREM 1800RPM BALDOR EM4104T-8
60	HIGH	TEFC	200	40	1800	024-34434-000	MTR 40HP 200/208-3-60 TEFC HIGH 1800RPM BALDOR M4110T-8
60	PREM	ODP	575	40	1800	024-34435-000	MTR 40HP 575-3-60 ODP PREM 1800RPM BALDOR EM2539T-5
60	PREM	TEFC	575	40	1800	024-34436-000	MTR 40HP 575-3-60 TEFC PREM 1800RPM BALDOR ECP4110T-5
60	PREM	TEFC	200	40	1800	024-34437-000	MTR 40HP 200/208-3-60 TEFC PREM 1800RPM BALDOR EM4110T-8
60	HIGH	TEFC	200	50	1800	024-34438-000	MTR 50HP 200/208-3-60 TEFC HIGH 1800RPM BALDOR M4115T-8
60	PREM	ODP	575	50	1800	024-34439-000	MTR 50HP 575-3-60 ODP PREM 1800RPM BALDOR EM2543T-5
60	PREM	TEFC	575	50	1800	024-34440-000	MTR 50HP 575-3-60 TEFC PREM 1800RPM BALDOR ECP4115T-5
60	PREM	TEFC	200	50	1800	024-34441-000	MTR 50HP 200/208-3-60 TEFC PREM 1800RPM BALDOR EM4115T-8
60	HIGH	ODP	200	60	1800	024-34442-000	MTR 60HP 200/208-3-60 ODP HIGH 1800RPM BALDOR M2547T-8
60	HIGH	TEFC	200	60	1800	024-34443-000	MTR 60HP 200/208-3-60 TEFC HIGH 1800RPM BALDOR CUSTOM
60	PREM	ODP	575	60	1800	024-34444-000	MTR 60HP 575-3-60 ODP PREM 1800RPM BALDOR EM2547T-5
60	PREM	TEFC	200	60	1800	024-34445-000	MTR 60HP 200/208-3-60 TEFC PREM 1800RPM BALDOR CUSTOM
60	PREM	TEFC	575	60	1800	024-34446-000	MTR 60HP 575-3-60 TEFC PREM 1800RPM BALDOR ECP4314T-5

Continued on next page

FAN MOTORS (CONTINUED)							
HERTZ	EFF	TYPE	VOLT.	HP	NOM RPM	PART NUMBER	DESCRIPTION
60	HIGH	ODP	200	75	1800	024-34447-000	MTR 75HP 200/208-3-60 ODP HIGH 1800RPM BALDOR M2551T-8
60	HIGH	TEFC	200	75	1800	024-34448-000	MTR 75HP 200/208-3-60 TEFC HIGH 1800RPM BALDOR CUSTOM
60	PREM	ODP	575	75	1800	024-34449-000	MTR 75HP 575-3-60 ODP PREM 1800RPM BALDOR 44WGW126
60	PREM	TEFC	200	75	1800	024-34450-000	MTR 75HP 200/208-3-60 TEFC PREM 1800RPM BALDOR CUSTOM
60	PREM	TEFC	575	75	1800	024-34451-000	MTR 75HP 575-3-60 TEFC PREM 1800RPM BALDOR ECP4316T-5
60	HIGH	ODP	200	100	1800	024-34452-000	MTR 100HP 200/208-3-60 ODP HIGH 1800RPM BALDOR M2555T-8
60	HIGH	TEFC	200	100	1800	024-34453-000	MTR 100HP 200/208-3-60 TEFC HIGH 1800RPM BALDOR CUSTOM
60	PREM	ODP	230/460	100	1800	024-34454-000	MTR 100HP 230/460-3-60 ODP PREM 1800RPM BALDOR 16WGW559
60	PREM	ODP	575	100	1800	024-34455-000	MTR 100HP 575-3-60 ODP PREM 1800RPM BALDOR 16WGW614
60	PREM	TEFC	200	100	1800	024-34456-000	MTR 100HP 200/208-3-60 TEFC PREM 1800RPM BALDOR CUSTOM
60	PREM	TEFC	230/460	100	1800	024-34457-000	MTR 100HP 230/460-3-60 TEFC PREM 1800RPM BALDOR CUSTOM
60	PREM	TEFC	575	100	1800	024-34458-000	MTR 100HP 575-3-60 TEFC PREM 1800RPM BALDOR ECP4400T-5
50	HIGH	TEFC	380	1	1500	024-34459-000	MTR 1HP 380-3-50 TEFC HIGH 1500RPM BALDOR M3546T-50
50	HIGH	ODP	380	1	1500	024-34460-000	MTR 1HP 380-3-50 ODP HIGH 1500RPM BALDOR M3116T-50
50	HIGH	ODP	380	1.5	1500	024-34461-000	MTR 1.5HP 380-3-50 ODP HIGH 1500RPM BALDOR M3154T-50
50	HIGH	ODP	380	2	1500	024-34462-000	MTR 2HP 380-3-50 ODP HIGH 1500RPM BALDOR M3157T-50
50	HIGH	TEFC	380	5	1500	024-34463-000	MTR 5HP 380-3-50 TEFC HIGH 1500RPM BALDOR M3615T-50
50	HIGH	TEFC	380	7.5	1500	024-34464-000	MTR 7.5HP 380-3-50 TEFC HIGH 1500RPM BALDOR M3710T-50
50	HIGH	ODP	380	10	1500	024-34466-000	MTR 10HP 380-3-50 ODP HIGH 1500RPM BALDOR M3313T-50
50	HIGH	ODP	380	15	1500	024-34467-000	MTR 15HP 380-3-50 ODP HIGH 1500RPM BALDOR M2513T-50
50	HIGH	ODP	380	20	1500	024-34468-000	MTR 20HP 380-3-50 ODP HIGH 1500RPM BALDOR M2515T-50
50	HIGH	ODP	380	25	1500	024-34469-000	MTR 25HP 380-3-50 ODP HIGH 1500RPM BALDOR 39X214
50	HIGH	ODP	380	30	1500	024-34470-000	MTR 30HP 380-3-50 ODP HIGH 1500RPM BALDOR 40W989
50	HIGH	ODP	380	40	1500	024-34471-000	MTR 40HP 380-3-50 ODP HIGH 1500RPM BALDOR 40W473
50	HIGH	ODP	380	50	1500	024-34472-000	MTR 50HP 380-3-50 ODP HIGH 1500RPM BALDOR 40W565
50	HIGH	ODP	380	60	1500	024-34473-000	MTR 60HP 380-3-50 ODP HIGH 1500RPM BALDOR 42W598
50	HIGH	ODP	380	75	1500	024-34474-000	MTR 75HP 380-3-50 ODP HIGH 1500RPM BALDOR 42W502
50	HIGH	ODP	380	100	1500	024-34475-000	MTR 100HP 380-3-50 ODP HIGH 1500RPM BALDOR 44W096
50	HIGH	TEFC	380	1.5	1500	024-34819-000	MTR 1.5HP 380-3-50 TEFC HIGH 1500RPM BALDOR M3554T-50
50	HIGH	TEFC	380	2	1500	024-34820-000	MTR 2HP 380-3-50 TEFC HIGH 1500RPM BALDOR M3558T-50
50	HIGH	TEFC	380	3	1500	024-34821-000	MTR 3HP 380-3-50 TEFC HIGH 1500RPM BALDOR M3611T-50
50	HIGH	TEFC	380	20	1500	024-34822-000	MTR 20HP 380-3-50 TEFC HIGH 1500RPM BALDOR M2334T-50
50	HIGH	TEFC	380	25	1500	024-34823-000	MTR 25HP 380-3-50 TEFC HIGH 1500RPM BALDOR M4103T-50
50	HIGH	TEFC	380	30	1500	024-34824-000	MTR 30HP 380-3-50 TEFC HIGH 1500RPM BALDOR M4104T-50
50	HIGH	TEFC	380	40	1500	024-34825-000	MTR 40HP 380-3-50 TEFC HIGH 1500RPM BALDOR M4110T-50
50	HIGH	TEFC	380	50	1500	024-34826-000	MTR 50HP 380-3-50 TEFC HIGH 1500RPM BALDOR M4115T-50
50	HIGH	TEFC	380	60	1500	024-34827-000	MTR 60HP 380-3-50 TEFC HIGH 1500RPM BALDOR M4314T-50
50	HIGH	TEFC	380	75	1500	024-34828-000	MTR 75HP 380-3-50 TEFC HIGH 1500RPM BALDOR 14X116
50	HIGH	TEFC	380	100	1500	024-34829-000	MTR 100HP 380-3-50 TEFC HIGH 1500RPM BALDOR 16W740

### MOTOR WIRING PARTS

WIRE CONNECTORS			
PART NUMBER	MOTOR VOLTAGE	HP	QTY
025-39042-001	200/208V	1,2,3	3
	230/240V	1,2,3	4
	460V	1,2,3,5,7.5	6
025-39042-003	200/208V	5	3
	230/240V	5,7.5,10	4
	460V	10,15	6
025-39043-001	200/208V	7.5,10	4
	200/208V	15,20	3
	230/240V	15,20,25	3
	460V	20,25,30,40,50	6
025-39043-002	460V	60,75	6
025-39043-003	460V	100	6
025-39044-001	230/240V	10	3
025-39044-002	200/208V	25,30,40	3
	230/240V	30,40,50	3

FLEXIBLE CABLE SLEEVES			
PART NUMBER	MOTOR VOLTAGE	HP	QTY
025-39049-001	200/208V	7.5,10,15	3
	230/240V	10	3
	230/240V	15	6
	460V	20,25,30,40	3
025-39049-002	200/208V	20	6
	200/208V	25	9
	230/240V	20,25	6
025-39049-003	460V	50	12
	200/208V	30	3
	230/240V	30	9
025-39049-004	230/240V	40	12
	460V	60,75	12
	200/208V	40	9
025-39049-004	230/240V	50	12
	460V	100	12
	200/208V	40	9

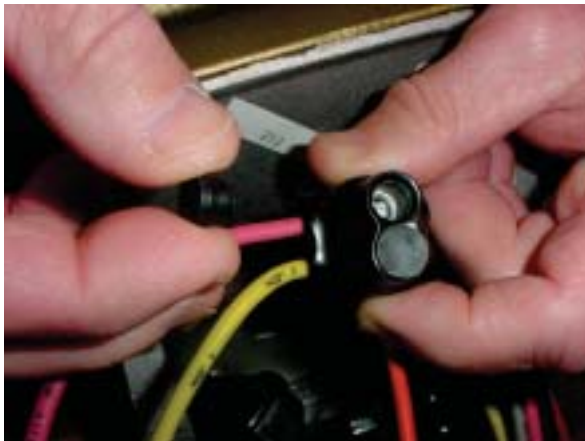

FIG. 6 - ASSEMBLY OF CONNECTORS



FIG. 7 - MOTOR WIRE CONNECTIONS

ADJUSTABLE MOTOR BASES								
Frame Size	Motor HP	Assembly Base P/N	Fan Size/Type	Fan Size/Type	Fan Size/Type	Fan Size/Type	Fan Size/Type	Fan Size/Type
143T	1	386-23937-001	FC7-7	FC9-6	FC10-7	PL121		
145T	2	386-23937-001	FC7-7	FC9-6	FC10-7	PL121		
182T	3	386-23937-001	FC7-7	FC9-6	FC10-7	PL121		
184T	5	386-23937-001	FC7-7	FC9-6	FC10-7	PL121		
182T	3	386-23940-001	FC9-9	FC10-10	FC12-9	PL141	PL161	
184T	5	386-23940-001	FC9-9	FC10-10	FC12-9	PL141	PL161	
143T	1	386-23943-001	FC9-9	FC10-10	FC12-9	PL141	PL161	
145T	2	386-23943-001	FC9-9	FC10-10	FC12-9	PL141	PL161	
213T	7.5	386-23943-001	FC9-9	FC10-10	FC12-9	PL141	PL161	
215T	10	386-23943-001					PL161	
213T	7.5	386-23946-001	AF-FC12-12	FC15-11	AF-FC15-15	FC18-13	AF-FC18-18	BAF122
215T	10	386-23946-001	AF-FC12-12	FC15-11	AF-FC15-15	FC18-13	AF-FC18-18	BAF122
143T	1	386-23949-001	AF-FC12-12	FC15-11	AF-FC15-15			BAF122
145T	2	386-23949-001	AF-FC12-12	FC15-11	AF-FC15-15	FC18-13	AF-FC18-18	BAF122
182T	3	386-23949-001	AF-FC12-12	FC15-11	AF-FC15-15	FC18-13	AF-FC18-18	BAF122
184T	5	386-23949-001	AF-FC12-12	FC15-11	AF-FC15-15	FC18-13	AF-FC18-18	BAF122
254T	15	386-23949-001	AF-FC12-12	FC15-11	AF-FC15-15	FC18-13	AF-FC18-18	BAF122
256T	20	386-23949-001					AF-FC18-18	
213T	7.5	386-23952-001	FC20-15	AF-FC20-20	BAF182	BAF200	BAF222	BAF245
215T	10	386-23952-001	FC20-15	AF-FC20-20	BAF182	BAF200	BAF222	BAF245
284T	25	386-23952-001	FC20-15	AF-FC20-20	BAF182	BAF200	BAF222	BAF245
286T	30	386-23952-001		AF-FC20-20		BAF200	BAF222	BAF245
143T	1	386-23956-001						
145T	2	386-23956-001	FC20-15	AF-FC20-20	BAF182	BAF200	BAF222	BAF245
182T	3	386-23956-001	FC20-15	AF-FC20-20	BAF182	BAF200	BAF222	BAF245
184T	5	386-23956-001	FC20-15	AF-FC20-20	BAF182	BAF200	BAF222	BAF245
254T	15	386-23956-001	FC20-15	AF-FC20-20	BAF182	BAF200	BAF222	BAF245
256T	20	386-23956-001	FC20-15	AF-FC20-20	BAF182	BAF200	BAF222	BAF245
324T	40	386-23956-001					BAF222	BAF245
213T	7.5	386-23960-001	AF-FC22-22	AF-FC25-25	AF-FC28-28	AF-FC32-32	AF-FC36-36	AF-FC40-40
215T	10	386-23960-001	AF-FC22-22	AF-FC25-25	AF-FC28-28	AF-FC32-32	AF-FC36-36	AF-FC40-40
284T	25	386-23960-001	AF-FC22-22	AF-FC25-25	AF-FC28-28	AF-FC32-32	AF-FC36-36	AF-FC40-40
286T	30	386-23960-001	AF-FC22-22	AF-FC25-25	AF-FC28-28	AF-FC32-32	AF-FC36-36	AF-FC40-40
364T	60	386-23960-001			AF-FC28-28	AF-FC32-32	AF-FC36-36	AF-FC40-40
365T	75	386-23960-001				AF-FC32-32	AF-FC36-36	AF-FC40-40

Continued on next page

ADJUSTABLE MOTOR BASES (CONTINUED)								
Frame Size	Motor HP	Assembly Base P/N	Fan Size/Type	Fan Size/Type	Fan Size/Type	Fan Size/Type	Fan Size/Type	Fan Size/Type
143T	1	386-23965-001			AF-FC28-28	AF-FC32-32		
145T	2	386-23965-001			AF-FC28-28	AF-FC32-32		
182T	3	386-23965-001	AF-FC22-22	AF-FC25-25	AF-FC28-28	AF-FC32-32		
184T	5	386-23965-001	AF-FC22-22	AF-FC25-25	AF-FC28-28	AF-FC32-32	AF-FC36-36	AF-FC40-40
254T	15	386-23965-001	AF-FC22-22	AF-FC25-25	AF-FC28-28	AF-FC32-32	AF-FC36-36	AF-FC40-40
256T	20	386-23965-001	AF-FC22-22	AF-FC25-25	AF-FC28-28	AF-FC32-32	AF-FC36-36	AF-FC40-40
324T	40	386-23965-001	AF-FC22-22	AF-FC25-25	AF-FC28-28	AF-FC32-32	AF-FC36-36	AF-FC40-40
326T	50	386-23965-001	AF-FC22-22	AF-FC25-25	AF-FC28-28	AF-FC32-32	AF-FC36-36	AF-FC40-40
404T	100	386-23965-001						AF-FC40-40
405T	125	386-23965-001						
213T	7.5	386-23946-001	BAF135	BAF150	BAF165	PL181	PL201	
215T	10	386-23946-001	BAF135	BAF150	BAF165	PL181	PL201	
143T	1	386-23949-001	BAF135	BAF150	BAF165	PL181		
145T	2	386-23949-001	BAF135	BAF150	BAF165	PL181	PL201	
182T	3	386-23949-001	BAF135	BAF150	BAF165	PL181	PL201	
184T	5	386-23949-001	BAF135	BAF150	BAF165	PL181	PL201	
254T	15	386-23949-001	BAF135	BAF150	BAF165	PL181	PL201	
256T	20	386-23949-001		BAF150	BAF165	PL181	PL201	
213T	7.5	386-23952-001	BAF270	PL221	PL251	PL281		
215T	10	386-23952-001	BAF270	PL221	PL251	PL281		
284T	25	386-23952-001	BAF270	PL221	PL251	PL281		
286T	30	386-23952-001	BAF270		PL251	PL281		
143T	1	386-23956-001			PL251	PL281		
145T	2	386-23956-001		PL221	PL251	PL281		
182T	3	386-23956-001	BAF270	PL221	PL251	PL281		
184T	5	386-23956-001	BAF270	PL221	PL251	PL281		
254T	15	386-23956-001	BAF270	PL221	PL251	PL281		
256T	20	386-23956-001	BAF270	PL221	PL251	PL281		
324T	40	386-23956-001	BAF270		PL251	PL281		
326T	50	386-23956-001	BAF270			PL281		
213T	7.5	386-23960-001	BAF300	BAF330	BAF365	BAF402	BAF445	PL321
215T	10	386-23960-001	BAF300	BAF330	BAF365	BAF402	BAF445	PL321
284T	25	386-23960-001	BAF300	BAF330	BAF365	BAF402	BAF445	PL321
286T	30	386-23960-001	BAF300	BAF330	BAF365	BAF402	BAF445	PL321
364T	60	386-23960-001	BAF300	BAF330	BAF365	BAF402	BAF445	PL321
365T	75	386-23960-001		BAF330	BAF365	BAF402	BAF445	

Continued on next page

**ADJUSTABLE MOTOR BASES (CONTINUED)**

Frame Size	Motor HP	Assembly Base P/N	Fan Size/Type	Fan Size/Type	Fan Size/Type	Fan Size/Type	Fan Size/Type	Fan Size/Type
143T	1	386-23965-001						
145T	2	386-23965-001						PL321
182T	3	386-23965-001	BAF300	BAF330	BAF365	BAF402		PL321
184T	5	386-23965-001	BAF300	BAF330	BAF365	BAF402	BAF445	PL321
254T	15	386-23965-001	BAF300	BAF330	BAF365	BAF402	BAF445	PL321
256T	20	386-23965-001	BAF300	BAF330	BAF365	BAF402	BAF445	PL321
324T	40	386-23965-001	BAF300	BAF330	BAF365	BAF402	BAF445	PL321
326T	50	386-23965-001	BAF300	BAF330	BAF365	BAF402	BAF445	PL321
404T	100	386-23965-001			BAF365	BAF402	BAF445	
405T	125	386-23965-001						
213T	7.5	386-23960-001	PL351					
215T	10	386-23960-001	PL351	PL391	PL441	PL491	PL551	
284T	25	386-23960-001	PL351	PL391	PL441	PL491	PL551	
286T	30	386-23960-001	PL351	PL391	PL441	PL491	PL551	
364T	60	386-23960-001	PL351	PL391	PL441	PL491	PL551	
365T	75	386-23960-001	PL351	PL391	PL441	PL491	PL551	
143T	1	386-23965-001	PL351	PL391				
145T	2	386-23965-001	PL351	PL391	PL441			
182T	3	386-23965-001	PL351	PL391	PL441			
184T	5	386-23965-001	PL351	PL391	PL441	PL491	PL551	
254T	15	386-23965-001	PL351	PL391	PL441	PL491	PL551	
256T	20	386-23965-001	PL351	PL391	PL441	PL491	PL551	
324T	40	386-23965-001	PL351	PL391	PL441	PL491	PL551	
326T	50	386-23965-001	PL351	PL391	PL441	PL491	PL551	
404T	100	386-23965-001		PL391	PL441	PL491	PL551	
405T	125	386-23965-001						

See Fig. 9 "Securing Fans and Motors" for proper hardware.

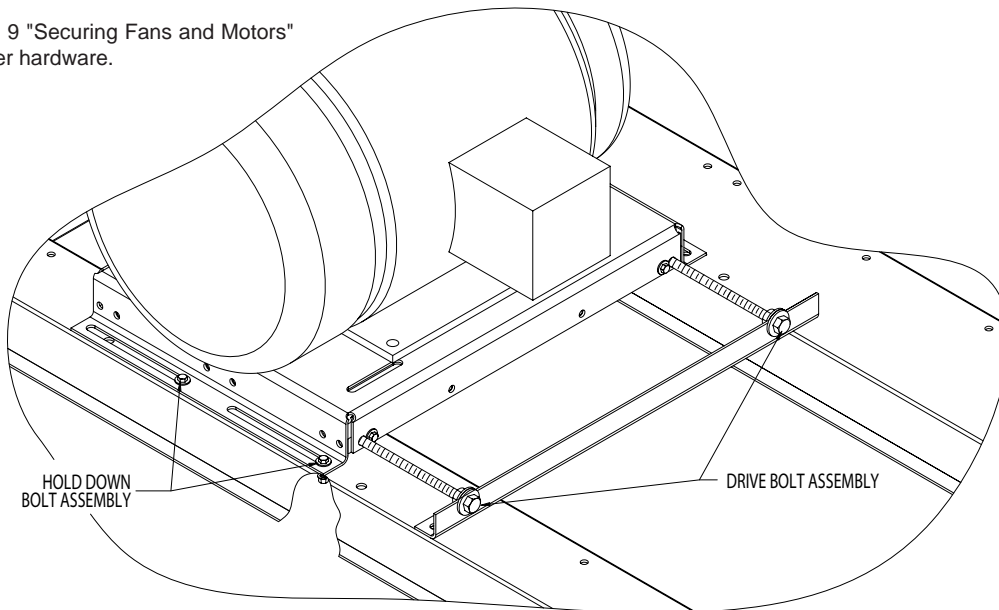
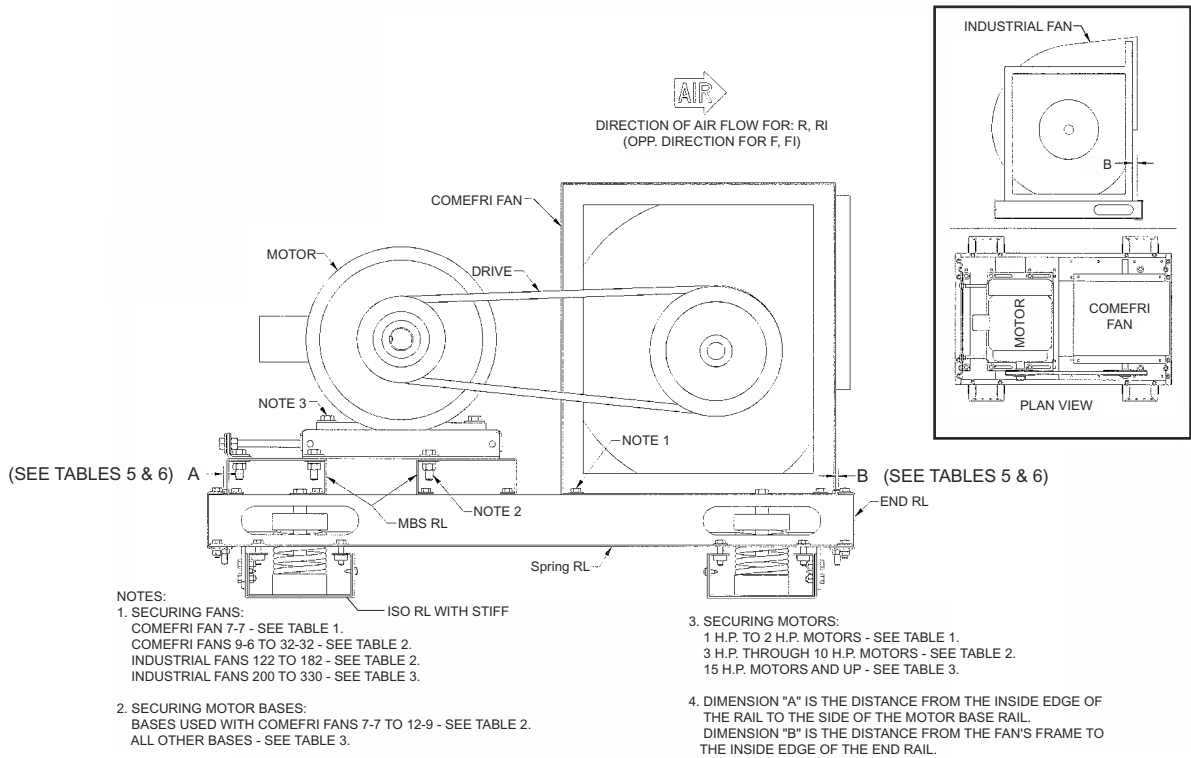
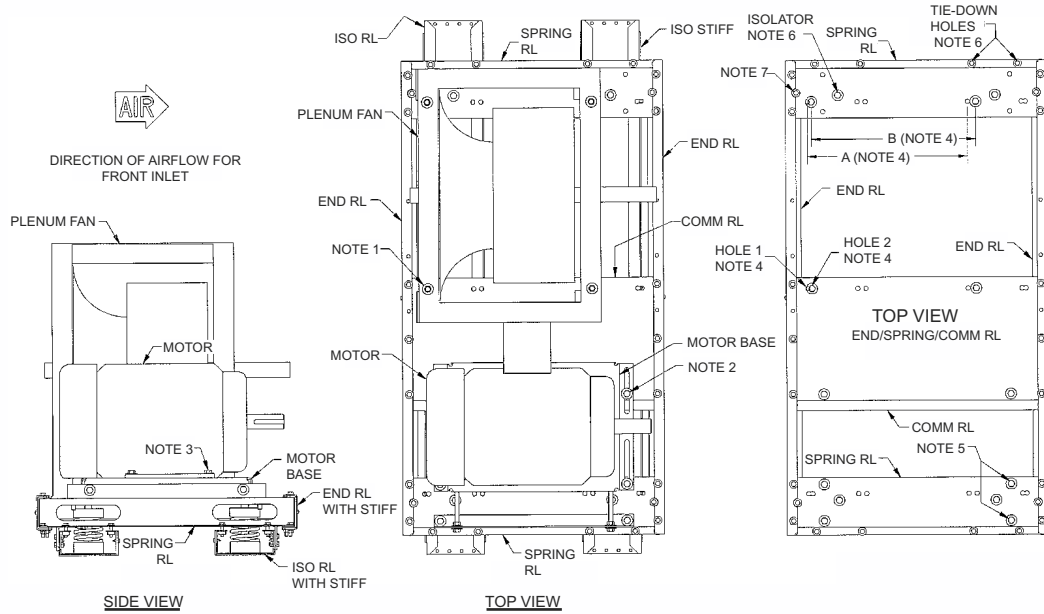

FIG. 8 - ADJUSTABLE MOTOR BASE

LDO9693



F/R COMEFRI/INDUSTRIAL MTR BH FAN SKID ASSY



PLENUM MTR BS FAN SKID ASSY

FIG. 9 - SECURING FANS AND MOTORS

LDO9703

**FANS AND MOTORS, SECURING**

<b>TABLE 1</b>		
<b>P/N</b>	<b>DESCRIPTION</b>	<b>QTY.</b>
021-03749-000	SCR MACH RD PH 1/4-20UNC-2A X 1-1/4 LG STL ZINC PLTD.	1
021-01248-000	WASHER PLAIN 5/16 ID X 3/4 OD X 0.065 NOM THK : STEEL	2
021-16151-000	LOCK WASHER SPG HELICAL 1/4, STEEL	1
021-17718-000	NUT HEX 1/4 - 20 UNC - 2B	1
<b>TABLE 2</b>		
<b>P/N</b>	<b>DESCRIPTION</b>	<b>QTY.</b>
021-01499-000	SCREW, CAP HEX 3/8 - 16 UNC - 2A X 1.5, ZINC PLATED	1
021-01267-000	WASH FLT 7/16 ID X 1 OD X 0.083 THK STL ZINC PLTD.	2
021-01155-000	WASH, LK TH INT 3/8 STD C-76	1
021-19307-000	NUT HEX LK 3/8-16 ZINC PLATED	1
<b>TABLE 3</b>		
<b>P/N</b>	<b>DESCRIPTION</b>	<b>QTY.</b>
021-17728-000	SCR HEX 1/2-13UNC-2A X 1.75" SAE J429	1
021-05146-000	WASH, FLT 9/16 ID X 1-3/8 OD .109 THK STL ZINC PLATED	2
021-01163-000	WASH, LK TH INT 1/2 HVY STL ZINC PLTD., STD. C-76	1
021-02860-000	NUT, HEX 1/2-13 HVY 7/8 STL ZINC PLTD., STD. C-85	1
<b>TABLE 4</b>		
<b>P/N</b>	<b>DESCRIPTION</b>	<b>QTY.</b>
021-13830-000	SCR HEX CAP 3/4-10 X 2-1/2, STL ZINC PLTD	1
021-15802-000	WASH FLT 13/16 ID X 1-3/4 OD X 0.134 THK STL ZINC	2
021-19571-000	WASH LK TH INT 3/4 STL ZINC PLTD., STD. C-76	1
021-12656-000	NUT HEX 3/4-10 HVY STL ZINC CTD ASA B18	1

<b>TABLE 5</b>		
<b>COMEFRI FAN</b>	<b>A</b>	<b>B</b>
7-7	0.15	0.3
9-6	0.08	0.19
9-9	0.3	0.19
10-7	0.16	0.19
10-10	0.13	0.19
12-9	0.32	0.19
12-12	0.23	0.19
15-11	0.13	0.19
15-15	0.15	0.19
18-13	0.26	0.19
18-18	0.28	0.19
20-15	1.05	1.09
20-20	1.05	1.09
22-22	1.93	1.01
25-25	1.97	1.32
28-28	0.59	1.69
32-32	2.74	2.07

<b>TABLE 6</b>		
<b>INDUSTRIAL FAN</b>	<b>A</b>	<b>B</b>
122	0.23	0.19
135	0.14	0.19
150	0.17	0.2
165	0.2	0.19
182	1.04	0.19
200	1.08	0.19
222	2.17	0.45
245	1.97	1.13
270	1.89	1.82
300	0.77	1.69
330	0.73	2.63



## ISOLATORS

TOP CAP ASSY P/N	BOTTOM CUP P/N	OUTER SPRING DESCRIPTION	OUTER SPRING COLOR	OUTER SPRING P/N	INNER SPRING DESC.	INNER SPRING COLOR	INNER SPRING P/N	RATED LOAD *	SPRING K (LBS/IN)	RATED DEFL	NOM DEFL	MIN LOAD RANGE	MAX LOAD RANGE	ASSY WHT (LBS.)
029-22024-002	029-24219-002	ISOLATOR, 1" OUTER SPRING, ALCY-90	PINK	029-22025-002	NA	NA	NA	78	60	1.3	1	1	74	3.00
029-22024-002	029-24219-002	ISOLATOR, 1" OUTER SPRING, ALCY-92	BROWN	029-22025-007	NA	NA	NA	154	96	1.6	1	75	146	3.00
029-22024-002	029-24219-002	ISOLATOR, 1" OUTER SPRING, ALCY-93	ORANGE	029-22025-052	NA	NA	NA	225	173	1.3	1	147	213	3.00
029-22024-002	029-24219-002	ISOLATOR, 1" OUTER SPRING, ALCY-94	GREEN	029-22025-011	NA	NA	NA	325	270	1.2	1	215	308	3.00
029-22024-002	029-24219-002	ISOLATOR, 1" OUTER SPRING, ALCY-95	RED	029-22025-013	NA	NA	NA	450	368	1.2	1	310	427	3.00
029-22024-002	029-24219-002	ISOLATOR, 1" OUTER SPRING, ALCY-96	BLACK	029-22025-051	NA	NA	NA	615	513	1.2	1	429	570	3.00
029-22024-002	029-24219-002	ISOLATOR, 1" OUTER SPRING, ALCY-97	WHITE	029-22025-038	NA	NA	NA	750	707	1.1	1	571	712	3.00
029-22024-002	029-24219-002	ISOLATOR, 1" OUTER SPRING, ALCY-99	BLUE	029-22025-039	NA	NA	NA	1100	1200	0.9	1	714	1080	3.00
029-22024-002	029-24219-002	ISOLATOR, 2" OUTER SPRING, ALCY-81	BLUE	029-22025-047	NA	NA	NA	20	10	2	2	1	19	3.00
029-22024-002	029-24219-002	ISOLATOR, 2" OUTER SPRING, ALCY-82	ORANGE	029-22025-048	NA	NA	NA	26	13	2	2	20	24	3.00
029-22024-002	029-24219-002	ISOLATOR, 2" OUTER SPRING, ALCY-83	PURPLE	029-22025-049	NA	NA	NA	36	18	2	2	26	34	3.00
029-22024-002	029-24219-002	ISOLATOR, 2" OUTER SPRING, ALCY-84	YELLOW	029-22025-022	NA	NA	NA	52	26	2	2	35	49	3.00
029-22024-002	029-24219-002	ISOLATOR, 2" OUTER SPRING, ALCY-85	GRAY	029-22025-023	NA	NA	NA	65	32.5	2	2	50	61	3.00
029-22024-002	029-24219-002	ISOLATOR, 2" OUTER SPRING, ALCY-86	RED	029-22025-024	NA	NA	NA	84	42	2	2	63	79	3.00
029-22024-002	029-24219-002	ISOLATOR, 2" OUTER SPRING, ALCY-87	GREEN	029-22025-026	NA	NA	NA	114	57	2	2	81	108	3.00
029-22024-004	029-24219-004	ISOLATOR, 2" OUTER SPRING, ALCY-203	RED	029-22025-028	NA	NA	NA	175	88	2	2	109	166	3.00
029-22024-004	029-24219-004	ISOLATOR, 2" OUTER SPRING, ALCY-204	GREEN	029-22025-053	NA	NA	NA	250	125	2	2	167	237	3.00
029-22024-004	029-24219-004	ISOLATOR, 2" OUTER SPRING, ALCY-205	GRAY	029-22025-033	NA	NA	NA	330	165	2	2	239	313	3.00
029-22024-004	029-24219-004	ISOLATOR, 2" OUTER SPRING, ALCY-206	YELLOW	029-22025-050	NA	NA	NA	450	225	2	2	315	427	3.00
029-22024-004	029-24219-004	ISOLATOR, 2" OUTER SPRING, ALCY-207	ORANGE	029-22025-054	NA	NA	NA	600	300	2	2	429	570	6.00
029-22024-004	029-24219-004	ISOLATOR, 2" OUTER SPRING, ALCY-208	WHITE	029-22025-055	NA	NA	NA	750	417	1.8	2	571	713	6.00
029-22024-003	029-24219-003	ISOLATOR, 1" OUTER SPRING, AWCY-200	BLUE	029-22025-004	NA	NA	NA	100	100	1	1	1	95	6.00
029-22024-003	029-24219-003	ISOLATOR, 1" OUTER SPRING, AWCY-219	BLUE	029-22025-004	ISOLATOR, 1" INNER SPRING	PINK	029-22025-056	210	162	1.3	1	96	133	6.00
029-22024-003	029-24219-003	ISOLATOR, 1" OUTER SPRING, AWCY-221	BLUE	029-22025-004	ISOLATOR, 1" INNER SPRING	BLACK	029-22025-008	180	187	0.9	1	134	171	6.00
029-22024-003	029-24219-003	ISOLATOR, 1" OUTER SPRING, AWCY-222	BLUE	029-22025-004	ISOLATOR, 1" INNER SPRING	BLUE	029-22025-010	295	233	1.3	1	172	228	6.00
029-22024-003	029-24219-003	ISOLATOR, 1" OUTER SPRING, AWCY-400	BLACK	029-22025-012	NA	NA	NA	330	303	1.1	1	229	313	6.00
029-22024-003	029-24219-003	ISOLATOR, 1" OUTER SPRING, AWCY-419	BLACK	029-22025-012	ISOLATOR, 1" INNER SPRING	PINK	029-22025-056	485	366	1.3	1	315	414	6.00
029-22024-003	029-24219-003	ISOLATOR, 1" OUTER SPRING, AWCY-423	BLACK	029-22025-012	ISOLATOR, 1" INNER SPRING	YELLOW	029-22025-014	625	482	1.3	1	415	537	6.00
029-22024-003	029-24219-003	ISOLATOR, 1" OUTER SPRING, AWCY-600	RED	029-22025-016	NA	NA	NA	620	620	1	1	538	640	6.00
029-22024-003	029-24219-003	ISOLATOR, 1" OUTER SPRING, AWCY-624	RED	029-22025-015	ISOLATOR, 1" INNER SPRING	BROWN	029-22025-017	880	884	1	1	641	890	6.00
029-22024-003	029-24219-003	ISOLATOR, 1" OUTER SPRING, AWCY-1023	GREEN	029-22025-019	ISOLATOR, 1" INNER SPRING	YELLOW	029-22025-014	1285	1130	1.1	1	891	1220	6.00
029-22024-003	029-24219-003	ISOLATOR, 1" OUTER SPRING, AWCY-1024	GREEN	029-22025-019	ISOLATOR, 1" INNER SPRING	BROWN	029-22025-017	1385	1216	1.1	1	1222	1315	6.00
029-22024-003	029-24219-003	ISOLATOR, 1" OUTER SPRING, AWCY-1621	GRAY	029-22025-040	ISOLATOR, 1" INNER SPRING	BLACK	029-22025-008	1687	1688	1	1	1317	1602	6.00
029-22024-003	029-24219-003	ISOLATOR, 1" OUTER SPRING, AWCY-1622	GRAY	029-22025-040	ISOLATOR, 1" INNER SPRING	BLUE	029-22025-010	1770	1733	1	1	1604	1681	6.00
029-22024-003	029-24219-003	ISOLATOR, 1" OUTER SPRING, AWCY-1626	GRAY	029-22025-040	ISOLATOR, 1" INNER SPRING	PURPLE	029-22025-043	2200	2113	1	1	1683	2090	6.00
029-22024-003	029-24219-003	ISOLATOR, 1" OUTER SPRING, AWCY-1627	GRAY	029-22025-040	ISOLATOR, 1" INNER SPRING	ORANGE	029-22025-044	2350	2307	1	1	2091	2232	6.00
029-22024-003	029-24219-003	ISOLATOR, 1" OUTER SPRING, AWCY-1631	GRAY	029-22025-040	ISOLATOR, 1" INNER SPRING	GRAY	029-22025-045	2700	2647	1	1	2234	2565	6.00
029-22024-003	029-24219-003	ISOLATOR, 1" OUTER SPRING, AWCY-1632	GRAY	029-22025-040	ISOLATOR, 1" INNER SPRING	WHITE	029-22025-046	2900	3411	0.85	1	2566	2880	6.00

\* To obtain Rated Load, Inner Spring must be ordered in addition to Assembly.

Continued on next page

ISOLATORS (CONT.)

TOP CAP ASSY P/N	BOTTOM CUP P/N	OUTER SPRING DESCRIPTION	OUTER SPRING COLOR	OUTER SPRING P/N	INNER SPRING DESC.	INNER SPRING COLOR	INNER SPRING P/N	RATED LOAD *	SPRING K (LBS/IN)	RATED DEFL	NOM DEFL	MIN LOAD RANGE	MAX LOAD RANGE	ASSY WHT (LBS.)
029-22024-003	029-24219-003	ISOLATOR, 2" OUTER SPRING, AWCY-401	BLUE	029-22025-025	NA	NA	NA	100	50	2	2	1	95	6.00
029-22024-003	029-24219-003	ISOLATOR, 2" OUTER SPRING, AWCY-402	YELLOW	029-22025-027	NA	NA	NA	140	70	2	2	96	133	6.00
029-22024-003	029-24219-003	ISOLATOR, 2" OUTER SPRING, AWCY-403	BLACK	029-22025-029	NA	NA	NA	180	90	2	2	134	171	6.00
029-22024-003	029-24219-003	ISOLATOR, 2" OUTER SPRING, AWCY-404	PURPLE	029-22025-031	NA	NA	NA	240	120	2	2	172	228	6.00
029-22024-003	029-24219-003	ISOLATOR, 2" OUTER SPRING, AWCY-405	BROWN	029-22025-032	NA	NA	NA	330	165	2	2	229	313	6.00
029-22024-003	029-24219-003	ISOLATOR, 2" OUTER SPRING, AWCY-406	RED	029-22025-034	NA	NA	NA	460	230	2	2	315	437	6.00
029-22024-003	029-24219-003	ISOLATOR, 2" OUTER SPRING, AWCY-407	RED	029-22025-034	ISOLATOR, 2" INNER SPRING	NA	029-22025-035	610	305	2	2	438	579	6.00
029-22024-003	029-24219-003	ISOLATOR, 2" OUTER SPRING, AWCY-408	RED	029-22025-034	ISOLATOR, 2" INNER SPRING	NA	029-22025-036	880	440	2	2	581	836	6.00
029-22024-003	029-24219-003	ISOLATOR, 2" OUTER SPRING, AWCY-409	RED	029-22025-034	ISOLATOR, 2" INNER SPRING	NA	029-22025-037	1210	605	2	2	837	1190	6.00

\* To obtain Rated Load, Inner Spring must be ordered in addition to Assembly.

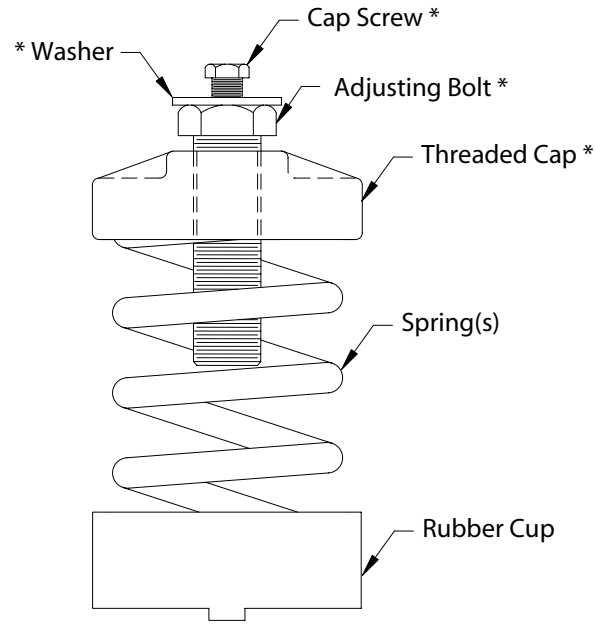

\* Top Cap Assembly

LDO9637-2

FIG. 10 - TYPICAL, ISOLATOR

<b>SHELL COMPONENTS</b>		
<b>REF.</b>	<b>PART NUMBER</b>	<b>DESCRIPTION</b>
1		
2	386-11022-001	Corner Connector, Top & Bottom, with shroud
3	021-19750-000	Screw, BH, Hex Socket
4	086-02026-000	Splice Plate, Raceway, No Lifting
5	029-21340-000	Lifting Lug, 6" Baserail
5	029-21365-000	Lifting Lug, 8" & 10" Baserail
6	029-22044-000	Insert, Raceway Bottom, Shipping Split
7	029-22043-000	Insert, Raceway Top, Shipping Split
8	029-22048-000	Insert, Raceway Bottom, Splice
9	029-22039-000	Lifting Lug, Raceway
10	086-02027-001	3" Baserail Splice Angle, Non Lifting
10	086-02027-002	6" Baserail Splice Angle, Non Lifting
10	086-02027-003	8" & 10" Baserail Splice Angle, Non Lifting
11	021-17728-000	Bolt, 1/2"-13
12	021-01163-000	Lockwasher, 1/2"
13	021-02860-000	Nut, 1/2"-13
14	021-08388-000	Bolt, 1/2"-13
15	029-22070-000	Lug, Lifting, Corner, XT, .164 Thk, galv.
16	086-01923-001	Raceway Positioning Angle, No Lifting (3" Base Rail or No Base Rail)
17	021-01155-000	Washer, Lock, Int, 3/8
18	021-19305-016	Screw, 3/8"-16
19	021-19307-000	Hex Nut, Lock, 3/8"-16
20	021-01481-000	Bolt, 3/8"-16
21	021-19586-000	Nut, Hex 3/8-16, Zinc Plated
22	029-22047-000	Bracket, Tie Down
23	021-17722-000	Screw, Pan Head, 1/4" x 3/4"
24	028-11778-000	Foam Tape
25	021-19570-000	Bolt, 3/8" x 3/4"

<b>SPLICE &amp; SPLIT BASERAIL KITS</b>					
<b>KIT PART NUMBER</b>	<b>DESCRIPTION</b>	<b>* ITEM</b>	<b>PART NUMBER</b>	<b>DESCRIPTION</b>	<b>QTY.</b>
386-17216-008	<b>Split/splice Kit</b> Baserail 6" Only With Lifting	12	021-01163-000	Wash, Lk Th Int 1/2 Hvy Stl Zinc Pltd., Std. C-76	12
		13	021-02860-000	Nut, Hex 1/2-13 Hvy 7/8 Stl Zinc Pltd., Std. C-85	12
		11	021-17728-000	Scr Hex 1/2-13unc-2a X 1.75" Sae J429	12
		5	029-21340-000	Lug,lifting,baserail, For 6" Baserail Only	4
386-17216-009	<b>Split/splice Kit</b> Baserail 8" & 10" Only With Lifting	12	021-01163-000	Wash, Lk Th Int 1/2 Hvy Stl Zinc Pltd., Std. C-76	16
		13	021-02860-000	Nut, Hex 1/2-13 Hvy 7/8 Stl Zinc Pltd., Std. C-85	16
		11	021-17728-000	Scr Hex 1/2-13unc-2a X 1.75" Sae J429	16
		5	029-21365-000	Lug,lifting,baserail, For 8" & 10" Baserail	4
386-17216-010	<b>Split/splice Kit</b> Baserail 3" Only Without Lifting	12	021-01163-000	Wash, Lk Th Int 1/2 Hvy Stl Zinc Pltd., Std. C-76	12
		13	021-02860-000	Nut, Hex 1/2-13 Hvy 7/8 Stl Zinc Pltd., Std. C-85	12
		11	021-17728-000	Scr Hex 1/2-13unc-2a X 1.75" Sae J429	12
		10	086-02027-001	Splice Angle 3" - Baseraills Splice Piece	4
386-17216-011	<b>Splice Kit</b> Baserail 6" Only Without Lifting	12	021-01163-000	Wash, Lk Th Int 1/2 Hvy Stl Zinc Pltd., Std. C-76	16
		13	021-02860-000	Nut, Hex 1/2-13 Hvy 7/8 Stl Zinc Pltd., Std. C-85	16
		11	021-17728-000	Scr Hex 1/2-13unc-2a X 1.75" Sae J429	16
		10	086-02027-002	Splice Angle 6" - Baseraills Splice Piece	4
386-17216-012	<b>Splice Kit</b> Baserail 8 & 10" Only Without Lifting	12	021-01163-000	Wash, Lk Th Int 1/2 Hvy Stl Zinc Pltd., Std. C-76	16
		13	021-02860-000	Nut, Hex 1/2-13 Hvy 7/8 Stl Zinc Pltd., Std. C-85	16
		11	021-17728-000	Scr Hex 1/2-13unc-2a X 1.75" Sae J429	16
		10	086-02027-003	Splice Angle 8" - Baseraills Splice Piece	4

\* See Shell Components Table

SPLICE & SPLIT RACEWAY KITS					
KIT PART NUMBER	DESCRIPTION	* ITEM	PART NUMBER	DESCRIPTION	QTY.
386-17216-001	<b>End Corners Kit</b> XTI No Baserail XTI W/ Baserail XTO W/ Baserail	3	021-19570-000	Screw, Hex Socket Button Head, 3/8 -16 X 3/4, stl Zinc Pltd, grade 5	32
		N/A	021-19568-000	Steel Finishing Plug To Fit 1-1/2" Hole, (Not Shown)	8
		2	386-11022-001	Corner Connector, Top & Bottom, with shroud	4
386-17216-002	<b>Split Kit</b> W/ Lifting XTO & XTI	9	029-22039-000	Lifting Lug	4
		6	029-22044-000	Insert, Raceway Bottom, Shipping Split	4
		17	021-01155-000	Wash Lk Th Int 3/8 Std C-76	20
		3	021-19570-000	Screw, Hex Socket Button Head, 3/8 -16 X 3/4, stl Zinc Pltd, grade 5	20
		7	029-22043-000	Insert, Raceway	2
386-17216-003	<b>Splice Kit</b> Top XTO & XTI	N/A	021-01155-000	Wash Lk Th Int 3/8 Std C-76, (Not Shown)	8
		3	021-19570-000	Screw, Hex Socket Button Head, 3/8 -16 X 3/4, stl Zinc Pltd, grade 5	8
		7	029-22043-000	Insert, Raceway	2
386-17216-004	<b>Splice Kit</b> Bottom W/ Lifting XTO & XTI	9	029-22039-000	Lifting Lug	4
		8	029-22048-000	Insert, Raceway Splice	2
		17	021-01155-000	Wash Lk Th Int 3/8 Std C-76	12
		3	021-19570-000	Screw, Hex Socket Button Head, 3/8 -16 X 3/4, stl Zinc Pltd, grade 5	12
386-17216-005	<b>End Corners Kit</b> XTO No Baserail	3	021-19570-000	Screw, Hex Socket Button Head, 3/8 -16 X 3/4, stl Zinc Pltd, grade 5	32
		17	021-19568-000	Steel Finishing Plug To Fit 1-1/2" Hole	8
		2	386-11022-001	Corner Connector, Top & Bottom, with shroud	4
		15	029-22070-000	Lug, lifting, corner, xt, .164_thk, g90_glv	2
386-17216-006	<b>Split Kit</b> w/o Lifting XTO & XTI	6	029-22044-000	Insert, Raceway Bottom, Shipping Split	4
		16	086-01923-001	Raceway Positioning Angle	4
		17	021-01155-000	Wash Lk Th Int 3/8 Std C-76	20
		18	021-19305-016	Screw, Cap Hex 3/8 - 16 Unc - 2a X 1.0, Zinc Plated Grade 5	20
		7	029-22043-000	Insert, Raceway	2
386-17216-007	<b>Splice Kit</b> Bottom w/o Lifting XTO & XTI	8	029-22048-000	Insert, Raceway Splice	2
		17	021-01155-000	Wash Lk Th Int 3/8 Std C-76	12
		3	021-19570-000	Screw, Hex Socket Button Head, 3/8 -16 X 3/4, stl Zinc Pltd, grade 5	12
		4	086-02026-000	Splice Plate - Rcway - No Lifting.	2

\* See Shell Components Table

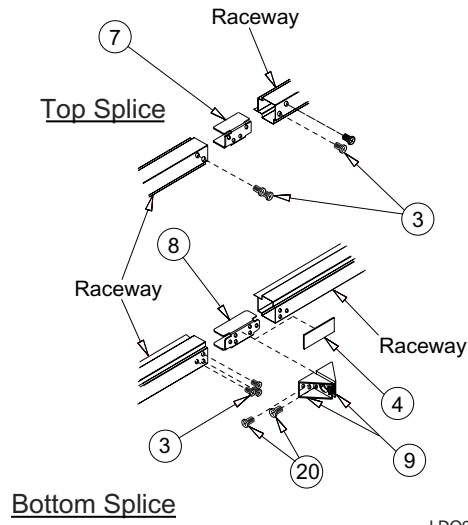

LDO9704

### Splice Assembly

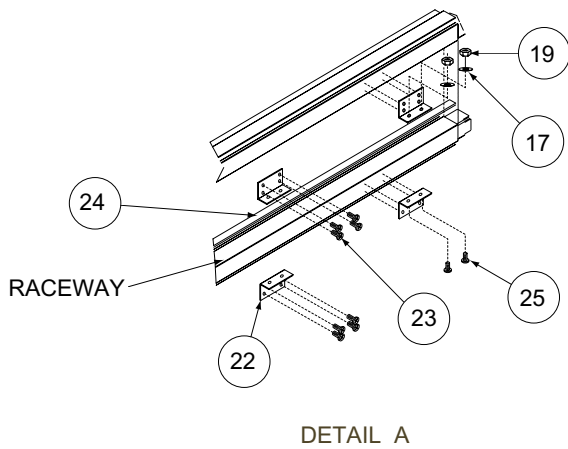

DETAIL A

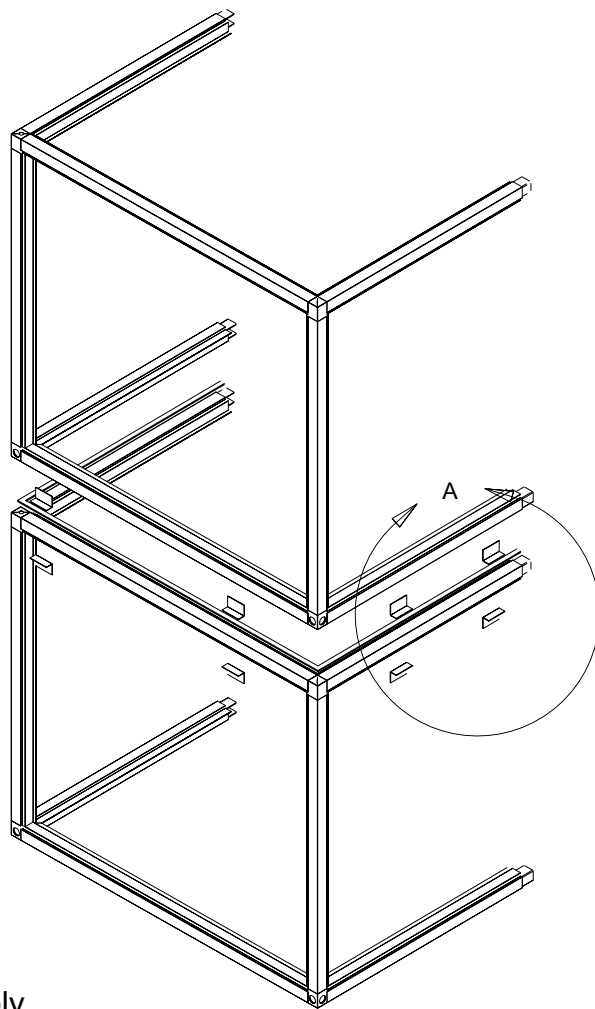

LDO9695

### Stacking Assembly

FIG. 11 - SPLICE & STACKING ASSEMBLIES

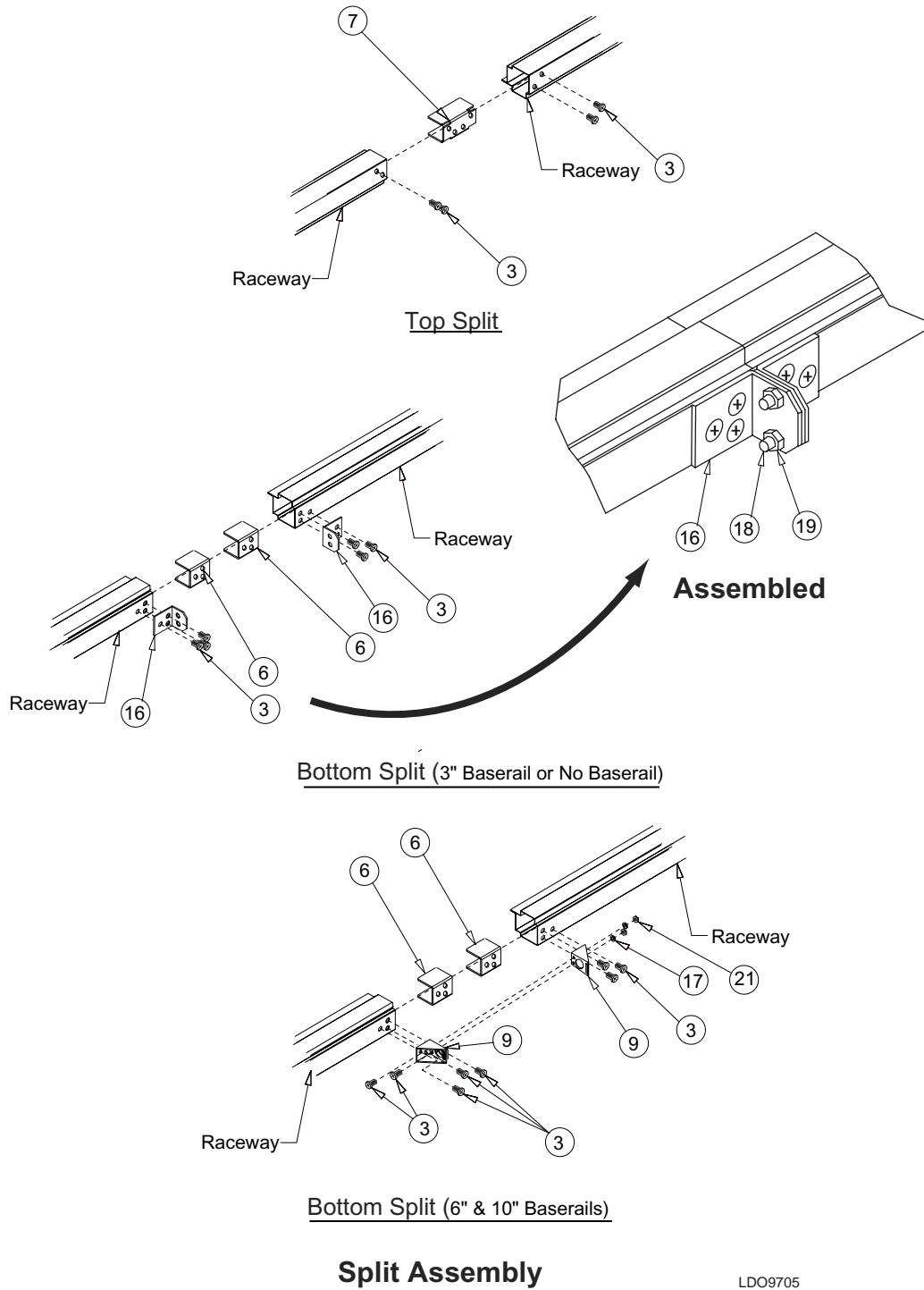
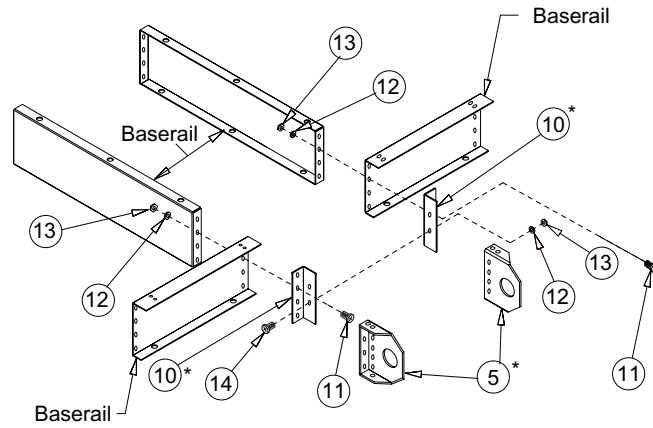

FIG. 12 - SPLIT ASSEMBLY



### Baserail Assembly

\* Use Ref. 10 when no lifting required. Use Ref. 5 when lifting required.  
 Lifting lugs (5) shown in a splice configuration. When used on shipping splits they are rotated 180 deg.

LDO9706

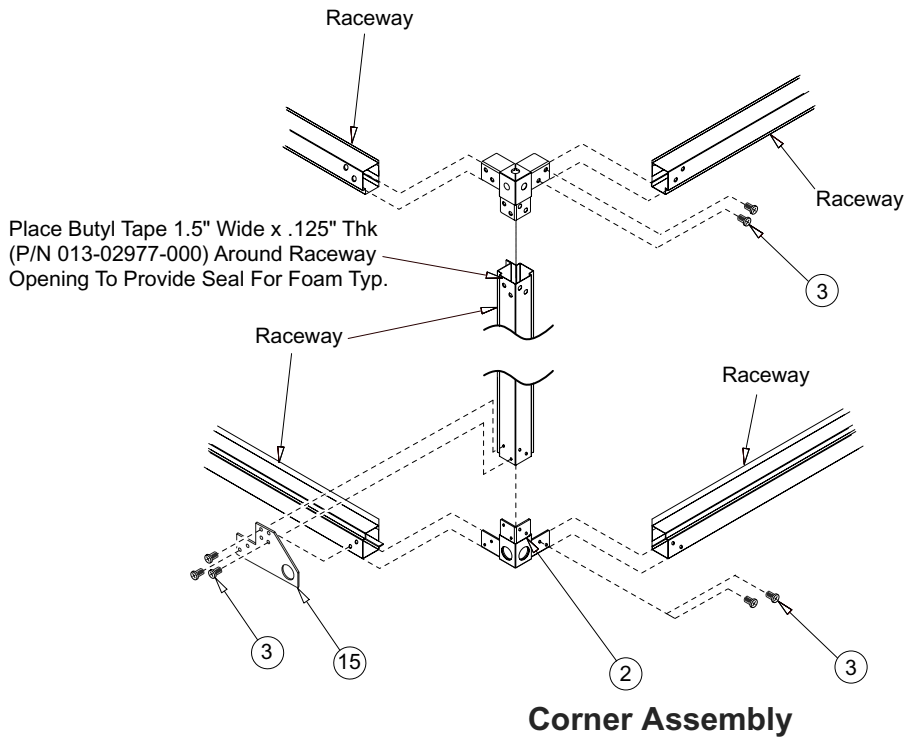

### Corner Assembly

LDO9707

FIG. 13 - BASERAIL & CORNER ASSEMBLIES



<b>WIREWAY ACCESS PLATES</b>			
<b>SINGLE POINT POWER MOTOR CUTOUTS, 4" WIREWAYS ONLY.</b>			
<b>PART NUMBER</b>	<b>DESCRIPTION</b>	<b>MOTOR VOLTAGE</b>	<b>HP</b>
086-01837-009	WIREWAY ACCESS PLATE 1/2" CONDUIT, SST	200/208V	1,2,3,5
		230/240V	1,2,3,7.5
		460V	1,2,3,5,7.5,10,15
086-01837-010	WIREWAY ACCESS PLATE 3/4" CONDUIT, SST	200/208V	7.5,10,15
		230/240V	10,15
		460V	20,25,30,40
		200/208V	20,25
		230/240V	25,30
		460V	50,60
086-01837-011	WIREWAY ACCESS PLATE 1" CONDUIT, SST	200/208V	20,25
		230/240V	20,25,30
		460V	50,60
<b>SINGLE POINT POWER MOTOR CUTOUTS, 2" WIREWAYS.</b>			
<b>PART NUMBER</b>	<b>DESCRIPTION</b>	<b>MOTOR VOLTAGE</b>	<b>HP</b>
086-01837-013	WIREWAY ACCESS PLATE 1/2" CONDUIT, SST	200/208V	1,2,3,5
		230/240V	1,2,3,5,7.5
		460V	1,2,3,5,7.5,10,15
086-01837-014	WIREWAY ACCESS PLATE 3/4" CONDUIT, SST	200/208V	7.5,10,15
		230/240V	10,15
		460V	20,25,30,40,

<b>CUTOUT IN 4" WIREWAYS ONLY.</b>	
<b>PART NUMBER</b>	<b>DESCRIPTION</b>
086-01837-008	WIREWAY ACCESS PLATE, BLANK.
<b>LIGHTING CUTOUT, 4" WIREWAYS ONLY.</b>	
<b>PART NUMBER</b>	<b>DESCRIPTION</b>
086-01837-009	WIREWAY ACCESS PLATE 1/2" CONDUIT.
<b>SHIPPING SPLIT CUTOUT BETWEEN 2" WIREWAYS ONLY.</b>	
<b>PART NUMBER</b>	<b>DESCRIPTION</b>
086-01837-012	WIREWAY ACCESS PLATE, BLANK.
<b>LIGHTING CUTOUT, 2" WIREWAYS ONLY.</b>	
<b>PART NUMBER</b>	<b>DESCRIPTION</b>
086-01837-013	WIREWAY ACCESS PLATE 1/2" CONDUIT.

## FILTERS

SIZE	EFF	TYPE	LOAD	PART NUMBER	DESCRIPTION	QTY/ CARTON	WEIGHT
12W x 24H x 11.5D	99.97	HEPA	FRONT	026-33587-005	Filter, HEPA, 12w x 24h x 11.5d		25.00
12W x 24H x 11.5D	99.99	HEPA	FRONT	026-33587-105	Filter, HEPA, 12w x 24h x 11.5d		25.00
12W x 30H x 11.5D	99.97	HEPA	FRONT	026-33587-006	Filter, HEPA, 12w x 30h x 11.5d		30.00
12W x 30H x 11.5D	99.99	HEPA	FRONT	026-33587-106	Filter, HEPA, 12w x 30h x 11.5d		30.00
15W x 24H x 11.5D	99.97	HEPA	FRONT	026-40824-001	Filter, HEPA, 15w x 24h x 11.5d		30.00
15W x 24H x 11.5D	99.99	HEPA	FRONT	026-40824-101	Filter, HEPA, 15w x 24h x 11.5d		30.00
15W x 30H x 11.5D	99.97	HEPA	FRONT	026-40824-002	Filter, HEPA, 15w x 30h x 11.5d		38.00
15W x 30H x 11.5D	99.99	HEPA	FRONT	026-40824-102	Filter, HEPA, 15w x 30h x 11.5d		38.00
24W x 24H x 11.5D	99.97	HEPA	FRONT	026-33587-003	Filter, HEPA, 24w x 24h x 11.5d		40.00
24W x 24H x 11.5D	99.99	HEPA	FRONT	026-33587-103	Filter, HEPA, 24w x 24h x 11.5d		40.00
24W x 12H x 11.5D	99.97	HEPA	FRONT	026-33587-001	Filter, HEPA, 24w x 12h x 11.5d		25.00
24W x 12H x 11.5D	99.99	HEPA	FRONT	026-33587-101	Filter, HEPA, 24w x 12h x 11.5d		25.00
24W x 15H x 11.5D	99.97	HEPA	FRONT	026-33587-002	Filter, HEPA, 24w x 15h x 11.5d		30.00
24W x 15H x 11.5D	99.99	HEPA	FRONT	026-33587-102	Filter, HEPA, 24w x 15h x 11.5d		30.00
24W x 30H x 11.5D	99.97	HEPA	FRONT	026-33587-004	Filter, HEPA, 24w x 30h x 11.5d		45.00
24W x 30H x 11.5D	99.99	HEPA	FRONT	026-33587-104	Filter, HEPA, 24w x 30h x 11.5d		45.00
30W x 24H x 11.5D	99.97	HEPA	FRONT	026-33587-009	Filter, HEPA, 30w x 24h x 11.5d		45.00
30W x 24H x 11.5D	99.99	HEPA	FRONT	026-33587-109	Filter, HEPA, 30w x 24h x 11.5d		45.00
30W x 12H x 11.5D	99.97	HEPA	FRONT	026-33587-007	Filter, HEPA, 30w x 12h x 11.5d		30.00
30W x 12H x 11.5D	99.99	HEPA	FRONT	026-33587-107	Filter, HEPA, 30w x 12h x 11.5d		30.00
30W x 15H x 11.5D	99.97	HEPA	FRONT	026-33587-008	Filter, HEPA, 30w x 15h x 11.5d		38.00
30W x 15H x 11.5D	99.99	HEPA	FRONT	026-33587-108	Filter, HEPA, 30w x 15h x 11.5d		38.00
30W x 30H x 11.5D	99.97	HEPA	FRONT	026-33587-010	Filter, HEPA, 30w x 30h x 11.5d		50.00
30W x 30H x 11.5D	99.99	HEPA	FRONT	026-33587-110	Filter, HEPA, 30w x 30h x 11.5d		50.00
12W x 24H x 22D	60	BAG	REAR	026-32405-019	Filter, Bag, 12w x 24h x 22d, 60-65%	4	4.50
12W x 24H x 22D	80	BAG	REAR	026-32405-021	Filter, Bag, 12w x 24h x 22d, 80-85%	4	4.50
12W x 24H x 22D	90	BAG	REAR	026-32405-023	Filter, Bag, 12w x 24h x 22d, 90-95%	4	4.50
16W x 20H x 22D	60	BAG	REAR	026-32405-037	Filter, Bag, 16w x 20h x 22d, 60-65%	4	3.50
16W x 20H x 22D	80	BAG	REAR	026-32405-038	Filter, Bag, 16w x 20h x 22d, 80-85%	4	3.50
16W x 20H x 22D	90	BAG	REAR	026-32405-039	Filter, Bag, 16w x 20h x 22d, 90-95%	4	3.50
20W x 20H x 22D	60	BAG	REAR	026-32405-001	Filter, Bag, 20w x 20h x 22d, 60-65%	4	4.80
20W x 20H x 22D	80	BAG	REAR	026-32405-004	Filter, Bag, 20w x 20h x 22d, 80-85%	4	4.80
20W x 20H x 22D	90	BAG	REAR	026-32405-007	Filter, Bag, 20w x 20h x 22d, 90-95%	4	4.80
20W x 24H x 22D	60	BAG	REAR	026-32405-002	Filter, Bag, 20w x 24h x 22d, 60-65%	4	5.50
20W x 24H x 22D	80	BAG	REAR	026-32405-005	Filter, Bag, 20w x 24h x 22d, 80-85%	4	5.50
20W x 24H x 22D	90	BAG	REAR	026-32405-008	Filter, Bag, 20w x 24h x 22d, 90-95%	4	5.50
20W x 16H x 22D	60	BAG	REAR	026-32405-040	Filter, Bag, 20w x 16h x 22d, 60-65%	4	3.50
20W x 16H x 22D	80	BAG	REAR	026-32405-041	Filter, Bag, 20w x 16h x 22d, 80-85%	4	3.50
20W x 16H x 22D	90	BAG	REAR	026-32405-042	Filter, Bag, 20w x 16h x 22d, 90-95%	4	3.50
24W x 20H x 22D	60	BAG	REAR	026-32405-031	Filter, Bag, 24w x 20h x 22d, 60-65%	4	5.50
24W x 20H x 22D	80	BAG	REAR	026-32405-032	Filter, Bag, 24w x 20h x 22d, 80-85%	4	5.50
24W x 20H x 22D	90	BAG	REAR	026-32405-033	Filter, Bag, 24w x 20h x 22d, 90-95%	4	5.50
24W x 24H x 22D	60	BAG	REAR	026-32405-020	Filter, Bag, 24w x 24h x 22d, 60-65%	4	8.00
24W x 24H x 22D	80	BAG	REAR	026-32405-022	Filter, Bag, 24w x 24h x 22d, 80-85%	4	8.00

Continued on next page

## FILTERS (CONTINUED)

SIZE	EFF	TYPE	LOAD	PART NUMBER	DESCRIPTION	QTY/ CARTON	WEIGHT
24W x 24H x 22D	90	BAG	REAR	026-32405-024	Filter, Bag, 24w x 24h x 22d, 90-95%	4	8.00
24W x 12H x 22D	60	BAG	REAR	026-32405-003	Filter, Bag, 24w x 12h x 22d, 60-65%	4	4.50
24W x 12H x 22D	80	BAG	REAR	026-32405-006	Filter, Bag, 24w x 12h x 22d, 80-85%	4	4.50
24W x 12H x 22D	90	BAG	REAR	026-32405-009	Filter, Bag, 24w x 12h x 22d, 90-95%	4	4.50
12W x 24H x 4D	60	MINI-PLEAT	REAR	026-33782-001	Filter, Varicel, (Mini Pleated), 12w x 24h x 4d, 60-65%	4	3.30
12W x 24H x 4D	80	MINI-PLEAT	REAR	026-32410-008	Filter, Varicel, (Mini Pleated), 12w x 24h x 4d, 80-85%	4	3.30
12W x 24H x 4D	90	MINI-PLEAT	REAR	026-33783-001	Filter, Varicel, (Mini Pleated), 12w x 24h x 4d, 90-95%	4	3.30
16W x 20H x 4D	60	MINI-PLEAT	REAR	026-33782-002	Filter, Varicel, (Mini Pleated), 16w x 20h x 4d, 60-65%	4	3.50
16W x 20H x 4D	80	MINI-PLEAT	REAR	026-32410-009	Filter, Varicel, (Mini Pleated), 16w x 20h x 4d, 80-85%	4	3.50
16W x 20H x 4D	90	MINI-PLEAT	REAR	026-33783-002	Filter, Varicel, (Mini Pleated), 16w x 20h x 4d, 90-95%	4	3.50
20W x 20H x 4D	60	MINI-PLEAT	REAR	026-33782-005	Filter, Varicel, (Mini Pleated), 20w x 20h x 4d, 60-65%	4	4.50
20W x 20H x 4D	80	MINI-PLEAT	REAR	026-32410-011	Filter, Varicel, (Mini Pleated), 20w x 20h x 4d, 80-85%	4	4.50
20W x 20H x 4D	90	MINI-PLEAT	REAR	026-33783-005	Filter, Varicel, (Mini Pleated), 20w x 20h x 4d, 90-95%	4	4.50
20W x 24H x 4D	60	MINI-PLEAT	REAR	026-33782-006	Filter, Varicel, (Mini Pleated), 20w x 24h x 4d, 60-65%	4	5.30
20W x 24H x 4D	80	MINI-PLEAT	REAR	026-32410-012	Filter, Varicel, (Mini Pleated), 20w x 24h x 4d, 80-85%	4	5.30
20W x 24H x 4D	90	MINI-PLEAT	REAR	026-33783-006	Filter, Varicel, (Mini Pleated), 20w x 24h x 4d, 90-95%	4	5.30
20W x 16H x 4D	60	MINI-PLEAT	REAR	026-33782-002	Filter, Varicel, (Mini Pleated), 16w x 20h x 4d, 60-65%	4	3.50
20W x 16H x 4D	80	MINI-PLEAT	REAR	026-32410-009	Filter, Varicel, (Mini Pleated), 16w x 20h x 4d, 80-85%	4	3.50
20W x 16H x 4D	90	MINI-PLEAT	REAR	026-33783-002	Filter, Varicel, (Mini Pleated), 16w x 20h x 4d, 90-95%	4	3.50
24W x 20H x 4D	60	MINI-PLEAT	REAR	026-33782-006	Filter, Varicel, (Mini Pleated), 20w x 24h x 4d, 60-65%	4	5.30
24W x 20H x 4D	80	MINI-PLEAT	REAR	026-32410-012	Filter, Varicel, (Mini Pleated), 20w x 24h x 4d, 80-85%	4	5.30
24W x 20H x 4D	90	MINI-PLEAT	REAR	026-33783-006	Filter, Varicel, (Mini Pleated), 20w x 24h x 4d, 90-95%	4	5.30
24W x 24H x 4D	60	MINI-PLEAT	REAR	026-33782-008	Filter, Varicel, (Mini Pleated), 24w x 24h x 4d, 60-65%	4	6.50
24W x 24H x 4D	80	MINI-PLEAT	REAR	026-32410-014	Filter, Varicel, (Mini Pleated), 24w x 24h x 4d, 80-85%	4	6.50
24W x 24H x 4D	90	MINI-PLEAT	REAR	026-33783-008	Filter, Varicel, (Mini Pleated), 24w x 24h x 4d, 90-95%	4	6.50
24W x 12H x 4D	60	MINI-PLEAT	REAR	026-33782-001	Filter, Varicel, (Mini Pleated), 12w x 24h x 4d, 60-65%	4	3.30
24W x 12H x 4D	80	MINI-PLEAT	REAR	026-32410-008	Filter, Varicel, (Mini Pleated), 12w x 24h x 4d, 80-85%	4	3.30
24W x 12H x 4D	90	MINI-PLEAT	REAR	026-33783-001	Filter, Varicel, (Mini Pleated), 12w x 24h x 4d, 90-95%	4	3.30
12W x 24H x 12D	90	RIGID	REAR	026-40200-011	Filetr, Cart, Varicel x Dh, 12w x 24h x 12d, 90-95%	1	11.50
12W x 24H x 12D	80	RIGID	REAR	026-40200-009	Filetr, Cart, Varicel x Dh, 12w x 24h x 12d, 80-85%	1	10.50
12W x 24H x 12D	60	RIGID	REAR	026-40200-007	Filetr, Cart, Varicel x Dh, 12w x 24h x 12d, 60-65%	1	10.50
16W x 20H x 12D	90	RIGID	REAR	026-40200-015	Filetr, Cart, Varicel x Dh, 16w x 20h x 12d, 90-95%	1	12.00
16W x 20H x 12D	80	RIGID	REAR	026-40200-013	Filetr, Cart, Varicel x Dh, 16w x 20h x 12d, 80-85%	1	11.00
16W x 20H x 12D	60	RIGID	REAR	026-40200-014	Filetr, Cart, Varicel x Dh, 16w x 20h x 12d, 60-65%	1	11.00
20W x 20H x 12D	90	RIGID	REAR	026-40200-005	Filetr, Cart, Varicel x Dh, 20w x 20h x 12d, 90-95%	1	14.00
20W x 20H x 12D	80	RIGID	REAR	026-40200-003	Filetr, Cart, Varicel x Dh, 20w x 20h x 12d, 80-85%	1	13.00
20W x 20H x 12D	60	RIGID	REAR	026-40200-001	Filetr, Cart, Varicel x Dh, 20w x 20h x 12d, 60-65%	1	13.00
20W x 24H x 12D	90	RIGID	REAR	026-40200-006	Filetr, Cart, Varicel x Dh, 20w x 24h x 12d, 90-95%	1	16.50
20W x 24H x 12D	80	RIGID	REAR	026-40200-004	Filetr, Cart, Varicel x Dh, 20w x 24h x 12d, 80-85%	1	15.50
20W x 24H x 12D	60	RIGID	REAR	026-40200-002	Filetr, Cart, Varicel x Dh, 20w x 24h x 12d, 60-65%	1	15.50
20W x 16H x 12D	90	RIGID	REAR	026-40200-015	Filetr, Cart, Varicel x Dh, 16w x 20h x 12d, 90-95%	1	12.00
20W x 16H x 12D	80	RIGID	REAR	026-40200-013	Filetr, Cart, Varicel x Dh, 16w x 20h x 12d, 80-85%	1	11.00
20W x 16H x 12D	60	RIGID	REAR	026-40200-014	Filetr, Cart, Varicel x Dh, 16w x 20h x 12d, 60-65%	1	11.00
24W x 20H x 12D	90	RIGID	REAR	026-40200-006	Filetr, Cart, Varicel x Dh, 20w x 24h x 12d, 90-95%	1	16.50
24W x 20H x 12D	80	RIGID	REAR	026-40200-004	Filetr, Cart, Varicel x Dh, 20w x 24h x 12d, 80-85%	1	15.50
24W x 20H x 12D	60	RIGID	REAR	026-40200-002	Filetr, Cart, Varicel x Dh, 20w x 24h x 12d, 60-65%	1	15.50
24W x 24H x 12D	90	RIGID	REAR	026-40200-012	Filetr, Cart, Varicel x Dh, 24w x 24h x 12d, 90-95%	1	19.00

Continued on next page

### FILTERS (CONTINUED)

SIZE	EFF	TYPE	LOAD	PART NUMBER	DESCRIPTION	QTY/ CARTON	WEIGHT
24W x 24H x 12D	80	RIGID	REAR	026-40200-010	Filetr, Cart, Varicel x Dh, 24w x 24h x 12d, 80-85%	1	18.00
24W x 24H x 12D	60	RIGID	REAR	026-40200-008	Filetr, Cart, Varicel x Dh, 24w x 24h x 12d, 60-65%	1	18.00
24W x 12H x 12D	90	RIGID	REAR	026-40200-011	Filetr, Cart, Varicel x Dh, 12w x 24h x 12d, 90-95%	1	11.50
24W x 12H x 12D	80	RIGID	REAR	026-40200-009	Filetr, Cart, Varicel x Dh, 12w x 24h x 12d, 80-85%	1	10.50
24W x 12H x 12D	60	RIGID	REAR	026-40200-007	Filetr, Cart, Varicel x Dh, 12w x 24h x 12d, 60-65%	1	10.50
12W x 24H x 22D	60	BAG	SIDEFRT	026-32405-019	Filter, Bag, 12w x 24h x 22d, 60-65%	4	4.50
12W x 24H x 22D	80	BAG	SIDEFRT	026-32405-021	Filter, Bag, 12w x 24h x 22d, 80-85%	4	4.50
12W x 24H x 22D	90	BAG	SIDEFRT	026-32405-023	Filter, Bag, 12w x 24h x 22d, 90-95%	4	4.50
16W x 20H x 22D	60	BAG	SIDEFRT	026-32405-037	Filter, Bag, 16w x 20h x 22d, 60-65%	4	3.50
16W x 20H x 22D	80	BAG	SIDEFRT	026-32405-038	Filter, Bag, 16w x 20h x 22d, 80-85%	4	3.50
16W x 20H x 22D	90	BAG	SIDEFRT	026-32405-039	Filter, Bag, 16w x 20h x 22d, 90-95%	4	3.50
20W x 20H x 22D	60	BAG	SIDEFRT	026-32405-001	Filter, Bag, 20w x 20h x 22d, 60-65%	4	4.80
20W x 20H x 22D	80	BAG	SIDEFRT	026-32405-004	Filter, Bag, 20w x 20h x 22d, 80-85%	4	4.80
20W x 20H x 22D	90	BAG	SIDEFRT	026-32405-007	Filter, Bag, 20w x 20h x 22d, 90-95%	4	4.80
20W x 24H x 22D	60	BAG	SIDEFRT	026-32405-002	Filter, Bag, 20w x 24h x 22d, 60-65%	4	5.50
20W x 24H x 22D	80	BAG	SIDEFRT	026-32405-005	Filter, Bag, 20w x 24h x 22d, 80-85%	4	5.50
20W x 24H x 22D	90	BAG	SIDEFRT	026-32405-008	Filter, Bag, 20w x 24h x 22d, 90-95%	4	5.50
20W x 16H x 22D	60	BAG	SIDEFRT	026-32405-040	Filter, Bag, 20w x 16h x 22d, 60-65%	4	3.50
20W x 16H x 22D	80	BAG	SIDEFRT	026-32405-041	Filter, Bag, 20w x 16h x 22d, 80-85%	4	3.50
20W x 16H x 22D	90	BAG	SIDEFRT	026-32405-042	Filter, Bag, 20w x 16h x 22d, 90-95%	4	3.50
24W x 20H x 22D	60	BAG	SIDEFRT	026-32405-031	Filter, Bag, 24w x 20h x 22d, 60-65%	4	5.50
24W x 20H x 22D	80	BAG	SIDEFRT	026-32405-032	Filter, Bag, 24w x 20h x 22d, 80-85%	4	5.50
24W x 20H x 22D	90	BAG	SIDEFRT	026-32405-033	Filter, Bag, 24w x 20h x 22d, 90-95%	4	5.50
24W x 24H x 22D	60	BAG	SIDEFRT	026-32405-020	Filter, Bag, 24w x 24h x 22d, 60-65%	4	8.00
24W x 24H x 22D	80	BAG	SIDEFRT	026-32405-022	Filter, Bag, 24w x 24h x 22d, 80-85%	4	8.00
24W x 24H x 22D	90	BAG	SIDEFRT	026-32405-024	Filter, Bag, 24w x 24h x 22d, 90-95%	4	8.00
24W x 12H x 22D	60	BAG	SIDEFRT	026-32405-003	Filter, Bag, 24w x 12h x 22d, 60-65%	4	4.50
24W x 12H x 22D	80	BAG	SIDEFRT	026-32405-006	Filter, Bag, 24w x 12h x 22d, 80-85%	4	4.50
24W x 12H x 22D	90	BAG	SIDEFRT	026-32405-009	Filter, Bag, 24w x 12h x 22d, 90-95%	4	4.50
12W x 24H x 2D	NA	CLEANABLE	SIDEFRT	026-32408-001	Filter, Cleanable, 12w x 24h x 2d, Alum	12	1.50
16W x 20H x 2D	NA	CLEANABLE	SIDEFRT	026-10448-000	Filter, Cleanable, 16w x 20h x 2d, Alum	6	1.60
20W x 20H x 2D	NA	CLEANABLE	SIDEFRT	026-10450-000	Filter, Cleanable, 20w x 20h x 2d, Alum	6	2.00
20W x 24H x 2D	NA	CLEANABLE	SIDEFRT	026-32408-009	Filter, Cleanable, 20w x 24h x 2d, Alum	6	2.10
20W x 16H x 2D	NA	CLEANABLE	SIDEFRT	026-10448-000	Filter, Cleanable, 16w x 20h x 2d, Alum	6	1.60
24W x 20H x 2D	NA	CLEANABLE	SIDEFRT	026-32408-009	Filter, Cleanable, 20w x 24h x 2d, Alum	6	2.10
24W x 24H x 2D	NA	CLEANABLE	SIDEFRT	026-32408-002	Filter, Cleanable, 24w x 24h x 2d, Alum	6	2.60
24W x 12H x 2D	NA	CLEANABLE	SIDEFRT	026-32408-001	Filter, Cleanable, 12w x 24h x 2d, Alum	12	1.50
12W x 24H x 4D	60	MINI-PLEAT	SIDEFRT	026-33782-001	Filter, Varicel, (Mini Pleated), 12w x 24h x 4d, 60-65%	4	3.30
12W x 24H x 4D	80	MINI-PLEAT	SIDEFRT	026-32410-008	Filter, Varicel, (Mini Pleated), 12w x 24h x 4d, 80-85%	4	3.30
12W x 24H x 4D	90	MINI-PLEAT	SIDEFRT	026-33783-001	Filter, Varicel, (Mini Pleated), 12w x 24h x 4d, 90-95%	4	3.30
16W x 20H x 4D	60	MINI-PLEAT	SIDEFRT	026-33782-002	Filter, Varicel, (Mini Pleated), 16w x 20h x 4d, 60-65%	4	3.50
16W x 20H x 4D	80	MINI-PLEAT	SIDEFRT	026-32410-009	Filter, Varicel, (Mini Pleated), 16w x 20h x 4d, 80-85%	4	3.50
16W x 20H x 4D	90	MINI-PLEAT	SIDEFRT	026-33783-002	Filter, Varicel, (Mini Pleated), 16w x 20h x 4d, 90-95%	4	3.50
20W x 20H x 4D	60	MINI-PLEAT	SIDEFRT	026-33782-005	Filter, Varicel, (Mini Pleated), 20w x 20h x 4d, 60-65%	4	4.50
20W x 20H x 4D	80	MINI-PLEAT	SIDEFRT	026-32410-011	Filter, Varicel, (Mini Pleated), 20w x 20h x 4d, 80-85%	4	4.50
20W x 20H x 4D	90	MINI-PLEAT	SIDEFRT	026-33783-005	Filter, Varicel, (Mini Pleated), 20w x 20h x 4d, 90-95%	4	4.50
20W x 24H x 4D	60	MINI-PLEAT	SIDEFRT	026-33782-006	Filter, Varicel, (Mini Pleated), 20w x 24h x 4d, 60-65%	4	5.30

Continued on next page

**FILTERS (CONTINUED)**

SIZE	EFF	TYPE	LOAD	PART NUMBER	DESCRIPTION	QTY/ CARTON	WEIGHT
20W x 24H x 4D	80	MINI-PLEAT	SIDEFRT	026-32410-012	Filter, Varicel, (Mini Pleated), 20w x 24h x 4d, 80-85%	4	5.30
20W x 24H x 4D	90	MINI-PLEAT	SIDEFRT	026-33783-006	Filter, Varicel, (Mini Pleated), 20w x 24h x 4d, 90-95%	4	5.30
20W x 16H x 4D	60	MINI-PLEAT	SIDEFRT	026-33782-002	Filter, Varicel, (Mini Pleated), 16w x 20h x 4d, 60-65%	4	3.50
20W x 16H x 4D	80	MINI-PLEAT	SIDEFRT	026-32410-009	Filter, Varicel, (Mini Pleated), 16w x 20h x 4d, 80-85%	4	3.50
20W x 16H x 4D	90	MINI-PLEAT	SIDEFRT	026-33783-002	Filter, Varicel, (Mini Pleated), 16w x 20h x 4d, 90-95%	4	3.50
24W x 20H x 4D	60	MINI-PLEAT	SIDEFRT	026-33782-006	Filter, Varicel, (Mini Pleated), 20w x 24h x 4d, 60-65%	4	5.30
24W x 20H x 4D	80	MINI-PLEAT	SIDEFRT	026-32410-012	Filter, Varicel, (Mini Pleated), 20w x 24h x 4d, 80-85%	4	5.30
24W x 20H x 4D	90	MINI-PLEAT	SIDEFRT	026-33783-006	Filter, Varicel, (Mini Pleated), 20w x 24h x 4d, 90-95%	4	5.30
24W x 24H x 4D	60	MINI-PLEAT	SIDEFRT	026-33782-008	Filter, Varicel, (Mini Pleated), 24w x 24h x 4d, 60-65%	4	6.50
24W x 24H x 4D	80	MINI-PLEAT	SIDEFRT	026-32410-014	Filter, Varicel, (Mini Pleated), 24w x 24h x 4d, 80-85%	4	6.50
24W x 24H x 4D	90	MINI-PLEAT	SIDEFRT	026-33783-008	Filter, Varicel, (Mini Pleated), 24w x 24h x 4d, 90-95%	4	6.50
24W x 12H x 4D	60	MINI-PLEAT	SIDEFRT	026-33782-001	Filter, Varicel, (Mini Pleated), 12w x 24h x 4d, 60-65%	4	3.30
24W x 12H x 4D	80	MINI-PLEAT	SIDEFRT	026-32410-008	Filter, Varicel, (Mini Pleated), 12w x 24h x 4d, 80-85%	4	3.30
24W x 12H x 4D	90	MINI-PLEAT	SIDEFRT	026-33783-001	Filter, Varicel, (Mini Pleated), 12w x 24h x 4d, 90-95%	4	3.30
12W x 24H x 2D	30	PLEATED	SIDEFRT	026-32406-001	Filter, Perfectpleat, 12w x 24h x 2d, 30% Eff	12	0.70
12W x 24H x 4D	30	PLEATED	SIDEFRT	026-32406-004	Filter, Pleated, 12w x 24h x 4d, 30% Eff	12	1.80
16W x 20H x 2D	30	PLEATED	SIDEFRT	026-21062-000	Filter, Perfectpleat, 16w x 20h x 2d, 30% Eff	12	0.70
16W x 20H x 4D	30	PLEATED	SIDEFRT	026-28200-000	Filter, Pleated, 16w x 20h x 4d, 30% Eff	12	1.80
20W x 20H x 2D	30	PLEATED	SIDEFRT	026-21063-000	Filter, Perfectpleat, 20w x 20h x 2d, 30% Eff	12	0.80
20W x 20H x 4D	30	PLEATED	SIDEFRT	026-28202-000	Filter, Pleated, 20w x 20h x 4d, 30% Eff	12	2.10
20W x 24H x 2D	30	PLEATED	SIDEFRT	026-32406-002	Filter, Perfectpleat, 20w x 24h x 2d, 30% Eff	12	1.00
20W x 24H x 4D	30	PLEATED	SIDEFRT	026-32406-007	Filter, Pleated, 20w x 24h x 4d, 30% Eff	12	2.50
20W x 16H x 2D	30	PLEATED	SIDEFRT	026-32406-010	Filter, Perfectpleat, 20w x 16h x 2d, 30% Eff	12	0.70
20W x 16H x 4D	30	PLEATED	SIDEFRT	026-28200-000	Filter, Pleated, 16w x 20h x 4d, 30% Eff	12	1.80
24W x 20H x 2D	30	PLEATED	SIDEFRT	026-32406-009	Filter, Perfectpleat, 24w x 20h x 2d, 30% Eff	12	1.00
24W x 20H x 4D	30	PLEATED	SIDEFRT	026-32406-007	Filter, Pleated, 20w x 24h x 4d, 30% Eff	12	2.50
24W x 24H x 2D	30	PLEATED	SIDEFRT	026-32406-003	Filter, Perfectpleat, 24w x 24h x 2d, 30% Eff	12	1.10
24W x 24H x 4D	30	PLEATED	SIDEFRT	026-32406-006	Filter, Pleated, 24w x 24h x 4d, 30% Eff	12	2.50
24W x 12H x 2D	30	PLEATED	SIDEFRT	026-32406-008	Filter, Perfectpleat, 24w x 12h x 2d, 30% Eff	12	0.70
24W x 12H x 4D	30	PLEATED	SIDEFRT	026-32406-004	Filter, Pleated, 12w x 24h x 4d, 30% Eff	12	1.80
12W x 24H x 12D	80	RIGID	SIDEFRT	026-32404-009	Filter, Cart, Varicel x Sh, 12w x 24h x 12d, 80-85%	1	10.50
12W x 24H x 12D	90	RIGID	SIDEFRT	026-32404-011	Filter, Cart, Varicel x Sh, 12w x 24h x 12d, 90-95%	1	11.50
12W x 24H x 12D	60	RIGID	SIDEFRT	026-32404-007	Filter, Cart, Varicel x Sh, 12w x 24h x 12d, 60-65%	1	10.50
16W x 20H x 12D	80	RIGID	SIDEFRT	026-32404-013	Filter, Cart, Varicel x Sh, 16w x 20h x 12d, 80-85%	1	11.00
16W x 20H x 12D	90	RIGID	SIDEFRT	026-36342-009	Filter, Cart, Varicel x Sh, 16w x 20h x 12d, 90-95%	1	12.00
16W x 20H x 12D	60	RIGID	SIDEFRT	026-36340-009	Filter, Cart, Varicel x Sh, 16w x 20h x 12d, 60-65%	1	11.00
20W x 20H x 12D	80	RIGID	SIDEFRT	026-32404-003	Filter, Cart, Varicel x Sh, 20w x 20h x 12d, 80-85%	1	13.00
20W x 20H x 12D	90	RIGID	SIDEFRT	026-32404-005	Filter, Cart, Varicel x Sh, 20w x 20h x 12d, 90-95%	1	14.00
20W x 20H x 12D	60	RIGID	SIDEFRT	026-32404-001	Filter, Cart, Varicel x Sh, 20w x 20h x 12d, 60-65%	1	13.00
20W x 24H x 12D	80	RIGID	SIDEFRT	026-32404-004	Filter, Cart, Varicel x Sh, 20w x 24h x 12d, 80-85%	1	15.50
20W x 24H x 12D	90	RIGID	SIDEFRT	026-32404-006	Filter, Cart, Varicel x Sh, 20w x 24h x 12d, 90-95%	1	16.50
20W x 24H x 12D	60	RIGID	SIDEFRT	026-32404-002	Filter, Cart, Varicel x Sh, 20w x 24h x 12d, 60-65%	1	15.50
20W x 16H x 12D	80	RIGID	SIDEFRT	026-32404-013	Filter, Cart, Varicel x Sh, 16w x 20h x 12d, 80-85%	1	11.00
20W x 16H x 12D	90	RIGID	SIDEFRT	026-36342-009	Filter, Cart, Varicel x Sh, 16w x 20h x 12d, 90-95%	1	12.00
20W x 16H x 12D	60	RIGID	SIDEFRT	026-36340-009	Filter, Cart, Varicel x Sh, 16w x 20h x 12d, 60-65%	1	11.00
24W x 20H x 12D	80	RIGID	SIDEFRT	026-32404-004	Filter, Cart, Varicel x Sh, 20w x 24h x 12d, 80-85%	1	15.50

Continued on next page

**FILTERS (CONTINUED)**

SIZE	EFF	TYPE	LOAD	PART NUMBER	DESCRIPTION	QTY/ CARTON	WEIGHT
24W x 20H x 12D	90	RIGID	SIDEFRT	026-32404-006	Filter, Cart, Varicel x Sh, 20w x 24h x 12d, 90-95%	1	16.50
24W x 20H x 12D	60	RIGID	SIDEFRT	026-32404-002	Filter, Cart, Varicel x Sh, 20w x 24h x 12d, 60-65%	1	15.50
24W x 24H x 12D	80	RIGID	SIDEFRT	026-32404-010	Filter, Cart, Varicel x Sh, 24w x 24h x 12d, 80-85%	1	18.00
24W x 24H x 12D	90	RIGID	SIDEFRT	026-32404-012	Filter, Cart, Varicel x Sh, 24w x 24h x 12d, 90-95%	1	19.00
24W x 24H x 12D	60	RIGID	SIDEFRT	026-32404-008	Filter, Cart, Varicel x Sh, 24w x 24h x 12d, 60-65%	1	18.00
24W x 12H x 12D	80	RIGID	SIDEFRT	026-32404-009	Filter, Cart, Varicel x Sh, 12w x 24h x 12d, 80-85%	1	10.50
24W x 12H x 12D	90	RIGID	SIDEFRT	026-32404-011	Filter, Cart, Varicel x Sh, 12w x 24h x 12d, 90-95%	1	11.50
24W x 12H x 12D	60	RIGID	SIDEFRT	026-32404-007	Filter, Cart, Varicel x Sh, 12w x 24h x 12d, 60-65%	1	10.50
12W x 24H x 2D	NA	THROWAWAY	SIDEFRT	026-32407-001	Filter, Throwaway, 12w x 24h x 2d, Fbrgls	12	0.60
16W x 20H x 2D	NA	THROWAWAY	SIDEFRT	026-03617-000	Filter, Throwaway, 16w x 20h x 2d, Fbrgls	12	0.60
20W x 20H x 2D	NA	THROWAWAY	SIDEFRT	026-02043-000	Filter, Throwaway, 20w x 20h x 2d, Fbrgls	12	0.60
20W x 24H x 2D	NA	THROWAWAY	SIDEFRT	026-32407-009	Filter, Throwaway, 20w x 24h x 2d, Fbrgls	12	0.80
20W x 16H x 2D	NA	THROWAWAY	SIDEFRT	026-03617-000	Filter, Throwaway, 16w x 20h x 2d, Fbrgls	12	0.60
24W x 20H x 2D	NA	THROWAWAY	SIDEFRT	026-32407-009	Filter, Throwaway, 20w x 24h x 2d, Fbrgls	12	0.80
24W x 24H x 2D	NA	THROWAWAY	SIDEFRT	026-32407-002	Filter, Throwaway, 24w x 24h x 2d, Fbrgls	12	0.80
24W x 12H x 2D	NA	THROWAWAY	SIDEFRT	026-32407-001	Filter, Throwaway, 12w x 24h x 2d, Fbrgls	12	0.60

<b>OA HOOD MOISTURE ELIMINATOR FILTERS (BY DAMPER SIZE)</b>					
<b>DAMPER HEIGHTH</b>	<b>DAMPER WIDTH</b>	<b>PART_ NUMBER</b>	<b>DESCRIPTION</b>	<b>QTY PER HOOD</b>	<b>QTY PER CARTON</b>
26.75	15.00	026-41366-107	FLTR,CLEANABLE,15W_15H_1D,ALUM	2	12
26.75	22.00	026-41366-001	FLTR,CLEANABLE,15W_16H_1D,ALUM	4	12
26.75	16.00	026-41366-001	FLTR,CLEANABLE,15W_16H_1D,ALUM	2	12
26.75	17.00	026-41366-002	FLTR,CLEANABLE,15W_17H_1D,ALUM	2	12
9.50	21.00	026-41366-108	FLTR,CLEANABLE,15W_18H_1D,ALUM	4	12
32.50	21.00	026-41366-108	FLTR,CLEANABLE,15W_18H_1D,ALUM	4	12
15.25	21.00	026-41366-004	FLTR,CLEANABLE,15W_20H_1D,ALUM	1	12
15.25	22.00	026-41366-004	FLTR,CLEANABLE,15W_20H_1D,ALUM	2	12
38.25	21.00	026-41366-109	FLTR,CLEANABLE,15W_21H_1D,ALUM	4	12
38.25	22.00	026-41366-109	FLTR,CLEANABLE,15W_21H_1D,ALUM	4	12
44.00	22.00	026-41366-007	FLTR,CLEANABLE,15W_24H_1D,ALUM	4	12
44.00	21.00	026-41366-007	FLTR,CLEANABLE,15W_24H_1D,ALUM	4	12
21.00	21.00	026-41366-008	FLTR,CLEANABLE,15W_25H_1D,ALUM	2	2
21.00	22.00	026-41366-008	FLTR,CLEANABLE,15W_25H_1D,ALUM	2	2
49.75	22.00	026-41366-010	FLTR,CLEANABLE,15W_27H_1D,ALUM	4	12
49.75	21.00	026-41366-010	FLTR,CLEANABLE,15W_27H_1D,ALUM	4	12
26.75	19.00	026-41366-110	FLTR,CLEANABLE,15W_28H_1D,ALUM	2	12
26.75	20.00	026-41366-111	FLTR,CLEANABLE,15W_29H_1D,ALUM	2	12
26.75	23.00	026-41366-011	FLTR,CLEANABLE,16W_16H_1D,ALUM	4	12
26.75	24.00	026-41366-011	FLTR,CLEANABLE,16W_16H_1D,ALUM	4	12
26.75	25.00	026-41366-012	FLTR,CLEANABLE,16W_17H_1D,ALUM	4	12
26.75	26.00	026-41366-012	FLTR,CLEANABLE,16W_17H_1D,ALUM	4	12
9.50	24.00	026-41366-013	FLTR,CLEANABLE,16W_18H_1D,ALUM	2	12
26.75	27.00	026-41366-013	FLTR,CLEANABLE,16W_18H_1D,ALUM	4	12
26.75	28.00	026-41366-013	FLTR,CLEANABLE,16W_18H_1D,ALUM	4	12
26.75	29.00	026-41366-014	FLTR,CLEANABLE,16W_19H_1D,ALUM	4	12
26.75	30.00	026-41366-014	FLTR,CLEANABLE,16W_19H_1D,ALUM	4	12
32.50	23.00	026-41366-014	FLTR,CLEANABLE,16W_19H_1D,ALUM	4	12
32.50	24.00	026-41366-014	FLTR,CLEANABLE,16W_19H_1D,ALUM	4	12
15.25	23.00	026-41366-015	FLTR,CLEANABLE,16W_20H_1D,ALUM	2	12
15.25	24.00	026-41366-015	FLTR,CLEANABLE,16W_20H_1D,ALUM	2	12
26.75	31.00	026-41366-015	FLTR,CLEANABLE,16W_20H_1D,ALUM	4	12
26.75	32.00	026-41366-015	FLTR,CLEANABLE,16W_20H_1D,ALUM	4	12
26.75	33.00	026-41366-112	FLTR,CLEANABLE,16W_21H_1D,ALUM	4	12
26.75	34.00	026-41366-112	FLTR,CLEANABLE,16W_21H_1D,ALUM	4	12
26.75	35.00	026-41366-016	FLTR,CLEANABLE,16W_22H_1D,ALUM	4	12
26.75	36.00	026-41366-016	FLTR,CLEANABLE,16W_22H_1D,ALUM	4	12
38.25	24.00	026-41366-016	FLTR,CLEANABLE,16W_22H_1D,ALUM	4	12
26.75	37.00	026-41366-113	FLTR,CLEANABLE,16W_23H_1D,ALUM	4	12
44.00	23.00	026-41366-117	FLTR,CLEANABLE,16W_24H_1D,ALUM	4	12
21.00	23.00	026-41366-018	FLTR,CLEANABLE,16W_25H_1D,ALUM	2	12
21.00	24.00	026-41366-018	FLTR,CLEANABLE,16W_25H_1D,ALUM	2	12
44.00	24.00	026-41366-018	FLTR,CLEANABLE,16W_25H_1D,ALUM	4	12

Continued on next page

<b>OA HOOD MOISTURE ELIMINATOR FILTERS (BY DAMPER SIZE) (CONTINUED)</b>					
<b>DAMPER HEIGHTH</b>	<b>DAMPER WIDTH</b>	<b>PART NUMBER</b>	<b>DESCRIPTION</b>	<b>QTY PER HOOD</b>	<b>QTY PER CARTON</b>
49.75	23.00	026-41366-116	FLTR,CLEANABLE,16W_27H_1D,ALUM	4	12
49.75	24.00	026-41366-020	FLTR,CLEANABLE,16W_28H_1D,ALUM	4	12
38.25	8.00	026-41366-022	FLTR,CLEANABLE,17W_17H_1D,ALUM	2	12
9.50	26.00	026-41366-114	FLTR,CLEANABLE,17W_18H_1D,ALUM	2	12
26.75	48.00	026-41366-023	FLTR,CLEANABLE,17W_19H_1D,ALUM	6	12
26.75	49.00	026-41366-023	FLTR,CLEANABLE,17W_19H_1D,ALUM	6	12
32.50	26.00	026-41366-023	FLTR,CLEANABLE,17W_19H_1D,ALUM	4	12
15.25	26.00	026-41366-024	FLTR,CLEANABLE,17W_20H_1D,ALUM	2	12
26.75	50.00	026-41366-024	FLTR,CLEANABLE,17W_20H_1D,ALUM	6	12
26.75	51.00	026-41366-024	FLTR,CLEANABLE,17W_20H_1D,ALUM	6	12
26.75	52.00	026-41366-024	FLTR,CLEANABLE,17W_20H_1D,ALUM	6	12
26.75	53.00	026-41366-025	FLTR,CLEANABLE,17W_21H_1D,ALUM	6	12
26.75	54.00	026-41366-025	FLTR,CLEANABLE,17W_21H_1D,ALUM	6	12
26.75	55.00	026-41366-025	FLTR,CLEANABLE,17W_21H_1D,ALUM	6	12
26.75	75.00	026-41366-025	FLTR,CLEANABLE,17W_21H_1D,ALUM	8	12
26.75	56.00	026-41366-026	FLTR,CLEANABLE,17W_22H_1D,ALUM	6	12
26.75	57.00	026-41366-026	FLTR,CLEANABLE,17W_22H_1D,ALUM	6	12
26.75	58.00	026-41366-026	FLTR,CLEANABLE,17W_22H_1D,ALUM	6	12
26.75	78.00	026-41366-026	FLTR,CLEANABLE,17W_22H_1D,ALUM	8	12
38.25	25.00	026-41366-026	FLTR,CLEANABLE,17W_22H_1D,ALUM	4	12
26.75	38.00	026-41366-027	FLTR,CLEANABLE,17W_23H_1D,ALUM	4	12
26.75	59.00	026-41366-027	FLTR,CLEANABLE,17W_23H_1D,ALUM	6	12
26.75	60.00	026-41366-027	FLTR,CLEANABLE,17W_23H_1D,ALUM	6	12
26.75	61.00	026-41366-027	FLTR,CLEANABLE,17W_23H_1D,ALUM	6	12
26.75	81.00	026-41366-027	FLTR,CLEANABLE,17W_23H_1D,ALUM	8	12
26.75	84.00	026-41366-027	FLTR,CLEANABLE,17W_23H_1D,ALUM	8	12
26.75	105.00	026-41366-027	FLTR,CLEANABLE,17W_23H_1D,ALUM	10	12
32.50	14.00	026-41366-027	FLTR,CLEANABLE,17W_23H_1D,ALUM	2	12
26.75	39.00	026-41366-028	FLTR,CLEANABLE,17W_24H_1D,ALUM	4	12
26.75	40.00	026-41366-028	FLTR,CLEANABLE,17W_24H_1D,ALUM	4	12
26.75	62.00	026-41366-028	FLTR,CLEANABLE,17W_24H_1D,ALUM	6	12
26.75	63.00	026-41366-028	FLTR,CLEANABLE,17W_24H_1D,ALUM	6	12
26.75	64.00	026-41366-028	FLTR,CLEANABLE,17W_24H_1D,ALUM	6	12
26.75	87.00	026-41366-028	FLTR,CLEANABLE,17W_24H_1D,ALUM	8	12
26.75	108.00	026-41366-028	FLTR,CLEANABLE,17W_24H_1D,ALUM	10	12
26.75	111.00	026-41366-028	FLTR,CLEANABLE,17W_24H_1D,ALUM	10	12
32.50	15.00	026-41366-028	FLTR,CLEANABLE,17W_24H_1D,ALUM	2	12
21.00	25.00	026-41366-029	FLTR,CLEANABLE,17W_25H_1D,ALUM	2	12
21.00	26.00	026-41366-029	FLTR,CLEANABLE,17W_25H_1D,ALUM	2	12
26.75	41.00	026-41366-029	FLTR,CLEANABLE,17W_25H_1D,ALUM	4	12
26.75	42.00	026-41366-029	FLTR,CLEANABLE,17W_25H_1D,ALUM	4	12
26.75	65.00	026-41366-029	FLTR,CLEANABLE,17W_25H_1D,ALUM	6	12
26.75	66.00	026-41366-029	FLTR,CLEANABLE,17W_25H_1D,ALUM	6	12

Continued on next page



<b>OA HOOD MOISTURE ELIMINATOR FILTERS (BY DAMPER SIZE) (CONTINUED)</b>					
<b>DAMPER HEIGHTH</b>	<b>DAMPER WIDTH</b>	<b>PART NUMBER</b>	<b>DESCRIPTION</b>	<b>QTY PER HOOD</b>	<b>QTY PER CARTON</b>
26.75	90.00	026-41366-029	FLTR,CLEANABLE,17W_25H_1D,ALUM	8	12
44.00	25.00	026-41366-029	FLTR,CLEANABLE,17W_25H_1D,ALUM	4	12
44.00	26.00	026-41366-029	FLTR,CLEANABLE,17W_25H_1D,ALUM	4	12
26.75	43.00	026-41366-030	FLTR,CLEANABLE,17W_26H_1D,ALUM	4	12
26.75	44.00	026-41366-030	FLTR,CLEANABLE,17W_26H_1D,ALUM	4	12
26.75	68.00	026-41366-030	FLTR,CLEANABLE,17W_26H_1D,ALUM	6	12
26.75	69.00	026-41366-030	FLTR,CLEANABLE,17W_26H_1D,ALUM	6	12
26.75	93.00	026-41366-030	FLTR,CLEANABLE,17W_26H_1D,ALUM	8	12
26.75	96.00	026-41366-030	FLTR,CLEANABLE,17W_26H_1D,ALUM	8	12
26.75	45.00	026-41366-031	FLTR,CLEANABLE,17W_27H_1D,ALUM	4	12
26.75	46.00	026-41366-031	FLTR,CLEANABLE,17W_27H_1D,ALUM	4	12
26.75	71.00	026-41366-031	FLTR,CLEANABLE,17W_27H_1D,ALUM	6	12
26.75	72.00	026-41366-031	FLTR,CLEANABLE,17W_27H_1D,ALUM	6	12
26.75	99.00	026-41366-031	FLTR,CLEANABLE,17W_27H_1D,ALUM	8	12
49.75	26.00	026-41366-031	FLTR,CLEANABLE,17W_27H_1D,ALUM	4	12
26.75	47.00	026-41366-032	FLTR,CLEANABLE,17W_28H_1D,ALUM	4	12
26.75	74.00	026-41366-032	FLTR,CLEANABLE,17W_28H_1D,ALUM	6	12
26.75	102.00	026-41366-032	FLTR,CLEANABLE,17W_28H_1D,ALUM	8	12
9.50	27.00	026-41366-033	FLTR,CLEANABLE,18W_18H_1D,ALUM	2	12
15.25	9.00	026-41366-033	FLTR,CLEANABLE,18W_18H_1D,ALUM	1	12
9.50	29.00	026-41366-034	FLTR,CLEANABLE,18W_19H_1D,ALUM	2	12
9.50	30.00	026-41366-034	FLTR,CLEANABLE,18W_19H_1D,ALUM	2	12
9.50	48.00	026-41366-034	FLTR,CLEANABLE,18W_19H_1D,ALUM	3	12
15.25	10.00	026-41366-034	FLTR,CLEANABLE,18W_19H_1D,ALUM	1	12
32.50	27.00	026-41366-034	FLTR,CLEANABLE,18W_19H_1D,ALUM	4	12
32.50	28.00	026-41366-034	FLTR,CLEANABLE,18W_19H_1D,ALUM	4	12
9.50	31.00	026-41366-035	FLTR,CLEANABLE,18W_20H_1D,ALUM	2	12
9.50	51.00	026-41366-035	FLTR,CLEANABLE,18W_20H_1D,ALUM	3	12
15.25	27.00	026-41366-035	FLTR,CLEANABLE,18W_20H_1D,ALUM	2	12
9.50	12.00	026-41366-036	FLTR,CLEANABLE,18W_21H_1D,ALUM	1	12
9.50	33.00	026-41366-036	FLTR,CLEANABLE,18W_21H_1D,ALUM	2	12
9.50	54.00	026-41366-036	FLTR,CLEANABLE,18W_21H_1D,ALUM	3	12
15.25	12.00	026-41366-036	FLTR,CLEANABLE,18W_21H_1D,ALUM	1	12
15.25	28.00	026-41366-036	FLTR,CLEANABLE,18W_21H_1D,ALUM	2	12
9.50	36.00	026-41366-037	FLTR,CLEANABLE,18W_22H_1D,ALUM	2	12
9.50	57.00	026-41366-037	FLTR,CLEANABLE,18W_22H_1D,ALUM	3	12
38.25	27.00	026-41366-037	FLTR,CLEANABLE,18W_22H_1D,ALUM	4	12
38.25	28.00	026-41366-037	FLTR,CLEANABLE,18W_22H_1D,ALUM	4	12
9.50	14.00	026-41366-038	FLTR,CLEANABLE,18W_23H_1D,ALUM	1	12
9.50	15.00	026-41366-039	FLTR,CLEANABLE,18W_24H_1D,ALUM	1	12
9.50	39.00	026-41366-039	FLTR,CLEANABLE,18W_24H_1D,ALUM	2	12
9.50	42.00	026-41366-040	FLTR,CLEANABLE,18W_25H_1D,ALUM	2	12

Continued on next page

<b>OA HOOD MOISTURE ELIMINATOR FILTERS (BY DAMPER SIZE) (CONTINUED)</b>					
<b>DAMPER HEIGHTH</b>	<b>DAMPER WIDTH</b>	<b>PART NUMBER</b>	<b>DESCRIPTION</b>	<b>QTY PER HOOD</b>	<b>QTY PER CARTON</b>
21.00	27.00	026-41366-040	FLTR,CLEANABLE,18W_25H_1D,ALUM	2	12
26.75	114.00	026-41366-040	FLTR,CLEANABLE,18W_25H_1D,ALUM	10	12
26.75	117.00	026-41366-040	FLTR,CLEANABLE,18W_25H_1D,ALUM	10	12
32.50	16.00	026-41366-040	FLTR,CLEANABLE,18W_25H_1D,ALUM	2	12
44.00	28.00	026-41366-040	FLTR,CLEANABLE,18W_25H_1D,ALUM	4	12
9.50	17.00	026-41366-041	FLTR,CLEANABLE,18W_26H_1D,ALUM	1	12
21.00	28.00	026-41366-041	FLTR,CLEANABLE,18W_26H_1D,ALUM	2	12
26.75	120.00	026-41366-041	FLTR,CLEANABLE,18W_26H_1D,ALUM	10	12
32.50	17.00	026-41366-041	FLTR,CLEANABLE,18W_26H_1D,ALUM	2	12
9.50	18.00	026-41366-042	FLTR,CLEANABLE,18W_27H_1D,ALUM	1	12
9.50	45.00	026-41366-042	FLTR,CLEANABLE,18W_27H_1D,ALUM	2	12
32.50	18.00	026-41366-042	FLTR,CLEANABLE,18W_27H_1D,ALUM	2	12
9.50	19.00	026-41366-043	FLTR,CLEANABLE,18W_28H_1D,ALUM	1	12
32.50	19.00	026-41366-043	FLTR,CLEANABLE,18W_28H_1D,ALUM	2	12
49.75	27.00	026-41366-043	FLTR,CLEANABLE,18W_28H_1D,ALUM	4	12
32.50	20.00	026-41366-115	FLTR,CLEANABLE,18W_29H_1D,ALUM	2	12
32.50	29.00	026-41366-044	FLTR,CLEANABLE,19W_19H_1D,ALUM	4	12
32.50	30.00	026-41366-044	FLTR,CLEANABLE,19W_19H_1D,ALUM	4	12
49.75	30.00	026-41366-044	FLTR,CLEANABLE,19W_19H_1D,ALUM	6	12
32.50	31.00	026-41366-045	FLTR,CLEANABLE,19W_20H_1D,ALUM	4	12
32.50	32.00	026-41366-045	FLTR,CLEANABLE,19W_20H_1D,ALUM	4	12
49.75	48.00	026-41366-045	FLTR,CLEANABLE,19W_20H_1D,ALUM	9	12
49.75	49.00	026-41366-045	FLTR,CLEANABLE,19W_20H_1D,ALUM	9	12
32.50	48.00	026-41366-045	FLTR,CLEANABLE,19W_20H_1D,ALUM	6	12
32.50	49.00	026-41366-045	FLTR,CLEANABLE,19W_20H_1D,ALUM	6	12
15.25	30.00	026-41366-046	FLTR,CLEANABLE,19W_21H_1D,ALUM	2	12
15.25	48.00	026-41366-046	FLTR,CLEANABLE,19W_21H_1D,ALUM	3	12
21.00	10.00	026-41366-046	FLTR,CLEANABLE,19W_21H_1D,ALUM	1	12
32.50	33.00	026-41366-046	FLTR,CLEANABLE,19W_21H_1D,ALUM	4	12
32.50	34.00	026-41366-046	FLTR,CLEANABLE,19W_21H_1D,ALUM	4	12
49.75	33.00	026-41366-046	FLTR,CLEANABLE,19W_21H_1D,ALUM	6	12
32.50	35.00	026-41366-047	FLTR,CLEANABLE,19W_22H_1D,ALUM	4	12
38.25	30.00	026-41366-047	FLTR,CLEANABLE,19W_22H_1D,ALUM	4	12
49.75	36.00	026-41366-047	FLTR,CLEANABLE,19W_22H_1D,ALUM	6	12
15.25	14.00	026-41366-048	FLTR,CLEANABLE,19W_23H_1D,ALUM	1	12
49.75	10.00	026-41366-048	FLTR,CLEANABLE,19W_23H_1D,ALUM	2	12
15.25	16.00	026-41366-050	FLTR,CLEANABLE,19W_25H_1D,ALUM	1	12
44.00	30.00	026-41366-050	FLTR,CLEANABLE,19W_25H_1D,ALUM	4	12
44.00	42.00	026-41366-050	FLTR,CLEANABLE,19W_25H_1D,ALUM	4	12
15.25	17.00	026-41366-051	FLTR,CLEANABLE,19W_26H_1D,ALUM	1	12
21.00	29.00	026-41366-051	FLTR,CLEANABLE,19W_26H_1D,ALUM	2	12
21.00	30.00	026-41366-051	FLTR,CLEANABLE,19W_26H_1D,ALUM	2	12
44.00	48.00	026-41366-051	FLTR,CLEANABLE,19W_26H_1D,ALUM	6	12

Continued on next page

<b>OA HOOD MOISTURE ELIMINATOR FILTERS (BY DAMPER SIZE) (CONTINUED)</b>					
<b>DAMPER HEIGHTH</b>	<b>DAMPER WIDTH</b>	<b>PART NUMBER</b>	<b>DESCRIPTION</b>	<b>QTY PER HOOD</b>	<b>QTY PER CARTON</b>
15.25	18.00	026-41366-052	FLTR,CLEANABLE,19W_27H_1D,ALUM	1	12
21.00	48.00	026-41366-052	FLTR,CLEANABLE,19W_27H_1D,ALUM	3	12
32.50	51.00	026-41366-055	FLTR,CLEANABLE,20W_20H_1D,ALUM	6	12
32.50	52.00	026-41366-055	FLTR,CLEANABLE,20W_20H_1D,ALUM	6	12
49.75	51.00	026-41366-055	FLTR,CLEANABLE,20W_20H_1D,ALUM	12	12
32.50	54.00	026-41366-056	FLTR,CLEANABLE,20W_21H_1D,ALUM	6	12
49.75	53.00	026-41366-056	FLTR,CLEANABLE,20W_21H_1D,ALUM	12	12
15.25	32.00	026-41366-056	FLTR,CLEANABLE,20W_21H_1D,ALUM	2	12
15.25	51.00	026-41366-056	FLTR,CLEANABLE,20W_21H_1D,ALUM	3	12
21.00	11.00	026-41366-057	FLTR,CLEANABLE,20W_22H_1D,ALUM	1	12
32.50	36.00	026-41366-057	FLTR,CLEANABLE,20W_22H_1D,ALUM	4	12
32.50	57.00	026-41366-057	FLTR,CLEANABLE,20W_22H_1D,ALUM	6	12
38.25	31.00	026-41366-057	FLTR,CLEANABLE,20W_22H_1D,ALUM	4	12
38.25	32.00	026-41366-057	FLTR,CLEANABLE,20W_22H_1D,ALUM	4	12
49.75	78.00	026-41366-057	FLTR,CLEANABLE,20W_22H_1D,ALUM	12	12
32.50	37.00	026-41366-058	FLTR,CLEANABLE,20W_23H_1D,ALUM	4	12
32.50	38.00	026-41366-058	FLTR,CLEANABLE,20W_23H_1D,ALUM	4	12
32.50	60.00	026-41366-058	FLTR,CLEANABLE,20W_23H_1D,ALUM	6	12
38.25	50.00	026-41366-058	FLTR,CLEANABLE,20W_23H_1D,ALUM	6	12
49.75	38.00	026-41366-058	FLTR,CLEANABLE,20W_23H_1D,ALUM	6	12
49.75	84.00	026-41366-058	FLTR,CLEANABLE,20W_23H_1D,ALUM	12	12
32.50	40.00	026-41366-058	FLTR,CLEANABLE,20W_23H_1D,ALUM	4	12
32.50	39.00	026-41366-059	FLTR,CLEANABLE,20W_24H_1D,ALUM	4	12
32.50	63.00	026-41366-059	FLTR,CLEANABLE,20W_24H_1D,ALUM	6	12
49.75	39.00	026-41366-059	FLTR,CLEANABLE,20W_24H_1D,ALUM	6	12
49.75	40.00	026-41366-059	FLTR,CLEANABLE,20W_24H_1D,ALUM	6	12
49.75	11.00	026-41366-059	FLTR,CLEANABLE,20W_24H_1D,ALUM	2	12
32.50	41.00	026-41366-060	FLTR,CLEANABLE,20W_25H_1D,ALUM	4	12
32.50	42.00	026-41366-060	FLTR,CLEANABLE,20W_25H_1D,ALUM	4	12
32.50	66.00	026-41366-060	FLTR,CLEANABLE,20W_25H_1D,ALUM	6	12
38.25	16.00	026-41366-060	FLTR,CLEANABLE,20W_25H_1D,ALUM	2	12
44.00	31.00	026-41366-060	FLTR,CLEANABLE,20W_25H_1D,ALUM	4	12
44.00	32.00	026-41366-060	FLTR,CLEANABLE,20W_25H_1D,ALUM	4	12
49.75	41.00	026-41366-060	FLTR,CLEANABLE,20W_25H_1D,ALUM	6	12
49.75	42.00	026-41366-060	FLTR,CLEANABLE,20W_25H_1D,ALUM	6	12
21.00	31.00	026-41366-061	FLTR,CLEANABLE,20W_26H_1D,ALUM	2	12
21.00	32.00	026-41366-061	FLTR,CLEANABLE,20W_26H_1D,ALUM	2	12
32.50	43.00	026-41366-061	FLTR,CLEANABLE,20W_26H_1D,ALUM	4	12
32.50	44.00	026-41366-061	FLTR,CLEANABLE,20W_26H_1D,ALUM	4	12
44.00	51.00	026-41366-061	FLTR,CLEANABLE,20W_26H_1D,ALUM	6	12
49.75	44.00	026-41366-061	FLTR,CLEANABLE,20W_26H_1D,ALUM	6	12
21.00	50.00	026-41366-062	FLTR,CLEANABLE,20W_27H_1D,ALUM	3	12
21.00	51.00	026-41366-062	FLTR,CLEANABLE,20W_27H_1D,ALUM	3	12

Continued on next page

<b>OA HOOD MOISTURE ELIMINATOR FILTERS (BY DAMPER SIZE) (CONTINUED)</b>					
<b>DAMPER HEIGHTH</b>	<b>DAMPER WIDTH</b>	<b>PART NUMBER</b>	<b>DESCRIPTION</b>	<b>QTY PER HOOD</b>	<b>QTY PER CARTON</b>
32.50	45.00	026-41366-062	FLTR,CLEANABLE,20W_27H_1D,ALUM	4	12
32.50	46.00	026-41366-062	FLTR,CLEANABLE,20W_27H_1D,ALUM	4	12
32.50	72.00	026-41366-062	FLTR,CLEANABLE,20W_27H_1D,ALUM	6	12
49.75	45.00	026-41366-062	FLTR,CLEANABLE,20W_27H_1D,ALUM	6	12
49.75	46.00	026-41366-062	FLTR,CLEANABLE,20W_27H_1D,ALUM	6	12
15.25	19.00	026-41366-063	FLTR,CLEANABLE,20W_28H_1D,ALUM	1	12
32.50	47.00	026-41366-063	FLTR,CLEANABLE,20W_28H_1D,ALUM	4	12
49.75	47.00	026-41366-063	FLTR,CLEANABLE,20W_28H_1D,ALUM	6	12
15.25	20.00	026-41366-064	FLTR,CLEANABLE,20W_29H_1D,ALUM	1	12
15.25	33.00	026-41366-065	FLTR,CLEANABLE,21W_21H_1D,ALUM	2	12
15.25	34.00	026-41366-065	FLTR,CLEANABLE,21W_21H_1D,ALUM	2	12
15.25	36.00	026-41366-066	FLTR,CLEANABLE,21W_22H_1D,ALUM	2	12
15.25	54.00	026-41366-066	FLTR,CLEANABLE,21W_22H_1D,ALUM	3	12
15.25	75.00	026-41366-066	FLTR,CLEANABLE,21W_22H_1D,ALUM	4	12
32.50	78.00	026-41366-066	FLTR,CLEANABLE,21W_22H_1D,ALUM	8	12
38.25	33.00	026-41366-066	FLTR,CLEANABLE,21W_22H_1D,ALUM	4	12
15.25	38.00	026-41366-067	FLTR,CLEANABLE,21W_23H_1D,ALUM	2	12
32.50	84.00	026-41366-067	FLTR,CLEANABLE,21W_23H_1D,ALUM	8	12
38.25	34.00	026-41366-067	FLTR,CLEANABLE,21W_23H_1D,ALUM	4	12
15.25	39.00	026-41366-068	FLTR,CLEANABLE,21W_24H_1D,ALUM	2	12
32.50	108.00	026-41366-068	FLTR,CLEANABLE,21W_24H_1D,ALUM	10	12
32.50	132.00	026-41366-068	FLTR,CLEANABLE,21W_24H_1D,ALUM	12	12
49.75	108.00	026-41366-068	FLTR,CLEANABLE,21W_24H_1D,ALUM	15	12
49.75	132.00	026-41366-068	FLTR,CLEANABLE,21W_24H_1D,ALUM	18	12
15.25	42.00	026-41366-069	FLTR,CLEANABLE,21W_25H_1D,ALUM	2	12
32.50	90.00	026-41366-069	FLTR,CLEANABLE,21W_25H_1D,ALUM	8	12
32.50	114.00	026-41366-069	FLTR,CLEANABLE,21W_25H_1D,ALUM	10	12
49.75	90.00	026-41366-069	FLTR,CLEANABLE,21W_25H_1D,ALUM	12	12
49.75	114.00	026-41366-069	FLTR,CLEANABLE,21W_25H_1D,ALUM	15	12
21.00	33.00	026-41366-070	FLTR,CLEANABLE,21W_26H_1D,ALUM	2	12
21.00	34.00	026-41366-070	FLTR,CLEANABLE,21W_26H_1D,ALUM	2	12
32.50	96.00	026-41366-070	FLTR,CLEANABLE,21W_26H_1D,ALUM	8	12
32.50	120.00	026-41366-070	FLTR,CLEANABLE,21W_26H_1D,ALUM	10	12
44.00	33.00	026-41366-070	FLTR,CLEANABLE,21W_26H_1D,ALUM	4	12
44.00	34.00	026-41366-070	FLTR,CLEANABLE,21W_26H_1D,ALUM	4	12
49.75	96.00	026-41366-070	FLTR,CLEANABLE,21W_26H_1D,ALUM	12	12
49.75	120.00	026-41366-070	FLTR,CLEANABLE,21W_26H_1D,ALUM	15	12
15.25	45.00	026-41366-071	FLTR,CLEANABLE,21W_27H_1D,ALUM	2	12
21.00	54.00	026-41366-071	FLTR,CLEANABLE,21W_27H_1D,ALUM	3	12
21.00	75.00	026-41366-071	FLTR,CLEANABLE,21W_27H_1D,ALUM	4	12
32.50	126.00	026-41366-071	FLTR,CLEANABLE,21W_27H_1D,ALUM	10	12
38.25	18.00	026-41366-071	FLTR,CLEANABLE,21W_27H_1D,ALUM	2	12
49.75	126.00	026-41366-071	FLTR,CLEANABLE,21W_27H_1D,ALUM	15	12

Continued on next page

<b>OA HOOD MOISTURE ELIMINATOR FILTERS (BY DAMPER SIZE) (CONTINUED)</b>					
<b>DAMPER HEIGHTH</b>	<b>DAMPER WIDTH</b>	<b>PART NUMBER</b>	<b>DESCRIPTION</b>	<b>QTY PER HOOD</b>	<b>QTY PER CARTON</b>
26.75	12.00	026-41366-072	FLTR,CLEANABLE,21W_28H_1D,ALUM	1	12
32.50	102.00	026-41366-072	FLTR,CLEANABLE,21W_28H_1D,ALUM	8	12
38.25	19.00	026-41366-072	FLTR,CLEANABLE,21W_28H_1D,ALUM	2	12
49.75	102.00	026-41366-072	FLTR,CLEANABLE,21W_28H_1D,ALUM	12	12
15.25	57.00	026-41366-074	FLTR,CLEANABLE,22W_22H_1D,ALUM	3	12
15.25	60.00	026-41366-075	FLTR,CLEANABLE,22W_23H_1D,ALUM	3	12
21.00	13.00	026-41366-075	FLTR,CLEANABLE,22W_23H_1D,ALUM	1	12
38.25	35.00	026-41366-075	FLTR,CLEANABLE,22W_23H_1D,ALUM	4	12
15.25	63.00	026-41366-076	FLTR,CLEANABLE,22W_24H_1D,ALUM	3	12
38.25	78.00	026-41366-076	FLTR,CLEANABLE,22W_24H_1D,ALUM	8	12
15.25	66.00	026-41366-077	FLTR,CLEANABLE,22W_25H_1D,ALUM	3	12
49.75	13.00	026-41366-077	FLTR,CLEANABLE,22W_25H_1D,ALUM	2	12
15.25	69.00	026-41366-078	FLTR,CLEANABLE,22W_26H_1D,ALUM	3	12
21.00	36.00	026-41366-078	FLTR,CLEANABLE,22W_26H_1D,ALUM	2	12
44.00	36.00	026-41366-078	FLTR,CLEANABLE,22W_26H_1D,ALUM	4	12
15.25	72.00	026-41366-079	FLTR,CLEANABLE,22W_27H_1D,ALUM	3	12
21.00	57.00	026-41366-079	FLTR,CLEANABLE,22W_27H_1D,ALUM	3	12
21.00	58.00	026-41366-079	FLTR,CLEANABLE,22W_27H_1D,ALUM	3	12
21.00	78.00	026-41366-079	FLTR,CLEANABLE,22W_27H_1D,ALUM	4	12
21.00	79.00	026-41366-079	FLTR,CLEANABLE,22W_27H_1D,ALUM	4	12
44.00	78.00	026-41366-079	FLTR,CLEANABLE,22W_27H_1D,ALUM	8	12
26.75	13.00	026-41366-080	FLTR,CLEANABLE,22W_28H_1D,ALUM	1	12
21.00	14.00	026-41366-081	FLTR,CLEANABLE,23W_23H_1D,ALUM	1	12
38.25	37.00	026-41366-081	FLTR,CLEANABLE,23W_23H_1D,ALUM	4	12
38.25	38.00	026-41366-081	FLTR,CLEANABLE,23W_23H_1D,ALUM	4	12
21.00	15.00	026-41366-082	FLTR,CLEANABLE,23W_24H_1D,ALUM	1	12
38.25	40.00	026-41366-082	FLTR,CLEANABLE,23W_24H_1D,ALUM	4	12
38.25	60.00	026-41366-082	FLTR,CLEANABLE,23W_24H_1D,ALUM	6	12
38.25	84.00	026-41366-082	FLTR,CLEANABLE,23W_24H_1D,ALUM	8	12
38.25	41.00	026-41366-083	FLTR,CLEANABLE,23W_25H_1D,ALUM	4	12
49.75	14.00	026-41366-083	FLTR,CLEANABLE,23W_25H_1D,ALUM	2	12
21.00	37.00	026-41366-084	FLTR,CLEANABLE,23W_26H_1D,ALUM	2	12
21.00	38.00	026-41366-084	FLTR,CLEANABLE,23W_26H_1D,ALUM	2	12
38.25	43.00	026-41366-084	FLTR,CLEANABLE,23W_26H_1D,ALUM	4	12
38.25	44.00	026-41366-084	FLTR,CLEANABLE,23W_26H_1D,ALUM	4	12
44.00	17.00	026-41366-084	FLTR,CLEANABLE,23W_26H_1D,ALUM	2	12
44.00	37.00	026-41366-084	FLTR,CLEANABLE,23W_26H_1D,ALUM	4	12
44.00	38.00	026-41366-084	FLTR,CLEANABLE,23W_26H_1D,ALUM	4	12
21.00	60.00	026-41366-085	FLTR,CLEANABLE,23W_27H_1D,ALUM	3	12
21.00	61.00	026-41366-085	FLTR,CLEANABLE,23W_27H_1D,ALUM	3	12
44.00	84.00	026-41366-085	FLTR,CLEANABLE,23W_27H_1D,ALUM	8	12
21.00	81.00	026-41366-086	FLTR,CLEANABLE,23W_28H_1D,ALUM	4	12
21.00	84.00	026-41366-086	FLTR,CLEANABLE,23W_28H_1D,ALUM	4	12

Continued on next page

<b>OA HOOD MOISTURE ELIMINATOR FILTERS (BY DAMPER SIZE) (CONTINUED)</b>					
<b>DAMPER HEIGHTH</b>	<b>DAMPER WIDTH</b>	<b>PART NUMBER</b>	<b>DESCRIPTION</b>	<b>QTY PER HOOD</b>	<b>QTY PER CARTON</b>
21.00	105.00	026-41366-086	FLTR,CLEANABLE,23W_28H_1D,ALUM	5	12
26.75	14.00	026-41366-086	FLTR,CLEANABLE,23W_28H_1D,ALUM	1	12
38.25	47.00	026-41366-086	FLTR,CLEANABLE,23W_28H_1D,ALUM	4	12
38.25	108.00	026-41366-088	FLTR,CLEANABLE,24W_24H_1D,ALUM	10	12
38.25	132.00	026-41366-088	FLTR,CLEANABLE,24W_24H_1D,ALUM	10	12
21.00	16.00	026-41366-089	FLTR,CLEANABLE,24W_25H_1D,ALUM	1	12
38.25	66.00	026-41366-089	FLTR,CLEANABLE,24W_25H_1D,ALUM	6	12
38.25	90.00	026-41366-089	FLTR,CLEANABLE,24W_25H_1D,ALUM	8	12
38.25	114.00	026-41366-089	FLTR,CLEANABLE,24W_25H_1D,ALUM	10	12
21.00	39.00	026-41366-090	FLTR,CLEANABLE,24W_26H_1D,ALUM	2	12
38.25	96.00	026-41366-090	FLTR,CLEANABLE,24W_26H_1D,ALUM	8	12
38.25	120.00	026-41366-090	FLTR,CLEANABLE,24W_26H_1D,ALUM	10	12
44.00	39.00	026-41366-090	FLTR,CLEANABLE,24W_26H_1D,ALUM	4	12
44.00	40.00	026-41366-090	FLTR,CLEANABLE,24W_26H_1D,ALUM	4	12
49.75	15.00	026-41366-090	FLTR,CLEANABLE,24W_26H_1D,ALUM	2	12
21.00	40.00	026-41366-091	FLTR,CLEANABLE,24W_27H_1D,ALUM	2	12
21.00	18.00	026-41366-091	FLTR,CLEANABLE,24W_27H_1D,ALUM	1	12
21.00	63.00	026-41366-091	FLTR,CLEANABLE,24W_27H_1D,ALUM	3	12
21.00	64.00	026-41366-091	FLTR,CLEANABLE,24W_27H_1D,ALUM	3	12
38.25	72.00	026-41366-091	FLTR,CLEANABLE,24W_27H_1D,ALUM	6	12
44.00	108.00	026-41366-091	FLTR,CLEANABLE,24W_27H_1D,ALUM	10	12
38.25	126.00	026-41366-092	FLTR,CLEANABLE,24W_28H_1D,ALUM	10	12
21.00	19.00	026-41366-092	FLTR,CLEANABLE,24W_28H_1D,ALUM	1	12
21.00	87.00	026-41366-092	FLTR,CLEANABLE,24W_28H_1D,ALUM	4	12
38.25	102.00	026-41366-092	FLTR,CLEANABLE,24W_28H_1D,ALUM	8	12
44.00	19.00	026-41366-092	FLTR,CLEANABLE,24W_28H_1D,ALUM	2	12
44.00	132.00	026-41366-092	FLTR,CLEANABLE,24W_28H_1D,ALUM	12	12
21.00	20.00	026-41366-093	FLTR,CLEANABLE,24W_29H_1D,ALUM	1	12
44.00	20.00	026-41366-093	FLTR,CLEANABLE,24W_29H_1D,ALUM	2	12
44.00	41.00	026-41366-095	FLTR,CLEANABLE,25W_26H_1D,ALUM	4	12
21.00	42.00	026-41366-096	FLTR,CLEANABLE,25W_27H_1D,ALUM	2	12
21.00	65.00	026-41366-096	FLTR,CLEANABLE,25W_27H_1D,ALUM	3	12
21.00	66.00	026-41366-096	FLTR,CLEANABLE,25W_27H_1D,ALUM	3	12
21.00	67.00	026-41366-096	FLTR,CLEANABLE,25W_27H_1D,ALUM	3	12
44.00	90.00	026-41366-096	FLTR,CLEANABLE,25W_27H_1D,ALUM	8	12
21.00	90.00	026-41366-097	FLTR,CLEANABLE,25W_28H_1D,ALUM	4	12
44.00	114.00	026-41366-097	FLTR,CLEANABLE,25W_28H_1D,ALUM	10	12
44.00	44.00	026-41366-099	FLTR,CLEANABLE,26W_26H_1D,ALUM	4	12
49.75	17.00	026-41366-099	FLTR,CLEANABLE,26W_26H_1D,ALUM	2	12
21.00	43.00	026-41366-100	FLTR,CLEANABLE,26W_27H_1D,ALUM	2	12
21.00	44.00	026-41366-100	FLTR,CLEANABLE,26W_27H_1D,ALUM	2	12
21.00	68.00	026-41366-100	FLTR,CLEANABLE,26W_27H_1D,ALUM	3	12
21.00	69.00	026-41366-100	FLTR,CLEANABLE,26W_27H_1D,ALUM	3	12

Continued on next page

<b>OA HOOD MOISTURE ELIMINATOR FILTERS (BY DAMPER SIZE) (CONTINUED)</b>					
<b>DAMPER HEIGHTH</b>	<b>DAMPER WIDTH</b>	<b>PART NUMBER</b>	<b>DESCRIPTION</b>	<b>QTY PER HOOD</b>	<b>QTY PER CARTON</b>
21.00	70.00	026-41366-100	FLTR,CLEANABLE,26W_27H_1D,ALUM	3	12
44.00	45.00	026-41366-100	FLTR,CLEANABLE,26W_27H_1D,ALUM	4	12
44.00	96.00	026-41366-100	FLTR,CLEANABLE,26W_27H_1D,ALUM	8	12
49.75	18.00	026-41366-100	FLTR,CLEANABLE,26W_27H_1D,ALUM	2	12
21.00	93.00	026-41366-101	FLTR,CLEANABLE,26W_28H_1D,ALUM	4	12
21.00	96.00	026-41366-101	FLTR,CLEANABLE,26W_28H_1D,ALUM	4	12
44.00	120.00	026-41366-101	FLTR,CLEANABLE,26W_28H_1D,ALUM	10	12
21.00	45.00	026-41366-103	FLTR,CLEANABLE,27W_27H_1D,ALUM	2	12
21.00	72.00	026-41366-103	FLTR,CLEANABLE,27W_27H_1D,ALUM	3	12
44.00	72.00	026-41366-103	FLTR,CLEANABLE,27W_27H_1D,ALUM	6	12
21.00	47.00	026-41366-104	FLTR,CLEANABLE,27W_28H_1D,ALUM	2	12
21.00	74.00	026-41366-104	FLTR,CLEANABLE,27W_28H_1D,ALUM	3	12
21.00	99.00	026-41366-104	FLTR,CLEANABLE,27W_28H_1D,ALUM	4	12
44.00	102.00	026-41366-104	FLTR,CLEANABLE,27W_28H_1D,ALUM	8	12
44.00	126.00	026-41366-104	FLTR,CLEANABLE,27W_28H_1D,ALUM	10	12
49.75	19.00	026-41366-104	FLTR,CLEANABLE,27W_28H_1D,ALUM	2	12
49.75	25.00	026-41366-104	FLTR,CLEANABLE,27W_28H_1D,ALUM	4	12
49.75	20.00	026-41366-105	FLTR,CLEANABLE,27W_29H_1D,ALUM	2	12

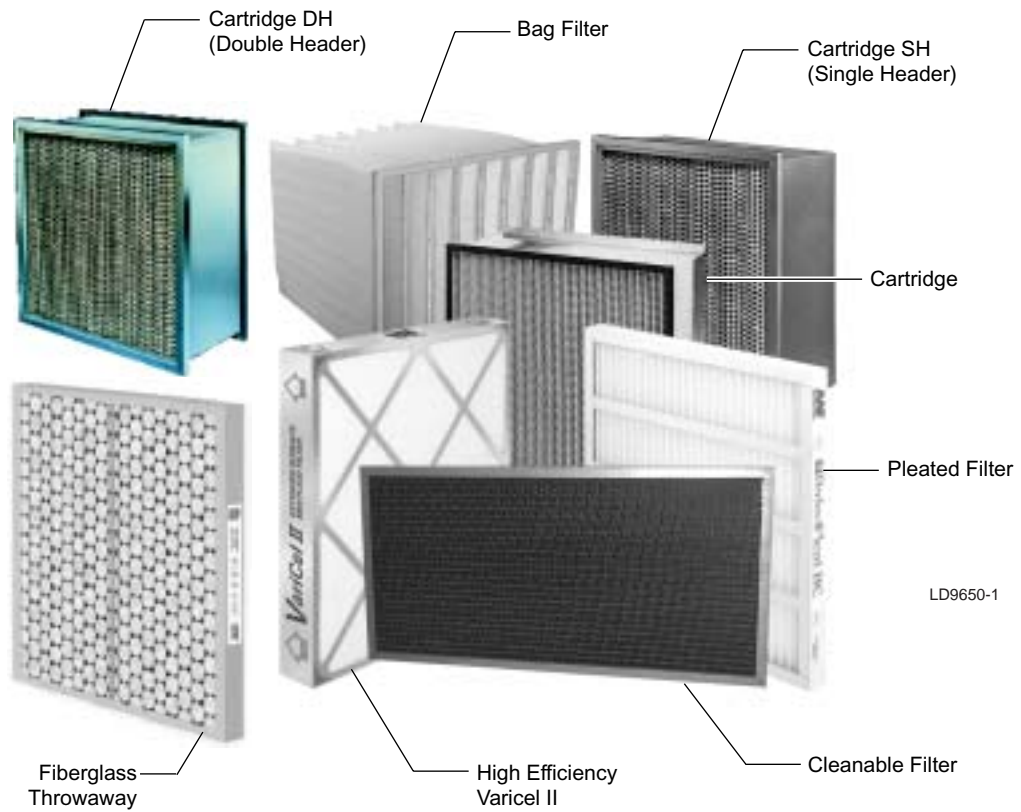

*If your unit has HEPA filters the filter frames, filter bulkheads and filter segment panels are factory sealed and must remain sealed for NO air bypass.*

**FIG. 14 - TYPICAL FILTERS**



**SINGLE LATCHES**

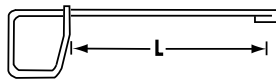

**KNOCK ON CONVERSION LATCH**

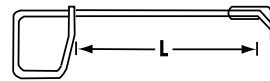

Note: Four (4) latches are recommended per frame

York Part Number	Vendor Part Number	Drawing Number	Latch Model Number	Length (L)
029-01048-005	391-007-004	80-1503507-4	L-10	5/32"
<b>Application:</b> Holds DriPak, VariCel or 1" filter in AAF Universal Holding Frame (UHF).				
029-01048-006	391-007-005	80-1503507-5	L-20	11/16"
<b>Application:</b> Holds 2" thick filter. Also holds DriPak or VariCel with a 1" prefilter in AAF UHF.				
029-01048-000	391-007-006	80-1503507-6	L-30	2"
<b>Application:</b> Holds DriPak or VariCel with a 2" prefilter in AAF UHF.				
029-01048-007	391-007-003	80-1503507-3	L-40	3-1/16"
<b>Application:</b> Holds two 2" or one 4" deep filter in AAF UHF.				
029-01048-008	391-007-007	80-1503507-7	L-50	3-15/16"
<b>Application:</b> Holds DriPak or VariCel with a 4" prefilter in AAF UHF.				
029-01048-012	391-006-004	80-1529262-4	L10 - Knockon	11/16"
<b>Application:</b> Holds DriPak, VariCel or 1" filter.				
029-01048-014	391-006-005	80-1529262-5	L20 - Knockon	1-5/8"
<b>Application:</b> Holds 2" thick filter. Also holds DriPak or VariCel with a 1" prefilter.				
029-01048-013	391-006-008	80-1529262-8	L40 - Knockon	3-5/8"
<b>Application:</b> Holds two 2" filters or one 4" deep filter.				
See HEPA filter section for HEPA filter latch part numbers and application.				

**DOUBLE LATCHES**

Prefilter can be changed without disturbing the final filter

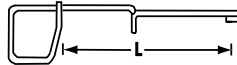

York Part Number	Vendor Part Number	Drawing Number	Latch Model Number	Length	
				L-1	L-2
029-01048-010	391-007-009	80-1503507-9	L-41	11/16"	3-1/16"
<b>Application:</b> Holds VariCel II or 4" AmAir with a 1" prefilter in AAF UHF					
029-01048-009	391-007-002	80-1503507-2	L-42	1-11/16"	3-1/16"
<b>Application:</b> Holds VariCel II or 4" AmAir with a 2" prefilter in AAF UHF					
029-01048-011	391-007-001	80-1503507-1	L-44	3-9/16"	3-1/16"
<b>Application:</b> Holds VariCel II or 4" AmAir with a 4" prefilter in AAF UHF					
Note: Four (4) latches are recommended per frame.					
General Information: Latches are made of .102" diameter zinc plated dipped spring steel.					

**KNOCK ON SPRING LATCH, VARICEL DH**



York Part Number	Vendor Part Number	Latch Model Number	Description	Service
026-36343-000	315-001-001	SL-12	SL-12" Spring Latch	Upstream or Downstream
<b>Application:</b> Holds a 12" deep double header VariCel in a FARR Universal Type 8 Holding Frame. (Can be used with AAF Universal Holding Frames or other manufacturers frames).				

**PREFILTER RETAINER CLIP, VARICEL DH**



York Part Number	Vendor Part Number	Latch Model Number	Description	Service
026-36339-001	315-003-002	VP-2	2" Clip	Upstream
026-36339-000	315-003-004	VP-4	4" Clip	Upstream
<b>Application:</b> Holds a 2" or 4" prefilter respectively, against the face of a DH VariCel. Can also be used on a SH VariCel installed in a DriPak Holding Frame.				
Prefilter Retaining Clips are made of zinc plated yellow chromated dipped steel				

**FIG. 15 - UNIVERSAL FRAME LATCH SELECTION**

VISUAL CONTROL FILTER CLAMPS FOR HEPA FILTERS				
York Part Number	Vendor Part Number	Drawing Number	Latch Model Number	Length (L)
029-22081-000	?	?	Latch, HEPA Single	11-1/2"
<b>Application:</b> Holds one Astrocel I 11.5" D filter along frame sides. (See Fig. 4-25, 4-26 and 4-27 for application)				
029-22082-000	?	?	Latch, HEPA Double	11-1/2"
<b>Application:</b> Holds one Astrocel I 11.5" D filter along frame middle. (See Fig. 4-25, 4-26 and 4-27 for application)				

11-1/2"  
ASTROCEL  
HCX

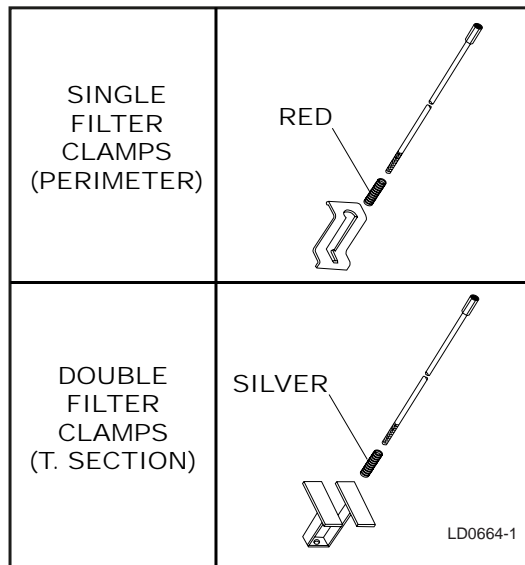
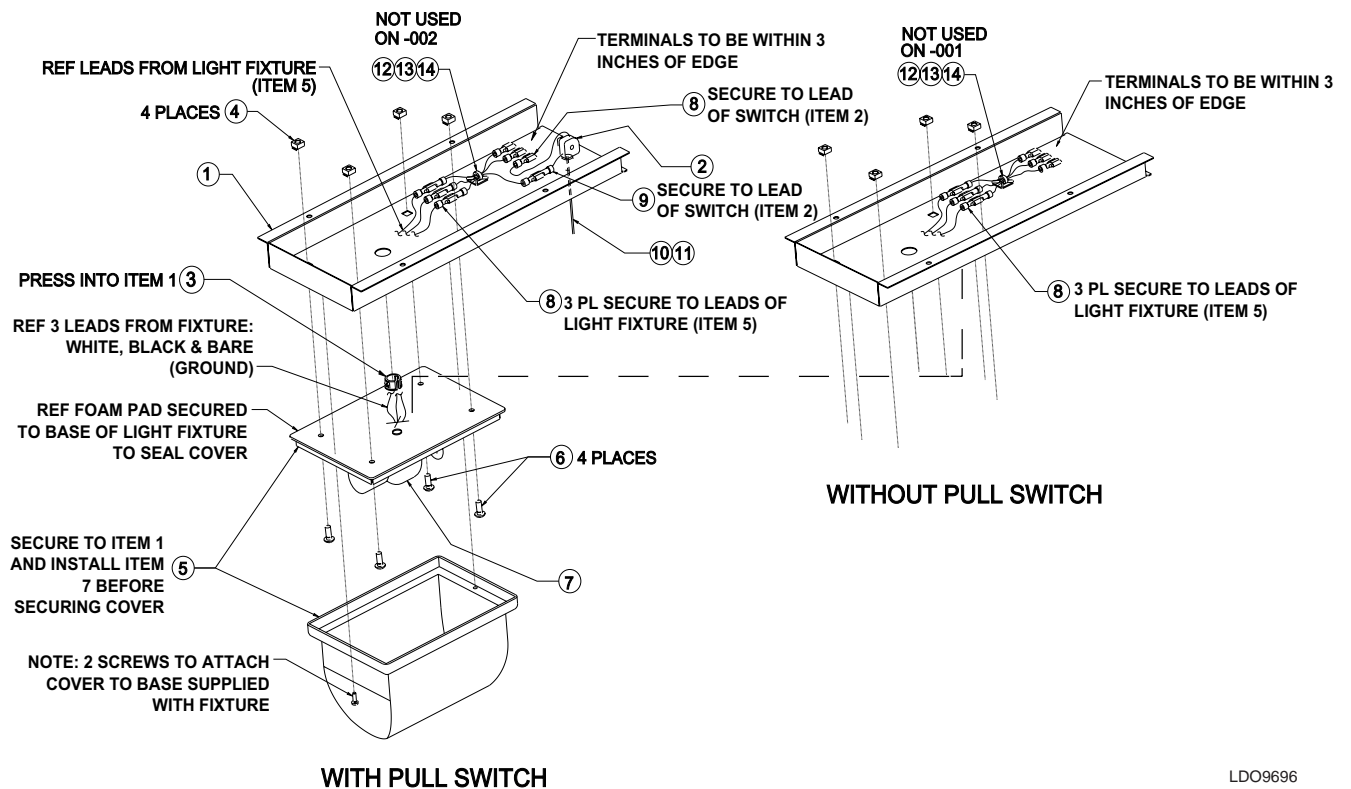

FIG. 16 - VISUAL CONTROL FILTER CLAMPS

### LIGHTING PARTS

LIGHT ASSEMBLIES	
PART NUMBER	DESCRIPTION
025-39019-002	Light assembly, w/switch, 11"lg.
025-39019-001	Light assembly, w/o switch, 11"lg.
025-39019-004	Light assembly, w/switch, 17"lg.
025-39019-003	Light assembly, w/o switch, 17"lg.
025-39019-006	Light assembly, w/switch, 28"lg.
025-39019-005	Light assembly, w/o switch, 28"lg.

LIGHT ASSEMBLY BREAKDOWN		
ITEM NO.	PART NUMBER	DESCRIPTION
1	—	LIGHT BRACKET/WIREWAY
2	025-39014-001	PULL SWITCH
3	—	GROMMET
4	—	1/4-20 PANEL NUT
5	025-39013-001	LIGHT FIXTURE W/ COVER
6	—	1/4-20 X 3/4 LG PAN HD SCREW
7	—	LIGHT BULB
8	—	FEMALE INSULATED TERMINAL
9	—	MALE INSULATED TERMINAL
10	—	CHAIN CONNECTOR, #6, NICKEL PLATED BRASS
11	—	BALL CHAIN, #6, NICKEL PLATED STEEL
12	—	WIRING HARNESS
13	—	SELF ADHESIVE CABLE MOUNT
14	—	CABLE TY-WRAP



LDO9696

FIG. 17 - EXPLODED VIEW OF LIGHT ASSEMBLIES

(LIGHT FIXTURE & BULB)

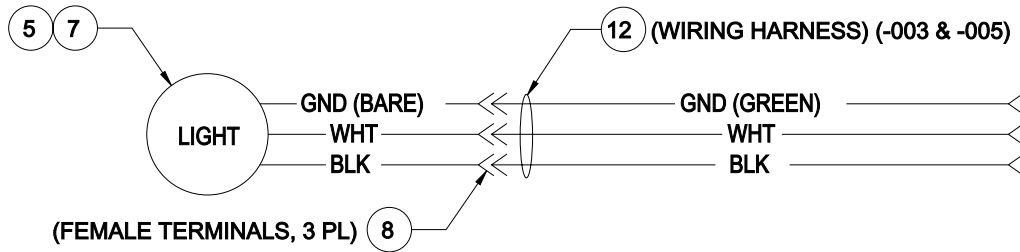

WITHOUT PULL SWITCH

(LIGHT FIXTURE & BULB)

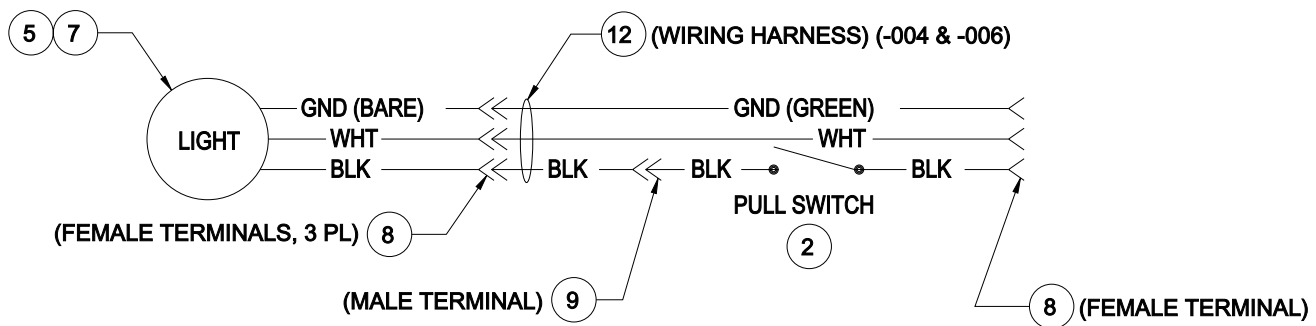

WITH PULL SWITCH

FIG. 18 - LIGHTING SCHEMATIC

LDO9697

ELECTRICAL REPLACEMENT PARTS	
<b>J-BOX ONLY ASSEMBLY</b>	
025-39009-001	COVER, 1-GANG, DRY TYPE, BLANK.
<b>RECEPTACLE ONLY ASSEMBLY</b>	
025-39007-001	COVER, 1-GANG, DRY TYPE, 1-GFI
<b>LIGHT SWITCH ONLY ASSEMBLY</b>	
025-39007-001	COVER, 1-GANG, DRY TYPE, 1-GFI
025-39003-001	SWITCH, 20 AMP ROCKER, IVORY
<b>LIGHT SWITCH / RECEPTACLE ASSEMBLY</b>	
025-39007-002	COVER, 2-GANG, DRY TYPE, 2-GFI, RED DOT DRYTITE
025-39003-001	SWITCH, 20 AMP ROCKER, IVORY
025-39004-001	RECEPTACLE, 20 AMP, GFI, IVORY
<b>1 HOUR TIMER ONLY ASSEMBLY</b>	
025-39008-001	COVER, 1-GANG, RED DOT, CODE KEEPER, 1-GFI
025-39012-001	TIMER, SWITCH, 1 HOUR W/ HOLD, 20 AMPS @ 125 VAC, IVORY DECORATOR
<b>1 HOUR TIMER / RECEPTACLE ASSEMBLY</b>	
025-39008-002	COVER, 2-GANG, 2-GFI, RED DOT, CODE KEEPER
025-39004-001	RECEPTACLE, 20 AMP, GFI, IVORY (CONVENIENCE OUTLET)
025-39012-001	TIMER, SWITCH, 1 HOUR W/ HOLD, 20 AMPS @ 125 VAC, IVORY DECORATOR

WIRING-HARNESSES LIGHT ASSEMBLY - PANEL TO WIRE TRACK		
PART-NUMBER	DESCRIPTION	DIM A INCHES
025-39020-001	Harness, Panel to Wire Track, #12 ga W/Conduit, 1' LG.	12
025-39020-002	Harness, Panel to Wire Track, #12 ga W/Conduit, 2' LG.	24
025-39020-003	Harness, Panel to Wire Track, #12 ga W/Conduit, 3' LG.	36
025-39020-004	Harness, Panel to Wire Track, #12 ga W/Conduit, 4' LG.	48
025-39020-005	Harness, Panel to Wire Track, #12 ga W/Conduit, 5' LG.	60
025-39020-006	Harness, Panel to Wire Track, #12 ga W/Conduit, 6' LG.	72
025-39020-007	Harness, Panel to Wire Track, #12 ga W/Conduit, 7' LG.	84
025-39020-008	Harness, Panel to Wire Track, #12 ga W/Conduit, 8' LG.	96
025-39020-009	Harness, Panel to Wire Track, #12 ga W/Conduit, 9' LG.	108
025-39020-010	Harness, Panel to Wire Track, #12 ga W/Conduit, 10' LG.	120

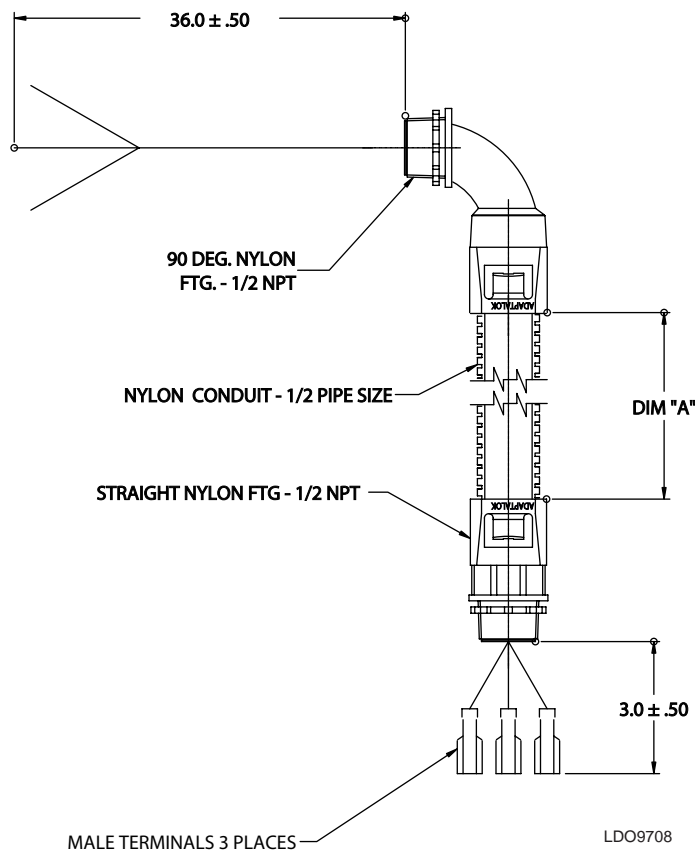

FIG. 19 - PANEL TO WIRETRACK

WIRING-HARNESSES LIGHT ASSEMBLY - WIRE TRACK		
PART-NUMBER	DESCRIPTION	DIM A INCHES
025-39022-001	Harness Wiretrack, 12 ga, 3 wire, 1' LG.	12
025-39022-002	Harness Wiretrack, 12 ga, 3 wire, 2' LG.	24
025-39022-003	Harness Wiretrack, 12 ga, 3 wire, 3' LG.	36
025-39022-004	Harness Wiretrack, 12 ga, 3 wire, 4' LG.	48
025-39022-005	Harness Wiretrack, 12 ga, 3 wire, 5' LG.	60
025-39022-006	Harness Wiretrack, 12 ga, 3 wire, 6' LG.	72
025-39022-007	Harness Wiretrack, 12 ga, 3 wire, 7' LG.	84
025-39022-008	Harness Wiretrack, 12 ga, 3 wire, 8' LG.	96
025-39022-009	Harness Wiretrack, 12 ga, 3 wire, 9' LG.	108
025-39022-010	Harness Wiretrack, 12 ga, 3 wire, 10' LG.	120
025-39022-011	Harness Wiretrack, 12 ga, 3 wire, 11' LG.	132
025-39022-012	Harness Wiretrack, 12 ga, 3 wire, 12' LG.	144
025-39022-013	Harness Wiretrack, 12 ga, 3 wire, 13' LG.	156
025-39022-014	Harness Wiretrack, 12 ga, 3 wire, 14' LG.	168
025-39022-015	Harness Wiretrack, 12 ga, 3 wire, 15' LG.	180
025-39022-016	Harness Wiretrack, 12 ga, 3 wire, 16' LG.	192
025-39022-017	Harness Wiretrack, 12 ga, 3 wire, 17' LG.	204
025-39022-018	Harness Wiretrack, 12 ga, 3 wire, 18' LG.	216
025-39022-019	Harness Wiretrack, 12 ga, 3 wire, 19' LG.	228
025-39022-020	Harness Wiretrack, 12 ga, 3 wire, 20' LG.	240
386-02271-001	Harness, Wiretrack Tee Kit	N/A

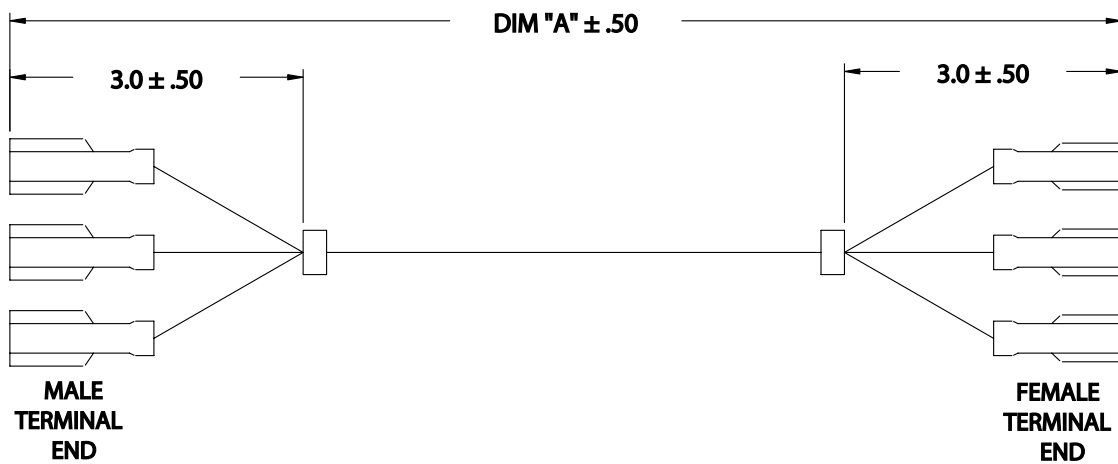

FIG. 20 - HARNESS-WIRETRACK

LDO9709

<b>WIRING-HARNESSES LIGHT ASSEMBLY - TIER TO TIER</b>	
<b>PART-NUMBER</b>	<b>DESCRIPTION</b>
386-01160-001	Harness, Tier to Tier, #12 ga W/Conduit, 3' LG.
386-01160-001	Harness, Tier to Tier, #12 ga W/Conduit, 3' LG.
386-01160-002	Harness, Tier to Tier, #12 ga W/Conduit, 4' LG.
386-01160-002	Harness, Tier to Tier, #12 ga W/Conduit, 4' LG.
386-01160-002	Harness, Tier to Tier, #12 ga W/Conduit, 4' LG.
386-01160-002	Harness, Tier to Tier, #12 ga W/Conduit, 4' LG.
386-01160-003	Harness, Tier to Tier, #12 ga W/Conduit, 5' LG.
386-01160-003	Harness, Tier to Tier, #12 ga W/Conduit, 5' LG.
386-01160-003	Harness, Tier to Tier, #12 ga W/Conduit, 5' LG.
386-01160-003	Harness, Tier to Tier, #12 ga W/Conduit, 5' LG.
386-01160-004	Harness, Tier to Tier, #12 ga W/Conduit, 6' LG.
386-01160-004	Harness, Tier to Tier, #12 ga W/Conduit, 6' LG.
386-01160-004	Harness, Tier to Tier, #12 ga W/Conduit, 6' LG.
386-01160-004	Harness, Tier to Tier, #12 ga W/Conduit, 6' LG.
386-01160-005	Harness, Tier to Tier, #12 ga W/Conduit, 7' LG.
386-01160-005	Harness, Tier to Tier, #12 ga W/Conduit, 7' LG.
386-01160-005	Harness, Tier to Tier, #12 ga W/Conduit, 7' LG.
386-01160-005	Harness, Tier to Tier, #12 ga W/Conduit, 7' LG.
386-01160-006	Harness, Tier to Tier, #12 ga W/Conduit, 8' LG.
386-01160-006	Harness, Tier to Tier, #12 ga W/Conduit, 8' LG.
386-01160-007	Harness, Tier to Tier, #12 ga W/Conduit, 9' LG.
386-01160-007	Harness, Tier to Tier, #12 ga W/Conduit, 9' LG.
386-01160-008	Harness, Tier to Tier, #12 ga W/Conduit, 10' LG.
386-01160-008	Harness, Tier to Tier, #12 ga W/Conduit, 10' LG.
386-01160-009	Harness, Tier to Tier, #12 ga W/Conduit, 11' LG.
386-01160-009	Harness, Tier to Tier, #12 ga W/Conduit, 11' LG.
386-01160-010	Harness, Tier to Tier, #12 ga W/Conduit, 12' LG.
386-02271-001	Harness, Wiretrack Tee Kit

<b>SWITCH/RECEPTACLE</b>	
<b>PART NUMBER</b>	<b>DESCRIPTION</b>
386-01156-001	Light Switch / Receptacle assembly
386-01157-001	Light Switch Only assembly
386-01158-001	Receptacle Only assembly
386-01159-001	J-box Only assembly
386-02206-001	1 Hour Timer Only assembly
386-02207-001	1 Hour Timer / Receptacle assembly

TRANSFORMER PANEL	
PART NUMBER	DESCRIPTION
025-39105-001	2KVA Transformer Panel, 200-208v to 120vac
025-39105-003	2KVA Transformer Panel, 230v to 120vac
025-39105-005	2KVA Transformer Panel, 460v to 120vac
025-39105-007	2KVA Transformer Panel, 575v to 120vac

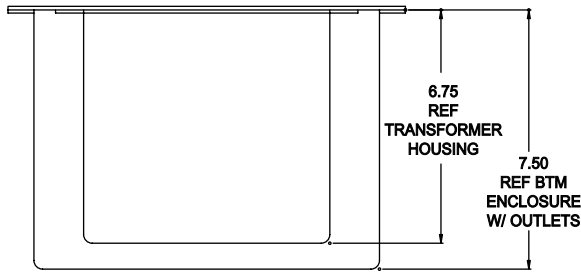

**TOP VIEW**

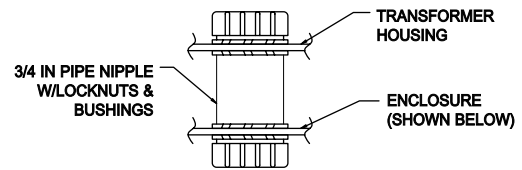

**DETAIL "A"**

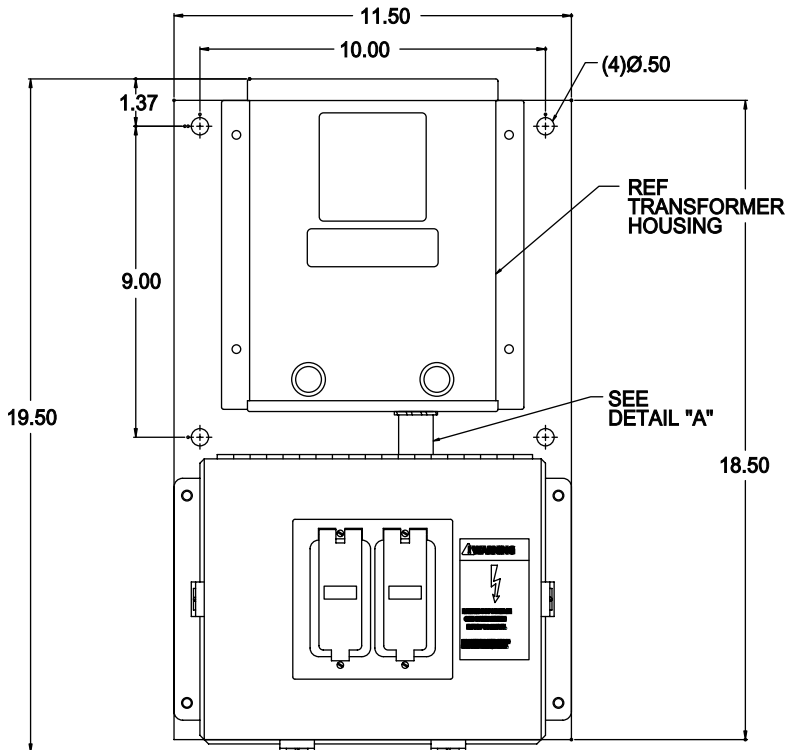

**COMPLETE ASSEMBLY  
(DIMS IN INCHES)**

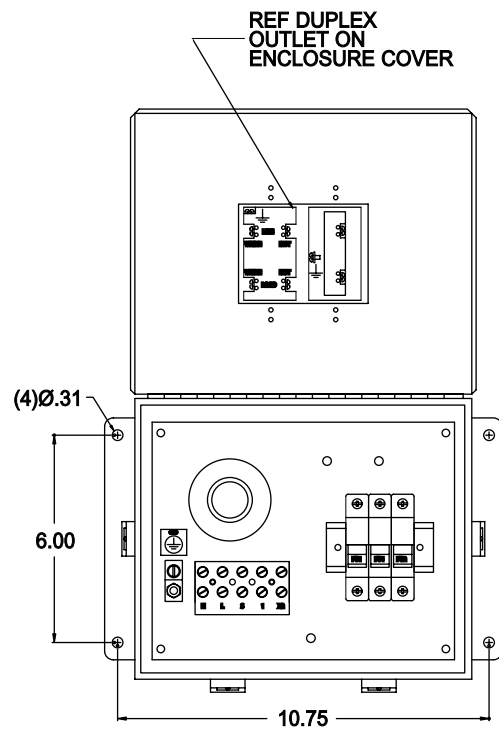

**ENCLOSURE DETAIL SHOWN OPEN  
(DIMS IN INCHES)**

LDO9710

FIG. 21 - TRANSFORMER PANEL DIMENSIONS



FILTER GAGE KITS		
PART NUMBER	QTY	DESCRIPTION
386-01161-001	1	FILTER GAGE ASSEMBLY - SINGLE FILTER BANK KIT 1 Ea. Gage, Differential Pressure, Minihelic II, 0-3"W.C * 4 Ft. Tubing, Fire Rated Black Plastic, 1/4" O.D., .040" Wall ** 1 Ea. Eyelets, Flat Flange, .187 O.D., .503 Lg., .312 Flange, Brass 1 Ea. Push Retainer for Non-Threaded Shaft, 3/16" 4 ea. Clamp, Tube, 1/4" O.D., Aluminum
386-01161-001	1	FILTER GAGE ASSEMBLY - TOTAL FILTER BANK KIT 1 Ea. Gage, Differential Pressure, Minihelic II, 0-3"W.C * 4 Ft. Tubing, Fire Rated Black Plastic, 1/4" O.D., .040" Wall ** 1 Ea. Eyelets, Flat Flange, .187 O.D., .503 Lg., .312 Flange, Brass 1 Ea. Push Retainer for Non-Threaded Shaft, 3/16" 4 ea. Clamp, Tube, 1/4" O.D., Aluminum
386-01161-002	1	FILTER GAGE ASSEMBLY - COMBINED FILTERS KIT 2 Ea. Gage, Differential Pressure, Minihelic II, 0-3"W.C * 6 Ft. Tubing, Fire Rated Black Plastic, 1/4" O.D., .040" Wall ** 2 Ea. Eyelets, Flat Flange, .187 O.D., .503 Lg., .312 Flange, Brass 2 Ea. Push Retainer for Non-Threaded Shaft, 3/16" 6 Ea. Clamp, Tube, 1/4" O.D., Aluminum 1 Ea. Tee, Brass, Barbed, 1/4"
086-23690-001	1	Plate, Liner Cover, Minihelic II, 18 Ga., Stainless Steel w/ 386-01161-001
086-23690-001	2	Plate, Liner Cover, Minihelic II, 18 Ga., Stainless Steel w/ 386-01161-002



FIG. 23 - TYPICAL FILTER GAUGE

\* 1/4" tubing may be ordered separately, P/N 025-11958-000

\*\* Sensor Probes (.187 eyelets) may be ordered separately. P/N 025-39050-000.

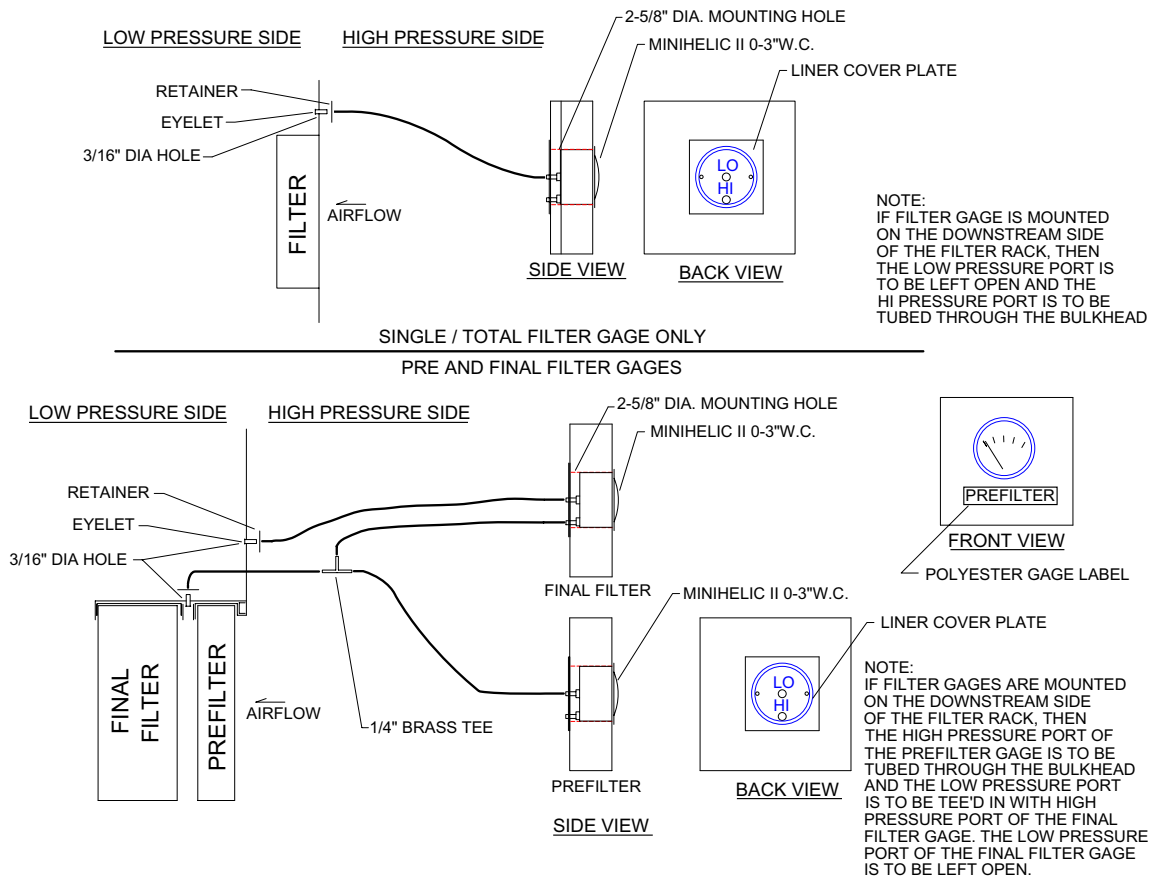
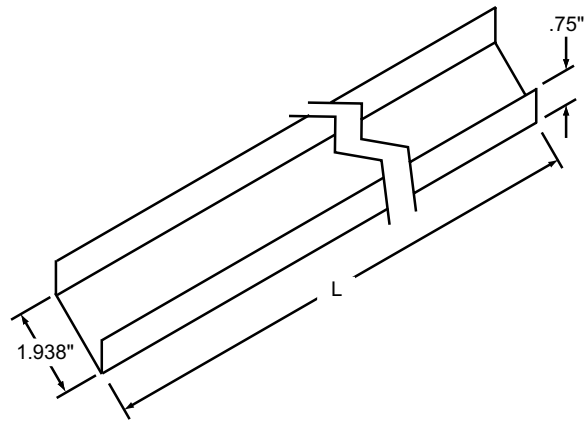

FIG. 22 - FILTER GAUGE DIAGRAMS

LDO9711



Notes:

1. Select the C-Channel that is nearest to the size of your opening and cut to fit.

2. Available lengths (L) for stiffeners:

PART NUMBER	LENGTH (L)
087-40048-050	47.938"
087-40072-050	71.938"
087-40127-050	126.938"

FIG. 24 - C-CHANNEL TRIM FOR:  
FIELD CUT OPENINGS  
FIELD MODIFICATION TO ADD DOORS

PART NUMBER	DESCRIPTION
TAC2401012000	STEEL SECURITY CHAIN
TAC2401013000	BOLT SNAPS
TAC2401014000	STEEL STAPLE PLATE
TAC2401015000	COLD SHUTS
TAC3303006000	FENDER WASHER, .313"
013-02978-010	PERMA GUM/BUTYL TAPE, 0.5"W X .13" THK

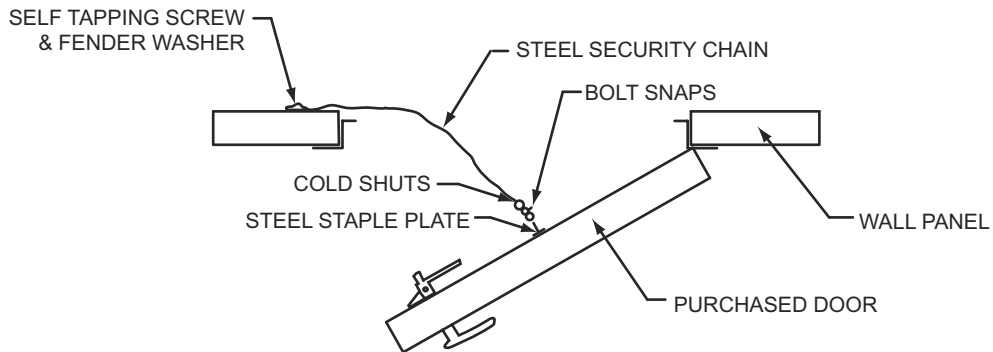

FIG. 25 - DOOR CHAIN ASSEMBLY

PART NUMBER INDEX			
PART NUMBER	DESCRIPTION	Table	PAGE
010-01017-010	Caulk, Sikaflex, 221 SF, Sika Corp or Equal	Gasket/Caulk/Adhesive for Solution Units	11
010-02917-000	Ins Therm 1/8 x 1-1/2 x 50 Lg, Ind. Rolls C3-241-DC 221 White Ethafoam, w/psa, Std R749 DTD 10/8/90 Marriage Tape	Gasket/Caulk/Adhesive for Solution Units	11
013-02966-011	Caulk, Manus-bond,75-am, Manus Products, or Equal	Gasket/Caulk/Adhesive for Solution Units	11
013-02976-010	Tape, Butyl, 0.75W x .19THK, TC-49 XI 121, Manus Products, or Equal	Gasket/Caulk/Adhesive for Solution Units	11
013-02977-010	Tape, Butyl, 1.5W x .13THK, TC-49 XI 121, Manus Products, or Equal	Gasket/Caulk/Adhesive for Solution Units	11
013-02978-010	Tape, Butyl, 0.5W x .13THK, TC-49 XI 121, Manus Products, or Equal	Gasket/Caulk/Adhesive for Solution Units	11
013-02978-010	Tape, Butyl, 0.5W x .13THK, TC-49 XI 121, Manus Products, or Equal	Door Chain Assembly	66
013-02979-010	Tape, Butyl, 0.5W x .25THK, TC-49 XI 121, Manus Products, or Equal	Gasket/Caulk/Adhesive for Solution Units	11
013-03317-010	Caulk, Solvent Free, Pace Gray or Equal, Sikaflex 221 SF or Manus-bond 75-AM	Gasket/Caulk/Adhesive for Solution Units	11
013-22013-010	Adhesive, Super Fast,#74, 3M or Equal	Gasket/Caulk/Adhesive for Solution Units	11
021- 02782- 000	Scr Hex Cap 5/16-18 X 1-1/4, 1-1/4 Lg Stl Zinc Pltd	Fasteners for Solution Units	9
021-00331-000	Bolt, Lag Hex 3/8 X2-1/2 Zinc Plated	Fasteners for Solution Units	9
021-01154-000	Wash, Lk Th Int 5/16 Hvy,zinc Pltd., Std. C-76	Fasteners for Solution Units	9
021-01155-000	Wash, Lk Th Int 3/8 Std C-76	Fans And Motors, Securing	32
021-01155-000	Wash, Lk Th Int 3/8 Std C-76	Fasteners for Solution Units	9
021-01155-000	Washer, Lock, Int, 3/8	Shell Components	35
021-01155-000	Wash Lk Th Int 3/8 Std C-76	Splice & Split Raceway Kits	37
021-01155-000	Wash, Lk Th Int 3/8 Std C-76	Thrust Restraint Kits	18
021-01163-000	Wash, Lk Th Int 1/2 Hvy Stl Zinc Pltd., Std. C-76	Fans And Motors, Securing	32
021-01163-000	Wash, Lk Th Int 1/2 Hvy Stl Zinc Pltd., Std. C-76	Fasteners for Solution Units	9
021-01163-000	Lockwasher, 1/2"	Shell Components	35
021-01163-000	Wash, Lk Th Int 1/2 Hvy Stl Zinc Pltd., Std. C-76	Splice & Split Baserail Kits	36
021-01163-000	Wash, Lk Th Int 1/2 Hvy Stl Zinc Pltd., Std. C-76	Splice & Split Baserail Kits	36
021-01163-000	Wash, Lk Th Int 1/2 Hvy Stl Zinc Pltd., Std. C-76	Splice & Split Baserail Kits	36
021-01163-000	Wash, Lk Th Int 1/2 Hvy Stl Zinc Pltd., Std. C-76	Splice & Split Baserail Kits	36
021-01163-000	Wash, Lk Th Int 1/2 Hvy Stl Zinc Pltd., Std. C-76	Splice & Split Baserail Kits	36
021-01168-000	Wash Lk Th Int 5/8 Stl Zinc Pltd., Std. C-76	Fasteners for Solution Units	9
021-01248-000	Washer Plain 5/16 ID X 3/4 OD X 0.065 Nom Thk : Steel	Fans And Motors, Securing	32
021-01248-000	Washer Plain 5/16 ID X 3/4 OD X 0.065 Nom Thk : Steel	Fasteners for Solution Units	9
021-01267-000	Wash Flt 7/16 ID X 1 OD X 0.083 Thk Stl Zinc Pltd.	Fans And Motors, Securing	32
021-01267-000	Wash Flt 7/16 ID X 1 OD X 0.083 Thk Stl Zinc Pltd.	Fasteners for Solution Units	9
021-01267-000	Wash Flt 7/16 ID X 1 OD X 0.083 Thk Stl Zinc Pltd.	Thrust Restraint Kits	18
021-01288-000	Wash Flt 11/16 ID X 1-3/4 OD 0.134 Thk Stl Zinc Pltd., Std. C-48	Fasteners for Solution Units	9
021-01481-000	Scr, Cap Hex 3/8 - 16 unc - 2a X 1.0, Zinc Plated	Fasteners for Solution Units	9
021-01481-000	Bolt, 3/8"-16	Shell Components	35
021-01481-000	Scr, Cap Hex 3/8 - 16 unc - 2a X 1.0, Zinc Plated	Thrust Restraint Kits	18
021-01499-000	Screw, Cap Hex 3/8 - 16 unc - 2a X 1.5, Zinc Plated	Fans And Motors, Securing	32
021-01499-000	Screw, Cap Hex 3/8 - 16 unc - 2a X 1.5, Zinc Plated	Fasteners for Solution Units	9
021-02523-000	Nut, Hex 5/16 - 18 unc - 2b Stl Zinc Pltd	Fasteners for Solution Units	9
021-02794-000	Scr Hex 5/8-11unc-2a X 2.00" Sae J429	Fasteners for Solution Units	9
021-02860-000	Nut, Hex 1/2-13 Hvy 7/8 Stl Zinc Pltd., Std. C-85	Fans And Motors, Securing	32
021-02860-000	Nut, Hex 1/2-13 Hvy 7/8 Stl Zinc Pltd., Std. C-85	Fasteners for Solution Units	9
021-02860-000	Nut, 1/2"-13	Shell Components	35

PART NUMBER INDEX			
PART NUMBER	DESCRIPTION	Table	PAGE
021-02860-000	Nut, Hex 1/2-13 Hvy 7/8 Stl Zinc Pltd., Std. C-85	Splice & Split Baserail Kits	36
021-02860-000	Nut, Hex 1/2-13 Hvy 7/8 Stl Zinc Pltd., Std. C-85	Splice & Split Baserail Kits	36
021-02860-000	Nut, Hex 1/2-13 Hvy 7/8 Stl Zinc Pltd., Std. C-85	Splice & Split Baserail Kits	36
021-02860-000	Nut, Hex 1/2-13 Hvy 7/8 Stl Zinc Pltd., Std. C-85	Splice & Split Baserail Kits	36
021-02860-000	Nut, Hex 1/2-13 Hvy 7/8 Stl Zinc Pltd., Std. C-85	Splice & Split Baserail Kits	36
021-02862-000	Nut Hex 5/8-11 Hvy Stl Zinc Pltd., Std. C-85	Fasteners for Solution Units	9
021-03749-000	Scr Mach Rd Ph 1/4-20unc-2a X 1-1/4 Lg Stl Zinc Pltd.	Fans And Motors, Securing	32
021-03749-000	Scr Mach Rd Ph 1/4-20unc-2a X 1-1/4 Lg Stl Zinc Pltd.	Fasteners for Solution Units	9
021-05146-000	Wash, Flt 9/16 ID X 1-3/8 OD .109 Thk Stl Zinc Plated	Fans And Motors, Securing	32
021-05146-000	Wash, Flt 9/16 ID X 1-3/8 OD .109 Thk Stl Zinc Plated	Fasteners for Solution Units	9
021-08388-000	Scr, Hex 1/2-13unc-2a X 1" Stl Zinc Pltd, Sae J429	Fasteners for Solution Units	9
021-08388-000	Bolt, 1/2"-13	Shell Components	35
021-08394-000	Scr, Hex Cap 5/16-18 X 3/4 Lg Stl Zinc Pltd	Fasteners for Solution Units	9
021-08395-000	Scr, Cap Hex 3/8 - 16 unc - 2a X 0.75, Stl Zinc Pltd	Fasteners for Solution Units	9
021-09983-000	Wash, Flt 3/8 ID X 7/8 OD 0.083 Thk Stl Zinc Plated,ansi B27.2, Std C-48	Fasteners for Solution Units	9
021-10186-000	Lock Washer Spg Helical 1/4, Steel	Fasteners for Solution Units	9
021-11645-000	Nut, Ret 3/8-16.162/.210 .162 - .210 Panel Range, Std. C-77	Fasteners for Solution Units	9
021-12656-000	Nut Hex 3/4-10 Hvy Stl Zinc Ctd Asa B18	Fans And Motors, Securing	32
021-12656-000	Nut Hex 3/4-10 Hvy Stl Zinc Ctd Asa B18	Fasteners for Solution Units	9
021-12917-000	Scr, Tap Ty B Hex 5/16 X 3/4 5/16 Dia X 3/4 Lg Stl Cd Pl	Fasteners for Solution Units	9
021-13291-000	Nut Ret 1/4-20 0125-0.156 Panel Range, Std. C-77	Fasteners for Solution Units	9
021-13734-000	Scr, Tap Ty F Pan 1/4 X 1/2 Lg Stl Zinc Pltd	Fasteners for Solution Units	9
021-13830-000	Scr Hex Cap 3/4-10 X 2-1/2, Stl Zinc Pltd	Fans And Motors, Securing	32
021-13830-000	Scr Hex Cap 3/4-10 X 2-1/2, Stl Zinc Pltd	Fasteners for Solution Units	9
021-13863-000	Scr, Tap Self Drill 10-24 X 1/2 Hd #10-24 X 1/2 Lg Style 3 Shakeproof # 621-100880-00-0251t, stl, zinc Pltd	Fasteners for Solution Units	9
021-13911-000	Scr, Tap Type B Hex 3/8 X 3/4 Stl Zinc Pltd.	Fasteners for Solution Units	9
021-15802-000	Wash Flt 13/16 ID X 1-3/4 OD X 0.134 Thk Stl Zinc	Fans And Motors, Securing	32
021-15802-000	Wash Flt 13/16 ID X 1-3/4 OD X 0.134 Thk Stl Zinc	Fasteners for Solution Units	9
021-16151-000	Lock Washer Spg Helical 1/4, Steel	Fans And Motors, Securing	32
021-16151-000	Lock Washer Spg Helical 1/4, Steel	Fasteners for Solution Units	9
021-17212-000	Screw, hex Hd Cap, 1/4-20x1-1/2", Full Thread, Zinc Plated	Fasteners for Solution Units	9
021-17711-000	Rivet, Pop, 1/8"x1/4" Grip	Fasteners for Solution Units	9
021-17717-000	Nut, Hex Lk 3/8-16, Zinc Plated	Fasteners for Solution Units	9
021-17718-000	Nut Hex 1/4 - 20 unc - 2b	Fans And Motors, Securing	32
021-17718-000	Nut Hex 1/4 - 20 unc - 2b	Fasteners for Solution Units	9
021-17722-000	Scr, Tap Ty A Ph 14-10 1/4 X3/4 Pan Head, Phillips (#1), Type A, Zinc Plated	Fasteners for Solution Units	9
021-17722-000	Screw, Pan Head, 1/4" X 3/4"	Shell Components	35
021-17728-000	Scr Hex 1/2-13unc-2a X 1.75" Sae J429	Fans And Motors, Securing	32
021-17728-000	Scr Hex 1/2-13unc-2a X 1.75", Stl Zinc Pltd, Sae J429	Fasteners for Solution Units	9
021-17728-000	Bolt, 1/2"-13	Shell Components	35
021-17728-000	Scr Hex 1/2-13unc-2a X 1.75" Sae J429	Splice & Split Baserail Kits	36
021-17728-000	Scr Hex 1/2-13unc-2a X 1.75" Sae J429	Splice & Split Baserail Kits	36
021-17728-000	Scr Hex 1/2-13unc-2a X 1.75" Sae J429	Splice & Split Baserail Kits	36
021-17728-000	Scr Hex 1/2-13unc-2a X 1.75" Sae J429	Splice & Split Baserail Kits	36
021-17728-000	Scr Hex 1/2-13unc-2a X 1.75" Sae J429	Splice & Split Baserail Kits	36
021-17728-000	Scr Hex 1/2-13unc-2a X 1.75" Sae J429	Splice & Split Baserail Kits	36
021-19305-016	Screw, 3/8"-16	Shell Components	35

PART NUMBER INDEX			
PART NUMBER	DESCRIPTION	Table	PAGE
021-19305-016	Screw, Cap Hex 3/8 - 16 unc - 2a X 1.0, Zinc Plated Grade 5	Splice & Split Raceway Kits	37
021-19307-000	Nut Hex Lk 3/8-16 Zinc Plated	Fans And Motors, Securing	32
021-19307-000	Hex Nut, Lock, 3/8"-16	Shell Components	35
021-19307-000	Nut, Hex Lk 3/8-16 Zinc Plated	Thrust Restraint Kits	18
021-19307-010	Nut, Hex 3/8-16, Zinc Plated	Fasteners for Solution Units	9
021-19515-000	Screw, Self-drilling: 1/4 - 14 Un X 3/4 Lg, Stl Zinc Plated	Fasteners for Solution Units	10
021-19515-000	Screw, Self-Drilling: 1/4 - 14 Un X 3/4 Lg, Zinc Plated	Thrust Restraint Kits	18
021-19556-000	Scr, Hex 1/2-13unc-2a X 9" Stl Zinc Pltd, Sae J429, All Thread, Or Equal	Fasteners for Solution Units	10
021-19558-000	Block, Motor Base, 1/2-13 & 3/8-16 Thru Holes	Fasteners for Solution Units	10
021-19559-000	Scr, Cap Hex 3/8 - 16 unc - 2a X 5.0, Stl Zinc Plated	Fasteners for Solution Units	10
021-19560-000	Scr, 1/4-14x1, phil Pan Self Drill	Fasteners for Solution Units	10
021-19567-000	Plug, Steel Finishing To Fit 3/4" ID Hole	Fasteners for Solution Units	10
021-19568-000	Plug, Steel Finishing To Fit 1-1/2" Hole	Fasteners for Solution Units	10
021-19568-000	Steel Finishing Plug To Fit 1-1/2" Hole, (Not Shown)	Splice & Split Raceway Kits	37
021-19570-000	Screw, Hex Socket Button Head, 3/8 -16 X 3/4, Stl Zinc Plated	Fasteners for Solution Units	10
021-19570-000	Bolt, 3/8" X 3/4"	Shell Components	35
021-19570-000	Screw, Hex Socket Button Head, 3/8 -16 X 3/4, stl Zinc Pltd, grade 5	Splice & Split Raceway Kits	37
021-19571-000	Wash Lk Th Int 3/4 Stl Zinc Pltd., Std. C-76	Fans And Motors, Securing	32
021-19571-000	Wash Lk Th Int 3/4 Stl Zinc Pltd., Std. C-76	Fasteners for Solution Units	10
021-19579-000	Nut, Rivet Knurled, #10-31, Stl Zinc Pltd	Fasteners for Solution Units	10
021-19580-000	Nut, Rivet Knurled, 3/8-16, Stl Zinc Pltd	Fasteners for Solution Units	10
021-19581-000	Scr, Cap Hex 3/8 - 16 unc - 2a X 2.5, Stl Zinc Pltd	Fasteners for Solution Units	10
021-19582-000	Scr, Pan Hd Phlps, Mach, #10-32 X 1/2 Lg, Stl Zinc Pltd, With Captive Internal Tooth Washer	Fasteners for Solution Units	10
021-19585-000	Screw, 1/4"-14 X 1", Phillips Pan Hd., Self Driller w/washer, Zinc w/epdm .25	Fasteners for Solution Units	10
021-19586-000	Nut, Hex 3/8-16, Zinc Plated	Fasteners for Solution Units	10
021-19586-000	Nut, Hex 3/8-16, Zinc Plated	Shell Components	35
021-19587-000	Rivet, Pop, 3/16"x3/8" Grip, Stl Zinc Pltd	Fasteners for Solution Units	10
021-19750-000	Screw, Bh, Hex Socket	Shell Components	35
024-14920-000	Mtr 50hp 200/208-3-60 Odp High 1800rpm Baldor M2543t-8	Fan Motors	22
024-23174-000	Mtr 1.5hp 200/208-3-60 Odp High 1800rpm Baldor M3154t-8	Fan Motors	22
024-23189-000	Mtr 2hp 230/460-3-60 Odp High 1800rpm Baldor M3157t	Fan Motors	22
024-23191-000	Mtr 30hp 230/460-3-60 Odp High 1800rpm Baldor M2535t	Fan Motors	22
024-23195-000	Mtr 40hp 230/460-3-60 Odp High 1800rpm Baldor M2539t	Fan Motors	22
024-23196-000	Mtr 50hp 230/460-3-60 Odp High 1800rpm Baldor M2543t	Fan Motors	22
024-23197-000	Mtr 60hp 230/460-3-60 Odp High 1800rpm Baldor M2547t	Fan Motors	22
024-23914-000	Mtr 3hp 230/460-3-60 Tefc High 1800rpm Baldor M3611t	Fan Motors	22
024-23915-000	Mtr 5hp 230/460-3-60 Tefc High 1800rpm Baldor M3615t	Fan Motors	22
024-23916-000	Mtr 7.5hp 230/460-3-60 Tefc High 1800rpm Baldor M3710t	Fan Motors	22
024-23917-000	Mtr 10hp 230/460-3-60 Tefc High 1800rpm Baldor M3714t	Fan Motors	22
024-23918-000	Mtr 15hp 230/460-3-60 Tefc High 1800rpm Baldor M2333t	Fan Motors	22
024-23919-000	Mtr 20hp 230/460-3-60 Tefc High 1800rpm Baldor M2334t	Fan Motors	22
024-23920-000	Mtr 25hp 230/460-3-60 Tefc High 1800rpm Baldor M4103t	Fan Motors	22
024-23921-000	Mtr 3hp 200/208-3-60 Tefc High 1800rpm Baldor M3611t-8	Fan Motors	22
024-23922-000	Mtr 5hp 200/208-3-60 Tefc High 1800rpm Baldor M3615t-8	Fan Motors	22
024-23923-000	Mtr 7.5hp 200/208-3-60 Tefc High 1800rpm Baldor M3710t-8	Fan Motors	22

PART NUMBER INDEX			
PART NUMBER	DESCRIPTION	Table	PAGE
024-23924-000	Mtr 10hp 200/208-3-60 Tefc High 1800rpm Baldor M3714t-8	Fan Motors	22
024-23925-000	Mtr 15hp 200/208-3-60 Tefc High 1800rpm Baldor M2333t-8	Fan Motors	22
024-23928-000	Mtr 3hp 230/460-3-60 Odp High 1800rpm Baldor M3211t	Fan Motors	22
024-23929-000	Mtr 5hp 230/460-3-60 Odp High 1800rpm Baldor M3218t	Fan Motors	22
024-23930-000	Mtr 7.5hp 230/460-3-60 Odp High 1800rpm Baldor M3311t	Fan Motors	22
024-23931-000	Mtr 10hp 230/460-3-60 Odp High 1800rpm Baldor M3313t	Fan Motors	22
024-23932-000	Mtr 15hp 230/460-3-60 Odp High 1800rpm Baldor M2513t	Fan Motors	22
024-23933-000	Mtr 20hp 230/460-3-60 Odp High 1800rpm Baldor M2515t	Fan Motors	22
024-23934-000	Mtr 25hp 230/460-3-60 Odp High 1800rpm Baldor M2531t	Fan Motors	22
024-23935-000	Mtr 3hp 200/208-3-60 Odp High 1800rpm Baldor M3211t-8	Fan Motors	22
024-23936-000	Mtr 5hp 200/208-3-60 Odp High 1800rpm Baldor M3218t-8	Fan Motors	22
024-23937-000	Mtr 7.5hp 200/208-3-60 Odp High 1800rpm Baldor M3311t-8	Fan Motors	22
024-23938-000	Mtr 10hp 200/208-3-60 Odp High 1800rpm Baldor M3313t-8	Fan Motors	22
024-23939-000	Mtr 15hp 200/208-3-60 Odp High 1800rpm Baldor M2513t-8	Fan Motors	22
024-23940-000	Mtr 20hp 200/208-3-60 Odp High 1800rpm Baldor M2515t-8	Fan Motors	22
024-23941-000	Mtr 25hp 200/208-3-60 Odp High 1800rpm Baldor M2531t-8	Fan Motors	22
024-26203-000	Mtr 3hp 380-3-50 Odp High 1500rpm Baldor M3211t-50	Fan Motors	22
024-26204-000	Mtr 5hp 380-3-50 Odp High 1500rpm Baldor M3218t-50	Fan Motors	22
024-26205-000	Mtr 7.5hp 380-3-50 Odp High 1500rpm Baldor M3311t-50	Fan Motors	22
024-26221-000	Mtr 10hp 380-3-50 Tefc High 1500rpm Baldor M3714t-50	Fan Motors	22
024-26252-000	Mtr 15hp 380-3-50 Tefc High 1500rpm Baldor M2333t-50	Fan Motors	22
024-26261-000	Mtr 1hp 200/208-3-60 Odp High 1800rpm Baldor M3116t-8	Fan Motors	22
024-26262-000	Mtr 1hp 230/460-3-60 Odp High 1800rpm Baldor M3116t	Fan Motors	22
024-26263-000	Mtr 1.5hp 230/460-3-60 Odp High 1800rpm Baldor M3154t	Fan Motors	22
024-26264-000	Mtr 2hp 200/208-3-60 Odp High 1800rpm Baldor M3157t-8	Fan Motors	22
024-26265-000	Mtr 30hp 200/208-3-60 Odp High 1800rpm Baldor M2535t-8	Fan Motors	22
024-26266-000	Mtr 40hp 200/208-3-60 Odp High 1800rpm Baldor M2539t-8	Fan Motors	22
024-26267-000	Mtr 75hp 230/460-3-60 Odp High 1800rpm Baldor M2551t	Fan Motors	22
024-26268-000	Mtr 100hp 230/460-3-60 Odp High 1800rpm Baldor M2555t	Fan Motors	22
024-26271-000	Mtr 30hp 200/208-3-60 Tefc High 1800rpm Baldor M4104t-8	Fan Motors	22
024-26276-000	Mtr 1hp 200/208-3-60 Tefc High 1800rpm Baldor M3546t-8	Fan Motors	23
024-26277-000	Mtr 1hp 230/460-3-60 Tefc High 1800rpm Baldor M3546t	Fan Motors	23
024-26278-000	Mtr 1.5hp 200/208-3-60 Tefc High 1800rpm Baldor M3554t-8	Fan Motors	23
024-26279-000	Mtr 1.5hp 230/460-3-60 Tefc High 1800rpm Baldor M3554t	Fan Motors	23
024-26280-000	Mtr 2hp 200/208-3-60 Tefc High 1800rpm Baldor M3558t-8	Fan Motors	23
024-26281-000	Mtr 2hp 230/460-3-60 Tefc High 1800rpm Baldor M3558t	Fan Motors	23
024-26282-000	Mtr 30hp 230/460-3-60 Tefc High 1800rpm Baldor M4104t	Fan Motors	23
024-26283-000	Mtr 40hp 230/460-3-60 Tefc High 1800rpm Baldor M4110t	Fan Motors	23
024-26284-000	Mtr 50hp 230/460-3-60 Tefc High 1800rpm Baldor M4115t	Fan Motors	23
024-26285-000	Mtr 60hp 230/460-3-60 Tefc High 1800rpm Baldor M4314t	Fan Motors	23
024-26286-000	Mtr 75hp 230/460-3-60 Tefc High 1800rpm Baldor M4316t	Fan Motors	23
024-26287-000	Mtr 100hp 230/460-3-60 Tefc High 1800rpm Baldor M4400t	Fan Motors	23
024-27005-000	Mtr 1hp 575-3-60 Odp High 1800rpm Baldor M3116t-5	Fan Motors	23
024-27006-000	Mtr 1.5hp 575-3-60 Odp High 1800rpm Baldor M3154t-5	Fan Motors	23
024-27007-000	Mtr 2hp 575-3-60 ODP High 1800rpm Baldor M3157t-5	Fan Motors	23
024-27008-000	Mtr 3hp 575-3-60 ODP High 1800rpm Baldor M3211t-5	Fan Motors	23
024-27009-000	Mtr 5hp 575-3-60 ODP High 1800rpm Baldor M3218t-5	Fan Motors	23
024-27010-000	Mtr 7.5hp 575-3-60 ODP High 1800rpm Baldor M3311t-5	Fan Motors	23

PART NUMBER INDEX			
PART NUMBER	DESCRIPTION	Table	PAGE
024-27011-000	Mtr 10hp 575-3-60 ODP High 1800rpm Baldor M3313t-5	Fan Motors	23
024-27012-000	Mtr 15hp 575-3-60 ODP High 1800rpm Baldor M2513t-5	Fan Motors	23
024-27013-000	Mtr 20hp 575-3-60 ODP High 1800rpm Baldor M2515t-5	Fan Motors	23
024-27014-000	Mtr 25hp 575-3-60 ODP High 1800rpm Baldor M2531t-5	Fan Motors	23
024-27015-000	Mtr 30hp 575-3-60 ODP High 1800rpm Baldor M2535t-5	Fan Motors	23
024-27016-000	Mtr 40hp 575-3-60 ODP High 1800rpm Baldor M2539t-5	Fan Motors	23
024-27017-000	Mtr 50hp 575-3-60 ODP High 1800rpm Baldor M2543t-5	Fan Motors	23
024-27018-000	Mtr 60hp 575-3-60 ODP High 1800rpm Baldor M2547t-5	Fan Motors	23
024-27019-000	Mtr 75hp 575-3-60 ODP High 1800rpm Baldor M2551t-5	Fan Motors	23
024-27020-000	Mtr 100hp 575-3-60 ODP High 1800rpm Baldor M2555t-5	Fan Motors	23
024-27037-000	Mtr 1hp 575-3-60 TEFC High 1800rpm Baldor M3546t-5	Fan Motors	23
024-27038-000	Mtr 1.5hp 575-3-60 TEFC High 1800rpm Baldor M3554t-5	Fan Motors	23
024-27039-000	Mtr 2hp 575-3-60 TEFC High 1800rpm Baldor M3558t-5	Fan Motors	23
024-27040-000	Mtr 3hp 575-3-60 TEFC High 1800rpm Baldor M3611t-5	Fan Motors	23
024-27041-000	Mtr 5hp 575-3-60 TEFC High 1800rpm Baldor M3615t-5	Fan Motors	23
024-27042-000	Mtr 7.5hp 575-3-60 TEFC High 1800rpm Baldor M3710t-5	Fan Motors	23
024-27043-000	Mtr 10hp 575-3-60 TEFC High 1800rpm Baldor M3714t-5	Fan Motors	23
024-27044-000	Mtr 15hp 575-3-60 TEFC High 1800rpm Baldor M2333t-5	Fan Motors	23
024-27045-000	Mtr 20hp 575-3-60 TEFC High 1800rpm Baldor M2334t-5	Fan Motors	23
024-27046-000	Mtr 25hp 575-3-60 TEFC High 1800rpm Baldor M4103t-5	Fan Motors	23
024-27047-000	Mtr 30hp 575-3-60 TEFC High 1800rpm Baldor M4104t-5	Fan Motors	23
024-27048-000	Mtr 40hp 575-3-60 TEFC High 1800rpm Baldor M4110t-5	Fan Motors	23
024-27049-000	Mtr 50hp 575-3-60 TEFC High 1800rpm Baldor M4115t-5	Fan Motors	23
024-27050-000	Mtr 60hp 575-3-60 TEFC High 1800rpm Baldor M4314t-5	Fan Motors	23
024-27051-000	Mtr 75hp 575-3-60 TEFC High 1800rpm Baldor M4316t-5	Fan Motors	23
024-27052-000	Mtr 100hp 575-3-60 TEFC High 1800rpm Baldor M4400t-5	Fan Motors	23
024-27054-000	Mtr 3hp 200/208-3-60 ODP Prem 1800rpm Baldor Em3211t-8	Fan Motors	23
024-27055-000	Mtr 3hp 460-3-60 ODP Prem 1800rpm Baldor Em3211t	Fan Motors	23
024-27055-000	Mtr 3hp 230/460-3-60 ODP Prem 1800rpm Baldor Em3211t	Fan Motors	23
024-27056-000	Mtr 5hp 200/208-3-60 ODP Prem 1800rpm Baldor Em3218t-8	Fan Motors	24
024-27057-000	Mtr 5hp 230/460-3-60 ODP Prem 1800rpm Baldor Em3218t	Fan Motors	24
024-27058-000	Mtr 7.5hp 200/208-3-60 ODP Prem 1800rpm Baldor Em3311t-8	Fan Motors	24
024-27059-000	Mtr 7.5hp 230/460-3-60 ODP Prem 1800rpm Baldor Em3311t	Fan Motors	24
024-27060-000	Mtr 10hp 200/208-3-60 ODP Prem 1800rpm Baldor Em3313t-8	Fan Motors	24
024-27062-000	Mtr 10hp 230/460-3-60 ODP Prem 1800rpm Baldor Em3313t	Fan Motors	24
024-27063-000	Mtr 15hp 200/208-3-60 ODP Prem 1800rpm Baldor Em2513t-8	Fan Motors	24
024-27064-000	Mtr 15hp 230/460-3-60 ODP Prem 1800rpm Baldor Em2513t	Fan Motors	24
024-27065-000	Mtr 20hp 200/208-3-60 ODP Prem 1800rpm Baldor Em2515t-8	Fan Motors	24
024-27066-000	Mtr 20hp 230/460-3-60 ODP Prem 1800rpm Baldor Em2515t	Fan Motors	24
024-27067-000	Mtr 25hp 200/208-3-60 ODP Prem 1800rpm Baldor Em2531t-8	Fan Motors	24
024-27068-000	Mtr 25hp 230/460-3-60 ODP Prem 1800rpm Baldor Em2531t	Fan Motors	24
024-27069-000	Mtr 30hp 200/208-3-60 ODP Prem 1800rpm Baldor Em2535t-8	Fan Motors	24
024-27070-000	Mtr 30hp 230/460-3-60 ODP Prem 1800rpm Baldor Em2535t	Fan Motors	24
024-27071-000	Mtr 40hp 200/208-3-60 ODP Prem 1800rpm Baldor Em2539t-8	Fan Motors	24
024-27072-000	Mtr 40hp 230/460-3-60 ODP Prem 1800rpm Baldor Em2539t	Fan Motors	24
024-27073-000	Mtr 50hp 200/208-3-60 ODP Prem 1800rpm Baldor Em2543t-8	Fan Motors	24
024-27074-000	Mtr 50hp 230/460-3-60 ODP Prem 1800rpm Baldor Em2543t	Fan Motors	24
024-27075-000	Mtr 60hp 200/208-3-60 ODP Prem 1800rpm Baldor Em2547t-8	Fan Motors	24

PART NUMBER INDEX			
PART NUMBER	DESCRIPTION	Table	PAGE
024-27076-000	Mtr 60hp 230/460-3-60 Odp Prem 1800rpm Baldor Em2547t	Fan Motors	24
024-27077-000	Mtr 75hp 200/208-3-60 Odp Prem 1800rpm Baldor Em2551t-8	Fan Motors	24
024-27078-000	Mtr 75hp 230/460-3-60 Odp Prem 1800rpm Baldor Em2551t	Fan Motors	24
024-27079-000	Mtr 100hp 200/208-3-60 Odp Prem 1800rpm Baldor Em2555t-8	Fan Motors	24
024-27080-000	Mtr 100hp 460-3-60 Odp Prem 1800rpm Baldor Em2555t-4	Fan Motors	24
024-27081-000	Mtr 3hp 200/208-3-60 TEFC Prem 1800rpm Baldor Em3661t-8	Fan Motors	24
024-27082-000	Mtr 3hp 230/460-3-60 TEFC Prem 1800rpm Baldor Em3611t	Fan Motors	24
024-27083-000	Mtr 5hp 200/208-3-60 TEFC Prem 1800rpm Baldor Em3665t-8	Fan Motors	24
024-27084-000	Mtr 5hp 230/460-3-60 TEFC Prem 1800rpm Baldor Em3615t	Fan Motors	24
024-27085-000	Mtr 7.5hp 200/208-3-60 TEFC Prem 1800rpm Baldor Em3770t-8	Fan Motors	24
024-27086-000	Mtr 7.5hp 230/460-3-60 TEFC Prem 1800rpm Baldor Em3710t	Fan Motors	24
024-27087-000	Mtr 10hp 200/208-3-60 TEFC Prem 1800rpm Baldor Em3774t-8	Fan Motors	24
024-27088-000	Mtr 10hp 230/460-3-60 TEFC Prem 1800rpm Baldor Em3714t	Fan Motors	24
024-27089-000	Mtr 15hp 200/208-3-60 TEFC Prem 1800rpm Baldor Em2333t-8	Fan Motors	24
024-27090-000	Mtr 15hp 230/460-3-60 TEFC Prem 1800rpm Baldor Em2333t	Fan Motors	24
024-27097-000	Mtr 20hp 200/208-3-60 TEFC Prem 1800rpm Baldor Em2334t-8	Fan Motors	24
024-27098-000	Mtr 20hp 230/460-3-60 TEFC Prem 1800rpm Baldor Em2334t	Fan Motors	24
024-27099-000	Mtr 25hp 200/208-3-60 TEFC Prem 1800rpm Baldor Em4103t-8	Fan Motors	24
024-27300-000	Mtr 25hp 230/460-3-60 TEFC Prem 1800rpm Baldor Em4103t	Fan Motors	24
024-27301-000	Mtr 30hp 230/460-3-60 TEFC Prem 1800rpm Baldor Em4104t	Fan Motors	24
024-27302-000	Mtr 40hp 230/460-3-60 TEFC Prem 1800rpm Baldor Em4110t	Fan Motors	24
024-27303-000	Mtr 50hp 230/460-3-60 TEFC Prem 1800rpm Baldor Em4115t	Fan Motors	24
024-27304-000	Mtr 60hp 230/460-3-60 TEFC Prem 1800rpm Baldor Em4314t	Fan Motors	24
024-27305-000	Mtr 75hp 230/460-3-60 TEFC Prem 1800rpm Baldor Em4316t	Fan Motors	24
024-27306-000	Mtr 100hp 460-3-60 TEFC Prem 1800rpm Baldor Ecp4400t-4	Fan Motors	24
024-27307-000	Mtr 1hp 575-3-60 TEFC Prem 1800rpm Baldor Em3546t-5	Fan Motors	24
024-27308-000	Mtr 1.5hp 575-3-60 TEFC Prem 1800rpm Baldor Em3554t-5	Fan Motors	24
024-27309-000	Mtr 2hp 575-3-60 TEFC Prem 1800rpm Baldor Em3558t-5	Fan Motors	24
024-27310-000	Mtr 3hp 575-3-60 TEFC Prem 1800rpm Baldor Em3611t-5	Fan Motors	25
024-27311-000	Mtr 5hp 575-3-60 TEFC Prem 1800rpm Baldor Em3615t-5	Fan Motors	25
024-27312-000	Mtr 7.5hp 575-3-60 TEFC Prem 1800rpm Baldor Em3710t-5	Fan Motors	25
024-27313-000	Mtr 10hp 575-3-60 TEFC Prem 1800rpm Baldor. Em3714t-5	Fan Motors	25
024-27314-000	Mtr 15hp 575-3-60 TEFC Prem 1800rpm Baldor Em2333t-5	Fan Motors	25
024-27316-000	Mtr 25hp 575-3-60 TEFC Prem 1800rpm Baldor Ecp4103t-5	Fan Motors	25
024-34400-000	Mtr 1hp 230/460-3-60 ODP Prem 1800rpm Baldor Em3116t	Fan Motors	25
024-34402-000	Mtr 1hp 575-3-60 ODP Prem 1800rpm Baldor Em3116t-5	Fan Motors	25
024-34403-000	Mtr 1hp 200/208-3-60 ODP Prem 1800rpm Baldor Em3116t-8	Fan Motors	25
024-34404-000	Mtr 1hp 230/460-3-60 TEFC Prem 1800rpm Baldor Em3546t	Fan Motors	25
024-34406-000	Mtr 1hp 200/208-3-60 TEFC Prem 1800rpm Baldor Em3546t-8	Fan Motors	25
024-34407-000	Mtr 2hp 230/460-3-60 ODP Prem 1800rpm Baldor Em3157t	Fan Motors	25
024-34409-000	Mtr 2hp 575-3-60 ODP Prem 1800rpm Baldor Em3157t-5	Fan Motors	25
024-34410-000	Mtr 2hp 200/208-3-60 ODP Prem 1800rpm Baldor Em3157t-8	Fan Motors	25
024-34411-000	Mtr 2hp 230/460-3-60 TEFC Prem 1800rpm Baldor Em3558t	Fan Motors	25
024-34413-000	Mtr 2hp 200/208-3-60 TEFC Prem 1800rpm Baldor Em3558t-8	Fan Motors	25
024-34414-000	Mtr 3hp 575-3-60 ODP Prem 1800rpm Baldor Em3211t-5	Fan Motors	25
024-34415-000	Mtr 5hp 575-3-60 ODP Prem 1800rpm Baldor Em3218t-5	Fan Motors	25
024-34416-000	Mtr 7.5hp 575-3-60 ODP Prem 1800rpm Baldor Em3311t-5	Fan Motors	25
024-34417-000	Mtr 10hp 575-3-60 ODP Prem 1800rpm Baldor Em3313t-5	Fan Motors	25



PART NUMBER INDEX			
PART NUMBER	DESCRIPTION	Table	PAGE
024-34419-000	Mtr 1.5hp 230/460-3-60 ODP Prem 1800rpm Baldor Em3154t	Fan Motors	25
024-34420-000	Mtr 1.5hp 575-3-60 ODP Prem 1800rpm Baldor Em3154t-5	Fan Motors	25
024-34421-000	Mtr 1.5hp 200/208-3-60 ODP Prem 1800rpm Baldor Em3154t-8	Fan Motors	25
024-34423-000	Mtr 1.5hp 230/460-3-60 TEFC Prem 1800rpm Baldor Em3554t	Fan Motors	25
024-34424-000	Mtr 1.5hp 200/208-3-60 TEFC Prem 1800rpm Baldor Em3554t-8	Fan Motors	25
024-34425-000	Mtr 15hp 575-3-60 ODP Prem 1800rpm Baldor Em2513t-5	Fan Motors	25
024-34426-000	Mtr 20hp 200/208-3-60 TEFC High 1800rpm Baldor M2334t-8	Fan Motors	25
024-34427-000	Mtr 20hp 575-3-60 ODP Prem 1800rpm Baldor Em2515t-5	Fan Motors	25
024-34428-000	Mtr 20hp 575-3-60 TEFC Prem 1800rpm Baldor Ecp2334t-5	Fan Motors	25
024-34429-000	Mtr 25hp 200/208-3-60 TEFC High 1800rpm Baldor M4103t-8	Fan Motors	25
024-34430-000	Mtr 25hp 575-3-60 ODP Prem 1800rpm Baldor Em2531t-5	Fan Motors	25
024-34431-000	Mtr 30hp 575-3-60 ODP Prem 1800rpm Baldor Em2535t-5	Fan Motors	25
024-34432-000	Mtr 30hp 575-3-60 TEFC Prem 1800rpm Baldor Ecp4104t-5	Fan Motors	25
024-34433-000	Mtr 30hp 200/208-3-60 TEFC Prem 1800rpm Baldor Em4104t-8	Fan Motors	25
024-34434-000	Mtr 40hp 200/208-3-60 TEFC High 1800rpm Baldor M4110t-8	Fan Motors	25
024-34435-000	Mtr 40hp 575-3-60 ODP Prem 1800rpm Baldor Em2539t-5	Fan Motors	25
024-34436-000	Mtr 40hp 575-3-60 TEFC Prem 1800rpm Baldor Ecp4110t-5	Fan Motors	25
024-34437-000	Mtr 40hp 200/208-3-60 TEFC Prem 1800rpm Baldor Em4110t-8	Fan Motors	25
024-34438-000	Mtr 50hp 200/208-3-60 TEFC High 1800rpm Baldor M4115t-8	Fan Motors	25
024-34439-000	Mtr 50hp 575-3-60 ODP Prem 1800rpm Baldor Em2543t-5	Fan Motors	25
024-34440-000	Mtr 50hp 575-3-60 TEFC Prem 1800rpm Baldor Ecp4115t-5	Fan Motors	25
024-34441-000	Mtr 50hp 200/208-3-60 TEFC Prem 1800rpm Baldor Em4115t-8	Fan Motors	25
024-34442-000	Mtr 60hp 200/208-3-60 ODP High 1800rpm Baldor M2547t-8	Fan Motors	25
024-34443-000	Mtr 60hp 200/208-3-60 TEFC High 1800rpm Baldor Custom	Fan Motors	25
024-34444-000	Mtr 60hp 575-3-60 ODP Prem 1800rpm Baldor Em2547t-5	Fan Motors	25
024-34445-000	Mtr 60hp 200/208-3-60 TEFC Prem 1800rpm Baldor Custom	Fan Motors	25
024-34446-000	Mtr 60hp 575-3-60 TEFC Prem 1800rpm Baldor Ecp4314t-5	Fan Motors	25
024-34447-000	Mtr 75hp 200/208-3-60 ODP High 1800rpm Baldor M2551t-8	Fan Motors	26
024-34448-000	Mtr 75hp 200/208-3-60 TEFC High 1800rpm Baldor Custom	Fan Motors	26
024-34449-000	Mtr 75hp 575-3-60 ODP Prem 1800rpm Baldor 44wgv126	Fan Motors	26
024-34450-000	Mtr 75hp 200/208-3-60 TEFC Prem 1800rpm Baldor Custom	Fan Motors	26
024-34451-000	Mtr 75hp 575-3-60 TEFC Prem 1800rpm Baldor Ecp4316t-5	Fan Motors	26
024-34452-000	Mtr 100hp 200/208-3-60 ODP High 1800rpm Baldor M2555t-8	Fan Motors	26
024-34453-000	Mtr 100hp 200/208-3-60 TEFC High 1800rpm Baldor Custom	Fan Motors	26
024-34454-000	Mtr 100hp 230/460-3-60 ODP Prem 1800rpm Baldor 16wgv559	Fan Motors	26
024-34455-000	Mtr 100hp 575-3-60 ODP Prem 1800rpm Baldor 16wgv614	Fan Motors	26
024-34456-000	Mtr 100hp 200/208-3-60 TEFC Prem 1800rpm Baldor Custom	Fan Motors	26
024-34457-000	Mtr 100hp 230/460-3-60 TEFC Prem 1800rpm Baldor Custom	Fan Motors	26
024-34458-000	Mtr 100hp 575-3-60 TEFC Prem 1800rpm Baldor Ecp4400t-5	Fan Motors	26
024-34459-000	Mtr 1hp 380-3-50 TEFC High 1500rpm Baldor M3546t-50	Fan Motors	26
024-34460-000	Mtr 1hp 380-3-50 ODP High 1500rpm Baldor M3116t-50	Fan Motors	26
024-34461-000	Mtr 1.5hp 380-3-50 ODP High 1500rpm Baldor M3154t-50	Fan Motors	26
024-34462-000	Mtr 2hp 380-3-50 ODP High 1500rpm Baldor M3157t-50	Fan Motors	26
024-34463-000	Mtr 5hp 380-3-50 TEFC High 1500rpm Baldor M3615t-50	Fan Motors	26
024-34464-000	Mtr 7.5hp 380-3-50 TEFC High 1500rpm Baldor M3710t-50	Fan Motors	26
024-34466-000	Mtr 10hp 380-3-50 ODP High 1500rpm Baldor M3313t-50	Fan Motors	26
024-34467-000	Mtr 15hp 380-3-50 ODP High 1500rpm Baldor M2513t-50	Fan Motors	26
024-34468-000	Mtr 20hp 380-3-50 ODP High 1500rpm Baldor M2515t-50	Fan Motors	26

PART NUMBER INDEX			
PART NUMBER	DESCRIPTION	Table	PAGE
024-34469-000	Mtr 25hp 380-3-50 ODP High 1500rpm Baldor 39x214	Fan Motors	26
024-34470-000	Mtr 30hp 380-3-50 ODP High 1500rpm Baldor 40w989	Fan Motors	26
024-34471-000	Mtr 40hp 380-3-50 ODP High 1500rpm Baldor 40w473	Fan Motors	26
024-34472-000	Mtr 50hp 380-3-50 ODP High 1500rpm Baldor 40w565	Fan Motors	26
024-34473-000	Mtr 60hp 380-3-50 ODP High 1500rpm Baldor 42w598	Fan Motors	26
024-34474-000	Mtr 75hp 380-3-50 ODP High 1500rpm Baldor 42w502	Fan Motors	26
024-34475-000	Mtr 100hp 380-3-50 ODP High 1500rpm Baldor 44w096	Fan Motors	26
024-34819-000	Mtr 1.5hp 380-3-50 TEFC High 1500rpm Baldor M3554t-50	Fan Motors	26
024-34820-000	Mtr 2hp 380-3-50 TEFC High 1500rpm Baldor M3558t-50	Fan Motors	26
024-34821-000	Mtr 3hp 380-3-50 TEFC High 1500rpm Baldor M3611t-50	Fan Motors	26
024-34822-000	Mtr 20hp 380-3-50 TEFC High 1500rpm Baldor M2334t-50	Fan Motors	26
024-34823-000	Mtr 25hp 380-3-50 TEFC High 1500rpm Baldor M4103t-50	Fan Motors	26
024-34824-000	Mtr 30hp 380-3-50 TEFC High 1500rpm Baldor M4104t-50	Fan Motors	26
024-34825-000	Mtr 40hp 380-3-50 TEFC High 1500rpm Baldor M4110t-50	Fan Motors	26
024-34826-000	Mtr 50hp 380-3-50 TEFC High 1500rpm Baldor M4115t-50	Fan Motors	26
024-34827-000	Mtr 60hp 380-3-50 TEFC High 1500rpm Baldor M4314t-50	Fan Motors	26
024-34828-000	Mtr 75hp 380-3-50 TEFC High 1500rpm Baldor 14x116	Fan Motors	26
024-34829-000	Mtr 100hp 380-3-50 TEFC High 1500rpm Baldor 16w740	Fan Motors	26
025-39003-001	Switch, 20 Amp Rocker, Ivory, (Light Switch Only Assembly)	Electrical Replacement Parts	60
025-39003-001	Switch, 20 Amp Rocker, Ivory, (Light Switch / Receptacle Assembly)	Electrical Replacement Parts	60
025-39004-001	Receptacle, 20 Amp, Gfi, Ivory, (Light Switch / Receptacle Assembly)	Electrical Replacement Parts	60
025-39004-001	Receptacle, 20 Amp, Gfi, Ivory (Convenience Outlet), (1 Hour Timer / Receptacle Assembly)	Electrical Replacement Parts	60
025-39007-001	Cover, 1-gang, Dry Type, 1-gfi, (Receptacle Only Assembly)	Electrical Replacement Parts	60
025-39007-001	Cover, 1-gang, Dry Type, 1-gfi, (Light Switch Only Assembly)	Electrical Replacement Parts	60
025-39007-002	Cover, 2-gang, Dry Type, 2-gfi, Red Dot Drytite, (Light Switch / Receptacle Assembly)	Electrical Replacement Parts	60
025-39008-001	Cover, 1-gang, Red Dot, Code Keeper, 1-gfi, (1 Hour Timer Only Assembly)	Electrical Replacement Parts	60
025-39008-002	Cover, 2-gang, 2-gfi, Red Dot, Code Keeper, (1 Hour Timer / Receptacle Assembly)	Electrical Replacement Parts	60
025-39009-001	Cover, 1-gang, Dry Type, Blank, (J-box Only Assembly)	Electrical Replacement Parts	60
025-39012-001	Timer, Switch, 1 Hour w/ Hold, 20 Amps @ 125 Vac, Ivory Decorator, (1 Hour Timer Only Assembly)	Electrical Replacement Parts	60
025-39012-001	Timer, Switch, 1 Hour w/ Hold, 20 Amps @ 125 Vac, Ivory Decorator, (1 Hour Timer / Receptacle Assembly)	Electrical Replacement Parts	60
025-39013-001	Light Fixture w/ Cover	Light Assembly Breakdown	59
025-39014-001	Pull Switch	Light Assembly Breakdown	59
025-39019-001	Light Assembly, w/o Switch, 11"lg.	Light Assemblies	59
025-39019-002	Light Assembly, w/switch, 11"lg.	Light Assemblies	59
025-39019-003	Light Assembly, w/o Switch, 17"lg.	Light Assemblies	59
025-39019-004	Light Assembly, w/switch, 17"lg.	Light Assemblies	59
025-39019-005	Light Assembly, w/o Switch, 28"lg.	Light Assemblies	59
025-39019-006	Light Assembly, w/switch, 28"lg.	Light Assemblies	59
025-39020-001	Harness, Panel to Wire Track, #12 ga w/Conduit, 1' LG.	Wiring-harn. Lt Assy - Pnl To Wire Track	61
025-39020-002	Harness, Panel to Wire Track, #12 ga w/Conduit, 2' LG.	Wiring-harn. Lt Assy - Pnl To Wire Track	61
025-39020-003	Harness, Panel to Wire Track, #12 ga w/Conduit, 3' LG.	Wiring-harn. Lt Assy - Pnl To Wire Track	61
025-39020-004	Harness, Panel to Wire Track, #12 ga w/Conduit, 4' LG.	Wiring-harn. Lt Assy - Pnl To Wire Track	61
025-39020-005	Harness, Panel to Wire Track, #12 ga w/Conduit, 5' LG.	Wiring-harn. Lt Assy - Pnl To Wire Track	61

PART NUMBER INDEX			
PART NUMBER	DESCRIPTION	Table	PAGE
025-39020-006	Harness, Panel to Wire Track, #12 ga w/Conduit, 6' LG.	Wiring-harn. Lt Assy - Pnl To Wire Track	61
025-39020-007	Harness, Panel to Wire Track, #12 ga w/Conduit, 7' LG.	Wiring-harn. Lt Assy - Pnl To Wire Track	61
025-39020-008	Harness, Panel to Wire Track, #12 ga w/Conduit, 8' LG.	Wiring-harn. Lt Assy - Pnl To Wire Track	61
025-39020-009	Harness, Panel to Wire Track, #12 ga w/Conduit, 9' LG.	Wiring-harn. Lt Assy - Pnl To Wire Track	61
025-39020-010	Harness, Panel to Wire Track, #12 ga w/Conduit, 10' LG.	Wiring-harn. Lt Assy - Pnl To Wire Track	61
025-39022-001	Harness Wiretrack, 12 ga, 3 wire, 1' LG.	Wiring-harnesses Light Assy - Wire Track	62
025-39022-002	Harness Wiretrack, 12 ga, 3 wire, 2' LG.	Wiring-harnesses Light Assy - Wire Track	62
025-39022-003	Harness Wiretrack, 12 ga, 3 wire, 3' LG.	Wiring-harnesses Light Assy - Wire Track	62
025-39022-004	Harness Wiretrack, 12 ga, 3 wire, 4' LG.	Wiring-harnesses Light Assy - Wire Track	62
025-39022-005	Harness Wiretrack, 12 ga, 3 wire, 5' LG.	Wiring-harnesses Light Assy - Wire Track	62
025-39022-006	Harness Wiretrack, 12 ga, 3 wire, 6' LG.	Wiring-harnesses Light Assy - Wire Track	62
025-39022-007	Harness Wiretrack, 12 ga, 3 wire, 7' LG.	Wiring-harnesses Light Assy - Wire Track	62
025-39022-008	Harness Wiretrack, 12 ga, 3 wire, 8' LG.	Wiring-harnesses Light Assy - Wire Track	62
025-39022-009	Harness Wiretrack, 12 ga, 3 wire, 9' LG.	Wiring-harnesses Light Assy - Wire Track	62
025-39022-010	Harness Wiretrack, 12 ga, 3 wire, 10' LG.	Wiring-harnesses Light Assy - Wire Track	62
025-39022-011	Harness Wiretrack, 12 ga, 3 wire, 11' LG.	Wiring-harnesses Light Assy - Wire Track	62
025-39022-012	Harness Wiretrack, 12 ga, 3 wire, 12' LG.	Wiring-harnesses Light Assy - Wire Track	62
025-39022-013	Harness Wiretrack, 12 ga, 3 wire, 13' LG.	Wiring-harnesses Light Assy - Wire Track	62
025-39022-014	Harness Wiretrack, 12 ga, 3 wire, 14' LG.	Wiring-harnesses Light Assy - Wire Track	62
025-39022-015	Harness Wiretrack, 12 ga, 3 wire, 15' LG.	Wiring-harnesses Light Assy - Wire Track	62
025-39022-016	Harness Wiretrack, 12 ga, 3 wire, 16' LG.	Wiring-harnesses Light Assy - Wire Track	62
025-39022-017	Harness Wiretrack, 12 ga, 3 wire, 17 LG.	Wiring-harnesses Light Assy - Wire Track	62
025-39022-018	Harness Wiretrack, 12 ga, 3 wire, 18' LG.	Wiring-harnesses Light Assy - Wire Track	62
025-39022-019	Harness Wiretrack, 12 ga, 3 wire, 19' LG.	Wiring-harnesses Light Assy - Wire Track	62
025-39022-020	Harness Wiretrack, 12 ga, 3 wire, 20' LG.	Wiring-harnesses Light Assy - Wire Track	62
025-39042-001	Wire Connectors	Motor Wiring Parts	27
025-39042-003	Wire Connectors	Motor Wiring Parts	27
025-39043-001	Wire Connectors	Motor Wiring Parts	27
025-39043-002	Wire Connectors	Motor Wiring Parts	27
025-39043-003	Wire Connectors	Motor Wiring Parts	27
025-39044-001	Wire Connectors	Motor Wiring Parts	27
025-39044-002	Wire Connectors	Motor Wiring Parts	27
025-39049-001	Flexible Cable Sleeves	Motor Wiring Parts	27
025-39049-002	Flexible Cable Sleeves	Motor Wiring Parts	27
025-39049-003	Flexible Cable Sleeves	Motor Wiring Parts	27
025-39049-004	Flexible Cable Sleeves	Motor Wiring Parts	27
025-39105-001	2KVA Transformer Panel, 200-208v to 120vac	Transformer Panel	64
025-39105-003	2KVA Transformer Panel, 230v to 120vac	Transformer Panel	64
025-39105-005	2KVA Transformer Panel, 460v to 120vac	Transformer Panel	64
025-39105-007	2KVA Transformer Panel, 575v to 120vac	Transformer Panel	64
026-02043-000	Filter, Throwaway, 20w x 20h x 2d, Fbrgls	Filters	46
026-03617-000	Filter, Throwaway, 16w x 20h x 2d, Fbrgls	Filters	46
026-10448-000	Filter, Cleanable, 16w x 20h x 2d, Alum	Filters	44
026-10450-000	Filter, Cleanable, 20w x 20h x 2d, Alum	Filters	44
026-21062-000	Filter, Perfectpleat, 16w x 20h x 2d, 30% Eff	Filters	45
026-21063-000	Filter, Perfectpleat, 20w x 20h x 2d, 30% Eff	Filters	45
026-28200-000	Filter, Pleated, 16w x 20h x 4d, 30% Eff	Filters	45
026-28202-000	Filter, Pleated, 20w x 20h x 4d, 30% Eff	Filters	45

PART NUMBER INDEX			
PART NUMBER	DESCRIPTION	Table	PAGE
026-32404-001	Filter, Cart, Varicel x Sh, 20w x 20h x 12d, 60-65%	Filters	45
026-32404-002	Filter, Cart, Varicel x Sh, 20w x 24h x 12d, 60-65%	Filters	45
026-32404-002	Filter, Cart, Varicel x Sh, 20w x 24h x 12d, 60-65%	Filters	46
026-32404-003	Filter, Cart, Varicel x Sh, 20w x 20h x 12d, 80-85%	Filters	45
026-32404-004	Filter, Cart, Varicel x Sh, 20w x 24h x 12d, 80-85%	Filters	45
026-32404-005	Filter, Cart, Varicel x Sh, 20w x 20h x 12d, 90-95%	Filters	45
026-32404-006	Filter, Cart, Varicel x Sh, 20w x 24h x 12d, 90-95%	Filters	45
026-32404-006	Filter, Cart, Varicel x Sh, 20w x 24h x 12d, 90-95%	Filters	46
026-32404-007	Filter, Cart, Varicel x Sh, 12w x 24h x 12d, 60-65%	Filters	45
026-32404-007	Filter, Cart, Varicel x Sh, 12w x 24h x 12d, 60-65%	Filters	46
026-32404-008	Filter, Cart, Varicel x Sh, 24w x 24h x 12d, 60-65%	Filters	46
026-32404-009	Filter, Cart, Varicel x Sh, 12w x 24h x 12d, 80-85%	Filters	45
026-32404-009	Filter, Cart, Varicel x Sh, 12w x 24h x 12d, 80-85%	Filters	46
026-32404-010	Filter, Cart, Varicel x Sh, 24w x 24h x 12d, 80-85%	Filters	46
026-32404-011	Filter, Cart, Varicel x Sh, 12w x 24h x 12d, 90-95%	Filters	45
026-32404-011	Filter, Cart, Varicel x Sh, 12w x 24h x 12d, 90-95%	Filters	46
026-32404-012	Filter, Cart, Varicel x Sh, 24w x 24h x 12d, 90-95%	Filters	46
026-32404-013	Filter, Cart, Varicel x Sh, 16w x 20h x 12d, 80-85%	Filters	45
026-32405-001	Filter, Bag, 20w x 20h x 22d, 60-65%	Filters	42
026-32405-001	Filter, Bag, 20w x 20h x 22d, 60-65%	Filters	44
026-32405-002	Filter, Bag, 20w x 24h x 22d, 60-65%	Filters	42
026-32405-002	Filter, Bag, 20w x 24h x 22d, 60-65%	Filters	44
026-32405-003	Filter, Bag, 24w x 12h x 22d, 60-65%	Filters	43
026-32405-003	Filter, Bag, 24w x 12h x 22d, 60-65%	Filters	44
026-32405-004	Filter, Bag, 20w x 20h x 22d, 80-85%	Filters	42
026-32405-004	Filter, Bag, 20w x 20h x 22d, 80-85%	Filters	44
026-32405-005	Filter, Bag, 20w x 24h x 22d, 80-85%	Filters	42
026-32405-005	Filter, Bag, 20w x 24h x 22d, 80-85%	Filters	44
026-32405-006	Filter, Bag, 24w x 12h x 22d, 80-85%	Filters	43
026-32405-006	Filter, Bag, 24w x 12h x 22d, 80-85%	Filters	44
026-32405-007	Filter, Bag, 20w x 20h x 22d, 90-95%	Filters	42
026-32405-007	Filter, Bag, 20w x 20h x 22d, 90-95%	Filters	44
026-32405-008	Filter, Bag, 20w x 24h x 22d, 90-95%	Filters	42
026-32405-008	Filter, Bag, 20w x 24h x 22d, 90-95%	Filters	44
026-32405-009	Filter, Bag, 24w x 12h x 22d, 90-95%	Filters	43
026-32405-009	Filter, Bag, 24w x 12h x 22d, 90-95%	Filters	44
026-32405-019	Filter, Bag, 12w x 24h x 22d, 60-65%	Filters	42
026-32405-019	Filter, Bag, 12w x 24h x 22d, 60-65%	Filters	44
026-32405-020	Filter, Bag, 24w x 24h x 22d, 60-65%	Filters	42
026-32405-020	Filter, Bag, 24w x 24h x 22d, 60-65%	Filters	44
026-32405-021	Filter, Bag, 12w x 24h x 22d, 80-85%	Filters	42
026-32405-021	Filter, Bag, 12w x 24h x 22d, 80-85%	Filters	44
026-32405-022	Filter, Bag, 24w x 24h x 22d, 80-85%	Filters	42
026-32405-022	Filter, Bag, 24w x 24h x 22d, 80-85%	Filters	44
026-32405-023	Filter, Bag, 12w x 24h x 22d, 90-95%	Filters	42
026-32405-023	Filter, Bag, 12w x 24h x 22d, 90-95%	Filters	44
026-32405-024	Filter, Bag, 24w x 24h x 22d, 90-95%	Filters	43
026-32405-024	Filter, Bag, 24w x 24h x 22d, 90-95%	Filters	44

PART NUMBER INDEX			
PART NUMBER	DESCRIPTION	Table	PAGE
026-32405-031	Filter, Bag, 24w x 20h x 22d, 60-65%	Filters	42
026-32405-031	Filter, Bag, 24w x 20h x 22d, 60-65%	Filters	44
026-32405-032	Filter, Bag, 24w x 20h x 22d, 80-85%	Filters	42
026-32405-032	Filter, Bag, 24w x 20h x 22d, 80-85%	Filters	44
026-32405-033	Filter, Bag, 24w x 20h x 22d, 90-95%	Filters	42
026-32405-033	Filter, Bag, 24w x 20h x 22d, 90-95%	Filters	44
026-32405-037	Filter, Bag, 16w x 20h x 22d, 60-65%	Filters	42
026-32405-037	Filter, Bag, 16w x 20h x 22d, 60-65%	Filters	44
026-32405-038	Filter, Bag, 16w x 20h x 22d, 80-85%	Filters	42
026-32405-038	Filter, Bag, 16w x 20h x 22d, 80-85%	Filters	44
026-32405-039	Filter, Bag, 16w x 20h x 22d, 90-95%	Filters	42
026-32405-039	Filter, Bag, 16w x 20h x 22d, 90-95%	Filters	44
026-32405-040	Filter, Bag, 20w x 16h x 22d, 60-65%	Filters	42
026-32405-040	Filter, Bag, 20w x 16h x 22d, 60-65%	Filters	44
026-32405-041	Filter, Bag, 20w x 16h x 22d, 80-85%	Filters	42
026-32405-041	Filter, Bag, 20w x 16h x 22d, 80-85%	Filters	44
026-32405-042	Filter, Bag, 20w x 16h x 22d, 90-95%	Filters	42
026-32405-042	Filter, Bag, 20w x 16h x 22d, 90-95%	Filters	44
026-32406-001	Filter, Perfectpleat, 12w x 24h x 2d, 30% Eff	Filters	45
026-32406-002	Filter, Perfectpleat, 20w x 24h x 2d, 30% Eff	Filters	45
026-32406-003	Filter, Perfectpleat, 24w x 24h x 2d, 30% Eff	Filters	45
026-32406-004	Filter, Pleated, 12w x 24h x 4d, 30% Eff	Filters	45
026-32406-006	Filter, Pleated, 24w x 24h x 4d, 30% Eff	Filters	45
026-32406-007	Filter, Pleated, 20w x 24h x 4d, 30% Eff	Filters	45
026-32406-008	Filter, Perfectpleat, 24w x 12h x 2d, 30% Eff	Filters	45
026-32406-009	Filter, Perfectpleat, 24w x 20h x 2d, 30% Eff	Filters	45
026-32406-010	Filter, Perfectpleat, 20w x 16h x 2d, 30% Eff	Filters	45
026-32407-001	Filter, Throwaway, 12w x 24h x 2d, Fbrgls	Filters	46
026-32407-002	Filter, Throwaway, 24w x 24h x 2d, Fbrgls	Filters	46
026-32407-009	Filter, Throwaway, 20w x 24h x 2d, Fbrgls	Filters	46
026-32408-001	Filter, Cleanable, 12w x 24h x 2d, Alum	Filters	44
026-32408-002	Filter, Cleanable, 24w x 24h x 2d, Alum	Filters	44
026-32408-009	Filter, Cleanable, 20w x 24h x 2d, Alum	Filters	44
026-32410-008	Filter, Varicel, (Mini Pleated), 12w x 24h x 4d, 80-85%	Filters	43
026-32410-008	Filter, Varicel, (Mini Pleated), 12w x 24h x 4d, 80-85%	Filters	44
026-32410-008	Filter, Varicel, (Mini Pleated), 12w x 24h x 4d, 80-85%	Filters	45
026-32410-009	Filter, Varicel, (Mini Pleated), 16w x 20h x 4d, 80-85%	Filters	43
026-32410-009	Filter, Varicel, (Mini Pleated), 16w x 20h x 4d, 80-85%	Filters	44
026-32410-009	Filter, Varicel, (Mini Pleated), 16w x 20h x 4d, 80-85%	Filters	45
026-32410-011	Filter, Varicel, (Mini Pleated), 20w x 20h x 4d, 80-85%	Filters	43
026-32410-011	Filter, Varicel, (Mini Pleated), 20w x 20h x 4d, 80-85%	Filters	44
026-32410-012	Filter, Varicel, (Mini Pleated), 20w x 24h x 4d, 80-85%	Filters	43
026-32410-012	Filter, Varicel, (Mini Pleated), 20w x 24h x 4d, 80-85%	Filters	45
026-32410-014	Filter, Varicel, (Mini Pleated), 24w x 24h x 4d, 80-85%	Filters	43
026-32410-014	Filter, Varicel, (Mini Pleated), 24w x 24h x 4d, 80-85%	Filters	45
026-33587-001	Filter, HEPA, 24w x 12h x 11.5d	Filters	42
026-33587-002	Filter, HEPA, 24w x 15h x 11.5d	Filters	42
026-33587-003	Filter, HEPA, 24w x 24h x 11.5d	Filters	42

PART NUMBER INDEX			
PART NUMBER	DESCRIPTION	Table	PAGE
026-33587-004	Filter, HEPA, 24w x 30h x 11.5d	Filters	42
026-33587-005	Filter, HEPA, 12w x 24h x 11.5d	Filters	42
026-33587-006	Filter, HEPA, 12w x 30h x 11.5d	Filters	42
026-33587-007	Filter, HEPA, 30w x 12h x 11.5d	Filters	42
026-33587-008	Filter, HEPA, 30w x 15h x 11.5d	Filters	42
026-33587-009	Filter, HEPA, 30w x 24h x 11.5d	Filters	42
026-33587-010	Filter, HEPA, 30w x 30h x 11.5d	Filters	42
026-33587-101	Filter, HEPA, 24w x 12h x 11.5d	Filters	42
026-33587-102	Filter, HEPA, 24w x 15h x 11.5d	Filters	42
026-33587-103	Filter, HEPA, 24w x 24h x 11.5d	Filters	42
026-33587-104	Filter, HEPA, 24w x 30h x 11.5d	Filters	42
026-33587-105	Filter, HEPA, 12w x 24h x 11.5d	Filters	42
026-33587-106	Filter, HEPA, 12w x 30h x 11.5d	Filters	42
026-33587-107	Filter, HEPA, 30w x 12h x 11.5d	Filters	42
026-33587-108	Filter, HEPA, 30w x 15h x 11.5d	Filters	42
026-33587-109	Filter, HEPA, 30w x 24h x 11.5d	Filters	42
026-33587-110	Filter, HEPA, 30w x 30h x 11.5d	Filters	42
026-33782-001	Filter, Varicel, (Mini Pleated), 12w x 24h x 4d, 60-65%	Filters	43
026-33782-001	Filter, Varicel, (Mini Pleated), 12w x 24h x 4d, 60-65%	Filters	44
026-33782-001	Filter, Varicel, (Mini Pleated), 12w x 24h x 4d, 60-65%	Filters	45
026-33782-002	Filter, Varicel, (Mini Pleated), 16w x 20h x 4d, 60-65%	Filters	43
026-33782-002	Filter, Varicel, (Mini Pleated), 16w x 20h x 4d, 60-65%	Filters	44
026-33782-002	Filter, Varicel, (Mini Pleated), 16w x 20h x 4d, 60-65%	Filters	45
026-33782-005	Filter, Varicel, (Mini Pleated), 20w x 20h x 4d, 60-65%	Filters	43
026-33782-005	Filter, Varicel, (Mini Pleated), 20w x 20h x 4d, 60-65%	Filters	44
026-33782-006	Filter, Varicel, (Mini Pleated), 20w x 24h x 4d, 60-65%	Filters	43
026-33782-006	Filter, Varicel, (Mini Pleated), 20w x 24h x 4d, 60-65%	Filters	44
026-33782-006	Filter, Varicel, (Mini Pleated), 20w x 24h x 4d, 60-65%	Filters	45
026-33782-008	Filter, Varicel, (Mini Pleated), 24w x 24h x 4d, 60-65%	Filters	43
026-33782-008	Filter, Varicel, (Mini Pleated), 24w x 24h x 4d, 60-65%	Filters	45
026-33783-001	Filter, Varicel, (Mini Pleated), 12w x 24h x 4d, 90-95%	Filters	43
026-33783-001	Filter, Varicel, (Mini Pleated), 12w x 24h x 4d, 90-95%	Filters	44
026-33783-001	Filter, Varicel, (Mini Pleated), 12w x 24h x 4d, 90-95%	Filters	45
026-33783-002	Filter, Varicel, (Mini Pleated), 16w x 20h x 4d, 90-95%	Filters	43
026-33783-002	Filter, Varicel, (Mini Pleated), 16w x 20h x 4d, 90-95%	Filters	44
026-33783-002	Filter, Varicel, (Mini Pleated), 16w x 20h x 4d, 90-95%	Filters	45
026-33783-005	Filter, Varicel, (Mini Pleated), 20w x 20h x 4d, 90-95%	Filters	43
026-33783-005	Filter, Varicel, (Mini Pleated), 20w x 20h x 4d, 90-95%	Filters	44
026-33783-006	Filter, Varicel, (Mini Pleated), 20w x 24h x 4d, 90-95%	Filters	43
026-33783-006	Filter, Varicel, (Mini Pleated), 20w x 24h x 4d, 90-95%	Filters	45
026-33783-008	Filter, Varicel, (Mini Pleated), 24w x 24h x 4d, 90-95%	Filters	43
026-33783-008	Filter, Varicel, (Mini Pleated), 24w x 24h x 4d, 90-95%	Filters	45
026-36339-000	4" Clip, Prefilter Retainer Clip, Varicel Dh	Universal Frame Latch Selection	57
026-36339-001	2" Clip, Prefilter Retainer Clip, Varicel Dh	Universal Frame Latch Selection	57
026-36340-009	Filter, Cart, Varicel x Sh, 16w x 20h x 12d, 60-65%	Filters	45
026-36342-009	Filter, Cart, Varicel x Sh, 16w x 20h x 12d, 90-95%	Filters	45
026-36343-000	SL-12" , Knock On Spring Latch, Varicel Dh	Universal Frame Latch Selection	57
026-40200-001	Filetr, Cart, Varicel x Dh, 20w x 20h x 12d, 60-65%	Filters	43

PART NUMBER INDEX			
PART NUMBER	DESCRIPTION	Table	PAGE
026-40200-002	Filetr, Cart, Varicel x Dh, 20w x 24h x 12d, 60-65%	Filters	43
026-40200-003	Filetr, Cart, Varicel x Dh, 20w x 20h x 12d, 80-85%	Filters	43
026-40200-004	Filetr, Cart, Varicel x Dh, 20w x 24h x 12d, 80-85%	Filters	43
026-40200-005	Filetr, Cart, Varicel x Dh, 20w x 20h x 12d, 90-95%	Filters	43
026-40200-006	Filetr, Cart, Varicel x Dh, 20w x 24h x 12d, 90-95%	Filters	43
026-40200-007	Filetr, Cart, Varicel x Dh, 12w x 24h x 12d, 60-65%	Filters	43
026-40200-007	Filetr, Cart, Varicel x Dh, 12w x 24h x 12d, 60-65%	Filters	44
026-40200-008	Filetr, Cart, Varicel x Dh, 24w x 24h x 12d, 60-65%	Filters	44
026-40200-009	Filetr, Cart, Varicel x Dh, 12w x 24h x 12d, 80-85%	Filters	43
026-40200-009	Filetr, Cart, Varicel x Dh, 12w x 24h x 12d, 80-85%	Filters	44
026-40200-010	Filetr, Cart, Varicel x Dh, 24w x 24h x 12d, 80-85%	Filters	44
026-40200-011	Filetr, Cart, Varicel x Dh, 12w x 24h x 12d, 90-95%	Filters	43
026-40200-011	Filetr, Cart, Varicel x Dh, 12w x 24h x 12d, 90-95%	Filters	44
026-40200-012	Filetr, Cart, Varicel x Dh, 24w x 24h x 12d, 90-95%	Filters	43
026-40200-013	Filetr, Cart, Varicel x Dh, 16w x 20h x 12d, 80-85%	Filters	43
026-40200-014	Filetr, Cart, Varicel x Dh, 16w x 20h x 12d, 60-65%	Filters	43
026-40200-015	Filetr, Cart, Varicel x Dh, 16w x 20h x 12d, 90-95%	Filters	43
026-40824-001	Filter, HEPA, 15w x 24h x 11.5d	Filters	42
026-40824-002	Filter, HEPA, 15w x 30h x 11.5d	Filters	42
026-40824-101	Filter, HEPA, 15w x 24h x 11.5d	Filters	42
026-40824-102	Filter, HEPA, 15w x 30h x 11.5d	Filters	42
026-41366-001	Filtr,cleanable,15w_16h_1d,alum	OA Hood Moisture Eliminator Filters	47
026-41366-002	Filtr,cleanable,15w_17h_1d,alum	OA Hood Moisture Eliminator Filters	47
026-41366-004	Filtr,cleanable,15w_20h_1d,alum	OA Hood Moisture Eliminator Filters	47
026-41366-007	Filtr,cleanable,15w_24h_1d,alum	OA Hood Moisture Eliminator Filters	47
026-41366-008	Filtr,cleanable,15w_25h_1d,alum	OA Hood Moisture Eliminator Filters	47
026-41366-010	Filtr,cleanable,15w_27h_1d,alum	OA Hood Moisture Eliminator Filters	47
026-41366-011	Filtr,cleanable,16w_16h_1d,alum	OA Hood Moisture Eliminator Filters	47
026-41366-012	Filtr,cleanable,16w_17h_1d,alum	OA Hood Moisture Eliminator Filters	47
026-41366-013	Filtr,cleanable,16w_18h_1d,alum	OA Hood Moisture Eliminator Filters	47
026-41366-014	Filtr,cleanable,16w_19h_1d,alum	OA Hood Moisture Eliminator Filters	47
026-41366-015	Filtr,cleanable,16w_20h_1d,alum	OA Hood Moisture Eliminator Filters	47
026-41366-016	Filtr,cleanable,16w_22h_1d,alum	OA Hood Moisture Eliminator Filters	47
026-41366-018	Filtr,cleanable,16w_25h_1d,alum	OA Hood Moisture Eliminator Filters	47
026-41366-020	Filtr,cleanable,16w_28h_1d,alum	OA Hood Moisture Eliminator Filters	48
026-41366-022	Filtr,cleanable,17w_17h_1d,alum	OA Hood Moisture Eliminator Filters	48
026-41366-023	Filtr,cleanable,17w_19h_1d,alum	OA Hood Moisture Eliminator Filters	48
026-41366-024	Filtr,cleanable,17w_20h_1d,alum	OA Hood Moisture Eliminator Filters	48
026-41366-025	Filtr,cleanable,17w_21h_1d,alum	OA Hood Moisture Eliminator Filters	48
026-41366-026	Filtr,cleanable,17w_22h_1d,alum	OA Hood Moisture Eliminator Filters	48
026-41366-027	Filtr,cleanable,17w_23h_1d,alum	OA Hood Moisture Eliminator Filters	48
026-41366-028	Filtr,cleanable,17w_24h_1d,alum	OA Hood Moisture Eliminator Filters	48
026-41366-029	Filtr,cleanable,17w_25h_1d,alum	OA Hood Moisture Eliminator Filters	48
026-41366-029	Filtr,cleanable,17w_25h_1d,alum	OA Hood Moisture Eliminator Filters	49
026-41366-030	Filtr,cleanable,17w_26h_1d,alum	OA Hood Moisture Eliminator Filters	49
026-41366-031	Filtr,cleanable,17w_27h_1d,alum	OA Hood Moisture Eliminator Filters	49
026-41366-031	Filtr,cleanable,17w_27h_1d,alum	OA Hood Moisture Eliminator Filters	49
026-41366-032	Filtr,cleanable,17w_28h_1d,alum	OA Hood Moisture Eliminator Filters	49





PART NUMBER INDEX			
PART NUMBER	DESCRIPTION	Table	PAGE
026-41366-081	Filtr,cleanable,23w_23h_1d,alum	OA Hood Moisture Eliminator Filters	53
026-41366-082	Filtr,cleanable,23w_24h_1d,alum	OA Hood Moisture Eliminator Filters	53
026-41366-083	Filtr,cleanable,23w_25h_1d,alum	OA Hood Moisture Eliminator Filters	53
026-41366-084	Filtr,cleanable,23w_26h_1d,alum	OA Hood Moisture Eliminator Filters	53
026-41366-085	Filtr,cleanable,23w_27h_1d,alum	OA Hood Moisture Eliminator Filters	53
026-41366-086	Filtr,cleanable,23w_28h_1d,alum	OA Hood Moisture Eliminator Filters	53
026-41366-086	Filtr,cleanable,23w_28h_1d,alum	OA Hood Moisture Eliminator Filters	54
026-41366-088	Filtr,cleanable,24w_24h_1d,alum	OA Hood Moisture Eliminator Filters	54
026-41366-089	Filtr,cleanable,24w_25h_1d,alum	OA Hood Moisture Eliminator Filters	54
026-41366-090	Filtr,cleanable,24w_26h_1d,alum	OA Hood Moisture Eliminator Filters	54
026-41366-091	Filtr,cleanable,24w_27h_1d,alum	OA Hood Moisture Eliminator Filters	54
026-41366-092	Filtr,cleanable,24w_28h_1d,alum	OA Hood Moisture Eliminator Filters	54
026-41366-093	Filtr,cleanable,24w_29h_1d,alum	OA Hood Moisture Eliminator Filters	54
026-41366-095	Filtr,cleanable,25w_26h_1d,alum	OA Hood Moisture Eliminator Filters	54
026-41366-096	Filtr,cleanable,25w_27h_1d,alum	OA Hood Moisture Eliminator Filters	54
026-41366-097	Filtr,cleanable,25w_28h_1d,alum	OA Hood Moisture Eliminator Filters	54
026-41366-099	Filtr,cleanable,26w_26h_1d,alum	OA Hood Moisture Eliminator Filters	54
026-41366-100	Filtr,cleanable,26w_27h_1d,alum	OA Hood Moisture Eliminator Filters	54
026-41366-100	Filtr,cleanable,26w_27h_1d,alum	OA Hood Moisture Eliminator Filters	55
026-41366-101	Filtr,cleanable,26w_28h_1d,alum	OA Hood Moisture Eliminator Filters	55
026-41366-103	Filtr,cleanable,27w_27h_1d,alum	OA Hood Moisture Eliminator Filters	55
026-41366-104	Filtr,cleanable,27w_28h_1d,alum	OA Hood Moisture Eliminator Filters	55
026-41366-105	Filtr,cleanable,27w_29h_1d,alum	OA Hood Moisture Eliminator Filters	55
026-41366-107	Filtr,cleanable,15w_15h_1d,alum	OA Hood Moisture Eliminator Filters	47
026-41366-108	Filtr,cleanable,15w_18h_1d,alum	OA Hood Moisture Eliminator Filters	47
026-41366-109	Filtr,cleanable,15w_21h_1d,alum	OA Hood Moisture Eliminator Filters	47
026-41366-110	Filtr,cleanable,15w_28h_1d,alum	OA Hood Moisture Eliminator Filters	47
026-41366-111	Filtr,cleanable,15w_29h_1d,alum	OA Hood Moisture Eliminator Filters	47
026-41366-112	Filtr,cleanable,16w_21h_1d,alum	OA Hood Moisture Eliminator Filters	47
026-41366-113	Filtr,cleanable,16w_23h_1d,alum	OA Hood Moisture Eliminator Filters	47
026-41366-114	Filtr,cleanable,17w_18h_1d,alum	OA Hood Moisture Eliminator Filters	48
026-41366-115	Filtr,cleanable,18w_29h_1d,alum	OA Hood Moisture Eliminator Filters	50
026-41366-116	Filtr,cleanable,16w_27h_1d,alum	OA Hood Moisture Eliminator Filters	48
026-41366-117	Filtr,cleanable,16w_24h_1d,alum	OA Hood Moisture Eliminator Filters	47
028-11778-000	Foam Tape	Shell Components	35
028-11778-010	Gasket, Neoprene, Closed Cell, B/G, 1.25W x 0.25THK	Gasket/Caulk/Adhesive for Solution Units	11
028-11791-010	Gasket, Polyurethane, Open Cell, B/G, 1.0W x 1.0THK	Gasket/Caulk/Adhesive for Solution Units	11
028-11861-000	Grommet, Supply/return Coil Hdr, 1/8" PVC, For 3.00" Conn.	Gasket/Caulk/Adhesive for Solution Units	11
028-11861-000	Grommet, Supply/return Coil Header, 1/8" PVC	Gasket/Caulk/Adhesive for Solution Units	11
028-11864-010	Gasket, Neoprene, Closed Cell, B/G, 0.75W x 0.5THK	Gasket/Caulk/Adhesive for Solution Units	11
028-11865-010	Foam, #2 Polyester, Open Cell, 2W x 2THK, 4LG	Gasket/Caulk/Adhesive for Solution Units	11
028-11865-010	Gasket, Neoprene, Closed Cell, B/G, 1.0W x 2.0THK	Gasket/Caulk/Adhesive for Solution Units	11
028-11866-001	Tape, Polyethylene, Double, 0.375W x 0.032THK, 5,184 In / Roll	Gasket/Caulk/Adhesive for Solution Units	11
028-11866-002	Tape, Polyethylene, Double, 0.375W x 0.032THK	Gasket/Caulk/Adhesive for Solution Units	11
028-11866-010	Tape, Polyethylene, Double Sided, .38W x 0.13THK, Acrylic,	Gasket/Caulk/Adhesive for Solution Units	11
028-11867-010	Gasket, Neoprene, Closed Cell, B/G, 1.25W x .50THK	Gasket/Caulk/Adhesive for Solution Units	11
028-11871-000	Grommet, Supply/Return Coil Hdr, 1/8" PVC, for 2.5 & 2.0" Conn..	Gasket/Caulk/Adhesive for Solution Units	11
028-11872-000	Grommet, Sup/Ret Coil Hdr, 1/8" PVC, for 1.5, 1.25 & 1.0" Conn.	Gasket/Caulk/Adhesive for Solution Units	11

PART NUMBER INDEX			
PART NUMBER	DESCRIPTION	Table	PAGE
028-11873-010	Gasket, Neoprene, Closed Cell, Grey, .75W X .25THK	Gasket/Caulk/Adhesive for Solution Units	12
028-11875-010	Gasket, Ethafoam 221,Closed Cell, White, 1.5W X .13THK, Scott Mfg or Equal	Gasket/Caulk/Adhesive for Solution Units	12
029-01048-000	L-30 Single Latch	Universal Frame Latch Selection	57
029-01048-005	L-10 Single Latch	Universal Frame Latch Selection	57
029-01048-006	L-20 Single Latch	Universal Frame Latch Selection	57
029-01048-007	L-40 Single Latch	Universal Frame Latch Selection	57
029-01048-008	L-50 Single Latch	Universal Frame Latch Selection	57
029-01048-009	Double Latch, L-42	Universal Frame Latch Selection	57
029-01048-010	Double Latch, L-41	Universal Frame Latch Selection	57
029-01048-011	Double Latch, L-44	Universal Frame Latch Selection	57
029-01048-012	L10 - Knockon Latch	Universal Frame Latch Selection	57
029-01048-013	L40 - Knockon Latch	Universal Frame Latch Selection	57
029-01048-014	L20 - Knockon Latch	Universal Frame Latch Selection	57
029-21340-000	Lifting Lug, 6" Baserail	Shell Components	35
029-21340-000	Lug,lifting,baserail, For 6" Baserail Only	Splice & Split Baserail Kits	36
029-21364-001	Restraint Thrust 350lbs/pr	Thrust Restraint Kits	17
029-21364-001	Restraint Thrust 350lbs/Pr	Thrust Restraint Kits	18
029-21364-002	Restraint Thrust 550lbs/pr	Thrust Restraint Kits	17
029-21364-002	Restraint Thrust 550lbs/Pr	Thrust Restraint Kits	18
029-21364-003	Restraint Thrust 750lbs/pr	Thrust Restraint Kits	17
029-21364-003	Restraint Thrust 750lbs/Pr	Thrust Restraint Kits	18
029-21364-004	Restraint Thrust 1500lbs/pr	Thrust Restraint Kits	17
029-21365-000	Lifting Lug, 8" & 10" Baserail	Splice & Split Baserail Kits	36
029-21365-000	Lifting Lug, 8" & 10" Baserail	Shell Components	35
029-22024-002	Top Cap Assy	Isolators	33
029-22024-003	Top Cap Assy	Isolators	33
029-22024-003	Top Cap Assy	Isolators	34
029-22024-004	Top Cap Assy	Isolators	33
029-22025-002	Isolator, 1" Outer Spring, Alcy-90	Isolators	33
029-22025-004	Isolator, 1" Outer Spring, Awcy-200	Isolators	33
029-22025-004	Isolator, 1" Outer Spring, Awcy-219	Isolators	33
029-22025-004	Isolator, 1" Outer Spring, Awcy-221	Isolators	33
029-22025-004	Isolator, 1" Outer Spring, Awcy-222	Isolators	33
029-22025-007	Isolator, 1" Outer Spring, Alcy-92	Isolators	33
029-22025-008	Isolator, 1" Inner Spring	Isolators	33
029-22025-010	Isolator, 1" Inner Spring	Isolators	33
029-22025-011	Isolator, 1" Outer Spring, Alcy-94	Isolators	33
029-22025-012	Isolator, 1" Outer Spring, Awcy-400	Isolators	33
029-22025-012	Isolator, 1" Outer Spring, Awcy-419	Isolators	33
029-22025-012	Isolator, 1" Outer Spring, Awcy-423	Isolators	33
029-22025-013	Isolator, 1" Outer Spring, Alcy-95	Isolators	33
029-22025-014	Isolator, 1" Inner Spring	Isolators	33
029-22025-015	Isolator, 1" Outer Spring, Awcy-624	Isolators	33
029-22025-016	Isolator, 1" Outer Spring, Awcy-600	Isolators	33
029-22025-017	Isolator, 1" Inner Spring	Isolators	33
029-22025-019	Isolator, 1" Outer Spring, Awcy-1023	Isolators	33
029-22025-019	Isolator, 1" Outer Spring, Awcy-1024	Isolators	33

PART NUMBER INDEX			
PART NUMBER	DESCRIPTION	Table	PAGE
029-22025-022	Isolator, 2" Outer Spring, Alcy-84	Isolators	33
029-22025-023	Isolator, 2" Outer Spring, Alcy-85	Isolators	33
029-22025-024	Isolator, 2" Outer Spring, Alcy-86	Isolators	33
029-22025-025	Isolator, 2" Outer Spring, Awcy-401	Isolators	34
029-22025-026	Isolator, 2" Outer Spring, Alcy-87	Isolators	33
029-22025-027	Isolator, 2" Outer Spring, Awcy-402	Isolators	34
029-22025-028	Isolator, 2" Outer Spring, Alcy-203	Isolators	33
029-22025-029	Isolator, 2" Outer Spring, Awcy-403	Isolators	34
029-22025-031	Isolator, 2" Outer Spring, Awcy-404	Isolators	34
029-22025-032	Isolator, 2" Outer Spring, Awcy-405	Isolators	34
029-22025-033	Isolator, 2" Outer Spring, Alcy-205	Isolators	33
029-22025-034	Isolator, 2" Outer Spring, Awcy-406	Isolators	34
029-22025-034	Isolator, 2" Outer Spring, Awcy-407	Isolators	34
029-22025-034	Isolator, 2" Outer Spring, Awcy-408	Isolators	34
029-22025-034	Isolator, 2" Outer Spring, Awcy-409	Isolators	34
029-22025-035	Isolator, 2" Inner Spring	Isolators	34
029-22025-036	Isolator, 2" Inner Spring	Isolators	34
029-22025-037	Isolator, 2" Inner Spring	Isolators	34
029-22025-038	Isolator, 1" Outer Spring, Alcy-97	Isolators	33
029-22025-039	Isolator, 1" Outer Spring, Alcy-99	Isolators	33
029-22025-040	Isolator, 1" Outer Spring, Awcy-1621	Isolators	33
029-22025-040	Isolator, 1" Outer Spring, Awcy-1622	Isolators	33
029-22025-040	Isolator, 1" Outer Spring, Awcy-1626	Isolators	33
029-22025-040	Isolator, 1" Outer Spring, Awcy-1627	Isolators	33
029-22025-040	Isolator, 1" Outer Spring, Awcy-1631	Isolators	33
029-22025-040	Isolator, 1" Outer Spring, Awcy-1632	Isolators	33
029-22025-043	Isolator, 1" Inner Spring	Isolators	33
029-22025-044	Isolator, 1" Inner Spring	Isolators	33
029-22025-045	Isolator, 1" Inner Spring	Isolators	33
029-22025-046	Isolator, 1" Inner Spring	Isolators	33
029-22025-047	Isolator, 2" Outer Spring, Alcy-81	Isolators	33
029-22025-048	Isolator, 2" Outer Spring, Alcy-82	Isolators	33
029-22025-049	Isolator, 2" Outer Spring, Alcy-83	Isolators	33
029-22025-050	Isolator, 2" Outer Spring, Alcy-206	Isolators	33
029-22025-051	Isolator, 1" Outer Spring, Alcy-96	Isolators	33
029-22025-052	Isolator, 1" Outer Spring, Alcy-93	Isolators	33
029-22025-053	Isolator, 2" Outer Spring, Alcy-204	Isolators	33
029-22025-054	Isolator, 2" Outer Spring, Alcy-207	Isolators	33
029-22025-055	Isolator, 2" Outer Spring, Alcy-208	Isolators	33
029-22025-056	Isolator, 1" Inner Spring	Isolators	33
029-22025-056	Isolator, 1" Inner Spring	Isolators	33
029-22039-000	Lifting Lug, Raceway	Shell Components	35
029-22039-000	Lifting Lug	Splice & Split Raceway Kits	37
029-22043-000	Insert, Raceway Top, Shipping Split	Shell Components	35
029-22043-000	Insert, Raceway	Splice & Split Raceway Kits	37
029-22044-000	Insert, Raceway Bottom, Shipping Split	Shell Components	35
029-22044-000	Insert, Raceway Bottom, Shipping Split	Splice & Split Raceway Kits	37
029-22047-000	Bracket, Tie Down	Shell Components	35

PART NUMBER INDEX			
PART NUMBER	DESCRIPTION	Table	PAGE
029-22048-000	Insert, Raceway Bottom, Splice	Shell Components	35
029-22048-000	Insert, Raceway Splice	Splice & Split Raceway Kits	37
029-22070-000	Lug, Lifting, Corner, Xt, .164 Thk, Galv.	Shell Components	35
029-22070-000	Lug,lifting,corner,xt, .164_thk,g90_glv	Splice & Split Raceway Kits	37
029-22081-000	Latch, HEPA Single, 11-1/2"	Visual Control Filter Clamps For Hepa Filters	58
029-22082-000	Latch, HEPA Double, 11-1/2"	Visual Control Filter Clamps For Hepa Filters	58
029-24219-002	Bottom Cup	Isolators	33
029-24219-003	Bottom Cup	Isolators	33
029-24219-003	Bottom Cup	Isolators	34
029-24219-004	Bottom Cup	Isolators	33
034-12001-001	Handle,Type_L,Lock_Non,Out-Swg,Roller_Straight,w/Screw & Cover Plug.	Door Latching Parts	13
034-12001-005	Inside Handle w/ Red Plastic Grip	Door Latching Parts	13
034-12001-006	Handle,Type_L,Lock_Non,In-Swg ,Roller_Off-Set,w/Screw & Cover Plug.	Door Latching Parts	13
034-12001-007	Handle,Type_L,Lock_Key,Out-Swg,Roller_Straight,w/Screw & Cover Plug, Key The Same,York Std.	Door Latching Parts	13
034-12001-010	Handle,Type_L,Lock_Key,In-Swg , Roller_Off-Set,w/Screw & Cover Plug, Key The Same,York Std.	Door Latching Parts	13
034-12001-011	Handle,Type_L,Lock_Pad,Out-Swg, Roller_Straight,w/Screw & Cover Plug.	Door Latching Parts	13
034-12001-012	Handle,Type_L,Lock_Pad,In-Swg ,Roller_Off-Set,w/Screw & Cover Plug.	Door Latching Parts	13
034-12002-001	Mechanism, Latching,Includes Bushing, Lock nut, & Jam Nut.	Door Latching Parts	13
034-12002-007	Plug, Cover For Latch Mechanism	Door Latching Parts	13
034-12002-007	Cover Plug For Latching Mechanism For Single Point To Cover Outside Latching Mech.	Door Latching Parts	13
034-12002-009	3/8 Sae Flat Washer	Door Latching Parts	13
034-12002-010	Linkage Adapter For 8 Mm (0.315") Dia Rods	Door Latching Parts	13
034-12002-011	Single Point Roller Cam, Snub Nose Outswing Doors Only	Door Latching Parts	13
044-02912-000	Ultra Flex Elastomeric, #2260-0100(White) Coating: *an Expiration Date Required on This Product (Drain Pan)	Gasket/caulk/adhesive For Solution Units	12
044-02912-010	Coating, Ultra Flex Elastomeric, Mastic Coating for Drain Pan	Gasket/caulk/adhesive For Solution Units	12
086-01320-001	Small Thrust Rest Brkt	Thrust Restraint Kits	17
086-01320-001	Small Thrust Rest Brkt	Thrust Restraint Kits	18
086-01320-002	Large Thrust Rest Brkt	Thrust Restraint Kits	17
086-01320-002	Large Thrust Rest Brkt	Thrust Restraint Kits	18
086-01321-001	Thrust Rest Support	Thrust Restraint Kits	17
086-01321-002	Thrust Rest Support	Thrust Restraint Kits	17
086-01321-003	Thrust Rest Support	Thrust Restraint Kits	17
086-01321-004	Thrust Rest Support	Thrust Restraint Kits	17
086-01321-005	Thrust Rest Support	Thrust Restraint Kits	17
086-01321-006	Thrust Rest Support	Thrust Restraint Kits	17
086-01321-007	Thrust Rest Support	Thrust Restraint Kits	17
086-01321-008	Thrust Rest Support	Thrust Restraint Kits	17
086-01321-009	Thrust Rest Support	Thrust Restraint Kits	17
086-01321-010	Thrust Rest Support	Thrust Restraint Kits	18
086-01321-011	Thrust Rest Support	Thrust Restraint Kits	18
086-01321-012	Thrust Rest Support	Thrust Restraint Kits	18

PART NUMBER INDEX			
PART NUMBER	DESCRIPTION	Table	PAGE
086-01321-013	Thrust Rest Support	Thrust Restraint Kits	18
086-01321-014	Thrust Rest Support	Thrust Restraint Kits	18
086-01321-015	Thrust Rest Support	Thrust Restraint Kits	18
086-01321-016	Thrust Rest Support	Thrust Restraint Kits	18
086-01321-017	Thrust Rest Support	Thrust Restraint Kits	18
086-01321-018	Thrust Rest Support	Thrust Restraint Kits	18
086-01321-019	Thrust Rest Support	Thrust Restraint Kits	18
086-01321-020	Thrust Rest Support	Thrust Restraint Kits	18
086-01321-021	Thrust Rest Support	Thrust Restraint Kits	18
086-01321-022	Thrust Rest Support	Thrust Restraint Kits	18
086-01321-023	Thrust Rest Support	Thrust Restraint Kits	18
086-01321-024	Thrust Rest Support	Thrust Restraint Kits	18
086-01322-002	Thrust Restraint SST Plate	Thrust Restraint Kits	17
086-01837-008	Wireway Access Plate, Blank.	Wireway Access Plates	41
086-01837-009	Wireway Access Plate 1/2" Conduit, Sst	Wireway Access Plates	41
086-01837-010	Wireway Access Plate 3/4" Conduit, Sst	Wireway Access Plates	41
086-01837-011	Wireway Access Plate 1" Conduit, Sst	Wireway Access Plates	41
086-01837-012	Wireway Access Plate, Blank.	Wireway Access Plates	41
086-01837-013	Wireway Access Plate 1/2" Conduit, Sst	Wireway Access Plates	41
086-01837-014	Wireway Access Plate 3/4" Conduit, Sst	Wireway Access Plates	41
086-01923-001	Raceway Positioning Angle, No Lifting	Shell Components	35
086-01923-001	Raceway Positioning Angle	Splice & Split Raceway Kits	37
086-02023-001	Rod 0.315" Dia 10" Long Zinc Plated	Door Latching Parts	13
086-02023-002	Rod 0.315" Dia 13" Long Zinc Plated	Door Latching Parts	13
086-02023-003	Rod 0.315" Dia 16" Long Zinc Plated	Door Latching Parts	13
086-02023-004	Rod 0.315" Dia 19" Long Zinc Plated	Door Latching Parts	13
086-02023-005	Rod 0.315" Dia 22" Long Zinc Plated	Door Latching Parts	13
086-02023-006	Rod 0.315" Dia 25" Long Zinc Plated	Door Latching Parts	13
086-02023-007	Rod 0.315" Dia 28" Long Zinc Plated	Door Latching Parts	13
086-02023-008	Rod 0.315" Dia 31" Long Zinc Plated	Door Latching Parts	13
086-02023-009	Rod 0.315" Dia 34" Long Zinc Plated	Door Latching Parts	13
086-02023-010	Rod 0.315" Dia 37" Long Zinc Plated	Door Latching Parts	13
086-02023-011	Rod 0.315" Dia 40" Long Zinc Plated	Door Latching Parts	13
086-02023-012	Rod 0.315" Dia 43" Long Zinc Plated	Door Latching Parts	13
086-02023-013	Rod 0.315" Dia 46" Long Zinc Plated	Door Latching Parts	14
086-02023-014	Rod 0.315" Dia 49" Long Zinc Plated	Door Latching Parts	14
086-02023-015	Rod 0.315" Dia 52" Long Zinc Plated	Door Latching Parts	14
086-02023-016	Rod 0.315" Dia 55" Long Zinc Plated	Door Latching Parts	14
086-02023-017	Rod 0.315" Dia 58" Long Zinc Plated	Door Latching Parts	14
086-02023-018	Rod 0.315" Dia 61" Long Zinc Plated	Door Latching Parts	14
086-02023-019	Rod 0.315" Dia 64" Long Zinc Plated	Door Latching Parts	14
086-02023-020	Rod 0.315" Dia 67" Long Zinc Plated	Door Latching Parts	14
086-02023-021	Rod 0.315" Dia 70" Long Zinc Plated	Door Latching Parts	14
086-02023-022	Rod 0.315" Dia 73" Long Zinc Plated	Door Latching Parts	14
086-02023-023	Rod 0.315" Dia 76" Long Zinc Plated	Door Latching Parts	14
086-02023-024	Rod 0.315" Dia 79" Long Zinc Plated	Door Latching Parts	14
086-02023-025	Rod 0.315" Dia 82" Long Zinc Plated	Door Latching Parts	14
086-02023-026	Rod 0.315" Dia 85" Long Zinc Plated	Door Latching Parts	14

PART NUMBER INDEX			
PART NUMBER	DESCRIPTION	Table	PAGE
086-02023-027	Rod 0.315" Dia 88" Long Zinc Plated	Door Latching Parts	14
086-02023-028	Rod 0.315" Dia 91" Long Zinc Plated	Door Latching Parts	14
086-02023-029	Rod 0.315" Dia 94" Long Zinc Plated	Door Latching Parts	14
086-02023-030	Rod 0.315" Dia 97" Long Zinc Plated	Door Latching Parts	14
086-02023-031	Rod 0.315" Dia 100" Long Zinc Plated	Door Latching Parts	14
086-02023-032	Rod 0.315" Dia 103" Long Zinc Plated	Door Latching Parts	14
086-02023-033	Rod 0.315" Dia 106" Long Zinc Plated	Door Latching Parts	14
086-02023-034	Rod 0.315" Dia 109" Long Zinc Plated	Door Latching Parts	14
086-02023-035	Rod 0.315" Dia 112" Long Zinc Plated	Door Latching Parts	14
086-02023-036	Rod 0.315" Dia 115" Long Zinc Plated	Door Latching Parts	14
086-02023-037	Rod 0.315" Dia 118" Long Zinc Plated	Door Latching Parts	14
086-02026-000	Splice Plate, Raceway, No Lifting	Shell Components	35
086-02026-000	Splice Plate - Rcway - No Lifting.	Splice & Split Raceway Kits	37
086-02027-001	3" Baserail Splice Angle, Non Lifting	Shell Components	35
086-02027-001	Splice Angle 3" - Baserails Splice Piece	Splice & Split Baserail Kits	36
086-02027-002	6" Baserail Splice Angle, Non Lifting	Shell Components	35
086-02027-002	Splice Angle 6" - Baserails Splice Piece	Splice & Split Baserail Kits	36
086-02027-003	8" & 10" Baserail Splice Angle, Non Lifting	Shell Components	35
086-02027-003	Splice Angle 8" - Baserails Splice Piece	Splice & Split Baserail Kits	36
086-23690-001	Plate, Liner Cover, Minihelic li, 18 Ga., Stainless Steel	Filter Gage Kits	65
086-23690-001	Plate, Liner Cover, Minihelic li, 18 Ga., Stainless Steel	Filter Gage Kits	65
087-40048-050	C-channel Trim, 47.938"	C-channel Trim	66
087-40072-050	C-channel Trim, 71.938"	C-channel Trim	66
087-40127-050	C-channel Trim, 126.938"	C-channel Trim	66
386-01156-001	Light Switch / Receptacle assembly	Switch/receptacle	63
386-01157-001	Light Switch Only assembly	Switch/receptacle	63
386-01158-001	Receptacle Only assembly	Switch/receptacle	63
386-01159-001	J-box Only assembly	Switch/receptacle	63
386-01160-001	Harness, Tier to Tier, #12 ga w/Conduit, 3' LG.	Wiring-harnesses Lt. Assy. - Tier To Tier	63
386-01160-001	Harness, Tier to Tier, #12 ga w/Conduit, 3' LG.	Wiring-harnesses Lt. Assy. - Tier To Tier	63
386-01160-002	Harness, Tier to Tier, #12 ga w/Conduit, 4' LG.	Wiring-harnesses Lt. Assy. - Tier To Tier	63
386-01160-002	Harness, Tier to Tier, #12 ga w/Conduit, 4' LG.	Wiring-harnesses Lt. Assy. - Tier To Tier	63
386-01160-002	Harness, Tier to Tier, #12 ga w/Conduit, 4' LG.	Wiring-harnesses Lt. Assy. - Tier To Tier	63
386-01160-002	Harness, Tier to Tier, #12 ga w/Conduit, 4' LG.	Wiring-harnesses Lt. Assy. - Tier To Tier	63
386-01160-003	Harness, Tier to Tier, #12 ga w/Conduit, 5' LG.	Wiring-harnesses Lt. Assy. - Tier To Tier	63
386-01160-003	Harness, Tier to Tier, #12 ga w/Conduit, 5' LG.	Wiring-harnesses Lt. Assy. - Tier To Tier	63
386-01160-003	Harness, Tier to Tier, #12 ga w/Conduit, 5' LG.	Wiring-harnesses Lt. Assy. - Tier To Tier	63
386-01160-003	Harness, Tier to Tier, #12 ga w/Conduit, 5' LG.	Wiring-harnesses Lt. Assy. - Tier To Tier	63
386-01160-004	Harness, Tier to Tier, #12 ga w/Conduit, 6' LG.	Wiring-harnesses Lt. Assy. - Tier To Tier	63
386-01160-004	Harness, Tier to Tier, #12 ga w/Conduit, 6' LG.	Wiring-harnesses Lt. Assy. - Tier To Tier	63
386-01160-004	Harness, Tier to Tier, #12 ga w/Conduit, 6' LG.	Wiring-harnesses Lt. Assy. - Tier To Tier	63
386-01160-004	Harness, Tier to Tier, #12 ga w/Conduit, 6' LG.	Wiring-harnesses Lt. Assy. - Tier To Tier	63
386-01160-005	Harness, Tier to Tier, #12 ga w/Conduit, 7' LG.	Wiring-harnesses Lt. Assy. - Tier To Tier	63
386-01160-005	Harness, Tier to Tier, #12 ga w/Conduit, 7' LG.	Wiring-harnesses Lt. Assy. - Tier To Tier	63
386-01160-005	Harness, Tier to Tier, #12 ga w/Conduit, 7' LG.	Wiring-harnesses Lt. Assy. - Tier To Tier	63
386-01160-005	Harness, Tier to Tier, #12 ga w/Conduit, 7' LG.	Wiring-harnesses Lt. Assy. - Tier To Tier	63
386-01160-006	Harness, Tier to Tier, #12 ga w/Conduit, 8' LG.	Wiring-harnesses Lt. Assy. - Tier To Tier	63
386-01160-006	Harness, Tier to Tier, #12 ga w/Conduit, 8' LG.	Wiring-harnesses Lt. Assy. - Tier To Tier	63

PART NUMBER INDEX			
PART NUMBER	DESCRIPTION	Table	PAGE
386-01160-007	Harness, Tier to Tier, #12 ga w/Conduit, 9' LG.	Wiring-harnesses Lt. Assy. - Tier To Tier	63
386-01160-007	Harness, Tier to Tier, #12 ga w/Conduit, 9' LG.	Wiring-harnesses Lt. Assy. - Tier To Tier	63
386-01160-008	Harness, Tier to Tier, #12 ga w/Conduit, 10' LG.	Wiring-harnesses Lt. Assy. - Tier To Tier	63
386-01160-008	Harness, Tier to Tier, #12 ga w/Conduit, 10' LG.	Wiring-harnesses Lt. Assy. - Tier To Tier	63
386-01160-009	Harness, Tier to Tier, #12 ga w/Conduit, 11' LG.	Wiring-harnesses Lt. Assy. - Tier To Tier	63
386-01160-009	Harness, Tier to Tier, #12 ga w/Conduit, 11' LG.	Wiring-harnesses Lt. Assy. - Tier To Tier	63
386-01160-010	Harness, Tier to Tier, #12 ga w/Conduit, 12' LG.	Wiring-harnesses Lt. Assy. - Tier To Tier	63
386-01161-001	Filter Gage Assembly - Single & Total Filter Bank Kit	Filter Gage Kits	65
386-01161-002	Filter Gage Assembly - Combined Filters Kit	Filter Gage Kits	65
386-02177-000	Kit, Latching Mechanism, Door	Door Latching Parts	14
386-02206-001	1 Hour Timer Only assembly	Switch/receptacle	63
386-02207-001	1 Hour Timer / Receptacle assembly	Switch/receptacle	63
386-02271-001	Harness, Wiretrack Tee Kit	Wiring-harnesses Lt. Assy. - Tier To Tier	63
386-02271-001	Harness, Wiretrack Tee Kit	Wiring-harnesses Light Assy - Wire Track	62
386-11022-001	Corner Connector, Top & Bottom, With Shroud	Shell Components	35
386-11022-001	Corner Connector, Top & Bottom, With Shroud	Splice & Split Raceway Kits	37
386-17216-001	End Corners Kit - Xti No Baserail, Xti w/ Baserail , Xto w/ Baserail	Splice & Split Raceway Kits	37
386-17216-002	Split Kit - w/ Lifting Xto & Xti	Splice & Split Raceway Kits	37
386-17216-003	Splice Kit - Top Xto & Xti	Splice & Split Raceway Kits	37
386-17216-004	Splice Kit - Bottom w/ Lifting Xto & Xti	Splice & Split Raceway Kits	37
386-17216-005	End Corners Kit - Xto No Baserail	Splice & Split Raceway Kits	37
386-17216-006	Split Kit - w/o Lifting Xto & Xti	Splice & Split Raceway Kits	37
386-17216-007	Splice Kit - Bottom w/o Lifting Xto & Xti	Splice & Split Raceway Kits	37
386-17216-008	Split/splice Kit, Baserail 6" Only With Lifting	Splice & Split Baserail Kits	36
386-17216-009	Split/splice Kit, Baserail 8" & 10" Only With Lifting	Splice & Split Baserail Kits	36
386-17216-010	Split/splice Kit, Baserail 3" Only Without Lifting	Splice & Split Baserail Kits	36
386-17216-011	Splice Kit, Baserail 6" Only Without Lifting	Splice & Split Baserail Kits	36
386-17216-012	Splice Kit, Baserail 8 & 10" Only Without Lifting	Splice & Split Baserail Kits	36
386-17791-001	Thrust Restraint Kit	Thrust Restraint Kit Selection	16
386-17791-001	Thrust Rest Kit	Thrust Restraint Kits	17
386-17791-002	Thrust Restraint Kit	Thrust Restraint Kit Selection	16
386-17791-002	Thrust Restraint Kit	Thrust Restraint Kit Selection	16
386-17791-002	Thrust Rest Kit	Thrust Restraint Kits	17
386-17791-003	Thrust Restraint Kit	Thrust Restraint Kit Selection	16
386-17791-003	Thrust Rest Kit	Thrust Restraint Kits	17
386-17791-004	Thrust Restraint Kit	Thrust Restraint Kit Selection	16
386-17791-004	Thrust Rest Kit	Thrust Restraint Kits	17
386-17791-005	Thrust Restraint Kit	Thrust Restraint Kit Selection	16
386-17791-005	Thrust Rest Kit	Thrust Restraint Kits	17
386-17791-006	Thrust Restraint Kit	Thrust Restraint Kit Selection	16
386-17791-006	Thrust Rest Kit	Thrust Restraint Kits	17
386-17791-007	Thrust Restraint Kit	Thrust Restraint Kit Selection	16
386-17791-007	Thrust Rest Kit	Thrust Restraint Kits	17
386-17791-008	Thrust Restraint Kit	Thrust Restraint Kit Selection	16
386-17791-008	Thrust Rest Kit	Thrust Restraint Kits	17
386-17791-009	Thrust Restraint Kit	Thrust Restraint Kit Selection	16
386-17791-009	Thrust Rest Kit	Thrust Restraint Kits	17
386-17791-010	Thrust Restraint Kit	Thrust Restraint Kit Selection	16

PART NUMBER INDEX			
PART NUMBER	DESCRIPTION	Table	PAGE
386-17791-010	Thrust Rest Kit	Thrust Restraint Kits	17
386-17791-011	Thrust Restraint Kit	Thrust Restraint Kit Selection	16
386-17791-011	Thrust Rest Kit	Thrust Restraint Kits	17
386-17791-012	Thrust Restraint Kit	Thrust Restraint Kit Selection	16
386-17791-012	Thrust Rest Kit	Thrust Restraint Kits	17
386-17791-013	Thrust Restraint Kit	Thrust Restraint Kit Selection	16
386-17791-013	Thrust Rest Kit	Thrust Restraint Kits	17
386-17791-014	Thrust Restraint Kit	Thrust Restraint Kit Selection	16
386-17791-014	Thrust Rest Kit	Thrust Restraint Kits	17
386-17791-015	Thrust Restraint Kit	Thrust Restraint Kit Selection	16
386-17791-015	Thrust Rest Kit	Thrust Restraint Kits	17
386-17791-016	Thrust Restraint Kit	Thrust Restraint Kit Selection	16
386-17791-016	Thrust Rest Kit	Thrust Restraint Kits	17
386-17791-017	Thrust Restraint Kit	Thrust Restraint Kit Selection	16
386-17791-017	Thrust Rest Kit	Thrust Restraint Kits	17
386-17791-018	Thrust Restraint Kit	Thrust Restraint Kit Selection	16
386-17791-018	Thrust Rest Kit	Thrust Restraint Kits	17
386-17791-019	Thrust Restraint Kit	Thrust Restraint Kit Selection	16
386-17791-019	Thrust Restraint Kit	Thrust Restraint Kits	18
386-17791-020	Thrust Restraint Kit	Thrust Restraint Kit Selection	16
386-17791-020	Thrust Restraint Kit	Thrust Restraint Kits	18
386-17791-021	Thrust Restraint Kit	Thrust Restraint Kit Selection	16
386-17791-021	Thrust Restraint Kit	Thrust Restraint Kits	18
386-17791-022	Thrust Restraint Kit	Thrust Restraint Kit Selection	16
386-17791-022	Thrust Restraint Kit	Thrust Restraint Kits	18
386-17791-023	Thrust Restraint Kit	Thrust Restraint Kit Selection	16
386-17791-023	Thrust Restraint Kit	Thrust Restraint Kits	18
386-17791-024	Thrust Restraint Kit	Thrust Restraint Kit Selection	16
386-17791-024	Thrust Restraint Kit	Thrust Restraint Kits	18
386-17791-025	Thrust Restraint Kit	Thrust Restraint Kit Selection	16
386-17791-025	Thrust Restraint Kit	Thrust Restraint Kits	18
386-17791-026	Thrust Restraint Kit	Thrust Restraint Kit Selection	16
386-17791-026	Thrust Restraint Kit	Thrust Restraint Kits	18
386-17791-027	Thrust Restraint Kit	Thrust Restraint Kit Selection	16
386-17791-027	Thrust Restraint Kit	Thrust Restraint Kits	18
386-17791-028	Thrust Restraint Kit	Thrust Restraint Kit Selection	16
386-17791-028	Thrust Restraint Kit	Thrust Restraint Kits	18
386-17791-029	Thrust Restraint Kit	Thrust Restraint Kit Selection	16
386-17791-029	Thrust Restraint Kit	Thrust Restraint Kits	18
386-17791-030	Thrust Restraint Kit	Thrust Restraint Kit Selection	16
386-17791-030	Thrust Restraint Kit	Thrust Restraint Kits	18
386-17791-031	Thrust Restraint Kit	Thrust Restraint Kit Selection	16
386-17791-031	Thrust Restraint Kit	Thrust Restraint Kits	18
386-17791-032	Thrust Restraint Kit	Thrust Restraint Kit Selection	16
386-17791-032	Thrust Restraint Kit	Thrust Restraint Kits	18
386-17791-033	Thrust Restraint Kit	Thrust Restraint Kit Selection	16
386-17791-033	Thrust Restraint Kit	Thrust Restraint Kits	18
386-23937-001	Adjustable Motor Base Assembly	Adjustable Motor Bases	28



PART NUMBER INDEX			
PART NUMBER	DESCRIPTION	Table	PAGE
386-23940-001	Adjustable Motor Base Assembly	Adjustable Motor Bases	28
386-23943-001	Adjustable Motor Base Assembly	Adjustable Motor Bases	28
386-23946-001	Adjustable Motor Base Assembly	Adjustable Motor Bases	28
386-23946-001	Adjustable Motor Base Assembly	Adjustable Motor Bases	29
386-23949-001	Adjustable Motor Base Assembly	Adjustable Motor Bases	28
386-23949-001	Adjustable Motor Base Assembly	Adjustable Motor Bases	29
386-23952-001	Adjustable Motor Base Assembly	Adjustable Motor Bases	28
386-23952-001	Adjustable Motor Base Assembly	Adjustable Motor Bases	29
386-23956-001	Adjustable Motor Base Assembly	Adjustable Motor Bases	28
386-23956-001	Adjustable Motor Base Assembly	Adjustable Motor Bases	29
386-23956-001	Adjustable Motor Base Assembly	Adjustable Motor Bases	29
386-23956-001	Adjustable Motor Base Assembly	Adjustable Motor Bases	29
386-23960-001	Adjustable Motor Base Assembly	Adjustable Motor Bases	28
386-23960-001	Adjustable Motor Base Assembly	Adjustable Motor Bases	29
386-23960-001	Adjustable Motor Base Assembly	Adjustable Motor Bases	30
386-23965-001	Adjustable Motor Base Assembly	Adjustable Motor Bases	29
386-23965-001	Adjustable Motor Base Assembly	Adjustable Motor Bases	30
1620	Gasket, Door, _____" High x _____" Wide	Door	12
TAC01494	Standard Touchup Spray Paint, Dessert Sand	Gasket/Caulk/Adhesive for Solution Units	12
TAC2401012000	Steel Security Chain	Door Chain Assembly	66
TAC2401013000	Bolt Snaps	Door Chain Assembly	66
TAC2401014000	Steel Staple Plate	Door Chain Assembly	66
TAC2401015000	Cold Shuts	Door Chain Assembly	66
TAC3303006000	Fender Washer, .313"	Door Chain Assembly	66

## NOTES

## NOTES



	Form Number: 102.20-RP1 (LS01)	606
	Supersedes: 102.20-RP1 (LS01) (605)	
LITERATURE SUPPLEMENT	File with: 102.20-RP1 (1104)	
Subject: Fastener List and Gasket/Caulk/Adhesive List for Solution Air Handler, Renewal Parts Manual		

General - Replace the Fasteners List on pages 9 and 10 and the Gasket/Caulk/Adhesive list on Pages 11 and 12 with the following charts.

FASTENERS FOR SOLUTION UNITS		
PART NUMBER	Description	WHERE USED
021-01154-000	WASHER, LOCK, INTERNAL TOOTH, 5/16", ZINC PLTD.	RF Filter Tracks
021-01155-000	WASHER, LOCK, INTERNAL TOOTH, 3/8", ZINC PLTD.	Fan Skid, Lifting Lugs
021-01163-000	WASHER, LOCK, INTERNAL TOOTH, 1/2", ZINC PLTD.	Fan Skid
021-01168-000	WASHER, LOCK, INTERNAL TOOTH, 5/8", ZINC PLTD.	Blower Mounting
021-01248-000	WASHER, PLAIN, 5/16" ID x 3/4" OD x 0.065" NOM THK	Blower Mounting
021-01267-000	WASHER, FLAT, 7/16" ID x 1" OD x 0.083" THK, ZINC PLTD.	Snubber
021-01288-000	WASHER, FLAT, 11/16" ID x 1-3/4" OD x 0.134" THK, ZINC PLTD.	Blower Mounting
021-01481-000	SCREW, HEX CAP, 3/8"-16 x 1.0", ZINC PLTD.	Fan Skid
021-01499-000	SCREW, HEX CAP, 3/8"-16 x 1.5", ZINC PLTD.	Blower Mounting
021-02523-000	NUT, HEX, 5/16"-18, ZINC PLTD.	RF Filter Tracks
021-02782-000	SCREW, HEX CAP, 5/16"-18 x 1-1/4", ZINC PLTD.	Blower Mounting
021-02794-000	SCREW, HEX CAP, 5/8"-11 x 2", ZINC PLTD.	Blower Mounting
021-02860-000	NUT, HEX, 1/2"-13, ZINC PLTD.	Fan Skid
021-02862-000	NUT, HEX, 5/8"-11, ZINC PLTD.	Blower Mounting
021-03749-000	SCREW, MACHINE, PHILLIPS ROUND HEAD, 1/4"-20 x 1-1/4", ZINC PLTD.	Blower Mounting
021-05146-000	WASHER, FLAT, 9/16" ID x 1-3/8" OD x 7/64" THK, ZINC PLTD.	Fan Skid
021-08388-000	SCREW, HEX CAP, 1/2"-13 x 1", ZINC PLTD.	Fan Skid, Safety Grade
021-08394-000	SCREW, HEX CAP, 5/16"-18 x 3/4", ZINC PLTD.	RF Filter Tracks
021-08395-000	SCREW, HEX CAP, 3/8"-16 x 3/4", ZINC PLTD.	Secures Block to Motor Base
021-09983-000	WASHER, FLAT, 3/8" ID x 7/8" OD x 0.083" THK, ZINC PLTD.	RF Filter Tracks
021-10186-000	WASHER, LOCK, SPLIT, 1/4"	Blower Mounting
021-11645-000	NUT, RETAINING, 3/8"-16, 0.162"-0.210" PANEL RANGE	Fan Skid
021-12656-000	NUT, HEX, 3/4"-10, ZINC PLTD.	Blower Mounting
021-12917-000	SCREW, HEX, THREAD FORMING, 5/16" x 3/4"	Fan Skid, Coil Supports, Coil Blockoff to Coil Casing
021-13291-000	NUT, RETAINING, 1/4"-20, 0.13"-0.156" PANEL RANGE, ZINC PLTD.	Economizer w/ Angled MA Wall Hatch
021-13656-000	NUT, WELD, 3/8"-16, ZINC PLTD.	Pipe Chase Base Rail
021-13734-000	SCREW, PHILLIPS PAN HEAD, THREAD CUTTING, 1/4" x 1/2", ZINC PLTD.	Hood & Hood Gutter
021-13830-000	SCREW, HEX CAP, 3/4"-10 x 2-1/2", ZINC PLTD.	Blower Mounting
021-13863-000	SCREW, SELF DRILLING, #10-24 x 1/2", ZINC PLTD.	Control Brackets
021-13911-000	SCREW, HEX, THREAD FORMING, 3/8" x 3/4", ZINC PLTD.	Fan Skid, Coil Stacking Splice
021-15802-000	WASHER, FLAT, 13/16" ID x 1-3/4" OD x 0.134" THK, ZINC PLTD.	Blower Mounting
021-16151-000	NUT, HEX, 1/4"-20, ZINC PLTD."	Blower Mounting (Lockwasher - 021-10186-000)

Continued on next page

FASTENERS FOR SOLUTION UNITS (CONTINUED)		
PART NUMBER	DESCRIPTION	WHERE USED
021-17717-000	NUT, HEX LOCK, W/ INTERNAL TOOTH WASHER, 3/8"-16, ZINC PLTD.	Fan Skid
021-17718-000	NUT, HEX LOCK, W/INTERNAL TOOTH WASHER, 1/4"-20, ZINC PLTD.	Blower Mounting, with Lock Washer
021-17722-000	SCREW, PHILLIPS PAN HEAD, THREAD FORMING SHEET METAL, 1/4" x 3/4", ZINC PLTD.	Primary Screw for Inside Sheet Metal, Panels Outside Unit , Damper Mounting, Shipping Tie Down to Raceway
021-17728-000	SCREW, HEX CAP, 1/2"-13 x 1-3/4", ZINC PLTD.	Blower Mounting
021-19515-000	SCREW, HEX, SELF-DRILLING, 1/4"-14 x 3/4", ZINC PLTD.	Fan Discharge Flex Connection
021-19546-000	SCREW, SELF-DRILLING, 1/4"-14 x 1", SS	Self Drill Screw for Various Locations When Required
021-19547-000	NUT, RIVET, KNURLED, 1/2"-13, ZINC PLTD.	Mounting Kit, Large MCC Panel
021-19556-000	SCREW, HEX CAP, FULL THREAD, 1/2"-13 x 9", ZINC PLTD.	Motor Base
021-19558-000	BLOCK, MOTOR BASE, 1/2"-13 & 3/8"-16 THRU HOLES	Motor Base
021-19559-000	SCREW, HEX CAP, 3/8"-16 x 5", FULL THREAD, ZINC PLTD.	Snubber
021-19560-000	SCREW, PHILLIPS PAN HEAD, SELF-DRILLING, 1/4"-14 x 1", ZINC PLTD.	Self Drill Screw for Various Locations When Required
021-19563-000	SCREW, PHILLIPS PAN HEAD, SELF-DRILLING, 1/4"-14 x 1", SS	Self Drill Screw for Various Locations When Required
021-19564-000	SCREW, PHILLIPS PAN HEAD, THREAD CUTTING, 1/4" x 1/2", SS	Hood & Hood Gutter
021-19565-000	SCREW, HEX, SELF DRILLING, 1/4"-14 x 1", ZINC PLTD. W/ZINC PLTD. EPDM WASHER	Roof
021-19567-000	PLUG, 5/64" HEAD DIA., STEEL FINISHING TO FIT 3/4" ID HOLE	Top Corner Connector Foam Hole Plug
021-19568-000	PLUG, 1-41/64" HEAD DIA., STEEL FINISHING TO FIT 1-1/2" HOLE	Corner Connector Lifting Hole Plug
021-19570-000	SCREW, HEX SOCKET, BUTTON HEAD, 3/8"-16 x 3/4", ZINC PLTD.	Lifting Lugs, Corners, Top split, Stacking Plate
021-19571-000	WASHER, LOCK, INTERNAL TOOTH, 3/4", ZINC PLTD.	Blower Mounting
021-19579-000	NUT, RIVET KNURLED, #10-32, ZINC PLTD.	Mounting Kit, Small MCC Panel
021-19580-000	NUT, RIVET KNURLED, 3/8"-16, ZINC PLTD.	Mounting Kit, Large MCC Panel
021-19581-000	SCREW, HEX CAP, 3/8"-16 x 2-1/2", ZINC PLTD.	Mounting Kit, 2KVA Transformer
021-19582-000	SCREW, MACHINE, PHILLIPS PAN HEAD, #10-32 x 1/2", WITH CAPTIVE INTERNAL TOOTH WASHER, ZINC PLTD.	Mounting Kit, 500VA / 150VA Control Transformer & Mounting Kit, Small MCC Panel
021-19586-000	NUT, HEX, 3/8"-16, ZINC PLTD.	Lifting Lugs
021-19587-000	RIVET, POP, 0.19" DIA., 1/4" x 3/8" GRIP, ZINC PLTD.	RF Front or Rear Load Filter Frames (Was P/N 033-05003-606)
021-19588-000	SCREW, HEX CAP, 1/2"-13 x 4", ZINC PLTD.	Base Rail Lifting Lug to Lifting Lug at Split
021-19589-000	RIVET, POP, 0.13" DIA., .19"-.25" GRIP	Panel Outer to Liner
021-19597-000	SCREW, HEX, THREAD FORMING, 5/16" x 3/4", SS	Fan Skid, Coil Supports, Coil Blockoff to Coil Casing
021-19598-000	SCREW, HEX, SELF DRILLING, 1/4"-14 x 3/4", SS	Fan Discharge Flex Connection
021-19599-000	SCREW, PHILLIPS PAN HEAD, THREAD FORMING, 1/4"-14 x 3/4", SS	Primary Screw for Inside Sheet Metal, Panels Outside Unit , Damper Mounting, Shipping Tie Down to Raceway

**FIELD SERVICE PARTS**  
**GASKET/CAULK/ADHESIVE FOR SOLUTION UNITS**

PART NUMBER	DESCRIPTION	WHERE USED
<b>GASKETS</b>		
028-11860-010	Gasket, Neoprene, Closed Cell, 1/2" W x 1/4" Thk	Indoor unit raceway channel (sides, ends & vertical)
028-11873-010	Gasket, Neoprene, Closed Cell, Grey, 3/4" W x 1/4" Thk	Panel to panel (vertical) on flange
028-11864-010	Gasket, Neoprene, Closed Cell, 3/4" W x 1/2" Thk	Between vertical bulkheads and wall panels; between horizontal bulkheads and roof/floor panels
028-11778-010	Gasket, Neoprene, Closed Cell, 1-1/4" W x 1/4" Thk	Shipping split, bottom, sides, top panel to panel ends butt to butt
028-11867-010	Gasket, Neoprene, Closed Cell, 1-1/4" W x 1/2" Thk	Type 8 filter tracks under the bulkhead
028-11880-010	Gasket, Neoprene, Closed Cell, 2" W x 3/16" (.188) Thk	Under roof seam cap, under roof overhang at pipechase, on pipe chase (field applied)
28-11883-010	Gasket, Corner, Neoprene, Closed Cell, 3-1/2" W x 1/4" Thk x 3-1/2" Lg.	XTO shipping splits
028-11791-010	Gasket, Polyurethane, Open Cell, 1" W x 1" Thk	Filters, between roof panels
028-11882-010	Gasket, Foam, Closed Cell, Black, 2-1/2" W x 1/8" Thk	All electrical panels, to seal the conduit penetrations between them and the unit wall panels, intermediate drain pan mounting
AJ4144	Gasket, Door, 12' Lg.	Foam gasket - new cake pan doors (beginning Jan 2006)
AJ3122	Gasket, Door, 500' Roll	Foam gasket - old doors (before Jan 2006)
028-11865-010	Foam, #2 Polyester, Open Cell, 2" W x 2" Thk x 4" Lg.	Wireway at pressure transitions
<b>TAPES</b>		
013-02978-010	Tape, Butyl, 1/2" W x 1/8" Thk	Outdoor unit doors along sides when door is between two panels
013-02979-010	Tape, Butyl, 1/2" W x 1/4" Thk	Outdoor units, between raceway 11/16" flanges and roof
013-02976-010	Tape, Butyl, 3/4" W x 3/16" Thk	Outdoor units, between raceway 11/16" flanges and panels/roof/drain pan/pipe chase/control enclosure, panel to panel (vertical)
013-02977-010	Tape, Butyl, 1-1/2" W x 1/8" Thk	Outdoor units, between top raceways & along roof sides & between bottom raceways & curb rest
028-11879-010	Tape, Stainless Steel, 2" W x 0.004" Thk, 50' Roll	Factory floor seam cap (interior of unit)
028-11879-012	Tape, Stainless Steel, 3" W x 0.004" Thk, 50' Roll	Factory roof seam cap (exterior of unit)
010-02917-000	Ins Therm 1/8" x 1-1/2" x 50', White Ethafoam, Marriage Tape	Coil, bulk head seal

Continued on next page

**FIELD SERVICE PARTS  
GASKET/CAULK/ADHESIVE FOR SOLUTION UNITS**

PART NUMBER	DESCRIPTION	WHERE USED
<b>CAULKS</b>		
013-02966-011	Caulk, Urethane, Gray, Manus-bond, 75-AM 100ZTU (Same as Urethane, Gray, Sikaflex 221)	Corner connectors & raceway; inside corners where corner connector, raceway and panels meet; wireway and bulkhead seal; all shipping splits (interior/exterior)
013-03317-040	Caulk, Urethane, Champagne, Sikaflex 221	Outdoor unit as need to match champagne paint
Field Purchase	Caulk, Urethane, Gray, Loc-tite	Grainger P/N 4KM87
Field Purchase	Caulk, Urethane, Gray	Sikaflex Sealant, P/N 221, Home Depot
<b>FAN FLEX CONNECTION</b>		
013-22013-010	Adhesive, Super Fast	Fan flex connection
026-30458-010	Connector, Duct Fabric, 8", order by the inch	Flex connector for fan transition
026-30548-000	Connector, Duct Fabric, 8", Ventglas, 150' Roll	Flex connector for fan transition
026-30473-010	Connector, Duct Fabric, 10", order by the inch	Flex connector for fan transition
026-30473-000	Connector, Duct Fabric, 10", Ventglas, Plain Fabrics w/o Metal, 150' Roll	Flex connector for fan transition
028-11744-010	Tape, Polyethylene, Double Sided, 1/2" W x 1/32" Thk	Fan flex connection
<b>GROMMETS</b>		
028-11872-000	Grommet, Supply/Return Coil Header, 1/8" PVC, for 1", 1-1/4" and 1-1/2" IPS Connections	Coil header panel, for 1", 1-1/4" and 1-1/2" connections
028-11871-000	Grommet, Supply/Return Coil Header, 1/8" PVC, for 2" and 2-1/2" IPS Connections	Coil header panel, for 2" and 2-1/2" connections
028-11861-000	Grommet, Supply/Return Coil Header, 1/8" PVC, For 3" IPS Connections	Coil header panel, for 3" connections
<b>MISCELLANEOUS</b>		
029-08786-000	Damper Ball Joint	For 5/16" dia. rod x 1/4"-28 TPI mount
044-02912-000	Ultra Flex Elastomeric, #2260-0100 (White) Coating: *an Expiration Date Required for this Product (Drain Pan), 5 Gal.	Mastic coating for drain pan
013-03322-000	Paint, Champagne, 12oz. Spray Can	Production beginning 5/1/05
TAC01494	Standard Touchup Spray Paint, Dessert Sand	Outdoor unit exterior, shipped before 5/1/05



**A JOHNSON CONTROLS COMPANY**

P.O. Box 1592, York, Pennsylvania USA 17405-1592

Copyright © by Johnson Controls 2006

Form 102.20 RP1 (LS01) (606)

Supersedes 102.20 RP1 (LS01) (506)

Subject to change without notice. Printed in USA

ALL RIGHTS RESERVED