

Fuller[®] Heavy-Duty Transmissions TRTS0910 EN-US

October 2007



Powering Business Worldwide

BACKED BY

Roadranger

SUPPORT

Models

FR-11210B	RTLO-14610B	RTLOF-15610B-T2	RTOF-11909MLL	RTX-14709A
FR-12210B	RTLO-14610B-T2	RTLOF-16610B	RTOF-13707DLL	RTX-14709B
FR-13210B	RTLO-14613B	RTLOF-16610B-T2	RTOF-13707MLL	RTX-14709H
FR-14210B	RTLO-14618A	RTLOF-16618A	RTOF-14608LL	RTX-14710B
FR-15210B	RTLO-14713A	RTXF-15615	RTOF-14708LL	RTX-14710C
FR-9210B	RTLO-14718B	RTLOF-16713A	RTOF-14709MLL	RTX-14715
FRF-11210B	RTLO-14913A	RTLOF-16713A-T2	RTOF-14908LL	RTX-15615
FRF-12210B	RTLO-14918B	RTLOF-16718B	RTOF-14909ALL	RTXF-16709H
FRF-13210B	RTLO-14918B-T2	RTLOF-16913A	RTOF-14909MLL	RTX-15710B
FRF-14210B	RTLO-15610B	RTLOF-16913A-T2	RTOF-16908LL	RTX-15710C
FRF-15210B	RTLO-15610B-T2	RTLOF-16918B	RTOF-16909ALL	RTX-15715
FRF-9210B	RTLO-16610B	RTLOF-16918B-T2	RTX-11509	RTX-16709B
FRO-11210B	RTLO-16610B-T2	RTLOF-17610B	RTX-11608LL	RTX-16709H
FRO-11210C	RTLO-16618A	RTLOF-17610B-T2	RTX-11609A	RTX-16710B
FRO-12210B	RTXF-14710C	RTLOF-18610B	RTX-11609B	RTX-16710C
FRO-12210C	RTLO-16713A	RTLOF-18718B	RTX-11609P	RTXF-11509
FRO-13210B	RTLO-16713A-T2	RTLOF-18913A	RTX-11609R	RTXF-11608LL
FRO-13210C	RTLO-16718B	RTLOF-18913A-T2	RTXF-15715	RTXF-11609A
FRO-14210B	RTLO-16913A	RTLOF-18918B	RTX-11610	RTXF-11609B
FRO-14210C	RTLO-16913A-T2	RTLOF-18918B-T2	RTX-11615	RTXF-11609P
FRO-15210B	RTLO-16918B	RTLOF-20913A	RTX-11708LL	RTXF-11609R
FRO-15210C	RTLO-16918B-T2	RTLOF-20918B	RTX-11709A	RTXF-11610
RTXF-14615	RTLO-17610B	RTLOF-20918B-T2	RTX-11709B	RTXF-11615
RTXF-14708LL	RTLO-17610B-T2	RTLOF-22918B	RTX-11709H	RTXF-11708LL
FRO-16210B	RTLO-18610B	RTLOFC-16909A-T2	RTX-11710B	RTXF-11709H
FRO-16210C	RTLO-18610B-T2	RTO-11607L	RTX-11710C	RTXF-11710B
FRO-17210C	RTLO-18718B	RTO-11607L	RTX-11715	RTXF-11710C
FRO-18210C	RTLO-18718B-T2	RTXF-15710B	RTX-12509	RTXF-11715
FROF-11210B	RTLO-18913A	RTO-11607LL	RTX-12510	RTXF-12509
FROF-11210C	RTLO-18913A-T2	RTO-11607LL	RTX-12515	RTXF-12510
FROF-12210B	RTLO-18918B	RTO-11608LL	RTX-12609A	RTXF-16710B
FROF-12210C	RTLO-18918B-T2	RTO-11707DLL	RTX-12609B	RTXF-12515
FROF-13210B	RTLO-20913A	RTO-11707LL	RTX-12609P	RTXF-12609A
FROF-13210C	RTLO-20918B	RTO-11708LL	RTX-12609R	RTXF-12609B
FROF-14210B	RTLO-20918B-T2	RTO-11709MLL	RTX-12610	RTXF-12609P
FROF-14210C	RTLO-22918B	RTO-11908LL	RTX-12709A	RTXF-12609R
FROF-15210B	RTLOC-16909A-T2	RTO-11909ALL	RTX-12709B	RTXF-12610
FROF-15210C	RTXF-14715	RTO-11909MLL	RTX-12709H	RTXF-12709H
FROF-16210B	RTLOF-11610B	RTO-13707DLL	RTX-12710B	RTXF-12710B
FROF-16210C	RTLOF-11610B-T2	RTO-13707MLL	RTX-12710C	RTXF-12710C
RT-7608LL	RTLOF-12610B	RTO-14608LL	RTXF-16709B	RTXF-13609A
RT-8608L	RTLOF-12610B-T2	RTO-14709MLL	RTX-13609A	RTXF-13609B
RT-8908LL	RTLOF-12713A	RTO-14908LL	RTX-13609B	RTXF-13609P
RTF-8608L	RTLOF-12913A	RTO-14909ALL	RTX-13609P	RTXF-13609R
RTF-8908LL	RTLOF-13610B	RTO-14909MLL	RTX-13609R	RTXF-13709H
RTLO-11610B	RTLOF-13610B-T2	RTO-16908LL	RTX-13709H	RTXF-13710B
RTXF-14709H	RTLOF-14610B	RTO-16909ALL	RTX-13710B	RTXF-13710C
RTXF-14710B	RTLOF-14610B-T2	RTOF-11607L	RTX-13710C	RTXF-14608LL
RTLO-11610B-T2	RTLOF-14613B	RTOF-11607LL	RTX-14608LL	RTXF-14609A
RTLO-12610B	RTLOF-14618A	RTOF-11608LL	RTX-14609A	RTXF-14609B
RTLO-12610B-T2	RTLOF-14713A	RTXF-15710C	RTX-14609B	RTXF-14609P
RTLO-12713A	RTLOF-14718B	RTOF-11707LL	RTX-14609P	RTXF-14609R
RTLO-12913A	RTLOF-14913A	RTOF-11708LL	RTX-14609R	RTXF-14610
RTLO-13610B	RTLOF-14918B	RTOF-11709MLL	RTX-14610	RTXF-16710C
RTLO-13610B-T2	RTLOF-14918B-T2	RTOF-11908LL	RTX-14615	
RTLO-14610A	RTLOF-15610B	RTOF-11909ALL	RTX-14708LL	

WARNINGS

 WARNING

Before starting a vehicle always be seated in the driver's seat, place the transmission in neutral, set the parking brakes and disengage the clutch.

 WARNING

Before working on a vehicle, place the transmission in neutral, set the parking brakes and block the wheels.

 WARNING

Before towing the vehicle, place the transmission in neutral and lift the rear wheels off the ground or disconnect the driveline to avoid damage to the transmission during towing.

FOREWORD	1	TRANSMISSION ALIGNMENT	17
TRANSMISSION FUNCTION	2	Concentric Alignment of	
POWER FLOW	4	Transmission to Engine	17
TIMING	5	Worn Housings	17
Front Section	5	Engine Flywheel Housing Pilot	18
Auxiliary Section	5	Engine Flywheel Housing Face	18
COMMON TRANSMISSION COMPLAINTS	6	Flywheel Face	18
Vibration	6	Flywheel Pilot Bore	19
Gear Slipout and Jumpout	7	Transmission Clutch Housing	19
Auxiliary Section	8	DRIVELINE ANGULARITY	20
Hard Shifting	8	Torsional Vibration	20
Heat	9	Taking Readings	21
Noise	9	PREVENTIVE MAINTENANCE	24
Transmission Noise	9	Daily	24
GEARS AND SHAFTS	11	Every 10,000 Miles	24
Clashing	11	Every 20,000 Miles	25
Gear Failures	11	Every 40,000 Miles	26
Manufacturing Marks	11	Every *50,000 Miles	26
Gear Rattle at Idle	12	Fuller® Preventive Maintenance	
Shaft Twist and Fracture	12	Recommendations	26
BEARINGS	14	LUBRICATION	27
Fatigue	14	Proper Lubrication. . .	
Lubrication	14	the key to long transmission life	27
Brinelling	15	TORQUE RECOMMENDATIONS	30
Fretting	15	TROUBLESHOOTER'S GUIDELINE	32
Contamination	15	CONVERSION TABLE	35
Misalignment	16	TOWING OR COASTING	37
Electric Arcing	16		

FOREWORD

The purpose of this publication is to provide basic technical information for servicing and repairing heavy duty truck transmissions. A guide to help the mechanic locate the trouble, analyze the cause, and make the necessary repairs. Emphasis is placed on servicing Fuller twin countershaft transmissions; however, some sections are common to all mechanical transmissions. If more in-depth diagnosis is required, reference can be made to the following publications:

- Air System Troubleshooting Guide
- Understanding Spur Gear Life
- Service Manuals
- Rear Seal Maintenance Guide

These programs and other forms of product service information for Fuller transmissions and components are available on request. You may also obtain Service Bulletins detailing information on product improvements, repair procedures, and other service related subjects by writing to the following address:

EATON
TRANSMISSION DIVISION
Technical Service Department
PO. Box 4013
Kalamazoo, MI 49003

Every effort has been made to ensure the accuracy of all information in this brochure. However, Eaton Transmission Division makes no expressed or implied warranty or representation based on the enclosed information. Any errors or omissions may be reported to Training and Publications, Eaton Transmission Division, PO. Box 4013, Kalamazoo, MI 49003.

TRANSMISSION FUNCTION

The transmission must efficiently transfer the engine's power, in terms of torque, to the vehicle's rear wheels. Torque is the twisting or circular force delivered by the engine's flywheel. The transmission's gear ratios increase or decrease torque depending on the requirements needed to move or start the load. Gearing also increases or decreases speed. The gear ratios are correctly spaced so that the engine will operate in its most efficient RPM range with progressive speed changes.

To meet the vehicle's requirements, the transmission must have ratios low enough to start the vehicle moving, to maintain movement up grades, and to keep engine operating in its peak efficiency range. The transmission, too, must provide an easy method for gear selection.



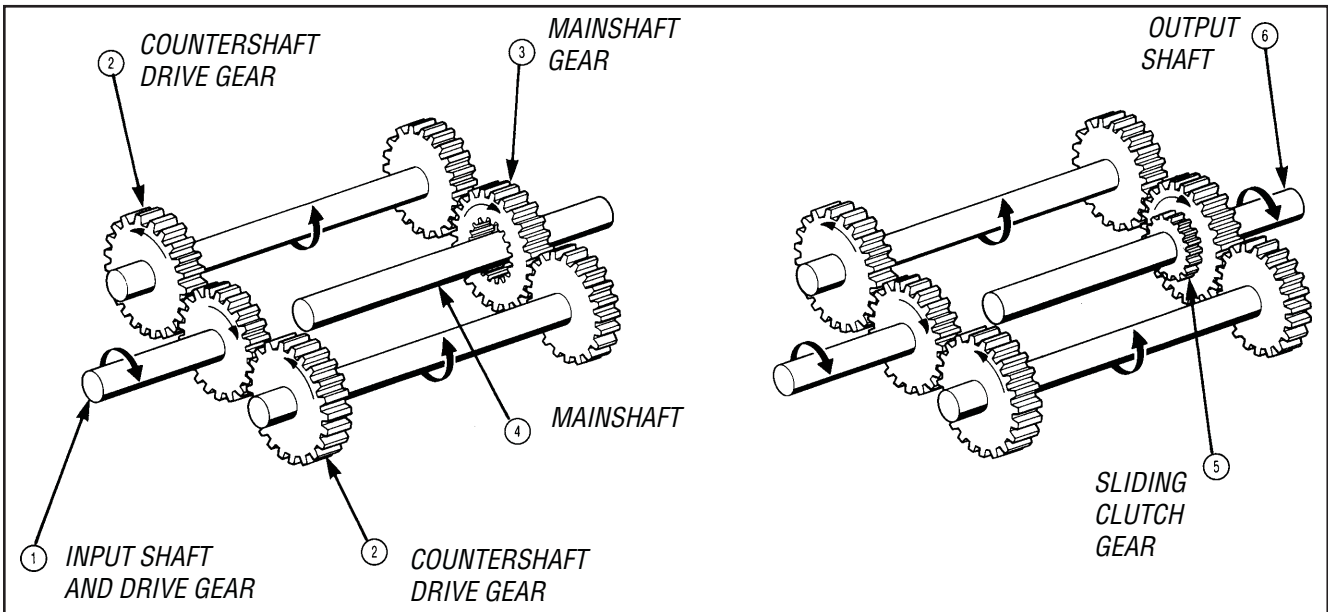

Transmission Function

A simplified diagram of the power flow through a Fuller twin countershaft transmission will help show how torque and speed are changed, and how torque is divided between the two countershafts.

The input shaft and drive gear (1) are in constant mesh with both countershaft drive gears (2); when the input shaft turns, the countershaft gears are in constant mesh with the "floating" mainshaft gears (3). The mainshaft gears are simply free-wheeling on the mainshaft (4). A sliding clutch gear (5), which is splined to the mainshaft, is engaged into the internal clutching teeth of the mainshaft gear, coupling it to the mainshaft. The mainshaft will now be turning at the selected gear ratio.

Fuller twin countershaft Roadranger® transmissions commonly consist of a five speed front section and either a two or three speed auxiliary section, both in one case.

POWER FLOW

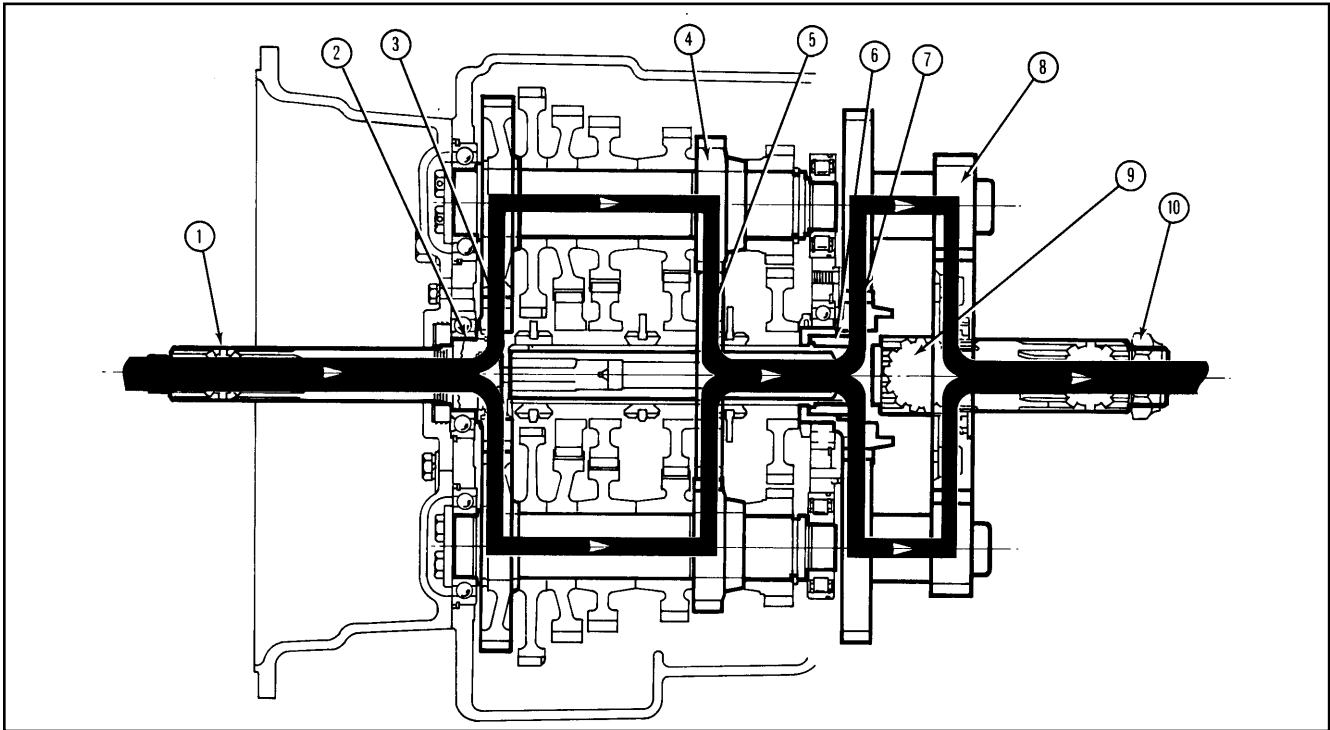

1. Power (torque) from the engine flywheel is transferred to the input shaft.
2. Splines on input shaft engage internal splines in hub of drive gear.
3. Torque is split between the two countershaft drive gears.
4. Torque delivered by two countershaft gears to mainshaft gear which is engaged. Diagram shows first speed gear engaged.
5. Internal splines in hub of mainshaft gear transfers torque to mainshaft through sliding clutch gear.
6. Mainshaft transfers torque to auxiliary drive gear through a self-aligning coupling gear located in hub of auxiliary drive gear.
7. Torque is split between the two auxiliary countershaft drive gears. (In direct drive or high range, power is delivered to the output shaft from the auxiliary drive gear through a self-aligning sliding clutch gear.)
8. Torque is delivered by the two countershaft low range gears to the low range gear.
9. Torque delivered to output shaft through self-aligning sliding clutch gear.
10. Output shaft is attached to driveline.

TIMING

All Fuller twin countershaft transmissions are “timed” at assembly. It is important that proper timing procedures are followed when reassembling the transmission. Timing assures that the countershaft gears will contact the mating mainshaft gears at the same time, allowing mainshaft gears to center on the mainshaft and equally divide the load.

One set of gears must be timed in the front section, and one set the auxiliary section. Timing consists of marking the proper teeth before installation and meshing the marked teeth during assembly. The following is step by step procedure for timing.

Front Section

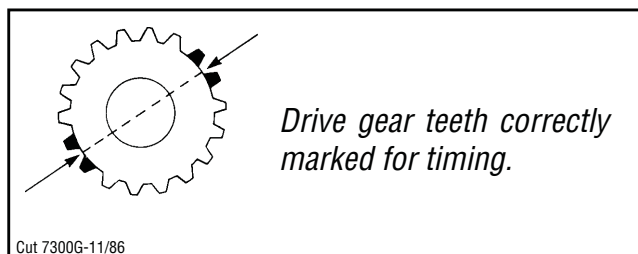

1. Main Drive Gear – Mark any two adjacent teeth on the drive gear, then mark the two adjacent teeth which are directly opposite the first set marked. There must be an equal number of teeth between the markings on each side of the gear.

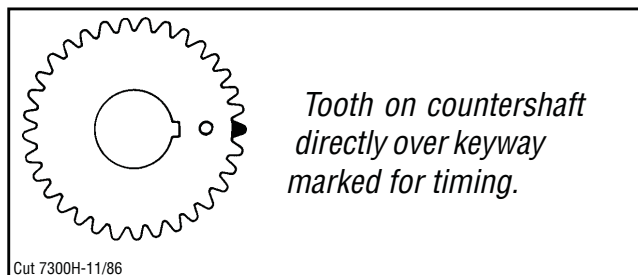

2. Countershaft Drive Gears – Mark on each drive gear the gear tooth which is directly over the keyway. This tooth is stamped with an “O” for identification.

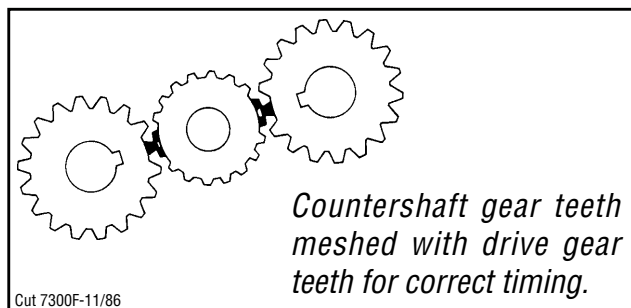

3. Meshing Countershaft Gears and Main Drive Gear – Install the drive gear assembly. Mesh the marked left countershaft gear tooth between the two marked teeth on the drive gear. Repeat the procedure with right countershaft.

Auxiliary Section

The gear set which is marked for timing in the auxiliary section varies, depending on the model. Usually the gear at the rear of the auxiliary is used.

1. Mainshaft Gear – Mark any two adjacent teeth on the mainshaft gear, then mark the two adjacent teeth directly opposite.
2. Countershaft Gears – On each countershaft assembly mark the gear tooth which is stamped with “O”.

Note: Refer to the appropriate service manual for more detailed timing instructions for the Fuller twin countershaft transmission being assembled.

COMMON TRANSMISSION COMPLAINTS

Vibration

Although the effects of vibration will show up in the transmission, vibration usually originates somewhere else in the drive train. Vibration can usually be felt or heard by the driver; however, in some cases, transmission damage caused by vibration will occur without the driver's knowledge. (Refer to the "Torsional Vibration" section for the causes and cures of vibration problems.)

Some Transmission Problems Due to Drive Train Vibration:

1. Gear rattle at idle. (See "Shafts" section.)

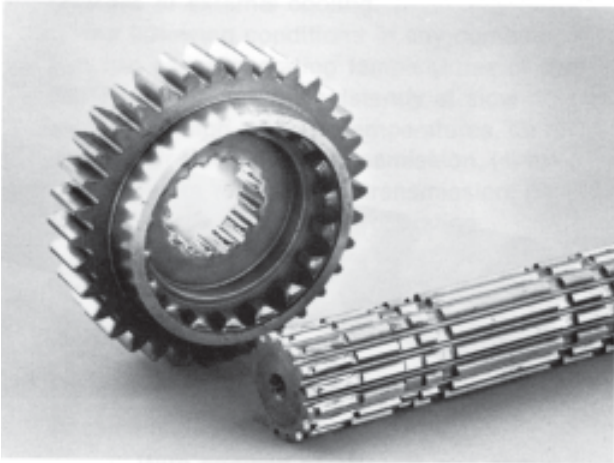

Fretted Splines

2. Gear and shaft splines "fretted".
3. Noise. (See "Noise" section.)
4. Fretted bearings. (See "Bearing" section.)
5. Repeated rear seal leakage. Broken synchronizer pins.

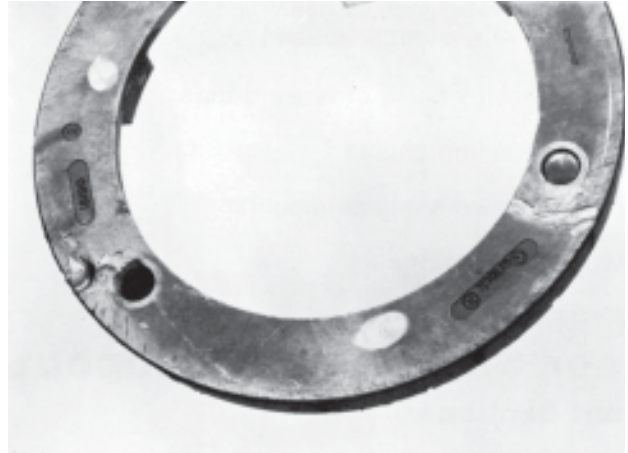

Broken Synchronizer Pins

6. Broken or loose synchronizer pins.
7. Continuous loosening of capscrews, brackets and mountings.



Input Spline Wear

8. Worn shaft spline wear.
9. Worn universal joints. (Not a transmission symptom, but an indicator of vibration.)

Common causes of vibration:

1. Driveline imbalance or misalignment. (See "Transmission Alignment" section.)
2. Unbalanced wheels or brake drums.
3. Rough running engine.
4. Broken or worn engine mounts.
5. Worn suspension.

Gear Slipout and Jumpout

Front Section

When a sliding clutch is moved to engage with a mainshaft gear, the mating teeth must be parallel. Tapered or worn clutching teeth will try to "walk" apart as the gears rotate. Under the right conditions, slipout will result. Some of these conditions are:

1. Transmission mounted eccentrically with engine flywheel pilot.
2. Excessive gear clashing which shortens clutching teeth.

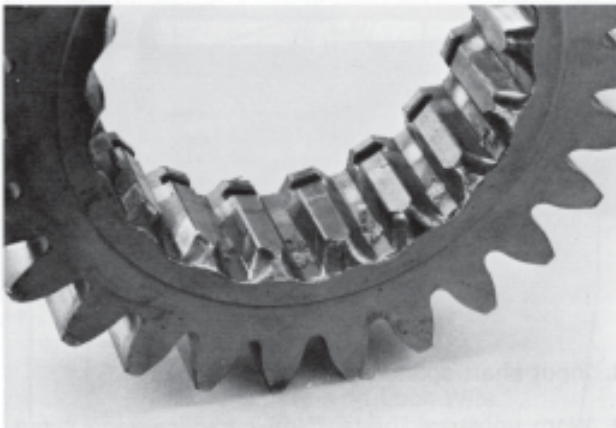

Snubbed Clutching Teeth

3. Gear clutching teeth wearing to a taper.

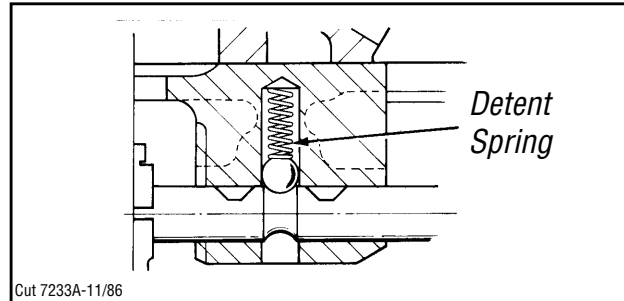

4. Insufficient pressure on detent ball from weak or broken detent spring.

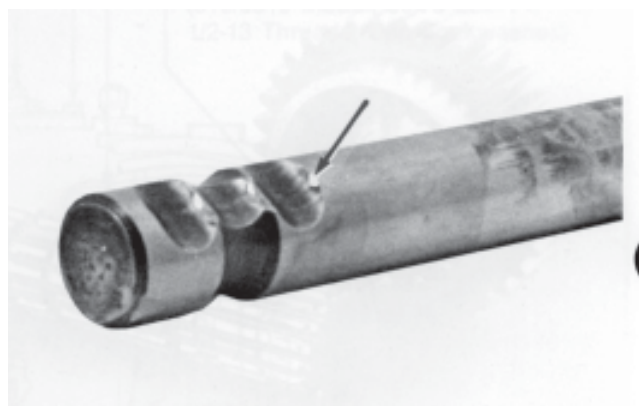

Worn Yoke Bar

5. Excessive wear on detent notch of yoke bar.
6. Incorrect adjustment of remote shift control linkage resulting in partial engagement. Also check for loose connections and worn bushings.

Slipout will generally occur when pulling with full power or decelerating with the load pushing.

Jumpout will occur when a force sufficient to overcome the detent spring pressure is applied to the yoke bar, moving the clutch gear to a neutral position.

Conditions Which May Produce Jumpout

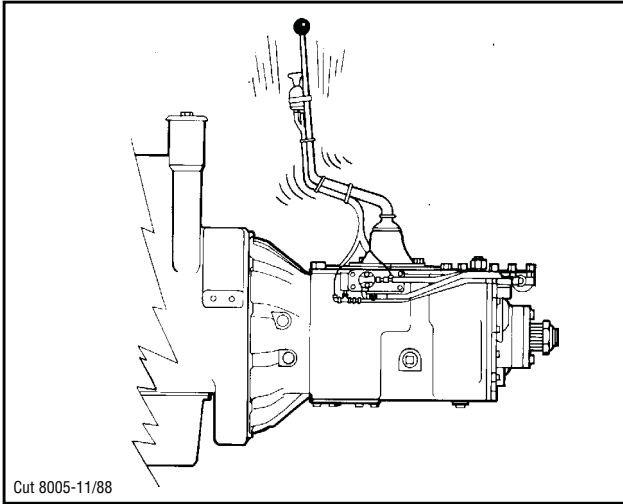

1. Extra heavy and long shift levers which swing, pendulum fashion, from operating over uneven terrain. Whipping action of the lever overcomes detent spring tension.
2. Mechanical remote controls with the master mounted to the frame. Relative movement between engine-transmission package and frame can force transmission out of gear. Worn or broken engine mounts increase the effects of this condition.

Auxiliary Section

Slipout in the auxiliary section may be caused by the clutching teeth being worn, tapered, or not fully engaged. These conditions cause the clutch gear to “walk” out of engagement as the gears turn. Causes of these types of clutching defects are clashing or normal wear after long life. Vibrations set up by an improperly aligned driveline and low air pressure add to the slipout problem.

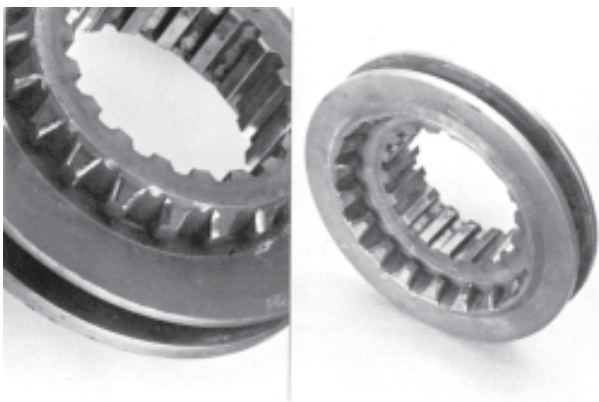

Tapered Clutching Teeth

Jumpout in the auxiliary section usually occurs with the splitter gear set. If torque is not sufficiently broken during splitter shifts, the sliding clutch gear may not have enough time to complete the shift before torque is reapplied to the gears. As torque is reapplied, the partially engaged clutch gear “jumps” out of the splitter gear. Since the gears have torque applied to them, damage will be done to the clutching teeth of the mating gears.

Hard Shifting

The effort required to move a gear shift lever from one gear position to another varies. If too great an effort is required it will be a constant cause of complaint from the driver.

Most complaints are with remote type linkages used in cab-over-engine vehicles. Before checking the transmission for hard shifting the remote linkage should be inspected. Linkage problems stem from worn connections or bushings, binding, improper adjustment, lack of lubrication on the joints or an obstruction which restricts free movement.

To determine if the transmission itself is the cause of hard shifting, remove the shift lever or linkage from the top of the transmission. Then, move the shift blocks into each gear position using a pry bar or screwdriver. If the yoke bars slide easily, the trouble is with the linkage assembly. If the trouble is in the transmission, it will generally be caused by one of the following:

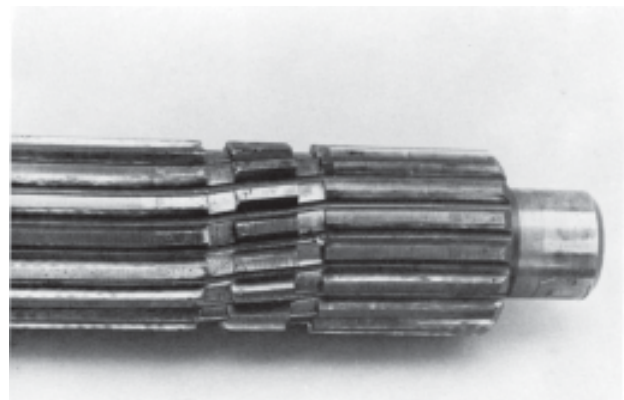

1. Splines of sliding clutch gear binding on mainshaft as a result of a twisted mainshaft key, bent shift yoke or bowed mainshaft key.
2. Yoke bars binding in the bar housing as a result of cracked housing, over-torqued shift block lock-screw, sprung yoke bar, or swelled areas of the yoke bar.

If hard shifting occurs only in first and reverse, the shift block detent plunger movement may be restricted. This can result from burrs on the plunger, or from overtightening the plunger spring plug. With the plunger blocked in the depressed position, the plug should be tightened until it bottoms out against the spring, then backed out 1/4 to 1/2 turn.

Gear clashing should not be confused with hard shifting. Gear clashing occurs when an attempt is made to engage the clutch gear before it has reached synchronization with the mainshaft gear. (See "Clashing", this section.)

Heat

The transmission operating temperature should never exceed 250°F (120°C) for an extended period of time. If it does, the oil will breakdown and shorten transmission life.

Because of the friction of moving parts, transmissions will produce a certain amount of heat. In most cases normal operating temperature is approximately 100°F (40°C) above ambient. Heat is dissipated through the transmission case. When conditions prevent the proper dissipation of heat, then overheating occurs.

Before checking for possible causes of overheating, the oil temperature gauge and sending unit should be inspected to make sure they are giving correct readings.

Causes of Overheating (See also "Lubrication")

1. Improper lubrication. Oil level too low or too high, wrong type of oil, or an operating angle of more than 12 degrees.
2. Operating consistently under 20 MPH.
3. High engine RPM.
4. Restricted air flow around transmission, due to transmission being "boxed in" by frame rails, deck lids, fuel tanks and mounting brackets, or by a large bumper assembly.
5. Exhaust system too close to transmission.
6. High ambient temperature.
7. High horsepower, overdrive operation.
8. Coasting downhill with the clutch depressed.

In some cases an external oil cooler kit can be used to correct overheating problems.

Transmission Oil Coolers are:

Recommended

- With engines of 350 H.P. and above with overdrive transmissions

Required

- With engines 399 H.P. and above with overdrive transmissions and GCWs over 90,000 lbs.
- With engines 399 H.P. and above and 1400 Lbs.-Ft. or greater torque
- With engines 450 H.P. and above

Noise

There will always be a certain level of noise due to normal transmission operation. However, excessive noise, or unusual noise such as whine, growl, or squeal indicates some kind of a problem.

The transmission itself can be the cause of excessive or unusual noise. Also noise can originate elsewhere in the vehicle, but be picked up and amplified by the transmission.

Transmission Noise

1. Knocking or Thudding

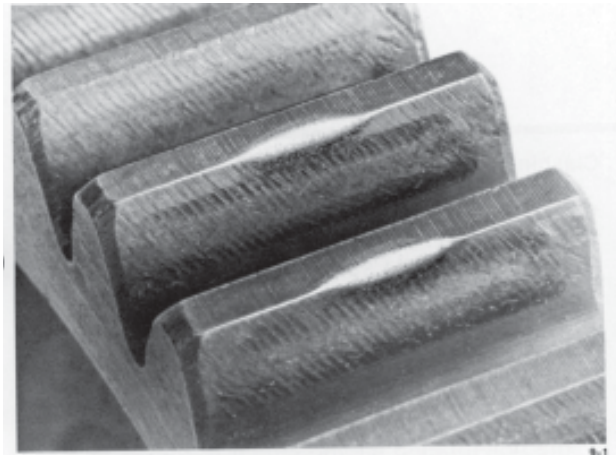

- a. Gears – Bumps or swells on gear teeth. Such bumps or swells can be removed with a hone or small hand grinder; these areas can be identified as highly polished spots on the face of the gear tooth. Generally, this noise is more prominent when the gear is loaded; thus, the problem gear can be located as the noise occurs in a specific gear position. Bumps or swells are caused by

improper handling of gears before or during assembly.

- b. Bearings – Noise comes in at low shaft speeds in any position. It is caused by bearings with damaged balls or rollers, or with pitted and spalled raceways. (See “Bearings” section.)



- c. Cracked Gear – A gear cracked or broken by shock loading or by pressing on shaft during installation will produce this sound at low speeds. At high speeds a howl will be present.

2. High Pitched Whine or Squeal

- a. Gear Wear – Result of normal gear wear, including gear tooth pitting from excessive use. In advanced deterioration, a howl will result.
- b. Mismatched Gear Sets – Such gear sets are identified by an uneven wear pattern on the face of gear teeth.
- c. Bearings – “Pinched” bearings, having insufficient axial or radial clearance. (See “Bearing” section.)

3. Growling

- a. Timing Error – Improper timing of the transmission during reassembly, or improper timing due to gear turning on the countershaft. Both conditions produce error in tooth spacing.

Causes of Transmission Noise Originating Elsewhere in Vehicle (see also “Alignment” section)

1. Rough idling engine. (See “Gears and Shafts” gear rattle.)
2. Engine operating noise.
3. Clutch driven plates in which the dampening action of springs or rubber blocks has been eliminated by wear set or fracture.
4. Driveline out of balance.
5. Unequal joint working angles.
6. Worn crosses in universal joints.
7. Loose or worn center bearings.
8. Worn or pitted teeth on ring gear and pinion of driving axle.
9. Rear axle bearing failure.
10. Wheels out of balance.
11. Worn spring pivot bearing.
12. Loose “U” bolts.
13. Brake drums warped or out of balance.

GEARS AND SHAFTS

Clashing

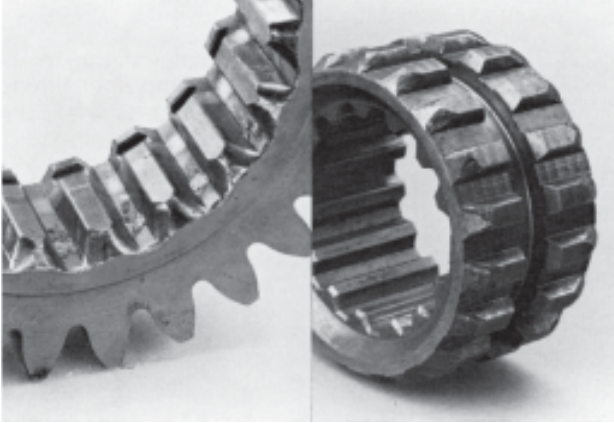

Snubbed Clutching Teeth

Snubbing and clashing gears while shifting are frequent abuses to which unsynchronized transmissions are subjected. Light snubbing will do little damage. The real damage is done by the hard clash shift caused by engaging gears which are far out of synchronization. This can break pieces of metal from the ends of the clutching teeth.

Clashing gears can be traced to one of three causes:

1. **Improper shifting** – This applies to drivers who are not familiar with the shift pattern or have not learned the RPM spread between shifts.
2. **Clutch** – Clashing when starting up in first or reverse gear can be caused by insufficient clutch clearance or a dragging clutch not releasing properly. This makes the transmission countershafts and mainshaft gears continue rotating while the clutch pedal is depressed. Clashing results when the non-rotating sliding clutch is forced to mesh with a rotating mainshaft gear. Double clutching during lever shifts will also reduce snubbing and clashing.
3. **Inertial Force** – Countershafts and mainshaft gears usually take from 3 to 5 seconds to stop rotating after the clutch has been disengaged. Attempting to mesh a clutch gear with a mainshaft gear before the mainshaft gear stops will result in clashing. If the transmission is not equipped with a clutch brake or countershaft brake, it is necessary to pause a few seconds after depressing the clutch pedal before attempting initial engagement of the transmission.

Gear Failures

All gear teeth wear because of the sliding action which takes place as mating teeth mesh. Normal wear is a constant and slow wearing of the tooth surface. Transmission gear tooth life can be shortened by various adverse conditions. These conditions and the failures resulting from them are discussed in the Fuller booklet entitled "Understanding Spur Gear Life" (form no. 186).

Manufacturing Marks

Sometimes gears are replaced or thought to be defective because of marks left on the gear by manufacturing processes. These blemishes, however, do not contribute to gear failure and the gear should not be replaced because of these marks.

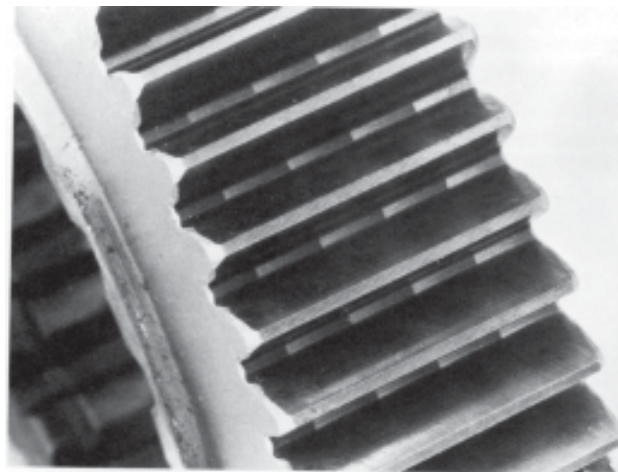

1. **Hob Marks** – These are cutting marks or lines formed during the initial cutting of the gear teeth. Hob marks on the tooth face will be removed by the shaving process, but hob marks in the root of the tooth will most likely remain, and may be found even on gears with much wear on them.

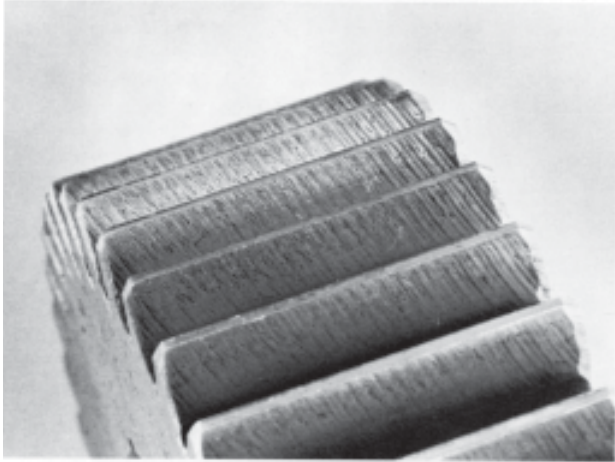

2. **Shaving Marks** – The shaving operation leaves distinct diagonal marks on the face of the gear tooth. These marks can be distinguished from scoring marks by the fact they are diagonal, while scoring marks are more nearly vertical. Most shaving marks are removed during normal gear operation.

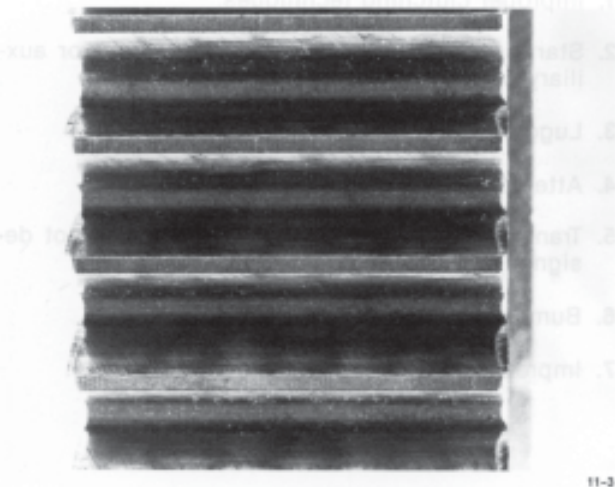

3. **Lipping** – Lipping or shaving burrs, is the formation of “lips” at the tip of the gear teeth machining. These “lips” will do no harm to the gear.

Gear Rattle at Idle

Mainshaft gears are designed to have a specified amount of axial clearance which allows them to rotate freely on the mainshaft. The amount of clearance is governed by the use of washers. A rough idling engine can set up vibrations, causing the mainshaft gears to rattle as they strike mating gears. This condition can usually be cured by improving the idling characteristics of the engine. Tolerance washers may have to be changed to bring the axial gear clearance to within tolerance on high mileage units.

See the service manual for procedure and specifications.

Shaft Twist and Fracture

Failure of transmission shafts through fracturing or twisting is caused when stresses are imposed on them which are greater than they were designed to withstand. The main causes for these failures are:

1. Improper clutching techniques.
2. Starting in too high of gear (either front or auxiliary section).
3. Lugging.
4. Attempting to start with brakes locked.
5. Transmission used for application it was not designed to withstand.
6. Bumping into dock when backing.
7. Improper mounting of adjustable 5th wheel.

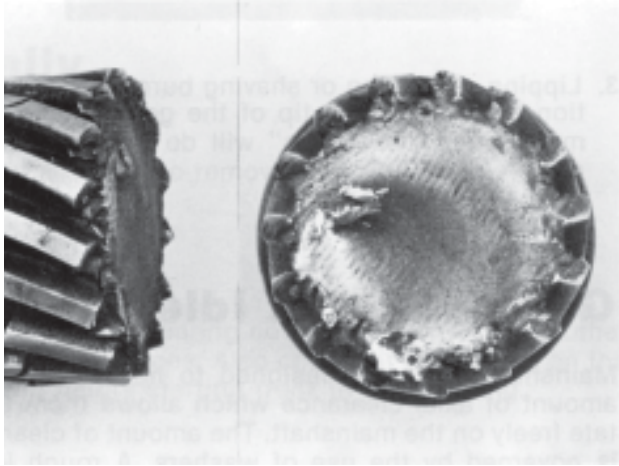

Fractured Mainshaft

As with gear teeth, shafts may fracture as a result of fatigue or impact.

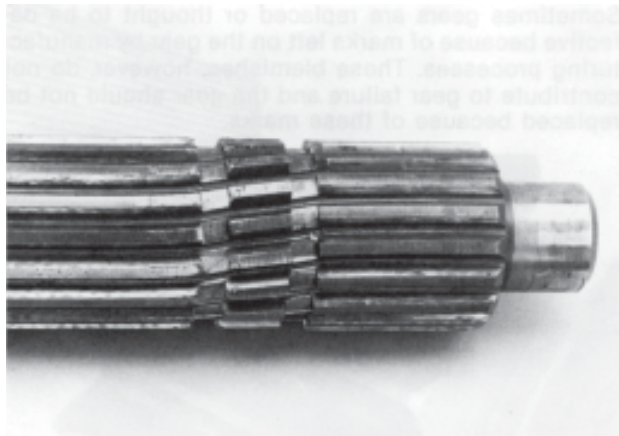

Twisted Mainshaft

Loads not severe enough to cause shaft fractures may cause the shaft to twist.

BEARINGS

Fatigue



Bearing Race "Flaking"

Bearing fatigue is characterized by flaking or spalling of the bearing race. Spalling is the granular weakening of the bearing steel which causes it to flake away from the race. Because of their rough surfaces, spalled bearings will run noisy and produce vibration.

Normal fatigue failure occurs when a bearing "lives out" its life expectancy under normal loads and operating conditions. This type of failure is expected and is a result of metal breakdown due to the continual application of speed and load.



Ball Path Pattern Caused by Out-of-Round Squeeze

Premature fatigue failure may occur in transmissions when the bearing bore is undersized or out of round due to poor quality resleeving. Extreme care should be taken when reboring the housing. Boring the housing off center will result in misalignment of the shafts. Always use precision equipment such as a jig boring machine. Never prick punch the bearing bores to tighten the fit.

Lubrication



Burnt and Spalled Bearing

Bearing failure due to poor lubrication is characterized by discoloration of the bearing parts, spalling of the race, and possible breakage of the retainer. Failure may result not only from a low oil level, but also from contaminated oil, improper grade oil, or mixing of oil types (including the use of additives).

To prevent this type of failure, the transmission should always be filled to the proper level, using a recommended type and grade of oil, and changed at regular intervals. (See "Lubrication" section.)

Brinelling

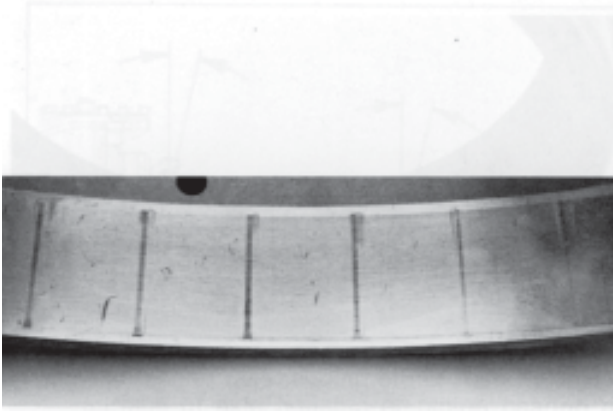

Brinelled Race

Brinelling can be identified as tiny indentations high on the shoulder or in the valley of the bearing raceway. They can be caused by improper bearing installation or removal. Driving or pressing on one race, while supporting the other is the primary cause. To prevent brinelling always support the race which has pressure applied to it. In addition to brinelling, damage can also occur to the bearing shields, retainers and snap rings by using a hammer and chisel to drive bearings. This damage can be avoided by using correct drivers or pullers.

Fretting

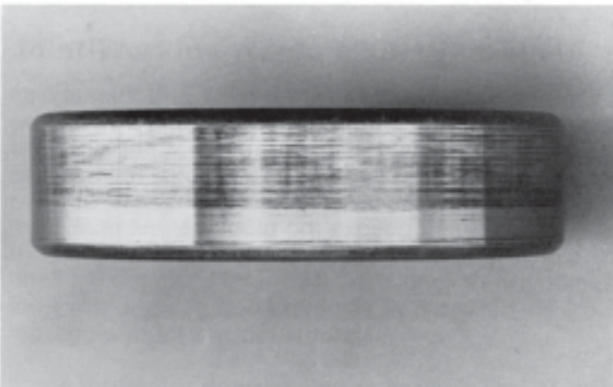

Fretted Outer Race

The bearing outer race can pick up the machining pattern of the bearing bore as a result of vibration. This action is called fretting.

Many times a fretted bearing is mistakenly diagnosed as one which has spun in the bore. Only under extreme conditions will a bearing outer race spin in the bore.

Contamination

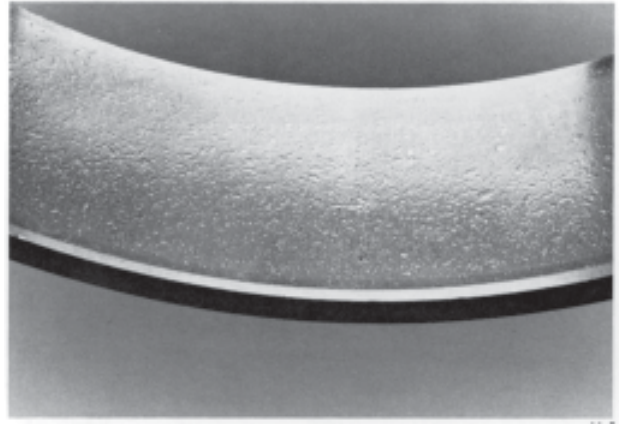

Contaminated Race

When bearings fail as a result of contamination, it is due to either contaminants entering the transmission case or the bearings have been improperly handled during service or storage. Bearings affected from contamination are identified by scoring, scratching or pitting of the raceways and balls or rollers, or a build up of rust or corrosion on the bearing parts. In addition, the presence of very fine particles in the oil, such as abrasive dust, or the use of overly active EP (extreme pressure) oils, will act as a lapping compound and produce a very highly polished surface on the raceways and balls or rollers. This lapping process will significantly shorten the life of the bearing.

Impurities will always enter the transmission during its normal breathing process. This will not seriously affect the bearings if the transmission oil is changed as recommended.

New bearings should be stored in their wrappers until ready for use. Used bearings should be thoroughly cleaned in solvent, light oil or kerosene, covered with a coat of oil and wrapped until ready for use. Always use a new wrapping after reoiling.

Misalignment

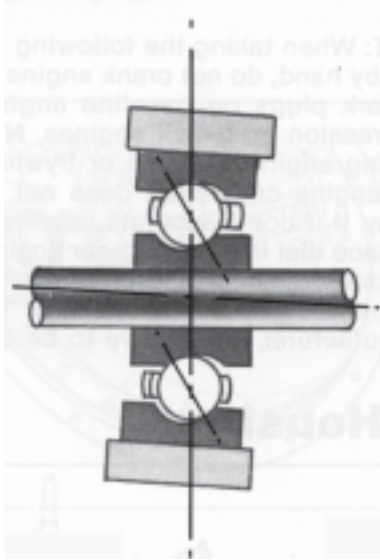

Bearing Misalignment

Misalignment can occur in the input shaft drive gear bearing if the transmission is mounted eccentrically with the pilot bearing bore in the flywheel. An indication of this condition would be damage to the ball separators and shield.

The clutch housing, clutch housing mounting face, and pilot bearing should be checked for eccentricity, foreign matter and proper mounting position when trying to locate the cause of the misalignment. (See "Alignment" section.)

Electric Arcing

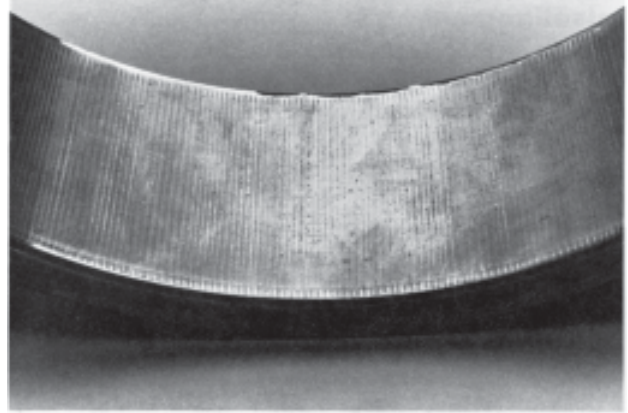

Electric Arcing

When an electric current passing through a bearing is broken at the contact surfaces of the ball or roller and races, arcing results, which will pit the bearing components. In extreme cases, the balls or rollers may actually be welded to the bearing races, preventing the bearing from rotating.

This condition may occur in truck transmissions as a result of electric welding on the truck with an improper ground. When doing either A.C. or D.C. welding, never place the ground so as to allow current to pass through the transmission.

TRANSMISSION ALIGNMENT

Concentric Alignment of Transmission to Engine

Common Concerns Resulting from Misalignment

- Direct gear slipout
- Drive gear bearing failure
- Premature input shaft spline wear from rear hub of two plate clutches

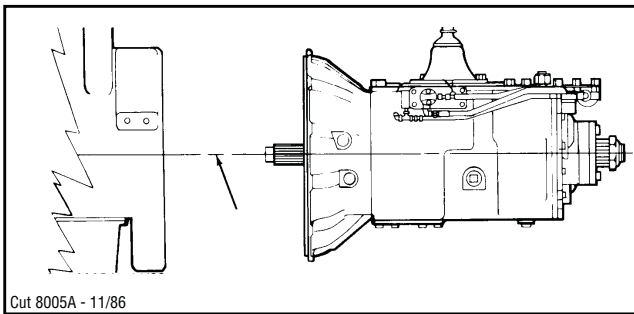

Concentric alignment means that the engine and transmission must have a common axis. The purpose of this section is to set forth the procedures to use in checking for possible misalignment.

The basic instrument needed for taking readings is a taper pointed dial indicator. Accuracy of readings is essential for correcting alignment problems. Clean all surfaces thoroughly before proceeding.

▲ IMPORTANT

When taking the following readings, rotate engine by hand, do not crank engine with starter. Remove spark plugs on gasoline engines, and release compression on diesel engines.

Note: Before dial indicating engine flywheel or flywheel housing, make sure engine crankshaft does not have excessive end-play. If it does, accurate readings cannot be obtained. Place dial indicator finger against flywheel. Force crankshaft back and forth with pry bar. If end-play movement exceeds maximum as specified by engine manufacturer, it will have to be corrected.

Worn Housings

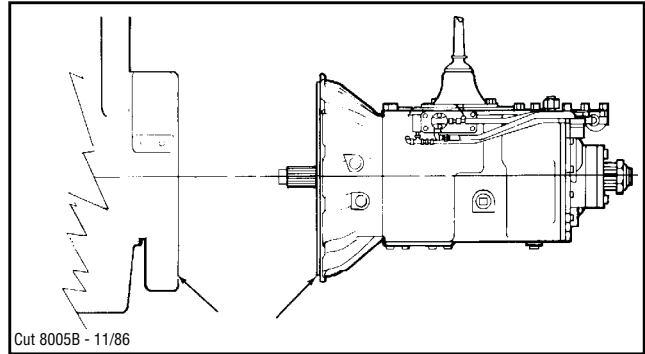

Inspect for worn or fretted pilot on both the transmission clutch housing and the engine flywheel housing. The 1/4" pilot lip of transmission clutch housing can wear into the flywheel housing either by transmission loosening up or after high mileage just from road and engine vibration. Any appreciable amount of wear on either part will cause misalignment and the part should be replaced.

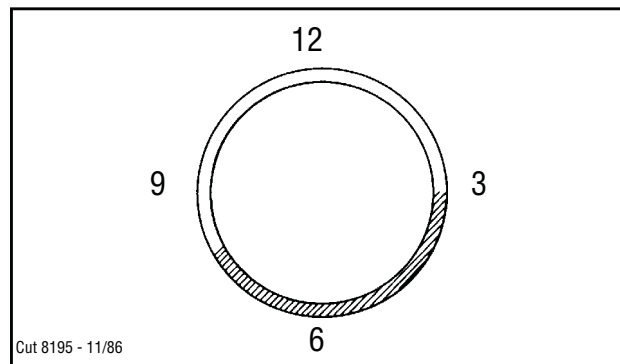

The wear will generally be found from the 3:00 o'clock to 8:00 o'clock position.

Engine Flywheel Housing Pilot

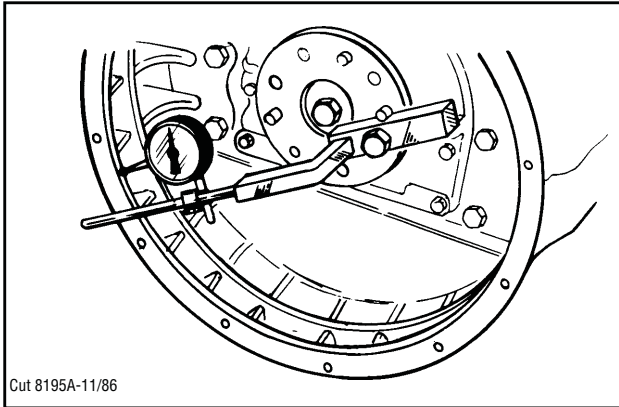

Cut 8195A-11/86

Dial indicate the pilot or bore of engine flywheel housing. Secure dial indicator to engine flywheel with tapered point against housing pilot. Rotate flywheel by hand. With chalk or soap stone, mark high and low points of indicator as it is being rotated.

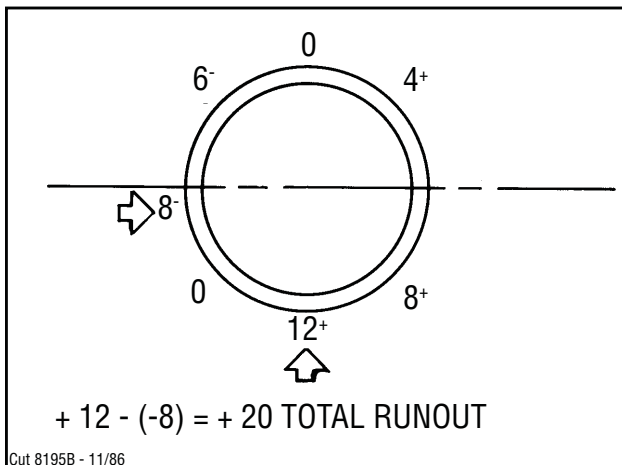

Cut 8195B - 11/86

The total runout will be the difference between the highest plus and minus readings. SAE maximum total runout for flywheel housing pilot is .008" with No.1 and No.2 SAE housings.

Engine Flywheel Housing Face

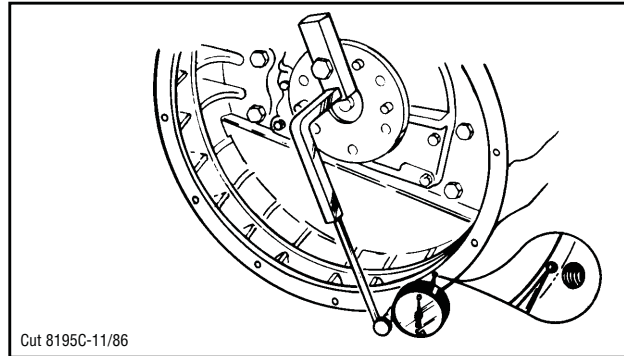

Cut 8195C-11/86

Dial indicate the face of engine flywheel housing. With dial indicator secured to flywheel, move tapered point to contact face of flywheel housing.

Mark high and low points in the same manner as in previous step. SAE maximum total runout for the flywheel housing face is .008" with SAE No.1 and No. 2 housings.

Note: Mark the high and low runout readings in clock positions if it is necessary to reposition the flywheel housing.

Flywheel Face

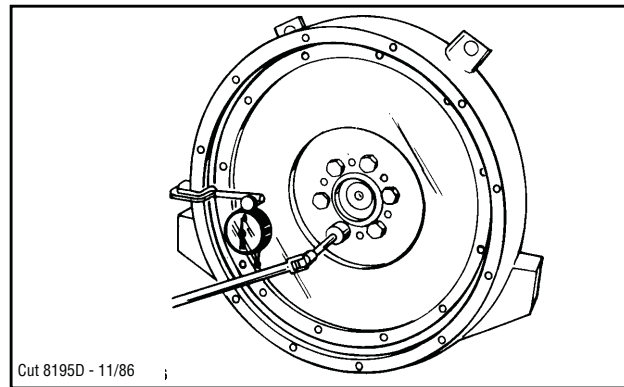

Cut 8195D - 11/86

Dial indicate the flywheel face. Secure dial indicator to engine flywheel housing near the outer edge. Turn flywheel to obtain readings. Maximum allowed is .001" runout or face wobble per inch of flywheel radius. For example, if vehicle has a 14" clutch and readings are taken just off the outer edge of the clutch disc wear, maximum tolerance would be .007".

Flywheel Pilot Bore

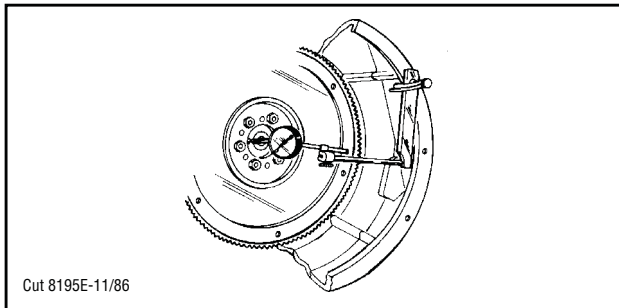

Dial indicate pilot bearing bore of flywheel. With indicator secured to flywheel housing, move gauge finger to contact pilot bearing bore surface. Turn flywheel and obtain readings. SAE maximum total runout for the pilot bearing is .005".

Transmission Clutch Housing

The transmission clutch housing face and pilot can not be checked accurately in the field without special measuring tools. Recommended maximum runout for the transmission clutch housing face and pilot is .003" with SAE No.1 and No.2 housings.

DRIVELINE ANGULARITY

Torsional Vibration

Checking Driveline U-Joint Operation Angles

The action of a driveline with a universal joint at either end working through an angle results in a peculiar motion. The driveline will speed up and slow down twice for each revolution. If the working angles at either end of the shaft are unequal, torsional vibration results. This torsional vibration will tend to cancel itself out if both joint working angles are equal.

Types of Noise

Noise or vibration which occurs only at certain road speeds and diminishes as speed increases is generally caused by unequal working angles of driveline joints.

Noise or vibration which is persistent throughout the speed range and varies in intensity with change of speed may be caused by unbalanced drivelines, unbalanced brake drums or discs, or drivelines with universal joints out of phase.

Preliminary Checks

Make checks of the following before taking angle readings:

1. Check companion flange or yoke nut for looseness and torque to proper specification if necessary.

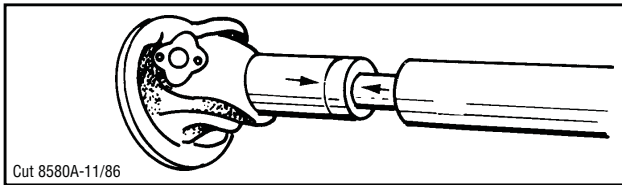

2. Driveline slip joints that do not have the arrows or other markings pointing to each other will result in the driveline universal joints being out of phase. In other words, the transmission universal joint may be turned one spline or more to the right or left of being aligned with the universal joint at opposite end of the driveline.

Note: Some computer designed drivelines are purposely built with U-joints out of phase. Check manufacturer's specifications for proper setting. Also, check closely to make certain no twist has occurred to the tubing, causing these two joints to be out of phase

Make sure the slip joint works freely and is not bound or seized. Slip joints must absorb axle housing movements.

3. Unbalanced drivelines can cause vibration that occurs throughout the speed range of vehicle and varies in intensity with change of speed. The driveline may be at fault in respect to balance and concentricity. A quick field check to determine driveline balance can be made by securing a small piece of metal or similar weight with a hose clamp to the front of the tube where the splined shaft is welded. Road test the vehicle and continue to move the weight around tube until balance point is found and vibration disappears, or is minimized.

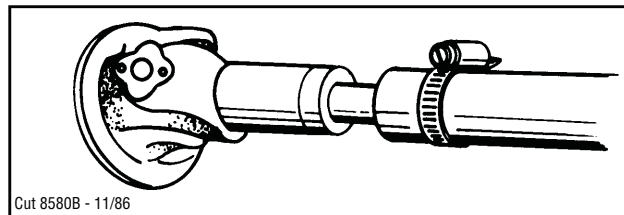

Drivelines are dynamically balanced to their intended rotational velocity and not to infinite speeds. Thus, vibration can be expected when this rotational velocity is exceeded.

Check concentricity of driveline by mounting on lathe centers and dial indicating. Check manufacturer's specifications for runout allowance.

4. Engine supports that are worn, broken or loose, and mounting pads that are worn or deteriorated must be corrected to restore the engine suspension to its original vibration tolerance.

Taking Readings

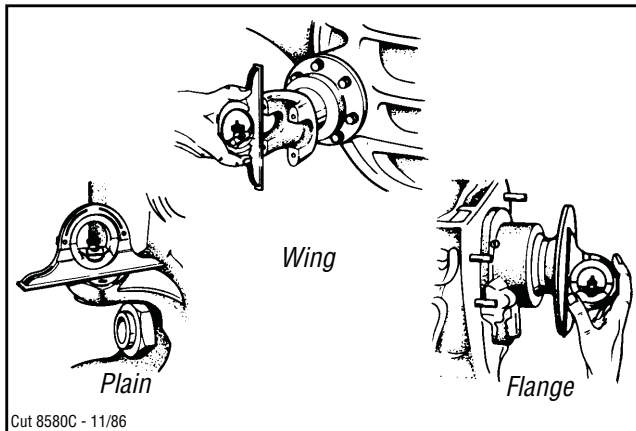

Take readings with protractor from machined surfaces of yokes or companion flanges. Plain, wing or flange type joints may be encountered. Some will require partial disassembly to obtain accurate readings.

On plain type joints, it may be necessary to remove the bearing cap. When taking readings, make sure the universal joint is in a vertical plane.

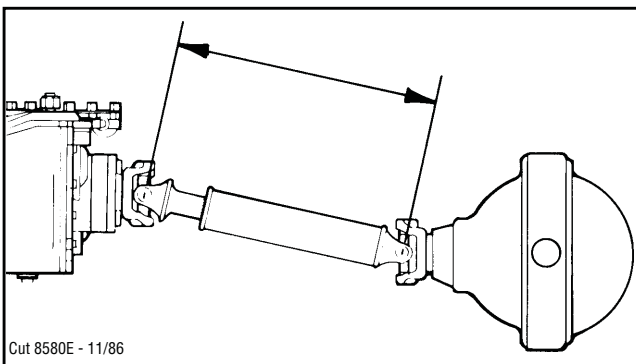
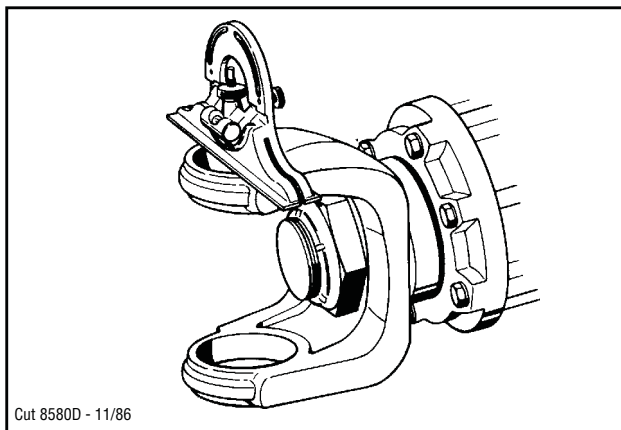

At the rear axle, take readings from a machined surface differential carrier that is in the same plane as the axle pinion shaft, or from machined surface that is perpendicular to pinion shaft, whichever is easier.

If vibration occurs while operating empty, take readings in empty condition. If it occurs when loaded, take readings when loaded.

When it is necessary to measure driveline lengths, measure from joint center to joint center.

Limits

Manufacturer's specifications should be followed when making initial angularity check. Some manufacturers have found it necessary to vary from the ideal due to geometrical limitations. If vibration persists after adhering to manufacturer's specifications, contact the manufacturer's representative.

Angularity Checks – Parallel Flanges or Yokes

1. Single Axle Vehicles
 - a. Transmission angle. Take reading of transmission angle. This angle is the angle to which the rear axle joint angle must match. The transmission angle will have a declination reading of from 0 to 5 degrees in most cases.

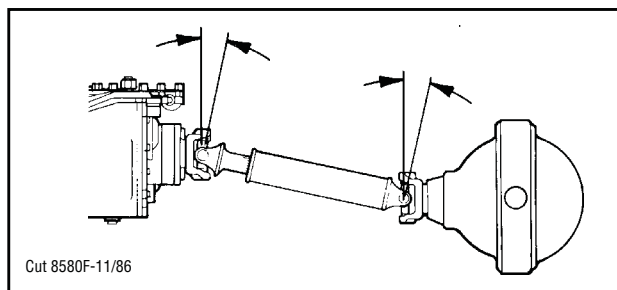

- b. Axle angle. Take reading either from machined surface of axle housing or pinion bearing retainer. **This angle must be within one degree of the transmission angle.**
 - c. Example: If transmission angle reading is 3 degrees down to the rear, the rear axle angle should be 3 degrees up.
2. Tandem Axles or Vehicles with Auxiliary Units
 - a. Take transmission angle reading.
 - b. Take reading from joint of front tandem axle or auxiliary joint. **This reading should be within one degree of transmission angle.**

Note: The rear joint of front tandem axle will be the same as the front joint.

- c. Take reading of joint angle at tandem rear axle, or axle to rear of auxiliary. **This angle must be within one degree of transmission angle.**

Joint Working Angle Limits (Parallel)

Universal joints have a maximum working angle, depending on type and manufacture. It is recommended that the joint working angle for parallel joint assembly not exceed 8 degrees for main drivelines over 40" long. For main drivelines under 40" the maximum angle should not exceed Length (L) divided by 5. (This limit does not apply to interaxle drivelines.)

Example: For a 35" driveline, the maximum joint working angle would be 35 plus 5 or 7degrees. This working angle must not be exceeded.

Place protractor on driveline to obtain angle of driveline from transmission to axle. The difference between the driveline angle and the joint angle is the joint working angle. For instance, if the transmission is 3 degrees down, and the driveline angle is down 7 degrees, the transmission joint working angle is 7 minus 3 or 4 degrees.

On tandem drive or auxiliary installations, take readings in the same manner, comparing the universal joint angles to the driveline angle to which it is attached.

Angularity Checks – Non-Parallel Compensating Angles or Flanges or Yokes

With short wheel base vehicles which have a minimum driveline length from transmission to axle, the driveline is required to operate through very severe working angles on some installations. This also applies to interaxle drivelines. These severe joint working angles induce vibration.

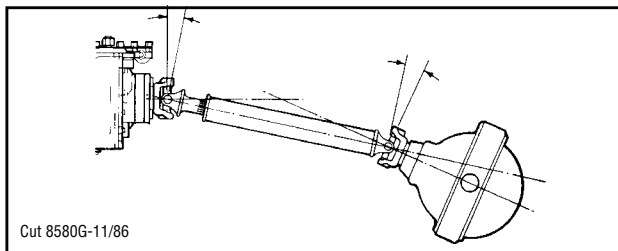

To decrease working angles, the axle is tilted upward until the pinion shaft centerline and transmission mainshaft centerline intersect midway between the joint centers.

With tandem drive axles, the rearward axle is tilted upward until its pinion shaft centerline and forward axle pinion shaft centerline intersect midway between joint centers.

When figuring non-parallel joint installations, it is necessary to take the driveline angle readings as well as transmission and axle angle readings.

1. Single Axle Vehicles

- a. Take angle reading of transmission.
- b. Take angle reading of driveline.
- c. Take angle reading of axle joint.
- d. To compute for correct angles:

(1) The difference between the driveline angle and the transmission angle will be the transmission joint working angle.

(2) The difference between the driveline angle and the axle angle will be the axle joint working angle.

(3) The two working angles of transmission and axle must be equal.

e. Example:

Transmission is 3 degrees down.

Driveline is 7.5 degrees down.

Rear axle is 12 degrees down.

Thus 7.5 minus 3 equals 4.5 degrees.

12 minus 7.5 equals 4.5 degrees, giving 4.5 equal working angles.

2. Tandem Axles or Vehicles with Auxiliary Units

When taking readings on tandem drive axles or between auxiliary and rear axle, the same principles apply as with single axle vehicles. Take readings between transmission and front tandem axle, or auxiliary. Take readings between axles or between auxiliary and axle. In other words, take angle readings for each set of universal joints

Joint Working Angle Limits (Non-Parallel)

It is recommended that the maximum joint working angle for non-parallel joint assemblies not exceed the main driveline length divided by 10. For example, if the main driveline length is 55, the maximum joint working angle is 55 divided by 10 or 5.5 degrees. (This limit does not apply to interaxle drivelines.)

Axle Adjustments

Axle angles may generally be adjusted by one of the following ways, depending on the type of axle.

1. Adjust torque rods, if adjustable type.
2. Add to or reduce length of non-adjustable torque rods.
3. Add or reduce the number of shims behind torque rod brackets.
4. Use correct amount of wedge shims under spring to axle pad.

Suspensions – Pinion Shaft Angle

There will be little or no change of axle pinion angle with types of suspensions which have a parallelogram movement. These allow differential housings to move up and down in a straight vertical during operation.

Suspensions not having a parallelogram movement will allow axle pinion shaft to oscillate in an arc, thereby constantly changing pinion shaft angle during operation. A varying amount of vibration can occur caused by working angles of the universal joints being momentarily unequal.

Single drive axle vehicles have little or no change of axle pinion angle during operation.

PREVENTIVE MAINTENANCE



A good Preventive Maintenance (PM) program can avoid breakdowns, or reduce the cost or repairs. Often, transmission problems can be traced directly to poor maintenance.

Following is an inspection schedule that may be helpful in setting up a PM program. This schedule is not all inclusive as inspection intervals will vary depending upon operating conditions.

Daily

Air Tanks

Bleed air tanks to remove water or oil.

Oil Leaks

Check around bearing covers, PTO covers and other machined surfaces. Also check for oil leakage on the ground before starting truck in the morning.

Every 10,000 Miles

Check Oil Level

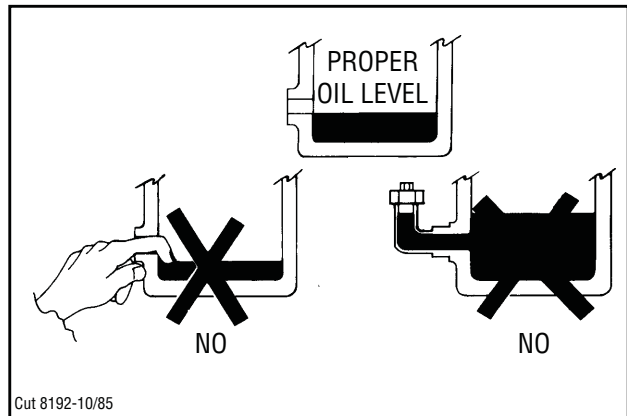

Every 20,000 Miles

Air System and Connections

Check for leaks, worn hoses and airlines, loose connections and loose capscrews.

Clutch Housing Mounting

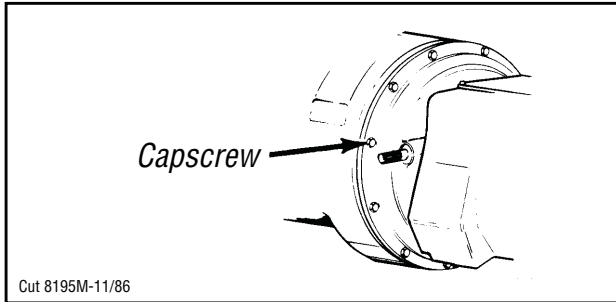

Check all capscrews in bolt circle of clutch housing for looseness.

Lubricated Pedal Shafts

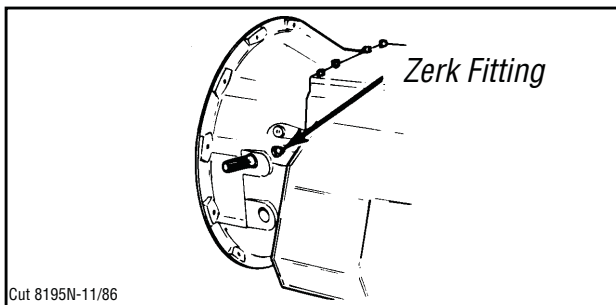

Check Remote Control Linkage

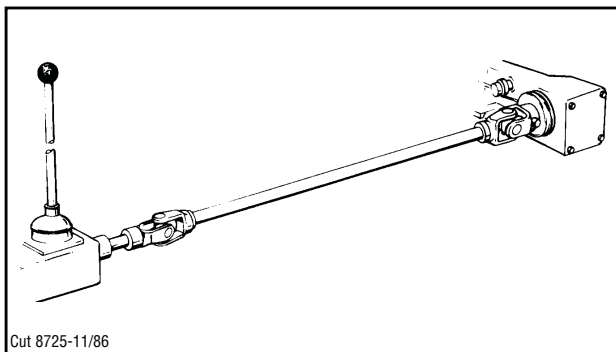

Check linkage U-joints for wear.

Check for binding.

Lubricate U-joints.

Check connections for tightness.

Check for bushing wear.

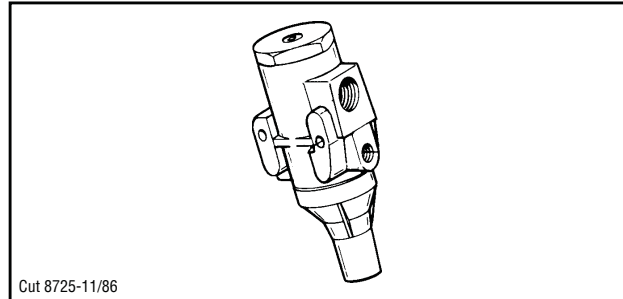

Check and clean or replace air filter element.

Universal Joint Companion Flange

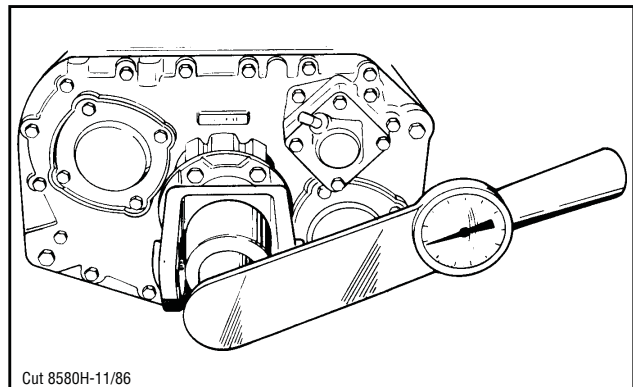

Check for proper torque, 450 to 500 lbs. ft. on twin countershaft models.

Output Shaft

Pry upward against output shaft to check radial clearance in mainshaft rear **bearing**.

Check splines for wear from movement and chucking action of the universal joint companion **flange**.

Every 40,000 Miles

Inspect Clutch

Note: Inspection should be made according to manufacturer's specifications.

Clutch

Check clutch disc faces for wear.

Check dampening action of clutch driven plate.

Release Bearing

Remove hand hole cover and check axial and radial clearance in release bearing.

Check relative position of thrust surface of release bearing with thrust sleeve on push type clutches.

Every *50,000 Miles

Change Transmission Lubricant

*Initial fill on new units should be changed at 5,000 miles (see LUBRICATION).

Fuller® Preventive Maintenance Recommendations

PM OPERATION	DAILY	5,000	10,000	20,000	30,000	40,000	50,000	60,000	70,000	80,000	90,000	100,000
Bleed Air Tanks and Listen for Leaks	X											
Inspect for Oil Leaks	X											
Check Oil Level			X	X	X	X	X	X	X	X	X	X
Inspect Air System Connections				X		X		X		X		X
Check Clutch Housing Capscrews for Looseness				X		X		X		X		X
Lube Clutch Pedal Shafts				X		X		X		X		X
Check Remote Control Linkage				X		X		X		X		X
Check and Clean or Replace Air Filter Element				X		X		X		X		X
Check Output Shaft for Looseness				X		X		X		X		X
Check Clutch Operation and Adjustment						X				X		
Change Transmission Oil		*X					X					X

*Initial fill on new units. See LUBRICATION section.

REPEAT SCHEDULE AFTER 100,000 MILES

LUBRICATION

Proper Lubrication. . . the key to long transmission life

Proper lubrication procedures are the key to a good all-around maintenance program. If the oil is not doing its job, or if the oil level is ignored, all the maintenance procedures in the world are not going to keep the transmission running or assure long transmission life.

Eaton® Fuller® Transmissions are designed so that the internal parts operate in a bath of oil circulated by the motion of gears and shafts.

Thus, all parts will be amply lubricated if these procedures are closely followed:

1. Maintain oil level. Inspect regularly.
2. Change oil regularly.
3. Use the correct grade and type of oil.
4. Buy from a reputable dealer.

Lubrication Change and Inspection

Eaton® Roadranger® CD50 Transmission Fluid	
HIGHWAY USE-Heavy Duty and Mid.Range	
First 3,000 to 5,000 miles (4827 to 8045 Km)	Factory fill initial drain.
Every 10,000 miles (16090 Km)	Check fluid level. Check for leaks.
Heavy Duty Highway Change Interval	
Every 250,000 miles (402336 km)	Change transmission fluid.
Mid.Range Highway Change Interval	
Every 100,000 miles (160,000 Km) or every 3 years whichever occurs first.	Change transmission fluid.
OFF-HIGHWAY USE	
First 30 hours	Factory fill initial drain.
Every 40 hours	Inspect fluid level. Check for leaks.
Every 500 hours	Change transmission fluid where severe dirt conditions exist.
Every 1,000 hours	Change transmission fluid (Normal off-highway use).
Heavy Duty Engine Lubricant or Mineral Gear Lubricant	
HIGHWAY USE	
First 3,000 to 5,000 miles (4827 to 8045 Km)	Factory fill initial drain.
Every 10,000 miles (16090 Km)	Inspect lubricant level. Check for teaks.
Every 50,000 miles (80450 Km)	Change transmission lubricant.
OFF-HIGHWAY USE	
First 30 hours	Change transmission lubricant on new units.
Every 40 hours	Inspect lubricant level. Check for leaks.
Every 500 hours	Change transmission lubricant where severe dirt conditions exist.
Every 1,000 hours	Change transmission lubricant (Normal off-highway use).

Change the oil filter when fluid or lubricant is changed.

Recommended Lubricants

Type	Grade (SAE)	Fahrenheit (Celsius) Ambient Temperature
Eaton® Roadranger® CD50 Transmission Fluid	50	All
Heavy Duty Engine Oil	50	Above 10°F(-12°C.)
MIL-L-2104B, C or D or API-SF or API-CD (Previous API designations acceptable)	40 30	Above 10°F(-12°C.) Below 10°F(-12°C.)
Mineral Gear Oil with rust and oxidation inhibitor API-GL-1	90 80W	Above 10°F(-12°C.) Below 10°F(-12°C.)

The use of mild EP gear oil or multipurpose gear oil is not recommended, but if these gear oils are used, be sure to adhere to the following limitations:

Do not use mild EP gear oil or multipurpose gear oil when operating temperatures are above 230°F (110°C). Many of these gear oils, particularly 85W140, break down above 230°F and coat seals, bearings and gears with deposits that may cause premature failures. If these deposits are observed (especially a coating on seal areas causing oil leakage), change to Eaton Roadranger CD50 transmission fluid, heavy duty engine oil or mineral gear oil to assure maximum component life and to maintain your warranty with Eaton. (Also see "Operating Temperatures".)

Additives and friction modifiers are not recommended for use in Eaton Fuller transmissions.

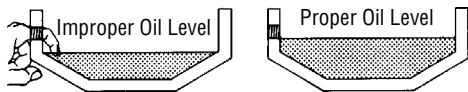

Proper Oil Level

Make sure oil is level with filler opening. Because you can reach oil with your finger does not mean oil is at proper level. **One inch of oil level is about one gallon of oil.**

Draining Oil

Drain transmission while oil is warm. To drain oil remove the drain plug at bottom of case. Clean the drain plug before reinstalling.

Refilling

Clean case around filler plug and remove plug from side of case. Fill transmission to the level of the filler opening. If transmission has two filler openings, fill to level of both openings.

The exact amount of oil will depend on the transmission inclination and model. Do not over fill; this will cause oil to be forced out of the transmission.

When adding oil, types and brands of oil should not be mixed because of possible incompatibility.

Operating Temperatures

– With Eaton® Roadranger® CD50 Transmission Fluid Heavy Duty Engine Oil and Mineral Oil

The transmission should not be operated consistently at temperatures above 250°F (120°C). However, intermittent operating temperatures to 300°F (149°C) will not harm the transmission. Operating temperatures above 250°F increase the lubricant's rate of oxidation and shorten its effective life. When the average operating temperature is above 250°F, the transmission may require more frequent oil changes or external cooling.

The following conditions in any combination can cause operating temperatures of over 250°F: (1) operating consistently at slow speeds, (2) high ambient temperatures, (3) restricted air flow around transmission, (4) exhaust system too close to transmission, (5) high horsepower, overdrive operation.

External oil coolers are available to reduce operating temperatures when the above conditions are encountered.

Transmission Oil Coolers are:

Recommended

- With engines of 350 H.P. and above with overdrive transmissions

Required

- With engines 399 H.P. and above with overdrive transmissions and GCWs over 90,000 lbs.
- With engines 399 H.P. and above and 1400 Lbs.-Ft. or greater torque
- With engines 450 H.P. and above

– With EP or Multipurpose Gear Oil

Mild EP gear oil and multipurpose gear oil are not recommended when lubricant operating temperatures are above 230°F (110°C). In addition, transmission oil coolers are not recommended with these gear oils since the oil cooler materials may be attacked by these gear oils. **The lower temperature limit and oil cooler restriction with these gear oils generally limit their success to milder applications.**

Proper Lubrication Levels as Related to Transmission Installation Angles

If the transmission operating angle is more than 12 degrees, improper lubrication can occur. The operating angle is the transmission mounting angle in the chassis plus the percent of upgrade (expressed in degrees).

The chart below illustrates the safe percent of upgrade on which the transmission can be used with various chassis mounting angles. For example: if you have a 4 degree transmission mounting angle, then 8 degrees (or 14 percent of grade) is equal to the limit of 12 degrees. If you have a 0 degree mounting angle, the transmission can be operated on a 12 degree (21 percent) grade.

Anytime the transmission operating angle of 12 degrees is exceeded for an extended period of time the transmission should be equipped with an oil pump or cooler kit to insure proper lubrication.

Note on the chart the effect low oil levels can have on safe operating angles. Allowing the oil level to fall 1/2" below the filler plug hole reduces the degree of grade by approximately 3 degrees (5.5 percent).

Proper Lubrication Levels are Essential!

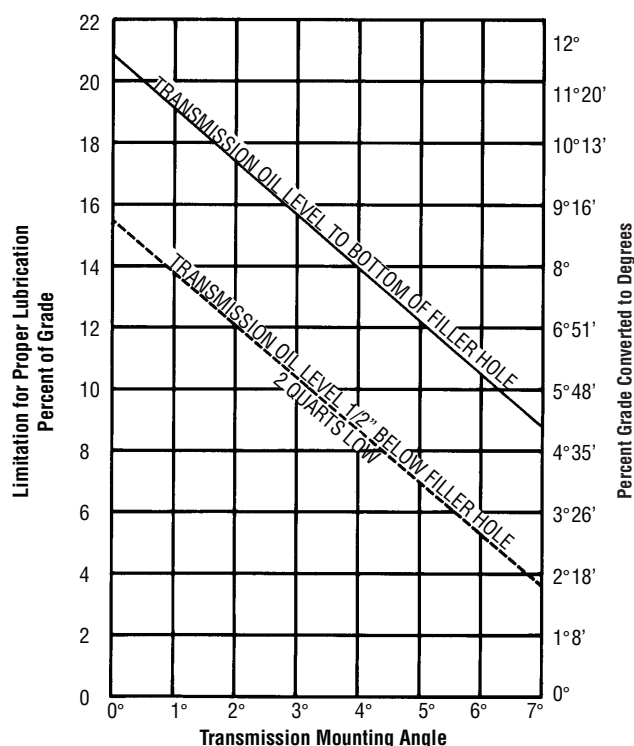

Dotted line showing "2 Quarts Low" is for reference only. Not recommended.

TORQUE RECOMMENDATIONS

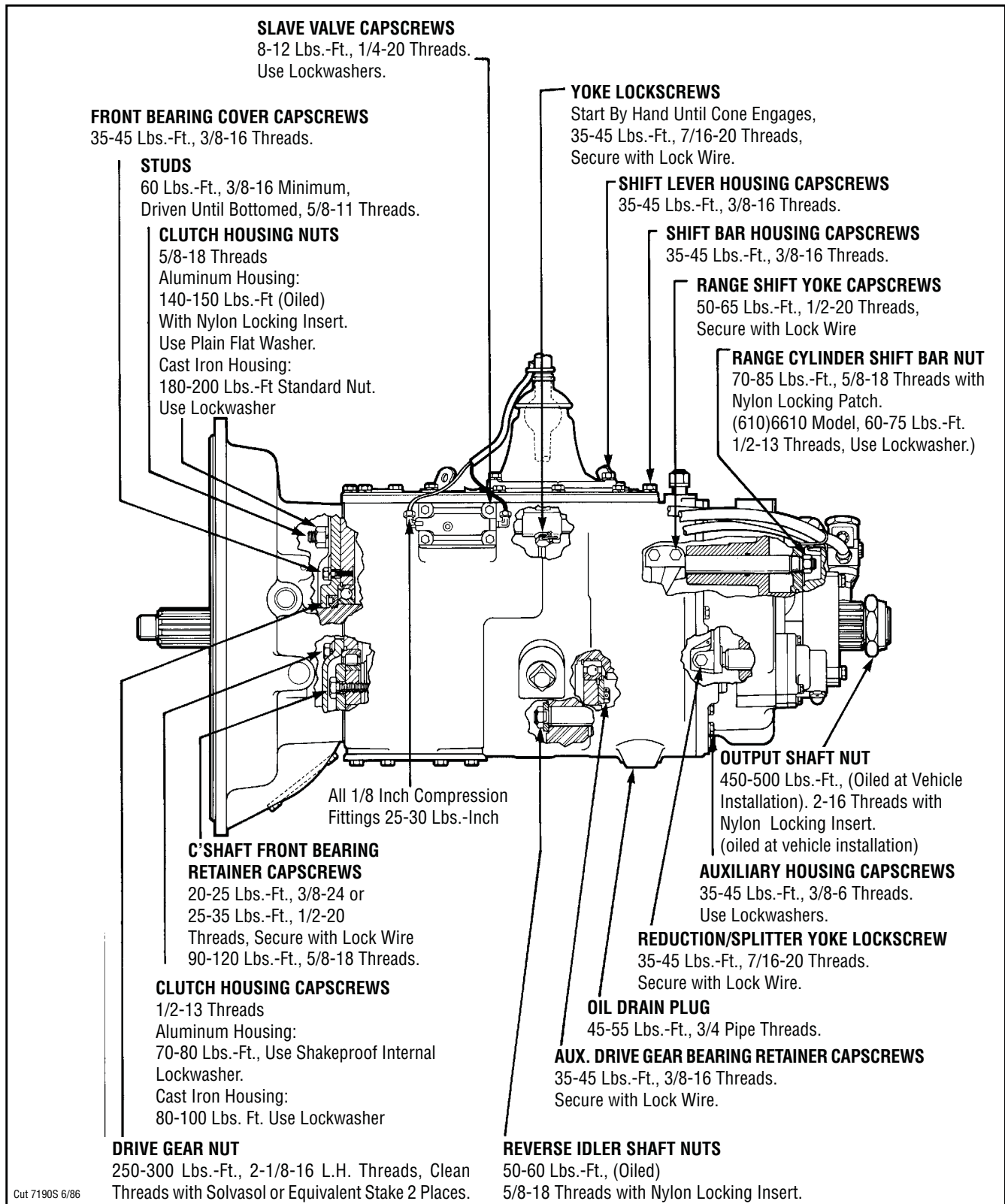

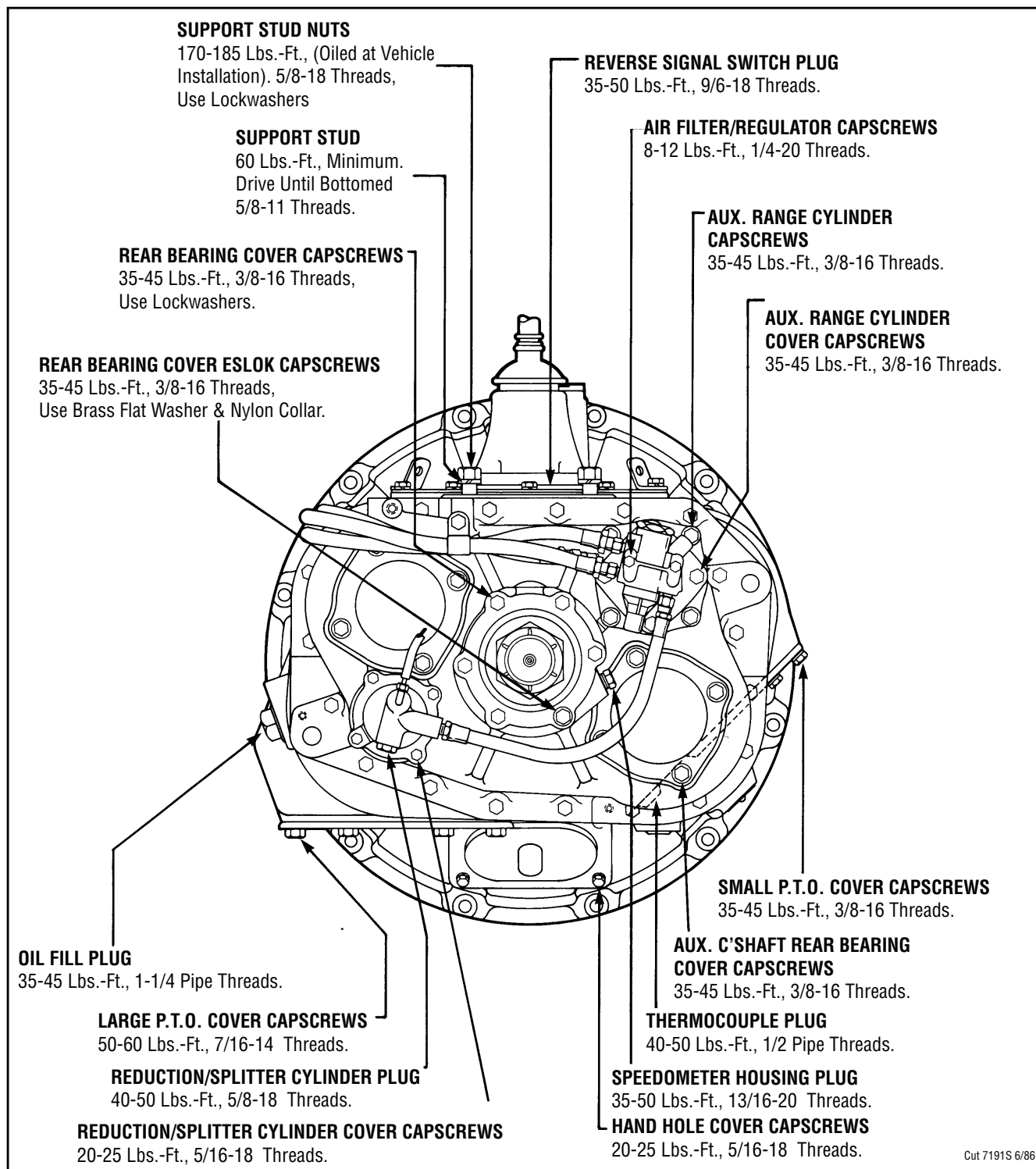

THREAD SEALING INSTRUCTIONS

- **Capscrews** – Apply Loctite 242
- **Drove Gear Nut, Clutch Housing Studs, and Support Studs** – Apply Thread Sealant (Fuller Part No. 71204)
- **Tapered Threads (Pipe Threads) and Airline Fittings** – Apply Hydraulic Sealant (Fuller Part No. 71205)

TROUBLESHOOTER'S GUIDELINE

Following is a basic procedure guideline for troubleshooting transmissions:

1. Preliminary Inspection.
 - a. Personal Observation – look for signs of misuse such as broken mounts, fittings or brackets; check airlines.
 - b. Question the Owner or Operator – gather information on operating conditions and vehicle use, on history of problem, and on shifting characteristics if affected.
 - c. Gather History of Unit – including maintenance and lubrication procedures, past failures, and mileage or hours of use.
2. Disassemble Transmission.
 - a. Keep oil sample for impurities, check if needed.
 - b. During disassembly, check for incorrectly installed parts, missing parts, and nongenuine parts.
 - c. Clean and inspect each piece closely.
3. Determine Type of Failure.
4. Determine and correct Cause of Failure.
8. Check airlines or hoses.
9. Tighten part.
10. Correct the restriction.
11. Recheck timing.
12. Clean part.
13. Apply thin film silicone.
14. Apply sealant.

To Use Guideline Chart

The Troubleshooter's Guideline Chart is used to locate and correct transmission problems.

To use the guideline, 1) Locate the transmission problem in the left hand column; 2) Trace line horizontally across the page until a rectangle with a number in it is reached; 3) Trace up vertical column to find a possible cause. The number in the intersection of the vertical and horizontal lines tell which corrections to use; 4) Possible corrections are listed below. There may be more than one possible cause and possible correction for each problem.

POSSIBLE CORRECTIONS

1. Instruct driver on proper driving techniques.
2. Replace parts (after trying other listed possible corrections).
3. Loosen lock-screw and retighten to proper torque.
4. Look for resultant damage.
5. Smooth with emery paper.
6. Reset to proper specifications.
7. Install missing parts.

PROBLEM	POSSIBLE CAUSE										
	1	2	3	4	5	6	7	8	9	10	
SLIP OUT (SPLITTER)	1 2								2	2	9
SLIP OUT (RANGE)									2	9	
SLIP OUT OR JUMP OUT (FRONT SECTION)	2		2 7								
SLOW SHIFT (SPLITTER)									2	2	9
SLOW SHIFT OR WON'T SHIFT (RANGE)									2	9	
HARD SHIFT OR WON'T SHIFT (FRONT SECTION)		2 3		5		2	2				
ABLE TO SHIFT FRONT SECTION INTO 2 GEARS AT ONCE					7						
GRINDING ON INITIAL LEVER ENGAGEMENT	2										
LEVER LOCKS UP OR STICKS IN GEAR											
NOISE											
GEAR RATTLE AT IDLE											
VIBRATION											
BURNED MAINSHAFT WASHER											
INPUT SHAFT SPLINES WORN OR INPUT SHAFT BROKEN											
CRACKED CLUTCH HOUSING											
BROKEN AUXILIARY HOUSING											
BURNED SYNCHRONIZER									2		
BROKEN SYNCHRONIZER											
HEAT											
TWISTED MAINSHAFT											
DRIVE SET DAMAGED											
BURNED BEARING											
OIL LEAKAGE									10		
OVERLAPPING GEAR RATIOS											

CONVERSION TABLE

Decimal Equivalents

1/64015625	17/64265625	33/64515625	49/64765625
1/3203125	9/3228125	17/3253125	25/3278125
3/64046875	19/64296875	35/64546875	51/64796875
1/160625	5/163125	9/165625	13/168125
5/64078125	21/64328125	37/64578125	53/64828125
3/3209375	11/3234375	19/3259375	27/3284375
7/64109375	23/64359375	39/64609375	55/64859375
1/8125	3/8375	5/8625	7/8875
9/64140625	25/64390625	41/64640675	57/64890625
5/3215625	13/3240625	21/3265625	29/3290625
11/64171875	27/64421875	43/64671875	59/64921875
3/161875	7/164375	11/166875	15/169375
13/64203125	29/64453125	45/64703125	61/64953125
7/3221875	15/3246875	23/3271875	31/3296875
15/64234375	31/64484375	47/64734375	63/64984375
1/425	1/25	3/475	1 1.0

Metric Conversions

1 mile = 1.609 kilometers (Km)
1 inch = 25.4 millimeters (mm)
1 pound = 0.453 kilograms (Kg)
1 pint = 0.473 liters (l)
1 pounds · feet = 1.356 Newton/Meters (N.m)

Metric Equivalents

MM	In.	MM	In.	MM	In.	MM	In.	MM	In.	MM	In.
1	.0394	21	.8268	41	1.6142	61	2.4016	81	3.1890	105	4.1339
2	.0787	22	.8661	42	1.6535	62	2.4409	82	3.2283	110	4.3307
3	.1181	23	.9055	43	1.6929	63	2.4803	83	3.2677	115	4.5276
4	.1575	24	.9449	44	1.7323	64	2.5197	84	3.3071	120	4.7244
5	.1969	25	.9843	45	1.7717	65	2.5591	85	3.3565	125	4.9213
6	.2362	26	1.0236	46	1.8110	66	2.5984	86	3.3858	130	5.1181
7	.2756	27	1.0630	47	1.8504	67	2.6378	87	3.4252	135	5.3150
8	.3150	28	1.1024	48	1.8898	68	2.6772	88	3.4646	140	5.5118
9	.3543	29	1.1417	49	1.9291	69	2.7165	89	3.5039	145	5.7087
10	.3937	30	1.1811	50	1.9685	70	2.7559	90	3.5433	150	5.9055
11	.4331	31	1.2205	51	2.0079	71	2.7953	91	3.5827	155	6.1024
12	.4724	32	1.2598	52	2.0472	72	2.8346	92	3.6220	160	6.2992
13	.5118	33	1.2992	53	2.0866	73	2.8740	93	3.6614	165	6.4961
14	.5512	34	1.3386	54	2.1260	74	2.9134	94	3.7008	170	6.6929
15	.5906	35	1.3780	55	2.1654	75	2.9528	95	3.7402	175	6.8898
16	.6299	36	1.4173	56	2.2047	76	2.9921	96	3.7795	180	7.0866
17	.6693	37	1.4567	57	2.2441	77	3.0315	97	3.8189	185	7.2835
18	.7087	38	1.4961	58	2.2835	78	3.0709	98	3.8583	190	7.4803
19	.7480	39	1.5354	59	2.3228	79	3.1102	99	3.8976	195	7.6772
20	.7874	40	1.5748	60	2.3622	80	3.1496	100	3.9370	200	7.8740
										300	11.8110

Conversion Table

Metric Conversion Factors

Approximate Conversions to Metric Measures				
Symbol	When You Know	Multiply by	To Find	Symbol
LENGTH				
in	inches	*2.5	centimeters	cm
ft	feet	30	centimeters	cm
yd	yards	0.9	meters	m
mi	miles	1.6	kilometers	km
AREA				
in ²	square inches	6.5	square centimeters	cm ²
ft ²	square feet	0.09	square meters	m ²
yd ²	square yards	0.8	square meters	m ²
m ²	square miles	2.6	square kilometers	km ²
	acres	0.4	hectares	ha
MASS (weight)				
oz	ounces	28	grams	g
lb	pounds	0.45	kilograms	kg
	short tons (2000 lb)	0.9	tonnes	t
VOLUME				
tsp	teaspoons	5	milliliters	ml
Tbsp	tablespoons	15	milliliters	ml
fl oz	fluid ounces	30	milliliters	ml
c	cups	0.24	liters	l
pt	pints	0.47	liters	l
qt	quarts	0.95	liters	l
gal	gallons	3.8	liters	l
ft ³	cubic feet	0.03	cubic feet	m ³
yd ³	cubic yards	0.76	cubic meters	m ³
TEMPERATURE (exact)				
°F	Fahrenheit temperature	5/9 (after subtracting 32)	Celsius temperature	°C

Approximate Conversions to Metric Measures				
Symbol	When You Know	Multiply by	To Find	Symbol
LENGTH				
mm	millimeters	0.04	inches	in
cm	centimeters	0.4	inches	in
m	meters	3.3	feet	ft
m	meters	1.1	yards	yd
km	kilometers	0.6	miles	mi
AREA				
cm ²	square centimeters	0.16	square inches	in ²
m ²	square meters	1.2	square yards	yd ²
km ²	square kilometers	0.4	square miles	m ²
ha	hectares (10,000 m ²)	2.5	acres	
MASS (weight)				
g	gram	0.035	ounces	oz
kg	kilograms	2.2	pounds	lb
t	tonnes (1000 kg)	1.1	short tons	
VOLUME				
ml	milliliters	0.03	fluid ounces	fl oz
l	liters	2.1	pints	pt
l	liters	1.06	quarts	qt
l	liters	0.46	gallons	gal
m ³	cubic meters	35	cubic feet	ft ³
m ³	cubic meters	1.3	cubic yards	yd ³
TEMPERATURE (exact)				
°C	Celsius temperature	9/5 (then add 32)	Fahrenheit temperature	°F

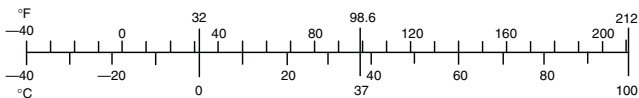

TOWING OR COASTING

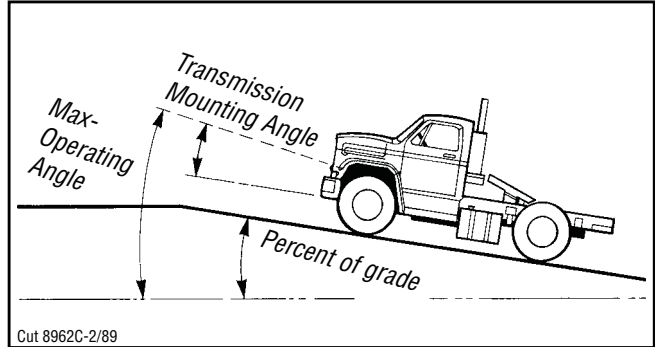
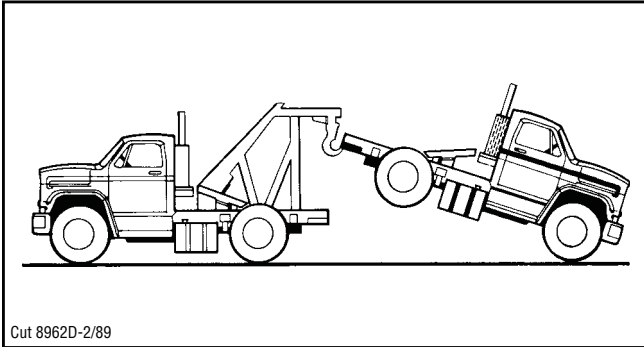

Fuller transmissions require rotation of the front section countershaft and mainshaft gears to provide adequate lubrication. These gears do not rotate when the vehicle is towed with the rear wheels on the ground and the drive train connected. The mainshaft, however, is driven at a high rate of speed by the rear wheels. The friction between the mainshaft splined washers, due to the lack of lubrication and the extreme difference in rotational speeds, will severely damage the transmission. Coasting with the transmission in neutral will produce the same damage.

To prevent this kind of damage:
Never coast with the transmission in neutral.

Never coast with the clutch depressed.

When towing, pull the axle shafts, or disconnect the drive-line, or tow with the drive wheels off the ground.

Copyright Eaton, 2013

Eaton hereby grant their customers, vendors, or distributors permission to freely copy, reproduce and/or distribute this document in printed format. It may be copied only in its entirety without any changes or modifications. THIS INFORMATION IS NOT INTENDED FOR SALE OR RESALE, AND THIS NOTICE MUST REMAIN ON ALL COPIES.

Note: Features and specifications listed in this document are subject to change without notice and represent the maximum capabilities of the software and products with all options installed. Although every attempt has been made to ensure the accuracy of information contained within, Eaton makes no representation about the completeness, correctness or accuracy and assumes no responsibility for any errors or omissions. Features and functionality may vary depending on selected options.

For spec'ing or service assistance, call 1-800-826-HELP (4357) or visit www.eaton.com/roadranger. In Mexico, call 001-800-826-4357.

Roadranger: Eaton and trusted partners providing the best products and services in the industry, ensuring more time on the road.

Eaton

Vehicle Group
P.O. Box 4013
Kalamazoo, MI 49003 USA
800-826-HELP (4357)
www.eaton.com/roadranger

Printed in USA