

Model 410 & 410C Flame Photometer

Operator Manual

Copyright 2004 Sherwood Scientific Ltd.
All rights reserved.

Intended Use

The Model 410 is a single channel, low temperature flame photometers for the determination of Na, K and Ca. All references to M410 also apply to the M410C, which is also described in the Appendix B. This operator's manual contains complete instructions for setting up and using the Model 410. Service information for use by appropriately qualified personnel is also available.

The Model 410 is intended for use by persons knowledgeable in safe laboratory practices. If the instrument is not used in accordance with these instructions for use, the protection provided by the equipment may be impaired.

WARNING *The Model 410 is designed to be grounded through the power supply lead (line cord) for safe operation. For the safety of operating personnel and optimum performance make sure that the instrument is only connected to a 3-prong socket (outlet) that has an effective earth connection. If you are in any doubt about the safety of your electrical supply system consult a competent, qualified electrician.*

There are no user replaceable parts within the instrument. Do not remove the rear cover from the instrument.

Sherwood Scientific Limited and its authorized Distributors and Agents consider themselves responsible for the effects of safety, reliability and performance of the Model 410 only if:

- Assembly operations, extensions, re-adjustments, modifications or repairs are only carried out by persons authorized by them.
- The electrical installation of the relevant room complies with IEC requirements or the local regulatory code.
- The equipment is used in accordance with the instructions for use.

The information contained in this manual was correct at the time of going to print. However, Sherwood Scientific's policy is one of continuous product improvement and the right to change specifications, equipment and maintenance procedures at any time, without notice, are reserved.

This manual is copyrighted, and all rights are reserved. No part of this manual may be reproduced by any means or in any form without prior consent in writing.

Sherwood Scientific Ltd,
1 The Paddocks,
Cherry Hinton Road,
Cambridge,
CB1 8DH,
United Kingdom

Tel : +44 1223 243444

Fax : +44 1223 243300

Email info@sherwood-scientific.com

www.sherwood-scientific.com

Contents

	Page
Intended Use	2
1 Introduction	5
1.1 Introduction	5
1.2 Summary of the Test	5
1.3 Reagents	6
Purification	6
2 Installation	7
2.1 Services Required	7
Electrical Supply	7
Fuel	7
Air	7
Waste Container	7
2.2 Site Conditions	8
2.3 Unpacking	9
Accessory List	9
2.4 Assembly	9
2.5 Connecting a Chart Recorder	15
3 Principles of Operation	16
3.1 Flame Photometry	16
4 Performance Characteristics and Specification	17
4.1 Readout	17
4.2 Measurement Ranges	17
4.3 Specificity	17
4.4 Accuracy	17
Linearity	17
Drift	17
Reproducibility	18
4.5 Warm Up	18
4.6 Sample Requirement	18
Type	18
Method of presentation	18
Volume	18
4.7 Chart Recorder Output	18
4.8 Environmental Conditions	19
Temperature	19
Humidity	19
Installation Category	19
4.9 Power Requirements	19
Voltage	19
Fuses	19
Power	19
4.10 Fuel	19
4.11 Air	19
4.12 Size	19
4.13 Weight	19

Contents

	Page
5 Operating Instructions	20
5.1 Front Panel Controls and Indicators (See Fig 5.1)	20
Power on	20
Flame on	20
Blank	20
Sensitivity Fine and Coarse	20
Fuel	20
Na, K, Li	20
Decimal	20
Power 0/1	20
Power	23
Data output	23
Gas	23
Air	23
Air regulator	23
5.3 Initial Adjustment	24
5.4 Operating Instructions	25
5.5 Shutdown Procedure	27
5.6 Operating Hints	27
6 Operational Precautions and Limitations	28
6.1 General	28
6.2 Hazards	28
7 Maintenance	29
7.1 General	29
7.2 Daily Maintenance	29
7.3 Weekly Maintenance	29
7.4 Monthly Maintenance	29
7.5 Six-Monthly Maintenance	30
7.6 Nebuliser	30
Operational Check	30
Cleaning the Nebuliser	30
7.7 Cleaning the Mixing Chamber, Burner and Drain	32
7.8 Cleaning the Optical Filters and Glass Chimney	33
7.9 Voltage Selection and Fuse Replacement	35
7.10 Deproteinising or Disinfecting Procedure	36
8 Troubleshooting	37
8.1 Power on LED not illuminated	37
8.2 Flame on LED not illuminated	37
General	37
Air Supply	37
Fuel Supply	37
8.3 Unable to set display to zero	38
8.4 Unable to set display to standard reading	38
8.5 Unstable results	38
8.6 Non-linear results	39
9 Spares and Accessories	40
9.1 Ordering Information	40
9.2 Spares and Accessories	40
9.3 Standard Solutions	41
Appendix A	42
Bibliography	42
Appendix B	43
M410c	43
Product Warranty	48

1

Introduction

1.1 Introduction

The Sherwood Scientific Model 410 is a single channel, low temperature flame photometer for the determination of Na, K and Li in clinical samples. Information on Ca and Ba determinations is also available from your Sherwood Scientific distributor. The Model 410 utilises a digital display and is designed for reliable, trouble-free operation and ease of maintenance.

An automatic sample dilutor, Model 805 is available.

The Model 410 has a fail-safe device, which automatically stops the gas flow if the flame does not ignite, or if during operation, the flame is extinguished. Plus an air pressure switch so that if the air pressure falls below a specified value the flame will not ignite or will be extinguished.

1.2 Summary of the Test

NOTE References are listed in Appendix A.

Prior to the advent of flame photometry, Sodium and Potassium were typically determined gravimetrically after the precipitation of relatively insoluble salts such as Sodium Uranyl Zinc Acetate (Ref. 1) and Potassium Chloroplatinate (Ref. 2). As with all chemical methods for these two elements there were cross interferences and also interference from other ions such as NH_4^+ . Many analytical steps such as protein precipitation or ashing of the sample were involved with all the attendant losses and inaccuracies and the complete procedures required many hours.

In many applications, rapid availability of results is of prime importance. By flame photometry both Sodium and Potassium results on a single sample can be available in less than 5 minutes of the sample reaching the laboratory. (The same is true of Lithium results, a determination that was never carried out before the advent of flame photometry). A simple dilution step is all that is required; therefore sample handling, losses and inaccuracies are at a minimum (Ref. 3-10)

Introduction continued**1.3 Reagents**

Sherwood Scientific supplies a wide range of reagents, including standards, diluent and maintenance solutions, for use with the Model 410 Flame Photometer.

Please refer to Section 9.3 and Appendix B for a complete list of the reagents.

Dilutions

Samples and standards must be diluted with the same batch of diluent, made up of 1 part Diluent Concentrate to 999 parts deionised or good quality distilled water.

The same batch of diluent should be used to zero the instrument and to prepare dilutions of standards and samples. This will prevent variations in water purity affecting the measurements.

Great care should be taken so that contamination does not occur when preparing the samples and standards. Remember that the accuracy of the instrument is dependent on the accuracy and purity of the standards used for calibration.

Storage

All solutions should be stored away from direct sunlight, in a cool place (below +25°C/+77°F), in an airtight container to prevent evaporation and discolouration. Glass containers should not be used, as they can affect Na concentration levels. Prolonged exposure to the atmosphere must be avoided to prevent evaporation of standard solutions, which could affect concentration.

Purification

No purification is required for Sherwood Scientific standard solutions.

2

Installation

2.1 Services Required

Electrical Supply

An a.c. supply at 100V, 120V, 220V or 240V $\pm 10\%$, at 50 or 60Hz, is required for the Model 410. The instrument operating voltage is shown on the voltage selector on the rear panel.

CAUTION *If the voltage setting is not correct for the local supply, do not attempt to use the instrument until it is correctly adjusted as detailed in Section 2.4, paragraph 23.*

Fuel

A supply of Propane, Butane or Propane/Butane mixture regulated at the cylinder to 2.1kg/cm² (30psig), flow rate at least 0.4 litres per minute. The use of industrial quality gas is not recommended as impurities can enter the delicate gas regulators and can leave deposits of oil and dirt, which will render the instrument inoperable.

Natural gas at 3 to 10 inches water gauge, regulated to 2 inches water gauge, can also be used. Natural gas and camping gas regulators are available as optional accessories, refer to Section 9.2.

NB The positioning of Gas cylinders should conform to National and local regulations.

Air

A supply of clean, dry, oil-free air at 1kg/cm² (14psig), flow rate 6 litres per minute. A suitable Sherwood Scientific air compressor is listed in Section 9.2.

Waste Container

A sink or waste container sited to the right of the instrument will ensure the minimum length of waste tubing. Do not use a waste container with high sides, as this will cause the drain tube to be lifted above the level of the constant head drain.

Installation continued**2.2 Site Conditions**

WARNING *Under no circumstances install the instrument beneath overhanging cupboards. There must be at least 1 metre of clear space above the chimney.*

For optimum performance, this instrument should be installed in accordance with the following conditions: -

1. The environment must be clean and free from dust.
2. The instrument must be placed on a strong, level worktop, free from vibration. The Model 410 requires approximately 500mm x 500mm of bench space, which includes an area in front for solutions and clearance at the rear for fuel and air tubing, with clear access to the mains supply switch.
3. Avoid sites that expose the instrument to direct sunlight or draughts.
4. To meet the specification the ambient temperature must be within the range 10°C to 35°C and the maximum relative humidity must not be more than 85%, non-condensing.
5. Make sure that the correct voltage is selected for the local a.c. supply, as shown in the following table. *Do not* attempt to connect the power supply lead until the voltage is correctly set.

VOLTAGE SELECTED	VOLTAGE RANGE
100V	90V to 110V
120V	100V to 132V
220V	198V to 229V
240V	230V to 264V

Installation continued**2.3 Unpacking**

1. Unpack the instrument and accessories.
NOTE The Model 410 weighs 9.5kg, follow safe lifting techniques.
2. Check all items for damage.
3. Check that all the items on the Accessory List have been delivered. Contact your Sherwood Scientific distributor if you have any problems.
4. The Model 410 is shipped with the following items:

Accessory List

CAT. NO.	ITEM	QUANTITY
001 72 043	Air tubing, nylon reinforced	2 metres
001 72 114	Fuel tubing	2 metres
001 72 080	Drain tube, 200 mm, and spare tube 200mm	1 pack
001 48 105	Fuse, 200 mA slo-blo, spares	2
471 71 900	Supply lead, a.c.	1
100 99 010	Nebuliser cleaning wire, pack of 3	1 pack
001 31 076	'O' ring, spare for mixing chamber	1
420 08 102	Nebuliser	1
400 22 003	Nebuliser inlet tube, polythene, 150mm	1
410 91 002	Operators Manual, English	1
001 08 718	'Unex' tubing clamp	4

supplied with the M410 only (see addendum 9.4 for 410C Standards)

001 56 620	Flame Photometer Standard, 1000ppm Na, 100ml	1 pack of 6
001 56 621	Flame Photometer Standard, 1000ppm K, 100ml	1 pack of 6
001 56 623	Flame Photometer Standard, 1000ppm Ca, 100ml	1 pack of 6

2.4 Assembly

EQUIPMENT REQUIRED: -

'Poqidriv' (cross head) screwdriver IPT;

Flat blade screwdriver.

To assemble the Model 410, proceed as follows:

1. Lift off the chimney cap from the chimney assembly and lift out the glass chimney. Remove any packing material from inside, making sure that there are no small pieces left within the chimney.
2. Replace the glass chimney with the clear strip at the bottom and refit the chimney cap on top of the chimney.
3. Remove the nebuliser from its box and screw it to the connector on the end of the air tubing (item 3, Figure 2.1). Fit the nebuliser to the mixing chamber and position the retainer to lock it into position (item 2, Figure 2.1). Fit the nebuliser inlet tube, making sure that it is pointing downwards.

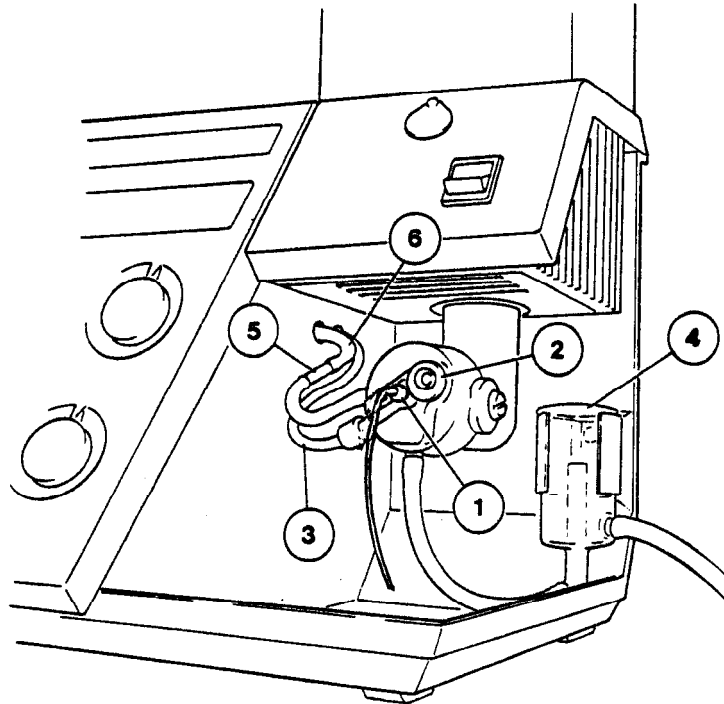
Installation continued**2.4 Assembly** continued**Figure 2.1** **Mixing Chamber**

1. Nebuliser. 2. Nebuliser retainer. 3. Air tubing. 4. Constant head drain.
5. Fuel restrictor. 6. Fuel tubing.

4. If the instrument is to be used on Natural gas, proceed with paragraph 6. If Propane or Butane is to be used continue with paragraph 5.
5. Connect the length of rubberised fuel tubing, (001 72 114) supplied, between the inlet connector on the Propane regulator, (item 5, Figure 2.2) and the cylinder regulator outlet connector. Secure with 'Unex' tubing clamps, supplied. Ensure that the connector at the regulator inlet is tightened to 12nm torque. Continue with paragraph 15.

NB The connection at the cylinder end of the tube must comply with National regulations.
6. Remove the fuel restrictor (item 5, Figure 2.1) and connect the fuel tubing (item 6, Figure 2.1) directly to the mixing chamber connection.
7. Unscrew and remove the gas inlet, regulator inlet and regulator outlet connectors (items 4, 5 and 6, Figure 2.2) and remove the copper tubing (item 2, Figure 2.2).
8. Connect the regulator inlet, with connector, (item 5, Figure 2.2) to the gas inlet (item 4, Figure 2.2).

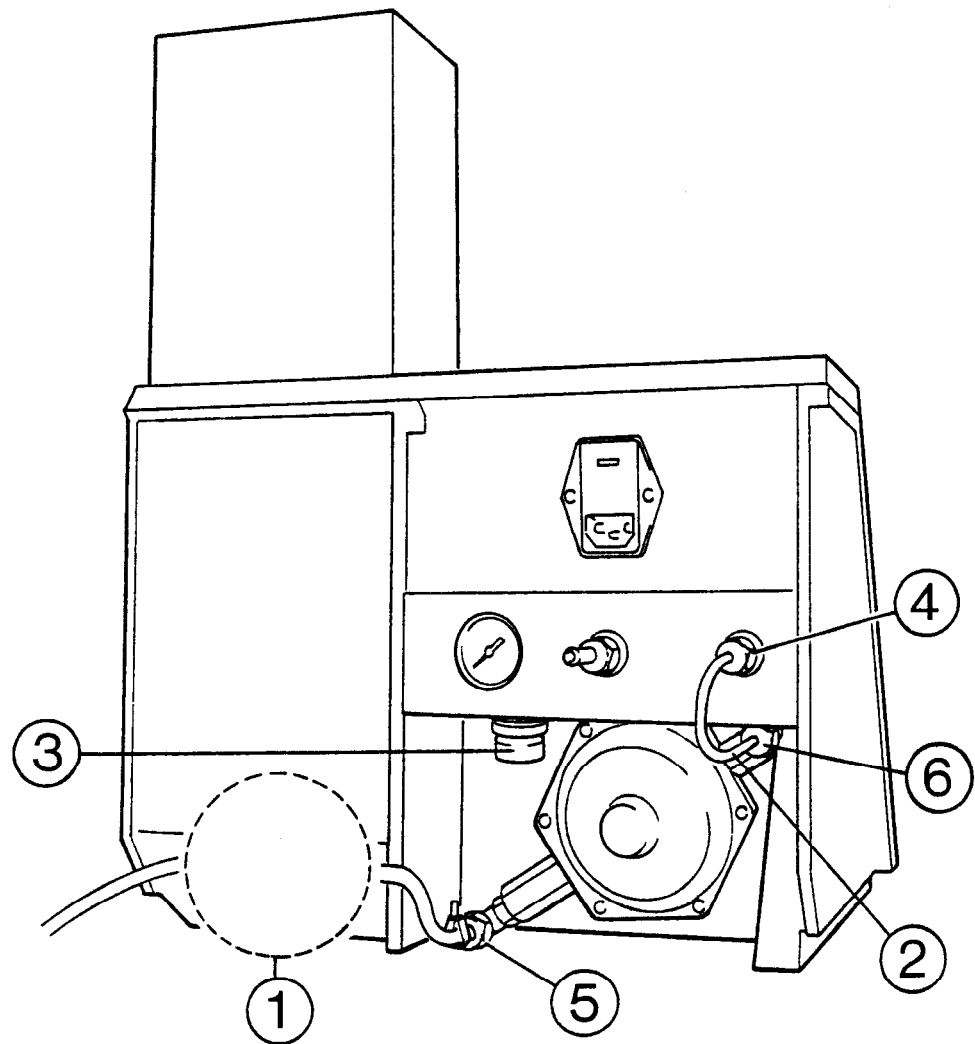
Installation continued**2.4 Assembly** continued**Figure 2.2 Rear Panel**

1. Natural gas regulator assembly (see Figure 2.3). 2. Copper tubing.
 3. Air regulator adjuster. 4. Gas inlet connector. 5. Regulator inlet connector.
 6. Regulator outlet connector.

9. Locate the Natural gas regulator and mounting bracket ordered as optional accessories and packed separately from the instrument. Fit the mounting bracket to the rear panel with the two screws supplied and slot in the Natural gas regulator, Figure 2.3. Make sure that the gas flow arrow on the regulator points to the right.
10. Connect the Natural gas supply to the Natural gas regulator inlet with the fuel tubing and 'Unex' clamp supplied with the instrument.

Installation continued**2.4 Assembly** continued

11. If it is necessary to fit the filter because of suspected dirty gas then this should be fitted before the Natural Gas regulator by cutting the rubber hose and fitting the filter in the tubing with the arrow pointing towards the regulator. Secure the tubing to the filter and regulator with the extra Unex clips supplied with the Natural Gas regulator kit.
12. Connect the Natural gas outlet tubing (supplied with the regulator) to the gas inlet connector (item 4, Figure 2.2), using the connector and nipple removed as described in paragraph 7 above bypassing the Propane/Butane regulator. Secure with 'Unex' clamp supplied.

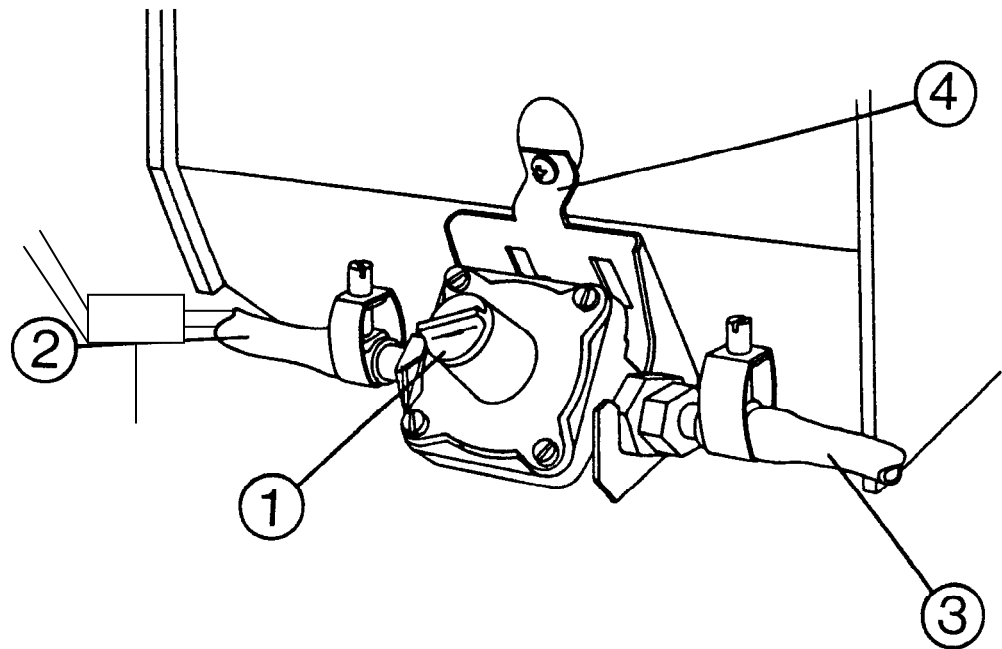
**Figure 2.3 Natural Gas Regulator**

1. Regulator screw cap.
2. Filter in line with Rubber hose supplied with instrument.
3. Natural gas outlet tubing. 4. Mounting bracket.

13. Remove the screw cap (item 1, Figure.2.3). Rotate the screw head fully clockwise, and then counterclockwise exactly one turn.
14. Refit screw cap.
15. Turn on the fuel supply and check all connectors for leaks, using soap solution. Do not use the instrument until you are satisfied that the installation is leakproof.
16. Connect the length of reinforced Nylon hose, supplied, between the air compressor outlet and the air inlet connector on the rear panel. Secure both ends with 'Unex' tubing clamps, supplied.

Installation continued**2.4 Assembly** continued

17. Fit one of the 200mm lengths of drain tubing (item 4, Figure 2.4) to the outlet on the constant head drain (or Gas Trap). If necessary connect a suitable length of tubing (not supplied), to extend the drain tubing to carry waste to a sink or other drain receptacle. The downward flow of waste must not be restricted. The second length of tubing supplied is a spare for either the 'U' tube or drain tube.

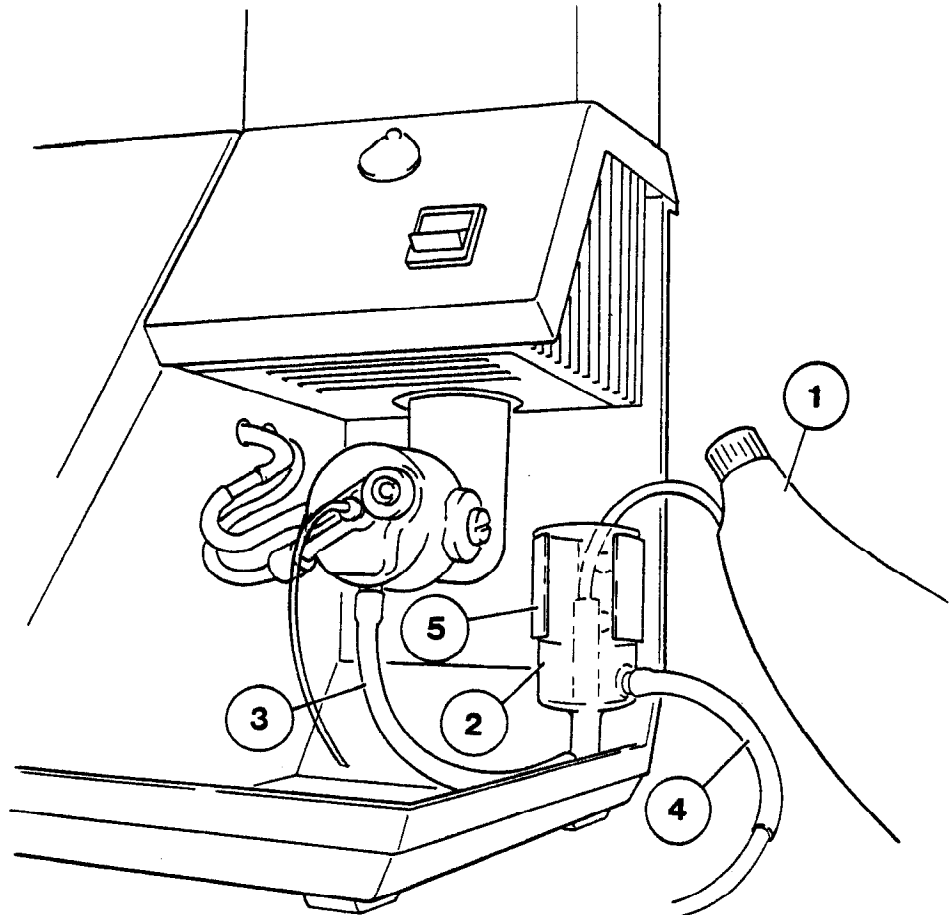

Figure 2.4 Filling the 'U' Tube

1. Wash bottle. 2. Constant head drain (Gas Trap). 3. 'U' tube. 4. Drain tube.
5. Spring clip.

18. *Make sure* that the constant head drain (Gas Trap) is positioned so that the lip at the top is resting on the spring clip. Use a wash bottle (item 1, Figure 2.4) to fill the 'U' tube with deionised water. Sufficient water should be used to purge the tube of air. Allow excess water to flow back into the drain.

IMPORTANT Do not continue until you are satisfied that the 'U' tube has been completely filled with water, and is purged of air.

Installation continued**2.4 Assembly** continued

19. The instrument is supplied with Na, K and Ca filters fitted. To replace any of these filters, refer to Section 7.8.

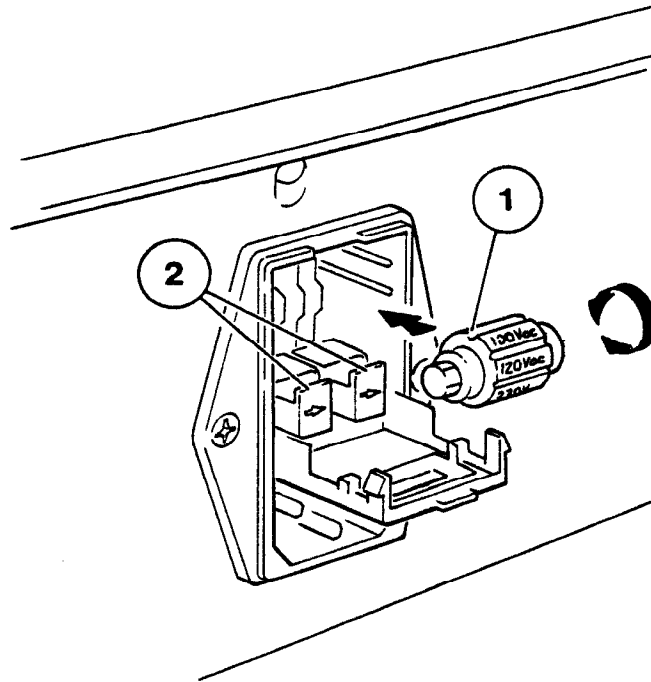

Figure 2.5 Voltage Selector

1. Voltage selector. 2. Fuse holders.

20. Check that the voltage shown on the voltage selector is correct for the local supply. If it is not, open the voltage selector compartment. Slide the voltage selector bobbin, item 1, Figure 2.5 out of the instrument and replace it so that the required voltage setting will be visible through the window of the compartment cover. Close the compartment cover.

CAUTION Do not attempt to rotate the voltage selector bobbin when it is fitted in the voltage selector, as this will damage the contacts.

21. Fit a suitable 3-pin plug to the a.c. supply lead. Check that the correct colour coded leads are connected to the plug terminals. Follow the plug manufacturer's fitting instructions.

CAUTION Ensure that the green/yellow earth connector in the a.c. supply lead is connected to a properly grounded earth point, the brown lead is connected to the Line terminal (L) and blue lead is connected to the Neutral terminal (N).

22. If necessary, set the *power switch* (below the chimney) to the 0 position. Connect the a.c. supply lead to the *power* receptacle on the rear panel and connect the plug to a convenient supply socket.
23. If a chart recorder is to be used with the instrument continue with Section 2.5. If not, continue with Section 5, Operating Instructions.

Installation continued**2.5 Connecting a Chart Recorder**

1. Connect a black plug (Cat. No. 001 42 017) to the black (-ve) recorder input lead and a red plug (Cat. No. 001 42 254) to the red (+ve) input lead.
2. Fit the plugs into the appropriate *data output* sockets on the rear panel of the instrument.
3. If the chart recorder has an input-shortening link fitted, connect it between the black (negative) input and the earth input. This may reduce interference and produce a better trace.
4. Continue with Section 5, Operating Instructions.

3

Principles of Operation

3.1 Flame Photometry

When metal ions in solution are aspirated into a low temperature flame (in an aerosol form) the electrons of the ion are excited to higher energy states.

When these electrons return to the ground state, they lose the excitation energy and a discrete wavelength of visible light is emitted. This light wavelength can be isolated from other light wavelengths by an optical filter and the amount of light emitted can be detected with a suitable photodetector. The amount of light emitted is proportional (for low concentrations of metal ion only) to the number of ions in the flame and hence the number of ions in solution.

The electrical signal from the photodetector is amplified and displayed on a digital readout.

4

Performance Characteristics and Specification

4.1 Readout

3½-digit light emitting diode (LED) display, 12.5mm high.
Display range 0 to 1999 (199.9 with decimal point on).

NOTE If negative values are displayed the instrument is operating outside of the recommended measurement range.

4.2 Measurement Ranges

Na 0-10ppm linear;
Above this range Na is non-linear due to self-absorption. A lineariser can be fitted, which will linearise concentrations up to 60ppm Na. (Part number 47829800).

K, Li & Ca 0 to 100ppm.

Ba 0-3000ppm

These are sample concentrations directly entering the flame photometer after dilution.

4.3 Specificity

For Na, K and Li measurements, interference will be less than 0.5% from other elements at the same concentration equal to the concentration of the element under test. Ca and Ba will normally be less than 5 % interference from other elements at the same concentration.

4.4 Accuracy

Linearity

Better than 2% measured at mid-range, when standardized at the following concentrations 3ppm Na, 3ppm K & 5ppm Li.

Drift

At zero: Better than 2% per hour when calibrated at 10ppm for Na, K and Li and at 50 ppm for Ca and Ba.

At 10ppm: Better than 2% per 5 minutes, for Na, K, Li, Ca and Ba based on 10 consecutive samples, aspirating sample for 20 seconds, then 10 seconds of air.

NOTE A minimum 30 minutes warm up must be allowed to meet the drift specification, refer to Section 4.5.

Performance Characteristics and Specification continued

4.4 Accuracy continued

Reproducibility

NOTE The following specification is correct for use on Propane or Butane. If Natural Gas is used the reproducibility may be slightly worse.

Less than 2% CV for 20 consecutive readings of the same bulk sample, aspirating sample for 20 seconds then 10 seconds of air. The concentration of the bulk sample to be 10ppm for Na, K and Li which will give a standardized reading of 100 on the display, i.e. 10.0 with decimal point on.

4.5 Warm Up

To achieve the stated specification the flame must be alight for a minimum of 30 minutes, with diluent being aspirated.

4.6 Sample Requirement

Type

Dependent on application. However, samples should be water-based and not highly viscous nor non-homogeneous.

Organic solvents affect the air/fuel ratio, could attack the mixing chamber materials and can affect the safety operation of the Gas Trap (constant head drain) and should be used with great caution.

Method of presentation

The sample is presented to the nebuliser from a sample cup, test-tube, or other suitable container.

Volume

The maximum diluted sample volume required for 20 seconds aspiration is 2ml.

4.7 Chart Recorder Output

Nominal 100mV signal output per 1000 display units.

Performance Characteristics and Specification continued

4.8 Environmental Conditions

Temperature

Operating +10°C to +35°C; Transportation -40°C to +45°C.

Humidity

Operating 85% maximum at +35°C.

Transportation 95% maximum at +45°C (non condensing).

The instrument specification will be unaffected by an ambient temperature change of 4°C (or less) per hour, within the range +10°C to +35°C, with a maximum of 7°C shift during 8 hours.

Installation Category

Installation Category 1.

4.9 Power Requirements

Voltage

90V to 132V or 198V to 264V, 50/60Hz.

Fuses

Two 200mA slo-blo fuses are fitted for all voltage ranges.

Power

20VA.

4.10 Fuel

High-grade Propane, Butane or Propane/Butane mixture. All fuels to be free of heavy hydrocarbon deposits and regulated at the cylinder to approximately 2.1kg/cm² (30psig). Natural Gas at 3 to 10 inches water gauge, regulated to 2 inches water gauge, using optional natural gas regulator.

NOTE Natural Gas may give reproducibility results outside specification.

4.11 Air

A supply of clean air at a minimum pressure of 1kg/cm² (14psig) at 6 litres/minute, as supplied by a Model 851 Air Compressor. Maximum inlet pressure 2.1kg/cm² (30psig). If condensation problems arise a Model 856 Air Compressor should be used, which has a water separator fitted.

4.12 Size

Overall, including chimney and rear panel connectors, 510mm high x 390mm wide x 345mm deep.

4.13 Weight

9.5 kg, 410 only.

5

Operating Instructions

5.1 Front Panel Controls and Indicators (See Fig 5.1).

Power on

LED which illuminates when the instrument is switched on.

Flame on

LED which illuminates when the flame is alight.

Blank

This control is used to set the display to zero while aspirating a blank solution.

Sensitivity Fine and Coarse

These two controls are used to set the display to an appropriate concentration reading, while aspirating a standard solution. The *coarse* control is a four position rotary switch and the *fine* control is a 10-turn potentiometer.

Fuel

This control provides a fine adjustment of the fuel flow and enables the optimum flame conditions to be set for each element.

Na, K, Ca

This three-position slider control selects the correct filter for the element to be determined. When used with other filter types e.g. Li or Ba, the appropriate label should be fitted in the relevant position, on the front of the chimney assembly.

Decimal

This touch control, located adjacent to the digital display, is used to select the decimal point, e.g. using the *decimal* pushbutton to select the decimal point, a reading of 1000 will be displayed as 100.0. The sensitivity of the Model 410 is unaffected by use of this control.

Power 0/1

Rocker switch that switches the a.c. power supply on (1) and off (0). When the instrument is switched on, the *power on* LED is illuminated, and an ignition cycle is initiated. When switched off, the flame is extinguished and the a.c. supply to the instrument is switched off.

Operating Instructions continued

5.1 Front Panel Controls and Indicators continued

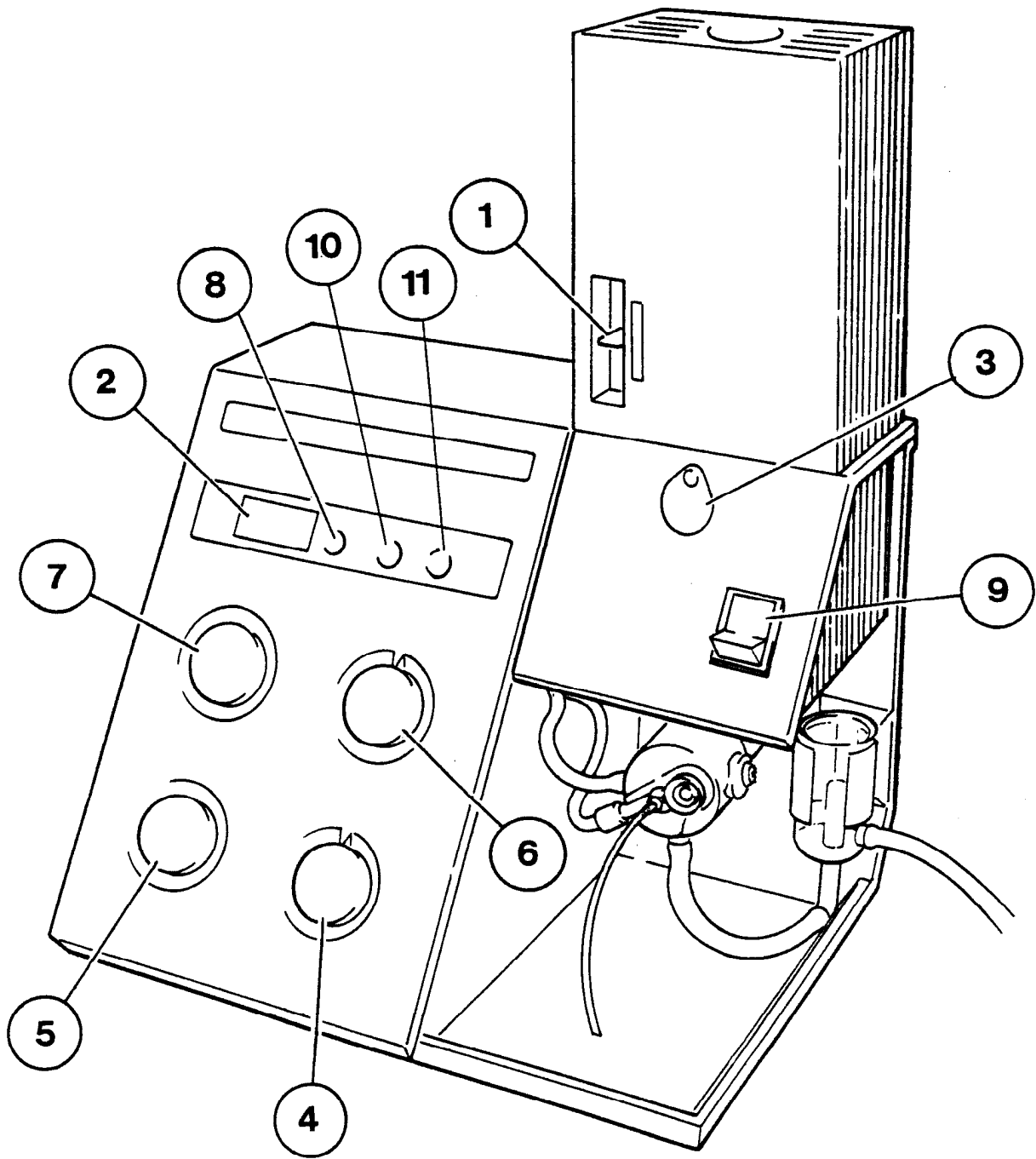

Figure 5.1 Front Panel

1. Filter selector. 2. Digital display. 3. Inspection flap. 4. Fuel adjustment control.
 5. Blank control. 6. Coarse sensitivity control. 7. Fine sensitivity control.
 8. Decimal pushbutton. 9. Power switch. 10. Power on LED. 11. Flame on LED.

Operating Instructions continued

5.2 Rear Panel Controls and Connectors

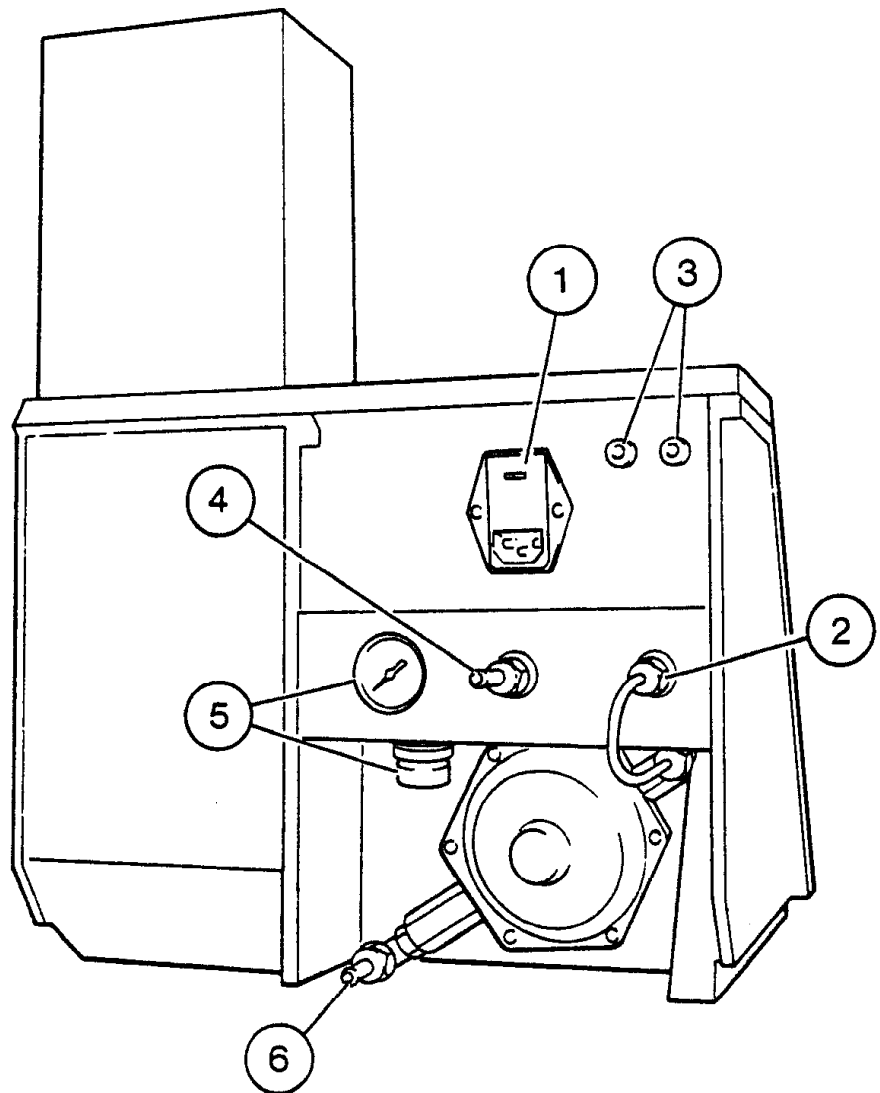

Figure 5.2 Rear Panel

- 1. Power connector and voltage selector.
- 2. Gas inlet connector.
- 3. Data output sockets.
- 4. Air inlet connector.
- 5. Air pressure gauge and air regulator adjuster.
- 6. Propane/Butane regulator inlet connector.

Operating Instructions continued**5.2 Rear Panel Controls and Connectors** continued

IEC symbol advising user to refer to accompanying documentation.
Serial Plate ~symbol denotes equipment suitable for alternating current only.

Power

Three pin connector for the a.c. supply lead incorporating a voltage selector and fuse compartment.

Data output

Two colour coded chart recorder sockets. The nominal +100mV /1000 display digits output signal is on the red socket with respect to the black socket.

Gas

1/4-inch fuel inlet connector to the instrument, permanently connected to the cylinder regulator outlet. The instrument will operate satisfactorily on Propane and Butane, or Natural Gas, using the natural gas regulator available as an optional accessory, refer to Section 9.2. See Section 4.10 for pressure and flow rate specifications.

Air

5/16-inch connector for the air inlet tubing to the instrument, from the air compressor outlet. See Section 4.11 for pressure and flow rate specifications.

Air regulator

Control to adjust the pressure of the air supply. The air pressure gauge provides a visual indication of the air pressure.

Operating Instructions continued

5.3 Initial Adjustment

NOTE The following instructions assume that the air compressor is switched on and supplying the instrument with air.

1. Check that the air pressure gauge (on the rear panel) indicates a reading between 11 and 13psig. If it does not, lower the air regulator locking ring and adjust the regulator for a reading of 1 psig on the air pressure gauge. Raise the locking ring to lock the air regulator adjuster.

WARNING The air compressor should always be switched on *before* the flame is ignited. The gas will not flow without sufficient air pressure

2. Check the Gas Trap 'U' tube is filled with water; refer to Section 2.4, paragraph 18.
3. Turn the *fuel* control fully clockwise to the closed position, but do not force it. This control is a precision assembly that will be damaged by rough handling.

WARNING Always check that the gas installation is leak-proof before initiating an ignition cycle.

4. Open the *fuel* control the required number of turns counter-clockwise as follows: -

Fuel	No. of Turns
Propane	9
Butane	11
Natural Gas	16

5. Turn on the fuel supply at source.
6. Depress the *power* switch on the front panel. The *power on* LED will illuminate, and an ignition cycle will commence.
7. If the *flame on* LED has not illuminated before the end of the ignition cycle, switch off and wait ten seconds. Then, without adjusting the fuel control, in case the instrument fuel system is not yet completely filled, switch on again to initiate another ignition cycle.
8. Repeat this cycle twice to allow sufficient time for the fuel to reach the burner then continue to paragraph 9.
9. If the *flame on* LED has not illuminated before the end of the ignition cycle, switch off the *power* switch. If using Natural Gas continue with paragraph 10. If using Propane/Butane continue with paragraph 11.
10. Remove the natural gas regulator screw cap (item 1, Figure 2.3). Rotate the screw head fully clockwise, and then counterclockwise exactly one and a half turns. Refit the screw cap.

WARNING *Do not* exceed this setting as this will lead to a very rich fuel mixture which may cause a flame to appear above the chimney.

11. Open the *fuel* control one turn counterclockwise. Switch on again.
12. If the *flame on* LED still does not illuminate, repeat paragraph 11. *Do not* open the *fuel* control more than a total of 4 turns from the settings shown in paragraph 3.
13. If the *flame on* LED still does not illuminate, switch off and refer to Section 8.2, Troubleshooting.
14. When the *flame on* LED illuminates proceed with Section 5.4, Operating Instructions, paragraph 4.

Operating Instructions continued

5.4 Operating Instructions

NOTE For greatest accuracy and stability Sherwood Scientific recommend that a batch of diluent is made up from 1 part Diluent Concentrate and 999 parts deionised or good quality distilled water. Using diluent for setting blank and for dilution of samples and standards means that all solutions presented to the instrument contain the stability promoting ingredients contained in the diluent. Always use the same batch of diluent for the blank and the dilution of samples and standards. Store the diluent in a sealed container for not more than *five* days.

WARNING Always check that the gas installation is leakproof before initiating an ignition cycle.

1. Turn on the fuel supply at source. Switch on the Air Compressor.
2. Depress the *power* switch to switch on the instrument. The *power on* LED will be illuminated, and an ignition cycle will commence.
3. If the *flame on* LED is not illuminated at the end of the ignition cycle, refer to Section 5.3 and check the setting of the *fuel* control.
4. Set the filter selector to the required position.
5. Insert the nebuliser inlet tube in a beaker containing 100ml of diluent and allow 30 minutes for the operating temperature to stabilize. This will ensure a stable burner temperature when solutions are aspirated, after the warm up period.
6. During the warm up period prepare a set of calibration solutions to cover the required measurement range. To obtain maximum linearity Sherwood Scientific recommend that the highest standard concentration does not exceed 10ppm for Na and K and 100 ppm for Ca.
7. While aspirating diluent, adjust the *blank* control so that the display reads 0.0.
8. Aspirate the highest concentration standard.
9. Allow 20 seconds for a stable reading and then adjust *coarse* and *fine* controls for a convenient reading, e.g. 20ppm Na can be set to read 20.0 on the display.
10. Carefully adjust the *fuel* control for a maximum reading on the display, ensuring that only small adjustments are made, with a pause of several seconds between adjustments.

NOTE If you have any difficulty obtaining a maximum sodium reading proceed as follows: Open the inspection flap and adjust the *fuel* control until the flame just starts to lift off the burner. Then turn the *fuel* control back, counterclockwise, until the cones of the flame are on the burner. Close the flap and proceed with paragraph 11.

11. Remove the standard solution, wait 10 seconds, then aspirate a blank solution of diluent for 20 seconds. Adjust the *blank* control for a 0.0 reading. Remove the blank solution and wait 10 seconds.
12. Repeat paragraphs 8, 9 and 11 until the blank reading is 0.0 (within ± 0.2) and the calibration reading is within $\pm 1\%$. If a chart recorder is being used set zero on the blank solution and set span while aspirating the calibration standard.
13. Without touching the fine and coarse controls aspirate each of the remaining calibration standards for 20 seconds (starting with the lowest concentration to avoid carry over) again allowing 10 seconds between measurements. Note the value of each standard and plot the results on a graph against standard concentration on linear graph paper. Refer to example shown in Figure 5.3.

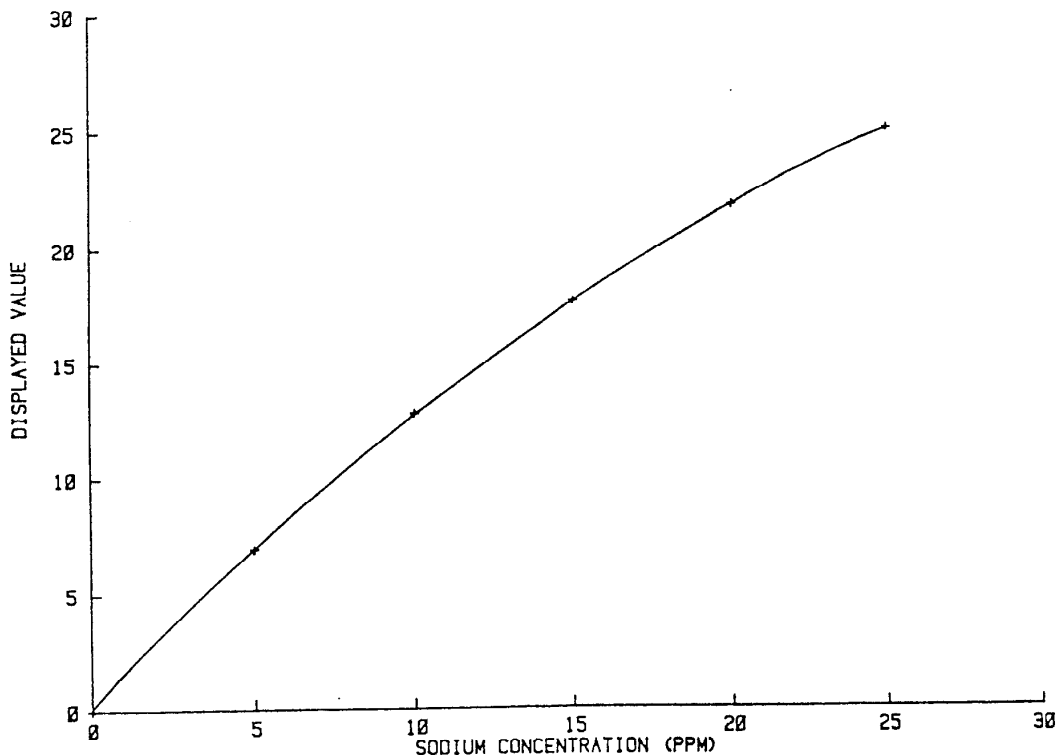
Operating Instructions continued**5.4 Operating Instructions** continued**Figure 5.3 Typical Calibration Curve**

14. Check calibration standards and blank readings.
15. Dilute the unknown solutions with diluent to give a concentration of the element under test within the range of the calibration standards. Several attempts might be necessary to determine the correct dilution ratio.
16. Aspirate each of the diluted unknowns for 20 seconds, then note the reading. The concentration of the element in the unknown sample can be calculated by reading the sample concentration from the calibration curve and multiplying it by the dilution factor.
17. Recalibrate the instrument by carrying out paragraphs 8 to 12. Experience in use will determine how frequently the calibration needs to be checked.

Operating Instructions continued

5.5 Shutdown Procedure

1. Aspirate Cleaning Solution diluted 1 in 100 with deionised water, for one minute.
2. Aspirate diluent for two minutes.
3. For a short-term shutdown (two hours) switch off the instrument *power* switch and switch off the compressor.
4. For a longer term shutdown (overnight) turn off the fuel supply at source. When the *flame on* LED is extinguished, switch off the *power* switch, and the compressor. This ensures that the fuel pressure in the fuel tubing is at a minimum.

5.6 Operating Hints

1. The deionised or high quality distilled water used when making a batch of diluent must be free from contaminating elements. It is recommended that the same batch of diluent is used to prepare all solutions and to set blank on the instrument.
2. Greatest accuracy will be obtained by using the same dilution equipment for both standard and sample preparation.
3. Always use suitable standards for calibrating the instrument. Remember that the accuracy of the results obtained from the Model 410 depend on the accuracy and purity of the calibration standard that is used.
4. The nebuliser is a precision assembly, contributing more than any other single item to the effectiveness of your Flame Photometer. To keep it in good condition, it is essential that it is flushed with distilled water after use. This ensures that no solid matter remains in the assembly. If this procedure is carried out regularly no difficulties should be experienced.
5. Applications and Method Sheets are available from your Sherwood Scientific distributor or www.sherwood-scientific.com.
6. A guide to Flame Photometry is available from your Sherwood Scientific Distributor.

6

Operational Precautions and Limitations

6.1 General

1. Always dilute samples and standards with the same batch of diluent (made up of 1 part Diluent Concentrate and 999 parts of deionised or good quality distilled water), which contains non-ionic wetting agents.
2. The samples should not be highly viscous or non-homogeneous. If possible, samples likely to contain sediment should be filtered and then mixed to obtain a representative result.
3. Always use soap solution when checking for leaks in fuel or air lines. Do not allow fuel to flow in the presence of unguarded flames, e.g. cigarettes.
4. Always use genuine Sherwood Scientific replacement parts. Do not, for example, replace the 'U' tube with one of different material, bore or length as this will cause a deterioration in the instrument's performance.
5. Always carry out the maintenance schedules as detailed in Section 7.
6. *Do not* leave the inspection flap open, unless adjusting flame conditions, as this will allow stray light to enter the chimney.
7. The front panel of the Model 410 is impervious to a wide range of chemicals. However, strong acids and some organic solvents e.g. chloroform and phenol, may affect the finish. Any spillage should be thoroughly wiped away as soon as possible. If necessary, clean the instrument with warm, soapy water - *do not* use abrasives.

6.2 Hazards

1. All electrical instruments are potentially hazardous. With the exception of the glass chimney, there are no user maintainable parts inside the Model 410 covers. Never remove covers from the instrument, unless specific maintenance instructions are being followed.
2. Propane, butane and natural gas are highly inflammable and potentially explosive gases. Propane and butane are stored as a liquid, under pressure in a cylinder, for use with the Model 410. Such a cylinder should never be subjected to heat or mechanical shock. When handled correctly and connected to the instrument as instructed, the fuel gas is quite safe. Check hosing joints with a soap solution before allowing any naked flame in the vicinity. Never open a cylinder valve to atmosphere even on a supposedly empty cylinder.
3. The chimney cap and glass chimney and the area above the chimney can become very hot and are capable of causing severe burns. *Never view the flame from the top of the chimney, always use the inspection hole.*
4. Make sure that the air compressor is connected to the power supply and switched on before starting a flame ignition sequence. Failure to observe this precaution may result in a build up of fuel gas, which will cause a flame to appear above the chimney.

7

Maintenance

7.1 General

Under the Daily, Weekly, Monthly and Six-Monthly Maintenance headings are summaries of the work and equipment required. The tasks are detailed from Section 7.6 onwards.

For maintenance of the air compressor, dilutor and chart recorder, if used, refer to the instructions supplied with the equipment.

7.2 Daily Maintenance

EQUIPMENT REQUIRED: - *None.*

1. Empty waste container, if used.
2. Check air line for condensation, and drain if necessary.
3. Check 'U' tube is filled with deionised water.
4. Rinse nebuliser with distilled water after use.

7.3 Weekly Maintenance

EQUIPMENT REQUIRED

10 ml beaker; Stop watch; Nebuliser cleaning wire; Deproteinising Solution; Nebuliser tube and sleeve, or polythene inlet tube, as required.

1. Carry out Daily Maintenance procedure.
2. Deproteinising the system (Section 7.10).
3. Check the operation of the nebuliser (Section 7.6).

7.4 Monthly Maintenance

EQUIPMENT REQUIRED

As for weekly maintenance.

1. Carry out Daily and Weekly Maintenance procedures.
2. Check the constant head drain, mixing chamber, 'U' tube and drain tube and clean if necessary (Section 7.7). Check that the 'U' tube is refilled with deionised water on reassembly.

Maintenance continued**7.5 Six-Monthly Maintenance**

EQUIPMENT REQUIRED

As for weekly maintenance, plus the following: -

'U' tube and drain tube, Methanol; tissues; Soft lint free cloth; Cotton buds.

1. Carry out the Daily and Weekly Maintenance procedures.
2. Clean the mixing chamber, burner tube, burner and constant head drain (Section 7.7).
3. Replace nebuliser tube and sleeve, 'U' tube and drain tube.
4. Clean the optical filters and the glass chimney (Section 7.8).
5. Check the air and fuel tubing and connectors for leaks, using soap solution. Check for signs of stress cracking especially at the connectors.

7.6 Nebuliser

EQUIPMENT REQUIRED

Stop watch; 10 ml beaker; Cleaning wire; Cleaning Solution;

Stainless steel nebuliser tube and sleeve, or polythene inlet tube, as required.

Operational Check

1. Turn off the fuel supply at source.
2. Switch on the M410 and the air compressor. Check that the *flame on* LED is off.
3. Fill the beaker with deionised water, and weigh it.
4. Present the 10ml beaker of deionised water to the nebuliser tube for an accurately timed minute.
5. Reweigh the beaker and calculate the aspiration rate. If it is between 2 and 6 ml/minute, no further action is required. If it is too low, continue with paragraph 6. If it is too high contact your Sherwood Scientific Distributor. Do not attempt to adjust the nebuliser, as the capillary position is fixed during manufacture, and is not adjustable.

Cleaning the Nebuliser

6. Release the nebuliser retainer (item 1, Figure 7.1) and withdraw the nebuliser (item 2, Figure 7.1).
7. Insert a cleaning wire into the nebuliser capillary, and pull right through.
8. Remove the nebuliser and, with a finger placed over the outlet nozzle, turn on the air supply to force any residue out of the capillary tube.
9. Repeat steps 7 and 8 until the aspiration rate is constant and between 3 and 6 ml/minute.
10. Replace the nebuliser and rinse with distilled water.
11. Check the nebuliser inlet tube for blockage and damage, repair or replace as appropriate.

Note: - Before despatch each nebuliser is adjusted for optimum performance. This adjustment is critical and under no circumstances should you attempt to readjust or dismantle the assembly. If adjustments are made to the atomiser we shall not accept responsibility for poor performance from your Flame Photometer.

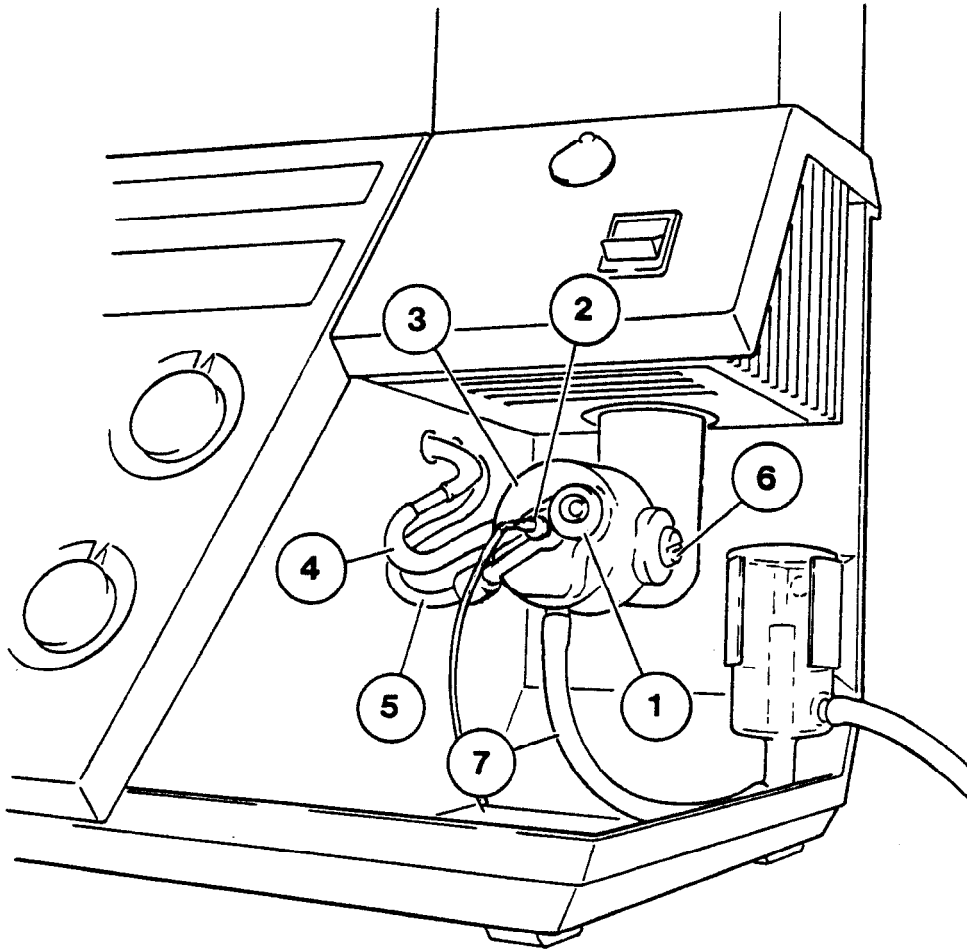
Maintenance continued**Cleaning the Nebuliser** continued**Figure 7.1** Mixing Chamber

1. Nebuliser retainer. 2. Nebuliser. 3. End cap. 4. Fuel tubing. 5. Air tubing.
6. End cap securing screw. 7. 'U' tube.

12. Fit a new length of nebuliser inlet tubing to the nebuliser. Recheck the aspiration rate, paragraphs 3, 4, and 5.
13. If nebuliser operation is still outside the specification, unscrew the air line connector and remove the nebuliser inlet tubing.
14. Soak the nebuliser in a 1 in 100 dilution of Cleaning Solution, agitating it periodically.
15. Rinse thoroughly in deionised water and shake dry.
16. Refit the nebuliser inlet tubing and the air line. Recheck aspiration rate.
17. If the nebuliser operation is still unsatisfactory, fit a new nebuliser. Do not attempt to adjust the nebuliser, as the capillary position is fixed during manufacture, and is not adjustable.

Maintenance continued**7.7 Cleaning the Mixing Chamber, Burner and Drain**

EQUIPMENT REQUIRED

Flat blade screwdriver, blade width 8 mm; Deproteinising Solution; Tissues.

1. Check that the *flame on* LED is off, fuel is turned off at source, and the instrument and compressor are switched off.
2. Release the nebuliser retainer and withdraw the nebuliser (items 1 and 2, Figure 7.1).
3. Disconnect the fuel tubing (item 4, Figure 7.1) from the end cap connector (item 3, Figure 7.1) using a twisting movement. *Do not* pull the tubing, as this will make it grip the connector more tightly.

WARNING Use a heat resistant glove when handling the burner and burner tube if the flame has been alight within the preceding 30 minutes. Do not proceed until all the parts within the chimney are at a safe handling temperature.

4. Remove the chimney cover and lift out the glass chimney.
5. Disconnect the mixing chamber from the chimney assembly by twisting it to the right, through 40 degrees. Lower the mixing chamber and burner assembly.
6. Lift the burner tube from the mixing chamber and remove the burner.
7. Unscrew the end cap securing screw (item 6, Figure 7.1). Grasp the end cap (item 3, Figure 7.1) and remove it from the mixing chamber, with a slightly twisting action. Lift the end cap to allow the water in the 'U' tube to flow into the constant head drain. Disconnect the 'U' tube from the end cap and constant head drain.
8. Unclip the constant head drain and disconnect the drain tube.
9. Soak all the items removed from the instrument in a 1 in 100 dilution of Cleaning Solution, agitating it periodically.
10. Rinse the parts thoroughly in deionised water and dry with clean tissues.
11. Fit the burner tube to the mixing chamber, ensuring that the locating slot in the burner tube engages with the locating pin in the mixing chamber.
12. Fit the burner *pointed end downwards* into the burner tube. Rotate the burner to ensure that it is fully inserted.
13. Check the condition of the end cap 'O' ring seal. If necessary, replace the seal.
14. Replace the end cap, using a twisting movement. Align the hole with the mixing chamber screw fixing. Fit the screw (item 6, Figure 7.1).
15. Carefully position the mixing chamber, with the burner tube inside the chimney. With the burner tube fully inserted, twist the mixing chamber to the left, through 40 degrees, to lock it in position.
16. Refit the glass inner chimney and the chimney cover
17. Fit the constant head drain to the spring clip and position it so that the lip on the drain is resting on the spring clip.
18. Connect the fuel tubing to the mixing chamber end cap. Connect the 'U' tube between the mixing chamber end cap and the constant head drain. Fit the drain tube to the constant head drain.
19. Fit the nebuliser into the end cap and position the retainer to lock it.
20. Use a wash bottle to fill the 'U' tube with deionised water. Sufficient water should be used to completely fill the 'U' tube and purge it of air.

Maintenance continued**7.8 Cleaning the Optical Filters and Glass Chimney**

EQUIPMENT REQUIRED

Soft lint free cloth; Methanol; Cotton buds; Tissues; Cleaning Solution.

1. Check that the *flame on LED* is off, fuel is turned off at source, and the 410 and compressor are switched off.

WARNING Do not proceed until all the parts within the chimney are at a safe handling temperature.

2. Lift off the chimney cap from the chimney assembly. Lift out the glass chimney.
3. Move the filter selector to the top position, and push the lever upwards and to the right. This will disengage the filter selector from the stop. Lift the filter selector out of the chimney.
4. Position the filter selector on the lint free cloth so that the coloured sides of the filters are uppermost and the thumb grip is at the top, as shown in Figure 7.2.

CAUTION Handle the optical filters only by the edges, *never* the faces.

5. Using a soft probe, (cotton bud or similar), that will not scratch the filters, push out the first filter. Examine the filter edges and note the wavelength on Figure 7.2, alongside the appropriate space. Remove the remaining two filters and mark the wavelengths on Figure 7.2.
6. Carefully wipe each filter with a cotton bud soaked in methanol.
7. Turn the filter selector over so that the large holes and filter retainers are uppermost.
8. Refer to Figure 7.2 and carefully replace the filters, mirrored sides upward, into their respective positions.
9. Refit the filter selector into position inside the chimney and slide it fully in. Check that all three positions can be selected.

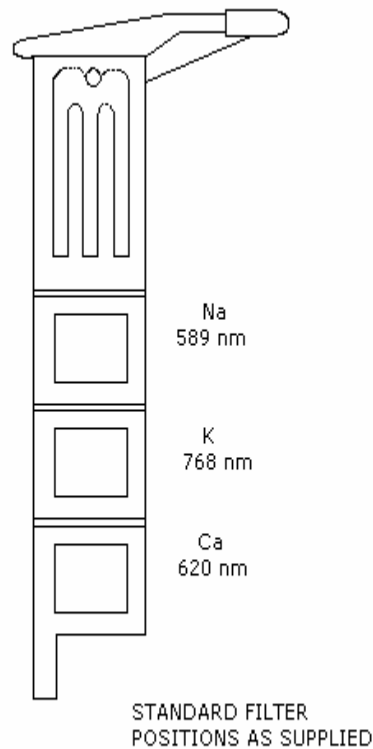
Maintenance continued**7.8 Cleaning the Optical Filters and Glass Chimney** continued**Figure 7.2 Filter Selector**

10. Soak the glass chimney in a 1 in 100 dilution of Cleaning Solution, agitating it periodically.
11. Rinse the glass chimney thoroughly in deionised water and dry with clean tissues.
12. Replace the glass chimney *with the clear strip at the bottom*. Make sure the glass chimney is seated correctly and refit the chimney cap on top of the chimney.

Maintenance continued**7.9 Voltage Selection and Fuse Replacement**

EQUIPMENT REQUIRED

Fuses.

WARNING For continued protection against fire hazard use only the same type and rating of fuse that was fitted originally to the M410 refer to instrument rear panel.

1. Check that the *flame on* LED is off, fuel is turned off at source, and the instrument and compressor are switched off.
2. Disconnect the a.c. supply lead from the a.c. supply socket.
3. Disconnect the a.c. supply lead from the *power* connector on the rear panel.
4. Open the voltage selector compartment and withdraw the voltage selector, item 1, Figure 7.3. To replace fuses continue with paragraph 5; to change the operating voltage continue with paragraph 7.
5. Slide out the two fuse holders, item 2, Figure 7.3, and remove the fuses.
6. Replace any burned out fuses and slide in the fuse holders.
7. Replace the voltage selector so that the required voltage setting is visible through the window of the compartment cover. Close the compartment cover and refit the a.c. supply lead.

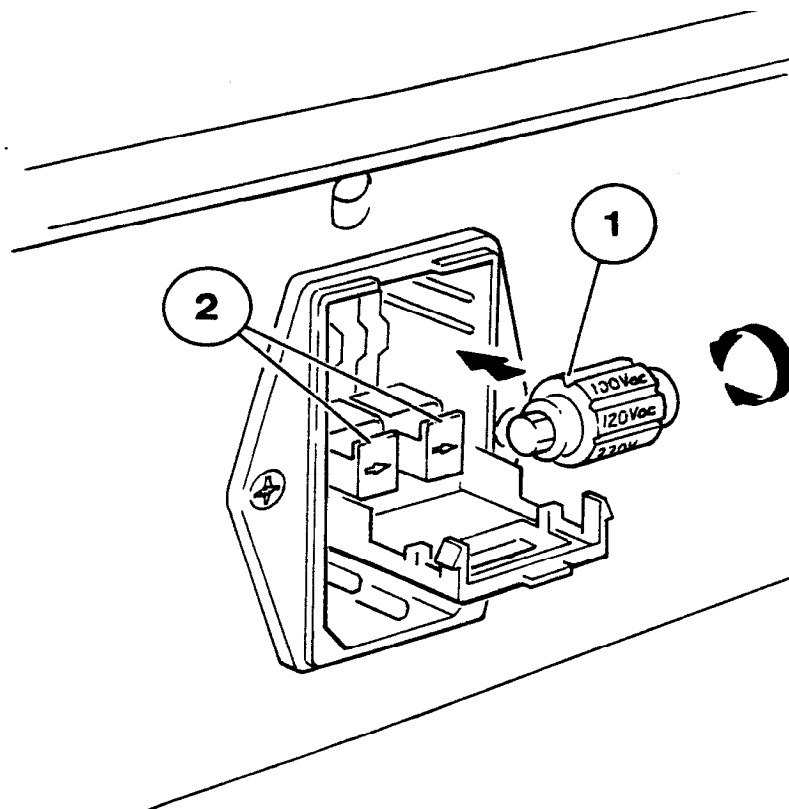

Figure 7.3 Voltage Selector and Fuse

1. Voltage selector. 2. Fuse holders

Maintenance continued

7.10 Deproteinising or Disinfecting Procedure

NOTE To deproteinise the system use Deproteinising Solution, to disinfect the system use Tubing Disinfectant.

EQUIPMENT REQUIRED

Deproteinising Solution or Tubing Disinfectant.

1. Light the flame as detailed in Section 5.4.
2. Present a beaker of Deproteinising Solution or Tubing Disinfectant to the nebuliser for 10 minutes.
3. After 10 minutes have elapsed, replace the beaker of solution with a beaker of deionised water. Flush the system for two minutes.
4. Shutdown the instrument as detailed in Section 5.5.

8

Troubleshooting

8.1 Power on LED not illuminated

Check that the instrument is connected to a working a.c. supply, and that the power switch is depressed.

Check the plug fuse and replace if necessary. Check the instrument fuses and replace if required, refer to Section 7.9.

If fault persists contact your Sherwood Scientific Distributor.

8.2 Flame on LED not illuminated

General

Ensure that the 'U' tube is filled with deionised water, refer to Figure 2.4.

Burner must be fitted with pointed end downwards, refer to Section 7.7.

Air Supply

Air compressor must be connected to an a.c. supply, and working correctly.

Check the air tubing connections from the air compressor to the instrument, refer to the air compressor manual.

Fuel Supply

There must be a compressed air flow otherwise the air pressure switch will not allow the gas to flow into the instrument.

Check that there is an adequate supply of fuel.

Fuel supply must be turned on at source. If using a long length of fuel tubing, try repeating the ignition sequence a few times to allow the fuel to fill the tubing.

If using natural gas, check the setting of the natural gas regulator, refer to Section 5.3.

If the fuel is propane or butane check that the regulator at the cylinder is adjusted for 2.1kg/cm² (30psig).

Check the fuel control is set correctly, refer to Section 5.3.

If the fuel restrictor (propane/butane only) is blocked, clean with the nebuliser cleaning wire, refer to Figure 2.1. If fault persists contact your Sherwood Scientific Distributor.

Troubleshooting continued**8.3 Unable to set display to zero**

Check that diluent is being aspirated.

The deionised water supply may be contaminated, use a better grade of deionised water.

The burner may be encrusted with salt deposits. Clean the burner as detailed in Section 7.7.

If using a chart recorder check that the data output connections are correct.

If fault persists contact your Sherwood Scientific Distributor.

8.4 Unable to set display to standard reading

Check the concentration of the standard being aspirated, and that the dilution ratio of this standard is correct.

Use fresh deionised water and recalibrate zero. If using low-grade deionised water the background levels may be too high.

Make sure the correct filter has been selected. If there is a chance that the optical filters may have been serviced, check that they have been fitted correctly, refer to Section 7.8.

The nebuliser may be blocked. Check the nebuliser, refer to Section 7.6.

Check the glass chimney is clean, refer to Section 7.8.

Make sure the fuel control is set correctly, refer to Section 5.3.

If the atmosphere surrounding the instrument, or air compressor inlet, is contaminated (e.g. smoke) incorrect readings may result.

If fault persists contact your Sherwood Scientific Distributor.

8.5 Unstable results

Do not use compressed air from a “communal” source or “Air Line” as this may be contaminated with oil, which will ruin the performance of the Model 410. Use a dedicated Compressor such as the Sherwood Model 851 or Model 855.

Check the concentration of the solutions being aspirated. The solutions should all contain 1 in 1000 dilution of Diluent Concentrate, refer to Section 5.4.

Check the fuel supply is adequate. Make sure the fuel control is set correctly, refer to Section 5.3.

The use of Natural Gas from a “communal source” will fluctuate as other users turn on or turn off their gas taps. Wherever possible, use bottled gas.

The nebuliser may be blocked. Check the nebuliser, refer Section 7.6.

The ‘U’ tube or drain tubing may be blocked or partially obstructed.

If the air supply tubing show signs of condensation, drain the air tubing. If this problem recurs frequently use a Model 856 air compressor with water separator.

Make sure the air compressor filter is changed regularly, refer air compressor manual.

If the atmosphere surrounding the flame photometer, or air compressor inlet, is contaminated (e.g. smoke) unstable readings may result. A similar effect may be observed if the instrument is sited in a draught. If fault persists contact your Sherwood Scientific Distributor.

Troubleshooting continued

8.6 Non-linear results

Check the concentration of the solutions being aspirated. The solutions should all contain 1 in 1000 dilution of Diluent Concentrate, refer Section 5.4. Make up fresh solutions and recheck calibration curve.

Check that the fuel supply is adequate. Make sure the fuel control is set correctly, refer Section 5.3.

The nebuliser may be blocked. Check the nebuliser, refer Section 7.6.

The 'U' tube or drain tubing may be blocked or partially obstructed.

Use fresh deionised water and recalibrate zero. If using low-grade deionised water the background levels may be too high.

If fault persists contact your Sherwood Scientific Distributor.

9

Spares and Accessories

9.1 Ordering Information

When ordering spares or accessories for your instrument, please give the following information to your Sherwood Scientific distributor.

Instrument Serial No.

Catalogue No. of Part (Cat. No.)

Description

Quantity required

This will ensure that your order is dealt with quickly and efficiently.

The number shown in the third column (Quantity) is the quantity of items that are supplied against the stated Catalog Number. If the quantity is greater than 1, then only multiples of that quantity can be supplied.

9.2 Spares and Accessories

Serial Number	Item	Quantity
420 08 102	Nebuliser	1
410 26 001	Mixing chamber and burner	1
402 12 001	End Cap Assembly	1
400 02 013	Retainer, End Cap	1
410 04 010	Constant Head and Drain	1
001 48 105	Fuse, 200mA, slo-blo	1
400 22 003	Tube, Nebuliser Inlet	1
400 20 001	Fuel restrictor	1
410 19 002	Natural gas regulator kit with filter	1
001 26 033	Sample pot, plastic, in packs of 50	1 pack
989 05 137	Sodium filter, 589.6nm	1
989 05 138	Potassium filter, 768nm	1
989 05 139	Lithium filter, 671nm	1
400 16 004	Calcium filter, 620nm, with label	1
400 16 005	Barium filter, 520nm, with label	1
410 27 001	Caesium in Holder	1
410 27 002	Rubidium in Holder	1
410 27 003	Strontium in Holder	1
410 21 001	Filter holder (recommended for use with Ca and Ba filters)	1
001 08 234	Propane primary regulator, cylinder fixing	1

Spares and Accessories continued

Serial Number	ITEM	QUANTITY
001 08 439	Butane primary regulator (182H) for 32lb Calor/Caravan cylinder	1
001 08 732	Butane primary regulator for 'Gaz' type cylinder	1
001 72 114	Fuel tubing	per metre
001 72 116	Air tubing	per metre
001 08 718	'Unex' tubing clamp	1
100 99 010	Nebuliser cleaning wire, pack of 3	1 pack
851 01 001	Model 851 Air Compressor	1
855 01 001	Model 855 Air Compressor, complete with water separator	1
410 89 001	Service Manual	1
475 41 100	Model 805 Dilutor	1
471 71 900	Mains Supply Lead	1
001 26 074	Disposable sample cups, 1,5ml, pack of 1000	1 pack
001 26 033	Disposable sample cups, 25ml, pack of 50	1 pack
001 92 492	Guide to Flame Photometry	1

9.3 Standard Solutions

NOTE The following solutions are available.

CAT. NO.	DESCRIPTION	QUANTITY
001 56 620	Flame Photometer Standard, 1000ppm Na	6 x 100ml
001 56 621	Flame Photometer Standard, 1000ppm K	6 x 100ml
001 56 622	Flame Photometer Standard, 1000ppm Li	6 x 100ml
001 56 623	Flame Photometer Standard, 1000ppm Ca	6 x 100ml
001 56 184	Cleaning Solution, 500ml	1 bottle
001 56 681	Diluent Concentrate	6 x 100ml
001 56 682	Tubing Disinfectant,	6 x 100ml
001 56 183	Deproteinising solution, 80ml, pack of 6	1 pack

Appendix A

Bibliography

Reference

1. Kolthoff, I.M., Z. Anal. Chem. 70 397 1927
2. Shohl, A.T., and Bennett, H.B. J. Biol. Chem. 78: 643 1928
3. Hald, P.M., J. Biol. Chem. 167. 499. 1947
4. Bernstein, R.E., S.Afr. J. Med. Sci. 17. 101, 1952
5. Alkemade, C.T.J., Smit J. and Verschure J.C.M. Biochimica et Biophysica Acta. 8. 562. 1952
6. Collins G.C. and Polkinthorne H., The Analyst, 77, 917 pp. 430-436, 1952
7. Dryer, R.L., Clin. Chem. 2. 112. 1956
8. Puffeles, M. and Nessim, N.E., The Analyst. 82. 976, 1957
9. Boling, E.A., J. Lab and Clin. Med. 63, 501 1964
10. Amdisen, A., Scand J. Clin. and Lab. Invest. 20 (2) 104. 1967

Appendix B

Model 410C

Addendum - Using the M410 Flame Photometer on Clinical Samples

These sections are replacement sections to those in the Main M410 Instruction Manual and should be read in conjunction with it.

1 Introduction

The Sherwood Model 410 Flame Photometer can be used for clinical samples: - serum, plasma and urine.

Sherwood can provide two accessories, which makes these measurements easier to carry out: -

Clinical samples have high Sodium and Potassium concentrations, which require significant dilution, 1 in 200. Sherwood can supply a Continuous Flow Dilutor, the Model 805, which performs this dilution automatically and can be directly connected to the Flame Photometer.

Even then the level of Sodium concentration is beyond the normal linear range of any flame photometer. This usually means that a range of standards has to be made up and a curve plotted which is then used to determine the actual Sodium level of a sample.

Sherwood can provide a Lineariser which electronically adjusts the display according to well understood principles so that all levels of Sodium concentrations fall within the linear range of the instrument and only one standard and the zero value is required.

2.3 Unpacking List

substitute: -

	00156100	140 Na, 5.0 K, 1.5 Li Standard x 100ml
for	00156620	1000ppm Standard Na x 100ml x6
	00156621	1000ppm Standard K x 100ml x6
	00156623	1000ppm Standard Ca x 100ml x6

a) Fitting a Lineariser (Refer to figure 2.7 attached)

The lineariser will normally arrive already installed in your instrument provided you have ordered a Model 410C, in which case you can ignore this section).

- ai Identify the Lineariser, which may be packed separately.
- aii Remove the Logo Plate from the front of the instrument by carefully prising off one end of the plate with a flat bladed screwdriver.
- aiii Check the alignment of the Lineariser Module pins with the 5 sockets on the main printed circuit board, which is revealed behind the logo plate. Push home the pins and replace the logo plate.

Appendix B continued

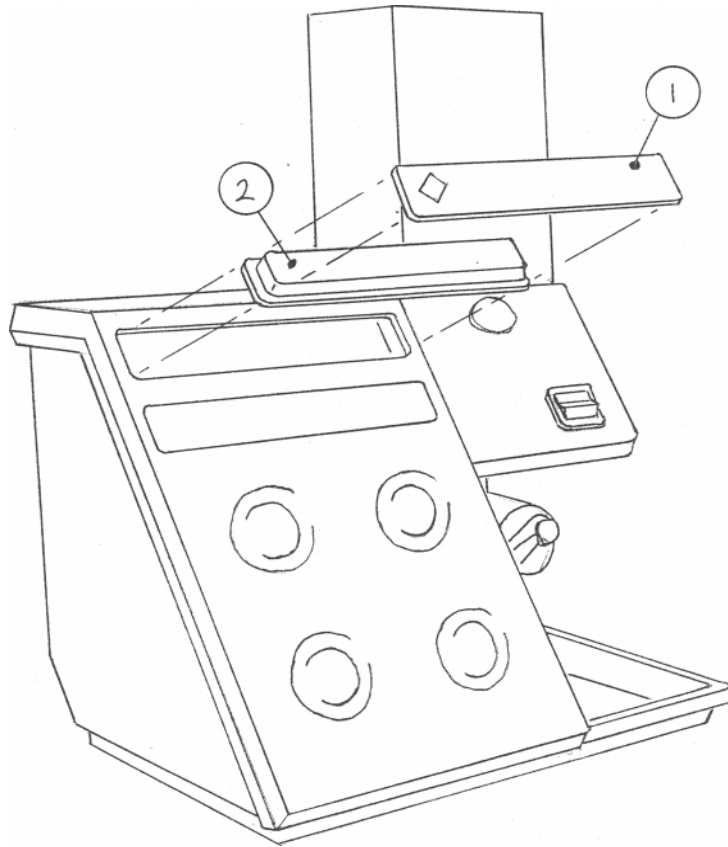

Figure 2.7

- 1. Logo Plate
- 2. Lineariser Module

b) Measurement Ranges for clinical samples

Na serum	110-170mmol/l
Na Urine	0-200mmol/l
K serum	0-10.0mmol/l
K urine	0.200mmol/l
Li serum	0-3.0mmol/l

These are concentrations in the original samples *before* dilution.

Appendix B continued**c) Specificity****Na Range**

Errors in the Na readings due to Ca, K, Li presence in biological samples shall not be greater than 1mmol/l where the levels of those elements do not exceed 3.5mmol/l Ca, 100mmol/l K and 2.0mmol/l Li.

K Range

Errors in the K readings due to Ca, Na, Li presence in biological samples shall not be greater than 1mmol/l where the levels of those elements do not exceed 3.5mmol/l Ca, 180mmol/l Na and 2.0mmol/l Li.

Li Range

Errors in the Li readings due to Ca, Na and K presence in biological samples shall not be greater than 1mmol/l where the levels of those elements do not exceed 3.5mmol/l Ca, 180mmol/l Na and 8.0mmol/l K.

d) Accuracy**Linearity**

Na serum	±2mmol/l
Na Urine	±4mmol/l
K serum	±0.2mmol/l
K urine	±2mmol/l
Li serum	±0.2mmol/l

The linearity specification is subject to ±1 significant digit for display resolution and may not be achieved for results outside the measurement ranges specified above.

Drift

Na serum/urine	better than 4mmol/l
K serum	better than 0.2mmol/l
K urine	better than 4mmol/l
Li serum	better than 0.1mmol/l

These can be obtained measured over 5 minutes based on a run of 10 consecutive samples aspirated for 20 seconds then 10 seconds of air. They are valid up to the maximum measurement range of the instrument.

Reproducibility

Na (140mmol/l)	better than 1.5% CV
K (5.0mmol/l)	better than 1.5% CV
K (80mmol/l)	better than 1.5% CV
Li (2.5mmol/l)	better than 2.5% CV

Results obtained from 20 replicates of the same sample aspirated for 20 seconds then 10 seconds of air.

Appendix B continued**e) Sample requirement****Serum plasma urine C.S.F. and sweat.**

Method of presentation: -

The sample is either diluted using the following factors into a sample cup and is presented directly to the nebuliser inlet tube; or it is diluted using the Model 805 Dilutor, which is connected to the Model 410 via a weir cup assembly supplied with the Dilutor.

Sample	Dilution Factor	Min Volume manual dilution	Min volume using M805
Na serum/urine	1:200	10µl	50µl
K serum	1:200	10µl	50µl
K urine	1:100	10µl	50µl see note
Li serum	1:10	50µl	N/A

Note: - For Potassium in urine the samples must be pre-diluted 1:5 before using the M805.

Note: - For Lithium determinations the blank solution should contain normal levels of Na, K and Ca to suppress the effect of interference from these elements in the Lithium samples.

5.4 Operating Instructions

While waiting for the flame to warm up prepare diluted standard and solutions prepared in accordance with the dilutions described in 'e' above.

With the Lineariser fitted it is only necessary to prepare a single standard at the expected sample concentration level.

Set the zero control to show 0 on the display while aspirating the blank solution (containing other elements if measuring Lithium see notes 'e' above).

Set the display to the value of the undiluted standard e.g. 140mmol/l Na while aspirating the diluted standard.

Repeat until values are obtained within $\pm 1\%$.

Aspirate sample and note reading on the display, which will be the value of the concentration of the undiluted sample.

5.5 Shutdown

- 1 Aspirate Deproteinising solution diluted 1:100 with deionised water for 1 minute.
- 2 Then aspirate diluent solution for two minutes.

Appendix B continued**6.2 Hazards****WARNING**

When the Model 410 is used in a pathology laboratory cleaning of component parts such as the nebuliser, mixing chamber, burner parts, drain tubing and vessels should be carried out very carefully using protective clothing, gloves and eye guards. Refer to section 7.10.

All items should be treated as though they contain pathogenic organisms.

9 Spares and Accessories

Serial Number	Description
47541100	Model 805 Automatic Dilutor
47829800	Lineariser

Solutions**Clinical Solutions**

00156100	Bottle containing 100ml of following concentrations: Na 140mmol/l K 5.0mmol/l Ca 0.0mmol/l Li 1.5mmol/l
47852300	Pack 50 Ampoules containing 2ml of following concentrations: Na 160mmol/l K 80.0mmol/l Ca 0.0mmol/l Li 0.0mmol/l
00156183	Deproteinising Solution pack 6 x 80ml

Sherwood Scientific Limited

Warranty Statement

Product Warranty

Serial Number _____

Warranty Term: **12 Months**

Sherwood Scientific warrants, subject to the conditions itemised within this document, through either Sherwood Scientific personnel or personnel of its authorised distributors, to repair or replace free of all charges, including labour, any part of this product which fails within the warranty time specified above, appertaining to this particular product. Such failure must have occurred because of a defect in material or workmanship and not have occurred as a result of operation of the product other than in accordance with procedures described in the instructions furnished with this product.

Conditions and specific exceptions that apply to the above statement are as follows:

1. End-user warranty time commences on the date of the delivery of product to end-user premises.
2. 'Free of all charges' statement applies only in areas recognised by Sherwood as being services either directly by its own personnel, or indirectly through personnel of an authorised distributor. Products purchased outside these areas requiring service during the warranty period will incur charges relative to the travel/transit costs involved. However, products purchased in such areas will be serviced during the warranty period free of all charges providing they are returned, carriage paid, to either Sherwood or by pre-arrangement to an authorised Sherwood distributor.
3. All maintenance (other than operator maintenance as described in the instructions), repairs or modifications have been made by Sherwood or Sherwood authorised personnel.
4. This product has where applicable been operated using Sherwood specified supplies and reagents.
5. Sherwood reserves the right to make any changes in the design or construction of future products of this type at any time, without incurring any obligation to make any changes whatsoever to this particular product.
6. Reagents, supplies, consumables, accessories and user maintenance items are not included in this warranty.

Warranty Statement (continued)

7. Repairs or replacement of any part failing due to abnormal conditions including the following, are excluded from this warranty:
 - a. Flood, lightning, earthquake, tornado, hurricane, or any other natural or man-made disaster.
 - b. Fire, bombing, armed conflict, malicious mischief or sprinkler damage.
 - c. Physical abuse, misuse, sabotage or electrical surge.
 - d. Damage incurred in moving the product to another location.

8. User agrees to permit Sherwood personnel or personnel of its authorised distributor to make changes in the product which do not affect results obtained, but do improve product reliability.

Representations and warranties purporting to be on behalf of Sherwood Scientific made by any person, including distributors and representatives of Sherwood, which are inconsistent or in conflict with the terms of this warranty (including but not limited to the limitations of the liability of Sherwood as set forth above), shall not be binding upon Sherwood unless reduced to writing and approved by an officer of Sherwood Scientific.

Except for the obligations specifically set forth in this warranty statement, in no event shall Sherwood Scientific Limited be liable for any direct, indirect, special, incidental, or consequential damages, whether based on contract, tort or any other legal theory and whether advised of the possibility of such damages.

Neither Sherwood nor any of its third party suppliers makes any other warranty of any kind, whether expressed or implied, with respect to Sherwood Products.

Sherwood Scientific Ltd.,
1 The Paddocks,
Cherry Hinton Road,
Cambridge,
CB1 8DH,
England