

# **GSA 8X/GSM 85(A) Installation Manual**



© Copyright 2005 - 2007  
Garmin Ltd. or its subsidiaries  
All Rights Reserved

Except as expressly provided herein, no part of this manual may be reproduced, copied, transmitted, disseminated, downloaded or stored in any storage medium, for any purpose without the express prior written consent of Garmin. Garmin hereby grants permission to download a single copy of this manual and of any revision to this manual onto a hard drive or other electronic storage medium to be viewed and to print one copy of this manual or of any revision hereto, provided that such electronic or printed copy of this manual or revision must contain the complete text of this copyright notice and provided further that any unauthorized commercial distribution of this manual or any revision hereto is strictly prohibited.

Garmin International, Inc.  
1200 E. 151st Street  
Olathe, Kansas 66062 U.S.A.  
Aviation Dealer Technical Support Line (Toll Free): (888) 606-5482  
Web Site Address: [www.garmin.com](http://www.garmin.com)  
E-mail: [avionics@garmin.com](mailto:avionics@garmin.com)

Garmin (Europe) Ltd  
Liberty House  
Bulls Copse Road  
Hounslow Business Park  
Southampton, SO40 9RB, UK  
Telephone: 44 (0) 8708501241

#### **RECORD OF REVISIONS**

| <b>Revision</b> | <b>Revision Date</b> | <b>Description</b>   |
|-----------------|----------------------|--|
| A               | 10/04/05             | Initial Release  |
| B               | 2/1/06               | Update and Redraw  |
| C               | 5/16/06              | Added GSA 85A info, title change, redraw                   |
| D               | 6/8/06               | Added TSO/ETSO compliance table                            |
| E               | 3/5/07               | Revised drawings, changed "Servo Mount" to "Servo Gearbox" |
| F               | 6/22/07              | Modified temperature/humidity limits and added ICA         |

#### **DOCUMENT PAGINATION**

| <b>Section</b>    | <b>Page Range</b> |
|-------------------|-------------------|
| Table of Contents | i - viii          |
| Section 1         | 1-1 – 1-8         |
| Section 2         | 2-1 – 2-6         |
| Section 3         | 3-1 – 3-22        |
| Section 4         | 4-1 – 4-2         |
| Appendix A        | A-1 – A-56        |
| Appendix B        | B-1 – B-2         |

---

## **INFORMATION SUBJECT TO EXPORT CONTROL LAWS**

This document may contain information which is subject to the Export Administration Regulations ("EAR") issued by the United States Department of Commerce (15 CFR, Chapter VII, Subchapter C) and which may not be exported, released, or disclosed to foreign nationals inside or outside of the United States without first obtaining an export license. A violation of the EAR may be subject to a penalty of up to 10 years imprisonment and a fine of up to \$1,000,000 under Section 2410 of the Export Administration Act of 1979. Include this notice with any reproduced portion of this document.

### **WARNING**

This product, its packaging, and its components contain chemicals known to the State of California to cause cancer, birth defects, or reproductive harm. This Notice is being provided in accordance with California's Proposition 65. If you have any questions or would like additional information, please refer to our web site at [www.garmin.com/prop65](http://www.garmin.com/prop65).

### **NOTE**

Throughout this manual the GSM 85(A) Servo Mount is now referred to as a Servo Gearbox.

---

This page intentionally left blank

---

## TABLE OF CONTENTS

| PARAGRAPH  | PAGE |
|--|------|
| 1 GENERAL DESCRIPTION                                | 1-1  |
| 1.1 Introduction .....                               | 1-1  |
| 1.2 Equipment Description .....                      | 1-1  |
| 1.3 Interface Summary .....                          | 1-2  |
| 1.4 Technical Specifications .....                   | 1-3  |
| 1.5 Certification .....                              | 1-6  |
| 1.6 Limited Warranty .....                           | 1-8  |
| 2 INSTALLATION OVERVIEW                              | 2-1  |
| 2.1 Introduction .....                               | 2-1  |
| 2.2 Installation Materials .....                     | 2-1  |
| 2.3 Installation Considerations .....                | 2-3  |
| 3 INSTALLATION PROCEDURE                             | 3-1  |
| 3.1 Unpacking Unit .....                             | 3-1  |
| 3.2 Wiring Harness Installation .....                | 3-1  |
| 3.3 GSM 85(A) Slip-Clutch Setting Procedure .....    | 3-2  |
| 3.4 GSA/GSM Installation .....                       | 3-21 |
| 3.5 Post Installation Configuration & Checkout ..... | 3-22 |
| 3.6 Continued Airworthiness .....                    | 3-22 |
| 4 SYSTEM INTERCONNECTS                               | 4-1  |
| 4.1 GSA 8X Pin Function List .....                   | 4-1  |
| 4.2 Power .....                                      | 4-1  |
| 4.3 RS-485 Serial Data .....                         | 4-2  |
| 4.4 Servo Program Inputs .....                       | 4-2  |
| APPENDIX A OUTLINE AND INSTALLATION DRAWINGS         | A-1  |
| A.1 Introduction .....                               | A-1  |
| A.2 Drawing List .....                               | A-1  |
| APPENDIX B INTERCONNECT DIAGRAMS                     | B-1  |

## LIST OF FIGURES

| FIGURE   | PAGE |
|--|------|
| 1-1 GSA 81 Servo Actuator .....  | 1-1  |
| 1-2 GSM 85 Servo Gearbox .....   | 1-2  |
| 2-1 Slip-Clutch Adjustment Fixture (P/N T10-00110-01) .....  | 2-5  |
| 3-1 Sprocket Capstan Assembly Drawing.....   | 3-4  |
| 3-2 Castle Nut Detail Drawing .....  | 3-4  |
| 3-3 Slip-Clutch Adjustment Fixture (P/N T10-00110-01) .....  | 3-5  |
| 3-4 Unit Placement .....   | 3-6  |
| 3-5 Clamp Adjustment .....   | 3-6  |
| 3-6 Cable Placement (fixture capstan).....   | 3-7  |
| 3-7 Cable Placement (fixture capstan).....   | 3-7  |
| 3-8 Cable Placement (unit capstan).....  | 3-7  |
| 3-9 Cable End Placement (unit capstan).....  | 3-8  |
| 3-10 Inserting 3/32" cable in the unit capstan .....   | 3-9  |
| 3-11 Cable around unit capstan, showing end of cable near test fixture capstan bottom slot .....         | 3-9  |
| 3-12 Cable inserted in bottom slot of fixture capstan.....   | 3-10 |
| 3-13 Cable inserted in test fixture capstan top slot.....  | 3-10 |
| 3-14 Cable wrapped around test fixture capstan, remaining end installed in unit capstan bottom slot..... | 3-11 |
| 3-15 3/32" Cable with retainer clips at center of travel.....  | 3-11 |
| 3-16 Cable end inserted in bottom slot.....  | 3-12 |
| 3-17 Cable wrapped 2.5 times, going across to unit capstan lower slot.....                               | 3-12 |
| 3-18 Cable wrapped around idler middle slot .....  | 3-13 |
| 3-19 Cable wrapped around unit upper slot.....   | 3-13 |
| 3-20 Cable routed to fixture capstan.....  | 3-14 |
| 3-21 Cable wrapped and inserted in upper slot of fixture capstan .....                                   | 3-14 |
| 3-22 Slack taken up, capstan centered.....   | 3-15 |
| 3-23 Slack taken up, capstan centered (view from top).....   | 3-15 |
| 3-24 Sprocket capstan installed on fixture .....   | 3-16 |
| 3-25 Chain around unit sprocket .....  | 3-16 |
| 3-26 Chain engaged on both sprockets, supported by hand .....  | 3-17 |
| 3-27 Chain slack removed.....  | 3-17 |
| 3-28 Fixture Adjustment Knob.....  | 3-18 |
| 3-29 Fixture Adjustment Wingnuts.....  | 3-18 |
| 3-30 Torque Wrench Placement.....  | 3-19 |
| 3-31 Removing Swaged Ball from Retaining Clip.....   | 3-20 |
| 4-1 J801 Connector Layout .....  | 4-1  |
| A-1 GSA 80 Outline Drawing.....  | A-3  |
| A-2 GSA 81 (-00) Outline Drawing.....  | A-5  |
| A-3 GSA 81 (-10) Outline Drawing.....  | A-7  |
| A-4 GSM 85 Servo Gearbox For 1/16" Cable, 2 Bolt (Sheet 1 of 2).....                                     | A-9  |
| A-4 GSM 85 Servo Gearbox For 1/16" Cable, 2 Bolt (Sheet 2 of 2).....                                     | A-11 |
| A-5 GSM 85 Servo Gearbox For 1/16" Cable, 4 Bolt (Sheet 1 of 2).....                                     | A-13 |
| A-5 GSM 85 Servo Gearbox For 1/16" Cable, 4 Bolt (Sheet 2 of 2).....                                     | A-15 |
| A-6 GSM 85 Servo Gearbox For 3/32" Cable (Sheet 1 of 2).....   | A-17 |
| A-6 GSM 85 Servo Gearbox For 3/32" Cable (Sheet 2 of 2).....   | A-19 |
| A-7 GSM 85 Servo Gearbox, Continuous Travel (Sheet 1 of 2) .....   | A-21 |
| A-7 GSM 85 Servo Gearbox, Continuous Travel (Sheet 2 of 2) .....   | A-23 |

|      |  |      |
|------|--|------|
| A-8  | GSM 85 Servo Gearbox With Sprocket (Sheet 1 of 2)  | A-25 |
| A-8  | GSM 85 Servo Gearbox With Sprocket (Sheet 2 of 2)  | A-27 |
| A-9  | GSM 85 Universal Hub Servo Gearbox (Sheet 1 of 2)  | A-29 |
| A-9  | GSM 85 Universal Hub Servo Gearbox (Sheet 2 of 2)  | A-31 |
| A-10 | GSM 85A Servo Gearbox For 3/32" Cable (Sheet 1 of 2)   | A-33 |
| A-10 | GSM 85A Servo Gearbox For 3/32" Cable (Sheet 2 of 2)   | A-35 |
| A-11 | GSM 85A Servo Gearbox For 1/16" Cable (Sheet 1 of 2)   | A-37 |
| A-11 | GSM 85A Servo Gearbox For 1/16" Cable (Sheet 2 of 2)   | A-39 |
| A-12 | GSM 85A Servo Gearbox With Universal Hub (Sheet 1 of 3)  | A-41 |
| A-12 | GSM 85A Servo Gearbox With Universal Hub, Optional Sprocket (Sheet 2 of 3)                       | A-43 |
| A-12 | GSM 85A Servo Gearbox With Universal Hub, Generic Attachment (Sheet 3 of 3)                      | A-45 |
| A-13 | GSM 85A Servo Gearbox For 1/16" Cable, Continous Travel (Sheet 1 of 2)                           | A-47 |
| A-13 | GSM 85A Servo Gearbox For 1/16" Cable, Continous Travel (Sheet 1 of 2)                           | A-49 |
| A-14 | Cable Wrap Recommendations And Requirements, 1/16" Spiral Capstan GSM 85/GSM 85A                 | A-51 |
| A-15 | Cable Wrap Recommendations And Requirements For Continuous Travel Servo Gearboxes GSM 85/GSM 85A | A-53 |
| A-16 | Servo Motor And Gearbox Alignment  | A-55 |
| B-1  | GSA 8X Interconnect Diagram  | B-1  |

**LIST OF TABLES**

| TABLE | PAGE                                  |     |
|-------|---------------------------------------|-----|
| 1-1   | GSA 8X Servo Actuator                 | 1-3 |
| 1-2   | GSM 85(A) Servo Gearbox               | 1-4 |
| 1-3   | Operational Characteristics           | 1-4 |
| 1-4   | Torque Specifications                 | 1-4 |
| 1-5   | Torque Tolerance                      | 1-5 |
| 1-6   | Electrical Specifications             | 1-5 |
| 1-7   | TSO Deviations                        | 1-6 |
| 1-8   | TSO/ETSO Deviations                   | 1-7 |
| 2-1   | GSA 8X Part Numbers                   | 2-1 |
| 2-2   | GSM 85(A) Part Numbers                | 2-2 |
| 2-3   | GSA 8X Accessories                    | 2-3 |
| 2-4   | GSM 85(A) Accessories                 | 2-3 |
| 3-1   | Recommended Crimp Tools               | 3-1 |
| 4-1   | J801 Connector I/O                    | 4-1 |
| 4-2   | J801 Connector Power Pins I/O         | 4-1 |
| 4-3   | RS-485 Pins                           | 4-2 |
| 4-4   | Servo Program Inputs                  | 4-2 |
| 4-5   | Servo Function Logic Table            | 4-2 |
| A-1   | Outline And Installation Drawing List | A-1 |

**GSA 80 HARDWARE MOD LEVEL HISTORY**

| <b>Applicable Unit Part Number</b> | <b>MOD LEVEL</b> | <b>SERVICE BULLETIN NUMBER</b> | <b>SERVICE BULLETIN DATE</b> | <b>PURPOSE OF MODIFICATION</b>   |
|------------------------------------|------------------|--------------------------------|------------------------------|--|
| 011-00877-00*                      | 1                | 0704                           | 3/1/07                       | This modification addresses a potential GSA 80 condition that could allow the control magnet to detach from the carrier. |
|                                    |                  |                                |                              |  |

\*Only serial numbers 66300000 through 66301026 are affected.

**GSA 81 HARDWARE MOD LEVEL HISTORY**

| <b>Applicable Unit Part Number</b> | <b>MOD LEVEL</b> | <b>SERVICE BULLETIN NUMBER</b> | <b>SERVICE BULLETIN DATE</b> | <b>PURPOSE OF MODIFICATION</b> |
|------------------------------------|------------------|--------------------------------|------------------------------|--------------------------------|
|                                    |                  |                                |                              |                                |
|                                    |                  |                                |                              |                                |

**GSM 85 HARDWARE MOD LEVEL HISTORY**

| <b>Applicable Unit Part Number</b>   | <b>MOD LEVEL</b> | <b>SERVICE BULLETIN NUMBER</b> | <b>SERVICE BULLETIN DATE</b> | <b>PURPOSE OF MODIFICATION</b>   |
|--|------------------|--------------------------------|------------------------------|--|
| 011-00894-00<br>011-00894-10   | 1                | N/A                            | N/A                          | This modification decreases the outer diameter of the capstan.   |
|  | 2                | N/A                            | N/A                          | This modification changes the slip clutch material and spring washers.   |
|  | 3                |                                |                              |  |
| 011-00894-02<br>011-00894-04<br>011-00894-06<br>011-00894-07<br>011-00894-08<br>011-00894-09<br>011-00894-11<br>011-00894-14 | 1                | 0713                           | 5/18/07                      | All GSM 85 servo gearboxes must be inspected for the presence of FOD (Foreign Object Debris) that may be inside the housing. |



---

**GSM 85A HARDWARE MOD LEVEL HISTORY**

| <b>Applicable<br/>Unit Part<br/>Number</b>   | <b>MOD<br/>LEVEL</b> | <b>SERVICE<br/>BULLETIN<br/>NUMBER</b> | <b>SERVICE<br/>BULLETIN<br/>DATE</b> | <b>PURPOSE OF MODIFICATION</b>   |
|--|----------------------|--|--------------------------------------|--|
| 011-01436-A0<br>011-01436-A2<br>011-01436-A3 | 1                    | 0623                                   | 11/2/06                              | This modification addresses a potential GSM 85A condition that could allow the capstan cover to interfere with the cable guard pins. |

---

This page intentionally left blank

---

# 1 GENERAL DESCRIPTION

## 1.1 Introduction

This manual presents mechanical and electrical installation requirements for installing the GSA 80 or GSA 81 servo actuator (referred to in this document as “GSA 8X”) and the GSM 85 or GSM 85A servo gearbox (referred to in this document as “GSM 85(A)”) as part of the GFC 700 Automatic Flight Control System, a sub-system of the G1000 Integrated Cockpit System. The GFC 700 system can be integrated into a variety of airframes under an appropriate Type Certification (TC) or Supplemental Type Certification (STC). Individual airframe installations may vary; use only approved (type or supplemental type) data for specific installation instructions in a particular aircraft.

## 1.2 Equipment Description

### 1.2.1 GSA 80 and GSA 81 Servo Actuator

The GSA 8X servo actuator is an electromechanical unit that provides automatic control of a single flight axis (pitch, roll, or yaw), or their associated trims. The GSA 8X contains a motor-control and monitor circuit board, as well as a solenoid and a brushless DC motor, all enclosed in an extruded aluminum housing.

The GSA 8X receives serial RS-485 data packets from two GIA Integrated Avionics units, which contain data from the flight director, the GRS 77 AHRS, and the GDC 74 Air Data Computer. The motor-control board processes this incoming data and drives the brushless motor as necessary to obtain the desired aircraft response. The monitor board independently monitors the servo speed, monitors the output torque, and controls the engagement of the drive-clutch solenoid.

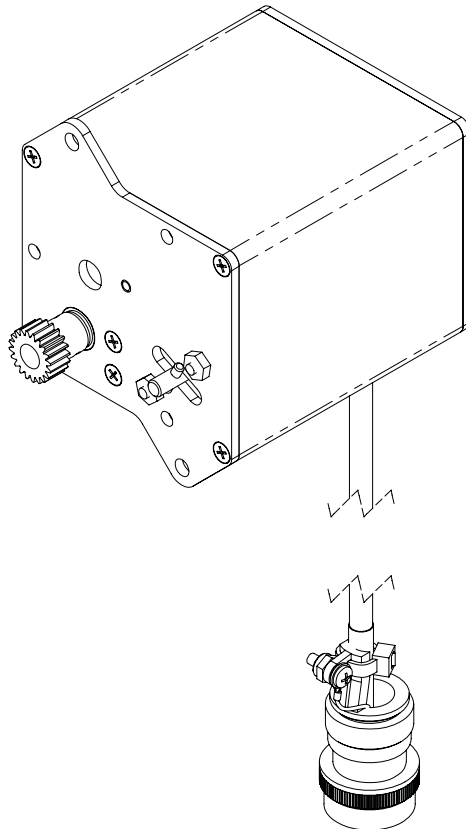

**Figure 1-1. GSA 81 Servo Actuator**

---

## 1.2.2 GSM 85 and GSM 85A Servo Gearbox

The GSM 85(A) servo gearbox is mounted to the aircraft structure, via a custom mounting bracket, and is responsible for transferring the output torque of the GSA 8X servo actuator to the mechanical flight-control surface linkage. The GSM 85(A) houses its internal components within an extruded aluminum housing, like the GSA 8X. There are multiple variations of the GSM 85(A), all designed to accommodate various flight-control system interfaces and torque requirements. The slip-clutch settings, type of output capstan, and the available part numbers are listed in Tables 1-4 and 2-2.

The GSM 85A is similar to the GSM 85, but has additional components to allow use in more harsh environments. The GSM 85A has been tested in the same environmental conditions as the GSM 85, and additionally tested for fluid susceptibility, sand and dust, salt spray, and more rigorous icing requirements. See the Environmental Qualification Form (Garmin part number 005-00231-01 for GSM 85 and 005-00231-06 for GSM 85A) for a list of specific conditions tested.

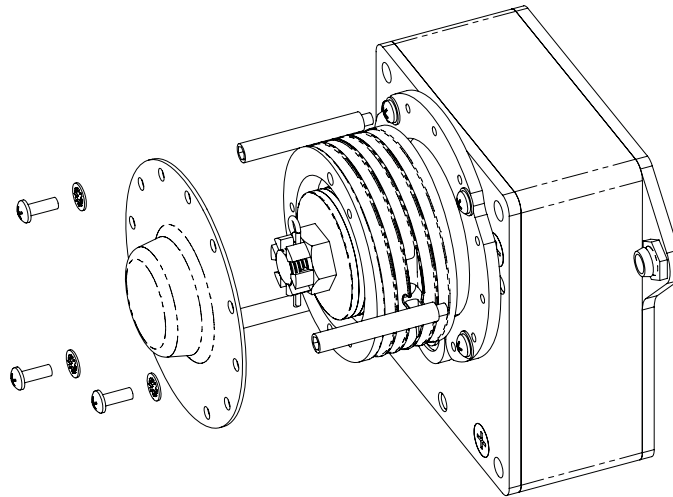

**Figure 1-2. GSM 85 Servo Gearbox**

## 1.2.3 Operational Description

The GSA 8X servo actuator, when mated with the GSM 85(A) servo gearbox, drives a single flight-control axis of the airplane, or its associated trim. Once installed into the aircraft, the GSA 8X servo actuator may be easily removed for maintenance, without removing or de-rigging the GSM 85(A) servo gearbox. Note that while the GSA 8X is removed, it is recommended to use the Servo Gearbox Protective Cover (P/N 145-00807-00) to cover the opening of the GSM 85(A). The protective cover is included with the GSM 85(A) unit, and is designed to prevent foreign objects from falling into the GSM 85(A).

The engagement of the drive clutch in the GSM 85(A) is controlled by a solenoid in the GSA 8X.

A slip-clutch allows the capstan to rotate independently of the GSA 8X whenever sufficient force is applied to the capstan (see Section 1.4.4). This allows the pilot to override the operation of the GSA 8X in the event of a malfunction by applying sufficient force to overcome the slip-clutch setting.

## 1.3 Interface Summary

The GSA 8X interfaces with two GIA Integrated Avionics units through serial communication, on separate RS-485 ports.

---

## 1.4 Technical Specifications

### 1.4.1 Environmental Qualification Forms

It is the responsibility of the installing agency to obtain the latest revision of the GSA 80, GSA 81, GSM 85, and GSM 85A Environmental Qualification Forms. These forms are available directly from Garmin under the following part numbers:

GSA 80 Servo Actuator EQF: 005-00188-02

GSA 81 Servo Actuator EQF: 005-00203-02

GSM 85 Servo Gearbox EQF: 005-00231-01

GSM 85A Servo Gearbox EQF: 005-00231-06

To obtain a copy of these forms, see the dealer/OEM portion of the Garmin web site ([www.garmin.com](http://www.garmin.com)).

### 1.4.2 Physical Characteristics

See Tables 1-1 and 1-2 for unit dimension and weight specifications.

|             |
|-------------|
| <b>NOTE</b> |
|-------------|

The weight of the applicable parts in the Cableguard Ring Kit (011-01336-XX) or the Chainguard Ring Kit (011-01375-XX) is included in the weight of the GSM 85 Servo Gearbox units listed in Table 1-2.

**Table 1-1. GSA 8X Servo Actuator**

| <b>Characteristics</b>        | <b>Specifications</b>               |
|-------------------------------|-------------------------------------|
| Width                         | See Appendix A for unit dimensions. |
| Height                        |                                     |
| Length                        |                                     |
| GSA 80 Unit Weight            | 3.11 lbs. (1.41 kg)                 |
| GSA 81 Unit Weight            | 2.18 lbs. (0.99 kg)                 |
| GSA 80 & Connector Kit Weight | 3.20 lbs. (1.45 kg)                 |
| GSA 81 & Connector Kit Weight | 2.27 lbs. (1.03 kg)                 |

**Table 1-2. GSM 85(A) Servo Gearbox**

| Characteristics                                | Specifications  |
|--|---|
| Width  | See Appendix A for unit dimensions.                     |
| Height   |   |
| Depth  |   |
| 011-00894-00 weight                            | 1.38 lbs. (0.63 kg)                                     |
| 011-00894-02 weight                            | 1.50 lbs. (0.68 kg)                                     |
| 011-00894-04 weight                            | 1.61 lbs. (0.73 kg)                                     |
| 011-00894-06 weight                            | 1.42 lbs. (0.64 kg)                                     |
| 011-00894-07 weight                            | 1.38 lbs. (0.63 kg)                                     |
| 011-00894-08 weight                            | 1.40 lbs. (0.64 kg)                                     |
| 011-00894-09 weight                            | 1.38 lbs. (0.63 kg)                                     |
| 011-00894-10 weight                            | 1.40 lbs. (0.64 kg)                                     |
| 011-00894-11 weight                            | 1.44 lbs. (0.65 kg)                                     |
| 011-00894-14 weight                            | 1.63 lbs. (0.74 kg)                                     |
| 011-01436-00 weight                            | 1.55 lbs. (0.70 kg)                                     |
| 011-01436-01 weight                            | 1.55 lbs. (0.70 kg)                                     |
| 011-01436-02 weight                            | 1.51 lbs. (0.68 kg)                                     |
| 011-01436-03 weight                            | 1.51 lbs. (0.68 kg)                                     |
| 011-01436-04 weight                            | 1.46 lbs. (0.66 kg)                                     |
| 011-01436-05 weight                            | 1.46 lbs. (0.66 kg)                                     |
| 011-01436-06 weight                            | 1.46 lbs. (0.66 kg)                                     |
| 011-01436-07 weight                            | 1.61 lbs. (0.73 kg)                                     |
| 011-01436-08 weight                            | 1.61 lbs. (0.73 kg)                                     |
| 011-01028-00, -01, -02, -03 Install kit weight | 0.11 lbs. (0.05 kg)                                     |
| 011-01028-04 Standoff kit weight               | 0.07 lbs. (0.03 kg)                                     |
| 011-01028-05, -06 Cover kit weight             | 0.03 lbs. (0.01 kg)                                     |
| 011-01028-07 Cover kit weight                  | 0.10 lbs. (0.05 kg)                                     |
| 011-01028-08 Cover kit weight                  | 0.07 lbs. (0.03 kg)                                     |
| 011-01336-XX Cableguard Ring Kit weight        | Applicable weight is included in weight of above units. |
| 011-01375-XX Chainguard Ring Kit weight        | Applicable weight is included in weight of above units. |

### 1.4.3 General Specifications

See Table 1-3 for operational characteristics. For more details see the GSA80, GSA 81, GSM 85, or GSM 85A Environmental Qualification Forms (Section 1.4.1).

**Table 1-3. Operational Characteristics**

| Characteristics                                      | Specifications          |
|--|-------------------------|
| Total Output Torque<br>(GSA 81 & GSM 85(A) combined) | Up to 60 in-lbs         |
| Total Output Torque (GSA 80 & GSM 85(A) combined)    | Up to 200 in-lbs        |
| Operating Temperature Range                          | -55°C to +70°C.         |
| Altitude Range                                       | -15,000 ft to 55,000 ft |

### 1.4.4 GSM 85(A) Slip-Clutch Specifications

The GSM 85(A) servo gearbox is available in three torque ranges (low, medium, and high), for each of the available mechanical interface configurations (spiral, continuous, and sprocket, etc.), as defined by Table 1-4. Refer to Table 1-5 for clutch tolerances.

**Table 1-4. Torque Specifications**

| <b>Slip-Clutch</b> | <b>Nominal Torque Settings Allowable</b> |
|--------------------|--|
| High Torque        | 90-160 in-lbs                            |
| Medium Torque      | 40-90 in-lbs                             |
| Low Torque         | 20-50 in-lbs                             |

**Table 1-5. Torque Tolerance**

| <b>Nominal Setting (in-lbs)</b> | <b>Initial Setting or check using clutch setting stand (in-lbs)*</b> | <b>Clutch check using GDU and load cell in GSA 8x*</b> | <b>Expected performance in airplane</b> |
|---------------------------------|--|--|---|
| 20-29                           | +/- 4  | +/- 20%  | +/- 30%                                 |
| 30-39                           | +/- 5  | +/- 20%  | +/- 30%                                 |
| 40-49                           | +/- 6  | +/- 20%  | +/- 30%                                 |
| 50-59                           | +/- 7  | +/- 20%  | +/- 30%                                 |
| 60-69                           | +/- 8  | +/- 20%  | +/- 30%                                 |
| 70-79                           | +/- 9  | +/- 20%  | +/- 30%                                 |
| 80-89                           | +/- 10   | +/- 20%  | +/- 30%                                 |
| 90-99                           | +/- 10   | +/- 20%  | +/- 30%                                 |
| above 100                       | +/- 10%  | +/- 20%  | +/- 30%                                 |

\* Percentages may be rounded to the nearest whole number if desired. Values should not be specified more precisely than 0.1 in-lbs increments.

### 1.4.5 Power Requirements

See Table 1-6 for electrical power specifications.

**Table 1-6. Electrical Specifications**

| <b>Characteristics</b> | <b>Specifications</b>  |
|------------------------|--|
| Input Voltage Range    | 28 Vdc (80 V Surge) Note that some degradation of torque/speed capability will occur when operated below 27.5 Vdc. |
| Power Consumption      | 45W maximum, at peak torque output   |

## 1.5 Certification

The conditions and tests required for TSO approval of this article are minimum performance standards. It is the responsibility of those installing this article either on or within a specific type or class of aircraft to determine that the aircraft installation conditions are within the TSO standards. TSO articles must have separate approval for installation in an aircraft. The article may be installed only if performed under 14 CFR Part 43 or the applicable airworthiness requirements. At the time of publication, installations of this TSO approved article are only approved when installed in an aircraft as part of a Garmin G1000 system.

### 1.5.1 TSO/ETSO Compliance

Table 1-7. TSO/ETSO Compliance

| LRU     | LRU P/N                        | TSO / ETSO          | Applicable LRU SW Part Numbers  |
|---------|--------------------------------|---------------------|---|
| GSA 80  | 010-00302-( )<br>011-00877-( ) | TSO-C9c<br>ETSO-C9c | All<br>006-B0398-( )<br>except<br>006-B0398-00<br>through<br>006-B0398-14 |
| GSA 81  | 010-00303-( )<br>011-00878-( ) | TSO-C9c<br>ETSO-C9c | All<br>006-B0398-( )<br>except<br>006-B0398-00<br>through<br>006-B0398-10 |
| GSM 85  | 010-00304-( )<br>011-00894-( ) | TSO-C9c<br>ETSO-C9c | Not Applicable  |
| GSM 85A | 010-00556-( )<br>011-01436-( ) | TSO-C9c             | Not Applicable  |



## 1.5.2 TSO/ETSO Deviations

Table 1-8. TSO/ETSO Deviations

| TSO/ETSO | Deviation  |
|----------|--|
| TSO-C9c  | 1. Garmin was granted a deviation from TSO-C9c to use SAE AS-402B instead of AS-402A.  |
|          | 2. Garmin was granted a deviation from AS-402B paragraph 4.4.1 to limit autopilot engagement to attitudes considered safe for the certified aircraft.  |
|          | 3. Garmin was granted a deviation from TSO-C9c to use DO-160D instead of specified environmental tests (applies to GSA 81 and GSM 85).   |
|          | 4. Garmin was granted a deviation from TSO-C9c subpart A (c), which requires marking the weight of the unit on the unit. Garmin will provide this information in the installation manual in lieu of marking on the serial tag. |
|          | 5. Garmin was granted a deviation from AS-402B paragraph 4.3.2 to not provide servo effort indications when the automatic pilot is not engaged.  |
|          | 6. Garmin was granted a deviation from TSO-C9c to use DO-160E instead of specified environmental tests (applies to GSA 80 and GSM 85A).  |
| ETSO-C9c | 1. Garmin was granted a deviation from ETSO-C9c to use SAE AS-402B instead of AS-402A.   |
|          | 2. Garmin was granted a deviation from ETSO-C9c to use DO-160E instead of the specified environmental tests.   |

---

## 1.6 Limited Warranty

This Garmin product is warranted to be free from defects in materials or workmanship for two years from the date of purchase. Within this period, Garmin will at its sole option, repair or replace any components that fail in normal use. Such repairs or replacement will be made at no charge to the customer for parts or labor, provided that the customer shall be responsible for any transportation cost. This warranty does not cover failures due to abuse, misuse, accident or unauthorized alteration or repairs.

THE WARRANTIES AND REMEDIES CONTAINED HEREIN ARE EXCLUSIVE AND IN LIEU OF ALL OTHER WARRANTIES EXPRESS OR IMPLIED OR STATUTORY, INCLUDING ANY LIABILITY ARISING UNDER ANY WARRANTY OF MERCHANTABILITY OR FITNESS FOR A PARTICULAR PURPOSE, STATUTORY OR OTHERWISE. THIS WARRANTY GIVES YOU SPECIFIC LEGAL RIGHTS, WHICH MAY VARY FROM STATE TO STATE.

IN NO EVENT SHALL GARMIN BE LIABLE FOR ANY INCIDENTAL, SPECIAL, INDIRECT OR CONSEQUENTIAL DAMAGES, WHETHER RESULTING FROM THE USE, MISUSE, OR INABILITY TO USE THIS PRODUCT OR FROM DEFECTS IN THE PRODUCT. Some states do not allow the exclusion of incidental or consequential damages, so the above limitations may not apply to you.

Garmin retains the exclusive right to repair or replace the unit or software or offer a full refund of the purchase price at its sole discretion. SUCH REMEDY SHALL BE YOUR SOLE AND EXCLUSIVE REMEDY FOR ANY BREACH OF WARRANTY.

To obtain warranty service, contact your local Garmin Authorized Service Center. For assistance in locating a Service Center near you, call Garmin Customer Service at one of the numbers shown below.

Products sold through online auctions are not eligible for rebates or other special offers from Garmin. Online auction confirmations are not accepted for warranty verification. To obtain warranty service, an original or copy of the sales receipt from the original retailer is required. Garmin will not replace missing components from any package purchased through an online auction.

Garmin International, Inc.  
1200 E. 151st Street  
Olathe, KS 66062, U.S.A.  
Phone: 800/800.1020  
FAX: 913/397.0836

Garmin (Europe) Ltd.  
Liberty House  
Bulls Copse Road  
Hounslow Business Park  
Southampton, SO40 9RB, UK  
Telephone: 44 (0) 8708501241

---

## 2 INSTALLATION OVERVIEW

### 2.1 Introduction

This section provides hardware equipment information for installing the GSA 8X Servo Actuator, GSM 85(A) Servo Gearbox, and related hardware. Installation of the Servo Actuator and Servo Gearbox should follow the aircraft Type Certification (TC) or Supplemental Type Certification (STC) requirements. Cabling is fabricated by the installing agency to fit each particular aircraft.

### 2.2 Installation Materials

Tables 2-1 and 2-2 list the available unit part numbers.

**Table 2-1. GSA 8X Part Numbers**

| <b>Item</b>                       | <b>Catalog P/N</b> |
|-----------------------------------|--------------------|
| GSA 80, Unit Only, (011-00877-00) | 010-00302-00       |
| GSA 81, Unit Only, (011-00878-00) | 010-00303-00       |
| GSA 81, Unit Only, (011-00878-10) | 010-00303-10       |

**Table 2-2. GSM 85(A) Part Numbers**

| Item  |  | Catalog P/N  |
|---|--|--------------|
| GSM 85, Unit Only, (011-00894-XX) is available in the following configurations*:  |  |              |
| 011-00894-00  | Spiral Capstan, Low Torque                 | 010-00304-00 |
| 011-00894-02  | Continuous Travel Capstan, Low Torque      | 010-00304-02 |
| 011-00894-04  | Sprocket Capstan, Low Torque               | 010-00304-04 |
| 011-00894-06  | Spiral Capstan, Low Torque, Ball Bearing   | 010-00304-06 |
| 011-00894-07  | Spiral Capstan, Low Torque                 | 010-00304-07 |
| 011-00894-08  | Spiral Capstan, Medium Torque              | 010-00304-08 |
| 011-00894-09  | Universal Hub, Medium torque               | 010-00304-09 |
| 011-00894-10  | Spiral Capstan, Medium Torque              | 010-00304-10 |
| 011-00894-11  | Spiral Capstan, Medium Torque, 3/32" Cable | 010-00304-11 |
| 011-00894-14  | Sprocket Capstan, Medium Torque            | 010-00304-14 |
| GSM 85A, Unit Only, (011-01436-XX) is available in the following configurations*: |  |              |
| 011-01436-00  | 3/32" Spiral Capstan, High Torque          | 010-00556-00 |
| 011-01436-01  | 3/32" Spiral Capstan, Medium Torque        | 010-00556-01 |
| 011-01436-02  | 1/16" Spiral Capstan, Medium Torque        | 010-00556-02 |
| 011-01436-03  | 1/16" Spiral Capstan, Low Torque           | 010-00556-03 |
| 011-01436-04  | Universal Hub, High Torque                 | 010-00556-04 |
| 011-01436-05  | Universal Hub, Medium Torque               | 010-00556-05 |
| 011-01436-06  | Universal Hub, Low Torque                  | 010-00556-06 |
| 011-01436-07  | Continuous Travel Capstan, Medium Torque   | 010-00556-07 |
| 011-01436-08  | Continuous Travel Capstan, Low Torque      | 010-00556-08 |

\*New versions may be created that will not necessarily be added to this document.

## 2.2.1 Equipment Available

Tables 2-3 and 2-4 list the available accessories for the GSA and GSM products. Each of the following accessories is provided separately from the GSA 8X and GSM 85(A) units and is required to install the unit.

**Table 2-3. GSA 8X Accessories**

| Item                 | Garmin P/N   |
|----------------------|--------------|
| GSA 8X Connector Kit | 011-01027-00 |

**Table 2-4. GSM 85(A) Accessories**

| Item   | Garmin P/N    |
|--|---------------|
| GSM 85 Mounting Hardware for Spiral Capstan            | 011-01028-00  |
| GSM 85 Mounting Hardware for Continuous Travel Capstan | 011-01028-01  |
| GSM 85 Mounting Hardware for Sprocket Capstan          | 011-01028-02  |
| GSM 85 Mounting Hardware for Universal Hub             | 011-01028-03  |
| GSM 85(A) Standoff kit                                 | 011-01028-04  |
| GSM 85A Standard Capstan Cover kit                     | 011-01028-05  |
| GSM 85A Universal Hub Cover kit                        | 011-01028-06  |
| GSM 85A Universal Hub Sprocket and Cover Kit           | 011-01028-07  |
| GSM 85A Continuous Travel Standoff Kit                 | 011-01028-08  |
| GSM 85(A) Cableguard Ring Kit                          | 011-01336-XX* |
| GSM 85(A) Chainguard Ring Kit                          | 011-01375-XX* |

\*Note that Aircraft-specific installation documentation will specify the proper dash number cableguard or chainguard ring kit. New installations may require a new kit.

## 2.3 Installation Considerations

The GSA 8X servo actuator interfaces directly with the GIA Integrated Avionics Units. Fabrication of a wiring harness is required. Sound mechanical and electrical methods and practices are required for installation of the servo and servo gearbox.

### 2.3.1 Cabling & Wiring

The contacts supplied in the GSA 8X connector kit will accept wire from AWG #24 to AWG #20. AWG #24 may be used for all connections, except for AIRCRAFT\_POWER, AP\_DISCONNECT, and POWER GROUND, which must be AWG #22 or larger.

In cases where installations have more than one unit sharing a common circuit breaker, sizing and wire gauge is based on aircraft circuit breaker layout, length of wiring, current draw of units, and internal unit protection characteristics. Wire the circuit breakers as specified on the aircraft manufacturer approved drawings.

Make sure that the wire routing does not allow the wire to come in contact with sources of heat, or RF/EMI interference. Check that there is ample space for the cabling and mating connectors. Avoid sharp bends in cabling, bends in cabling must measure greater than a 1" bend radius, measured at the outside of the cable. Avoid routing cabling and wiring near aircraft control cables.

---

## 2.3.2 Mounting Requirements

The GSM 85(A) is to be mounted to a structurally sound, rigid bracket. This bracket should be firmly attached to the aircraft structure. Servo gearbox bracket design varies between installations. The installer should follow FAA guidance in the selection of bracket location, fabrication, and installation. The bracket must have the correct cut-out for the servo gearbox being used. Consult Appendix A for outline drawings showing these cut-outs.

The servo gearbox is to be fastened to the bracket using AN3-3A bolts with AN960-10 washers. Bolts should thread into the front plate of the servo gearbox at least 0.25", at most 0.75", and torqued to 45 in-lbs (+/- 5 in lbs). The GSA 8X servo actuator is fastened to the GSM 85(A) servo gearbox using AN3-4A bolts torqued to 45 in-lbs (+/- 5 in lbs) with AN960-10L washers (or using AN3-5A bolts with two AN960-10 washers per bolt). Mounting hardware is to be provided by the installing agency.

For all DO-160 categories in the GSM 85(A) Environmental Qualification Form (EQF, 005-00231-01 for GSM 85 and 005-00231-06 for GSM 85A) to apply, the appropriate servo gearbox capstan cover (included in the mounting hardware kit 011-01028-XX) must be installed as shown in Appendix A Outline and Installation Drawings, of this document. The GSM 85(A) must have the appropriate servo gearbox cover in place to ensure meeting the qualifications for "Waterproofness", "Sand and Dust", "Salt Spray", "Icing", and "Fluids" listed in the Environmental Qualification Form.

For installations of the Universal Hub Medium Torque GSM 85 (011-00894-09), limit the weight of aircraft interface parts attached to the hub to 0.29 lbs, to ensure compliance with the vibration specification. This includes the weight of parts solidly connected to the hub including screws and any hub cover spacers (115-00823-00) needed. However do not include the weight of the hub cover (117-00192-00) or any attachment part not solidly mounted on the hub such as a chain or articulating rod arm.

Ensure cable payoff angles (angle between the cable and capstan groove where it exits) do not exceed 3 degrees. The groove on the 1/16" cable spiral-wrap capstan is 1.3 degrees from parallel with the face of the servo gear box at any cable exit point. The groove on the 3/32" cable spiral-wrap capstan is 1.6 degrees from parallel with the face of the servo gear box at any cable exit point.

### 2.3.3 Slip-Clutch Adjustment

In order to install the GSM 85(A), the slip-clutch must first be set to the prescribed slip point. This is accomplished by using the test fixture shown in Figure 2-1. A motor attached below the fixture turns the capstan in both clockwise and counter-clockwise directions. The capstan is connected using a chain or cable to an idler pulley. A torque wrench attaches to the pulley. The wrench's travel is limited by means of a supporting bracket, which prevents the capstan from being able to rotate freely. Any torque that is applied to the capstan is transferred through the idler pulley and is shown in in-lbs on the torque wrench. The technician can set the slip-clutch to the proper value by setting the clutch adjustment nut while observing the torque wrench. See Section 3.3 for the slip-clutch setting procedure.

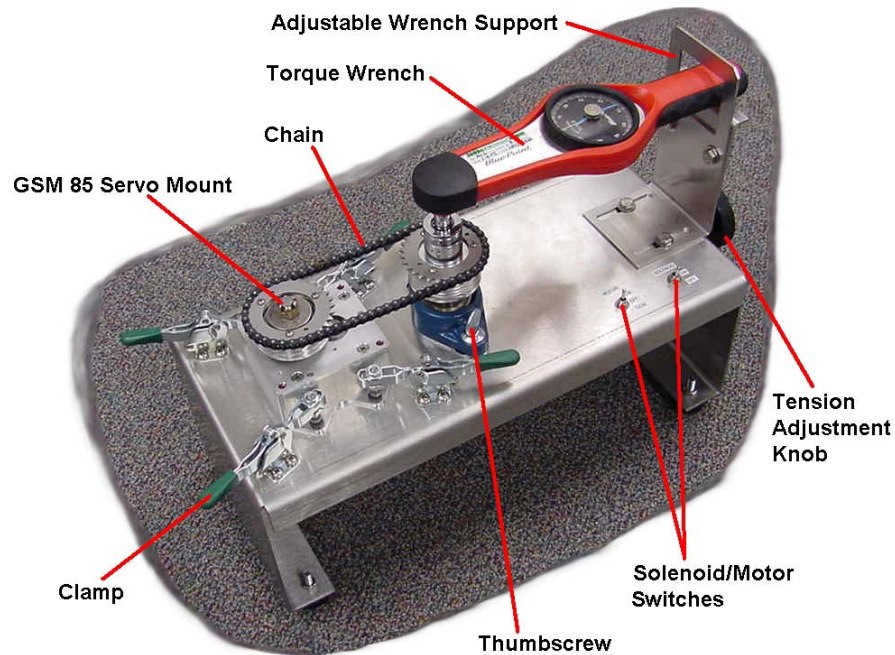

Figure 2-1. Slip-Clutch Adjustment Fixture (P/N T10-00110-01)

---

This page intentionally left blank



---

## 3 INSTALLATION PROCEDURE

### 3.1 Unpacking Unit

Carefully unpack the equipment and make a visual inspection of the unit for evidence of damage incurred during shipment. If the unit is damaged, notify the carrier and file a claim. To justify a claim, save the original shipping container and all packing materials. Do not return the unit to Garmin until the carrier has authorized the claim.

Retain the original shipping containers for storage. If the original containers are not available, a separate cardboard container should be prepared that is large enough to accommodate sufficient packing material to prevent movement.

### 3.2 Wiring Harness Installation

Allow adequate space for installation of cables and connectors. The installer shall supply and fabricate all of the cables. All wiring must be performed in accordance with FAA acceptable methods and procedures. See section 2.3.1 for additional wiring specifications.

All electrical connections are made through a single 19-pin circular connector. Section 4 defines the electrical characteristics of all input and output signals. Required connectors and associated hardware are supplied with the connector kit.

See Appendix B for examples of interconnect wiring diagrams. Construct the actual harnesses in accordance with approved interconnect drawings, using a crimp tool listed in Table 3-1.

**Table 3-1. Recommended Crimp Tools**

| Manufacturer | Hand Crimping Tool | Turret Head | Insertion / Extraction Tool |
|--------------|--------------------|-------------|-----------------------------|
| Military P/N | M22520/1-01        | 22520/1-02  | Supplied w/ connector       |
| Daniels      | AF8                | H1A         | Supplied w/ connector       |

**NOTE**

Non-Garmin part numbers shown are not maintained by Garmin and consequently are subject to change without notice.

---

## 3.3 GSM 85(A) Slip-Clutch Setting Procedure

### 3.3.1 Introduction

This procedure gives the steps for setting the GSM 85(A) slip-clutch break-away torque values. This procedure requires the use of the Garmin Slip-Clutch Fixture, P/N T10-00110-01, described in Section 2.3.3. This procedure may be performed using either a sprocket or pulley type servo gearbox, equipment for both methods is provided with the Garmin Slip-Clutch Fixture. The GSM 85(A) Universal Hub (P/N 011-00894-09) unit uses a sprocket (P/N 380-00015-20) provided with the Garmin Slip-Clutch Fixture to complete this procedure.

#### NOTE

The installer must only use aircraft-specific slip-clutch adjustment values during this procedure. This is a sample procedure provided to give an overview of the clutch setting method recommended by Garmin. Always refer to aircraft-specific procedures that are approved by the aircraft manufacturer or by Garmin.

#### NOTE

Prior to performing the slip-clutch procedure, remove and discard the warning tag located on the servo gearbox that indicates that the clutch has not been set.

### 3.3.2 Precautions

The following precautions must be observed when assembling, testing, or replacing the Garmin Slip-Clutch Fixture.

#### 3.3.2.1 Mechanical Hazards

The slip-clutch fixture contains mechanical components that represent a potential hazard to service personnel. Keep fingers, hair, and clothing free of the mechanism to prevent injury or entrapment.

#### 3.3.2.2 Electrical Hazards

The slip-clutch fixture contains electrical circuitry. Always follow safe and accepted electrical service practices when operating this equipment.

#### 3.3.2.3 Torque Relief

To avoid damage to the torque wrench, always relieve the cable (or chain) tension before turning off the solenoid. Failure to do so may subject the torque wrench to potentially damaging large shock loads.

Relieve the cable (or chain) tension as follows:

- 1) Turn off motor, leaving solenoid on.
- 2) Turn motor on in opposite direction (of previous operation). Turn motor off after approx. ½ second, or when tension is relieved in cable (or chain). The tension is relieved when the wrench becomes loose in its support. Also, the torque wrench reading should be zero or close to zero.
- 3) Turn off solenoid once tension is relieved.

### 3.3.3 Environmental Conditions

It is recommended that clutches are set in room temperature conditions. 50°F to 120°F will yield the best results.

---

### 3.3.4 Required Equipment for Cable and Pulley Type Servo Gearbox

The following will be required to use the Garmin Slip-Clutch Fixture:

- 1) Garmin Slip-Clutch Fixture (P/N T10-00110-01)
- 2) Garmin cable (P/N 233-20001-02, 233-20002-00, or two 233-20003-00) included with fixture
- 3) Torque wrench\* capable of at least maximum setting desired for slip clutch
- 4) 13/16" socket to attach to torque wrench
- 5) 9/16" wrench for setting unit slip torque
- 6) Garmin GSM 85(A) Servo Gearbox
- 7) 2 Amp, 24 V, DC Power Supply.

\* Some torque wrenches only work properly when using a specific grip location, holding the torque wrench in another location may give false readings. These types of torque wrenches may NOT be used with this slip-clutch fixture. Recommended wrenches are the Snap-On Blue Point TE6FUE (up to 75 in-lbs) or TE25FUE (up to 200 in-lbs).

The following may be required to make adjustments to the Garmin Slip-Clutch Fixture:

- 1) 3/8" sockets or wrenches
- 2) 7/16" sockets or wrenches
- 3) #2 Phillips screwdriver

### 3.3.5 Required Equipment for Chain and Sprocket Type Servo Gearbox (also for Universal Hub type)

The following will be required to use the Garmin Slip-Clutch Fixture:

- 1) Garmin Slip-Clutch Fixture (P/N T10-00110-01)
- 2) Garmin Chain (P/N 233-30001-01) included with fixture
- 3) Garmin Sprocket (P/N 380-00015-00) included with fixture
- 4) Garmin Sprocket (P/N 380-00015-20) included with fixture (required for adjustment of GSM 85(A) Universal Hub unit only)
- 5) Garmin Sprocket Alignment Pins, 2 ea. (P/N 233-00071-03) included with fixture
- 6) Garmin Sprocket Mounting Screws, 3 ea. (P/N 211-60234-09) included with fixture
- 7) 8-32 type screws, 6 ea. to attach Garmin Sprocket (P/N 380-00015-20) required for adjustment of GSM 85(A) Universal Hub unit only
- 8) Torque wrench\* capable of at least maximum setting desired for slip clutch
- 9) 13/16" socket to attach to torque wrench
- 10) 9/16" wrench for setting unit slip torque
- 11) #2 Phillips screwdriver for installing capstan sprocket
- 12) Garmin GSM 85(A) Servo
- 13) 2 Amp, 24 V, DC Power Supply

\* Some torque wrenches only work properly when using a specific grip location, holding the torque wrench in another location may give false readings. These types of torque wrenches may NOT be used with this slip-clutch fixture. Recommended wrenches are the Snap-On Blue Point TE6FUE (up to 75 in-lbs) or TE25FUE (up to 200 in-lbs).

The following may be required to make adjustments to the Garmin Slip-Clutch Fixture:

- 1) 3/8" sockets or wrenches
- 2) 7/16" sockets or wrenches

### 3.3.5.1 Capstan Sprocket Installation

The equipment setup differs slightly from the steps in Section 3.3.7 when using a sprocket and chain servo gearbox. Substitute the below steps for steps 4 –6 of Section 3.3.7 to set up the fixture for a sprocket and chain type servo gearbox.

- 1) Refer to Figure 3-1 for the following steps.
- 2) Press sprocket alignment pins into top of fixture capstan.
- 3) Place sprocket on top of capstan using alignment pins as a guide.
- 4) Insert and tighten three sprocket mounting screws using #2 Phillips screwdriver.
- 5) Place chain connecting the unit capstan sprocket to the fixture capstan sprocket. Chain should be slack.
- 6) Continue Section 3.3.7 at step 7.

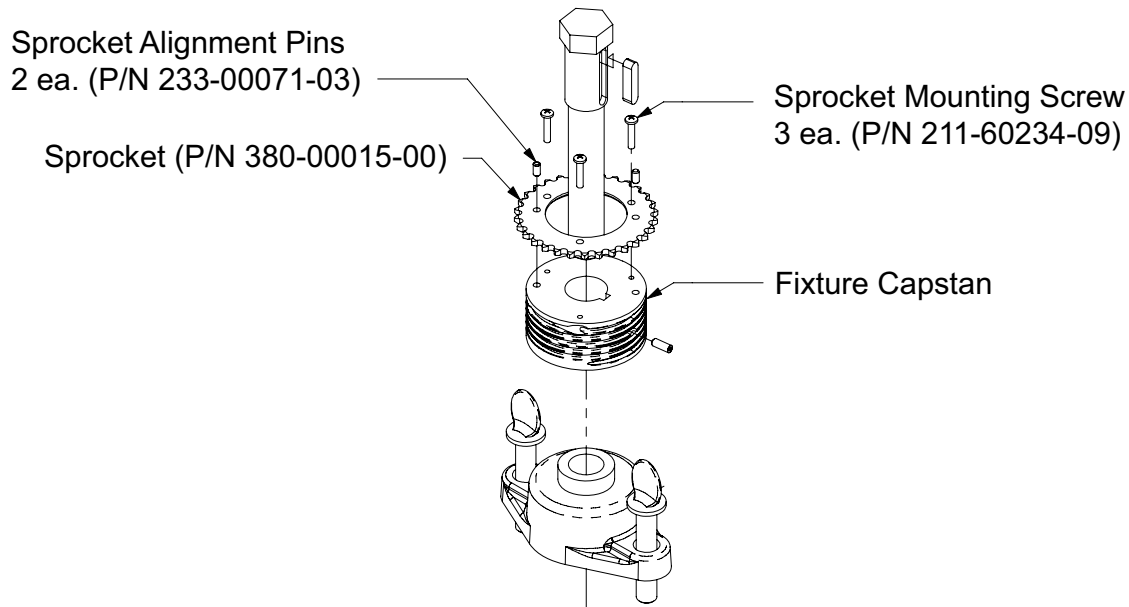

**Figure 3-1. Sprocket Capstan Assembly Drawing**

### 3.3.6 Special Instructions for Low Torque Servo Gearbox

During the slip-clutch adjustment of low torque units only (see Table 2-2 for part numbers), it may be necessary to add an extra washer under the castle nut used to adjust the slip clutch. Do not use this extra washer if setting a medium or high torque unit. The extra washer is provided in the GSM 85(A) Mounting Hardware Kit (011-01028-XX). If this part is not available, use an AN960-616 washer.

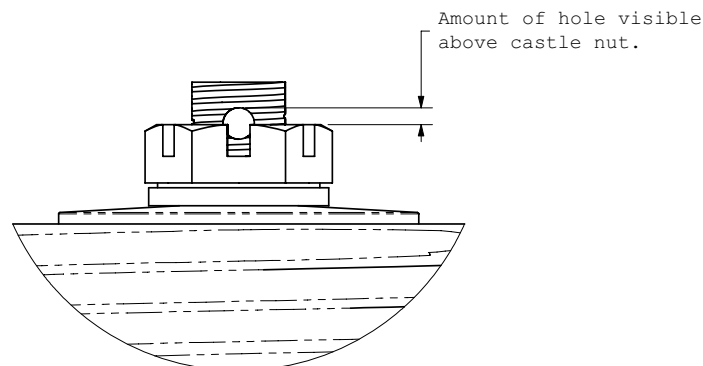

**Figure 3-2. Castle Nut Detail Drawing**

---

Do not install the extra washer unless necessary, as determined by the following steps:

- 1) Adjust the clutch to the desired setting on the Garmin clutch setting stand as described in Section 3.3.8.
- 2) Before installing the cotter pin, note how much of the cotter pin hole diameter is above the castle nut.
- 3) If more than half of the cotter pin diameter is above the nut castellation (see Figure 3-2), install the extra washer under the nut. If less than half of the cotter pin diameter is above the nut castellation, the extra washer is not needed, proceed with normal slip-clutch adjustment.

To install the extra washer, do the following steps:

- 1) Orient the servo gearbox with the shaft pointing up.
- 2) Remove only the castle nut. Do not disassemble the clutch or lift the capstan or hub any amount.
- 3) Install the extra washer directly on top of the existing washer.
- 4) Put the castle nut back on the shaft, hand tighten the nut to be sure that the slip clutch is not left loose.
- 5) The slip clutch may now be set again per paragraph 3.3.8.

### 3.3.7 Equipment Setup

- 1) Prepare fixture by ensuring that the electrical power supply is off, and that the clamps are loosened and ready to accept the unit. See Figure 3-3.

To view fixture using a sprocket and chain (rather than pulley and cable), see Figure 2-1.



**Figure 3-3. Slip-Clutch Adjustment Fixture (P/N T10-00110-01)**

- 
- 2) Place the unit on the fixture. Unit should easily sit down flat on the top of fixture. Do not force unit on to fixture. See Figure 3-4.



**Figure 3-4. Unit Placement**

- 3) Engage all necessary clamps to hold unit in place. Some units will use only 2 of the fixture clamps. Adjust clamp height and position to make sure that the unit is secure when clamps are fully engaged. See Figure 3-5.



**Figure 3-5. Clamp Adjustment**

### 3.3.7.1 Spiral 1/16" Cable Capstan

- 1) Insert swaged ball end into bottom end slot of fixture capstan, see Figure 3-6. Wrap cable around fixture capstan two full turns, beginning at the bottom, see Figure 3-7. For sprocket and chain method, refer to paragraph 3.3.5.1.

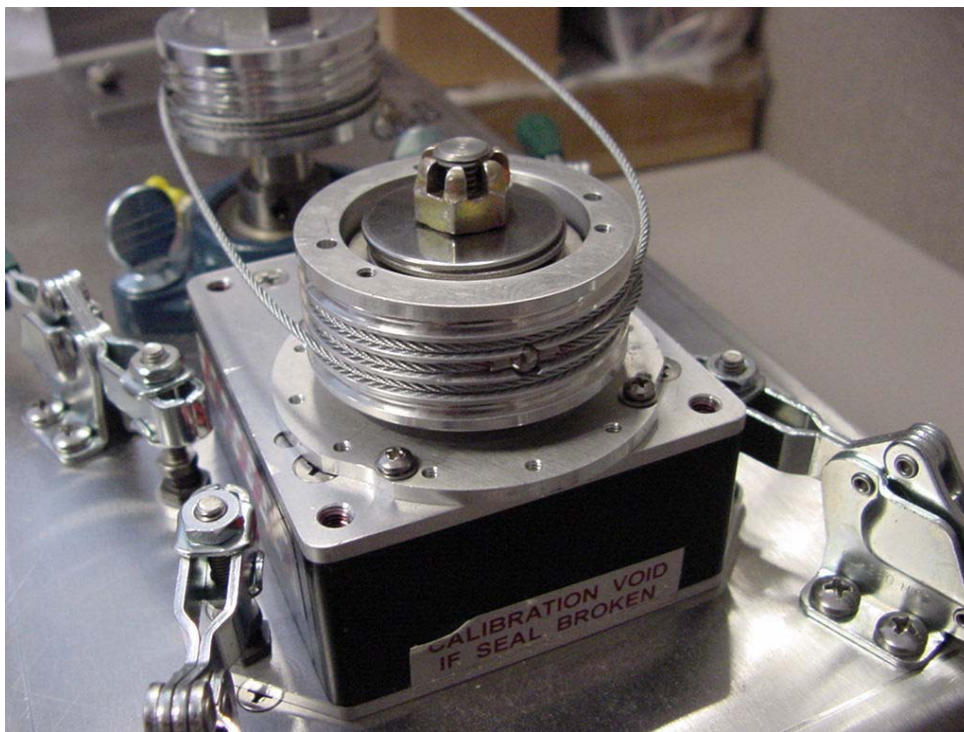

**Figure 3-6. Cable Placement (fixture capstan)**



**Figure 3-7. Cable Placement (fixture capstan)**

- 2) Wrap cable around unit capstan two and one half turns, with ball in center. See Figure 3-8. For sprocket and chain method, refer to paragraph 3.3.5.1.



**Figure 3-8. Cable Placement (unit capstan)**

- 
- 3) Finish by wrapping two more full turns around fixture capstan and slipping the swaged ball end into the top end slot of fixture capstan. Cable will be somewhat loose. See Figure 3-9. For sprocket and chain method, refer to paragraph 3.3.5.1. Continue to Section 3.3.7.5.



**Figure 3-9. Cable End Placement (unit capstan)**



### 3.3.7.2 Capstan Using 3/32" Cable w/Retainer Clips

- 1) Insert swaged ball end of the first cable (233-20003-00) into the top end slot of the unit capstan. See Figure 3-10.



**Figure 3-10. Inserting 3/32 cable in the unit capstan.**

- 2) Wrap the cable around the unit capstan approximately three and one half turns, leaving just enough cable to reach the bottom end slot of the test fixture capstan. See Figure 3-11. Turning the test fixture solenoid switch on will hold the unit capstan in place and make winding easier.

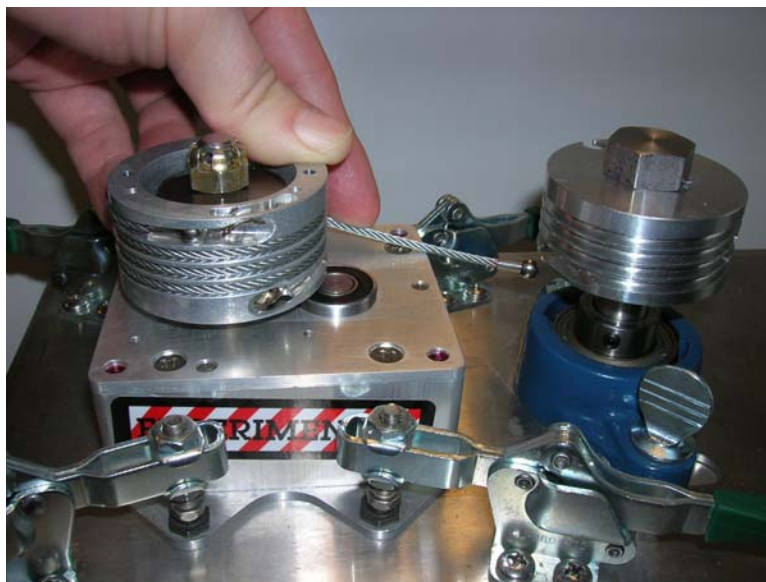

**Figure 3-11. Cable around unit capstan, showing end of cable near test fixture capstan bottom slot**

- 
- 3) Secure the swaged ball end in the bottom slot of the test fixture capstan. See Figure 3-12. If necessary, turn off the test fixture solenoid and turn the unit capstan to take up most of the slack in the cable. Turn the solenoid on again to keep the cable from unwinding.



**Figure 3-12. Cable inserted in bottom slot of fixture capstan**

- 4) Insert the swaged ball end of the second cable (233-20003-00) into the top end slot of the fixture capstan. See Figure 3-13.

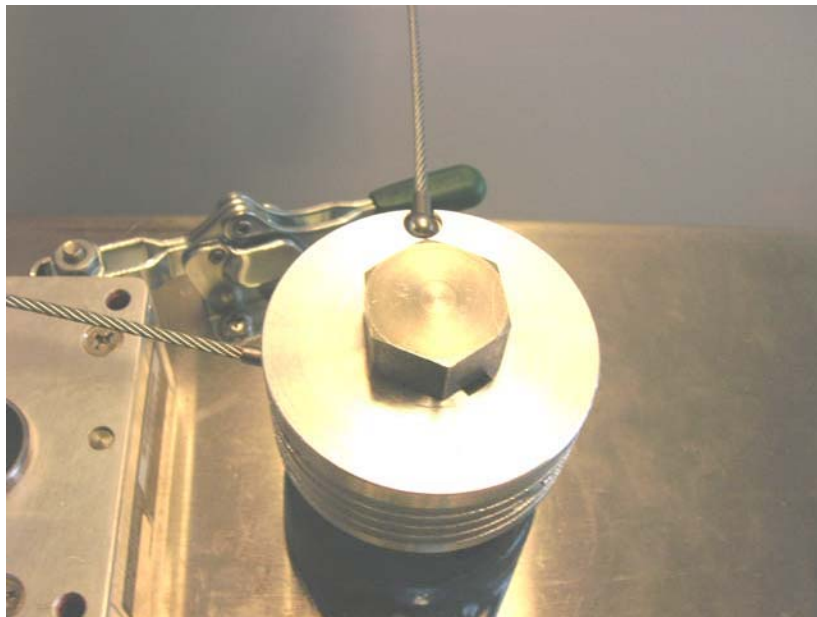

**Figure 3-13. Cable inserted in test fixture capstan top slot**

- 5) Wrap the cable around the fixture capstan approximately three and one half turns and then secure the remaining swaged ball end of the cable in the bottom end slot of the unit capstan. See Figure 3-14.



**Figure 3-14. Cable wrapped around test fixture capstan, remaining end installed in unit capstan bottom slot**

- 6) With the cables properly installed, the solenoid switch can be turned off and the capstans rotated to bring the cables to center of travel. See Figure 3-15. Continue to Section 3.3.7.5.

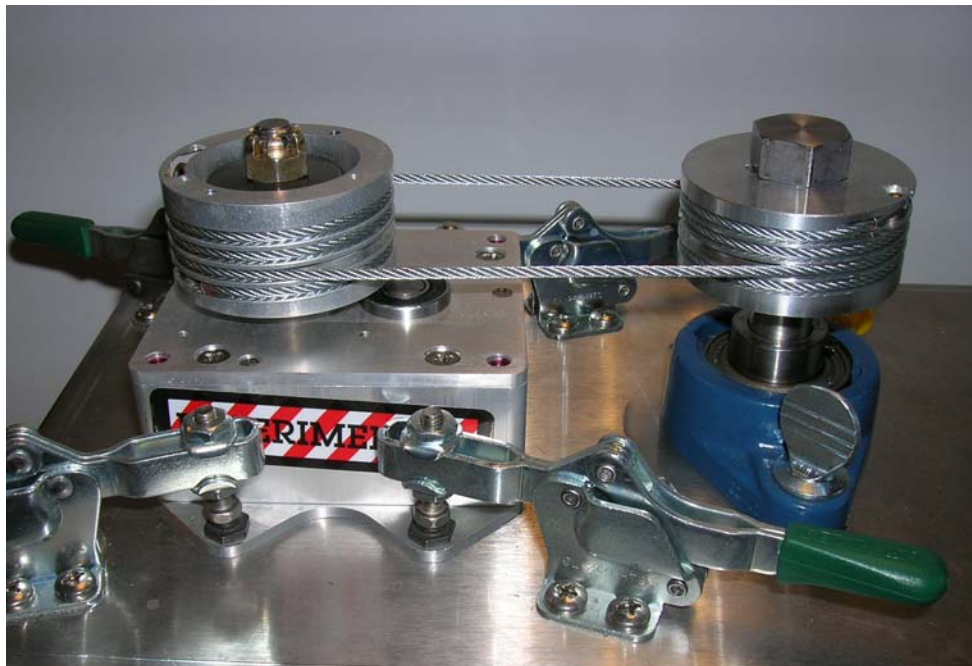

**Figure 3-15. 3/32 Cable with retainer clips at center of travel**

### 3.3.7.3 Continuous Travel Capstan

- 1) Insert swaged ball end of the cable (233-20002-00) into the bottom end slot of the fixture capstan (Figure 3-16). Wrap the cable around the capstan two and one half times, and then across to the bottom slot of the unit capstan (Figure 3-17).

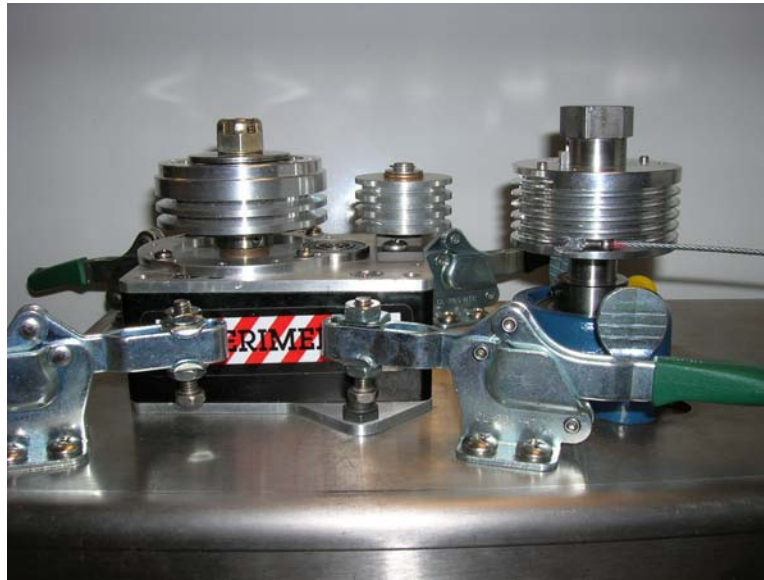
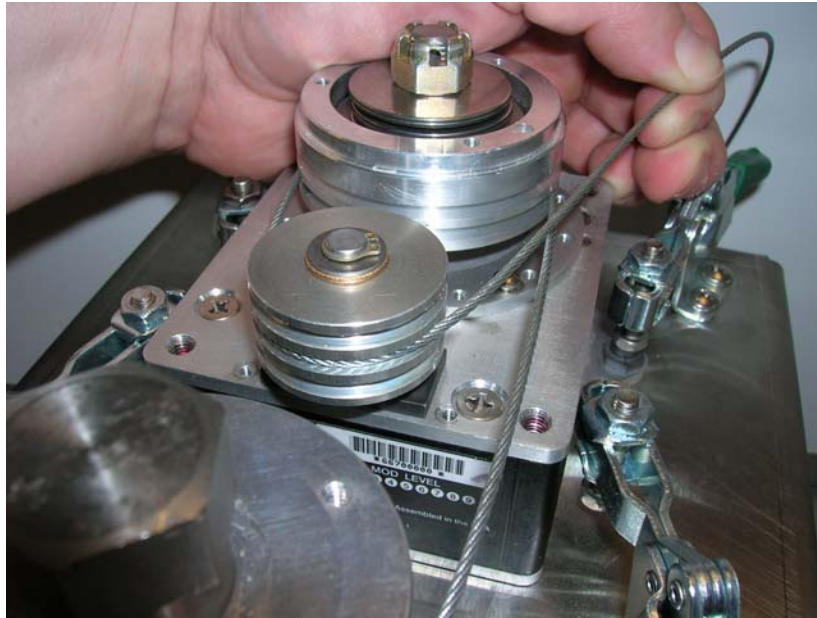

**Figure 3-16. Cable end inserted in bottom slot**



**Figure 3-17. Cable wrapped 2.5 times, going across to unit capstan lower slot**

- 2) Wrap the cable half of one turn around the unit capstan and then over to the middle slot of the idler pulley (Figure 3-18). Route the cable around the idler pulley one half turn and then back to the unit capstan upper slot (Figure 3-19). Wrap the cable one half turn around the upper slot of the unit capstan and then across to the lowest empty groove of the fixture capstan (Figure 3-20).



**Figure 3-18. Cable wrapped around idler middle slot**



**Figure 3-19. Cable wrapped around unit upper slot**



**Figure 3-20. Cable routed to fixture capstan**

- 3) Wrap the cable another one and a half turns around the fixture capstan, bringing the end of the cable to the upper end slot of the fixture capstan (Figure 3-21). Guide the swaged ball into the end slot. Continue to Section 3.3.7.5.



**Figure 3-21. Cable wrapped and inserted in upper slot of fixture capstan**



**Figure 3-22. Slack taken up, capstan centered**

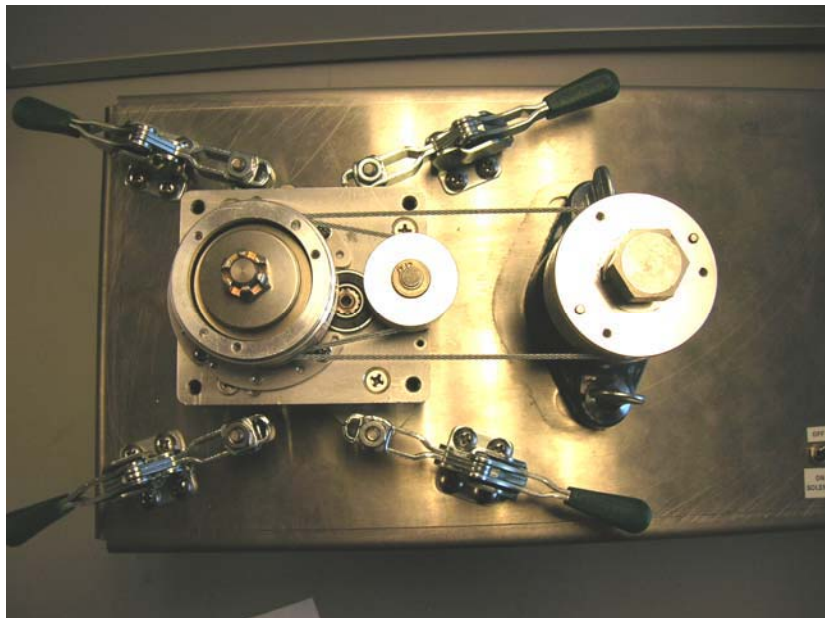

**Figure 3-23. Slack taken up, capstan centered (view from top)**

---

### 3.3.7.4 Chain and Sprocket Capstan

- 1) For sprocket type units, install the chain (233-30001-01) by engaging the teeth on the unit sprocket. See Figure 3-24 and 3-25.



**Figure 3-24. Sprocket capstan installed on fixture**

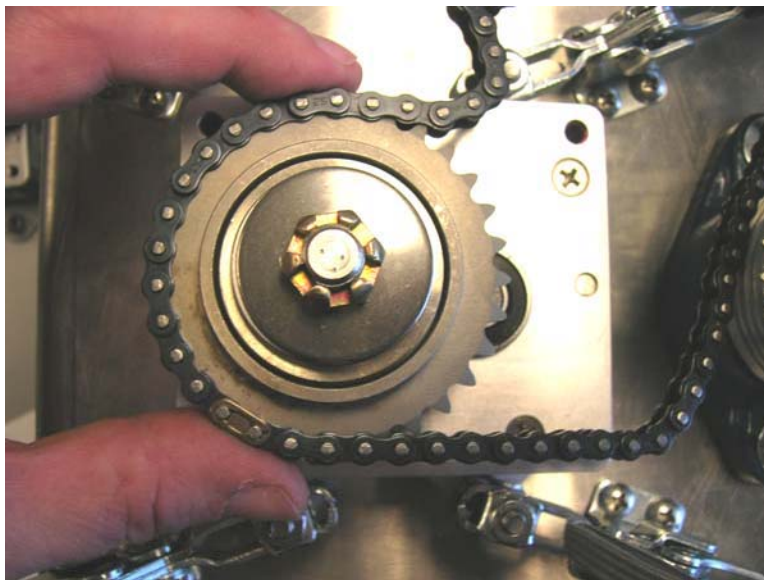

**Figure 3-25. Chain around unit sprocket**

- 2) Support the chain to keep the teeth of the sprockets engaged while installing the chain on the test fixture sprocket (Figure 3-26).



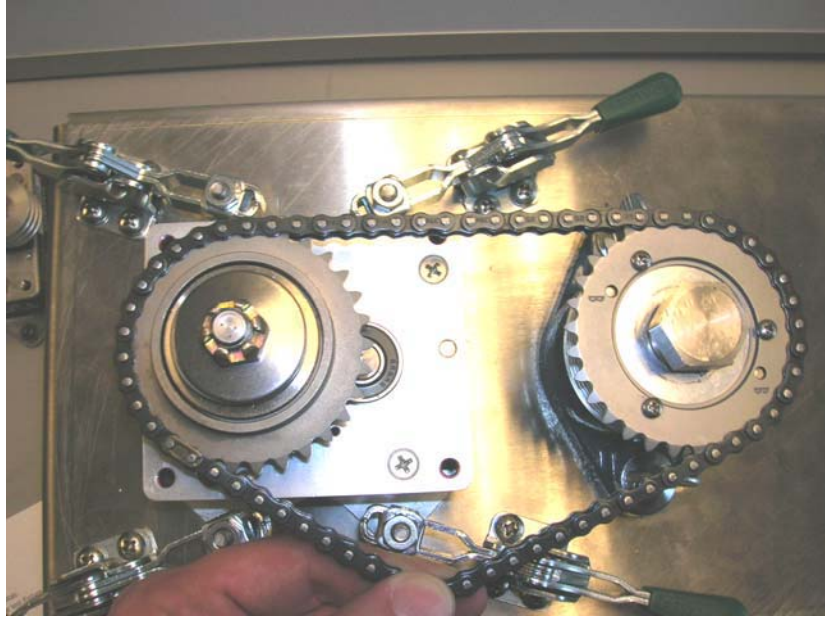

**Figure 3-26. Chain engaged on both sprockets, supported by hand**

- 3) Turn the fixture adjustment knob enough to ensure the chain stays engaged on both fixture and unit sprockets (Figure 3-27). Continue to Section 3.3.7.5.



**Figure 3-27. Chain slack removed**

### 3.3.7.5 All Versions

- 1) Pull slack out of cable (or chain) using fixture adjustment knob. Do not over-tighten knob. When properly adjusted, remaining slack in cable (or chain) should allow for approximately 0.25" deflection (using finger pressure) midway between the fixture capstan and the unit capstan (Figure 3-28).

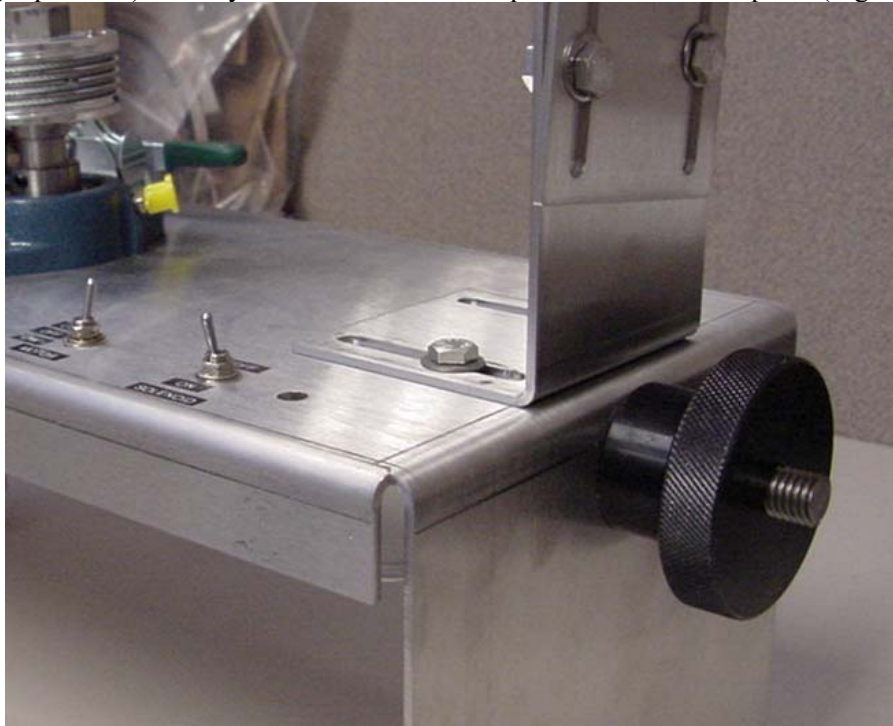

**Figure 3-28. Fixture Adjustment Knob**

- 2) Secure fixture capstan and bearings by tightening two wing-nuts on bottom of fixture while holding top thumb screw ends. Hand tight is sufficient. See Figure 3-29.

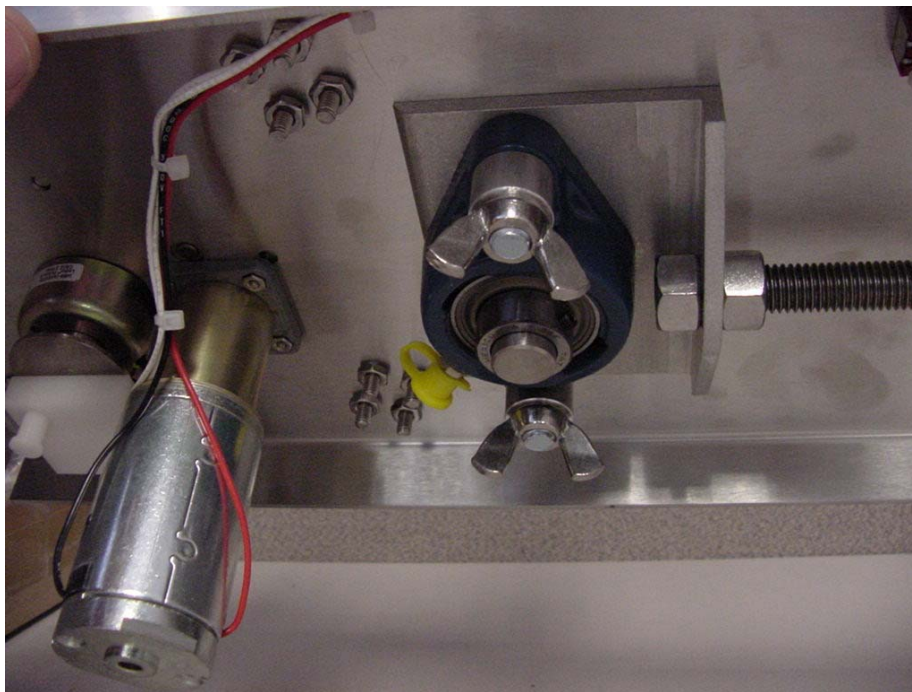

**Figure 3-29. Fixture Adjustment Wingnuts**

- 
- 3) Install torque wrench on top of the fixture capstan using the 13/16" socket. Make sure that the torque wrench is initially set to zero torque before placing it in the fixture. The torque wrench support should be adjusted to hold the torque wrench level. The torque wrench support bolts should be tightened sufficiently to prevent movement of the support when torque is applied. See Figure 3-30.

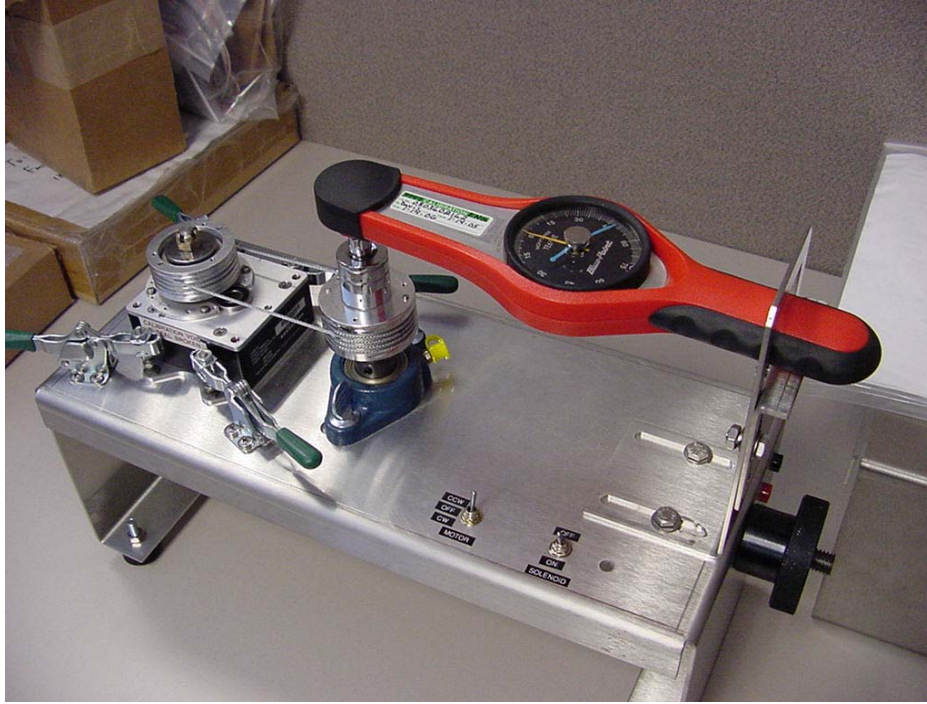

**Figure 3-30. Torque Wrench Placement**

### 3.3.8 Slip-Clutch Adjustment

- 1) Connect 24V +/- 0.5VDC from the electrical power supply to the Garmin Slip-Clutch Fixture using banana jacks. Turn power supply on.
- 2) Engage the solenoid.
- 3) Run the motor clockwise.
- 4) Using the 9/16" wrench, adjust the slip-clutch adjustment (castle) nut until the torque value indicates the required setting.
- 5) Switch the motor direction to counter clock-wise and adjust the castle nut until the torque value is within the required range.
- 6) Switch the motor direction back and forth and adjust castle nut as needed until the required torque range is achieved in both directions. Make sure that the holes in the shaft are centered within the notches of the castle nut.
- 7) Run the capstan two full turns in each direction while observing the torque reading. If the torque reading remains within the required range without any adjustment of the castle nut, proceed to step 8. If not, return to step 6.
- 8) If the GSM85 is a low torque unit, refer to paragraph 3.3.6 before inserting the cotter pin. Insert the cotter pin (MS24665-283) into the holes in the shaft (through the notches in the castle nut). Bend the cotter pin ends to keep the pin in place, using standard cotter pin practices.
- 9) Relieve torque from torque wrench by following step 3.3.2.3 before removing unit from fixture.
- 10) Remove unit from fixture by reversing steps in Section 3.3.7.

#### To remove cable from retaining clips:

If the servo gearbox capstan has retaining clips, the swaged ball end of the cable can be removed by sliding the ball past the clip while pressing the retaining clip with a flat screwdriver or similar tool.

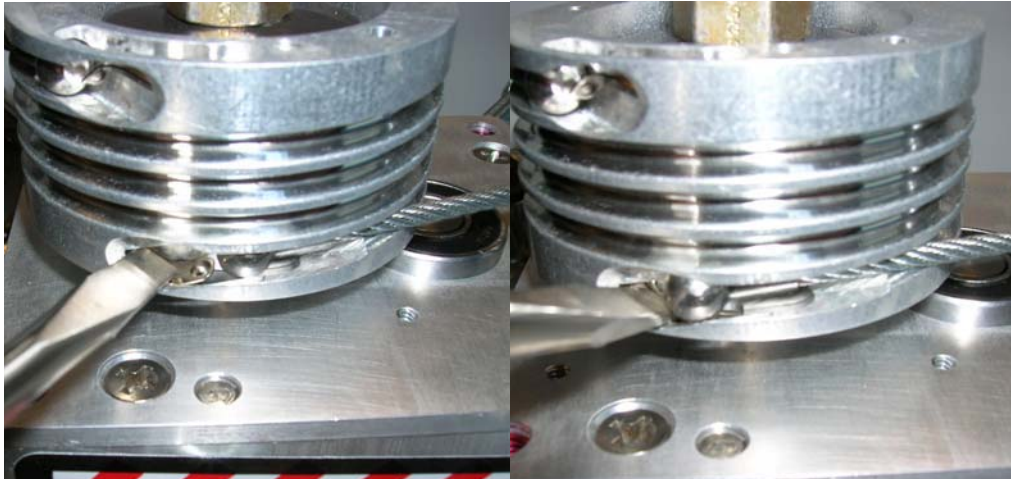

**Figure 3-31. Removing Swaged Ball from Retaining Clip**

---

## 3.4 GSA/GSM Installation

|                |
|----------------|
| <b>CAUTION</b> |
|----------------|

The GSA 8X and GSM 85(A) should be installed according to Type Certification (TC) or Supplemental Type Certification (STC) approved aircraft-specific installation drawings. The information in this section is provided as guidance, and does not take precedence over installation procedures defined in aircraft-specific GFC 700 installation data.

1. Prepare the servo installation site. Make sure that the servo bracket(s) are installed securely to the airframe. Make sure that the servo gearbox cutouts are made according to the dimensions listed in Appendix A, for the correct servo gearbox. If the applicable cableguard or chainguard ring is not already installed to the front of the servo, (refer to applicable drawing in Appendix A) install the cableguard or chainguard ring using four #4-40 machine screws and lock washers as supplied in the cableguard ring kit (011-01336-XX) or chainguard ring kit (011-01375-XX). The four cableguard or chainguard ring mounting screws should be torqued to 10 in/lbs (+/- 2 in/lbs).
2. Fasten the GSM 85(A) to the correct structural bracket using four AN3 bolts torqued to 45 in/lbs (+/- 5 in lbs) and AN960-10 washers.
3. Attach the aircraft control surface cabling/chains to the output pulley or sprocket following guidance provided in Appendix A of this document, along with guidance from the aircraft manufacturer.
4. Assemble the capstan cover and standoffs as shown in Appendix A. Refer to aircraft-specific installation documentation for proper location of standoffs to provide proper support of the capstan cover. Use the machine screws and lock washers to install the capstan cover, these screws should be torqued to 10 in/lbs (+/- 2 in/lbs).
5. Apply grease to the output gear of the GSA 8X, in accordance with the applicable airframe specific G1000 line maintenance manual, if required. Grease is required if the servo has been removed for periodic inspection or maintenance. Grease is recommended any time the servo and servo gearbox are separated. If both servo and servo gearbox are new, grease is not required, as sufficient grease is applied to the servo gearbox during its manufacture.
6. Carefully mate the GSA 8X with the GSM 85(A), noting the correct orientation for the gears to line up. Fasten the GSA 8X to the GSM 85(A) using AN3-4A bolts torqued to 45 in-lbs (+/- 5 in lbs) with AN960-10L washers (or using AN3-5A bolts with two AN960-10 washers per bolt). Mounting hardware to be provided by the installing agency.
7. Connect the GSA 8X connector to the aircraft harness. Make sure that the harness is properly secured to the airframe.
8. After all servos are installed and all aircraft control surfaces connected, continue to Section 3.5.

---

## 3.5 Post Installation Configuration & Checkout

|             |
|-------------|
| <b>NOTE</b> |
|-------------|

The GFC 700 system does not allow operation of the flight-control system until the required post installation configuration procedures have been completed.

The GSA 8X and GSM 85(A) must be installed with a Garmin G1000 system and have FAA approved software loaded.

AFCS software is loaded to the GIAs and GSA 8X servos from an aircraft-specific G1000 Software Loader Card.

The PFD serves as the graphical user interface to load the software. For actual aircraft installation/checkout, refer to aircraft-specific approved checkout procedures.

## 3.6 Continued Airworthiness

Refer to aircraft-specific documentation for actual ICA procedures.

### 3.6.1 GSA 8X Servos

Conduct a visual inspection every 1000 hours or every annual, whichever occurs first.

Clean and apply grease (MIL-G-21164D or equivalent) to output gear every 1000 hours or 3 years, whichever occurs first.

### 3.6.2 GSM 85(A) Gearbox

Conduct a visual inspection and check slip clutches every 500 hours or every annual, whichever occurs first.

## 4 SYSTEM INTERCONNECTS

### 4.1 GSA 8X Pin Function List

#### 4.1.1 P801

Figure 4-1 shows a view of the J801 connector, as looking at the connector. Table 4-1 lists the pin names and specifies each applicable pin as an input or output. Table 4-2 lists only the electrical power pins.

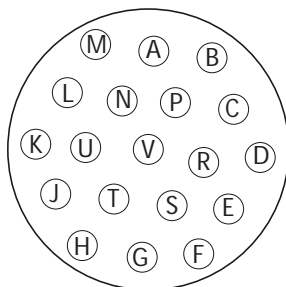

Figure 4-1. J801 Connector Layout

Table 4-1. J801 Connector I/O

| Pin | Pin Name        | I/O |
|-----|-----------------|-----|
| A   | Spare           | --  |
| B   | Spare           | --  |
| C   | Spare           | --  |
| D   | Spare           | --  |
| E   | RS-485 2 B      | I/O |
| F   | SERVO PROGRAM 3 | In  |
| G   | SERVO PROGRAM 2 | In  |
| H   | SERVO PROGRAM 1 | In  |
| J   | RS-485 1 A      | I/O |
| K   | Spare           | --  |
| L   | Spare           | --  |
| M   | Spare           | --  |
| N   | AIRCRAFT POWER  | In  |
| P   | AP DISCONNECT   | In  |
| R   | PROGRAM GROUND  | --  |
| S   | RS-485 2 A      | I/O |
| T   | RS-485 1 B      | I/O |
| U   | PROGRAM GROUND  | --  |
| V   | POWER GROUND    | --  |

### 4.2 Power

Table 4-2. J801 Connector Power Pins I/O

| Pin | Pin Name       | I/O |
|-----|----------------|-----|
| N   | AIRCRAFT POWER | In  |
| P   | AP DISCONNECT  | In  |
| V   | POWER GROUND   | --  |

The GSA 8X accepts power from 28-volt aircraft electrical systems. Aircraft power is supplied to the GSA 8X through two power-input pins labeled AIRCRAFT POWER and AP DISCONNECT. AIRCRAFT POWER (Pin N) supplies power to the GSA 8X micro-controller, and associated circuitry, whereas AP DISCONNECT (Pin P) supplies power to the drive motor and the engagement solenoid. Aircraft power is routed to the AP DISCONNECT pin through the normally closed AP DISC switch in the aircraft. Whenever the AP DISC switch is depressed, power to the motor-drive and solenoid-drive circuits is interrupted, thereby guaranteeing removal of motor and solenoid current.

### 4.3 RS-485 Serial Data

The GSA 8X communicates with the GIA 63/GIA 63W over two RS-485 serial ports. Two unique protocols are used, one for startup and bench testing, and the other for normal operations.

**Table 4-3. RS-485 Pins**

| Pin | Pin Name   | I/O |
|-----|------------|-----|
| J   | RS-485 1 A | I/O |
| T   | RS-485 1 B | I/O |
| S   | RS-485 2 A | I/O |
| E   | RS-485 2 B | I/O |

### 4.4 Servo Program Inputs

The servo program inputs (listed in Table 4-4) are installation straps that program the GSA 8X servo actuator to function in the appropriate flight-control axis, as defined by Table 4-5. The avionics installer grounds the appropriate program line(s) of the GSA 8X to the program ground pin(s), per Table 4-5 to force the desired servo functionality. The GSA 8X read the states of these lines once, at power-up to determine the required servo functionality.

**Table 4-4. Servo Program Inputs**

| Pin | Pin Name        | I/O |
|-----|-----------------|-----|
| H   | SERVO PROGRAM 1 | In  |
| G   | SERVO PROGRAM 2 | In  |
| F   | SERVO PROGRAM 3 | In  |

**Table 4-5. Servo Function Logic Table**

| Servo Program Pins          |                             |                             | Servo Function |
|-----------------------------|-----------------------------|-----------------------------|----------------|
| Pin F<br>SERVO<br>PROGRAM 3 | Pin G<br>SERVO<br>PROGRAM 2 | Pin H<br>SERVO<br>PROGRAM 1 |                |
| Open                        | Open                        | Open                        | Bench-Test     |
| Open                        | Open                        | Ground                      | Pitch Primary  |
| Open                        | Ground                      | Open                        | Roll Primary   |
| Open                        | Ground                      | Ground                      | Yaw Primary    |
| Ground                      | Open                        | Open                        | Pitch Trim     |
| Ground                      | Open                        | Ground                      | Roll Trim      |
| Ground                      | Ground                      | Open                        | Yaw Trim       |
| Ground                      | Ground                      | Ground                      | Boot-Block     |



# APPENDIX A

## OUTLINE AND INSTALLATION DRAWINGS

### A.1 INTRODUCTION

This section contains the outline and installation drawings to aid in the installation of the GSA and GSM series products. Additional information and notes included on the drawings can be used as reference during the installation.

### A.2 DRAWING LIST

Table A-1 lists the current model numbers, and the applicable drawings that are included in this section.

**Table A-1. OUTLINE AND INSTALLATION DRAWING LIST**

| MODEL NUMBER           | DESCRIPTION  | APPLICABLE DRAWING |
|------------------------|--|--------------------|
| 011-00877-00           | GSA 80 Servo Actuator                                    | A-1                |
| 011-00878-00           | GSA 81 Servo Actuator                                    | A-2                |
| 011-00878-10           | GSA 81 Servo Actuator                                    | A-3                |
| 011-00894-00, -07      | GSM 85 Servo Gearbox for 1/16" cable, 2 bolt             | A-4, A-14          |
| 011-00894-08, -10      | GSM 85 Servo Gearbox for 1/16" cable, 4 bolt             | A-5, A-14          |
| 011-00894-11           | GSM 85 Servo Gearbox for 3/32" Cable                     | A-6                |
| 011-00894-02           | GSM 85 Servo Gearbox, Continuous Travel                  | A-7, A-15          |
| 011-00894-04           | GSM 85 Servo Gearbox with Sprocket                       | A-8                |
| 011-00894-09           | GSM 85 Universal Hub Servo Gearbox                       | A-9                |
| 011-01436-00, -01      | GSM 85A Servo Gearbox for 3/32" Cable                    | A-10, A-14         |
| 011-01436-02, -03      | GSM 85A Servo Gearbox for 1/16" Cable                    | A-11, A-14         |
| 011-01436-04, -05, -06 | GSM 85A Servo Gearbox with Universal Hub                 | A-12               |
| 011-01436-07, -08      | GSM 85A Servo Gearbox for 1/16" Cable, Continuous Travel | A-13, A-15         |

---

This page intentionally left blank

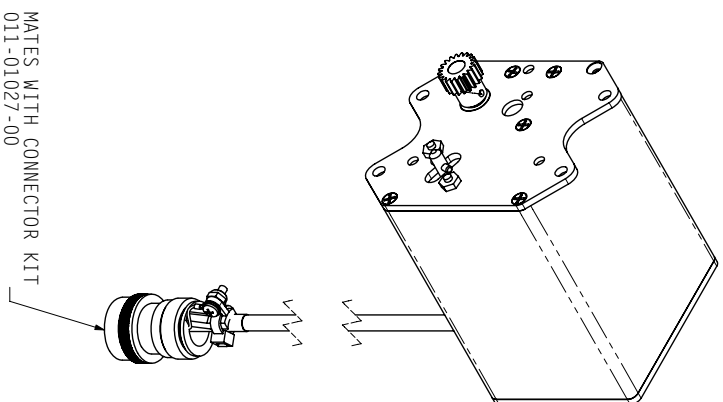
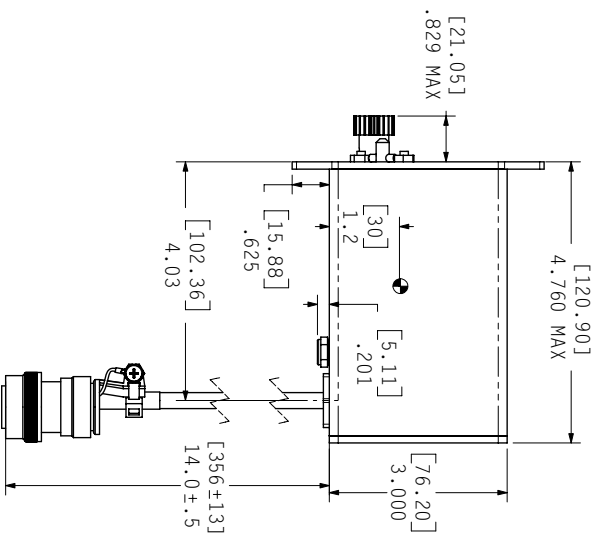
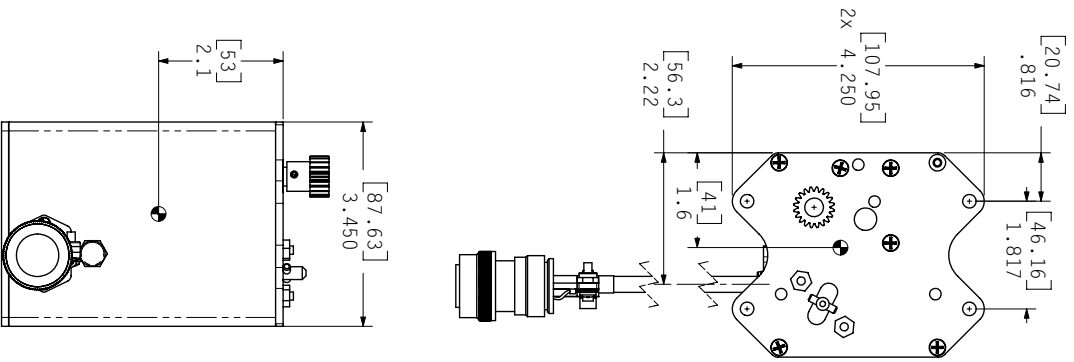

011-00877-00

- NOTES:
1. DIMENSIONS IN INCHES [MM]
  2. TOLERANCES (UNLESS OTHERWISE NOTED):
- |      |        |     |       |
|------|--------|-----|-------|
| .X   | ±0.1   | X   | ±3    |
| .XX  | ±0.04  | .X  | ±1.0  |
| .XXX | ±0.020 | .XX | ±0.51 |
|      | INCH   |     | MM    |

Figure A-1. GSA 80 Outline Drawing

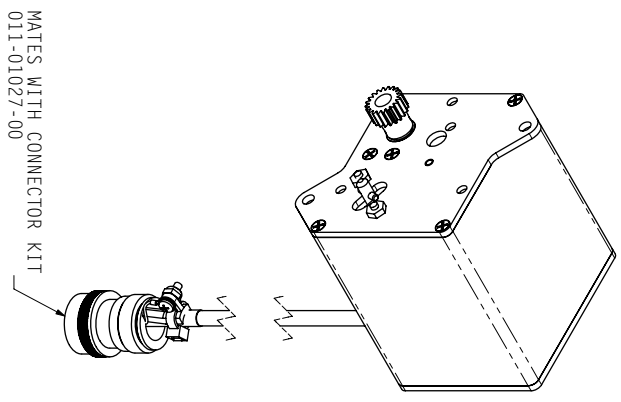
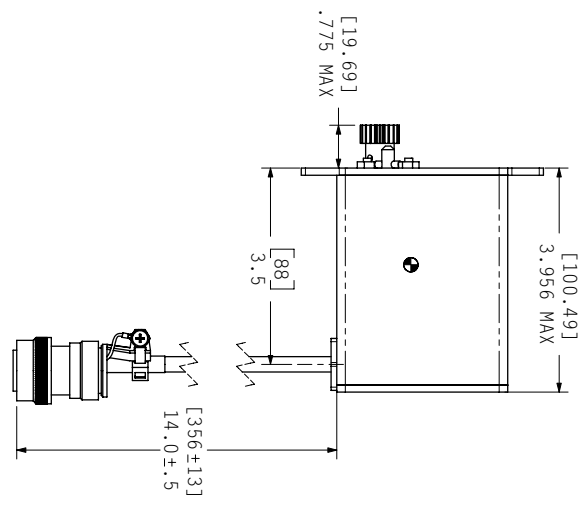
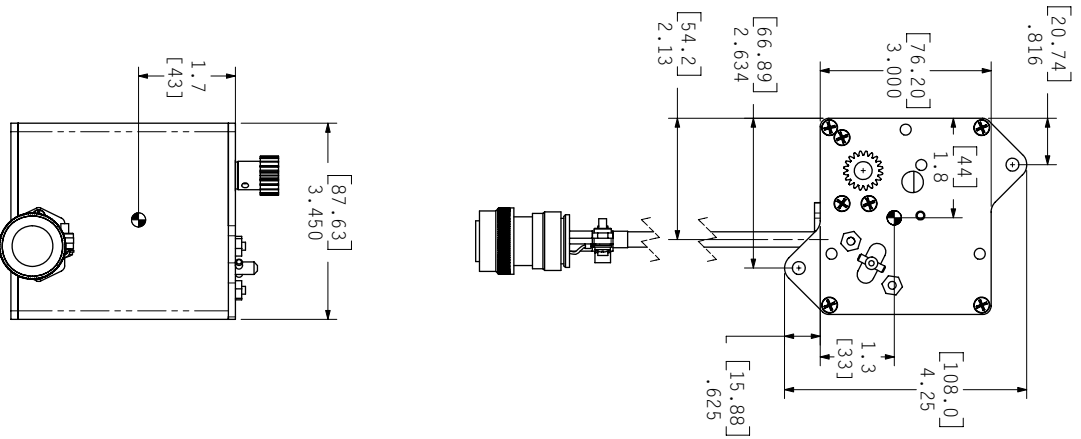

**011-00878-00**

- NOTES:  
 1. DIMENSIONS IN INCHES [MM]  
 2. TOLERANCES (UNLESS OTHERWISE NOTED):

| INCH | MM        |
|------|-----------|
| .X   | X ±.1     |
| .XX  | X ±0.04   |
| .XXX | X ±0.020  |
|      | X ±.3     |
|      | X ±1.0    |
|      | .XX ±0.51 |

Figure A-2. GSA 81 (-00) Outline Drawing

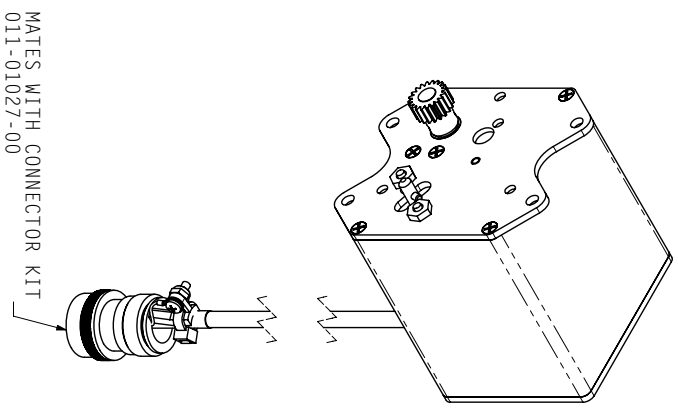
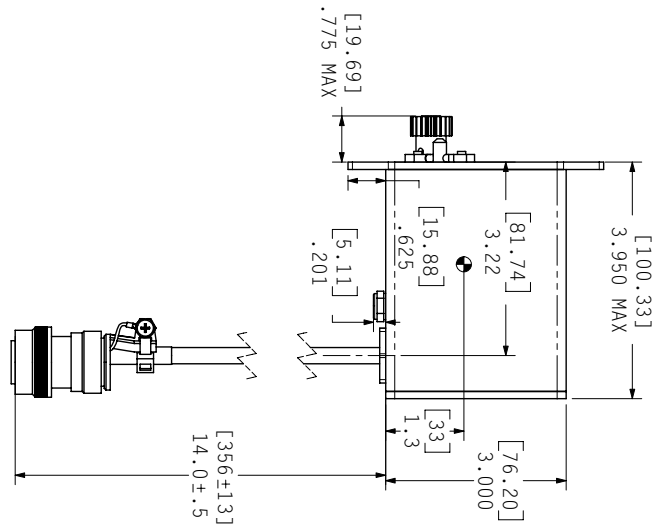
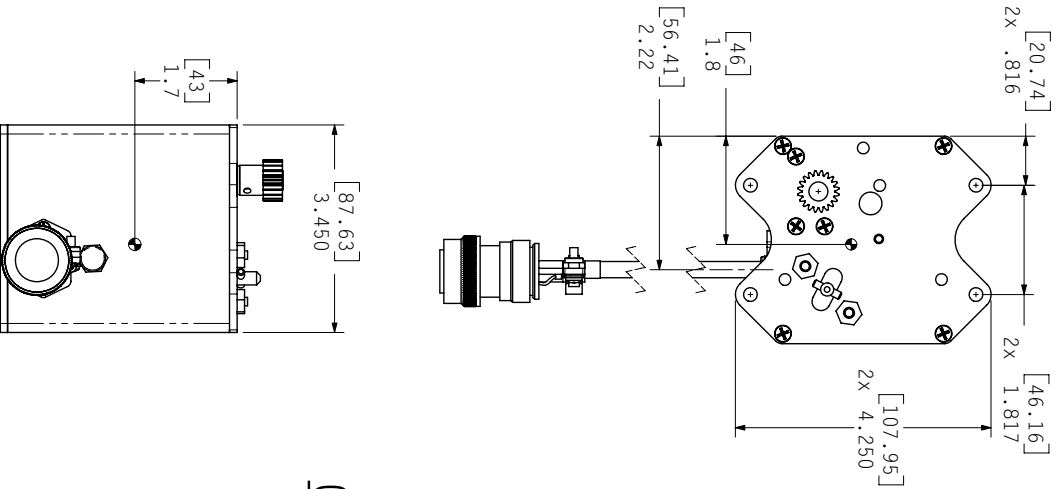

# 011-00878-10

- NOTES:
1. DIMENSIONS IN INCHES [MM]
  2. TOLERANCES (UNLESS OTHERWISE NOTED):

|      |        |     |       |
|------|--------|-----|-------|
| .X   | ±0.1   | X   | ±3    |
| .XX  | ±0.04  | .X  | ±1.0  |
| .XXX | ±0.020 | .XX | ±0.51 |
|      | INCH   | mm  |       |

Figure A-3. GSA 81 (-10) Outline Drawing

GSM 85 SERVO GEARBOX  
FOR 1/16" CABLE, 2 BOLT  
011-00894-00, -07

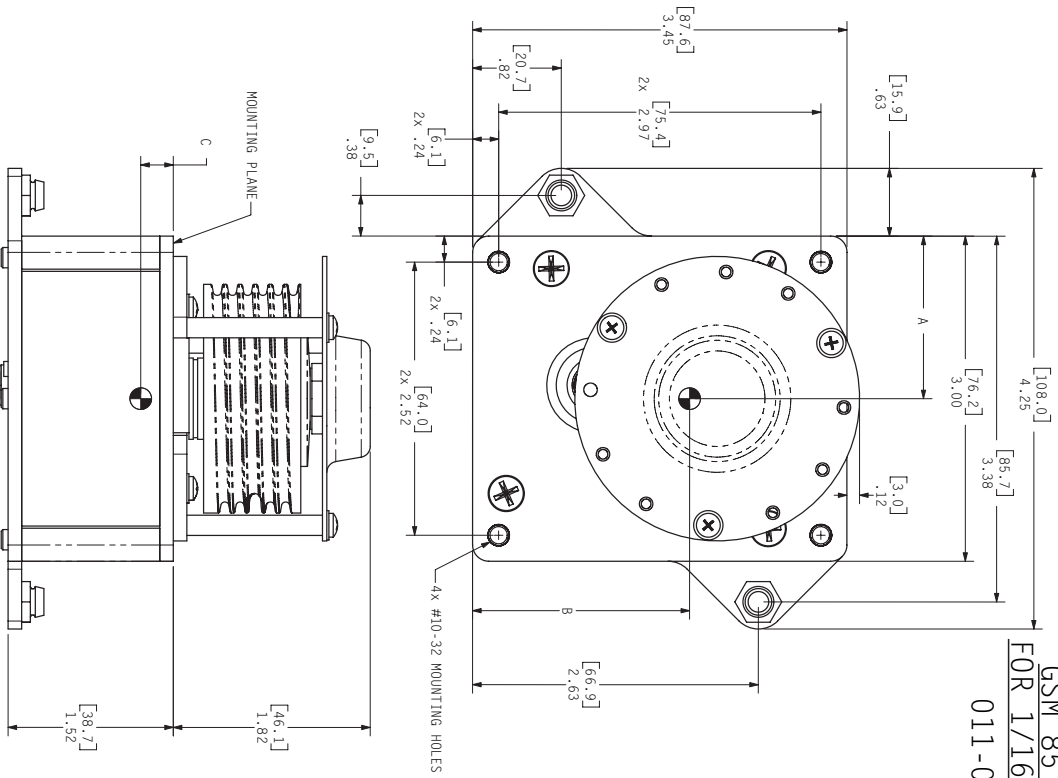

CAPSTAN COVER, STANDOFFS, SCREWS, AND WASHERS CONTAINED IN 011-01028-00 MOUNTING KIT  
ALL CABLEGUARD RING SCREWS, CAPSTAN COVER SCREWS AND STANDOFFS TO BE TIGHTENED TO 10 +/- 2 IN.-LBS.

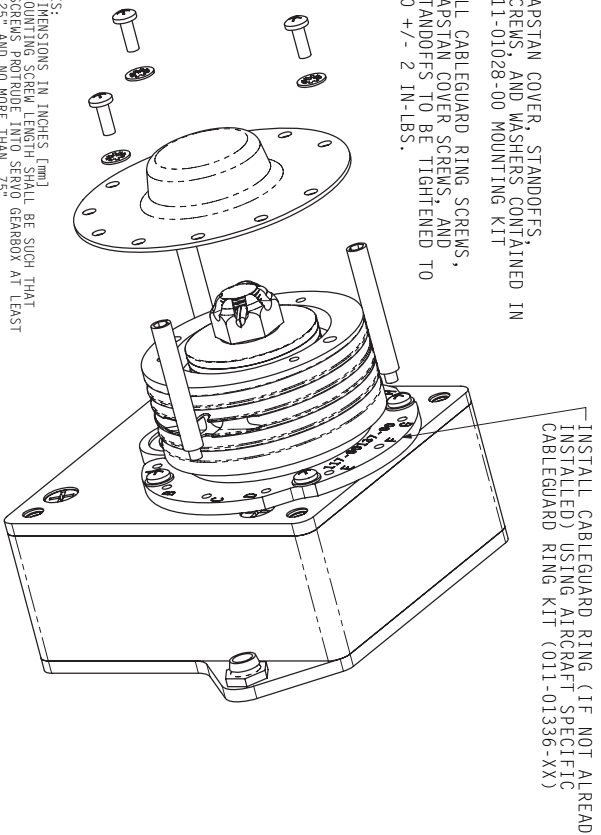

- NOTES:
1. DIMENSIONS IN INCHES (mm)
  2. MOUNTING SCREW LENGTH SHALL BE SUCH THAT SCREWS PROTRUDE INTO SERVO GEARBOX AT LEAST .25" AND NO MORE THAN .75"
  3. RECOMMENDED DEPTH IS .25"
  4. USE MS20663-2 DOUBLE SHANK BALL ON CAPSTAN
  5. PITCH DIAMETER OF CABLE WRAPPED ON CAPSTAN IS 1.97
  6. TOTAL CAPSTAN GROOVE LENGTH FROM END OF FULL DEPTH GROOVE TO END OF FULL DEPTH GROOVE CENTER IS 9 TURNS WITH LOCKING BALL SLOT
  7. COTTER PIN IS MS2465-283

| Center of Gravity Location | A (in) | B (in) | C (in) |
|----------------------------|--------|--------|--------|
| Dimension                  | 1.5    | 2.0    | 0.3    |

TOLERANCES FOR ALL PAGES OF DWG (UNLESS OTHERWISE NOTED):

|      |        |     |       |
|------|--------|-----|-------|
| .X   | ±0.1   | X   | ±3    |
| .XX  | ±0.04  | .X  | ±1.0  |
| .XXX | ±0.020 | .XX | ±0.51 |

Figure A-4. GSM 85 Servo Gearbox For 1/16" Cable, 2 Bolt (Sheet 1 of 2)

GSM 85 SERVO GEARBOX  
FOR 1/16" CABLE, 2 BOLT  
011-00894-00, -07

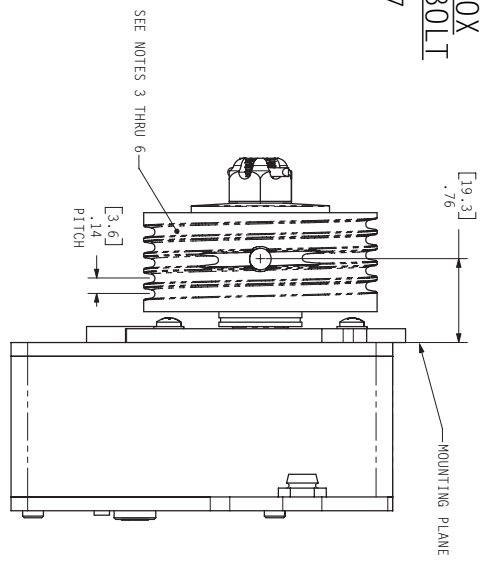
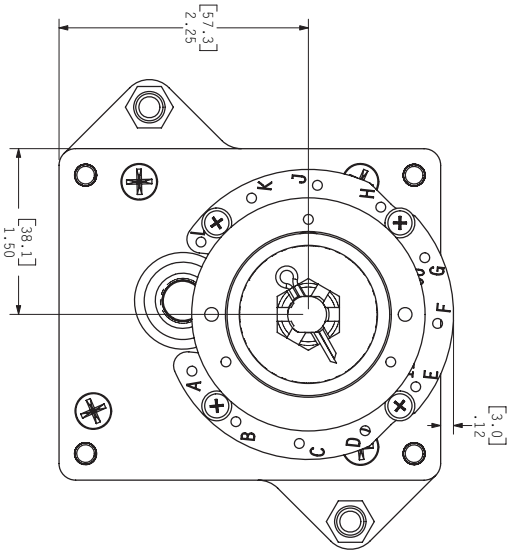

BRACKET CUT-OUT DIMENSIONS  
SCALE 1:2

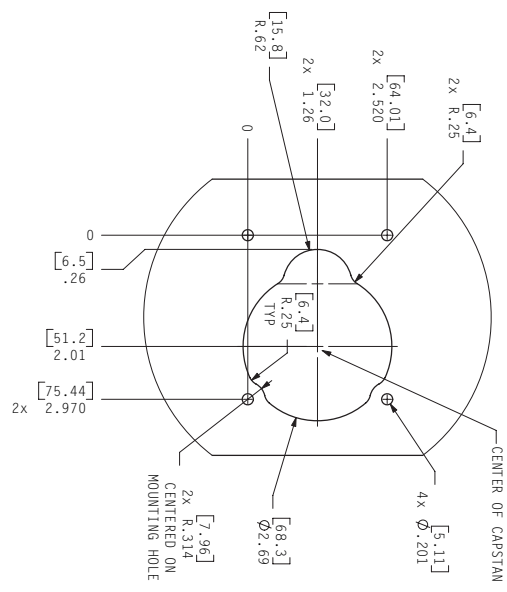
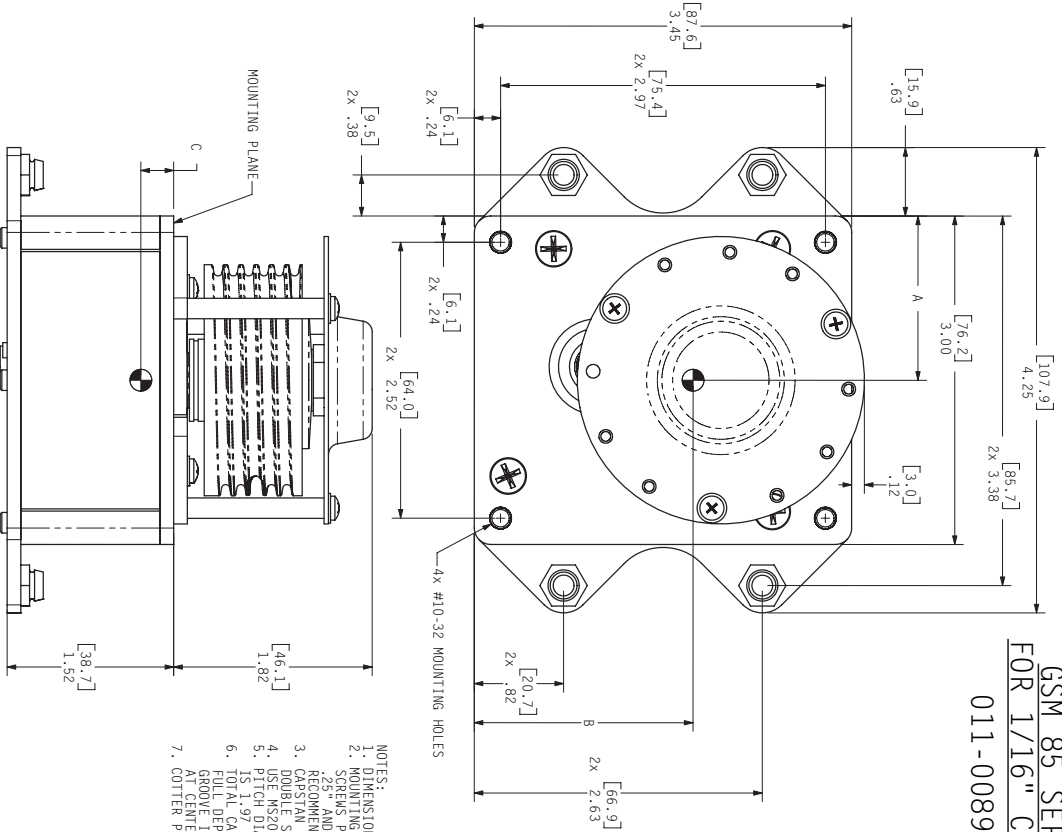

Figure A-4. GSM 85 Servo Gearbox For 1/16" Cable, 2 Bolt (Sheet 2 of 2)

GSM 85 SERVO GEARBOX  
FOR 1/16" CABLE, 4-BOLT  
011-00894-08, -10



- NOTES:
1. DIMENSIONS IN INCHES [mm]
  2. MOUNTING SCREW LENGTH SHALL BE SUCH THAT SCREWS PROTRUDE INTO SERVO GEARBOX AT LEAST RECOMMENDED DEPTH IN INCHES
  3. CAPSTAN DESTIGED FOR 1/16" CABLE WITH DOUBLE SHANK BALL
  4. USE MS20663-2 DOUBLE SHANK BALL ON CABLE
  5. PITCH DIAMETER OF CABLE WRAPPED ON CAPSTAN IS 1.97
  6. FULL DEPTH GROOVE TO END OF FULL DEPTH GROOVE IS 5 TURNS WITH LOCATING BALL SLOT AT CENTER
  7. CUTTER PIN NUMBER IS MS24665-283

ALL CABLEGUARD RING, SCREWS, CAPSTAN COVER SCREWS, AND STANDOFFS TO BE TIGHTENED TO 10 +/- 2 IN-LBS.

CAPSTAN COVER, STANDOFFS, SCREWS, AND WASHERS CONTAINED IN 011-01028-00 MOUNTING KIT

INSTALL CABLEGUARD RING (IF NOT ALREADY INSTALLED) AS CALLED OUT IN AIRCRAFT SPECIFIC INSTALLATION INSTRUCTIONS.

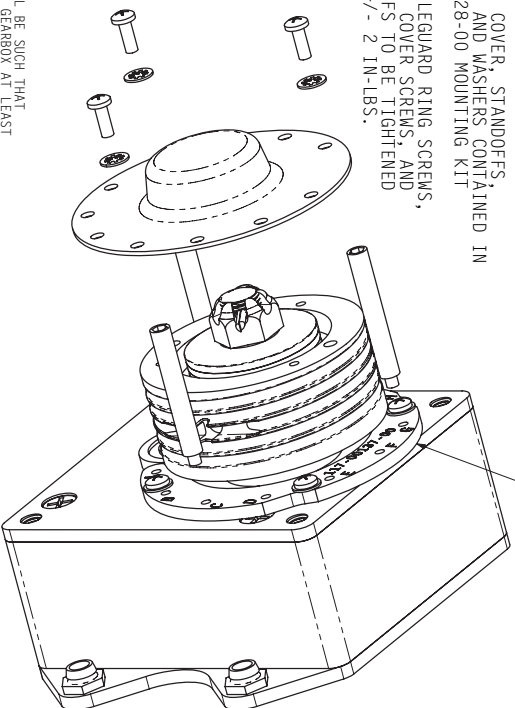

| Center of Gravity Location |        |        |        |
|----------------------------|--------|--------|--------|
| Dimension                  | A (in) | B (in) | C (in) |
|                            | 1.5    | 2.0    | 0.3    |

Figure A-5. GSM 85 Servo Gearbox For 1/16" Cable, 4 Bolt (Sheet 1 of 2)



GSM 85 SERVO GEARBOX  
FOR 1/16" CABLE, 4-BOLT  
011-00894-08, -10

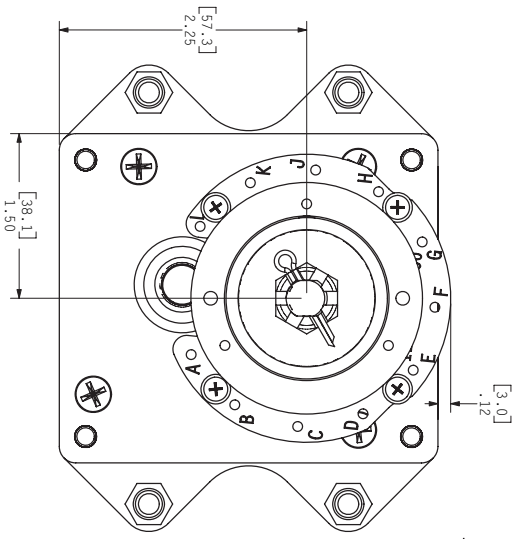

BRACKET CUT-OUT DIMENSIONS  
SCALE 1:2

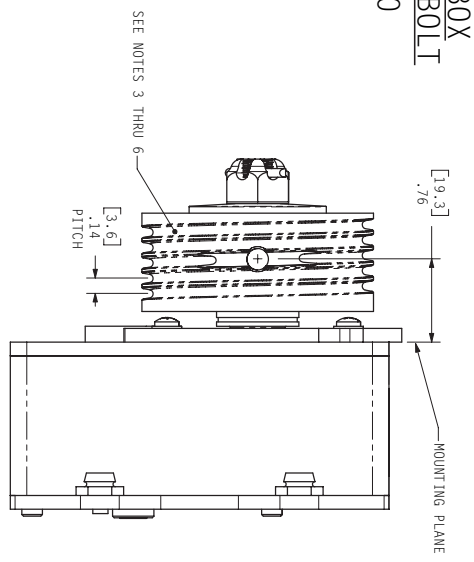
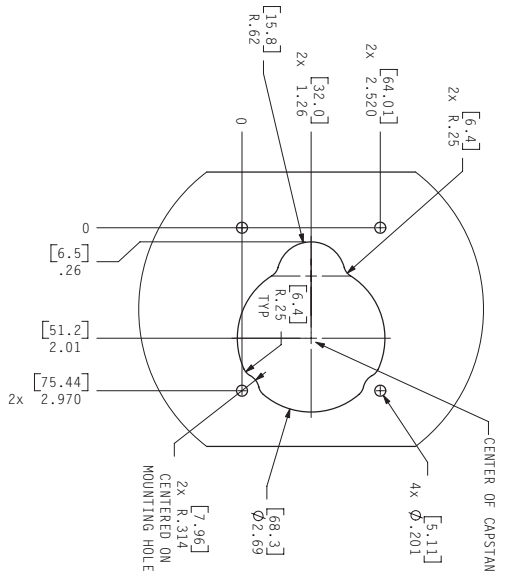
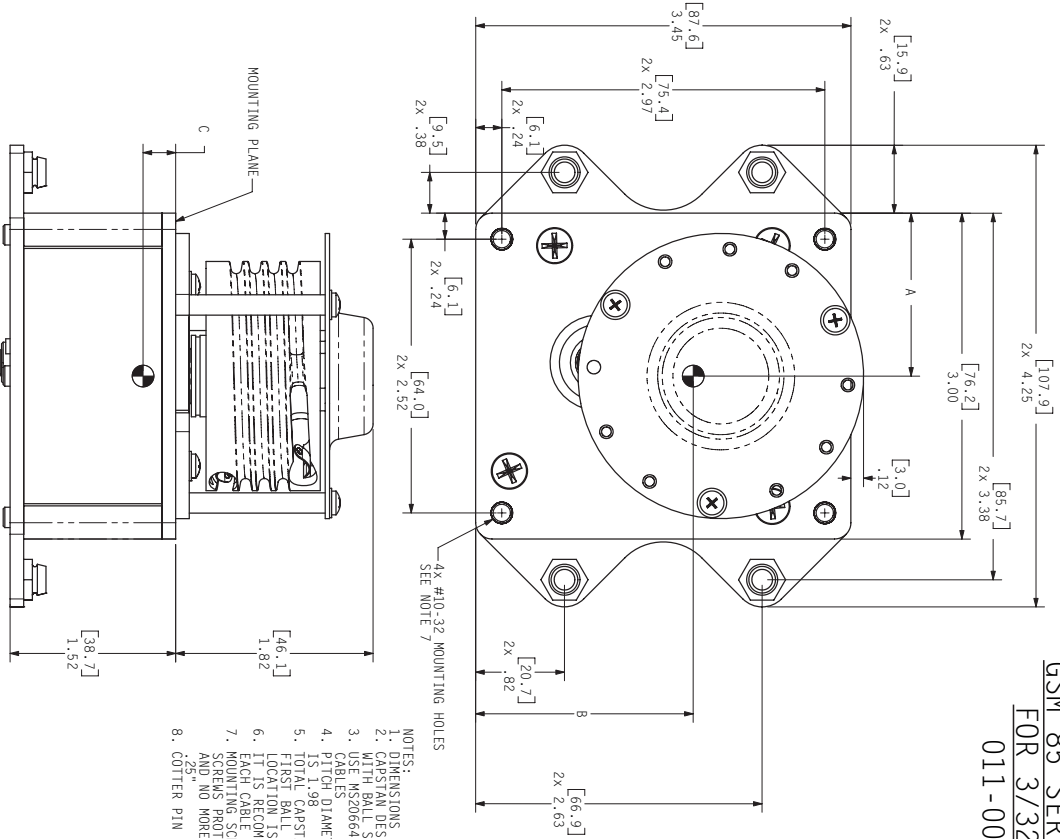

Figure A-5. GSM 85 Servo Gearbox For 1/16" Cable, 4 Bolt (Sheet 2 of 2)

GSM 85 SERVO GEARBOX  
 FOR 3/32" CABLE  
 011-00894-11



- NOTES:
1. DIMENSIONS IN INCHES (mm)
  2. PARTS DESIGNATED FOR END OF EACH WITHIN DESIGNATED SHANK OF EACH CABLES
  3. USE MS20664-3 SINGLE SHANK BALL ON ENDS OF CABLES
  4. PITCH DIAMETER OF CABLE WRAPPED ON CAPSTAN IS 1.98
  5. TOTAL CAPSTAN GROOVE LENGTH FROM CENTER OF FIRST CABLE TO CENTER OF SECOND BALL LOCATION IS 3.14 INCHES + .250 TOLERANCE
  6. IT IS RECOMMENDED THAT AT LEAST 1/4 WRAP OF EACH CABLE REMAINS ON CAPSTAN AT ALL TIMES
  7. MOUNTING SCREW LENGTH SHALL BE SUCH THAT SCREWS PROTRUDE INTO SERVO GEARBOX AT LEAST .25" AND NO MORE THAN .75". RECOMMENDED DEPTH IS .50"
  8. COTTER PIN IS MS24665-283

CAPSTAN COVER, STANDOFFS, SCREWS, AND WASHERS CONTAINED IN 011-01028-00 MOUNTING KIT

THREE OR FOUR STANDOFFS MAY BE PLACED IN VARIOUS POSITIONS TO ACCOMMODATE CABLE PLAY-OFF. PLACE STANDOFFS TO ENSURE PROPER COVER SUPPORT.

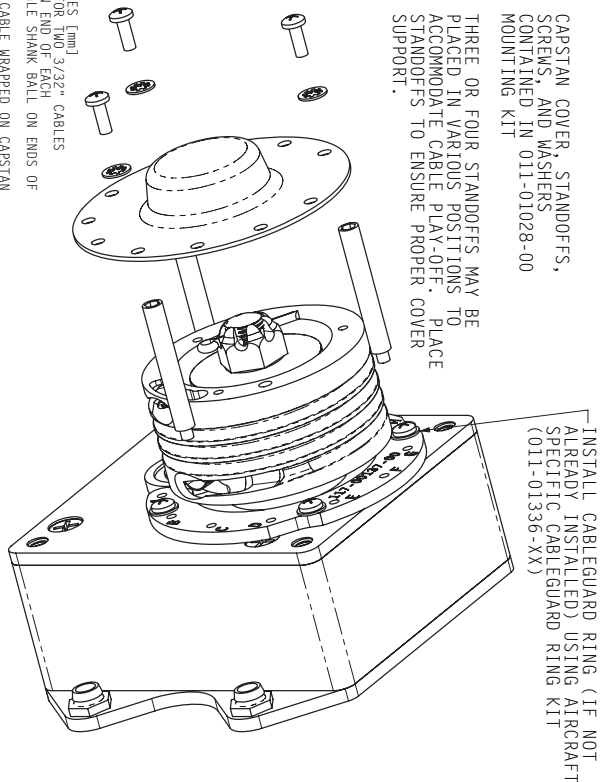

| Center of Gravity Location Dimension | A (in) | B (in) | C (in) |
|--------------------------------------|--------|--------|--------|
|                                      | 1.5    | 2.0    | 0.3    |

Figure A-6. GSM 85 Servo Gearbox For 3/32" Cable (Sheet 1 of 2)

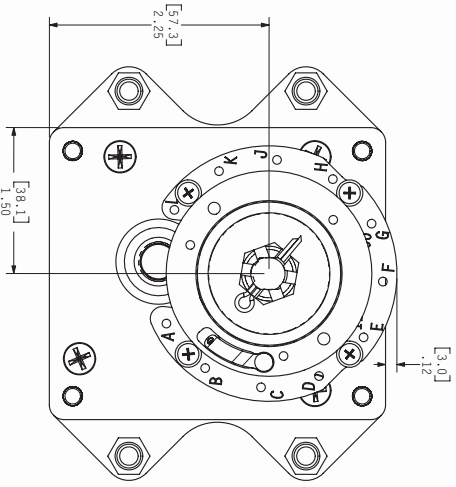

GSM 85 SERVO GEARBOX  
FOR 3/32" CABLE  
011-00894-11

BRACKET CUT-OUT DIMENSIONS  
SCALE 1:2

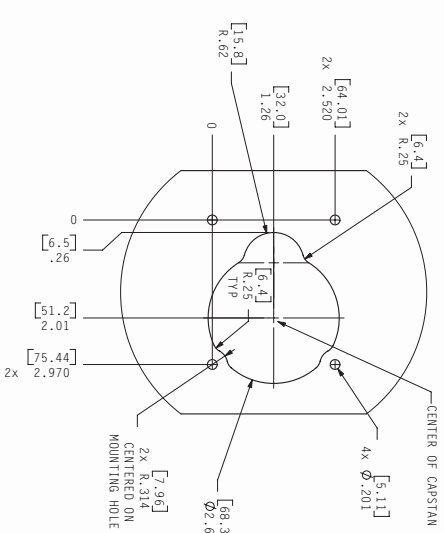

THESE ARE SHOWN AS EXAMPLES OF CABLES WRAPPED ON CAPSTANS. CABLE 1 HAVING 1/2 TURN OF CABLE LEFT ON THE CAPSTAN. IT IS RECOMMENDED THAT NO LESS THAN 1/4 TURN OF EACH CABLE REMAIN ON CAPSTAN AT ALL TIMES.

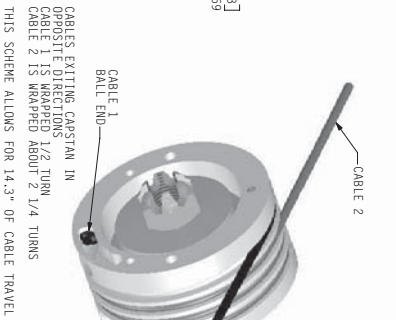

CABLES EXITING CAPSTAN IN OPPOSITE DIRECTIONS  
CABLE 1 IS WRAPPED ABOUT 1/2 TURN  
CABLE 2 IS WRAPPED ABOUT 1/2 TURN  
THIS SCHEME ALLOWS FOR 14.3" OF CABLE TRAVEL

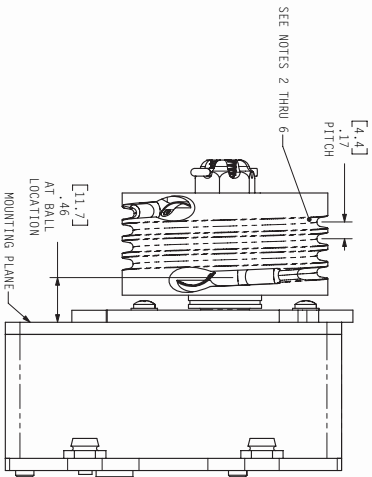

SEE NOTES 2 THRU 6  
PITCH

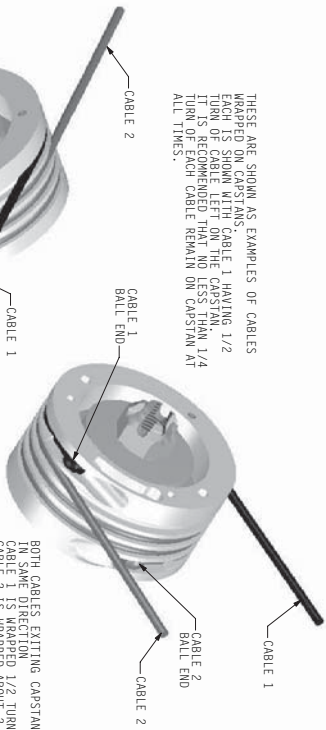

BOTH CABLES EXITING CAPSTAN IN SAME DIRECTION  
CABLE 1 IS WRAPPED ABOUT 1/2 TURN  
CABLE 2 IS WRAPPED ABOUT 3/4 TURN  
THIS SCHEME ALLOWS FOR 17.4" OF CABLE TRAVEL

BALL SHANK SHALL BE INSTALLED ON CABLE AS SHOWN ABOVE. SEE NOTE 3.

Figure A-6. GSM 85 Servo Gearbox For 3/32" Cable (Sheet 2 of 2)

**GSM 85 SERVO GEARBOX,  
CONTINUOUS TRAVEL**  
011-00894-02

CAPSTAN COVER, STANDOFFS, SCREWS, AND WASHERS CONTAINED IN 011-01028-01 MOUNTING KIT. FIVE STANDOFFS SHOULD BE USED AS SHOWN.

ALL CABLEGUARD CAPSTAN COVER SCREWS AND STANDOFFS SHOULD BE TIGHTENED TO 10 +/- 2 IN-LBS

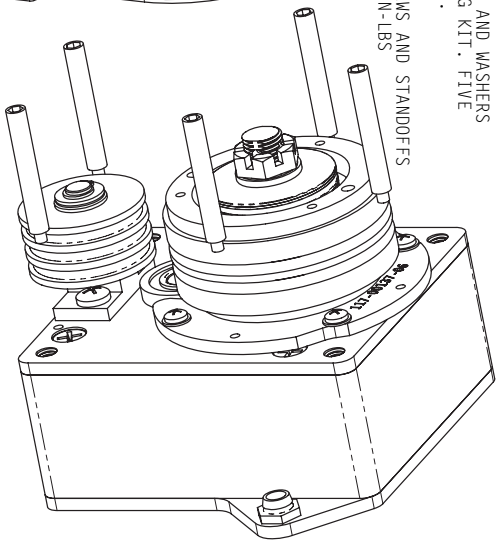
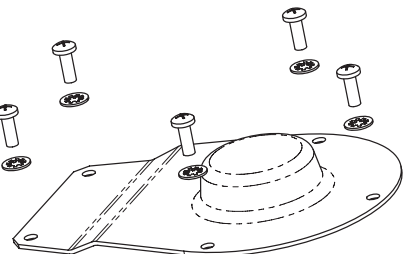
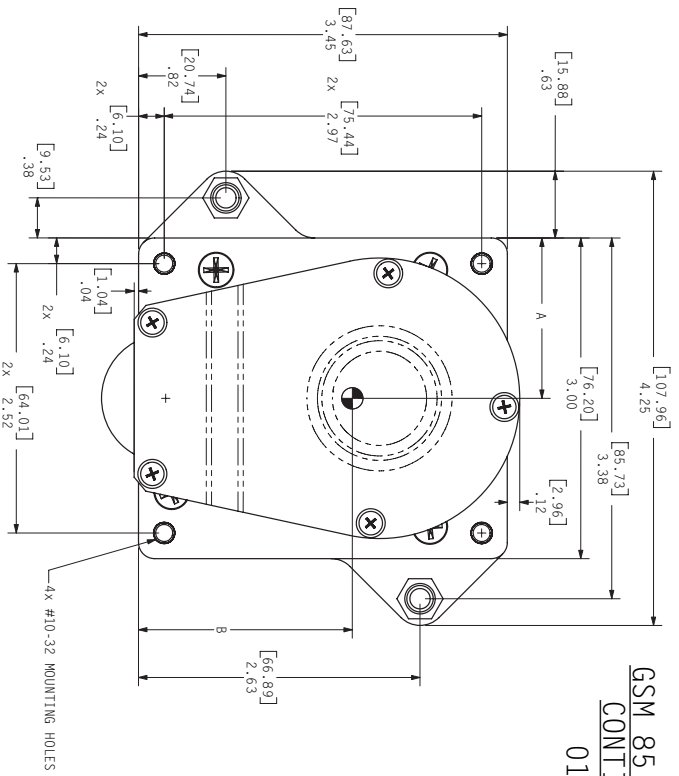

- NOTES:
1. DIMENSIONS IN INCHES [mm]
  2. MOUNTING SCREW LENGTH SHALL BE SUCH THAT SCREWS PROTRUDE INTO SERVO GEARBOX AT LEAST 0.125 INCHES [3.175 mm]
  3. CAPSTAN DESIGNED FOR 1716" CABLE RECOMMENDED DEPTH IS .25"
  4. PITCH DIAMETER OF CABLE WRAPPED ON IDLER PULLEY IS 1.09
  5. PITCH DIAMETER OF CABLE WRAPPED ON CAPSTAN COTTER PIN IS MS24666-283

| Center of Gravity Location | A (in) | B (in) | C (in) |
|----------------------------|--------|--------|--------|
| Dimension Value (inches)   | 1.5    | 1.8    | 0.2    |

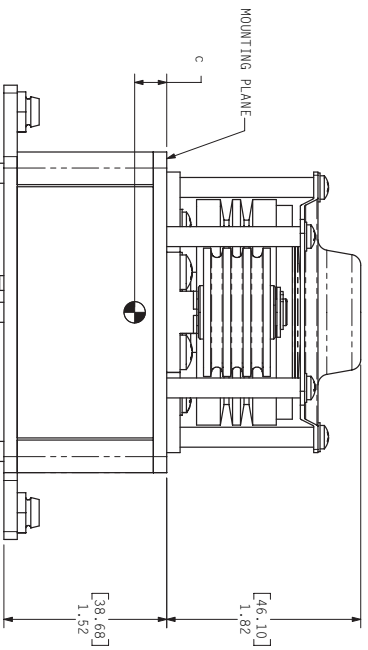

Figure A-7. GSM 85 Servo Gearbox, Continuous Travel (Sheet 1 of 2)

GSM 85 SERVO GEARBOX,  
CONTINUOUS TRAVEL  
011-00894-02

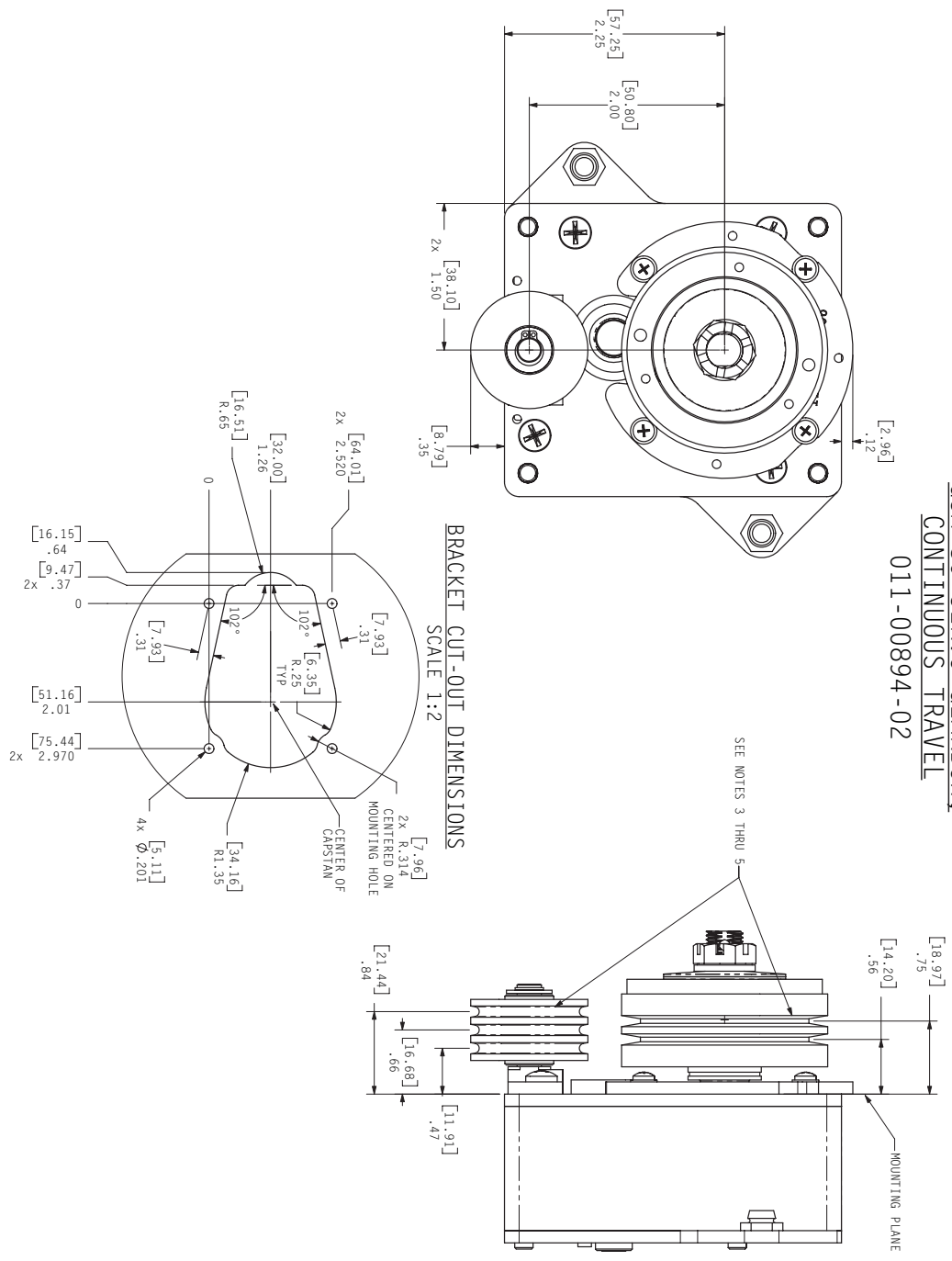

Figure A-7. GSM 85 Servo Gearbox, Continuous Travel (Sheet 2 of 2)

GSM 85 SERVO GEARBOX  
WITH SPROCKET  
011-00894-04

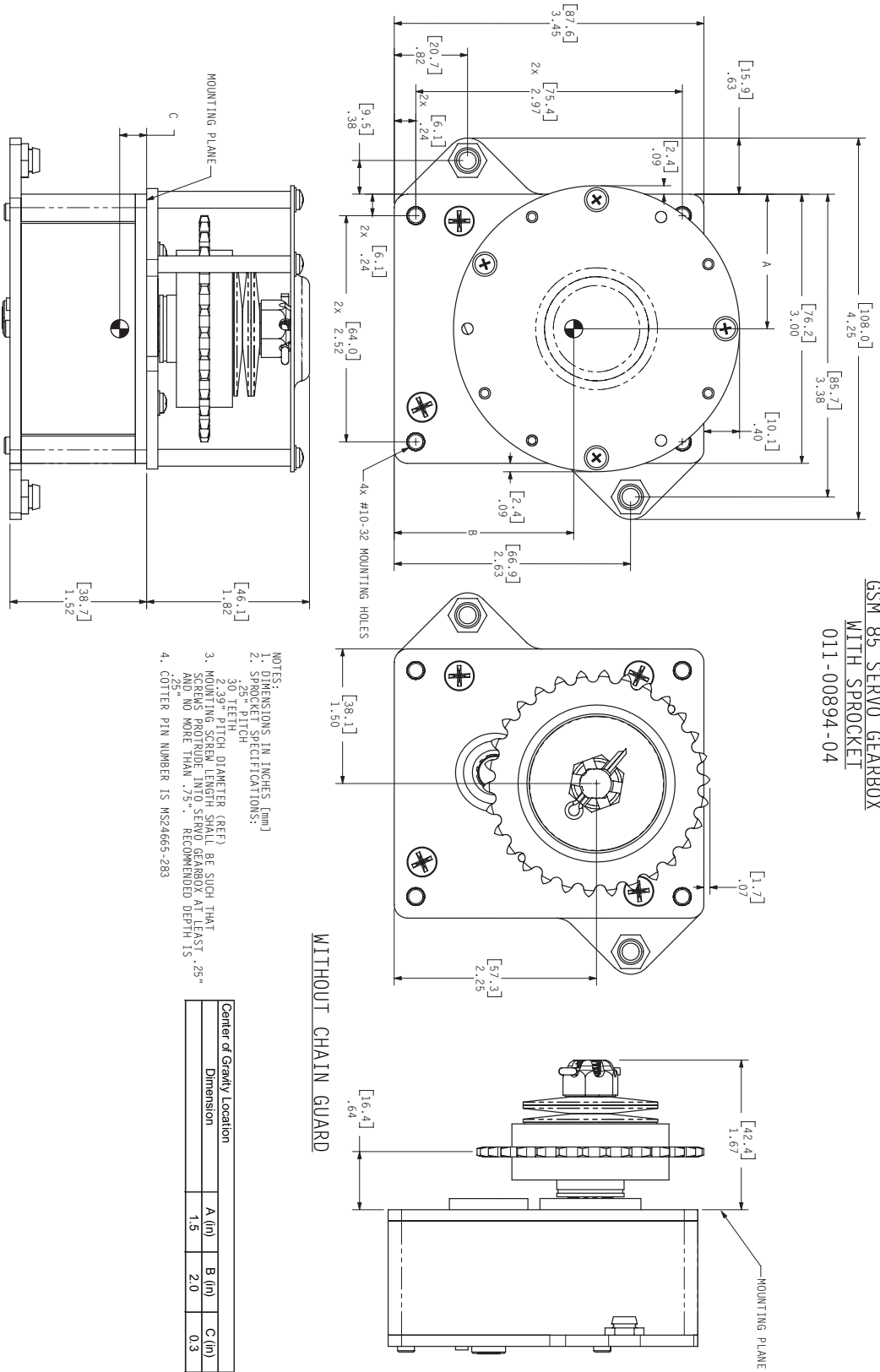

Figure A-8. GSM 85 Servo Gearbox With Sprocket (Sheet 1 of 2)

CAPSTAN COVER, STANDOFFS, GUARD  
BASE, SCREWS, AND WASHERS CONTAINED  
IN 011-01028-02 MOUNTING KIT

ALL CHAINGUARD RING SCREWS, CAPSTAN  
COVER SCREWS, AND STANDOFFS SHOULD  
BE TIGHTENED TO 10 +/- 2 IN-LBS.

GSM 85 SERVO GEARBOX  
WITH SPROCKET

011-00894-04

INSTALL CHAINGUARD RING (IF NOT ALREADY  
INSTALLED) USING AIRCRAFT SPECIFIC  
CHAINGUARD RING KIT (011-01375-XX)

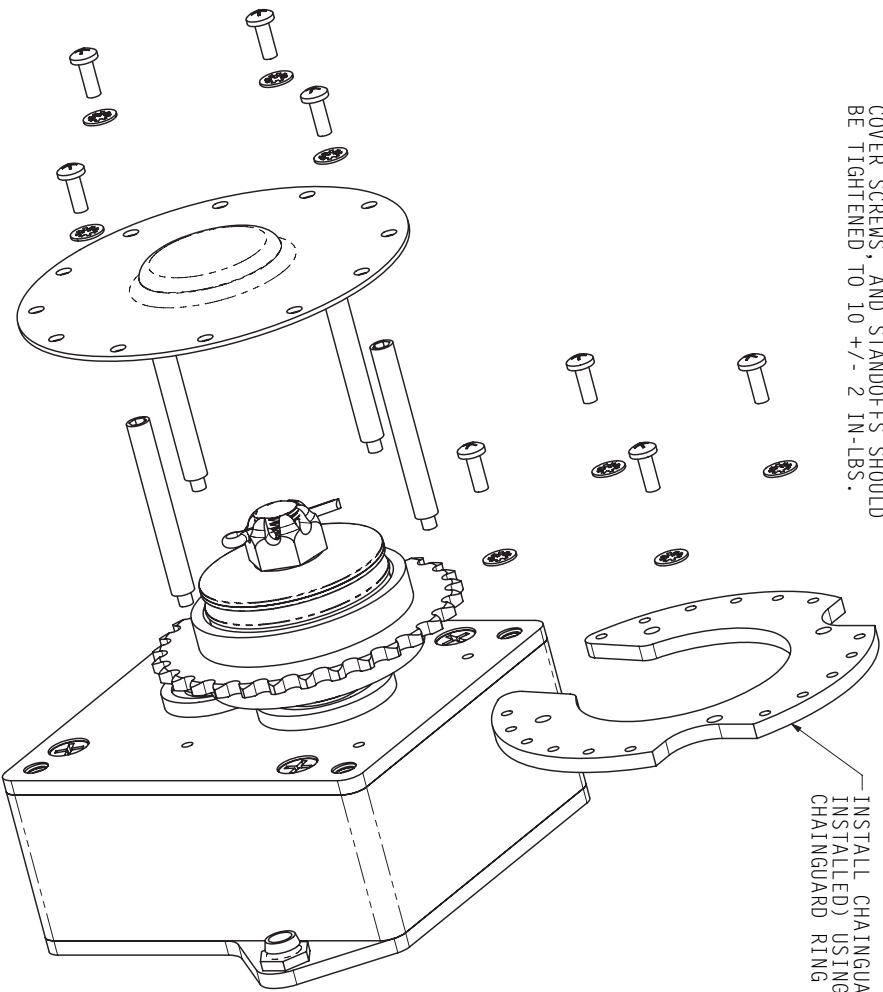

BRACKET CUT-OUT DIMENSIONS  
SCALE 1:2

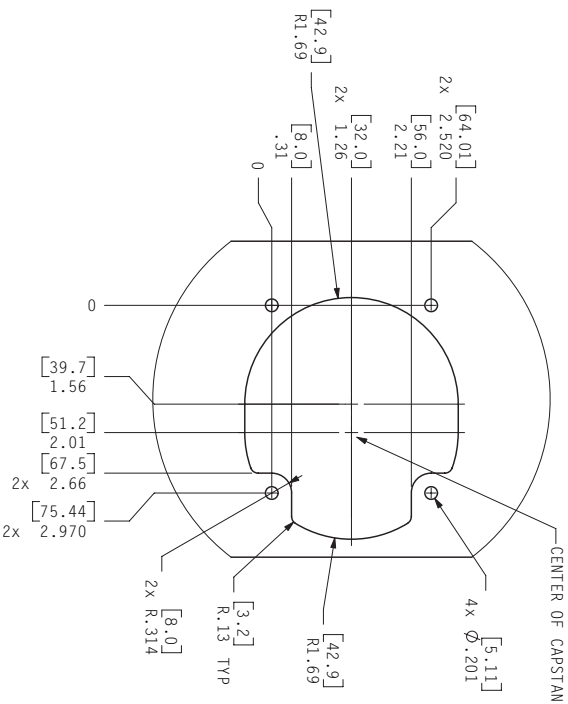
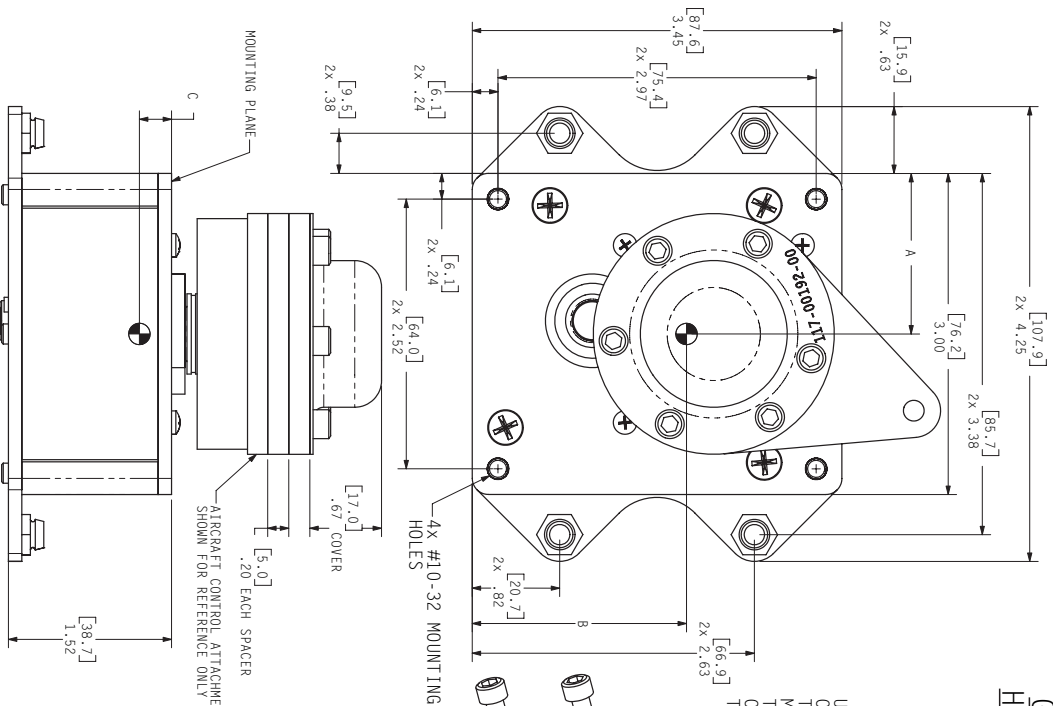

Figure A-8. GSM 85 Servo Gearbox With Sprocket (Sheet 2 of 2)

GSM 85 UNIVERSAL  
HUB SERVO GEARBOX  
011-00894-09



AIRCRAFT CONTROL ATTACHMENT SHOWN FOR REFERENCE ONLY. SEE NOTE 3.

USE ONE SPACER IF AIRCRAFT CONTROL ATTACHMENT IS LESS THAN 0.50" BUT EQUAL TO OR MORE THAN 0.30" THICK. USE TWO SPACERS IF AIRCRAFT CONTROL ATTACHMENT IS LESS THAN 0.30" THICK. SEE NOTE 3.

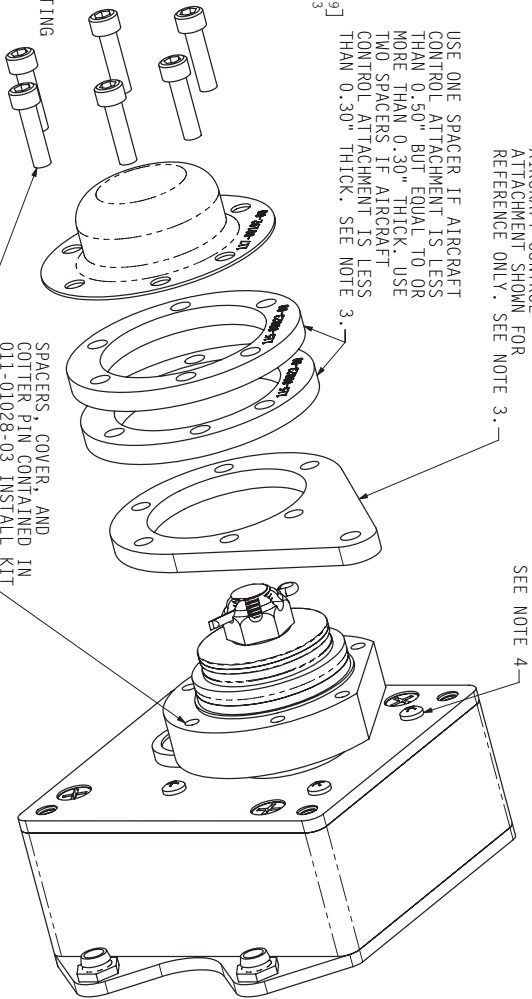

NOTES:

1. DIMENSIONS IN INCHES [mm]
2. MOUNTING SCREW LENGTH SHALL BE SUCH THAT SCREWS PROTRUDE INTO SERVO GEARBOX .25" MINIMUM AND .75" MAXIMUM. RECOMMENDED DEPTH IS .25". DETERMINE ACTUAL HUB SERVO AIRCRAFT ATTACHMENT INSTALLED ON INSTRUCTIONS PROVIDED.
3. HUB SERVO AIRCRAFT ATTACHMENT SHOULD BE INSTALLED ON HUB SERVO AIRCRAFT ATTACHMENT HUB SCREWS SHOULD EXTEND INTO MOUNTING HUB .15" MINIMUM TO .25" MAXIMUM. RECOMMENDED DEPTH IS .25".
4. FOUR #4-40 PAN HEAD SCREWS MAY BE REMOVED AS NECESSARY TO ACCOMMODATE NONSTANDARD MOUNTING BRACKETS. HOWEVER, ANY HOLES WHICH SCREWS ARE REMOVED FROM MUST BE COMPLETELY COVERED BY MOUNTING BRACKET. SCREWS ARE FOR FILLING HOLES ONLY, NOT TO BE USED FOR UNIT MOUNTING PROTRUSIONS.

| Center of Gravity Location           |        |        |  |
|--------------------------------------|--------|--------|--|
| A (in)                               | B (in) | C (in) |  |
| 1.5                                  | 2.0    | 0.3    |  |
| Excludes aircraft control attachment |        |        |  |

Figure A-9. GSM 85 Universal Hub Servo Gearbox (Sheet 1 of 2)



GSM 85 UNIVERSAL  
HUB SERVO GEARBOX  
011-00894-09

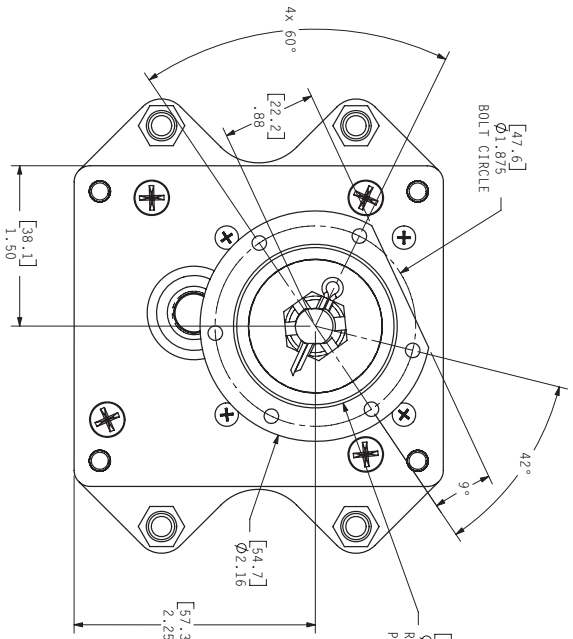

HUB LOCATION AND DIMENSIONS

STANDARD BRACKET  
CUT-OUT DIMENSIONS  
SCALE 1:2

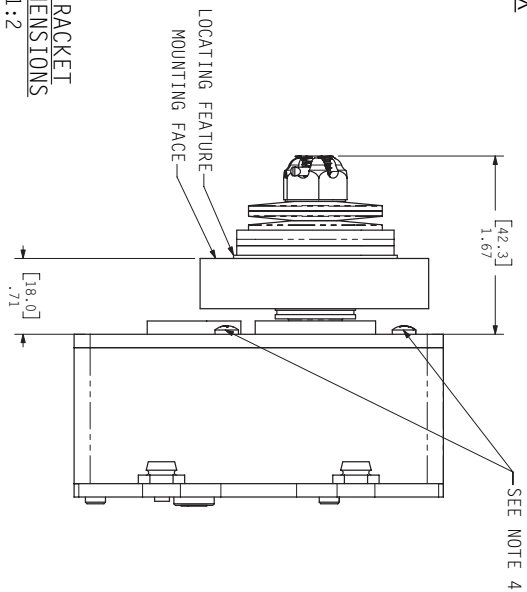
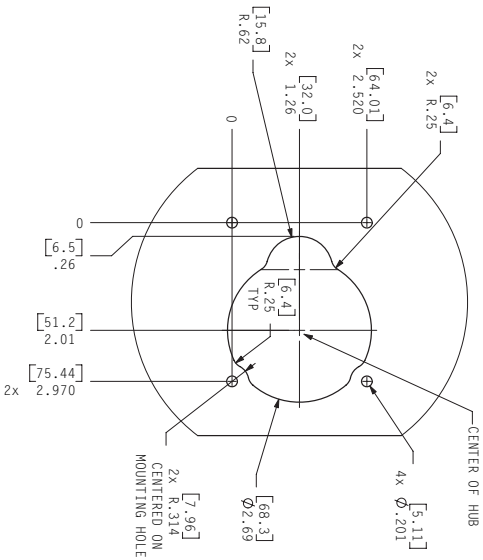
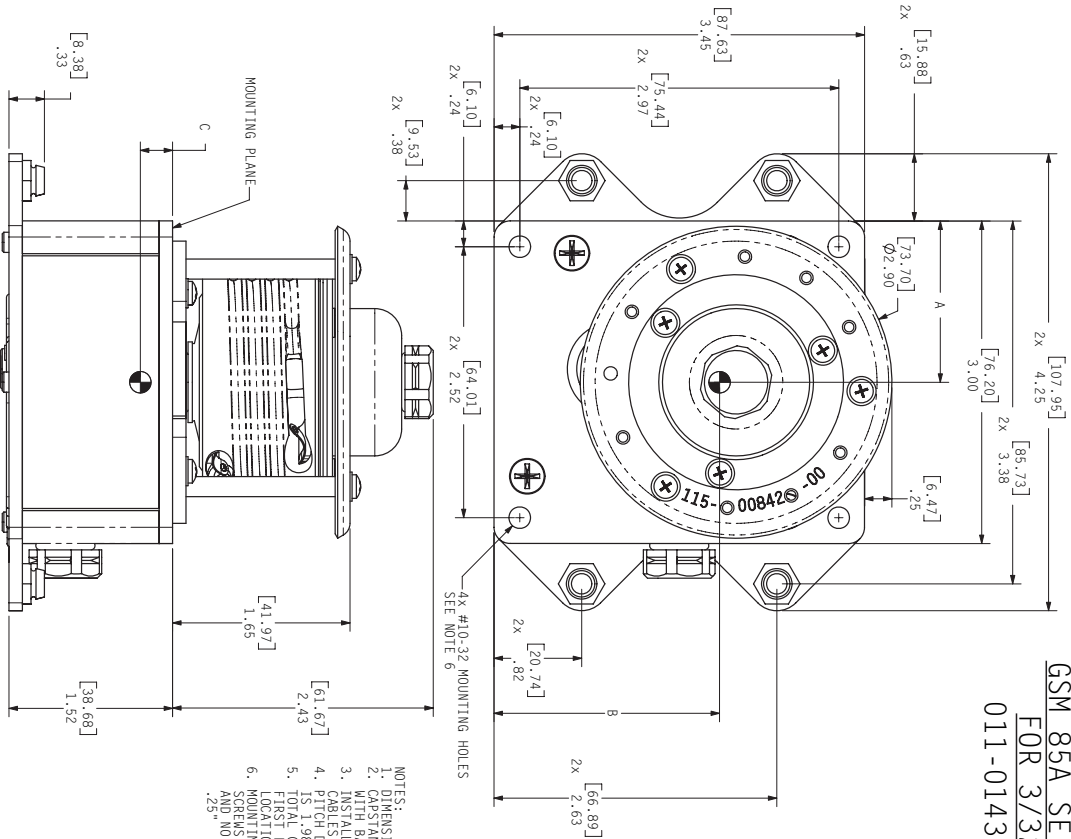
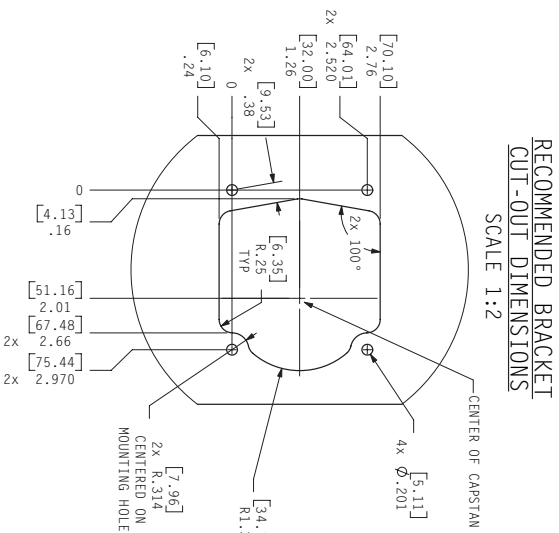

Figure A-9. GSM 85 Universal Hub Servo Gearbox (Sheet 2 of 2)

GSM 85A SERVO GEARBOX  
 FOR 3/32" CABLE  
 011-01436-00, -01



- NOTES:
1. DIMENSIONS IN INCHES (mm)
  2. CAPSTAN DESIGNED FOR TWO 3/32" CABLES WITH BALL SHANK ON END OF EACH
  3. INSTALL MS20664-3 SINGLE SHANK BALL ON ENDS OF CABLES PER MS206646
  4. TOTAL DIAMETER OF CABLE WRAPPED ON CAPSTAN
  5. TOTAL CAPSTAN GROOVE LENGTH FROM CENTER OF FIRST BALL LOCATION TO CENTER OF SECOND BALL LOCATION IS 3 TURNS + 290°
  6. MOUNTING SCREW LENGTH SHALL BE SUCH THAT SCREWS PROTRUDE INTO SERVO GEARBOX AT LEAST .25" AND MORE THAN .75" RECOMMENDED DEPTH IS .25"



RECOMMENDED BRACKET  
 CUT-OUT DIMENSIONS  
 SCALE 1:2

| Center of Gravity Location |        |        |
|----------------------------|--------|--------|
| A (in)                     | B (in) | C (in) |
| 1.5                        | 2.0    | 0.3    |

Figure A-10. GSM 85A Servo Gearbox For 3/32" Cable (Sheet 1 of 2)

GSM 85A SERVO GEARBOX  
FOR 3/32" CABLE  
011-01436-00, -01

COVER AND STANDOFF ASSEMBLY VIEWS  
SCALE 1:1.5

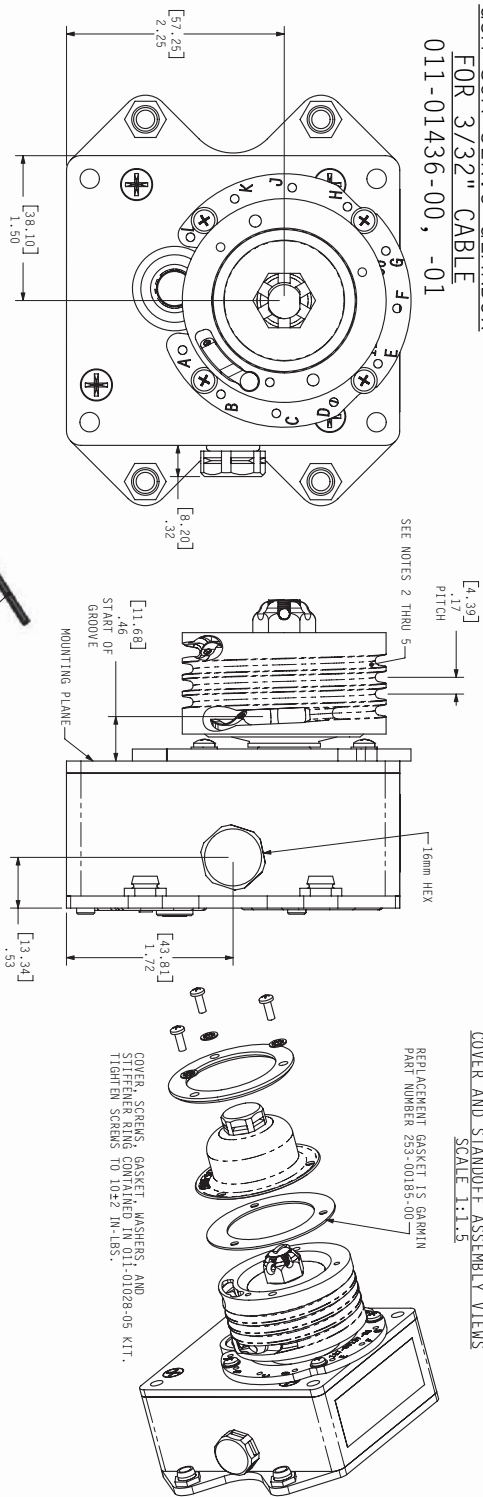

THESE ARE SHOWN AS EXAMPLES OF CABLES WRAPPED ON CAPSTANS. CABLE 1 HAVING 1/2 TURN OF CABLE LEFT ON THE CAPSTAN. IT IS RECOMMENDED THAT NO LESS THAN 1/4 TURN OF EACH CABLE REMAIN ON CAPSTAN AT ALL TIMES.

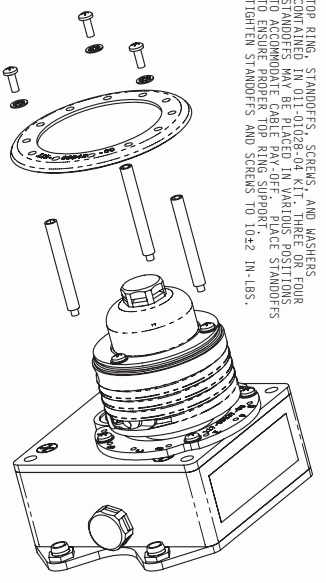
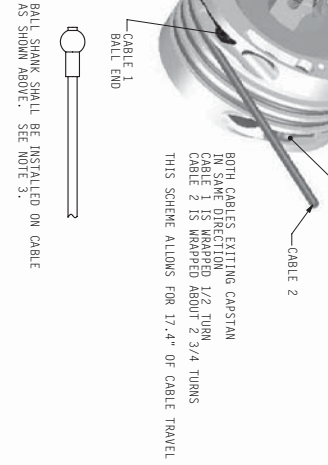
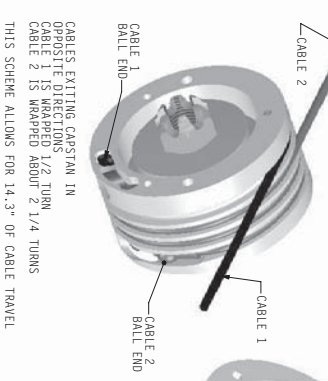
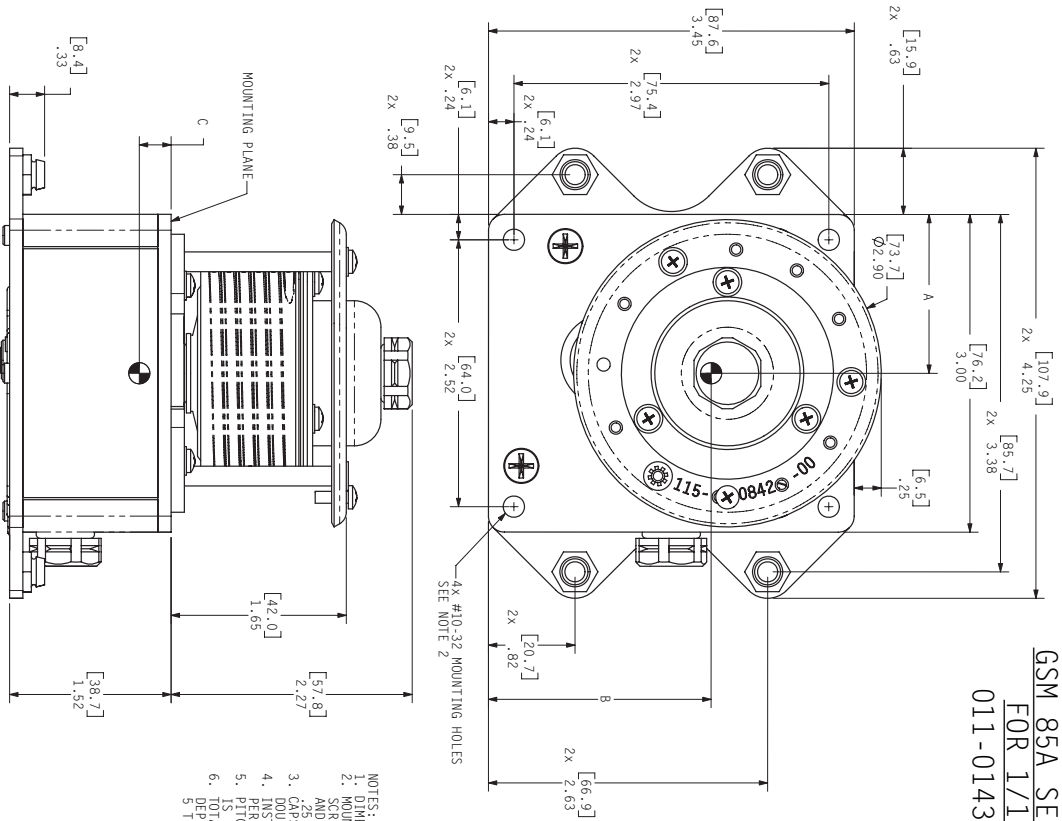

Figure A-10. GSM 85A Servo Gearbox For 3/32" Cable (Sheet 2 of 2)

GSM 85A SERVO GEARBOX  
 FOR 1/16" CABLE  
 011-01436-02, -03



NOTES:  
 1. DIMENSIONS IN INCHES [mm]  
 2. MOUNTING SCREW LENGTH SHALL BE SUCH THAT SCREWS PROTRUDE INTO SERVO GEARBOX AT LEAST .25" AND NO MORE THAN .75". RECOMMENDED DEPTH IS .50"  
 3. CAPSTAN DESIGNED FOR 1/16" CABLE WITH DOUBLE SHANK BALL  
 4. INSTALL MS20663-2 DOUBLE SHANK BALL ON CABLE PER MS20663F  
 5. PITCH DIAMETER OF CABLE WRAPPED ON CAPSTAN SHALL BE .005" TYP  
 6. TOTAL CAPSTAN GROOVE LENGTH FROM END OF FULL DEPTH GROOVE TO END OF FULL DEPTH GROOVE IS 1.52"  
 7. TOTAL CAPSTAN GROOVE LENGTH FROM END OF FULL DEPTH GROOVE TO END OF FULL DEPTH GROOVE IS 1.52"  
 8. TOTAL CAPSTAN GROOVE LENGTH FROM END OF FULL DEPTH GROOVE TO END OF FULL DEPTH GROOVE IS 1.52"

RECOMMENDED BRACKET  
 CUT-OUT DIMENSIONS

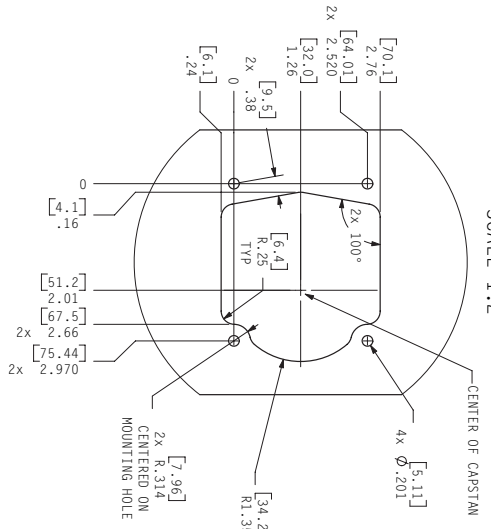

| Center of Gravity Location |        |        |
|----------------------------|--------|--------|
| A (in)                     | B (in) | C (in) |
| 1.5                        | 2.0    | 0.3    |

Figure A-11. GSM 85A Servo Gearbox For 1/16" Cable (Sheet 1 of 2)

GSM 85A SERVO GEARBOX  
FOR 1/16" CABLE  
011-01436-02, -03

COVER AND STANDOFF ASSEMBLY VIEWS  
SCALE 1:1.5

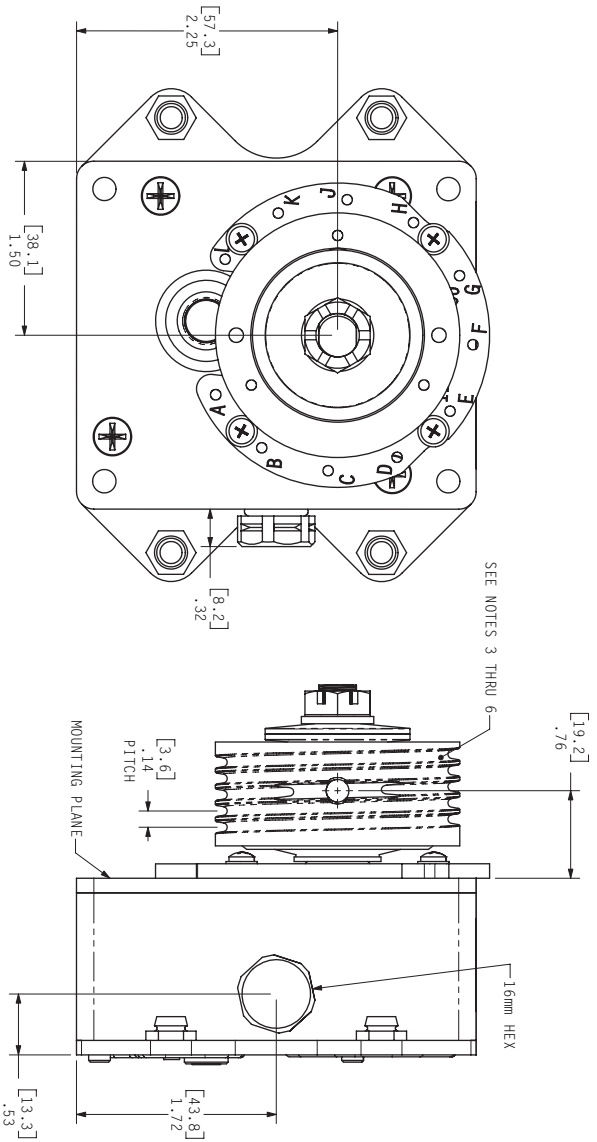

REPLACEMENT GASKET IS GARMIN  
PART NUMBER 253-00185-00

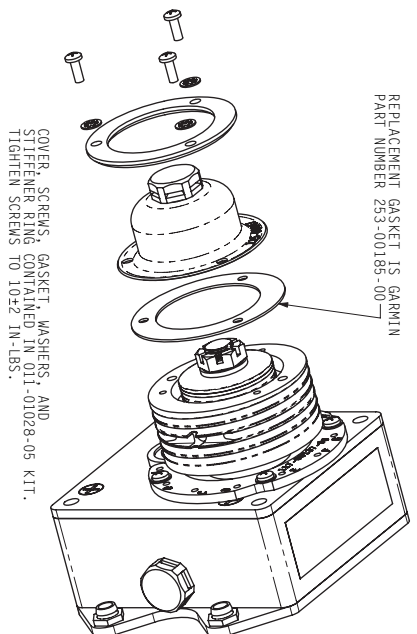

TOP RING, STANDOFFS, SCREWS, AND WASHERS  
CONTAINED IN 011-01028-05 KIT. THREE OR  
STANDOFFS MAY BE PLACED IN VARIOUS POSITIONS  
TO ACCOMMODATE CABLE PAY-OFF. PLACE STANDOFFS  
TO ENSURE PROPER TOP RING SUPPORT.  
TIGHTEN STANDOFFS AND SCREWS TO 10±2 IN-LBS.

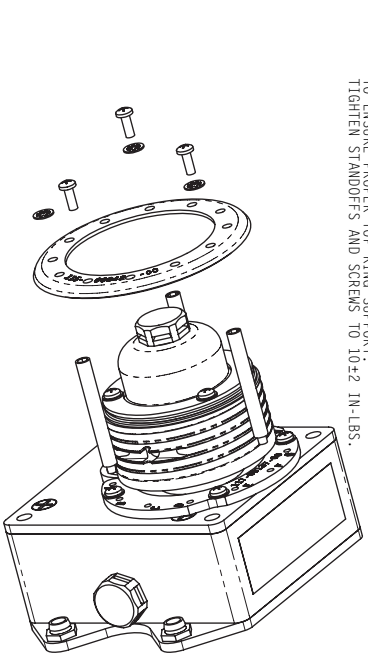

Figure A-11. GSM 85A Servo Gearbox For 1/16" Cable (Sheet 2 of 2)

GSM 85A SERVO GEARBOX  
WITH UNIVERSAL HUB  
011-01436-04, -05, -06

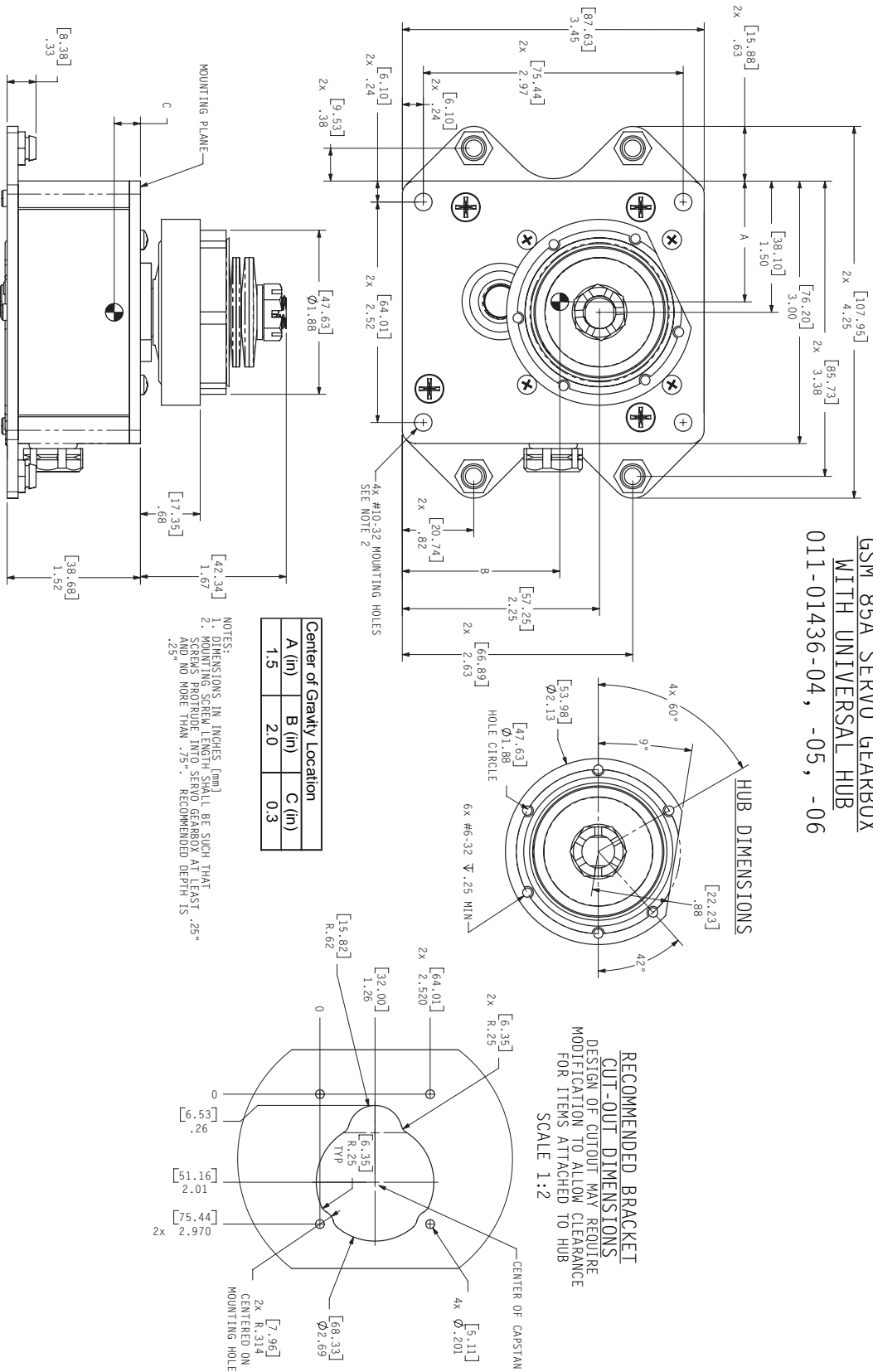
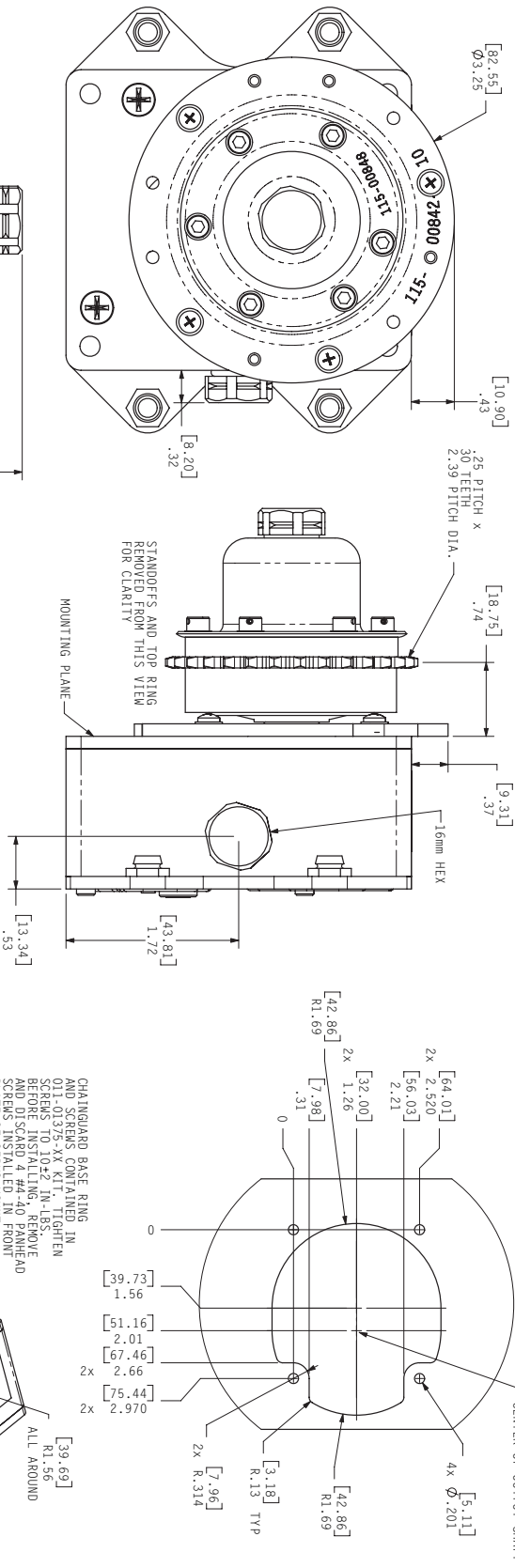

Figure A-12. GSM 85A Servo Gearbox With Universal Hub (Sheet 1 of 3)

GSM 85A SERVO GEARBOX  
WITH UNIVERSAL HUB,  
OPTIONAL SPROCKET ATTACHMENT

RECOMMENDED BRACKET CUT-OUT DIMENSIONS  
SCALE 1:2



PARTS SHOWN HERE ARE CONTAINED IN 011-01028-07 KIT. THREE OR FOUR STANDOFFS MAY BE PLACED IN VARIOUS POSITIONS TO ACCOMMODATE CHAIN PAY-OFF ANGLES. PLACE STANDOFFS TO ENSURE PROPER TOP RING SUPPORT. TIGHTEN STANDOFFS AND SCREWS TO 10±2 IN.-LBS.

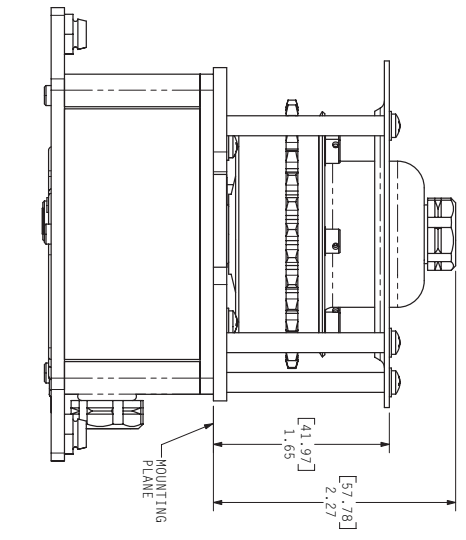
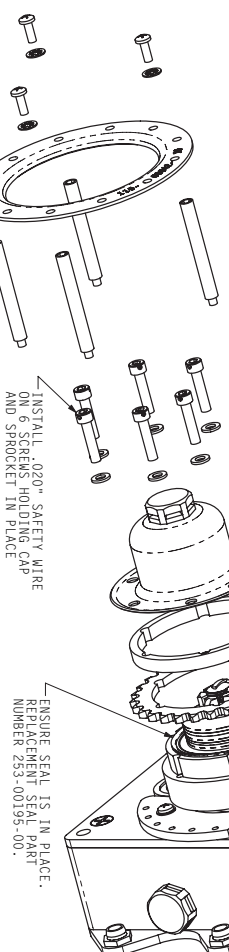

Figure A-12. GSM 85A Servo Gearbox With Universal Hub, Optional Sprocket Attachment (Sheet 2 of 3)

GSM 85A SERVO GEARBOX  
WITH UNIVERSAL HUB,  
GENERIC ATTACHMENT

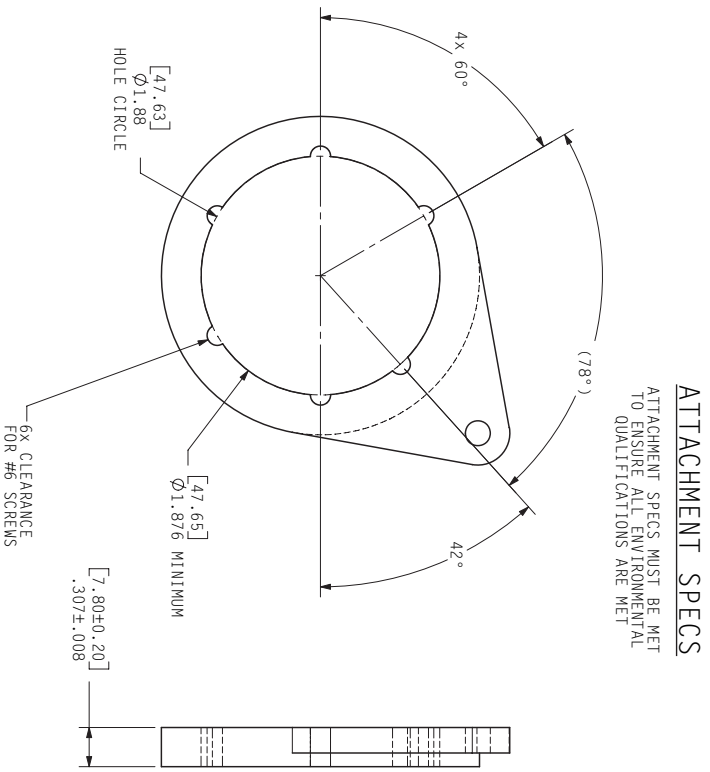
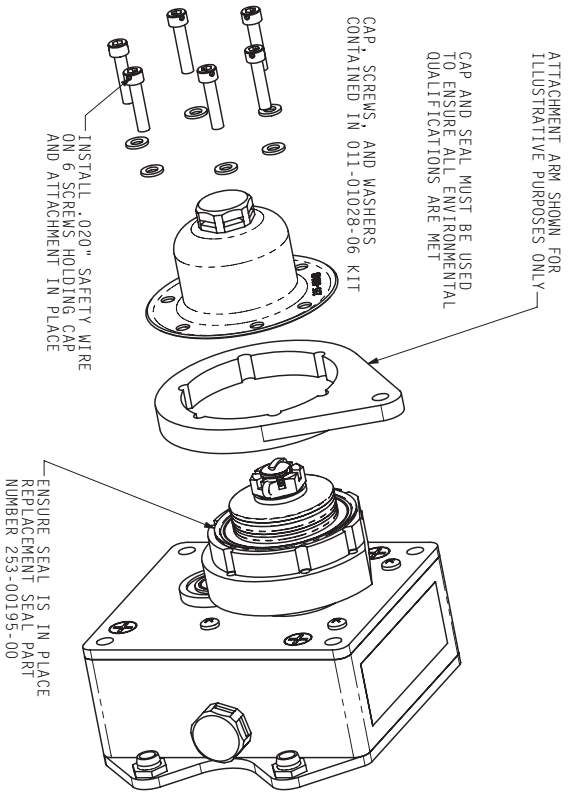
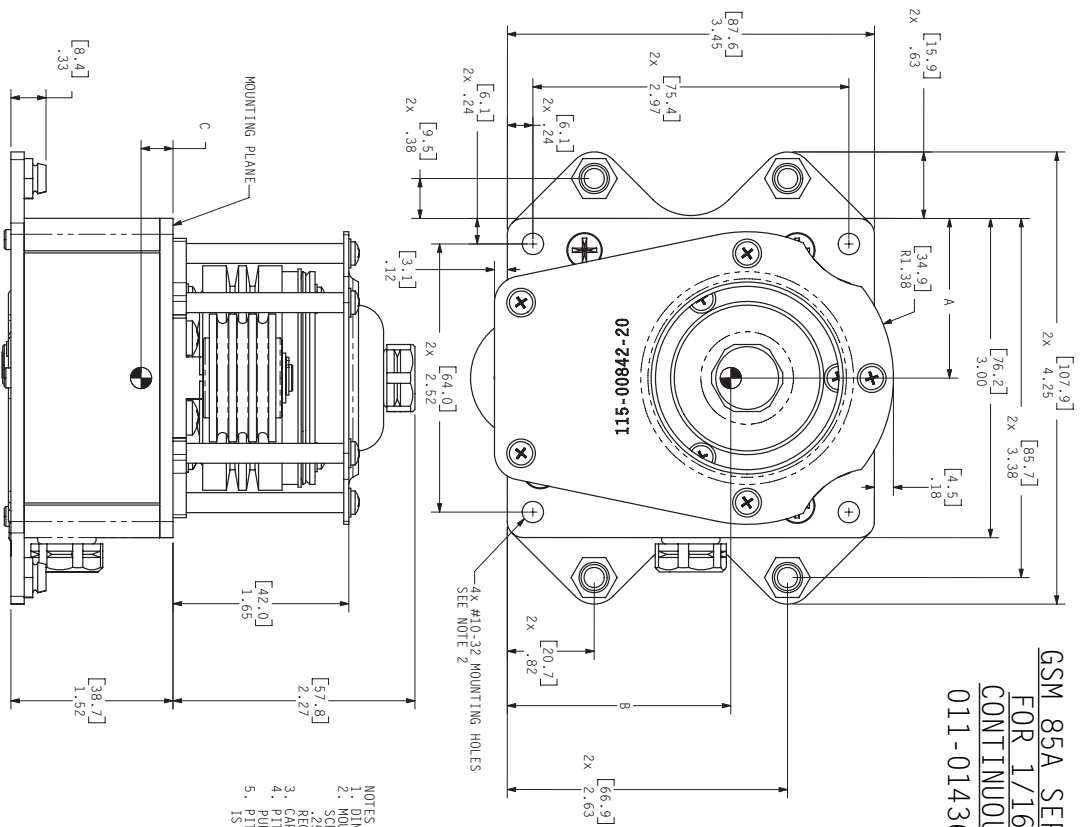

Figure A-12. GSM 85A Servo Gearbox With Universal Hub, Generic Attachment (Sheet 3 of 3)



GSM 85A SERVO GEARBOX  
FOR 1/16" CABLE,  
CONTINUOUS TRAVEL  
011-01436-07, -08



- NOTES:
1. DIMENSIONS IN INCHES [mm]
  2. MOUNTING SCREW LENGTH SHALL BE SUCH THAT SCREWS PROTRUDE INTO SERVO GEARBOX AT LEAST .25" (6.35mm) AND NO MORE THAN .75" (19.05mm)
  3. CAPSTAN DESIGNED FOR 1/16" CABLE
  4. PITCH DIAMETER OF CABLE WRAPPED ON CAPSTAN IS 1.09
  5. PITCH DIAMETER OF CABLE WRAPPED ON CAPSTAN IS 1.82

RECOMMENDED BRACKET  
CUT-OUT DIMENSIONS  
SCALE 1:2

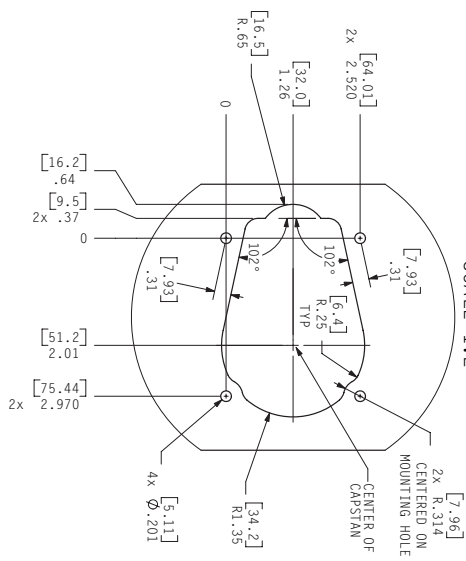

| Center of Gravity Location |        |        |  |
|----------------------------|--------|--------|--|
| A (in)                     | B (in) | C (in) |  |
| 1.5                        | 1.8    | 0.2    |  |

Figure A-13. GSM 85A Servo Gearbox For 1/16" Cable, Continuous Travel (Sheet 1 of 2)

GSM 85A SERVO GEARBOX FOR  
 1/16" CABLE, CONTINUOUS TRAVEL  
 011-01436-07, -08

COVER AND STANDOFF ASSEMBLY VIEWS  
 SCALE: 1:1.5

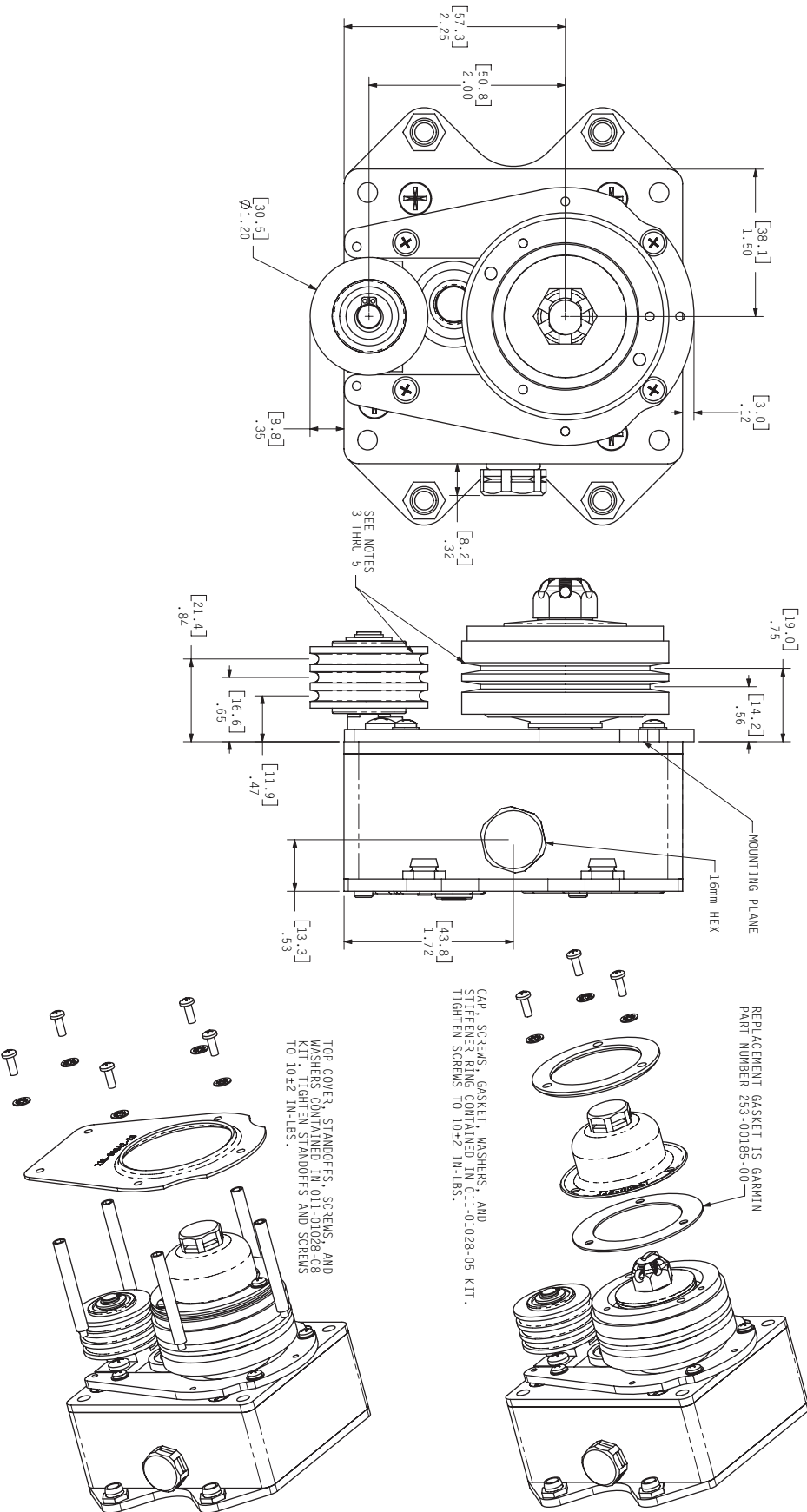

Figure A-13. GSM 85A Servo Gearbox For 1/16" Cable, Continuous Travel (Sheet 2 of 2)

FOR CABLE ENDS EXITING CAPSTAN IN SAME DIRECTION AND ANGLE, FULL WRAPS OF CABLE IS RECOMMENDED AS SHOWN IN A AND B. BALL SHOULD BE IN CENTER OF CABLE WRAP WHEN CABLE IS AT CENTER OF CAPSTAN. EITHER DIRECTION, ROTATE ONE FULL TURN EITHER DIRECTION, ALLOWING MAXIMUM OF 12.4" TRAVEL. THIS LEAVES A MINIMUM OF 4" BETWEEN END OF FULL DEPTH GROOVE AND 1/4 TURN OF CABLE BETWEEN THE END OF FULL DEPTH CAPSTAN GROOVE AND CABLE EXIT 2.

**CABLE WRAP RECOMMENDATIONS AND REQUIREMENTS, 1/16" SPIRAL CAPSTAN**

| GSM 85 AND GSM 85A | 011-01436-02, -03 | 011-00894-00, -07, -08, -10 |
|--------------------|-------------------|-----------------------------|
|--------------------|-------------------|-----------------------------|

FOR CABLE ENDS EXITING CAPSTAN IN OPPOSITE DIRECTION AND ANGLE, FULL WRAPS OF CABLE IS RECOMMENDED AS SHOWN IN C, D, AND E. BALL SHOULD BE IN CENTER OF CABLE WRAP WHEN CABLE IS AT CENTER OF CAPSTAN. EITHER DIRECTION, ROTATE ONE FULL TURN EITHER DIRECTION, ALLOWING MAXIMUM OF 12.4" TRAVEL. THIS LEAVES A MINIMUM OF 1/2" TURN OF CABLE BETWEEN THE END OF FULL DEPTH GROOVE AND CABLE EXIT 4 AT THE END OF THE FULL DEPTH GROOVE.

IT IS RECOMMENDED THAT NO LESS THAN 1/4 TURN OF CABLE REMAIN BETWEEN CABLE EXIT FROM CAPSTAN AND LOCATING BALL. SEE ILLUSTRATION F.

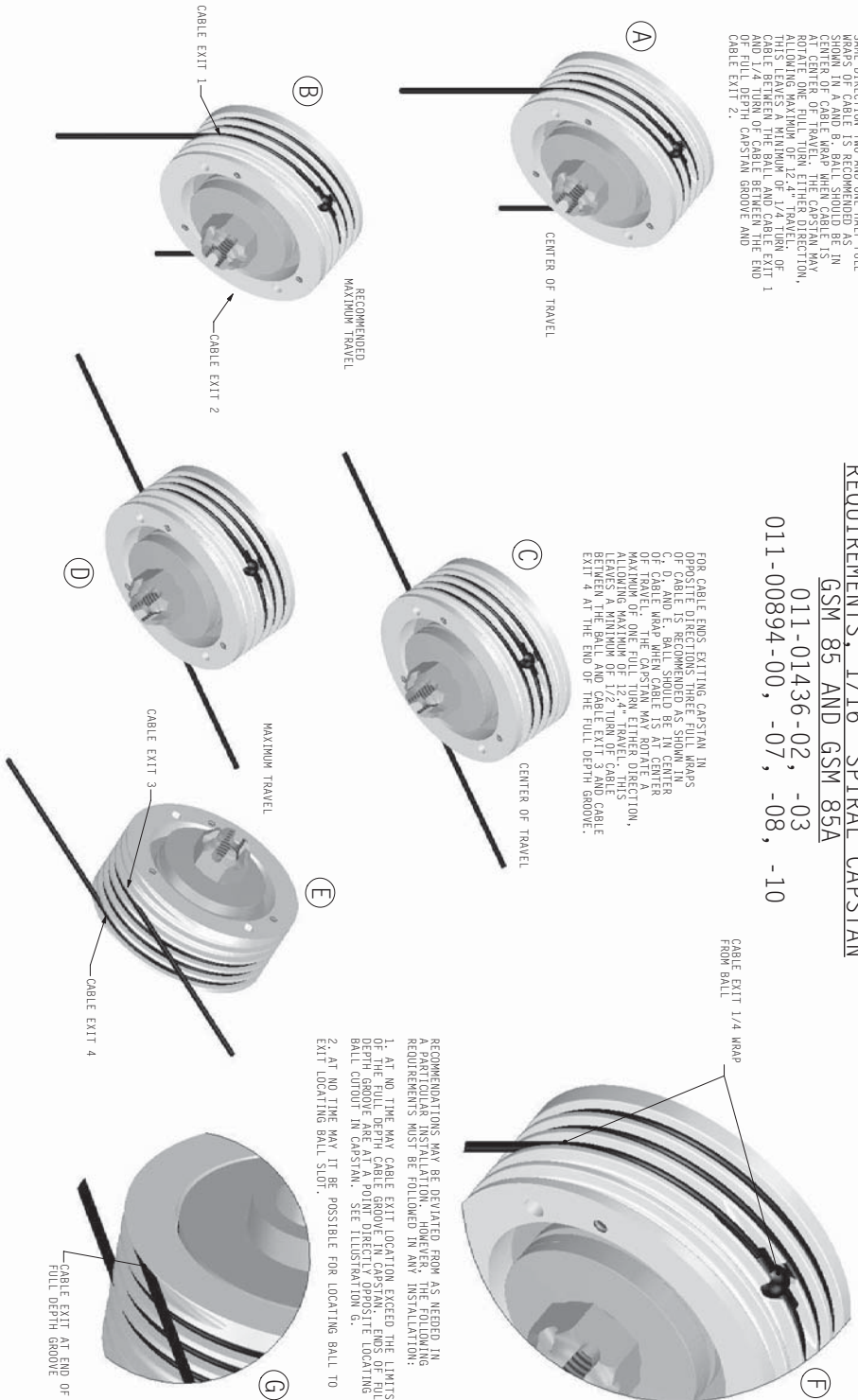

RECOMMENDATIONS MAY BE DEVIATED FROM AS NEEDED IN A PARTICULAR INSTALLATION. HOWEVER, THE FOLLOWING REQUIREMENTS MUST BE FOLLOWED IN ANY INSTALLATION:

1. AT NO TIME MAY CABLE EXIT LOCATION EXCEED THE LIMITS OF THE FULL DEPTH GROOVE IN CAPSTAN. ENDS OF FULL DEPTH GROOVE ARE AT A POINT DIRECTLY OPPOSITE LOCATING BALL CUTOUT IN CAPSTAN. SEE ILLUSTRATION G.
2. AT NO TIME MAY IT BE POSSIBLE FOR LOCATING BALL TO EXIT LOCATING BALL SLOT.

Figure A-14. Cable Wrap Recommendations And Requirements, 1/16" Spiral Capstan GSM 85 And GSM 85A

CABLE WRAP RECOMMENDATIONS FOR  
CONTINUOUS TRAVEL SERVO GEARBOXES  
GSM 85 AND GSM 85A

011-00894-02  
011-01436-07, -08

CABLE EXITS IN OPPOSITE DIRECTIONS

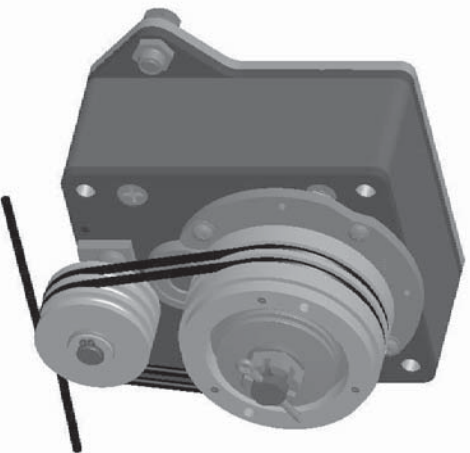

CABLE EXITS IN SAME DIRECTION

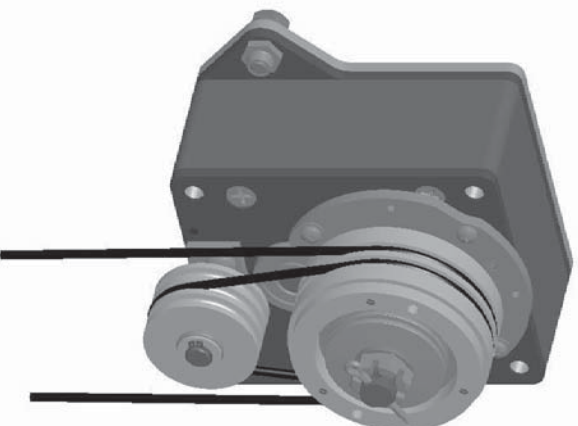

**Figure A-15. Cable Wrap Recommendations For Continuous Travel Servo Gearboxes GSM 85 and GSM 85A**

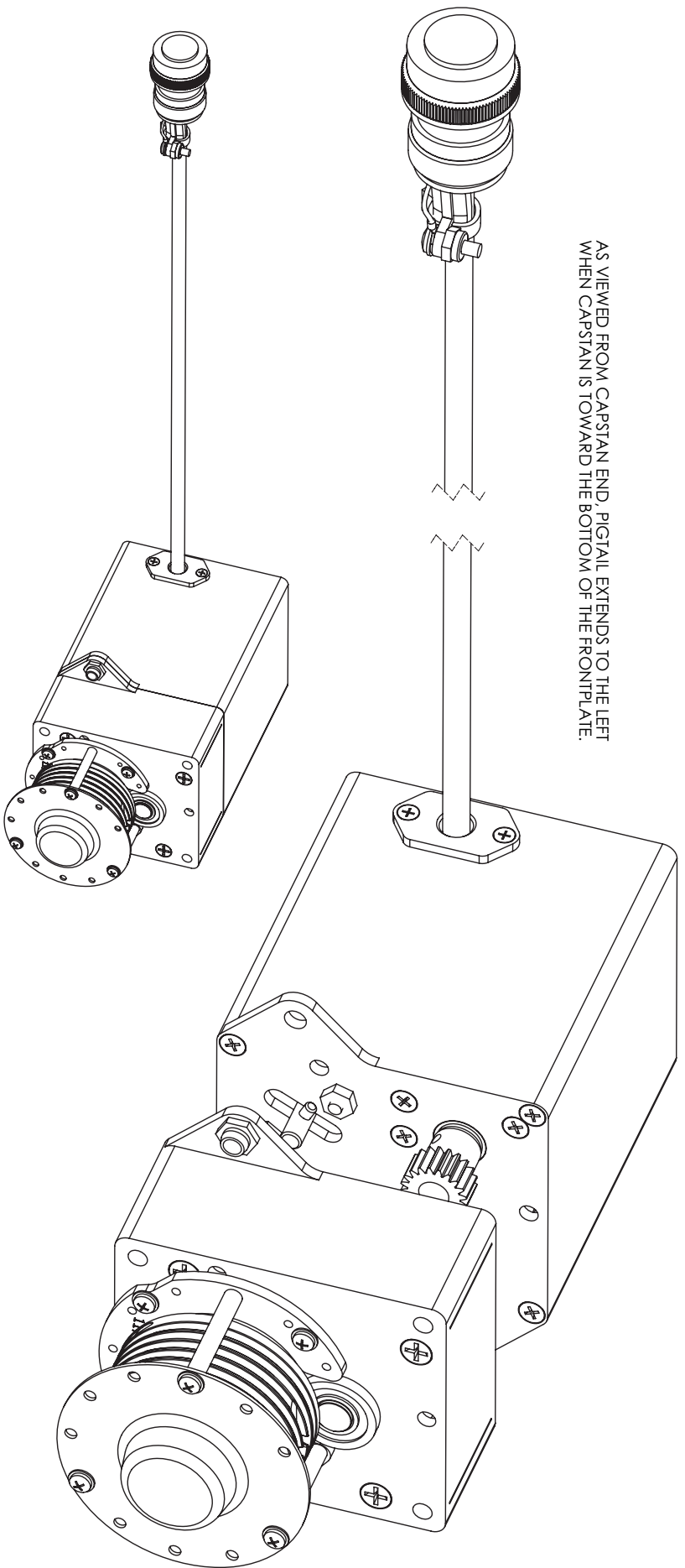
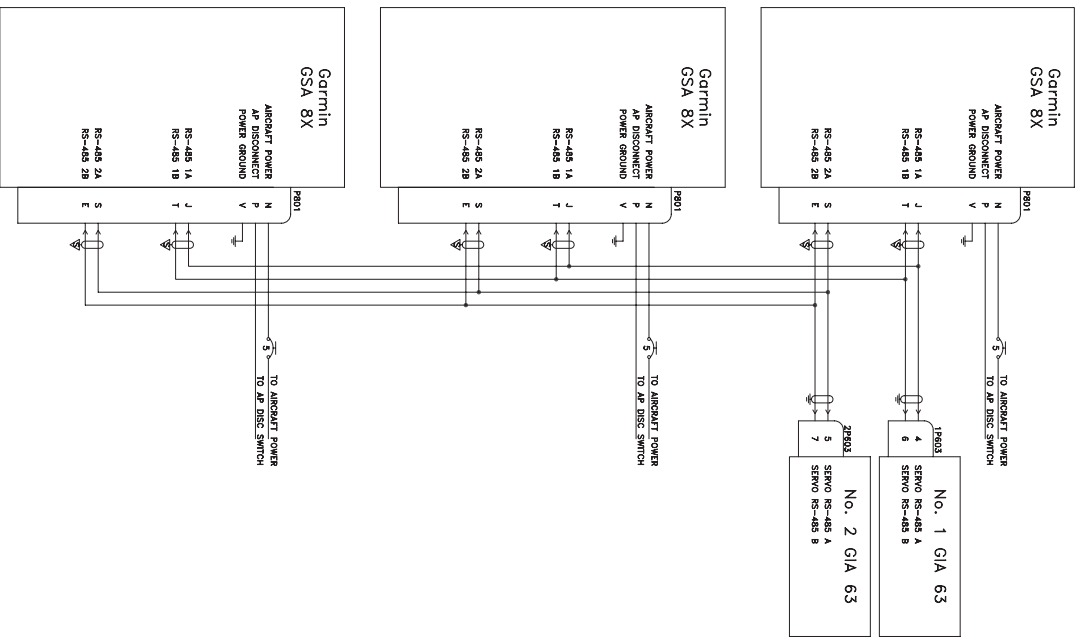

Figure A-16. Servo Motor And Gearbox Alignment



- NOTES
1. UNLESS OTHERWISE NOTED, ALL STRIPPED WIRE MUST CONFORM TO MIL-W-22759/18.
  2. UNLESS OTHERWISE NOTED, ALL SHIELDED WIRE MUST CONFORM TO MIL-C-27500.
  3. UNLESS OTHERWISE NOTED, ALL WIRE SIZE 24 GAUGE OR LARGER.
  4. SYMBOL DESIGNATIONS
- AIRCRAFT GROUND
  - CIRCUIT BREAKER
  - TWISTED SHIELDED 2 CONDUCTOR SHIELD TERMINATED TO GROUND
  - WIRE SPLICE CONNECTION
  - TWISTED SHIELDED 3 CONDUCTOR SHIELD TERMINATED TO GROUND
5. UNLESS OTHERWISE NOTED, ALL SHIELD GROUNDS MUST BE MADE TO THE RESPECTIVE UNIT BACKSHELLS. ALL OTHER GROUNDS SHOULD BE TERMINATED TO AIRCRAFT GROUND AS CLOSE TO THE RESPECTIVE UNIT AS POSSIBLE.

Figure B-1. GSA 8X Interconnect Diagram (Typical Three-Servo Installation)