

# VCD5500 Vehicle Cradle

Quick Reference Guide

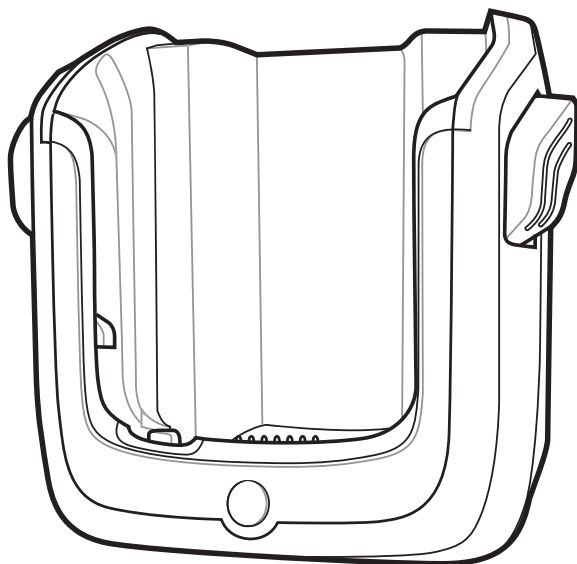

Zebra reserves the right to make changes to any product to improve reliability, function, or design.

Zebra does not assume any product liability arising out of, or in connection with, the application or use of any product, circuit, or application described herein.

No license is granted, either expressly or by implication, estoppel, or otherwise under any patent right or patent, covering or relating to any combination, system, apparatus, machine, material, method, or process in which Zebra products might be used. An implied license exists only for equipment, circuits, and subsystems contained in Zebra products.

Zebra and the Zebra head graphic are registered trademarks of ZIH Corp. The Symbol logo is a registered trademark of Symbol Technologies, Inc., a Zebra Technologies company. All other trademarks are the property of their respective owners.

Zebra Technologies Corporation  
Lincolnshire, IL U.S.A.  
<http://www.zebra.com>

## **Warranty**

For the complete Zebra hardware product warranty statement, go to:  
<http://www.zebra.com/warranty>.

## Introduction

This guide describes how to install and use a VCD5500 vehicle cradle with a Zebra MC55 Enterprise Digital Assistant.

Install the VCD5500 into your vehicle. Once installed, the cradle:

- holds the MC55 securely in place
- provides power for operating the MC55
- re-charges the battery in the MC55.

The cradle is powered by the vehicle's 12V or 24V electrical system. The operating voltage range is 9V to 32V and requires a maximum current of 3A.

## About This Guide

Specific topics in this guide include:

- [Requirements on page 3](#)
- [Parts on page 4](#)
- [Mounting the Cradle on page 5](#)
- [Power Connection on page 6](#)
- [MC55 Insertion and Removal on page 9](#)
- [MC55 Battery Charging on page 10](#)
- [LED Indicators on page 10](#)
- [Care and Cleaning on page 11](#)
- [Troubleshooting on page 11](#)
- [Regulatory Information on page 13](#)
- [Service Information on backcover.](#)

For detailed information about the series of MC55, refer to the *MC55 User Guide* (p/n 72E-108859-xx), and the *MC55 Integrator Guide* (p/n 72E-108861-xx).

## Requirements

For mounting:

- four #8-32 self-locking nuts (included)
- four #8 washers (included)
- a drill with a #6 drill bit (.204").

For power connection:

- power input cable (included), p/n 25-61987-01R
- UL Listed in-line fuse rated 250V, 5A (included), must be used if not connecting to vehicle's fuse panel
- in-line fuse holder (included), must be used if not connecting to vehicle's fuse panel.

## Parts

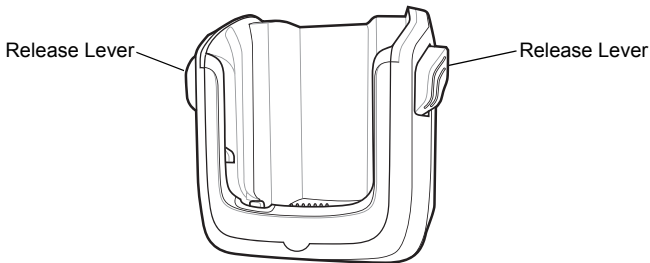

FRONT VIEW

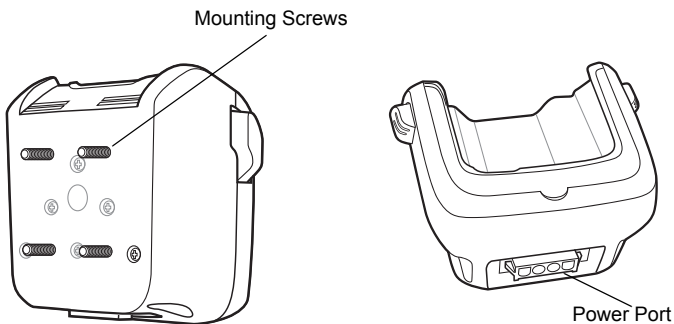

REAR VIEW

BOTTOM VIEW

## Connector Pin-Outs

### Power Input Cable

Pin	Signal
1	Chassis ground (Black Wire)
2	Chassis ground (Bare Wire)
3	V+ (Red Wire)
4	V+ (Red Wire)

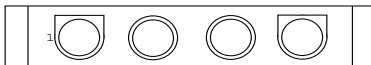

Connector on Power Cable



**CAUTION** ROAD SAFETY - Do not use the MC55 while driving. Park the vehicle first. Always ensure the MC55 is fully inserted into the cradle. Do not place it on the seat or where it can break loose in a collision or sudden stop. Lack of proper insertion may result in property damage or personal injury. Zebra is not responsible for any loss resulting from the use of the products while driving. Remember: Safety comes first.

## Mounting the Cradle



**CAUTION** Only mount the Vehicle Cradle in a vertical position with the release level at the top or in a horizontal position with the mobile computer display facing up. Never mount the vehicle cradle on the side or upside down or on a wall that can be subject to impact or collision of greater than 40Gs, in accordance with SAE J1455 Section 4.10.3.5

1. Select a mounting location for the cradle. It should be flat, and must provide adequate support for the cradle.

2. Prepare the mounting surface to accept four #8-32 studs, using the mounting template below. Drill four holes with a #6 drill bit.

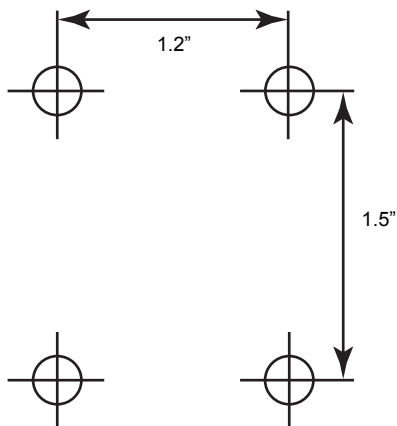

3. Position the cradle on the mounting surface.
4. Fasten it using four #8 washers and four #8-32 self-locking nuts.



**CAUTION** Do not install a Vehicle Cradle on or near an air bag cover plate or within an aerobic zone. Also, do not install it in a location that affects vehicle safety or driveability.

## Power Connection

Please read all of these instructions before beginning.



**WARNING!** A properly trained technician must perform the power connection. Improper connection can damage your vehicle, cradle or mobile computer. Refer to the vehicle's Owner's Manual for instructions for removing power.

To connect the cradle to power:



**CAUTION** When setting up connection for this cradle, only use the power input cable provided with this cradle.

1. Locate the vehicle power source.



**NOTE** The ideal location for connecting the vehicle cradle power input cable would be an accessory output in your vehicle's fuse panel. The vehicle cradle should be added to a circuit with a maximum load capacity for the cradle and the original circuit. Refer to the vehicle's *Owner's Manual* for identification of the circuit. If a fused output is not available, the vehicle cradle must be installed with the provided in-line fuse holder and UL Listed 5A fuse. The fuse protects the vehicle from an electrical short on the power line to the cradle. To use the cradle to charge the MC55 and spare battery, when the vehicle's ignition is off, connect the cradle to unswitched power.

2. Route the power input cable from the cradle's power port to the connection point for the vehicle's power source.



**NOTE** The means of routing and securing the power input cable from the cradle through to the vehicle power source is extremely important. Hazards associated with improper wiring can be severe. To avoid unintentional contact between the wire and any sharp edges, provide the cable with proper bushings and clamping where it passes through openings. If the wire is subjected to sharp surfaces and excess engine vibration, the wiring harness insulation can wear away, causing a short between the bare wire and chassis. This can start a fire. To avoid any mishaps, all wiring should be routed away from moving parts, high temperature areas and any contaminants.

3. When using the supplied in-line fuse holder (which must be used if not connecting to vehicle's fuse panel):
  - a. Ensure the fuse holder contains a 5A UL Listed slow-blow fuse.

- b. Splice the fuse holder to the end of the red V+ wire, as shown below. Make the distance from the fuse to the power connection point as short as possible.

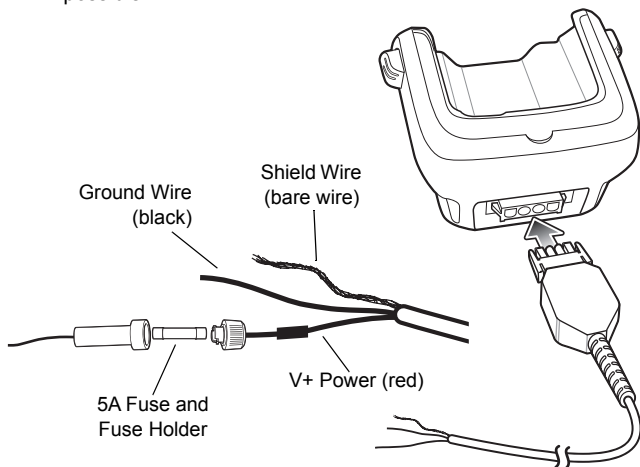

4. Prepare the cable termination.

- a. Red wire: connect to a +12/24 V vehicle power source.  
 b. Black wire and Shield wire: connect to vehicle ground wire or chassis ground.

✓ **NOTE** How the cable terminates depends on the vehicle. If the vehicle has a power output connector, then you must attach a mating connector to the end of the power cable. You may be able to connect to a fuse panel with a simple blade terminal or commercially available connector. Consult the vehicle *Owner's Manual* for information on how to access the power supply in the vehicle.

5. Connect the power input cable into the power port on the cradle.

To see if the cradle has power, insert the MC55. The Charging LED on the MC55 blinks slowly to indicate charging and turns solid amber when the battery is completely charged. See [LED Indicators on page 10](#) for other indications.



## MC55 Insertion and Removal

- ✓ **NOTE** The vehicle cradle supports the insertion and charging of an MC55 with a standard capacity or extended capacity battery.

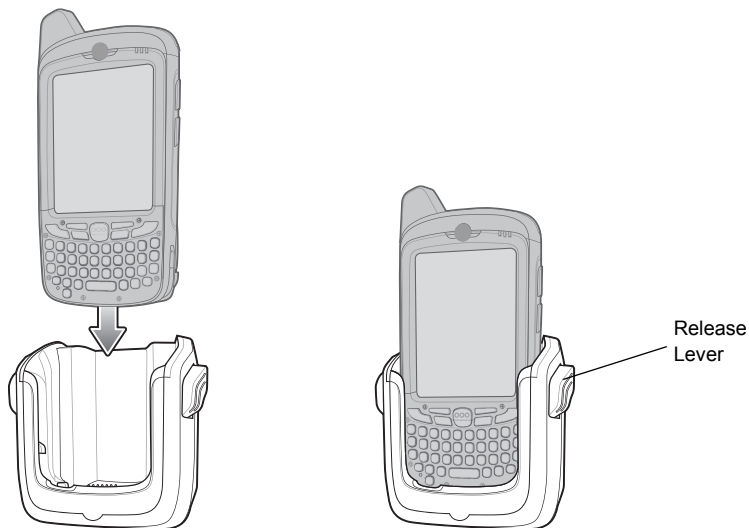

To ensure the MC55 was inserted correctly, listen for the audible click that signifies that the MC55 button release locking mechanism was enabled and the MC55 was locked into place.



- CAUTION** Ensure that the MC55 is fully inserted into the cradle. Lack of proper insertion may result in property damage or personal injury. Zebra Technologies Corporation is not responsible for any loss resulting from the use of the products while driving.

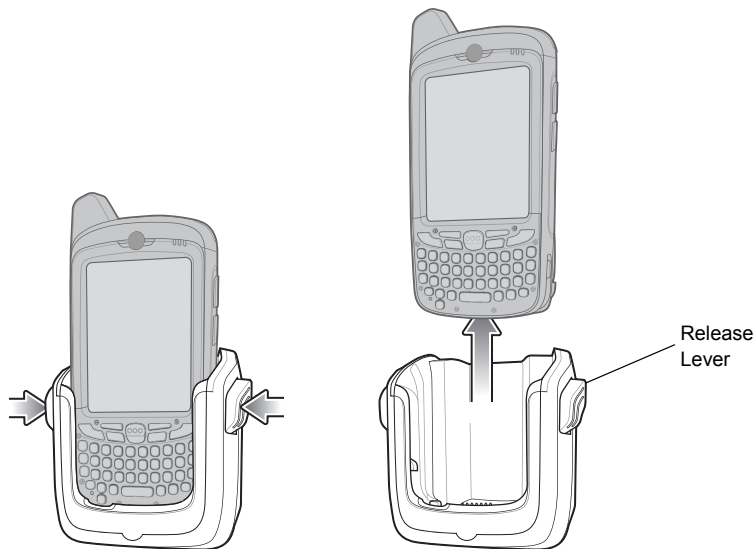

## MC55 Battery Charging

1. Ensure the cradle is connected to a power source. See [Power Connection on page 6](#).
2. Insert the MC55 into the cradle. See [MC55 Insertion and Removal on page 9](#).

The MC55 starts to charge through the cradle as soon as it is inserted. This does not deplete the vehicle battery significantly. The 2400 mAh battery charges in approximately four hours. The 3600 mAh battery charges in approximately eight hours. See [LED Indicators on page 10](#) for all charging indications.

## LED Indicators

LED	Indication
<b>MC55 Battery Charging (LED is on MC55)</b>	
Off	MC55 is not in cradle, MC55 is not placed correctly, or cradle is not powered.

LED	Indication
Fast Blinking Amber (twice a second)	Error in charging (not within battery charging temperature or charging for too long without completion). Check placement of MC55.
Slow Blinking Amber (once every two seconds)	MC55 is charging.
Solid Amber	Charging is complete.

## Care and Cleaning

Avoid getting oils, grease or gasoline on the cradle, and do not let debris gather in the bottom of the cradle slot. When necessary, clean the cradle with a mild cleaner. If you are not sure whether or not to use a particular cleaner, contact Zebra for advice.

## Troubleshooting

Symptom	Possible Cause	Action
MC55 battery charging LED does not light up.	Cradle is not receiving power.	Ensure the Power Input cable is securely connected to the cradle's Power Port.
MC55 battery is not recharging.	MC55 was removed from the cradle too soon.	Replace the MC55 in the cradle; you may have removed it before it was recharged. If a MC55 battery pack is fully depleted, it can take four hours to fully recharge a 2400 mAh battery and six hours for a 3600 mAh battery.
	Battery is faulty.	Replace the battery.
	MC55 was not placed correctly in the cradle.	Remove the MC55 from the cradle, and re-insert correctly. If the battery still does not charge, contact Customer Support. The MC55 battery charging LED slowly blinks amber when the MC55 is correctly inserted and charging.

# Health and Safety Recommendations

## Vehicle Installation

RF signals may affect improperly installed or inadequately shielded electronic systems in motor vehicles (including safety systems). Check with the manufacturer or its representative regarding your vehicle. You should also consult the manufacturer of any equipment that has been added to your vehicle.

An air bag inflates with great force. DO NOT place objects, including either installed or portable wireless equipment, in the area over the air bag or in the air bag deployment area. If in-vehicle wireless equipment is improperly installed and the air bag inflates, serious injury could result.

Position your device within easy reach. Be able to access your device without removing your eyes from the road.

Note: Connection to an alert device that will cause a vehicle horn to sound or lights to flash, on receipt of a call on public roads, is not permitted.

## ***Safety on the Road***

Do not take notes or use the device while driving. Jotting down a “to do” list or flipping through your address book takes attention away from your primary responsibility, driving safely.

When driving a car, driving is your first responsibility - Give full attention to driving. Check the laws and regulations on the use of wireless devices in the areas where you drive. Always obey them.

When using a wireless device behind the wheel of a car, practice good common sense and remember the following tips:

- Get to know your wireless device and any features such as speed dial and redial. If available, these features help you to place your call without taking your attention off the road.
- When available, use a hands free device.
- Let the person you are speaking with know you are driving; if necessary, suspend the call in heavy traffic or hazardous weather conditions. Rain, sleet, snow, ice, and even heavy traffic can be hazardous.
- Dial sensibly and assess the traffic; if possible, place calls when you are not moving or before pulling into traffic. Try to plan calls when your car will be stationary. If you need to make a call while moving, dial only a few numbers, check the road and your mirrors, then continue.

- Do not engage in stressful or emotional conversations that may be distracting. Make people you are talking with aware you are driving and suspend conversations that have the potential to divert your attention from the road.
- Use your wireless phone to call for help. Dial the Emergency services, (9-1-1 in the US, and 1-1-2 in Europe) or other local emergency number in the case of fire, traffic accident or medical emergencies. Remember, it is a free call on your wireless phone! The call can be made regardless of any security codes and depending on a network, with or without a SIM card inserted.
- Use your wireless phone to help others in emergencies. If you see an auto accident, crime in progress or other serious emergency where lives are in danger, call the Emergency Services, (9-1-1 in the US, and 1-1-2 in Europe) or other local emergency number, as you would want others to do for you.
- Call roadside assistance or a special non-emergency wireless assistance number when necessary. If you see a broken-down vehicle posing no serious hazard, a broken traffic signal, a minor traffic accident where no one appears injured, or a vehicle you know to be stolen, call roadside assistance or other special non-emergency wireless number.

“The wireless industry reminds you to use your device / phone safely when driving”.

## Regulatory Information

This guide applies to Model Number VCD5500.

All Zebra devices are designed to be compliant with rules and regulations in locations they are sold and will be labeled as required.

Any changes or modifications to Zebra equipment, not expressly approved by Zebra, could void the user's authority to operate the equipment.

For use only with Zebra approved and UL Listed mobile computers. Zebra approved and UL Listed accessories and/or Zebra approved and UL Listed/Recognized battery packs.



**CAUTION** Only use Zebra approved and UL listed accessories, battery packs and battery chargers.

Do NOT attempt to charge damp/wet mobile computers or batteries. All components must be dry before connecting to an external power source.

Declared maximum operating temperature 50°C.

Local language translations are available at the following web site:

[www.zebra.com/support](http://www.zebra.com/support)

## Radio Frequency Interference Requirements-FCC



Note: This equipment has been tested and found to comply with the limits for a Class B digital device, pursuant to Part 15 of the FCC rules. These limits are designed to provide reasonable protection against harmful interference in a residential installation. This equipment generates, uses and can radiate radio frequency energy and, if not installed and used in accordance with the instructions, may cause harmful interference to radio communications. However there is no guarantee that interference will not occur in a particular installation. If this equipment does cause harmful interference to radio or television reception, which can be determined by turning the equipment off and on, the user is encouraged to try to correct the interference by one or more of the following measures:

- Reorient or relocate the receiving antenna
- Increase the separation between the equipment and receiver
- Connect the equipment into an outlet on a circuit different from that to which the receiver is connected
- Consult the dealer or an experienced radio/TV technician for help.

## Radio Frequency Interference Requirements - Canada

This Class B digital apparatus complies with Canadian ICES-003.

Cet appareil numérique de la classe B est conforme à la norme NMB-003 du Canada.

## Marking and European Economic Area (EEA)

### Statement of Compliance

Zebra hereby declares that this device is in compliance with all applicable Directives, 2014/30/EU, 2014/35/EU and 2011/65/EU. The full text of the EU Declaration of Conformity is available at the following internet address:

<http://www.zebra.com/doc>.

## Batteries

### Taiwan - Recycling

EPA (Environmental Protection Administration) requires dry battery producing or importing firms in accordance with Article 15 of the Waste Disposal Act are required to indicate the recycling marks on the batteries used in sales, giveaway or promotion. Contact a qualified Taiwanese recycler for proper battery disposal.



「廢電池請回收」

### Battery Information

Zebra rechargeable battery packs are designed and constructed to the highest standards within the industry.

However, there are limitations to how long a battery can operate or be stored before needing replacement. Many factors affect the actual life cycle of a battery pack, such as heat, cold, harsh environmental conditions and severe drops.

When batteries are stored over six (6) months, some irreversible deterioration in overall battery quality may occur. Store batteries at half of full charge in a dry, cool place, removed from the equipment to prevent loss of capacity, rusting of metallic parts and electrolyte leakage. When storing batteries for one year or longer, the charge level should be verified at least once a year and charged to half of full charge.

Replace the battery when a significant loss of run time is detected.

Standard warranty period for all Zebra batteries is one year, regardless if the battery was purchased separately or included as part of the mobile computer. For more information on Zebra batteries, please visit:

<http://www.zebra.com/batterybasics>

### Battery Safety Guidelines

- The area in which the units are charged should be clear of debris and combustible materials or chemicals. Particular care should be taken where the device is charged in a non commercial environment.
- Follow battery usage, storage, and charging guidelines found in the user's guide.
- Improper battery use may result in a fire, explosion, or other hazard.
- To charge the mobile device battery, the battery and charger temperatures must be between +32°F and +104°F (0°C and +40°C).
- Do not use incompatible batteries and chargers. Use of an incompatible battery or charger may present a risk of fire, explosion, leakage, or other

hazard. If you have any questions about the compatibility of a battery or a charger, contact Zebra support.

- To enable authentication of approved batteries, as required by IEEE1725 clause 10.2.1, the 2400 mAh battery (p/n BTRY-MC55EAB00) and the 3600 mAh battery (p/n BTRY-MC55EAB02) contain a hologram. Do not install any battery without checking it has the authentication hologram.
- Do not disassemble or open, crush, bend or deform, puncture, or shred.
- Severe impact from dropping any battery-operated device on a hard surface could cause the battery to overheat.
- Do not short circuit a battery or allow metallic or conductive objects to contact the battery terminals.
- Do not modify or remanufacture, attempt to insert foreign objects into the battery, immerse or expose to water or other liquids, or expose to fire, explosion, or other hazard.
- Do not leave or store the equipment in or near areas that might get very hot, such as in a parked vehicle or near a radiator or other heat source. Do not place battery into a microwave oven or dryer.
- Battery usage by children should be supervised.
- Please follow local regulations to promptly dispose of used re-chargeable batteries.
- Do not dispose of batteries in fire.
- Seek medical advice immediately if a battery has been swallowed.
- In the event of a battery leak, do not allow the liquid to come in contact with the skin or eyes. If contact has been made, wash the affected area with large amounts of water and seek medical advice.
- If you suspect damage to your equipment or battery, contact Zebra support to arrange for inspection.

## **Japan (VCCI) - Voluntary Control Council for Interference**

### ***Class B ITE***

この装置は、情報処理装置等電波障害自主規制協議会（VCCI）の基準に基づくクラスB情報技術装置です。この装置は、家庭環境で使用することを目的としていますが、この装置がラジオやテレビジョン受信機に近接して使用されると、受信障害を引き起こすことがあります。取扱説明書に従って正しい取り扱いをして下さい。

This is a Class B product based on the standard of the Voluntary Control Council for Interference from Information Technology Equipment (VCCI). If this is used



near a radio or television receiver in a domestic environment, it may cause radio interference. Install and use the equipment according to the instruction manual.



## Waste Electrical and Electronic Equipment (WEEE)

**English:** For EU Customers: All products at the end of their life must be returned to Zebra for recycling. For information on how to return product, please go to:  
<http://www.zebra.com/weee>.

**Français:** Clients de l'Union Européenne : Tous les produits en fin de cycle de vie doivent être retournés à Zebra pour recyclage. Pour de plus amples informations sur le retour de produits, consultez : <http://www.zebra.com/weee>.

**Español:** Para clientes en la Unión Europea: todos los productos deberán entregarse a Zebra al final de su ciclo de vida para que sean reciclados. Si desea más información sobre cómo devolver un producto, visite: <http://www.zebra.com/weee>.

**Bulgarian:** За клиенти от ЕС: След края на полезния им живот всички продукти трябва да се връщат на Zebra за рециклиране. За информация относно връщането на продукти, моля отидете на адрес: <http://www.zebra.com/weee>.

**Deutsch:** Für Kunden innerhalb der EU: Alle Produkte müssen am Ende ihrer Lebensdauer zum Recycling an Zebra zurückgesandt werden. Informationen zur Rücksendung von Produkten finden Sie unter <http://www.zebra.com/weee>.

**Italiano:** per i clienti dell'UE: tutti i prodotti che sono giunti al termine del rispettivo ciclo di vita devono essere restituiti a Zebra al fine di consentirne il riciclaggio. Per informazioni sulle modalità di restituzione, visitare il seguente sito Web:  
<http://www.zebra.com/weee>.

**Português:** Para clientes da UE: todos os produtos no fim de vida devem ser devolvidos à Zebra para reciclagem. Para obter informações sobre como devolver o produto, visite: <http://www.zebra.com/weee>.

**Nederlands:** Voor klanten in de EU: alle producten dienen aan het einde van hun levensduur naar Zebra te worden teruggezonden voor recycling. Raadpleeg <http://www.zebra.com/weee> voor meer informatie over het terugzenden van producten.

**Polski:** Klienci z obszaru Unii Europejskiej: Produkty wycofane z eksploatacji należy zwrócić do firmy Zebra w celu ich utylizacji. Informacje na temat zwrotu produktów znajdują się na stronie internetowej <http://www.zebra.com/weee>.

**Čeština:** Pro zákazníky z EU: Všechny produkty je nutné po skončení jejich životnosti vrátit společnosti Zebra k recyklaci. Informace o způsobu vrácení produktu najdete na webové stránce: <http://www.zebra.com/weee>.

**Eesti:** EL klientidele: kõik tooted tuleb nende eluea lõppedes tagastada taaskasutamise eesmärgil Zebra'ile. Lisainformatsiooni saamiseks toote tagastamise kohta külastage palun aadressi: <http://www.zebra.com/weee>.

**Magyar:** Az EU-ban vásárlóknak: Minden tönkrement termékét a Zebra vállalathoz kell eljuttatni újrahasznosítás céljából. A termék visszajuttatásának módjával kapcsolatos tudnivalóért látogasson el a <http://www.zebra.com/weee> weboldalra.

**Românesc:** Pentru clienții din UE: Toate produsele, la sfârșitul duratei lor de funcționare, trebuie returnate la Zebra pentru reciclare. Pentru informații despre returnarea produsului, accesați: <http://www.zebra.com/weee>.

**Slovenski:** Za kupce v EU: vsi izdelki se morajo po poteku življenjske dobe vrniti podjetju Zebra za reciklažo. Za informacije o vračilu izdelka obiščite: <http://www.zebra.com/weee>.

**Svenska:** För kunder inom EU: Alla produkter som uppnått sin livslängd måste returneras till Zebra för återvinning. Information om hur du returnerar produkten finns på <http://www.zebra.com/weee>.

**Suomi:** Asiakkaat Euroopan unionin alueella: Kaikki tuotteet on palautettava kierrätettäväksi Zebra-yhtiöön, kun tuotetta ei enää käytetä. Lisätietoja tuotteen palauttamisesta on osoitteessa <http://www.zebra.com/weee>.

**Dansk:** Til kunder i EU: Alle produkter skal returneres til Zebra til recirkulering, når de er udtjent. Læs oplysningerne om returnering af produkter på: <http://www.zebra.com/weee>.

**Ελληνικά:** Για πελάτες στην Ε.Ε.: Όλα τα προϊόντα, στο τέλος της διάρκειας ζωής τους, πρέπει να επιστρέφονται στην Zebra για ανακύκλωση. Για περισσότερες πληροφορίες σχετικά με την επιστροφή ενός προϊόντος, επισκεφθείτε τη διεύθυνση <http://www.zebra.com/weee> στο Διαδίκτυο.

**Malti:** Għal klijenti fl-EU: il-prodotti kollha li jkunu waslu fl-aħħar tal-ħajja ta' l-użu tagħhom, iridu jiġu rritornati għand Zebra għar-riċiklaġġ. Għal aktar tagħrif dwar kif għandek tiritorna l-prodott, jekk jogħġbok żur: <http://www.zebra.com/weee>.

**Slovenski:** Za kupce v EU: vsi izdelki se morajo po poteku življenjske dobe vrniti podjetju Zebra za reciklažo. Za informacije o vračilu izdelka obiščite: <http://www.zebra.com/weee>.

**Slovenčina:** Pre zákazníkov z krajín EU: Všetky výrobky musia byť po uplynutí doby ich životnosti vrátené spoločnosti Zebra na recykláciu. Bližšie informácie o vrátení výrobkov nájdete na: <http://www.zebra.com/weee>.

**Lietuvių:** ES vartotojams: visi gaminiai, pasibaigus jų eksploatacijos laikui, turi būti gražinti utilizuoti į kompaniją „Zebra“. Daugiau informacijos, kaip gražinti gaminį, rasite: <http://www.zebra.com/weee>.

**Latviešu:** ES klientiem: visi produkti pēc to kalpošanas mūža beigām ir jānogādā atpakaļ Zebra otrreizējai pārstrādei. Lai iegūtu informāciju par produktu nogādāšanu Zebra, lūdzu, skatiet: <http://www.zebra.com/weee>.



## Service Information

If you have a problem using the equipment, contact your facility's Technical or Systems Support. If there is a problem with the equipment, they will contact the Zebra Support at: [www.zebra.com/support](http://www.zebra.com/support).

For the latest version of this guide go to:

[www.zebra.com/support](http://www.zebra.com/support).



Zebra Technologies Corporation  
Lincolnshire, IL U.S.A.  
<http://www.zebra.com>

Zebra and the stylized Zebra head are trademarks of ZIH Corp., registered in many jurisdictions worldwide. All other trademarks are the property of their respective owners.

©2016 Symbol Technologies LLC, a subsidiary of Zebra Technologies Corporation. All rights reserved.



72-114283-03 Revision A - October 2016