

AIR-TO-WATER SCROLL HEAT PUMP WITH GREENSPEED® INTELLIGENCE



Unit with low noise level option

- High full and part-load efficiency
- Compact and simple to install
- Low sound level
- Low refrigerant charge
- Superior reliability

30RQM/30RQP



Nominal heating capacity 179-434 kW
Nominal cooling capacity 154-510 kW

The AquaSnap® heat pumps are the best value solution for commercial and industrial applications where installers, consultants and building owners require reduced installed costs, optimal performances and maximum quality.

The new generation AquaSnap® features two new versions:

- The AquaSnap® (30RQM) version features a compact all-in-one package optimised for full-load applications where reduced investment cost (low Capex) is required.
- The AquaSnap Greenspeed® (30RQP) version features a compact all-in-one package optimised for part-load applications where high SCOP and SEER are required. The AquaSnap Greenspeed® equipped with variable speed fans and variable speed pump provides premium part load efficiency to reduce utility costs over the lifespan of the heat pump. Additionally, the low sounds levels achieved at part load conditions can be very beneficial for sensitive acoustic applications.



CARRIER participates in the ECP programme for LCP/HP
Check ongoing validity of certificate:
www.eurovent-certification.com

AQUASNAP® WITH GREENSPEED INTELLIGENCE

SIMPLICITY

The simplicity of AquaSnap®, tried and trusted

■ Experience

With more than 60,000 units installed since 1998, AquaSnap® sets the standard in “plug & play” air conditioning and heating solutions. Compact and simple to install, the new generation of AquaSnap® with Greenspeed intelligence combines **trusted reliability with even more innovation.**

■ Easy installation

AquaSnap® integrates an hydraulic module with pressure transducers for digital water flow rate display on the user interface and pump protection against low hydraulic pressure.

The **variable-speed pump allows easy and fast installation start-up** thanks to the electronic setting of the nominal water flow.

■ Adaptability

The new AquaSnap® heat pumps can operate in all climates with large operating maps in cooling and heating modes. Thanks to special coil coatings, the AquaSnap® heat pumps can withstand operation in corrosive environments. To match specific commercial or industrial application requirements, the unit can be equipped with multiple options.

THE STANDARD IN
«PLUG & PLAY»
AIR CONDITIONING AND
HEATING SOLUTIONS

UP TO 15% MORE EFFICIENCY
WITH THE SAME DIMENSIONS AS
PREVIOUS GENERATION

ONE PRODUCT FOR
MANY APPLICATIONS

&

INTELLIGENCE

Greenspeed intelligence: the smart innovation

■ Smart efficiency

The new generation of AquaSnap® heat pumps delivers on the energy savings and reduced carbon footprint required by the latest European regulations. AquaSnap® heat pumps with Greenspeed intelligence offer **Seasonal Coefficient of Performance (SCOP) in heating of up to 3.35 and Seasonal Energy Efficiency (SEER) in cooling of up to 4.11**, making them the best value air conditioning solution in commercial and industrial applications.

■ Acoustic comfort

Thanks to the variable-speed fans, AquaSnap® heat pumps with Greenspeed intelligence offer **smooth fan speed variation during partial load operation.** For noise sensitive environments during both night and day, the AquaSnap® noise level can be automatically factory-set or tuned on-site.

■ Advanced control

An advanced control algorithm calculates energy efficiency and **readjusts fan speed in real time** to reduce energy consumption. «Free Defrost», an **innovative defrosting solution**, can significantly improve the SCOP of the heat pump during positive outside air temperature conditions. For further energy savings, the water flow rate can be **electronically controlled** to meet real application needs, thus significantly reducing pumping energy consumption both night and day.

LIFETIME ENERGY SAVINGS

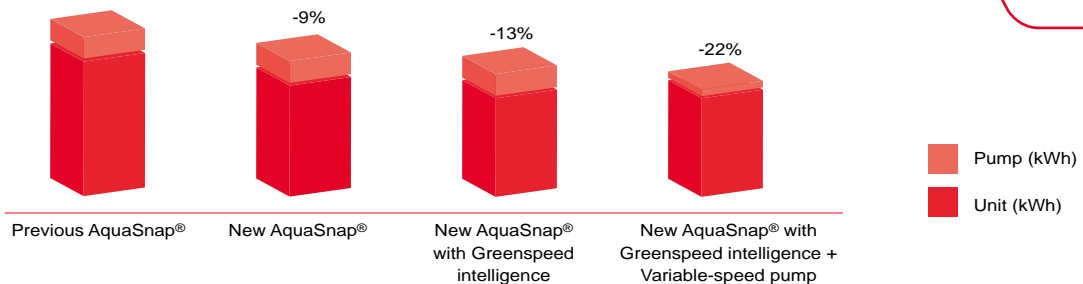

Source: Carrier estimates based on 15-year energy savings calculations comparing a 400kW AquaSnap® heat pump of the previous generation to a new AquaSnap® heat pump, a new AquaSnap® Greenspeed heat pump with variable speed pump in a variable primary flow water system design at an office building in an average European climate, 3500 running hours and 1000 stand-by hours per year. This information is intended as an example for comparison purposes only.

30RQM TECHNICAL INSIGHT

AquaSnap® scroll heat pumps 30RQM



**FIXED-SPEED
FLYING BIRD® FAN**



SmartView CONTROL

- 4.3" user-friendly touch screen
- All main parameters displayed on one screen
- Direct access to the unit's technical drawings and main service documents
- Easy remote monitoring via the internet
- Easy and secured access to unit parameters
- Smart Energy Monitoring provide in real time energy consumption, Cooling and Heating capacity, instantaneous and average seasonal energy efficiency ratios



COPPER ALUMINIUM COILS

- Heat shrinkable tube to protect distribution capillary tubes
- Coil electric resistance heaters to prevent ice formation and ease condensate draining during defrost



HEAT EXCHANGER

- True dual-circuit brazed plate heat exchanger with asymmetric channels

30RQP TECHNICAL INSIGHT

AquaSnap® scroll heat pumps with Greenspeed intelligence 30RQP

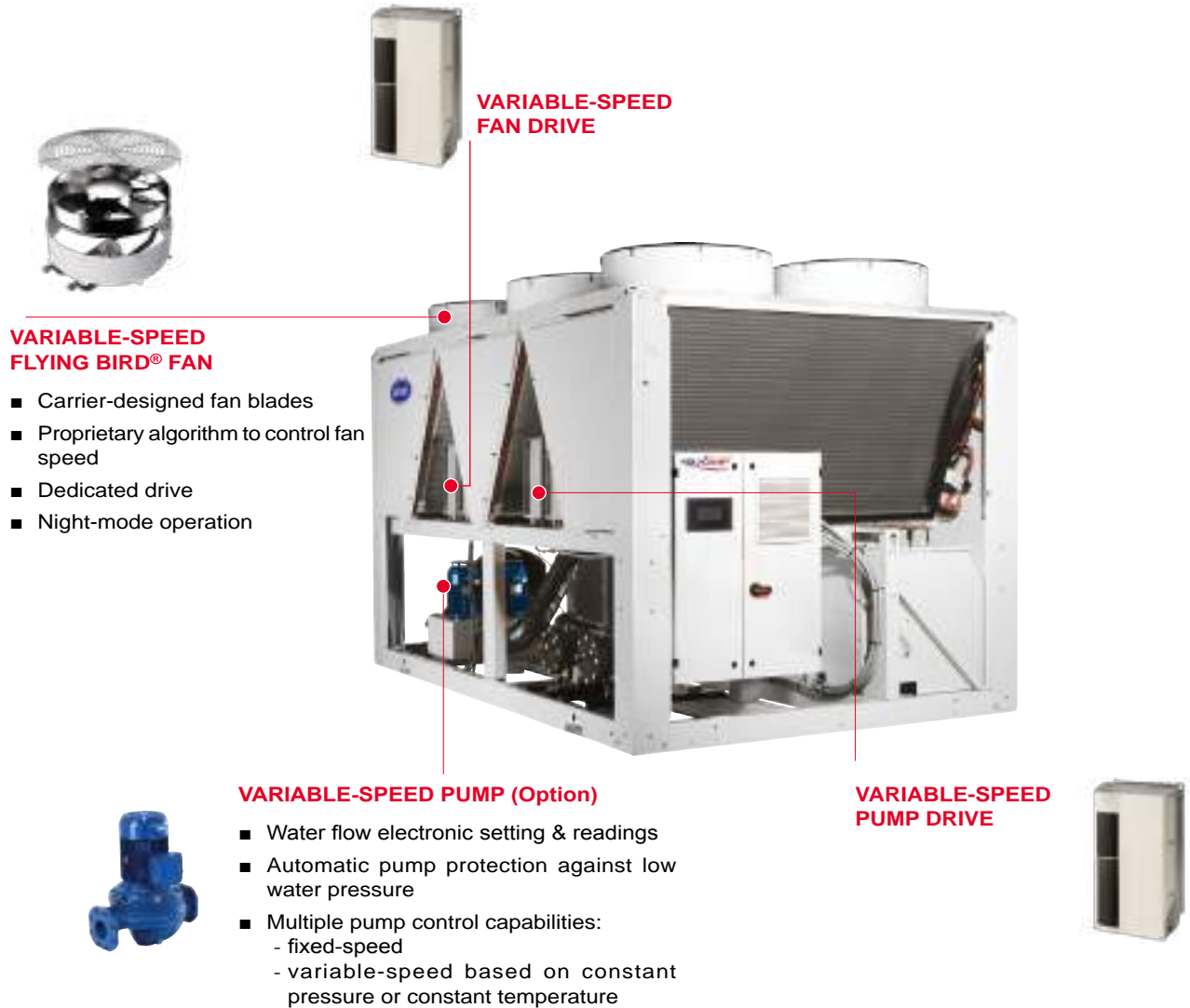

FEATURES AND BENEFITS

The AquaSnap® heat pumps are designed to meet current and future Ecodesign and F-Gas European regulation requirements in terms of energy efficiency and reduced CO₂ emissions. They use the best technologies available today:

- Reduced refrigerant charge of non-ozone depleting R-410A refrigerant
- Scroll compressors
- Greenspeed® variable-speed driven fans (30RQP models)
- Brazed plate heat exchangers with reduced pressure drops
- Auto-adaptive microprocessor control with Greenspeed® intelligence
- Smart View control with web connectivity possibilities and colour touch screen user display
- Extra energy savings through partial heat recovery

Both AquaSnap® versions can be equipped with an integrated hydraulic module, limiting the installation to conventional operations such as connection of the power supply and the supply and return piping (plug & play), according to the dimensions of the standard unit.

Recommended by Carrier, AquaSnap® can be equipped with one or two Greenspeed® variable-speed pumps to significantly reduce energy costs linked to pumping (reduction of more than two-thirds), ensure optimum water flow rate control, and improve overall system reliability.



Highly economical operation

- High unit full and part load energy efficiency and efficient design of the water side:
 - Standardised Eurovent values in accordance with EN 14511-3:2013 EER up to 2.9 (30RQP version)
 - 30RQP and 30RQM ranges are compliant with EU Ecodesign Tier 2 Minimum Efficiency Performance Standards (MEPS) in heating that apply from September 2017
 - Multiple scroll compressors equipped with a high-efficiency motor that permit exact matching of the capacity to the load
 - Electronic expansion device permitting operation at a lower condensing pressure and improved utilisation of the evaporator heat exchange surface (superheat control)
 - Air heat exchanger with Greenspeed® variable speed fans (30RQP version)
 - Low pressure drop brazed plate heat exchangers (pressure drops < 45 kPa at Eurovent conditions).
- Specific control functions to reduce unit energy use during occupied and unoccupied periods:
 - Internal timer programming: Permits heat pump on/off control and operation at a second set-point
 - Set-point automatically offset based on the outside air temperature or room air temperature (via an option)
 - Floating high-pressure management
 - Variable-speed fan control
 - Cooling and heating demand limitation.

Refer to control chapter for more information.

- On Heat pump version 30RQM/30RQP specific Free Defrost algorithm to optimise performance & comfort even during defrost period.

- Greenspeed® variable-speed pump to reduce pumping energy use up to 2/3 (option recommended by Carrier):
 - Eliminate energy losses through the water flow rate control valve by electronically setting the nominal water flow rate
 - Save energy during stand-by periods or part-load operation by automatically reducing the water pump speed. The energy consumption of the pump motor varies according to the cube of the speed, so that a reduction in speed of just 40% can reduce energy consumption by 80%
 - Improved unit part-load performance (Increased SCOP and SEER values with variable water flow rate as per the EN14825 standard).

Refer to hydraulic option chapter for more information.



Extra energy savings through partial heat recovery option that permits free hot water production.

Reduced maintenance costs

- Fast diagnosis of possible incidents and their history via the control
- R-410A refrigerant is easier to use than other refrigerant blends.

Low sound level

Coil section with fixed speed fans (30RQM models):

- Condenser coils in V-shape with an open angle, allowing quieter air flow across the coil
- Low-noise 4th generation Flying Bird fans, made of a composite material (Carrier patent)
- Rigid fan installation for reduced noise (Carrier patent).

Coil section with Greenspeed® variable-speed fans (30RQP models recommended by Carrier for even quieter operation):

- Exceptional acoustic signature during part-load operation through smooth fan speed variation.

■ Specific control functions or features to reduce noise level during night or unoccupied periods:

- Night time sound control with capacity and fan speed limitation
- Low-noise scroll compressors with low vibration level
- The compressor assembly is installed on an independent chassis and supported by flexible anti-vibration mountings.
- Dynamic suction and discharge piping support, minimising vibration transmission (Carrier patent)
- Acoustic compressor enclosure, reducing radiated noise emissions (option).



FEATURES AND BENEFITS

Quick and easy installation

- Compact design
 - The AquaSnap® units are designed to offer compact dimensions and low weight for easy installation.
- Integrated hydraulic module (option)
 - Low or high-pressure water pump (as required)
 - Single or dual pump (as required) with operating time balancing and automatic changeover to the back-up pump if a fault develops
 - Water filter protecting the water pump against circulating debris
 - Pressure transducers for direct numerical display of the water flow rate and water pressures
 - Thermal insulation and frost protection down to -20 °C, using an electric resistance heater (option)
 - High-capacity membrane expansion tank (option).
- Integrated hydraulic module with Greenspeed® variable-speed pump (option recommended by Carrier)
 - Quick and easy electronic setting of the nominal water flow rate when the unit is commissioned, thus eliminating the need to adjust the water flow rate control valve
 - Automatic control of the pump speed based on constant speed, constant pressure difference or constant temperature difference.
- Simplified electrical connections
 - A single power supply point without neutral
 - Main disconnect switch with high trip capacity
 - 24 V control circuit without risk from a transformer included.
- Fast unit commissioning
 - Systematic factory test before shipment
 - Quick-test function for step-by-step verification of the sensors, electrical components and motors.

Reduced installation costs

- Optional Greenspeed® variable-speed pump with hydraulic module (option recommended by Carrier)
 - Elimination of the water flow control valve cost
 - Water system design with variable primary flow (VPF) can provide significant installation cost savings compared with traditional constant primary-variable secondary systems; elimination of the secondary distribution pump, etc.
 - Water system design with fan coils fitted with 2-way valves instead of 3-way valves.

Environmental responsibility

- R-410A non-ozone depleting refrigerant.
- Reduced direct warming potential (10% of total equivalent warming impact):
 - Low R410-A refrigerant charge
 - Leak-tight refrigerant circuit with minimum brazed connections
 - Qualified Carrier maintenance personnel to provide refrigerant servicing
 - ISO 14001 manufacturing site.
- Reduced indirect warming potential (90% of total equivalent warming impact):
 - Reduced unit energy use (high full- and part-load efficiency)
 - Pumping energy consumption can be reduced by up to 2/3 using Greenspeed® variable-speed pumps.
- Refrigerant leak detection: Available as an option, this additional dry-contact allows reporting of possible leaks. The leak detector (by others) should be mounted in the most likely leak location. An Immediate customer notification of refrigerant losses to the atmosphere, allowing timely corrective actions.

Superior reliability

- State-of-the-art concept
 - Two independent refrigerant circuits; the second one automatically takes over if the first one develops a fault, maintaining partial cooling under all circumstances
 - All compressor components are easily accessible on site, minimising downtime
 - V-coil design to protect the coils against hail impact
 - Optional anti-corrosion coil coating for use in moderately corrosive environments.
 - Electronic flow switch. Auto-setting according to cooler size and fluid type
- Auto-adaptive control
 - Control algorithm prevents excessive compressor cycling and reduces the quantity of water in the water loop (Carrier patent)
 - Automatic compressor unloading in case of abnormally high condensing pressure
 - Automatic fan speed adjustment in case of coil fouling (30RQP models)
 - Smooth fan start to increase unit lifetime (30RQP models).
- Exceptional endurance tests
 - Partnerships with specialised laboratories and use of simulation tools (finite element analysis) for the design of critical components
 - Transport simulation test on an endurance circuit based on a military standard.

FEATURES AND BENEFITS

SMART VIEW Control

The Smart View features a control with advanced communication technology over Ethernet (IP), user-friendly and intuitive user interface with 4"3 colour touch screen.

- Energy management configuration
 - Internal time schedule clock: Controls heat pump on/off times and operation at a second set-point
 - Set-point offset based on the outside air temperature
 - Master/slave control of two heat pumps operating in parallel with operating time equalisation and automatic change-over in case of a unit fault.
 - Innovative smart energy monitoring, providing users with smart data such as real time electric energy consumption, cooling/heating capacity, and instantaneous and average seasonal energy efficiency ratios.
- Advanced communication features
 - Night mode: Capacity and fan speed limitation for reduced noise level
 - With hydraulic module: Water pressure display and water flow rate calculation
 - High-speed user-friendly communication technology over Ethernet (IP) to a centralised building management system
 - Access to multiple unit parameters.
- Functionality of maintenance
 - Compulsory maintenance reminder– FGAS sealing check
 - Periodic maintenance reminder Maintenance alarm which can be configured to days, months or hours of operation
- 4"3-inch Smart View user interface



- Intuitive and user-friendly 4"3 inch touch screen interface
- Concise and clear information is available in local languages
- Complete menu, customised for different users (end user, service personnel or Carrier engineers).

Remote management (standard)

Units with Smart View control can be easily accessed from the internet, using a PC with an Ethernet connection. This makes remote control quick and easy and offers significant advantages for service operations.

The AquaSnap® is equipped with an RS485 serial port that offers multiple remote control, monitoring and diagnostic possibilities. Carrier offers a vast choice of control products, specially designed to control, manage and supervise an air conditioning system. Please consult your Carrier representative for more information.

The AquaSnap® also communicates with other centralised building management systems via optional communication gateways.

A connection terminal allows remote control of the AquaSnap® by wired cable:

- Start/stop: Opening of this contact will shut down the unit
- Dual set-point: closing of this contact activates a second set-point (e.g.: unoccupied mode).
- Demand limit: Closing of this contact limits the maximum heat pump capacity to a predefined value.
- Operation indication: This volt-free contact indicates that the heat pump is operating (cooling load).
- Alarm indication: This volt-free contact indicates the presence of a major fault that has led to the shut-down of one or several refrigerant circuits.

Energy management module (option)

The Energy Management Module offers extended remote control possibilities:

- Room temperature: Permits set-point reset based on the building indoor air temperature (with Carrier thermostat)
- Set-point reset: Ensures reset of the cooling set-point based on a 4-20 mA
- Demand limit: Permits limitation of the maximum heat pump power based on a 4-20 mA signal
- Demand limit 1 and 2: Closing of these contacts limits the maximum heat pump power or current to two predefined values.
- User safety: This contact can be used for any customer safety loop; opening the contact generates a specific alarm.
- Ice storage end: When ice storage has finished, this input permits return to the second set-point (unoccupied mode).
- Time schedule override: Closing of this contact cancels the time schedule effects.
- Out of service: This signal indicates that the heat pump is completely out of service.
- Unit capacity: This analogue output (0-10 V) gives an immediate indication of the unit capacity.
- Alert indication: This volt-free contact indicates the necessity to carry out a maintenance operation or the presence of a minor fault.
- Boiler control: This on/off output controls an independent boiler to provide hot water.
- Electric heater control: this on/off output controls up to 4 electric heater stages to provide additional heating capacity during the cold season.

OPTIONS

Options	No.	Description	Advantages	Use
Corrosion protection, traditional coils	3A	Fins made of pre-treated aluminium (polyurethane and epoxy)	Improved corrosion resistance, recommended for moderate marine and urban environments	30RQM/30RQP 160-520
Low temperature brine solution	6B	Low temperature chilled water production down to -8°C with ethylene or propylene glycol	Covers specific applications such as ice storage and industrial processes	30RQP 180-230-270-310
High static fans	12	Unit equipped with high static variable speed fan (maximum 200Pa), each fan being equipped with a connection flange allowing the connection to the ducting system.	Ducted fan discharge, optimised temperature control, based on the operating conditions and system characteristics	30RQM/30RQP 160-520
Low noise level	15	Aesthetic and sound absorbing compressor enclosure	Noise level reduction by 1 to 2 dB(A)	30RQM/30RQP 160-520
Very low noise level	15LS	Acoustic compressor enclosure and low-speed fans	Noise level reduction for sensible site	30RBM 160-520
IP54 control box	20A	Increased leak tightness of the unit	Protects the inside of the electric box from dust, water and sand. In general this option is recommended for installations in polluted environments	30RQM/30RQP 160-520
Grilles and enclosure panels	23	Metal grilles on the 4 unit sides, plus side enclosure panels at each end of the coils	Improves aesthetics, protection against intrusion to the unit interior, coil and piping protection against impacts.	30RQM/30RQP 160-520
Enclosure panels	23A	Side enclosure panels at each end of the coil	Improves aesthetics, coil and piping protection against impacts.	30RQM/30RQP 160-520
Soft Starter	25	Electronic starter on each compressor	Reduced start-up current	30RQM/30RQP 160-520
Winter operation down to -20°C	28	Fan speed control of lead fan for each circuit using a variable frequency drive	Stable unit operation for outside air temperatures from 0°C down to -20°C in cooling mode	30RQM 160-520
Water exchanger frost protection	41	Electric heater on the water exchanger and the water piping	Water exchanger module frost protection between 0°C and -20°C outside air temperature	30RQM/30RQP 160-520
Exchanger & hydraulic frost protection	42A	Electric heater on the water exchanger hydraulic module and optional expansion tank	Water exchanger and hydraulic module frost protection down to an outside air temperature of -20°C	30RQM/30RQP 160-520
Partial heat recovery	49	Unit equipped with one desuperheater on each refrigerant circuit	Production of free high-temperature hot-water simultaneously with chilled water production (or hot water for Heat pump)	30RQM/30RQP 160-520
Master/slave operation	58	Unit equipped with supplementary water outlet temperature sensor kit to be field-installed allowing master/slave operation of two units connected in parallel	Optimised operation of two units connected in parallel operation with operating time equalisation	30RQM/30RQP 160-520
Compressor discharge valves	93A	Shut-off valves on the compressor discharge piping	Simplified maintenance. Possibility to store the refrigerant charge in the condenser side during servicing	30RQM/30RQP 160-520
HP single-pump hydraulic module	116R	Single high-pressure water pump, water filter, electronic water flow control, pressure transducers. For more details, refer to the dedicated chapter (expansion tank not included. Option with built-in hydraulic safety components available)	Easy and fast installation (plug & play)	30RQM/30RQP 160-520
HP dual-pump hydraulic module	116S	Dual high-pressure water pump, water filter, electronic water flow control, pressure transducers. For more details, refer to the dedicated chapter (expansion tank not included. Option with built-in hydraulic safety components available)	Easy and fast installation (plug & play)	30RQM/30RQP 160-520
LP single-pump hydraulic module	116T	Single low-pressure water pump, water filter, electronic water flow control, pressure transducers. For more details, refer to the dedicated chapter (expansion tank not included. Option with built-in hydraulic safety components available)	Easy and fast installation (plug & play)	30RQM/30RQP 160-520
LP dual-pump hydraulic module	116U	Dual low-pressure water pump, water filter, electronic water flow control, pressure transducers. For more details, refer to the dedicated chapter (expansion tank not included. Option with built-in hydraulic safety components available)	Easy and fast installation (plug & play)	30RQM/30RQP 160-520
Evap. HP variable-speed single-pump	116V	Single high-pressure water pump with variable speed drive (VSD), water filter, electronic water flow control, pressure transducers. Multiple possibilities of water flow control. For more details, refer to the dedicated chapter (expansion tank not included. Option with built-in hydraulic safety components available)	Easy and fast installation (plug & play), significant pumping energy cost savings (more than two-thirds), tighter water flow control, improved system reliability	30RQM/30RQP 160-520

OPTIONS

Options	No.	Description	Advantages	Use
HP VSD dual-pump hydraulic mod.	116W	Dual high-pressure water pump with variable speed drive (VSD), pressure transducers. Multiple possibilities of water flow control. For more details, refer to the dedicated chapter (expansion tank not included. Option with built-in hydraulic safety components available)	Easy and fast installation (plug & play), significant pumping energy cost savings (more than two-thirds), tighter water flow control, improved system reliability	30RQM/30RQP 160-520
Lon gateway	148D	Two-directional communication board complying with LonTalk protocol	Connects the unit by communication bus to a building management system	30RQM/30RQP 160-520
Bacnet over IP	149	Two-directional high-speed communication using BACnet protocol over Ethernet network (IP)	Easy and high-speed connection by ethernet line to a building management system. Allows access to multiple unit parameters	30RQM/30RQP 160-520
Modbus over IP and RS485	149B	Bi-directional high-speed communication using Modbus protocol over Ethernet network (IP)	Easy and high-speed connection by ethernet line to a building management system. Allows access to multiple unit parameters	30RQM/30RQP 160-520
Energy Management Module	156	EMM Control board with additional inputs/outputs. See Energy Management Module option chapter	Extended remote control capabilities (Set-point reset, ice storage end, demand limits, boiler on/off command...)	30RQM/30RQP 160-520
Input contact for Refrigerant leak detection	159	0-10 V signal to report any refrigerant leakage in the unit directly on the controller (the leak detector itself must be supplied by the customer)	Immediate customer notification of refrigerant losses to the atmosphere, allowing timely corrective actions	30RQM/RQP 160-520
Compliance with Russian regulations	199	EAC certification	Compliance with Russian regulations	30RQM/30RQP 160-520
Compliance with Australian regulations	200	Unit approved to Australian code	Compliance with Australian regulations	30RQM/30RQP 160-520
Power factor correction	231	Capacitors for automatic regulation of power factor (cos phi) value to 0,95.	Reduction of the apparent electrical power, compliance with minimum power factor limit set by utilities	30RQM/30RQP 160-520
Coil defrost resistance heaters	252	Electric heaters under the coils and the condensate pans	Prevents frost formation on the coils; compulsory in the heating mode, if the outdoor is below 0°C	30RQM/30RQP 160-520
Welded evaporator connection kit	266	Victaulic piping connections with welded joints	Easy installation	30RQM/30RQP 160-520
230 V electric plug	284	230 VAC power supply source provided with plug socket and transformer (180 VA, 0.8 A)	Permits connection of a laptop or an electrical device during unit commissioning or servicing	30RQM/30RQP 160-520
Expansion vessel	293	6-bar expansion tank integrated into the hydraulic module (option 116 required)	Easy and fast installation (plug & play), & Protection of closed water systems from excessive pressure	30RQM/30RQP 160-520
Screwed water connection sleeve kit for DSH	303	DSH connections with screw connection sleeves	Easy installation. Allows unit connection to a screw connector	30RQM/30RQP 160-520
Welded water connection kit for DSH	304	DSH inlet/outlet welded connection sleeves	Easy installation	30RQM/30RQP 160-520
Set-point adjustment by 4-20 mA signal	311	Connections enabling a 4-20 mA signal input	Easy energy management, allow to adjust set-point by a 4-20mA external signal	30RQM/30RQP 160-520

BRINE OPTIONS (OPTION 6B)

Brine production from 0°C to -8°C is only possible with the low-temperature brine option 6B, available on sizes 30RQP 180-230-270-310 only.

The unit is equipped with insulation on the intake tubes. The insulation is reinforced on the low-temperature brine solution option.

The operating range depends on:

- the unit size,
- the glycol type,
- its concentration,
- the flow rate,
- the temperature of the glycol solution,
- the condensing pressure (ambient temperature).

UNITS WITH FANS WITH AVAILABLE PRESSURE FOR INDOOR INSTALLATION (OPTION 12 - STATIC HIGH PRESSURE FAN)

This option applies to 30RQP 160-520 units installed inside the building in a plant room.

For this type of installation, the cold or hot air leaving the air heat exchangers is discharged by the fans to the outside of the building, using a duct system that causes a pressure drop in the air path.

Therefore, this option features more powerful fan motors than those fitted to standard units.

For each installation, the duct pressure drops differ, depending on the duct length, the duct section and the direction changes.

30RQP units with option 12 are designed to operate with air discharge ducts with maximum pressure drop of 200 Pa (units are equipped with variable-speed fans with a maximum speed of 19 r/s, instead of 15.8 r/s for standard units).

Use of variable speed up to 19 r/s can overcome the duct pressure drop while maintaining an optimized air flow per circuit. All fans in the same circuit, operating at the same time, have the same speed.

The fan power input for fans with a speed of 19 r/s is increased compared to that of standard fans with a speed of 15.8 r/s (the multiplier coefficient is the same as the cube of the speed ratio, i.e. x 1.72).

In the cooling / heating mode, the full-load or part-load speed is controlled by a patented algorithm that permanently optimizes the condensing / evaporating temperature to ensure the best unit energy efficiency (EER / COP) whatever the operating conditions and pressure drop of the system ductwork.

If necessary for a specific installation, the maximum fan speed of 30RQP unit can be fixed between 13.3 and 19 r/s, using the

Service Configuration menu. Consult the 30RQM/RQP Smart View Control manual for this modification.

The maximum configured speed applies to both the cooling and heating modes.

The performances (capacities, efficiencies) depend on the speed of the fans, then on the duct pressure drop:

- between 0 and 100 Pa, the unit performances are only slightly affected
- between 100 and 200 Pa, the unit performances may vary considerably, depending on the operating conditions (outdoor air temperature and water conditions)

The noise level into the ductwork and radiated around the unit is also related to the pressure drop.

Please refer to the Carrier Electronic catalogue to evaluate the impact of the estimated duct system on the 30RQP unit operating conditions.

Nominal and maximum air flows per circuit (A and B) for 30RQP sizes

30RQP	Circuit A Nominal/maximum air flow (l/s)	Circuit B Nominal/maximum air flow (l/s)
160	4514 / 5417	9028 / 10833
180-230	9028 / 10833	9028 / 10833
240-270	9028 / 10883	13542 / 16250
310-330	9028 / 10883	18056 / 21667
380	13542 / 16250	18056 / 21667
430-520	18056 / 21667	18056 / 21667

Principle of the installation of the ducts

Solution 1

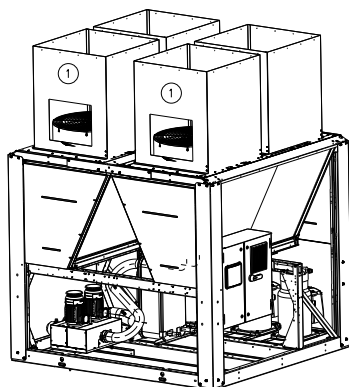

Solution 2

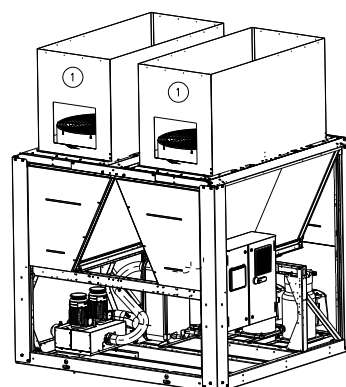

1. Fan motor access hatches (provide a 700 x 700 mm hatch) for each single and dual duct

PARTIAL HEAT RECOVERY USING DESUPERHEATERS (OPTION 49)

This option permits the production of free hot water using heat reclaim by desuperheating the compressor discharge gases. The option is available for the whole 30RQM/30RQP range.

A plate heat exchanger is installed as standard, with the air heat exchanger coils on the compressor discharge line of each circuit.

Physical data, 30RQM/30RQP units with partial heat reclaim

30RQM/30RQP	160	180	210	230	240	270	310	330	380	430	470	520	
Desuperheater in circuits A/B	Plate heat exchanger												
Water volume circuit A/B	2/ 3,75	2/ 3,75	3,75/ 3,75	3,75/ 3,75	3,75/ 3,75	3,75/ 5,5	3,75/ 5,5	3,75/ 7,5	5,5/ 7,5	7,5/ 7,5	7,5/ 7,5	7,5/ 7,5	
Max, water-side operating pressure	1000	1000	1000	1000	1000	1000	1000	1000	1000	1000	1000	1000	
Refrigerant⁽¹⁾	Vicalic												
Circuit A charge	kg	16,0	22,2	23,7	25,5	29,2	29,2	32,8	36,8	46,2	55,2	56,7	59,2
	teqCO ₂	33,4	46,4	49,5	53,2	61,0	61,0	68,5	76,8	96,5	115,3	118,4	123,6
Circuit B charge	kg	23,7	23,7	23,7	25,5	37,1	38,5	49,7	55,2	55,2	55,2	56,7	59,2
	teqCO ₂	49,5	49,5	49,5	53,2	77,5	80,4	103,8	115,3	115,3	115,3	118,4	123,6
Water connections	Vicalic												
Connection	inch	2	2	2	2	2	2	2	2	2	2	2	
External diameter	mm	60,3	60,3	60,3	60,3	60,3	60,3	60,3	60,3	60,3	60,3	60,3	
30RQM													
Operating weight⁽¹⁾													
Standard unit + desuperheater option	kg	1472	1537	1681	1704	2112	2270	2390	2625	3099	3365	3377	3417
Unit with options 15 and desuperheater	kg	1555	1620	1789	1812	2220	2396	2516	2769	3261	3545	3557	3598
Standard unit + option 15 + option 116S + option desuperheater	kg	1695	1760	1941	1963	2381	2605	2734	2974	3506	3791	3839	3879
30RQP													
Operating weight⁽¹⁾													
Standard unit + desuperheater option	kg	1508	1574	1717	1740	2149	2307	2426	2662	3135	3422	3434	3484
Unit with options 15 and desuperheater	kg	1591	1657	1825	1848	2257	2432	2552	2806	3297	3602	3615	3664
Standard unit + option 15 + option 116S + option desuperheater	kg	1731	1797	1977	1999	2417	2641	2770	3011	3543	3848	3897	3945

(1) Weights shown are a guideline only.

Performance available on ECAT Electronic catalogue

HYDRAULIC MODULE (OPTION 116)

The new generation of Carrier hydraulic module saves a lot of installation time. The heat pump is factory-equipped with the main components for the hydraulic system: Water pump, electronic flow switch, Victaulic screen filter, pressure transducers, water temperature sensors, pressures taps (2), relief valve, drain valve, air vent, water purge, optional hydraulic module heater and optional expansion tank.

The pressure transducers allow the control to:

- Display the available pressure at the unit outlet and the static system pressure
- Calculate the instantaneous flow rate, using an algorithm that integrates the unit characteristics
- Integrate the system and water pump protection devices (lack of water, water pressure, water flow rate, etc.).

On units fitted with Greenspeed® variable-speed pump, the user display enables to:

- Adjust the required pump speed
- Adjust the required available pressure at the unit outlet and the static system pressure, to real customer needs thus saving energy: no need any more for a water flow control valve used for creating artificial pressure drops that are wasting energy.

Several water pump types are available to suit any application:

- Single or dual low-pressure pump or single or dual high-pressure pump
- Greenspeed® variable-speed single or dual high-pressure pump.

If necessary, increased frost protection down to -20 °C is possible by adding the heater option to the hydraulic module piping (see options 42A).

The hydraulic module option is integrated into the heat pump without increasing its dimensions and saves the space normally used for the water pump.

Typical hydraulic circuit diagram

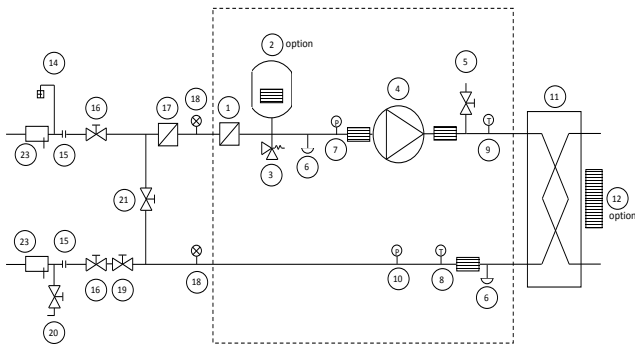

Hydraulic module



Key

Components of the unit and hydraulic module:

1. Screen filter (mesh opening 1.2 mm)
2. Expansion tank (option)
3. Relief valve
4. Available pressure pump (single pump or dual pump)
5. Air purge
6. Water drain valve
7. Pressure sensor
Note: Gives pump suction pressure information
8. Temperature probe -
Note: Gives heat exchanger leaving temperature information
9. Temperature probe -
Note: Gives heat exchanger entering temperature information
10. Pressure sensor
Note: Gives unit leaving pressure information
11. Plate heat exchanger
12. Evaporator frost protection heater (option)

Installation components

14. Air purge
15. Flexible connection
16. Shut-off valve
17. Screen filter (obligatory for a unit without hydraulic module)
18. Pressure gauge
19. Water flow control valve
Note: Not necessary for a hydraulic module with a variable-speed pump
20. Charge valve
21. Frost protection bypass valve (when shut-off valves [16] are closed during winter)
23. Temperature probe well
- Hydraulic module (unit with hydraulic module)

Notes:

- The installation must be protected against frost.
- The hydraulic module and unit evaporator are protected (option 42A, factory installed) against frost with electric heaters (item 12 + ).
- The pressure sensors are installed at connections without Schraeder valves. Depressurise and drain the system before any intervention.

Electrical data, units with hydraulic modules

The pumps that are factory installed in these units are eco-design compliant 2015 (EU regulation N°547/2012 for pumps) and have motors with efficiency class IE3. The additional electrical data required by regulation 640/2009 is given in the installation, operation and maintenance manual.

This regulation concerns the application of directive 2009/125/EC on the eco-design requirements for electric motors.

VARIABLE WATER FLOW SYSTEM (VWF) 30RQM/30RQP 160-520

Carrier Variable Water Flow

Recommended by Carrier, the AquaSnap® can be equipped with one or two variable-speed pumps to save significant pumping energy costs (more than two-thirds), ensure tighter water flow rate control, and improve overall system reliability.



Carrier Variable Water Flow (VWF) is a hydraulic control function package that controls the water flow rate.

Carrier VWF not only ensures control at full load, a specific Carrier algorithm linked to an electronic frequency converter also continuously modulates the flow rate to minimise pump consumption at full load as well as part load.

The Carrier hydraulic module includes pressure transducers that permit intelligent measurement of the water flow rate and real-time display on the or Smart View user interface. All adjustments can be made directly on the interface, speeding up start-up and maintenance.

As Carrier VWF acts directly on the pump, the system no longer requires the control valve at the unit outlet. However, for applications with two-way valves a bypass system must be kept to guarantee the minimum flow rate.

Operating principle

■ Full-load set-point

The flow rate at full load is controlled by the interface, which reduces the pump speed. This first control saves energy that would normally be dissipated in the control valve. For example, if the pressure supplied by the pump is reduced by 20%, the energy consumption of the pump is reduced by the same ratio, compared to a conventional installation.



■ Operating mode at part load

Smart View includes three part-load operating modes:

- Fixed speed control
- Constant delta P control
- Constant delta T control.

1 - Fixed speed

The control continuously ensures a constant pump speed based on compressor capacity.

When the compressor capacity is equal to zero, the pump speed can be automatically reduced to a second set-point (adjustable down to 60%) to save energy during low occupancy periods.

This solution is suitable for traditional installations with constant water flow and terminal units equipped with three-way valves. This solution reduces pumping energy costs especially when the flow can be reduced during night-time periods.

2 - Constant delta P control

The control continuously acts on the pump speed to ensure a constant delta P.

This solution is suitable for installations with two-way valves. When these close, the water speed will accelerate in the system branches that are still open. For a fixed-speed pump this results in an unnecessary increase of the pressure at the pump outlet.

The constant delta P control mode ensures that each circuit branch always has a uniform supply, without unnecessary energy waste.

In industrial processes such as plastic injection moulding, this solution ensures that each terminal unit has the correct pressure supply.

3 - Constant delta T control

The VWF algorithm maintains a constant delta T no matter what the unit load, reducing the flow rate to the minimum. It is suitable for the majority of comfort applications.

PHYSICAL DATA. SIZES 160 TO 520

30RQM			160	180	210	230	240	270	310	330	380	430	470	520	
Heating															
Standard unit Full load performances*	HA1	Nominal capacity	kW	181	198	240	216	272	294	342	359	415	474	457	436
		COP	kW/kW	3,75	3,79	3,81	3,56	3,86	3,75	3,74	3,82	3,72	3,72	3,62	3,57
	HA2	Nominal capacity	kW	174	191	232	245	262	282	329	345	399	456	498	537
		COP	kW/kW	2,99	3,05	3,04	2,91	3,11	2,96	2,98	3,04	2,95	2,97	2,95	2,94
Standard unit Seasonal energy efficiency**	HA1	SCOP _{30/35°C}	kWh/kWh	3,20	3,21	3,23	3,21	3,20	3,22	3,20	3,20	3,30	3,35	3,35	3,32
		ηs heat _{30/35°C}	%	125	125	126	125	125	126	125	125	129	131	131	130
		P _{rated}	kW	121	134	159	169	159	194	211	231	268	305	339	356
Cooling															
Standard unit Full load performances*	CA1	Nominal capacity	kW	154	168	201	225	232	264	297	322	372	424	458	510
		EER	kW/kW	2,76	2,87	2,73	2,74	2,89	2,86	2,86	2,87	2,87	2,90	2,75	2,74
		Eurovent class		C	C	C	C	C	C	C	C	C	B	C	C
Standard unit Seasonal energy efficiency**	CA1	SEER _{12/7°C} Comfort low temp.	kWh/kWh	3,89	3,89	3,93	3,99	3,95	4,03	4,06	4,00	4,04	4,11	4,09	4,04
		SEPR _{12/7°C} Process high temp.	kWh/kWh	4,40	4,31	4,41	4,12	4,64	4,77	4,72	5,09	5,03	4,86	4,78	4,58
Sound levels															
Standard unit															
Sound power level ⁽¹⁾			dB(A)	90	91	91	91	92	92	93	93	94	94	94	94
Sound pressure level at 10 m ⁽²⁾			dB(A)	58	59	59	59	60	60	61	61	62	62	62	62
Standard unit + option 15⁽³⁾															
Sound power level ⁽¹⁾			dB(A)	89	90	90	90	91	91	91	92	92	93	93	93
Sound pressure level at 10 m ⁽²⁾			dB(A)	57	58	58	58	59	59	59	60	60	61	61	61
Dimensions															
Length			mm	2410	2410	2410	2410	3604	3604	3604	3604	4797	4797	4797	4797
Width			mm	2322	2322	2322	2322	2322	2322	2322	2322	2322	2322	2322	2322
Height			mm	2297	2297	2297	2297	2297	2297	2297	2297	2297	2297	2297	2297
Operating weight⁽⁴⁾															
Standard unit			kg	1415	1490	1618	1641	2049	2197	2318	2548	3013	3274	3286	3327
Standard unit + option 15/15LS			kg	1497	1572	1726	1749	2157	2323	2444	2693	3175	3454	3466	3507
Standard unit + option 15/15LS + option 116W ⁽³⁾			kg	1637	1712	1878	1900	2318	2531	2662	2897	3380	3700	3748	3788
Unit + option 15 + option 116W + Water buffer tank option			kg	2585	2656	2821	2844	3257	3471	3598	3833	4312	4643	4692	4732
Compressors															
Hermetic Scroll 48,3 r/s															
Circuit A				1	1	2	2	2	2	2	2	3	4	4	4
Circuit B				2	2	2	2	2	3	3	4	4	4	4	4
No. of control stages				3	3	4	4	4	5	5	6	7	8	8	8

- * In accordance with standard EN14511-3:2013.
 ** In accordance with standard EN14825:2016, average climate
 HA1 Heating mode conditions: Water heat exchanger water entering/leaving temperature 30°C/35°C, outside air temperature tdb/twb = 7°C db/6°C wb, evaporator fouling factor 0 m².K/W
 HA2 Heating mode conditions: Water heat exchanger water entering/leaving temperature 40°C/45°C, outside air temperature tdb/twb = 7°C db/6°C wb, evaporator fouling factor 0 m².K/W
 CA1 Cooling mode conditions: Evaporator water entering/leaving temperature 12°C/7°C, outside air temperature 35°C, evaporator fouling factor 0 m².K/W
ηs heat_{30/35°C} & SCOP_{30/35°C} **SEER_{12/7°C} & SEPR_{12/7°C}** **Values calculated in accordance with EN14825:2016**
 (1) In dB ref=10⁻¹² W. (A) weighting. Declared dual number noise emission values in accordance with ISO 4871 (with an associated uncertainty of +/-3 dB(A)). Measured in accordance with ISO 9614-1 and certified by Eurovent at nominal conditions EN14511 - cooling mode.
 (2) In dB ref 20 μPa. (A) weighting. Declared dual number noise emission values in accordance with ISO 4871 (with an associated uncertainty of +/-3 dB(A)). For information. calculated from the sound power level Lw(A).
 (3) Options: 15 = Low noise level. 116S = High Pressure dual-pump hydraulic module
 (4) Weights are guidelines only. Refer to the unit nameplate.



Eurovent certified values

PHYSICAL DATA. SIZES 160 TO 520

30RQM		160	180	210	230	240	270	310	330	380	430	470	520
Refrigerant⁽⁴⁾		R410A											
Circuit A charge	kg	14,5	22,0	23,0	24,0	27,0	27,0	30,0	33,0	42,0	53,0	54,0	56,0
	teqCO ₂	30,3	45,9	48,0	50,1	56,4	56,4	62,6	68,9	87,7	110,7	112,8	116,9
Circuit B charge	kg	23,0	23,0	23,0	24,0	35,0	36,0	48,5	53,0	53,0	53,0	54,0	56,0
	teqCO ₂	48,0	48,0	48,0	50,1	73,1	75,2	101,3	110,7	110,7	110,7	112,8	116,9
Capacity control		Smart View Control											
Minimum capacity	%	33%	33%	25%	25%	25%	20%	20%	17%	14%	13%	13%	13%
Air heat exchangers		Grooved copper tubes and aluminium fins											
Fans		Axial Flying Bird 4 with rotating shroud											
Quantity		3	4	4	4	5	5	6	6	7	8	8	8
Maximum total air flow	l/s	13542	18056	18056	18056	22569	22569	27083	27083	31597	36111	36111	36111
Maximum rotation speed	r/s	16	16	16	16	16	16	16	16	16	16	16	16
Water heat exchanger		Dual-circuit plate heat exchanger											
Water content	l	15	15	15	19	27	27	35	44	44	44	47	53
Max. water-side operating pressure without hydraulic module	kPa	1000	1000	1000	1000	1000	1000	1000	1000	1000	1000	1000	1000
Hydraulic Module (option)		Pump. Victaulic screen filter. relief valve. water valve and air purge. pressure sensors. expansion tank (option)											
Pump		Centrifugal. monocell. 48,3 r/s. low or high pressure (as required). single or dual pump (as required)											
Expansion vessel volume	l	50	50	50	50	80	80	80	80	80	80	80	80
Max. water-side operating pressure with hydraulic module	kPa	400	400	400	400	400	400	400	400	400	400	400	400
Water connections with or without hydraulic module		Victaulic type											
Diameter	inch	3	3	3	3	4	4	4	4	4	4	4	4
External diameter	mm	88,9	88,9	88,9	88,9	114,3	114,3	114,3	114,3	114,3	114,3	114,3	114,3
Chassis paint colour		Colour code RAL 7035											

(4) Weights are guidelines only. Refer to the unit nameplate.

PHYSICAL DATA, SIZES 160 TO 520

30RQP			160	180	210	230	240	270	310	330	380	430	470	520	
Heating															
Standard unit Full load performances*	HA1	Nominal capacity	kW	181	198	240	216	272	294	342	359	415	474	457	436
		COP	kW/kW	3,75	3,79	3,81	3,56	3,86	3,75	3,74	3,82	3,72	3,72	3,62	3,57
	HA2	Nominal capacity	kW	174	191	232	245	262	282	329	345	399	456	498	537
		COP	kW/kW	2,99	3,05	3,04	2,91	3,11	2,96	2,98	3,04	2,95	2,97	2,95	2,94
Standard unit Seasonal energy efficiency**	HA1	SCOP _{30/35°C}	kWh/kWh	3,38	3,38	3,39	3,39	3,38	3,39	3,41	3,40	3,43	3,46	3,47	3,41
		η _{s heat} _{30/35°C}	%	132	132	133	133	132	132	133	133	134	135	136	134
		P _{rated}	kW	121	134	159	169	159	194	211	231	268	305	339	356
Cooling															
Standard unit Full load performances*	CA1	Nominal capacity	kW	154	168	201	225	232	264	297	322	372	424	458	510
		EER	kW/kW	2,76	2,87	2,73	2,74	2,89	2,86	2,86	2,87	2,87	2,90	2,75	2,74
		Eurovent class		C	C	C	C	C	C	C	C	C	B	C	C
Standard unit Seasonal energy efficiency**		SEER _{12/7°C} Comfort low temp.	kWh/kWh	4,07	4,08	4,09	4,13	4,16	4,21	4,16	4,23	4,32	4,33	4,30	4,22
		SEPR _{12/7°C} Process high temp.	kWh/kWh	5,24	5,29	5,29	5,16	5,13	5,39	5,52	5,45	5,56	5,63	5,40	5,18
Unit + option 6 Seasonal energy efficiency**		SEPR _{-2/-8°C} Process medium temp.***	kWh/kWh	NA	3,55	NA	3,47	NA	3,36	3,67	NA	NA	NA	NA	NA
Sound levels															
Standard unit															
		Sound power level ⁽¹⁾	dB(A)	90	91	91	91	92	92	93	93	94	94	94	94
		Sound pressure level at 10 m ⁽²⁾	dB(A)	58	59	59	59	60	60	61	61	62	62	62	62
Standard unit + option 15⁽³⁾															
		Sound power level ⁽¹⁾	dB(A)	89	90	90	90	91	91	91	92	92	93	93	93
		Sound pressure level at 10 m ⁽²⁾	dB(A)	57	58	58	58	59	59	59	60	60	61	61	61
Standard unit + option 15LS⁽³⁾															
		Sound power level ⁽¹⁾	dB(A)	84	85	86	86	86	87	87	87	88	89	89	89
		Sound pressure level at 10 m ⁽²⁾	dB(A)	52	53	54	54	54	55	55	55	56	57	57	57
Dimensions															
		Length	mm	2410	2410	2410	2410	3604	3604	3604	3604	4797	4797	4797	4797
		Width	mm	2322	2322	2322	2322	2322	2322	2322	2322	2322	2322	2322	2322
		Height	mm	2297	2297	2297	2297	2297	2297	2297	2297	2297	2297	2297	2297
Operating weight⁽⁴⁾															
		Standard unit	kg	1450	1526	1654	1677	2085	2233	2355	2585	3050	3331	3343	3393
		Standard unit + option 15/15LS	kg	1533	1609	1762	1785	2193	2359	2481	2729	3212	3512	3524	3573
		Standard unit + option 15/15LS + option 116W ⁽³⁾	kg	1673	1749	1914	1936	2354	2568	2699	2934	3416	3757	3806	3854
		Unit + option 15 + option 116W + Water buffer tank option	kg	2632	2708	2873	2895	3313	3527	3658	3893	4375	4716	4765	4813
Compressors															
				Hermetic Scroll 48.3 r/s											
		Circuit A		1	1	2	2	2	2	2	2	3	4	4	4
		Circuit B		2	2	2	2	2	3	3	4	4	4	4	4
		No. of control stages		3	3	4	4	4	5	5	6	7	8	8	8

* In accordance with standard EN14511-3:2013.

** In accordance with standard EN14825:2016, average climate

*** With EG 30%

HA1 Heating mode conditions: Water heat exchanger water entering/leaving temperature 30°C/35°C, outside air temperature tdb/twb = 7°C db/6°C wb, evaporator fouling factor 0 m².K/W

HA2 Heating mode conditions: Water heat exchanger water entering/leaving temperature 40°C/45°C, outside air temperature tdb/twb = 7°C db/6°C wb, evaporator fouling factor 0 m².K/W

CA1 Cooling mode conditions: Evaporator water entering/leaving temperature 12°C/7°C, outside air temperature 35°C, evaporator fouling factor 0 m².K/W

η_{s heat}_{30/35°C} & SCOP_{30/35°C} Bold values compliant to Ecodesign regulation: (EU) No 813/2013 for Heat Pump application

SEER_{12/7°C} & SEPR_{12/7°C} Values calculated in accordance with EN14825:2016

SEPR_{-2/-8°C} Bold values compliant to Ecodesign regulation: (EU) No 2015/1095 for Process application

NA Non Authorized for the specific application for CEE market

(1) In dB ref=10-12 W. (A) weighting. Declared dual number noise emission values in accordance with ISO 4871 (with an associated uncertainty of +/-3 dB(A)). Measured in accordance with ISO 9614-1 and certified by Eurovent at nominal conditions EN14511 - cooling mode.

(2) In dB ref 20 μPa. (A) weighting. Declared dual number noise emission values in accordance with ISO 4871 (with an associated uncertainty of +/-3 dB(A)). For information, calculated from the sound power level Lw(A).

(3) Options: 15 = Low noise level. 116S = High Pressure dual-pump hydraulic module

(4) Weights are guidelines only. Refer to the unit nameplate.



Eurovent certified values

PHYSICAL DATA, SIZES 160 TO 520

30RQP	160	180	210	230	240	270	310	330	380	430	470	520	
Refrigerant⁽⁴⁾	R410A												
Circuit A charge	kg	14,5	22,0	23,0	24,0	27,0	27,0	30,0	33,0	42,0	53,0	54,0	56,0
	teqCO ₂	30,3	45,9	48,0	50,1	56,4	56,4	62,6	68,9	87,7	110,7	112,8	116,9
Circuit B charge	kg	23,0	23,0	23,0	24,0	35,0	36,0	48,5	53,0	53,0	53,0	54,0	56,0
	teqCO ₂	48,0	48,0	48,0	50,1	73,1	75,2	101,3	110,7	110,7	110,7	112,8	116,9
Capacity control	Smart View Control												
Minimum capacity	%	33%	33%	25%	25%	25%	20%	20%	17%	14%	13%	13%	13%
Air heat exchangers	Grooved copper tubes and aluminium fins												
Fans	Axial Flying Bird 4 with rotating shroud												
Quantity		3	4	4	4	5	5	6	6	7	8	8	8
Maximum total air flow	l/s	13542	18056	18056	18056	22569	22569	27083	27083	31597	36111	36111	36111
Maximum rotation speed	r/s	16	16	16	16	16	16	16	16	16	16	16	16
Water heat exchanger	Dual-circuit plate heat exchanger												
Water content	l	15	15	15	19	27	27	35	44	44	44	47	53
Max. water-side operating pressure without hydraulic module	kPa	1000	1000	1000	1000	1000	1000	1000	1000	1000	1000	1000	1000
Hydraulic Module (option)	Pump, Victaulic screen filter, relief valve, water valve and air purge, pressure sensors, expansion tank (option)												
Pump	Centrifugal, monocell, 48,3 r/s, low or high pressure (as required), single or dual pump(as required)												
Expansion vessel volume	l	50	50	50	50	80	80	80	80	80	80	80	80
Max. water-side operating pressure with hydraulic module	kPa	400	400	400	400	400	400	400	400	400	400	400	400
Water connections with or without hydraulic module													
Diameter	inch	3	3	3	3	4	4	4	4	4	4	4	4
External diameter	mm	88,9	88,9	88,9	88,9	114,3	114,3	114,3	114,3	114,3	114,3	114,3	114,3
Chassis paint colour	Colour code RAL 7035												

(4) Weights are guidelines only. Refer to the unit nameplate.

ELECTRICAL DATA

30RQM		160	180	210	230	240	270	310	330	380	430	470	520
Power circuit													
Nominal power supply	V-ph-Hz	400 - 3 -50											
Voltage range	V	360 - 440											
Control circuit supply													
24 V via internal transformer													
Nominal unit current draw ⁽¹⁾													
Circuit A&B	A	100	110	133	147	151	166	191	199	233	266	294	322
Maximum unit power input ⁽²⁾													
Circuit A&B	kW	80	88	107	118	120	134	152	161	188	215	236	258
Cosine Phi unit at maximum power ⁽²⁾													
		0,88	0,87	0,88	0,88	0,87	0,88	0,87	0,88	0,88	0,88	0,88	0,88
Maximum unit current draw (Un-10%) ⁽³⁾													
Circuit A&B	A	144	158	192	211	215	241	273	289	337	385	422	460
Maximum unit current draw (Un) ⁽⁴⁾													
Circuit A&B - Standard Unit	A	133	146	177	195	199	222	252	266	310	354	390	425
Circuit A&B - Unit with option 231	A	100	110	133	148	151	166	192	200	233	266	296	326
Maximum start-up current, standard unit (Un) ⁽⁵⁾													
Circuit A&B	A	307	356	352	406	409	396	462	440	485	529	600	636
Max. start-up current, unit with soft starter (Un) ⁽⁵⁾													
Circuit A&B	A	261	283	305	332	336	350	389	394	438	482	527	562

- (1) Conditions equivalent to the standardised Eurovent conditions (evaporator water input-output temperature = 12 °C/7 °C, outside air temperature = 35 °C)
(2) Power input, compressors and fans, at the unit operating limits (saturated suction temperature 15 °C, saturated condensing temperature 68.3 °C) and nominal voltage of 400 V (data given on the unit nameplate).
(3) Maximum unit operating current at maximum unit power input and at 360 V.
(4) Maximum unit operating current at maximum unit power input and at 400 V (values given on the unit nameplate).
(5) Maximum instantaneous starting current at operating limits (maximum operating current of the smallest compressor(s) + current of the fan(s) + locked rotor current of the largest compressor).
Fan motor electrical data reported upstream the variable speed drive at Eurovent equivalent conditions and motor ambient air temperature of 50 °C at 400 V:
Current 3.8 A; Start-up current 20 A; Power input: 1.75 kW.

30RQP		160	180	210	230	240	270	310	330	380	430	470	520
Power circuit													
Nominal power supply	V-ph-Hz	400 - 3 -50											
Voltage range	V	360 - 440											
Control circuit supply													
24 V via internal transformer													
Nominal unit current draw ⁽¹⁾													
Circuit A&B	A	97	107	130	144	147	162	186	195	227	260	288	316
Maximum unit power input ⁽²⁾													
Circuit A&B	kW	81	88	108	118	120	134	153	161	188	215	237	259
Cosine Phi unit at maximum power ⁽²⁾													
		0,88	0,88	0,88	0,88	0,88	0,88	0,88	0,88	0,88	0,88	0,88	0,88
Maximum unit current draw (Un-10%) ⁽³⁾													
Circuit A&B	A	142	154	189	208	211	237	268	284	331	378	416	454
Maximum unit current draw (Un) ⁽⁴⁾													
Circuit A&B - Standard Unit	A	131	142	174	192	195	218	247	261	305	348	383	419
Circuit A&B - Unit with option 231	A	98	108	131	146	148	164	188	197	230	262	291	321
Maximum start-up current, standard unit (Un) ⁽⁵⁾													
Circuit A&B	A	305	353	349	402	405	392	458	436	479	523	594	629
Max. start-up current, unit with soft starter (Un) ⁽⁵⁾													
Circuit A&B	A	259	279	302	329	332	346	384	389	433	476	520	556

- (1) Conditions equivalent to the standardised Eurovent conditions (evaporator water input-output temperature = 12 °C/7 °C, outside air temperature = 35 °C)
(2) Power input, compressors and fans, at the unit operating limits (saturated suction temperature 15 °C, saturated condensing temperature 68.3 °C) and nominal voltage of 400 V (data given on the unit nameplate).
(3) Maximum unit operating current at maximum unit power input and at 360 V.
(4) Maximum unit operating current at maximum unit power input and at 400 V (values given on the unit nameplate).
(5) Maximum instantaneous starting current at operating limits (maximum operating current of the smallest compressor(s) + current of the fan(s) + locked rotor current of the largest compressor).
Fan motor electrical data reported upstream the variable speed drive at Eurovent equivalent conditions and motor ambient air temperature of 50 °C at 400 V:
Current 3.8 A; Start-up current 20 A; Power input: 1.75 kW.

ELECTRICAL DATA

Short-circuit stability current (TN system)⁽¹⁾

30RQM/30RQP		160	180	210	230	240	270	310	330	380	430	470	520
Short-time assigned current I_{cw} (1s) rms value/peak I_{pk}(¹)													
Circuits A & B	kA/kA	8/30	8/30	8/30	8/30	8/30	8/30	15/65	15/65	15/65	15/65	20/80	20/80
With fuses upstream - maximum fuse values assigned (gL/gG)													
Circuits A & B	A	200	200	200	250	250	250	315	315	400	400	630	630
With fuses upstream – assigned conditional short-circuit current I_{cc}/I_{cf}													
Circuits A & B	kA	50	50	50	50	50	50	50	50	50	50	50	50

(1) Type of system earthing

IT system: The short circuit current stability values given above for the TN system are not valid for IT, modifications are required.

Electrical data notes for 30RQM/30RQP units:

- 30RQM/30RQP units have a single power connection point located immediately upstream of the main switch.
- Control box includes:
 - Main disconnect switch,
 - Start-up and motor protection devices for each compressor, fans and pumps,
 - Control devices.
- Field connections:

All connections to the system and the electrical installations must be in accordance with all applicable codes.
- The Carrier 30RQM/30RQP units are designed and built to ensure conformance with these codes. The recommendations of European standard EN 60204-1 (corresponds to IEC 60204-1) (machine safety - electrical machine components - part 1: General regulations) are specifically taken into account, when designing the electrical equipment.

Notes

- Generally the recommendations of IEC 60364 are accepted as compliance with the requirements of the installation regulation.
- Conformance with EN 60204-1 is the best means of ensuring compliance (§1.5.1) with the Machinery Directive.
- Appendix B of standard EN 60204-1 specifies the electrical features used for the operation of the machines.
- The operating conditions of 30RQM/30RQP units are described below:
 1. Physical environment⁽¹⁾

The classification of environment is specified in standard EN 60364:

 - Outdoor installation⁽¹⁾,
 - Ambient temperature range: Minimum temperature -20 °C up to +48 °C⁽²⁾, Altitude: AC1 Lower than or equal to 2000 m (for the hydraulic module, see paragraph 4.7 in the IOM),
 - Presence of hard solid: Class AE3 (no significant dust present)⁽¹⁾,
 - Presence of corrosive and polluting substances, class AF1 (negligible),
 - Competence of personnel: BA4 (informed personnel).
 2. Compatibility for low-frequency conducted disturbances according to class 2 levels per IEC61000-2-4 standard:
 - Power supply frequency variation : +2Hz
 - Phase imbalance : 2%
 - Total Voltage Harmonic Distortion (THDV) : 8%
 3. The neutral (N) line must not be connected directly to the unit (if necessary use a transformer).
 4. Overcurrent protection of the power supply conductors is not provided with the unit.
 5. The factory-installed disconnect switch(es)/circuit breaker(s) are of a type suitable for power interruption in accordance with EN 60947-3 (corresponds to IEC 60947-3).

6. The units are designed for connection to TN networks (IEC 60364). In IT networks the use of noise filters integrated into the variable frequency drive(s) make machine use unsuitable. In addition, the equipment characteristics in case of insulation failure are modified. Provide a local earth; contact competent local organisations to have the electrical installation completed. 30RQM/30RQP models are designed for use in domestic/residential and industrial environments: those not equipped with variable frequency drive(s) comply with the standards below.

- 61000-6-3: Generic standard - Emission standard for residential, commercial and light-industrial environments,
- 61000-6-2: Generic standard - Immunity for industrial environments. Machines that are equipped with variable frequency drive(s) (RQP, options: 28, 116V, 116W) comply with standard EN61800 - 3 "Adjustable speed electrical power drive systems - Part 3: EMC requirements and specific test methods" for the following classifications:
 - Use in the first and second environments⁽³⁾.
 - Category C2 applicable in the first environment to stationary devices designed to be installed and commissioned by a professional only.

Warning: In a residential environment, this product may cause radio interference in which case additional mitigation measures could be required.

- Leakage currents: If protection by monitoring the leakage currents is necessary to ensure the safety of the installation, the presence of additional leakage currents introduced by the use of variable frequency drive(s) in the unit must be considered.

In particular these protection devices shall be of reinforced immunity types and have a threshold not lower than 150 mA.

- Capacitors that are integrated as part of the option 231 can generate electrical disturbances in the installation the unit is connected to. Presence of these capacitors must be considered during the electrical study prior to the start-up.

Note: If particular aspects of an actual installation do not conform to the conditions described above, or if there are other conditions which should be considered, always contact your local Carrier representative.

- (1) The required protection level for this class is IP43BW (according to reference document IEC 60529). All 30RQM/30RQP units are IP44CW and fulfil this protection condition.
- (2) The maximum ambient temperature allowed for machines equipped with option 231 is +40°C
- (3) - Example of installations included in the first environment: commercial and residential buildings.
 - Example of installations included in the second environment: industrial zones, technical locations supplied from a dedicated transformer.

OPERATING LIMITS

Heat exchanger water flow rate

30RQM/30RQP 160-520 without hydraulic module

	Minimum flow rate (l/s) ⁽¹⁾	Maximum flow rate (l/s) ⁽²⁾
160	2,9	17,5
180	3,1	17,5
210	3,8	17,5
230	4,1	21,8
240	4,2	29,8
270	4,8	29,8
310	5,5	35,2
330	5,8	40,4
380	6,7	40,4
430	7,8	40,4
470	8,4	41,6
520	9,2	43,4

- (1) Minimum flow rate for the conditions of permissible maximum water delta (10K) to the value of minimum leaving water temperature (5 °C)
 (2) The maximum flow rate corresponds to a pressure drop of 100 kPa in the heat exchanger plate

30RQM/30RQP 160-520 with low pressure hydraulic module

	Minimum flow rate (l/s) ⁽¹⁾	Maximum flow rate (l/s)	
		Single	Dual
160	2,9	12,2	10,3
180	3,1	12,2	12,2
210	3,8	14,3	14,0
230	4,1	14,3	14,0
240	4,2	20,3	18,0
270	4,8	20,3	18,0
310	5,5	20,3	18,5
330	5,8	25,0	25,0
380	6,7	25,0	25,0
430	7,8	25,0	25,0
470	8,4	28,6	26,6
520	9,2	28,6	28,6

- (1) Minimum flow rate for the conditions of permissible maximum water delta (10K) to the value of minimum leaving water temperature (5 °C)

30RQM/30RQP 160-520 with high pressure hydraulic module

	Minimum flow rate (l/s) ⁽¹⁾	Maximum flow rate (l/s)	
		Single	Dual
160	2,9	14,1	11,7
180	3,1	14,1	11,7
210	3,8	16,1	16,1
230	4,1	16,1	16,1
240	4,2	16,1	16,1
270	4,8	26,6	26,5
310	5,5	26,6	26,5
330	5,8	26,6	26,5
380	6,7	26,6	29,2
430	7,8	26,7	29,2
470	8,4	26,7	35,0
520	9,2	35,0	35,0

- (1) Minimum flow rate for the conditions of permissible maximum water delta (10K) to the value of minimum leaving water temperature (5 °C).

Unit operating limits

Units 30RQM/RQP 160-520 Cooling Mode

Water heat exchanger	Minimum	Maximum	
Water inlet temperature at start-up	°C	8 ⁽¹⁾	40
Water outlet temperature during operation	°C	5 ⁽²⁾	20 ⁽³⁾
Water outlet temperature during operation Low-temperature brine option	°C	-8 ⁽⁸⁾	20 ⁽³⁾
Air heat exchanger	Minimum	Maximum	
Ambient operating temperature - 30RQM	°C	0 ⁽⁴⁾⁽⁶⁾	48 ⁽⁷⁾
Ambient operating temperature - 30RQM option 28 or 30RQP	°C	-20 ⁽⁴⁾⁽⁶⁾	48 ⁽⁷⁾
Available static pressure	Minimum	Maximum	
Standard unit (outdoor installation)	Pa	0	0

Units 30RQM/RQP 160-520 Heating Mode

Water heat exchanger	Minimum	Maximum	
Water inlet temperature at start-up	°C	8 ⁽¹⁾	50
Water outlet temperature during operation	°C	20	55
Air heat exchanger	Minimum	Maximum	
Outdoor ambient operating temperature	°C	-10 ⁽⁵⁾⁽⁶⁾	35
Available static pressure	Minimum	Maximum	
Standard unit (for outdoor installation)	Pa	0	0

- (1) For an application requiring operation at less than 8°C, contact Carrier to select a unit from the Carrier electronic catalogue.
 (2) Use of antifreeze protection is required if the leaving water temperature is below 5 °C.
 (3) For applications requiring operation with a water outlet temperature above 20°C, contact Carrier to select a unit from the Carrier electronic catalogue.
 (4) For operation from 0°C down to -20°C (cooling mode), heat pump must be a 30RQM unit equipped with option 28 "Winter operation" or must be a 30RQP unit.
 (5) For operation from 0°C down to -10°C (heating mode), heat pump shall be equipped with option 252 "Coil defrost resistance heaters".
 (6) For any operation below 0°C (cooling mode and heating mode), the heat pump must be equipped with option 41 "Water exchanger frost protection" (unit without hydraulic module) or with option 42A "Water exchanger and hydraulic module frost protection" (unit with hydraulic module) or the water circuit must be protected against frost using an anti-freeze solution.
 (7) The maximum ambient temperature allowed for machines equipped with option 231 is +40°C.
 (8) Operation with low temperature brine for 30RQP 180/230/270/310 only

Maximum ambient temperature: in case of 30RQM/30RQP units storage and transport, minimum and maximum ambient temperatures to respect are -20°C and +52°C. These temperature limits shall be considered in case of container shipment.

OPERATING LIMITS

Operating range for 30RQM/RQP 160-520 cooling mode

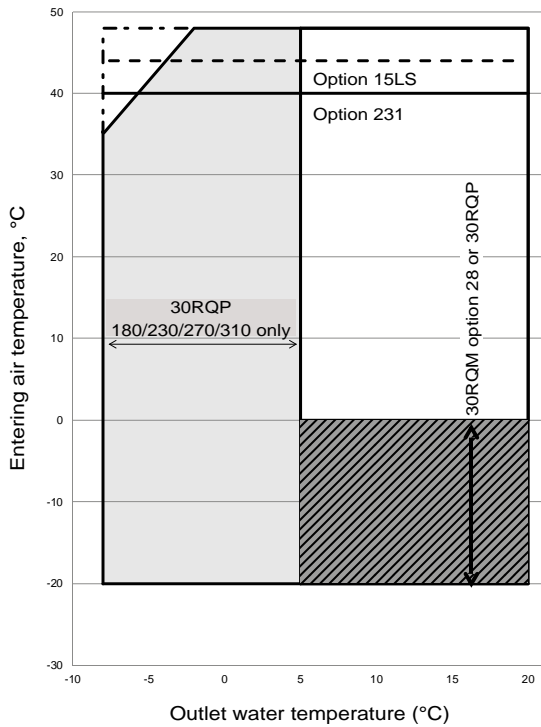

Operating range for 30RQM/RQP 160-520 heating mode

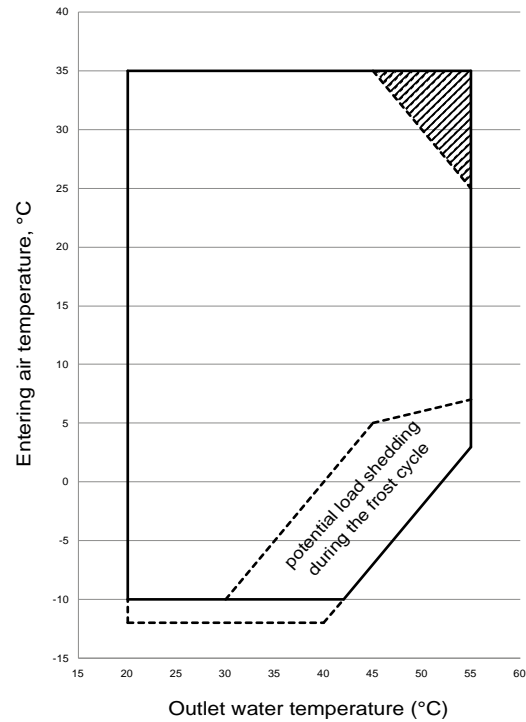

Notes

- 1 Evaporator $\Delta T = 3K$
- 2 The unit must be equipped with the water heat exchanger frost protection option (for units without hydraulic module option) or the water heat exchanger and hydraulic module frost protection option (for units with hydraulic module option) or the water loop must be protected against frost using an anti-freeze solution for outdoor air temperatures below 0°C
- 3 Operating ranges are guidelines only. The operating range must be checked with the selection software

Key

- Operating range at full load, 30RQM unit or 30RQP unit
- Extended operating range in cooling mode: 30RQM unit, option 28 "Winter operation" down to outside temperatures of -20°C or 30RQP unit. The water heat exchanger must be protected against frost (see note 2).
- Operating range at part load for 30RQM/30RQP 310 unit. Other sizes operate at full load.
- Potential load shedding during the frost cycle depending on the humidity conditions. Refer to the manufacturer's electronic catalogue.
- Low temperature brine solution option
- Partial load for low temperature brine solution option

AVAILABLE STATIC SYSTEM PRESSURE

Data applicable for:

- Fresh water 20 °C
- Refer to the paragraph "Heat exchanger water flow rate" for maximum water flow values.
- In case of use of the glycol, the maximum water flow rate is reduced.

Units 30RQM/30RQP high-pressure pumps (fixed speed or variable speed at 50Hz)

Single pumps

Sizes 160-240

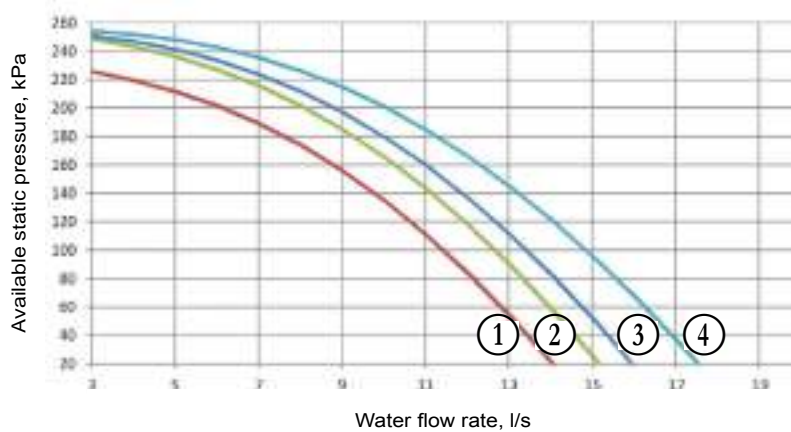

- ① 30RQM/30RQP 160-180
- ② 30RQM/30RQP 210
- ③ 30RQM/30RQP 230
- ④ 30RQM/30RQP 240

Sizes 270-520

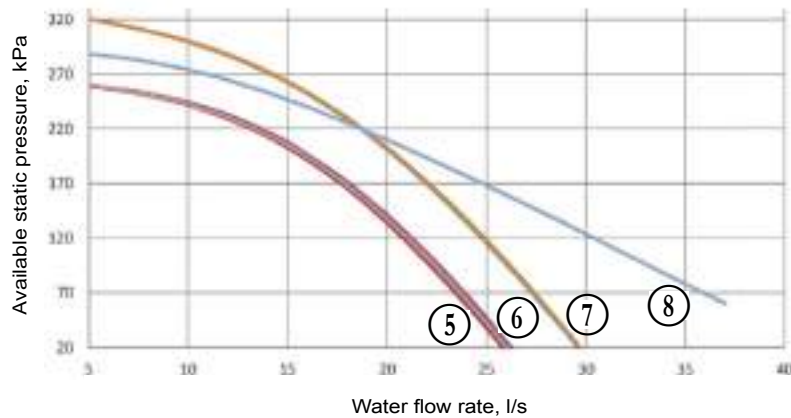

- ⑤ 30RQM/30RQP 270-310
- ⑥ 30RQM/30RQP 330-380
- ⑦ 30RQM/30RQP 430-470
- ⑧ 30RQM/30RQP 520

AVAILABLE STATIC SYSTEM PRESSURE

Dual pumps

Sizes 160-240

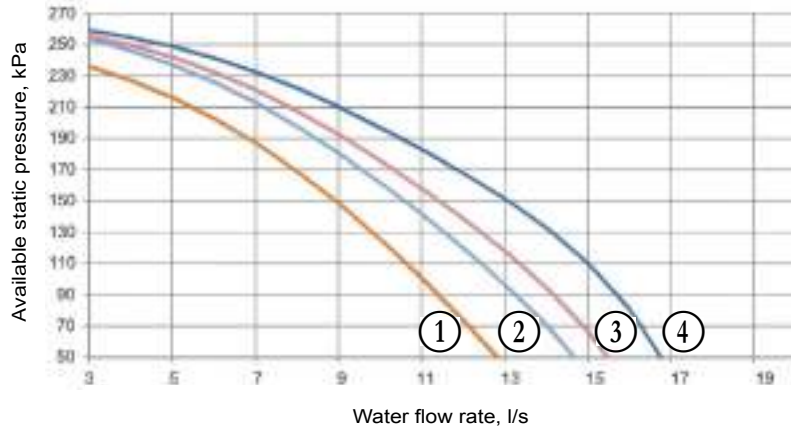

- ① 30RQM/30RQP 160-180
- ② 30RQM/30RQP 210
- ③ 30RQM/30RQP 230
- ④ 30RQM/30RQP 240

Sizes 270-520

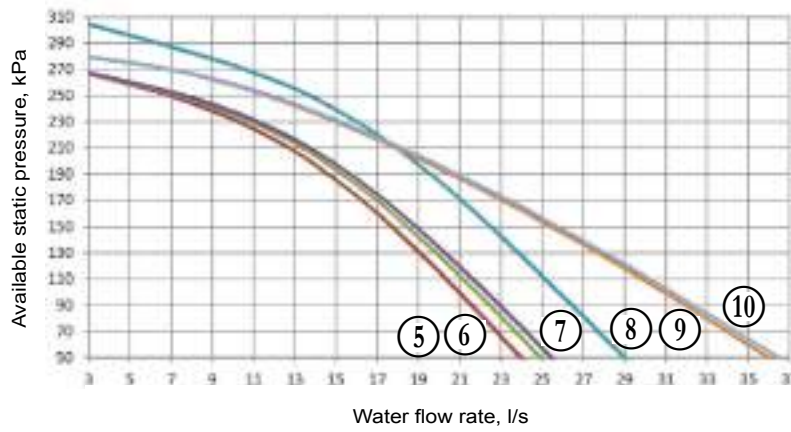

- ⑤ 30RQM/30RQP 270
- ⑥ 30RQM/30RQP 310
- ⑦ 30RQM/30RQP 330
- ⑧ 30RQM/30RQP 380-430
- ⑨ 30RQM/30RQP 470
- ⑩ 30RQM/30RQP 520

AVAILABLE STATIC SYSTEM PRESSURE

Data applicable for:

- Fresh water 20 °C
- Refer to the paragraph "Heat exchanger water flow rate" for maximum water flow values.
- In case of use of the glycol, the maximum water flow rate is reduced.

Units 30RQM/30RQP low-pressure pumps (fixed speed)

Single pumps

Sizes 160-270

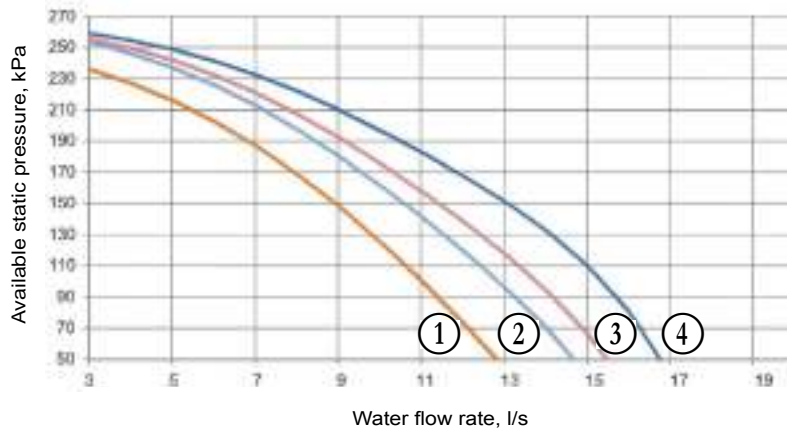

- ① 30RQM/30RQP 160-180
- ② 30RQM/30RQP 210
- ③ 30RQM/30RQP 230
- ④ 30RQM/30RQP 240-270

Sizes 310-520

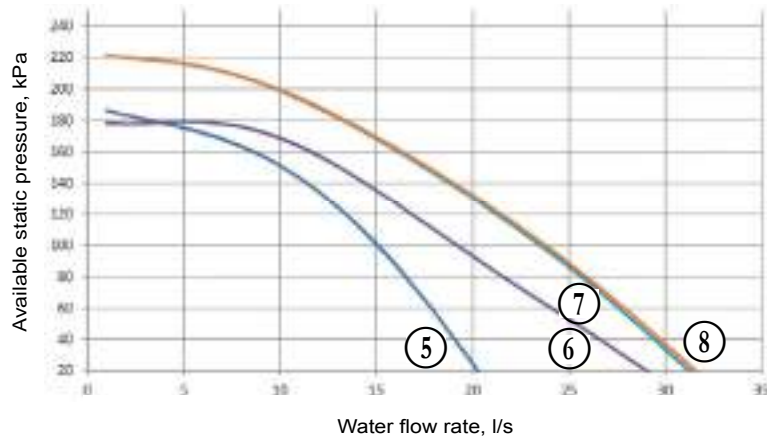

- ⑤ 30RQM/30RQP 310
- ⑥ 30RQM/30RQP 330-380-430
- ⑦ 30RQM/30RQP 470
- ⑧ 30RQM/30RQP 520

AVAILABLE STATIC SYSTEM PRESSURE

Dual pumps

Sizes 160-230

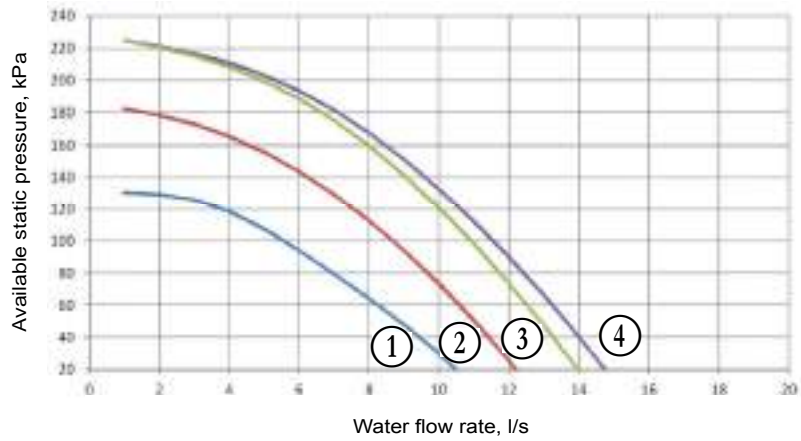

- ① 30RQM/30RQP 160
- ② 30RQM/30RQP 180
- ③ 30RQM/30RQP 210
- ④ 30RQM/30RQP 230

Sizes 240-520

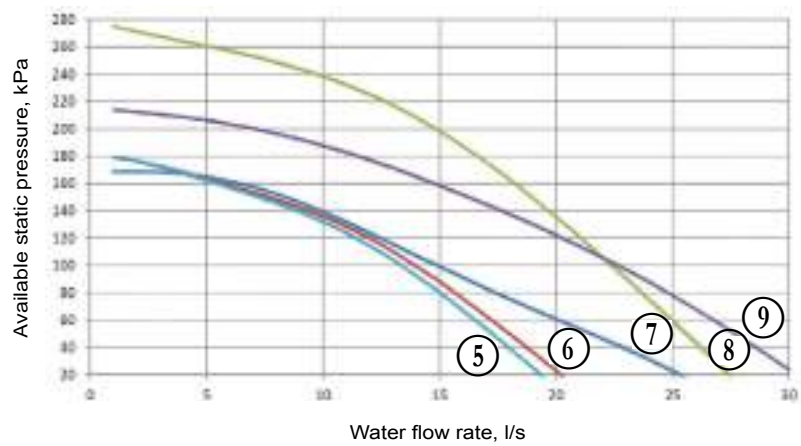

- ⑤ 30RQM/30RQP 240-270
- ⑥ 30RQM/30RQP 310
- ⑦ 30RQM/30RQP 330-380-430
- ⑧ 30RQM/30RQP 470
- ⑨ 30RQM/30RQP 520

DIMENSIONS/CLEARANCES

30RQM/30RQP 160-230 (with and without hydraulic module)

Unit without hydraulic module

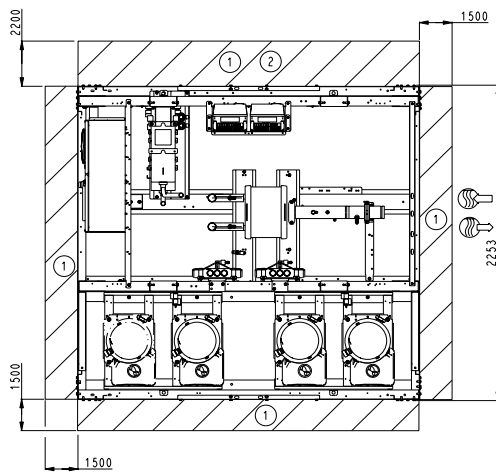
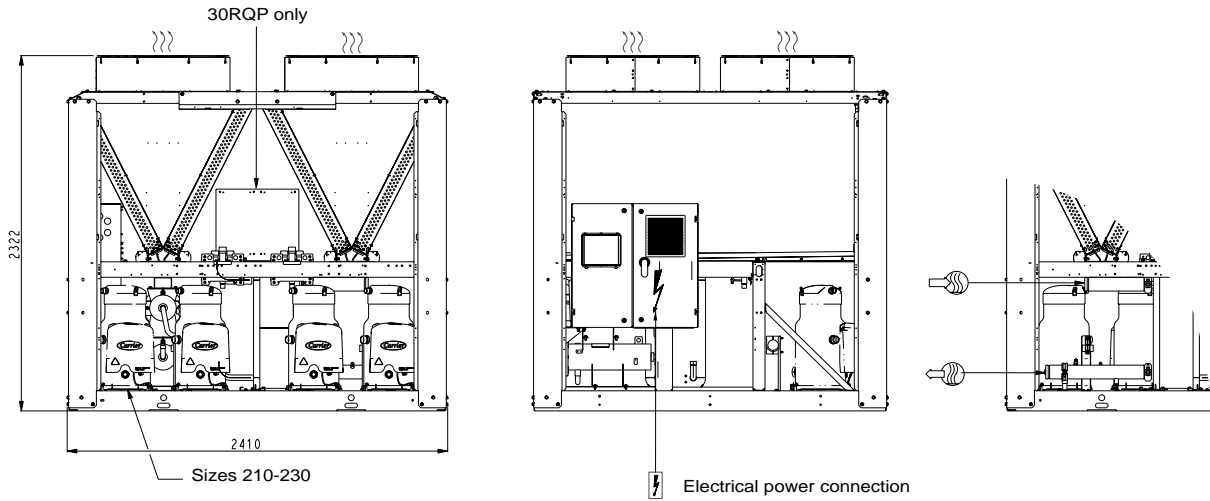

Key:

All dimensions are in mm.

- ① Clearances required for maintenance and air flow
- ② Clearances recommended for removal of the coils

Water inlet

Water outlet

Air outlet, do not obstruct

Control box

Note: Drawings are not contractually binding. Before designing an installation, consult the certified dimensional drawings, available on request.

For the positioning of the fixing points, weight distribution points and center of gravity coordinates please refer to the dimensional drawings.

Unit with hydraulic module

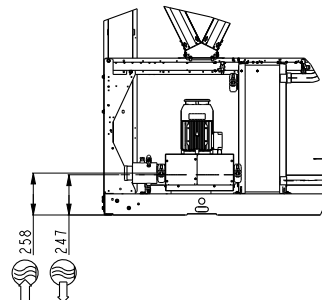
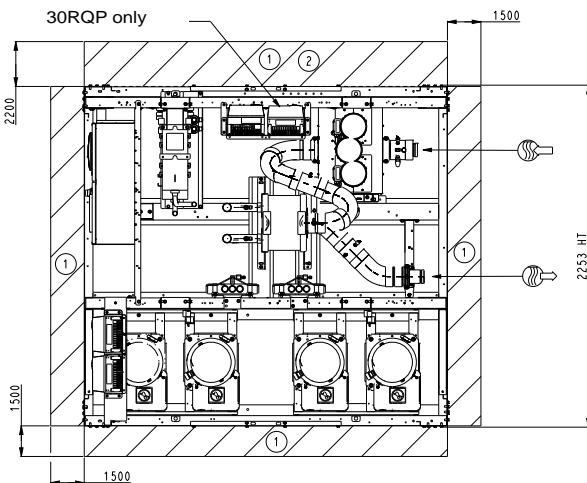

DIMENSIONS/CLEARANCES

30RQM/30RQP 240-330 (with and without hydraulic module)

Unit without hydraulic module

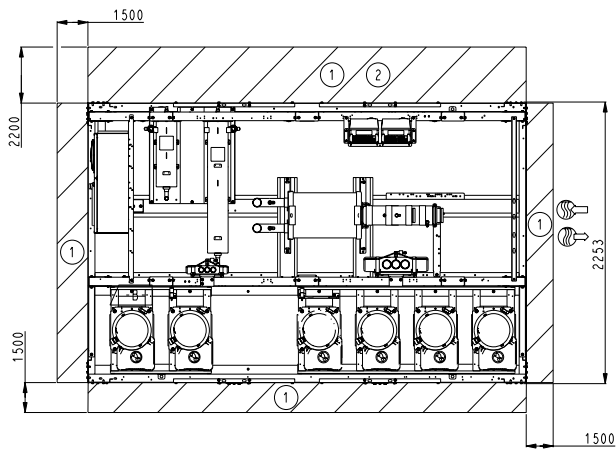
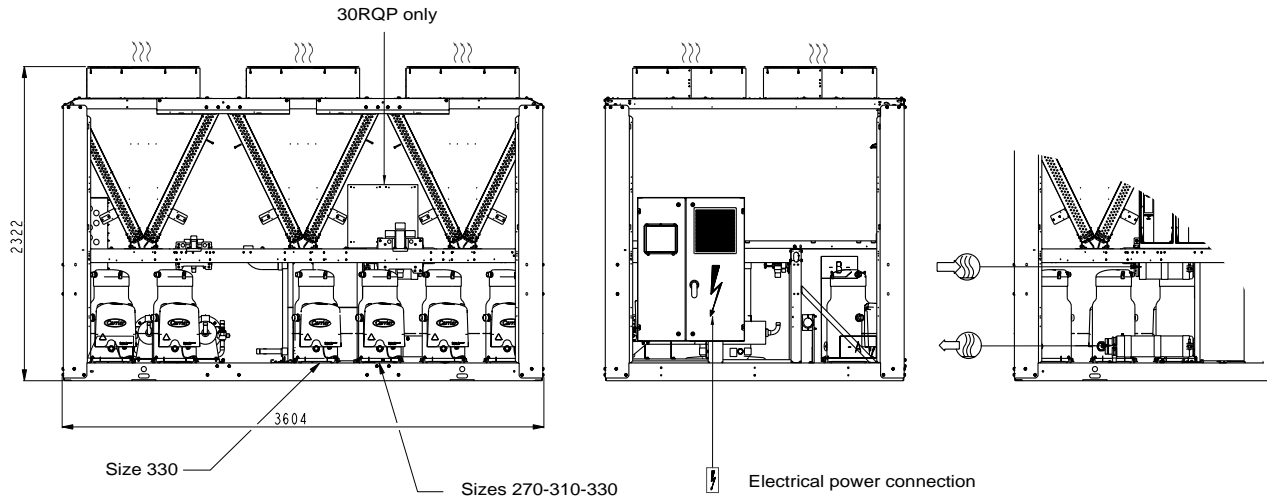

- Key:**
 All dimensions are in mm.
 ① Clearances required for maintenance and air flow
 ② Clearances recommended for removal of the coils
 Water inlet
 Water outlet
 Air outlet, do not obstruct
 Control box

Note: Drawings are not contractually binding. Before designing an installation, consult the certified dimensional drawings, available on request.

For the positioning of the fixing points, weight distribution points and center of gravity coordinates please refer to the dimensional drawings.

Unit with hydraulic module

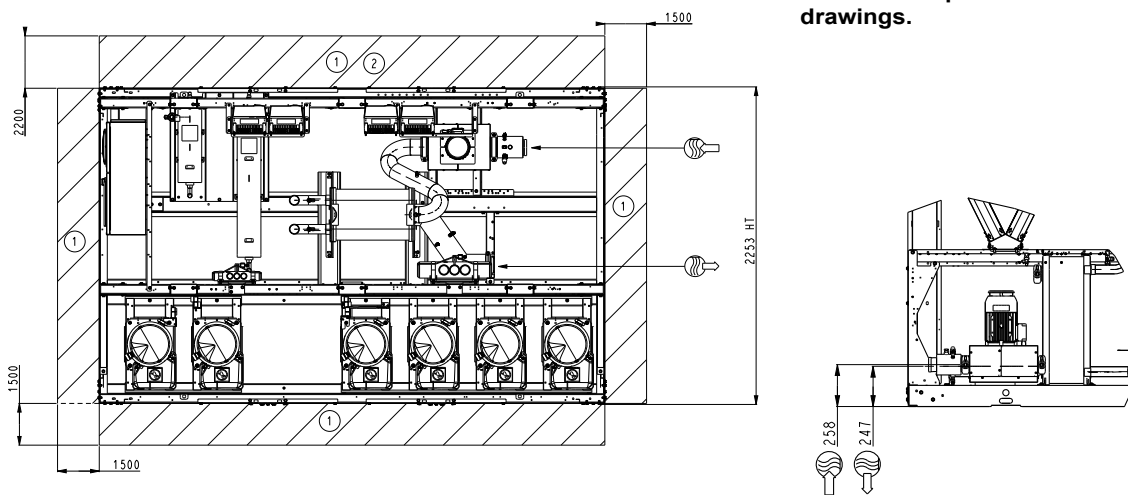

DIMENSIONS/CLEARANCES

30RQM/30RQP 380-520 (with and without hydraulic module)

Unit without hydraulic module

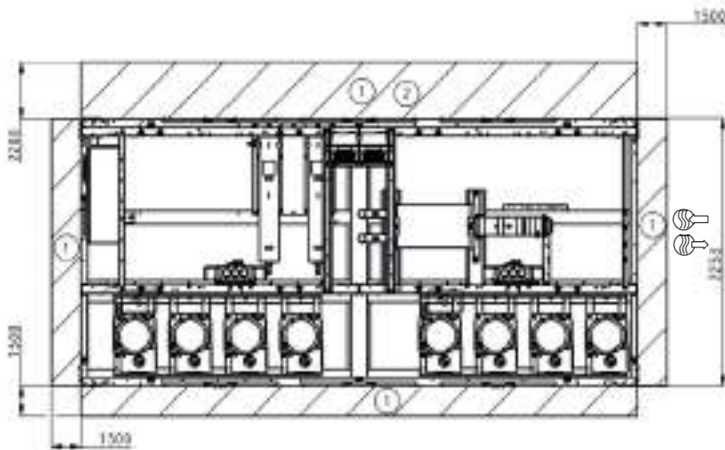
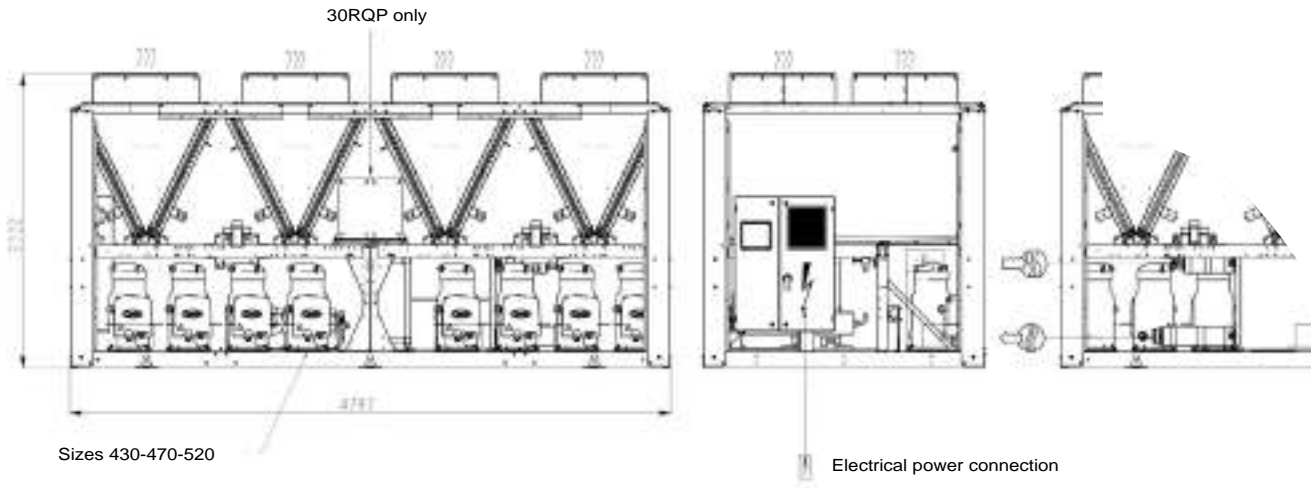

Key:

All dimensions are in mm.

- ① Clearances required for maintenance and air flow
- ② Clearances recommended for removal of the coils

Water inlet

Water outlet

Air outlet, do not obstruct

Control box

Note: Drawings are not contractually binding. Before designing an installation, consult the certified dimensional drawings, available on request.

For the positioning of the fixing points, weight distribution points and center of gravity coordinates please refer to the dimensional drawings.

Unit with hydraulic module

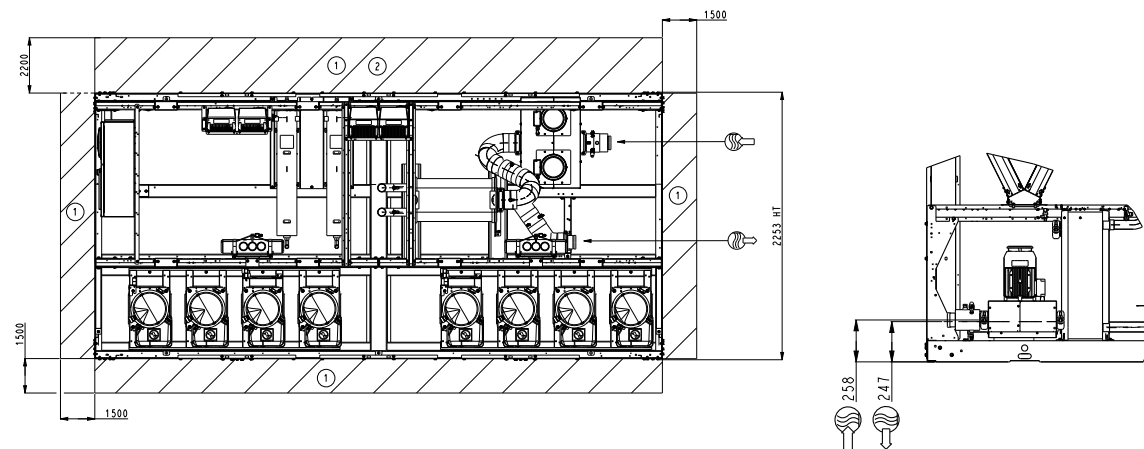



Order No.: 10019, 05.2019. Supersedes order No.: 10019, 11.2018.
Manufacturer reserves the right to change any product specifications without notice.
The illustrations in this document are for illustrative purposes only and not part of any offer for sale or contract. The manufacturer reserves the right to change the design at any time without notice.

Manufactured by: Carrier SCS, Montluel, France.
Printed in the European Union.



Quality and Environment
Management Systems
Approval