



Section 29. Real-Time Clock and Calendar (RTCC)

HIGHLIGHTS

This section of the manual contains the following topics:

29.1	Introduction	29-2
29.2	Status and Control Registers	29-3
29.3	Modes of Operation	29-13
29.4	Alarm	29-21
29.5	Interrupts.....	29-25
29.6	Operation in Power-Saving modes.....	29-27
29.7	Effects of Various Resets.....	29-28
29.8	Related Application Notes	29-29
29.9	Revision History.....	29-30

Note: This family reference manual section is meant to serve as a complement to device data sheets. Depending on the device variant, this manual section may not apply to all PIC32 devices.

Please consult the note at the beginning of the “**Real-Time Clock and Calendar (RTCC)**” chapter in the current device data sheet to check whether this document supports the device you are using.

Device data sheets and family reference manual sections are available for download from the Microchip Worldwide Web site at: <http://www.microchip.com>

29.1 INTRODUCTION

This section discusses the Real-Time Clock and Calendar (RTCC) hardware module, available on PIC32 devices, and its operation. Listed below are some of the key features of this module:

- Time in hours, minutes and seconds
- 24-hour format (military time)
- Visibility of one-half second period
- Provides calendar for weekday, date, month and year
- Alarm configurable for half a second, one second, 10 seconds, one minute, 10 minutes, one hour, one day, one week, one month, one year
- Alarm repeat with decrementing counter
- Alarm with indefinite repeat
- Year range from 2000 to 2099
- Leap year correction
- Binary Coded Decimal (BCD) format for smaller firmware overhead
- Optimized for long term battery operation
- Fractional second synchronization
- User calibration of the clock crystal frequency with auto-adjust
- Calibration range of ± 0.66 seconds error per month
- Calibrates up to 260 ppm of crystal error
- Uses external 32.768 kHz clock crystal or internal 32 kHz internal oscillator
- Alarm pulse, seconds clock, or RTCC clock output on the RTCC pin

This module provides real-time clock and calendar functions. The RTCC is intended for applications where accurate time must be maintained for extended periods with minimum to no intervention from the CPU. The module is optimized for low-power usage in order to provide extended battery life while keeping track of time.

The RTCC module is a 100-year clock and calendar with automatic leap year detection. The range of the clock is from 00:00:00 (midnight) on January 1, 2000 to 23:59:59 on December 31, 2099. The hours are available in 24-hour (military time) format. The clock provides a granularity of one second with half-second visibility to the user.

[Figure 29-1](#) illustrates the block diagram of the RTCC module.

Section 29. Real-Time Clock and Calendar (RTCC)

Figure 29-1: RTCC Block Diagram

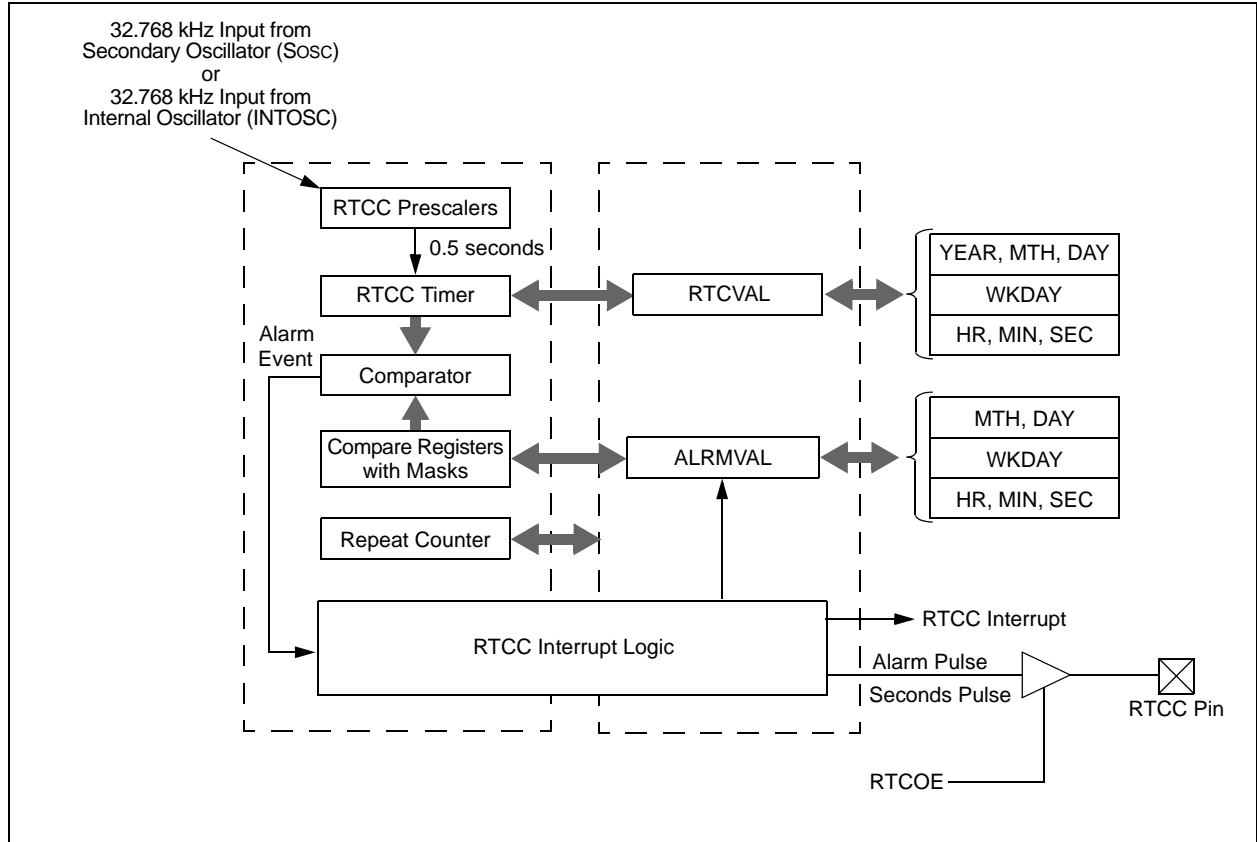

29.2 STATUS AND CONTROL REGISTERS

The RTCC module includes the following Special Function Registers (SFRs):

- **RTCCON: RTC Control Register**
The RTCCON register controls the operation of the RTCC module.
- **RTCALRM: RTC ALARM Control Register⁽¹⁾**
The RTCALRM register controls the alarm functions of the RTCC module.
- **RTCTIME: RTC Time Value Register**
The RTCC Time register sets the Hour, Minutes and Seconds fields.
- **RTCDATE: RTC Date Value Register**
The RTCC Date register sets the Year, Month, Day and Weekday fields.
- **ALRMTIME: Alarm Time Value Register**
The RTCC Alarm Time register sets the Alarm Hour, Minutes and Seconds fields.
- **ALRMDATE: Alarm Date Value Register**
The RTCC Alarm Date register sets the Alarm Month, Day and Weekday fields.

PIC32 Family Reference Manual

The following table summarizes all related RTCC registers. Corresponding registers appear after the summary, followed by a detailed description of each register.

Table 29-1: RTCC SFR Summary

Name		Bit 31/23/15/7	Bit 30/22/14/6	Bit 29/21/13/5	Bit 28/20/12/4	Bit 27/19/11/3	Bit 26/18/10/2	Bit 25/17/9/1	Bit 24/16/8/0
RTCCON ⁽¹⁾	31:24	—	—	—	—	—	—	CAL<9:8>	
	23:16	CAL<7:0>							
	15:8	ON	—	SIDL	—	—	—	—	—
	7:0	RTSECSEL ⁽²⁾ RTCOUTSEL<0> ⁽²⁾	RTCCLKON	—	—	RTCWREN	RTCSYNC	HALFSEC	RTCOE
RTCALRM ⁽¹⁾	31:24	—	—	—	—	—	—	—	—
	23:16	—	—	—	—	—	—	—	—
	15:8	ALRMEN	CHIME	PIV	ALRMSYNC	AMASK<3:0>			
	7:0	ARPT<7:0>							
RTCTIME ⁽¹⁾	31:24	—	—	HR10<1:0>		HR01<3:0>			
	23:16	—	MIN10<2:0>			MIN01<3:0>			
	15:8	—	SEC10<2:0>			SEC01<3:0>			
	7:0	—	—	—	—	—	—	—	—
RTCDATE ⁽¹⁾	31:24	YEAR10<3:0>				YEAR01<3:0>			
	23:16	—	—	—	MONTH10	MONTH01<3:0>			
	15:8	—	—	DAY10<1:0>		DAY01<3:0>			
	7:0	—	—	—	—	—	WDAY01<2:0>		
ALRMTIME ⁽¹⁾	31:24	—	—	HR10<1:0>		HR01<3:0>			
	23:16	—	MIN10<2:0>			MIN01<3:0>			
	15:8	—	SEC10<2:0>			SEC01<3:0>			
	7:0	—	—	—	—	—	—	—	—
ALRMDATE ⁽¹⁾	31:24	—	—	—	—	—	—	—	—
	23:16	—	—	—	MONTH10	MONTH01<3:0>			
	15:8	—	—	DAY10<1:0>		DAY01<3:0>			
	7:0	—	—	—	—	—	WDAY01<2:0>		

Legend: — = unimplemented, read as '0'. Address offset values are shown in hexadecimal.

Note 1: This register has an associated Clear, Set, and Invert register at an offset of 0x4, 0x8, and 0xC bytes, respectively. These registers have the same name with CLR, SET, or INV appended to the end of the register name (e.g., RTCCONCLR). Writing a '1' to any bit position in these registers will clear valid bits in the associated register. Reads from these registers should be ignored.

Note 2: These bits are not available on all devices. If the bit is not available, the field is unimplemented and is read as '0'. Refer to the "RTCC" chapter in the specific device data sheet for availability.

Section 29. Real-Time Clock and Calendar (RTCC)

Register 29-1: RTCCON: RTC Control Register

Bit Range	Bit 31/23/15/7	Bit 30/22/14/6	Bit 29/21/13/5	Bit 28/20/12/4	Bit 27/19/11/3	Bit 26/18/10/2	Bit 25/17/9/1	Bit 24/16/8/0
31:24	U-0	U-0	U-0	U-0	U-0	U-0	R/W-0	R/W-0
	—	—	—	—	—	—	CAL<9:8>	
23:16	R/W-0	R/W-0	R/W-0	R/W-0	R/W-0	R/W-0	R/W-0	R/W-0
	CAL<7:0>							
15:8	R/W-0	U-0	R/W-0	U-0	U-0	R/W-0	R/W-0	R/W-0
	ON ^(1,2)	—	SIDL	—	—	—	—	—
						RTC CLKSEL<1:0> ⁽⁷⁾		RTC OUTSEL<1> ⁽⁷⁾
7:0	R/W-0	R-0	U-0	U-0	R/W-0	R-0	R-0	R/W-0
	RTSECSEL ^(3,7)	RTCCCLKON	—	—	RTC WREN ⁽⁴⁾	RTCSYNC	HALF SEC ⁽⁵⁾	RTCOE ⁽⁶⁾
	RTC OUTSEL<0> ⁽⁷⁾							

Legend:			
R = Readable bit	W = Writable bit	U = Unimplemented bit, read as '0'	
-n = Value at POR	'1' = Bit is set	'0' = Bit is cleared	x = Bit is unknown

bit 31-26 **Unimplemented:** Read as '0'

bit 25-16 **CAL<9:0>:** RTC Drift Calibration bits, which contain a signed 10-bit integer value

0111111111 = Maximum positive adjustment, adds 511 RTC clock pulses every one minute

-
-
-

0000000001 = Minimum positive adjustment, adds 1 RTC clock pulse every one minute

0000000000 = No adjustment

1111111111 = Minimum negative adjustment, subtracts 1 RTC clock pulse every one minute

-
-
-

1000000000 = Minimum negative adjustment, subtracts 512 clock pulses every one minute

bit 15 **ON:** RTCC On bit^(1,2)

1 = RTCC module is enabled

0 = RTCC module is disabled

bit 14 **Unimplemented:** Read as '0'

Note 1: The ON bit is only writable when RTCWREN = 1.

2: When using the 1:1 PBCLK divisor, the user's software should not read/write the peripheral's SFRs in the SYSCLK cycle immediately following the instruction that clears the module's ON bit.

3: Requires RTCOE == 1 (RTCCON<0>) for the output to be active.

4: The RTCWREN bit can be set only when the write sequence is enabled.

5: This bit is read-only. It is cleared to '0' on a write to the seconds bit fields (RTCTIME<14:8>).

6: This bit is ANDed with the ON bit (RTCCON<15>) to produce the effective RTCC output enable.

7: This bit is not available on all devices. If the bit is not available, the field is Unimplemented and is read as '0'. Refer to the "RTCC" chapter in the specific device data sheet for availability.

Note: This register is reset only on a Power-on Reset (POR).

PIC32 Family Reference Manual

Register 29-1: RTCCON: RTC Control Register (Continued)

- bit 13 **SIDL**: Stop in Idle Mode bit
1 = Disables the PBCLK to the RTCC when CPU enters in Idle mode
0 = Continue normal operation in Idle mode
- bit 12-11 **Unimplemented**: Read as '0'⁽⁷⁾
- bit 10-9 **RTCCCLKSEL<1:0>**: RTCC Clock Select bits⁽⁷⁾
11 = Reserved; do not use
10 = Reserved; do not use
01 = RTCC uses the external 32.768 kHz Secondary Oscillator (SOSC)
00 = RTCC uses the internal 32 kHz oscillator (INTOSC)
When a new value is written to these bits, the Seconds Value register should also be written to properly reset the clock prescalers in the RTCC.
- bit 8-7 **RTCCOUTSEL<1:0>**: RTCC Output Data Select bits⁽⁷⁾
11 = Reserved, do not use
10 = RTCC Clock is presented on the RTCC pin
01 = Seconds Clock is presented on the RTCC pin
00 = Alarm Pulse is presented on the RTCC pin when the alarm interrupt is triggered
- bit 7 **RTSECSEL**: RTCC Seconds Clock Output Select bit^(3,7)
1 = RTCC Seconds Clock is selected for the RTCC pin
0 = RTCC Alarm Pulse is selected for the RTCC pin
- bit 6 **RTCCCLKON**: RTCC Clock Enable Status bit
1 = RTCC Clock is actively running
0 = RTCC Clock is not running
- bit 5-4 **Unimplemented**: Read as '0'
- bit 3 **RTCWREN**: RTC Value Registers Write Enable bit⁽⁴⁾
1 = RTC Value registers can be written to by the user
0 = RTC Value registers are locked out from being written to by the user
- bit 2 **RTCSYNC**: RTCC Value Registers Read Synchronization bit
1 = RTC Value registers can change while reading, due to a rollover ripple that results in an invalid data read
If the register is read twice and results in the same data, the data can be assumed to be valid
0 = RTC Value registers can be read without concern about a rollover ripple
- bit 1 **HALFSEC**: Half-Second Status bit⁽⁵⁾
1 = Second half period of a second
0 = First half period of a second
- bit 0 **RTCOE**: RTCC Output Enable bit⁽⁶⁾
1 = RTCC clock output enabled – clock presented onto an I/O
0 = RTCC clock output disabled

- Note 1:** The ON bit is only writable when RTCWREN = 1.
- 2:** When using the 1:1 PBCLK divisor, the user's software should not read/write the peripheral's SFRs in the SYSCLK cycle immediately following the instruction that clears the module's ON bit.
- 3:** Requires RTCOE == 1 (RTCCON<0>) for the output to be active.
- 4:** The RTCWREN bit can be set only when the write sequence is enabled.
- 5:** This bit is read-only. It is cleared to '0' on a write to the seconds bit fields (RTCTIME<14:8>).
- 6:** This bit is ANDed with the ON bit (RTCCON<15>) to produce the effective RTCC output enable.
- 7:** This bit is not available on all devices. If the bit is not available, the field is Unimplemented and is read as '0'. Refer to the "RTCC" chapter in the specific device data sheet for availability.

Note: This register is reset only on a Power-on Reset (POR).

Section 29. Real-Time Clock and Calendar (RTCC)

Register 29-2: RTCALRM: RTC ALARM Control Register⁽¹⁾

Bit Range	Bit 31/23/15/7	Bit 30/22/14/6	Bit 29/21/13/5	Bit 28/20/12/4	Bit 27/19/11/3	Bit 26/18/10/2	Bit 25/17/9/1	Bit 24/16/8/0
31:24	U-0	U-0	U-0	U-0	U-0	U-0	U-0	U-0
	—	—	—	—	—	—	—	—
23:16	U-0	U-0	U-0	U-0	U-0	U-0	U-0	U-0
	—	—	—	—	—	—	—	—
15:8	R/W-0	R/W-0	R/W-0	R-0	R/W-0	R/W-0	R/W-0	R/W-0
	ALRMEN ^(1,2)	CHIME ⁽²⁾	PIV ⁽²⁾	ALRMSYNC ⁽³⁾	AMASK<3:0> ⁽²⁾			
7:0	R/W-0	R/W-0	R/W-0	R/W-0	R/W-0	R/W-0	R/W-0	R/W-0
	ARPT<7:0> ⁽²⁾							

Legend:

R = Readable bit	W = Writable bit	U = Unimplemented bit, read as '0'
-n = Value at POR	'1' = Bit is set	'0' = Bit is cleared x = Bit is unknown

bit 31-16 **Unimplemented:** Read as '0'

bit 15 **ALRMEN:** Alarm Enable bit^(2,3)

- 1 = Alarm is enabled
- 0 = Alarm is disabled

bit 14 **CHIME:** Chime Enable bit⁽³⁾

- 1 = Chime is enabled – ARPT<7:0> is allowed to rollover from 0x00 to 0xFF
- 0 = Chime is disabled – ARPT<7:0> stops once it reaches 0x00

bit 13 **PIV:** Alarm Pulse Initial Value bit⁽³⁾

- When ALRMEN = 0, PIV is writable and determines the initial value of the Alarm Pulse.
- When ALRMEN = 1, PIV is read-only and returns the state of the Alarm Pulse.

bit 12 **ALRMSYNC:** Alarm Sync bit⁽⁴⁾

- 1 = ARPT<7:0> and ALRMEN may change as a result of a half second rollover during a read.
The ARPT must be read repeatedly until the same value is read twice. This must be done since multiple bits may be changing, which are then synchronized to the PB clock domain
- 0 = ARPT<7:0> and ALRMEN can be read without concerns of rollover because the prescaler is > 32 RTC clocks away from a half-second rollover

bit 11-8 **AMASK<3:0>:** Alarm Mask Configuration bits⁽³⁾

- 0000 = Every half-second
- 0001 = Every second
- 0010 = Every 10 seconds
- 0011 = Every minute
- 0100 = Every 10 minutes
- 0101 = Every hour
- 0110 = Once a day
- 0111 = Once a week
- 1000 = Once a month
- 1001 = Once a year (except when configured for February 29, once every four years)
- 1010 = Reserved; do not use
- 1011 = Reserved; do not use
- 11xx = Reserved; do not use

- Note 1:** Hardware clears the ALRMEN bit anytime the alarm event occurs, when ARPT<7:0> = 00 and CHIME = 0.
- 2:** This field should not be written when the RTCC ON bit = '1' (RTCCON<15>) and ALRMSYNC = 1.
- 3:** This assumes a CPU read will execute in less than 32 PBCLKs.

Note: This register is reset only on a Power-on Reset (POR).

PIC32 Family Reference Manual

Register 29-2: RTCALRM: RTC ALARM Control Register⁽¹⁾ (Continued)

bit 7-0 **ARPT<7:0>**: Alarm Repeat Counter Value bits⁽³⁾

11111111 = Alarm will trigger 256 times

-
-
-

00000000 = Alarm will trigger one time

The counter decrements on any alarm event. The counter only rolls over from 0x00 to 0xFF if CHIME = 1.

- Note 1:** Hardware clears the ALRMEN bit anytime the alarm event occurs, when ARPT<7:0> = 00 and CHIME = 0.
- 2:** This field should not be written when the RTCC ON bit = '1' (RTCCON<15>) and ALRMSYNC = 1.
- 3:** This assumes a CPU read will execute in less than 32 PBCLKs.

Note: This register is reset only on a Power-on Reset (POR).

Section 29. Real-Time Clock and Calendar (RTCC)

Register 29-3: RTCTIME: RTC Time Value Register

Bit Range	Bit 31/23/15/7	Bit 30/22/14/6	Bit 29/21/13/5	Bit 28/20/12/4	Bit 27/19/11/3	Bit 26/18/10/2	Bit 25/17/9/1	Bit 24/16/8/0
31:24	U-0	U-0	R/W-x	R/W-x	R/W-x	R/W-x	R/W-x	R/W-x
	—	—	HR10<1:0>		HR01<3:0>			
23:16	U-0	R/W-x	R/W-x	R/W-x	R/W-x	R/W-x	R/W-x	R/W-x
	—	MIN10<2:0>			MIN01<3:0>			
15:8	U-0	R/W-x	R/W-x	R/W-x	R/W-x	R/W-x	R/W-x	R/W-x
	—	SEC10<2:0>			SEC01<3:0>			
7:0	U-0	U-0	U-0	U-0	U-0	U-0	U-0	U-0
	—	—	—	—	—	—	—	—

Legend:

R = Readable bit	W = Writable bit	U = Unimplemented bit, read as '0'
-n = Value at POR	'1' = Bit is set	'0' = Bit is cleared x = Bit is unknown

- bit 31-30 **Unimplemented:** Read as '0'
- bit 29-28 **HR10<1:0>:** Binary-Coded Decimal Value of Hours bits, 10 digits; contains a value from 0 to 2
- bit 27-24 **HR01<3:0>:** Binary-Coded Decimal Value of Hours bits, 1 digit; contains a value from 0 to 9
- bit 23 **Unimplemented:** Read as '0'
- bit 22-20 **MIN10<2:0>:** Binary-Coded Decimal Value of Minutes bits, 10 digits; contains a value from 0 to 5
- bit 19-16 **MIN01<3:0>:** Binary-Coded Decimal Value of Minutes bits, 1 digit; contains a value from 0 to 9
- bit 15 **Unimplemented:** Read as '0'
- bit 14-12 **SEC10<2:0>:** Binary-Coded Decimal Value of Seconds bits, 10 digits; contains a value from 0 to 5
- bit 11-8 **SEC01<3:0>:** Binary-Coded Decimal Value of Seconds bits, 1 digit; contains a value from 0 to 9
- bit 7-0 **Unimplemented:** Read as '0'

Note: This register is only writable when RTCWREN = 1 (RTCCON<3>).

PIC32 Family Reference Manual

Register 29-4: RTCDATE: RTC Date Value Register

Bit Range	Bit 31/23/15/7	Bit 30/22/14/6	Bit 29/21/13/5	Bit 28/20/12/4	Bit 27/19/11/3	Bit 26/18/10/2	Bit 25/17/9/1	Bit 24/16/8/0
31:24	R/W-x	R/W-x	R/W-x	R/W-x	R/W-x	R/W-x	R/W-x	R/W-x
	YEAR10<3:0>				YEAR01<3:0>			
23:16	U-0	U-0	U-0	R/W-x	R/W-x	R/W-x	R/W-x	R/W-x
	—	—	—	MONTH10	MONTH01<3:0>			
15:8	U-0	U-0	R/W-x	R/W-x	R/W-x	R/W-x	R/W-x	R/W-x
	—	—	DAY10<1:0>		DAY01<3:0>			
7:0	U-0	U-0	U-0	U-0	U-0	R/W-x	R/W-x	R/W-x
	—	—	—	—	—	WDAY01<2:0>		

Legend:

R = Readable bit

W = Writable bit

U = Unimplemented bit, read as '0'

-n = Value at POR

'1' = Bit is set

'0' = Bit is cleared

x = Bit is unknown

bit 31-28 **YEAR10<3:0>**: Binary-Coded Decimal Value of Years bits, 10 digits

bit 27-24 **YEAR01<3:0>**: Binary-Coded Decimal Value of Years bits, 1 digit

bit 23-21 **Unimplemented**: Read as '0'

bit 20 **MONTH10**: Binary-Coded Decimal Value of Months bits, 10 digits; contains a value from 0 to 1

bit 19-16 **MONTH01<3:0>**: Binary-Coded Decimal Value of Months bits, 1 digit; contains a value from 0 to 9

bit 15-14 **Unimplemented**: Read as '0'

bit 13-12 **DAY10<1:0>**: Binary-Coded Decimal Value of Days bits, 10 digits; contains a value from 0 to 3

bit 11-8 **DAY01<3:0>**: Binary-Coded Decimal Value of Days bits, 1 digit; contains a value from 0 to 9

bit 7-3 **Unimplemented**: Read as '0'

bit 2-0 **WDAY01<2:0>**: Binary-Coded Decimal Value of Weekdays bits, 1 digit; contains a value from 0 to 6

Note: This register is only writable when RTCWREN = 1 (RTCCON<3>).

Section 29. Real-Time Clock and Calendar (RTCC)

Register 29-5: ALRMTIME: Alarm Time Value Register

Bit Range	Bit 31/23/15/7	Bit 30/22/14/6	Bit 29/21/13/5	Bit 28/20/12/4	Bit 27/19/11/3	Bit 26/18/10/2	Bit 25/17/9/1	Bit 24/16/8/0
31:24	U-0	U-0	R/W-x	R/W-x	R/W-x	R/W-x	R/W-x	R/W-x
	—	—	HR10<1:0>		HR01<3:0>			
23:16	U-0	R/W-x	R/W-x	R/W-x	R/W-x	R/W-x	R/W-x	R/W-x
	—	MIN10<2:0>			MIN01<3:0>			
15:8	U-0	R/W-x	R/W-x	R/W-x	R/W-x	R/W-x	R/W-x	R/W-x
	—	SEC10<2:0>			SEC01<3:0>			
7:0	U-0	U-0	U-0	U-0	U-0	U-0	U-0	U-0
	—	—	—	—	—	—	—	—

Legend:

R = Readable bit	W = Writable bit	U = Unimplemented bit, read as '0'
-n = Value at POR	'1' = Bit is set	'0' = Bit is cleared x = Bit is unknown

- bit 31-30 **Unimplemented:** Read as '0'
- bit 29-28 **HR10<1:0>:** Binary Coded Decimal value of hours bits, 10 digits; contains a value from 0 to 2
- bit 27-24 **HR01<3:0>:** Binary Coded Decimal value of hours bits, 1 digit; contains a value from 0 to 9
- bit 23 **Unimplemented:** Read as '0'
- bit 22-20 **MIN10<2:0>:** Binary Coded Decimal value of minutes bits, 10 digits; contains a value from 0 to 5
- bit 19-16 **MIN01<3:0>:** Binary Coded Decimal value of minutes bits, 1 digit; contains a value from 0 to 9
- bit 15 **Unimplemented:** Read as '0'
- bit 14-12 **SEC10<2:0>:** Binary Coded Decimal value of seconds bits, 10 digits; contains a value from 0 to 5
- bit 11-8 **SEC01<3:0>:** Binary Coded Decimal value of seconds bits, 1 digit; contains a value from 0 to 9
- bit 7-0 **Unimplemented:** Read as '0'

PIC32 Family Reference Manual

Register 29-6: ALRMDATE: Alarm Date Value Register

Bit Range	Bit 31/23/15/7	Bit 30/22/14/6	Bit 29/21/13/5	Bit 28/20/12/4	Bit 27/19/11/3	Bit 26/18/10/2	Bit 25/17/9/1	Bit 24/16/8/0
31:24	U-0 —	U-0 —	U-0 —	U-0 —	U-0 —	U-0 —	U-0 —	U-0 —
23:16	U-0 —	U-0 —	U-0 —	R/W-x MONTH10	R/W-x MONTH01<3:0>			
15:8	U-0 —	U-0 —	R/W-x DAY10<1:0>	R/W-x	R/W-x DAY01<3:0>			
7:0	U-0 —	U-0 —	U-0 —	U-0 —	U-0 —	R/W-x	R/W-x	R/W-x WDAY01<2:0>

Legend:

R = Readable bit	W = Writable bit	U = Unimplemented bit, read as '0'
-n = Value at POR	'1' = Bit is set	'0' = Bit is cleared x = Bit is unknown

- bit 31-21 **Unimplemented:** Read as '0'
- bit 20 **MONTH10:** Binary Coded Decimal value of months bits, 10 digits; contains a value from 0 to 1
- bit 19-16 **MONTH01<3:0>:** Binary Coded Decimal value of months bits, 1 digit; contains a value from 0 to 9
- bit 15-14 **Unimplemented:** Read as '0'
- bit 13-12 **DAY10<1:0>:** Binary Coded Decimal value of days bits, 10 digits; contains a value from 0 to 3
- bit 11-8 **DAY01<3:0>:** Binary Coded Decimal value of days bits, 1 digit; contains a value from 0 to 9
- bit 7-3 **Unimplemented:** Read as '0'
- bit 2-0 **WDAY01<2:0>:** Binary Coded Decimal value of weekdays bits, 1 digit; contains a value from 0 to 6

Section 29. Real-Time Clock and Calendar (RTCC)

29.3 MODES OF OPERATION

The RTCC module offers the following operating modes:

- Real-Time Clock and Calendar (RTCC)
- Alarm

29.3.1 RTCC Mode of Operation

The RTCC is a 100-year clock and calendar with automatic leap year detection. The range of the clock is from 00:00:00 (midnight) on January 1, 2000, to 23:59:59 on December 31, 2099. The hours use the 24-hour time format (military time) with no hardware provisions for regular time format (AM/PM).

The RTCC provides a programming granularity of one second, but has visibility of the half-second field.

The register interface for the RTCC values (RTCTIME and RTCDATE) is implemented using the BCD format. This simplifies the firmware when using the module, as each of the digit values is contained within its own 4-bit value, as illustrated in [Figure 29-2](#).

Figure 29-2: Timer Digit Format

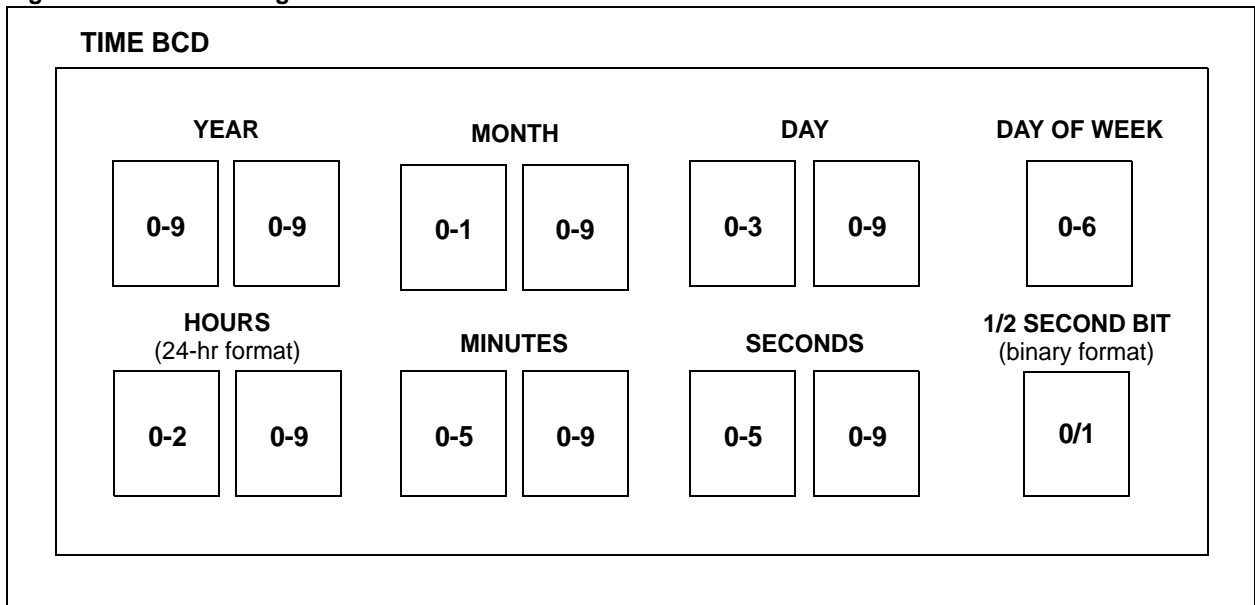

29.3.2 Alarm Mode of Operation

The RTCC module provides an alarm function configurable anywhere from a half-second to one year. However, only the half-second alarm has half-second resolution. After the alarm is enabled, the module can be configured to repeat the alarm at preconfigured intervals. The indefinite repetition of the alarm is provided through the Chime feature.

The module provides an interrupt at every alarm pulse event. In addition to the alarm interrupt, an alarm pulse output is provided that operates at half the frequency of the alarm (the alarm pulse toggles at every alarm match). This output is completely synchronous with the RTCC clock and can be used to provide a trigger clock to other devices. The initial value of this output pin is controlled by the PIV bit (RTCALRM<13>). For more information on the RTC Alarm control register, RTCALRM, see [Register 29-2](#).

The register interface for the Alarm values (ALRMTIME and ALRMDATE) is implemented using the BCD format. This simplifies the firmware when using the module, as each of the digit values is contained within its own 4-bit value, as illustrated in [Figure 29-3](#).

Figure 29-3: Timer and Alarm Digit Format

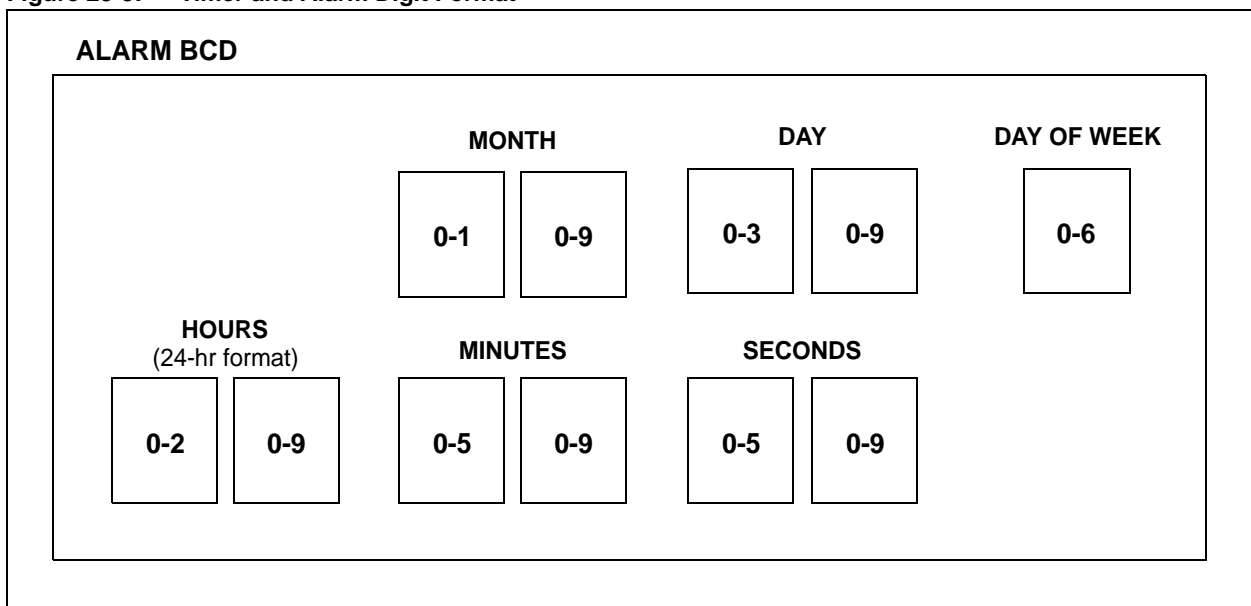

Section 29. Real-Time Clock and Calendar (RTCC)

29.3.3 Clock Source

Depending on the device, the RTCC module can be clocked from two different clock sources: an external real-time clock crystal (Sosc) that is oscillating at 32.768 kHz or through an internal 32 kHz clock source (INTOSC) from the clock module. The internal oscillator, INTOSC, does not use the external crystal, and does not operate during Deep Sleep modes. Calibration of the external crystal (Sosc) can be accomplished through the RTCC module, yielding an accuracy of ± 0.66 seconds per month. For more information, see [29.3.10 “Calibration”](#). When using the LPRC as the oscillator source for the RTCC, the accuracy can vary. Refer to the **“Oscillators”** chapter of the specific device data sheet for details on the accuracy of the LPRC.

Note: Not all devices have an external and internal oscillator. Refer to the **“Oscillators”** chapter in the specific device data sheet for availability.

For devices with an external and internal oscillator, to decide which source the RTCC module will use for clocking, the RTCCLKSEL<1:0> bits (RTCCON<10:9>) must be configured. Setting these bits to '00' selects the internal 32 kHz oscillator (INTOSC). Setting the bits to '01' selects the external Secondary Oscillator (Sosc). The settings '11' and '10' are reserved and should not be used.

When selecting the external oscillator, the SOSSEN bit (OSCCON<1>) must also be set (refer to the **“Oscillators”** chapter in the specific device data sheet for details). This is the only bit outside of the RTCC module with which the user must be concerned for enabling the RTCC. The status bit, SOSCRDY (OSCCON<22>), can be used to check that the Secondary Oscillator (Sosc) is running.

Figure 29-4: Clock Source and Counting

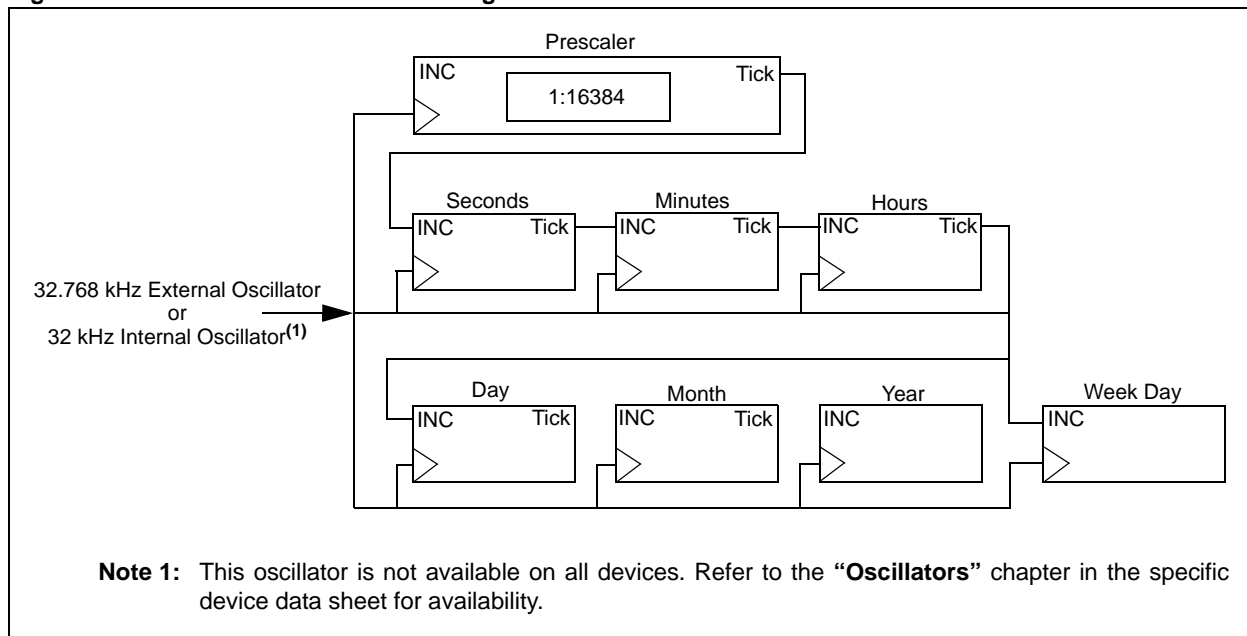

29.3.4 Digit Carry Rules

This section explains which timer values are affected when there is a rollover.

- Time of Day – from 23:59:59 to 00:00:00, with a carry to the Day field
- Day – the carry from the day field to the month field is dependent on the current month (see [Table 29-3](#) for the day to month rollover schedule).
- Month – from 12/31 to 01/01, with a carry to the Year field
- Day of Week – from 6 to 0, without a carry (see [Table 29-2](#))
- Year – from 99 to 00, without a carry (this surpasses the intended use of the RTCC)

Considering that the following values are in BCD format, the carry to the upper BCD digit will occur at a count of 10, and not a count of 16 (SECONDS, MINUTES, HOURS, WEEKDAY, DAYS, MONTHS).

Table 29-2: Day of Week Schedule

Day of Week	
Sunday	0
Monday	1
Tuesday	2
Wednesday	3
Thursday	4
Friday	5
Saturday	6

Table 29-3: Day to Month Rollover Schedule⁽¹⁾

Month	Maximum Day Field
01 (January)	31
02 (February)	28 or 29 ⁽¹⁾
03 (March)	31
04 (April)	30
05 (May)	31
06 (June)	30
07 (July)	31
08 (August)	31
09 (September)	30
10 (October)	31
11 (November)	30
12 (December)	31

Note 1: See [29.3.5 “Leap Year”](#).

29.3.5 Leap Year

The year range on the RTCC module is from 2000 to 2099; therefore, the leap year calculation is determined by any year divisible by 4 in the above range. The only month to be affected in a leap year is February, which has 29 days, but only 28 days in all other years.

29.3.6 RTCC General Functionality

All timer registers containing a time value of seconds or greater are writable. The user can configure the current time by simply writing to these registers the desired year, month, day, hour, minutes and seconds. The timer will then use the newly written values to proceed with the count from the desired starting point.

Note that if the RTCC is enabled by setting the ON bit = 1 (RTCCON<15>), the timer will continue incrementing even while the registers are being adjusted. However, any time the seconds bit fields (RTCTIME<14:8>) are written, the prescaler is reset to '0'. This provides a known prescaler value after timer adjustments.

Section 29. Real-Time Clock and Calendar (RTCC)

If an update (CPU write) of the timer register occurs, it is the user's responsibility to ensure that when $ON = 1$ ($RTCCON<15>$), a timer increment will not occur to the registers that are being updated. This can be done by observing the value of the $RTCSYNC$ bit ($RTCCON<2>$), or the preceding digits from which a carry can occur, or by only updating the registers immediately following the seconds pulse (or alarm interrupt). Note that the corresponding counters are clocked based on their defined intervals (i.e., the days bit fields ($RTCDATE<13:8>$) are clocked once a day, the months bit fields ($RTCDATE<20:16>$) are only clocked once a month, etc). This leaves large windows of time in which registers can be safely updated.

The timer also provides visibility into the half-second field of the counter. However, this value is read-only and can only be reset by writing to the seconds bit fields ($RTCTIME<14:8>$).

29.3.7 Safety Window for Register Reads and Writes

The $RTCSYNC$ bit ($RTCCON<2>$) indicates a time window during which an update to the RTCC time registers ($RTCTIME$ and $RTCDATE$) is not imminent, and the registers can be safely read and written. When $RTCSYNC = 0$, the registers can be safely accessed by the CPU. When $RTCSYNC = 1$, the user must employ a firmware solution to assure that the data read did not fall on an update boundary, resulting in an invalid or partial read.

The $RTCSYNC$ bit is set 32 RTCC clock edges before an update is about to occur. It is cleared one clock later, after the update occurs (thus, $RTCSYNC$ is asserted for a total of 33 clocks).

Note that, independent of the $RTCSYNC$ value the user can, by reading and comparing a timer register value twice, ensure in code that the register read did not span an RTCC clock update.

Writes to the $ALRMTIME$ and $ALRMDATE$ registers should not be performed when $RTCSYNC = 1$. This restriction exists for two reasons:

1. A write could cause a timing violation in the alarm match logic, leading to an invalid alarm event and a corruption of the $ARPT$ register. This event can occur during the low time of an RTCC clock, following a rollover event.
2. A write during a rollover event, when the RTCC clock is high, will be ignored by hardware.

Example 29-1: Updating the RTCC Time and Date

```
/* The following code example will update the RTCC time and date. */

/*assume the secondary oscillator is enabled and ready, i.e. OSCCON<1>=1, OSCCON<22>=1,
and RTCC write is enabled i.e. RTCWREN (RTCCON<3>) =1;*/

unsigned long time=0x04153300;// set time to 04 hr, 15 min, 33 sec
unsigned long date=0x06102705;// set date to Friday 27 Oct 2006

RTCCONCLR=0x8000;           // turn off the RTCC
while(RTCCON&0x40);        // wait for clock to be turned off
RTCTIME=time;              // safe to update the time
RTCDATE=date;              // update the date
RTCCONSET=0x8000;          // turn on the RTCC
while(!(RTCCON&0x40));     // wait for clock to be turned on

// can disable the RTCC write
```

Example 29-2: Updating the RTCC Time Using the $RTCSYNC$ Window

```
/* The following code example will update the RTCC time and date. */

/*assume RTCC write is enabled i.e. RTCWREN (RTCCON<3>) =1; */

unsigned long time=0x04153300;// set time to 04 hr, 15 min, 33 sec
unsigned long date=0x06102705;// set date to Friday 27 Oct 2006

asm volatile ("di");       // disable interrupts, critical section follows
while((RTCCON&0x4)!=0);    // wait for not RTCSYNC
RTCTIME=time;              // safe to update the time
RTCDATE=date;              // update the date
asm volatile ("ei");       // restore interrupts, critical section ended

// can disable the RTCC write
```

29.3.8 Synchronization

The RTCC module provides a single RTCSYNC bit (RTCCON<2>) that the user must use to determine when it is safe to read and update the time and date registers. In addition, the RTCC module provides synchronization for reset conditions (i.e., a write to the seconds bit fields (RTCTIME<14:8>)), and for the ON bit (RTCCON<15>).

29.3.8.1 RTCSYNC BIT GENERATION

The RTCSYNC bit is a read-only bit that is set when ON = 1 and the RTCC Prescaler counter equals 0x7FE0 (32 clocks away from a one-second rollover). Logic clears the RTCSYNC bit for any of the following conditions:

- On a Power-on Reset (POR)
- Whenever the ON bit = 0
- On a write to the seconds bit fields (RTCTIME<14:8>)
- On the rising edge of the RTCC clock, when the prescaler is 0x0000

The RTCSYNC bit timings are illustrated in [Figure 29-5](#).

Figure 29-5: RTCSYNC Timing

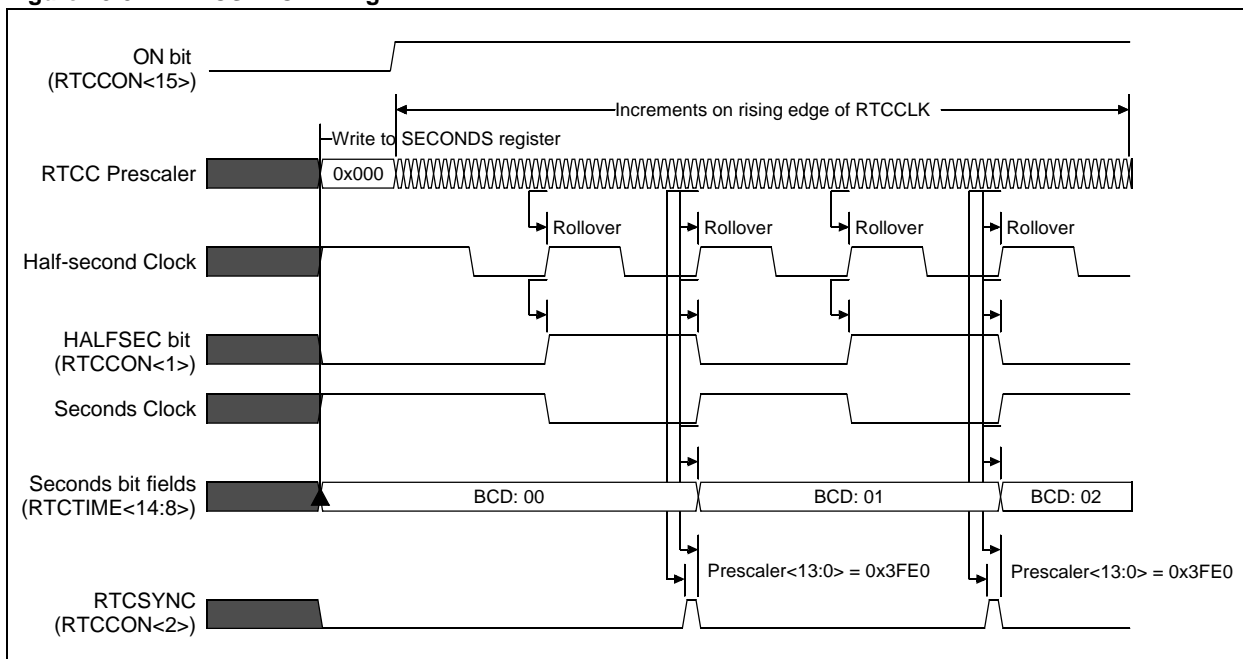

29.3.8.2 PRESCALER RESET SYNCHRONIZATION

A write to the seconds bit fields (RTCTIME<14:8>) asynchronously resets the RTCC Prescaler (including the HALFSEC bit (RTCCON<1>)). The Reset remains active until a falling edge of the RTCC clock is detected, as illustrated in [Figure 29-6](#).

Figure 29-6: Prescaler Synchronization to SECONDS Register Write

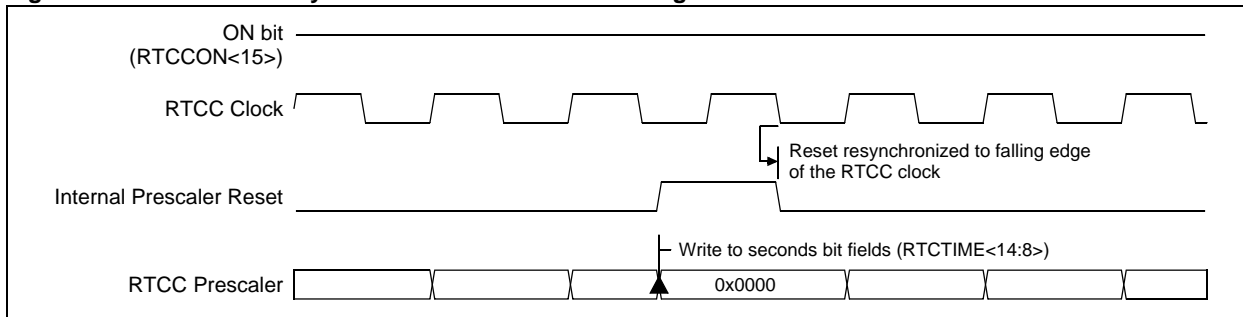

Section 29. Real-Time Clock and Calendar (RTCC)

29.3.8.3 MASKING OFF THE RTCC CLOCK

To mask off the RTCC clock, set the ON bit (RTCCON<15>) to '0'. Stopping the RTCC clock does not affect reading and writing registers from the peripheral bus interface.

29.3.9 Write Lock

In order to perform a write to any of the RTCC timer registers, the RTCWREN bit (RTCCON<3>) must be set. Setting of the RTCWREN bit is only allowed once the device level unlocking sequence has been executed. The unlocking sequence is as follows:

1. Load 0xAA996655 to CPU register X.
2. Load 0x556699AA to CPU register Y.
3. Load 0x00000008 to CPU register Z (the RTCWREN bit number).
4. Suspend or disable all Initiators that can access the Peripheral Bus and interrupt the unlock sequence. (i.e., DMA and Interrupts).
5. Store CPU register X to SYSKEY.
6. Store CPU register Y to SYSKEY.
7. Store CPU register Z to RTCCONSET.
8. Re-enable DMA and interrupts.

See [Example 29-3](#) for an assembly language implementation of the Write Unlock operation.

Note: Steps 5 through 7 must be followed exactly to unlock RTCC write operations. If the sequence is not followed exactly, the RTCWREN bit will not be set.

Example 29-3: Write Unlock Sequence

```
# assume interrupts are disabled
# assume the DMA controller is suspended
# assume the device is locked

#starting critical sequence
SYSKEY = 0xaa996655; // write first unlock key to SYSKEY
SYSKEY = 0x556699aa; // write second unlock key to SYSKEY
RTCCONSET = 0x8; // set RTCWREN in RTCCONSET
#end critical sequence

# re-enable interrupts
# re-enable the DMA controller
```

Note: To avoid accidental writes to the RTCC time values, it is recommended that the RTCWREN bit (RTCCON<3>) is kept clear at any other time. For RTCWREN bit to be set, there is only one instruction cycle time window allowed between the key1, key2 sequence and the setting of RTCWREN bit. Therefore, it is recommended to follow the code in [Example 29-3](#).

29.3.10 Calibration

The real-time crystal input can be calibrated using the periodic auto-adjust feature. When properly calibrated, the RTCC can provide an error of less than 0.66 seconds per month. Calibration has the ability to eliminate an error of up to 260 ppm.

The calibration is accomplished by finding the number of error clock pulses and writing this value into the calibration bit fields (RTCCON<9:0>). This 10-bit signed value will be either added or subtracted from the RTCC timer once every minute. Use the following procedure for RTCC calibration:

1. Using another timer resource on the device, the user must find the error of the 32.768 kHz crystal.
2. Once the error is known, it must be converted to the number of error clock pulses per minute, as shown in [Equation 29-1](#).

Equation 29-1: Calculating Error Clocks Per Minute

$$(Ideal\ Frequency\ (32,758) - Measured\ Frequency) * 60 = Error\ Clocks\ per\ Minute$$

3. Based on the result from step 2, the following options are available:
 - a) If the oscillator is *faster* than ideal (negative result from step 2), the calibration bit fields (RTCCON<9:0>) value needs to be negative. This causes the specified number of clock pulses to be subtracted from the timer counter once every minute.
 - b) If the oscillator is *slower* than ideal (positive result from step 2), the calibration bit fields (RTCCON<9:0>) value needs to be positive. This causes the specified number of clock pulses to be added to the timer counter once every minute.
4. Load the calibration bit fields (RTCCON<9:0>) with the correct value.

Writes to the calibration bit fields (RTCCON<9:0>) should only occur when the timer is turned off, or immediately after the rising edge of the seconds pulse (except when the seconds bit fields (RTCTIME<14:8>) are 0x00, due to the possibility of the auto-adjust event).

Notes: It is up to the user to include in the error value the initial error of the crystal, drift due to temperature, and drift due to crystal aging.

A write to the SECONDS register resets the state of calibration (not its value). If an adjustment just occurred, it will occur again because of the minute rollover.

Example 29-4: Updating the RTCC Calibration Value

```
/* The following code example will update the RTCC calibration. */

int cal=0x3FD;           // 10 bits adjustment, -3 in value

if(RTCCON&0x8000)
{
    // RTCC is ON
    unsigned int t0, t1;
    do
    {
        t0=RTCTIME;
        t1=RTCTIME;
    }while(t0!=t1);      // read valid time value
    if((t0&0xFF)==00)
    {
        // we're at second 00, wait auto-adjust to be performed
        while(!(RTCCON&0x2)); // wait until second half...
    }
}

RTCCONCLR=0x03FF0000;   // clear the calibration
RTCCONSET=cal;
```

29.4 ALARM

The RTCC module provides an alarm function with the following features:

- Configurable from a half-second to one year
- Enabled using the ALRMEN bit (RTCALRM<15>)
- One-time alarm, repeat alarms, and indefinite repetition of the alarm

29.4.1 Configuring the Alarm

The alarm feature is enabled using the ALRMEN bit.

The interval selection is made based on the settings of the Alarm Mask bits, AMASK<3:0> (RTCALRM<11:8>). The AMASK<3:0> bits determine which and how many digits of the alarm must match the clock value for the alarm to occur, as illustrated in [Figure 29-7](#).

Note: Once the timer value reaches the alarm setting, one RTCC clock period will elapse prior to setting the alarm interrupt. The result is that, for a short period, the user will see the timer value at the alarm setting without the interrupt having occurred.

29.4.1.1 CONFIGURING THE ONE-TIME ALARM

When the alarm is issued, with the ARPT bit = 0 (RTCALRM<7:0>) and the CHIME bit = 0 (RTCALRM<14>), the ALRMEN bit automatically clears.

Example 29-5: Configuring the RTCC for a One-Time One-Per-Day Alarm

```
/*
The following code example will update the RTCC one-time alarm.
Assumes the interrupts are disabled.
*/

unsigned long alTime=0x16153300;// set time to 04 hr, 15 min, 33 sec
unsigned long alDate=0x06102705;// set date to Friday 27 Oct 2006

// turn off the alarm, chime and alarm repeats; clear
// the alarm mask

while(RTCALRM&0x1000); // wait ALRMSYNC to be off
RTCALRMCLR=0xCFFF; // clear ALRMEN, CHIME, AMASK and ARPT;
ALRMTIME=alTime;
ALRMDATE=alDate; // update the alarm time and date

RTCALRMSET=0x8000|0x00000600; // re-enable the alarm, set alarm mask at once per day
```

29.4.1.2 CONFIGURING THE REPEAT ALARM

In addition to providing a one-time alarm, the RTCC module can be configured to repeat the alarm at a preconfigured interval. The ARPT<7:0> bits (RTCALRM<7:0>) contain the number of times the alarm repeats after the alarm is enabled. When ARPT<7:0> = 0 and CHIME = 0, the repeat function is disabled and only a single alarm pulse will be produced. The alarm can be generated up to 256 times by setting ARPT<7:0> = 0xFF.

Each time, after the alarm is issued, the ARPT<7:0> bits are decremented by one. Once they reach '0', the alarm will be generated one last time; after which point, ALRMEN bit is cleared automatically and the alarm will turn off.

Example 29-6: Configuring the RTCC for a Ten-Times One-Per-Hour Alarm

```
/*
The following code example will update the RTCC repeat alarm.
Assumes the interrupts are disabled.
*/

    unsigned long alTime=0x23352300; // set time to 23hr, 35 min, 23 sec
    unsigned long alDate=0x06111301; // set date to Monday 13 Nov 2006

                                // turn off the alarm, chime and alarm repeats; clear
                                // the alarm mask
while(RTCALRM&0x1000);          // wait ALRMSYNC to be off
RTCALRMCLR=0xCFFF;             // clear the ALRMEN, CHIME, AMASK and ARPT;
ALRMTIME=alTime;
ALRMDATE=alDate;               // update the alarm time and date
RTCALRMSET=0x8000|0x0509;      // re-enable the alarm, set alarm mask at once per hour
                                // for 10 times repeat
```

29.4.1.3 CONFIGURING THE INDEFINITE ALARM

To provide an indefinite repetition of the alarm, the Chime feature can be enabled using the CHIME bit (RTCALRM<14>). When CHIME = 1, rather than disabling the alarm when the last repeat has been performed, the ARPT<7:0> bits (RTCALRM<7:0>) rollover from 0x00 to 0xFF and continue counting indefinitely.

Example 29-7: Configuring the RTCC for Indefinite One-Per-Day Alarm

```
/*
The following code example will update the RTCC indefinite alarm.
Assumes the interrupts are disabled.
*/

    unsigned long alTime=0x23352300; // set time to 23hr, 35 min, 23 sec
    unsigned long alDate=0x06111301; // set date to Monday 13 Nov 2006

                                // turn off the alarm, chime and alarm repeats; clear
                                // the alarm mask
while(RTCALRM&0x1000);          // wait ALRMSYNC to be off
RTCALRMCLR=0xCFFF;             // clear ALRMEN, CHIME, AMASK, ARPT;
ALRMTIME=alTime;
ALRMDATE=alDate;               // update the alarm time and date
RTCALRMSET=0xC600;             // re-enable the alarm, set alarm mask at once per
                                // hour, enable CHIME
```

Section 29. Real-Time Clock and Calendar (RTCC)

Figure 29-7: Alarm Mask Settings

Alarm Mask Setting AMASK<3:0>	Day of the Week	Month	Day	Hours	Minutes	Seconds
0000 – Every half second	<input type="checkbox"/>	<input type="checkbox"/> <input type="checkbox"/> /	<input type="checkbox"/> <input type="checkbox"/>	<input type="checkbox"/> <input type="checkbox"/> :	<input type="checkbox"/> <input type="checkbox"/> :	<input type="checkbox"/> <input type="checkbox"/>
0001 – Every second	<input type="checkbox"/>	<input type="checkbox"/> <input type="checkbox"/> /	<input type="checkbox"/> <input type="checkbox"/>	<input type="checkbox"/> <input type="checkbox"/> :	<input type="checkbox"/> <input type="checkbox"/> :	<input type="checkbox"/> <input type="checkbox"/>
0010 – Every 10 seconds	<input type="checkbox"/>	<input type="checkbox"/> <input type="checkbox"/> /	<input type="checkbox"/> <input type="checkbox"/>	<input type="checkbox"/> <input type="checkbox"/> :	<input type="checkbox"/> <input type="checkbox"/> :	<input type="checkbox"/> s
0011 – Every minute	<input type="checkbox"/>	<input type="checkbox"/> <input type="checkbox"/> /	<input type="checkbox"/> <input type="checkbox"/>	<input type="checkbox"/> <input type="checkbox"/> :	<input type="checkbox"/> <input type="checkbox"/> :	<input type="checkbox"/> s <input type="checkbox"/> s
0100 – Every 10 minutes	<input type="checkbox"/>	<input type="checkbox"/> <input type="checkbox"/> /	<input type="checkbox"/> <input type="checkbox"/>	<input type="checkbox"/> <input type="checkbox"/> :	<input type="checkbox"/> m :	<input type="checkbox"/> s <input type="checkbox"/> s
0101 – Every hour	<input type="checkbox"/>	<input type="checkbox"/> <input type="checkbox"/> /	<input type="checkbox"/> <input type="checkbox"/>	<input type="checkbox"/> <input type="checkbox"/> :	<input type="checkbox"/> m <input type="checkbox"/> m :	<input type="checkbox"/> s <input type="checkbox"/> s
0110 – Every day	<input type="checkbox"/>	<input type="checkbox"/> <input type="checkbox"/> /	<input type="checkbox"/> <input type="checkbox"/>	<input type="checkbox"/> h <input type="checkbox"/> h :	<input type="checkbox"/> m <input type="checkbox"/> m :	<input type="checkbox"/> s <input type="checkbox"/> s
0111 – Every week	<input type="checkbox"/> d	<input type="checkbox"/> <input type="checkbox"/> /	<input type="checkbox"/> <input type="checkbox"/>	<input type="checkbox"/> h <input type="checkbox"/> h :	<input type="checkbox"/> m <input type="checkbox"/> m :	<input type="checkbox"/> s <input type="checkbox"/> s
1000 – Every month	<input type="checkbox"/>	<input type="checkbox"/> <input type="checkbox"/> /	<input type="checkbox"/> d <input type="checkbox"/> d	<input type="checkbox"/> h <input type="checkbox"/> h :	<input type="checkbox"/> m <input type="checkbox"/> m :	<input type="checkbox"/> s <input type="checkbox"/> s
1001 – Every year ⁽¹⁾	<input type="checkbox"/>	<input type="checkbox"/> m <input type="checkbox"/> m /	<input type="checkbox"/> d <input type="checkbox"/> d	<input type="checkbox"/> h <input type="checkbox"/> h :	<input type="checkbox"/> m <input type="checkbox"/> m :	<input type="checkbox"/> s <input type="checkbox"/> s

Note 1: Annually, except when configured for February 29 (leap year).

29.4.2 Alarm Interrupt

The alarm event is generated when the RTCC timer matches the alarm registers. The match must only occur on the unmasked portion of the time/date registers, according to the settings of the AMASK<3:0> bits (RTCALRM<11:8>), as illustrated in Figure 29-7.

At every alarm event, an interrupt is generated. In addition, an alarm pulse output is provided that operates at half the frequency of the alarm. This output is completely synchronous to the RTCC clock and can be used as a trigger clock to other peripherals. This output is available on the RTCC pin. The output pulse is a clock with a 50% duty cycle and a frequency half that of the alarm event, as illustrated in Figure 29-8. The alarm must be enabled for the pulse to be active, by setting the ALRMEN bit (RTCALRM<15>) = 1. The initial value of the alarm pulse at the RTCC output pin is programmable using the PIV bit (RTCALRM<13>).

The RTCC pin is also capable of outputting the seconds clock. The user can select between the alarm pulse, which is generated by the RTCC module, or the seconds clock output. The RTSECSEL bit (RTCCON<7>) selects between these two outputs. When RTSECSEL = 0, the alarm pulse is selected. When RTSECSEL = 1, the seconds clock is selected, as illustrated in Figure 29-9. Depending on the device, the RTCC pin can also output the RTCC clock, showing the exact clock the RTCC is using going into the prescaler.

Note: Changing any of the alarm time, date and alarm registers, other than the RTCOE bit (RTCCON<0>) while the alarm is enabled (ALRMEN = 1), can result in a false alarm event leading to a false alarm interrupt. To avoid a false alarm event and to perform a safe write to the alarm registers, the timer and alarm values should only be changed while the RTCC is disabled (RTCCON<15> = 0), or when the ALRMSYNC bit (RTCALRM<12>) = 0.

Figure 29-8: Alarm Event Generation

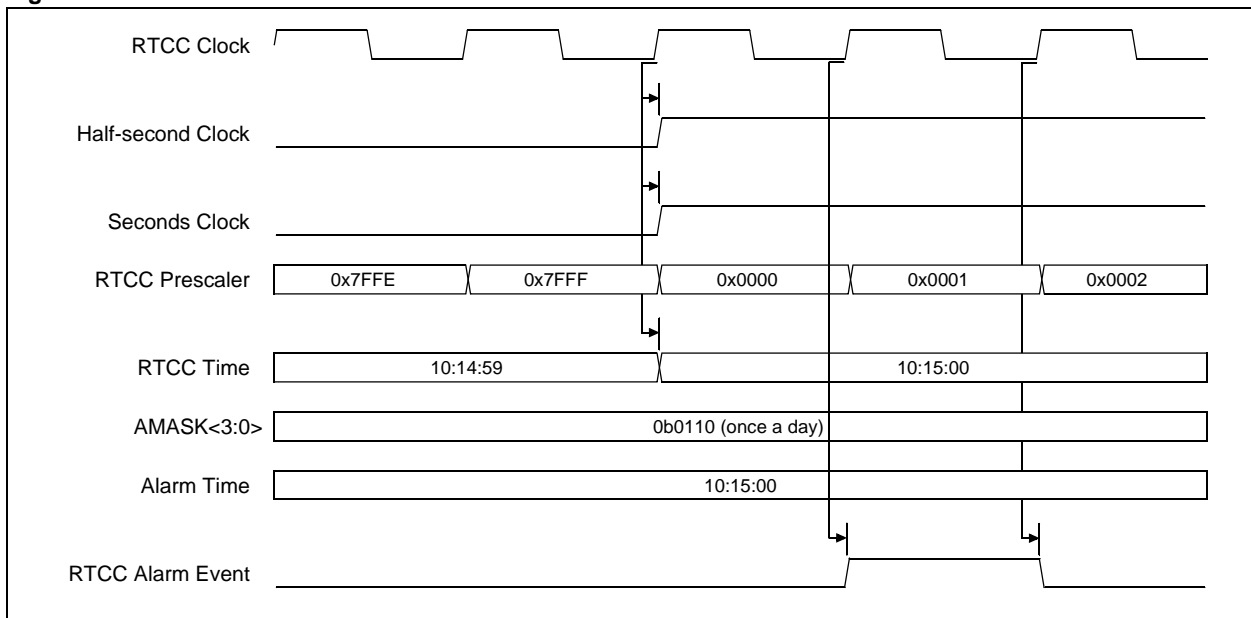
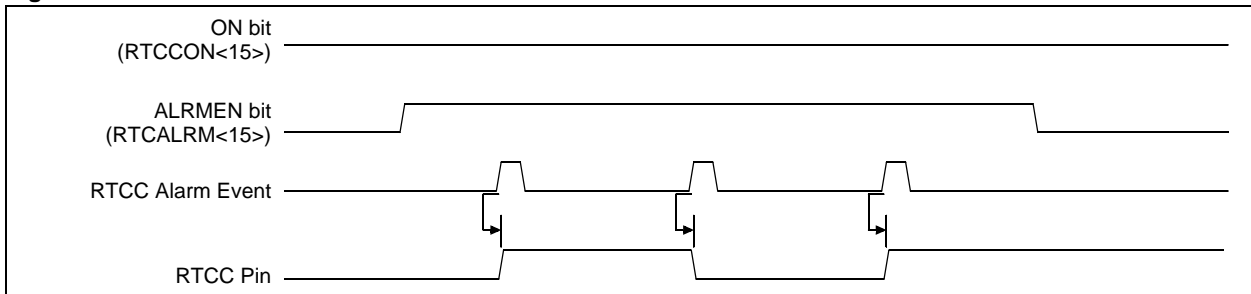

Figure 29-9: Alarm Pulse Generation



29.5 INTERRUPTS

The RTCC module has the ability to generate interrupts reflecting the alarm event that occurs when the RTCC timer matches the alarm registers. The match occurs on the unmasked portion of the time/date registers according to the settings of the AMASK<3:0> bits.

At every alarm event, an interrupt can be generated. The alarm interrupt is signalled by the RTCCIF bit. This interrupt flag must be cleared in software. To enable the RTCC interrupts, use the respective RTCC interrupt enable bit, RTCCIE. The interrupt priority level bits, RTCCIP<2:0>, and the interrupt subpriority level bits, RTCCIS<1:0>, must also be configured.

For more information, refer to the “**Interrupts**” chapter in the specific device data sheet and **Section 8. “Interrupts”** (DS61108) in the “*PIC32 Family Reference Manual*” for details on these bits and their actual register locations.

29.5.1 Interrupt Configuration

The RTCC module has one dedicated interrupt flag bit, RTCCIF, and a corresponding interrupt enable/mask bit, RTCCIE. RTCCIE is used to enable or disable the RTCC interrupt source. There is one specific RTCC interrupt vector.

The RTCCIF bit is set when the RTCC alarm registers match the RTCC time registers. The RTCCIF bit will be set without regard to the state of the corresponding enable bit. The RTCCIF bit can be polled by software if desired.

The RTCCIE bit is used to define the behavior of the Interrupts module when the corresponding RTCCIF bit is set. When the RTCCIE bit is clear, the Interrupts module does not generate a CPU interrupt for the event. If the RTCCIE bit is set, the Interrupts module will generate an interrupt to the CPU when the RTCCIF bit is set (subject to the priority and subpriority as outlined in the following paragraphs).

It is the responsibility of the user’s software routine that services a particular interrupt to clear the appropriate interrupt flag bit before the service routine is complete.

The priority of the RTCC peripheral can be set with the RTCCIP<2:0> bits (IPC8<28:26>). This priority defines the priority group to which the interrupt source will be assigned. The priority groups range from a value of 7 (the highest priority) to a value of 0 (which does not generate an interrupt). An interrupt being serviced will be preempted by an interrupt in a higher priority group.

The subpriority bits allow setting the priority of an interrupt source within a priority group. The values of the subpriority RTCCIS<1:0> bits, which range from 3 (the highest priority) to 0 (the lowest priority). An interrupt within the same priority group, but having a higher subpriority value, will not preempt a lower subpriority interrupt that is in progress.

The priority group and subpriority bits allow more than one interrupt source to share the same priority and subpriority. If simultaneous interrupts occur in this configuration, the natural order of the interrupt sources within a priority/subpriority group pair determine the interrupt generated. The natural priority is based on the vector numbers of the interrupt sources. The lower the vector number the higher the natural priority of the interrupt. Any interrupts that were overridden by natural order will then generate their respective interrupts based on priority, subpriority, and natural order after the interrupt flag for the current interrupt is cleared.

After an enabled interrupt is generated, the CPU will jump to the vector assigned to that interrupt. The vector number for the interrupt is the same as the natural order number. The CPU will then begin executing code at the vector address. The user’s code at this vector address should perform any application specific operations and clear the RTCCIF interrupt flag, and then exit. Refer to the vector address table details in **Section 8. “Interrupts”** (DS61108) for more information on interrupts.

Example 29-8: RTCC Initialization with Interrupts Enabled Code Example

```
/*
The following code example illustrates an RTCC initialization with interrupts enabled.
When the RTCC alarm interrupt is generated, the cpu will jump to the vector assigned to
RTCC interrupt.
*/
// assume RTCC write is enabled i.e. RTCWREN (RTCCON<3>) =1;*/
IEC1CLR=0x00008000; // disable RTCC interrupts

RTCCONCLR=0x8000; // turn off the RTCC
while(RTCCON&0x40); // wait for clock to be turned off

IFS1CLR=0x00008000; // clear RTCC existing event
IPC8CLR=0x1f000000; // clear the priority
IPC8SET=0x0d000000; // Set IPL=3, subpriority 1
IEC1SET=0x00008000; // Enable RTCC interrupts

RTCTIME=0x16153300; // safe to update time to 16 hr, 15 min, 33 sec
RTCDATE=0x06102705; // update the date to Friday 27 Oct 2006

RTCALRMCLR=0xCFFF; // clear ALRMEN, CHIME, AMASK and ARPT;
ALRMTIME=0x16154300; // set alarm time to 16 hr, 15 min, 43 sec
ALRMDATE=0x06102705; // set alarm date to Friday 27 Oct 2006

RTCALRMSET=0x8000|0x00000600; // re-enable the alarm, set alarm mask at once per day

RTCCONSET=0x8000; // turn on the RTCC
while(!(RTCCON&0x40)); // wait for clock to be turned on
```

Example 29-9: RTCC ISR Code Example

```
/*
The following code example demonstrates a simple interrupt service routine for RTCC
interrupts. The user's code at this vector should perform any application specific
operations and must clear the RTCC interrupt flag before exiting.
*/
void __ISR(_RTCC_VECTOR, ipl3) __RTCCInterrupt(void)
{
// ... perform application specific operations
// in response to the interrupt

IFS1CLR=0x00008000; // be sure to clear RTCC interrupt flag
// before exiting the service routine.
}
```

Note: The RTCC ISR code example shows MPLAB® C32 C compiler specific syntax. Refer to your compiler manual regarding support for ISRs.

29.6 OPERATION IN POWER-SAVING MODES

Note: Not all power-saving modes are available on all devices. Refer to the “Power-Saving Features” chapter in the specific device data sheet for availability.

29.6.1 RTCC Operation in Sleep Mode

When the device enters Sleep mode, the system clock is disabled. The RTCC and alarm continue to operate while in Sleep mode. The operation of the alarm is not affected by Sleep. An alarm event can wake-up the CPU if the alarm interrupt has a higher priority than the current CPU IPL.

29.6.2 RTCC Operation in Deep Sleep Mode

When the device enters Deep Sleep mode, the system clock is disabled. The RTCC and alarm continue to operate while in Deep Sleep. An alarm event can wake the CPU.

The alarm interrupt cannot be masked in Deep Sleep mode; therefore, it will wake the CPU when it triggers.

29.6.3 RTCC Operation in VBAT Mode

In PIC32 devices with VBAT power-saving features, the RTCC module is capable of continued operation during VBAT mode. While the alarm still functions, it will not wake the device. While in VBAT mode, the RTCC clock source selected by the RTCCCLKSEL<1:0> bits (RTCCON<10:9>) remains active.

Power must be applied to the VBAT pin for the RTCC module to continue operation. Refer to the “Power-Saving Features” chapter in the specific device data sheet and **Section 10. “Power-Saving Modes”** (DS61130) in the “PIC32 Family Reference Manual” for details.

29.6.4 RTCC Operation in Idle Mode

When the device enters Idle mode, the system clock sources remain functional. The RTCC and alarm continue to operate while in Idle mode. The operation of the alarm is not affected by Idle. An alarm event can wake-up the CPU if the alarm interrupt has a higher priority than the current CPU IPL.

The SIDL bit (RTCCON<13>) selects Idle mode behavior:

- If SIDL = 1, the PBCLK to the RTCC will be disabled

The PBCLK is the clock source for the AMASK bits (RTCALRM<11:8>), CHIME bit (RTCALRM<14>), ALRMTIME, ALRMDATE and all of the synchronizers that provide the read data for RTCTIME, and some other bits such as, ALRMSYNC (RTCALRM<12>), ALRMEN (RTCALRM<15>) and RTCSYNC (RTCCON<2>). Therefore, the SIDL functionality can be used to reduce the RTCC power consumption without affecting the functionality of the RTCC module.

- If SIDL = 0, the module will continue normal operation in Idle mode

29.7 EFFECTS OF VARIOUS RESETS

29.7.1 Device Reset

When a device Reset occurs, the RTCALRM register is forced to its reset state, causing the alarm to be disabled (if enabled prior to the reset). However, note that if the RTCC is enabled, it will continue to operate when a device Reset occurs.

29.7.2 Power-on Reset

The RTCTIME and RTCDATE registers are not affected by a Power-on Reset (POR). A POR forces the device to its inactive state. Once the device exits the POR state, the clock registers should be reloaded with the desired values.

The timer prescaler values can only be reset by writing to the seconds bit fields (RTCTIME<14:8>). No device Reset can affect the prescalers.

29.7.3 Watchdog Timer Reset

The Watchdog Timer Reset is equivalent to the device Reset.

29.7.4 Effects of the ON Bit

When the ON bit = 0 (RTCCON<15>), the RTCSYNC (RTCCON<2>), HALFSEC (RTCCON<1>) and ALRMSYNC bits (RTCALRM<4>) are asynchronously reset and held in reset. Also, the RTCC pin output is determined by the RTCOE bit (RTCCON<0>), which is masked by the ON bit.

29.7.5 MCLR Reset

The RTCC module and the Secondary Oscillator (SOSC) will continue to function when the device is held under reset by pulling the MCLR pin low.

Section 29. Real-Time Clock and Calendar (RTCC)

29.8 RELATED APPLICATION NOTES

This section lists application notes that are related to this section of the manual. These application notes may not be written specifically for the PIC32 device family, but the concepts are pertinent and could be used with modification and possible limitations. The current application notes related to the Real-Time Clock and Calendar (RTCC) module are:

Title	Application Note #
No related application notes at this time	N/A

Note: Visit the Microchip web site (www.microchip.com) for additional application notes and code examples for the PIC32 family of devices.

29.9 REVISION HISTORY

Revision A (October 2007)

This is the initial released version of the document.

Revision B (October 2007)

Updated document to remove Confidential status.

Revision C (April 2008)

Revised status to Preliminary; Revised U-0 to r-x.

Revision D (June 2008)

Revised Registers 29-1, bit 14; Revised Registers 29-26, 29-27, Footnote; Revised Examples 29-1 and 29-9; Change Reserved bits from "Maintain as" to "Write"; Added Note to ON bit (RTCCON Register).

Revision E (December 2010)

This revision includes the following changes:

- Sections:
 - Updated 29.7 "Effects of Various Resets" with the following point:
 - The RTCC and the Secondary Oscillator (SOSC) will continue to function when the device is held under reset by pulling the MCLR pin low.
 - Removed 29.9 "I/O Pin Control".
- Notes:
 - Added a Note at the beginning of the section, which provides information on complementary documentation.
- Registers:
 - Revised Register 29-1 through Register 29-6
 - All SET, CLR, and INV registers were removed
 - The IFS1, IEC1, and IPC8 registers were removed
- Minor changes to the text and formatting have been incorporated throughout the document

Revision F (August 2012)

This revision includes the following updates:

- The list of features were updated (see [29.1 "Introduction"](#))
- The RTCC block diagram was updated (see [Figure 29-1](#))
- The RTCOUTSEL<1:0> and RTCCLKSEL<1:0> bits were added and the FRZ bit was removed (see [Table 29-1](#) and [Register 29-1](#))
- [29.3.3 "Clock Source"](#) was updated
- [29.4.2 "Alarm Interrupt"](#) was updated
- [29.5 "Interrupts"](#) was updated
- [29.6.2 "RTCC Operation in Deep Sleep Mode"](#) was added
- [29.6.3 "RTCC Operation in VBAT Mode"](#) was added
- 29.6.3 "RTCC Operation in Debug Mode" was removed
- 29.8 "Peripherals Using the RTCC Module" was removed
- 29.9 "Design Tips" was removed
- Minor updates to text and formatting were incorporated throughout the document

Note the following details of the code protection feature on Microchip devices:

- Microchip products meet the specification contained in their particular Microchip Data Sheet.
- Microchip believes that its family of products is one of the most secure families of its kind on the market today, when used in the intended manner and under normal conditions.
- There are dishonest and possibly illegal methods used to breach the code protection feature. All of these methods, to our knowledge, require using the Microchip products in a manner outside the operating specifications contained in Microchip's Data Sheets. Most likely, the person doing so is engaged in theft of intellectual property.
- Microchip is willing to work with the customer who is concerned about the integrity of their code.
- Neither Microchip nor any other semiconductor manufacturer can guarantee the security of their code. Code protection does not mean that we are guaranteeing the product as "unbreakable."

Code protection is constantly evolving. We at Microchip are committed to continuously improving the code protection features of our products. Attempts to break Microchip's code protection feature may be a violation of the Digital Millennium Copyright Act. If such acts allow unauthorized access to your software or other copyrighted work, you may have a right to sue for relief under that Act.

Information contained in this publication regarding device applications and the like is provided only for your convenience and may be superseded by updates. It is your responsibility to ensure that your application meets with your specifications. MICROCHIP MAKES NO REPRESENTATIONS OR WARRANTIES OF ANY KIND WHETHER EXPRESS OR IMPLIED, WRITTEN OR ORAL, STATUTORY OR OTHERWISE, RELATED TO THE INFORMATION, INCLUDING BUT NOT LIMITED TO ITS CONDITION, QUALITY, PERFORMANCE, MERCHANTABILITY OR FITNESS FOR PURPOSE. Microchip disclaims all liability arising from this information and its use. Use of Microchip devices in life support and/or safety applications is entirely at the buyer's risk, and the buyer agrees to defend, indemnify and hold harmless Microchip from any and all damages, claims, suits, or expenses resulting from such use. No licenses are conveyed, implicitly or otherwise, under any Microchip intellectual property rights.

Trademarks

The Microchip name and logo, the Microchip logo, dsPIC, KEELOQ, KEELOQ logo, MPLAB, PIC, PICmicro, PICSTART, PIC³² logo, rPIC and UNI/O are registered trademarks of Microchip Technology Incorporated in the U.S.A. and other countries.

FilterLab, Hampshire, HI-TECH C, Linear Active Thermistor, MXDEV, MXLAB, SEEVAL and The Embedded Control Solutions Company are registered trademarks of Microchip Technology Incorporated in the U.S.A.

Analog-for-the-Digital Age, Application Maestro, chipKIT, chipKIT logo, CodeGuard, dsPICDEM, dsPICDEM.net, dsPICworks, dsSPEAK, ECAN, ECONOMONITOR, FanSense, HI-TIDE, In-Circuit Serial Programming, ICSP, Mindi, MiWi, MPASM, MPLAB Certified logo, MPLIB, MPLINK, mTouch, Omniscent Code Generation, PICC, PICC-18, PICDEM, PICDEM.net, PICkit, PICtail, REAL ICE, rLAB, Select Mode, Total Endurance, TSHARC, UniWinDriver, WiperLock and ZENA are trademarks of Microchip Technology Incorporated in the U.S.A. and other countries.

SQTP is a service mark of Microchip Technology Incorporated in the U.S.A.

All other trademarks mentioned herein are property of their respective companies.

© 2007-2012, Microchip Technology Incorporated, Printed in the U.S.A., All Rights Reserved.

 Printed on recycled paper.

ISBN: 978-1-62076-469-5

**QUALITY MANAGEMENT SYSTEM
CERTIFIED BY DNV
= ISO/TS 16949 =**

Microchip received ISO/TS-16949:2009 certification for its worldwide headquarters, design and wafer fabrication facilities in Chandler and Tempe, Arizona; Gresham, Oregon and design centers in California and India. The Company's quality system processes and procedures are for its PIC[®] MCUs and dsPIC[®] DSCs, KEELOQ[®] code hopping devices, Serial EEPROMs, microperipherals, nonvolatile memory and analog products. In addition, Microchip's quality system for the design and manufacture of development systems is ISO 9001:2000 certified.



MICROCHIP

Worldwide Sales and Service

AMERICAS

Corporate Office
2355 West Chandler Blvd.
Chandler, AZ 85224-6199
Tel: 480-792-7200
Fax: 480-792-7277
Technical Support:
<http://www.microchip.com/support>
Web Address:
www.microchip.com

Atlanta
Duluth, GA
Tel: 678-957-9614
Fax: 678-957-1455

Boston
Westborough, MA
Tel: 774-760-0087
Fax: 774-760-0088

Chicago
Itasca, IL
Tel: 630-285-0071
Fax: 630-285-0075

Cleveland
Independence, OH
Tel: 216-447-0464
Fax: 216-447-0643

Dallas
Addison, TX
Tel: 972-818-7423
Fax: 972-818-2924

Detroit
Farmington Hills, MI
Tel: 248-538-2250
Fax: 248-538-2260

Indianapolis
Noblesville, IN
Tel: 317-773-8323
Fax: 317-773-5453

Los Angeles
Mission Viejo, CA
Tel: 949-462-9523
Fax: 949-462-9608

Santa Clara
Santa Clara, CA
Tel: 408-961-6444
Fax: 408-961-6445

Toronto
Mississauga, Ontario,
Canada
Tel: 905-673-0699
Fax: 905-673-6509

ASIA/PACIFIC

Asia Pacific Office
Suites 3707-14, 37th Floor
Tower 6, The Gateway
Harbour City, Kowloon
Hong Kong
Tel: 852-2401-1200
Fax: 852-2401-3431

Australia - Sydney
Tel: 61-2-9868-6733
Fax: 61-2-9868-6755

China - Beijing
Tel: 86-10-8569-7000
Fax: 86-10-8528-2104

China - Chengdu
Tel: 86-28-8665-5511
Fax: 86-28-8665-7889

China - Chongqing
Tel: 86-23-8980-9588
Fax: 86-23-8980-9500

China - Hangzhou
Tel: 86-571-2819-3187
Fax: 86-571-2819-3189

China - Hong Kong SAR
Tel: 852-2401-1200
Fax: 852-2401-3431

China - Nanjing
Tel: 86-25-8473-2460
Fax: 86-25-8473-2470

China - Qingdao
Tel: 86-532-8502-7355
Fax: 86-532-8502-7205

China - Shanghai
Tel: 86-21-5407-5533
Fax: 86-21-5407-5066

China - Shenyang
Tel: 86-24-2334-2829
Fax: 86-24-2334-2393

China - Shenzhen
Tel: 86-755-8203-2660
Fax: 86-755-8203-1760

China - Wuhan
Tel: 86-27-5980-5300
Fax: 86-27-5980-5118

China - Xian
Tel: 86-29-8833-7252
Fax: 86-29-8833-7256

China - Xiamen
Tel: 86-592-2388138
Fax: 86-592-2388130

China - Zhuhai
Tel: 86-756-3210040
Fax: 86-756-3210049

ASIA/PACIFIC

India - Bangalore
Tel: 91-80-3090-4444
Fax: 91-80-3090-4123

India - New Delhi
Tel: 91-11-4160-8631
Fax: 91-11-4160-8632

India - Pune
Tel: 91-20-2566-1512
Fax: 91-20-2566-1513

Japan - Osaka
Tel: 81-66-152-7160
Fax: 81-66-152-9310

Japan - Yokohama
Tel: 81-45-471-6166
Fax: 81-45-471-6122

Korea - Daegu
Tel: 82-53-744-4301
Fax: 82-53-744-4302

Korea - Seoul
Tel: 82-2-554-7200
Fax: 82-2-558-5932 or
82-2-558-5934

Malaysia - Kuala Lumpur
Tel: 60-3-6201-9857
Fax: 60-3-6201-9859

Malaysia - Penang
Tel: 60-4-227-8870
Fax: 60-4-227-4068

Philippines - Manila
Tel: 63-2-634-9065
Fax: 63-2-634-9069

Singapore
Tel: 65-6334-8870
Fax: 65-6334-8850

Taiwan - Hsin Chu
Tel: 886-3-5778-366
Fax: 886-3-5770-955

Taiwan - Kaohsiung
Tel: 886-7-536-4818
Fax: 886-7-330-9305

Taiwan - Taipei
Tel: 886-2-2500-6610
Fax: 886-2-2508-0102

Thailand - Bangkok
Tel: 66-2-694-1351
Fax: 66-2-694-1350

EUROPE

Austria - Wels
Tel: 43-7242-2244-39
Fax: 43-7242-2244-393

Denmark - Copenhagen
Tel: 45-4450-2828
Fax: 45-4485-2829

France - Paris
Tel: 33-1-69-53-63-20
Fax: 33-1-69-30-90-79

Germany - Munich
Tel: 49-89-627-144-0
Fax: 49-89-627-144-44

Italy - Milan
Tel: 39-0331-742611
Fax: 39-0331-466781

Netherlands - Druenen
Tel: 31-416-690399
Fax: 31-416-690340

Spain - Madrid
Tel: 34-91-708-08-90
Fax: 34-91-708-08-91

UK - Wokingham
Tel: 44-118-921-5869
Fax: 44-118-921-5820

11/29/11