

Abstract

This application note presents various protection methods for Intersil's Overvoltage Protected (OVP) transceivers, also known as fault-protected transceivers.

Table of Contents

Introduction	2
Design Examples	2
Protection Scheme 1.....	3
Protection Scheme 2.....	4
Protection Scheme 3.....	4
Protection Scheme 4.....	4
Protection Scheme 5.....	4
Protection Scheme 6.....	5
Conclusion	6

List of Figures

FIGURE 1. Stand-Off Range of OVP Transceivers.....	2
FIGURE 2. Dual Foldback Characteristic of Current Limiter.....	2
FIGURE 3. V-I Characteristic of an OVP Transceiver's ESD Protection Circuit.....	2
FIGURE 4. Common-Mode Capacitance Over Data Rate	3
FIGURE 5. Surge Test Equivalent Circuit.....	3
FIGURE 6. RClamp0512TQ TVS for Unidirectional Transient Protecting Against 10A Surge Current per Line	3
FIGURE 7. V-I Characteristic of RClamp0512TQ	4
FIGURE 8. TClamp1202P TVS in Unidirectional Mode Protecting Against 50A Surge Current per Line	4
FIGURE 9. Two TClamp1202P Devices in Bidirectional Mode Protecting Against 100A Surge Current Over $\pm 12V$ CMVR	4
FIGURE 10. Two TClamp2482S Devices in Bidirectional Mode Protecting Against 30A Surge Current Over $\pm 20V$ CMVR.....	4
FIGURE 11. TClamp1202 and TClamp2482S Protecting Each Line Against 30A Surge Current Over $\pm 36V$ Voltage Range	5
FIGURE 12. V-I Characteristics of Protection Scheme 5	5
FIGURE 13. TClamp1202P and SMP100LC-25 Protecting Each Line Against 95A Surge Current Over $\pm 31V$ Voltage Range	5
FIGURE 14. V-I Characteristics of Protection Scheme 6	6

Introduction

OVP transceivers have bus I/O stages with high, symmetric stand-off capability of up to $\pm 60\text{V}$, thus providing protection against high DC potentials and transient voltages within that range (Figure 1).

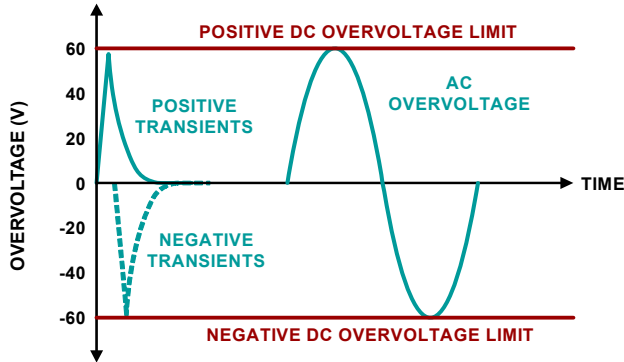

FIGURE 1. STAND-OFF RANGE OF OVP TRANSCEIVERS

DC faults often occur in applications where 24V DC supply lines share the same conduit with RS-485 data lines. Here sharp cable bends and crunched cables can cause breaks in the cable insulation, thus shorting supply and data lines.

Small transient voltages can result from nearby electronic equipment, inducing switching noise into the bus lines, and from clamping voltages of transient protection components.

The robustness of an OVP transceiver is accomplished with high stand-off voltage transistors and internal current limiting of the driver output stage. Since Intersil's OVP transceivers also support a wide Common-Mode Voltage Range (CMVR) of up to $\pm 25\text{V}$, the current limiter has a dual fold-back characteristic (Figure 2).

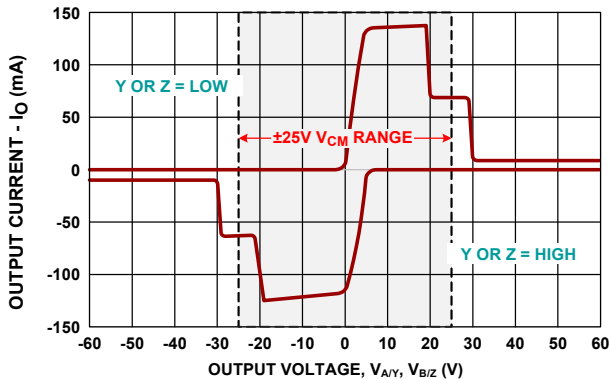

FIGURE 2. DUAL FOLDBACK CHARACTERISTIC OF CURRENT LIMITER

Dual foldback current limiting limits the power consumption of an active driver during a fault event, while enabling the driver to maintain operation across the wide CMVR.

In order to prevent the transceiver on-chip ESD protection from interfering with an external transient suppressor, the SCR trigger

voltage of an OVP transceiver lies far outside the $\pm 60\text{V}$ operating range (Figure 3).

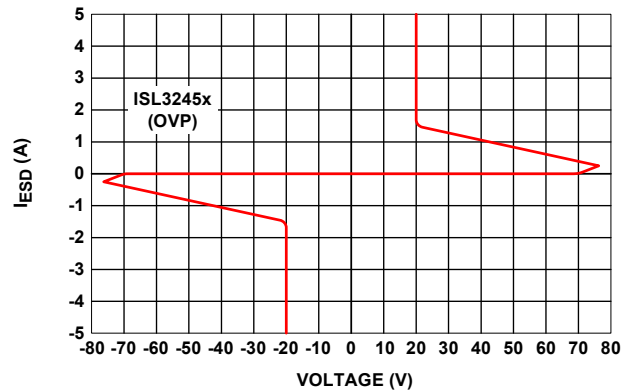

FIGURE 3. V-I CHARACTERISTIC OF AN OVP TRANSCEIVER'S ESD PROTECTION CIRCUIT

The symmetric protection range of an OVP transceiver is a major benefit for surge protection designs as it relieves designers from being limited to the one asymmetric clamping TVS device available on the market.

Designers can choose from a vast range of symmetrically clamping TVS devices with higher current capability and lower junction capacitance than the SM712.

Design Examples

The following transient protection schemes differ in CMVR, protection level, line-to-ground (common-mode) capacitance, and required board space.

While aiming for a high level of protection is important, another goal of transient protection design is keeping TVS capacitance as low as possible to minimize bus loading.

For applications with reduced CMVR, this is easily accomplished using low-capacitance TVS devices with small form factors that also consume less board space.

Applications with extended CMVR (such as $\pm 25\text{V}$) require components with high working voltages. Single protection devices with a high working voltage can have large junction capacitances, thus making them less attractive for consideration.

To reduce overall capacitance, a low-capacitance device can be connected in series with a high-capacitance device. The trade-off is a slight increase in board space.

Easing the assessment of how much data rate a protection scheme can support, Semtech's application team created a TVS capacitance versus data rate characteristic, shown as the green, single bus node line in Figure 4 on page 3.

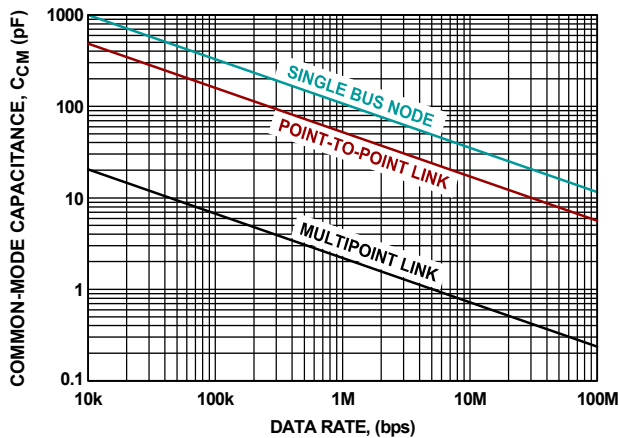

FIGURE 4. COMMON-MODE CAPACITANCE OVER DATA RATE

For any given data rate, the TVS capacitance, aka line-to-ground or common-mode capacitance, drops with an increase in bus nodes. While this characteristic does not include the connector and cable capacitances, it provides a good approximation of the maximum allowed capacitance of a protection scheme.

To quickly assess a circuit's maximum protection level and thus V_{PK} , use the simplified equivalent circuit of the surge test setup in Figure 5.

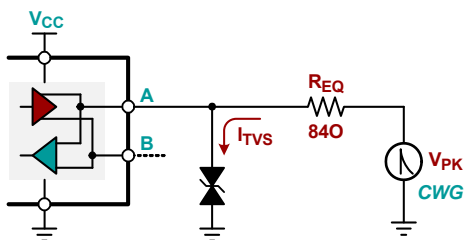

FIGURE 5. SURGE TEST EQUIVALENT CIRCUIT

Here, R_{EQ} is the equivalent source resistance of the surge generator of 84Ω . I_{TVS} is the TVS peak pulse current, derated for the transceiver's maximum operating temperature of $+85^\circ\text{C}$:

$$I_{TVS} = I_{PP} \cdot DF \quad (\text{EQ. 1})$$

I_{PP} is the TVS peak pulse current specified at $+25^\circ\text{C}$, and DF is the temperature derating factor. The peak generator voltage can thus be calculated with:

$$V_{PK} = I_{PP} \cdot DF \cdot R_{EQ} \quad (\text{EQ. 2})$$

While TVS datasheets often show derating curves for average power values, the derating factors for short pulses, such as the $8/20\mu\text{s}$ pulse, can be significantly higher. For example, the TVS diodes presented in this paper have an average power derating of 50% at $+85^\circ\text{C}$, while their actual pulse-power derating is 80%.

All following calculations therefore use an 80% derating, or $DF = 0.8$. Inserting the values for DF and R_{EQ} simplifies Equation 2:

$$V_{PK} = I_{PP} \cdot 67.2\Omega \quad (\text{EQ. 3})$$

Protection Scheme 1

The protection circuits in Figures 6 and 7 apply to data links without negative CMVR. Typical applications are Endat2.0 interfaces in shaft encoders of motor control systems. The Endat2.0 interface is a point-to-point link. Its interface cable of 300m maximum length includes DC power lines and RS-485 data lines. The DC ground line connects the local driver ground with the remote receiver ground, thus eliminating ground potential differences, while enabling the use of unidirectional, low-capacitance TVS diodes.

The circuit in Figure 6 presents a special case in our OVP discussion, as it uses a 100Mbps, standard transceiver. This example shows that applications with a unipolar common-mode range can use a standard transceiver and still be protected against IEC61000-4-5, Level 1 surge transients, if the correct protection device is selected. This is of particular importance as OVP transceivers with 100Mbps capability do not exist.

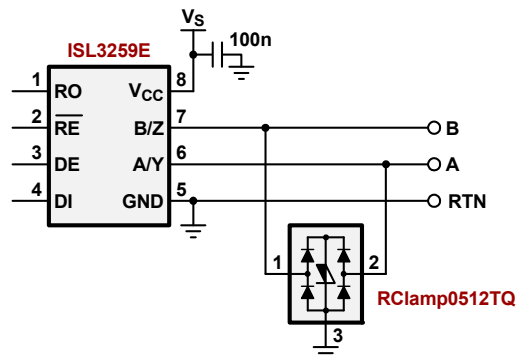

FIGURE 6. RClamp0512TQ TVS FOR UNIDIRECTIONAL TRANSIENT PROTECTING AGAINST 10A SURGE CURRENT PER LINE

To prevent the transceiver internal ESD from interfering with the switching characteristic of the external TVS, a thyristor device with snapback characteristic was chosen, whose breakover and clamping voltages are below the trigger threshold of the transceiver's ESD circuitry (Figure 7 on page 4).

The RClamp0512TQ is a 3pF, low-capacitance device with 5V stand-off (V_{RWM}), thus satisfying the 5V CMVR requirement. Its rated peak pulse current of 10A ($8/20\mu\text{s}$) per data line generates a clamping voltage of about 4V. Using Equation 3, the maximum protection level, V_{PK} , is calculated, yielding:

$$V_{PK} = 10A \times 67.2\Omega = 672V$$

This voltage exceeds the IEC61000-4-5, protection Level 1 of 500V. Also, the device line-to-ground capacitance of 3pF is well below the maximum value of 6pF suggested for a 100Mbps point-to-point link in Figure 4 on page 3.

Figure 7 shows the TVS V-I characteristic in comparison with the 5V CMVR and the 15V ESD trigger threshold of the ISL3259 transceiver.

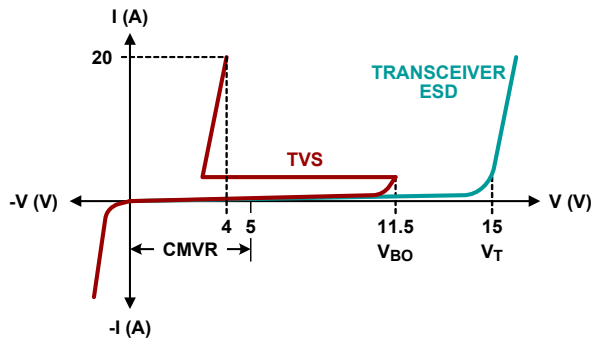

FIGURE 7. V-I CHARACTERISTIC OF RClamp0512TQ

Protection Scheme 2

Higher protection levels of applications with 5V CMVR demand more robust protection devices whose clamping voltages exceed the stand-off voltage range of standard transceivers. The circuit in [Figure 8](#) therefore uses the 20Mbps OVP transceiver, ISL32458E, in combination with Semtech's TClamp1202P.

The TClamp1202P is probably the most powerful and universal, 12V TVS on the market. The center TVS element has a working voltage of 12V and is rated for a peak pulse current of 100A. The device can be operated in unidirectional or bidirectional mode. In unidirectional mode, the device protects two data lines against surge currents of up to 50A each, while reaching a maximum clamping voltage of 40V. In this mode, its line-to-ground capacitance is 12pF, thus matching the recommended maximum for a 20Mbps, point-to-point link. Most impressive however, are the device's small package dimensions of 2mmx2mm.

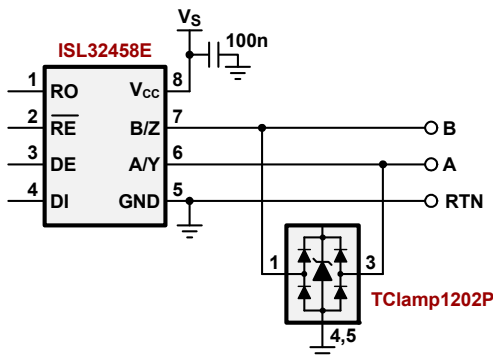

FIGURE 8. TClamp1202P TVS IN UNIDIRECTIONAL MODE PROTECTING AGAINST 50A SURGE CURRENT PER LINE

The circuit's maximum protection level is:

$V_{PK} = 50A \times 67.2\Omega = 3360V$, thus exceeding the IEC61000-4-5, protection Level 3 of 2000V.

Protection Scheme 3

The protection scheme in [Figure 9](#) protects a bus node over a $\pm 12V$ CMVR, slightly wider than the RS-485 standard common-mode range of -7V to 12V.

Here, the TClamp1202P is configured for bidirectional operation, protecting a single line. Its peak pulse current capability therefore increases to 100A, while its line-to-ground capacitance is reduced down to 6pF. Due to the additional diode drop in

bidirectional mode, the maximum clamping voltage is 52V, which is well below the transceiver stand-off voltage of 60V.

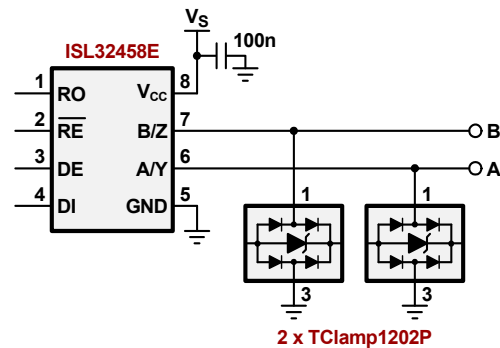

FIGURE 9. TWO TClamp1202P DEVICES IN BIDIRECTIONAL MODE PROTECTING AGAINST 100A SURGE CURRENT OVER $\pm 12V$ CMVR

The scheme's maximum protection level is:

$V_{PK} = 100A \times 67.2\Omega = 6.72kV$, reaching Level X in the IEC61000-4-5 scale of protection levels.

Protection Scheme 4

This protection scheme protects bus nodes over the extended CMVR of $\pm 20V$.

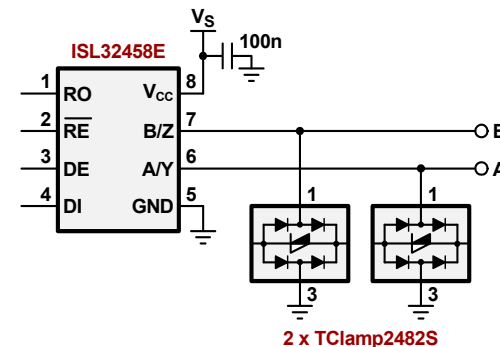

FIGURE 10. TWO TClamp2482S DEVICES IN BIDIRECTIONAL MODE PROTECTING AGAINST 30A SURGE CURRENT OVER $\pm 20V$ CMVR

The TClamp2482S has a snapback characteristic with a maximum V_{BO} of 35V and a typical V_C of 7.5V at 30A I_{PP} . Its maximum line-to-ground capacitance is an impressively low 1.8pF. The circuit's maximum protection level is:

$V_{PK} = 30A \times 67.2\Omega = 2016V$, providing IEC61000-4-5 Level 3 (2kV) surge protection.

Protection Scheme 5

In industrial automation, the 24V DC supply for analog and digital modules is commonly distributed through the same conduits as the RS-485 data lines. This introduces the risk of short-circuits between supply and data conductors in the case of insulation faults. The duration of these faults can last for minutes and days until their causes are eliminated.

To prevent TVS burnout due to a DC fault, its breakdown threshold must be higher than the maximum possible DC voltage. Since 24V supplies can experience excursion of up to

30V, transient protection schemes of RS-485 bus nodes must provide working voltages higher than that. At the same time, the maximum clamping voltage of the protection circuit must remain below the transceiver stand-off voltage of 60V. The protection scheme in [Figure 11](#) accomplishes both requirements by connecting a TVS (TClamp1202P) in series with a thyristor (TClamp2482S) to protect a single line.

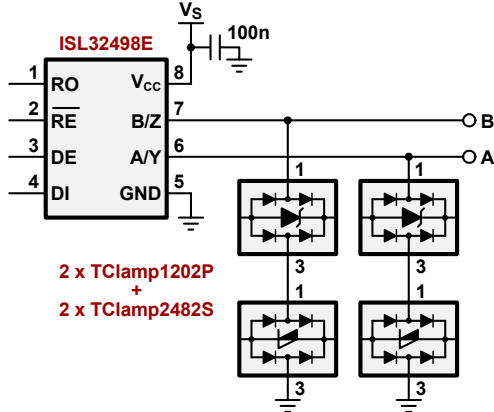

FIGURE 11. TClamp1202P AND TClamp2482S PROTECTING EACH LINE AGAINST 30A SURGE CURRENT OVER ±36V VOLTAGE RANGE

While it is easy to find device combinations that achieve the required working voltage, care must be applied that the sum of the TVS breakdown and the thyristor breakover voltage remain below the transceiver stand-off.

In the clamping region then, the TVS voltage continues to increase linearly with rising current, while the thyristor snaps back to a low-voltage level, which remains nearly constant up to the rated peak pulse current.

[Figure 12](#) shows the individual and combined V-I characteristics of the protection scheme. Here the combined, maximum clamping voltage is 38.5V.

While the TVS is able to conduct currents of up to 100A, the thyristor's rated peak pulse current of 30A represents the current limit of the combined solution. The maximum applicable surge test voltage is therefore:

$$V_{PK} = 30A \times 67.2\Omega = 2016V, \text{ attaining IEC61000-4-5 Level 3 (2kV) surge protection.}$$

The circuit's line-to-ground capacitance is made up by the 6pF between the data ports of the TClamp1202P in series with the 1.8pF between the data ports of the TClamp2482S, resulting in a total of 1.4pF.

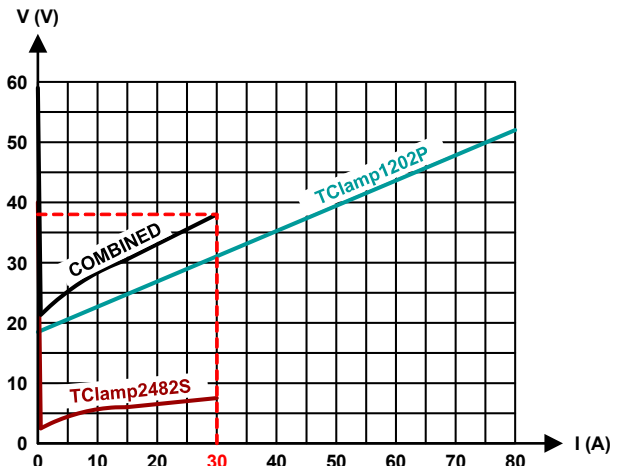

FIGURE 12. V-I CHARACTERISTICS OF PROTECTION SCHEME 5

Protection Scheme 6

To accomplish higher levels of protection, the circuit in [Figure 13](#) uses thyristors with much higher current ratings.

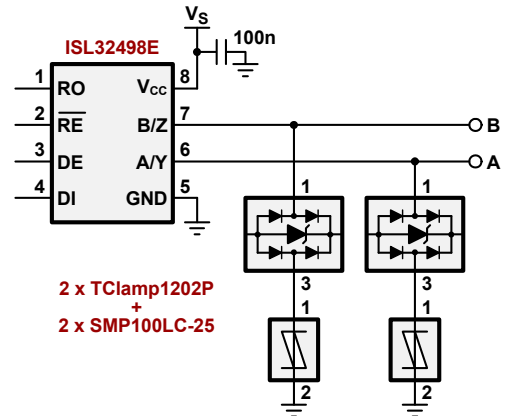

FIGURE 13. TClamp1202P AND SMP100LC-25 PROTECTING EACH LINE AGAINST 95A SURGE CURRENT OVER ±31V VOLTAGE RANGE

Here, the 400A (8/20μs) rated peak pulse current of the SMP100LC-25 supports the high current capability of the TClamp1202P, thus yielding a protection level of:

$$V_{PK} = 100A \times 67.2\Omega = 6.72kV$$

This represents Level X in the IEC61000-4-5 scale of protection levels.

Again, the low capacitance of the TClamp1202P in series with the 65pF of the SMP100LC-25 assures a low line-to-ground capacitance of only 5.5pF. [Figure 14 on page 6](#) shows the V-I characteristics of the solution, depicting a maximum clamping voltage of 56V at the derated current of 80A.

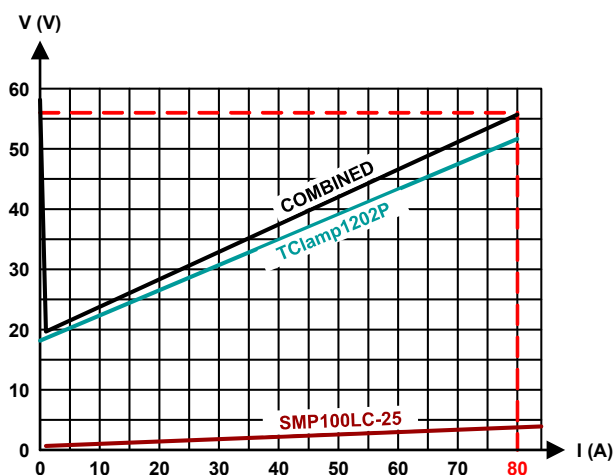

FIGURE 14. V-I CHARACTERISTICS OF PROTECTION SCHEME 6

Conclusion

Intersil OVP transceivers in combination with Semtech transient protection devices enable the fast and easy design of highly efficient protection circuits against ESD, EFT and surge transients.

The protection schemes presented in this application note are summarized in [Table 1](#).

All of these designs provide higher protection levels, higher reliability, lower capacitance and smaller board space than protection schemes using standard transceivers with MOVs, PTCs and GDTs, all of which have wear-out mechanisms and are subject to premature component failure.

Intersil's OVP transceiver portfolio is listed in [Table 2](#).

TABLE 1. PERFORMANCE SUMMARY OF PROTECTION SCHEMES

PROTECTION SCHEME	PROTECTION		STAND-OFF VOLTAGE (V)	LINE-GROUND CAPACITANCE (pF)	BOARD SPACE (mm ²)	TRANSCIVER FAMILY	PROTECTION DEVICES	MANUFACTURER
	LEVEL	VOLTAGE (kV)						
1	1	0.7	5	3	0.6	ISL3259E	RCLAMP0512TQ	SEMTECH
2	3	3.2	12	12	4	ISL3245xE	TCLAMP1202P	SEMTECH
3	X	6.7	±12	6	8		2 x TCLAMP1202P	SEMTECH
4	3	2.0	±24	1.8	16		TCLAMP2482S	SEMTECH
5	3	2.0	±36	1.4	24	ISL3249xE	2 x TCLAMP1202P + 2 x TCLAMP2482S	SEMTECH
6	X	6.7	±34	5.5	47		2 x TCLAMP1202P + 2 x SMP100LC-25	SEMTECH STM

TABLE 2. INTERSIL OVP TRANSCEIVER PORTFOLIO

DEVICE	OVP (V)	CMVR (V)	DATA RATE (MBPS)	HALF/FULL DUPLEX	HOT PLUG	PACKAGE
OVP TRANSCEIVERS WITH 3V TO 5V SUPPLY						
ISL32430E	±40	±15	0.25	Full	No	MSOP10, SOIC14
ISL32432E	±40	±15	0.25	Half	No	MSOP8, SOIC8
ISL32433E	±40	±15	1	Full	No	MSOP10, SOIC14
ISL32435E	±40	±15	1	Half	No	MSOP8, SOIC8
ISL32450E	±60	±20	0.25	Full	No	MSOP10, SOIC14
ISL32452E	±60	±20	0.25	Half	No	MSOP8, SOIC8
ISL32453E	±60	±20	1	Full	No	MSOP10, SOIC14
ISL32455E	±60	±20	1	Half	No	MSOP8, SOIC8
ISL32458E	±60	±20	20	Half	No	SOIC8

TABLE 2. INTERSIL OVP TRANSCEIVER PORTFOLIO (Continued)

DEVICE	OVP (V)	CMVR (V)	DATA RATE (MBPS)	HALF/FULL DUPLEX	HOT PLUG	PACKAGE
OVP TRANSCEIVERS WITH 5V SUPPLY AND HOT-PLUG CAPABILITY						
ISL32470E	±60	±15	0.25	Full	Yes	SOIC14
ISL32472E	±60	±15	0.25	Half	Yes	SOIC8
ISL32475E	±60	±15	1	Half	Yes	SOIC8
ISL32478E	±60	±15	15	Half	Yes	SOIC8
ISL32490E	±60	±25	0.25	Full	Yes	MSOP10, SOIC14
ISL32492E	±60	±25	0.25	Half	Yes	MSOP8, SOIC8
ISL32493E	±60	±25	1	Full	Yes	MSOP10, SOIC14
ISL32495E	±60	±25	1	Half	Yes	MSOP8, SOIC8
ISL32496E	±60	±25	15	Full	Yes	MSOP10, SOIC14
ISL32498E	±60	±25	15	Half	Yes	MSOP8, SOIC8
OVP TRANSCEIVERS WITH CABLE-INVERT FUNCTION						
ISL32437E (3V - 5V)	±40	±15	0.25	Half	No	MSOP8, SOIC8
ISL32457E (3V - 5V)	±60	±20	0.25	Half	No	MSOP8, SOIC8
ISL32459E (5V)	±60	±20	20	Half	No	SOIC8
ISL32483E (5V)	±60	±25	1	Full	Yes	SOIC14
ISL32485E (5V)	±60	±25	1	Half	Yes	SOIC8

Notice

1. Descriptions of circuits, software and other related information in this document are provided only to illustrate the operation of semiconductor products and application examples. You are fully responsible for the incorporation or any other use of the circuits, software, and information in the design of your product or system. Renesas Electronics disclaims any and all liability for any losses and damages incurred by you or third parties arising from the use of these circuits, software, or information.
2. Renesas Electronics hereby expressly disclaims any warranties against and liability for infringement or any other claims involving patents, copyrights, or other intellectual property rights of third parties, by or arising from the use of Renesas Electronics products or technical information described in this document, including but not limited to, the product data, drawings, charts, programs, algorithms, and application examples.
3. No license, express, implied or otherwise, is granted hereby under any patents, copyrights or other intellectual property rights of Renesas Electronics or others.
4. You shall not alter, modify, copy, or reverse engineer any Renesas Electronics product, whether in whole or in part. Renesas Electronics disclaims any and all liability for any losses or damages incurred by you or third parties arising from such alteration, modification, copying or reverse engineering.
5. Renesas Electronics products are classified according to the following two quality grades: "Standard" and "High Quality". The intended applications for each Renesas Electronics product depends on the product's quality grade, as indicated below.
"Standard": Computers; office equipment; communications equipment; test and measurement equipment; audio and visual equipment; home electronic appliances; machine tools; personal electronic equipment; industrial robots; etc.
"High Quality": Transportation equipment (automobiles, trains, ships, etc.); traffic control (traffic lights); large-scale communication equipment; key financial terminal systems; safety control equipment; etc.
Unless expressly designated as a high reliability product or a product for harsh environments in a Renesas Electronics data sheet or other Renesas Electronics document, Renesas Electronics products are not intended or authorized for use in products or systems that may pose a direct threat to human life or bodily injury (artificial life support devices or systems; surgical implantations; etc.), or may cause serious property damage (space system; undersea repeaters; nuclear power control systems; aircraft control systems; key plant systems; military equipment; etc.). Renesas Electronics disclaims any and all liability for any damages or losses incurred by you or any third parties arising from the use of any Renesas Electronics product that is inconsistent with any Renesas Electronics data sheet, user's manual or other Renesas Electronics document.
6. When using Renesas Electronics products, refer to the latest product information (data sheets, user's manuals, application notes, "General Notes for Handling and Using Semiconductor Devices" in the reliability handbook, etc.), and ensure that usage conditions are within the ranges specified by Renesas Electronics with respect to maximum ratings, operating power supply voltage range, heat dissipation characteristics, installation, etc. Renesas Electronics disclaims any and all liability for any malfunctions, failure or accident arising out of the use of Renesas Electronics products outside of such specified ranges.
7. Although Renesas Electronics endeavors to improve the quality and reliability of Renesas Electronics products, semiconductor products have specific characteristics, such as the occurrence of failure at a certain rate and malfunctions under certain use conditions. Unless designated as a high reliability product or a product for harsh environments in a Renesas Electronics data sheet or other Renesas Electronics document, Renesas Electronics products are not subject to radiation resistance design. You are responsible for implementing safety measures to guard against the possibility of bodily injury, injury or damage caused by fire, and/or danger to the public in the event of a failure or malfunction of Renesas Electronics products, such as safety design for hardware and software, including but not limited to redundancy, fire control and malfunction prevention, appropriate treatment for aging degradation or any other appropriate measures. Because the evaluation of microcomputer software alone is very difficult and impractical, you are responsible for evaluating the safety of the final products or systems manufactured by you.
8. Please contact a Renesas Electronics sales office for details as to environmental matters such as the environmental compatibility of each Renesas Electronics product. You are responsible for carefully and sufficiently investigating applicable laws and regulations that regulate the inclusion or use of controlled substances, including without limitation, the EU RoHS Directive, and using Renesas Electronics products in compliance with all these applicable laws and regulations. Renesas Electronics disclaims any and all liability for damages or losses occurring as a result of your noncompliance with applicable laws and regulations.
9. Renesas Electronics products and technologies shall not be used for or incorporated into any products or systems whose manufacture, use, or sale is prohibited under any applicable domestic or foreign laws or regulations. You shall comply with any applicable export control laws and regulations promulgated and administered by the governments of any countries asserting jurisdiction over the parties or transactions.
10. It is the responsibility of the buyer or distributor of Renesas Electronics products, or any other party who distributes, disposes of, or otherwise sells or transfers the product to a third party, to notify such third party in advance of the contents and conditions set forth in this document.
11. This document shall not be reprinted, reproduced or duplicated in any form, in whole or in part, without prior written consent of Renesas Electronics.
12. Please contact a Renesas Electronics sales office if you have any questions regarding the information contained in this document or Renesas Electronics products.
(Note 1) "Renesas Electronics" as used in this document means Renesas Electronics Corporation and also includes its directly or indirectly controlled subsidiaries.
(Note 2) "Renesas Electronics product(s)" means any product developed or manufactured by or for Renesas Electronics.

(Rev.4.0-1 November 2017)



SALES OFFICES

Renesas Electronics Corporation

<http://www.renesas.com>

Refer to "<http://www.renesas.com/>" for the latest and detailed information.

Renesas Electronics America Inc.
1001 Murphy Ranch Road, Milpitas, CA 95035, U.S.A.
Tel: +1-408-432-8888, Fax: +1-408-434-5351

Renesas Electronics Canada Limited
9251 Yonge Street, Suite 8309 Richmond Hill, Ontario Canada L4C 9T3
Tel: +1-905-237-2004

Renesas Electronics Europe Limited
Dukes Meadow, Millboard Road, Bourne End, Buckinghamshire, SL8 5FH, U.K
Tel: +44-1628-651-700, Fax: +44-1628-651-804

Renesas Electronics Europe GmbH
Arcadiastrasse 10, 40472 Düsseldorf, Germany
Tel: +49-211-6503-0, Fax: +49-211-6503-1327

Renesas Electronics (China) Co., Ltd.
Room 1709 Quantum Plaza, No.27 ZhichunLu, Haidian District, Beijing, 100191 P. R. China
Tel: +86-10-8235-1155, Fax: +86-10-8235-7679

Renesas Electronics (Shanghai) Co., Ltd.
Unit 301, Tower A, Central Towers, 555 Langao Road, Putuo District, Shanghai, 200333 P. R. China
Tel: +86-21-2226-0888, Fax: +86-21-2226-0999

Renesas Electronics Hong Kong Limited
Unit 1601-1611, 16/F., Tower 2, Grand Century Place, 193 Prince Edward Road West, Mongkok, Kowloon, Hong Kong
Tel: +852-2265-6688, Fax: +852-2886-9022

Renesas Electronics Taiwan Co., Ltd.
13F, No. 363, Fu Shing North Road, Taipei 10543, Taiwan
Tel: +886-2-8175-9600, Fax: +886-2-8175-9670

Renesas Electronics Singapore Pte. Ltd.
80 Bendemeer Road, Unit #06-02 Hyflux Innovation Centre, Singapore 339949
Tel: +65-6213-0200, Fax: +65-6213-0300

Renesas Electronics Malaysia Sdn.Bhd.
Unit 1207, Block B, Menara Amcorp, Amcorp Trade Centre, No. 18, Jln Persiaran Barat, 46050 Petaling Jaya, Selangor Darul Ehsan, Malaysia
Tel: +60-3-7955-9390, Fax: +60-3-7955-9510

Renesas Electronics India Pvt. Ltd.
No.777C, 100 Feet Road, HAL 2nd Stage, Indiranagar, Bangalore 560 038, India
Tel: +91-80-67208700, Fax: +91-80-67208777

Renesas Electronics Korea Co., Ltd.
17F, KAMCO Yangjae Tower, 262, Gangnam-daero, Gangnam-gu, Seoul, 06265 Korea
Tel: +82-2-558-3737, Fax: +82-2-558-5338