



User Manual

 **FERREX[®]**

TABLE SAW



Original instructions

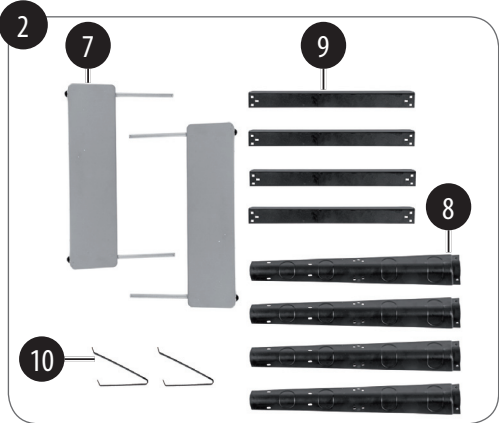
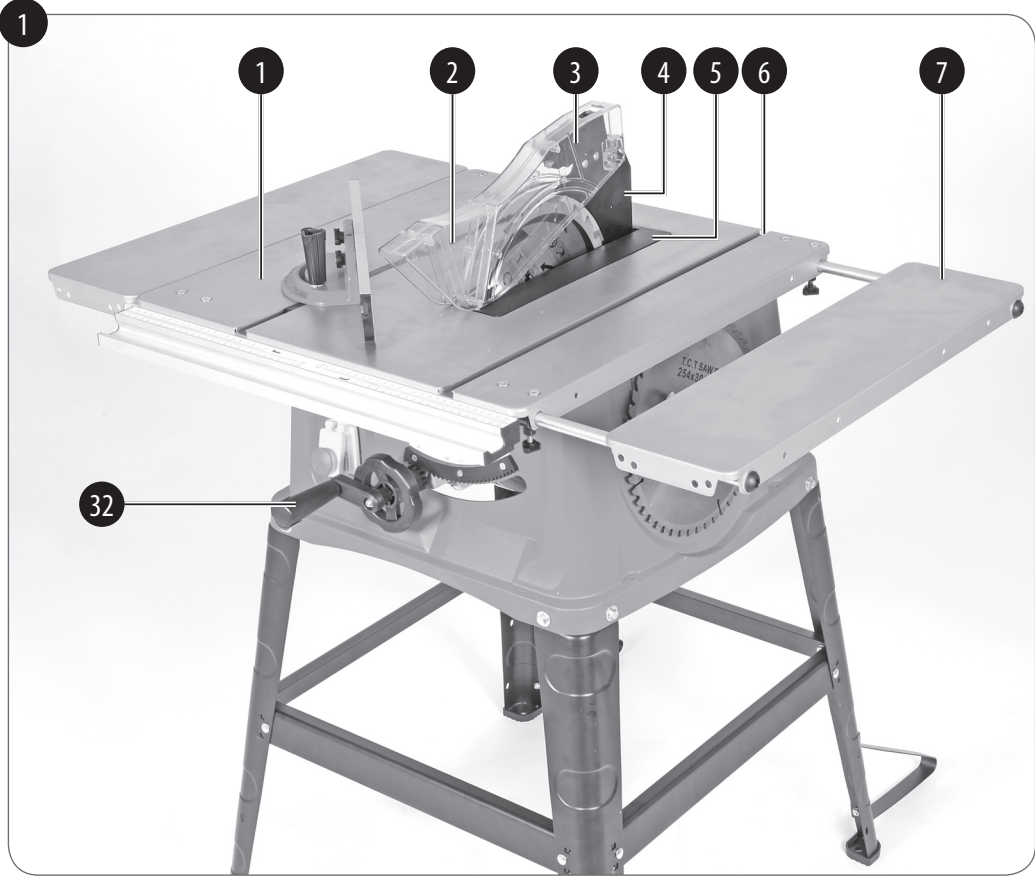

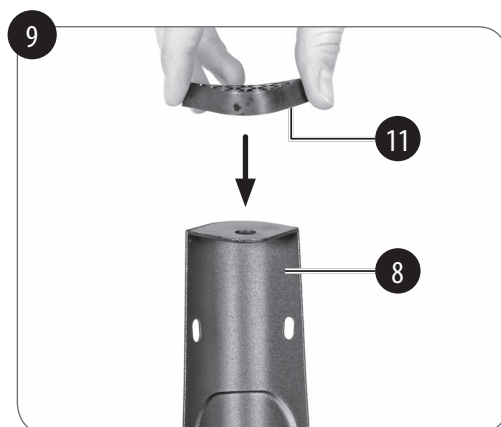
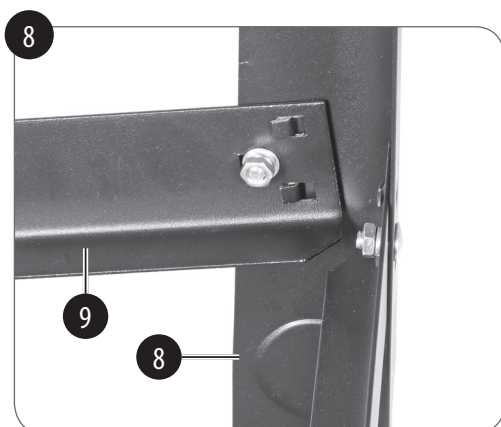
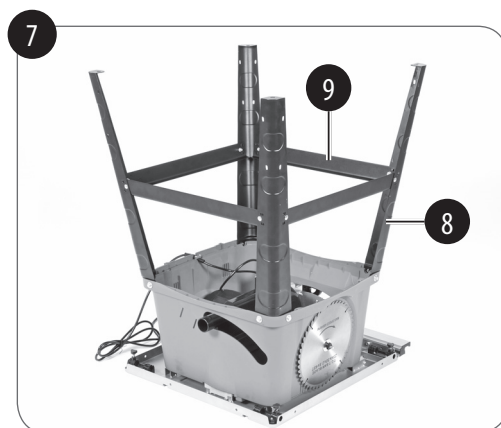
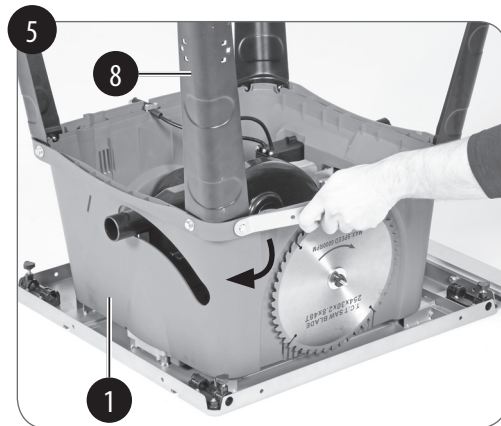
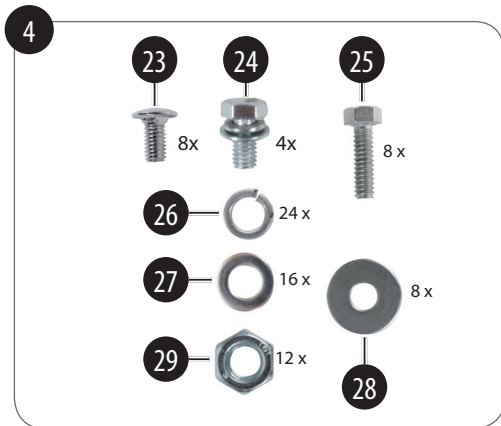

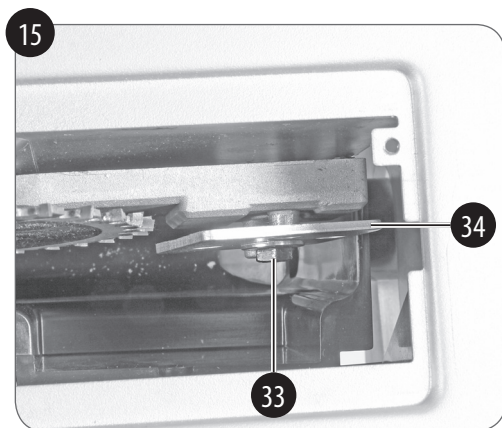
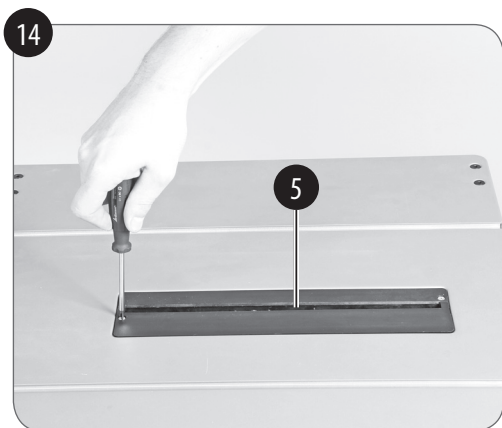
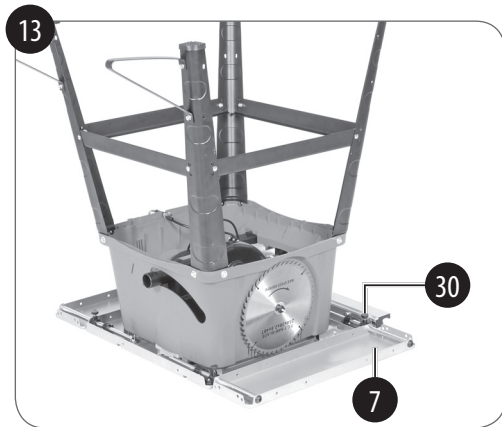
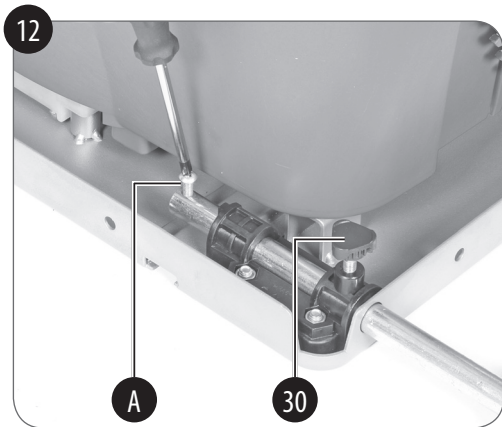
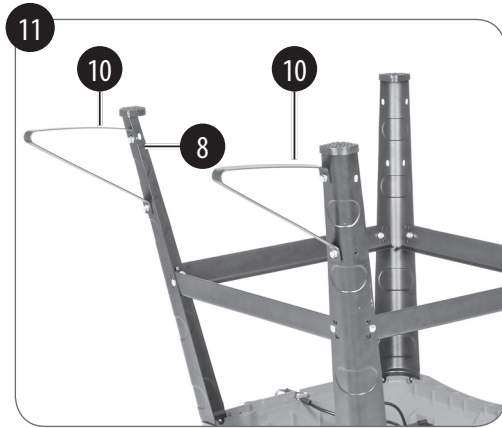
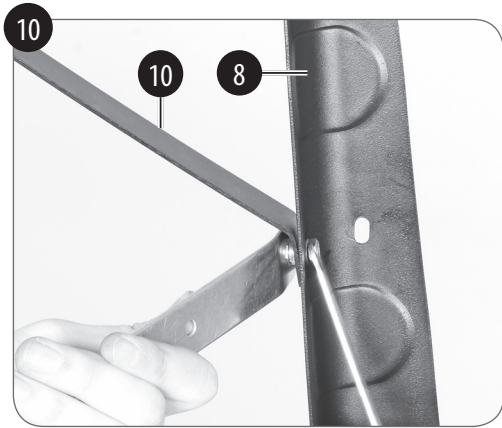

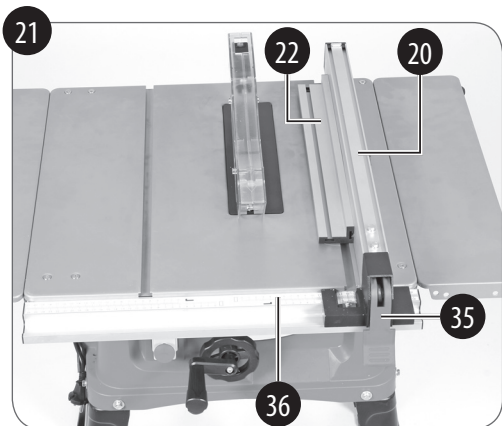
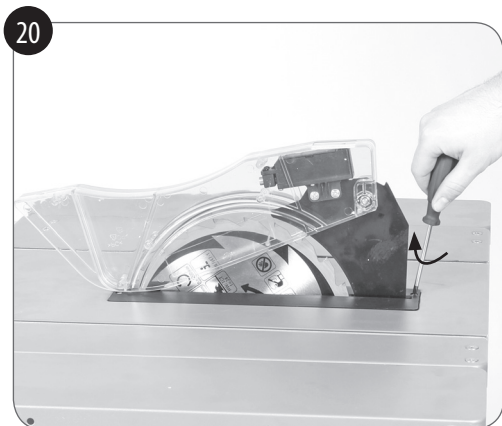
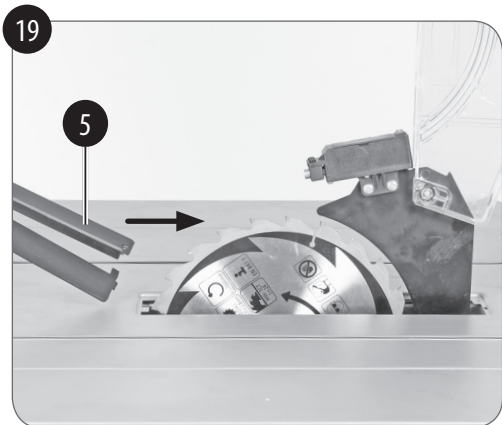
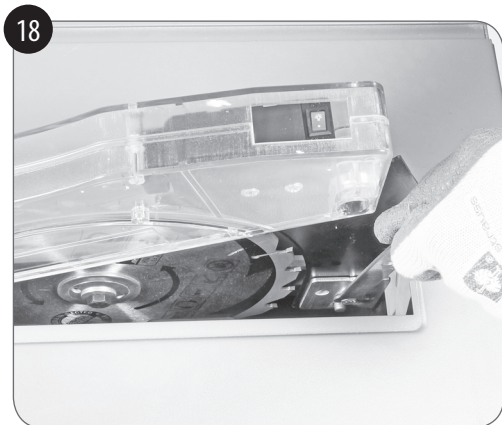
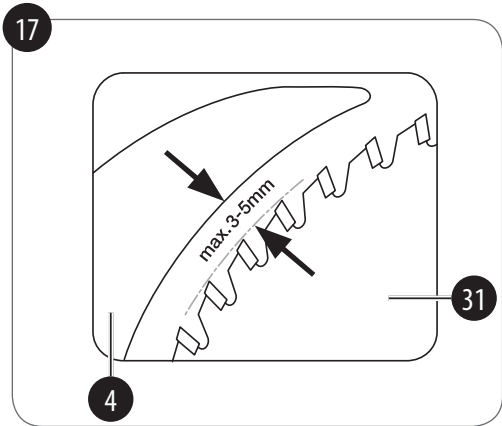
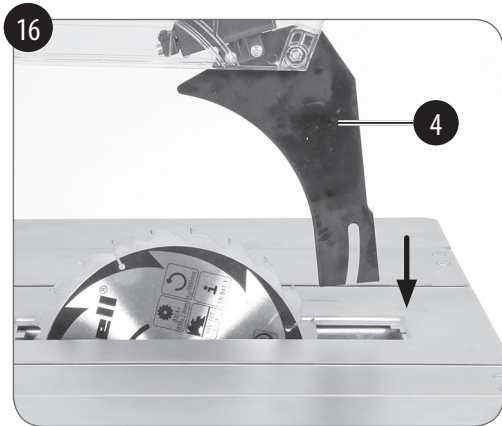

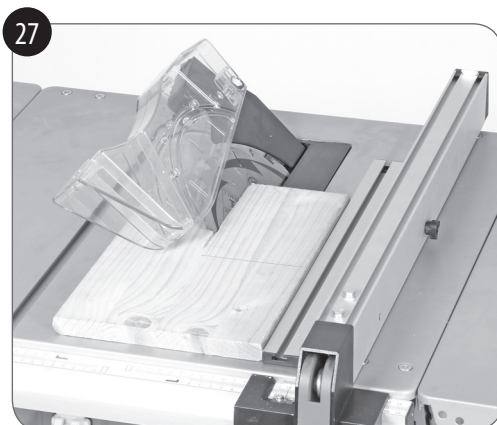
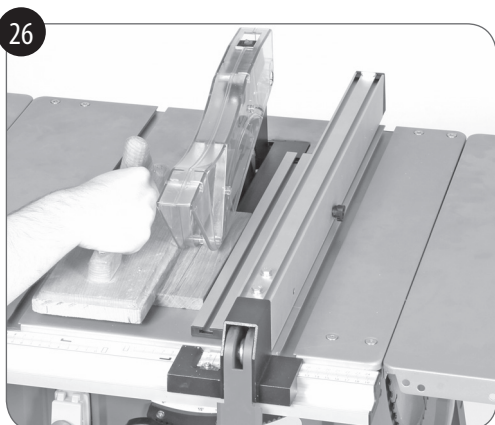
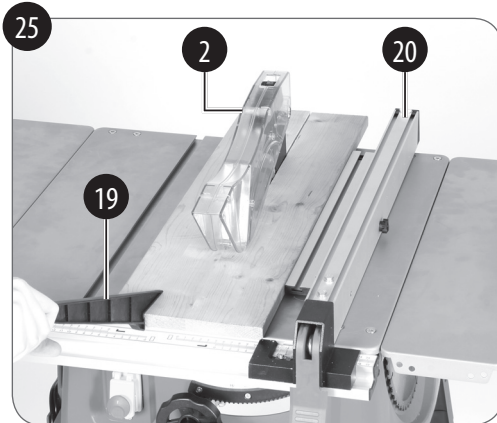
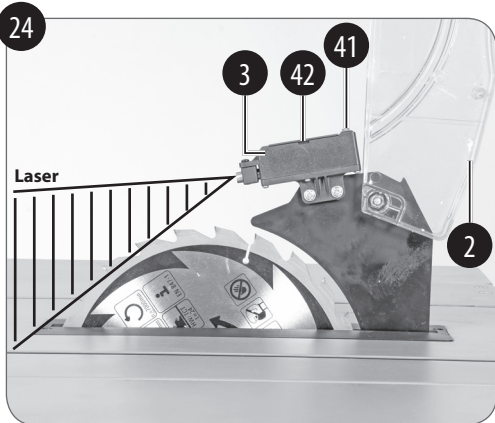
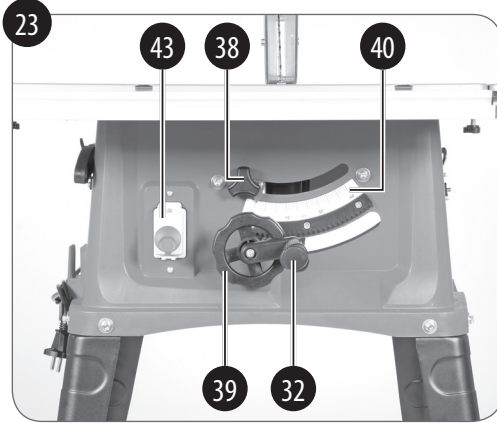

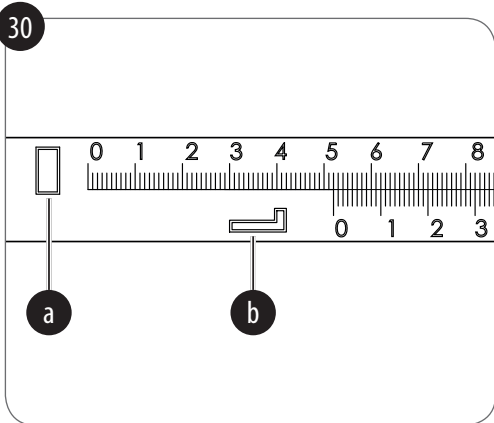
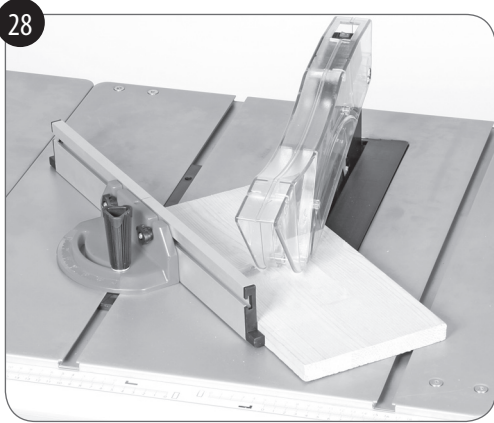

Table of contents

1. Safety information	10
2. Layout and items supplied	22
3. Intended use	23
4. Technical data	24
5. Before using the equipment	26
6. Operation	28
7. Replacing the power cable	36
8. Cleaning, maintenance and ordering spare parts	36
9. Disposal and recycling	38
10. Storage	38
11. Transport	38
12. Troubleshooting	39



Declaration of conformity: Products bearing this symbol comply with all applicable Community legislation of the European Economic Area.



Danger! - Read the operating instructions to reduce the risk of injury



Caution! Wear ear-muffs. The impact of noise can cause damage to hearing.



Caution! Wear a breathing mask. Dust which is injurious to health can be generated when working on wood and other materials. Never use the tool to work on any materials containing asbestos!



Caution! Wear safety goggles. Sparks generated during work or splinters, chips and dust emitted by the equipment can cause loss of sight.



Caution! Wear gloves. You must wear gloves at all times when handling saw blades.



Caution! Risk of injury! Do not reach into the running saw blade.



Caution! Risk of injury from sharp edges!

Danger:

When using the equipment, a number of safety precautions must be observed to avoid injuries and damage. Please read these original operating instructions and safety information with due care. Keep these operating instructions in a safe place so that the information is available at all times. If you give the equipment to any other person, please hand over these original operating instructions and the safety information as well. We cannot accept any liability for damage or accidents which arise due to a failure to follow these instructions and the safety instructions.

The up-to-date operating instructions can also be downloaded as a PDF file from our website at www.isc-gmbh.info.

1. Safety information**Danger:**

Read all the safety information and instructions. Failure to adhere to the safety information and instructions set out below may result in electric shock, fire and/or serious injury.

Keep all the safety information and instructions in a safe place for future use.

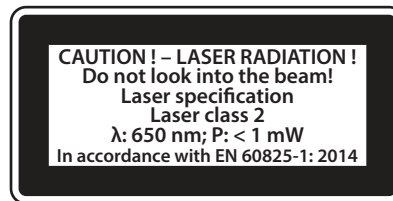
Special information about the laser**⚠ Danger! Laser radiation****Do not look into the beam****Laser class 2**

- Do not look directly into the laser beam with the naked eye.
- Never look directly into the laser path.
- Never direct the laser beam at reflecting surfaces or persons or animals. Even a low output laser beam can inflict injury on the eye.
- Caution: It is vital to follow the work procedures described in these instructions. Using the equipment in any other way may result in hazardous exposure to laser radiation.
- Never open the laser module.

Safety information on the batteries

Use of the batteries

- Inserting the batteries when the laser is switched on can cause accidents.
- If the equipment is not used correctly, the batteries may leak. Avoid contact with the battery fluid. If you come into contact with battery fluid, clean the affected body part with running water. If you get battery fluid in your eyes, seek immediate medical assistance.
- Escaped battery fluid can cause skin irritation and acid burns.
- Never expose the batteries to excess heat such as sunshine, fire or similar.
- Never recharge batteries that are not suitable for recharging. There is a risk of explosion!
- Keep batteries away from children, do not short circuit batteries or disassemble.
- Seek a doctor's advice immediately if a battery is swallowed.
- If necessary, clean the contacts on the battery and equipment before inserting the batteries.
- Ensure that you insert the batteries the right way round.
- Remove flat batteries immediately from the equipment. There is an increased risk of leakage.

- Always change all batteries in one go.
- Insert only batteries of the same type, do not use different types of batteries or used and new batteries together.
- Make sure that the equipment is switched off after use.
- Remove the batteries if the equipment is not used over a longer period.
- Do not deform/damage batteries or open them/take them apart and do not short-circuit them.

General safety information for power tools

Warning!

Read all the safety information, instructions, illustrations and technical data provided on or with this power tool.

Failure to adhere to the following instructions may result in electric shock, fire and/or serious injury.

Keep all the safety information and instructions in a safe place for future use.

The term „power tool“ used in the safety information and instructions refers to power tools operated from the mains power supply (with a power cable) and to battery operated power tools (without a power cable).

1. Workplace safety

- a) **Keep your work area clean and well lit.** Untidy or unlit work areas can result in accidents.
- b) **Do not use this power tool in an area where there is a risk of explosion and where there are inflammable liquids, gases or dust.** Power tools generate sparks that can ignite dust or vapors.
- c) **Keep children and other people away from the power tool while you are using it.** If you are distracted you may lose control of the power tool.

2. Electrical safety

- a) **The plug on the power tool must fit into the socket. The socket must not be modified in any way. Do not use adapter plugs together with power tools with a protective earth.** Unmodified plugs and matching sockets will reduce the risk of an electric shock.
- b) **Avoid body contact with earthed surfaces such as pipes, heating systems, stoves and refrigerators.** There is an increased risk of suffering an electric shock if your body is earthed.
- c) **Keep the power tool out of the rain and away from moisture.** The ingress of water into an electric power tool increases the risk of an electric shock.

- d) **Do not use the power cable for a purpose for which it is not designed, for example to carry the power tool, hang it up or to pull the plug out of the socket. Keep the power cable away from heat, oil, sharp edges and moving parts.** Power cables that are damaged or tangled increase the risk of an electric shock.
- e) **If you use an electric power tool outdoors, use only extension cables that are suitable for outdoor use.** The use of an extension cable which is suitable for outdoor use reduces the risk of an electric shock.
- f) **If you cannot avoid using the power tool in a damp location, use a residual current device (RCD) circuit breaker.** The use of a residual current device (RCD) circuit breaker will reduce the risk of suffering an electric shock.

3. Safety of persons

- a) **Be careful, watch what you are doing and be sensible and responsible when using an electric power tool. Never use the power tool if you are tired or under the influence of drugs, alcohol or medication.** One moment of inattention when using the electric tool can result in serious injuries.

- b) **Wear personal safety equipment and always wear safety goggles.** Wearing personal safety equipment such as dust masks, non-slip safety shoes, a helmet or ear muffs, depending on the type and application of the tool, reduces the risk of injury.
 - c) **Make sure that the tool cannot start up accidentally. Ensure that the power tool is switched off before you connect it to the power supply and/or connect the battery pack, pick it up or carry it.** If you have your finger on the switch while carrying the power tool or if you connect the power tool to the power supply while it is switched on, this may cause accidents.
 - d) **Remove all adjusting tools or wrenches before you switch on the power tool.** Any tool or wrench in a rotating part of the power tool could cause injuries.
 - e) **Avoid abnormal working postures. Make sure you stand squarely and keep your balance at all times.** This will enable you to control the power tool better in unexpected situations.
 - f) **Wear suitable clothes. Never wear loose fitting clothes or jewelry. Keep hair and clothing away from moving parts.** Loose clothing, jewelry or long hair can be caught by moving parts.
 - g) **If dust extraction devices and dust collection devices can be fitted, they must be connected and must be used correctly.** The use of a dust extractor can reduce the dangers posed by dust.
 - h) **Do not allow yourself to be lulled into a false sense of security and do not ignore the safety regulations covering electric power tools, even if you are familiar with the power tool after having used it many times.** Carelessness can lead to serious injuries in just a fraction of a second.
4. **Using and handling the power tool**
- a) **Do not overload your power tool. Use the correct electric tool for the job in hand.** The correct tool will enable you to work better and more safely within the specific performance range.
 - b) **Do not use an electric power tool if the switch is defective.** An electric power tool that cannot be switched on or off is dangerous and must be repaired.
 - c) **Pull the plug out of the socket and/or remove the removable battery pack before making any adjustments to the tool, changing plug-in tool parts or putting the power tool down.** The-

se precautions will prevent the power tool starting accidentally.

- d) **Keep unused electric tools out of the reach of children. Do not allow people who are not familiar with the power tool or who have not read these instructions to use the power tool.** Electric tools are dangerous if they are used by inexperienced people.
- e) **Look after power tools and plug-in tools with care. Check that moving parts function correctly and do not jam, and whether any parts are broken or damaged such that they adversely affect the function of the power tool. Have damaged parts repaired before you use the power tool.** Many accidents are caused by poorly maintained electric tools.
- f) **Keep cutting tools sharp and clean.** Carefully maintained cutting tools with sharp cutting edges will jam less and are easier to control.
- g) **Use the power tool, plug-in tools, etc. as set out in these instructions. Take account of the conditions in your work area and the job in hand.** Using electric tools for purposes other than the one for which they are designed can result in dangerous situations.

- h) **Keep the handles and grip surfaces dry, clean and free from oil and grease.** If the handles and grip surfaces are slippery, it will not be possible to operate and control the power tool safely in unforeseen situations.

5. Service

- a) **Have your power tool repaired only by trained personnel using only genuine spare parts.** This will ensure that your power tool remains safe to use.

Special safety information for bench-type circular saws

Safety information relating to the safety guards

- a) **Leave the safety guards fitted in place. Safety guards must always be in proper working order and fitted correctly.** Loose, damaged or defective safety guards must be repaired or replaced.
- b) **Always use the saw blade safety guard and the splitter when performing separation cuts.** For separation cuts in which the saw blade cuts right through the workpieces thickness, the safety guard and other safety equipment reduce the risk of injuries.

- c) **Do not use this saw to cut rebates or grooves.** For design reasons, the saw is not suitable for such work. The splitter must never be removed, because it prevents jamming and kickbacks.
- d) **Before switching on the power tool, make sure that the saw blade does not touch the safety guard, splitter or workpiece.** Accidental contact between these components and the saw blade could lead to dangerous situations.
- e) **Adjust the splitter in accordance with the description in these operating instructions.** Incorrect clearances, position or alignment may be the reason why the splitter fails to prevent a kickback effectively.
- f) **Use the right saw blade for the splitter.** For the splitter to work properly, the saw blade diameter must match the splitter, the saw plate of the saw blade must be thinner than the splitter and the tooth pitch must be greater than the thickness of the splitter.

Safety information for sawing

- a) **DANGER: Do not let your hands and fingers come anywhere near the saw blade or the sawing area.** It just takes one moment of inattention or a slip and

your hand could be directed towards them, which could result in serious injuries.

- b) **Only feed the workpiece to the saw blade or cutting tool against the direction of rotation.** If the workpiece is fed in in the same direction as the direction of rotation of the saw blade above the table, this could lead to both the workpiece and your hand being drawn in to the saw blade.
- c) **Never use the miter stop to feed in the workpiece when performing longitudinal cuts, and never use the parallel stop in addition for setting the length when performing cross cuts with the miter stop.** Feeding the workpiece in with both the parallel stop and the miter stop at the same time increases the likelihood of the saw blade getting jammed, which will result in kickback.
- d) **When performing longitudinal cuts, always apply the infeed force on the workpiece between the stop rail and the saw blade. Use a push stick if the gap between the stop rail and the saw blade is less than 150 mm, and a push block if the gap is less than 50 mm.** Work aids of this kind help ensure that your hand is kept at a safe distance

from the saw blade.

- e) **Only use the supplied push stick of the manufacturer or one which has been manufactured in accordance with instructions.** The push stick ensures that your hand is kept at a sufficient distance from the saw blade.
 - f) **Never use a damaged or partially sawn push stick.** If the push stick is damaged, it could break, causing your hand to come into contact with the saw blade.
 - g) **Do not perform your work “free-handed”. Always use the parallel stop or the miter stop to position and feed in the workpiece.** “Free-handed” means using your hand to support or feed in the workpiece with the parallel stop or miter stop. Free-handed sawing leads to misalignment, jamming and kickbacks.
 - h) **Never reach over or into a rotating saw blade.** Reaching for a workpiece could lead to accidental contact with the rotating saw blade.
 - i) **Provide support for long and/or wide workpieces behind and/or at the side of the saw table, so that they stay horizontal.** Long and/or wide workpieces have a tendency to fall off at the edge of the saw table; this leads to a
- loss of control, the jamming of the saw blade and kickbacks.
 - j) **Feed the workpiece in smoothly. Do not bend or twist the workpiece. If the saw blade becomes jammed, switch off the power tool immediately, pull out the power plug and rectify the cause of the jam.** If the saw blade becomes jammed because of the workpiece, this could cause a kickback or cause the motor to block.
 - k) **Do not remove the sawn material while the saw is running.** Sawn material could become stuck between the saw blade and the stop rail or in the saw blade and cause your fingers to be drawn into the saw blade if you attempt to remove it. Switch off the saw and wait until the saw blade has come to a standstill before removing the material.
 - l) **For longitudinal cuts on workpieces thinner than 2 mm, use an additional parallel stop which has contact with the table surface.** Thin workpieces can get wedged under the parallel stop and cause kickback.

Causes of kickbacks and related safety information

A kickback is the sudden reaction of the workpiece resulting from a caught, jammed saw blade or a cut performed at an angle in the workpiece relative to the saw blade, or when part of the workpiece becomes jammed between the saw blade and the parallel stop or any other fixed object. In most cases when kickback occurs, the workpiece gets caught by the rear section of the saw blade, gets lifted from the saw table and thrown in the direction of the operator. Kickback is the result of the bench-type circular saw being used incorrectly or wrongly. It can be prevented by suitable precautions, as described below.

- a) **Never position yourself in a direct line with the saw blade. Always stand to the side of the saw blade, at the side with the stop rail.** In the event of kickback, the workpiece can be thrown at high speed towards persons who are standing in line with the saw blade.
- b) **Never reach into or behind the saw blade to pull or support the workpiece.** This could lead to accidental contact with the saw blade, or kickback could cause your fingers to be drawn into the saw blade.
- c) **Never hold and press a workpiece against the rotating saw blade when you want to saw the workpiece.** Pressing the workpiece against the saw blade when sawing workpiece will result in jamming and kickback.
- d) **Align the stop rail parallel to the saw blade.** If the stop rail is not properly aligned, the workpiece will press against the saw blade and cause kickback.
- e) **Do not use this saw to cut rebates or grooves.** For design reasons, the saw is not suitable for such work. The splitter must never be removed, because it prevents jamming and kickbacks.
- f) **Be particularly careful when sawing in areas into which you cannot see on workpieces which have been joined together.** The plunge-cutting saw blade may saw into objects which could cause kickback.
- g) **Support large panels to reduce the risk of a kickback by a jammed saw blade.** Large panels may sag under their own weight. Panels must be provided with support at all points where they project over the table surface.
- h) **Do not work on any workpieces which are twisted, knotted or war-**

ped or do not have a straight edge on which they can be guided with a miter stop or along a stop rail. A warped, knotted or twisted workpiece is instable and will lead to the misalignment of the kerf with the saw blade, and jamming and kickback.

- i) **Never saw several workpieces stacked one on top of the other or one after the other.** The saw blade could catch one or more parts and cause kickback.
- j) **Do not start the saw if the saw is in the workpiece.** If the saw blade is jammed it may lift the workpiece and cause kickback when the saw is restarted.
- k) **Keep the saw blades clean, sharp and adequately set. Never use bent saw blades or saw blades with cracked or broken teeth.** Saw blades which are sharp and properly set minimize jamming, blockages and kickback.

Safety information for the operation of bench-type circular saws

- a) **Switch off the bench-type circular saw and disconnect it from the mains power supply before you remove the table insert, change the saw blade, adjust the splitter or the saw blade safety guard and when the machine**

is left unattended. Precautions are intended to help prevent accidents.

- b) **Never leave the bench-type circular saw running unattended. Switch off the power tool and do not leave it before it has come to a complete standstill.** A saw which is left running unattended is an uncontrolled danger.
- c) **Set the saw up at a location which is level and well-lit and where you can stand steadily and keep your balance. The location where you set it must provide sufficient space for you to handle your larger workpieces easily.** Untidiness, unlit work areas and uneven, slippery floors can lead to accidents.
- d) **Remove wood sawings and sawdust regularly from under the saw table and/or from the dust extractor.** Accumulations of sawdust are combustible and can self-ignite.
- e) **Secure the bench-type circular saw.** If the bench-type circular saw is not properly secured, it could move or topple over.
- f) **Remove all adjusting tools, residual wood, etc., from the bench-type circular saw before you switch it on.** Distractions or possible jams can be dangerous.

- g) Always use saw blades of the correct size and with a suitable mounting hole (diamond-shaped or round).**

Saw blades that do not match the mounting parts of the saw will not rotate truly and will result in a loss of control.

- h) Never use damaged or the incorrect saw blade assembly material such as, e.g. flanges, washers, screws or nuts.**

This saw blade assembly material has been specially designed for your saw, for safe operation and optimum performance.

- i) Never get onto the bench-type circular saw and never use the bench-type circular saw as a step stool.** Serious injuries could occur if the power tool topples over or if you come into contact with the saw blade accidentally.

- j) Make sure that the saw blade is fitted in the correct direction of rotation. Do not grinding wheels or wire brushes with the bench-type circular saw.** If the saw blade is fitted incorrectly or accessories are used which are not recommended, this could lead to serious injuries.

Additional safety instructions

1. Only use a saw blade which has the external diameter and hole diameter specified in the original operating instructions ("Technical data" section).
2. Only use saw blades whose permissible maximum speed of rotation is not lower than the maximum spindle speed of the bench-type circular saw and which are suitable for the material to be cut.
3. Only fit blades which are well sharpened and have no cracks or deformations.
4. Faulty saw blades must be replaced immediately.
5. It must be possible for the blade to run freely.
6. Check the saw blade guard for damage and wear each time before using the saw.
7. The saw blade guard must lower again automatically under its own weight after each cut. The saw blade guard must lift when the workpiece is pushed in the direction of the saw blade.
8. Damaged or faulty safety devices have to be replaced immediately.
9. It is imperative to make sure that all devices which cover the saw blade are in good working order.

10. Never dismantle the machine's safety devices or render them inoperative.
11. Refit all guards and safety devices immediately after you have completed any repairs or maintenance work.
12. Keep the push stick or handle for a push block at the machine at all times, even when you are not using them. Slot the push stick or the push block into its holder when not in use.
13. The sawing of angles/wedges is only permitted if an appropriate auxiliary stop (cross stop) is used.
14. Replace the table insert if it is worn – pull out the power plug –
15. If necessary, wear suitable personal protection equipment. This could consist of:
 - a. Ear muffs to prevent the risk of damaging your hearing;
 - b. A breathing mask to avoid the risk of inhaling hazardous dust;
 - c. Always wear gloves when handling saw blades and rough materials. Whenever practicable, saw blades must be carried in a container;
16. Use only the transport devices to move the equipment. Never use the guards for handling or moving the equipment.
17. While you are moving the machine it is best to cover the top part of the blade, e.g. with the guard.
18. Give these safety instructions to all persons who work on the machine.
19. Do not use this saw to cut fire wood.
20. Do not use this saw to cross-cut roundwood.
21. The machine is equipped with a safety switch to prevent it from being switched on again accidentally after a power failure.
22. If you need to use an extension cable, make sure its conductor cross-section is big enough for the saw's power consumption. Minimum cross-section: 1.5 mm².
23. If you use a cable reel, the complete cable must be pulled off the reel.
24. Never load the machine so much that it cuts out.
25. Always press the workpiece firmly against the saw table.
26. Make sure that off-cuts do not catch on the saw blade crown. Risk of catapulting!
27. Be sure to observe the safety information and operating and maintenance instructions issued by the manufacturer, as well as the dimensions listed in the Technical Data.
28. It is imperative to observe the accident prevention regulations in force in your

area as well as all other generally recognized rules of safety.

29. Note the information published by your professional associations.
30. Operators must be at least 18 years of age.
31. Never remove loose splinters, chips or jammed pieces of wood when the saw blade is running.
32. To rectify faults or remove jammed pieces of wood, always switch off the machine first. – Pull out the power plug –
33. Persons working on the machine should not be distracted.
34. Keep your workplace clean of wood scrap and any unnecessary objects.
35. Before you use the machine for the first time, check that the voltage marked on the rating plate is the same as your supply voltage.
36. Check the power cable. Never use a faulty or damaged power cable.
37. Operate the saw only with a suitable vacuum extraction system or a standard industrial vacuum cleaner.
38. Keep unused electric tools out of the reach of children. Do not allow people who are not familiar with the tool or who have not read these instructions to use the tool. Electric tools are dangerous if they are used by inexperienced people.
39. Keep your cutting tools sharp and clean. Carefully maintained cutting tools with sharp cutting edges will jam less and are easier to control.
40. Have your tool repaired only by trained personnel using only genuine spare parts. This will ensure that your tool remains safe to use.
41. All covers and safety devices have to be properly fitted before the equipment is switched on.
42. When working with wood that has been processed before, watch out for foreign bodies such as nails or screws etc.
43. Before you actuate the On/Off switch, make sure that the saw blade is correctly fitted and that the equipment's moving parts run smoothly.
44. Keep handles dry, clean and free from oil and grease.

Keep this safety information in a safe place!

2. Layout and items supplied

2.1 Layout (Fig. 1-29)

1. Saw table
2. Sawblade guard
3. Laser
4. Splitter
5. Table insert
6. Guide groove (saw table)
7. Bench width extension
8. Leg (4x)
9. Middle strut (4x)
10. Tilt guard (2x)
11. Rubber foot (4x)
12. Size 10 wrench / saw blade
13. Size 10 wrench / wrench
14. Ring spanner
15. Cross stop (with lock bolt and knurled nut (2x))
16. Knurled screw (cross stop)
17. Stop rail (cross stop)
18. Guide rail system (cross stop)
19. Push stick
20. Parallel stop (with lock bolt and knurled nut (2x))
21. Window (parallel stop)
22. Stop rail (parallel stop)
23. Lock bolt (8x)
24. Hexagon screw, size M6 x 12 mm (4x)
25. Hexagon screw, size M6 x 16 mm (8x)
26. Spring washer (24x)

27. Washer, small (16x)
28. Washer, large (8x)
29. Hex nut (12x)
30. Knurled screw (table width extension)
31. Blade
32. Crank arm
33. Clamping screw
34. Clamping plate
35. Eccentric lever
36. Bar with scale (saw table)
37. Dust extraction connector
38. Locking screw
39. Crank wheel
40. Angle scale
41. Laser switch
42. Battery compartment cover
43. Operating switch (Green: I / Red: 0)
44. Hexagon screw (saw blade)

2.2 Items supplied

- Open the packaging and take out the equipment with care.
- Remove the packaging material and any packaging and/or transportation braces (if present).
- Check to see if all the items are supplied.
- Inspect the equipment and accessories for transport damage.
- If possible, keep the packaging until the end of the guarantee period.

- Check that the equipment after unpacking to ensure that it is complete and check it for damage which may have occurred in transit – to prevent hazards. If you have any doubts, do not use it but contact our customer service instead. You will find the service address in our warranty terms on the warranty card.

Important!

The equipment and packaging material are not toys. Do not let children play with plastic bags, foils or small parts. There is a risk of choking and suffocating!

- Bench-type circular saw
- Bench width extension
- Laser
- Carbide-tipped saw blade
1x 48 teeth / 1x 24 teeth
- Splitter
- Saw blade guard
- Bag with installation materials
- Parallel stop
- Cross stop
- Push stick
- Original operating instructions

3. Intended use

The bench-type circular saw is designed for the slitting and cross-cutting (only with the cross stop) of all types of timber commensurate with the machine's size. The equipment is not to be used for cutting any type of round wood.

The equipment is to be operated only with suitable saw blades (saw blades made of HM or CV) It is prohibited to use any type of HSS saw blade and cutting-off wheel. To use the equipment properly you must also observe the safety information, the assembly instructions and the operating instructions to be found in these operating instructions. All persons who use and service the equipment have to be acquainted with these operating instructions and must be informed about the equipment's potential hazards. It is also imperative to observe the accident prevention regulations in force in your area. The same applies for the general rules of health and safety at work. The manufacturer will not be liable for any changes made to the equipment nor for any damage resulting from such changes.

Even when the equipment is used as prescribed it is still impossible to eliminate certain

residual risk factors. The following hazards may arise in connection with the equipment's construction and design:

- Contact with the saw blade in the uncovered saw zone.
- Reaching into the running saw blade (cut injuries).
- Kick-back of workpieces and parts of workpieces.
- Saw blade fracturing.
- Catapulting of faulty carbide tips from the saw blade.
- Damage to hearing if essential ear-muffs are not used.
- Risk of eye damage if essential safety goggles are not worn.
- Risk of harm to health if the requisite breathing mask is not used.
- Harmful emissions of wood dust when used in closed rooms.

The equipment may be used only for its intended purpose. Any other use is deemed to be a case of misuse. The user/operator and not the manufacturer will be liable for any damage or injuries of any kind resulting from such misuse.

Please note that our equipment has not been designed for use in commercial, trade or industrial applications. Our warranty will

be voided if the equipment is used in commercial, trade or industrial businesses or for equivalent purposes.

4. Technical data

Supply voltage: 220-240 V~/50 Hz
 Power: 1800 W
 Idle speed n_0 : 4250 rpm
 Carbide saw blade
 with 24 teeth: \emptyset 254 x \emptyset 30 x 2.8 mm
 Carbide saw blade
 with 48 teeth: \emptyset 254 x \emptyset 30 x 2.8 mm
 Max. cutting depth: 80 mm / 90°
 55 mm / 45°
 Height adjustment: infinite 0-80 mm
 Tilting saw blade: infinite 0°-45°
 Dust extraction connector: \emptyset 35 mm
 Net weight: approx. 24 kg

Dimensions of the bench-type circular saw

Working height: 870 mm
 Table size: 580 x 555 mm
 Table width extension: 580 x 150 mm

Laser

Laser class:2
 Battery: 2 x 1.5V  AAA/LR03

Noise emission values

The noise emission values were measured in accordance with EN 62841-3-1.

Sound pressure level L_{pA} 91.1 dB(A)

Uncertainty K_{pA} 3 dB

Sound power level L_{WA} 105.3 dB(A)

Uncertainty K_{WA} 3 dB

Wear ear-muffs.

The impact of noise can cause damage to hearing.

The stated noise emission values were measured in accordance with a set of standardized criteria (EN 62841-1/-3-1) and can be used to compare one power tool with another.

The stated noise emission values can also be used to make an initial assessment of exposure.

WARNING!

The noise emission levels may vary from the level specified during actual use, depending on the way in which the power tool is used, especially the type of workpiece it is used for.

For the protection of the operator, safety measures must be specified which are based on an estimate of the stress during the actual conditions of use (all stages of the operating cycle must be considered, e.g. times in which the electric tools are switched off and times in which the tool is switched on but operates without load).

Reduce noise generation and vibration to a minimum!

- Use only equipment that is in perfect condition.
- Maintain and clean the equipment regularly.
- Adapt your way of working to the equipment.
- Do not overload the equipment.
- Have the equipment checked if necessary.
- Switch off the equipment when not in use.
- Wear gloves.

5. Before using the equipment

Before you connect the equipment to the power supply make sure that the data on the rating plate are identical to the supply voltage.

Warning!

Always pull out the power plug before making adjustments to the equipment.

Assembly

WARNING! Risk of injury!

If you assemble the bench-type circular saw incorrectly, this could lead to serious injuries.

Assemble the bench-type circular saw correctly and completely, including all covers and safety devices, before using for the first time.

- Never under any circumstances insert the power plug into the socket outlet before completion of assembly.

Fitting the legs. (Fig. 5-11)

1. Turn the saw table (1) over and set it down on the floor.
2. Fit the four legs (8) loosely to the saw table with the help of two hexagon screws (25) and two large washers (28) for each leg.

3. To do so, use the drill holes provided in the saw table and the threaded sockets in the legs.
4. Then fit one middle strut (9) between each of the legs by inserting the fastening opening at the ends of the middle strut into the detents on the legs and pressing them so that they lock into place.
5. Secure the middle struts to the legs using two lock bolts (23), two small washers (27), two spring washers (24) and two hex nuts (29) on each.
6. Now tighten all the screw connections.
7. Then plug one rubber foot (11) onto each leg (8).
8. Then fit one tilt guard (10) to each of the rear legs using two hexagon screws (24), spring washers (26), small washers (27) and hex nuts (29) each.

Fitting the table width extension (Fig. 12)

1. To be able to fit the table width extension (7), remove the screw (A) on both undersides of the guide tubes.
2. After undoing the two knurled screws (30), you can slide the table width extension into the opening.
3. Now fit the screw (A) back in the guide tube. This serves as an end stop.

4. You can use the knurled screw (30) to adjust the width of the table width extension on an infinitely adjustable basis as far as the end stop.
5. Carefully turn the saw table over and set it down with its legs on the floor.

Fitting/adjusting the splitter (Fig. 14-19)

WARNING! Risk of injury!

If the bench-type circular saw is started up by accident or the saw blade is handled incorrectly, there is a risk of serious injuries.

- Always pull the power plug from the socket outlet before making adjustments to the bench-type circular saw.
- Always wear protective gloves when handling the saw blade or working in its immediate vicinity. Check the splitter (4) every time after you have changed the saw blade and align it correctly if necessary.

1. Make sure that the saw blade (30) is lowered to the maximum in the saw table (1). To lower the saw blade if necessary, turn the crank (32) counterclockwise as far as the stop.
2. Remove the two fastening screws and remove the table insert (5) from the saw table. When you do so, always check the table insert: Replace the table

insert immediately if it is damaged or is no longer flush with the saw table.

3. Make sure that the angle adjustment facility of the saw blade is set to 0°. If necessary, adjust the angle adjustment facility as described in the section "Setting the cutting angle".
4. To turn the saw blade out of the saw table as far as the maximum, turn the crank clockwise as far as the stop.
5. Undo the clamping screw (33) using a size 10 wrench (12) by turning it several revolutions counterclockwise.
6. Insert the splitter behind the clamping plate (34) and push it down to the maximum.
7. Turn the clamping screw several revolutions clockwise to screw it tight.
8. Align the splitter so that there is a gap of 3-5 mm to the saw blade at all points.
9. Secure the splitter by turning the clamping screw clockwise again to tighten it.
10. To turn the saw blade into the saw table as far as the maximum, turn the crank counterclockwise as far as the stop.
11. Pull the table insert slightly apart and push it over the laser and splitter again. Insert the lug on the rear end of the table insert into the corresponding groove on the saw table and then lower the

front end.

12. Check that the table insert is secure: The table insert must be flush with the saw table.
13. Secure the table insert using the two fastening screws.

Fitting the parallel stop (Fig. 21)

1. Slide the stop rail (22) onto the parallel stop (20) so that the square necks of the two lock bolts slide into the profile of the stop rail.
2. Secure the stop rail on the parallel stop by tightening the two knurled nuts.
3. Place the parallel stop with open eccentric lever (35) on the rail (36) on the saw table.
4. To change to position of the parallel stop, move the parallel stop with open eccentric lever to the right or left.
5. Press the eccentric lever completely down to secure the parallel stop in the desired position.

Connecting a vacuum extraction device (Fig. 22)

- The dust extraction connector (37) is located on the back of the bench-type circular saw.
- Connect the suction hose of a suitable chip extraction system (e.g. a multi-

purpose vacuum cleaner) to the dust extraction connector (37) and secure it with, e.g. a hose clip. Please note: A normal household vacuum cleaner is not suitable to be used as a vacuum extraction device in this case.

6. Operation

Setting the cutting depth

Use the crank (32) to turn the saw blade (31) out of the saw table (1) and lower it into the saw table. Adjust it to the depth you require as follows:

- **Increasing the cutting depth:**
Turn the crank clockwise so that the saw blade is moved out of the saw table.
- **Reducing the cutting depth:**
Turn the crank counterclockwise so that the saw blade is lowered into the saw table.

Setting the cutting angle (Fig. 23)

1. Turn the locking screw (38) approx. one revolution counterclockwise to slacken it.
2. Use the crank wheel (39) to adjust the cutting angle to the angle you require on the angle scale (40).
3. Turn the locking screw clockwise to tighten it and secure the saw blade (31)

at the desired angle.

Parallel stop

Stop height

The stop rail (22) for fitting on the parallel stop (20) has two different guide faces (high and low). For thick material you must use the stop rail stood on edge (with a workpiece thickness of over 25 mm), for thin material (with a workpiece thickness of less than 25 mm) you must use the stop rail lying flat.

To turn the stop rail, proceed as follows:

1. Slacken the knurled nuts on the parallel stop by turning them several revolutions.
2. Pull the stop rail off the parallel stop.
3. Turn the stop rail into the required position.
4. Slide the stop rail onto the parallel stop so that the square necks of the two lock bolts slide into the profile of the stop rail.
5. Turn the knurled nuts to tighten them again to secure the stop rail to the parallel stop.

Cutting width

The parallel stop (20) has to be used when making longitudinal cuts in wooden workpieces, and it should be mounted on the

right-hand side of the saw blade as far as possible.

There are two different scales on the rail (36) on the front side of the saw table, and these indicate the distance between the stop rail and saw blade, in other words the cutting width:

- Use scale "a" when you use the parallel stop (20) for thick material without the stop rail (22).
- Use scale "b" when you use the parallel stop (20) for thin material with the stop rail (22) fitted.

To set the parallel stop to a specific dimension, proceed as follows:

1. Raise the eccentric lever (35).
2. Move the parallel stop until the desired dimension can be seen on the scale in the window (21).
3. Press the eccentric lever completely down to secure.
4. Check the set dimension, e.g. with the use of a folding rule on the saw blade and at the rear end of the table, to ensure that the stop is really parallel.

Setting the stop length

The stop rail (22) can be moved in longitudinal direction in order to prevent the workpiece from becoming jammed.

Rule of thumb: The rear end of the stop comes up against an imaginary line that begins roughly at the center of the blade and runs at an angle of 45° to the rear.

1. Set the required cutting width.
2. Slacken the knurled nuts on the parallel stop (20) by turning them several revolutions.
3. Move the stop rail until the rear end of the stop rail touches the imaginary 45° line.
4. Tighten the knurled nuts again.

Cross stop

Do not push the stop rail of the cross stop too far toward the saw blade. The distance between the stop rail and the blade should be approx. 2 cm.

1. Slide the stop rail (17) onto the cross stop (15) so that the square necks of the two lock bolts slide into the profile of the stop rail.
2. Secure the stop rail on the cross stop by tightening the two knurled nuts.
3. Slide the guide rail system (18) of the cross stop into the guide grooves (6) of the saw table.
4. Slacken the knurled screw (16) and turn the cross stop until the line on the guide rail system coincides with the required angular setting.

5. Tighten the knurled screw again.

Laser (Fig. 24)

With the help of the laser (3), you can perform precision cutting work with your bench-type circular saw. The laser light is generated by a laser diode. The laser light is enlarged to form a line and is emitted through the laser emission aperture. You can then use the line as an optical marker of the sawing line for precision cuts. It is important that you obey the safety instructions for the laser.

Switching on the laser:

Set the laser switch (41) to "ON".

When the saw blade guard is fitted, the laser switch can be accessed through the opening on the top. A red laser beam will now be projected from the laser emission aperture. If you guide the laser beam along the sawing line mark as you saw, you will produce clean, precise cuts.

Switching off the laser:

Set the laser switch (41) to "OFF".

The laser beam will go out.

Always switch off the laser when not in use in order to save the batteries.

The laser beam can be blocked by deposits of dust and chips. You should therefore

remove these particles from the saw blade guard each time after use.

Inserting/changing the laser batteries (Fig. 11)

The laser beam shows you exactly where the saw blade (31) will be cutting next and therefore enables you to achieve extremely precise cuts. For the operation of the laser (3) you require two type 1.5 V  AAA/LR03 batteries (supplied with the product), which are inserted/changed as follows:

1. Set the laser switch (41) to position 0 (laser off).
2. Swing the saw blade guard (2) up as shown in Fig. 24.
3. Flip the battery compartment cover (42) up and remove it.
4. Remove the old batteries from the battery compartment if necessary. Please observe the instructions in the section "Disposal".
5. Insert the new batteries, ensuring that you fit them the right way round according to the polarity shown in the battery compartment.
6. Replace the battery compartment cover.
7. Swing the saw blade guard (2) down again.

Switching the bench-type circular saw on and off

WARNING! Risk of injury!

If the bench-type circular saw has been assembled incorrectly, this could lead to serious injuries.

- Assemble the bench-type circular saw correctly and completely before using for the first time.
- Before you switch on the bench-type circular saw, make sure that the saw blade is correctly fitted and that the equipment's moving parts run smoothly.
- Press the green operating switch I (43) to switch on.
The motor starts. Wait for the saw blade (31) to reach its maximum speed of rotation before starting sawing.
- To switch off the bench-type circular saw, press the red operating switch 0 (43).

Caution: The saw blade continues to run for quite a while. Do not leave the bench-type circular saw until the saw blade has come to complete standstill.

Sawing

WARNING! Risk of injury!

There is a risk of serious injuries if the bench-type circular saw is handled improperly.

- Do not position yourself head-on in front of the bench-type circular saw when performing longitudinal cuts, but position yourself at an angle to the course of the cut.
 - Always use the parallel stop when making angular cuts.
 - Use a push stick or push block to feed the workpiece past the saw blade. If the push stick is damaged or worn, replace it immediately.
 - Secure long workpieces against falling off at the end of the cut. To do so, use e.g. standard roller stands, etc.
 - After every new adjustment, make a trial cut in order to check the set dimensions.
 - After switching on the bench-type circular saw, wait for the blade to reach its maximum speed of rotation before commencing with the cut.
 - Take extra care when starting the cut!
 - Only use the bench-type circular saw together with a vacuum extraction device.
- Regularly check and clean the suction channels.

Making longitudinal cuts

When you make a longitudinal cut, you cut the workpiece in its longitudinal direction. To do so, press one edge of the workpiece against the parallel stop (20) while the flat side lies on the saw table (1).

1. Set the parallel stop in accordance with the workpiece height and the desired width (see the section "Parallel stop").
2. Lower the saw blade guard (2) down to the saw table. When sawing, the saw blade guard will be pressed up by the workpiece.
3. Switch on an extraction system and then the bench-type circular saw.
4. Place your hands (with fingers closed) flat on the workpiece and push the workpiece along the parallel stop and into the saw blade (31).
5. Provide guidance at the side with your left or right hand (depending on the position of the parallel stop) only as far as the front edge of the saw blade guard.
6. Always push the workpiece through to the end of the splitter (4).
7. Switch off the bench-type circular saw and the vacuum extraction system.

8. Leave the off-cut piece on the saw table until the saw blade is back in its position of rest.

Cutting narrow workpieces (Fig. 25)

Be sure to use a push stick (19) when making longitudinal cuts in workpieces smaller than 120 mm in width. The push stick is supplied with the saw. Replace a worn or damaged push stick immediately.

Cutting very narrow workpieces (Fig. 26)

- Be sure to use a push block when making longitudinal cuts in very narrow workpieces with a width of 30 mm and less.
- The low guide face of the parallel stop is best used in this case.

There is no push block supplied with the saw! (Available from your specialist dealer) Replace the push block without delay when it becomes worn.

Making angular cuts (Fig. 27)

1. Set the saw blade (31) to the desired angle (see the section "Setting the cutting angle").
2. Set the parallel stop (20) in accordance with the workpiece width and height (see the section "Parallel stop").

3. Carry out the cut in accordance with the workpiece width (see the section "Making longitudinal cuts").

Making cross cuts (Fig. 28)

WARNING! Risk of injury!

There is a risk of serious injuries if the bench-type circular saw is handled improperly.

- Always hold the guided part of the workpiece. Never hold the part which is to be cut off.
 - Always push the cross stop forward until the workpiece is cut all the way through.
1. Adjust the cross stop (15) to the desired position (see the section "Cross stop"). If you also want to tilt the saw blade (31), slide the cross stop into the right guide groove (6) to prevent your hand and the cross stop from making contact with the saw blade guard (2).
 2. Lower the saw blade guard down to the saw table (1). When sawing, the saw blade guard will be pressed up by the workpiece.
 3. Press the workpiece firmly against the cross stop.
 4. Switch on an extraction system and then the bench-type circular saw.

5. Push the cross stop and the workpiece toward the blade in order to make the cut.
6. Switch off the bench-type circular saw and the vacuum extraction system.
7. Leave the off-cut piece on the saw table until the saw blade is back in its position of rest.

Cutting particleboard

To prevent the cutting edges from cracking when working with particleboards, do not set the saw blade (31) more than 5 mm higher than the thickness of the workpiece.

After sawing

1. Switch off the bench-type circular saw by pressing the red operating switch 0 (43).
2. Wait until the saw blade (31) has reached a complete standstill and then take the workpiece off the saw table (1).
3. Disconnect the bench-type circular saw from the mains power supply by pulling the power plug out of the socket.
4. Allow the bench-type circular saw to cool down completely.

Removing jammed material

WARNING! Risk of injury!

There is a risk of serious injuries if the bench-type circular saw is handled improperly.

- Switch off the bench-type circular saw immediately and pull the power plug out of the socket if the saw blade has got jammed in the workpiece or if any other blockages occur.
- Wear protective gloves, do not touch the saw blade with bare hands.

Changing the saw blade (Fig. 29)

WARNING! Risk of injury!

Warning!

Always disconnect the power plug before you change the saw blade!

There is a risk of serious injuries if the bench-type circular saw is handled improperly.

- Wear protective gloves, do not touch the saw blade with bare hands.
1. Remove the two fastening screws and remove the table insert (5) from the saw table. When you do so, always check the table insert: Replace the table insert immediately if it is damaged or is no longer flush with the saw table.
 2. Make sure that the angle adjustment facility of the saw blade is set to 45°. If

necessary, adjust the angle adjustment facility as described in the section "Setting the cutting angle".

3. To turn the saw blade out of the saw table as far as the maximum, turn the crank clockwise as far as the stop.
4. Remove the splitter by turning the clamping screw (33) several revolutions counterclockwise to slacken it and then pull the splitter up and out.
5. Secure the saw blade using the saw blade wrench (12): The detents on the saw blade wrench engage in the openings in the saw blade flange.
6. Using the ring wrench (14), turn the hexagon screw (44) approx. one revolution counterclockwise to slacken it.
7. Hold the saw blade firmly and carefully in one hand and remove the hexagon screw (44) complete with washer and saw blade flange from the drive shaft.
8. Now remove the saw blade from the drive shaft and carefully pull it up and out of the saw table.
9. Clean the outer and inner saw blade flange carefully before you fit a new saw blade.
10. Place a new saw blade on the drive shaft. Check that the direction of rotation is correct: the cutting angle of the teeth must point in the running direction, meaning forwards. The running direction is normally also shown on the saw blade as well.
11. Fit the outer saw blade flange back on the drive shaft. Make sure that the outer saw blade flange is correctly aligned when you do this.
12. Insert the hexagon screw through the pressure plate and into the drive shaft and tighten it by hand.
13. Turn the saw blade carefully in the running direction: it must be exactly centered and must not "wobble". Check that the saw blade, outer flange and pressure plate are correctly seated. If the saw blade is not exactly centered, align the parts again.
14. Hold the saw blade securely using the saw blade wrench and turn the hexagon screw until it is tight using the ring wrench.
15. Fit the splitter, table insert and saw blade guard as described in the section "Fitting/adjusting the splitter".

7. Replacing the power cable

Danger!

If the power cable for this equipment is damaged, it must be replaced by the manufacturer or OEM after-sales service or by similarly trained personnel to prevent hazards.

8. Cleaning, maintenance and ordering spare parts

Hazard!

Always pull out the power plug before starting any cleaning work.

8.1 Cleaning

WARNING! Risk of injury!

There is a risk of serious injuries if the bench-type circular saw is handled improperly.

- Switch off the bench-type circular saw and pull the power plug out of the socket before you start any cleaning work.
- Wear suitable protective gloves when carrying out work on the bench-type circular saw.

WARNING! Risk of burns!

The saw blade can become hot during operation and you may burn yourself.

- Allow the saw blade to cool down completely every time before you start any cleaning work.

NOTE! Risk of damage

The ingress of water into the housing could cause a short-circuit. Improper cleaning could lead to damage to the bench-type circular saw.

- Do not wash the bench-type circular saw and do not spray it down with a water jet either.
- Ensure that no water gets into the housing.
- Never use any aggressive cleaning products, sharp or metallic cleaning implements such as knives, hard spatulas or similar. These could damage the surfaces.
- Clean the bench-type circular immediately after you use it each time.
- Keep the safety devices free of dirt and dust as far as possible.
- Wipe the bench-type circular saw with a clean cloth or blow it down with compressed air at low pressure. Wear safety goggles when using compressed air.

- In cases of stubborn dirt, use a damp cloth and a little soft soap.

8.2 Carbon brushes

In case of excessive sparking, have the carbon brushes checked by a qualified electrician.

Danger! The carbon brushes should not be replaced by anyone but a qualified electrician.

8.3 Maintenance

WARNING! Risk of injury!

There is a risk of serious injuries if the bench-type circular saw is handled improperly.

- Switch off the bench-type circular saw and pull the power plug out of the socket before you start any maintenance work.
- Wear suitable protective gloves when carrying out work on the bench-type circular saw.
- There are no parts inside this bench-type circular saw which can be repaired by the user. Never try to repair the bench-type circular saw yourself. Always contact a qualified expert.

NOTE! Risk of damage

The ingress of water into the housing could cause a short-circuit.

- Never immerse the bench-type circular saw in water.
- Ensure that no water gets into the housing.

Correct and regular care is not only important for safe use, it will also contribute to a longer service life for your bench-type circular saw.

Inspecting the bench-type circular saw

Inspect the bench-type circular saw regularly to check its condition.

Among other things, check whether:

- the switches are undamaged,
- the accessories are in perfect condition,
- the power cable and the power plug are undamaged,
- the ventilation slots are clear and clean. Use a soft brush or a brush with bristles to clean them if necessary.

If you find any damage, you must arrange for it to be rectified by a service center to prevent hazards.

8.4 Ordering spare parts

Please provide the following information when ordering spare parts:

- Type of unit
- Article number of the unit
- ID number of the unit
- Spare part number of the required spare part

For our latest prices and information please go to www.isc-gmbh.info

9. Disposal and recycling

The equipment is supplied in packaging to prevent it from being damaged in transit. The raw materials in this packaging can be reused or recycled. The equipment and its accessories are made of various types of material, such as metal and plastic. Never place defective equipment in your household refuse. The equipment should be taken to a suitable collection center for proper disposal. If you do not know the whereabouts of such a collection point, you should ask in your local council offices.

10. Storage

Store the equipment and its accessories in a dark and dry place at above freezing temperature. The ideal storage temperature is between 5 and 30 °C. Store the electric tool in its original packaging.

11. Transport

CAUTION! Risk of injury!

There is a risk of serious injuries if the equipment is handled improperly.

- The bench-type circular saw is very heavy. Arrange another person to help you when you want to transport the bench-type circular saw.
- Completely dismantle the bench-type circular saw before transporting it.
- Secure the bench-type circular saw against slipping, shocks and vibrations if you transport it in a vehicle.
- As far as possible, use the original packaging for transporting the equipment.

Important!

The warranty certificate is packed separately with the machine.

12. Troubleshooting

Problem	Possible cause	Troubleshooting
The motor of the bench-type circular saw does not start.	The power plug is not connected to the supply.	Insert the power plug.
	The building fuse or the RCCB has tripped.	Check the power cable and, if applicable, the extension cable for damage. Replace the fuse and/or switch it on again (circuit breaker).
	The motor overload cut-out has tripped because the motor is overloaded or has overheated.	Allow the bench-type circular saw to cool for 15-20 minutes.
Poor sawing performance, the saw blade does not run smoothly and/or a lot of dust is produced when sawing.	The saw blade is blunt.	Replace the saw blade with a new one.
A lot of sparks are generated on the motor.	The carbon brushes are defective.	Have the bench-type circular saw checked by a service center.



For EU countries only

Never place electric power tools in your household refuse!

Under European Directive 2012/19/EU concerning old electric and electronic equipment and its implementation in national laws, old electric power tools have to be separated from other waste and disposed of in an environmentally-friendly fashion, e.g. by taking to a recycling depot.

Recycling alternative to the requested returning of equipment:

Instead of returning the equipment to the manufacturer, the owner of the electrical equipment is obliged to ensure that the equipment is properly disposed of if relinquishing ownership. The old equipment can be returned to a suitable collection point that will dispose of the equipment in accordance with the national recycling and waste disposal regulations. This does not apply to any accessories or aids without electrical components supplied with the old equipment.

The reprinting or reproduction by any other means, in whole or in part, of documentation and papers accompanying the products is strictly subject to the express consent of iSC GmbH.

Subject to technical changes

A temporary voltage drop can occur when the equipment starts up, in particular if the power supply quality is poor. These voltage drops can influence other equipment (for example lamps may flicker). If the supply impedance Z_{max} is $< 0.387 \text{ OHM}$, problems of this sort are not to be expected. (Please contact your local electricity supplier for further information).

Konformitätserklärung

- D** erklärt folgende Konformität gemäß EU-Richtlinie und Normen für Artikel
- GB** explains the following conformity according to EU directives and norms for the following product
- F** déclare la conformité suivante selon la directive CE et les normes concernant l'article
- I** dichiara la seguente conformità secondo la direttiva UE e le norme per l'articolo
- NL** verklaart de volgende overeenstemming conform EU richtlijn en normen voor het product
- E** declara la siguiente conformidad a tenor de la directiva y normas de la UE para el artículo
- P** declara a seguinte conformidade, de acordo com as diretiva CE e normas para o artigo
- DK** attesterer følgende overensstemmelse i medfør af EU-direktiv samt standarder for artikel
- S** förklarar följande överensstämmelse enl. EU-direktiv och standarder för artikeln
- FIN** vakuuttaa, että tuote täyttää EU-direktiivin ja standardien vaatimukset
- EE** tõendab toote vastavust EL direktiivile ja standarditele
- CZ** vydává následující prohlášení o shodě podle směrnice EU a norem pro výrobek
- SLO** potrjuje sledečo skladnost s smernico EU in standardi za izdelek
- SK** vydáva nasledujúce prehlásenie o zhode podľa smernice EÚ a noriem pre výrobok
- H** a cikkekhez az EU-irányvonal és Normák szerint a következő konformitást jelenti ki
- PL** deklaruje zgodność wymienionego ponizej artykułu z następującymi normami na podstawie dyrektywy WE.
- BG** декларира съответното съответствие съгласно Директива на ЕС и норми за артикул
- LV** paskaidro šādu atbilstību ES direktīvai un standartiem
- LT** apibūdina šį atitikimą EU reikalavimams ir prekės normoms
- RO** declară următoarea conformitate conform directivei UE și normelor pentru articolul
- GR** δηλώνει την ακόλουθη συμμόρφωση σύμφωνα με την Οδηγία ΕΚ και τα πρότυπα για το προϊόν
- HR** potvrđuje sljedeću usklađenost prema smjernicama EU i normama za artikl
- BIH** potvrđuje sljedeću usklađenost prema smjernicama EU i normama za artikl
- RS** potvrđuje sledeću usklađenost prema smernicama EZ i normama za artikal
- RUS** следующим удостоверяется, что следующие продукты соответствуют директивам и нормам ЕС
- UKR** проголошує про зазначену нижче відповідність виробу директивам та стандартам ЄС на виріб
- MK** ja izjavува следната сообразност согласно EУ-директивата и нормите за артикли
- TR** Ürünü ile ilgili AB direktifleri ve normları gereğince aşağıda açıklanan uygunluğu belirtir
- N** erklærer følgende samsvar i henhold til EU-direktivet og standarder for artikkel
- IS** Lýsir uppfyllingu EU-reglna og annarra staðla vöru

Table Saw F-TS 2000-1 (FERREX)

- 2014/29/EU
- 2005/32/EC_2009/125/EC
- 2014/35/EU
- 2006/28/EC
- 2014/30/EU
- 2014/32/EU
- 2014/53/EU
- 2014/68/EU
- (EU)2016/426
Notified Body:
- (EU)2016/425
- 2011/65/EU_(EU)2015/863
- 2006/42/EC
- Annex IV
Notified Body: 0197, TÜV Rheinland LGA Products GmbH, Tillystraße 2 D, 90437 Nürnberg
Reg. No.: BM 50434377 0001
- 2000/14/EC_2005/88/EC
- Annex V
- Annex VI
Noise: measured L_{WA} = dB (A); guaranteed L_{WA} = dB (A)
P = KW; L/Ø = cm
Notified Body:
- 2012/46/EU_(EU)2016/1628
Emission No.:

**Standard references: EN 62841-1; EN 62841-3-1; EN 60825-1;
EN 55014-1; EN 55014-2; EN 61000-3-2; EN 61000-3-11**

Landau/Isar, den 20.05.2019

Weichselgartner/General-Manager

L. Wentao/Product-Management

First CE: 19
Art.-No.: 43.404.83 I.-No.: 11019
Subject to change without notice

Archive-File/Record: NAPR020935
Documents registrar: Patrick Willnecker
Wiesenweg 22, D-94405 Landau/Isar

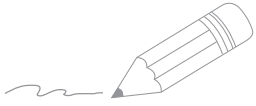

Two horizontal lines are positioned to the right of the pencil's tip, serving as a starting point for writing. Below these, there are 24 additional horizontal lines, evenly spaced, providing a large area for text or drawing.

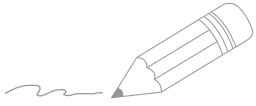

Two horizontal lines are positioned to the right of the pencil's tip, extending across the width of the page. Below these two lines, there are 24 additional horizontal lines, spaced evenly down the page, creating a series of writing lines.



Great care has gone into the manufacture of this product and it should therefore provide you with years of good service when used properly. In the event of product failure within its intended use over the course of the first 3 years after date of purchase, we will remedy the problem as quickly as possible once it has been brought to our attention. In the unlikely event of such an occurrence, or if you require any information about the product, please contact us via our helpline support services, details of which are to be found both in this manual and on the product itself.



PRODUCED IN CHINA FOR:

ALDI STORES LTD. PO BOX 26, ATHERSTONE
WARWICKSHIRE, CV9 2SH.

ALDI STORES (IRELAND) LTD.
PO BOX 726, NAAS, CO. KILDARE.
Visit us at www.aldi.com

AFTER SALES SUPPORT

98780



GB

0044 151 649 1500

IE

0044 1890 946 244



www.einhell.co.uk

MODEL:

F-TS 2000-1

10/2019

3
YEAR
WARRANTY

EH 06/2019 (01)