

**DOCKET NO. 46936**

**APPLICATION OF SOUTHWESTERN §  
PUBLIC SERVICE COMPANY FOR: A §  
CERTIFICATE OF CONVENIENCE §  
AND NECESSITY AUTHORIZING § PUBLIC UTILITY COMMISSION  
CONSTRUCTION AND OPERATION OF §  
WIND GENERATION AND §  
ASSOCIATED FACILITIES IN HALE §  
COUNTY, TEXAS AND ROOSEVELT § OF TEXAS  
COUNTY, NEW MEXICO, AND §  
RELATED RATEMAKING §  
PRINCIPLES; AND APPROVAL OF A §  
PURCHASED POWER AGREEMENT §  
TO OBTAIN WIND GENERATED §  
ENERGY §**

**DIRECT TESTIMONY  
of  
TIM KAWAKAMI**

*on behalf of*

**SOUTHWESTERN PUBLIC SERVICE COMPANY**

*(Filename: KawakamiTXDirect.doc; Total Pages: 215)*

**Table of Contents**

---

---

GLOSSARY OF ACRONYMS AND DEFINED TERMS.....	2
LIST OF ATTACHMENTS .....	4
I. WITNESS IDENTIFICATION AND QUALIFICATIONS .....	5
II. ASSIGNMENT, TESTIMONY SUMMARY AND RECOMMENDATIONS .....	8
III. DESCRIPTION OF THE WIND FACILITIES, PURCHASED POWER AGREEMENT, AND NEGOTIATION PROCESS.....	10
A. FACILITIES AND PPA .....	10
B. CONTRACT NEGOTIATION PROCESS .....	14
C. KEY BONITA PPA TERMS .....	16
AFFIDAVIT .....	22
CERTIFICATE OF SERVICE .....	23
TESTIMONY ATTACHMENTS:	
Attachment TK-1 ( <i>non-native format</i> ).....	24
Attachment TK-2 ( <i>non-native format</i> ).....	126

## **GLOSSARY OF ACRONYMS AND DEFINED TERMS**

<b><u>Acronym/Defined Term</u></b>	<b><u>Meaning</u></b>
Bonita	Bonita Wind Energy, LLC, an entity formed by NextEra Energy Resources LLC
Bonita PPA	Bonita Wind Energy PPA
CCN	Certificate of Convenience and Necessity
COD	Commercial Operation Date
Hale Wind Project	478 MW wind generating facility in Hale County, Texas
IA	Interconnection Agreement
MW	Megawatt
MWh	Megawatt hours
NextEra	NextEra Energy Resources LLC
Operating Companies	Northern States Power Company, a Minnesota corporation; Northern States Power Company, a Wisconsin corporation; PSCo; and SPS
PPA	Purchased Power Agreement
PSCo	Public Service Company of Colorado, a Colorado corporation
PTC	Production Tax Credits
REC	Renewable Energy Credit
Sagamore Wind Project	522 MW wind generating facility in Roosevelt County, New Mexico
SPP	Southwest Power Pool, Inc.
SPS	Southwestern Public Service Company, a New Mexico corporation

<u>Acronym/Defined Term</u>	<u>Meaning</u>
Xcel Energy	Xcel Energy Inc.

## LIST OF ATTACHMENTS

<u>Attachment</u>	<u>Description</u>
TK-1 and TK-1(CONF)	Bonita Wind Energy PPA <i>(Non-native format)</i>
TK-2	SPS Wind Model PPA <i>(Non-native format)</i>

**DIRECT TESTIMONY  
OF  
TIM KAWAKAMI**

1           **I.       WITNESS IDENTIFICATION AND QUALIFICATIONS**

2   **Q.       Please state your name and business address.**

3   A.       My name is Tim Kawakami. My business address is 1800 Larimer St., Suite  
4           1000, Denver, Colorado 80202.

5   **Q.       On whose behalf are you testifying in this proceeding?**

6   A.       I am filing testimony on behalf of Southwestern Public Service Company, a New  
7           Mexico corporation (“SPS”) and wholly-owned electric utility subsidiary of Xcel  
8           Energy Inc. (“Xcel Energy”).

9   **Q.       By whom are you employed and in what position?**

10  A.       I am employed by Xcel Energy Services Inc., the service company subsidiary of  
11           Xcel Energy, as Director of Purchased Power.

12  **Q.       Please briefly outline your responsibilities as Director of Purchased Power.**

13  A.       I manage a staff that is responsible for the negotiation and administration of long-  
14           term purchased power agreements (“PPAs”) for Xcel Energy’s Operating  
15           Companies (Northern States Power Company, a Minnesota corporation; Northern  
16           States Power Company, a Wisconsin corporation; Public Service Company of  
17           Colorado, a Colorado corporation (“PSCo”); and SPS). My group currently  
18           purchases over 11,500 megawatts (“MW”) of electric generation under long-term  
19           contracts, including over 6,600 MW from renewable energy resources, for the  
20           Operating Companies.

1 **Q. Please describe your educational background.**

2 A. I received a Bachelor of Science degree in Agricultural Business from Colorado  
3 State University.

4 **Q. Please describe your professional experience.**

5 A. I began my career with PSCo in 1977 and have served in various positions in gas  
6 and electric distribution, customer service, sales, marketing, and commercial  
7 operations. I have over 30 years of management experience and prior to my  
8 current position I was the chief executive for various unregulated retail companies  
9 for Xcel Energy serving as President of e'prime Retail which sold natural gas to  
10 commercial and industrial customers in Colorado, Florida and Georgia, VP/COO  
11 of XERS Inc. a retail Retail Electric Provider in the Electric Reliability Council of  
12 Texas and President/CEO of Natrogas Inc., a wholesale/retail propane provider in  
13 Minnesota and Wisconsin. I have held my current position as Director of  
14 Purchased Power since June of 2007.

15 **Q. Have you attended or presented any courses or seminars relating to public  
16 utilities or the energy industry?**

17 A. Yes, I have attended various development courses and conferences throughout my  
18 career through utility and industry trade groups, including the Edison Electric  
19 Institute District Managers training held at Georgetown University; a utility  
20 marketing course presented by two Duke University Business School faculty  
21 members and a Utility Finance course at the University of Denver. I have also  
22 attended and presented at multiple wind and solar industry conferences.

1 **Q. Are you associated with any professional organizations?**

2 A. Yes, I am currently a member of the Board of Directors of the American Wind  
3 Energy Association.

4 **Q. Have you testified before any regulatory authorities?**

5 A. Yes. I have testified before the Colorado Public Utilities Commission. In  
6 addition, I have filed testimony before the Public Utility Commission of Texas in  
7 Docket Nos. 38147 and 40824 (prior SPS base rate and fuel reconciliation cases),  
8 the New Mexico Public Regulation Commission, on matters regarding SPS's  
9 resource planning and acquisition processes, SPS's acquisition of firm purchased  
10 power, and the reasonableness and prudence of SPS's PPAs. I have also filed  
11 testimony before the Minnesota Public Utilities Commission.

1                                   **II.     ASSIGNMENT, TESTIMONY SUMMARY AND**  
2   **RECOMMENDATIONS**

3   **Q.     What are your assignments in this proceeding?**

4   A.     My testimony will address the terms and conditions of the Bonita Wind Energy,  
5           LLC (“Bonita”) PPA (“Bonita PPA”) for the purchase of wind power from two  
6           different locations referred to as Phase I (approximately 80 MW) and Phase II  
7           (approximately 150 MW). I will support the reasonableness of the terms and  
8           conditions of the PPA and address the contract negotiation process.

9   **Q.     Please summarize the recommendations and conclusions in your testimony.**

10  A.     On March 7, 2017, SPS entered into the Bonita PPA for a total of approximately  
11           230 MW of wind energy.<sup>1</sup> The Bonita PPA includes two projects: Phase I in  
12           Crosby County, Texas with approximately 80 MW and Phase II in Cochran  
13           County with approximately 150 MW. The estimated commercial operation date  
14           (“COD”) for both Phase I and Phase II is no sooner than October 2, 2018, and no  
15           later than December 31, 2018. The Bonita PPA will provide SPS with  
16           approximately 1,029,563 megawatt hours (“MWh”) of economically priced  
17           energy per year over the 30-year term of the contract for both phases. The  
18           opportunity for the purchase arose in the course of pursuing a low cost wind  
19           portfolio for SPS’s service territory. SPS’s evaluation and negotiation of the  
20           Bonita PPA ensures that the negotiated rate is beneficial for customers. The terms  
21           and conditions of the Bonita PPA are reasonable and will permit SPS to obtain

---

<sup>1</sup> A copy of the PPA is provided in Attachments TK-1 and TK-1(CONF). Certain provisions of the Bonita PPA are confidential and are being provided in Attachment TK-1(CONF). Mr. Kawakami’s confidential attachment will be provided to all parties that sign the Confidentiality Agreement under the proposed Protective Order filed in this docket.



1 low cost energy that will benefit its customers. Additionally, the Bonita PPA is a  
2 pay for performance agreement and is based on SPS's Wind Model PPA,  
3 provided as Attachment TK-2. This PPA will provide economic benefits for SPS  
4 customers as discussed by SPS witness Jonathan Adelman. SPS requests  
5 approval of this PPA in this proceeding.

6 **Q. Who is the counterparty to the PPA?**

7 A. Bonita Wind Energy, LLC, a company formed by NextEra Energy Resources  
8 LLC ("NextEra").

9 **Q. Are Attachments TK-1, TK-1(CONF), and TK-2 true and correct copies of**  
10 **the documents you represent them to be in your testimony?**

11 A. Yes.

1           **III. DESCRIPTION OF THE WIND FACILITIES, PURCHASED**  
2           **POWER AGREEMENT, AND NEGOTIATION PROCESS**

3   **A. Facilities and PPA**

4   **Q. Please generally describe NextEra’s Bonita Phase I and Phase II facilities**  
5   **and the PPA regarding those facilities.**

6   A. The Bonita Phase I facility is a new approximately 80 MW wind facility located  
7   in Crosby County, Texas. The Bonita Phase II facility is a new approximately  
8   150 MW wind facility located in Cochran County, Texas. Facility descriptions  
9   and site maps are provided as Exhibit C to Attachment TK-1. The site maps show  
10   the geographic location of each facility and proposed siting of turbines and other  
11   components within each facility. Construction will begin in early 2018 and the  
12   expected COD for both phases is estimated to be no sooner than October 2, 2018,  
13   and no later than December 31, 2018. Construction milestones are listed in  
14   Exhibit B of Attachment TK-1. SPS expects the facilities to produce a combined  
15   approximately 1,029,563 MWh per calendar year. The Bonita PPA between SPS  
16   and Bonita LLC, owned by NextEra, addresses the pricing and terms and  
17   conditions of both the Phase I and Phase II facilities. The Bonita PPA is a pay for  
18   performance agreement.

19           The Bonita PPA was signed on March 7, 2017 and is part of a larger  
20   transaction between SPS and NextEra for which SPS is requesting that a  
21   Generation Certificate of Convenience and Necessity (“CCN”) be granted in this  
22   proceeding for the SPS-owned Hale Project as discussed in the direct testimony of  
23   SPS witnesses David T. Hudson and Riley Hill.

1 **Q. Are there any permitting requirements necessary for the Bonita PPA?**

2 A. Yes. The Bonita PPA lists the permits required in Exhibit F of Attachment TK-1.  
3 Obtaining the permits is the responsibility of Bonita, the developer.

4 **Q. Please explain how the Bonita PPA was selected and whether SPS considered**  
5 **whether a utility-owned generation resource could have been constructed as**  
6 **an alternative with a greater benefit to ratepayers.**

7 A. The opportunity for the Bonita PPA arose in the course of pursuing a low cost  
8 wind portfolio for SPS. As further discussed by Mr. Hudson, SPS determined that  
9 it had an opportunity to achieve long-term benefits for its customers through the  
10 development and ownership of wind generation facilities. To provide these  
11 benefits for customers, SPS needed to act quickly to qualify for the maximum  
12 level of available production tax credits (“PTC”) which are set to ramp down and  
13 expire over the next few years. For further discussion of the PTCs and the timing  
14 of finalizing this project, please refer to Mr. Hudson’s direct testimony.

15 As further explained below, SPS’s options for wind project sites were  
16 limited. SPS identified the Hale site and Bonita sites as some of the few available  
17 sites for the wind development due to existing interconnections with the  
18 Southwest Power Pool, Inc. (“SPP”). SPS had a preference for owning the entire  
19 Hale site for three reasons. First, it creates scale opportunities to reduce cost of  
20 construction and maintenance. Second, the contractual and construction logistics  
21 of splitting the ownership were challenging. Third, in the October 2016 time  
22 frame, Xcel Energy obtained power factors for Vestas turbines that would further

1 improve the economics of company-owned projects and, as a result, believed that  
2 additional wind would create greater benefits to our customers.

3 Consequently, our early discussions with NextEra involved a request to  
4 purchase the entire Hale project site for a 478 MW wind facility in Hale County,  
5 Texas (the “Hale Wind Project”). NextEra, however, was interested in a split  
6 development of the Hale site with a portion provided through a PPA and a portion  
7 through ownership by SPS. SPS continued to push for obtaining the entire Hale  
8 site. Ultimately, NextEra was amenable to SPS obtaining ownership of the entire  
9 Hale site if the construct that included a roughly 200 MW PPA could be  
10 maintained, and suggested the Bonita project as a means to achieve this goal.  
11 Similar to the construct that had been discussed for a split ownership of Hale,  
12 which had necessitated linkage of regulatory approvals of part SPS ownership  
13 and part PPA, SPS and NextEra agreed to approach the new construct (SPS  
14 owning the Hale Project, and SPS and NextEra entering into the Bonita PPA) in  
15 the same manner.

16 As discussed by Mr. Adelman, SPS evaluated the benefits of the Bonita  
17 PPA as part of the overall agreement for wind facilities including the Bonita PPA,  
18 the Hale Wind Project, and the Sagamore project, a 522 MW wind generating  
19 facility in Roosevelt County, New Mexico (“Sagamore Wind Project”). Based on  
20 that analysis, it was determined that the proposed PPA provided an opportunity to  
21 purchase energy at a relatively low price point to add to SPS’s portfolio of low-  
22 cost energy as part of the overall initiative. Accordingly, the decision was made  
23 to pursue this economic opportunity for the benefit of customers. Mr. Adelman

1 discusses the economic analyses performed and the overall dollar savings of the  
2 entire initiative for the benefit of SPS's customers.

3 **Q. Please explain SPS's identification of sites as potential candidates for**  
4 **purchase and development of wind projects.**

5 A. When the decision was made to pursue the SPS wind initiative, SPS focused on  
6 finding sites that were in SPS's system and had also made a generation  
7 interconnection application with the SPP or had a completed interconnection  
8 agreement. This was important to ensure a project could be in service by 2020 to  
9 meet the deadline to earn the PTCs because the time for the SPP generation  
10 interconnection study to be completed prior to construction can take several  
11 months, as further discussed in the direct testimony of SPS witness William A.  
12 Grant. A list of potential projects was developed using the public SPP  
13 interconnection queue list sorted by utility, state, and size.

14 As SPS vetted these potential wind projects, it became apparent that  
15 project opportunities were very limited due to unknown transmission upgrade  
16 costs and system congestion risk. Because of that, SPS focused on the southern  
17 portion of SPS's system. Only a handful of available sites or projects either had  
18 an existing interconnection agreement ("IA") or had favorable interconnection  
19 queue positions with SPP.

20 **Q. What happened after SPS identified potential projects in the SPP generator**  
21 **interconnection queue?**

22 A. SPS contacted developers to discuss whether wind development rights could be  
23 acquired. These discussions led to the selection of the Hale and Sagamore Wind

1 Projects. The Hale site and the Bonita Crosby site were the only available sites in  
2 the southern region that had existing IAs, known transmission upgrade costs, and  
3 the least congestion risk. SPS also identified the Bonita Cochran site and the  
4 Sagamore site as available sites with lower congestion risk and favorable  
5 interconnection queue positions, which enables SPS to make decisions regarding  
6 the sites sooner than projects later in the interconnection queue.

7 **Q. Will SPS's customers benefit from the Bonita PPA?**

8 A. Yes. The Bonita PPA is a key component of the wind facility initiative consisting  
9 of the Bonita PPA and the Hale Wind Project as well as our overall initiative  
10 including the Sagamore Wind Project. The Bonita PPA was identified through  
11 our negotiation process as an opportunity to procure long-term economic energy  
12 as part of this overall initiative as further discussed by Mr. Adelman and shown in  
13 the analyses he presents. Together, all of these projects complete the initiative to  
14 provide long-term economic energy to SPS's customers.

15 **B. Contract Negotiation Process**

16 **Q. Please briefly describe the contract negotiation process.**

17 A. The contract negotiation process is designed to achieve reasonable contract terms  
18 as defined in the SPS Wind Model PPA and based on the energy knowledge and  
19 experience of SPS personnel. SPS negotiated with Bonita to ensure the terms and  
20 conditions resulted in a PPA for the benefit of customers, and closely followed the  
21 SPS Wind Model PPA. Where potential deviations from the SPS Wind Model  
22 PPA were proposed, SPS evaluated the issue or the specific term or condition and,  
23 where appropriate, consulted with internal subject matter experts to receive input

1 and/or acceptance to ensure the change did not compromise the intent of the  
2 provision or unnecessarily shift risks to SPS. Formal negotiations began on  
3 January 13, 2017 and were completed on February 21, 2017. The Bonita PPA  
4 was executed on March 7, 2017. A copy of the executed PPA is provided in  
5 Attachments TK-1. A copy of the SPS Wind Model PPA used in the negotiation  
6 process is provided in Attachment TK-2.

7 **Q. Please generally describe the SPS Wind Model PPA and how it was used for**  
8 **the Bonita PPA.**

9 A. The SPS Wind Model PPA terms are considered Xcel Energy's standards for  
10 what should be included in PPAs based on determinations of best practices,  
11 current industry practices, lessons learned and the knowledge of Xcel Energy or  
12 SPS personnel based on of years of negotiation and managing PPAs. Deviations  
13 from or adaptations of this SPS Wind Model PPA can be appropriate based on the  
14 individual circumstances of each deal, but are carefully reviewed to ensure they  
15 are appropriate and beneficial to the overall agreement.

16 The SPS Wind Model PPA provisions include, among others, the  
17 commercial operation of the facility, the delivery and metering of the wind energy  
18 produced, and terms and conditions related to the price of the wind energy. In  
19 addition, the SPS Wind Model PPA establishes performance criteria for operating  
20 and maintaining the facility, financial security requirements, contract  
21 administrative and notice requirements, and assignment and other transfer  
22 restrictions. The SPS Wind Model PPA also defines events of default, force  
23 majeure, and other representations and warranties.

1 **Q. Please describe any material differences in the Bonita PPA in comparison to**  
2 **the SPS Wind Model PPA and the reasons for those differences.**

3 A. The material differences from the model PPA are:

- 4 • A termination right for certain policy changes.
- 5 • A termination right if the Hale Purchase and Sale Agreement isn't  
6 finalized or approved.
- 7 • SPS is not purchasing the renewable energy credits ("RECs") in this  
8 agreement but retains an option to purchase RECs at a later date.

9 **Q. Did the contract negotiation process help to ensure the Bonita PPA is**  
10 **beneficial to customers?**

11 A. Yes, for the reasons explained above.

12 **C. Key Bonita PPA Terms**

13 **Q. What is the term of the Bonita PPA?**

14 A. The term of the Bonita PPA is 30 years, beginning on the COD. The Bonita PPA  
15 is subject to potential early termination for reasons including failure to obtain  
16 state regulatory approval of the Bonita PPA or the purchase and sale agreement  
17 and other definitive agreements related to the Hale Wind Project, subject to  
18 certain conditions; and event(s) of default as defined in the contract. The Bonita  
19 PPA includes no provisions for extension of the term.

20 **Q. What is the nameplate capacity and amount of energy to be purchased under**  
21 **the PPA?**

22 A. The Bonita PPA includes two projects: Phase I in Crosby County with  
23 approximately 80 MW and Phase II in Cochran County with approximately 150  
24 MW. Together they are expected to produce approximately 1,029,563 MWh per



1 year, with an average monthly production of approximately 85,797 MWh per  
2 month.

3 **Q. Please describe the pricing under the Bonita PPA.**

4 A. The levelized price over the 30-year term is \$22.40/MWh. The Energy Payment  
5 Rate, detailed in Exhibit J to the Bonita PPA, starts at \$18.10 the first year and  
6 escalates at 2% annually. The Test Energy Payment Rate is 70% of the Energy  
7 Payment Rate for the first Commercial Operation Year.

8 **Q. Are there any capacity costs, fixed or variable administrative costs,**  
9 **transactional, or operation and maintenance costs that SPS will be required**  
10 **to pay under the Bonita PPA?**

11 A. No. All of SPS's costs under the Bonita PPA are related to energy received,  
12 compensable curtailments, and transmission service (including losses).

13 **Q. Earlier you mentioned that this Bonita PPA is a pay for performance**  
14 **agreement. Please explain what that means and how that works with**  
15 **compensable curtailments.**

16 A. The Bonita PPA is structured such that SPS is not required to make any payment  
17 for the capacity of the Bonita facilities or to make a minimum energy payment.  
18 All payments made pursuant to the Bonita PPA are made for performance of the  
19 Bonita facilities, i.e. when the facilities produce energy, an energy payment is  
20 made. This PPA structure imbeds a performance incentive in the transaction – if  
21 the wind turbines are not available for energy production, no energy payments are  
22 made. Conversely, when Bonita's wind turbines are maintained and operated

1 such that they are available to produce energy, then energy payments are made in  
2 accordance with the terms of the Bonita PPA.

3 Payment is also made for energy from the Bonita facilities for  
4 compensable curtailment events. These events occur when the facilities are  
5 available and producing energy but: (1) SPS chooses to curtail the facility for  
6 economic reasons; or (2) SPS elects to use non-firm transmission service and the  
7 non-firm transmission service is restricted or reduced by the applicable  
8 transmission service provider (to the extent such restriction or reduction would  
9 not have been imposed even if firm transmission service had been in place).

10 **Q. Does SPS have any obligation to pay insurance-related costs under the**  
11 **Bonita PPA?**

12 A. No. However, Bonita is required to maintain certain insurance coverage as set  
13 forth in Exhibit E of Attachment TK-1 and SPS is to be named as an additional  
14 insured.

15 **Q. Are there any security guarantees under the Bonita PPA?**

16 A. Yes. Under Article 11 of the Bonita PPA, Bonita is required to establish, fund,  
17 and maintain a Security Fund that is available to pay any amount due to SPS  
18 pursuant to the PPA, and to provide SPS security that Bonita will satisfy  
19 obligations under the PPA. Bonita is required to replenish the Security Fund if  
20 SPS makes a draw on the Security Fund. However, Bonita is not required to  
21 replenish the Security Fund to a level in excess of the remaining amount of the  
22 applicable Damage Cap. The Damage Cap is discussed further below.

1 **Q. Describe the Bonita PPA provisions that relate to non-performance by**  
2 **Bonita.**

3 A. The parties are obligated to comply with the general terms and conditions of the  
4 PPA. Default by Bonita is defined in Article 12 of the Bonita PPA along with the  
5 cure period for each type of default and the remedies for Events of Default. A  
6 default becomes an Event of Default if not cured by the cure period, or  
7 immediately if no cure period exists. In connection with any default by Bonita  
8 under Section 12.1, whether or not the default was cured by Bonita, SPS may: (1)  
9 seek actual damages in such amounts and on such basis for the default as  
10 authorized by the Bonita PPA; (2) offset against any payments due to Bonita, any  
11 actual damages and other amounts due from Bonita; and (3) draw any actual  
12 damages and other amounts due from Bonita, from the security fund.  
13 Additionally, upon and at any time following an Event of Default by Bonita, SPS  
14 may terminate the Bonita PPA immediately upon notice to Bonita without penalty  
15 or further obligation to Bonita; alternatively, SPS has the right to specific  
16 performance.

17 Default by Bonita for Failure to Achieve the Commercial Operation Date  
18 is separately defined in Section 12.2. Bonita is liable to pay \$57,500 per day as  
19 liquidated delay damages, subject to the terms of the Bonita PPA.

20 **Q. Please describe the Damage Cap under the Bonita PPA.**

21 A. The Damage Cap is \$17.25 million for Bonita's aggregate financial liability to  
22 SPS for Actual Damages following COD, as discussed in Section 12.4 of the  
23 Bonita PPA. If damages exceed this amount and Bonita does not agree to pay the

1 damages, SPS may terminate the Bonita PPA upon notice. Certain events as  
2 defined in Section 12.4 of the Bonita PPA are not subject to this damage cap.

3 **Q. Does the Bonita PPA require SPS to accept energy above committed levels?**

4 A. No. The Bonita PPA does not establish a level of committed energy. The Bonita  
5 PPA, however, does establish an energy purchase limit based on the facility's  
6 Nameplate Capacity. Section 8.1 of the Bonita PPA states that SPS shall never be  
7 required to pay for net instantaneous output of the Facility (as measured at the  
8 Point of Delivery) in excess of the Nameplate Capacity (Bonita must certify the  
9 final actual Nameplate Capacity of the Facility promptly following COD).

10 **Q. Please describe the PPA provisions that relate to delivery of the energy and,  
11 in particular, any transmission-related costs that SPS is obligated to pay.**

12 A. Section 5.1 of the Bonita PPA specifies that Bonita is responsible for the costs  
13 associated with the interconnection of the Phase I and Phase II Bonita Facilities.  
14 Bonita is responsible for all costs and losses for delivering energy to the Point of  
15 Delivery. SPS is responsible for all electric losses, transmission and ancillary  
16 service arrangements, and costs required to transmit and deliver energy beyond  
17 the Point of Delivery, including the costs of any system upgrades required to  
18 secure firm transmission service for deliveries of energy beyond the Point of  
19 Delivery. The costs of transmission upgrades are discussed by Mr. Grant.

20 **Q. Please discuss the REC purchase option under the PPA.**

21 A. SPS has the option to purchase all RECs associated with the project by providing  
22 Bonita with a 12-month notice of its intent to do so. Once notice is given, REC  
23 purchases will be for the duration of the term at a rate of \$1.05 per REC. Bonita

1 has the right to sell the RECs to a third party, provided it supplies SPS with a  
2 notice of its intent to do so and SPS elects not to enforce its REC Right of First  
3 Offer.

4 **Q. Are the terms and conditions of the Bonita PPA fair and reasonable?**

5 A. Yes. Based on my experience with PPAs, the consistency with the SPS Wind  
6 Model PPA and the analyses of Mr. Adelman, these terms and conditions are fair  
7 and reasonable and beneficial for SPS customers.

8 **Q. Is SPS requesting approval of the Bonita PPA in this proceeding?**

9 A. Yes. For the reasons set forth above, and discussed by Mr. Hudson, Mr.  
10 Adelman, and SPS witness Evan D. Evans, the Bonita PPA should be approved in  
11 this proceeding.

12 **Q. Does this conclude your pre-filed direct testimony?**

13 A. Yes.

**AFFIDAVIT**

STATE OF COLORADO        )  
  )  
COUNTY OF DENVER        )

TIM KAWAKAMI, first being sworn on his oath, states:

I am the witness identified in the preceding testimony. I have read the testimony and the accompanying attachments and am familiar with their contents. Based upon my personal knowledge, the facts stated in the testimony are true. In addition, in my judgment and based upon my professional experience, the opinions and conclusions stated in the testimony are true, valid, and accurate.

  
\_\_\_\_\_  
TIM KAWAKAMI

Subscribed and sworn to before me this 9<sup>TH</sup> day of March, 2017 by TIM KAWAKAMI.

CHRISTINA M FALCE  
NOTARY PUBLIC  
STATE OF COLORADO  
NOTARY ID 19904006701  
MY COMMISSION EXPIRES JUNE 24, 2020

  
\_\_\_\_\_  
Notary Public, State of Colorado  
My Commission Expires: 6-24-2020

**CERTIFICATE OF SERVICE**

I certify that on March 21, 2017, this instrument was filed with the Public Utility Commission of Texas, and a true and correct copy of it was served by hand delivery on the Staff of the Public Utility Commission of Texas and the Office of Public Utility Counsel, and by hand delivery, next business day courier delivery, or first class mail on each party of record in SPS's most recent base rate case, Docket No. 45524.

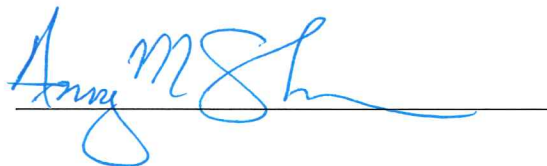
A handwritten signature in blue ink is written over a horizontal line. The signature appears to be "Amy M. Sh..." with a large, stylized flourish at the end.

[Execution Version]

# WIND ENERGY PURCHASE AGREEMENT

BETWEEN

**SOUTHWESTERN PUBLIC SERVICE COMPANY**

AND

**BONITA WIND ENERGY, LLC**



- March 7, 2017 -



**TABLE OF CONTENTS**

	<b>PAGE</b>
<b>Article 1 - Rules of Interpretation.....</b>	<b>1</b>
1.1 Interpretation.....	1
1.2 Interpretation with Other Agreements .....	2
1.3 Good Faith and Fair Dealing.....	2
<b>Article 2 – Term and Termination.....</b>	<b>2</b>
<b>Article 3 – Facility Description .....</b>	<b>3</b>
3.1 Description.....	3
3.2 General Design of the Facility.....	3
<b>Article 4 - Implementation .....</b>	<b>3</b>
4.1 Project Development.....	3
4.2 Environmental Matters .....	4
4.3 Permits.....	5
4.4 Governmental Inspections .....	6
4.5 Commercial Operation.....	7
4.6 Test Energy .....	8
<b>Article 5 - Delivery.....</b>	<b>9</b>
5.1 Arrangements .....	9
5.2 Market Changes .....	9
5.3 Electric Metering Devices .....	10
<b>Article 6 – Conditions Precedent .....</b>	<b>11</b>
6.1 State Regulatory Approval .....	11
6.2 Other Company CPs.....	12
6.3 Seller CPs.....	12
<b>Article 7 – Sale and Purchase .....</b>	<b>13</b>
7.1 General Obligation .....	13
7.2 AGC.....	13
7.3 Green Benefits.....	13
7.4 Ancillary Services .....	14
<b>Article 8 – Payment Calculations.....</b>	<b>15</b>
8.1 Payment for Renewable Energy .....	15
8.2 Reserved .....	15
8.3 Curtailment .....	15
<b>Article 9 – Billing and Payment.....</b>	<b>17</b>
9.1 Billing .....	17
9.2 Payment.....	18
9.3 Billing Disputes.....	18

<b>Article 10 – Operations and Maintenance .....</b>	<b>18</b>
10.1 Operation and Administration .....	18
10.2 Facility Maintenance .....	19
10.3 Books and Records .....	19
10.4 Access to Facility .....	19
10.5 Real Time Data.....	20
10.6 Accreditation .....	20
10.7 Operating Committee and Operating Procedures.....	20
<b>Article 11 – Security for Performance .....</b>	<b>21</b>
11.1 Security Fund.....	21
11.2 Replenishment.....	21
11.3 Form .....	22
11.4 Replacement.....	23
11.5 Survival .....	24
11.6 Expenses.....	24
<b>Article 12 – Default and Remedies.....</b>	<b>24</b>
12.1 Default by Seller: General.....	24
12.2 Default by Seller: Failure to Achieve COD .....	27
12.3 Default by Company .....	27
12.4 Limitations on Damages .....	29
12.5 Step-In Rights .....	30
12.6 Bankruptcy.....	32
12.7 Cumulative Remedies.....	32
12.8 Duty to Mitigate.....	32
<b>Article 13 – Dispute Resolution .....</b>	<b>32</b>
13.1 Negotiation.....	32
13.2 Time Bar .....	33
13.3 No Termination Pending Dispute Resolution .....	33
13.4 Governing Law.....	34
13.5 Venue .....	34
13.6 Waiver of Jury Trial.....	34
<b>Article 14 – Force Majeure.....</b>	<b>34</b>
14.1 Definition.....	34
14.2 Applicability of Force Majeure.....	35
14.3 Limitations on Effect of Force Majeure .....	35
<b>Article 15 – Representations and Warranties .....</b>	<b>36</b>
<b>Article 16 - Insurance.....</b>	<b>37</b>
16.1 Evidence of Insurance .....	37
16.2 Policy Requirements.....	37
16.3 No Implied Limitation .....	38
16.4 Term and Modification of Insurance.....	38

16.5	Application of Proceeds .....	38
<b>Article 17 - Indemnity .....</b>		<b>38</b>
17.1	Indemnification: General .....	38
17.2	Indemnification: Environmental .....	39
17.3	Limitations.....	39
17.4	Procedures .....	39
17.5	Amounts Owed .....	40
<b>Article 18 – Lender Provisions .....</b>		<b>40</b>
18.1	Accommodation of Facility Lender .....	40
18.2	Notices.....	40
<b>Article 19 - Assignment .....</b>		<b>41</b>
19.1	Assignment by Seller .....	41
19.2	Assignment by Company .....	42
19.3	ROFO .....	42
19.4	PFT .....	43
19.5	Option .....	45
19.6	Reserved .....	46
<b>Article 20 - Miscellaneous .....</b>		<b>47</b>
20.1	Notices.....	47
20.2	Taxes .....	47
20.3	Applicable Laws .....	48
20.4	Fines and Penalties .....	48
20.5	Rate Changes.....	48
20.6	Certifications .....	49
20.7	Disclaimer of Third Party Beneficiaries .....	49
20.8	Relationship of the Parties .....	49
20.9	Survival of Obligations .....	49
20.10	Severability .....	49
20.11	Complete Agreement; Amendments.....	50
20.12	Waiver.....	50
20.13	Binding Effect.....	50
20.14	Headings.....	50
20.15	Counterparts .....	50
20.16	Press Release .....	50
20.17	Exhibits .....	50
20.18	Confidentiality .....	50

EXHIBIT A	DEFINITIONS
EXHIBIT B	CONSTRUCTION MILESTONES
EXHIBIT C	FACILITY DESCRIPTION AND SITE MAPS
EXHIBIT D	NOTICES AND CONTACT INFORMATION

EXHIBIT E INSURANCE COVERAGE  
EXHIBIT F SELLER'S NEEDED PERMITS  
EXHIBIT G FORM OF LETTER OF CREDIT  
EXHIBIT H FORM OF GUARANTY  
EXHIBIT I AGC PROTOCOLS; DATA COLLECTION; TECHNICAL SPECS  
EXHIBIT J ENERGY PAYMENT RATE  
EXHIBIT K LENDER CONSENT PROVISIONS  
EXHIBIT L CURTAILMENT ADMINISTRATION PROTOCOLS  
EXHIBIT M MECHANICAL AVAILABILITY PERCENTAGE

**WIND ENERGY PURCHASE AGREEMENT  
BETWEEN  
SOUTHWESTERN PUBLIC SERVICE COMPANY  
AND  
BONITA WIND ENERGY, LLC**

This Wind Energy Purchase Agreement (this "PPA") is made as of this 7<sup>th</sup> day of March 2017 (the "Effective Date"), by and between (i) **Southwestern Public Service Company**, a New Mexico corporation with a principal place of business at 1800 Larimer Street, Denver, CO 80202 ("Company"), and (ii) **Bonita Wind Energy, LLC**, a Delaware limited liability company with a principal place of business at 700 Universe Boulevard, Juno Beach, FL 33418 ("Seller"). Company and Seller are hereinafter referred to individually as a "Party" and collectively as the "Parties;" and

WHEREAS Seller desires to develop, design, construct, interconnect, own, operate and maintain an approximately 230 MW wind generation project consisting of an approximately 80 MW component ("Phase I"), and an approximately 150 MW component ("Phase II", the Phase I component and the Phase II component, jointly the "Facility"); and

WHEREAS, in accordance with this PPA, Seller desires to sell and deliver, and Company desires to accept and receive, certain products and services generated and delivered from the Facility (as such Facility is detailed herein) to the Point of Delivery at the prices and on the terms and conditions set forth in this PPA.

NOW THEREFORE, in consideration of the mutual covenants herein contained, the sufficiency and adequacy of which are hereby acknowledged, the Parties agree to the following:

**Article 1 - Rules of Interpretation**

1.1 Interpretation.

(A) Capitalized terms listed in this PPA shall have the meanings set forth in Exhibit A - Definitions or as otherwise defined in this PPA, whether in the singular or the plural or in the present or past tense. Words not otherwise defined in this PPA shall (i) have meanings as commonly used in the English language, (ii) be given their generally accepted meaning consistent with Good Utility Practice, and (iii) be given their well-known and generally accepted technical or trade meanings.

(B) The following rules of interpretation shall apply: (1) The masculine shall include the feminine and neuter; (2) references to "Articles," "Sections" or "Exhibits" shall be to articles, sections, or exhibits of this PPA except as the context may otherwise require; (3) all Exhibits are incorporated into this PPA (*provided, however, that in the event of a conflict with the terms of this PPA, the PPA shall control*); and (4) use of the words "include" or "including" or similar words shall be interpreted as "include without limitation" or "including, without limitation."

(C) This PPA was negotiated and prepared by both Parties with the advice and participation of counsel. None of the provisions hereof shall be construed against one Party on the ground that such Party is the author of this PPA or any part hereof.

## 1.2 Interpretation with Other Agreements.

(A) This PPA does not provide Seller authorization to interconnect the Facility or inject power into the Transmission Authority's System. Seller shall contract for interconnection services in accordance with the applicable Transmission Tariff. Seller acknowledges that the Interconnection Agreement is/will be a separate contract and that (i) this PPA is not binding on the Transmission Authority, (ii) this PPA does not create any rights between Seller and the Transmission Authority, and (iii) the Interconnection Agreement does not modify the Parties' rights and obligations under this PPA. The applicable Transmission Authority shall be deemed to be a separate and unaffiliated contracting party for purposes of this PPA, regardless whether such Transmission Authority is Company or an Affiliate of Company.

(B) This PPA does not provide for the supply of retail power for purposes of operating the Facility, including start-up, shut-down, oil heating, turbine adjustment, HVAC or any other purpose ("House Power"). Seller shall contract with the utility providing House Power to the Site (the "Local Provider") for the supply of House Power. Seller acknowledges that (i) Seller must obtain House Power for each of the Phase I and Phase II components of the Facility independently, (ii) this PPA is not binding on the Local Provider, (iii) this PPA does not create any rights between Seller and the Local Provider, and (iv) Seller's contract for House Power does not affect the Parties' rights and obligations under this PPA. For purposes of this PPA, the Local Provider shall be deemed to be a separate and unaffiliated contracting party regardless whether the Local Provider is Company or an Affiliate of Company; *provided that*, if (and only if) the Local Provider is Company or an Affiliate of Company, Seller may obtain House Power by self-generating and netting such self-generation from the Contract Energy provided to Company unless prohibited by Applicable Law.

1.3 Good Faith and Fair Dealing. The Parties shall act reasonably and in accordance with the principles of good faith and fair dealing in the performance of this PPA. Unless expressly provided otherwise in this PPA, (a) when this PPA specifically references the consent, approval, or similar action by a Party, such consent or approval shall not be unreasonably withheld, conditioned or delayed, and (b) wherever this PPA specifically gives a Party a right to determine, require, specify or take similar action with respect to a matter, such determination, requirement, specification or similar action shall be Commercially Reasonable.

## **Article 2 - Term and Termination**

This PPA shall become effective as of the date of its execution, and shall remain in full force and effect until 11:59 pm on the 30<sup>th</sup> anniversary of the Commercial Operation Date (the "Scheduled Termination Date"), subject to early termination as

provided in this PPA. Applicable provisions of this PPA shall continue in effect after termination to the extent necessary to (i) provide for final billings, payments and adjustments, (ii) enforce or complete the duties, obligations or responsibilities of the Parties (including under Sections 12.1(B)-(D), Section 12.2(C), Sections 12.3(B)-(D), Section 12.4, Article 13 and Article 17 below), and (iii) address any remedies or indemnifications arising prior to termination.

### **Article 3 - Facility Description**

3.1 Description. Seller shall construct, interconnect, own, operate, and maintain each of the Phase I and Phase II components of the Facility, as further described in Exhibit C - Facility Description. A scaled map that identifies the Site for each of the Phase I and Phase II components of the Facility, the location of the Facility, the Interconnection Point and Interconnection Facilities, the Delivery Points for each of the Phase I and Phase II components of the Facility, and other important facilities, is included in Exhibit C - Facility Description.

#### 3.2 General Design of the Facility.

(A) Seller shall cause the design, construction, operation and maintenance of the Facility in accordance with Good Utility Practices and the Interconnection Agreement.

(B) The Facility shall include all equipment specified in Exhibit C - Facility Description for each of the Phase I and Phase II components and otherwise necessary to fulfill Seller's obligations under this PPA, including all equipment necessary (i) to meet the requirements of Exhibit I - Operating Standards, and (ii) to interconnect successfully with the Transmission Authority's System for the delivery of Renewable Energy to the Point of Delivery.

(C) The Nameplate Capacity of the Facility (the aggregate of the Phase I and Phase II components) shall be 230 MW (+/- the increment of one Wind Turbine more or less). Seller shall certify to Company the final actual Nameplate Capacity of the Facility promptly following COD.

### **Article 4 - Implementation**

#### 4.1 Project Development.

(A) Seller shall enter into and perform at its expense all contracts required for (i) the engineering, procurement, construction, acquisition, manufacture, delivery and installation of the Facility, and (ii) the generation and delivery of Renewable Energy from the Facility to the Point of Delivery (generally, the "Construction Contract(s)") with qualified and experienced contractors. Upon written request by Company, Seller shall provide a memorandum of agreement executed by Seller and the contracting party related to a Construction Contract. Such memorandum of agreement shall set forth the basic terms of such contract, including the names of the parties thereto, the date of such contract, a summary of any products or services to be provided

and other information reasonably sufficient for Company to determine that the Construction Contract contains those obligations necessary for Seller to satisfy the Construction Milestones. All such memorandum or any Construction Contracts obtained by Company shall be deemed Confidential Information subject to Section 20.18 below.

(B) In its efforts to achieve COD, Seller shall use Commercially Reasonable Efforts to achieve the milestones set forth in Exhibit B – Construction Milestones, and shall notify Company promptly following achievement of each such milestone.

(C) Prior to the Commercial Operation Date, Seller shall (i) submit monthly progress reports to Company in a form agreed by the Parties, advising Company of the current status of each Construction Milestone, any significant developments or delays (along with an action plan for making up delays), and Seller's best estimate of the Commercial Operation Date; (ii) if applicable, provide copies of reports submitted to the Facility Lender relating to status, progress and development of the Facility, and (iii) invite Company to participate in monthly meetings to discuss the progress reports, answer questions, and assess the schedule. Upon the Company's reasonable prior written request and during normal business hours, Seller shall make all relevant counterparties under the Construction Contracts available to Company in order to keep Company fully informed on the development status of the Facility.

(D) Upon the Company's reasonable prior written request and during normal business hours, Company shall have the right to monitor the construction, start-up, testing, and operation of the Facility at the Site to verify compliance with this PPA, *provided, however*, that Company shall comply with all of Seller's applicable safety and health rules and requirements.

(E) Neither Company's review of Construction Contracts and Seller's reports, nor its discussions with Seller and its contractors, nor its monitoring of development and construction the Facility, shall be construed as endorsement by Company of the design, engineering, construction or testing thereof nor as any express or implied warranty as to the performance, safety, durability, or reliability of the Facility.

#### 4.2 Environmental Matters.

(A) No later than 60 Days following satisfaction or waiver of the last Condition Precedent set forth in Article VI hereof, Seller shall provide to Company a completed independent "Phase I" environmental investigation of the Site that meets ASTM 1527-13 or its equivalent (including associated raw data, if requested by Company). Seller shall notify Company promptly (i) if (and to what extent) any Environmental Contamination on the Site will preclude or interfere with Seller's ability to perform its obligations under this PPA, and (ii) if applicable, Seller's plan for remediation thereof that would allow Seller to perform this PPA as and when due. The Phase I report delivered to Company under this paragraph shall be deemed Confidential Information for purposes of Section 20.18.



(B) Throughout the Term, Seller promptly shall:

1. disclose to Company any Environmental Contamination and, if required by law (including the requirements of any Permit), remediate (i) any Environmental Contamination identified at the Site caused by Seller, (ii) any preexisting Environmental Contamination at the Site discovered, impacted or exacerbated by Seller, or (iii) any Environmental Contamination at the Site that is otherwise the responsibility of Seller, *provided that*, Company acknowledges that Seller retains the right to choose the parcels within the Site to construct Wind Turbines and associated equipment;

2. if pursuant to a reasonable request, provide to Company copies of any further environmental assessments or investigations of the Site (including associated raw data); and

3. disclose to Company the existence of any enforcement, legal, or regulatory action or proceeding relating to any alleged presence of Environmental Contamination and/or the alleged violation of any Applicable Law related to the protection of endangered, migratory or other protected species.

(C) For purposes hereof:

1. “Environmental Contamination” means the introduction or presence of Hazardous Materials at such levels, quantities or location, or of such form or character, that (i) requires remediation under Applicable Law, (ii) present a material risk that the Site will not be available or usable for the purposes contemplated by this PPA, and/or (iii) will preclude or interfere with Seller’s ability to perform its obligations under this PPA as and when due.

2. “Hazardous Materials” means any substance, material, gas, or particulate matter that is regulated by any Governmental Authority as an environmental pollutant or dangerous to public health, public welfare, or the natural environment (including protection of non-human forms of life, land, water, groundwater, and air), including any material or substance that is (i) defined as “toxic,” “polluting,” “hazardous waste,” “hazardous material,” “hazardous substance,” “extremely hazardous waste,” “solid waste” or “restricted hazardous waste” under any provision of local, state, or federal law; (ii) petroleum, including any fraction, derivative or additive; (iii) asbestos; (iv) polychlorinated biphenyls; (v) radioactive material; (vi) designated as a “hazardous substance” pursuant to the Clean Water Act, 33 U.S.C. §1251 *et seq.* (33 U.S.C. §1251); (vii) defined as a “hazardous waste” pursuant to the Resource Conservation and Recovery Act, 42 U.S.C. §6901 *et seq.* (42 U.S.C. §6901); (viii) defined as a “hazardous substance” pursuant to the Comprehensive Environmental Response, Compensation, and Liability Act, 42 U.S.C. §9601 *et seq.* (42 U.S.C. §9601); (ix) defined as a “chemical substance” under the Toxic Substances Control Act, 15 U.S.C. §2601 *et seq.* (15 U.S.C. §2601); or (x) defined as a pesticide under the Federal Insecticide, Fungicide, and Rodenticide Act, 7 U.S.C. §136 *et seq.* (7 U.S.C. §136).

#### 4.3 Permits.

(A) Seller shall obtain and pay for all Permits necessary or advisable under Good Utility Practice for the construction, ownership, operation and maintenance of the Facility and the generation and delivery of the output from the Facility to Company. Seller shall keep Company reasonably informed as to the status of its permitting efforts. Seller shall promptly inform Company of (i) any Permits which Seller is unable to obtain, that are delayed, limited, suspended, terminated or otherwise constrained, along with a statement of whether and to what extent this circumstance may limit or preclude Seller's ability to perform under this PPA, and (ii) Seller's plan to overcome such issue(s) to allow Seller to perform this PPA as and when due. Company shall have the right to inspect and obtain copies of all Permits held by Seller.

(B) Seller represents and warrants to Company that, except for those Permits identified in Exhibit F - Seller's Needed Permits (each of which Seller anticipates will be obtained by Seller in the ordinary course of business), all Permits and other actions required by applicable Governmental Authorities to authorize Seller's execution, delivery and performance of this PPA have been duly obtained and are in full force and effect.

(C) Throughout the Term, Seller promptly shall disclose to Company the existence of any enforcement, legal, or regulatory action or proceeding relating to the alleged violation of any Permit held by Seller, which proceeding (if successful) could materially interfere with Seller's performance of this PPA.

(D) For purposes hereof, "Permits" means all applicable construction, land use, air quality, emissions control, environmental, protected species, and other permits, licenses and approvals from any Governmental Authority for construction, ownership, operation and maintenance of the Facility and the generation and delivery of Renewable Energy therefrom.

4.4 Governmental Inspections. Seller shall notify Company (i) sufficiently in advance of any known upcoming significant inspections by any Governmental Authority relating to the Facility, to allow Company the opportunity to attend, and (ii) promptly after any unscheduled or impromptu inspection with a description of the nature and outcome of such inspection.

#### 4.5 Commercial Operation.

(A) Subject to a Permitted Extension, Seller shall cause COD to occur at the Facility no later than December 31, 2018 (the "Target COD"); *provided*, Company shall not be obligated to accept and establish a Commercial Operation Date earlier than October 2, 2018. Notwithstanding the foregoing, the Target COD may be extended for not more than:

1. 90 days on a day-for-day basis if Seller has used Commercially Reasonable Efforts (including Seller's timely filing of required documents and payment of all applicable fees) to obtain permits necessary for the

construction and operation of the Facility in accordance with this PPA but is unable to obtain such permits due to delays beyond Seller's reasonable control ("Permitting Delay"); or

2. 90 days on a day-for-day basis if Seller has used Commercially Reasonable Efforts (including Seller's timely filing of required documents and payment of all applicable fees) to have the Facility physically interconnected to the Transmission Authority's System and to complete all Seller's Interconnection Facilities needed, if any, in order to interconnect the Facility to the Transmission Authority's System, but fails to secure any necessary commitments from the Transmission Authority for such interconnection, related agreements and upgrades due to delays beyond Seller's reasonable control ("Transmission Delay", each of (1) and (2), a "Permitted Extension").

Seller shall provide notice to Company promptly upon Seller becoming aware of the facts or circumstances giving rise to a Permitted Extension. If Seller claims any one or more of the foregoing Permitted Extensions, such extensions cannot cumulatively exceed 90 days and all Permitted Extensions taken shall be concurrent, rather than cumulative, during any overlapping days.

(B) Seller shall notify Company of the date on which Seller believes the Facility has achieved Commercial Operation (a "COD Notice"). A COD Notice shall include all necessary supporting documentation of the satisfaction or occurrence of all COD Conditions. Company shall have 10 Business Days to review a COD Notice and raise any Commercially Reasonable objection to Seller's satisfaction of any of the COD Conditions, *provided, however*, that Seller's COD Notice shall be deemed accepted by Company if Company fails to object within such time period. Seller may notify Company of completion of one or more COD Conditions on an individual and incremental basis prior to COD, *provided, however*, that Company shall in all cases have up to 10 Business Days to review and object to each such notice.

(C) For purposes hereof:

1. the "Commercial Operation Date" or "COD" means 12:01 am on the Day following the date on which Company receives Seller's COD Notice, without valid objection thereto by Company; and

2. the "COD Conditions" are:

(a) an officer of Seller, authorized to bind Seller and who is familiar with the Facility, has provided written confirmation that (1) all necessary and material Permits have been obtained and are in full force and effect, (2) Seller is in compliance with this PPA in all material respects, (3) Seller has made all necessary arrangements to obtain and pay the Local Provider for House Power, and (4) the Facility is available to commence normal operations in accordance with Seller's Interconnection Agreement, operating agreements, Construction Contracts, and applicable manufacturers' warranties;

(b) Seller has proven to Company's reasonable satisfaction that (1) Seller and the Transmission Authority have executed the Interconnection Agreement, and Seller is in compliance with all requirements of the Interconnection Agreement and has received no notice of breach thereof from the Transmission Authority, (2) the Facility is interconnected to the Transmission Authority's System, has been fully tested, has achieved initial synchronization, and has been successfully operated at a generation level acceptable to the Transmission Authority, without experiencing any abnormal or unsafe operating conditions on any interconnected system, and (3) Seller has made all other arrangements necessary to deliver Renewable Energy from the Facility to the Point of Delivery during the Term;

(c) Seller has obtained and provided to Company an independent registered professional engineer's certification stating that the Facility has been completed in all material respects, except for "punch list" items that do not have a Material Adverse Effect on the ability of the Facility to operate for its intended purpose;

(d) Seller has demonstrated the reliability of the Facility's communications systems and AGC interface with Company's EMCC, and the capability of the Facility to receive and respond to signals from Company's SCADA System; and

(e) Wind Turbines comprising at least 95% of the Nameplate Capacity planned for the Facility, and associated equipment sufficient to allow such Wind Turbines to generate and deliver Renewable Energy to the Point of Delivery, have been installed and are operational.

(D) For purposes hereof, the first "Commercial Operation Year" shall mean the period starting at 12:01 a.m. on the Commercial Operation Date and ending at 11:59 pm on the last Day of the calendar month in which the first anniversary of COD occurs, and each successive "Commercial Operation Year" shall mean the 12 month period following the prior Commercial Operation Year.

#### 4.6 Test Energy.

(A) Seller shall provide Company and Transmission Authority with the information necessary to have the Facility registered with the Transmission Authority for inclusion in any generation modeling maintained by the Transmission Authority, sufficiently in advance to allow the Facility to be registered in such model at least four months prior to generating any Test Energy. Company shall cooperate reasonably under this PPA to assist in the registration of the Facility to allow generation of Test Energy, *provided, however*, that Company shall not be obligated to undertake any obligations or duties performed by the Transmission Authority in the normal course of business.

(B) Seller shall coordinate the production and delivery of Test Energy with Company, with not less than five Business Days' prior Notice, or such other Commercially Reasonable prior Notice as Company may reasonably request.

(C) For purposes hereof, “Test Energy” means Renewable Energy generated by the Facility prior to COD, required to satisfy the COD Conditions.

## **Article 5 - Delivery**

### **5.1 Arrangements.**

(A) Seller shall be responsible for arranging, maintaining and paying the costs associated with the interconnection of the Facility to the Transmission Authority’s System. Seller shall comply with the Transmission Authority’s requirements for interconnection and shall comply with all requirements set forth in the applicable Transmission Tariff. The interconnection applications shall request that the Transmission Authority study the Phase I and Phase II components separately for Energy Resource Interconnection Service under the Transmission Tariff. The resulting Interconnection Agreement shall include the Nameplate Capacity in Energy Resource Interconnection Service.

(B) Seller hereby authorizes Company to contact, discuss and obtain information concerning both the Phase I and Phase II components of the Facility and the associated Interconnection Facilities directly with/from the Transmission Authority. Promptly upon request by Company, Seller shall confirm such authorization in writing to the Transmission Authority and any applicable transmission owners in such form as may be requested by Company or the Transmission Authority.

(C) To the extent applicable, Company shall be the market participant for the Facility, as defined by the Transmission Authority.

(D) Seller shall be responsible for all interconnection, electric losses, transmission and ancillary service arrangements and costs required to deliver Renewable Energy from the Facility to the Point of Delivery. Company shall be responsible for all electric losses, transmission and ancillary service arrangements and costs required to transmit and deliver Renewable Energy beyond the Point of Delivery.

### **5.2 Market Changes.**

(A) If at any time during the Term, the Transmission Authority changes, or the facilities at the Point of Delivery cease to be subject to, the Transmission Tariff, the Parties shall, and Seller shall cooperate in good faith to facilitate the delivery of Renewable Energy from the Point of Delivery to Company’s load, while attempting to preserve to the maximum extent possible, and at the lowest reasonable cost, the benefits, burdens and obligations set forth in this PPA as of the Effective Date.

(B) If and to the extent that changes to the rules of the Market Operator require Company to change the manner in which Company schedules and dispatches the Facility, the Parties shall, and Seller shall cooperate in good faith to change their protocols for operation of the Facility accordingly, while attempting to preserve to the

maximum extent possible, and at the lowest reasonable cost, the benefits, burdens and obligations set forth in this PPA as of the Effective Date.

(C) In the event Seller incurs costs, fees and expenses in making improvements to the Facility necessary to comply with this Section 5.2 ("Compliance Expenditures") and such Compliance Expenditures must be capitalized by Seller under generally accepted accounting principles consistently applied, then Company shall reimburse Seller for such Compliance Expenditures at a rate equal to one percent (1%) of such Compliance Expenditures per month, commencing on the first month following substantial completion of such improvements and ending upon the 100<sup>th</sup> month thereafter; *provided*, if there are less than 100 months remaining in the Term, then the one percent (1%) reimbursement percentage shall be adjusted appropriately to reflect the remainder of the Term.

### 5.3 Electric Metering Devices.

(A) All Electric Metering Devices used to measure energy shall be owned, installed, and maintained in accordance with the Interconnection Agreement, at no cost to Company.

1. Meter readings will be adjusted to reflect losses from the Electric Metering Devices to the Point of Delivery in accordance with applicable manufacturers' parameters or as otherwise agreed by the Parties.

2. Seller shall arrange any necessary authorization to provide Company access to all Electric Metering Devices for purposes related to this PPA, and shall provide Company the opportunity to be present at any time when such Electric Metering Devices are to be inspected, tested or adjusted.

(B) Either Party may elect to install and maintain, at its own expense, backup metering devices ("Back-Up Metering"), *provided, however*, that the specifications, installation and testing of any such Back-Up Metering shall be consistent with the requirements for the Electric Metering Devices. Upon written request from the other Party, the installing Party shall test the Back-Up Metering. The actual cost of any such test shall be borne by the Party requesting the test, unless, upon such test, Back-Up Metering is inaccurate by more than one percent, in which case the cost of the retest shall be borne by the installing Party. If requested in writing, the installing Party shall provide copies of any inspection or testing reports to the requesting Party.

(C) If an Electric Metering Device or Back-Up Metering fails to register, or if the measurement is inaccurate by more than one percent, an adjustment shall be made correcting all measurements as follows:

1. If the Electric Metering Device is found to be defective or inaccurate, the Parties shall use Back-up Metering, if installed, to determine the amount of such inaccuracy, *provided, however*, that Back-Up Metering has been tested and maintained and adjusted for losses on the same basis as the Electric Metering Device. If Back-Up Metering is not installed, or Back-Up Metering is also

found to be inaccurate by more than one percent, the Parties shall use the best available information for the period of inaccuracy, adjusted for losses to the Point of Delivery in accordance with applicable manufacturers' parameters or as otherwise agreed by the Parties.

2. If the Parties cannot agree on the actual period during which inaccurate measurements were made, the period shall be the shorter of (i) the last one-half of the period from the last previous test of the Electric Metering Device to the test that found the Electric Metering Device to be defective or inaccurate, or (ii) 180 Days immediately preceding the test that found the Electric Metering Device to be defective or inaccurate.

3. To the extent that an adjustment period covers a period of deliveries for which payment has already been made by Company, Company shall use the corrected measurements as determined in accordance with this Article 5 to re-compute the amount due for the period of the inaccuracy and shall subtract the previous payments made by Company for this period from such re-computed amount. The net difference shall be reflected as an adjustment on the next regular invoice in accordance with Article 9.

## **Article 6 - Conditions Precedent**

### **6.1 State Regulatory Approval.**

(A) No later than 45 Days after the date of this PPA, Company may apply to the State Regulatory Agency for State Regulatory Approval. If Company fails to apply for State Regulatory Approval within 45 Days following the date of this PPA, Company shall be deemed to have waived its right to obtain State Regulatory Approval and to terminate this PPA under this Section 6.1, and this PPA shall remain in full force and effect thereafter.

(B) If Company applies for State Regulatory Approval, Company shall use Commercially Reasonable Efforts to obtain State Regulatory Approval as soon as reasonably practicable. Seller shall cooperate reasonably with Company's efforts to obtain State Regulatory Approval.

(C) If Company applies for State Regulatory Approval, Company shall have the right to terminate this PPA, without any further financial or other obligation to Seller as a result of such termination, by notice to Seller:

1. at any time within 30 Days following issuance of a written order by the State Regulatory Agency rejecting State Regulatory Approval, or granting State Regulatory Approval with conditions unacceptable to Company in its sole discretion; or

2. at any time between the 240<sup>th</sup> and 270<sup>th</sup> Day following Company's application for State Regulatory Approval, if prior to the date of such

termination the State Regulatory Agency has not issued a written order granting or rejecting State Regulatory Approval.

If Company is eligible but fails to terminate this PPA by the applicable date, Company shall be deemed to have waived its right to terminate this PPA under this Section 6.1(C), and this PPA shall remain in full force and effect thereafter.

6.2 Related Transaction CPs. The Parties acknowledge and agree that they (or their Affiliates) are negotiating a purchase and sale agreement along with other definitive agreements (collectively the “PSA”) for the transfer by an Affiliate of Seller (the “PSA Seller”) to Company of a separate, approximately 478 MW wind farm located in Hale County, Texas, known as the Hale Wind Project (the “Hale Project”). As such, (A) either Party will have the right, but not the obligation, to terminate this PPA by Notice to the other Party within 10 Business Days following (i) the failure of the Company and PSA Seller to execute the PSA on or before June 30, 2017; (ii) the failure by Company to obtain, pursuant to the terms of the PSA, the Buyer’s Regulatory Approvals (as such term is defined in the PSA); and (B) if Closing (as defined in the PSA) does not occur pursuant to the PSA, then Company will have the right, but not the obligation, to terminate this PPA by Notice to Seller within 10 Business Days following the termination of the PSA; *provided*, such termination is pursuant solely to Section 2.8(a)(ii)(A) of the PSA (Bankruptcy Event), Section 2.8(a)(ix) of the PSA (Update), or Section 2.8(a)(xv) of the PSA (material breach). Such termination, as specified in subpart (A) and (B) above being the terminating Party’s sole and exclusive remedy as a result of the termination of this PPA pursuant to this Section 6.2. Company shall provide Seller written notice if and when the Buyer’s Regulatory Approvals have been obtained and the Closing has occurred.

6.3 Seller CPs. Either Party shall have the right to terminate this PPA, without any further financial or other obligation to the other as a result of such termination, by Notice to the other Party within fourteen (14) Days following the failure of Seller to (i) obtain approvals of Seller’s management and board of directors (or equivalent governing body) required for the performance of this Agreement on or before April 30, 2017, and (ii) to cause and Transmission Authority to execute the Interconnection Agreement on or before February 1, 2018. If either Party is eligible but fails to terminate this PPA by the applicable date, then such Party shall be deemed to have waived its right to terminate this PPA under this Section 6.3, and this PPA shall remain in full force and effect thereafter.



## Article 7 - Sale and Purchase

### 7.1 General Obligation.

(A) Beginning on the Commercial Operation Date, Seller shall generate from the Facility, deliver to the Point of Delivery, and sell to Company, and Company shall receive and purchase at the Point of Delivery, the Renewable Energy and other products and services required by this PPA. Seller shall not curtail or interrupt deliveries of Renewable Energy to Company for economic reasons of any type; *provided, however, that* (i) Seller's obligation to generate, deliver and sell to Company the products and services required hereunder shall be excused during Seller Excuse Hours, and (ii) Seller shall be permitted to curtail or interrupt that curtailed energy provided for in Section 8.3.

(B) Title and risk of loss of the products and services transacted by this PPA shall transfer from Seller to Company at the Point of Delivery.

7.2 AGC. Beginning on the Commercial Operation Date, Company shall dispatch the Facility through the EMCC AGC system. Seller shall ensure that, throughout the Term:

(A) the SCADA signal is capable of functioning on all AGC Set Points within the margin of error specified in the manufacturer's energy set point margin of error; and

(B) the Facility AGC Remote/Local status is in "Remote" set-point control during normal operations.

7.3 Green Benefits. The Parties acknowledge that existing and future Applicable Laws create value in the ownership, use or allocation of RECs. The Parties acknowledge that Company is not purchasing the RECs associated with the Renewable Energy or Test Energy purchased hereunder. Seller hereby grants Company the option to commence purchasing all of the RECs associated with the Renewable Energy on a prospective basis (the "REC Option"). Company may exercise its REC Option by providing Seller with 12-months prior written Notice of its intent to begin purchasing the RECs for the remainder of the Term. Seller shall be compensated for such RECs at a rate of \$1.05 per REC. Notwithstanding the foregoing, if at any time during the Term, Seller, or an Affiliate of Seller, originates a long term transaction (i.e., of a one year or greater duration) for the sale of RECs attributable to the Facility with an unaffiliated third party, by notice to Company (a "REC Notice"), Seller first shall offer to sell the RECs to Company on the same terms (the "REC ROFO"). The REC Notice shall identify (i) the nature and terms of the transaction, and (ii) the minimum price which Seller is willing to accept to proceed with the contemplated third party transaction. All information disclosed to Company by Seller with respect to the ROFO shall be deemed Confidential Information subject to Section 20.18.

(A) Seller shall allow Company 20 Business Days after the REC Notice to consider a proposed transaction. Within such period, Company shall either

(i) exercise its REC ROFO on substantially comparable terms to the proposed transaction or (ii) waive its REC ROFO (and its REC Option) with respect to, and for the duration of, that transaction. If Company fails to respond to a ROFO Notice within such 20 Business Day period, Company shall be deemed to have waived its ROFO right with respect to that transaction.

(B) If Company exercises its REC ROFO, the Parties shall have an additional 20 Business Day period to sign definitive agreements on terms no less favorable to Company than those contained in the REC ROFO Notice.

(C) If Company does not exercise its REC ROFO, Seller shall have the right to close its proposed transaction with the identified prospective buyer, *provided, however, that* such transaction shall have a purchase price of not less than the minimum price set forth in the REC ROFO Notice and the transaction shall have been closed not more than 30 Business Days following expiration of the Company's right to exercise its REC ROFO.

#### 7.4 Ancillary Services.

(A) Company shall be entitled to, and Seller shall make available to Company all Ancillary Services associated with the Facility, at no additional charge to Company. Seller shall use Commercially Reasonable Efforts to maximize the Ancillary Services available from the Facility, *provided, however, that* Seller shall be required to make any material capital expenditures or incur any significant increased operating expenses in connection with such efforts.

(B) Any compensation Seller receives under the Interconnection Agreement or otherwise from third parties for Ancillary Services shall be provided to Company at no additional cost to Company under this PPA. To implement the foregoing, Seller shall credit Company, as a reduction to Seller's monthly invoice or other mutually-agreed mechanism, for any compensation that Seller receives from third parties for Ancillary Services; *provided, that* if a Governmental Authority or Transmission Authority implements new or revised requirements for generators to create, modify, or supply Ancillary Services, requiring Seller to install additional equipment after the date hereof to meet such requirements, then Seller shall be allowed to reduce the amount to be credited to Company for Ancillary Services by an amount sufficient to recover the cost of such additional equipment. Any cost not so recovered by Seller in any billing period shall be carried forward as a reduction of the amount of the credit in subsequent billing periods.

(C) For purposes hereof, "Ancillary Services" means ancillary services addressed under the Transmission Tariff from time to time (if any), which are associated, directly or indirectly, with the capacity of the Facility or the generation and/or transmission of Renewable Energy from the Facility from time to time, including any rights to compensation therefor. By way of example only, "Ancillary Services" may include capacity or reliability attributes, resource adequacy characteristics, locational benefit attributes, and/or VaR generation.

## Article 8 - Payment Calculations

### 8.1 Payment for Renewable Energy.

(A) Company shall pay Seller a payment rate equal to 70% of the Energy Payment Rate for the first Commercial Operation Year, for all Test Energy delivered to Company.

(B) Commencing on the Commercial Operation Date, Company shall pay the Energy Payment Rate to Seller for all Renewable Energy delivered to the Point of Delivery; *provided* that Company shall never be required to pay for net instantaneous output of the Facility (as measured at the Point of Delivery) in excess of the Nameplate Capacity.

(C) The Energy Payment Rate shall be deemed Confidential Information for purposes of Section 20.18 below.

### 8.2 Reserved.

### 8.3 Curtailment.

(A) Company, or Transmission Authority, may require Seller, by telephonic communication or through use of the AGC Set Point to curtail the delivery of Renewable Energy to Company from the Facility, for any reason and in their sole discretion. Seller shall promptly comply with each such notification.

(B) For purposes hereof:

1. "Compensable Curtailment" means a curtailment of generation or delivery of Renewable Energy following COD arising out of the following (and only the following):

(a) a curtailment of the Facility by Company under Section 8.3(A); and

(b) Company's scheduling and other market participation activities, including (A) any energy offer made by Company with respect to the Facility, or (B) negative nodal/LMP pricing that results in Company's curtailment of the facility under Section 8.3(A).

(c) an election by Company to utilize non-firm transmission service to transmit Renewable Energy from the Point of Delivery to its load, and such non-firm transmission service is restricted or reduced by the applicable transmission service provider, except as provided in paragraph 2(c) below.

2. "Non-Compensable Curtailment" means any curtailment of the output of the Facility other than a Compensable Curtailment. By way of example only, Non-Compensable Curtailments include curtailments of generation or delivery of Renewable Energy arising out of:

(a) any action by the Transmission Authority, including any declaration of an Emergency Condition or Force Majeure under and as defined in the Interconnection Agreement;

(b) the restriction or reduction of maximum permissible output related to the Facility's Interconnection Agreement(s) including any operating limits imposed by the Transmission Authority;

(c) the restriction or reduction of non-firm transmission service by the applicable transmission service provider to the extent such restriction or reduction would also have been imposed even if firm transmission service had been in place;

(d) planned or unplanned maintenance outages on any part of the transmission system or any testing of the transmission system, only to the extent that such maintenance outages or testing of the transmission system results in a curtailment of the output of the Facility;

(e) the lack of available transmission from the Facility to the Point of Delivery;

(f) Seller's failure to maintain in full force and effect any Permit to own, operate and/or maintain the Facility;

(g) a civil, regulatory or criminal proceeding for the protection of endangered, migratory or other protected species; and

(h) Seller's failure to abide by the AGC Protocols, or a failure of the Facility to respond to AGC instructions from the EMCC.

3. "Compensable Curtailment Energy" means, for any period, when the AGC Set Point is below the Potential Energy, the MWh represented by the Potential Energy less the Renewable Energy actually generated (if any), during such period. For purposes of determining Compensable Curtailment Energy, the amount of Potential Energy at any given time shall be calculated using the best-available data and methods to determine an accurate representation of the amount of curtailed Renewable Energy:

(a) To the extent available, the Parties shall use Seller's real time Park Potential communicated to Company through the SCADA System as the proxy for Potential Energy, except to the extent that Park Potential is demonstrated not to accurately reflect the Potential Energy (plus or minus 2% average error for non-curtailment periods where generation exceeds 50% of nameplate capacity during one month).

(b) During those periods of time when the Park Potential is unavailable or does not accurately represent Potential Energy, the Parties shall use the best available data obtained through Commercially Reasonable methods to determine the Potential Energy.

4. “Tax Benefits” means an amount equal to (a) the PTCs to which Seller would have been entitled with respect to Renewable Energy that could have been delivered but for a Compensated Curtailment pursuant to Section 8.3(B), *plus* (b) a “gross up” amount to take into account the federal, state and local income tax to Seller on such payments in lieu of PTCs so that the net amount retained by Seller, after payment of federal, state and local income taxes, is equal to the amount set forth in subpart (a) of this definition. The calculation of such “gross up” amount shall be made on the assumption that the Seller is subject to federal income taxation, and state and local taxation with respect to amounts described in this Section 8.3(B)(4), at the highest applicable statutory rate applicable to corporations for the relevant period or periods, and shall take into account the deductibility (for federal income tax purposes) of applicable state and local taxes.

5. In administering curtailments in accordance with this Section 8.3, the Parties shall utilize the Curtailment Administration Protocols set forth in Exhibit L – Curtailment Administration Protocols of this PPA, provided, however, that any conflict between this Section 8.3 and Exhibit L shall be resolved in favor of this Section 8.3.

(C) No payment shall be due to Seller from Company for Renewable Energy curtailed as a consequence of any Non-Compensable Curtailment, or for Compensable Curtailment Energy prior to COD.

(D) For all Compensable Curtailments following COD, Company shall pay to Seller (i) all amounts that Seller would have received from Company under this PPA had the resulting Compensable Curtailment Energy actually been delivered, *plus* (ii) the amount of any associated Tax Benefits to which Seller would have been entitled but did not receive as a result, on a grossed-up basis, assuming that Seller has elected to receive PTCs. For the avoidance of doubt, Seller shall not be entitled to recover any Tax Benefits to the extent Seller would not have been entitled to receive PTCs had the Compensable Curtailment Energy actually been delivered.

## **Article 9 - Billing and Payment**

### **9.1 Billing.**

(A) The billing period under this PPA shall be the calendar month.

(B) As soon as practicable and in any event within 10 Days after the end of each month, Company shall provide to Seller a statement containing Company’s calculation of the amount due to Seller for such month, including the applicable billing parameters based upon Company’s reading of the Electric Metering Devices consistent with Section 5.2.

(C) No later than 15 Business Days following receipt of Company’s billing statement, Seller shall submit an invoice to Company in a form and by a method to be agreed by the Parties, showing the amount due Seller for the relevant month, specifying the products and services provided, all billing parameters, rates and factors,

and any other data relevant to the calculation of payments due to Seller. Such invoice shall include an explanation of any items in dispute, as well as all supporting documentation upon which Seller relies.

9.2 Payment. All payments shall be remitted via check or electronic funds transfer, as designated by the owed Party, on or before the 15<sup>th</sup> Business Day following receipt of the invoice. Remittances received by mail will be considered to have been paid when due if the postmark indicates the payment was mailed on or before the 15<sup>th</sup> Business Day following receipt of the billing invoice.

(A) If a payment is late, a late payment charge shall be applied to the unpaid balance for the number of days payment was late and shall be added to the next billing statement. Late payment charges shall include interest calculated using the prime rate of interest as published on the date of the invoice in *The Wall Street Journal* (or, if unavailable, an equivalent publication on or about that date).

(B) Company at any time may offset against amounts owed to Seller, any liquidated amounts, accrued damages and other payments, and undisputed billing errors and adjustments, which are owed by Seller to Company.

(C) Seller and Company may and shall net their obligations to each other under this PPA, and payment of the net amount shall discharge all mutual undisputed obligations between the Parties.

9.3 Billing Disputes. Either Party may dispute invoiced amounts pursuant to Section 13.1, but shall pay to the other Party at least the portion of invoiced amounts that is not disputed, on or before the invoice due date. When the billing dispute is resolved, the owing Party shall pay the amount owed within five (5) Business Days of the date of such resolution, with late payment interest charges calculated on the amount owed in accordance with Section 9.2(A).

## **Article 10 - Operations and Maintenance**

### **10.1 Operation and Administration**

(A) Seller shall staff, control, and operate the Facility consistent with Good Utility Practices, Exhibit I – AGC Protocols; Data Collection; Technical Specifications and this PPA. Seller shall cause personnel to be available 24x7 via telephone or other electronic means with (i) the capability of remotely starting, operating and stopping the Facility within 10 minutes, and (ii) the ability to be present at the Site within 60 minutes.

(B) Seller shall comply with Good Utility Practices, the requirements of all Governmental Authorities and all reasonable requirements of Company in the operation of the Facility. By way of example only, Seller shall perform all capacity testing of the Facility and related reporting, as and when required by Governmental Authorities.

(C) Seller shall provide to Company a day-ahead availability forecast in accordance with Exhibit I - AGC Protocols; Data Collection; Technical Specifications and any other reporting requirements required for compliance with NERC reliability standards. Company shall forward Seller's forecast to the applicable local reliability coordinator on Seller's behalf, *provided, however*, that Seller shall remain responsible to ensure the timeliness and accuracy of forecasts and any changes to the real-time or forecast availability of the Facility. If and to the extent that the ERO modifies the forecasting or other reporting requirements imposed on Company or the Facility, Seller shall timely provide required data to Company or the ERO, as applicable.

#### 10.2 Facility Maintenance.

(A) Seller shall maintain the Facility in accordance with Good Utility Practice. Seller shall coordinate its regular maintenance requirements for the Facility with Company ("Maintenance Schedules"). Maintenance Schedules shall be provided to Company in writing and sufficiently in advance for Commercially Reasonable review, and Company may, within ten (10) days after receipt of the schedule, request reasonable modifications to the Maintenance Schedule. Seller shall be permitted to reduce deliveries of Renewable Energy and cease operation of the entire Facility or individual units, if applicable, during any period of Facility maintenance.

(B) Seller shall coordinate with Company and the Transmission Authority the timing and duration of planned outages.

(C) When Forced Outages occur, Seller shall notify Company's EMCC of the existence, nature, start time, and expected duration of the Forced Outage as soon as practical, but in no event later than one hour after the Forced Outage occurs. Seller shall immediately inform Company's EMCC of changes in the expected duration of the Forced Outage except to the extent relieved of this obligation by Company's EMCC with respect thereto.

#### 10.3 Books and Records.

(A) Seller shall maintain an accurate and up-to-date operating log at the Facility, in electronic format, with records of production for each clock hour; changes in operating status; Forced Outages; information required by Governmental Authorities in the prescribed format; and other information reasonably requested by Company.

(B) Seller and Company shall each keep complete and accurate records and all other data required by each of them for the purposes of proper administration of this PPA, including metering, billing and payment records, and such records as may be required by Governmental Authorities. Originals or copies of all Operating Records shall be maintained at Seller's Juno Beach, Florida facility or such other mutually-agreeable location. Company may examine and make copies of such Operating Records from time to time upon request, during normal business hours.

10.4 Access to Facility. Representatives of Company shall have access to the Facility from time to time, on Commercially Reasonable prior notice, to read meters,

perform inspections and take such other actions as may be appropriate to facilitate Company's performance of this PPA. While at the Facility, such representatives shall observe Seller's safety precautions and shall conduct themselves in a manner that will not interfere with operation of the Facility.

#### 10.5 Real Time Data.

(A) Seller shall communicate all data necessary for Company to integrate the Facility into Company's EMCC in real time through the Facility's SCADA System in accordance with Exhibit I - AGC Protocols; Data Collection; Technical Specifications. Seller shall maintain the Facility's SCADA System so that it is capable of interfacing with and reacting to Company's AGC Set-Point and responding to signals from the Company's EMCC in accordance with the AGC Protocols.

(B) Seller shall use Commercially Reasonable Efforts to adjust the real time Park Potential of the Facility when Company communicates to Seller a measured difference of plus or minus two percent between the metered Renewable Energy and Park Potential, during periods when generation is not curtailed.

(C) From and after the Commercial Operation Date, Seller provide Company, at Seller's expense, real time performance and meteorological data for all Wind Turbines and wind energy-standard remote sensing technologies at the Facility in accordance with Exhibit I - AGC Protocols; Data Collection; Technical Specifications for the Term of this PPA. Seller shall maintain data collection systems that are compatible with Company's PI System. Seller shall ensure that real time communications capabilities are available and maintained for transmission to Company's PI System. Seller shall ensure that all meteorological equipment at a minimum meets the specifications set forth in Exhibit I - AGC Protocols; Data Collection; Technical Specifications. Company shall have the right to disclose data gathered through the Company's PI System publicly; *provided, however*, that such data is (i) masked to obscure the origin of the data and (ii) aggregated so that the data cannot be correlated and used by competitors of Seller and/or the supplier of the Wind Turbines.

10.6 Accreditation. Seller shall perform at Seller's expense, any reporting and testing of the Facility required by Governmental Authorities in a manner to permit accreditation of the Facility and qualification as a Capacity Resource.

#### 10.7 Operating Committee and Operating Procedures.

(A) Company and Seller shall each appoint one representative and one alternate representative to act as the Operating Committee in matters relating to the Parties' performance obligations under this PPA and to develop operating arrangements for the generation, delivery and receipt of Renewable Energy from the Facility. The Parties' initial representatives on the Operating Committee are set forth in Exhibit D - Notices.

(B) The Operating Committee may develop mutually agreeable written Operating Procedures consistent with the requirements of this PPA, to address matters



such as day-to-day communications; key personnel; operations-center interface; metering, telemetering, telecommunications, and data acquisition procedures; operations and maintenance scheduling and reporting; reports; operations log; testing procedures; and such other matters as may be mutually agreed upon by the Operating Committee.

(C) The Operating Committee shall review the requirements for AGC and Data Collection from time to time after the date hereof and may agree on modifications thereto to the extent necessary or convenient for operation of the Facility in accordance with this PPA.

(D) The Operating Committee shall have authority to act in all technical and day-to-day operational matters relating to performance of this PPA and to attempt to resolve potential disputes, *provided, however*, that except as explicitly provided herein, the Operating Committee shall have no authority to amend or waive any provision of this PPA.

## **Article 11 - Security for Performance**

### **11.1 Security Fund.**

(A) During the Term of this PPA, Seller shall fund and maintain security in favor of Company, at Seller's expense, to secure Seller's obligations to Company under this PPA (the "Security Fund"), in accordance with this Article 11.

Seller shall establish and fund the initial Security Fund in the amount of [REDACTED] no later than 30 Days following execution of this Agreement. Within 5 Business Days following Company's receipt of State Regulatory Approval, the amount of the Security Fund shall be increased to [REDACTED]. Within 5 Business Days following COD, the amount of the Security Fund shall be reduced to [REDACTED], which amount shall remain in place for the Term.

(B) Company may draw from the Security Fund such amounts as are necessary to recover amounts owing to Company pursuant to this PPA, including any Liquidated Delay Damages, Actual Damages, liquidated damages for failure to achieve COD, and any amounts for which Company is entitled to indemnification under this PPA. Company may, in its sole discretion, draw all or any part of such amounts from any form of security to the extent available pursuant to this Article 11 and in any sequence Company may select. Company's failure or delay to draw any amount from the Security Fund in any instance shall not prejudice Company's rights to subsequently recover such amount from the Security Fund or in any other manner.

(C) Company shall notify Seller within 5 Business Days following any draw on the Security Fund by Company, including the amount thereof and the basis therefor.

11.2 Replenishment. Seller shall replenish the Security Fund to the applicable levels set forth in Section 11.1(B) within 15 Business Days after Company makes a

draw on the Security Fund; *provided*, following COD such replenishment shall not exceed the amount remaining under the Damage Cap (as provided in Section 12.4(A)). Notwithstanding the foregoing, within 15 Business Days after Company makes a draw on the Security Fund associated with the damages described in Section 12.4(B), Seller shall replenish all amounts drawn from the Security Fund.

### 11.3 Form.

(A) The Security Fund may be in the form of an irrevocable standby letter of credit substantially in the form of Exhibit G – Form of Letter of Credit (a “Letter of Credit”) from a financial institution reasonably acceptable to Company (“Issuer”).

1. The Issuer of the Letter of Credit shall have and maintain a Credit Rating equivalent to A- (or better) by Standard & Poors and A3 (or better) from Moodys. If such Credit Rating is A- or A3, the Issuer must not be on credit watch by any rating agency.

2. The Letter of Credit must be for a minimum term of 360 Days. Seller shall give Company at least 30 Days advance notice prior to any expiration or earlier termination of the Letter of Credit. Seller shall cause the renewal or extension of the Letter of Credit for additional consecutive terms of 360 Days or more (or, if shorter, the remainder of the Term) more than 30 Days prior to each expiration date of the security. If the Letter of Credit is not renewed or extended at least 30 Days prior to its expiration date or otherwise is terminated early, Company shall have the right to draw immediately upon the Letter of Credit and to place the amounts so drawn, at Seller’s cost and with Seller’s funds, in an Escrow Account in accordance with paragraph (B) below, until and unless Seller provides a substitute form of security meeting the requirements of this Section 11.3.

(B) The Security Fund may be in the form of U.S. currency deposited into an escrow account with a state- or federally-chartered commercial bank with an office in the State of Minnesota, with net assets of at least \$1 billion (the “Escrow Account”).

1. The Escrow Account shall be governed by an escrow agreement in form mutually satisfactory to Seller, Company and the escrow agent, *provided* that (a) Company shall hold a first and exclusive perfected security interest in the funds in the Escrow Account, (b) Company shall be permitted unilaterally to draw down any amount therein, regardless of any protest by Seller or any other party liable thereon (*provided* that nothing in the Escrow Agreement shall preclude any protest against Company by Seller, following any draw, that such draw did not comply with this Agreement), and (c) Seller shall pay all fees and expenses of the escrow agent.

2. Funds held in the Escrow Account may be invested as Seller may direct in any of the following:

- a money-market fund sponsored by the escrow agent;

- U.S. treasury obligations with a maturity of 90 Days or less;
- commercial paper rated “A” or better, with a maturity of 90 days or less; and
- other liquid investment-grade investments with maturities of three months or less, approved by Company in advance (such approval not to be unreasonably withheld or delayed).

3. All investment income on the Escrow Account shall be taxable to, and accrue for the benefit of, Seller. After the Commercial Operation Date, periodic sweeps by Seller for recovery of interest earned by the escrowed funds shall be allowed, and, at any time the balance in the Escrow Account exceeds the required amount of security, the escrow agent may remit any excess to Seller.

(C) The Security Fund may consist of a guaranty substantially in the form of Exhibit G-2 (Guaranty), from an Issuer, parent or other guarantor (“Guarantor”) with a minimum net worth of \$250,000,000 and a senior unsecured credit rating (unenhanced by third-party support) equivalent to Investment Grade. If such senior unsecured credit rating of the Guarantor is exactly equivalent to Investment Grade, then the Guarantor must not be on credit watch or have a negative outlook by a rating agency. If the credit rating of the Guarantor is downgraded below Investment Grade or if there has been an event that has a Material Adverse Effect to the creditworthiness of the Guarantor (as determined reasonably by Company), then Seller shall be required to convert the guarantee provided by such Guarantor to a Security Fund instrument meeting the criteria set forth in either sub-paragraph (1) or sub-paragraph (2) above no later than 10 Business Days after receiving information from or about the Guarantor that the Guarantor no longer satisfies the requirements of this paragraph.

(D) Upon request by Seller, Company shall negotiate in good faith immaterial changes to Exhibit G – Form of Letter of Credit and/or Exhibit H – Form of Guaranty, *provided* that Seller shall pay or reimburse Company for the incremental direct expenses (including the fees and expenses of counsel) incurred by Company after the Effective Date in connection therewith.

(E) Seller may change the form of the Security Fund at any time and from time to time upon Commercially Reasonable prior notice to Company, *provided, however,* that the Security Fund must at all times satisfy the requirements of this Article 11.

11.4 Re-Evaluation. Company may reevaluate from time to time the value of any Security posted by Seller to determine, in a Commercially Reasonable manner, whether (i) it continues to satisfy the requirements in this PPA or (ii) there has been a change that has a Material Adverse Effect in the creditworthiness of the Issuer or guarantor, such that it does not satisfy, or with the passage of time it will no longer satisfy, requirements of this PPA. If Company determines, in a Commercially Reasonable manner, that there has been an event that has caused, or will cause with the passage of time, Seller’s Security to no longer satisfy the requirements of this PPA,

then Company shall provide prompt Notice to Seller of such event and after receipt of such Notice, Seller shall be required to provide alternative Security that satisfies the terms of this PPA.

11.5 Survival. The Security Fund shall survive termination of this PPA to be available to pay any amounts owed to Company arising prior to or upon termination. Promptly following (i) the end of the Term and the completion of all of Seller's obligations under this PPA, or (ii) termination of this PPA for any reason prior to the Scheduled Termination Date, Company shall determine reasonably the amount, if any, owed by Seller for any obligations or damages arising out of this PPA. Company may draw such amount and shall release the balance of the Security Fund (including any accumulated interest, if applicable) to Seller.

11.6 Expenses. Seller shall reimburse Company for its direct expenses (including the fees and expenses of counsel) incurred by Company after the Effective Date in connection with the preparation, negotiation, execution and/or release (including making a draw of funds) of the Security Fund under this Article 11.

## **Article 12 - Default and Remedies**

### **12.1 Default by Seller: General**

(A) Events. Any of the following events shall constitute a default by Seller under this PPA. If no cure period is provided below, such default shall be deemed an Event of Default by Seller immediately upon its occurrence. If a cure period is provided below, such default shall mature into an Event of Default if not cured within the indicated cure period, subject to Section 13.3 below.

1. Seller's application for, or consent (by admission of material allegations of a petition or otherwise) to, the appointment of a receiver, trustee or liquidator for Seller or for all or substantially all of its assets, or its authorization of such application or consent, or the commencement of any proceedings seeking such appointment without such authorization, consent or application, which proceedings continue undismissed or unstayed for a period of 60 Days from inception.

*Cure Period:* None.

2. Seller's authorization or filing of a voluntary petition in bankruptcy or application for or consent (by admission of material allegations of a petition or otherwise) to the application of any bankruptcy, reorganization, readjustment of debt, insolvency, dissolution, liquidation or other similar law of any jurisdiction or the institution of such proceedings against Seller without such authorization, application or consent, which proceedings remain undismissed or unstayed for 60 Days from its inception or which result in adjudication of bankruptcy or insolvency within such time.

*Cure Period:* None.

3. Seller's assignment of this PPA or the Facility, or any Change of Control, not permitted by Section 19.1.

*Cure Period:* None.

4. Any representation or warranty made by Seller in this PPA is false or misleading in any material respect when made or deemed made and such failure has a Material Adverse Effect on Seller's ability to perform this PPA.

*Cure Period:* 20 Business Days after Company provides notice of such breach; *provided*, if a change in law occurs during the term causes a representation or warranty made by Seller to be materially false or misleading, such breach of the representation or warranty shall not be an Event of Default if Seller has used Commercially Reasonable efforts to comply with such change in law in order to make the representation and warranty no longer false or misleading.

5. Seller's failure to establish and maintain the Security Fund as and in the amounts required under Article 11.

*Cure Period:* Five (5) Business Days after Company provides notice of Seller's failure.

6. Seller's failure to obtain and maintain insurance in scope and amounts required under Article 16.

*Cure Period:* 10 Business Days after Company provides notice of Seller's failure.

7. Seller's failure to make any payment to Company as and when required by this PPA, including Liquidated Delay Damages, Actual Damages, and any required indemnification.

*Cure Period:* 10 Business Days after the date Seller receives notice from Company that the amount is overdue.

8. Reserved.

9. A breach by Seller of the Interconnection Agreement, which breach materially interferes with Seller's delivery of Renewable Energy to the Point of Delivery, Company's ability to accept Renewable Energy at the Point of Delivery, Company's ability to transmit Renewable Energy beyond the Point of Delivery, and/or otherwise has a Material Adverse Effect on Company.

*Cure Period:* 30 Days from the breach or the cure period allowed by the Interconnection Agreement (whichever is longer).

10. Beginning with the second Commercial Operation Year, the failure of the Facility to achieve the Guaranteed Mechanical Availability Percentage (as determined pursuant to Exhibit M).

*Cure Period:* As provided for in Exhibit M.

11. The failure by Seller to perform or observe any other material obligation to Company under this PPA, unexcused by Force Majeure (other than failure to achieve COD, which is addressed in Section 12.2 below).

*Cure Period:* 30 Days after notice thereof shall have been given by Company; *provided*, that if such default is not reasonably capable of cure within such 30-Day period, Seller shall have such additional period of time (not to exceed 90 Days in any event) as is reasonably necessary for cure, so long as Seller initiates cure within such 30-Day period and diligently prosecutes the cure to conclusion thereafter.

(B) Remedies for Default. In connection with any default by Seller under this Section 12.1 (whether or not cured by Seller), Company may:

1. Seek Actual Damages in such amounts and on such basis for the default as authorized by this PPA;
2. Offset against any payments due to Seller, any Actual Damages and other amounts due from Seller; and/or
3. Draw any Actual Damages and other amounts due from Seller, from the Security Fund.

(C) Termination for Event of Default. Upon and at any time following an Event of Default by Seller under this Section 12.1, in addition to its rights under Section 12.1(B) above, Company may terminate this PPA immediately upon notice to Seller, without penalty or further obligation to Seller. In connection with any such termination, Company may collect from Seller (subject to the Damage Cap) all Actual Damages arising from such Event of Default through the Scheduled Termination Date.

(D) Specific Performance. In addition to the other remedies specified herein, upon any Event of Default of Seller under this Section 12.1, Company may elect to treat this PPA as being in full force and effect and Company shall have the right to specific performance.

(E)



12.2 Default by Seller: Failure to Achieve COD.

(A) COD Delay. Subject to a Permitted Extension, Seller shall be in default under this PPA if the Facility fails to achieve COD by the Target COD (“COD Delay”). Seller shall be liable to pay \$57,500 per Day (“Liquidated Delay Damages”) to Company as a liquidated damage and not a penalty, in lieu of Actual Damages, for any COD Delay. Except as provided in Section 12.2(C) below, the payment of Liquidated Delay Damages shall be Company’s sole and exclusive remedy for a COD Delay. Liquidated Delay Damages shall begin to accrue on the Day after the Target COD (as it may be extended due to Force Majeure or a Permitted Extension) until the first to occur of COD or termination of this PPA pursuant to Section 12.2(C) below.

(B) Cure. Subject to a Permitted Extension, Seller shall have a cure period of 45 days for its failure to achieve Commercial Operation by the Target COD, *provided, however,* that if during such period Seller provides a written opinion from a mutually-agreeable independent engineer that COD can reasonably be achieved within an additional 45 Day period, then the cure period shall be 90 Days after the Target COD to achieve Commercial Operation. The payment of accrued Liquidated Delay Damages shall be a condition to any such cure.

(C) Termination. Failure to cure a COD Delay within the applicable cure period set forth in Section 12.2(B) shall be an Event of Default by Seller. Upon such an Event of Default, Company may as its sole and exclusive remedy for a COD Event of Default (i) terminate this PPA immediately upon notice to Seller, without penalty or further obligation to Seller except as to costs and balances incurred prior to the effective date of such termination, and (ii) in connection therewith, in lieu of Actual Damages for the balance of the Term, collect from Seller liquidated damages therefor in the amount of [REDACTED] less the Liquidated Delay Damages paid by Seller to Company pursuant to Section 12.2(A).

12.3 Default by Company.

(A) Events. Any of the following events shall constitute a default by Company under this PPA. If no cure period is provided below, such default shall be deemed an Event of Default by Company immediately upon its occurrence. If a cure period is provided below, such default shall mature into an Event of Default if not cured within the indicated cure period, subject to Section 13.3 below.

1. Company’s application for, or consent (by admission of material allegations of a petition or otherwise) to, the appointment of a receiver, trustee or liquidator for Company or for all or substantially all of its assets, or its authorization of such application or consent, or the commencement of any proceedings seeking such appointment without such authorization, consent or

application, which proceedings continue undismissed or unstayed for a period of 60 Days from inception.

*Cure Period:* None.

2. Company's authorization or filing of a voluntary petition in bankruptcy or application for or consent (by admission of material allegations of a petition or otherwise) to the application of any bankruptcy, reorganization, readjustment of debt, insolvency, dissolution, liquidation or other similar law of any jurisdiction or the institution of such proceedings against Company without such authorization, application or consent, which proceedings remain undismissed or unstayed for 60 Days from its inception or which result in adjudication of bankruptcy or insolvency within such time.

*Cure Period:* None.

3. Company's assignment of this PPA not permitted by Section 19.2.

*Cure Period:* None.

4. Any representation or warranty made by Company in this PPA is false or misleading in any material respect when made or deemed made and such failure has a Material Adverse Effect on Company's ability to perform this PPA.

*Cure Period:* 20 Business Days after Seller provides notice of such breach; *provided*, if a change in law occurs during the term causes a representation or warranty made by Company to be materially false or misleading, such breach of the representation or warranty shall not be an Event of Default if Company has used commercially reasonable efforts to comply with such change in law in order to make the representation and warranty no longer false or misleading.

5. Any representation or warranty by Company in this PPA that has a Material Adverse Effect on Company's ability to perform this PPA is proven to have been false in any material respect when made.

*Cure Period:* None.

6. Company's failure to make any payment to Seller as and when required by this PPA, including invoiced amounts, Actual Damages and any required indemnification.

*Cure Period:* 10 Business Days after the date Company receives notice from Seller that the amount is overdue.

7. Reserved.



8. The failure by Company to perform or observe any other material obligation to Seller under this PPA, unexcused by Force Majeure.

*Cure Period:* 30 Days after notice thereof shall have been given by Seller; *provided*, that if such default is not reasonably capable of cure within such 30-Day period, Company shall have such additional period of time (not to exceed 120 Days in any event) as is reasonably necessary for cure, so long as Company initiates cure within such 30-Day period and diligently prosecutes the cure to conclusion thereafter.

(B) Remedies for Default. In connection with any default by Company (whether or not cured by Company), Seller may:

1. Seek Actual Damages in such amounts and on such basis for the default as authorized by this PPA; and/or
2. Offset against any payments due to Company, any Actual Damages and other amounts due from Company.

(C) Termination for Event of Default. Upon an Event of Default by Company, in addition to its rights under Section 12.3(B) above, Seller may terminate this PPA immediately upon notice to Company, without penalty or further obligation to Company, and in connection therewith, collect from Company all Actual Damages arising from such Event of Default through the Scheduled Termination Date.

(D) Specific Performance. In addition to the other remedies specified herein, upon any Event of Default of Company under this Section 12.3, Seller may elect to treat this PPA as being in full force and effect and Seller shall have the right to specific performance.

#### 12.4 Limitations on Damages.

(A) Except as otherwise provided in Section 12.4(B), Seller's aggregate financial liability to Company for Actual Damages following COD shall not exceed \$17,250,000 (the "Damage Cap"). If at any time following COD, Company incurs damages in excess of the Damage Cap that Seller does not pay when billed by Company, Company shall have the right to terminate this PPA upon notice to Seller, without further obligation by either Party except as to costs and balances incurred prior to the effective date of such termination.

(B) Actual Damages payable by Seller arising out of any of the following events shall not be subject to the Damage Cap and shall not be credited against the Damage Cap:

1. damage to Company-owned facilities proximately caused by negligence, breach of this PPA or other misconduct by Seller, its directors, officers, employees and agents;

2. Seller's intentional misrepresentation or intentional misconduct in connection with this PPA or the operation of the Facility;
3. the sale or diversion by Seller to a third party of any capacity or energy from the Facility, excluding any sales in mitigation of damages;
4. Seller's failure (i) to maintain insurance coverages in the types and amounts required by this PPA or (ii) to apply any insurance proceeds as required by Section 16.4;
5. any claim for indemnification under this PPA;
6. any Environmental Contamination caused by Seller; or
7. damages incurred by Company in connection with any bankruptcy or insolvency proceeding involving Seller, including Company's loss of the benefit of its bargain due to rejection or other termination of this PPA in such proceeding.

(C) The Parties confirm that the express remedies and measures of damages provided in this PPA satisfy the essential purposes hereof. If no remedy or measure of damages is expressly herein provided, the obligor's liability shall be limited to all direct damages proximately caused by such default ("Actual Damages") incurred by the non-defaulting Party, *provided* that if Seller is the defaulting Party, Actual Damages recoverable by Company hereunder may include Replacement Power Costs. **Neither Party shall be liable to the other Party for consequential, incidental, punitive, exemplary, special, treble, equitable or indirect damages, lost profits or other business interruption damages regardless of whether the relevant cause of action arises from statute, in tort or contract** (except to the extent expressly provided herein); *provided, however*, that if either Party is held liable to a third party for such damages and the Party held liable for such damages is entitled to indemnification from the other Party hereto, the indemnifying Party shall be liable for, and obligated to reimburse the indemnified Party for all such damages.

(D) To the extent damages required to be paid hereunder are liquidated, the Parties acknowledge that actual damages would be substantial but difficult or impossible to determine, that otherwise obtaining an adequate remedy is inconvenient, and that the liquidated damages constitute a reasonable approximation of the harm or loss.

(E) Notwithstanding any other provision of this Agreement to the contrary, in no circumstance shall Seller be entitled to an increase, or shall Company be entitled to a decrease, in the Energy Payment Rate under this PPA and neither Seller nor Buyer shall claim that any delay or other circumstance under this PPA entitles it to anything other than the applicable Energy Payment Rate set forth in this PPA.

## 12.5 Step-In Rights.

(A) Upon the occurrence of a default by Seller following COD that could be cured by Company's possession of the Facility, the Phase I and Phase II components of the Facility, as appropriate, Company shall have the right, but not the obligation, to assume control and operate the Facility, the Phase I and Phase II components of the Facility, as appropriate, as agent for Seller (whether voluntary or involuntary) in accordance with Seller's rights, obligations, and interest under this PPA ("Step-In Rights"). Company shall give Seller and the Facility Lender at least 10 Business Days' notice in advance of exercising Company's Step-In Rights. Exercise of Step-In Rights *per se* shall not be deemed to cure the associated default, and shall not preclude or limit Company's right to exercise its other remedies against Seller under this PPA.

(B) Seller irrevocably appoints Company as Seller's attorney-in-fact for the exclusive purpose of executing such documents and taking such other actions as Company may reasonably deem necessary, appropriate or prudent to implement its Step-In Rights.

(C) Company acknowledges that Company may be required and shall relinquish or delay exercise of its Step-In Rights in the event that the Facility Lender elects to appoint a receiver, foreclose and/or otherwise obtain possession of the Facility, the Phase I and Phase II components of the Facility, as appropriate, under the Financing Documents. Seller shall not grant any person, other than the Facility Lender, a right to possess, assume control of, or operate the Facility, the Phase I and Phase II components of the Facility in derogation of Company's Step-In Rights.

(D) Seller shall reimburse Company for its actual and documented expenses and costs (including the fees and expenses of counsel) incurred by Company in connection with exercising its Step-In Rights ("Step-In Costs").

(E) During the period of Company's exercise of its Step-In Rights:

1. Company shall implement its Step-In Rights and operate the Facility in conformance with Good Utility Practice.
2. Company shall perform Seller's obligations in a manner consistent with Seller's duties under this PPA.
3. Seller shall retain legal title to and ownership of the Facility.
4. Seller shall make available at the Facility, the Phase I and Phase II components of the Facility, as appropriate, all documents, contracts, books, manuals, reports, and records required for Company to construct, operate, and maintain the Facility, the Phase I and Phase II components of the Facility, as appropriate.

5. Seller shall give Company, its employees and contractors, unrestricted access to the Site and the Facility, Phase I and Phase II components of the Facility, as appropriate.

6. Seller shall cooperate in the implementation of Company's Step-In Rights.

7. Company shall devote the Renewable Energy generated and delivered from the Facility during such period towards satisfaction of Seller's obligations hereunder.

(F) During the period of Company's exercise of its Step-In Rights, Company shall purchase the Renewable Energy from the Facility as provided herein; *provided* that Company may withhold its Step-In Costs from payments due to Seller hereunder. In the event that net revenues due to Seller are insufficient to cover such Step-In Costs, Company may draw upon the Security Fund to cover such Step-In Costs.

(G) Company may relinquish its Step-In Rights at any time, on at least 15 Days' notice to Seller and the Facility Lender. Company shall relinquish its Step-In Rights on the earliest of (i) termination of this PPA, or (ii) Seller's (or the Facility Lender's) cure of the default that led to exercise of Company's Step-In Rights within the applicable cure period set forth herein.

(H) This Section 12.5 shall be specifically enforceable by Company, without bond and without the need to prove irreparable harm.

(I) Exercise of its Step-In Rights shall not constitute an assumption by Company of any liability of Seller.

12.6 Bankruptcy. This PPA grants each Party the contractual right to "cause the liquidation, termination or acceleration" of the transactions within the meaning of Sections 556, 560 and 561 of the U.S. Bankruptcy Code, as they may be amended superseded or replaced from time to time. Upon a bankruptcy, a non-defaulting Party shall be entitled to exercise its rights and remedies under this PPA in accordance with the safe harbor provisions of the Bankruptcy Code set forth in, *inter alia*, Sections 362(b)(6), 362(b)(17), 362(b)(27), 362(o), 546(e), 548(d)(2), 556, 560 and 561, as they may be amended, superseded or replaced from time to time

12.7 Cumulative Remedies. Except as explicitly provided to the contrary in this PPA, each right or remedy of the Parties provided for in this PPA shall be cumulative of and shall be in addition to every other right or remedy provided for in this PPA, and the exercise of one or more of the rights or remedies provided for herein shall not preclude the simultaneous or later exercise by such Party of any other rights or remedies provided for herein.

12.8 Duty to Mitigate. Each Party shall use Commercially Reasonable Efforts to mitigate any damages it may incur as a result of a default by the other Party under this PPA.

## Article 13 - Dispute Resolution

### 13.1 Negotiation.

(A) In the event of any dispute arising under or associated with the Parties' performance of this PPA (a "Dispute"), within 10 Business Days following notice by either Party (a "Dispute Notice"), (i) each Party shall appoint a representative, and (ii) the representatives shall meet, negotiate and attempt in good faith to resolve the Dispute quickly, informally and inexpensively.

(B) In the event the Parties' representatives cannot resolve the Dispute within 30 Business Days after the first meeting, either Party may request that consideration and resolution of the Dispute be transferred to senior management. Within 10 Business Days following such a request, each Party shall submit a written summary of the Dispute describing the issues and claims to a senior officer of each Party designated to address the Dispute. Within 10 Business Days after receipt of each Party's Dispute summaries, the designated senior managers for both Parties shall negotiate in good faith to resolve the Dispute. If such senior managers are unable to resolve the Dispute thereafter, either Party may seek available legal remedies, subject to Section 13.3.

13.2 Time Bar. If no Dispute Notice has been issued within 18 months following the occurrence of events or circumstances giving rise to the Dispute (regardless of the actual knowledge of either Party of such events and circumstances), all claims related to such Dispute (including any allegations of billing errors) shall be deemed waived and the aggrieved Party shall thereafter be barred from proceeding thereon.

13.3 No Termination Pending Dispute Resolution. Notwithstanding Section 12.1 or Section 12.3 to the contrary:

(A) An Event of Default shall not be deemed to have occurred (and hence neither Party may terminate this PPA) for failure by the other Party to pay any amount(s) allegedly due totaling less than \$100,000, if (1) such amount(s) are disputed in good faith, (2) the Party alleged to owe such amount(s) promptly commences and diligently pursues resolution of the Dispute pursuant to Section 13.1, and (3) the owed amount (if any) is paid within 10 Business Days after all dispute resolution mechanisms are completed with respect thereto.

(B) An Event of Default by Seller shall not be deemed to have occurred (and hence Company may not terminate this PPA) for failure by Seller to pay any amount(s) allegedly due totaling \$100,000 or more, if

1. such amount(s) are disputed by Seller in good faith;
2. Seller promptly commences and diligently pursues resolution of the Dispute pursuant to Section 13.1;

3. Seller (or Seller's Guarantor) either holds an Investment Grade Credit Rating, or posts cash collateral to secure its obligations (if any) with respect to the disputed amount(s), in an amount equal to the amount(s) in dispute, under a mutually agreeable third-party escrow agreement, in addition to the Security Fund; and

4. the owed amount (if any) is paid by Seller within 10 Business Days after all dispute resolution mechanisms are completed with respect thereto.

(C) An Event of Default by Company shall not be deemed to have occurred (and hence Seller may not terminate this PPA) for failure by Company to pay any amount(s) allegedly due totaling \$100,000 or more, if

1. such amount(s) are disputed by Company in good faith;

2. Company promptly commences and diligently pursues resolution of the Dispute pursuant to Section 13.1;

3. Company either holds an Investment Grade Credit Rating, or posts cash collateral to secure its obligations (if any) with respect to the disputed amount(s), in an amount equal to the amount(s) in dispute, under a mutually agreeable third-party escrow and account control agreement; and

4. the owed amount (if any) is paid by Company within 10 Business Days after all dispute resolution mechanisms are completed with respect thereto.

13.4 Governing Law. The interpretation and performance of this PPA and all actions related hereto (whether sounding in contract, tort or otherwise), shall be governed and construed in accordance with the laws of the State of Texas, exclusive of conflict of laws principles.

13.5 Venue. The Parties submit to the exclusive jurisdiction of the State courts or Federal District courts of the State of Texas for purposes of resolving any Dispute hereunder. Venue for any court proceedings shall lie exclusively in the State court located in Dallas County, Texas or the Federal District Court for the Northern District of Texas located in the city of Dallas, Texas, and the Parties hereby irrevocably submit to the exclusive jurisdiction and venue of such courts and hereby waive any objection that it now or may in the future have to any of such courts as the proper forum for any such action, suit or proceeding.

13.6 Waiver of Jury Trial. **Seller and Company each hereby knowingly, voluntarily and intentionally waive any rights they may have to a trial by jury** in respect of any litigation based hereon, or arising out of, under, or in connection with, this PPA or any course of conduct, course of dealing, statements (whether oral or written) or actions of Seller and Company related hereto and expressly agree to have any Disputes be adjudicated by a judge of the court having jurisdiction, without a jury.

## Article 14 - Force Majeure

14.1 Definition. For purposes hereof, “Force Majeure” means an event or circumstance that prevents a Party from performing its obligations under this PPA, which event or circumstance (i) was not anticipated as of the date of this PPA, (ii) is not within the control of or the result of the fault or negligence of the Party claiming excuse, and (iii) which by exercise of due diligence and foresight could not reasonably have been avoided; *provided, however*, that Force Majeure shall not include:

- a. inability, or excess cost, to procure any equipment necessary to perform this PPA;
- b. acts or omissions of a third party (including vendors and contractors to Seller), unless such acts or omissions are themselves excused by reason of Force Majeure;
- c. failure timely to apply for, or diligently pursue, the Permits set forth on Exhibit F – Seller’s Needed Permits hereto;
- d. mechanical or equipment breakdown or inability to operate, attributable to circumstances occurring within design criteria and normal operating tolerances of similar equipment;
- e. Environmental Contamination at the Site (i) discovered by, (ii) caused by, or (iii) exacerbated by and, in the case of (i), (ii) and (iii) the remediation of which is the responsibility of Seller pursuant to Applicable Law or Permit;
- f. changes in market conditions;
- g. changes of law; or
- h. labor strikes, slowdowns, work stoppages, or other labor disruptions.

By way of example only, “Force Majeure” includes any delay or failure by the Transmission Authority to perform its obligations under the Interconnection Agreement.

14.2 Applicability of Force Majeure. A Party shall be relieved of its obligations to perform this PPA and shall not be considered to be in default with respect to any obligation under this PPA if and to the extent such Party is prevented from fulfilling such obligation by Force Majeure, *provided, however*, that: (i) such Party gives prompt notice describing the circumstances and impact of the Force Majeure; (ii) the relief from its obligations sought by such Party is of no greater scope and of no longer duration than is required by the Force Majeure; (iii) such Party proceeds with due diligence to overcome the Force Majeure and resumes performance of its obligations under this PPA as soon as practicable thereafter; and (iv) such Party provides notice upon conclusion of the Force Majeure.

### 14.3 Limitations on Effect of Force Majeure.

(A) Force Majeure shall only relieve a Party of such obligations as are actually precluded by the Force Majeure.

(B) In no event will the existence of Force Majeure extend this PPA beyond its stated Term.

(C) If Force Majeure continues for an uninterrupted period of 180 Days (with respect to Force Majeure occurring prior to COD) or for an uninterrupted period of 360 Days (with respect to Force Majeure occurring after COD), either Party may, at any time following the end of such period, terminate this PPA upon notice to the other Party, without further obligation by either Party except as to costs and balances incurred prior to the effective date of such termination.

14.4 Delays Attributable to Company. Seller shall be excused from performing its obligations under this PPA where Seller can establish that such a failure was caused by any delay or failure by Company to perform its obligations under this PPA, whether or not caused by Force Majeure.

## **Article 15 - Representations and Warranties**

Each Party hereby represents and warrants to the other as follows, which representations and warranties shall be deemed to be repeated, if applicable, by each Party throughout the Term:

(A) Such Party is a valid separate legal entity, duly organized, validly existing and in good standing under Applicable Law. It is qualified to do business in the State in which the Facility is located and each other jurisdiction where the failure to so qualify would have a Material Adverse Effect on the business or financial condition of the other Party. It has all requisite power and authority to conduct its business, to own its properties, and to execute, deliver, and perform its obligations under this PPA.

(B) The Party's execution, delivery, and performance of all of its obligations under this PPA have been duly authorized by all necessary organizational action, and do not and will not:

1. subject to the Company CPs, the Seller CPs and receipt by Seller of the Seller's Needed Permits, require any consent or approval by any governing corporate or management body, other than that which has been obtained and is in full force and effect (evidence of which shall be delivered to the other Party upon its request);

2. violate any Applicable Law, the violation of which could have a Material Adverse Effect on the representing Party's ability to perform its obligations under this PPA;



3. result in a breach or constitute a default under the representing Party's formation documents, bylaws or equivalent, or under any agreement relating to its management or affairs, any indenture or loan or credit agreement, or any other agreement, lease, or instrument to which it is a party or by which it or its properties or assets may be bound or affected, the breach or default of which could reasonably be expected to have a Material Adverse Effect on the representing Party's ability to perform its obligations under this PPA; or

4. result in, or require the creation or imposition of any mortgage, deed of trust, pledge, lien, security interest, or other charge or encumbrance of any nature (other than as may be contemplated by this PPA) upon or with respect to any of the assets or properties of the representing Party now owned or hereafter acquired, the creation or imposition of which could reasonably be expected to have a Material Adverse Effect on the representing Party's ability to perform its obligations under this PPA.

(C) This PPA is a valid and binding obligation of the representing Party.

(D) The execution and performance of this PPA will not conflict with or constitute a breach or default under any contract or agreement of any kind to which the representing Party is a party or any judgment, order, or Applicable Law, applicable to it or its business.

(E) Within the meaning of the U.S. Bankruptcy Code, (i) this PPA constitutes a "master netting agreement," (ii) all transactions pursuant to this PPA constitute "forward contracts" or a "swap agreement," (iii) the representing Party is a "forward contract merchant" and "master netting agreement participant," and (iv) all payments made or to be made pursuant to this PPA constitute "settlement payments."

(F) Such Party is (i) an "eligible contract participant" as defined in the Commodity Exchange Act, as amended, 7 U.S.C. §1a(12), (ii) a "market participant" under applicable exchange and market rules; (iii) a producer, processor, or commercial user of, or a merchant handling, the commodity which is the subject of this PPA, or the products or by products thereof; and (iv) entering into this PPA solely for purposes related to its business as such.

## **Article 16 - Insurance**

16.1 Evidence of Insurance. No later than commencement of construction and thereafter prior to each applicable expiration date, Seller shall provide Company with two copies of insurance certificates acceptable to Company evidencing that insurance coverages for the Facility are in force and in compliance with the specifications for insurance coverage set forth in Exhibit E - Insurance to this PPA. Such certificates shall:

(A) name Company as an additional insured (except worker's compensation);

(B) provide that Company shall receive 30 Days prior written notice of non-renewal or cancellation of the corresponding policies (except that such notice may be 10 Days for non-payment of premiums);

(C) provide a waiver of any rights of subrogation against Company, its Affiliates and their officers, directors, agents, subcontractors, and employees; and

(D) indicate that the Commercial General Liability policy has been endorsed as described above.

16.2 Policy Requirements. All policies shall be written with insurers with an AM Best rating of at least A-VII or a Standard & Poor's rating of at least A. All policies shall be written on an occurrence basis, except as provided in Section 16.4. All policies shall contain an endorsement that Seller's policy shall be primary in all instances regardless of like coverages, if any, carried by Company. Seller may satisfy its insurance requirements using any reasonable combination of primary and secondary coverage.

16.3 No Implied Limitation. Seller's liability under this PPA is not limited to the amount of insurance coverage required herein.

16.4 Term and Modification of Insurance.

(A) All insurance required under this PPA shall cover occurrences during the Term and for a period of two years after the Term. In the event that any insurance as required herein is commercially available only on a "claims-made" basis, such insurance shall provide for a retroactive date not later than the date of this PPA and such insurance shall be maintained by Seller for a minimum of six years after the Term.

(B) Company shall have the right, at times deemed appropriate to Company during the Term, to request Seller to modify the insurance minimum limits specified in Exhibit E - Insurance in order to maintain Commercially Reasonable coverage amounts. Seller shall make Commercially Reasonable Efforts to comply with any such request.

(C) If any insurance required to be maintained by Seller hereunder ceases to be reasonably available and commercially feasible in the commercial insurance market, Seller shall provide notice to Company, accompanied by a certificate from an independent insurance advisor of recognized national standing, certifying that such insurance is not reasonably available and commercially feasible in the commercial insurance market for electric generating plants of similar type, geographic location and capacity. Upon receipt of such notice, Seller shall use Commercially Reasonable Efforts to obtain other insurance that would provide comparable protection against the risk to be insured.

16.5 Application of Proceeds. Except to the extent otherwise required by the Financing Documents, Seller shall apply any casualty insurance proceeds to reconstruction of the Facility following any material casualty to the Facility that occurs more than eighteen (18) months prior to the Scheduled Termination Date.

## Article 17 - Indemnity

17.1 Indemnification: General. Each Party (the "Indemnifying Party") shall indemnify, defend and hold the other Party (the "Indemnified Party") harmless from and against all third-party claims, demands, lawsuits (including citizen suits), losses, liabilities, fines, penalties, and expenses (including attorneys' fees) (generally, "Losses") to the extent caused by:

- a default under this PPA by the Indemnifying Party;
- a violation or alleged violation of Applicable Laws by the Indemnifying Party; and
- the negligence, intentional acts and other misconduct of the directors, officers, employees, or agents of the Indemnifying Party.

17.2 Indemnification: Environmental. Seller shall indemnify, defend and hold Company harmless from and against all Losses arising out of any claim by any Governmental Authority or other third party alleging Environmental Contamination at the Site and/or illegal disposal of Hazardous Materials off-Site, regardless of merit and regardless of Seller's responsibility therefor.

### 17.3 Limitations.

(A) The foregoing indemnification obligations shall apply notwithstanding any contributory misconduct of the Indemnified Party, but the Indemnifying Party's liability to indemnify the Indemnified Party shall be reduced in proportion to the percentage by which the Indemnified Party's misconduct caused the damages.

(B) Neither Party shall be indemnified for Losses resulting from the sole negligence or willful misconduct of the directors, officers, employees, or agents of such Party.

(C) These indemnity provisions shall not be construed to relieve any insurer of its obligation to pay claims consistent with the provisions of a valid insurance policy. Nothing in this Article 17 shall enlarge or relieve Seller or Company of any liability to the other for any breach of this PPA.

### 17.4 Procedures.

(A) Promptly after receipt by a Party of any claim or notice of the commencement of any action, administrative, or legal proceeding, or investigation as to which the indemnity provided for in this Article 17 may apply, the Indemnified Party shall provide notice thereof to the Indemnifying Party; *provided* that a delay in providing such notice shall limit the obligations of the Indemnifying Party only to the extent that such delay actually prejudices the ability of the Indemnifying Party to contest the claim or defend the proceeding.

(B) The Indemnifying Party shall assume the defense thereof with counsel designated by such Party and satisfactory to the Indemnified Party, *provided, however*, if the defendants in any such action include both the Indemnified Party and the Indemnifying Party, and the Indemnified Party shall reasonably conclude that there may be legal defenses available to it which are different from or additional to, or inconsistent with, those available to the Indemnifying Party, the Indemnified Party shall have the right to select and be represented by separate counsel, at the Indemnifying Party's expense.

(C) If an Indemnifying Party fails to assume the defense of a claim meriting indemnification, the Indemnified Party may contest, settle, or pay such claim at the expense of the Indemnifying Party, *provided, however, that* settlement or full payment of any such claim may be made only following consent of the Indemnifying Party or, absent such consent, written opinion of the Indemnified Party's counsel that such claim is meritorious or otherwise warrants settlement.

17.5 Amounts Owed. In the event that a Party is obligated for indemnification under this Article 17, the amount owing to the Indemnified Party will be the amount of the Indemnified Party's actual loss net of any insurance proceeds received by the Indemnified Party following a Commercially Reasonable effort by the Indemnified Party to obtain such insurance proceeds.

## **Article 18 - Lender Provisions**

### **18.1 Accommodation of Facility Lender.**

(A) Company shall provide such consents to collateral assignment, certifications, representations, estoppels, information or other documents, as may be reasonably requested by Seller in connection with the financing of the Facility or the Financing Documents in a manner consistent with the terms set forth in Exhibit K – Lender Consent Provisions (generally, a "Lender Consent"), *provided, however*, that in providing a Lender Consent, Company shall have no obligation to:

1. modify the terms of this PPA;
2. provide any consent or enter into any agreement that has a Material Adverse Effect on any of Company's rights, benefits, risks, or obligations under this PPA;
3. transfer or release any property or property interests of Company;
4. release or subordinate (or cause the release or subordination) of any lien on any property of Company for the benefit of Seller or the Facility Lender; or
5. permit any lien to be placed on property of Company.

(B) Seller shall reimburse, or shall cause the Facility Lender to reimburse, Company for the direct expenses (including the fees and expenses of counsel) incurred by Company in the preparation, negotiation, execution and/or delivery of each Lender Consent and any documents requested by Seller or the Facility Lender pursuant to this Section 18.1.

#### 18.2 Notices.

(A) Seller shall provide Company with a notice identifying the Facility Lender and providing appropriate contact information for the Facility Lender. Following receipt of such notice, Company shall provide to the Facility Lender a copy of each notice of alleged default delivered to Seller under Section 12.1 or Section 12.2, and Company will accept a cure thereof performed by the Facility Lender, so long as the cure is accomplished within the applicable cure period set forth in this PPA or the relevant Lender Consent.

(B) Within 10 Days following Seller's receipt of each notice of default or Facility Lender's intent to exercise any remedies under the Financing Documents, Seller shall deliver a copy of such notice to Company.

### **Article 19 - Assignment**

#### 19.1 Assignment by Seller.

(A) Except for a Permitted Transfer, Seller shall not (i) sell, exchange or otherwise transfer the Facility or any material portion thereof to any third party, or (ii) undergo any Change of Control (whether voluntary or by operation of law), absent the prior written consent of Company, which shall not be unreasonably withheld, conditioned or delayed. Company shall have no obligation to provide any consent under this Section unless:

1. Seller has complied with Sections 19.3, 19.4, if and as applicable;
2. Seller has provided to Company such information concerning the transferee's direct and indirect ownership as Company reasonably requests;
3. the transferee has substantial experience in the operation of power generation facilities akin to the Facility, either directly, through its affiliates or through a Qualified Operator;
4. the transferee (together with its parents and affiliates) enjoys an Investment Grade Credit Rating or other creditworthiness satisfactory to Company;
5. Seller has provided to Company at least 30 days' prior notice of the transaction; and

6. Seller pays or reimburses Company for the direct expenses (including the fees and expenses of counsel) incurred by Company in connection with the transaction.

(B) Except for a Permitted Transfer, any Change of Control or sale, transfer, or assignment of any interest in the Facility effected without fulfilling the requirements of this PPA shall be null, void and a breach of this PPA. Seller shall provide Company Notice of any Permitted Transfer no later than 30 Days after the transfer.

(C) Seller shall assign this PPA to any successor owner of the Facility, and shall cause such successor to assume all obligations of Seller (accrued and prospective) hereunder via a writing reasonably satisfactory to Company. Seller also may assign this PPA for collateral purposes to any Facility Lender.

(D) Except as permitted in this Section 19.1, Seller may not assign this PPA or any portion hereof. No assignment shall relieve Seller of its obligations under this PPA, nor impair any security posted by Seller unless such security is replaced in accordance with Article 11. Before this PPA is assigned by Seller, the assignee must first obtain such approvals as may be required by all applicable Governmental Authorities.

#### 19.2 Assignment by Company.

(A) Subject to Section 19.2(C), Company may assign this PPA to any Affiliate, or to any successor that provides retail electric service in all or substantially all of Company's service territory and is subject to rate and quality service regulation under the jurisdiction of the Public Utility Commission of Texas or the New Mexico Public Regulation Commission. Any other assignment of this PPA by Company shall require the prior written consent of Seller, not to be unreasonably withheld, conditioned or delayed.

(B) If an assignee of Company enjoys a Credit Rating equal to or better than Investment Grade or Company's Credit Rating as of the date of assignment (whichever is higher), Seller shall release Company from its obligations hereunder if so requested by Company. Except for the foregoing, no assignment shall relieve Company of its obligations under this PPA.

(C) Any assignee of Company shall assume all obligations of Company (accrued and prospective) hereunder via a writing reasonably satisfactory to Seller. Before this PPA is assigned by Company, the assignee must first obtain such approvals as may be required by all applicable Governmental Authorities.

#### 19.3 ROFO.

(A) Except with respect to a Permitted Transfer, at any time after the Commercial Operation Date and during the Term,

- (1) if Seller proposes to sell the Facility to an unaffiliated third party, Seller shall first offer to sell the Facility to Company via notice to Company,
- (2) if Seller's parent proposes to sell a majority of the equity interests in Seller to an unaffiliated third party, Seller shall cause its parent first to offer to sell such equity interests to Company via notice to Company, and
- (3) if Seller's parent owns no assets other than its equity interests in Seller and the parent of Seller's parent proposes to sell a majority of the equity interests in Seller's parent to an unaffiliated third party, Seller shall cause its parent's parent first to offer to sell such equity interests to Company via notice to Company

(in each case, a "ROFO Notice"). Any ROFO Notice shall describe the proposed transaction, including the minimum price, status of title to the Site, liabilities to be assumed and other terms which Seller or its relevant parent (as applicable) is willing to accept to proceed with the contemplated transaction. The contents of a ROFO Notice shall be deemed Confidential Information for purposes of Section 20.18 below.

(B) Following issuance of a ROFO Notice, Seller shall allow Company 60 Days to investigate the proposed transaction and conduct due diligence. Due diligence shall include such physical inspections, surveys and operating tests of the Facility and the Site, such reviews of Seller's contracts, books and records, and interviews of such personnel, as Company may reasonably request. All information obtained by Company from such investigations shall be deemed Confidential Information subject to Section 20.18 below. Within such 60-Day period, Company may elect to purchase the Facility or the relevant equity interests (as applicable) on substantially the same terms as set forth in the ROFO Notice. If Company fails to notify Seller of Company's election within such 60-Day period, Company shall be deemed to have rejected the transaction.

(C) If Company elects to purchase the Facility or the specified equity interests (as applicable), the Parties shall negotiate in good faith towards the execution of a mutually satisfactory, definitive contract for the transaction (a "PSA"). The PSA shall be in a form customary for such a transaction, will include the price and other terms set forth in the ROFO Notice, including customary and reasonable representations, warranties, indemnities, covenants and agreements, which shall survive for customary and reasonable periods of time following the execution of the PSA.

(D) If Company rejects the transaction described in a ROFO Notice, Seller shall have the right to sell the Facility (or Seller's relevant parent shall have the right to sell the specified equity interests, as applicable) on terms not more favorable to Seller or its parent vs. the terms set forth in the ROFO Notice, at any time within the twelve-month period following issuance of the ROFO Notice. If Seller or its relevant

parent fails to close a transaction on such terms within such 12-month period, any sale of the Facility or equity interests in Seller shall again be subject to this Section 19.3.

(E) This Section 19.3 shall be specifically enforceable by Company, without bond and without the need to prove irreparable harm.

(F) Seller shall cooperate in all respects reasonably necessary for Company to exercise its ROFO rights, and shall operate the Facility in the ordinary course of business following the date of issuance of a ROFO Notice.

#### 19.4 PFT.

(A) Seller shall give Company at least 90 Days' prior notice (a "PFT Notice") of any Pending Facility Transaction that does not otherwise trigger Company's ROFO rights under Section 19.3, in order to provide Company with an opportunity to discuss and negotiate with Seller the possible sale of the Facility to Company. Any PFT Notice shall include a fair summary of Seller's plans with respect to the Facility in connection with the proposed Pending Facility Transaction, to the extent then known by Seller. The contents of a PFT Notice shall be deemed Confidential Information for purposes of Section 20.18 below.

(B) Seller shall have no obligation to sell nor shall Company have any obligation to purchase the Facility, following any PFT Notice. Issuance of a PFT Notice shall not relieve Seller of its obligation to offer a ROFO to Company if and when applicable pursuant to Section 19.3. In the event that the transaction giving rise to the PFT Notice has not been completed within twelve months following a PFT Notice, Seller shall be required to resubmit a PFT Notice for such transaction.

(C) Any breach of this Section 19.4 shall entitle Company to liquidated damages from Seller in the amount of \$1,000,000.

(D) For purposes hereof, a "Pending Facility Transaction" or "PFT" means:

1. except with respect to a Permitted Transfer, any Change of Control of Seller;

2. the issuance by Seller or any of its Affiliates of a request for proposals or the response by Seller or any of its Affiliates to a request for proposal or similar process (e.g., auction) for the purchase or sale to any unaffiliated third party of any equity interests in Seller or the Facility, or any group(s) of assets or equity interests that includes the Facility;

3. the commencement by Seller or any of its Affiliates of substantive negotiations with any unaffiliated third party with respect to the sale of any equity interests in Seller or the Facility, or any group(s) of assets or equity interests that includes the Facility; or



4. the execution by Seller or any of its Affiliates of any letter of intent, memorandum of understanding or similar document, whether or not legally binding, which contemplates the sale or lease to an unaffiliated third party of any equity interests in Seller or the Facility or any group(s) of assets or equity interests that includes the Facility;

*provided, however,* that a PFT does not include (i) any financing or refinancing of the Facility Debt or a tax equity financing, (ii) any transaction among Affiliates of Seller, (iii) a Permitted Transfer and/or (iv) any transaction for which Seller offers ROFO rights to Company under Section 19.3.

#### 19.5 Option.

(A) Seller hereby grants to Company, and its Affiliates the option to purchase the Facility Property on terms and conditions set forth in this Section ("Option"). The Option may be exercised by Company only if the following two conditions are met: 1) the NextEra YieldCo has been dissolved or wound up; and, (2) the Option is exercised within six (6) months prior to the Scheduled Termination Date, with the closing of the Option to occur upon the termination of this PPA.

1. For purposes of the Option, the term "NextEra YieldCo" means, collectively, NextEra Energy Operating Partners, LP and any entity in which NextEra Energy Operating Partners, LP holds, directly or indirectly, fifty percent (50%) or more of the equity interests in Seller.

2. For purposes of the Option, the term "Facility Property" means, collectively, all property rights necessary for the use of the Facility for its intended purpose, including (i) the Facility; (ii) the Site; (iii) Seller's Interconnection Facilities; (iv) the Facility collection facilities and substation; (v) Seller's rights and obligations under the Interconnection Agreement; (vi) Permits, and all material contracts; and (vii) all Facility fixtures, equipment and personal property.

(B) In the event Company exercises its Option consistent with this provision, Seller shall convey the Facility Property to Company or its designated Affiliate upon payment to Seller of an amount equal to the higher of (i) fair market value of the Facility Property (including any break-up or pre-payment fees associated with a financing), or (ii) the then existing balance of all Facility Debt.

1. Within thirty (30) Days of Company's Option exercise, the Parties shall jointly appoint a qualified, independent appraiser. If the Parties cannot agree, then each Party shall select an appraiser and the two appraisers shall appoint the appraiser. Seller shall provide all information regarding the Facility Property necessary for the appraiser's determination of fair market value. The appraiser shall complete its appraisal within sixty (60) Days of receipt of all such necessary data. The costs of the appraisal shall be included as part of the purchase price. During the period in which the appraiser is evaluating the Facility Property, as applicable, Seller shall

allow Company or its Affiliate the Commercially Reasonable opportunity to investigate the proposed transaction and conduct due diligence.

2. Upon determination of fair market value of the Facility Property, the Parties shall use Commercially Reasonable Efforts to negotiate and sign definitive agreements consummating the transaction on an “as is, where is” basis within ninety (90) Days. Upon payment of the purchase price, Seller shall execute and deliver to Company or its Affiliate all instruments necessary to effect transfer of ownership of the Facility Property to Company or its Affiliate, subject only to the liens of Facility Lender which Lenders the Company or its Affiliate elects to assume.

3. After the Company's Option is exercised and continuing through closing on any resulting sale, Seller shall maintain the physical Facility Property in Commercially Reasonable condition and to perform in accordance with those contractual and other obligations under agreements comprising any portion of the Facility Property.

19.6 Reserved.

## **Article 20 - Miscellaneous**

20.1 Notices.

(A) Notices required by this PPA shall be in writing and addressed to the other Party at the addresses noted in Exhibit D - Notices, as either Party updates such addresses from time to time by notice to the other Party. Notices shall be deemed effective when receipt is acknowledged in writing by the counterparty (or absent such acknowledgement, when delivered via third-party messenger or via FedEx or other reputable overnight courier service). Any notice shall be deemed to have been received by the close of the Business Day on which it was delivered. Real-time or routine communications concerning Facility operations shall be exempt from this Section 20.1(A).

(B) The Parties recognize the need for accurate communications between them. Each Party consents to the recording of telephone conversations between their employees and representatives, related to the performance and administration of this PPA.

20.2 Taxes.

(A) Company shall purchase all Renewable Energy on a wholesale basis, for resale to Company's wholesale and retail customers. Company shall obtain and provide Seller with any certificates required by any Governmental Authority or otherwise reasonably requested by Seller to evidence that the deliveries of Renewable Energy hereunder are sales for resale.

(B) As between the Parties, Company shall be solely responsible for the payment of (1) any sales, use or equivalent taxes imposed by Governmental

Authorities, whether now in existence or hereafter enacted, on the purchase of Renewable Energy hereunder at the Point of Delivery, and (2) any taxes imposed by Governmental Authorities, whether now in existence or hereafter enacted, on the transmission of Renewable Energy beyond the Point of Delivery.

(C) Subject to Section 20.2(B), Seller shall be solely responsible for any and all present and future taxes and other impositions of Governmental Authorities relating to the construction, ownership or leasing, operation or maintenance of the Facility and the Site (including *ad valorem* taxes on the Facility and the Site), and any taxes imposed prior to the Point of Delivery with respect to the products and services to be sold and delivered to Company hereunder, whether calculated based upon cost, value, labor, capital, production, savings, green attributes or other parameters. Seller's prices under Article 8 are inclusive of such taxes and impositions during the Term, and Seller assumes the risk of changes in such taxes after the date hereof.

(D) The Parties shall cooperate to minimize tax exposure, *provided, however*, that neither Party shall be obligated to incur any financial burden to reduce taxes for which the other Party is responsible hereunder.

20.3 Applicable Laws. Each Party shall comply with all Applicable Laws (including the Transmission Authority Tariff), except for any non-compliance that (individually or in the aggregate) could not reasonably be expected to have a Material Adverse Effect on the other Party or on such Party's ability to perform this PPA.

(A) As applicable, each Party shall give all required notices, shall procure and maintain all Permits necessary for performance of this PPA, and shall pay its respective charges and fees in connection therewith.

(B) Each Party shall promptly disclose to the other Party, any violation of any Applicable Laws arising out of the Facility and/or performance of this PPA.

(C) Upon permanent cessation of generation from the Facility, Seller shall decommission and remove the Facility and remediate the Site as, if and when required by Applicable Laws.

(D) Seller acknowledges that as a government contractor Company is subject to Applicable Laws regarding equal employment opportunity and affirmative action, including 41 C.F.R. §60-1.4(a)(1-7). Such Applicable Laws may also be applicable to Seller as a subcontractor to Company. All such Applicable Laws shall be deemed to be incorporated herein as required by Applicable Law.

(E) Each Party assumes the risk of changes in Applicable Laws following the date hereof, that affect such Party's costs of ownership and operation of its assets, and its performance of this PPA, except as otherwise specifically set forth herein.

20.4 Fines and Penalties. Seller shall pay when due all fees, fines, penalties and costs incurred by Company, Seller and/or their agents, employees or contractors arising from noncompliance by Seller, its employees, or subcontractors with any

provision of this PPA, or any contractual obligation, Permit or requirements of Applicable Law, except for such fines, penalties and costs that are being actively contested in good faith and with due diligence by Seller and for which adequate financial reserves have been set aside to pay such fines, penalties or costs in the event of an adverse determination.

#### 20.5 Rate Changes.

(A) The terms and conditions and the rates for service specified in this PPA shall remain in effect for the Term hereof. Neither Party shall seek (nor support any third party seeking) any prospective or retroactive change to the rates or terms of service under this PPA pursuant to Section 205, 206 or 306 of the Federal Power Act.

(B) The standard of review for changes to this PPA whether proposed by a Party, a non-party, or FERC acting *sua sponte* shall be the “public interest” standard of review set forth in *United Gas Pipe Line v. Mobile Gas Service Corp.*, 350 U.S. 332 (1956) and *Federal Power Commission v. Sierra Pacific Power Co.*, 350 U.S. 348 (1956) (aka the “Mobile-Sierra doctrine”), as interpreted in *Morgan Stanley Capital Group, Inc. v. Public Util. Dist. No. 1*, 128 S. Ct. 2733 (2008).

20.6 Certifications. Each Party shall deliver or cause to be delivered to the other Party certificates of its officers, accountants, engineers or agents as to matters as may be reasonably requested, and shall make available personnel and records relating to the Facility to the extent that the requesting Party requires the same in order to fulfill any regulatory reporting requirements, or to assist the requesting Party in litigation, including administrative proceedings before the Public Utility Commission of Texas and/or the New Mexico Public Regulation Commission.

20.7 Disclaimer of Third Party Beneficiaries. In executing this PPA, Company does not and does not intend to extend its credit or financial support for the benefit of any Facility Lender or any other third party transacting with Seller. Nothing in this PPA shall be construed to create any duty to, or standard of care with reference to, or any liability to, any person not a party to this PPA.

#### 20.8 Relationship of the Parties.

(A) This PPA shall not be interpreted to create an association, joint venture, or partnership between the Parties, nor to impose any partnership obligation or liability upon either Party. Except as specifically provided for in this PPA to the contrary, neither Party shall have any right, power, or authority to enter into any agreement or undertaking for, or act on behalf of, or to act as an agent or representative of, the other Party.

(B) Seller shall be solely liable for the payment of all wages, taxes, and other costs related to the employment of persons to perform such services, including all federal, state, and local income, social security, payroll, and employment taxes and statutorily mandated workers’ compensation coverage. None of the persons employed

by Seller shall be considered employees of Company for any purpose; nor shall Seller represent to any person that he or she is or shall become a Company employee.

20.9 Survival of Obligations. Cancellation, expiration, or earlier termination of this PPA shall not relieve the Parties of obligations, including warranties, remedies, or indemnities, that by their nature should survive such cancellation, expiration, or termination, which obligations shall survive for the period of the applicable statute(s) of limitation.

20.10 Severability. In the event any of the terms, covenants, or conditions of this PPA, its Exhibits, or the application of any such terms, covenants, or conditions, shall be held invalid, illegal, or unenforceable by any court or administrative body having jurisdiction, all other terms, covenants, and conditions of the PPA and their application not adversely affected thereby shall remain in force and effect; *provided, however, that* Company and Seller shall negotiate in good faith to attempt to implement an equitable adjustment in the provisions of this PPA with a view toward effecting the purposes of this PPA by replacing the provision that is held invalid, illegal, or unenforceable with a valid provision the economic effect of which comes as close as possible to that of the provision that has been found to be invalid, illegal or unenforceable.

20.11 Complete Agreement; Amendments. The terms and provisions contained in this PPA constitute the entire agreement between Company and Seller with respect to the Facility and shall supersede all previous communications, representations, or agreements, either verbal or written, between Company and Seller with respect to the sale of Renewable Energy from the Facility. Any amendment of this PPA, or any waiver of any provision hereof, shall be evidenced by a writing signed by the Party/ies to be bound thereby.

20.12 Waiver. The failure of either Party to enforce or insist upon compliance with or strict performance of any of the terms or conditions of this PPA, or to take advantage of any of its rights hereunder, shall not constitute a waiver or relinquishment of any such terms, conditions, or rights, but the same shall be and remain at all times in full force and effect.

20.13 Binding Effect. This PPA is binding upon and shall inure to the benefit of the Parties hereto and their respective successors, legal representatives, and assigns.

20.14 Headings. Captions and headings used in this PPA are for ease of reference only and do not constitute a part of this PPA.

20.15 Counterparts. This PPA may be executed in counterparts, and each executed counterpart shall have the same force and effect as an original instrument.

20.16 Press Release. Upon the request of either Party, the Parties shall develop a mutually agreed joint press release to be issued describing the location, size and nature of the Facility, the term of this PPA, and other relevant factual information about the relationship.

20.17 Exhibits. Either Party may change the information in Exhibit D - Notices at any time by notice without the approval of the other Party. All other Exhibits may be changed to the extent allowed by specific provisions of this PPA or with the mutual consent of both Parties.

20.18 Confidentiality.

(A) For purposes hereof, "Confidential Information" means:

1. information specifically designated as Confidential Information in this PPA; and
2. written information delivered by one Party to the other from time to time during the Term, which information is labeled prominently as "Confidential," "Proprietary" or the like and specifically references this PPA.

*provided, however,* that "Confidential Information" shall not include information that:

- (x) is publicly available as of the date hereof, or becomes publicly available during the Term through no fault of the recipient Party;
- (y) can be documented was independently developed by the recipient Party; and/or
- (z) is disclosed to the recipient Party from an ultimate source other than the protected Party, without breach of this PPA by the recipient Party.

(B) The recipient Party shall (i) maintain the confidentiality of all Confidential Information of the protected Party, using the same degree of care used by the recipient Party to protect its own Confidential Information (and in any event not less than a reasonable degree of care), and (ii) shall use Confidential Information only in connection with its performance of this PPA. Confidential Information may be disclosed by the recipient Party to its agents, employees, directors, officers, consultants, auditors, lenders and equity investors, subject to their acceptance of the obligations of confidentiality imposed hereby and for whose violations of this Section 20.18 the recipient Party shall be responsible.

(C) In the event that Confidential Information is disclosed to a State Regulatory Agency, its staff, intervenors or consumer counsel in any regulatory or administrative proceedings before a State Regulatory Agency, the disclosing Party shall submit such Confidential information in accordance with applicable State Regulatory Agency confidentiality rules and procedures. In the event that Confidential Information must otherwise be disclosed by Applicable Law (e.g. pursuant to subpoena or civil discovery), the Party required to make disclosure shall notify the protected Party sufficiently in advance to allow the protected Party a reasonable opportunity to obtain a protective order or seek other remedies, prior to disclosure by the recipient Party.

*[remainder of this page intentionally left blank]*

IN WITNESS WHEREOF, the Parties have executed this PPA as of the date first set forth above.

*Seller:*

**Bonita Wind Energy, LLC**

By:   
\_\_\_\_\_  
Michael O'Sullivan  
Senior Vice President

*Company:*

**Southwestern Public Service Company**

By: \_\_\_\_\_  
David T. Hudson  
President, Southwestern Public Service  
Company

IN WITNESS WHEREOF, the Parties have executed this PPA as of the date first set forth above.

*Seller:*

**Bonita Wind Energy, LLC**

By: \_\_\_\_\_  
Michael O'Sullivan  
Senior Vice President

*Company:*

**Southwestern Public Service Company**

By: David T. Hudson  
David T. Hudson  
President, Southwestern Public Service  
Company



## EXHIBIT A

### DEFINITIONS

The following terms shall have the meanings set forth herein:

“Actual Damages” has the meaning set forth in Section 12.4(C).

“Affiliate” of any designated Person means any person or entity that directly or indirectly controls, is under the control of, or is under common control with, the designated Person by the power to direct or cause the direction of the management of the policies of designated Person, whether through ownership interest, by contract or otherwise.

“AGC” or “Automatic Generation Control” means the equipment and capability of an electric generation facility automatically to adjust the generation quantity within the applicable Balancing Authority with the purpose of interchange balancing and specifically, the Facility’s capability of accepting an AGC Set-Point electronically, and the automatic adjustment and regulation of the Facility’s energy production via the SCADA System.

“AGC Protocols” means the protocols for AGC included in Exhibit I - AGC Protocols; Data Collection; Technical Specifications, as such protocols may be modified from time to time in accordance with Section 10.7.

“AGC Remote/Local” means a handshake electronic signal sent from the Facility to the EMCC AGC system, and from the EMCC AGC system to the Facility, indicating the Facility is receiving AGC Set-Point locally (from the Facility) or remotely (EMCC AGC system) and is following that AGC Set-Point.

“AGC Set-Point” means the Company-generated analog or digital signal sent by the SCADA System to the Facility, representing the quantity of Renewable Energy to be generated by the Facility. The AGC Set-Point is calculated by the EMCC AGC system and communicated electronically to the Facility via the SCADA System.

“Applicable Law” means all laws, statutes, treaties, codes, ordinances, regulations and rules, certificates, orders, licenses, and permits of any Governmental Authority that are applicable to a Party, the business of a Party or the Facility, now in effect or hereafter enacted, including amendments to or interpretations of any of the foregoing by a Governmental Authority having jurisdiction, and all applicable judicial, administrative, arbitration and regulatory decrees, judgments, injunctions, writs, orders, awards and/or like actions.

“Back-Up Metering” shall have the meaning set forth in Section 5.2(B).

“Balancing Authority” means the system of electrical generation, distribution and transmission facilities within which generation is regulated in order to maintain interchange schedules with other such systems.

“Business Day” means any Day that is not a Saturday, a Sunday, or a NERC recognized holiday.

“Capacity Resource” means the amount of net generating capacity associated with the Facility for which capacity credit may be obtained under applicable ERO or Transmission Authority planning reserve procedures and requirements, if any.

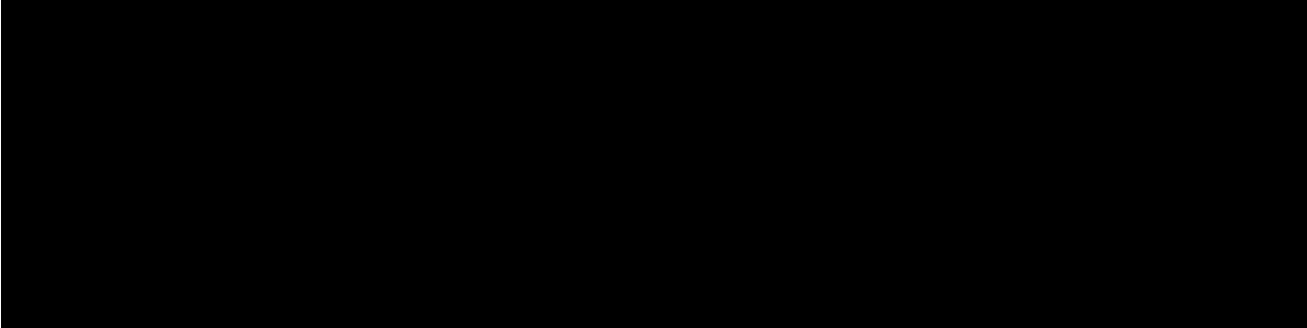

“Change of Control” means the occurrence of any one of the following events with respect to Seller or any direct or indirect owner of a majority of the ownership interests in Seller: (i) a transfer of a majority of the ownership interests in Seller or such owner; or (ii) any consolidation or merger of Seller or such owner in which Seller or such owner, as the case may be, is not the continuing or surviving entity, or (iii) a sale or conveyance of any direct or indirect ownership interest in Seller following which NextEra Energy, Inc. is no longer the direct or indirect owner of at least 50% of the ownership interests of Seller; *provided, however, that* a Change of Control shall not be deemed to have occurred as a result of a Permitted Transfer.

“COD Conditions” means all of the requirements that must be satisfied by Seller as a prerequisite to achieving Commercial Operation. The COD Conditions are set forth in Section 4.5.

“Code” means the United States Internal Revenue Code of 1986, as amended from time to time, and any successor statute.

“Commercial Operation” means the period beginning on the Commercial Operation Date and continuing through the balance of the Term of this PPA.

“Commercial Operation Date” or “COD” shall have the meaning set forth in Section 4.5.

“Commercial Operation Year” shall have the meaning set forth in Section 4.5(E).

“Commercially Reasonable” or “Commercially Reasonable Efforts” means, with respect to any action to be taken or attempted by a Party under this PPA, the level of effort in light of the facts known to such Party at the time a decision is made that: (a) can reasonably be expected to accomplish the desired action at a reasonable cost; (b) is consistent with Good Utility Practices; and (c) takes into consideration the

amount of advance notice required to take such action, the duration and type of action, and the competitive environment in which such action occurs.

“Compensable Curtailment” and “Compensable Curtailment Energy” shall have the meanings set forth in Section 8.3(B).

“Compliance Expenditures” shall have the meaning set forth in Section 5.2(C).

“Confidential Information” shall have the meaning set forth in Section 20.18(A).

“Construction Contracts” shall have the meaning set forth in Section 4.1.

“Construction Milestones” means the dates set forth in Exhibit B – Construction Milestones.

“Credit Rating” of any Person means the lowest rating assigned to such Person’s long-term debt or deposit obligations (unenhanced by third-party support) by Standard & Poors, Moody’s and Fitch Ratings. If such Person has no outstanding long-term debt or deposit obligations, or if no rating is assigned to such obligations, “Credit Rating” shall mean the lowest general corporate credit rating or long-term issuer rating assigned to such Person by Standard & Poors, Moody’s or Fitch Ratings.

“Damage Cap” shall have the meaning set forth in Section 12.4.

“Day” means a calendar day.

“Dispute” shall have the meaning set forth in Article 13.

“Electric Metering Devices” means revenue quality meters, metering equipment and data processing equipment used to measure, record and transmit data with respect to the output of Renewable Energy from the Facility, including metering current transformers and metering voltage transformers.

“Eligible Energy Resource” means any generation resource eligible to be certified to generate, claim, own or use Renewable Energy Credits and green tags pursuant to the protocols and procedures developed and approved by applicable Government Authorities for the REC Registration Program.

“Emergency” means any event or occurrence after the date of this PPA that results in the declaration of an Emergency Condition under and as defined in the Interconnection Agreement.

“Energy Markets Control Center” or “EMCC” means Company's merchant representatives responsible for dispatch of generating units, including the Facility.

“Energy Payment Rate” shall have the meaning set forth in Exhibit J.

“Energy Resource Interconnection Service” means the type of interconnection service which allows Seller to connect the Facility to the transmission or distribution system, as applicable, as an “Energy Resource” as defined by the Transmission Tariff, and be eligible to deliver the Facility’s output using the existing firm or non-firm capacity on the transmission system on an as-available basis.

“Environmental Contamination” shall have the meaning set forth in Section 4.2.

“ERO” means the Electric Reliability Organization certified by FERC pursuant to Section 215 of the Federal Power Act or any successor organization. The certified ERO as of the date of this PPA is the Southwest Power Pool, Inc., or its successor as to any function.

“Event of Default” shall have the meaning set forth in Article 12.

“Facility” means Seller’s electric generating facilities, associated balance of plant, parts, fixtures and equipment, and all equipment necessary to interconnect to the Transmission Authority’s System, all such facilities as associated with each of the Phase I and Phase II components of the Facility and as further described in Exhibit C - Facility Description, including Seller’s rights to the Site and all of the following: buildings, turbines, generators, step-up transformers, output breakers, facilities necessary to connect to the Interconnection Point, protective and associated equipment, improvements, and other tangible and intangible assets, contract rights, Permits, easements, rights of way, surface use agreements and other interests or rights in real estate, owned or used for construction, operation, maintenance, generation and delivery of the capacity and energy subject to this PPA.

“Facility Debt” means the obligations of Seller or its Affiliates to any Facility Lender pursuant to the Financing Documents, including distributions, indemnities, principal of, premium and interest on indebtedness, fees, expenses or penalties, amounts due upon acceleration, prepayment or restructuring, swap or interest rate hedging breakage costs and any fees or interest due with respect to any of the foregoing.

“Facility Lender” means, collectively, any lenders or tax equity investors providing Facility Debt, including any successors or assigns thereof.

“Federal Power Act” means the provisions of 16 U.S.C. §791(A) *et seq.* and amendments or supplements thereto.

“FERC” means the Federal Energy Regulatory Commission or any successor agency.

“Financing Documents” means the loan and credit agreements, notes, bonds, indentures, security agreements, lease financing agreements, mortgages, deeds of trust, interest rate exchanges, swap agreements and other documents relating to the development, bridge, construction or permanent debt financing and/or tax equity or portfolio financing for the Facility, including any credit enhancement, credit support,

working capital financing, or refinancing documents, and any and all amendments, modifications, or supplements to the foregoing that may be entered into from time to time at the discretion of Seller in connection with development, construction, ownership, leasing, operation or maintenance of the Facility.

“Forced Outage” means any condition at the Facility that requires the immediate and unplanned removal of the Facility, or at least ten percent thereof, from service, another outage state, or a reserve shutdown state, resulting from immediate mechanical/electrical/hydraulic control system trips and operator-initiated trips in response to abnormal Facility conditions or alarms.

“Guaranteed Mechanical Availability Factor” shall have the meaning set forth in Exhibit M.

“Good Utility Practices” means the practices, methods, standards and acts engaged in or approved by a significant portion of the applicable segment of the electric power generation industry pertaining to facilities of the type, similar size and location to the Facility that, at a particular time, in the exercise of Commercially Reasonable judgment, in light of the facts that are known (or reasonably should have been known) at the time a decision was made, would have been expected to accomplish the desired result in a manner consistent with Applicable Law, Permits, codes, standards, equipment manufacturer’s recommendations, reliability, safety, environmental protection, economy, and expedition. Good Utility Practices is not limited to the optimum practice, method, standard or act to the exclusion of all others, but rather to those practices, methods, standards and acts generally acceptable or approved by a significant portion of the applicable segment of the electric power generation industry in the relevant region, during the relevant period.

“Governmental Authority” means any federal, state, local or municipal governmental body; any governmental, quasi-governmental, regulatory or administrative agency, commission, body or other authority exercising or entitled to exercise any administrative, executive, judicial, legislative, policy, regulatory or taxing authority or power; and/or any court or governmental tribunal. By way of example only, “Governmental Authorities” include NERC, the ERO, the Market Operator (if any), an applicable State Regulatory Agency, the Transmission Authority and FERC, and successor organizations.

“Guarantor” has the meaning set forth in Section 11.3(C).

“Hale Project” " has the meaning set forth in Section 6.2.

“Interconnection Agreement(s)” means the separate contract for interconnection of the Facility to the Transmission Authority’s System, as such agreement may be amended from time to time. For purposes of this PPA, the Interconnection Agreement shall be interpreted to include any third party facility construction agreement or other agreement required by the Transmission Authority to interconnect the Facility in accordance with the Transmission Tariff. For the

avoidance of doubt, “Interconnection Agreement” excludes any provisional interconnection agreement.

“Interconnection Facilities” means, with respect to the Facility, those facilities designated in the Interconnection Agreement for the direct purpose of interconnecting each of the Phase I and Phase II components of the Facility to the Transmission Authority’s System at the Interconnection Point, along with any easements, rights of way, surface use agreements and other interests or rights in real estate reasonably necessary for the construction, operation and maintenance of such facilities, whether owned by Seller, the Transmission Authority or another entity. This equipment is conceptually depicted in Exhibit C - Facility Description to this PPA.

“Interconnection Point” means, with respect to the Facility, the physical point within the operational authority of the Transmission Authority as specified in the Interconnection Agreement at which electrical interconnection is made between the Facility and the Transmission Authority’s System in accordance with the Transmission Tariff and the Interconnection Agreement.

“Investment Grade” means that the long-term Credit Rating of such Person satisfies two of the following three rating requirements (a) BBB- or better by Fitch Ratings, (b) BBB- or better by Standard & Poor’s, or (c) Baa3 or better by Moody’s. For the avoidance of doubt, if such Person satisfies any two of the foregoing rating requirements the standard shall have been met.

“kW” means kilowatt, and “kWh” means kilowatt hour.

“Lender Consent” shall have the meaning set forth in Section 18.1.

“Maintenance Schedule” has the meaning set forth in Section 10.2.

“Market Operator” means the entity that instructs market participants and/or generators to regulate generation assets (including the Facility) within any energy market in which Company participates, based on price-based offer curves for the purpose of matching generation output to system load demand while maintaining bulk electric system reliability. If such entity is the Transmission Authority, then “Market Operator” shall mean such entity acting in its capacity as such.

“Material Adverse Effect” means any effect (or effects taken together) that is materially adverse to the present or future business, operations, assets, liabilities, properties, results in operations or condition (financial or otherwise), prospects, or property of a Party, its business, or this PPA.

“MW” means megawatt or one thousand kW, and “MWh” means megawatt hours.

“Nameplate Capacity” of the Facility means the sum of the designed maximum outputs of each Wind Turbine comprising the Facility, as designated by the turbine manufacturer.

“NERC” means the North American Electric Reliability Council or any successor organization.

“Non-Compensable Curtailment” shall have the meaning set forth in Section 8.3(B).

“Operating Committee” means one representative each from Company and Seller, pursuant to Section 10.7.

“Operating Procedures” means those procedures developed by the Operating Committee pursuant to Section 10.7, if any.

“Operating Records” means all agreements associated with the Facility, operating logs, blueprints for construction, operating manuals, all warranties on equipment, and all documents, whether in printed or electronic format, that Seller uses or maintains for the operation of the Facility.

“Park Potential” means the number of MW that depicts Seller’s real time calculation of the Potential Energy capable of being provided by the Facility, the Phase I and Phase II components of the Facility, as applicable, to Company at the Point of Delivery. Park Potential shall be calculated using the best-available data obtained through Commercially Reasonable methods; and shall be dependent upon measured wind speeds, power curves, Wind Turbine availability, and derate(s) and transmission line losses, and any other adjustment necessary to accurately reflect the Potential Energy at the Point of Delivery. Park Potential should be provided to the Company in real time through the Company’s SCADA System in accordance with the AGC Protocols.

“Party” and “Parties” shall have the meanings set forth in the introductory paragraph.

“Pending Facility Transaction” or “PFT” shall have the meaning set forth in Section 19.4.

“Permit” shall have the meaning set forth in Section 4.3.

“Permitted Extension” shall have the meaning set forth in Section 4.5(A)(2).

“Permitted Transfer” means any of the following (a) transactions among Affiliates of Seller, including any corporate reorganization, merger, combination or similar transaction or transfer of assets or ownership interests involving Seller or its Affiliates; *provided* (i) NextEra Energy, Inc. retains the authority, directly or indirectly, to Control the Seller, or (ii) a wholly-owned, indirect subsidiary of NextEra Energy, Inc. operates the Facility, (b) any exercise by a Facility Lender of its rights and remedies under the Financing Documents, (c) a Change of Control of NextEra Energy, Inc., (d) any change of economic and voting rights triggered in Seller’s organization documents arising from the financing of the Facility and which does not result in the transfer of ownership, economic or voting rights in any entity that had no such rights

immediately prior to the change, (e) the direct or indirect transfer of shares of, or equity interests in, the Seller to a Facility Lender; or (f) a transfer of the Facility or the Facility packaged with any of the following (i) all or substantially all of the assets of NextEra Energy Resources, LLC (“NEER”) or NextEra Energy, Inc.; (ii) all or substantially all of NEER’s or its ultimate parent company’s renewable energy generation portfolio; or (iii) all or substantially all of NEER’s or its ultimate parent company’s wind generation portfolio; *provided, that* in the case of each of (i), (ii) and (iii), the entity that operates the Facility following such transfer is (or contracts with) a Qualified Operator; *provided, further* that prior to or concurrent with any Permitted Transfer, the transferee shall agree in writing to be bound by the terms and conditions hereof and furnish a copy of the transfer to the Company.

“Permitting Delay” shall have the meaning set forth in Section 4.5(A)(1).

“PFT Notice” shall have the meaning set forth in Section 19.4.

“PI System” means the “plant information” system for the Facility, as described and implemented in Exhibit I - AGC Protocols; Data Collection; Technical Specifications.

“Point of Delivery” means, with respect to the Facility, the physical point within the operational authority of Transmission Authority at which Seller makes available and delivers to Company the Renewable Energy being provided by Seller to Company under this PPA. The Point of Delivery is at the high side of the step-up transformer at the applicable Substation for each of the Phase I and Phase II components of the Facility, as specified in Exhibit C - Facility Description to this PPA.

“Potential Energy” for any period of time means the MWh of energy that the Facility, the Phase I and Phase II components of the Facility, as applicable, is actually capable of delivering to the Point of Delivery by virtue of the Park Potential during such period.

“PTCs” means Production Tax Credits applicable to electricity produced from certain renewable resources pursuant to 26 U.S.C. §45, or such substantially equivalent tax credit that provides Seller with a tax credit based on energy production from the Facility.

“Qualified Operator” means an operator of wind generation facilities that is nationally recognized and that demonstrates to Company’s reasonable satisfaction that such operator has sufficient experience to successfully operate the Facility, including a minimum of three (3) years’ experience in the wind energy generation and operation business, and owns, controls or operates a minimum of 6,000 MWs of wind energy generation capacity.

“REC Registration Program” means the applicable State, regional, or federal program established to register Eligible Energy Resources such as the Facility, and create and certify RECs arising from energy generated from such Resources,



including any rights associated with any renewable energy information or tracking system that exists or may be established by Applicable Law with regard to monitoring, registering, tracking, certifying, or trading such credits. For purposes of this PPA, the REC Registration program shall mean the Midwest Renewable Energy Tracking System (aka M-RETS).

“Renewable Energy” means in **Texas**: electric energy generated from Renewable Energy Technology, as defined in PUCT Substantive Rule 25.173(c)(17) and in **New Mexico**: renewable energy within the meaning of Part 572 of Title 17, Chapter 9, New Mexico Administrative Code.

“Renewable Energy Credit” or “REC” means in **Texas**: pursuant to PUCT Substantive Rule 25.173(c)(13), one MWh of Renewable Energy that is physically metered, verified in Texas and meets the requirements set forth in subsection (e) of PUCT Substantive Rule 25.173 and in **New Mexico**: a renewable energy certificate within the meaning of Part 572 of Title 17, Chapter 9, New Mexico Administrative Code, with respect to 1,000 kWh of generated Renewable Energy. For the avoidance of doubt, RECs exclude (i) PTC’s, investment tax credits and any other local, state or federal deductions and tax credits providing a tax benefit to Seller based on ownership of, or energy production from, the Facility, and (ii) depreciation and other tax benefits arising from ownership or operation of the Facility unrelated to its status as a generator of renewable or environmentally clean energy.

“Replacement Power Costs” for any period mean the costs incurred by Company to replace the products and services which Seller was required to provide under this PPA (but failed to so provide) during such period, less the sum of any payments from Company to Seller under this PPA that were eliminated with respect to such period as a result of such failure. Replacement Power Costs shall be determined on an hourly basis and shall equal the sum of the following for each hour where the following calculation achieves a positive number:

Hourly Replacement Power Costs = (A + B + C + D) – E, where

“A” = the product of (x) the number of MW of lost capacity, derived by subtracting the number of MW of capacity of the Facility that qualifies for capacity credit actually made available to Company from the amount of qualifying capacity associated with the entire Facility, and (y) the applicable market price for capacity made available to Company’s system, for such hour;

“B” = the price paid by Company for the MWh of energy purchased by Company to replace the Contract Energy that was not delivered under this PPA during such hour;

“C” = the product of (x) the number of MWh of energy purchased by Company with respect to such hour, to replace the Expected Facility

Output that was not delivered under this PPA, and (y) the actual cost of registered RECs for that number of MWh, for such hour;

“D” = the actual cost of transmission, ancillary services, fuel and fuel transportation, other incremental costs, and any related penalties that could not be avoided or mitigated, and transaction charges to deliver reasonably available energy to Company in amounts equal to the number of MWh for which Replacement Power Costs are owed; and

“E” = the sum of all payments avoided by Company as a result of Seller’s breach, for such hour, including avoided payments under Article 8.

“ROFO” and “ROFO Notice” shall have the meanings set forth in Section 19.3.

“SCADA” means supervisory control and data acquisition.

“Scheduled Termination Date” shall have the meaning set forth in Article 2.

“Security Fund” shall have the meaning set forth in Section 11.1.

“Seller Excuse Hours” means those hours during which Seller is unable to schedule or deliver Renewable Energy to Company as a result of (A) Non-Compensable Curtailments; (B) Force Majeure; (C) a Transformer Failure; or (D) Company’s failure to perform.

“Site” means, with respect to the Project, the parcels of real property on which each of the Phase I and Phase II components of the Facility will be located, including any easements, rights of way, surface use agreements and other interests or rights in real estate necessary for the construction, operation and maintenance of the Facility. The Site is more specifically described in Exhibit C - Facility Description to this PPA.

“State Regulatory Agency” means the Public Utility Commission of Texas and/or the New Mexico Public Regulation Commission, or any successor agencies.

“State Regulatory Approval” means a written initial order of the State Regulatory Agency approving this PPA in such a manner that all costs incurred by Company under this PPA will be recoverable from retail customers in a timely manner through fuel clauses and, if applicable, base rates pursuant to Applicable Law subject only to the requirement that the State Regulatory Agency retain ongoing prudence review of Company’s performance and administration of this PPA.

“Step-In Rights” shall have the meaning set forth in Section 12.5.

“Substation” means the substation at which the Point of Delivery is located for each of the Phase I and Phase II components of the Facility, as depicted in Exhibit C – Facility Description.

“Target COD” shall have the meaning set forth in Section 4.5(A).

“Term” means the period of time during which this PPA remains in full force and effect, as further defined in Article 2.

“Test Energy” shall have the meaning set forth in Section 4.6.

“Transformer Failure” means a failure for any cause to all or part of the high voltage equipment including the transformer, the associated circuit breakers and any and all other high voltage switchgear and associated equipment; *provided*, any such failure cannot exceed one year in duration.

“Transmission Authority” means collectively those entities owning and/or operating the interconnected transmission system applicable to Seller and the Facility pursuant to a Transmission Tariff, including (i) Southwest Power Pool, Inc., or its successor as to any function, operating under and in accordance with its Transmission Tariff, and (ii) all entity(s) responsible under the Interconnection Agreement for providing the transmission lines, any Interconnection Facilities and other equipment and facilities with which the Facility interconnects at the Interconnection Point and transmission system.

“Transmission Authority’s System” means the contiguously interconnected electric transmission and sub-transmission facilities, over which the Transmission Authority has rights (by ownership or contract) to provide bulk transmission of capacity and energy from the Interconnection Point.

“Transmission Delay”, shall have the meaning set forth in Section 4.5(A)(2).

“Transmission Tariff” means the applicable Open Access Transmission Tariff of the Transmission Authority, as amended from time to time.

“Wind Turbine(s)” means the wind-energy generating devices that are included in the Facility. The manufacturer and model number of the Wind Turbines is identified on Exhibit C – Facility Description.

\* \* \* \* \*

**EXHIBIT B**

**CONSTRUCTION MILESTONES**

**PHASE I CONSTRUCTION MILESTONES**

<b>Milestone</b>	<b>Outcome</b>
Completed	Seller shall have achieved closing on financing for the Facility or provided Company with proof of financial capability to construct the Facility.
Completed	Seller and the Transmission Authority shall have executed the Interconnection Agreement.
6/30/2018	Seller and all required counterparties shall have executed such Construction Contracts as are needed to construct the Facility.
10/30/2018	Seller shall have laid the foundation for all Facility buildings, generating facilities and step-up transformation facilities.
11/30/2018	The Wind Turbines and step-up transformer shall have been delivered and installed at the Site.
11/30/2018	Seller's Interconnection Facilities shall have been constructed, and such facilities are capable of being energized.
12/1/2018	Start-up testing of the Facility commences.

**PHASE II CONSTRUCTION MILESTONES**

<b>Milestone</b>	<b>Outcome</b>
Completed	Seller shall have achieved closing on financing for the Facility or provided Company with proof of financial capability to construct the Facility.
2/1/2018	Seller and the Transmission Authority shall have executed the Interconnection Agreement.
6/15/2018	Seller and all required counterparties shall have executed such Construction Contracts as are needed to construct the Facility.
10/15/2018	Seller shall have laid the foundation for all Facility buildings, generating facilities and step-up transformation facilities.
11/30/2018	The Wind Turbines and step-up transformer shall have been delivered and installed at the Site.
11/30/2018	Seller's Interconnection Facilities shall have been constructed, and such facilities are capable of being energized.
12/1/2018	Start-up testing of the Facility commences.

## EXHIBIT C

### FACILITY DESCRIPTION AND SITE MAPS

The Facility shall be located on the Site and shall be identified as Seller's Bonita Winds Generation Facility. Maps and one-line diagrams of the Facility, the Lorenzo Project, the Wildcat Project and associated equipment are included as part of this Exhibit.

The address of Phase I of the Facility is County Road 125, Crosbyton, TX 79322.

The address of Phase II of the Facility is County Road 117, Morton, TX 79346.

The Facility includes the following specific components:

- \* 12 safe harbored GE 1.715 MW 103m Rotor Diameter / 80m Hub Height turbines and 91 GE 2.3 MW 116m Rotor Diameter / 90m Hub Height turbines;
- \* panel space and 125VDC battery supplied voltage necessary to accommodate the metering, telemetering and communications equipment required by the PPA;
- \* communication circuits from the Facility to the EMCC for the purpose of telemetering, supervisory control/data acquisition, and voice communications as required by Company;
- \* equipment and software necessary to receive, accept and react to an AGC signal from the Company's SCADA System and to comply with the AGC Protocols as further specified on Exhibit I - AGC Protocols; Data Collection; Technical Specifications;
- \* each Wind Turbine to be equipped with meteorological measurement equipment (e.g. anemometers), individually linked to Seller's information system;
- \* the capability of sending real time data and OPC interface to Company's PI System; and
- \* all equipment required to meet FERC Order Number 827 for Reactive Power Requirements for Non-Synchronous Generation.

Site Maps

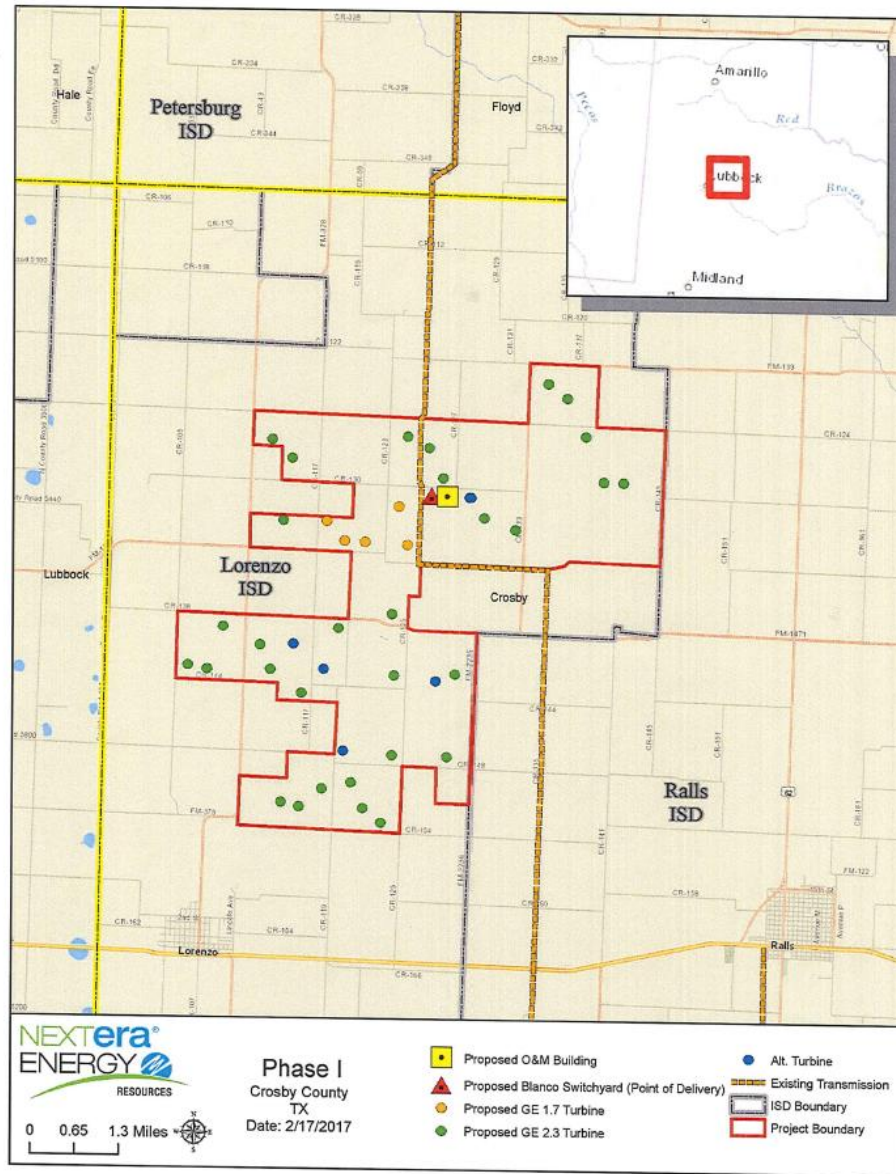

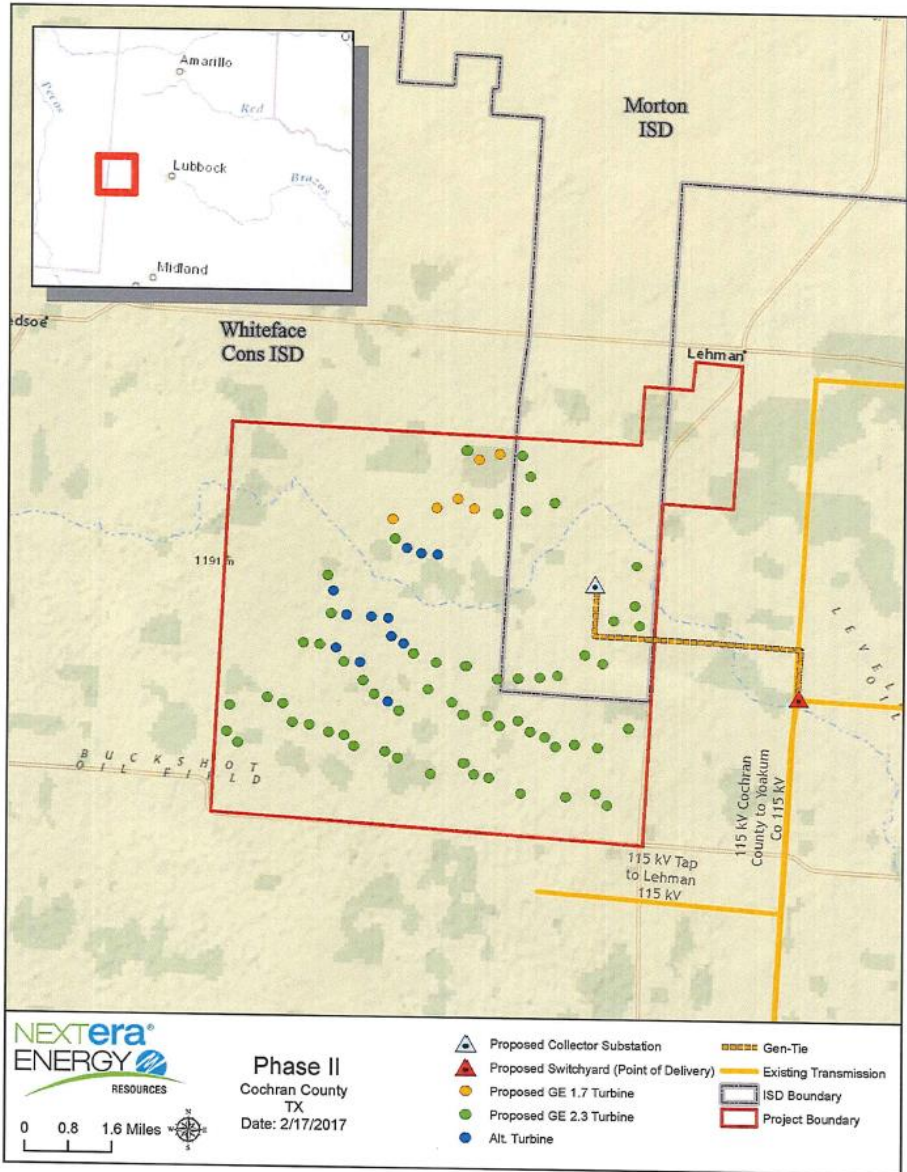

One Line Diagram

Phase I One-Line Diagram

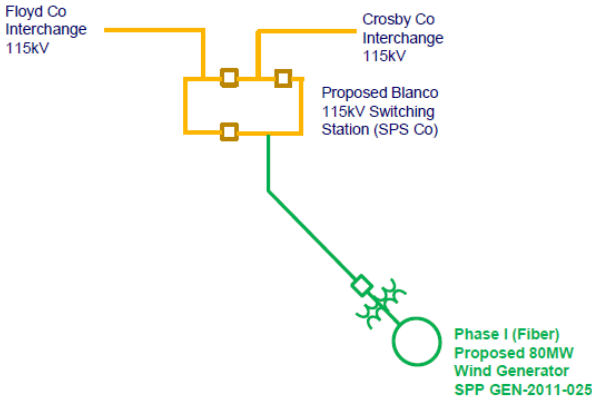



### Phase II One-Line Diagram

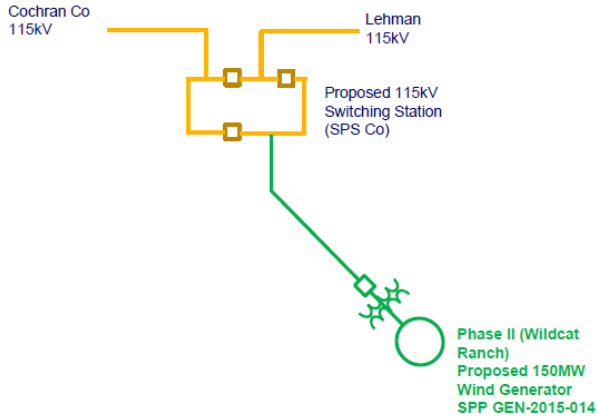

2



**EXHIBIT D**

**NOTICES AND CONTACT INFORMATION**

<u><b>Company</b></u>	<u><b>Seller</b></u>
<p><b>Notices:</b>  <u>Tara Fowler</u>  Renewable Purchased Power Manager  Xcel Energy Services Inc.  1800 Larimer Street, Suite <u>1000</u>  Denver, CO 80202</p> <p><i>with a cc to:</i>  <u>Bruce Hallett</u>  Purchased Power Analyst  Xcel Energy Services Inc.  1800 Larimer Street, Suite 1000  Denver, CO 80202</p>	<p><b>Notices:</b>  Bonita Wind Energy, LLC  700 Universe Blvd.  Juno Beach, FL 33408 - 0420  Attention: Megan Kiernan  Phone: (561) 304-5566</p> <p><i>with a cc to:</i>  Bonita Wind Energy, LLC  700 Universe Blvd.  Juno Beach, FL 33408 - 0420  Attention: Associate General Counsel  Phone: (561) 304-5220</p>
<p><b>Operating Committee Representative:</b>  <u>Tara Fowler</u>  Renewable Purchased Power Manager  Xcel Energy Services Inc.  1800 Larimer Street, Suite 1000  Denver, CO 80202</p> <p><b>Alternate:</b>  <u>Bruce Hallett</u>  Purchased Power Analyst  Xcel Energy Services Inc.  1800 Larimer Street, Suite 1000  Denver, CO 80202</p>	<p><b>Operating Committee Representative:</b>  Bonita Wind Energy, LLC  700 Universe Blvd.  Juno Beach, FL 33408 - 0420  Attention: Megan Kiernan  Phone: (561) 304-5566</p> <p><b>Alternate:</b>  Bonita Wind Energy, LLC  700 Universe Blvd.  Juno Beach, FL 33408 - 0420 Attention:  Justin Fong  Phone: (561) 304-5685</p>
<p><b>Real-Time Contact Information</b>  <u>EMCC</u> (24 hour coverage):  Phone: 303-571-6280</p> <p><u>Transmission Ops:</u>  Phone:</p>	<p><b>Real-Time Contact Information</b>  Fleet Performance and Diagnostics Center (FPDC)</p> <p>Phone:(561) 694-3636 Toll  Free: (866)375-3737  Fax: (561) 694-3615</p>

**EXHIBIT E**

**INSURANCE COVERAGE**

Type of Insurance	Minimum Limits of Coverage
Commercial General Liability (CGL) and commercial umbrella	\$11,000,000 combined single limit each occurrence and the aggregate, where applicable. [If CGL insurance contains a general aggregate limit, it shall apply separately to the Facility].

CGL insurance shall be written on ISO occurrence form CG 00 01 01 96 (or a substitute form providing equivalent coverage) and shall cover liability arising from premises, operations, independent contractors, products/completed operations, contracts, property damage, personal injury and advertising injury, and liability assumed under an insured contract (including the tort liability of another assumed in a business contract), all with limits as specified above. CGL insurance shall include ISO endorsement CG 24 17 (or an equivalent endorsement) which modifies the definition of "Insured contract" to eliminate the exclusion of easement or license agreements in connection with construction or demolition operations on or within 50 feet of a railroad. There shall be no endorsement or modification of the CGL insurance limiting the scope of coverage for liability arising from explosion, collapse, or underground property damage.

Company shall be included as an insured under the CGL policy, using ISO additional insured endorsement CG 20 10 (or a substitute providing equivalent coverage), and under the commercial umbrella insurance. The commercial umbrella insurance shall provide coverage over the top of the CGL insurance, the Business Automobile Liability insurance, and the Employers Liability insurance. The CGL and commercial umbrella insurance to be obtained by or on behalf of Seller shall be endorsed as follows:

Such insurance as afforded by this policy for the benefit of Company shall be primary as respects any claims, losses, damages, expenses, or liabilities arising out of this PPA, and insured hereunder, and any insurance carried by Company shall be excess of and noncontributing with insurance afforded by this policy.

Business Automobile Liability	\$2,000,000 combined single limit (each accident), including all Owned, Non-Owned, Hired and Leased Autos.
-------------------------------	--

Business Automobile Liability insurance shall be written on ISO form CA 00 01, CA 00 05, CA 00 12, CA 00 20, or a substitute form providing equivalent liability coverage. If necessary, the policy shall be endorsed to provide contractual liability coverage equivalent to that provided in the 1990 and later editions of CA 00 01.

Workers Compensation	Statutory Requirements. Seller may comply with these requirements through the use of a qualified self-insurance plan.
----------------------	---

[Exhibit E - continued]

Type of Insurance	Minimum Limits of Coverage
-------------------	----------------------------

Employers Liability	\$2,000,000 each accident for bodily injury by accident, or \$2,000,000 each employee for bodily injury by disease.
---------------------	---

Builder's Risk	Probable Maximum Loss of the Facility.
----------------	--

Builder's Risk insurance, or an installation floater, shall include coverage for earthquake and flood, collapse, faulty workmanship, materials and design, testing of machinery or equipment, freezing or changes in temperature, debris removal, and partial occupancy.

Pollution Liability	\$5,000,000 each occurrence.
---------------------	------------------------------

All-Risk Property insurance covering physical loss or damage to the Facility	Probable Maximum Loss of the Facility. A deductible may be carried which deductible shall be the absolute responsibility of Seller.
--	---

All-Risk Property insurance shall include: (i) coverage for fire, flood, wind and storm, tornado and earthquake with respect to facilities similar in construction, location and occupancy to the Facility, with sublimits of no less than \$10,000,000 each for flood and earthquake; and (ii) Boiler and Machinery insurance covering all objects customarily subject to such insurance, including boilers and turbines, in an amount equal to their probable maximum loss.

Business Interruption insurance	Amount required to cover Seller's continuing or increased expenses, resulting from full interruption, for a period of 12 calendar months.
---------------------------------	---

Business Interruption insurance shall cover loss of revenues or the increased expense to resume operations attributable to the Facility by reason of total or partial suspension or delay of, or interruption in, the operation of the Facility as a result of an insured peril covered under Property insurance as set forth above, to the extent available on Commercially Reasonable terms as determined by Company, subject to a Commercially Reasonable deductible that shall be the responsibility of Seller. Notwithstanding any other provision of this PPA, Seller shall not be required to have Business Interruption insurance until the Commercial Operation Date.

**EXHIBIT F**  
**SELLER'S NEEDED PERMITS**

<u>Agency</u>	<u>Permit Required</u>
Federal Aviation Administration	Determination of No Hazard
Federal Energy Regulatory Commission	Market-Based Rate Authorization
Cochran and Crosby County	Approval for Work in County Right-of-Way
Texas Department of Transportation	Road Entrance
Texas Department of Transportation	Driveway Permit
Texas Department of Transportation	Utility Permit
Texas Department of Transportation	Highway Access and Crossing Permits
Texas Department of Transportation	Oversized and/or Overweight Permit

## EXHIBIT G

### FORM OF LETTER OF CREDIT

[LETTERHEAD OF ISSUING BANK]

Irrevocable Standby Letter of Credit      Date of Issuance: \_\_\_\_\_  
No: \_\_\_\_\_

Beneficiary: [ OpCo ]

Initial Expiration Date: [Must be at least  
one year after date of issuance]

Applicant:

As the Issuing Bank ("Issuer"), we, [Name of Issuing Bank], hereby establish this irrevocable Standby Letter of Credit No. \_\_\_\_\_ (this "Letter of Credit") in favor of the above-named beneficiary ("Beneficiary") for the account of the above-named applicant ("Applicant") in the amount of US\$\_\_\_\_\_ (\_\_\_\_\_ Million U.S. Dollars).

Beneficiary may draw all or any portion of this Letter of Credit at any time and from time to time, and Issuer will make funds immediately available to Beneficiary upon presentation of Beneficiary's draft(s) at sight in substantially the form attached hereto as Exhibit "A" ("Draft Certificate and Sight Draft"), drawn on Issuer and accompanied by this Letter of Credit. All Draft Certificates and Sight Drafts must be signed on behalf of Beneficiary, and the signatory must indicate his or her title or other official capacity. No other documents will be required to be presented. Issuer will effect payment under this Letter of Credit within the next banking day after presentment of any Draft Certificate and Sight Draft. Payment shall be made in U.S. Dollars with Issuer's own funds in immediately available funds.

Issuer will honor any Draft Certificate and Sight Draft presented in substantial compliance with the terms of this Letter of Credit at the Issuer's letterhead office, the office located at \_\_\_\_\_ or any other full service office of the Issuer on or before the above-stated expiration date, as such expiration date may be extended hereunder. Partial and multiple draws and presentations are permitted on any number of occasions. Following any partial draw, Issuer will endorse this Letter of Credit and return the original to Beneficiary.

This Letter of Credit is issued pursuant to the provisions of that certain [Wind] [Solar] Energy Purchase Agreement between Beneficiary and Applicant dated as of \_\_\_\_\_, 20\_\_ (as the same may have been or may be amended from time to time, the "PPA"). Notwithstanding any reference in this Letter of Credit to the PPA or any other documents, instruments or agreements, or references in the PPA or any other documents, instruments or agreements to this Letter of Credit, this Letter of Credit contains the entire agreement between Beneficiary and Issuer relating to the obligations of Issuer hereunder.

This Letter of Credit will be automatically extended each year without amendment for a period of one (1) year from the expiration date hereof, as extended, unless at least thirty (30) days prior to the expiration date, Issuer notifies Beneficiary by registered or certified mail that it elects not to extend this Letter of Credit for such additional period. Notice of non-extension will be given by Issuer to Beneficiary at Beneficiary's address set forth herein or at such other address as Beneficiary may designate to Issuer in writing at Issuer's letterhead address.

This Letter of Credit is freely transferable by Beneficiary in whole or in part, and the number of transfers is unlimited. Issuer shall effect any transfers immediately upon presentation to Issuer of this Letter of Credit and a completed written transfer request substantially in the form attached hereto as Exhibit "B." Any transfer fees assessed by Issuer will be payable solely by Beneficiary.

Issuer waives any rights it may have, at law or otherwise, to subrogate to any claims which Beneficiary may have against Applicant or Applicant may have against Beneficiary.

This Letter of Credit is subject to the uniform customs and practice for documentary credits (2007 Revision), International Chamber of Commerce publication No. 600 (the "UCP"), except to the extent that the terms hereof are inconsistent with the provisions of the UCP, including but not limited to Articles 14(b) and 36 of the UCP, in which case the terms of this Letter of Credit shall govern. With respect to Article 14(b) of the UCP, Issuer shall have a reasonable amount of time, not to exceed three (3) banking days following the date of Issuer's receipt of documents from Beneficiary (to the extent required herein), to examine the documents and determine whether to take up or refuse the documents and to inform Beneficiary accordingly.

In the event of an act of God, riot, civil commotion, insurrection, war or any other cause beyond Issuer's control that interrupts Issuer's business and causes the place for presentation of this Letter of Credit to be closed for business on the last day for presentation, the expiry date of this Letter of Credit will be automatically extended without amendment to a date thirty (30) calendar days after the place for presentation reopens for business.

ISSUER:

By: \_\_\_\_\_  
Authorized Signature

**EXHIBIT "A"**  
TO LETTER OF CREDIT

**DRAFT CERTIFICATE AND SIGHT DRAFT**

The Beneficiary is entitled to draw under the Letter of Credit an amount equal to \$\_\_\_\_\_, for the following reason [check applicable provision]:

[ ]A. Beneficiary is entitled to draw pursuant to section [ ] of that certain PPA between Beneficiary and Applicant dated as of \_\_\_\_\_, 20\_\_ (as the same may have been or may be amended from time to time, the "PPA").

[ ]B. The Letter of Credit will expire in fewer than 30 days from the date hereof, and Applicant has not provided to Beneficiary alternate security (as allowed under the PPA).

Draft Number \_\_\_\_\_  
\$ \_\_\_\_\_

At sight, pay to the order of [Name of Beneficiary to be inserted], the amount of USD \$\_\_\_\_\_ (\_\_\_\_\_ and 00/100ths U.S. Dollars).

Value received and charged to the account of: [Name of Issuer and address].  
Drawn under [Name of Issuer to be inserted] Standby Letter of Credit No.  
\_\_\_\_\_.

Dated: \_\_\_\_\_

[OpCo]

By: \_\_\_\_\_  
[name and title]

Account: [Applicant to be inserted]



**EXHIBIT "B"**  
TO LETTER OF CREDIT

**FORM OF TRANSFER REQUEST**

Irrevocable Standby Letter of Credit No. \_\_\_\_\_

Current Beneficiary:

Applicant:

\_\_\_\_\_  
\_\_\_\_\_  
\_\_\_\_\_

\_\_\_\_\_  
\_\_\_\_\_  
\_\_\_\_\_

To: [Name of Issuer] ("Issuer")

The undersigned, as the current "Beneficiary" of the above-referenced Letter of Credit, hereby requests that you reissue the Letter of Credit in favor of the transferee named below [insert transferee name and address below]:

\_\_\_\_\_  
\_\_\_\_\_  
\_\_\_\_\_

From and after the date this transfer request is delivered to Issuer, the transferee shall be the "Beneficiary" under the Letter of Credit for all purposes and shall be entitled to exercise and enjoy all of the rights, privileges and benefits thereof.

Dated: \_\_\_\_\_

[OpCo]

By: \_\_\_\_\_

Name: \_\_\_\_\_

Title: \_\_\_\_\_

[Notary Acknowledgement]

To be signed by a person purporting to be an authorized representative of Beneficiary and indicating his or her title or other official capacity, and acknowledged by a notary public.

**EXHIBIT H**  
**FORM OF GUARANTY**

**GUARANTY**

This Guaranty is executed and delivered as of this \_\_\_\_ day of \_\_\_\_\_, 20\_\_ by \_\_\_\_\_, a \_\_\_\_\_ [corporation] ("Guarantor"), in favor of [OpCo] ("Company"), in connection with the performance by \_\_\_\_\_, a \_\_\_\_\_ [limited liability company] ("Seller") of a [Wind] [Solar] Energy Purchase Agreement dated \_\_\_\_\_, 20\_\_ between Seller and Company (the "PPA").

- RECITALS -

A. Seller owns and operates a [wind] [solar] power electric generation facility having total nameplate capacity of approximately \_\_\_\_ MW located in \_\_\_\_\_ County, \_\_\_\_\_ (the "Facility").

B. Seller and Company have entered into the PPA for the purchase and sale of capacity and electrical energy from the Facility on the terms and conditions set forth therein.

C. Seller is a direct or indirect, wholly owned subsidiary of Guarantor. Guarantor expects to derive substantial benefits from the performance of the PPA by Seller and Company. To induce Company to enter into and continue the PPA and to consummate the purchase and sale of electrical energy contemplated by the PPA, Guarantor has agreed to guarantee the obligations of Seller as provided in this Guaranty.

NOW, THEREFORE, in consideration of the foregoing, Guarantor agrees as follows:

- AGREEMENT -

1. Guaranty. Subject to the provisions of this Guaranty, Guarantor hereby absolutely, irrevocably, unconditionally, and fully guarantees to Company the due, prompt, and complete observance, performance, and discharge of each and every payment obligation of Seller under the PPA, whether incurred before or after the date of delivery of this Guaranty (the "Obligations"). This is a guaranty of payment, not of collection, and as such, Company shall not be required to institute, pursue, or exhaust any remedies against Seller before instituting suit, obtaining judgment, and executing thereon against Guarantor under this Guaranty.

2. Maximum Liability. Notwithstanding anything herein to the contrary, Guarantor's maximum liability under this Guaranty shall be limited to twenty-eight million, five-hundred thousand dollars (US\$28,500,000), *plus* one million dollars (US\$1,000,000) for the costs of collection with respect to any valid claim(s) made by

Company hereunder that are incurred in the enforcement or protection of the rights of the Company; *provided*, Guarantor shall not be liable for such fees and expenses of Counterparty under this Section 2 if it is finally determined by a court of competent jurisdiction that no payment under this Guaranty is due.

3. Rights of Company. Guarantor hereby grants to Company, in Company's discretion and without the need to notify or obtain any consent from Guarantor, and without termination, impairment, or any other effect upon Guarantor's duties hereunder, the power and authority from time to time:

(a) to renew, compromise, extend, accelerate, or otherwise change, substitute, supersede, or terminate the terms of performance of any of the Obligations, in each case in accordance with the PPA;

(b) to grant any indulgences, forbearances, and waivers, on one or more occasions, for any length of time, with respect to Seller's performance of any of the Obligations; and

(c) to accept collateral, further guaranties, and/or other security for the Obligations, and, if so accepted, then to impair, exhaust, exchange, enforce, waive, or release any such security.

4. Performance. If any of the Obligations are not performed according to the tenor thereof, and any applicable notice and cure period provided by the PPA has expired ("Default"), Guarantor shall promptly upon receipt of written demand by Company (a) perform or cause Seller to perform the Obligation in Default, and (b) pay, reimburse, and indemnify Company against any liabilities, damages, and related costs (including attorneys' fees) incurred by Company as a result thereof, all in such manner and at such times as Company may reasonably direct.

5. Satisfaction. Satisfaction by Guarantor of any duty hereunder incident to a particular Default or the occurrence of any other Default shall not discharge Guarantor except with respect to the Default satisfied, it being the intent of Guarantor that this Guaranty be continuing until the earlier of: (1) such time as all of the Obligations have irrevocably been discharged in full, (2) the 30<sup>th</sup> anniversary of this Guaranty (*provided* that Guarantor's liability with respect to Obligations incurred prior to such date shall not terminate) or (3) such time as the Seller has provided an alternate form of Security Fund (as defined in the PPA) under Article 11 of the PPA in substitution for this Guaranty, it being understood that Guarantor shall not be released hereunder prior to the full discharge of the Obligations unless such alternate Security Fund has been deposited, at which time this Guaranty shall automatically terminate. If at any time the performance of any Obligation by Seller or Guarantor is rescinded or voided under the federal Bankruptcy Code or otherwise, then Guarantor's duties hereunder shall continue and be deemed to have been automatically reinstated, restored, and continued with respect to that Obligation, as though the performance of that Obligation had never occurred, regardless of whether this Guaranty otherwise had terminated or would have been terminated following or as a result of that performance.

6. Notice of Acceptance. Guarantor waives and acknowledges notice of acceptance of this Guaranty by Company.

7. Waivers by Guarantor. Guarantor hereby waives and agrees not to assert or take advantage of:

(a) all set-offs, counterclaims, and, subject to Section 4 above, all presentments, demands for performance, notices of non-performance, protests, and notices of every kind that may be required by Applicable Laws;

(b) any right to require Company to proceed against Seller or any other person, or to require Company first to exhaust any remedies against Seller or any other person, before proceeding against Guarantor hereunder;

(c) any defense based upon an election of remedies by Company;

(d) any duty of Company to protect or not impair any security for the Obligations;

(e) the benefit of any laws limiting the liability of a surety, subject to Section 16 below;

(f) any duty of Company to disclose to Guarantor any facts concerning Seller, the PPA or the Facility, or any other circumstances, that would or allegedly would increase the risk to Guarantor under this Guaranty, whether now known or hereafter learned by Company, it being understood that Guarantor is capable of and assumes the responsibility for being and remaining informed as to all such facts and circumstances; and

(g) until all Obligations in Default have been fully paid and/or performed, any rights of subrogation, contribution, reimbursement, indemnification, or other rights of payment or recovery for any payment or performance by it hereunder. For the avoidance of doubt, if any amount is paid to Guarantor in violation of this provision, such amount shall be held by Guarantor for the benefit of, and promptly paid to, Company.

8. Cumulative Remedies. The rights and remedies of Company hereunder shall be cumulative and not alternative to any other rights, powers, and remedies that Company may have at law, in equity, or under the PPA. The obligations of Guarantor hereunder are independent of those of Seller and shall survive unaffected by the bankruptcy of Seller. Company need not join Seller in any action against Guarantor to preserve its rights set forth herein.

9. Representations and Warranties. Guarantor represents and warrants to Company as follows:

(a) Guarantor is a corporation, duly organized, validly existing, and in good standing under the laws of the state of its incorporation. Seller is a direct or

indirect wholly-owned subsidiary of Guarantor. Guarantor has all necessary corporate power and authority to execute and deliver this Guaranty and to perform its obligations hereunder.

(b) The execution, delivery and performance of this Guaranty has been duly and validly authorized by all corporate proceedings of Guarantor and is not in violation of any law, judgment of court or government agency. This Guaranty has been duly and validly executed and delivered by Guarantor and constitutes a legal, valid and binding obligation of Guarantor, enforceable against Guarantor in accordance with its terms, except as the enforceability thereof may be limited by the effect of any applicable bankruptcy, insolvency, reorganization, moratorium or similar laws affecting creditors' rights generally and by general principles of equity.

10. Collection Costs. Subject to Section 2 hereof, Guarantor hereby agrees to pay to Company, upon demand, and in addition to the maximum liability set forth in Section 2 hereof, all reasonable and actual attorneys' fees and other expenses which Company may expend or incur in enforcing the Obligations against Seller and/or enforcing this Guaranty against Guarantor, whether or not suit is filed, including, without limitation, all attorneys' fees, and other expenses incurred by Company in connection with any insolvency, bankruptcy, reorganization, arrangement, or other similar proceedings involving Seller that in any way affect the exercise by Company of its rights and remedies hereunder.

11. Severability. Should any one or more provisions of this Guaranty be determined to be illegal or unenforceable, all other provisions nevertheless shall be effective.

12. Waiver or Amendment. No provision of this Guaranty or right of Company hereunder can be waived, nor can Guarantor be released from Guarantor's duties hereunder, except by a writing duly executed by Company. This Guaranty may not be modified, amended, revised, revoked, terminated, changed, or varied in any way whatsoever except by the express terms of a writing duly executed by Company.

13. Successors and Assigns. This Guaranty shall inure to the benefit of and bind the successors and assigns of Company and Guarantor.

14. Governing Law. This Guaranty shall be governed by and construed in accordance with the law of the State of New York without regard to the principles of conflicts of law thereof (other than Section 5-1401 of the New York General Obligations Law).

15. Notices. All notices, requests, claims, demands, and other communications hereunder shall be in writing and shall be given (and shall be deemed to have been duly given upon receipt) by delivery in the manner contemplated by the PPA, addressed as follows:

(a) if to Company: as provided in the PPA

(b) if to Guarantor. \_\_\_\_\_  
\_\_\_\_\_

Attn:

with a copy to: \_\_\_\_\_  
\_\_\_\_\_

Attn:

or to such other address(es) as the person to whom notice is given may have previously furnished to the others in writing in the manner set forth above.

16. Reservation of Certain Seller Defenses. Notwithstanding anything in this Guaranty to the contrary, Guarantor reserves to itself all rights, and defenses, in each case raised in good faith, to which Seller is or may be entitled arising from or out of the Agreement, except for defenses (if any) based upon the bankruptcy, insolvency, illegality, dissolution or liquidation of Seller or any lack of power or authority of Seller to enter into and/or perform the Agreement.

IN WITNESS WHEREOF, Guarantor has caused this Guaranty to be duly executed and delivered to Company as of the day and year first above written.

**[Name of Guarantor]**

By: \_\_\_\_\_  
Name:  
Title:

STATE OF \_\_\_\_\_ )  
) ss.  
COUNTY OF \_\_\_\_\_ )

The foregoing instrument was acknowledged before me this \_\_\_\_\_ day of \_\_\_\_\_, 20\_\_\_\_, by \_\_\_\_\_, as \_\_\_\_\_ of \_\_\_\_\_.

Witness my hand and official seal.

My commission expires: \_\_\_\_\_.

( S E A L )

\_\_\_\_\_  
Notary Public

## EXHIBIT I

### AGC PROTOCOLS; DATA COLLECTION; TECHNICAL SPECIFICATIONS

#### AGC

#### 1. AGC Communications between Company and Seller

Company will receive and send AGC Set-Point and related data over an analog or digital line. The data points covered under this PPA, as described below, may overlap data requirements for the Transmission Authority or Company's applicable forecasting group.

#### 2. AGC Data Points to be sent from Seller to Company via SCADA

The following data points will be transmitted via SCADA from Seller to Company and represent Facility level data:

<u>Description</u>	<u>Units</u>
AGC Set-Point (echo)	MW
Power demand	MW
Actual power	MW
Park Potential	MW
Actual reactive power	Mvars
Average Voltage	kV
Number of turbines online and running	Integer
AGC Status	Remote/Local

#### 3. Response times and limitations of Facility in regards to AGC

The following protocols outline the expectations for responding to the AGC Set-Point. Except in the case of the Frequency of Changes, these protocols will be generally bound by the manufacturers' specifications for the equipment that Seller has chosen for the Facility.

a. Allowable Variances in Excess of AGC Set-Point. Once the Facility has reached the AGC Set-Point, there may be variances in excess of such set-point up to 2% on average as measured during a 10-minute period. This is due to changing wind conditions vs. the manufacturer's specifications for responding to those new conditions.

b. Frequency of Changes. Company may send a new AGC Set-Point to the Facility as frequently as the Wind Turbine manufacturer specifications allow.

c. Range of AGC Set-Point. The range of set point values can be between 0% and 100% of Park Potential.

#### **4. Backup Communications**

In the event of an AGC failure, Company and Seller shall communicate via telephone in order to correct the failure.

### **DATA COLLECTION**

#### **1. Data**

At least two months prior to the Commercial Operation Date, Seller will deliver to Company a report showing (i) manufacturer, model, and year of all Wind Turbines and meteorological instrumentation and (ii) the latitude, longitude and hub height at every Wind Turbine and meteorological tower.

Beginning upon COD, Seller shall transmit and provide to Company the real-time data set forth below, refreshed in approximately four-ten (4-10) second intervals with regard to its generation of Renewable Energy at the Facility:

a. Five data points from each Wind Turbine:

1. Turbine generation (kW)
2. Wind Speed (meters per second - mps)
3. Turbine Availability
4. A calculation of Wind Direction (in degrees relative to true north)
5. Temperature (Celsius)

b. Four data points from each Meteorological Tower:

1. Wind Speed\*\* (mps)
2. Wind Direction\*\* (degrees relative to true north)
3. Temperature (Celsius)
4. Pressure (mb)

\*\* = at all metered heights.

c. In addition to the other requirements for data collection, Seller shall install, maintain and operate industry approved remote sensing technologies. The data stream from such sensing technologies to the Company's PI System must be reliable during periods of transmission-related curtailments and must include battery back-up at the meteorological tower and a local source of electricity to power the PI System and interconnectivity between the Facility and Company during transmission outages.

d. Seller shall provide a map and key for each Wind Turbine sufficient to allow Company to correlate the data received through the PI System to each individual Wind Turbine.



## 2. Forecasting Requirements

a. The forecast shall be posted by 5 am every day and shall be applicable through the end of the next day. For example, at 5 am on Monday, an availability forecast is required for Tuesday (midnight to midnight). On Tuesday, the forecast for Wednesday, Wednesday for Thursday, and so on. The forecast shall be submitted through an availability forecast system as specified by Company to Seller. Prior to the Commercial Operation Date, Company shall provide Seller with information necessary for Seller to access the chosen availability forecast system.

b. If any events or circumstances reduce the forecasted availability of the Facility by 5 MW or more, such reduction shall be (1) communicated to the real-time operator via telephone with (2) immediate update to the availability forecast in the availability forecast system. For example:

i. A disturbance at a 100.5 MW (67 x 1.5 MW wind turbines) wind plant causes 26 wind turbines (39 MW) to become unavailable. Only two turbines were planned to be down for maintenance (3 MW). The expected reduction in the available capacity is 39 MW; exceeding the 5 MW requirement. A phone call to real-time operations with immediate update of the availability forecast is required. At the time of the outage, the estimated expected duration was thought to be six hours. Three hours into the outage, it became known that the 26 turbines would be available in an hour. A phone call notifying real-time of the change in availability is required with a coincident update in the availability forecast system.

ii. A disturbance at a 10 MW (8 x 1.25 MW turbines) wind plant forces 4 turbines (5 MW) off-line. Because the disturbance equals 5 MW, a phone call to real-time operations with immediate update of the availability forecast is required. If the disturbance had only affected 3 turbines (3.75MW), then no immediate action would be necessary.

iii. A 20 MW (20 x 1 MW turbines) wind plant is off-line for transmission maintenance. The maintenance work is completed 2 hours ahead of the projected completion. Because the change is greater than 10 MW, prior to coming on-line, a phone call is required coincident with an update to the availability forecast system to indicate the new availability.

## **SURFACE WEATHER SYSTEM TECHNICAL SPECIFICATIONS**

The Surface Weather System shall satisfy the following technical specifications, all at Seller's cost:

### Vaisala Hydromet System AWS301 (Quantity: 1)

- Data Collection and Processing System (DCP)
- AWS base unit w/ QML201C logger and BOX652 enclosure for DCP with Installation Frame and Radiation Shield

- Basic 24VDC main power supply
- Extra 24VDC main power supply
- Interface for 2x12V/26Ah Internal Batteries
- BAR0-1QML press. sensor Class A calibration
- PWD22 heated 3.85m cable + mounting
- QMD202 display and keypad inside enclosure
- Standard AWS310 configuration for data collection unit with non-metric (US) units
- Wall/H Frame installation kit
- Rubber enclosure flanges Option
- TERMBOX-1212 option
- MCC301 Observation Software (Standard)
- RS-232 Maintenance Cable for DCP
- Removable CF Card 2 GB for DCP with Industrial Temperature Range (2 pcs)
- RS-485 (2-w) Interface with DCP with Connector, Wiring and Surge Protector Using COM 1
- DSI486 Dual RS-485 Module for DCP (2 x RS-485 (2-w) + 1 x SDI-12) DSI486 Dual RS-485 Module for DCP (2 x RS-485 (2-w) + 1 x SDI-12)
- Sensor Interface for DCP with Connector and Wiring to one (1) HMP155 Air Temperature and Relative Humidity Sensor, Heated RH, via RS-485 (2-w) using mod 2 DSI486 port 2
- Sensor Interface for DCP Surge Protection, Connectors and Wiring to one (1) WMT702 Ultrasonic Wind Sensor (Heated) via RS-485 (2-w). ADC40V60 req. using mod 1 DSI486 port 2
- Sensor Interface for DCP Surge Protection, Connectors and Wiring to one (1) WMT702 Ultrasonic Wind Sensor (Heated) via RS-485 (2-w). ADC40V60 req. using mod 2 DSI486 port 2

#### Backup Batteries (Quantity: 1)

- Battery 12V 26Ah

#### LCD Display & Keyboard Unit (Quantity: 1)

- Display/Keyboard for MAWS Enclosure Door

#### Hub Height Level Sensors/ 1 RHAT & 2 WIND - Air Temp, RH and Dew Point

- 1 x HMP155 Humidity and Temperature Probe, Heated RH (separate T and RH via RS485)
- 2 x WMT702 transd.+arms heat 10m cable + mast mount
- 1 x Radiation Shield for Humidity and Temperature Probe with Mounting Kit (installed on pole mast 60-100 mm)
- Cable, Extension M112 8N Female to Male, 3M (8-pin F-M connectors)

- Cable to connect sensor to WSP150, cut to length, plus connection from WSP150 to Termination Box
- Surge Protector — For Data and Power Wiring
- 2 x WMT702 transducers+ arms heated 10m cable + mast mount
  - Stainless Steel Enclosure
  - Heated transducers and arms
  - RS-485/RS-422/RS-232
  - Metric Setup
  - No Power Supply or Cable
  - No Mounting Adaptor
  - Basic Configuration Work
  - Manual
- Mounting Adaptor 30 mm
- RS-485 and Power Cable for MAWS/WMT702, 10M Cable to connect sensor to WSP150, cut to length, plus connection from WSP150 to Termination Box
- Surge Protector — For Data and Power Wiring
- 8' Retractable Boom w/Sensor Mount (Quantity: 2)
- 12 pair data cable, 22 gauge, open leads, Hub Height
- Termination Box with Mounting Kit (Hub Height), mounted at Hub Height Level
- 5 Conductor Power Cables, 16 gauge, open leads, Hub Height
- OPTIONAL Ice Condition Monitoring : PWD22 heated 3.85m cable + mounting

#### Extended Warranty

- Extended Warranty for up to four (4) years

Additionally, the installation of the Vaisala Surface Weather System shall require the following services: Configuration Work, Site Survey, Instrument Installation Day on Site-Vaisala, and Project Engineering/Management Work.

#### Reactive Power

[The Facility shall meet FERC Order Number 827 for Reactive Power Requirements for Non-Synchronous Generation].

\* \* \* \* \*

## EXHIBIT J

### ENERGY PAYMENT RATE

*This entire Exhibit shall be deemed Confidential Information subject to Section 20.18.*

Commercial Operation Year	Energy Payment Rate (\$/MWh)	Commercial Operation Year	Energy Payment Rate (\$/MWh)
1	\$18.10	16	\$24.36
2	\$18.46	17	\$24.85
3	\$18.83	18	\$25.34
4	\$19.21	19	\$25.85
5	\$19.59	20	\$26.37
6	\$19.98	21	\$26.90
7	\$20.38	22	\$27.43
8	\$20.79	23	\$27.98
9	\$21.21	24	\$28.54
10	\$21.63	25	\$29.11
11	\$22.06	26	\$29.69
12	\$22.51	27	\$30.29
13	\$22.96	28	\$30.89
14	\$23.41	29	\$31.51
15	\$23.88	30	\$32.14

## EXHIBIT K

### LENDER CONSENT PROVISIONS

In the event Seller seeks to enter into any Financing Document or collaterally assigns its rights hereunder to a Facility Lender as security, any related Lender Consent will contain provisions substantially as follows:

1. Seller and Company will neither modify nor terminate the PPA other than as provided herein, without the prior written consent of the Facility Lender.
2. The Facility Lender shall have the right, but no obligation, to do any act required to be performed by Seller under the PPA, and any such act performed by the Facility Lender shall be as effective to prevent or cure a default as if done by Seller itself.
3. If Company becomes entitled to terminate the PPA due to an uncured Event of Default by Seller, Company shall not terminate the PPA unless it has first given notice of such uncured Event of Default to the Facility Lender and has given the Facility Lender the same cure period afforded to Seller under Section 12.1 of the PPA, plus (a) an additional 30 Days beyond Seller's cure period to cure any monetary Event of Default, and (b) an additional 60 Days beyond Seller's cure period to cure any non-monetary Event of Default; *provided, however*, that if the Facility Lender requires possession of the Facility in order to cure the Event of Default, and if the Facility Lender diligently seeks possession, the Facility Lender's additional 30 Day or 60 Day cure period shall not begin until foreclosure is completed, a receiver is appointed, any bankruptcy stay is removed, or possession is otherwise obtained by or on behalf of the Facility Lender.
4. The Facility Lender shall provide to Company a copy of any notices of default and/or intent to exercise remedies delivered to Seller under the Financing Documents.
5. Neither the Facility Lender nor any other participant in the Facility Debt shall be obligated to perform or be liable for any obligation of Seller under the PPA until and unless any of them assumes the PPA through the exercise of the Facility Lender's rights and remedies.
6. Any party assuming the PPA through the exercise of the Facility Lender's rights and remedies shall remain subject to the terms of the PPA and shall (i) assume all of Seller's obligations under the PPA, (ii) cure any then-existing defaults capable of cure by performance or the payment of money damages, (iii) be, or contract with, a Qualified Operator; and (iv) enjoy (together with its parents and affiliates) an Investment Grade Credit Rating or other creditworthiness satisfactory to Company. In the event that the Facility Lender or its successor assumes the PPA in accordance with this paragraph 6, Company shall continue the PPA with the Facility Lender or its successor, as the case may be, substituted wholly in the place of Seller.
7. In the event that the Facility Lender or its successor assumes the PPA in accordance with paragraph 6, within 90 Days of any termination of the PPA as a result of rejection in any bankruptcy or insolvency proceeding, the Facility Lender (or its successor) and Company shall enter into a new power purchase agreement on the same terms and conditions as the PPA and for the period that would have been remaining under the PPA but for such termination.

## EXHIBIT L

### CURTAILMENT PROTOCOL

This Curtailment Protocol is applicable to the Wind Energy Purchase Agreement (“WEPA”) between Southwest Public Service Company and Bonita Wind Energy, LLC and addresses how the Company and Seller define, validate and administer the Non-Compensable Curtailment provisions of Section 8.3(B)(2)(i)-(viii) of the WEPA. Capitalized terms used herein but not otherwise defined shall have the meaning set forth in the WEPA. This Curtailment Protocol is not intended to amend, and will be construed in accordance with, the terms and conditions of the WEPA. In the event of a dispute between the Parties regarding the application of this Curtailment Protocol, such dispute will be resolved pursuant to Article XIII of the WEPA.

For the avoidance of doubt, curtailments of the Facility pursuant to the WEPA shall be implemented and administered with respect to each of the Phase I and Phase II components of the Facility separately. The determination of whether a curtailment is Compensable or Non-Compensable shall be based on which of the Phase I and Phase II components of the Facility(or both) has experienced a curtailment.

For purposes of making a Non-Compensable Curtailment Energy determination pursuant to the WEPA, the Parties agree to the following:

1. Section 8.3(B)(2)(a): *Emergency Condition*
  - a. Curtailment Information provided by the Transmission Authority will be used in determining whether a curtailment was the result of an Emergency.
2. Section 8.3(B)(2)(ii)(iii): *the restriction or reduction of firm or non-firm transmission service by the applicable transmission service provider*
  - a. Curtailments of the Company’s Firm Transmission Service for the Facility are Non-Compensable.
  - b. Curtailments of the Company’s transmission service for the Facility, other than the Company’s Firm Transmission Service, are Compensable.
  - c. Reliability instructions or directives from the Transmission Authority to reduce output from the Facility are:
    - i. Non-Compensable if Company has Firm Transmission Service for the Facility.
    - ii. Compensable if Company is utilizing transmission service for the Facility other than Firm Transmission Service.
3. Section 8.3(B)(2)(d): *maintenance outages of the transmission system*
  - a. Restrictions or reductions to the output of the Facility or Company’s transmission service arrangements under the circumstance(s) identified in

Section 8.3(B)(2)(iv) are Non-Compensable regardless of the level of the Company's transmission service. These restrictions or reductions are implemented by the Transmission Authority on an impact factor basis, without regard for the level of transmission service and are implemented when other actions available to the Transmission Authority are not sufficient to maintain acceptable flow limits on the transmission system. However, to the extent maintenance outages result in negative pricing rather than restrictions or reductions to the output of the Facility or Company's transmission arrangements, such outages are not covered by Section 8.3(B)(2) of the WEPA.

4. Parties shall use Curtailment Information in making a Non-Compensable Curtailment Energy determination. Company will include Curtailment Information sufficient to support any Non-Compensable Curtailment Energy determination in the billing parameter statement delivered to Seller.

"Curtailment Information" shall mean (i) Emergency Condition-related information, (ii) transmission service curtailment-related information, or (iii) maintenance outages or testing-related information, such Curtailment Information to be made available by the Transmission Authority to Company or Seller.

## EXHIBIT M

### MECHANICAL AVAILABILITY PERCENTAGE

For the avoidance of doubt, the Mechanical Availability Percentage for the Facility, including all related calculations, shall be determined on an aggregate and combined basis taking into account the availability of each of the Phase I and Phase II components of the Facility.

Section 1, Definitions.

Capitalized terms used in this Exhibit M and not defined herein shall have the meaning assigned in Exhibit A, Definitions of the PPA.

“Actual Availability Percentage” means, with respect to any given Availability Period, a percentage calculated as (a) 100, multiplied by (b) the result of (i) the sum of all Available Hours for all Wind Turbines that were part of the Facility at the beginning of such Availability Period, divided by (ii) the sum of all Period Hours in such Availability Period for all Wind Turbines that were part of the Facility at the beginning of the such Availability Period.

“Actual Facility Output” means the Energy (in MWh) generated by the Facility and delivered to the Point of Delivery.

“Aggregate Availability Damages Cap” has the meaning set forth in Section 2(3) of this Exhibit.

“Annual Availability Damages Cap” has the meaning set forth in Section 2(3) of this Exhibit.

“Annual Report” has the meaning set forth in Section 2(4) of this Exhibit.

“Availability Damages” has the meaning set forth in Section 2(2) of this Exhibit.

“Available Hours” means the portion of Period Hours, with respect to any given Wind Turbine, in which such Wind Turbine was electrically connected to the Interconnection Facilities. Available Hours are counted by a Wind Turbine’s programmable logic controller. Available Hours shall include all Excused Hours during which a Wind Turbine was not electrically connected to the Interconnection Facilities. Available Hours will also include the time during which a Wind Turbine is deliberately de-energized to optimize output from the Facility and the time required to return Wind Turbines to service after termination of any Seller Excuse Hours event. For the avoidance of doubt, Available Hours shall not include any scheduled maintenance hours.

“Availability Period” means each Calendar Year during the Term.



“Availability Termination” has the meaning set forth in Section 3(b) of this Exhibit.

“Cure” has the meaning set forth in Section 3(b) of this Exhibit.

“Expected Facility Output” means 1,029,563 MWhs per Calendar Year.

“Excused Hours” means during an Availability Period all (a) Seller Excuse Hours, and (b) other hours during which Company is unable for any reason (other than due to a breach by Seller of its obligations under this Agreement) to accept delivery of any Energy that the Facility is otherwise capable of producing.

“GMAP Default” has the meaning set forth in Section 2(3)(b) of this Exhibit.

“Guaranteed Mechanical Availability Percentage” has the meaning set forth in Section 2(1) of this Exhibit.

“Period Hours” means the sum total of hours for any given Availability Period.

“Unavailable Hours” means those hours a Wind Turbine is not available to operate because it is (a) in an emergency, stop, service mode or pause state (except to the extent that such emergency, stop, service mode or pause state also constitutes an Emergency); (b) in “run” status and faulted; (c) included in a scheduled maintenance outage; or (d) otherwise not operational or capable of delivering Energy to the Point of Delivery; *provided, however*, that notwithstanding the preceding, for purposes of determining Available Hours, a Wind Turbine shall be deemed to have been available to operate during hours in which it is not operating during Excused Hours.

“Unexcused Hours” means the positive difference, if any, calculated by subtracting Excused Hours from Unavailable Hours (e.g., 5,000 Unavailable Hours – 3,000 Excused Hours = 2,000 Unexcused Hours).

## Section 2, Availability Guarantee.

1. Availability Guarantee. Commencing on the first day of the second Commercial Operation Year and for the remainder of the Term, Seller guarantees that the Facility shall have achieved an Actual Availability Percentage during each Availability Period equal to or greater than 90% for the first 20 years and 85% for the remainder of the Term (a “Guaranteed Mechanical Availability Percentage”).

2. Availability Damages. For any Availability Period during which Seller fails to achieve the Guaranteed Mechanical Availability Percentage, Seller shall pay Company damages in the amount equal to (a) the Renewable Energy Payment Rate times, (b) the Guaranteed Mechanical Availability Percentage minus the Actual Availability Percentage for such Availability Period (both expressed as a decimal), multiplied by (c) the Expected Facility Output for such Availability Period (the “Availability Damages”), but in no event in excess of the Annual Availability Damages Cap and the Aggregate Availability Damages Cap. A sample calculation of the

Availability Damages that would be owed by Seller under certain stated assumptions is provided as Attachment 1 to this Exhibit M.

3. Damages Cap, GMAP Default.

(a) The total Availability Damages payable by Seller for failure to achieve the Guaranteed Mechanical Availability Percentage in any Availability Period shall be capped annually at \$989,000 ("Annual Availability Damages Cap") and in the aggregate at \$9,890,000 ("Aggregate Availability Damages Cap") over the Term of the PPA.

(b) If Seller (i) fails to achieve the Guaranteed Mechanical Availability Percentage in (A) three consecutive Availability Periods, or (B) four of six consecutive Availability Periods, or (ii) achieves an Actual Availability Percentage of less than 65% in any Availability Period (each a "GMAP Default"), then Company may terminate the PPA pursuant to Section 12.1(H)(10) of the PPA by providing written Notice to Seller within 30 days of delivery of the Annual Report reflecting the GMAP Default (an "Availability Termination"), *provided*, if the GMAP Default is related to (ii) above, then Seller may cure such failure by achieving the Guaranteed Mechanical Availability Percentage in the first Availability Period following the Availability Period in which the failure occurred (the "Cure"). If Seller fails to Cure, Company may terminate the PPA pursuant to an Availability Termination without any additional Cure Period.

4. Annual Report. At the beginning of the second Availability Period and at the beginning of each Availability Period thereafter, no later than the 30th Business Day of such Availability Period, Seller shall deliver to Company a calculation showing Seller's computation of the Actual Availability Percentage of the Facility for the previous Availability Period and the Availability Damages, if any, due to Company (the "Annual Report"). Such Annual Report shall include PI tags for the various turbine states and a key for the turbine states. Such Annual Report shall also include the total amount of Availability Damages paid to Company and shall provide notice that the Aggregate Availability Damages Cap has been reached, if applicable. If Availability Damages are due from Seller, Seller shall pay such damages no later than the 10th Business Day after providing the Annual Report; *provided*, if the Availability Damages are a negative number, the Availability Damages will be deemed to be zero dollars.

5. Disputes. Disputes as to any calculations under this Exhibit M shall be addressed as provided in Article 13 of the PPA.

**ATTACHMENT 1 TO EXHIBIT M  
EXAMPLE CALCULATION OF AVAILABILITY DAMAGES**

**I. Example of Availability Percentage Calculation (PASSED)**

The sample calculation set forth below is based on the following assumed facts:

During the Availability Period in question, 103 Wind Turbines had been completed and were part of the Facility, bringing the Facility Nameplate Capacity to 230 MW.

The Wind Turbines had the following operating characteristics:

	Hours	Wind Turbines Affected	Wind Turbine Hours
Period Hours ("PH")	8,760	103	902,280
Unavailable Hours ("FOH")			12,000
Excused Hours ("EH")			4,000
Unexcused Hours ("UH")			8,000

FOH includes all hours for which the Wind Turbines were unavailable.

EH includes, for example, Seller Excuse Hours.

Given these assumed facts, the Available Hours for the Wind Turbines during the Availability Period would be calculated as follows:

$$UH = FOH - EH$$

$$8,000 \text{ hours} = 12,000 \text{ hours} - 4,000 \text{ hours}$$

$$\text{Sum of Available Hours} = PH - UH$$

$$894,280 \text{ hours} = 902,280 \text{ hours} - 8,000 \text{ hours}$$

**Actual Facility Availability Percentage**

Given these assumed facts, the Actual Availability Percentage for the Facility during the Availability Period in question would be calculated as follows:

- (a) Available Hours: 894,280 hours
- (b) Sum of Period Hours: 902,280 hours
- (c) Actual Availability Percentage: (Sum of Available Hours/Sum of Period Hours) x 100  

$$= (894,280/902,280 \text{ hours}) \times 100 = 99.1\%$$

## II. Example of Availability Percentage Calculation (FAILED)

The sample calculation set forth below is based on the following assumed facts:

During the Availability Period in question, 103 Wind Turbines had been completed and were part of the Facility, bringing the Final Facility Installed Capacity to 230 MW.

The Wind Turbines had the following operating characteristics:

	Hours	Wind Turbines Affected	Wind Turbine Hours
Period Hours ("PH")	8,760	103	902,280
Unavailable Hours ("FOH")			110,000
Excused Hours ("EH")			6,000
Unexcused Hours ("UH")			104,000

FOH includes all hours for which the Wind Turbines were unavailable.

EH includes, for example, Seller Excuse Hours.

Given these assumed facts, the Available Hours for the Wind Turbines during the Availability Period would be calculated as follows:

$$UH = FOH - EH$$

$$104,000 \text{ hours} = 110,000 \text{ hours} - 6,000 \text{ hours}$$

$$\text{Sum of Available Hours} = PH - UH$$

$$798,280 \text{ hours} = 902,280 \text{ hours} - 104,000 \text{ hours}$$

### Actual Facility Availability Percentage

Given these assumed facts, the Actual Availability Percentage for the Facility during the Availability Period in question would be calculated as follows:

- (a) Available Hours: 798,280 hours
- (b) Sum of Period Hours: 902,280 hours
- (c) Actual Availability Percentage: (Sum of Available Hours/Sum of Period Hours) x 100

$$= (798,280 \text{ hours}/902,280 \text{ hours}) \times 100 = 88.5\%$$

### **Example of Availability Damages**

Example of Availability Damages based on the following assumed facts:

- (a) Seller's Guaranteed Mechanical Percentage= 90%.
- (b) Seller's Actual Availability Percentage= 88.5%.
- (c) Renewable Energy Payment Rate = \$18.10
- (d) Expected Facility Output = 1,029,563 MWhs.

Given these assumed facts, Seller calculates the Availability Damages due to Company as follows:

Renewable Energy Payment Rate x ((Guaranteed Mechanical Availability Percentage – Actual Availability Percentage) x Expected Facility Output) = Availability Damages.

$$\$18.10 \times ((90\% - 88.5\%) \times 1,029,563) = \$279,526.35$$

# WIND ENERGY PURCHASE AGREEMENT

BETWEEN

**SOUTHWESTERN PUBLIC SERVICE COMPANY, A NEW  
MEXICO CORPORATION**

AND

[REDACTED]



- [date] -

## TABLE OF CONTENTS

	<b>PAGE</b>
<b>Article 1 - Rules of Interpretation.....</b>	<b>1</b>
1.1 Interpretation.....	1
1.2 Interpretation with Other Agreements.....	2
1.3 Good Faith and Fair Dealing.....	2
<b>Article 2 – Term and Termination.....</b>	<b>2</b>
<b>Article 3 – Facility Description .....</b>	<b>3</b>
3.1 Description.....	3
3.2 General Design of the Facility.....	3
<b>Article 4 - Implementation .....</b>	<b>3</b>
4.1 Project Development.....	3
4.2 Environmental Matters .....	4
4.3 Permits.....	5
4.4 Governmental Inspections .....	6
4.5 Commercial Operation.....	6
4.6 Test Energy .....	7
<b>Article 5 - Delivery.....</b>	<b>8</b>
5.1 Arrangements .....	8
5.2 Market Changes .....	8
5.3 Electric Metering Devices .....	9
<b>Article 6 – Conditions Precedent.....</b>	<b>10</b>
6.1 PUC Approval.....	10
6.2 Other Company CPs.....	11
6.3 Seller CPs.....	11
<b>Article 7 – Sale and Purchase .....</b>	<b>11</b>
7.1 General Obligation.....	11
7.2 AGC.....	11
7.3 Green Benefits.....	11
7.4 Ancillary Services .....	12
<b>Article 8 – Payment Calculations.....</b>	<b>13</b>
8.1 Payment for Renewable Energy .....	13
8.2 Excess Energy.....	13
8.3 Curtailment .....	14
<b>Article 9 – Billing and Payment.....</b>	<b>16</b>
9.1 Billing .....	16
9.2 Payment.....	17
9.3 Billing Disputes.....	17

<b>Article 10 – Operations and Maintenance .....</b>	<b>17</b>
10.1 Operation and Administration .....	17
10.2 Facility Maintenance .....	18
10.3 Books and Records .....	18
10.4 Access to Facility .....	19
10.5 Real Time Data.....	19
10.6 Accreditation .....	19
10.7 Operating Committee and Operating Procedures.....	19
<b>Article 11 – Security for Performance .....</b>	<b>20</b>
11.1 Security Fund.....	20
11.2 Replenishment.....	21
11.3 Form .....	21
11.4 Replacement.....	22
11.5 Survival .....	23
11.6 Expenses.....	23
<b>Article 12 – Default and Remedies.....</b>	<b>23</b>
12.1 Default by Seller: General.....	23
12.2 Default by Seller: Failure to Achieve COD .....	27
12.3 Default by Company .....	27
12.4 Limitations on Damages .....	29
12.5 Step-In Rights .....	30
12.6 Bankruptcy.....	31
12.7 Cumulative Remedies.....	32
12.8 Duty to Mitigate.....	32
<b>Article 13 – Dispute Resolution .....</b>	<b>32</b>
13.1 Negotiation.....	32
13.2 Time Bar .....	32
13.3 No Termination Pending Dispute Resolution .....	32
13.4 Governing Law.....	33
13.5 Venue .....	33
13.6 Waiver of Jury Trial.....	34
<b>Article 14 – Force Majeure.....</b>	<b>34</b>
14.1 Definition.....	34
14.2 Applicability of Force Majeure.....	34
14.3 Limitations on Effect of Force Majeure .....	35
<b>Article 15 – Representations and Warranties .....</b>	<b>35</b>
<b>Article 16 - Insurance .....</b>	<b>36</b>
16.1 Evidence of Insurance .....	36
16.2 Policy Requirements.....	37
16.3 No Implied Limitation .....	37
16.4 Term and Modification of Insurance.....	37



16.5	Application of Proceeds .....	37
<b>Article 17 - Indemnity .....</b>		<b>38</b>
17.1	Indemnification: General .....	38
17.2	Indemnification: Environmental.....	38
17.3	Limitations.....	38
17.4	Procedures .....	38
17.5	Amounts Owed .....	39
<b>Article 18 – Lender Provisions .....</b>		<b>39</b>
18.1	Accommodation of Facility Lender.....	39
18.2	Notices.....	40
<b>Article 19 - Assignment .....</b>		<b>40</b>
19.1	Assignment by Seller .....	40
19.2	Assignment by Company .....	41
19.3	ROFO .....	42
19.4	PFT .....	43
19.5	Option .....	44
19.6	Memo of Option .....	46
<b>Article 20 - Miscellaneous .....</b>		<b>46</b>
20.1	Notices.....	46
20.2	Taxes.....	46
20.3	Applicable Laws.....	47
20.4	Fines and Penalties .....	47
20.5	Rate Changes.....	48
20.6	Certifications .....	48
20.7	Disclaimer of Third Party Beneficiaries .....	48
20.8	Relationship of the Parties.....	48
20.9	Survival of Obligations .....	48
20.10	Severability .....	49
20.11	Complete Agreement; Amendments.....	49
20.12	Waiver.....	49
20.13	Binding Effect.....	49
20.14	Headings.....	49
20.15	Counterparts .....	49
20.16	Press Release .....	49
20.17	Exhibits .....	49
20.18	Confidentiality .....	49

EXHIBIT A	DEFINITIONS
EXHIBIT B	CONSTRUCTION MILESTONES
EXHIBIT C	FACILITY DESCRIPTION AND SITE MAPS
EXHIBIT D	NOTICES AND CONTACT INFORMATION

EXHIBIT E INSURANCE COVERAGE  
EXHIBIT F SELLER'S NEEDED PERMITS  
EXHIBIT G FORM OF LETTER OF CREDIT  
EXHIBIT H FORM OF GUARANTY  
EXHIBIT I AGC PROTOCOLS; DATA COLLECTION; TECHNICAL SPECS  
EXHIBIT J ENERGY PAYMENT RATE; COMMITTED ENERGY  
EXHIBIT K LENDER CONSENT PROVISIONS  
EXHIBIT L PSA PROVISIONS  
EXHIBIT M AVAILABILITY GUARANTY CALCULATION

**WIND ENERGY PURCHASE AGREEMENT**  
**BETWEEN**  
**SOUTHWESTERN PUBLIC SERVICE COMPANY**  
**AND**  
**[REDACTED], LLC**

This Wind Energy Purchase Agreement (this “PPA”) is made as of this [REDACTED] day of [REDACTED], 20[REDACTED], by and between (i) Southwestern Public Service Company, a New Mexico corporation with a principal place of business at 1800 Larimer Street, Denver, CO 80202 (“Company”), and (ii) [REDACTED], LLC, a [REDACTED] [limited liability company] with a principal place of business at [REDACTED] (“Seller”). Company and Seller are hereinafter referred to individually as a “Party” and collectively as the “Parties.”

WHEREAS Seller desires to develop, design, construct, interconnect, own, operate and maintain the Facility as defined herein; and

WHEREAS Seller desires to sell and deliver, and Company desires to accept and receive, certain products and services generated and delivered from the Facility to the Point of Delivery at the prices and on the terms and conditions set forth in this PPA.

NOW THEREFORE, in consideration of the mutual covenants herein contained, the sufficiency and adequacy of which are hereby acknowledged, the Parties agree to the following:

**Article 1 - Rules of Interpretation**

1.1 Interpretation.

(A) Capitalized terms listed in this PPA shall have the meanings set forth in Exhibit A - Definitions or as otherwise defined in this PPA, whether in the singular or the plural or in the present or past tense. Words not otherwise defined in this PPA shall (i) have meanings as commonly used in the English language, (ii) be given their generally accepted meaning consistent with Good Utility Practice, and (iii) be given their well known and generally accepted technical or trade meanings.

(B) The following rules of interpretation shall apply: (1) The masculine shall include the feminine and neuter; (2) references to “Articles,” “Sections” or “Exhibits” shall be to articles, sections, or exhibits of this PPA except as the context may otherwise require; (3) all Exhibits are incorporated into this PPA (*provided, however*, that in the event of a conflict with the terms of this PPA, the PPA shall control); and (4) use of the words “include” or “including” or similar words shall be interpreted as “include without limitation” or “including, without limitation.”

(C) This PPA was negotiated and prepared by both Parties with the advice and participation of counsel. None of the provisions hereof shall be construed against one Party on the ground that such Party is the author of this PPA or any part hereof.

## 1.2 Interpretation with Other Agreements.

(A) This PPA does not provide Seller authorization to interconnect the Facility or inject power into the Transmission Authority's System. Seller shall contract for interconnection services in accordance with the applicable Transmission Tariff. Seller acknowledges that the Interconnection Agreement is/will be a separate contract and that (i) this PPA is not binding on the Transmission Authority, (ii) this PPA does not create any rights between Seller and the Transmission Authority, and (iii) the Interconnection Agreement does not modify the Parties' rights and obligations under this PPA. The applicable Transmission Authority shall be deemed to be a separate and unaffiliated contracting party for purposes of this PPA, regardless whether such Transmission Authority is Company or an Affiliate of Company.

(B) This PPA does not provide for the supply of retail power for purposes of operating the Facility, including start-up, shut-down, oil heating, turbine adjustment, HVAC or any other purpose ("House Power"). Seller shall contract with the utility providing House Power to the Site (the "Local Provider") for the supply of House Power. Seller acknowledges that (i) Seller must obtain House Power independently, (ii) this PPA is not binding on the Local Provider, (iii) this PPA does not create any rights between Seller and the Local Provider, and (iv) Seller's contract for House Power does not affect the Parties' rights and obligations under this PPA. For purposes of this PPA, the Local Provider shall be deemed to be a separate and unaffiliated contracting party regardless whether the Local Provider is Company or an Affiliate of Company; *provided* that, if (and only if) the Local Provider is Company or an Affiliate of Company, Seller may obtain House Power by self-generating and netting such self-generation from the Contract Energy provided to Company unless prohibited by Applicable Law .

1.3 Good Faith and Fair Dealing. The Parties shall act reasonably and in accordance with the principles of good faith and fair dealing in the performance of this PPA. Unless expressly provided otherwise in this PPA, (a) when this PPA specifically references the consent, approval, or similar action by a Party, such consent or approval shall not be unreasonably withheld, conditioned or delayed, and (b) wherever this PPA specifically gives a Party a right to determine, require, specify or take similar action with respect to a matter, such determination, requirement, specification or similar action shall be Commercially Reasonable.

## **Article 2 - Term and Termination**

This PPA shall become effective as of the date of its execution, and shall remain in full force and effect until the 11:59 pm on the last Day of the calendar month during which occurs the [ ]<sup>th</sup> anniversary of the Commercial Operation Date (the "Scheduled Termination Date"), subject to early termination as provided in this PPA. Applicable provisions of this PPA shall continue in effect after termination to the extent necessary to (i) provide for final billings, payments and adjustments, (ii) enforce or complete the duties, obligations or responsibilities of the Parties (including under Section 12.1(B)-(D) [(E)], Section 12.2(C), Section 12.3(B)-(C), Article 13 and Article 17 below), and (iii) address any remedies or indemnifications arising prior to termination.

### Article 3 - Facility Description

3.1 Description. Seller shall construct, interconnect, own, operate, and maintain the Facility, as further described in Exhibit C - Facility Description. A scaled map that identifies the Site, the location of the Facility, the Interconnection Point and Interconnection Facilities, the Point of Delivery, and other important facilities, is included in Exhibit C - Facility Description.

#### 3.2 General Design of the Facility.

(A) Seller shall design, construct, operate and maintain the Facility according to Good Utility Practices and the Interconnection Agreement.

(B) The Facility shall include all equipment specified in Exhibit C - Facility Description and otherwise necessary to fulfill Seller's obligations under this PPA, including all equipment necessary (i) to meet the requirements of Exhibit I - Operating Standards, and (ii) to interconnect successfully with the Transmission Authority's System for the delivery of Renewable Energy to the Point of Delivery.

(C) The Nameplate Capacity of the Facility shall be [ ] MW, +/- 0.5%. Seller shall certify to Company the final actual Nameplate Capacity of the Facility promptly following COD.

### Article 4 - Implementation

#### 4.1 Project Development.

(A) Seller shall enter into and perform at its expense all contracts required for (i) the engineering, procurement, construction, acquisition, manufacture, delivery and installation of the Facility, and (ii) the generation and delivery of Renewable Energy from the Facility to the Point of Delivery (generally, the "Construction Contracts") with qualified and experienced contractors. Upon written request by Company, Seller shall provide copies of any or all Construction Contracts to Company. All Construction Contracts obtained by Company shall be deemed Confidential Information subject to Section 20.18 below.

(B) In its efforts to achieve COD, Seller shall use Commercially Reasonable Efforts to achieve the milestones set forth in Exhibit B – Construction Milestones, and shall notify Company promptly following achievement of each such milestone.

(C) Prior to the Commercial Operation Date, Seller shall (i) submit monthly progress reports to Company in a form agreed by the Parties, advising Company of the current status of each Construction Milestone, any significant developments or delays (along with an action plan for making up delays), and Seller's best estimate of the Commercial Operation Date; (ii) provide copies of reports submitted to the Facility Lender relating to status, progress and development of the project, and (iii) invite Company to participate in monthly meetings to discuss the progress reports,

answer questions, and assess the schedule. Seller shall make all relevant counterparties under the Construction Contracts available to Company, upon request, in order to keep Company fully informed on the status of development.

(D) Upon request, Company shall have the right to monitor the construction, start-up, testing, and operation of the Facility at the Site to verify compliance with this PPA, *provided, however*, that Company shall comply with all of Seller's applicable safety and health rules and requirements.

(E) Neither Company's review of Construction Contracts and Seller's reports, nor its discussions with Seller and its contractors, nor its monitoring of development and construction the Facility, shall be construed as endorsement by Company of the design, engineering, construction or testing thereof nor as any express or implied warranty as to the performance, safety, durability, or reliability of the Facility.

#### 4.2 Environmental Matters.

(A) No later than 60 Days following State Regulatory Approval, Seller shall complete and provide to Company a comprehensive independent "Phase I" environmental investigation of the Site or its equivalent (including associated raw data, if requested by Company). Seller shall notify Company promptly (i) if (and to what extent) any Environmental Contamination on the Site will preclude or interfere with Seller's ability to perform its obligations under this PPA, and (ii) Seller's plan for remediation thereof that would allow Seller to perform this PPA as and when due. The Phase I report delivered to Company under this paragraph shall be deemed Confidential Information for purposes of Section 20.18.

(B) Throughout the Term, Seller promptly shall

1. disclose to Company and remediate any Environmental Contamination identified at the Site;

2. provide to Company copies of any further environmental assessments or investigations of the Site (including associated raw data, if requested by Company); and

3. disclose to Company the existence of any enforcement, legal, or regulatory action or proceeding relating to any alleged presence of Environmental Contamination and/or the alleged violation of any Applicable Law related to the protection of endangered, migratory or other protected species.

(C) For purposes hereof:

1. "Environmental Contamination" means the introduction or presence of Hazardous Materials at such levels, quantities or location, or of such form or character, that (i) requires remediation under Applicable Law, (ii) present a material risk that the Site will not be available or usable for the purposes

contemplated by this PPA, and/or (iii) will preclude or interfere with Seller's ability to perform its obligations under this PPA as and when due.

2. "Hazardous Materials" means any substance, material, gas, or particulate matter that is regulated by any Governmental Authority as an environmental pollutant or dangerous to public health, public welfare, or the natural environment (including protection of non-human forms of life, land, water, groundwater, and air), including any material or substance that is (i) defined as "toxic," "polluting," "hazardous waste," "hazardous material," "hazardous substance," "extremely hazardous waste," "solid waste" or "restricted hazardous waste" under any provision of local, state, or federal law; (ii) petroleum, including any fraction, derivative or additive; (iii) asbestos; (iv) polychlorinated biphenyls; (v) radioactive material; (vi) designated as a "hazardous substance" pursuant to the Clean Water Act, 33 U.S.C. §1251 *et seq.* (33 U.S.C. §1251); (vii) defined as a "hazardous waste" pursuant to the Resource Conservation and Recovery Act, 42 U.S.C. §6901 *et seq.* (42 U.S.C. §6901); (viii) defined as a "hazardous substance" pursuant to the Comprehensive Environmental Response, Compensation, and Liability Act, 42 U.S.C. §9601 *et seq.* (42 U.S.C. §9601); (ix) defined as a "chemical substance" under the Toxic Substances Control Act, 15 U.S.C. §2601 *et seq.* (15 U.S.C. §2601); or (x) defined as a pesticide under the Federal Insecticide, Fungicide, and Rodenticide Act, 7 U.S.C. §136 *et seq.* (7 U.S.C. §136).

#### 4.3 Permits.

(A) Seller shall obtain and pay for all Permits necessary or advisable under Good Utility Practice for the construction, ownership, operation and maintenance of the Facility and the generation and delivery of the output from the Facility to Company. Seller shall keep Company informed as to the status of its permitting efforts and shall provide Company the opportunity to review and comment on major applications for draft and final Permits. Seller shall promptly inform Company of (i) any Permits which Seller is unable to obtain, that are delayed, limited, suspended, terminated or otherwise constrained, along with a statement of whether and to what extent this circumstance may limit or preclude Seller's ability to perform under this PPA, and (ii) Seller's plan to overcome such issue(s) to allow Seller to perform this PPA as and when due. Company shall have the right to inspect and obtain copies of all Permits held by Seller.

(B) Seller represents and warrants to Company that, except for those Permits identified in Exhibit F - Seller's Needed Permits (each of which Seller anticipates will be obtained by Seller in the ordinary course of business), all Permits and other actions required or recommended by applicable Governmental Authorities to authorize Seller's execution, delivery and performance of this PPA (including "takings" permits with respect to protected species) have been duly obtained and are in full force and effect.

(C) Throughout the Term, Seller promptly shall disclose to Company the existence of any enforcement, legal, or regulatory action or proceeding relating to the

alleged violation of any Permit held by Seller, which proceeding (if successful) could materially interfere with Seller's performance of this PPA.

(D) For purposes hereof, "Permits" means all applicable construction, land use, air quality, emissions control, environmental, protected species, and other permits, licenses and approvals from any Governmental Authority for construction, ownership, operation and maintenance of the Facility and the generation and delivery of Renewable Energy therefrom.

4.4 Governmental Inspections. Seller shall notify Company (i) sufficiently in advance of any known upcoming significant inspections by any Governmental Authority relating to the Facility, to allow Company the opportunity to attend, and (ii) promptly after any unscheduled or impromptu inspection with a description of the nature and outcome of such inspection.

4.5 Commercial Operation.

(A) Seller shall cause COD to occur no later than [REDACTED], 20[REDACTED] (the "Target COD"). Company shall not be obligated to accept and establish a Commercial Operation Date earlier than [REDACTED], 20[REDACTED] (*insert date that is 90 days prior to Target COD*).

(B) Seller shall notify Company of the date on which Seller believes the Facility has achieved Commercial Operation (a "COD Notice"). A COD Notice shall include all necessary supporting documentation of the satisfaction or occurrence of all COD Conditions. Company shall have 10 Business Days to review a COD Notice and raise any Commercially Reasonable objection to Seller's satisfaction of any of the COD Conditions, *provided, however*, that Seller's COD Notice shall be deemed accepted by Company if Company fails to object within such time period. Seller may notify Company of completion of one or more COD Conditions on an individual and incremental basis prior to COD, *provided, however*, that Company shall in all cases have up to 10 Business Days to review and object to each such notice.

(C) For purposes hereof:

1. the "Commercial Operation Date" or "COD" means 12:01 am on the Day following the date on which Company receives Seller's COD Notice, without valid objection thereto by Company; and

2. the "COD Conditions" are:

(a) an officer of Seller, authorized to bind Seller and who is familiar with the Facility, has provided written confirmation that (1) all necessary and material Permits have been obtained and are in full force and effect, (2) Seller is in compliance with this PPA in all material respects, (3) Seller has made all necessary arrangements to obtain and pay the Local Provider for House Power, and (4) the Facility is available to commence normal operations in accordance with Seller's operating agreements, Construction Contracts, and applicable manufacturers' warranties;



(b) Seller has proven to Company's reasonable satisfaction that (1) Seller and the Transmission Authority have signed the Interconnection Agreement, and Seller has received no notice of breach thereof from the Transmission Authority, (2) the Facility is interconnected to the Transmission Authority's System, has been fully tested, has achieved initial synchronization, and has been successfully operated at a generation level acceptable to the Transmission Authority, without experiencing any abnormal or unsafe operating conditions on any interconnected system, and (3) Seller has made all other arrangements necessary to deliver Renewable Energy from the Facility to the Point of Delivery during the Term;

(c) Seller has obtained and provided to Company an independent registered professional engineer's certification stating that the Facility has been completed in all material respects, except for "punch list" items that do not have a Material Adverse Effect on the ability of the Facility to operate for its intended purpose;

(d) Seller has demonstrated the reliability of the Facility's communications systems and AGC interface with Company's EMCC, and the capability of the Facility to receive and respond to signals from Company's SCADA System; and

(e) Wind Turbines comprising at least 95% of the Nameplate Capacity planned for the Facility, and associated equipment sufficient to allow such Wind Turbines to generate and deliver Renewable Energy to the Point of Delivery, have been installed and become operable.

(D) For purposes hereof, the first "Commercial Operation Year" shall mean the period starting at 12:01 a.m. on the Commercial Operation Date and ending at 11:59 pm on the last Day of the calendar month in which the first anniversary of COD occurs, and each successive "Commercial Operation Year" shall mean the 12 month period following the prior Commercial Operation Year.

#### 4.6 Test Energy.

(A) Seller shall provide Company and Transmission Authority with the information necessary to have the Facility registered with the Transmission Authority for inclusion in any generation modeling maintained by the Transmission Authority, sufficiently in advance to allow the Facility to be registered in such model at least four months prior to generating any Test Energy. Company shall cooperate reasonably to assist in the registration of the Facility to allow generation of Test Energy.

(B) Seller shall coordinate the production and delivery of Test Energy with Company, with not less than seven Business Days' prior Notice, or such other Commercially Reasonable prior Notice as Company may reasonably request.

(C) For purposes hereof, "Test Energy" means Renewable Energy generated by the Facility prior to COD, required to satisfy the COD Conditions.

## Article 5 - Delivery

### 5.1 Arrangements.

(A) Seller shall be responsible for arranging, maintaining and paying the costs associated with the interconnection of the Facility to the Transmission Authority's System. Seller shall comply with the Transmission Authority's requirements for interconnection and shall comply with all requirements set forth in the applicable Transmission Tariff. Seller's interconnection application shall request that the Transmission Authority study the Facility for both Energy Resource Interconnection Service and Network Resource Interconnection Service under the Transmission Tariff. The resulting Interconnection Agreement must include Energy Resource Interconnection Service at a minimum. Seller shall cooperate reasonably in any request by Company to assist in Company's efforts to have the Facility approved as a Network Resource or equivalent classification pursuant to the applicable Transmission Tariff.

(B) Seller hereby authorizes Company to contact, discuss and obtain information concerning the Facility and Interconnection Facilities directly with/from the Transmission Authority. Promptly upon request by Company, Seller shall confirm such authorization in writing to the Transmission Authority and any applicable transmission owners in such form as may be requested by Company or the Transmission Authority.

(C) To the extent required, Company shall arrange and be responsible for scheduling and transmission services at and beyond the Point of Delivery. To the extent applicable, Company shall be the market participant for the Facility, as defined by the Transmission Authority.

(D) Seller shall be responsible for all interconnection, electric losses, transmission and ancillary service arrangements and costs required to deliver, on a firm transmission service basis, Renewable Energy from the Facility to the Point of Delivery. Company shall be responsible for all electric losses, transmission and ancillary service arrangements and costs required to transmit and deliver Renewable Energy beyond the Point of Delivery.

### 5.2 Market Changes.

(A) If at any time during the Term, the Transmission Authority changes or the facilities at the Point of Delivery cease to be subject to the Transmission Tariff, the Parties shall cooperate in good faith to facilitate the delivery of Renewable Energy from the Point of Delivery to Company's load, at the least possible cost to the Parties, consistent with this PPA to the extent possible.

(B) If and to the extent that changes to the rules of the Market Operator require Company to change the manner in which Company schedules and dispatches the Facility, the Parties shall cooperate in good faith to change their protocols for operation of the Facility accordingly, at the least possible cost to the Parties, consistent with this PPA to the extent possible.

(C) In the event that improvements to the Facility or other expenditures by Seller are necessary to comply with this Section 5.2, which expenditures must be capitalized by Seller under generally accepted accounting principles consistently applied, Company shall reimburse Seller one percent (1%) of such expenditures per month, beginning with the first month following substantial completion of such expenditures and ending upon the earlier to occur of (i) the 100<sup>th</sup> month following the start of such reimbursements, and (ii) the end of the Term of this PPA.

### 5.3 Electric Metering Devices.

(A) All Electric Metering Devices used to measure energy shall be owned, installed, and maintained in accordance with the Interconnection Agreement, at no cost to Company.

1. Meter readings will be adjusted to reflect losses from the Electric Metering Devices to the Point of Delivery in accordance with applicable manufacturers' parameters or as otherwise agreed by the Parties.

2. Seller shall arrange any necessary authorization to provide Company access to all Electric Metering Devices for purposes ancillary to this PPA, and shall provide Company the opportunity to be present at any time when such Electric Metering Devices are to be inspected, tested or adjusted.

(B) Either Party may elect to install and maintain, at its own expense, backup metering devices ("Back-Up Metering"), *provided, however*, that the specifications, installation and testing of any such Back-Up Metering shall be consistent with the requirements for the Electric Metering Devices. Upon written request from the other Party, the installing Party shall test the Back-Up Metering. The actual cost of any such test shall be borne by the Party requesting the test, unless, upon such test, Back-Up Metering is inaccurate by more than one percent, in which case the cost of the retest shall be borne by the installing Party. If requested in writing, the installing Party shall provide copies of any inspection or testing reports to the requesting Party.

(C) If an Electric Metering Device or Back-Up Metering fails to register, or if the measurement is inaccurate by more than one percent, an adjustment shall be made correcting all measurements as follows:

1. If the Electric Metering Device is found to be defective or inaccurate, the Parties shall use Back-up Metering, if installed, to determine the amount of such inaccuracy, *provided, however*, that Back-Up Metering has been tested and maintained and adjusted for losses on the same basis as the Electric Metering Device. If Back-Up Metering is not installed, or Back-Up Metering is also found to be inaccurate by more than one percent, the Parties shall use the best available information for the period of inaccuracy, adjusted for losses to the Point of Delivery in accordance with applicable manufacturers' parameters or as otherwise agreed by the Parties.

2. If the Parties cannot agree on the actual period during which inaccurate measurements were made, the period shall be the shorter of (i) the last one-half of the period from the last previous test of the Electric Metering Device to the test that found the Electric Metering Device to be defective or inaccurate, or (ii) 180 Days immediately preceding the test that found the Electric Metering Device to be defective or inaccurate.

3. To the extent that an adjustment period covers a period of deliveries for which payment has already been made by Company, Company shall use the corrected measurements as determined in accordance with this Article 5 to re-compute the amount due for the period of the inaccuracy and shall subtract the previous payments made by Company for this period from such re-computed amount. The net difference shall be reflected as an adjustment on the next regular invoice in accordance with Article 9.

## **Article 6 - Conditions Precedent**

### **6.1 State Regulatory Approval.**

(A) No later than 45 Days after the date of this PPA, Company may apply to the State Regulatory Agency for for State Regulatory Approval. If Company fails to apply for State Regulatory Approval within 45 Days following the date of this PPA, Company shall be deemed to have waived its right to obtain State Regulatory Approval and to terminate this PPA under this Section 6.1, and this PPA shall remain in full force and effect thereafter.

(B) If Company applies for State Regulatory Approval, Company shall use Commercially Reasonable Efforts to obtain State Regulatory Approval as soon as reasonably practicable. Seller shall cooperate with Company's efforts to obtain State Regulatory Approval, including provision of site-specific surveys for endangered species, avian migration pathways and critical habitats.

(C) If Company applies for State Regulatory Approval, Company shall have the right to terminate this PPA, without any further financial or other obligation to Seller as a result of such termination, by notice to Seller

1. at any time within 30 Days following issuance of a written order by the State Regulatory Agency rejecting State Regulatory Approval, or granting State Regulatory Approval with conditions unacceptable to Company in its sole discretion;

2. at any time between the 180<sup>th</sup> and 215<sup>th</sup> Day following Company's application for State Regulatory Approval, if prior to the date of such termination the State Regulatory Agency has not issued a written order granting or rejecting State Regulatory Approval;

3. at any time within 30 Days following timely request for reconsideration (in whole or in any material part) by any third party with standing, of a written State Regulatory Agency order granting State Regulatory Approval; and/or

4. at any time within 30 Days following timely appeal by any party with standing, of a written State Regulatory Agency order granting State Regulatory Approval.

If Company is eligible but fails to terminate this PPA by the applicable date, Company shall be deemed to have waived its right to terminate this PPA under this Section 6.1(C), and this PPA shall remain in full force and effect thereafter.

6.2 Other Company CPs. *[if any].*

6.3 Seller CPs. *[if any - bid specific].*

## **Article 7 - Sale and Purchase**

7.1 General Obligation.

(A) Beginning on the Commercial Operation Date, Seller shall generate from the Facility, deliver to the Point of Delivery, and sell to Company, and Company shall receive and purchase at the Point of Delivery, the Renewable Energy and other products and services required by this PPA. Seller shall not curtail or interrupt deliveries of Renewable Energy to Company for economic reasons of any type.

(B) Title and risk of loss of the products and services transacted by this PPA shall transfer from Seller to Company at the Point of Delivery.

7.2 AGC. Beginning on the Commercial Operation Date, Company shall dispatch the Facility through the EMCC AGC system. Seller shall ensure that, throughout the Term:

(A) the SCADA signal is capable of functioning on all AGC Set Points within the margin of error specified in the manufacturer's energy set point margin of error; and

(B) the Facility AGC Remote/Local status is in "Remote" set-point control during normal operations.

7.3 Green Benefits. The Parties acknowledge that existing and future Applicable Laws create significant value in the ownership, use and allocation of Green Benefits. To the full extent allowed by Applicable Law, Seller hereby assigns to Company (and Company shall own and be entitled to claim) all Green Benefits to the extent existing or created during the Term associated with the Facility and the Renewable Energy purchased by Company hereunder, at no additional charge to Company under this PPA.

(A) Seller hereby irrevocably assigns to Company all rights, title and authority for Company to register the Facility as an Eligible Energy Resource and own, hold and manage the Green Benefits associated with the Facility in Company's own name and to Company's account, including any rights associated with any renewable energy information or tracking system that exists or may be established (including participation in any applicable REC Registration Program) with regard to monitoring, registering, tracking, certifying, and/or trading such Green Benefits. Seller hereby authorizes Company to act as its agent for the purposes of registering the Facility as an Eligible Energy Resource, and tracking, certifying, registering and reporting such Green Benefits. Seller grants to Company full authority to hold, use, sell and/or trade such Green Benefits for its own account in all applicable renewable energy information or tracking systems. Upon the request of Company, at no cost to Company, (i) Seller shall deliver or cause to be delivered to Company appropriate attestations/certifications of Green Benefits, and (ii) Seller shall cooperate with Company's tracking, registration, reporting and certification of Green Benefits.

(B) Prior to the Commercial Operation Date, Seller shall make all applications and/or filings required by Applicable Law for accreditation of Green Benefits and for the assignment of such Green Benefits to Company.

(C) For purposes hereof, "Green Benefits" means existing and future environmental credits, benefits or attributes, emissions reductions and avoidances (including emission rate credits), offsets, allowances and green tags, attributable to the Facility during the Term and/or Renewable Energy sold to Company under this PPA, recognized by Applicable Law, including any rights to compensation therefor. Green Benefits include

1. Renewable Energy Credits;
2. Avoided emissions of pollutants to the air, soils or waters, such as sulfur oxides (SO<sub>x</sub>), nitrogen oxides (NO<sub>x</sub>) and carbon monoxide (CO);
3. Avoided emissions of greenhouse gases (such as carbon dioxide (CO<sub>2</sub>), methane (CH<sub>4</sub>), nitrous oxide (N<sub>2</sub>O), hydrofluorocarbons (HFCs), perfluorocarbons (PFCs) and sulfur hexafluoride (SF<sub>6</sub>)) that have been or may in the future be determined by the United Nations Intergovernmental Panel on Climate Change or by Applicable Law to contribute to the threat of climate change; and
4. Reporting rights for avoided emissions, such as Green Tag Reporting Rights.

#### 7.4 Ancillary Services.

(A) Company shall be entitled and Seller shall make available to Company all Ancillary Services associated with the Facility, at no additional charge to Company. Seller shall use Commercially Reasonable Efforts to maximize the Ancillary Services available from the Facility.

(B) Any compensation Seller receives under the Interconnection Agreement or otherwise from third parties for Ancillary Services shall be provided to Company at no additional cost to Company under this PPA. To implement the foregoing, Seller shall credit Company, as a reduction to Seller's monthly invoice or other mutually-agreed mechanism, for any compensation that Seller receives from third parties for Ancillary Services; *provided*, that if a Governmental Authority or Transmission Authority implements new or revised requirements for generators to create, modify, or supply Ancillary Services, requiring Seller to install additional equipment after the date hereof to meet such requirements, then Seller shall be allowed to reduce the amount to be credited to Company for Ancillary Services by an amount sufficient to recover the cost of such additional equipment. Any cost not so recovered by Seller in any billing period shall be carried forward as a reduction of the amount of the credit in subsequent billing periods.

(C) For purposes hereof, "Ancillary Services" means ancillary services addressed under the Transmission Tariff from time to time (if any), which are associated, directly or indirectly, with the capacity of the Facility or the generation and/or transmission of Renewable Energy from the Facility from time to time, including any rights to compensation therefor. By way of example only, "Ancillary Services" may include capacity or reliability attributes, resource adequacy characteristics, locational benefit attributes, and/or VaR generation.

## **Article 8 - Payment Calculations**

### **8.1 Payment for Renewable Energy.**

(A) Company shall pay Seller a payment rate equal to 70% of the Energy Payment Rate for the first Commercial Operation Year, for all Test Energy delivered to Company.

(B) Commencing on the Commercial Operation Date, Company shall pay the Energy Payment Rate to Seller for all Renewable Energy, up to 115% of the Committed Energy in each Commercial Operation Year, *provided* that Company shall never be required to pay for net instantaneous output of the Facility (as measured at the Point of Delivery) in excess of the Nameplate Capacity.

(C) The Energy Payment Rate shall be deemed Confidential Information for purposes of Section 20.18 below.

### **8.2 Excess Energy.**

(A) Seller shall notify Company promptly upon Seller's delivery of Renewable Energy hereunder that exceeds 110% of the Committed Energy for a Commercial Operation Year. Within 10 Business Days of any such notice, Company shall elect by notice to Seller either to accept or to decline any Excess Energy generated by the Facility through the balance of such Commercial Operation Year.

Failure by Company to deliver such notice shall be deemed an election by Company to decline any Excess Energy for that Commercial Operation Year.

(B) If Company elects to accept Excess Energy, Company shall pay Seller the full Energy Payment Rate for all Excess Energy for the balance of that Commercial Operation Year.

(C) If Company declines Excess Energy, (1) Company's purchases of Renewable Energy with respect to the applicable Commercial Operation Year shall cease when Renewable Energy generated by the Facility and delivered to the Point of Delivery reaches 115% of the Committed Energy for such Commercial Operation Year, and (2) Seller shall have the right to sell such Excess Energy (including associated RECs) to one or more third parties until the end of the applicable Commercial Operation Year, after which the Parties' obligations shall resume pursuant to this PPA. Seller shall be solely responsible for all costs and logistics associated with such third-party sales, including arranging transmission service and delivery at no cost to Company.

(D) For purposes hereof, "Excess Energy" means all energy generated by the Facility in any Commercial Operation Year (including any Compensable Curtailment Energy) in excess of 115% of the Committed Energy for such Commercial Operation Year.

### 8.3 Curtailment.

(A) Company may require Seller, by telephonic communication or through use of the AGC Set Point, to curtail the delivery of Renewable Energy to Company from the Facility, for any reason and in Company's sole discretion. Seller shall promptly comply with each such notification.

(B) For purposes hereof:

1. "Compensable Curtailment" means a curtailment of generation or delivery of Renewable Energy following COD arising out of the following (and only the following):

- i. a curtailment of the Facility by Company under Section 8.3(A) ;
- ii. disconnection of the Facility from the Transmission Authority's System pursuant to the Interconnection Agreement (due to an Emergency, event of Force Majeure or other problem beyond the Point of Delivery), provided that the disconnection is not caused by actions of Seller or problems with the Facility;
- iii. Company's scheduling and other market participation activities, including any energy offer made by Company with respect to the Facility; and



- iv. an election by Company to utilize non-firm transmission service to transmit Renewable Energy from the Point of Delivery to its load, and such non-firm transmission service is restricted or reduced by the applicable transmission service provider, except as provided in paragraph 2(iii) below.

2. “Non-Compensable Curtailment” means any curtailment of the output of the Facility other than a Compensable Curtailment. By way of example only, Non-Compensable Curtailments include curtailments of generation or delivery of Renewable Energy arising out of:

- (i) the restriction or reduction of firm transmission service by the applicable transmission service provider;
- (ii) the restriction or reduction of non-firm transmission service by the applicable transmission service provider to the extent such restriction or reduction would also have been imposed even if firm transmission service had been in place;
- (iii) maintenance outages, whether planned or unplanned, of any part of the transmission system or any testing of the transmission system;
- (iv) the lack of available transmission from the Facility to the Point of Delivery;
- (v) Seller’s failure to maintain in full force and effect any Permit to own, operate and/or maintain the Facility;
- (vi) a civil, regulatory or criminal proceeding for the protection of endangered, migratory or other protected species;
- (vii) Seller’s failure to abide by the AGC Protocols, or a failure of the Facility to respond to AGC instructions from the EMCC; and
- (viii) [REDACTED] MWh per Commercial Operation Year of otherwise Compensable Curtailment Energy that may be applied at the election of Company without compensation to Seller.] *bid-specific -- may be n/a*

3. “Compensable Curtailment Energy” for any period of Compensable Curtailment means the MWh represented by the Potential Energy less the Renewable Energy actually generated (if any), during such period. For purposes of determining Compensable Curtailment Energy, the amount of Potential Energy at any given time shall be calculated using the best-available data and methods to determine an accurate representation of the amount of curtailed Renewable Energy:

a. To the extent available, the Parties shall use Seller's real time Park Potential communicated to Company through the SCADA System as the proxy for Potential Energy, except to the extent that Park Potential is demonstrated not to accurately reflect the Potential Energy (plus or minus 2% average error for non-curtailement periods where generation exceeds 50% of nameplate capacity during one month).

b. During those periods of time when the Park Potential is unavailable or does not accurately represent Potential Energy, the Parties shall use the best available data obtained through Commercially Reasonable methods to determine the Potential Energy.

4. "Tax Benefits" means an amount equal to (a) the PTCs to which Seller would have been entitled with respect to Renewable Energy that could have been delivered but for a Compensated Curtailment pursuant to Section 8.2 of this PPA, plus (b) a "gross up" amount to take into account the federal, state and local income tax to Seller on such payments in lieu of PTCs so that the net amount retained by Seller, after payment of federal, state and local income taxes, is equal to the amount set forth in clause (A) of this definition.

(C) No payment shall be due to Seller from Company for Renewable Energy curtailed as a consequence of any Non-Compensable Curtailment, or for Compensable Curtailment Energy prior to COD.

(D) For all Compensable Curtailments following COD, Company shall pay to Seller (i) all amounts that Seller would have received from Company under this PPA had the resulting Compensable Curtailment Energy actually been delivered, plus (ii) the amount of any associated Tax Benefits to which Seller would have been entitled but did not receive as a result, on a grossed-up basis, assuming that Seller has elected to receive PTCs. For the avoidance of doubt, Seller shall not be entitled to recover any Tax Benefits to the extent Seller would not have been entitled to receive PTCs had the Compensable Curtailment Energy actually been delivered.

## **Article 9 - Billing and Payment**

### **9.1 Billing.**

(A) The billing period under this PPA shall be the calendar month.

(B) As soon as practicable and in any event within 20 Days after the end of each month, Company shall provide to Seller a statement containing Company's calculation of the amount due to Seller for such month, including the applicable billing parameters based upon Company's reading of the Electric Metering Devices consistent with Section 5.2.

(C) No later than 15 Business Days following receipt of Company's billing statement, Seller shall submit an invoice to Company in a form and by a method to be agreed by the Parties, showing the amount due Seller for the relevant month,

specifying the products and services provided, all billing parameters, rates and factors, and any other data relevant to the calculation of payments due to Seller. Such invoice shall include an explanation of any items in dispute, as well as all supporting documentation upon which Seller relies.

9.2 Payment. All payments shall be remitted via check or electronic funds transfer, as designated by the owed Party, on or before the 15<sup>th</sup> Business Day following receipt of the invoice. Remittances received by mail will be considered to have been paid when due if the postmark indicates the payment was mailed on or before the 15<sup>th</sup> Business Day following receipt of the billing invoice.

(A) If a payment is late, a late payment charge shall be applied to the unpaid balance for the number of days payment was late and shall be added to the next billing statement. Late payment charges shall include interest calculated using the prime rate of interest as published on the date of the invoice in *The Wall Street Journal* (or, if unavailable, an equivalent publication on or about that date).

(B) Company at any time may offset against amounts owed to Seller, any liquidated amounts, accrued damages and other payments, and undisputed billing errors and adjustments, which are owed by Seller to Company.

(C) Seller and Company may and shall net their obligations to each other under this PPA, and payment of the net amount shall discharge all mutual undisputed obligations between the Parties.

9.3 Billing Disputes. Either Party may dispute invoiced amounts pursuant to Section 13.1, but shall pay to the other Party at least the portion of invoiced amounts that is not disputed, on or before the invoice due date. When the billing dispute is resolved, the owing Party shall pay the amount owed within five (5) Business Days of the date of such resolution, with late payment interest charges calculated on the amount owed in accordance with Section 9.2(A).

## **Article 10 - Operations and Maintenance**

### **10.1 Operation and Administration**

(A) Seller shall staff, control, and operate the Facility consistent with Good Utility Practices, Exhibit I – AGC Protocols; Data Collection; Technical Specifications and this PPA. Personnel of Seller shall be available 24x7 via telephone or other electronic means with (i) the capability of remotely starting, operating and stopping the Facility within 10 minutes, and (ii) the ability to be present at the Site within 30 minutes.

(B) Seller shall comply with Good Utility Practices, the requirements of all Governmental Authorities and all reasonable requirements of Company in the operation of the Facility. By way of example only, Seller shall perform all capacity

testing of the Facility and related reporting, as and when required by Governmental Authorities.

(C) Seller shall provide to Company a day-ahead availability forecast in accordance with Exhibit I - AGC Protocols; Data Collection; Technical Specifications and any other reporting requirements required for compliance with NERC reliability standards. Company shall forward Seller's forecast to the applicable local reliability coordinator on Seller's behalf, *provided, however*, that Seller shall remain responsible to ensure the timeliness and accuracy of forecasts and any changes to the real-time or forecast availability of the Facility. If and to the extent that the ERO modifies the forecasting or other reporting requirements imposed on Company or the Facility, Seller shall timely provide required data to Company or the ERO, as applicable.

#### 10.2 Facility Maintenance.

(A) Seller shall maintain the Facility in accordance with Good Utility Practice. Seller shall coordinate its regular maintenance requirements for the Facility with Company ("Maintenance Schedules"). Maintenance Schedules shall be provided to Company in writing and sufficiently in advance for Commercially Reasonable review, and shall be subject to Company's Commercially Reasonable approval.

(B) Seller shall minimize the amount of scheduled maintenance during the months of January, February, June, July, August, September and December to the maximum extent consistent with Good Utility Practices. Seller shall coordinate with Company and the Transmission Authority the timing and duration of planned outages.

(C) When Forced Outages occur, Seller shall notify Company's EMCC of the existence, nature, start time, and expected duration of the Forced Outage as soon as practical, but in no event later than one hour after the Forced Outage occurs. Seller shall immediately inform Company's EMCC of changes in the expected duration of the Forced Outage except to the extent relieved of this obligation by Company's EMCC with respect thereto.

#### 10.3 Books and Records.

(A) Seller shall maintain an accurate and up-to-date operating log at the Facility, in electronic format, with records of production for each clock hour; changes in operating status; Forced Outages; information required by Governmental Authorities in the prescribed format; and other information reasonably requested by Company.

(B) Seller and Company shall each keep complete and accurate records and all other data required by each of them for the purposes of proper administration of this PPA, including metering, billing and payment records, and such records as may be required by Governmental Authorities. Originals or copies of all Operating Records shall be maintained at the Facility or such other [Texas or New Mexico] location as may be specified by Seller from time to time. Company may examine and make copies of such Operating Records from time to time upon request, during normal business hours.

10.4 Access to Facility. Representatives of Company shall have access to the Facility from time to time, on Commercially Reasonable prior notice, to read meters, perform inspections and take such other actions as may be appropriate to facilitate Company's performance of this PPA. While at the Facility, such representatives shall observe Seller's standard safety precautions and shall conduct themselves in a manner that will not interfere with operation of the Facility.

10.5 Real Time Data.

(A) Seller shall communicate all data necessary for Company to integrate the Facility into Company's EMCC in real time through the Facility's SCADA System in accordance with Exhibit I - AGC Protocols; Data Collection; Technical Specifications. Seller shall maintain the Facility's SCADA System so that it is capable of interfacing with and reacting to Company's AGC Set-Point and responding to signals from the Company's EMCC in accordance with the AGC Protocols.

(B) Seller shall use Commercially Reasonable Efforts to adjust the real time Park Potential of the Facility when Company communicates to Seller a measured difference of plus or minus two percent between the metered Renewable Energy and Park Potential, during periods when generation is not curtailed.

(C) From and after the Commercial Operation Date, Seller shall provide Company, at Seller's expense, real time performance and meteorological data for all Wind Turbines and meteorological towers at the Facility in accordance with Exhibit I - AGC Protocols; Data Collection; Technical Specifications for the Term of this PPA. Seller shall maintain Seller-owned data collection systems that are compatible with Company's PI System. Seller shall ensure that real time communications capabilities are available and maintained for transmission to Company's PI System. Seller shall ensure that all meteorological equipment at a minimum meets the specifications set forth in Exhibit I - AGC Protocols; Data Collection; Technical Specifications. Company shall have the right to disclose data gathered through the Company's PI System publicly; *provided, however*, that such data is (i) masked to obscure the origin of the data and (ii) aggregated so that the data cannot be correlated and used by competitors of Seller and/or the supplier of the Wind Turbines.

10.6 Accreditation. Seller shall perform from time to time, at its expense, any reporting and testing (including capacity testing) of the Facility required by Governmental Authorities.

10.7 Operating Committee and Operating Procedures.

(A) Company and Seller shall each appoint one representative and one alternate representative to act as the Operating Committee in matters relating to the Parties' performance obligations under this PPA and to develop operating arrangements for the generation, delivery and receipt of Renewable Energy from the Facility. The Parties' initial representatives on the Operating Committee are set forth in Exhibit D - Notices.

(B) The Operating Committee may develop mutually agreeable written Operating Procedures consistent with the requirements of this PPA, to address matters such as day-to-day communications; key personnel; operations-center interface; metering, telemetering, telecommunications, and data acquisition procedures; operations and maintenance scheduling and reporting; reports; operations log; testing procedures; and such other matters as may be mutually agreed upon by the Operating Committee.

(C) The Operating Committee shall review the requirements for AGC and Data Collection from time to time after the date hereof and may agree on modifications thereto to the extent necessary or convenient for operation of the Facility in accordance with this PPA.

(D) The Operating Committee shall have authority to act in all technical and day-to-day operational matters relating to performance of this PPA and to attempt to resolve potential disputes, *provided, however*, that except as explicitly provided herein, the Operating Committee shall have no authority to amend or waive any provision of this PPA.

## **Article 11 - Security for Performance**

### **11.1 Security Fund.**

(A) During the Term of this PPA, Seller shall fund and maintain security in favor of Company, at Seller's expense, to secure Seller's obligations to Company under this PPA (the "Security Fund"), in accordance with this Article 11.

(B) Seller shall establish and fund the initial Security Fund in the amount of *[insert \$125/kW multiplied by the number of kW in the Facility Nameplate Capacity]*, no later than 30 Days following the date of this PPA. Within 5 Business Days following COD, the amount of the Security Fund shall be reduced to *[insert \$75/kW multiplied by the number of kW in the Facility Nameplate Capacity]*.

(C) Company may draw from the Security Fund such amounts as are necessary to recover amounts owing to Company pursuant to this PPA, including any Liquidated Delay Damages, Actual Damages, liquidated damages for failure to achieve COD, and any amounts for which Company is entitled to indemnification under this PPA. Company may, in its sole discretion, draw all or any part of such amounts from any form of security to the extent available pursuant to this Article 11 and in any sequence Company may select. Company's failure or delay to draw any amount from the Security Fund in any instance shall not prejudice Company's rights to subsequently recover such amount from the Security Fund or in any other manner.

(D) Company shall notify Seller within 5 Business Days following any draw on the Security Fund by Company, including the amount thereof and the basis therefor.

## 11.2 Replenishment.

(A) Within 15 Days following each draw by Company on the Security Fund in respect of damages described in Section 12.4(B), Seller shall replenish the Security Fund by an amount equal to such draw.

(B) Within 15 Days following any other draw by Company on the Security Fund, Seller shall replenish the Security Fund by the amount of such draw, provided that the aggregate amount of replenishments under this Section 11.2(B) shall not exceed the Damage Cap.

## 11.3 Form.

(A) The Security Fund may be in the form of an irrevocable standby letter of credit substantially in the form of Exhibit G – Form of Letter of Credit (a "Letter of Credit") from a financial institution acceptable to Company ("Issuer").

1. The Issuer of the Letter of Credit shall have and maintain a Credit Rating equivalent to A- (or better) by Standard & Poors and A3 (or better) from Moodys. If such Credit Rating is A- or A3, the Issuer must not be on credit watch by any rating agency.

2. The Letter of Credit must be for a minimum term of 360 Days. Seller shall give Company at least 30 Days advance notice prior to any expiration or earlier termination of the Letter of Credit. Seller shall cause the renewal or extension of the Letter of Credit for additional consecutive terms of 360 Days or more (or, if shorter, the remainder of the Term) more than 30 Days prior to each expiration date of the security. If the Letter of Credit is not renewed or extended at least 30 Days prior to its expiration date or otherwise is terminated early, Company shall have the right to draw immediately upon the Letter of Credit and to place the amounts so drawn, at Seller's cost and with Seller's funds, in an Escrow Account in accordance with paragraph (B) below, until and unless Seller provides a substitute form of security meeting the requirements of this Section 11.3.

(B) The Security Fund may be in the form of U.S. currency deposited into an escrow account with a state- or federally-chartered commercial bank with an office in the State of [Texas or New Mexico, as applicable], with net assets of at least \$1 billion (the "Escrow Account").

1. The Escrow Account shall be governed by an escrow agreement in form mutually satisfactory to Seller, Company and the escrow agent, provided that (a) Company shall hold a first and exclusive perfected security interest in the funds in the Escrow Account, (b) Company shall be permitted unilaterally to draw down any amount therein, regardless of any protest by Seller or any other party liable thereon (*provided* that nothing in the Escrow Agreement shall preclude any protest against Company by Seller, following any draw, that such draw did not comply with this Agreement), and (c) Seller shall pay all fees and expenses of the escrow agent.

2. Funds held in the Escrow Account may be invested as Seller may direct in any of the following:

- a money-market fund sponsored by the escrow agent;
- U.S. treasury obligations with a maturity of 90 Days or less;
- commercial paper rated “A” or better, with a maturity of 90 days or less; and
- other liquid investment-grade investments with maturities of three months or less, approved by Company in advance (such approval not to be unreasonably withheld or delayed).

3. All investment income on the Escrow Account shall be taxable to, and accrue for the benefit of, Seller. After the Commercial Operation Date, periodic sweeps by Seller for recovery of interest earned by the escrowed funds shall be allowed, and, at any time the balance in the Escrow Account exceeds the required amount of security, the escrow agent may remit any excess to Seller.

(C) Following COD, the Security Fund may consist of a guaranty substantially in the form of Exhibit H – Form of Guaranty, from a parent or other guarantor (“Guarantor”) with a minimum of net worth of at least \$250,000,000 and an Investment Grade Credit Rating (and if such Credit Rating is exactly equivalent to BBB-[S&P] / Baa3 [Moody’s], the Guarantor must not be on credit watch by any rating agency). If the Credit Rating of the Guarantor is downgraded below Investment Grade, put on credit watch, or an event occurs that (in the reasonable determination of Company) portends a Material Adverse Effect in the creditworthiness of the Guarantor, then Company may require Seller to convert the guaranty to a Security Fund instrument meeting the criteria set forth in either paragraph (A) or paragraph (B) above no later than 10 Days after notice from Company.

(D) Upon request by Seller, Company shall negotiate in good faith immaterial changes to Exhibit G – Form of Letter of Credit and/or Exhibit H – Form of Guaranty, provided that Seller shall pay or reimburse Company for the incremental direct expenses (including the fees and expenses of counsel) incurred by Company in connection therewith.

(E) Seller may change the form of the Security Fund at any time and from time to time upon Commercially Reasonable prior notice to Company, *provided, however*, that the Security Fund must at all times satisfy the requirements of this Article 11.

11.4 Replacement. In the event that the Security Fund ever fails to comply with the requirements of this Article 11 or Company determines in a commercially reasonable manner that an event has occurred or circumstances have developed that threaten to cause the Security Fund to fail to comply with the requirements of this Article 11 (e.g. a Guarantor is placed on negative credit watch by a rating agency), Seller shall



be required to replace the Security Fund with security in compliance with Section 11.3 within 5 Days following notice thereof from Company.

11.5 Survival. The Security Fund shall survive termination of this PPA to be available to pay any amounts owed to Company arising prior to or upon termination. Promptly following (i) the end of the Term and the completion of all of Seller's obligations under this PPA, or (ii) termination of this PPA for any reason prior to the Scheduled Termination Date, Company shall determine the amount, if any, owed by Seller for any obligations or damages arising out of this PPA. Company may draw such amount and shall release the balance of the Security Fund (including any accumulated interest, if applicable) to Seller.

11.6 Expenses. Seller shall reimburse Company for its direct expenses (including the fees and expenses of counsel) incurred by Company in connection with the preparation, negotiation, execution and/or release (including making a draw of funds) of the Security Fund under this Article 11.

## **Article 12 - Default and Remedies**

### **12.1 Default by Seller: General**

(A) Events. Any of the following events shall constitute a default by Seller under this PPA. If no cure period is provided below, such default shall be deemed an Event of Default by Seller immediately upon its occurrence. If a cure period is provided below, such default shall mature into an Event of Default if not cured within the indicated cure period, subject to Section 13.3 below.

1. Seller's application for, or consent (by admission of material allegations of a petition or otherwise) to, the appointment of a receiver, trustee or liquidator for Seller or for all or substantially all of its assets, or its authorization of such application or consent, or the commencement of any proceedings seeking such appointment without such authorization, consent or application, which proceedings continue undismissed or unstayed for a period of 60 Days from inception.

*Cure Period:* None.

2. Seller's authorization or filing of a voluntary petition in bankruptcy or application for or consent (by admission of material allegations of a petition or otherwise) to the application of any bankruptcy, reorganization, readjustment of debt, insolvency, dissolution, liquidation or other similar law of any jurisdiction or the institution of such proceedings against Seller without such authorization, application or consent, which proceedings remain undismissed or unstayed for 60 Days from its inception or which result in adjudication of bankruptcy or insolvency within such time.

*Cure Period:* None.

3. Seller's assignment of this PPA or the Facility, or any Change of Control, not permitted by Section 19.1.

*Cure Period:* None.

4. Any representation or warranty by Seller in this PPA that has a Material Adverse Effect on Seller's ability to perform this PPA is proven to have been false in any material respect when made.

*Cure Period:* None.

5. Seller's failure to establish and maintain the Security Fund as and in the amounts required under Article 11.

*Cure Period:* Five (5) Business Days after Company provides notice of Seller's failure.

6. Seller's failure to obtain and maintain insurance in scope and amounts required under Article 16.

*Cure Period:* Five (5) Business Days after Company provides notice of Seller's failure.

7. Seller's failure to make any payment to Company as and when required by this PPA, including Liquidated Delay Damages, Actual Damages, and any required indemnification.

*Cure Period:* 10 Business Days after the date Seller receives notice from Company that the amount is overdue.

8. Any representation or warranty by Seller in this PPA that has a Material Adverse Effect on Seller's ability to perform this PPA ceases to remain true during the Term, other than due to a change of law.

*Cure Period:* 30 Days after Company provides notice of such breach.

9. A breach by Seller of the Interconnection Agreement, which breach materially interferes with Seller's delivery of Renewable Energy to the Point of Delivery, Company's ability to accept Renewable Energy at the Point of Delivery, Company's ability to transmit Renewable Energy beyond the Point of Delivery, and/or otherwise has a Material Adverse Effect on Company.

*Cure Period:* 30 Days from the breach or the cure period allowed by the Interconnection Agreement (whichever is longer).

10. Beginning with the second Commercial Operation Year, the failure of the Facility to achieve an Availability Factor for any Commercial Operation Year (as determined pursuant to Exhibit M) of 85% or more.

*Cure Period:* Seller shall be deemed to have cured this default if, in the following Commercial Operation Year, the Facility achieves an Availability Factor for such Commercial Operation Year (again as determined pursuant to Exhibit M) of 90% or more.

11. The failure by Seller to perform or observe any other material obligation to Company under this PPA, unexcused by Force Majeure (other than failure to achieve COD, which is addressed in Section 12.2 below).

*Cure Period:* 30 Days after notice thereof shall have been given by Company; *provided*, that if such default is not reasonably capable of cure within such 30-Day period, Seller shall have such additional period of time (not to exceed 90 Days in any event) as is reasonably necessary for cure, so long as Seller initiates cure within such 30-Day period and diligently prosecutes the cure to conclusion thereafter.

(B) Remedies for Default. In connection with any default by Seller under this Section 12.1 (whether or not cured by Seller), Company may

1. Seek Actual Damages in such amounts and on such basis for the default as authorized by this PPA;
2. Offset against any payments due to Seller, any Actual Damages and other amounts due from Seller; and/or
3. Draw any Actual Damages and other amounts due from Seller, from the Security Fund.

(C) Termination for Event of Default. Upon and at any time following an Event of Default by Seller under this Section 12.1, in addition to its rights under Section 12.1(B) above, Company may terminate this PPA immediately upon notice to Seller, without penalty or further obligation to Seller. In connection with any such termination, Company may collect from Seller (subject to the Damage Cap) all Actual Damages arising from such Event of Default through the Scheduled Termination Date.

(D) Specific Performance. In addition to the other remedies specified herein, upon any Event of Default of Seller under this Section 12.1, Company may elect to treat this PPA as being in full force and effect and Company shall have the right to specific performance.

(E) Option to Acquire Facility upon Termination due to Seller Default. If Company terminates this PPA under this Section 12.1 following COD, then, at any time within 90 Days following such termination, Company may give notice to Seller of Company's intent to purchase the Facility from Seller (a "Preliminary Exercise Notice").

1. As soon as practicable following delivery of a Preliminary Exercise Notice, the Parties shall appoint an independent appraiser experienced in appraising utility-scale wind power generation facilities to determine the fair market value ("FMV") of the Facility. If the Parties cannot agree on the identity of the appraiser, the appraiser shall be selected by the Arbitration Service. Seller shall provide to the appraiser full access to the Facility and the Site, to Seller's contracts, books and records, and to relevant personnel of Seller, during normal business

hours. Such access shall include the right to conduct inspections and tests (including environmental testing of the Site and operating tests on the Facility) necessary or appropriate for the determination of FMV of the Facility. Company shall pay all fees and costs of the appraiser. The Parties shall direct the appraiser to use his/her best efforts to complete and deliver his/her appraisal to the Parties within 45 Days following his/her appointment.

2. Following delivery of a Preliminary Exercise Notice, Seller shall provide to Company full access to the Facility and the Site, to Seller's contracts, books and records, and to relevant personnel of Seller, during normal business hours. Such access shall include the right to conduct lien searches, surveys, inspections and tests (including environmental testing of the Site and operating tests on the Facility) necessary or appropriate for due diligence review of the Facility. All information obtained by Company from such investigations shall be deemed Confidential Information subject to Section 20.18. All inspections, testing and access to the Facility and the Site by Company and the appraiser shall comport with all of Seller's policies governing the use, operation, and maintenance of the Facility, including health, safety and environmental requirements.

3. Within 60 Days following receipt of an appraisal under this Section 12.1(E), Company may elect to purchase the Facility from Seller (a "Default Option"). If Company fails to notify Seller of Company's election within such 60-Day period, Company shall be deemed to have elected not to exercise the Default Option. If Company exercises the Default Option, the purchase price to be paid by Company for the Facility in connection with any exercise of the Option shall be the FMV of the Facility, as determined by the appraiser. Seller shall cooperate in all respects reasonably necessary for Company to exercise its Default Option rights

4. If Company exercises the Default Option, the Parties shall negotiate and execute a definitive contract for the transaction (the "PSA"), subject to clause (iv) below. The PSA shall include the terms and conditions set forth in Exhibit L – PSA Provisions. In the event that the Parties cannot agree on the final form of PSA, (i) the issue shall be submitted to "baseball" arbitration in [city in Texas or New Mexico, as applicable] before one arbitrator appointed by the Arbitration Service, i.e. each Party shall submit to the arbitrator a form of proposed PSA, and the arbitrator shall be required to select one of the two forms to be used as the PSA in the transaction, without compromise, as the arbitral award, (ii) the period for closing of the transaction shall be extended for the period required to complete arbitration, (iii) the Party whose form PSA is rejected shall pay the fees and costs of the Arbitration Service, and (iv) if Company's form of PSA is rejected, Company shall have 30 Days following such rejection to decide whether to execute and deliver Seller's form of PSA or abandon the transaction.

5. This Section 12.1(E) shall be specifically enforceable by Company, without bond and without the need to prove irreparable harm.

## 12.2 Default by Seller: Failure to Achieve COD.

(A) COD Delay. Seller shall be in default under this PPA if the Facility fails to achieve COD by the Target COD (“COD Delay”). Seller shall be liable to pay [insert \$250 per MW of Facility Nameplate Capacity] per Day (“Liquidated Delay Damages”) to Company as a liquidated damage and not a penalty, in lieu of Actual Damages, for any COD Delay. Except as provided in Section 12.2(C) below, the payment of Liquidated Delay Damages shall be Company’s sole and exclusive remedy for a COD Delay. Liquidated Delay Damages shall begin to accrue on the Day after the Target COD (as it may be extended due to Force Majeure) until the first to occur of COD or termination of this PPA pursuant to Section 12.2(C) below.

(B) Cure. Seller shall have a cure period of 45 days for its failure to achieve Commercial Operation by the Target COD, *provided, however,* that if during such period Seller provides a written opinion from a mutually-agreeable independent engineer that COD can reasonably be achieved within an additional 45 Day period, then the cure period shall be 90 Days after the Target COD to achieve Commercial Operation. The payment of accrued Liquidated Delay Damages shall be a condition to any such cure.

(C) Termination. Failure to cure a COD Delay within the applicable cure period set forth in Section 12.2(B) shall be an Event of Default by Seller. Upon such an Event of Default, Company may (i) terminate this PPA immediately upon notice to Seller, without penalty or further obligation to Seller except as to costs and balances incurred prior to the effective date of such termination, and (ii) in connection therewith, in addition to accrued Liquidated Delay Damages but in lieu of Actual Damages for the balance of the Term, collect from Seller liquidated damages therefor in the amount of [insert \$100/kW x Facility Nameplate Capacity].

## 12.3 Default by Company.

(A) Events. Any of the following events shall constitute a default by Company under this PPA. If no cure period is provided below, such default shall be deemed an Event of Default by Company immediately upon its occurrence. If a cure period is provided below, such default shall mature into an Event of Default if not cured within the indicated cure period, subject to Section 13.3 below.

1. Company’s application for, or consent (by admission of material allegations of a petition or otherwise) to, the appointment of a receiver, trustee or liquidator for Company or for all or substantially all of its assets, or its authorization of such application or consent, or the commencement of any proceedings seeking such appointment without such authorization, consent or application, which proceedings continue undismissed or unstayed for a period of 60 Days from inception.

*Cure Period:* None.

2. Company's authorization or filing of a voluntary petition in bankruptcy or application for or consent (by admission of material allegations of a petition or otherwise) to the application of any bankruptcy, reorganization, readjustment of debt, insolvency, dissolution, liquidation or other similar law of any jurisdiction or the institution of such proceedings against Company without such authorization, application or consent, which proceedings remain undismissed or unstayed for 60 Days from its inception or which result in adjudication of bankruptcy or insolvency within such time.

*Cure Period:* None.

3. Company's assignment of this PPA, not permitted by Section 19.2.

*Cure Period:* None.

4. Any representation or warranty by Company in this PPA that has a Material Adverse Effect on Company's ability to perform this PPA is proven to have been false in any material respect when made.

*Cure Period:* None.

5. Company's failure to make any payment to Company as and when required by this PPA, including invoiced amounts, Actual Damages and any required indemnification.

*Cure Period:* 10 Business Days after the date Company receives notice from Seller that the amount is overdue.

6. Any representation or warranty by Company in this PPA that has a Material Adverse Effect on Company's ability to perform this PPA ceases to remain true during the Term, other than due to a change of law.

*Cure Period:* 30 Days after Seller provides notice of such breach.

7. The failure by Company to perform or observe any other material obligation to Seller under this PPA, unexcused by Force Majeure.

*Cure Period:* 30 Days after notice thereof shall have been given by Seller; *provided*, that if such default is not reasonably capable of cure within such 30-Day period, Company shall have such additional period of time (not to exceed 120 Days in any event) as is reasonably necessary for cure, so long as Company initiates cure within such 30-Day period and diligently prosecutes the cure to conclusion thereafter.

(B) Remedies for Default. In connection with any default by Company (whether or not cured by Company), Seller may

1. Seek Actual Damages in such amounts and on such basis for the default as authorized by this PPA; and/or

2. Offset against any payments due to Company, any Actual Damages and other amounts due from Company.

(C) Termination for Event of Default. Upon an Event of Default by Company, in addition to its rights under Section 12.3(B) above, Seller may terminate this PPA immediately upon notice to Company, without penalty or further obligation to Company, and in connection therewith, collect from Company all Actual Damages arising from such Event of Default through the Scheduled Termination Date.

#### 12.4 Limitations on Damages.

(A) Except as otherwise provided in Section 12.4(B), Seller's aggregate financial liability to Company for Actual Damages following COD shall not exceed [insert \$75/kW x Facility Nameplate Capacity] (the "Damage Cap"). If at any time following COD, Company incurs damages in excess of the Damage Cap that Seller does not pay when billed by Company, Company shall have the right to terminate this PPA upon notice to Seller, without further obligation by either Party except as to costs and balances incurred prior to the effective date of such termination.

(B) Actual Damages payable by Seller arising out of any of the following events shall not be subject to the Damage Cap and shall not be credited against the Damage Cap:

1. damage to Company-owned facilities proximately caused by negligence, breach of this PPA or other misconduct by Seller, its directors, officers, employees and agents;

2. Seller's intentional misrepresentation or intentional misconduct in connection with this PPA or the operation of the Facility;

3. the sale or diversion by Seller to a third party of any capacity or energy from the Facility, excluding sales of Excess Energy under Section 8.2 and any sales in mitigation of damages;

4. Seller's failure (i) to maintain insurance coverages in the types and amounts required by this PPA or (ii) to apply any insurance proceeds as required by Section 16.4;

5. any claim for indemnification under this PPA;

6. any Environmental Contamination caused by Seller; or

7. damages incurred by Company in connection with any bankruptcy or insolvency proceeding involving Seller, including Company's loss of the benefit of its bargain due to rejection or other termination of this PPA in such proceeding.

(C) The Parties confirm that the express remedies and measures of damages provided in this PPA satisfy the essential purposes hereof. If no remedy or measure of damages is expressly herein provided, the obligor's liability shall be limited to all direct damages proximately caused by such default ("Actual Damages") incurred by the non-defaulting Party, provided that if Seller is the defaulting Party, Actual Damages recoverable by Company hereunder may include Replacement Power Costs. **Neither Party shall be liable to the other Party for consequential, incidental, punitive, exemplary, special, treble, equitable or indirect damages, lost profits or other business interruption damages regardless of whether the relevant cause of action arises from statute, in tort or contract** (except to the extent expressly provided herein); *provided, however*, that if either Party is held liable to a third party for such damages and the Party held liable for such damages is entitled to indemnification from the other Party hereto, the indemnifying Party shall be liable for, and obligated to reimburse the indemnified Party for all such damages.

(D) To the extent damages required to be paid hereunder are liquidated, the Parties acknowledge that actual damages would be substantial but difficult or impossible to determine, that otherwise obtaining an adequate remedy is inconvenient, and that the liquidated damages constitute a reasonable approximation of the harm or loss.

#### 12.5 Step-In Rights.

(A) Upon the occurrence of a default by Seller following COD that could be cured by Company's possession of the Facility, Company shall have the right, but not the obligation, to assume control and operate the Facility as agent for Seller (whether voluntary or involuntary) in accordance with Seller's rights, obligations, and interest under this PPA ("Step-In Rights"). Company shall give Seller and the Facility Lender at least 10 Days' notice in advance of exercising Company's Step-In Rights. Exercise of Step-In Rights *per se* shall not be deemed to cure the associated default, and shall not preclude or limit Company's right to exercise its other remedies against Seller under this PPA.

(B) Seller irrevocably appoints Company as Seller's attorney-in-fact for the exclusive purpose of executing such documents and taking such other actions as Company may reasonably deem necessary, appropriate or prudent to implement its Step-In Rights.

(C) Company acknowledges that Company may be required and shall relinquish or delay exercise of its Step-In Rights in the event that the Facility Lender elects to appoint a receiver, foreclose and/or otherwise obtain possession of the Facility under the Financing Documents. Seller shall not grant any person, other than the Facility Lender, a right to possess, assume control of, or operate the Facility in derogation of Company's Step-In Rights.



(D) Seller shall reimburse Company for its expenses and costs (including the fees and expenses of counsel) incurred by Company in connection with exercising its Step-In Rights ("Step-In Costs").

(E) During the period of Company's exercise of its Step-In Rights:

1. Company shall implement its Step-In Rights and operate the Facility in conformance with Good Utility Practice.

2. Company shall perform Seller's obligations in a manner consistent with Seller's duties under this PPA.

3. Seller shall retain legal title to and ownership of the Facility.

4. Seller shall make available at the Facility all documents, contracts, books, manuals, reports, and records required for Company to construct, operate, and maintain the Facility.

5. Seller shall give Company, its employees and contractors, unrestricted access to the Site and the Facility.

6. Seller shall cooperate in the implementation of Company's Step-In Rights.

7. Company shall devote the Renewable Energy generated and delivered from the Facility during such period towards satisfaction of Seller's obligations hereunder.

(F) During the period of Company's exercise of its Step-In Rights, Company shall purchase the Renewable Energy from the Facility as provided herein; *provided* that Company may withhold its Step-In Costs from payments due to Seller hereunder. In the event that net revenues due to Seller are insufficient to cover such Step-In Costs, Company may draw upon the Security Fund to cover such Step-In Costs.

(G) Company may relinquish its Step-In Rights at any time, on at least 15 Days notice to Seller and the Facility Lender. Company shall relinquish its Step-In Rights on the earliest of (i) termination of this PPA, or (ii) Seller's cure of the default that led to exercise of Company's Step-In Rights within the applicable cure period set forth herein.

(H) This Section 12.5 shall be specifically enforceable by Company, without bond and without the need to prove irreparable harm.

(I) Exercise of its Step-In Rights shall not constitute an assumption by Company of any liability of Seller.

12.6 Bankruptcy. This PPA grants each Party the contractual right to "cause the liquidation, termination or acceleration" of the transactions within the meaning of Sections 556, 560 and 561 of the U.S. Bankruptcy Code, as they may be amended superseded or replaced from time to time. Upon a bankruptcy, a non-defaulting Party

shall be entitled to exercise its rights and remedies under this PPA in accordance with the safe harbor provisions of the Bankruptcy Code set forth in, *inter alia*, Sections 362(b)(6), 362(b)(17), 362(b)(27), 362(o), 546(e), 548(d)(2), 556, 560 and 561, as they may be amended, superseded or replaced from time to time.

12.7 Cumulative Remedies. Except as explicitly provided to the contrary in this PPA, each right or remedy of the Parties provided for in this PPA shall be cumulative of and shall be in addition to every other right or remedy provided for in this PPA, and the exercise of one or more of the rights or remedies provided for herein shall not preclude the simultaneous or later exercise by such Party of any other rights or remedies provided for herein

12.8 Duty to Mitigate. Each Party shall use Commercially Reasonable Efforts to mitigate any damages it may incur as a result of a default by the other Party under this PPA.

### **Article 13 - Dispute Resolution**

#### 13.1 Negotiation.

(A) In the event of any dispute arising under or associated with the Parties' performance of this PPA (a "Dispute"), within 10 Business Days following notice by either Party (a "Dispute Notice"), (i) each Party shall appoint a representative, and (ii) the representatives shall meet, negotiate and attempt in good faith to resolve the Dispute quickly, informally and inexpensively.

(B) In the event the Parties' representatives cannot resolve the Dispute within 30 Days after the first meeting, either Party may request that consideration and resolution of the Dispute be transferred to senior management. Within 10 Days following such a request, each Party shall submit a written summary of the Dispute describing the issues and claims to a senior officer of each Party designated to address the Dispute. Within 10 Business Days after receipt of each Party's Dispute summaries, the designated senior managers for both Parties shall negotiate in good faith to resolve the Dispute. If such senior managers are unable to resolve the Dispute thereafter, either Party may seek available legal remedies, subject to Sections 13.3, 19.3 [and 19.5].

13.2 Time Bar. If no Dispute Notice has been issued within 18 months following the occurrence of events or circumstances giving rise to the Dispute (regardless of the actual knowledge of either Party of such events and circumstances), all claims related to such Dispute (including any allegations of billing errors) shall be deemed waived and the aggrieved Party shall thereafter be barred from proceeding thereon.

13.3 No Termination Pending Dispute Resolution. Notwithstanding Section 12.1 or Section 12.3 to the contrary:

(A) An Event of Default shall not be deemed to have occurred (and hence neither Party may terminate this PPA) for failure by the other Party to pay any amount(s) allegedly due totaling less than \$100,000, if (1) such amount(s) are disputed in good faith, (2) the Party alleged to owe such amount(s) promptly commences and diligently pursues resolution of the Dispute pursuant to Section 13.1, and (3) the owed amount (if any) is paid within 10 Business Days after all dispute resolution mechanisms are completed with respect thereto.

(B) An Event of Default by Seller shall not be deemed to have occurred (and hence Company may not terminate this PPA) for failure by Seller to pay any amount(s) allegedly due totaling \$100,000 or more, if

1. such amount(s) are disputed by Seller in good faith;
2. Seller promptly commences and diligently pursues resolution of the Dispute pursuant to Section 13.1;
3. Seller either holds an Investment Grade Credit Rating, or posts cash collateral to secure its obligations (if any) with respect to the disputed amount(s), in an amount equal to the amount(s) in dispute, under a mutually agreeable third-party escrow agreement, in addition to the Security Fund; and
4. the owed amount (if any) is paid by Seller within 10 Business Days after all dispute resolution mechanisms are completed with respect thereto.

(C) An Event of Default by Company shall not be deemed to have occurred (and hence Seller may not terminate this PPA) for failure by Company to pay any amount(s) allegedly due totaling \$100,000 or more, if

1. such amount(s) are disputed by Company in good faith;
2. Company promptly commences and diligently pursues resolution of the Dispute pursuant to Section 13.1;
3. Company either holds an Investment Grade Credit Rating, or posts cash collateral to secure its obligations (if any) with respect to the disputed amount(s), in an amount equal to the amount(s) in dispute, under a mutually agreeable third-party escrow and account control agreement; and
4. the owed amount (if any) is paid by Company within 10 Business Days after all dispute resolution mechanisms are completed with respect thereto.

13.4 Governing Law. The interpretation and performance of this PPA and all actions related hereto (whether sounding in contract, tort or otherwise), shall be governed and construed in accordance with the laws of the State of Texas or New Mexico, as applicable, exclusive of conflict of laws principles.

13.5 Venue. The Parties submit to the exclusive jurisdiction of the state courts of the State of Texas for purposes of resolving any Dispute hereunder, except as

provided in Section 19.3 [and Section 19.5]. Venue for any court proceedings shall lie exclusively in the Texas District Court for the County of Potter or, if jurisdictionally available, the U.S. District Court for the Northern District of Texas.

13.6 Waiver of Jury Trial. **Seller and Company each hereby knowingly, voluntarily and intentionally waive any rights they may have to a trial by jury** in respect of any litigation based hereon, or arising out of, under, or in connection with, this PPA or any course of conduct, course of dealing, statements (whether oral or written) or actions of Seller and Company related hereto and expressly agree to have any Disputes be adjudicated by a judge of the court having jurisdiction, without a jury, subject only to Sections 12.1(E), 19.3 [and 19.5].

#### **Article 14 - Force Majeure**

14.1 Definition. For purposes hereof, "Force Majeure" means an event or circumstance that prevents a Party from performing its obligations under this PPA, which event or circumstance (i) was not anticipated as of the date of this PPA, (ii) is not within the control of or the result of the fault or negligence of the Party claiming excuse, and (iii) which by exercise of due diligence and foresight could not reasonably have been avoided; *provided, however*, that Force Majeure shall not include:

- a. inability, or excess cost, to procure any equipment necessary to perform this PPA;
- b. acts or omissions of a third party (including vendors and contractors to Seller), unless such acts or omissions are themselves excused by reason of Force Majeure;
- c. failure timely to apply for, or diligently pursue, the Permits set forth on Exhibit F – Seller's Needed Permits hereto;
- d. mechanical or equipment breakdown or inability to operate, attributable to circumstances occurring within design criteria and normal operating tolerances of similar equipment;
- e. Environmental Contamination at the Site;
- f. changes in market conditions;
- g. changes of law; or
- h. labor strikes, slowdowns, work stoppages, or other labor disruptions.

By way of example only, "Force Majeure" includes any delay or failure by the Transmission Authority to perform its obligations under the Interconnection Agreement.

14.2 Applicability of Force Majeure. A Party shall be relieved of its obligations to perform this PPA and shall not be considered to be in default with respect to any obligation under this PPA if and to the extent such Party is prevented from fulfilling such obligation by Force Majeure, *provided, however*, that: (i) such Party gives prompt notice

describing the circumstances and impact of the Force Majeure; (ii) the relief from its obligations sought by such Party is of no greater scope and of no longer duration than is required by the Force Majeure; (iii) such Party proceeds with due diligence to overcome the Force Majeure and resumes performance of its obligations under this PPA as soon as practicable thereafter; and (iv) such Party provides notice upon conclusion of the Force Majeure.

#### 14.3 Limitations on Effect of Force Majeure.

(A) Force Majeure shall only relieve a Party of such obligations as are actually precluded by the Force Majeure.

(B) In no event will the existence of Force Majeure extend this PPA beyond its stated Term.

(C) If Force Majeure affecting Seller continues for a period of 90 consecutive Days or any 150 non-consecutive Days (with respect to Force Majeure occurring prior to COD) or for a period of 180 consecutive Days or any 270 non-consecutive Days (with respect to Force Majeure occurring after COD), Company may, at any time following the end of such period, terminate this PPA upon notice to Seller, without further obligation by either Party except as to costs and balances incurred prior to the effective date of such termination.

### **Article 15 - Representations and Warranties**

Each Party hereby represents and warrants to the other as follows, which representations and warranties shall be deemed to be repeated, if applicable, by each Party throughout the Term:

(A) Such Party is a valid separate legal entity, duly organized, validly existing and in good standing under Applicable Law. It is qualified to do business in the State in which the Facility is located and each other jurisdiction where the failure to so qualify would have a Material Adverse Effect on the business or financial condition of the other Party. It has all requisite power and authority to conduct its business, to own its properties, and to execute, deliver, and perform its obligations under this PPA.

(B) The Party's execution, delivery, and performance of all of its obligations under this PPA have been duly authorized by all necessary organizational action, and do not and will not:

1. require any consent or approval by any governing corporate or management body, other than that which has been obtained and is in full force and effect (evidence of which shall be delivered to the other Party upon its request);
2. violate any Applicable Law, the violation of which could have a Material Adverse Effect on the representing Party's ability to perform its obligations under this PPA;

3. result in a breach or constitute a default under the representing Party's formation documents, bylaws or equivalent, or under any agreement relating to its management or affairs, any indenture or loan or credit agreement, or any other agreement, lease, or instrument to which it is a party or by which it or its properties or assets may be bound or affected, the breach or default of which could reasonably be expected to have a Material Adverse Effect on the representing Party's ability to perform its obligations under this PPA; or

4. result in, or require the creation or imposition of any mortgage, deed of trust, pledge, lien, security interest, or other charge or encumbrance of any nature (other than as may be contemplated by this PPA) upon or with respect to any of the assets or properties of the representing Party now owned or hereafter acquired, the creation or imposition of which could reasonably be expected to have a Material Adverse Effect on the representing Party's ability to perform its obligations under this PPA.

(C) This PPA is a valid and binding obligation of the representing Party.

(D) The execution and performance of this PPA will not conflict with or constitute a breach or default under any contract or agreement of any kind to which the representing Party is a party or any judgment, order, or Applicable Law, applicable to it or its business.

(E) Within the meaning of the U.S. Bankruptcy Code, (i) this PPA constitutes a "master netting agreement," (ii) all transactions pursuant to this PPA constitute "forward contracts" or a "swap agreement," (iii) the representing Party is a "forward contract merchant" and "master netting agreement participant," and (iv) all payments made or to be made pursuant to this PPA constitute "settlement payments."

(F) Such Party is (i) an "eligible contract participant" as defined in the Commodity Exchange Act, as amended, 7 U.S.C. §1a(12), (ii) a "market participant" under applicable exchange and market rules; (iii) a producer, processor, or commercial user of, or a merchant handling, the commodity which is the subject of this PPA, or the products or by products thereof; and (iv) entering into this PPA solely for purposes related to its business as such.

## **Article 16 - Insurance**

16.1 Evidence of Insurance. No later than commencement of construction and thereafter at least five Days prior to each applicable expiration date, Seller shall provide Company with two copies of insurance certificates acceptable to Company evidencing that insurance coverages for the Facility are in force and in compliance with the specifications for insurance coverage set forth in Exhibit E - Insurance to this PPA. Such certificates shall

(A) name Company as an additional insured (except worker's compensation);

(B) provide that Company shall receive 30 Days prior written notice of non-renewal, cancellation of, or significant modification to any of the corresponding policies (except that such notice may be 10 Days for non-payment of premiums);

(C) provide a waiver of any rights of subrogation against Company, its Affiliates and their officers, directors, agents, subcontractors, and employees; and

(D) indicate that the Commercial General Liability policy has been endorsed as described above.

16.2 Policy Requirements. All policies shall be written with insurers with an AM Best rating of at least A-VII or a Standard & Poor's rating of at least A. All policies shall be written on an occurrence basis, except as provided in Section 16.4. All policies shall contain an endorsement that Seller's policy shall be primary in all instances regardless of like coverages, if any, carried by Company. Seller may satisfy its insurance requirements using any reasonable combination of primary and secondary coverage.

16.3 No Implied Limitation. Seller's liability under this PPA is not limited to the amount of insurance coverage required herein.

16.4 Term and Modification of Insurance.

(A) All insurance required under this PPA shall cover occurrences during the Term and for a period of two years after the Term. In the event that any insurance as required herein is commercially available only on a "claims-made" basis, such insurance shall provide for a retroactive date not later than the date of this PPA and such insurance shall be maintained by Seller for a minimum of six years after the Term.

(B) Company shall have the right, at times deemed appropriate to Company during the Term, to request Seller to modify the insurance minimum limits specified in Exhibit E - Insurance in order to maintain Commercially Reasonable coverage amounts. Seller shall make Commercially Reasonable Efforts to comply with any such request.

(C) If any insurance required to be maintained by Seller hereunder ceases to be reasonably available and commercially feasible in the commercial insurance market, Seller shall provide notice to Company, accompanied by a certificate from an independent insurance advisor of recognized national standing, certifying that such insurance is not reasonably available and commercially feasible in the commercial insurance market for electric generating plants of similar type, geographic location and capacity. Upon receipt of such notice, Seller shall use Commercially Reasonable Efforts to obtain other insurance that would provide comparable protection against the risk to be insured.

16.5 Application of Proceeds. Except to the extent otherwise required by the Financing Documents, Seller shall apply any casualty insurance proceeds to reconstruction of the Facility following any material casualty to the Facility that occurs more than eighteen (18) months prior to the Scheduled Termination Date.

## Article 17 - Indemnity

17.1 Indemnification: General. Each Party (the "Indemnifying Party") shall indemnify, defend and hold the other Party (the "Indemnified Party") harmless from and against all claims, demands, lawsuits (including citizen suits), losses, liabilities, fines, penalties, and expenses (including attorneys' fees) (generally, "Losses"), to the extent caused by

- a default under this PPA by the Indemnifying Party;
- a violation or alleged violation of Applicable Laws by the Indemnifying Party; and
- the negligence, intentional acts and other misconduct of the directors, officers, employees, or agents of the Indemnifying Party.

17.2 Indemnification: Environmental. Seller shall indemnify, defend and hold Company harmless from and against all Losses arising out of any claim by any Governmental Authority or other third party alleging Environmental Contamination at the Site and/or illegal disposal of Hazardous Materials off-Site, regardless of merit and regardless of Seller's responsibility therefor.

### 17.3 Limitations.

(A) The foregoing indemnification obligations shall apply notwithstanding any contributory misconduct of the Indemnified Party, but the Indemnifying Party's liability to indemnify the Indemnified Party shall be reduced in proportion to the percentage by which the Indemnified Party's misconduct caused the damages.

(B) Neither Party shall be indemnified for Losses resulting from the sole negligence or willful misconduct of the directors, officers, employees, or agents of such Party.

(C) These indemnity provisions shall not be construed to relieve any insurer of its obligation to pay claims consistent with the provisions of a valid insurance policy. Nothing in this Article 17 shall enlarge or relieve Seller or Company of any liability to the other for any breach of this PPA.

### 17.4 Procedures.

(A) Promptly after receipt by a Party of any claim or notice of the commencement of any action, administrative, or legal proceeding, or investigation as to which the indemnity provided for in this Article 17 may apply, the Indemnified Party shall provide notice thereof to the Indemnifying Party; *provided* that a delay in providing such notice shall limit the obligations of the Indemnifying Party only to the extent that such delay actually prejudices the ability of the Indemnifying Party to contest the claim or defend the proceeding.



(B) The Indemnifying Party shall assume the defense thereof with counsel designated by such Party and satisfactory to the Indemnified Party, *provided, however,* if the defendants in any such action include both the Indemnified Party and the Indemnifying Party, and the Indemnified Party shall reasonably conclude that there may be legal defenses available to it which are different from or additional to, or inconsistent with, those available to the Indemnifying Party, the Indemnified Party shall have the right to select and be represented by separate counsel, at the Indemnifying Party's expense.

(C) If an Indemnifying Party fails to assume the defense of a claim meriting indemnification, the Indemnified Party may contest, settle, or pay such claim at the expense of the Indemnifying Party, *provided, however, that* settlement or full payment of any such claim may be made only following consent of the Indemnifying Party or, absent such consent, written opinion of the Indemnified Party's counsel that such claim is meritorious or otherwise warrants settlement.

17.5 Amounts Owed. In the event that a Party is obligated for indemnification under this Article 17, the amount owing to the Indemnified Party will be the amount of the Indemnified Party's actual loss net of any insurance proceeds received by the Indemnified Party following a Commercially Reasonable effort by the Indemnified Party to obtain such insurance proceeds.

## **Article 18 - Lender Provisions**

### 18.1 Accommodation of Facility Lender.

(A) Company shall provide such consents to collateral assignment, certifications, representations, estoppels, information or other documents, as may be reasonably requested by Seller in connection with the financing of the Facility consistent with the terms set forth in Exhibit K – Lender Consent Provisions (generally, a "Lender Consent"), *provided, however,* that in providing a Lender Consent, Company shall have no obligation to

1. modify the terms of this PPA;
2. provide any consent or enter into any agreement that has a Material Adverse Effect on any of Company's rights, benefits, risks, or obligations under this PPA;
3. transfer or release any property or property interests of Company;
4. release or subordinate (or cause the release or subordination) of any lien on any property of Company for the benefit of Seller or the Facility Lender; or
5. permit any lien to be placed on property of Company.

(B) Seller shall reimburse, or shall cause the Facility Lender to reimburse, Company for the direct expenses (including the fees and expenses of counsel) incurred by Company in the preparation, negotiation, execution and/or delivery of each Lender Consent and any documents requested by Seller or the Facility Lender pursuant to this Section 18.1.

#### 18.2 Notices.

(A) Seller shall provide Company with a notice identifying the Facility Lender and providing appropriate contact information for the Facility Lender. Following receipt of such notice, Company shall provide to the Facility Lender a copy of each notice of alleged default delivered to Seller under Section 12.1 or Section 12.2, and Company will accept a cure thereof performed by the Facility Lender, so long as the cure is accomplished within the applicable cure period set forth in this PPA or the relevant Lender Consent.

(B) Within 10 Days following Seller's receipt of each notice of default or Facility Lender's intent to exercise any remedies under the Financing Documents, Seller shall deliver a copy of such notice to Company.

### **Article 19 - Assignment**

#### 19.1 Assignment by Seller.

(A) Seller shall not sell, exchange or otherwise transfer the Facility or any material portion thereof to any third party, nor shall Seller undergo any Change of Control (whether voluntary or by operation of law), absent the prior written consent of Company, which shall not be unreasonably withheld or delayed. Company shall have no obligation to provide any consent under this Section unless

1. Seller has complied with Sections 19.3, 19.4 [and 19.5], if and as applicable;

2. Seller has provided to Company such information concerning the transferee's direct and indirect ownership as Company reasonably requests;

3. the transferee has substantial experience in the operation of power generation facilities akin to the Facility, either directly, through its affiliates or through an operator acceptable to Company;

4. the transferee (together with its parents and affiliates) enjoys an Investment Grade Credit Rating or other creditworthiness satisfactory to Company;

5. Seller has provided to Company at least 30 days' prior notice of the transaction; and

6. Seller pays or reimburses Company for the direct expenses (including the fees and expenses of counsel) incurred by Company in connection with the transaction.

(B) Any Change of Control or sale, transfer, or assignment of any interest in the Facility effected without fulfilling the requirements of this PPA shall be null, void and a breach of this PPA.

(C) Seller shall assign this PPA to any successor owner of the Facility, and shall cause such successor to assume all obligations of Seller (accrued and prospective) hereunder via a writing reasonably satisfactory to Company. Seller also may assign this PPA for collateral purposes to any Facility Lender, and may subcontract some or all of its duties under this PPA, upon notice to but without the consent of Company

(D) Except as permitted in this Section 19.1, Seller may not assign this PPA or any portion hereof. No assignment shall relieve Seller of its obligations under this PPA, nor impair any security posted by Seller unless such security is replaced in accordance with Article 11. Before this PPA is assigned by Seller, the assignee must first obtain such approvals as may be required by all applicable Governmental Authorities.

## 19.2 Assignment by Company.

(A) Company may assign this PPA to any Affiliate, or to any successor that provides retail electric service in all or substantially all of Company's service territory and is subject to rate and quality service regulation under the jurisdiction of the State Regulatory Agency. Any other assignment of this PPA by Company shall require the prior written consent of Seller, not to be unreasonably withheld or delayed.

(B) If an assignee of Company enjoys a Credit Rating equal to or better than Investment Grade or Company's Credit Rating as of the date of assignment (whichever is higher), Seller shall release Company from its obligations hereunder if so

requested by Company. Except for the foregoing, no assignment shall relieve Company of its obligations under this PPA.

(C) Any assignee of Company shall assume all obligations of Company (accrued and prospective) hereunder via a writing reasonably satisfactory to Seller. Before this PPA is assigned by Company, the assignee must first obtain such approvals as may be required by all applicable Governmental Authorities.

### 19.3 ROFO.

(A) At any time after the Commercial Operation Date,

- (1) if Seller proposes to sell the Facility to an unaffiliated third party, Seller shall first offer to sell the Facility to Company via notice to Company,
- (2) if Seller's parent proposes to sell a majority of the equity interests in Seller to an unaffiliated third party, Seller shall cause its parent first to offer to sell such equity interests to Company via notice to Company, and
- (3) if Seller's parent owns no assets other than its equity interests in Seller and the parent of Seller's parent proposes to sell a majority of the equity interests in Seller's parent to an unaffiliated third party, Seller shall cause its parent's parent first to offer to sell such equity interests to Company via notice to Company

(in each case, a "ROFO Notice") Any ROFO Notice shall describe the proposed transaction, including the minimum price, status of title to the Site, liabilities to be assumed and other terms which Seller or its relevant parent (as applicable) is willing to accept to proceed with the contemplated transaction. The contents of a ROFO Notice shall be deemed Confidential Information for purposes of Section 20.18 below.

(B) Following issuance of a ROFO Notice, Seller shall allow Company 60 Days to investigate the proposed transaction and conduct due diligence. Due diligence shall include such physical inspections, surveys and operating tests of the Facility and the Site, such reviews of Seller's contracts, books and records, and interviews of such personnel, as Company may reasonably request. All information obtained by Company from such investigations shall be deemed Confidential Information subject to Section 20.18 below. Within such 60-Day period, Company may elect to purchase the Facility or the relevant equity interests (as applicable) on substantially the same terms as set forth in the ROFO Notice. If Company fails to notify Seller of Company's election within such 60-Day period, Company shall be deemed to have rejected the transaction.

(C) If Company elects to purchase the Facility or the specified equity interests (as applicable), the Parties shall negotiate and execute a definitive contract for the transaction (a "PSA"). The PSA shall include the price and other terms set forth in

the ROFO Notice and such other terms as are set forth in Exhibit P – PSA Provisions. In the event that the Parties cannot agree on the final form of PSA, (i) the issue shall be submitted to “baseball” arbitration in [*city in Texas or New Mexico, as applicable*] before one arbitrator appointed by the Arbitration Service, i.e. each Party shall submit to the arbitrator a form of proposed PSA, and the arbitrator shall be required to select one of the two forms to be used as the PSA in the transaction, without compromise, as the arbitral award, (ii) the period for closing of the transaction shall be extended for the period required to complete arbitration, and (iii) the Party whose form PSA is rejected shall pay the fees and costs of the Arbitration Service.

(D) If Company rejects the transaction described in a ROFO Notice, Seller shall have the right to sell the Facility (or Seller’s relevant parent shall have the right to sell the specified equity interests, as applicable) on terms not more favorable to Seller or its parent vs. the terms set forth in the ROFO Notice, at any time within the twelve-month period following issuance of the ROFO Notice. If Seller or its relevant parent fails to close a transaction on such terms within such 12-month period, any sale of the Facility or equity interests in Seller shall again be subject to this Section 19.3.

(E) This Section 19.3 shall be specifically enforceable by Company, without bond and without the need to prove irreparable harm.

(F) Seller shall cooperate in all respects reasonably necessary for Company to exercise its ROFO rights, and shall operate the Facility in the ordinary course of business following the date of issuance of a ROFO Notice.

#### 19.4 PFT.

(A) Seller shall give Company at least 90 Days’ prior notice (a “PFT Notice”) of any Pending Facility Transaction that does not otherwise trigger Company’s ROFO rights under Section 19.3, in order to provide Company with an opportunity to discuss and negotiate with Seller the possible sale of the Facility to Company. Any PFT Notice shall include a fair summary of Seller’s plans with respect to the Facility in connection with the proposed Pending Facility Transaction, to the extent then known by Seller. The contents of a PFT Notice shall be deemed Confidential Information for purposes of Section 20.18 below.

(B) Seller shall have no obligation to sell nor shall Company have any obligation to purchase the Facility, following any PFT Notice. Issuance of a PFT Notice shall not relieve Seller of its obligation to offer a ROFO to Company if and when applicable pursuant to Section 19.3. In the event that the transaction giving rise to the PFT Notice has not been completed within twelve months following a PFT Notice, Seller shall be required to resubmit a PFT Notice for such transaction.

(C) Any breach of this Section 19.4 shall entitle Company to liquidated damages from Seller in the amount of [*insert \$5 x number of kW of Nameplate Capacity*].

(D) For purposes hereof, a “Pending Facility Transaction” or “PFT” means:

1. any Change of Control of Seller;
2. the issuance by Seller or any of its Affiliates of a request for proposals or the response by Seller or any of its Affiliates to a request for proposal or similar process (e.g., auction) for the purchase or sale to any unaffiliated third party of any equity interests in Seller or the Facility, or any group(s) of assets or equity interests that includes the Facility;
3. the commencement by Seller or any of its Affiliates of substantive negotiations with any unaffiliated third party with respect to the sale of any equity interests in Seller or the Facility, or any group(s) of assets or equity interests that includes the Facility; or
4. the execution by Seller or any of its Affiliates of any letter of intent, memorandum of understanding or similar document, whether or not legally binding, which contemplates the sale or lease to an unaffiliated third party of any equity interests in Seller or the Facility or any group(s) of assets or equity interests that includes the Facility;

*provided, however,* that a PFT does not include (i) any financing or refinancing of the Facility Debt, (ii) any transaction among Affiliates of Seller, and/or (iii) any transaction for which Seller offers ROFO rights to Company under Section 19.3.

#### 19.5 Option.

(A) At any time between the 8<sup>th</sup> and 9<sup>th</sup> anniversaries of COD (the “First Option”), and at any time between the 16<sup>th</sup> and 17<sup>th</sup> anniversaries of COD (the “Second Option”), Company may give notice to Seller of Company’s intent to purchase the Facility from Seller (a “Preliminary Exercise Notice”).

(B) As soon as practicable following delivery of a Preliminary Exercise Notice, the Parties shall appoint an independent appraiser experienced in appraising utility-scale wind power generation facilities to determine the fair market value (“FMV”) of the Facility. If the Parties cannot agree on the identity of the appraiser, the appraiser shall be selected by the Arbitration Service.

1. Seller shall provide to the appraiser full access to the Facility and the Site, to Seller’s contracts, books and records, and to relevant personnel of Seller, during normal business hours. Such access shall include the right to conduct inspections, surveys and tests (including environmental testing of the Site and operating tests on the Facility) necessary or appropriate for the determination of FMV of the Facility.
2. Company shall pay all fees and costs of the appraiser.

3. The Parties shall direct the appraiser to use his/her best efforts to complete and deliver his/her appraisal to the Parties within two (2) months following his/her appointment.

(C) Following delivery of a Preliminary Exercise Notice, Seller shall provide to Company full access to the Facility and the Site, to Seller's contracts, books and records, and to relevant personnel of Seller, during normal business hours. Such access shall include the right to conduct lien searches, surveys, inspections and tests (including environmental testing of the Site and operating tests on the Facility) necessary or appropriate for due diligence review of the Facility. All information obtained by Company from such investigations shall be deemed Confidential Information subject to Section 20.18.

(D) All inspections, testing and access to the Facility and the Site by Company and the appraiser shall comport with all of Seller's policies governing the use, operation, and maintenance of the Facility, including health, safety and environmental requirements, and shall be conducted in a manner so as to minimize disruption in the operation of the Facility and to avoid any adverse economic impacts to Seller under this PPA.

(E) Within 60 Days following receipt of an appraisal under Section 19.5(B), Company may elect to purchase the Facility from Seller (an "Option"). If Company fails to notify Seller of Company's election within such 60-Day period, Company shall be deemed to have elected not to exercise the Option.

(F) If the Facility is subject to Facility Debt secured only by the Facility, the purchase price to be paid by Company for the Facility in connection with exercise of the First Option shall be the greater of

- the amount of Facility Debt as of the date of issuance of the Preliminary Exercise Notice, or
- the FMV of the Facility, as determined by the appraiser.

Otherwise the purchase price to be paid by Company for the Facility in connection with exercise of the First Option (and exercise of the Second Option, in all circumstances) shall be the FMV of the Facility, as determined by the appraiser.

(G) If Company exercises the Option, the Parties shall negotiate and execute a definitive contract for the transaction (the "PSA"). The PSA shall include the terms and conditions set forth in Exhibit L – PSA Provisions. In the event that the Parties cannot agree on the final form of the PSA, (i) the issue shall be submitted to "baseball" arbitration in [*city in Texas or new Mexico, as applicable*] before one arbitrator appointed by the Arbitration Service, i.e. each Party shall submit to the arbitrator a form of proposed PSA, and the arbitrator shall be required to select one of the two forms to be used as the PSA in the transaction, without compromise, as the arbitral award, (ii) the period for closing of the transaction shall be extended for the period required to complete arbitration, and (iii) the Party whose form PSA is rejected shall pay the fees and costs of the Arbitration Service.

(H) This Section 19.5 shall be specifically enforceable by Company, without bond and without the need to prove irreparable harm.

(I) Seller shall cooperate in all respects reasonably necessary for Company to exercise its Option rights, and shall operate the Facility in the ordinary course of business following the date of issuance of a Preliminary Exercise Notice.

19.6 Memo of Option. In connection with the Parties' execution and delivery of this PPA, the Parties are executing and Company is recording a Memorandum of Option memorializing Company's Default Option under Section 12.1(E), its ROFO rights under Section 19.3, and its Option rights under Section 19.5.

## Article 20 - Miscellaneous

### 20.1 Notices.

(A) Notices required by this PPA shall be in writing and addressed to the other Party at the addresses noted in Exhibit D - Notices, as either Party updates such addresses from time to time by notice to the other Party. Notices shall be deemed effective when receipt is acknowledged in writing by the counterparty (or absent such acknowledgement, when delivered via third-party messenger or via FedEx or other reputable overnight courier service). Any notice shall be deemed to have been received by the close of the Business Day on which it was delivered. Real-time or routine communications concerning Facility operations shall be exempt from this Section 20.1(A).

(B) The Parties recognize the need for accurate communications between them. Each Party consents to the recording of telephone conversations between their employees and representatives, related to the performance and administration of this PPA.

### 20.2 Taxes.

(A) Company shall purchase all Renewable Energy on a wholesale basis, for resale to Company's wholesale and retail customers. Company shall obtain and provide Seller with any certificates required by any Governmental Authority or otherwise reasonably requested by Seller to evidence that the deliveries of Renewable Energy hereunder are sales for resale.

(B) As between the Parties, Company shall be solely responsible for the payment of (1) any sales, use or equivalent taxes imposed by Governmental Authorities, whether now in existence or hereafter enacted, on the purchase of Renewable Energy hereunder at the Point of Delivery, and (2) any taxes imposed by Governmental Authorities, whether now in existence or hereafter enacted, on the transmission of Renewable Energy beyond the Point of Delivery.

(C) Subject to Section 20.2(B), Seller shall be solely responsible for any and all present and future taxes and other impositions of Governmental Authorities



relating to the construction, ownership or leasing, operation or maintenance of the Facility and the Site (including *ad valorem* taxes on the Facility and the Site), and any taxes imposed prior to the Point of Delivery with respect to the products and services to be sold and delivered to Company hereunder, whether calculated based upon cost, value, labor, capital, production, savings, green attributes or other parameters. Seller's prices under Article 8 are inclusive of such taxes and impositions during the Term, and Seller assumes the risk of changes in such taxes after the date hereof.

(D) The Parties shall cooperate to minimize tax exposure, *provided, however,* that neither Party shall be obligated to incur any financial burden to reduce taxes for which the other Party is responsible hereunder.

20.3 Applicable Laws. Each Party shall comply with all Applicable Laws (including the Transmission Authority Tariff), except for any non-compliance that (individually or in the aggregate) could not reasonably be expected to have a Material Adverse Effect on the other Party or on such Party's ability to perform this PPA.

(A) As applicable, each Party shall give all required notices, shall procure and maintain all Permits necessary for performance of this PPA, and shall pay its respective charges and fees in connection therewith.

(B) Each Party shall promptly disclose to the other Party, any violation of any Applicable Laws arising out of the Facility and/or performance of this PPA.

(C) Upon permanent cessation of generation from the Facility, Seller shall decommission and remove the Facility and remediate the Site as, if and when required by Applicable Laws.

(D) Seller acknowledges that as a government contractor Company is subject to Applicable Laws regarding equal employment opportunity and affirmative action, including 41 C.F.R. §60-1.4(a)(1-7). Such Applicable Laws may also be applicable to Seller as a subcontractor to Company. All such Applicable Laws shall be deemed to be incorporated herein as required by Applicable Law.

(E) Each Party assumes the risk of changes in Applicable Laws following the date hereof, that affect such Party's costs of ownership and operation of its assets, and its performance of this PPA, except as otherwise specifically set forth herein.

20.4 Fines and Penalties. Seller shall pay when due all fees, fines, penalties and costs incurred by Company, Seller and/or their agents, employees or contractors arising from noncompliance by Seller, its employees, or subcontractors with any provision of this PPA, or any contractual obligation, Permit or requirements of Applicable Law, except for such fines, penalties and costs that are being actively contested in good faith and with due diligence by Seller and for which adequate financial reserves have been set aside to pay such fines, penalties or costs in the event of an adverse determination

## 20.5 Rate Changes.

(A) The terms and conditions and the rates for service specified in this PPA shall remain in effect for the Term hereof. Neither Party shall seek (nor support any third party seeking) any prospective or retroactive change to the rates or terms of service under this PPA pursuant to Section 205, 206 or 306 of the Federal Power Act.

(B) The standard of review for changes to this PPA whether proposed by a Party, a non-party, or FERC acting *sua sponte* shall be the “public interest” standard of review set forth in *United Gas Pipe Line v. Mobile Gas Service Corp.*, 350 U.S. 332 (1956) and *Federal Power Commission v. Sierra Pacific Power Co.*, 350 U.S. 348 (1956) (aka the “Mobile-Sierra doctrine”), as interpreted in *Morgan Stanley Capital Group, Inc. v. Public Util. Dist. No. 1*, 128 S. Ct. 2733 (2008).

20.6 Certifications. Each Party shall deliver or cause to be delivered to the other Party certificates of its officers, accountants, engineers or agents as to matters as may be reasonably requested, and shall make available personnel and records relating to the Facility to the extent that the requesting Party requires the same in order to fulfill any regulatory reporting requirements, or to assist the requesting Party in litigation, including administrative proceedings before the State Regulatory Agency.

20.7 Disclaimer of Third Party Beneficiaries. In executing this PPA, Company does not and does not intend to extend its credit or financial support for the benefit of any Facility Lender or any other third party transacting with Seller. Nothing in this PPA shall be construed to create any duty to, or standard of care with reference to, or any liability to, any person not a party to this PPA.

## 20.8 Relationship of the Parties.

(A) This PPA shall not be interpreted to create an association, joint venture, or partnership between the Parties, nor to impose any partnership obligation or liability upon either Party. Except as specifically provided for in this PPA to the contrary, neither Party shall have any right, power, or authority to enter into any agreement or undertaking for, or act on behalf of, or to act as an agent or representative of, the other Party.

(B) Seller shall be solely liable for the payment of all wages, taxes, and other costs related to the employment of persons to perform such services, including all federal, state, and local income, social security, payroll, and employment taxes and statutorily mandated workers’ compensation coverage. None of the persons employed by Seller shall be considered employees of Company for any purpose; nor shall Seller represent to any person that he or she is or shall become a Company employee.

20.9 Survival of Obligations. Cancellation, expiration, or earlier termination of this PPA shall not relieve the Parties of obligations, including warranties, remedies, or indemnities, that by their nature should survive such cancellation, expiration, or termination, which obligations shall survive for the period of the applicable statute(s) of limitation.

20.10 Severability. In the event any of the terms, covenants, or conditions of this PPA, its Exhibits, or the application of any such terms, covenants, or conditions, shall be held invalid, illegal, or unenforceable by any court or administrative body having jurisdiction, all other terms, covenants, and conditions of the PPA and their application not adversely affected thereby shall remain in force and effect; *provided, however, that* Company and Seller shall negotiate in good faith to attempt to implement an equitable adjustment in the provisions of this PPA with a view toward effecting the purposes of this PPA by replacing the provision that is held invalid, illegal, or unenforceable with a valid provision the economic effect of which comes as close as possible to that of the provision that has been found to be invalid, illegal or unenforceable.

20.11 Complete Agreement; Amendments. The terms and provisions contained in this PPA constitute the entire agreement between Company and Seller with respect to the Facility and shall supersede all previous communications, representations, or agreements, either verbal or written, between Company and Seller with respect to the sale of Renewable Energy from the Facility. Any amendment of this PPA, or any waiver of any provision hereof, shall be evidenced by a writing signed by the Party/ies to be bound thereby.

20.12 Waiver. The failure of either Party to enforce or insist upon compliance with or strict performance of any of the terms or conditions of this PPA, or to take advantage of any of its rights hereunder, shall not constitute a waiver or relinquishment of any such terms, conditions, or rights, but the same shall be and remain at all times in full force and effect.

20.13 Binding Effect. This PPA is binding upon and shall inure to the benefit of the Parties hereto and their respective successors, legal representatives, and assigns.

20.14 Headings. Captions and headings used in this PPA are for ease of reference only and do not constitute a part of this PPA.

20.15 Counterparts. This PPA may be executed in counterparts, and each executed counterpart shall have the same force and effect as an original instrument.

20.16 Press Release. Upon the request of either Party, the Parties shall develop a mutually agreed joint press release to be issued describing the location, size and nature of the Facility, the term of this PPA, and other relevant factual information about the relationship.

20.17 Exhibits. Either Party may change the information in Exhibit D - Notices at any time by notice without the approval of the other Party. All other Exhibits may be changed to the extent allowed by specific provisions of this PPA or with the mutual consent of both Parties.

20.18 Confidentiality.

(A) For purposes hereof, "Confidential Information" means

1. information specifically designated as Confidential Information in this PPA; and

2. written information delivered by one Party to the other from time to time during the Term, which information is labeled prominently as “Confidential,” “Proprietary” or the like and specifically references this PPA.

*provided, however,* that “Confidential Information” shall not include information that

- (x) is publicly available as of the date hereof, or becomes publicly available during the Term through no fault of the recipient Party;
- (y) can be documented was independently developed by the recipient Party; and/or
- (z) is disclosed to the recipient Party from an ultimate source other than the protected Party, without breach of this PPA by the recipient Party.

(B) The recipient Party shall (i) maintain the confidentiality of all Confidential Information of the protected Party, using the same degree of care used by the recipient Party to protect its own Confidential Information (and in any event not less than a reasonable degree of care), and (ii) shall use Confidential Information only in connection with its performance of this PPA. Confidential Information may be disclosed by the recipient Party to its agents, employees, directors, officers, consultants, auditors, lenders and equity investors, subject to their acceptance of the obligations of confidentiality imposed hereby and for whose violations of this Section 20.18 the recipient Party shall be responsible.

(C) In the event that Confidential Information must be disclosed by Applicable Law (e.g. pursuant to subpoena or civil discovery) other than in connection with a State Regulatory Agency proceeding, the Party required to make disclosure shall notify the protected Party sufficiently in advance to allow the protected Party a reasonable opportunity to obtain a protective order or seek other remedies, prior to disclosure by the recipient Party. For the avoidance of doubt, this Section 20.18(C) shall be inapplicable to any disclosure of Confidential Information to a State Regulatory Agency, its staff, intervenors and/or consumer counsel, disclosure of which shall be uninhibited by this PPA.

*[remainder of this page intentionally left blank]*

IN WITNESS WHEREOF, the Parties have executed this PPA as of the date first set forth above.

*Seller:*

\_\_\_\_\_ [LLC]

By: \_\_\_\_\_  
[name and title]

*Company:*

Southwestern Public Service Company

By: \_\_\_\_\_  
[\_\_\_\_\_] as Vice President of Xcel  
Energy Services, Inc., its authorized agent

## EXHIBIT A DEFINITIONS

The following terms shall have the meanings set forth herein:

“Actual Damages” has the meaning set forth in Section 12.4(C).

“Affiliate” of any designated Person means any person or entity that directly or indirectly controls, is under the control of, or is under common control with, the designated Person by the power to direct or cause the direction of the management of the policies of designated Person, whether through ownership interest, by contract or otherwise.

“AGC” or “Automatic Generation Control” means the equipment and capability of an electric generation facility automatically to adjust the generation quantity within the applicable Balancing Authority with the purpose of interchange balancing and specifically, the Facility’s capability of accepting an AGC Set-Point electronically, and the automatic adjustment and regulation of the Facility’s energy production via the SCADA System.

“AGC Protocols” means the protocols for AGC included in Exhibit I - AGC Protocols; Data Collection; Technical Specifications, as such protocols may be modified from time to time in accordance with Section 10.7.

“AGC Remote/Local” means a handshake electronic signal sent from the Facility to the EMCC AGC system, and from the EMCC AGC system to the Facility, indicating the Facility is receiving AGC Set-Point locally (from the Facility) or remotely (EMCC AGC system) and is following that AGC Set-Point.

“AGC Set-Point” means the Company-generated analog or digital signal sent by the SCADA System to the Facility, representing the quantity of Renewable Energy to be generated by the Facility. The AGC Set-Point is calculated by the EMCC AGC system and communicated electronically to the Facility via the SCADA System.

“Applicable Law” means all laws, statutes, treaties, codes, ordinances, regulations, certificates, orders, licenses and permits of any Governmental Authority that are applicable to a Party, the business of a Party or the Facility, now in effect or hereafter enacted, including amendments to or interpretations of any of the foregoing by a Governmental Authority having jurisdiction, and all applicable judicial, administrative, arbitration and regulatory decrees, judgments, injunctions, writs, orders, awards and/or like actions.

“Arbitration Service” means Judicial Arbitration and Mediation Services, Inc. (aka JAMS).

“Availability Factor” shall have the meaning set forth in Exhibit M.

“Back-Up Metering” shall have the meaning set forth in Section 5.2(B).

“Balancing Authority” means the system of electrical generation, distribution and transmission facilities within which generation is regulated in order to maintain interchange schedules with other such systems.

“Business Day” means any Day that is not a Saturday, a Sunday, or a NERC recognized holiday.

“Change of Control” means the occurrence of any one of the following events with respect to Seller or any direct or indirect owner of a majority of the ownership interests in Seller: (a) a transfer of a majority of the ownership interests in Seller or such owner; (b) any consolidation or merger of Seller or such owner in which Seller or such owner, as the case may be, is not the continuing or surviving entity; or (c) a sale or conveyance of any direct or indirect ownership interest in Seller following which [REDACTED] (“Ultimate Parent”) is no longer the direct or indirect owner of at least 50% of the ownership interests of Seller, *provided, however*, that a Change of Control shall not be deemed to have occurred as a result of

- (i) transactions exclusively among Affiliates of Seller,
- (ii) any exercise by the Facility Lender of its rights and remedies under the Financing Documents,
- (iii) a change of control of Ultimate Parent, or
- (iv) any change of economic and/or voting rights triggered in Seller’s organizational documents arising from a tax-equity financing of the Facility.

“COD Conditions” means all of the requirements that must be satisfied by Seller as a prerequisite to achieving Commercial Operation. The COD Conditions are set forth in Section 4.5.

“Commercial Operation” means the period beginning on the Commercial Operation Date and continuing through the balance of the Term of this PPA.

“Commercial Operation Date” or “COD” shall have the meaning set forth in Section 4.5.

“Commercial Operation Year” shall have the meaning set forth in Section 4.5(E).

“Commercially Reasonable” or “Commercially Reasonable Efforts” means, with respect to any action to be taken or attempted by a Party under this PPA, the level of effort in light of the facts known to such Party at the time a decision is made that: (a) can reasonably be expected to accomplish the desired action at a reasonable cost; (b) is consistent with Good Utility Practices; and (c) takes into consideration the amount of advance notice required to take such action, the duration and type of action, and the competitive environment in which such action occurs.

“Committed Energy” from the Facility for each Commercial Operation Year is set forth on Exhibit J hereto. The amount of Committed Energy shall be deemed Confidential Information for purposes of Section 20.18.

“Compensable Curtailment” and “Compensable Curtailment Energy” shall have the meanings set forth in Section 8.3(B).

“Confidential Information” shall have the meaning set forth in Section 20.18(A).

“Construction Contracts” shall have the meaning set forth in Section 4.1.

“Construction Milestones” means the dates set forth in Exhibit B – Construction Milestones.

“Credit Rating” of any Person means the lowest rating assigned to such Person’s long-term debt or deposit obligations (unenhanced by third-party support) by Standard & Poors and Moody’s. If such Person has no outstanding long-term debt or deposit obligations, or if no rating is assigned to such obligations, “Credit Rating” shall mean the lowest general corporate credit rating or long-term issuer rating assigned to such Person by Standard & Poors or Moody’s.

“Damage Cap” shall have the meaning set forth in Section 12.4.

“Day” means a calendar day.

“Default Option” shall have the meaning set forth in Section 12.1(E).

“Dispute” shall have the meaning set forth in Article 13.

“Electric Metering Devices” means revenue quality meters, metering equipment and data processing equipment used to measure, record and transmit data with respect to the output of Renewable Energy from the Facility, including metering current transformers and metering voltage transformers.

“Eligible Energy Resource” means any generation resource eligible to be certified to generate, claim, own or use Renewable Energy Credits and green tags pursuant to the protocols and procedures developed and approved by applicable Government Authorities for the REC Registration Program.

“Energy Markets Control Center” or “EMCC” means Company's merchant representatives responsible for dispatch of generating units, including the Facility.

“Energy Payment Rate” shall have the meaning set forth in Exhibit J.

“Energy Resource Interconnection Service” means the type of interconnection service which allows Seller to connect the Facility to the transmission or distribution system, as applicable, as an “Energy Resource” as defined by the Transmission Tariff,



and be eligible to deliver the Facility's output using the existing firm or non-firm capacity on the transmission system on an as-available basis. *if needed*

"Environmental Contamination" shall have the meaning set forth in Section 4.2.

"ERO" means the Electric Reliability Organization certified by FERC pursuant to Section 215 of the Federal Power Act or any successor organization. The certified ERO as of the date of this PPA is the Electric Reliability Council of Texas ("ERCOT").

"Event of Default" shall have the meaning set forth in Article 12.

"Excess Energy" shall have the meaning set forth in Section 8.2.

"Facility" means Seller's electric generating facilities, associated balance of plant, parts, fixtures and equipment, and all equipment necessary to interconnect to the Transmission Authority's System, all as further described in Exhibit C - Facility Description, including Seller's rights to the Site and all of the following: buildings, turbines, generators, step-up transformers, output breakers, facilities necessary to connect to the Interconnection Point, protective and associated equipment, improvements, and other tangible and intangible assets, contract rights, Permits, easements, rights of way, surface use agreements and other interests or rights in real estate, owned or used for construction, operation, maintenance, generation and delivery of the capacity and energy subject to this PPA.

"Facility Debt" means the obligations of Seller or its Affiliates to any lender or tax equity investor pursuant to the Financing Documents, including principal of, premium and interest on indebtedness, fees, expenses or penalties, amounts due upon acceleration, prepayment or restructuring, swap or interest rate hedging breakage costs and any fees or interest due with respect to any of the foregoing.

"Facility Lender" means, collectively, any lenders or tax equity investors providing Facility Debt, including any successors or assigns thereof.

"Federal Power Act" means the provisions of 16 U.S.C. §791(A) *et seq.* and amendments or supplements thereto.

"FERC" means the Federal Energy Regulatory Commission or any successor agency.

"Financing Documents" means the loan and credit agreements, notes, bonds, indentures, security agreements, lease financing agreements, mortgages, deeds of trust, interest rate exchanges, swap agreements and other documents relating to the development, bridge, construction or permanent debt financing and/or tax equity financing for the Facility, including any credit enhancement, credit support, working capital financing, or refinancing documents, and any and all amendments, modifications, or supplements to the foregoing that may be entered into from time to

time at the discretion of Seller in connection with development, construction, ownership, leasing, operation or maintenance of the Facility.

“Forced Outage” means any condition at the Facility that requires the immediate and unplanned removal of the Facility, or at least ten percent thereof, from service, another outage state, or a reserve shutdown state, resulting from immediate mechanical/electrical/hydraulic control system trips and operator-initiated trips in response to abnormal Facility conditions or alarms.

“Good Utility Practices” means the practices, methods, standards and acts engaged in or approved by a significant portion of the applicable segment of the electric power generation industry pertaining to facilities of the type, similar size and location to the Facility that, at a particular time, in the exercise of Commercially Reasonable judgment, in light of the facts that are known (or reasonably should have been known) at the time a decision was made, would have been expected to accomplish the desired result in a manner consistent with Applicable Law, Permits, codes, standards, equipment manufacturer’s recommendations, reliability, safety, environmental protection, economy, and expedition. Good Utility Practices is not limited to the optimum practice, method, standard or act to the exclusion of all others, but rather to those practices, methods, standards and acts generally acceptable or approved by a significant portion of the applicable segment of the electric power generation industry in the relevant region, during the relevant period.

“Governmental Authority” means any federal, state, local or municipal governmental body; any governmental, quasi-governmental, regulatory or administrative agency, commission, body or other authority exercising or entitled to exercise any administrative, executive, judicial, legislative, policy, regulatory or taxing authority or power; and/or any court or governmental tribunal. By way of example only, “Governmental Authorities” include NERC, the ERO, the Market Operator (if any), an applicable State Regulatory Agency, the Transmission Authority and FERC, and successor organizations.

“Interconnection Agreement” means the separate contract for interconnection of the Facility to the Transmission Authority’s System, as such agreement may be amended from time to time. For purposes of this PPA, the Interconnection Agreement shall be interpreted to include any third party facility construction agreement or other agreement required by the Transmission Authority to interconnect the Facility in accordance with the Transmission Tariff. For the avoidance of doubt, “Interconnection Agreement” excludes any temporary or provisional interconnection agreement or any agreement where the Transmission Provider may limit the operational output of the Facility.

“Interconnection Facilities” means those facilities designated in the Interconnection Agreement for the direct purpose of interconnecting the Facility at the Interconnection Point, along with any easements, rights of way, surface use agreements and other interests or rights in real estate reasonably necessary for the construction, operation and maintenance of such facilities, whether owned by Seller,

the Transmission Authority or another entity. This equipment is conceptually depicted in Exhibit C - Facility Description to this PPA.

“Interconnection Point” means the physical point within the operational authority of the Transmission Authority as specified in the Interconnection Agreement as project [REDACTED], at which electrical interconnection is made between the Facility and the Transmission Authority’s System in accordance with the Transmission Tariff and the Interconnection Agreement.

“Investment Grade” means a Credit Rating of both (a) Baa3 or higher by Moody’s, and (b) BBB- or higher by Standard & Pools.

“kW” means kilowatt, and “kWh” means kilowatt hour.

“Lender Consent” shall have the meaning set forth in Section 18.1.

“Maintenance Schedule” has the meaning set forth in Section 10.2.

“Market Operator” means the entity that instructs market participants and/or generators to regulate generation assets (including the Facility) within any energy market in which Company participates, based on price-based offer curves for the purpose of matching generation output to system load demand while maintaining bulk electric system reliability. If such entity is the Transmission Authority, then “Market Operator” shall mean such entity acting in its capacity as such.

“Material Adverse Effect” means any effect (or effects taken together) that is materially adverse to the present or future business, operations, assets, liabilities, properties, results in operations or condition (financial or otherwise), prospects, or property of a Party, its business, or this PPA.

“MW” means megawatt or one thousand kW, and “MWh” means megawatt hours.

“Nameplate Capacity” of the Facility means the sum of the designed maximum outputs of each Wind Turbine comprising the Facility, as designated by the turbine manufacturer.

“NERC” means the North American Electric Reliability Council or any successor organization.

“Non-Compensable Curtailment” shall have the meaning set forth in Section 8.3(B).

“Operating Committee” means one representative each from Company and Seller, pursuant to Section 10.7.

“Operating Procedures” means those procedures developed by the Operating Committee pursuant to Section 10.7, if any.

“Operating Records” means all agreements associated with the Facility, operating logs, blueprints for construction, operating manuals, all warranties on equipment, and all documents, whether in printed or electronic format, that Seller uses or maintains for the operation of the Facility.

“Option” means Company’s rights to purchase the Facility on the terms and conditions set forth in Section 19.5.

“Park Potential” means the number of MW that depicts Seller’s real time calculation of the Potential Energy capable of being provided by the Facility to Company at the Point of Delivery. Park Potential shall be calculated using the best-available data obtained through Commercially Reasonable methods; and shall be dependent upon measured wind speeds, power curves, Wind Turbine availability, and derate(s) and transmission line losses, and any other adjustment necessary to accurately reflect the Potential Energy at the Point of Delivery. Park Potential should be provided to the Company in real time through the Company’s SCADA System in accordance with the AGC Protocols.

“Party” and “Parties” shall have the meanings set forth in the introductory paragraph.

“Pending Facility Transaction” or “PFT” shall have the meaning set forth in Section 19.4.

“Permit” shall have the meaning set forth in Section 4.3.

“PFT Notice” shall have the meaning set forth in Section 19.4.

“PI System” means the “plant information” system for the Facility, as described and implemented in Exhibit I - AGC Protocols; Data Collection; Technical Specifications.

“Point of Delivery” means the physical point within the operational authority of Transmission Authority at which Seller makes available and delivers to Company the Renewable Energy being provided by Seller to Company under this PPA. The Point of Delivery is specified in Exhibit C - Facility Description to this PPA.

“Potential Energy” for any period of time means the MWh of energy that the Facility is actually capable of delivering to the Point of Delivery by virtue of the Park Potential during such period.

“PTCs” means Production Tax Credits applicable to electricity produced from certain renewable resources pursuant to 26 U.S.C. §45, or such substantially equivalent tax credit that provides Seller with a tax credit based on energy production from the Facility.

“REC Registration Program” means the applicable State, regional, or federal program established to register Eligible Energy Resources such as the Facility, and create and certify RECs arising from energy generated from such Resources, including any rights associated with any renewable energy information or tracking system that exists or may be established by Applicable Law with regard to monitoring, registering, tracking, certifying, or trading such credits. For purposes of this PPA, the REC Registration program shall mean the Electric Reliability Council of Texas (aka ERCOT).

“Renewable Energy” means all electric energy generated by the Facility and delivered to Company at the Point of Delivery during the Term, including all Test Energy and any Excess Energy purchased by Company. “Renewable Energy” shall be deemed to include all RECs associated with such electric energy.

“Renewable Energy Credits” or “RECs” means the right to all non-energy and environmental attributes (including economic, carbon and pollutant-related tags and credits, benefits, avoided or reduced emissions reductions, offsets, emission rate reductions, tags and allowances, howsoever titled) attributable to the capacity available and/or energy generated by the Facility, including environmental air quality credits, tags and allowances created by Applicable Law by virtue of the Facility’s environmentally favorable or renewable characteristics or attributes. “RECs” includes but is not necessarily limited to rights eligible for registration, trading and/or use under the REC Registration Program. “REC” shall include renewable energy certificates within the meaning of Part 572 of Title 17, Chapter 9, New Mexico Administrative Code with respect to one MWh of Renewable Energy, and one MWh of Renewable Energy that is physically metered, verified in Texas and meets the requirements of subsection (a) of PUCT Substantive Rule 25.173, as applicable.

For the avoidance of doubt, “RECs” exclude (i) PTCs, ITCs and other local, state or federal tax credits providing a tax benefit to Seller based on ownership of the Facility or energy production therefrom, including the [production tax credit] that may be available to Seller with respect to the Facility under IRC §45, and (ii) depreciation and other tax benefits arising from ownership or operation of the Facility unrelated to its status as a generator of renewable or environmentally clean energy.

“Replacement Power Costs” for any period mean the costs incurred by Company to replace the products and services which Seller was required to provide under this PPA (but failed to so provide) during such period, less the sum of any payments from Company to Seller under this PPA that were eliminated with respect to such period as a result of such failure. Replacement Power Costs shall be determined on an hourly basis and shall equal the sum of the following for each hour where the following calculation achieves a positive number:

$$\text{Hourly Replacement Power Costs} = (A + B + C + D) - E, \text{ where}$$

“A” = the product of (x) the number of MW of lost capacity, derived by subtracting the number of MW of capacity of the Facility that qualifies for capacity credit actually made available to Company from the

amount of qualifying capacity associated with the entire Facility, and (y) the applicable market price for capacity made available to Company's system, for such hour;

"B" = the price paid by Company for the MWh of energy purchased by Company to replace the Contract Energy that was not delivered under this PPA during such hour;

"C" = the product of (x) the number of MWh of energy purchased by Company with respect to such hour, to replace the Committed Energy that was not delivered under this PPA, and (y) the actual cost of registered RECs for that number of MWh, for such hour;

"D" = the actual cost of transmission, ancillary services, fuel and fuel transportation, other incremental costs, and any related penalties that could not be avoided or mitigated, and transaction charges to deliver reasonably available energy to Company in amounts equal to the number of MWh for which Replacement Power Costs are owed; and

"E" = the sum of all payments avoided by Company as a result of Seller's breach, for such hour, including avoided payments under Article 8.

"ROFO" and "ROFO Notice" shall have the meanings set forth in Section 19.3.

"SCADA" means supervisory control and data acquisition.

"Scheduled Termination Date" shall have the meaning set forth in Article 2.

"Security Fund" shall have the meaning set forth in Section 11.1.

"Site" means the parcel of real property on which the Facility will be located, including any easements, rights of way, surface use agreements and other interests or rights in real estate necessary for the construction, operation and maintenance of the Facility. The Site is more specifically described in Exhibit C - Facility Description to this PPA.

"State Regulatory Agency" means the Public Utility Commission of Texas and/or the New Mexico Public Regulation Commission, or any successor agencies.

"State Regulatory Approval" means a written initial order of the State Regulatory Agency approving this PPA in such a manner that all costs incurred by Company under this PPA will be recoverable from retail customers in a timely manner through fuel clauses and, if applicable, base rates pursuant to Applicable Law subject only to the requirement that the State Regulatory Agency retain ongoing prudence review of Company's performance and administration of this PPA.

"Step-In Rights" shall have the meaning set forth in Section 12.5.

“Target COD” shall have the meaning set forth in Section 4.5(A).

“Term” means the period of time during which this PPA remains in full force and effect, as further defined in Article 2.

“Test Energy” shall have the meaning set forth in Section 4.6.

“Transmission Authority” means collectively those entities owning and/or operating the interconnected transmission system applicable to Seller and the Facility pursuant to a Transmission Tariff, including (i) Southwestern Public Service Company operating under and in accordance with its Transmission Tariff, and (ii) all entity(s) responsible under the Interconnection Agreement for providing the transmission lines, any Interconnection Facilities and other equipment and facilities with which the Facility interconnects at the Interconnection Point and transmission system.

“Transmission Authority’s System” means the contiguously interconnected electric transmission and sub-transmission facilities, over which the Transmission Authority has rights (by ownership or contract) to provide bulk transmission of capacity and energy from the Interconnection Point.

“Transmission Tariff” means the applicable Open Access Transmission Tariff of the Transmission Authority, as amended from time to time.

“Wind Turbine(s)” means the wind-energy generating devices that are included in the Facility. The manufacturer and model number of the Wind Turbines is identified on Exhibit C – Facility Description.

\* \* \* \* \*

**EXHIBIT B**  
**CONSTRUCTION MILESTONES**

**Construction**

<u>Milestone</u>	<u>Outcome</u>
<i>[Date]</i>	Seller and all required counterparties shall have executed such Construction Contracts as are needed to construct the Facility.
<i>[Date]</i>	Seller and the Transmission Authority shall have executed the Interconnection Agreement.
<i>[Date]</i>	Seller shall have achieved closing on financing for the Facility or provided Company with proof of financial capability to construct the Facility.
<i>[Date]</i>	Seller shall have laid the foundation for all Facility buildings, generating facilities and step-up transformation facilities.
<i>[Date]</i>	The Wind Turbines and step-up transformer shall have been delivered and installed at the Site.
<i>[Date]</i>	Seller's Interconnection Facilities shall have been constructed, and such facilities are capable of being energized.
<i>[Date]</i>	Start-up testing of the Facility commences.
<i>[Date]</i>	Seller shall make all applications and/or filings required by Applicable Law for REC accreditation and for the assignment of such RECs to Company.



## EXHIBIT C FACILITY DESCRIPTION AND SITE MAPS

***[This Exhibit shall include a description of the Facility and all material components thereof, including map, aerial pictures, one-line diagram, Point of Delivery and (if different) the Interconnection Point.]***

The Facility shall be located on the Site and shall be identified as Seller's [REDACTED] Generation Facility. Maps and one-line diagrams of the Facility and associated equipment are included as part of this Exhibit.

The address of the Facility is [REDACTED].

The Facility must include the following specific components:

- \* have the panel space and 125VDC battery supplied voltage necessary to accommodate the metering, telemetering and communications equipment required by the PPA;
- \* communication circuits from the Facility to the EMCC for the purpose of telemetering, supervisory control/data acquisition, and voice communications as required by Company;
- \* equipment and software necessary to receive, accept and react to an AGC signal from the Company's SCADA System and to comply with the AGC Protocols as further specified on Exhibit I - AGC Protocols; Data Collection; Technical Specifications;
- \* each Wind Turbine equipped with meteorological measurement equipment (e.g. anemometers), individually linked to Seller's information system;
- \* capability of sending real time data and OPC interface to Company's PI System;

**[Additional Bid Specific requirements to be added]**

**EXHIBIT D**  
**NOTICES AND CONTACT INFORMATION**

<u>Company</u>	<u>Seller</u>
<p><b>Notices:</b></p> <p>_____</p> <p>Renewable Purchased Power Manager  Xcel Energy Services Inc.  1800 Larimer Street, Suite _____  Denver, CO 80202</p> <p><i>with a cc to:</i></p> <p>_____</p> <p>Purchased Power Analyst  Xcel Energy Services Inc.  1800 Larimer Street, Suite 1000  Denver, CO 80202</p>	<p><b>Notices:</b></p> <p>_____</p> <p>_____</p> <p>_____</p> <p><i>with a cc to:</i></p> <p>_____</p> <p>_____</p> <p>_____</p>
<p><b>Operating Committee Representative:</b></p> <p>_____</p> <p>Renewable Purchased Power Manager  Xcel Energy Services Inc.  1800 Larimer Street, Suite 1000  Denver, CO 80202</p> <p><b>Alternate:</b></p> <p>_____</p> <p>Purchased Power Analyst  Xcel Energy Services Inc.  1800 Larimer Street, Suite 1000  Denver, CO 80202</p>	<p><b>Operating Committee Representative:</b></p> <p>_____</p> <p>_____</p> <p>_____</p> <p><b>Alternate:</b></p> <p>_____</p> <p>_____</p> <p>_____</p>
<p><b>Real-Time Contact Information</b></p> <p><u>EMCC</u> (24 hour coverage):  Phone: 303-571-6280  E-mail: _____@xcelenergy.com</p> <p><u>Transmission Ops:</u>  Phone: 303-571-6490  E-mail: _____@xcelenergy.com</p>	<p><b>Real-Time Contact Information</b></p> <p><u>[Operations Command Center]</u>  (24 hour coverage):  Phone: _____  E-mail: _____</p>

**EXHIBIT E  
INSURANCE COVERAGE**

Type of Insurance	Minimum Limits of Coverage
-------------------	----------------------------

Commercial General Liability (CGL) and commercial umbrella	\$11,000,000 combined single limit each occurrence and the aggregate, where applicable. If CGL insurance contains a general aggregate limit, it shall apply separately to the Facility.
--	---

CGL insurance shall be written on ISO occurrence form CG 00 01 01 96 (or a substitute form providing equivalent coverage) and shall cover liability arising from premises, operations, independent contractors, products/completed operations, contracts, property damage, personal injury and advertising injury, and liability assumed under an insured contract (including the tort liability of another assumed in a business contract), all with limits as specified above. CGL insurance shall include ISO endorsement CG 24 17 (or an equivalent endorsement) which modifies the definition of "Insured contract" to eliminate the exclusion of easement or license agreements in connection with construction or demolition operations on or within 50 feet of a railroad. There shall be no endorsement or modification of the CGL insurance limiting the scope of coverage for liability arising from explosion, collapse, or underground property damage.

Company shall be included as an insured under the CGL policy, using ISO additional insured endorsement CG 20 10 (or a substitute providing equivalent coverage), and under the commercial umbrella insurance. The commercial umbrella insurance shall provide coverage over the top of the CGL insurance, the Business Automobile Liability insurance, and the Employers Liability insurance. The CGL and commercial umbrella insurance to be obtained by or on behalf of Seller shall be endorsed as follows:

Such insurance as afforded by this policy for the benefit of Company shall be primary as respects any claims, losses, damages, expenses, or liabilities arising out of this PPA, and insured hereunder, and any insurance carried by Company shall be excess of and noncontributing with insurance afforded by this policy.

Business Automobile Liability	\$2,000,000 combined single limit (each accident), including all Owned, Non-Owned, Hired and Leased Autos.
-------------------------------	--

Business Automobile Liability insurance shall be written on ISO form CA 00 01, CA 00 05, CA 00 12, CA 00 20, or a substitute form providing equivalent liability coverage. If necessary, the policy shall be endorsed to provide contractual liability coverage equivalent to that provided in the 1990 and later editions of CA 00 01.

Workers Compensation	Statutory Requirements. Seller may comply with these requirements through the use of a qualified self-insurance plan.
----------------------	---

[Exhibit E - continued]

Type of Insurance	Minimum Limits of Coverage
-------------------	----------------------------

Employers Liability	\$2,000,000 each accident for bodily injury by accident, or \$2,000,000 each employee for bodily injury by disease.
---------------------	---

Builder's Risk	Replacement value of the Facility.
----------------	------------------------------------

Builder's Risk insurance, or an installation floater, shall include coverage for earthquake and flood, collapse, faulty workmanship, materials and design, testing of machinery or equipment, freezing or changes in temperature, debris removal, and partial occupancy.

Environmental Impairment Liability	\$5,000,000 each occurrence.
------------------------------------	------------------------------

All-Risk Property insurance covering physical loss or damage to the Facility	Full replacement value of the Facility. A deductible may be carried which deductible shall be the absolute responsibility of Seller.
--	--

All-Risk Property insurance shall include: (i) coverage for fire, flood, wind and storm, tornado and earthquake with respect to facilities similar in construction, location and occupancy to the Facility, with sublimits of no less than \$10,000,000 each for flood and earthquake; and (ii) Boiler and Machinery insurance covering all objects customarily subject to such insurance, including boilers and turbines, in an amount equal to their full replacement value.

Business Interruption insurance	Amount required to cover Seller's continuing or increased expenses, resulting from full interruption, for a period of 12 calendar months.
---------------------------------	---

Business Interruption insurance shall cover loss of revenues or the increased expense to resume operations attributable to the Facility by reason of total or partial suspension or delay of, or interruption in, the operation of the Facility as a result of an insured peril covered under Property insurance as set forth above, to the extent available on Commercially Reasonable terms as determined by Company, subject to a Commercially Reasonable deductible that shall be the responsibility of Seller. Notwithstanding any other provision of this PPA, Seller shall not be required to have Business Interruption insurance until the Commercial Operation Date.

**EXHIBIT F**  
**SELLER'S NEEDED PERMITS**

Bid Specific

**EXHIBIT G**  
**FORM OF LETTER OF CREDIT**

[LETTERHEAD OF ISSUING BANK]

Irrevocable Standby Letter of Credit  
No: \_\_\_\_\_

Date of Issuance: \_\_\_\_\_

Beneficiary: Southwestern Public  
Service Company

Initial Expiration Date: [Must be at least  
one year after date of issuance]

Applicant:

As the Issuing Bank ("Issuer"), we, [Name of Issuing Bank], hereby establish this irrevocable Standby Letter of Credit No. \_\_\_\_\_ (this "Letter of Credit") in favor of the above-named beneficiary ("Beneficiary") for the account of the above-named applicant ("Applicant") in the amount of US\$ \_\_\_\_\_ (\_\_\_\_\_ Million U.S. Dollars).

Beneficiary may draw all or any portion of this Letter of Credit at any time and from time to time, and Issuer will make funds immediately available to Beneficiary upon presentation of Beneficiary's draft(s) at sight in substantially the form attached hereto as Exhibit "A" ("Sight Draft"), drawn on Issuer and accompanied by this Letter of Credit. All Sight Drafts must be signed on behalf of Beneficiary, and the signator must indicate his or her title or other official capacity. No other documents will be required to be presented. Issuer will effect payment under this Letter of Credit within twenty-four (24) hours after presentment of any Sight Draft. Payment shall be made in U.S. Dollars with Issuer's own funds in immediately available funds.

Issuer will honor any Sight Draft presented in substantial compliance with the terms of this Letter of Credit at the Issuer's letterhead office, the office located at \_\_\_\_\_ or any other full service office of the Issuer on or before the above-stated expiration date, as such expiration date may be extended hereunder. Partial and multiple draws and presentations are permitted on any number of occasions. Following any partial draw, Issuer will endorse this Letter of Credit and return the original to Beneficiary.

This Letter of Credit is issued pursuant to the provisions of that certain Wind Energy Purchase Agreement between Beneficiary and Applicant dated as of \_\_\_\_\_, 20\_\_ (as the same may have been or may be amended from time to time, the "PPA"). Notwithstanding any reference in this Letter of Credit to the PPA or any other documents, instruments or agreements, or references in the PPA or any other documents, instruments or agreements to this Letter of Credit, this Letter of Credit contains the entire agreement between Beneficiary and Issuer relating to the obligations of Issuer hereunder.

This Letter of Credit will be automatically extended each year without amendment for a period of one (1) year from the expiration date hereof, as extended, unless at least

thirty (30) days prior to the expiration date, Issuer notifies Beneficiary by registered or certified mail that it elects not to extend this Letter of Credit for such additional period. Notice of non-extension will be given by Issuer to Beneficiary at Beneficiary's address set forth herein or at such other address as Beneficiary may designate to Issuer in writing at Issuer's letterhead address.

This Letter of Credit is freely transferable by Beneficiary in whole or in part, and the number of transfers is unlimited. Issuer shall effect any transfers immediately upon presentation to Issuer of this Letter of Credit and a completed written transfer request substantially in the form attached hereto as Exhibit "B." Such transfer will be effected at no cost to Beneficiary. Any transfer fees assessed by Issuer will be payable solely by Applicant, and the payment of any transfer fees will not be a condition to the validity or effectiveness of the transfer of this Letter of Credit.

Issuer waives any rights it may have, at law or otherwise, to subrogate to any claims which Beneficiary may have against Applicant or Applicant may have against Beneficiary.

This Letter of Credit is subject to the uniform customs and practice for documentary credits (2007 Revision), International Chamber of Commerce publication No. 600 (the "UCP"), except to the extent that the terms hereof are inconsistent with the provisions of the UCP, including but not limited to Articles 14(b) and 36 of the UCP, in which case the terms of this Letter of Credit shall govern. With respect to Article 14(b) of the UCP, Issuer shall have a reasonable amount of time, not to exceed three (3) banking days following the date of Issuer's receipt of documents from Beneficiary (to the extent required herein), to examine the documents and determine whether to take up or refuse the documents and to inform Beneficiary accordingly.

In the event of an act of God, riot, civil commotion, insurrection, war or any other cause beyond Issuer's control that interrupts Issuer's business and causes the place for presentation of this Letter of Credit to be closed for business on the last day for presentation, the expiry date of this Letter of Credit will be automatically extended without amendment to a date thirty (30) calendar days after the place for presentation reopens for business.

ISSUER:

By: \_\_\_\_\_  
Authorized Signature

**EXHIBIT "A"**  
TO LETTER OF CREDIT

**SIGHT DRAFT**

Draft Number \_\_\_\_\_  
\$ \_\_\_\_\_

At sight, pay to the order of [Name of Beneficiary to be inserted], the amount of USD \$ \_\_\_\_\_ ( \_\_\_\_\_ and 00/100ths U.S. Dollars).

Value received and charged to the account of: [Name of Issuer and address].  
Drawn under [Name of Issuer to be inserted] Standby Letter of Credit No.  
\_\_\_\_\_.

Dated: \_\_\_\_\_

Southwestern Public Service Company

By: \_\_\_\_\_  
[name and title]

Account: [Applicant to be inserted]



**EXHIBIT "B"**  
TO LETTER OF CREDIT

**FORM OF TRANSFER REQUEST**

Irrevocable Standby Letter of Credit No. \_\_\_\_\_

Current Beneficiary:

Applicant:

\_\_\_\_\_  
\_\_\_\_\_  
\_\_\_\_\_

\_\_\_\_\_  
\_\_\_\_\_  
\_\_\_\_\_

To: [Name of Issuer] ("Issuer")

The undersigned, as the current "Beneficiary" of the above-referenced Letter of Credit, hereby requests that you reissue the Letter of Credit in favor of the transferee named below [insert transferee name and address below]:

\_\_\_\_\_  
\_\_\_\_\_  
\_\_\_\_\_

From and after the date this transfer request is delivered to Issuer, the transferee shall be the "Beneficiary" under the Letter of Credit for all purposes and shall be entitled to exercise and enjoy all of the rights, privileges and benefits thereof.

Dated: \_\_\_\_\_

Southwestern Public Service Company

By: \_\_\_\_\_

Name: \_\_\_\_\_

Title: \_\_\_\_\_

[Notary Acknowledgement]

To be signed by a person purporting to be an authorized representative of Beneficiary and indicating his or her title or other official capacity, and acknowledged by a notary public.

**EXHIBIT H**  
**FORM OF GUARANTY**

**GUARANTY**

This Guaranty is executed and delivered as of this \_\_\_\_ day of \_\_\_\_\_, 20\_\_ by \_\_\_\_\_, a \_\_\_\_\_ [corporation] ("Guarantor"), in favor of Southwestern Public Service Company ("Company"), in connection with the performance by \_\_\_\_\_, a \_\_\_\_\_ [limited liability company] ("Seller") of a Wind Energy Purchase Agreement dated \_\_\_\_\_, 20\_\_ between Seller and Company (the "PPA").

- RECITALS -

A. Seller owns and operates a wind power electric generation facility having total nameplate capacity of approximately \_\_\_\_ MW located in \_\_\_\_\_ County, \_\_\_\_\_ (the "Facility").

B. Seller and Company have entered into the PPA for the purchase and sale of capacity and electrical energy from the Facility on the terms and conditions set forth therein.

C. Seller is controlled by Guarantor. Guarantor expects to derive substantial benefits from the performance of the PPA by Seller and Company. To induce Company to enter into and continue the PPA and to consummate the purchase and sale of electrical energy contemplated by the PPA, Guarantor has agreed to guarantee the obligations of Seller as provided in this Guaranty.

NOW, THEREFORE, in consideration of the foregoing, Guarantor agrees as follows:

- AGREEMENT -

1. Guaranty. Subject to the provisions of this Guaranty, Guarantor hereby absolutely, irrevocably, unconditionally, and fully guarantees to Company the due, prompt, and complete observance, performance, and discharge of each and every payment obligation of Seller under the PPA, whether incurred before or after the date of delivery of this Guaranty (the "Obligations"). This is a guaranty of payment, not of collection, and as such, Company shall not be required to institute, pursue, or exhaust any remedies against Seller before instituting suit, obtaining judgment, and executing thereon against Guarantor under this Guaranty. This Guaranty shall survive termination of the PPA to the extent necessary to enforce and complete the rights, duties and obligations of Company and Seller thereunder.

2. Maximum Liability. Notwithstanding anything herein to the contrary, Guarantor's maximum liability under this Guaranty shall be limited to \_\_\_\_\_ dollars (US\$\_\_\_\_\_) plus costs of collection under Section 10 below.

3. Rights of Company. Guarantor hereby grants to Company, in Company's discretion and without the need to notify or obtain any consent from Guarantor, and without termination, impairment, or any other effect upon Guarantor's duties hereunder, the power and authority from time to time:

(a) to renew, compromise, extend, accelerate, or otherwise change, substitute, supersede, or terminate the terms of performance of any of the Obligations, in each case in accordance with the PPA;

(b) to grant any indulgences, forbearances, and waivers, on one or more occasions, for any length of time, with respect to Seller's performance of any of the Obligations; and

(c) to accept collateral, further guaranties, and/or other security for the Obligations, and, if so accepted, then to impair, exhaust, exchange, enforce, waive, or release any such security.

4. Performance. If any of the Obligations are not performed according to the tenor thereof, and any applicable notice and cure period provided by the PPA has expired ("Default"), Guarantor shall immediately upon receipt of written demand by Company (a) perform or cause Seller to perform the Obligation in Default, and (b) pay, reimburse, and indemnify Company against any liabilities, damages, and related costs (including attorneys' fees) incurred by Company as a result thereof, all in such manner and at such times as Company may reasonably direct.

5. Satisfaction. Satisfaction by Guarantor of any duty hereunder incident to a particular Default or the occurrence of any other Default shall not discharge Guarantor except with respect to the Default satisfied, it being the intent of Guarantor that this Guaranty be continuing until such time as all of the Obligations have irrevocably been discharged in full, at which time this Guaranty shall automatically terminate. If at any time the performance of any Obligation by Seller or Guarantor is rescinded or voided under the federal Bankruptcy Code or otherwise, then Guarantor's duties hereunder shall continue and be deemed to have been automatically reinstated, restored, and continued with respect to that Obligation, as though the performance of that Obligation had never occurred, regardless or whether this Guaranty otherwise had terminated or would have been terminated following or as a result of that performance.

6. Notice of Acceptance. Guarantor waives and acknowledges notice of acceptance of this Guaranty by Company.

7. Waivers by Guarantor. Guarantor hereby waives and agrees not to assert or take advantage of:

(a) all set-offs, counterclaims, and, subject to Section 4 above, all presentments, demands for performance, notices of non-performance, protests, and notices of every kind that may be required by Applicable Laws;

(b) any right to require Company to proceed against Seller or any other person, or to require Company first to exhaust any remedies against Seller or any other person, before proceeding against Guarantor hereunder;

(c) any defense based upon an election of remedies by Company;

(d) any duty of Company to protect or not impair any security for the Obligations;

(e) the benefit of any laws limiting the liability of a surety;

(f) any duty of Company to disclose to Guarantor any facts concerning Seller, the PPA or the Facility, or any other circumstances, that would or allegedly would increase the risk to Guarantor under this Guaranty, whether now known or hereafter learned by Company, it being understood that Guarantor is capable of and assumes the responsibility for being and remaining informed as to all such facts and circumstances; and

(g) until all Obligations in Default have been fully paid and/or performed, any rights of subrogation, contribution, reimbursement, indemnification, or other rights of payment or recovery for any payment or performance by it hereunder. For the avoidance of doubt, if any amount is paid to Guarantor in violation of this provision, such amount shall be held by Guarantor for the benefit of, and promptly paid to, Company.

8. Cumulative Remedies. The rights and remedies of Company hereunder shall be cumulative and not alternative to any other rights, powers, and remedies that Company may have at law, in equity, or under the PPA. The obligations of Guarantor hereunder are independent of those of Seller and shall survive unaffected by the bankruptcy of Seller. Company need not join Seller in any action against Guarantor to preserve its rights set forth herein.

9. Representations and Warranties. Guarantor represents and warrants to Company as follows:

(a) Guarantor is a corporation, duly organized, validly existing, and in good standing under the laws of the state of its incorporation. Seller is a direct or indirect wholly-owned subsidiary of Guarantor. Guarantor has all necessary corporate power and authority to execute and deliver this Guaranty and to perform its obligations hereunder.

(b) The execution, delivery and performance of this Guaranty has been duly and validly authorized by all corporate proceedings of Guarantor and is not in violation of any law, judgment of court or government agency. This Guaranty has been duly and validly executed and delivered by Guarantor and constitutes a legal, valid and binding obligation of Guarantor, enforceable against Guarantor in accordance with its terms.

10. Collection Costs. Guarantor shall pay to Company, upon demand, and in addition to the maximum liability set forth in Section 3 hereof, all reasonable attorneys' fees and other expenses which Company may expend or incur in enforcing the Obligations against Seller and/or enforcing this Guaranty against Guarantor, whether or not suit is filed, including, without limitation, all attorneys' fees, and other expenses incurred by Company in connection with any insolvency, bankruptcy, reorganization, arrangement, or other similar proceedings involving Seller that in any way affect the exercise by Company of its rights and remedies hereunder.

11. Severability. Should any one or more provisions of this Guaranty be determined to be illegal or unenforceable, all other provisions nevertheless shall be effective.

12. Waiver or Amendment. No provision of this Guaranty or right of Company hereunder can be waived, nor can Guarantor be released from Guarantor's duties hereunder, except by a writing duly executed by Company. This Guaranty may not be modified, amended, revised, revoked, terminated, changed, or varied in any way whatsoever except by the express terms of a writing duly executed by Company.

13. Successors and Assigns. This Guaranty shall inure to the benefit of and bind the successors and assigns of Company and Guarantor.

14. Governing Law. This Guaranty shall be governed by and construed in accordance with the law of the State of *[insert home state of Company]* without regard to the principles of conflicts of law thereof. Venue for any dispute hereunder shall be as set forth in Section 13.5 of the PPA.

15. Notices. All notices, requests, claims, demands, and other communications hereunder shall be in writing and shall be given (and shall be deemed to have been duly given upon receipt) by delivery in the manner contemplated by the PPA, addressed as follows:

(a) if to Company: as provided in the PPA

(b) if to Guarantor: \_\_\_\_\_

\_\_\_\_\_  
Attn:

with a copy to: \_\_\_\_\_

\_\_\_\_\_  
Attn:

or to such other address (es) as the person to whom notice is given may have previously furnished to the others in writing in the manner set forth above.



**EXHIBIT I**

**AGC PROTOCOLS; DATA COLLECTION; TECHNICAL SPECIFICATIONS**

**AGC**

**1. AGC Communications between Company and Seller**

Company will receive and send AGC Set-Point and related data over an analog or digital line. The data points covered under this PPA, as described below, may overlap data requirements for the Transmission Authority or Company’s applicable forecasting group.

**2. AGC Data Points to be sent from Seller to Company via SCADA**

The following data points will be transmitted via SCADA from Seller to Company and represent Facility level data:

<u>Description</u>	<u>Units</u>
AGC Set-Point (echo)	MW
Power demand	MW
Actual power	MW
Park Potential	MW
Actual reactive power	Mvars
Average Voltage	kV
Number of turbines online and running	Integer
AGC Status	Remote/Local

**3. Response times and limitations of Facility in regards to AGC**

The following protocols outline the expectations for responding to the AGC Set-Point. Except in the case of the Frequency of Changes, these protocols will be generally bound by the manufacturers’ specifications for the equipment that Seller has chosen for the Facility.

a. Allowable Variances in Excess of AGC Set-Point. Once the Facility has reached the AGC Set-Point, there may be variances in excess of such set-point up to 2% on average as measured during a 10-minute period. This is due to changing wind conditions vs. the manufacturer’s specifications for responding to those new conditions.

b. Frequency of Changes. Company may send a new AGC Set-Point to the Facility as frequently as the Wind Turbine manufacturer specifications allow.

c. Range of AGC Set-Point. The range of set point values can be between 0% and 100% of Park Potential.

#### **4. Backup Communications**

In the event of an AGC failure, Company and Seller shall communicate via telephone in order to correct the failure.

### **DATA COLLECTION**

#### **1. Data**

At least two months prior to the Commercial Operation Date, Seller will deliver to Company a report showing (i) manufacturer, model, and year of all Wind Turbines and meteorological instrumentation and (ii) the latitude, longitude and hub height at every Wind Turbine and meteorological tower.

Beginning upon COD, Seller shall transmit and provide to Company the real-time data set forth below, refreshed in approximately four-ten (4-10) second intervals with regard to its generation of Renewable Energy at the Facility:

a. Five data points from each Wind Turbine:

1. Turbine generation (kW)
2. Wind Speed (meters per second - mps)
3. Turbine Availability
4. Wind Direction (in degrees relative to true north)
5. Temperature (Celsius)

b. Five data points from each Meteorological Tower:

1. Wind Speed\*\* (mps)
2. Wind Direction\*\* (degrees relative to true north)
3. Temperature (Celsius)
4. Pressure (mb)
5. Air Density (kg/m<sup>3</sup>)

\*\* = at all metered heights.

c. In addition to the other requirements for data collection, Seller shall install, maintain and operate at least one meteorological tower that is installed at hub height and is placed upstream of the prevailing wind path. The data stream from this meteorological tower to the Company's PI System must be reliable during periods of transmission-related curtailments and must include battery back-up at the meteorological tower and a local source of electricity to power the PI System and interconnectivity between the Facility and Company during transmission outages.

d. Seller shall provide a map and key for each Wind Turbine sufficient to allow Company to correlate the data received through the PI System to each individual Wind Turbine.



## 2. Forecasting Requirements

a. Not later than 5:00 am on each Day, Seller shall post an availability and production forecast for the Facility through 11:00 pm on the following Day. The forecast shall be submitted through an availability forecast system specified by Company to Seller. Prior to the Commercial Operation Date, Company shall provide Seller with information necessary for Seller to access the chosen availability forecast system.

b. If any events or circumstances reduce the forecasted availability of the Facility by 5 MW or more, such reduction shall be (1) communicated to the real-time operator via telephone with (2) immediate update to the availability forecast in the availability forecast system. For example:

i. A disturbance at a 100.5 MW (67 x 1.5 MW wind turbines) wind plant causes 26 wind turbines (39 MW) to become unavailable. Only two turbines were planned to be down for maintenance (3 MW). The expected reduction in the available capacity is 39 MW; exceeding the 5 MW requirement. A phone call to real-time operations with immediate update of the availability forecast is required. At the time of the outage, the estimated expected duration was thought to be six hours. Three hours into the outage, it became known that the 26 turbines would be available in an hour. A phone call notifying real-time of the change in availability is required with a coincident update in the availability forecast system.

ii. A disturbance at a 10 MW (8 x 1.25 MW turbines) wind plant forces 4 turbines (5 MW) off-line. Because the disturbance equals 5 MW, a phone call to real-time operations with immediate update of the availability forecast is required. If the disturbance had only affected 3 turbines (3.75MW), then no immediate action would be necessary.

iii. A 20 MW (20 x 1 MW turbines) wind plant is off-line for transmission maintenance. The maintenance work is completed 2 hours ahead of the projected completion. Because the change is greater than 10 MW, prior to coming on-line, a phone call is required coincident with an update to the availability forecast system to indicate the new availability.

## **SURFACE WEATHER SYSTEM TECHNICAL SPECIFICATIONS**

The Surface Weather System shall satisfy the following technical specifications, all at Seller's cost:

### Vaisala Hydromet System AWS301 (Quantity: 1)

- Data Collection and Processing System (DCP)
- AWS base unit w/ QML201C logger and BOX652 enclosure for DCP with Installation Frame and Radiation Shield
- Basic 24VDC main power supply
- Extra 24VDC main power supply

- Interface for 2x12V/26Ah Internal Batteries
- BAR0-1QML press. sensor Class A calibration
- PWD22 heated 3.85m cable + mounting
- QMD202 display and keypad inside enclosure
- Standard AWS310 configuration for data collection unit with non-metric (US) units
- Wall/H Frame installation kit
- Rubber enclosure flanges Option
- TERMBOX-1212 option
- MCC301 Observation Software (Standard)
- RS-232 Maintenance Cable for DCP
- Removable CF Card 2 GB for DCP with Industrial Temperature Range (2 pcs)
- RS-485 (2-w) Interface with DCP with Connector, Wiring and Surge Protector Using COM 1
- DSI486 Dual RS-485 Module for DCP (2 x RS-485 (2-w) + 1 x SDI-12) DSI486 Dual RS-485 Module for DCP (2 x RS-485 (2-w) + 1 x SDI-12)
- Sensor Interface for DCP with Connector and Wiring to one (1) HMP155 Air Temperature and Relative Humidity Sensor, Heated RH, via RS-485 (2-w) using mod 2 DSI486 port 2
- Sensor Interface for DCP Surge Protection, Connectors and Wiring to one (1) WMT702 Ultrasonic Wind Sensor (Heated) via RS-485 (2-w). ADC40V60 req. using mod 1 DSI486 port 2
- Sensor Interface for DCP Surge Protection, Connectors and Wiring to one (1) WMT702 Ultrasonic Wind Sensor (Heated) via RS-485 (2-w). ADC40V60 req. using mod 2 DSI486 port 2

Backup Batteries (Quantity: 1)

- Battery 12V 26Ah

LCD Display & Keyboard Unit (Quantity: 1)

- Display/Keyboard for MAWS Enclosure Door

Hub Height Level Sensors/ 1 RHAT & 2 WIND - Air Temp, RH and Dew Point

- 1 x HMP155 Humidity and Temperature Probe, Heated RH (separate T and RH via RS485)
- 2 x WMT702 transd.+arms heat 10m cable + mast mount
- 1 x Radiation Shield for Humidity and Temperature Probe with Mounting Kit (installed on pole mast 60-100 mm)
- Cable, Extension M112 8N Female to Male, 3M (8-pin F-M connectors)
- Cable to connect sensor to WSP150, cut to length, plus connection from WSP150 to Termination Box
- Surge Protector — For Data and Power Wiring

- 2 x WMT702 transducers+ arms heated 10m cable + mast mount
  - Stainless Steel Enclosure
  - Heated transducers and arms
  - RS-485/RS-422/RS-232
  - Metric Setup
  - No Power Supply or Cable
  - No Mounting Adaptor
  - Basic Configuration Work
  - Manual
- Mounting Adaptor 30 mm
- RS-485 and Power Cable for MAWS/WMT702, 10M Cable to connect sensor to WSP150, cut to length, plus connection from WSP150 to Termination Box
- Surge Protector — For Data and Power Wiring
- 8' Retractable Boom w/Sensor Mount (Quantity: 2)
- 12 pair data cable, 22 gauge, open leads, Hub Height
- Termination Box with Mounting Kit (Hub Height), mounted at Hub Height Level
- 5 Conductor Power Cables, 16 gauge, open leads, Hub Height
- OPTIONAL Ice Condition Monitoring : PWD22 heated 3.85m cable + mounting

Extended Warranty

- Extended Warranty for up to four (4) years

Additionally, the installation of the Vaisala Surface Weather System shall require the following services: Configuration Work, Site Survey, Instrument Installation Day on Site-Vaisala, and Project Engineering/Management Work.

\* \* \* \* \*

**EXHIBIT J**

**ENERGY PAYMENT RATE; COMMITTED ENERGY**

*This entire Exhibit shall be deemed Confidential Information subject to Section 20.18.*

Commercial Operation Year	Energy Payment Rate (\$/MWh)	Committed Energy (MWh)	Commercial Operation Year	Energy Payment Rate (\$/MWh)	Committed Energy (MWh)
1	\$ _____	_____		\$ _____	_____
2	\$ _____	_____		\$ _____	_____
3	\$ _____	_____		\$ _____	_____
4	\$ _____	_____		\$ _____	_____
5	\$ _____	_____		\$ _____	_____
6	\$ _____	_____		\$ _____	_____
7	\$ _____	_____		\$ _____	_____
8	\$ _____	_____		\$ _____	_____
9	\$ _____	_____		\$ _____	_____
10	\$ _____	_____		\$ _____	_____
	\$ _____	_____		\$ _____	_____

## EXHIBIT K

### LENDER CONSENT PROVISIONS

In the event Seller collaterally assigns its rights hereunder to a Facility Lender as security, any related Lender Consent will contain provisions substantially as follows:

1. Seller and Company will neither modify nor terminate the PPA in any material respect, without the prior written consent of the Facility Lender.
2. The Facility Lender shall have the right, but no obligation, to do any act required to be performed by Seller under the PPA, and any such act performed by the Facility Lender shall be as effective to prevent or cure a default as if done by Seller itself.
3. If Company becomes entitled to terminate the PPA due to an Event of Default by Seller, Company shall not terminate the PPA unless it has first given notice of such Event of Default to the Facility Lender and has given the Facility Lender the same cure period afforded to Seller under Article 12 of the PPA, plus an additional 30 Days beyond Seller's cure period to cure such Event of Default; *provided, however*, that if the Facility Lender requires possession of the Facility in order to cure the Event of Default, and if the Facility Lender diligently seeks possession, the Facility Lender's additional 30-Day cure period shall not begin until foreclosure is completed, a receiver is appointed, any bankruptcy stay is removed, or possession is otherwise obtained by or on behalf of the Facility Lender.
4. The Facility Lender shall provide to Company a copy of any notices of default and/or intent to exercise remedies delivered to Seller under the Financing Documents.
5. Upon any foreclosure, deed-in-lieu or other exercise of the rights and remedies of the Facility Lender that results in a successor owner or operator of the Facility, the Facility Lender shall require and cause the successor (i) to assume all of Seller's prospective obligations under the PPA, (ii) to cure any then-existing defaults by Seller that are capable of cure by performance or the payment of money damages, (iii) to have substantial experience in the operation of power generation facilities akin to the Facility, either directly, through its affiliates or through an operator acceptable to Company, and (iv) to enjoy (together with its parents and affiliates) an Investment Grade Credit Rating or other creditworthiness satisfactory to Company. Except for the foregoing, the Facility Lender shall not be obligated to perform or be liable for any obligation of Seller under the PPA.
6. Upon any rejection or other termination of the PPA in connection with any bankruptcy or insolvency of Seller, the Facility Lender (or its successor) and Company shall enter into a new power purchase agreement on the same terms and conditions as the PPA and for the period that would have been remaining under the PPA but for such termination.

\* \* \* \* \*

## EXHIBIT L PSA PROVISIONS

Any PSA executed to implement exercise of Company's [Option or] ROFO rights will include provisions substantially as follows:

1. The PSA shall close on such Business Day as may be specified by Company, not more than 180 Days following execution of the PSA (or such longer period as may be required for the State Regulatory Agency to act thereon).

2. Seller shall operate the Facility, and both Parties shall perform the PPA, in the ordinary course of business pending closing of the PSA.

3. Seller shall convey the Facility to Company via special warranty deed, free and clear of all mortgages, deeds of trust, UCC-1s, and other liens materially adverse to Company's ownership and operation thereof.

4. All revenues and expenses of the Facility shall be prorated as of the date of closing.

5. Seller shall provide customary comprehensive representations, warranties and indemnities to Company regarding its legal right to execute and perform the PSA, and regarding title, physical condition, vendors, employees, operations, finances, contracts, maintenance and other relevant matters pertaining to the Facility, unqualified by its knowledge but subject to such factual exceptions as Seller may disclose. Absent fraud, Seller's liability for breach of such reps and warranties shall not exceed 100% of the purchase price. Seller's post-closing obligations shall be secured by a suitable combination of hold-back escrow, letter of credit and/or guaranty from a creditworthy affiliate.

6. Company shall provide customary representations and warranties to Seller regarding its capacity and legal right to execute and perform the PSA, unqualified by its knowledge.

7. Company shall assume all material contracts of Seller related to the Facility that are reviewed and approved by Company (such approval not to be unreasonably withheld) during the due diligence period.

8. Company's obligation to close shall be conditioned upon (i) approval by the State Regulatory Agency, (ii) counterparty consent under all material contracts requiring such consent, (iii) receipt by Company of all Permits needed to own and operate the Facility, and (iv) no material casualty or condemnation of the Facility prior to closing.

9. Company shall have the right of specific performance, without the need to post bond or prove irreparable harm from Seller's failure to close. Venue for any dispute under the PSA shall be the State District Court for the County in which the Facility is located.

10. Such other terms as may then be standard in the market.

\* \* \* \* \*

## EXHIBIT M

### AVAILABILITY GUARANTY CALCULATION

*[insert definitions and calculations of “Availability” and “Availability Factor” from the Guaranty section of Seller’s Turbine Supply Agmt or O&M Agmt – Seller to provide – example may be included]*