



GA34-0054-2

File No. S/5250/5280, S/34-03

IBM 5225 Printer
Models 1, 2, 3, and 4
Operator's Guide



GA34-0054-2

File No. S/5250/5280, S/34-03

IBM 5225 Printer
Models 1, 2, 3, and 4
Operator's Guide

Federal Communications Commission (FCC) Notice

Warning: This equipment generates, uses, and can radiate radio frequency energy and if not installed and used in accordance with the instruction manual, may cause interference to radio communications. It has been tested and found to comply with the limits for a Class A computing device pursuant to Subpart J of Part 15 of FCC Rules, which are designed to provide reasonable protection against such interference when operated in a commercial environment. Operation of this equipment in a residential area is likely to cause interference in which case the user at his own expense will be required to take whatever measures may be required to correct the interference.

Third Edition (June 1982)

This is a major revision of and obsoletes, GA34-0054-1. Because the changes are significant, this manual should be reviewed in its entirety.

Use this publication only for the purpose stated in the Preface.

Changes are periodically made to the information herein; any such changes will be reported in subsequent revisions or Technical Newsletters.

It is possible that this material may contain reference to, or information about, IBM products (machines and programs), programming, or services that are not announced in your country. Such references or information must not be construed to mean that IBM intends to announce such IBM products, programming, or services in your country.

Publications are not stocked at the address given below. Requests for copies of IBM publications should be made to your IBM representative or the IBM branch office serving your locality.

This publication could contain technical inaccuracies or typographical errors. A form for readers' comments is provided at the back of this publication. If the form has been removed, address your comments to IBM Corporation, Information Development, Department 27T, P. O. Box 1328, Boca Raton, Florida 33432. IBM may use or distribute any of the information you supply in any way it believes appropriate without incurring any obligation whatever. You may, of course, continue to use the information you supply.

Preface

This publication is a guide for operating the IBM 5225 Printer Models 1, 2, 3, and 4. Although this publication is for all operators, it is intended especially for the inexperienced operator of computer equipment. The operating procedures are presented in an easy-to-follow format. A procedure for solving printer problems is included.

The information is presented in six chapters:

- Chapter 1, "Introduction," introduces the operator to the operation of the printer, and includes some suggestions for caring for the printer.
- Chapter 2, "Printer Controls," identifies the operator's panel, the Power switch, the forms controls, the customer access panel, and describes the purpose of each.
- Chapter 3, "Loading and Unloading Forms," describes how to load, adjust, and unload forms (paper).
- Chapter 4, "Replacing the Ribbon and Ribbon Shield," describes how to change the ribbon and the ribbon shield.
- Chapter 5, "Operating Procedures," explains how to prepare the printer for operation, operate the printer, and recognize its status.
- Chapter 6, "Solving Printer Problems," gives a problem recovery procedure, and includes a checklist of items to be recorded if service becomes necessary.

Related Publications

Additional information about using this printer can be found in:

- *Forms Design Reference Guide for Printers*, GA24-3488
- *IBM 5225 Printer Models 1, 2, 3, and 4, Setup Instructions*, GA34-0085
- Publications for the computer system (host) to which the printer is connected

Requests for copies of these publications should be made to your IBM representative, or the IBM branch office serving your locality.

Contents

Chapter 1 Introduction	1-1
Chapter 2 Printer Controls	2-1
Chapter 3 Loading and Unloading Forms	3-1
Chapter 4 Replacing the Ribbon and Ribbon Shield	4-1
Chapter 5 Operating Procedures	5-1
Chapter 6 Solving Printer Problems	6-1

Chapter 1. Introduction

Contents

Printing Specifications	1-2
The Computer System	1-4
Your Job as Operator	1-5
Loading and Unloading Forms	1-5
Replacing the Ribbon and Ribbon Shield	1-5
Operating the Printer	1-5
Solving Printer Problems	1-5
Caring for The Printer	1-6

This chapter contains:

- A summary of printing specifications
- An explanation of your printer's relationship to a computer system
- Information about what you will be doing as an operator
- Recommendations for caring for your printer

Printing Specifications

Character density: 10 or 15 characters per inch
 Line density: 6 or 8 lines per inch

ORDER ANTICIPATION REQUIREMENTS REPORT													
ORD QTY	PART NUMBER	QTY	DEMAND	BUY IN LOTS	USE CL	FAC CL	WGT AVG	SALES CUR MO	STOCK OUTS	QTY ON ORD	QTY ON HND	QTY B.O.	SELL PRICE
X 237		5	30		A	B	9	4	0	0	25		.3500
X 250		92	527		A	A	186	52	0	100	335		.3500
X 262		64	149		A	C	34	2	0	0	85		.5700
X 275	*	40	80		A	A	24	68	21	50	1 *	11	.7400
X 300		18	136		A	A	44	6	0	20	98		.7800
X 325		9	9		B	B	3	1	1	10	0		1.4200
X 400		5	45		A	A	17	10	8	10	30 *		1.0800
XD 187		36	222		A	A	71	37	0	0	186		.4400
XD 200	*	324	711		A	A	262	389	26	400	77		.4400
XD 212	*	40	144		A	A	45	46	0	0	104		.5200
XD 225	*	194	268		A	A	260	340	49	550	24 *		.5200
XD 250		125	528		A	A	160	20	150	253 *			.5200
8275 A													
2726		1	1		N	N	1	0	0	0	0		13.4500
2727		5	17		N	N	8	6	0	1	6		13.4500
2727		1	8		N	N	4	2	0	0	7		13.4500
2728	*				N	N			1	1	0		13.4500
2731		3	17		N	N	8	2	0	3	11		13.4500
2733		2	12		N	N	6	1	2	4	6 *		13.4500
2734		3	16		N	N	8	8	4	7	6 *		13.4500
2735		3	20		N	N	10	9	0	9	5 *		13.4500
2736		3	17		N	N	8	6	0	9	5 *		13.4500
2738		2	11		N	N	5	4	0	2	7		13.4500
2750	*	2	10		A	NA	2	3	0	0	8		9.4500
2752	*	2	6		A	NA	2	1	0	3	1		9.4500
2754					C	NA	1	1	3	1	0		9.4500
2756		1	6		B	NA	2	2	0	2	3		9.4500
2757	*				B	NA	2	5	2	4	1 *		9.4500
2758					B	NA	1	1	2	3	1 *		9.4500
27514	*	6	14		A	NA	5	9	2	8	0		9.4500
27575		1	4		B	NA	1	1	0	0	3		9.4500
27576		1	4		B	NA	2	1	0	0	3		9.4500
27577		1	7		B	NA	3	1	0	0	3		9.4500
JS 50					N			0	0	0	0		224.7500

TOTAL WEIGHT FOR SUGGESTED ORDER QTY- 18,725.46

An example of same printing at 15 characters per inch and 8 lines per inch (condensed printing of same information on 11 x 8.5 inch form).

An example of printing at 10 characters per inch and 6 lines per inch (on 14.8 x 11 inch form).

Printing speeds: Up to 560 lines per minute at 10 characters per inch (depending on model)
 Up to 420 lines per minute at 15 characters per inch (depending on model)

Form widths:	76.2 millimeters (3.0 inches) to 450.0 millimeters (17.7 inches)
Form lengths:	76.2 millimeters (3.0 inches) to 317.5 millimeters (12.5 inches)
Form copies:	Single-part (one sheet) or multipart (two to four sheets, with or without carbon). Five and six parts may be used, but must be tested.
Form type:	Continuous, fan-fold, with margin feed holes

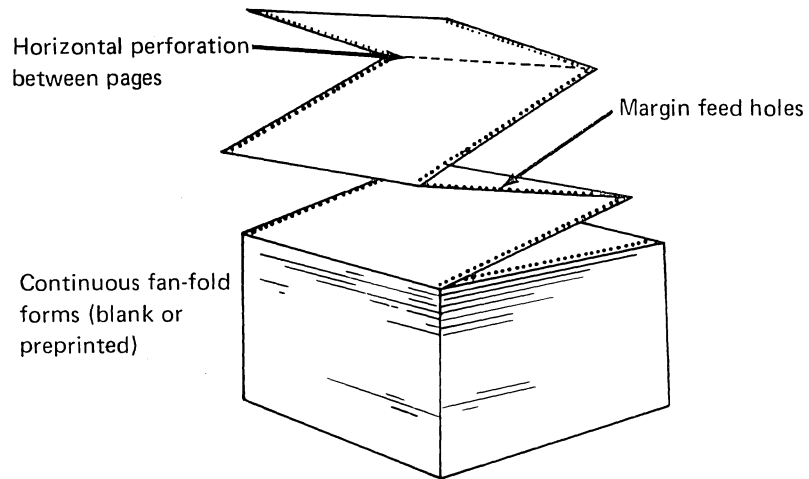

See *Forms Design Reference Guide for Printers*, GA24-3488, for complete forms specifications.

The Computer System

Your printer is connected to a computer system that provides the information to be printed. In this book, the computer is called the “host.” The printer may be physically near the host, or in a remote location.

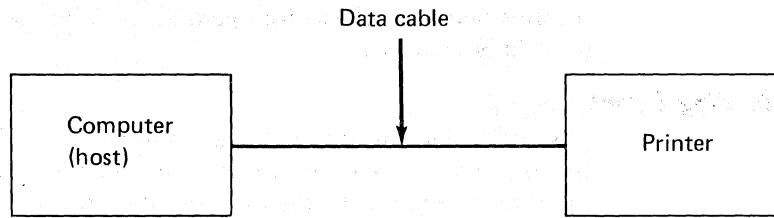

Your printer may be the only device connected to the host, or it may be one of several printers or other devices.

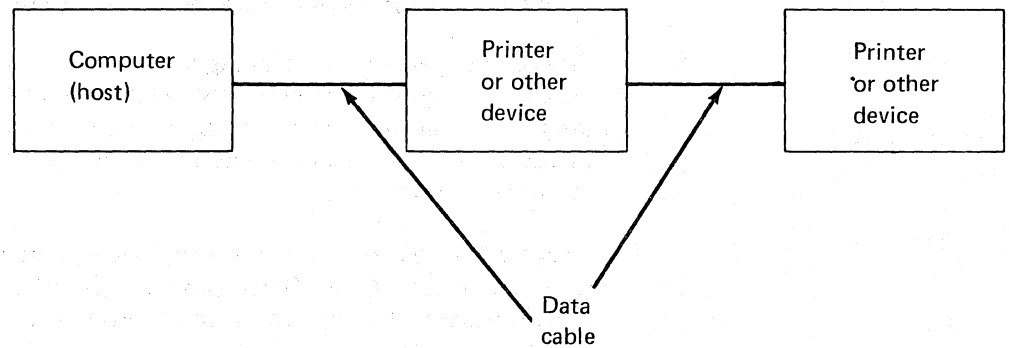

If your printer is one of several devices attached to the host, it must have its own identity (address) which the host uses when communicating with your printer. This address is set with address switches (on the customer access panel) when the printer is set up.

Your Job as Operator

Your job as printer operator is loading and unloading forms, changing the ribbon, operating the printer, solving printer problems, and caring for the printer.

Your printer has a power switch, a mode switch, an operator's panel, and forms controls that you will use for operating it. Chapter 2 provides descriptions of all the printer controls.

Loading and Unloading Forms

You will be loading and changing forms as needed for different printing jobs. During forms loading, you will have to adjust the printer so that printing starts at a specific position (first character print position and first print line). This is most important when loading preprinted forms where the printer fills in the blanks. Chapter 3 gives you step-by-step instructions for loading and unloading forms.

Replacing the Ribbon and Ribbon Shield

Chapter 4 contains information about how to tell when the ribbon needs replacing, and how to replace it and the ribbon shield.

Operating the Printer

Chapter 5 gives you detailed procedures for operating the printer.

One of your printer's outstanding features is its ability to let you know its status. When the printer is switched on, it makes an initial test of itself (the automatic test). After the automatic test, the printer continually checks its condition. During this automatic testing and continuous checking, the printer displays its condition in the status indicators.

Chapter 5 is especially useful to you since it contains a list of the status indicators for each possible status. When you are in doubt about the printer's status or if you think the printer has a problem, go to "Recognizing Printer Status" in Chapter 5. If the status indicates a problem, "Recognizing Printer Status" refers you to Chapter 6 to solve the problem.

Solving Printer Problems

Chapter 6 contains a problem recovery procedure for you to use if the printer has a problem. Chapter 6 also includes information for solving print quality problems. If you need to request service, you will also find a checklist for recording the information needed by IBM service personnel.

Caring for The Printer

Your printer requires very little maintenance, but the following suggestions are helpful for preventing damage to your printer and for keeping it clean:

- Do not place containers of liquid on top of the printer.
- Use only mild soap and warm water to clean the exterior of the printer.
- Vacuum, as necessary, to remove dust and lint from the forms feed path.

Chapter 2. Printer Controls

Contents

Mode Switch	2-3
Online Position	2-3
Buffer Print Position	2-3
Test Position	2-3
Positions 2-9, A-E	2-3
Operator's Panel	2-4
Power Switch	2-5
Attention Light	2-5
Ready Light	2-6
Display	2-7
2nd Mode Key	2-8
One Line/Start Key	2-9
Stop Reset Key	2-10
Space Key	2-10
Density/Display Key	2-11
Cancel/New Page Key	2-12
Forms Feed Controls	2-13
Tractors	2-14
Alignment Scale	2-15
Horizontal Adjustment Control	2-16
Vertical Adjustment Control	2-16
Forms Feed Release Latches	2-17
Thickness Control	2-18
Stacking Guides	2-19
Optional Controls	2-20
Audible Alarm	2-20
Cable-Thru	2-20
Address Switches	2-21
Terminator Switch	2-21

This chapter describes the Mode Switch, the operator's panel, the forms feed controls, and the optional controls.

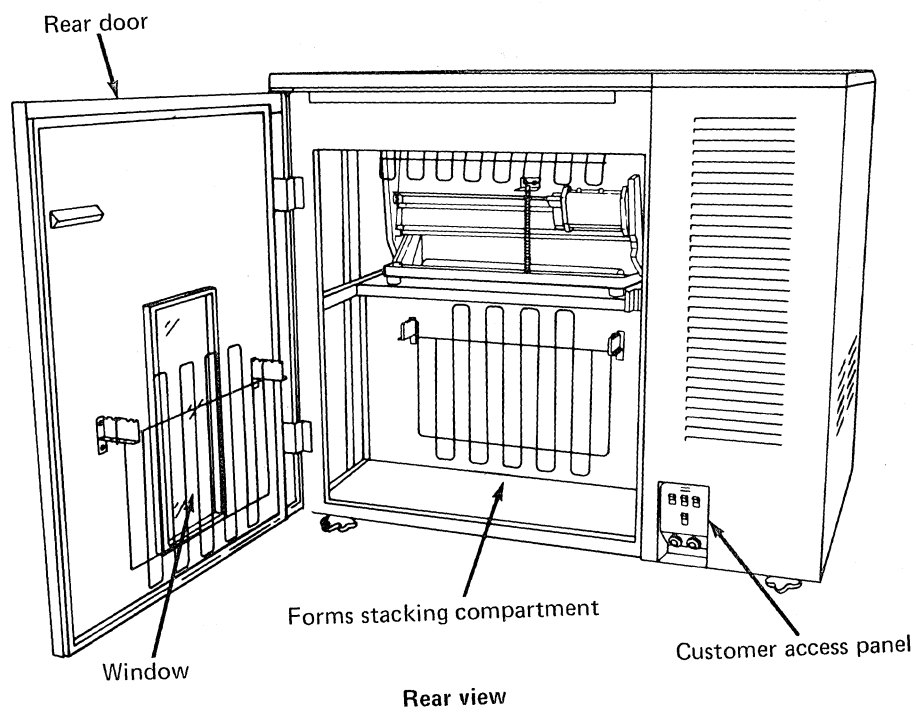
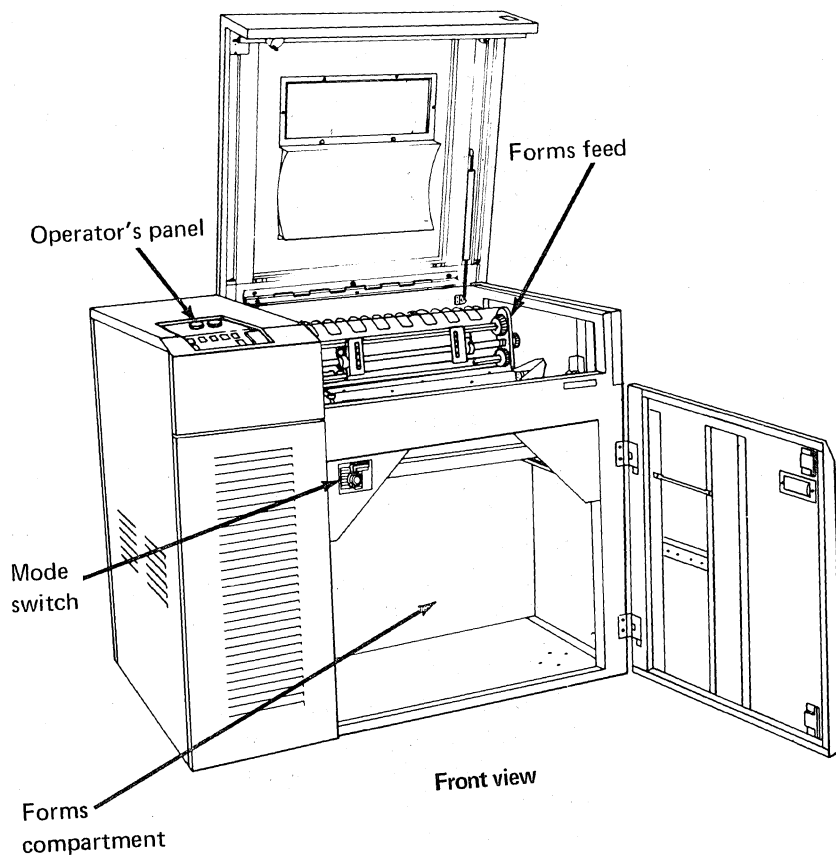

Mode Switch

The Mode Switch is a 16-position switch, located behind the front door, with which you select the function you want the printer to perform.

The printer is *online* and printing is controlled by the host when the Mode Switch is in the Online or Buffer Print position; the printer is *offline* and printing is controlled by you or service personnel when the Mode Switch is in any other position.

You will use only the Online, Buffer Print, and Test positions. Chapter 5 gives details for using these positions. The remaining positions are used by service personnel.

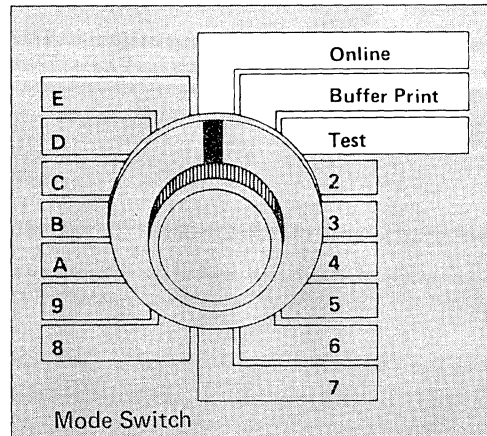

Online Position

This is the normal operating position. In the Online position, the printer can communicate with the host.

Buffer Print Position

This position is used by system programmers and service personnel for analyzing application programs and pinpointing problems. In the Buffer Print position, the printer communicates with the host, and all printer commands and data are printed, but the commands are not executed.

Test Position

You may use this position to check certain printer functions before placing the printer online. The Test position prints a page of test data. An example of the test page is shown and described in Chapter 5.

Positions 2-9, A-E

The remaining 13 positions are used by service personnel to check all printer functions.

Operator's Panel

The operator's panel has:

- Some of the common status codes and all the density codes and their meanings **A**
- Two lights **B**, Ready and Attention, that show you when the printer is ready for normal operation and when it needs attention
- A one-character display **C** that shows either a status or a density code
- A power switch **D** with which you switch the printer power on and off
- Six keys (push buttons) **E**, three of them dual-function, that you use to operate the printer

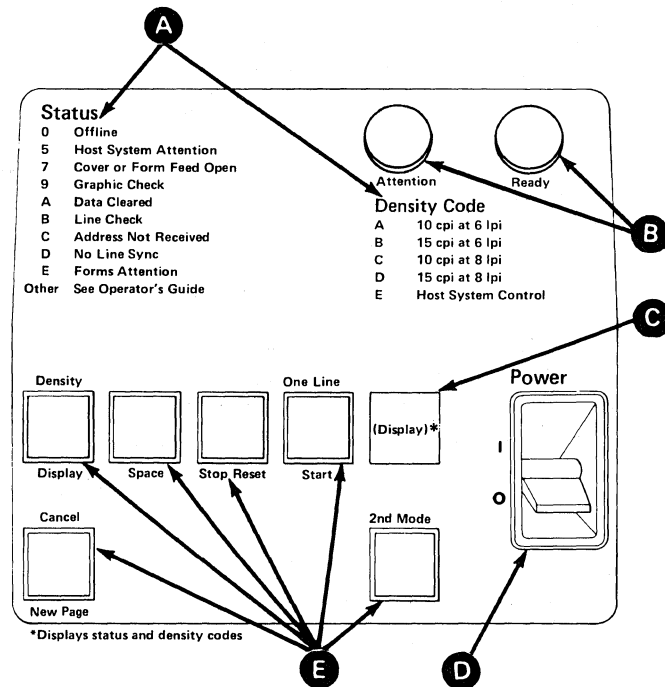

Power Switch

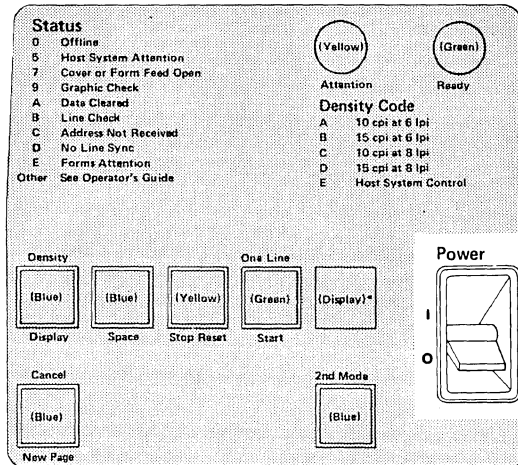

Placing the Power switch in the | (on) position switches on the printer power; placing the Power switch in the O (off) position switches off the printer power.

Attention Light

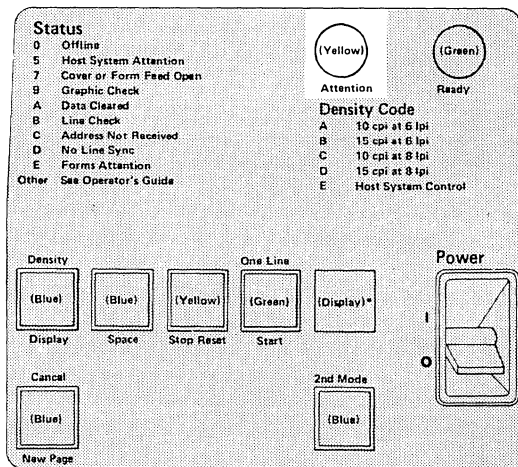

If the yellow Attention light is on, one of the following conditions exists:

- The Mode Switch is in an offline position.
- A printer status requires attention (see Chapter 5).

Ready Light

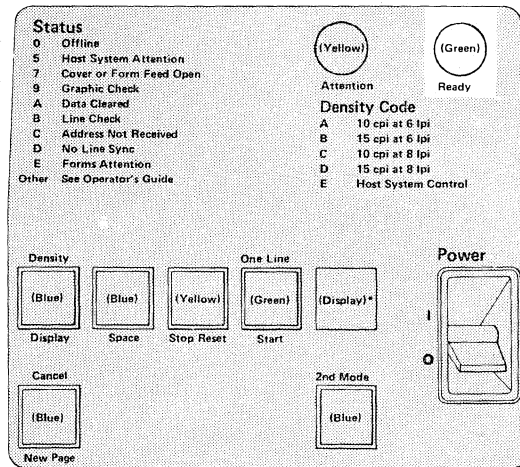

When the green Ready light is on and the printer is online (the Mode Switch is set to Online or Buffer Print), the printer is ready to print data it receives from the host.

When Ready is on and the Mode Switch is in the Test position, the printer prints a test page while checking certain printer functions.

Ready is switched on by pressing the Start key; it is switched off by pressing the Stop Reset key or when certain conditions occur.

When Ready is on, the only keys you can use on the operator's panel are Cancel and Stop Reset.

Display

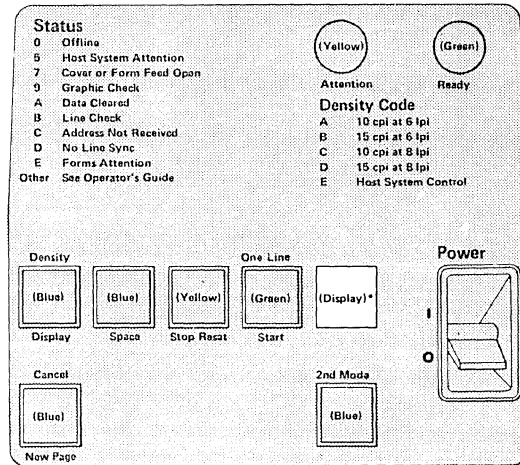

*Displays status and density codes

This single-character display shows either a density or a status code.

The meanings of some of the status codes and all of the density codes that can be displayed appear on the operator's panel. See Chapter 5 for a complete list and explanation of the status codes. Density codes are discussed later in this chapter, under "Density/Display key."

2nd Mode key

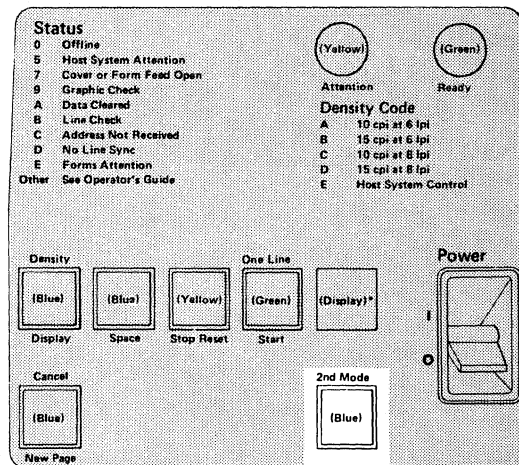

Use the 2nd Mode Key:

- By itself, to place the second character of a status code in the display (see Chapters 5 and 6).
- With a dual-function key, to shift to the function shown above the dual-function key. This is done by pressing and holding the 2nd Mode key while pressing a dual-function key. The three dual-function keys are Density/Display, One Line/Start, and Cancel/New Page.

One Line/Start Key

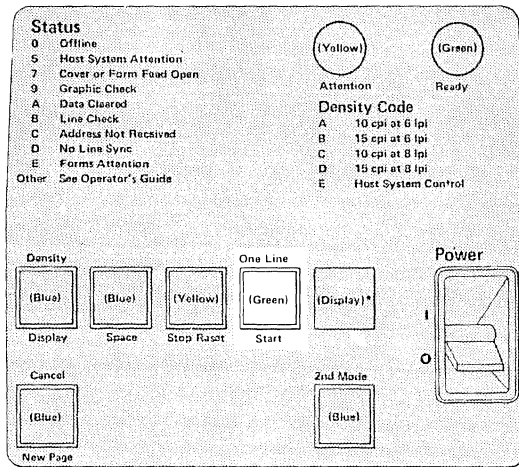

Pressing the Start key causes the Ready light to come on and begins the function selected by the Mode Switch. The display must show 0, C, D, or blank for this to occur.

Pressing the One Line key while pressing the 2nd Mode key causes the Ready light to come on and prints one line if the following conditions exist:

- The Mode Switch is in the Online or Buffer Print position.
- The display shows C, D, or blank.
- The printer has received data from the host.

Stop Reset Key

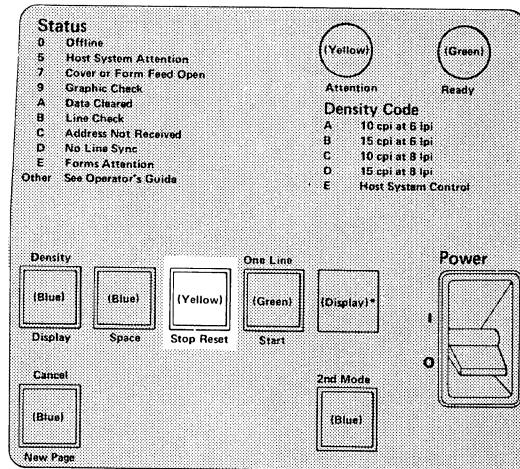

The Stop Reset key has two purposes. Pressing the Stop Reset key stops the printer after completion of the line being printed or at the end of forms movement. The Ready light goes off and the Attention light is on.

Pressing the Stop Reset key while the Ready light is off resets the status code being displayed.

Space Key

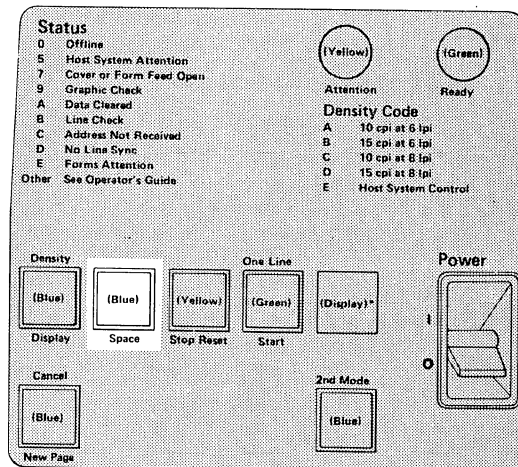

Pressing the Space key advances the forms one line if the Ready light is off and the display shows a 0, C, D, or blank.

Density/Display Key

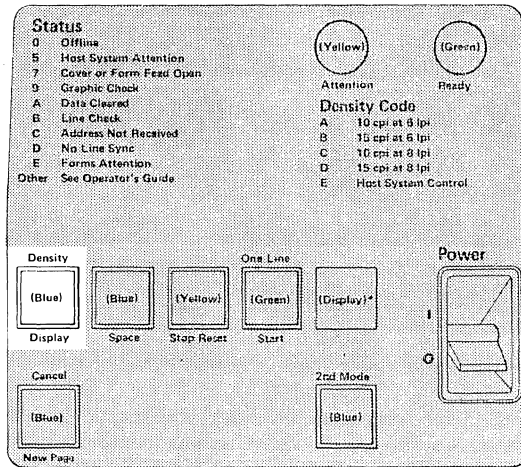

Pressing the Display key displays the current density code. The Ready light must be off and the display must be 0, C, D, or blank for this to occur.

Code Means that the print density is:

- A 10 characters per inch at 6 lines per inch
- B 15 characters per inch at 6 lines per inch
- C 10 characters per inch at 8 lines per inch
- D 15 characters per inch at 8 lines per inch
- E Under control of the host system

Pressing the Density key while pressing the 2nd Mode key advances the print density to the next sequential code. The Ready light must be off and the display must be 0, C, D, or blank for this to occur.

The printer operates at the print density set by the host or the operator. The following chart shows when print density codes can be set:

Set to code	Host when the printer is online and ready	Operator when the printer is offline and not ready	Operator when the printer is online and not ready
A*	Yes	Yes	Yes
B	Yes	Yes	Yes
C	Yes	Yes	Yes
D	Yes	Yes	Yes
E	Yes	No	Yes**

*Code A is set when the printer is switched on.

**When you select code E, the code previously chosen by the host (A, B, C, D, or E) is set. If the host has not made a choice, code A is set.

Cancel/New Page Key

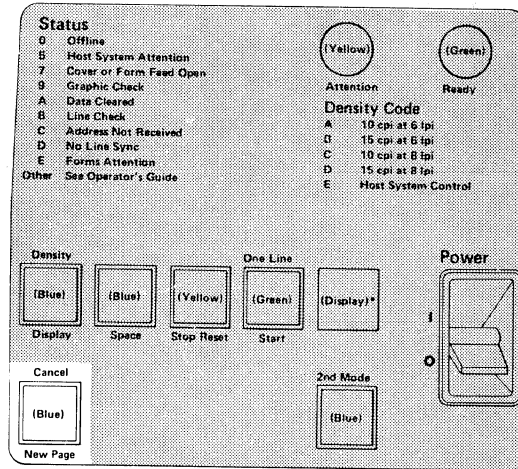

Pressing the New Page key advances the forms to the first print line of the next form. The Ready light must be off and the display must be 0, C, D, or blank for this to occur. In addition, the printer must have received a command from the host defining the page length according to the physical forms length. If this command is not received, or if the printer is offline, the forms advance only one line.

You also use the New Page key when aligning the first print line during forms loading. (See the procedure in Chapter 3.)

The Cancel key is used with the 2nd Mode key for changing the printer from offline to online, or for requesting the host's attention while the printer is online and ready. (See the procedures in Chapter 5.)

Forms Feed Controls

Raising the top cover makes the forms feed controls accessible.

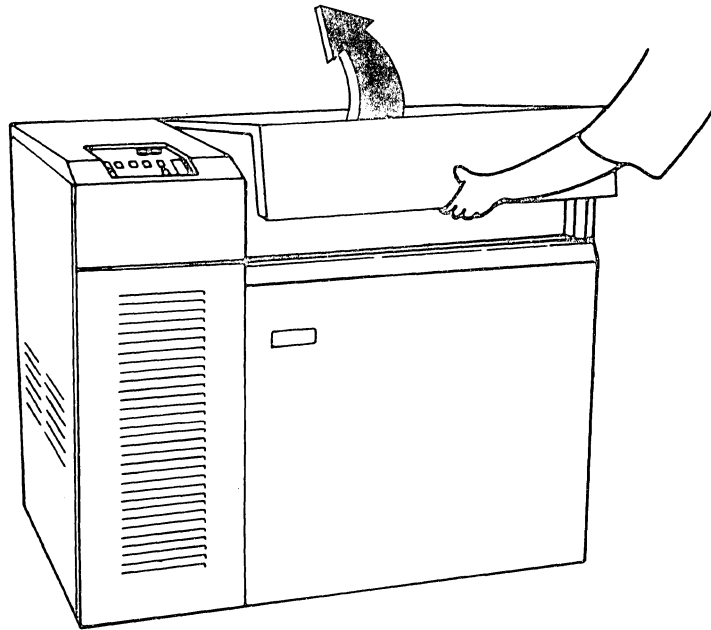

This section gives you an overview of the forms feed controls that you use when loading or unloading forms, and when replacing the ribbon or ribbon shield.

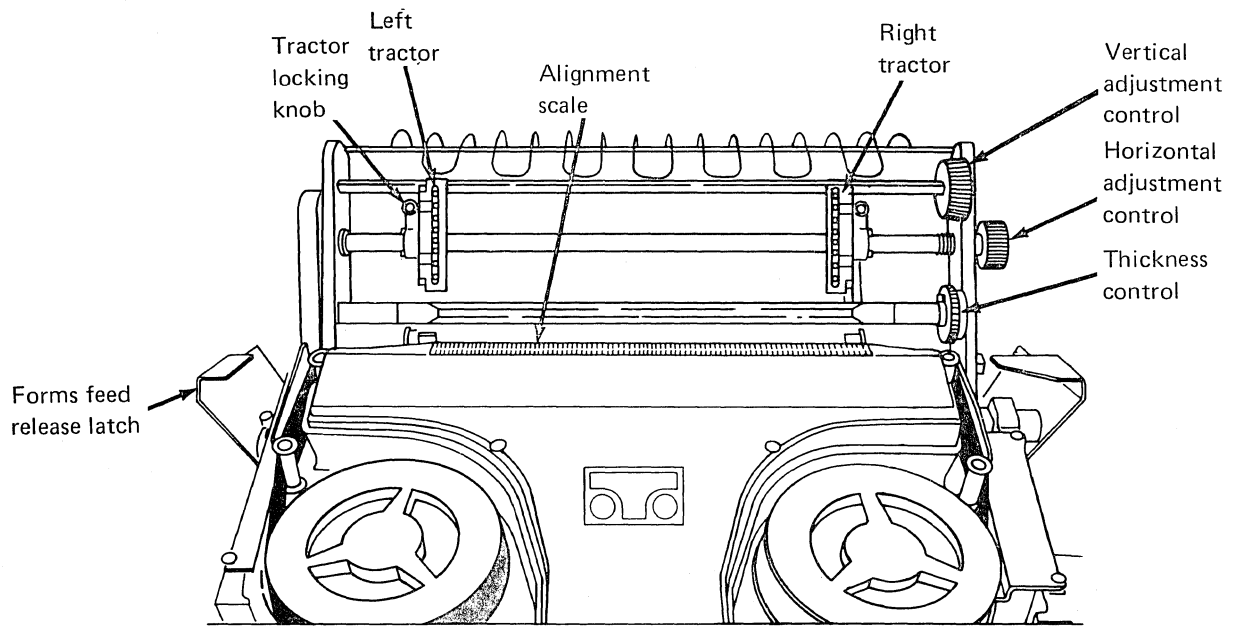

Tractors

The forms margin holes fit onto the tractor pins that move the forms through the printer, while the tractor covers hold the forms onto the tractors.

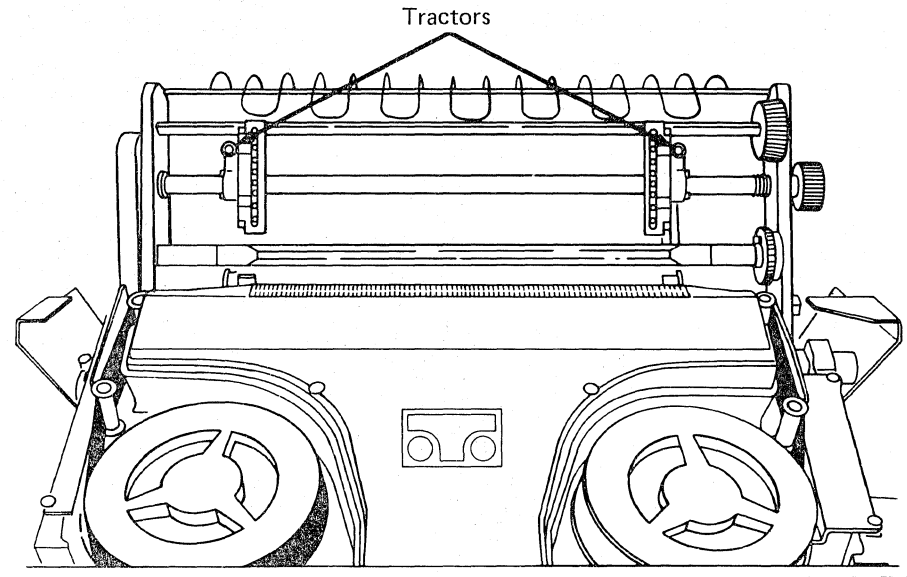

Loosening the tractor locking knobs allows the tractors to be moved so that forms of different widths can be used.

Turning the knobs counterclockwise loosens the tractors; turning the knobs clockwise tightens them.

Both the left and right forms tractors can be moved in either direction; however, the left tractor's movement is restricted to 71 millimeters (2.8 inches). The right tractor's movement is 362 millimeters (14.3 inches).

Alignment Scale

The alignment scale is used for aligning the print positions horizontally. The upper scale measures 10 characters per inch, extending from 0 to 132 characters, and the lower scale measures 15 characters per inch, extending from 0 to 198 characters.

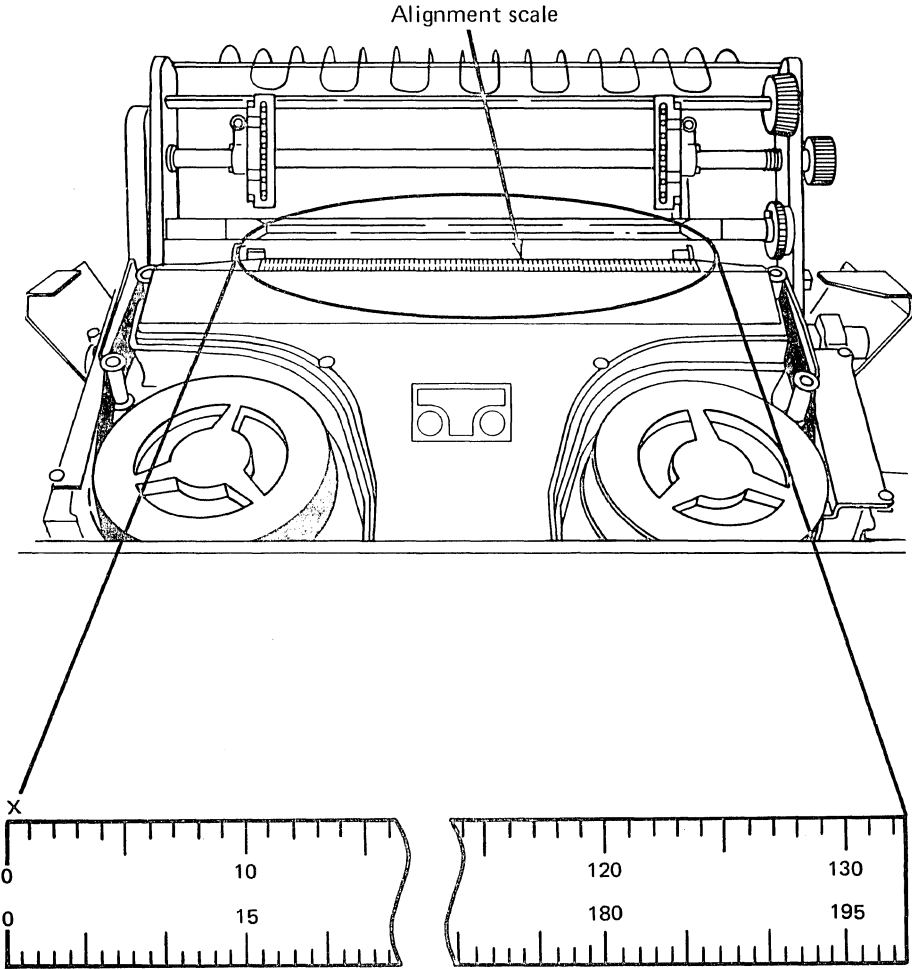

The first possible print position (X) is between the 0 and the 1 mark on the alignment scale.

Horizontal Adjustment Control

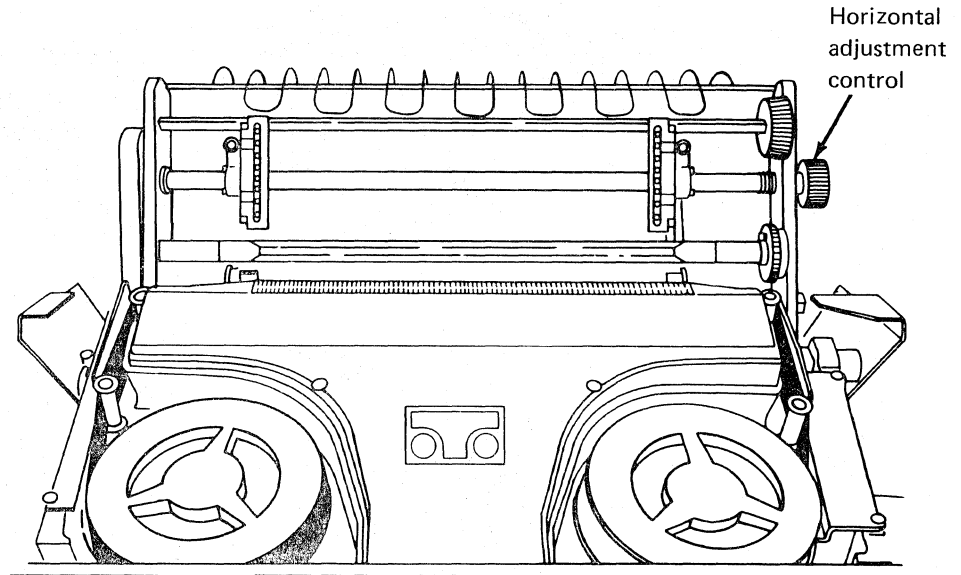

Turning the horizontal adjustment control moves both tractors in the same direction for fine horizontal alignment of the forms when aligning the print positions. The total span of movement is approximately 15 millimeters (0.6 inch). The horizontal adjustment control is used with the alignment scale.

Vertical Adjustment Control

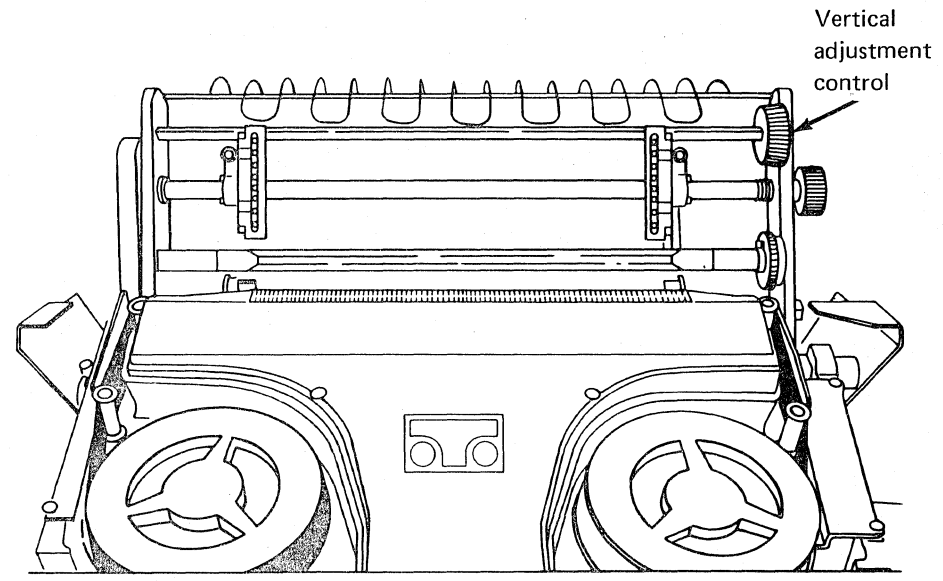

Turning the vertical adjustment control moves the forms vertically.

Forms Feed Release Latches

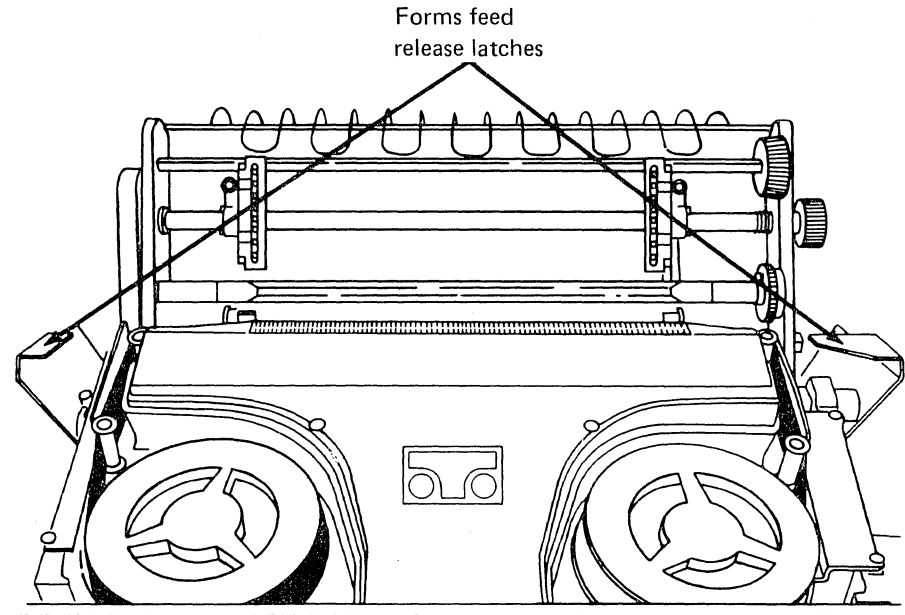

Pushing both forms feed release latches downward opens the forms feed for loading or unloading forms, and for changing the ribbon and ribbon shield.

Thickness Control

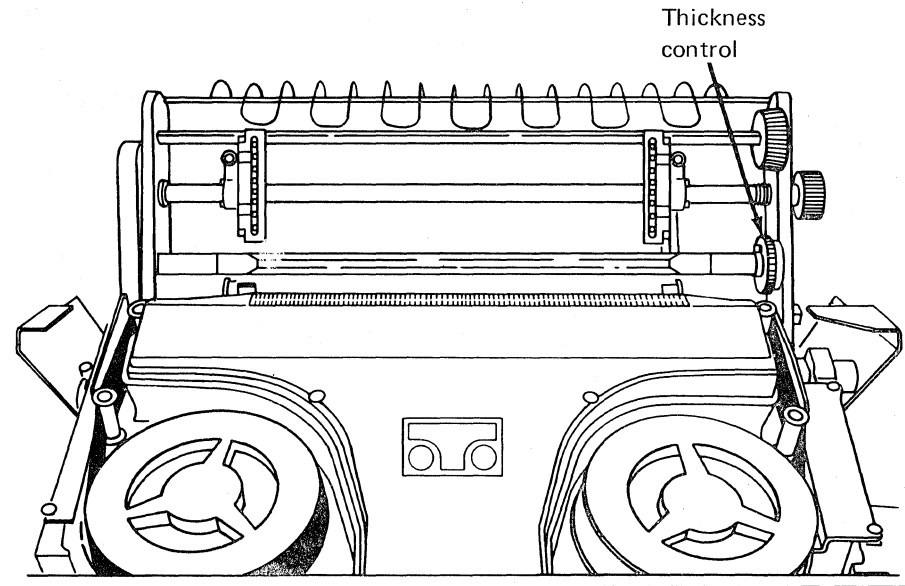

Turning the thickness control adjusts the print impressions on the forms. The correct thickness control setting depends on the forms thickness, type, quality, size, and number of copies. (See "C. Adjusting the Thickness Control" in Chapter 3.)

Stacking Guides

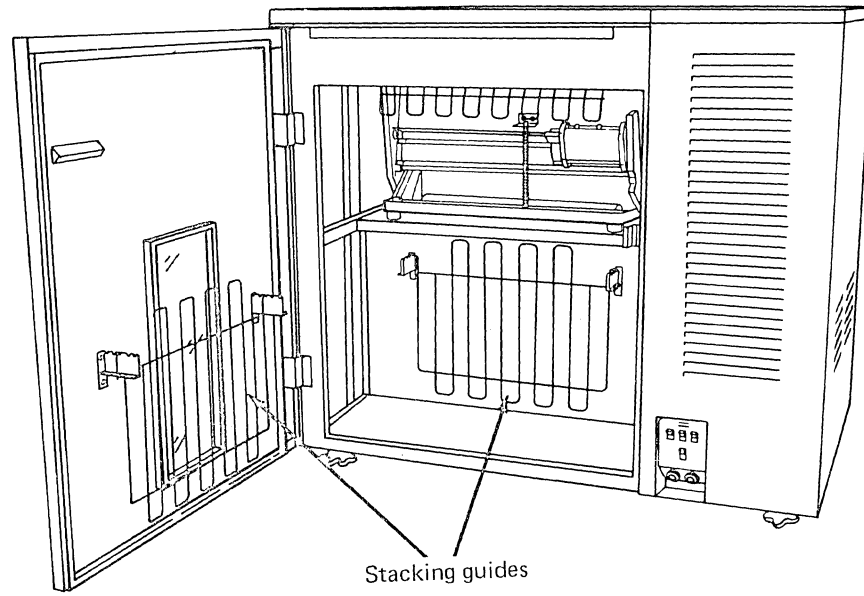

The two stacking guides inside the rear door are adjustable to accommodate forms of various lengths (between folds).

Optional Controls

Two optional controls are available: an Audible Alarm feature and a Cable-Thru feature. If the printer has either of these features, the associated controls are located on the customer access panel at the rear of the printer.

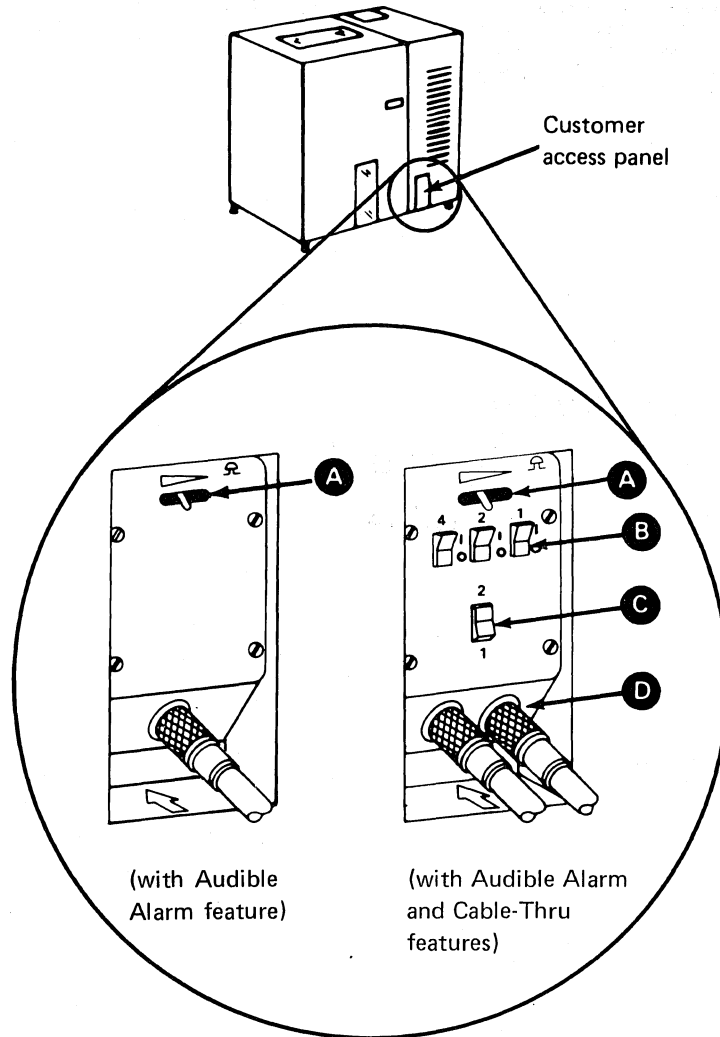

Audible Alarm

The audible alarm emits short “beeps” when the printer needs attention. A volume control **A** for the alarm can be adjusted from the highest volume, on the extreme left, to the lowest volume, on the extreme right. The audible alarm may be turned off by pressing the Stop Reset Key.

Cable-Thru

The Cable-Thru feature allows the connection of multiple devices to the same host. The Cable-Thru feature consists of a set of three address switches **B**, a terminator switch **C**, and two cable connectors **D**.

Address Switches

The two position (| or O) rocker-type address switches establish the address of your printer. These switches were set when your printer was set up. The following illustrations show the switch positions for addresses 0 through 6. A printer address of 7 is invalid.

Note: If your printer does not have the Cable-Thru feature, its address is automatically 0 and cannot be changed.

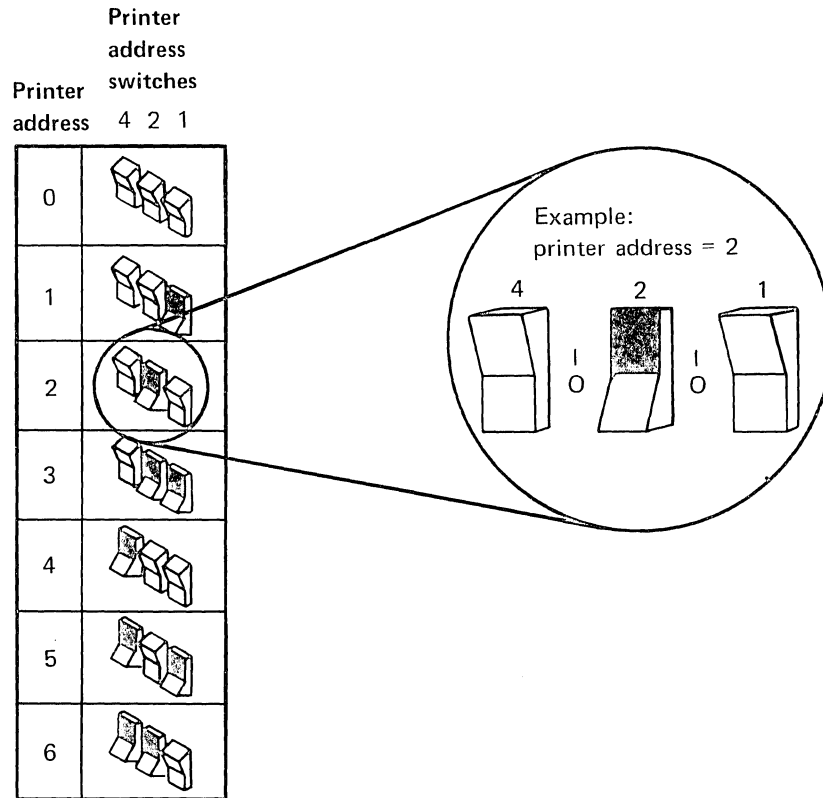

Terminator Switch

The terminator switch must be set to position 1 if only one cable is connected to the printer. If two cables are connected to the printer, the terminator switch must be set to position 2.

Chapter 3. Loading and Unloading Forms

Contents

Loading Forms	3-3
Preparing to Load Forms	3-3
Inserting the Forms	3-6
Adjusting the Thickness Control	3-10
Setting the First Print Position	3-12
Setting the First Print Line	3-14
Adjusting the Stacking Guides	3-17
Unloading Forms	3-19

This chapter describes loading and unloading forms. The loading procedure consists of the following major steps:

- A. Preparing to load forms
- B. Inserting the forms
- C. Adjusting the thickness control
- D. Setting the first print position
- E. Setting the first print line
- F. Adjusting the stacking guides

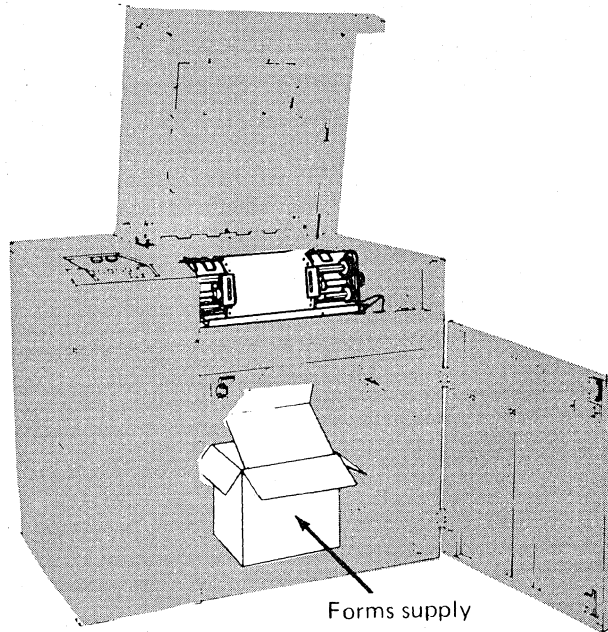

Front view with forms loaded

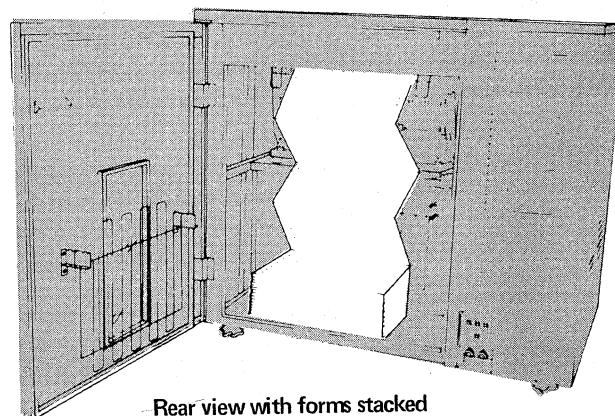

Rear view with forms stacked

Loading Forms

A. Preparing to Load Forms

1. Switch on the printer power and wait until the automatic test is completed (approximately 30 seconds).
2. Raise the top cover.

Note: The printer cannot operate with the top cover open. This is for your safety. If the printer has the audible alarm (optional), press the Stop Reset key to switch off the alarm.

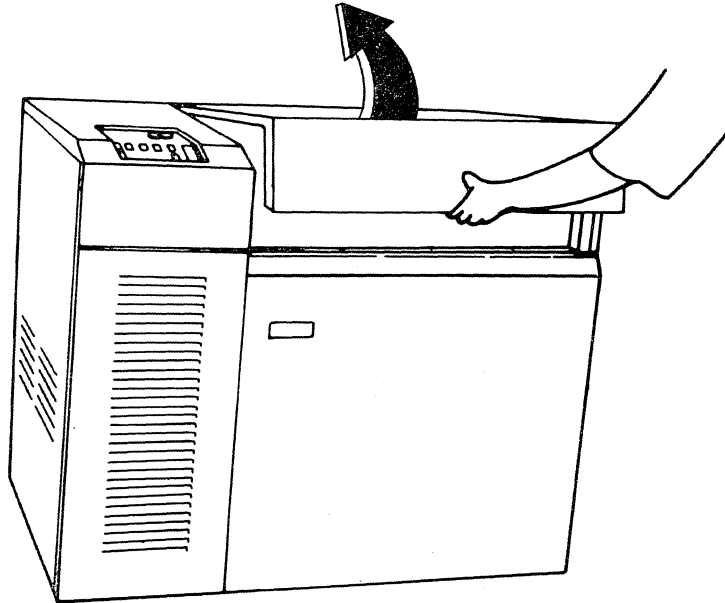

3. Loosen the tractor locking knob **A**, and move the tractor to the right until it stops.

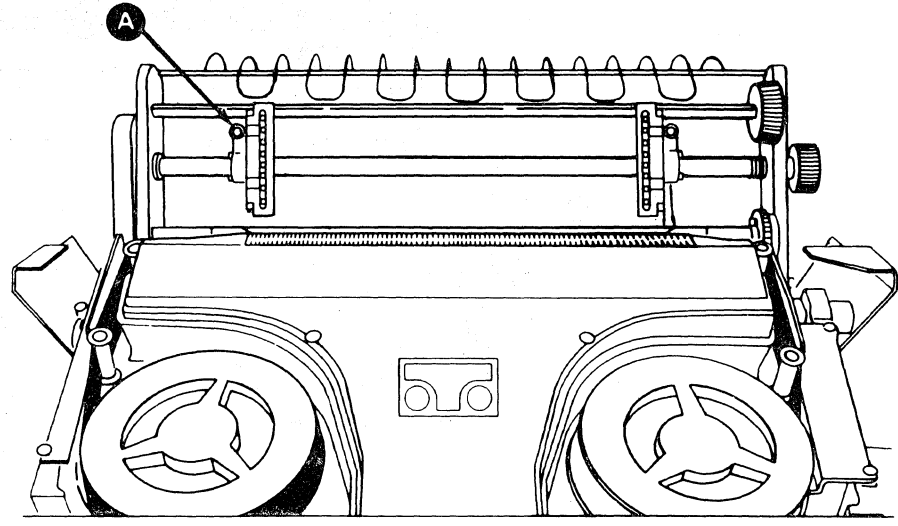

4. Raise the left tractor cover.

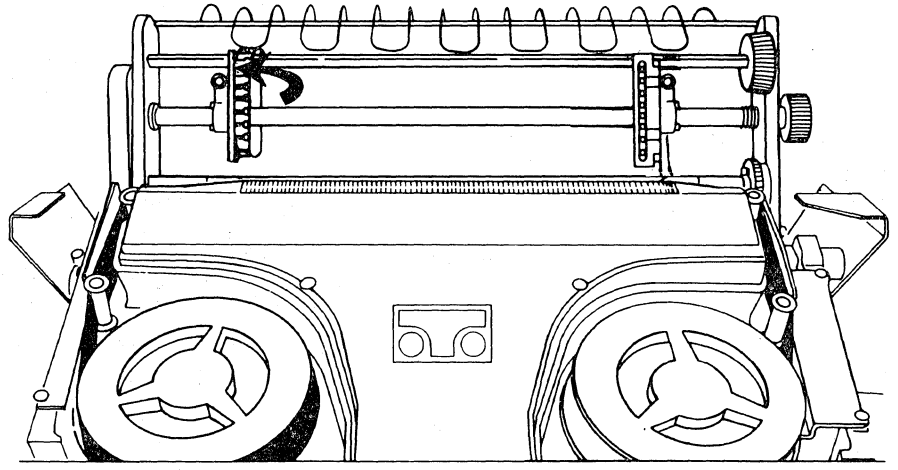

5. Release the forms feed by pushing down on the release latches **B**.

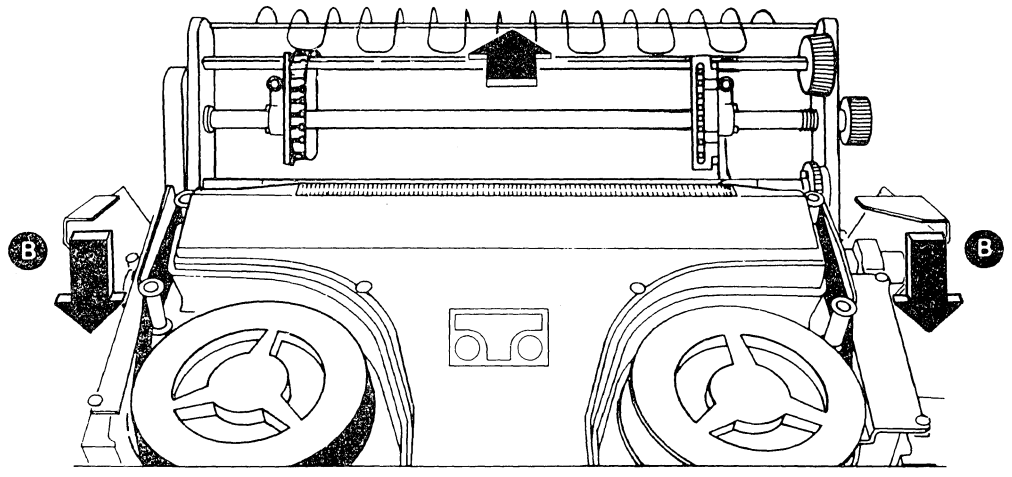

6. Pull the tension fingers toward the front of the printer.

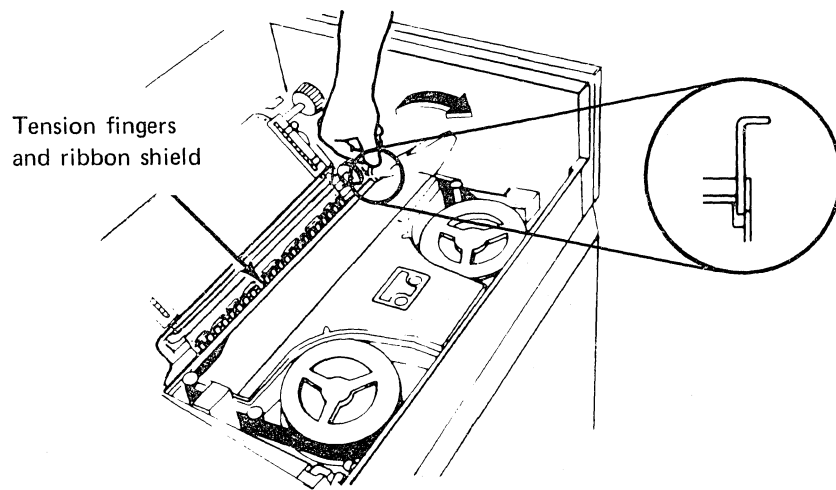

B. Inserting Forms

1. Open the front door.

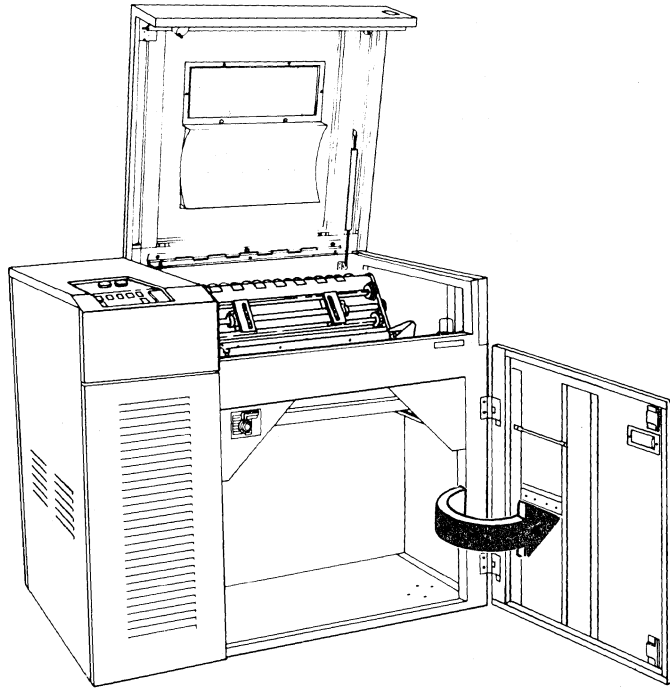

2. Position the forms supply so that the side to be printed on is toward you.

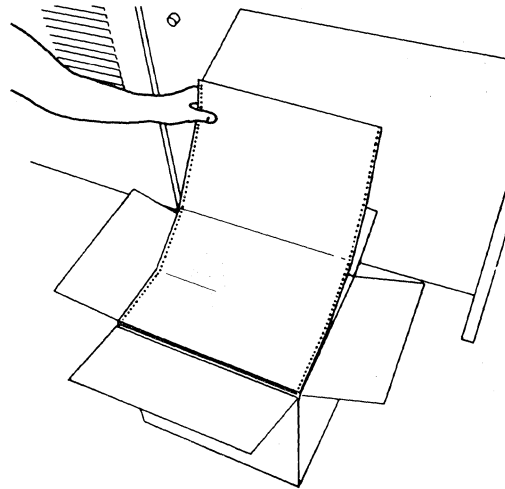

3. Place the forms into the forms compartment, and roughly align the left edge of the forms with the left tractor pins.

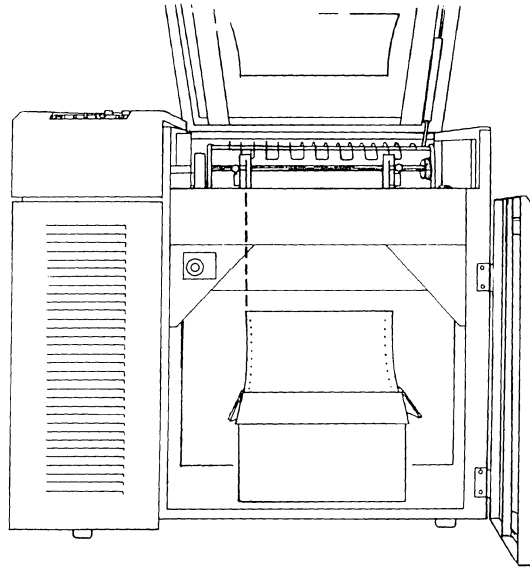

4. Feed the forms up between the forms feed and tension fingers.

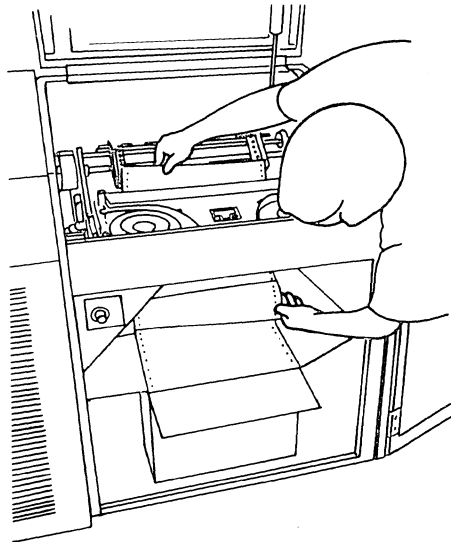

5. Place the form's left margin holes over the left tractor pins, close the tractor cover, and tighten the tractor knob.

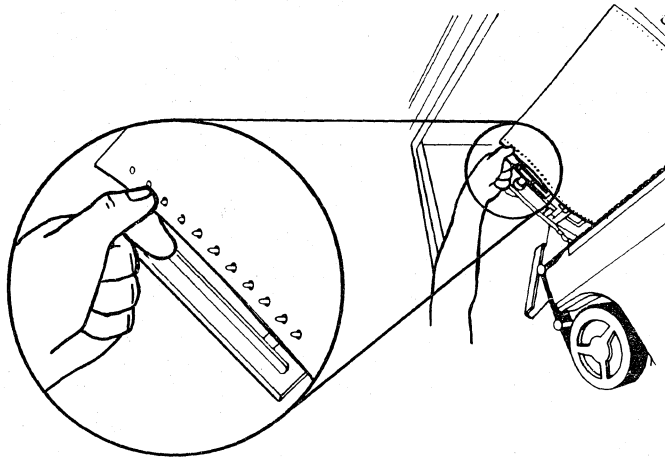

6. Loosen the right tractor locking knob **(c)**, open the tractor cover, and align the tractor pins with the right margin holes of the forms.

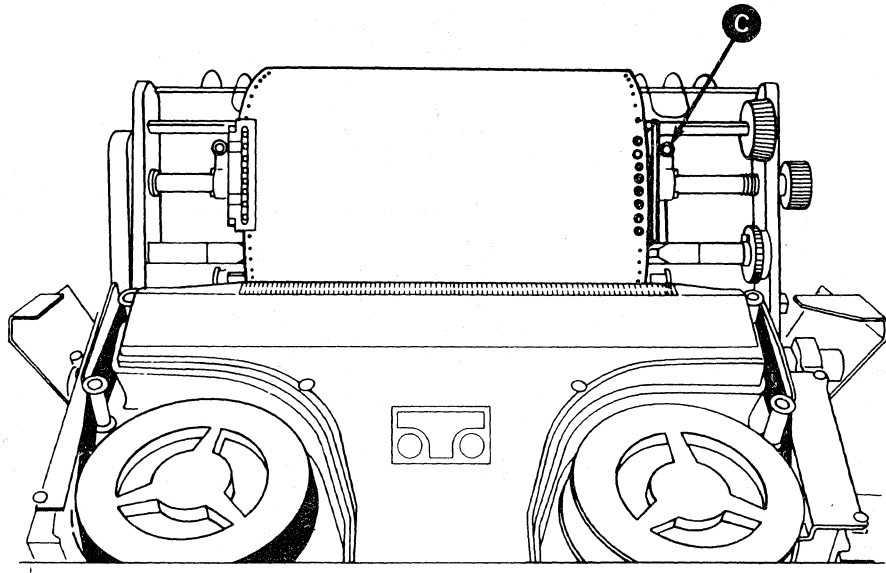

7. Place the form's right margin holes over the right tractor pins. Close the tractor cover and tighten the tractor locking knob.

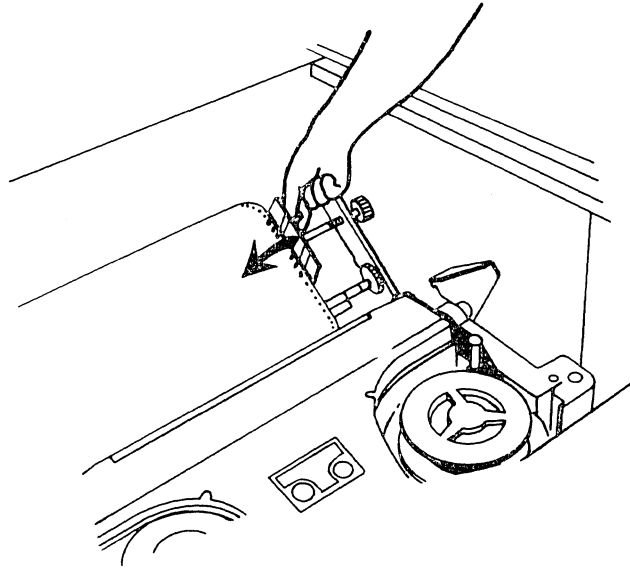

Note: If forms are wider than 375 millimeters (14.8 inches), you may have to readjust the left tractor.

8. Loosen the left tractor locking knob **D** and move the left tractor until no slack remains in the forms between the tractors. Tighten the locking knob.

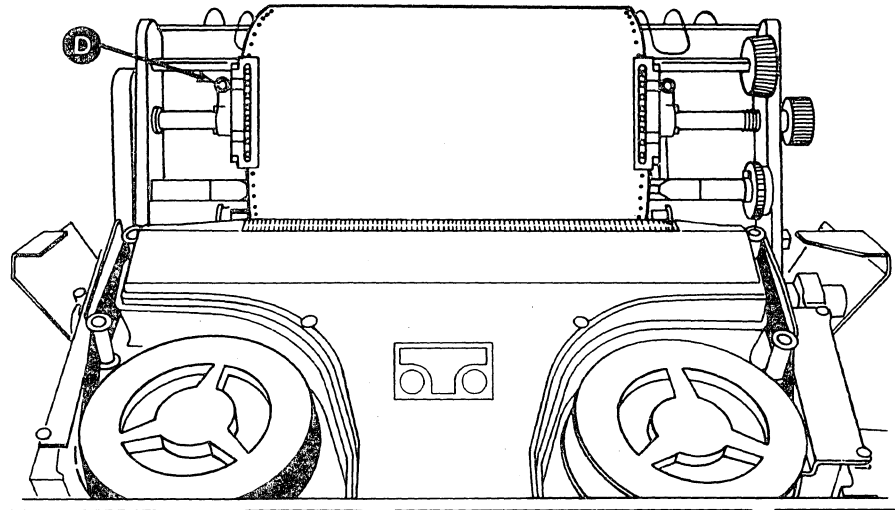

Note: If you are using multipart forms, ensure that the tractor pins fit completely through all the margin holes.

C. Adjusting the Thickness Control

1. Use the following chart as a guide to initially set the thickness control to match the type of forms you are using. Always reset the thickness control whenever you load a different type of form.

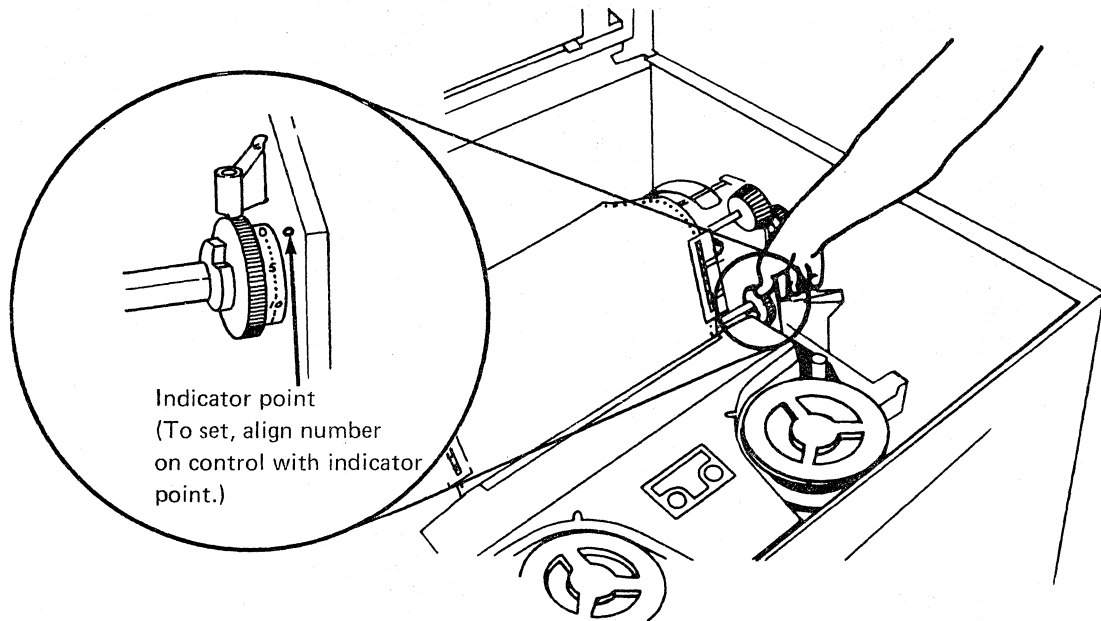

Kind of forms	Thickness control setting
Single-part	0-3
Two-part	4-6
Three-part	6-8
Four-part	9-12
Five-part	13-16
Six-part	17-19

Warning: Actual settings depend on forms thickness variations. If the setting is too low, ribbon smudging may occur; if the setting is too high, light, incomplete, missing printing, or ribbon damage may occur.

Use the lowest setting that does not cause ribbon smudging.

2. Be sure that the forms move freely by turning the vertical adjustment control.

If the forms do not move freely, check for:

- Proper positioning of the forms supply
- Too much slack in the forms
- Proper thickness control setting

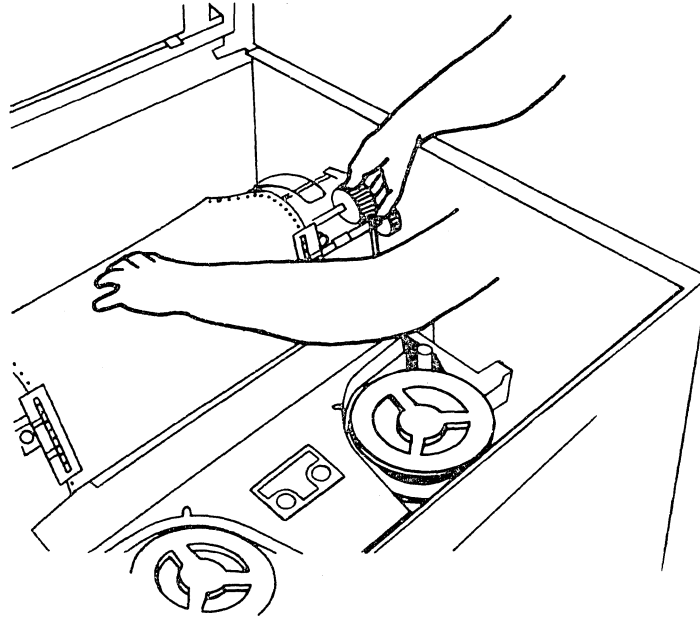

D. Setting the First Print Position

1. If you are using preprinted forms, roughly align the first print line. If you are using blank forms, proceed to step 2.

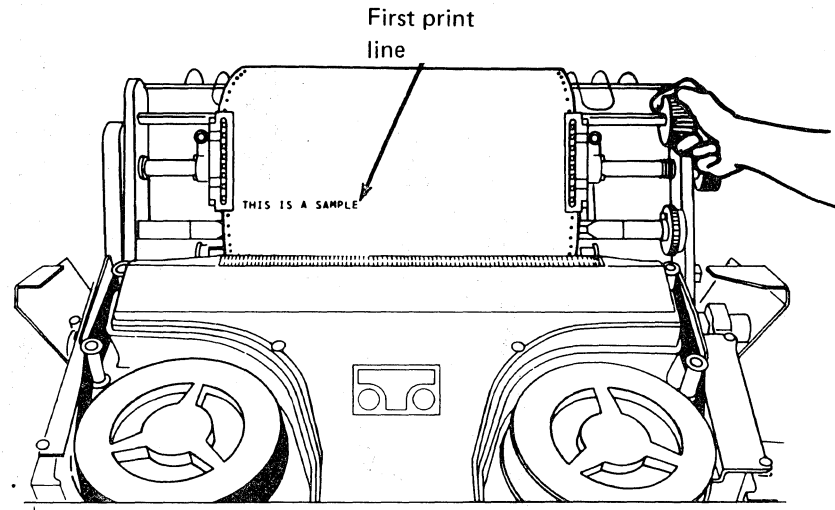

2. Push the tension fingers to the rear of the printer.

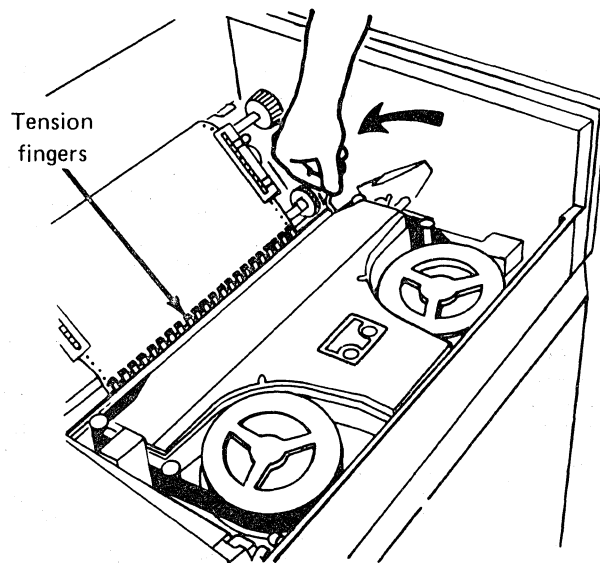

3. Close the forms feed by pulling it toward the front of the printer until it is locked in place.

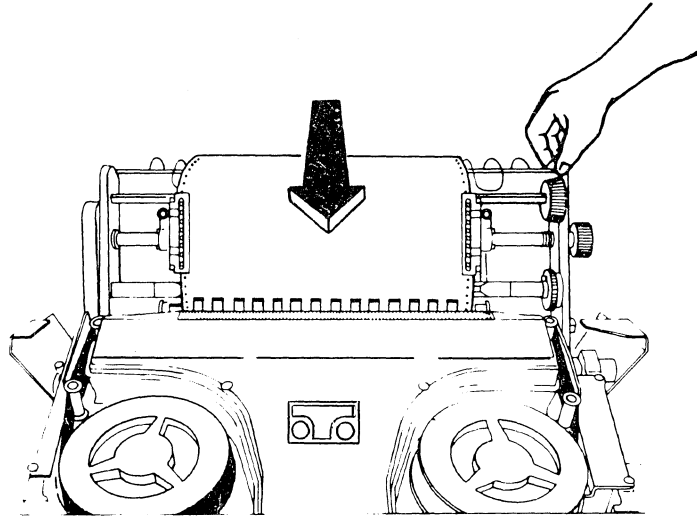

4. Turn the horizontal adjustment control to align the first print position with the forms alignment scale.

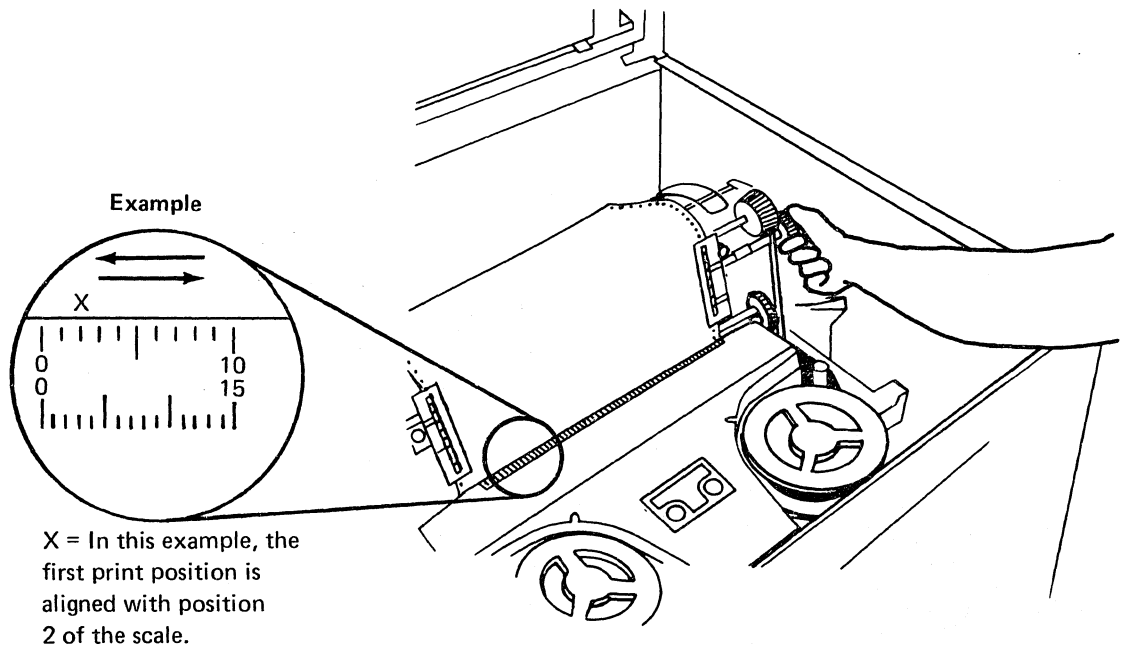

X = In this example, the first print position is aligned with position 2 of the scale.

E. Setting the First Print Line

Note: The first print line is set with the forms feed open.

1. Release the forms feed by pushing down on the release latches **G**.
2. Pull the tension fingers toward the front of the printer. (See "A. Preparing to Load Forms," step 6).
3. Turn the vertical adjustment control **F** to move the first print line to position **E**, 70 to 80 millimeters (approximately 3 inches) below the bottom of the left tractor cover.

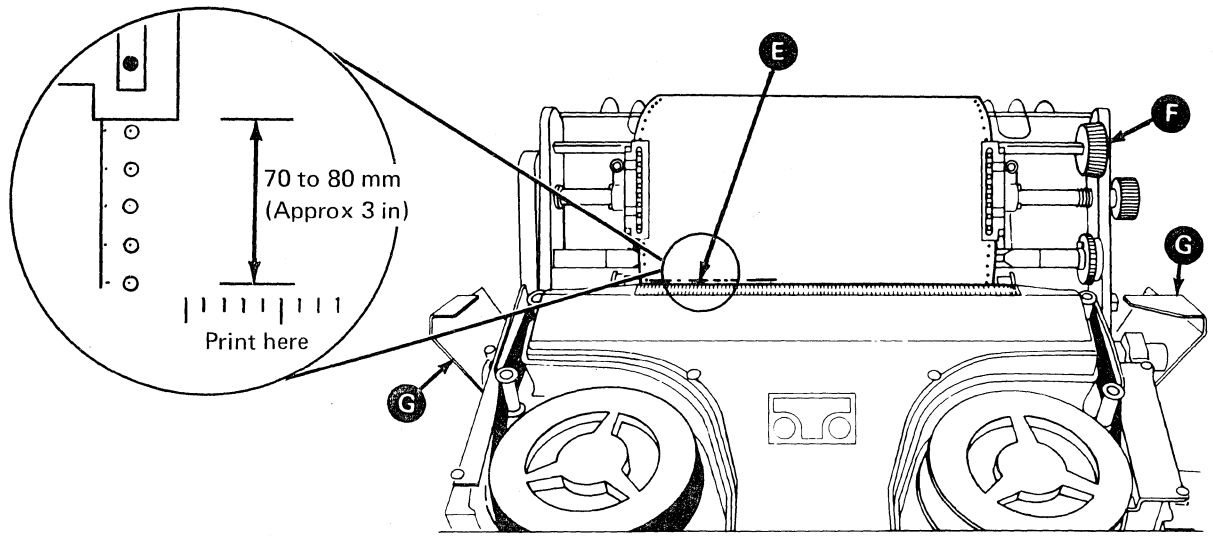

4. Push the tension fingers to the rear of the printer. Be sure the first print line is below the dark area on the tension fingers. If not, pull the tension fingers toward you and turn the vertical adjustment control to lower the first print line more. Then push the tension fingers to the rear and recheck. Repeat this procedure until the first print line is below the dark area.
5. Turn the vertical adjustment control to raise the bottom of the first print line up to the bottom of the dark area on the tension fingers.

Note: The final forms movement should be upward. Downward movement buckles the forms at the tension fingers.

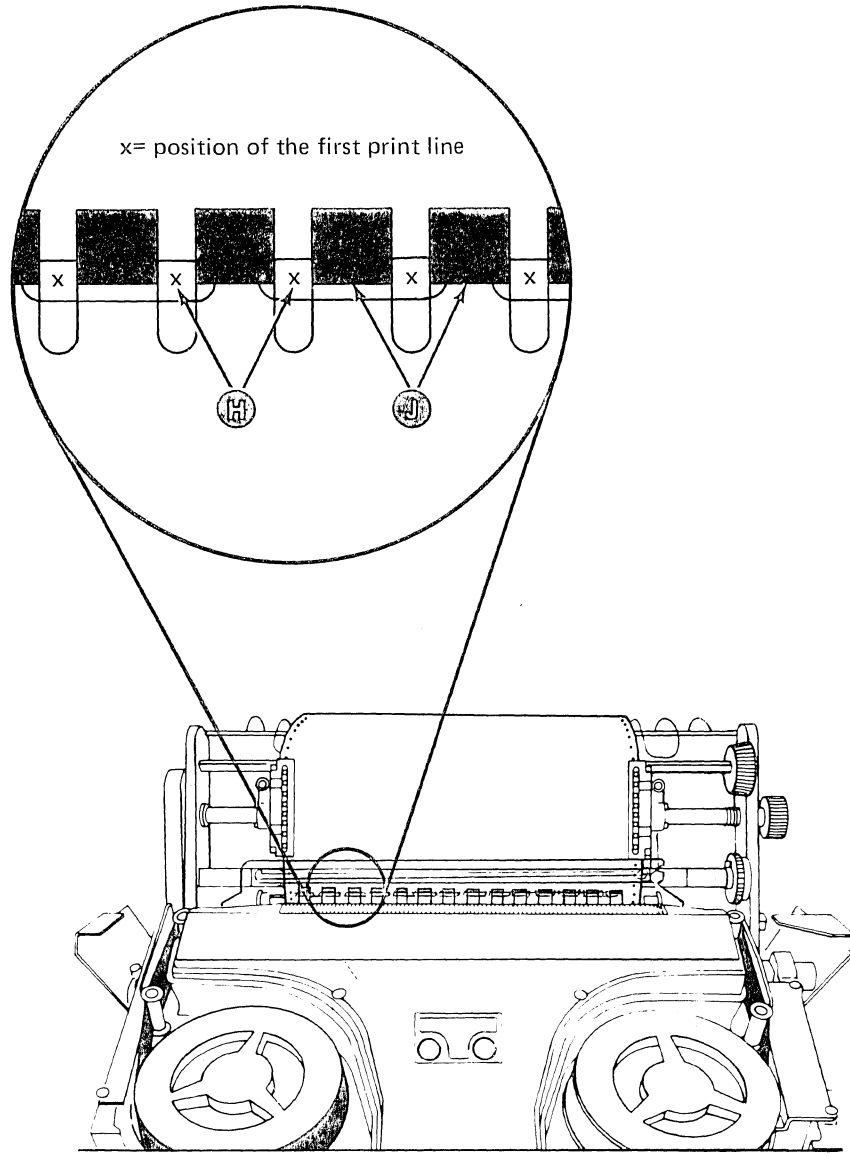

6. Press the New Page key.
7. Close the forms feed by pulling it toward the front of the printer until it is locked in place. (See “D. Setting the First Print Position,” step 3).
8. Close the top cover.

Note: When the top cover is closed, the forms automatically advance 38 millimeters (1.5 inches).

9. Close the front door.

F. Adjusting the Stacking Guides

1. Open the rear door. Position the door-mounted stacking guide and the inner stacking guide according to the forms length.

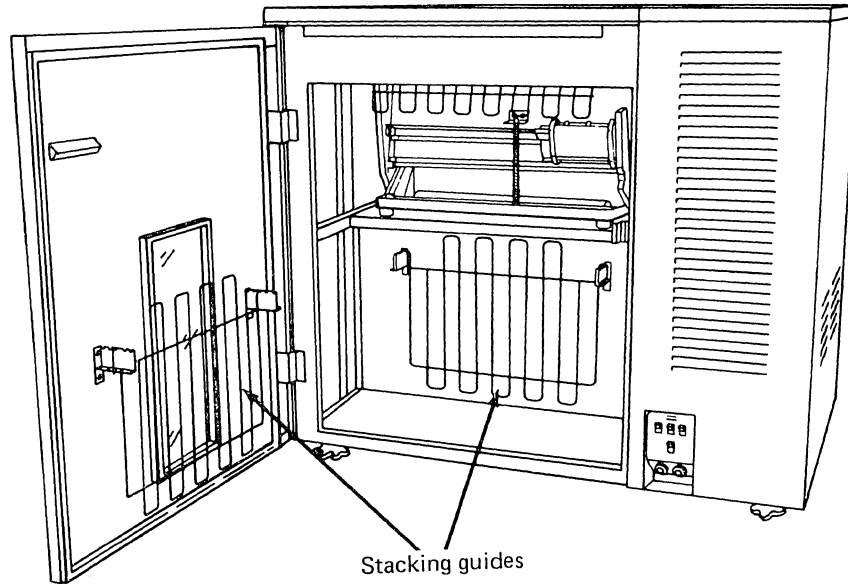

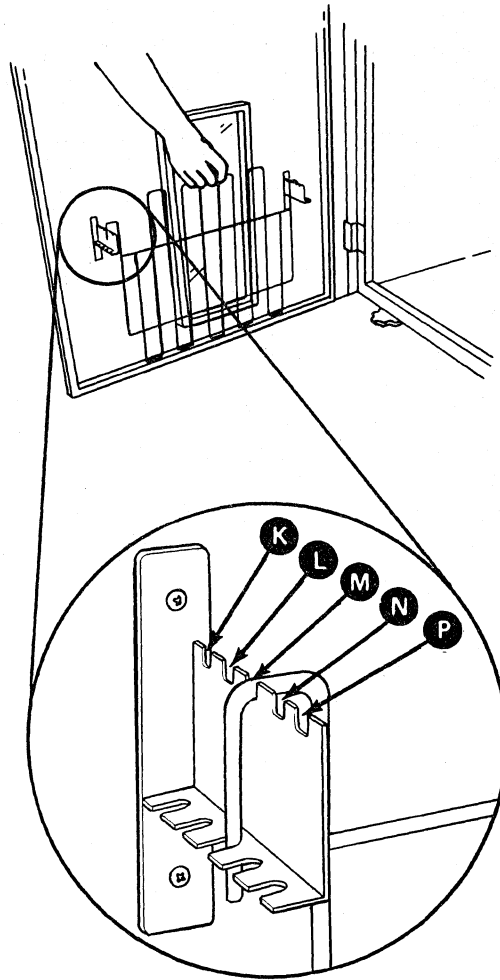

<i>Forms length</i>	<i>Slot on inner guide</i>	<i>Slot on door guide</i>
153-190 mm (6-8 in.)	● P *	● P *
191-120 mm (8-9 in.)	● N	● N
221-250 mm (9-10 in.)	● M	● M
251-280 mm (10-11 in.)	● L	● L
281-305 mm (11-12 in.)	● K	● K
306-318 mm (12-13 in.)	● K	Remove guide

*Slot ● P is nearest the center of the form enclosure.

2. Close the rear door.
3. Once printing begins, check for proper forms stacking. If necessary, open the rear door and adjust the forms and stacking guides for proper forms stacking.

Unloading Forms

1. Open the front door.
2. Raise the top cover.

Note: The printer cannot operate with the top cover open. This is for your safety. If the printer has the audible alarm (optional), press the Stop Reset key to switch off the alarm.

3. Release the forms feed by pushing down on the release latches .

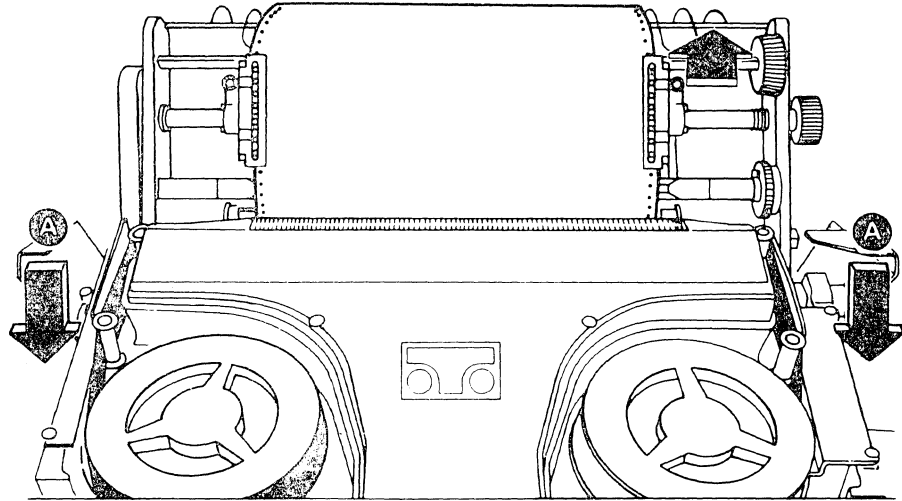

4. Pull the tension fingers toward the front of the printer.

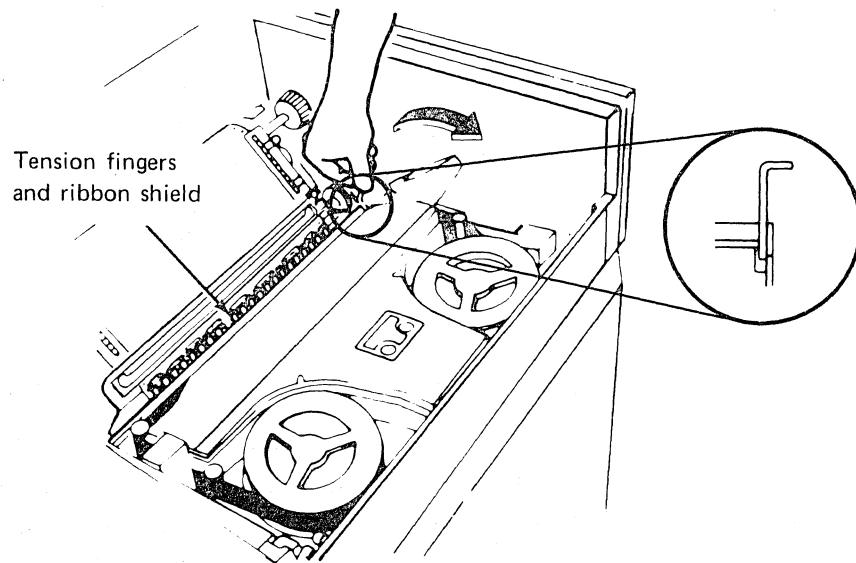

5. Move the bottom of the last printed page above the tractors by turning the vertical adjustment control **B**; then separate the forms by tearing along the perforation.
6. Raise the left and right tractor covers.

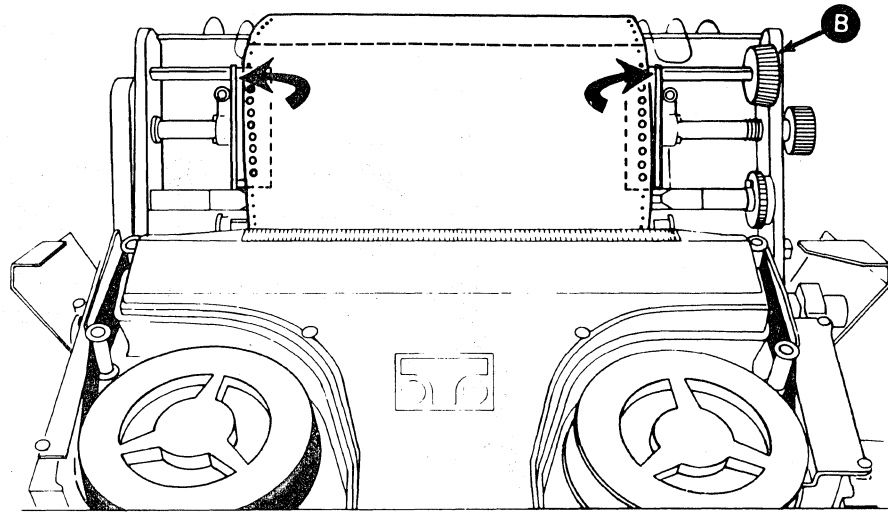

7. Unload the forms by pulling them off of the tractor pins and downward out of the printer.

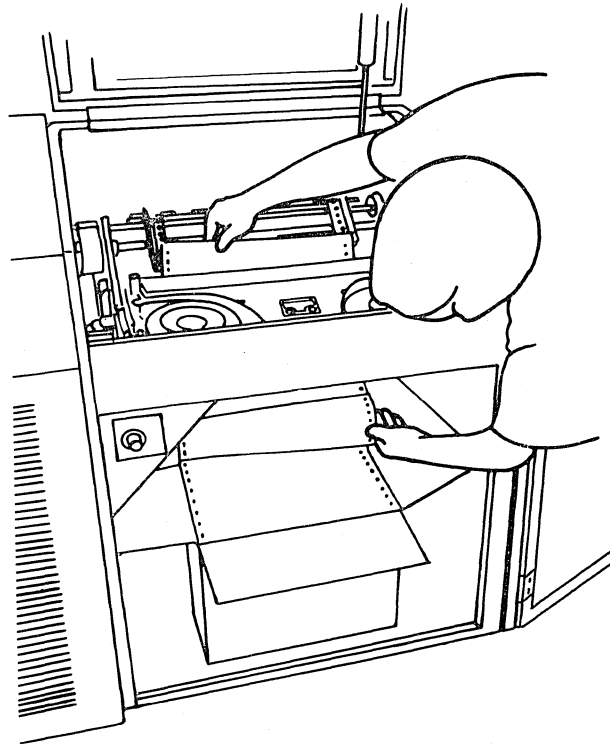

8. Close the forms feed by pulling it toward the front of the printer until it is locked in place.

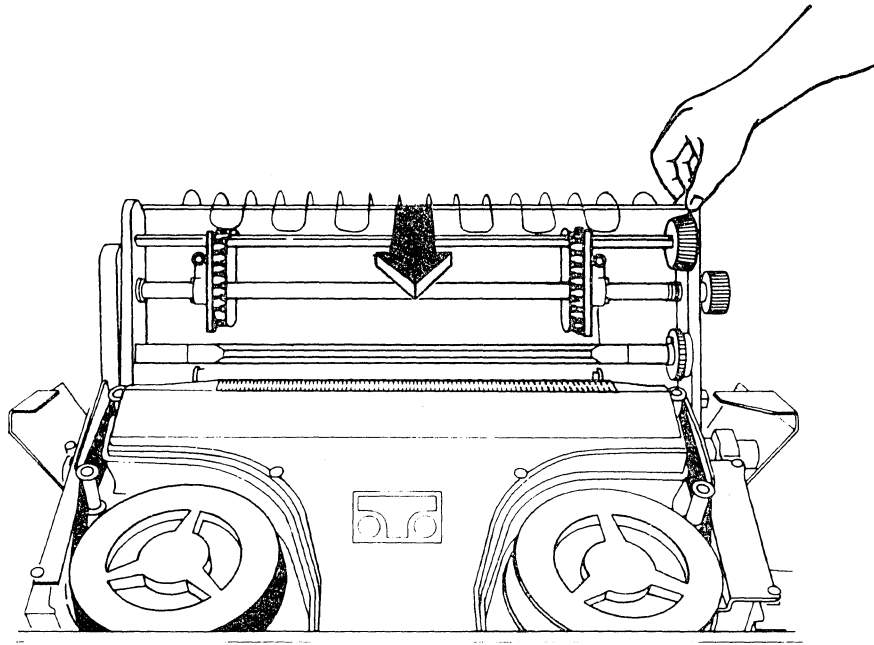

9. Close the tractor covers. (See step 6 for an illustration of the covers.)

Chapter 4. Replacing the Ribbon and Ribbon Shield

Contents

Removing the Ribbon	4-2
Installing the Ribbon	4-3
Removing the Ribbon Shield	4-4
Installing the Ribbon Shield	4-4

This chapter describes how to remove and install the ribbon and the ribbon shield.

If printing is too light or incomplete, the ribbon is folded or frayed, or the ink is exhausted. When any of these conditions exist, change the ribbon.

If printing is light but the ribbon is not folded or is not badly frayed, you may extend the life of the ribbon by turning it over.

Removing the Ribbon

1. Raise the top cover.

Note: The printer cannot operate with the top cover open. This is for your safety. If the printer has the audible alarm (optional), press the Stop Reset key to switch off the alarm.

2. Release the forms feed by pushing down on the release latches **A**.

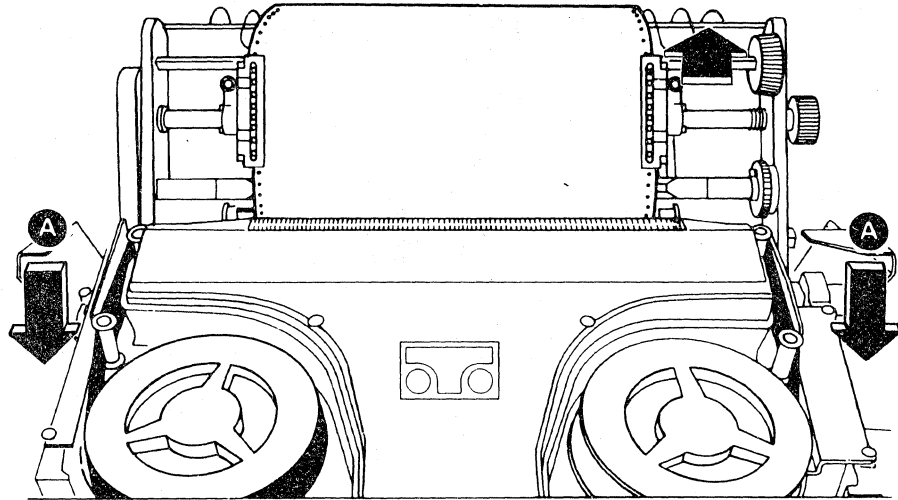

3. Turn one of the ribbon reels **C** to relieve the ribbon tension.
4. Lift the two ribbon reels and the ribbon up and away from the four ribbon guides **B**.

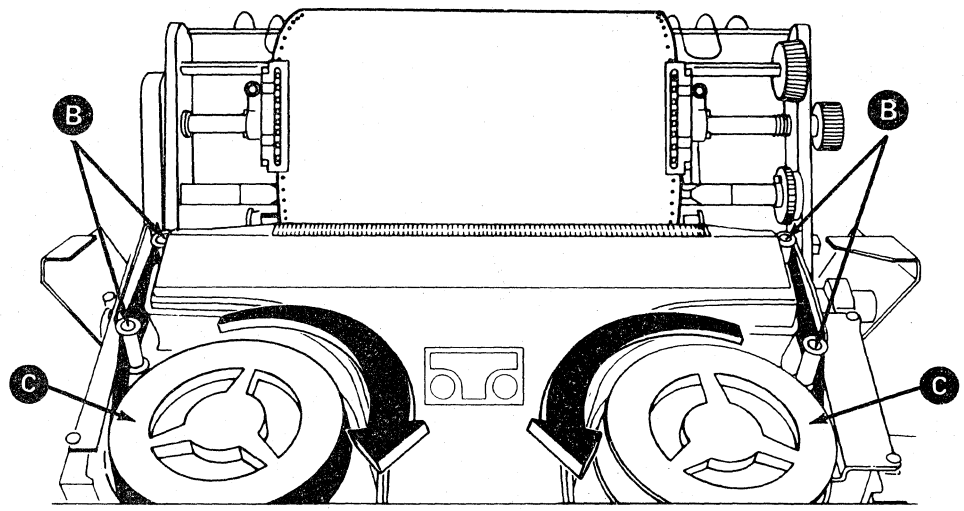

Installing the Ribbon

1. Install one of the new ribbon reels on its spindle.
Note: Use an IBM ribbon, part 4412372, or its equivalent.
2. Loop the ribbon around the four ribbon guides (D) and install the other ribbon reel on its spindle.
3. Be sure that both ribbon reels are fully seated and that there are no twists in the ribbon.
4. Tighten the ribbon around the ribbon guides by turning one of the reels.

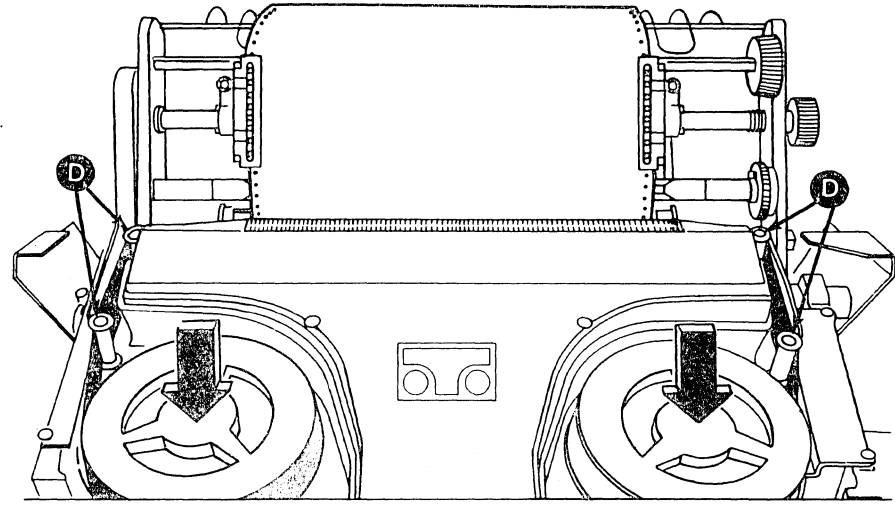

5. Close the forms feed by pulling it toward the front of the printer until it is locked in place.

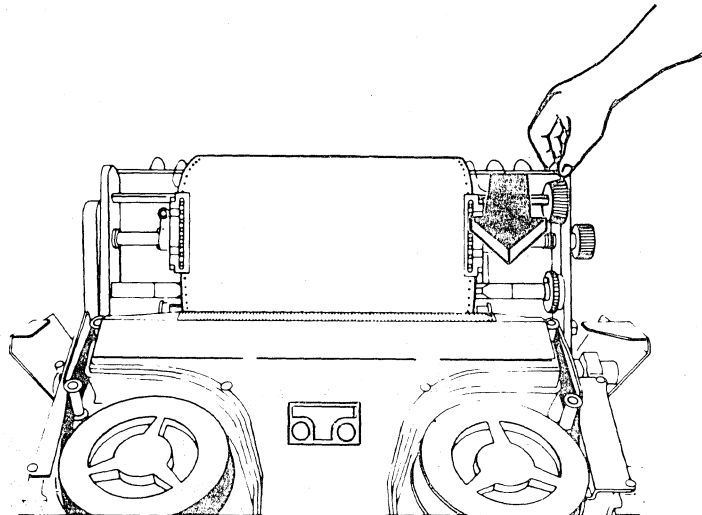

6. Close the top cover.

Removing the Ribbon Shield

1. Raise the top cover.

Note: The printer can not operate with the top cover open. This is for your safety. If the printer has the audible alarm (optional), press the Stop Reset key to switch off the alarm.

2. Release the forms feed by pushing down on the release latches.
3. Remove the ribbon shield **E** from the tension fingers assembly **F**.

Installing the Ribbon Shield

1. Open the printer top cover and the forms feed assembly.
2. Locate the tension fingers assembly.
3. Be sure the base **D** of the tension fingers assembly is clean.
4. Remove the paper strip from the adhesive backing **G** on the shield.
5. Attach the ribbon shield to the front of the tension fingers assembly. The left edge **H** and bottom edges **G** of the shield should touch the angled edges of the tension fingers assembly as shown.
6. Press firmly on the adhesive area **G** to secure the shield to the tension fingers assembly.

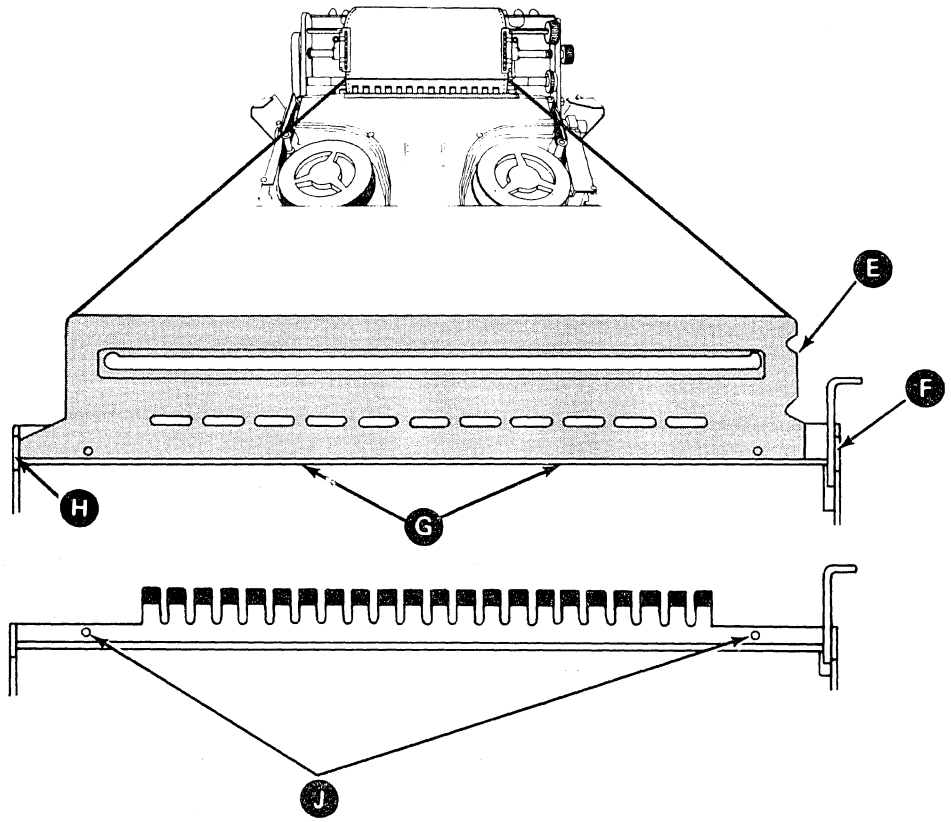

Chapter 5. Operating Procedures

Power-off to Online	5-3
Offline to Online	5-4
Changing Forms	5-5
Replenishing Forms	5-6
Selecting a New Page	5-7
Spacing Forms	5-7
Displaying Density	5-8
Changing Density	5-8
Requesting Host Attention	5-9
Changing Ribbon	5-9
Changing the Printer's Address	5-10
Using Test	5-10
Using Buffer Print	5-13
Recognizing Printer Status	5-15

This chapter gives you detailed procedures for operating the printer. Unless otherwise stated, the printer power is assumed to be on for these procedures.

This chapter also contains a list of the status indicators for each possible status to help you quickly recognize printer status. If the status indicates a problem, the chart refers you to Chapter 6 to solve the problem.

For the printer to be ready to operate, you must ensure that:

- It has been set up as described in *IBM 5225 Printer, Models 1, 2, 3, and 4, Setup Instructions*, GA34-0085.
- The ribbon is installed as explained in Chapter 4 of this guide.
- The appropriate forms for the next printing job are loaded and adjusted as explained in Chapter 3.

Warning: If you observe smoke, excessive heat, or an unusual odor coming from the printer, turn off the printer power immediately. Unplug the power cord, keep the printer's doors and cover closed, and request service.

Power-Off to Online

Follow these steps to go from power-off to online:

Attention and Ready lights:  Off  On

Step 1

Place the Mode Switch in the Online position.

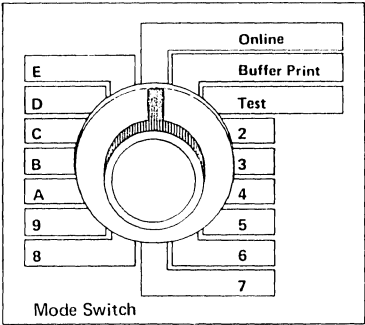

Mode Switch

Step 2

Switch on the printer power.

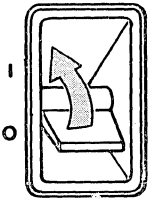

Step 3

Observe the status indicators. The automatic test is completed when the status indicators have sequenced to the last one shown (approximately 30 seconds).

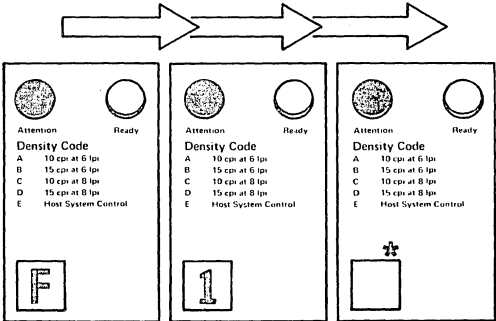

*Display blank, C, or D

Step 4

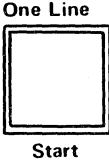

Press the Start key. (The Ready light is on and the Attention light is off; the printer is online and ready).



Start

Offline to Online

Follow these steps to change the printer from offline to online:

Attention and Ready lights:  Off  On

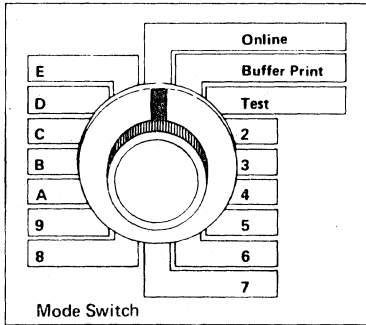
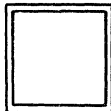
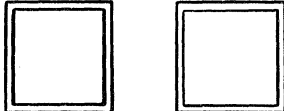
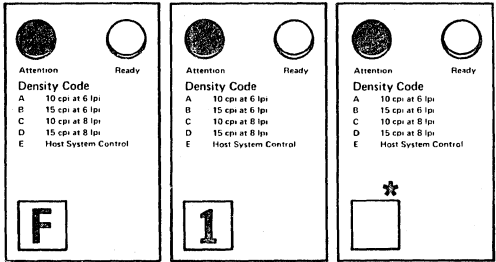
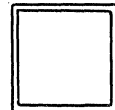
<p>Step 1</p> <p>Place the Mode Switch in the Online position.</p>	 <p>Mode Switch</p>
<p>Step 2</p> <p>Press the Stop Reset key.</p>	 <p>Stop Reset</p>
<p>Step 3</p> <p>Press and hold the 2nd Mode key, and then press the Cancel key.</p>	 <p>2nd Mode Cancel</p> <p>New Page</p>
<p>Step 4</p> <p>Observe the status indicators. The automatic test is complete when the status indicators have sequenced to the last one shown approximately 30 seconds).</p> <p>*Display blank, C, or D</p>	
<p>Step 5</p> <p>Press the Start key. (The Ready light is on and the Attention light is off; the printer is online and ready).</p>	 <p>One Line</p> <p>Start</p>

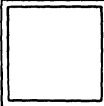
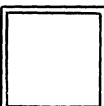

Changing Forms

Follow these steps to change forms:

<p>Step 1</p> <p>Press the Stop Reset key.</p>	 <p>Stop Reset</p>
<p>Step 2</p> <p>Unload the forms (if necessary, see “Unloading Forms” in Chapter 2).</p>	
<p>Step 3</p> <p>Load the new forms (if necessary, see “Loading Forms” in Chapter 3).</p>	
<p>Step 4</p> <p>Adjust the thickness control for the correct setting (if necessary, see “C. Adjusting the Thickness Control” in Chapter 3).</p>	
<p>Step 5</p> <p>Press the Start key.</p>	<p>One Line</p>  <p>Start</p>

Replenishing Forms

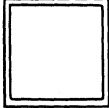
Follow these steps to replenish forms when the printer has run out of forms:

<p>Step 1</p> <p>Press the Stop Reset key.</p>	 <p>Stop Reset</p>
<p>Step 2</p> <p>If "E" clears, press the Start key.</p>	<p>One Line</p>  <p>Start</p>
<p>Step 3</p> <p>Repeat Steps 1 and 2 until "E" will not clear. (This enables you to print to the end of the page.)</p>	
<p>Step 4</p> <p>Load the Forms (if necessary, see "Loading Forms" in Chapter 3).</p>	
<p>Step 5</p> <p>Adjust or check the thickness control for the correct setting (if necessary, see "C. Adjusting the Thickness Control" in Chapter 3).</p>	
<p>Step 6</p> <p>Press the Start key.</p>	<p>One Line</p>  <p>Start</p>

Selecting a New Page

You can select a new page of the forms if the printer is online and not ready.

Follow these steps to select a new page:

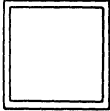
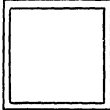
<p>Step 1</p> <p>Press the Stop Reset key.</p>	 Stop Reset
<p>Step 2</p> <p>Press the New Page key. (If the forms move only one line, the printer has not received a <i>vertical format command.</i>)</p>	<p>Cancel</p>  New Page

Spacing the Forms

Follow these steps to space the forms one line:

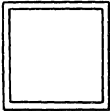
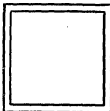
<p>Step 1</p> <p>Press the Stop Reset key.</p>	 Stop Reset
<p>Step 2</p> <p>Press the Space key. (The forms move one additional line each time you press the Space key.)</p>	 Space

Displaying Density

Follow these steps to display the printer's current density code:

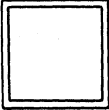
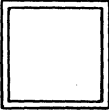
<p>Step 1</p> <p>Press the Stop Reset key.</p>	 <p>Stop Reset</p>
<p>Step 2</p> <p>Press the Display key. The printer's current density code is displayed as long as you hold the key. Code E is displayed only if the printer is online, not ready, and the host has selected a special density.</p>	 <p>Density Display</p>

Changing Density

Follow these steps to change the density:

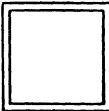
<p>Step 1</p> <p>Press and hold the 2nd Mode key.</p>	 <p>2nd Mode</p>
<p>Step 2</p> <p>Press the Density key. Each time you press the Density key, the display changes to a new code (A, B, C, D, or E). Release the 2nd Mode key.</p> <p>Note: When the printer is online and not ready, and you select code E, the code previously chosen by the host system is set. If the host system has not made a choice, code A is set.</p>	 <p>Density Display</p>

Requesting Host Attention

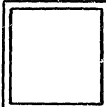
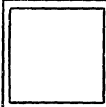

You can have your printer request the host's attention when the printer is online and ready. How the host handles the request varies depending on host programming.

Follow these steps to make a request to the host:

<p>Step 1</p> <p>Press and hold the 2nd Mode key.</p>	<p>2nd Mode</p> 
<p>Step 2</p> <p>Press the Cancel key.</p>	<p>Cancel</p>  <p>New Page</p>
<p>Step 3</p> <p>Release both the 2nd Mode and the Cancel keys.</p>	

Changing Ribbon

Follow these steps to change the ribbon:

<p>Step 1</p> <p>Press the Stop Reset key.</p>	 <p>Stop Reset</p>
<p>Step 2</p> <p>Change the ribbon, if necessary, see "Changing the Ribbon" in Chapter 4).</p>	
<p>Step 3</p> <p>Press the Start key.</p>	<p>One Line</p>  <p>Start</p>

Changing the Printer's Address

The printer's address is set when the printer is set up. If you need to check or change the printer's address, follow these steps:

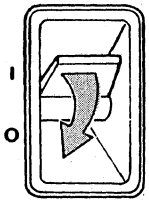
<p>Step 1</p> <p>Switch off the printer power.</p>	
<p>Step 2</p> <p>Refer to "Address Switches" in Chapter 2.</p>	

Note: Changing the address switches at your printer can cause problems with other devices connected to the same data cable. Before changing the address switches, inform the host system operator.

Using Test

Test generates a page of printed data while the printer is offline. You can use the page of test data for checking the print quality.

Before running Test, load the printer with single-part forms that are at least 375 millimeters (14.8 inches) wide. Ensure that the thickness control is adjusted for single-part forms (see "C. Adjusting the Thickness Control" in Chapter 3).

Follow these steps to run the Test:

Attention and Ready lights: Off On

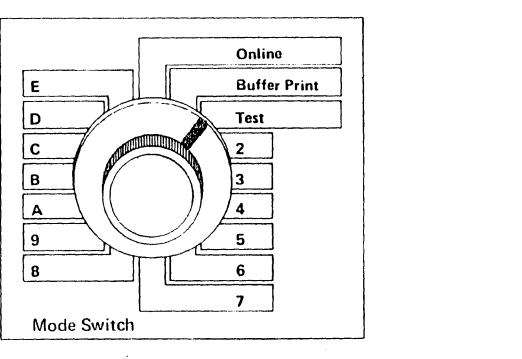
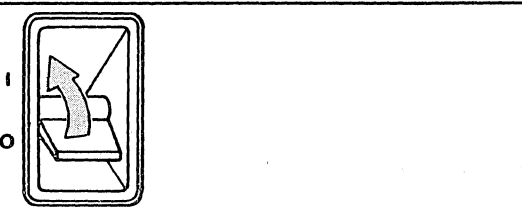
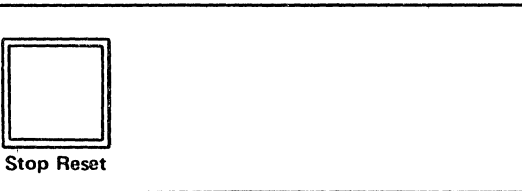
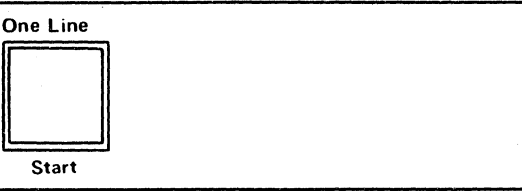
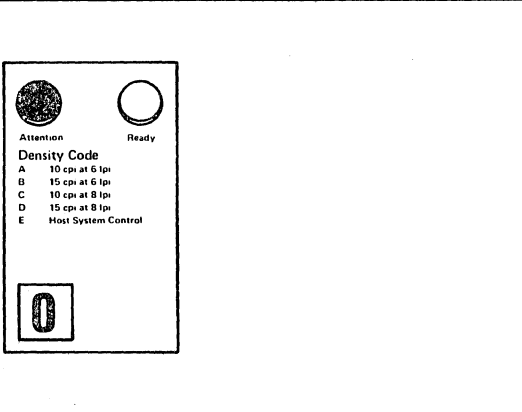
<p>Step 1</p> <p>Place the Mode Switch in the Test position.</p>													
<p>Step 2</p> <p>If the printer power is not on, switch it on and wait until the automatic test is completed (approximately 30 seconds).</p>													
<p>Step 3</p> <p>Press the Stop Reset key.</p>													
<p>Step 4</p> <p>Press the Start key.</p>													
<p>Step 5</p> <p>Observe the status indicator. (Test is completed when 0 appears. To run test again, press the Start key.)</p>	 <table border="1"><thead><tr><th>Density Code</th><th>Settings</th></tr></thead><tbody><tr><td>A</td><td>10 cpi at 6 lpi</td></tr><tr><td>B</td><td>15 cpi at 6 lpi</td></tr><tr><td>C</td><td>10 cpi at 8 lpi</td></tr><tr><td>D</td><td>15 cpi at 8 lpi</td></tr><tr><td>E</td><td>Host System Control</td></tr></tbody></table>	Density Code	Settings	A	10 cpi at 6 lpi	B	15 cpi at 6 lpi	C	10 cpi at 8 lpi	D	15 cpi at 8 lpi	E	Host System Control
Density Code	Settings												
A	10 cpi at 6 lpi												
B	15 cpi at 6 lpi												
C	10 cpi at 8 lpi												
D	15 cpi at 8 lpi												
E	Host System Control												

An example of a page of test data is shown on the next page.

Using Buffer Print

Buffer Print is used by system programmers and service personnel during program testing and troubleshooting.

Before operating the printer in Buffer Print, ensure that it is loaded with forms that are at least 375 millimeters (14.8 inches) wide.

Follow these steps to operate Buffer Print:

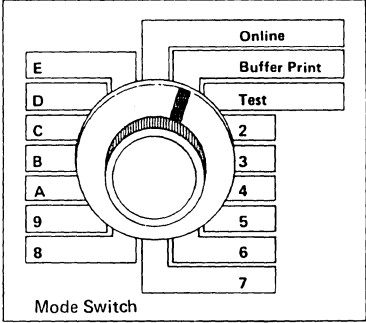
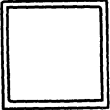
<p>Step 1</p> <p>Place the Mode Switch in the Buffer Print position.</p>	 <p>The diagram shows a circular mode switch with a pointer. To its left are labels E, D, C, B, A, 9, and 8. To its right are labels Online, Buffer Print, and Test, followed by numbered buttons 2, 3, 4, 5, 6, and 7. The pointer is positioned between Buffer Print and Test.</p>
<p>Step 2</p> <p>Press the Start key. Printing starts when data is received from the host.</p>	<p>One Line</p>  <p>Start</p>

An example of Buffer Print is shown on the next page.

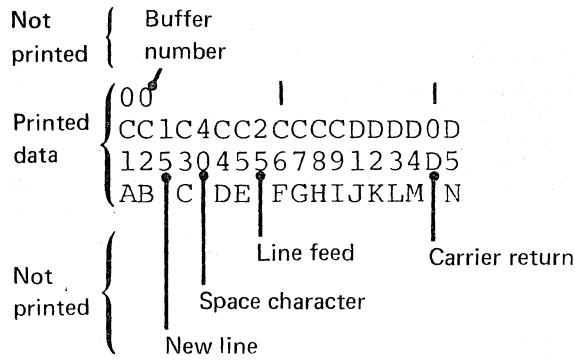

In the example, one line of data prints as four lines.

The second digit in the first line of data identifies the print buffer used.

To aid counting and identification, the characters are printed in groups of eight. A vertical bar is printed above the character which starts the next group of eight.

The characters represented by the codes are printed below the codes, on the fourth line. Formatting commands are not executed, but are printed as data.

During normal printing, when the formatting commands are executed, the buffer print example would print as:

```

AB
C DE
N FGHIJKLM

```

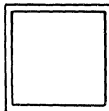
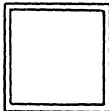

Follow these steps to change the printer from Buffer Print to normal print. Be sure the forms for the next printing job are loaded.

<p>Step 4</p> <p>Place the Mode switch in the Online position.</p>	
<p>Step 5</p> <p>Press the Stop Reset key.</p>	 <p>Stop Reset</p>
<p>Step 6</p> <p>Press the Start key (the printer is online and ready).</p>	<p>One Line</p>  <p>Start</p>

Recognizing Printer Status

You can recognize the printer's current status by observing the status indicators: the Display, Ready light, and Attention light. In addition to the status indicators, the audible alarm beeps during some status conditions.

The following charts show you all the possible printer status conditions:

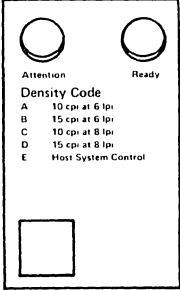
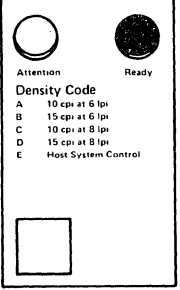
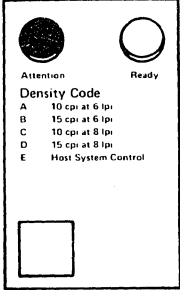

Attention and Ready lights:  Off  On

<i>Status indicators</i>	<i>Printer status</i>	<i>Comments</i>
	The printer's power is off.	To switch on the printer Power, refer to "Power-Off to Online" in this chapter.
	The printer is online and ready.	Printing starts when data is received.
	The printer is online and not ready.	To make the printer ready, press the Start key.

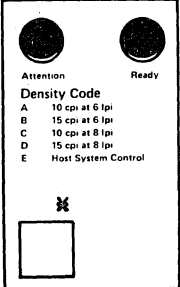
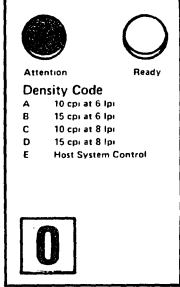
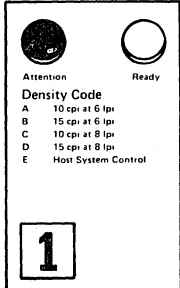
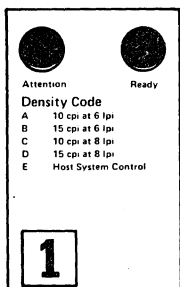

Attention and Ready lights:  Off  On

<i>Status indicators</i>	<i>Printer status</i>	<i>Comments</i>
 <p>Attention Ready</p> <p>Density Code</p> <p>A 10 cpi at 6 lpi B 15 cpi at 6 lpi C 10 cpi at 8 lpi D 15 cpi at 8 lpi E Host System Control</p> <p>8</p>	<p>A service test is running.</p>	<p>Go to "Problem Recovery Procedure" in Chapter 6.</p>
 <p>Attention Ready</p> <p>Density Code</p> <p>A 10 cpi at 6 lpi B 15 cpi at 6 lpi C 10 cpi at 8 lpi D 15 cpi at 8 lpi E Host System Control</p> <p>0</p>	<p>The printer is offline.</p>	<p>To place the printer online, see "Offline to Online" in this chapter.</p>
 <p>Attention Ready</p> <p>Density Code</p> <p>A 10 cpi at 6 lpi B 15 cpi at 6 lpi C 10 cpi at 8 lpi D 15 cpi at 8 lpi E Host System Control</p> <p>1</p>	<p>The printer has an electronic problem.</p>	<p>Go to "Problem Recovery Procedure" in Chapter 6.</p>
 <p>Attention Ready</p> <p>Density Code</p> <p>A 10 cpi at 6 lpi B 15 cpi at 6 lpi C 10 cpi at 8 lpi D 15 cpi at 8 lpi E Host System Control</p> <p>1</p>	<p>Test is running.</p>	<p>The printer's status changes when the Test is completed; observe the status indicators.</p>

* Any code other than 1.

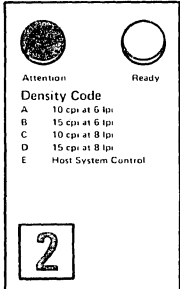
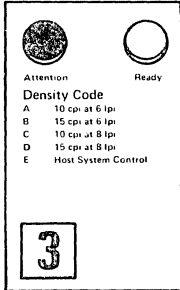
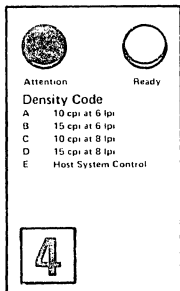
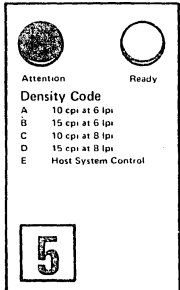





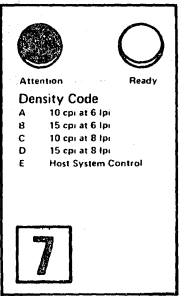
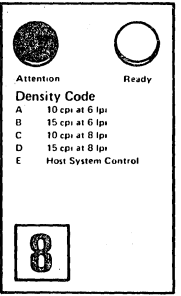
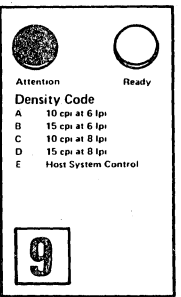
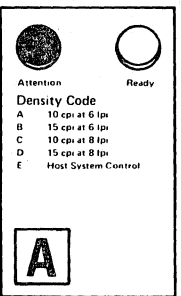

Attention and Ready lights:  Off  On

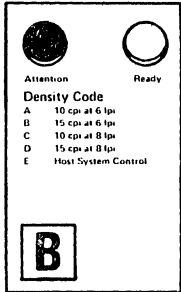

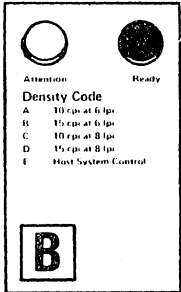
<i>Status indicators</i>	<i>Printer status</i>	<i>Comments</i>
	<p>The printer's address switches are set to 7 (an invalid address) or a printer problem exists.</p>	<p>Go to "Problem Recovery Procedure" in Chapter 6.</p>
	<p>The printer has either a mechanical or an electronic problem.</p>	<p>Go to "Problem Recovery Procedure" in Chapter 6.</p>
	<p>The printer has either a mechanical or an electronic problem, or a forms jam.</p>	<p>Go to "Problem Recovery Procedure" in Chapter 6.</p>
	<p>The host is requesting your attention.</p>	<p>Perform the action requested by the host; then, press the Stop Reset key and observe the status indicators.</p>

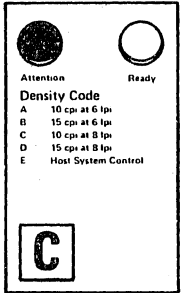

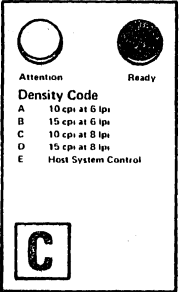



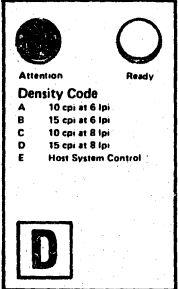

Attention and Ready lights:  Off  On

<i>Status indicators</i>	<i>Printer status</i>	<i>Comments</i>
 <p>Attention Ready</p> <p>Density Code</p> <p>A 10 cpi at 6 lpi B 15 cpi at 6 lpi C 10 cpi at 8 lpi D 15 cpi at 8 lpi E Host System Control</p> <p style="text-align: center; border: 1px solid black; width: 30px; margin: 10px auto;">7</p>	<p>The printer's top cover or the forms feed is open.</p>	<p>Go to "Problem Recovery Procedure" in Chapter 6.</p>
 <p>Attention Ready</p> <p>Density Code</p> <p>A 10 cpi at 6 lpi B 15 cpi at 6 lpi C 10 cpi at 8 lpi D 15 cpi at 8 lpi E Host System Control</p> <p style="text-align: center; border: 1px solid black; width: 30px; margin: 10px auto;">8</p>	<p>The ribbon is jammed or broken, or the printer has either an electronic or a mechanical problem.</p>	<p>Go to "Problem Recovery Procedure" in Chapter 6.</p>
 <p>Attention Ready</p> <p>Density Code</p> <p>A 10 cpi at 6 lpi B 15 cpi at 6 lpi C 10 cpi at 8 lpi D 15 cpi at 8 lpi E Host System Control</p> <p style="text-align: center; border: 1px solid black; width: 30px; margin: 10px auto;">9</p>	<p>The host has sent a special code or an unprintable character to the printer (graphic check).</p>	<p>To change the status, press the Stop Reset key and observe the status indicators.</p>
 <p>Attention Ready</p> <p>Density Code</p> <p>A 10 cpi at 6 lpi B 15 cpi at 6 lpi C 10 cpi at 8 lpi D 15 cpi at 8 lpi E Host System Control</p> <p style="text-align: center; border: 1px solid black; width: 30px; margin: 10px auto;">A</p>	<p>The host has canceled part of the data to be printed (data cleared).</p>	<p>Press the Stop Reset key and observe the status indicators.</p>

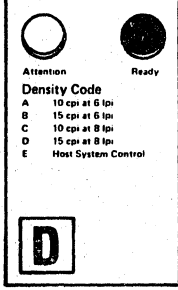
Attention and Ready lights:  Off  On

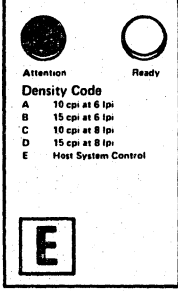
<i>Status indicators</i>	<i>Printer status</i>	<i>Comments</i>
 <p>Attention  Ready </p> <p>Density Code A 10 cpi at 6 lpi B 15 cpi at 6 lpi C 10 cpi at 8 lpi D 15 cpi at 8 lpi E Host System Control</p> <p>B</p>	<p>A data check error has been detected (line check).</p>	<p>Inform the host system operator that a "line check" occurred at your printer.</p> <p>This display flashes erratically if the data check errors are occurring irregularly.</p>
 <p>Attention  Ready </p> <p>Density Code A 10 cpi at 6 lpi B 15 cpi at 6 lpi C 10 cpi at 8 lpi D 15 cpi at 8 lpi E Host System Control</p> <p>B</p>	<p>A data check error has been detected (line check).</p>	<p>Inform the host system operator that a "line check" occurred at your printer.</p> <p>This display flashes erratically if the data check errors are occurring irregularly.</p>
 <p>Attention  Ready </p> <p>Density Code A 10 cpi at 6 lpi B 15 cpi at 6 lpi C 10 cpi at 8 lpi D 15 cpi at 8 lpi E Host System Control</p> <p>C</p>	<p>The printer is online, not ready, and the host is not communicating with it.</p>	<p>The display changes when the host starts communicating with the printer.</p> <p>This status could be caused by your printer's address switches being set incorrectly.</p> <p>See "Changing the Printer's Address" in this chapter.</p>
 <p>Attention  Ready </p> <p>Density Code A 10 cpi at 6 lpi B 15 cpi at 6 lpi C 10 cpi at 8 lpi D 15 cpi at 8 lpi E Host System Control</p> <p>C</p>	<p>The printer is online and ready, but the host is not communicating with it.</p>	<p>The display changes when the host starts communicating with your printer.</p> <p>This status could be caused by your printer's address switches being set incorrectly.</p> <p>See "Changing Address of Printer" in this chapter.</p>

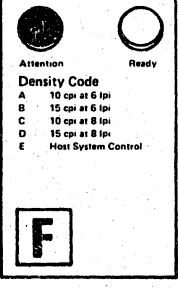
Attention and Ready lights:  Off  On

<i>Status indicators</i>	<i>Printer status</i>	<i>Comments</i>
 <p>Attention  Ready </p> <p>Density Code A 10 cpi at 6 lpi B 15 cpi at 6 lpi C 10 cpi at 8 lpi D 15 cpi at 8 lpi E Host System Control</p> <p>D</p>	<p>The printer is online, not ready, and the host is not sending a synchronization signal to your printer.</p>	<p>This is normal for some systems. The display changes when the host sends a line synchronization signal.</p>
 <p>Attention  Ready </p> <p>Density Code A 10 cpi at 6 lpi B 15 cpi at 6 lpi C 10 cpi at 8 lpi D 15 cpi at 8 lpi E Host System Control</p> <p>D</p>	<p>The printer is online and ready, but the host is not sending a synchronization signal to it.</p>	<p>This is normal for some systems. The display changes when the host sends a line synchronization signal.</p>
 <p>Attention  Ready </p> <p>Density Code A 10 cpi at 6 lpi B 15 cpi at 6 lpi C 10 cpi at 8 lpi D 15 cpi at 8 lpi E Host System Control</p> <p>E</p>	<p>The printer is out of forms or has a forms jam.</p>	<p>Open the front door of the printer and see if it is out of forms.</p> <ul style="list-style-type: none"> • If the printer is not out of forms, go to "Problem Recovery Procedures" in Chapter 6. • If the printer is out of forms, go to "Replenishing Forms" in this chapter.
 <p>Attention  Ready </p> <p>Density Code A 10 cpi at 6 lpi B 15 cpi at 6 lpi C 10 cpi at 8 lpi D 15 cpi at 8 lpi E Host System Control</p> <p>F</p>	<p>The printer's automatic test is running, or the printer has an electronic problem. (This is a normal indication for 10 seconds during the automatic test.)</p>	<p>If this status lasts longer than 30 seconds, go to "Problem Recovery Procedure" in Chapter 6.</p>

Chapter 6. Solving Printer Problems

Contents

Problem Recovery Procedure	6-2
Print Quality Problems	6-4
Service Request Checklist	6-5

If your printer develops a problem, use the procedures in this chapter to solve it.

“Recognizing Printer Status” in Chapter 5 lists all the possible printer status conditions. If the status indicates a problem that must be solved before printing can occur, you are referred to this chapter.

If you have an intermittent problem, you should run Test before switching off the printer power for the day (see “Using Test” in Chapter 5). The page of test data printed during Test may contain error information, and you should save it for service personnel.

If you have a problem that cannot be identified, record the information listed on the Service Request Checklist (see the last page of this chapter) and request service.

Problem Recovery Procedure

Follow these steps to recover from a printer problem:

<p>Step 1</p> <p>Press the Stop Reset key and retry the operation that was in progress when the problem occurred.</p>
<p>Step 2</p> <p>If the same status occurs, attempt to run Test and save the page of test data for service personnel. (See “Using Test” in Chapter 5.)</p>
<p>Step 3</p> <p>Open the front door and the top cover; then check the forms path for foreign objects, such as paper clips and rubber bands: remove any that you find.</p>
<p>Step 4</p> <p>Ensure that the thickness control is set correctly (see “C. Adjusting the Thickness Control” in Chapter 3).</p>
<p>Step 5</p> <p>If Test is being used (Mode Switch in Test), ensure that single-part forms are being used and that the thickness control is set for single-part forms.</p>
<p>Step 6</p> <p>Check for correct forms feeding into and through the printer (see Chapter 3 for forms loading information).</p>

Step 7

Ensure that the forms are not damaged (buckled, twisted, crumpled, or creased). Replace if necessary (see Chapter 3 for forms loading information).

Step 8

If you are using multipart forms, ensure that they are securely fastened on the edges and between pages, and that the tractor pins fit completely through all the margin holes.

Step 9

Check the ribbon and the ribbon path for a ribbon jam or damaged ribbon. Clear jams by turning the ribbon spools, or replacing the ribbon if necessary (see Chapter 4 for ribbon replacement information).

Step 10

Switch off the printer power.

Step 11

Ensure that the address switches are set correctly (see "Address Switches" in Chapter 2).

Step 12

Close the top cover and front door.

Step 13

Switch the printer on and wait 1 minute for the automatic test to run (the automatic test is complete when the display is blank, C, or D).

Step 14

Retry the operation that was in progress when the problem occurred.

Step 15

If the same problem exists, record the information listed on the Service Request Checklist and request service.

Print Quality Problems

A page of print should be clean, clear, horizontally and vertically aligned, and not printed off the page.

To test the print quality, see "Using Test" in Chapter 5.

Use the following chart to solve print quality problems. If you are unable to solve the problem, record the information listed on the Service Request Checklist and request service.

<i>Symptom</i>	<i>Problem</i>	<i>Solution</i>
Forms smudged or soiled by the ribbon	Thickness control set incorrectly Ribbon twisted Ribbon shield missing	Increase the thickness control setting (see Chapter 3). Install the ribbon correctly (see Chapter 4). Replace the ribbon shield (see Chapter 4).
Forms buckled, twisted, crumpled or creased	Incorrect forms feeding	See Chapter 3 for correct forms loading.
Printing is too light or incomplete	Thickness control set incorrectly Ribbon dry or damaged	Decrease the thickness control setting (see Chapter 3). Replace the ribbon (see Chapter 4).
Printing is too heavy	Thickness control set incorrectly	Increase the thickness control setting (see Chapter 3).
Printing off forms, outside of blanks or blocks	Incorrect line density Forms registration set incorrectly	Check the density code and change it, if necessary. See "Displaying and Changing the Density" in Chapter 5. See "D. Setting the First Print Position" and "E. Setting the First Print Line" in Chapter 3.

Service Request Checklist

If a service request becomes necessary, record these items and make them available to the service representative:

1. Printer location/number.
2. Date.
3. Time of day.
4. Your name.
5. When the problem occurred (while going from power-off to online, or during printing operations).
6. The state of the Attention indicator (on or off).
7. The state of the Ready indicator (on or off).
8. The displayed code (two characters).

Note: Press the Second Mode key to obtain the second character of the code.

9. A brief description of other symptoms, if any.
10. Remarks.

Index

A

A

- See status indicators
- access panel
 - See customer access panel
- address
 - changing the 5-10
 - defined 1-3
 - setting of 2-21
 - switches 2-21
- adjusting
 - stacking guides 3-17
 - thickness control 3-10
- adjustments
 - first character
 - See setting the first print position
 - forms
 - horizontally (see setting the first print position)
 - thickness control (see adjusting the thickness control)
 - vertically (see setting the first print line)
 - tractors 3-4, 3-9
- alarm, audible 2-20
- alignment
 - forms
 - horizontally (see setting the first print position)
 - vertically (see setting the first print line)
 - scale 3-15
- attention
 - host, requesting 5-20
 - light 2-6
- audible alarm 2-20
- automatic test 1-5, 3-3, 5-3, 5-4

B

B

- See status indicators
- blank
 - See status indicators
- buffer print
 - example 5-14
 - mode switch position 2-3
 - using 5-13
- buttons
 - See keys

C

C

- See status indicators
- cable-thru 2-20
- cable, data 1-3
- cancel key 2-12
- changing
 - address of printer 5-10
 - density 2-11, 5-8
 - forms 5-5
 - ribbon 4-2, 5-9
- character
 - See also status indicators
 - density 1-2
- checklist, service request 6-5
- checkout of printer
 - See test, using
- codes (see also status indicators)

- density 2-11, 5-8
- connectors, cable 2-20
- control panel
 - See operator panel
- copies
 - See forms
- customer access panel 1-3, 2-20

D

D

- See status indicators
- data
 - cables 1-3
 - cleared 5-18
- density
 - key
 - See key, density/display
 - changing 2-11, 5-8
 - character 1-2
 - codes 2-11, 5-8
 - displaying 5-8
 - lines 1-2
- display (see also status indicators)
 - codes 2-11
 - density 2-11, 5-8
 - key 2-6
- displaying density 5-8

E

E

- See status indicators
- errors
 - See status indicators
- extending life of ribbon 4-2

F

F

- See status indicators
- first print line
 - defined 1-5
 - setting 3-14
- first print position
 - define 1-5
 - setting 3-12
- forms
 - adjustment
 - first character (see setting the first print position)
 - first print line (see setting the first print line)
 - alignment scale 3-15
 - attention 5-20
 - copies 1-2
 - inserting 3-6
 - jam 5-20
 - length 1-3
 - loading 3-3
 - multipart 1-2, 2-18, 3-10
 - position of supply 3-6
 - replenishing 5-6
 - setting
 - first print line 3-14
 - first print position 3-12

smudging of 2-18, 3-10, 6-4
spacing 5-7
supply 3-4
thickness control, setting 3-10
types 1-2
unloading 3-19
widths 1-2

G

graphic check 5-18
guides, forms stacking 3-19

H

horizontal
forms adjustment
 See setting the first print position
perforation, defined 1-3
host
defined 1-4
system attention 5-17

I

indicator (see also light)
status
 See status indicators
installing
forms
 See loading forms
ribbon 4-3
ribbon shield 4-2

J

jams
forms 5-20, 5-23
ribbon 5-21, 6-3

K

key
cancel 2-12
display density 2-11
new page 2-12
one line 2-9
space 2-10
start 2-9
stop reset 2-10
2nd mode 2-8

L

light
attention 2-5
ready 2-6
line
check 5-19
density 1-2
sync 5-19, 5-20
loading forms 3-3

M

maintenance 1-6
margin feed holes 1-3
mode switch
buffer print position 2-3
online position 2-3
test position 2-3
2 through E positions 2-3

N

new page
key 2-13
selecting 5-7

O

offline
defined 2-3
status 5-16
testing
 See test, using
 to online 5-4
one line, print
 See one line key
online
defined 2-3
operating conditions 5-2
operator controls
 See specific control
operator's panel 2-4
operator's report
 See service request checklist
optional controls

P

page
selecting new 5-7
test data 5-12
panel
customer access 1-3, 2-20
operator's 2-4
paper
 See forms
perforation, horizontal 1-3
power switch 2-5
power-off to online 5-3
print
first line of
 See setting the first print position
first position of
 See setting the first print position
one line
 See one line key
one line key 2-9
quality 6-4
printer
address 1-4
 changing of 5-10
 setting of 2-21
models iii
preparing for operation 5-2
problems, solving 6-2
speeds 1-2
status, recognizing 5-15
printing speeds 1-2
problem

- codes
 - See status indicators
- solving 6-2
- procedures
 - changing forms 5-5
 - changing of printer address 5-10
 - changing ribbon 5-9
 - displaying and changing density 5-8
 - offline to online 5-4
 - power-off to online 5-3
 - problem solving 6-2
 - replenishing forms 5-6
 - selecting a new page 5-7
 - spacing forms 5-7
 - using buffer print 5-13
 - using test 5-10
- publications, related iii
- pushbuttons
 - See keys

Q

- quality of print 6-4

R

- ready light 2-6
- recognizing printer status 5-15
- recovery procedure 6-2
- related publications iii
- replacing the forms
 - See changing forms
- replacing the ribbon
 - See changing the ribbon
- request for service checklist 6-5
- reset
 - See key, stop reset
- ribbon
 - extending life of 4-2
 - jam 5-21, 6-3
 - signs of wear 4-2, 6-4
 - when to replace 4-2

S

- scale, forms alignment 3-15
- second mode key 2-8
- selecting density 2-11, 5-8
- service request checklist 6-5
- setting
 - first print line 3-14
 - first print position 3-12
 - thickness control
 - See adjusting the thickness control
- shield, ribbon
 - installing 4-5
 - removing 4-4
- smudging of forms 3-18, 3-10, 6-4
- solving printer problems 6-1
- space key 2-10
- speeds, printing 1-2
- stacking guides
- start key 2-11
- status indicators 1-5, 5-2, 5-15
- stop key
 - See stop reset key
- stop reset key 2-10
- switch
 - address 2-22

- mode 2-3
- power 2-5
- terminator 2-22
- sync, line 5-10, 5-20

T

- terminator switch 2-22
- test
 - automatic 1-5
 - page of data 5-12
 - using 5-10
- testing the printer
 - See test, using
- thickness
 - control 2-18
 - setting 3-11
- trouble report
 - See service request checklist
- troubleshooting
 - See solving printer problems

U

- unloading forms 3-12

V

- vertical
 - adjustment of forms
 - See setting the first print position
 - controls 2-16

0

- 0
 - See status indicators

1

- 1
 - See status indicators

2

- 2
 - See status indicators
- 2nd mode key 2-8

3

- 3
 - See status indicators

4

- 4
 - See status indicators

5

- 5
 - See status indicators

7

7 See status indicators

8

8 See status indicators

9

9 See status indicators

READER'S COMMENT FORM

GA34-0054-2

IBM 5225 Printer Models 1, 2, 3, and 4 Operator's Guide

Your comments assist us in improving the usefulness of our publications; they are an important part of the input used in preparing updates to the publications. IBM may use and distribute any of the information you supply in any way it believes appropriate without incurring any obligation whatever. You may, of course, continue to use the information you supply.

Please do not use this form for technical questions about the system or for requests for additional publications; this only delays the response. Instead, direct your inquiries or requests to your IBM representative or the IBM branch office serving your locality.

Corrections or clarifications needed:

Page	Comment
------	---------

Cut or Fold Along Line

Please indicate your name and address in the space below if you wish a reply.

Thank you for your cooperation. No postage stamp necessary if mailed in the U.S.A.
(Elsewhere, an IBM office or representative will be happy to forward your comments.)

Reader's Comment Form

Cut Along Line

Fold and tape

Please Do Not Staple

Fold and tape



NO POSTAGE
NECESSARY
IF MAILED
IN THE
UNITED STATES

BUSINESS REPLY MAIL

FIRST CLASS PERMIT NO. 40 ARMONK, NEW YORK

POSTAGE WILL BE PAID BY ADDRESSEE

IBM Corporation
Information Development, Dept 27T
P.O. Box 1328
Boca Raton, Florida 33432

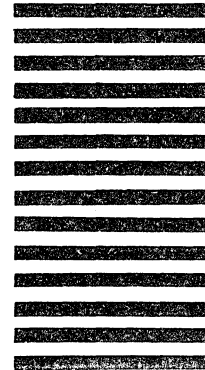

Fold and tape

Please Do Not Staple

Fold and tape

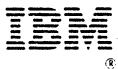

International Business Machines Corporation



International Business Machines Corporation