



Expression

MRI Patient Monitoring System

Model 865214



EXPRESS SERVICE MANUAL



989803162701 Rev. D

Proprietary Information

This document contains proprietary information, which is protected by copyright.

Manufacturer

Invivo Corporation
12501 Research Parkway
Orlando, FL 32826
(407) 275-3220
(800) 331-3220
www.invivocorp.com

Warranty

The information contained in this document is subject to change without notice. Invivo Corporation makes no warranty of any kind with regard to this material, including, but not limited to, the implied warranties or merchantability and fitness for a particular purpose. Invivo Corporation shall not be liable for errors contained herein or for incidental or consequential damages in connection with the furnishing, performance, or use of this material.

Limits of Liability

Invivo has taken care to ensure the accuracy of this document. However, Invivo assumes no liability for errors or omissions and reserves the right to make changes without further notice to any products herein to improve reliability, function, or design. Invivo may make improvements or changes in the product(s) or program(s) described in this document at any time.

Printing History

New revisions of this document will incorporate all material updated since the previous revision. Update packages may be issued between revisions and contain replacement and additional pages to be merged by a revision date at the bottom of the page. The documentation part number (P/N) and revision indicate the current edition.

P/N 989803162701 Rev. D

Copyright © 2010, Invivo Corporation

All rights reserved. Printed in U.S.A

Contents

1	Introduction	1
1.1	About this Manual	1
1.2	Text Conventions	1
2	Unpacking the System	3
3	System Overview	5
3.1	Cart Configuration.....	5
3.2	Patient Management Configuration	5
3.2.1	Battery Operation: Cart, PMC, and DCU.....	6
3.2.1.1	Installation and Removal	7
3.2.2	Battery Operation: WECG and WSpO2 Modules.....	8
3.2.2.1	Installation and Removal	9
3.2.3	Safe Battery Use.....	9
3.2.4	Battery Charging Instructions.....	10
3.2.5	Battery Disposal Instructions	10
3.2.5.1	Guidelines in Europe.....	11
3.2.5.2	Guidelines in the United States	11
4	System Installation	13
4.1	Power Supply	13
4.1.1	Part Number 989803169201.....	13
4.1.2	Part Number 989803168201.....	15
4.2	Cart Configuration.....	16
4.3	Patient Management Configuration (PMC).....	17
4.4	Display Control Unit (DCU)	18
4.4.1	Installed on the Cart	18
4.4.2	Stand Alone Operation.....	19
4.5	Additional Installation Options	21

5	System Power-Up	23
5.1	Removing AC Mains Power	23
6	Test and Inspection	25
6.1	When to Test.....	25
6.2	Test and Inspection Matrix Checklist.....	25
6.3	Performance Assurance Test Checklist.....	26
6.4	Recommended Frequency of Testing	27
6.5	Test Process Description	28
6.5.1	Test Equipment Requirements	28
6.5.2	Initial AC Power-Up.....	28
6.5.2.1	ETCO2 Option Only	28
6.5.3	Operational Tests.....	28
6.5.3.1	System Communication Verification	29
6.5.3.2	WECG Communication.....	29
6.5.3.3	WSpO2 Communication.....	30
6.5.3.4	NIBP Verification	31
6.5.3.4.1	Pneumatic Leak Test High (1 st row)	31
6.5.3.4.2	Pneumatic Leak Test Low (2 nd row)	31
6.5.3.4.3	NIBP Offset Verification	31
6.5.3.4.4	Calibration Accuracy Check.....	32
6.5.3.4.5	Overpressure Adult.....	32
6.5.3.4.6	Overpressure Neonatal.....	33
6.5.3.4.7	Adult Cuff Test	33
6.5.3.4.8	Adult Dead Man Cuff	34
6.5.3.4.9	Neo-Natal BP.....	34
6.5.3.4.10	Neo-Natal Dead Man Cuff.....	35
6.5.3.4.11	Leak Time Out, Adult	35
6.5.3.4.12	Leak Time Out, Neo-Natal.....	35
6.5.3.4.13	Calibrate Error.....	36









6.5.3.5	Invasive Pressure Verification.....	36
6.5.3.6	Agents Verification.....	37
6.5.3.6.1	Agents Flow Test.....	37
6.5.3.6.2	O2 Sensor Verification	39
6.5.3.7	ETCO2 Flow Test Verification.....	39
6.5.3.8	Respiration Verification	40
6.5.3.9	Temperature Verification	40
6.5.4	Electrical Safety Testing	40
7	Removal and Replacement	41
7.1	The Cart WPU.....	41
7.1.1	WPU Removal from the Cart.....	41
7.1.2	WPU Replacement into the Cart.....	45
7.1.3	Exchange Network Setup.....	48
7.1.3.1	Network Channel Options.....	48
7.1.3.2	Exchange Parameter Disabling	49
7.2	The PMC WPU	49
7.2.1	WPU Removal from the PMC.....	49
7.2.2	WPU Replacement into the PMC.....	54
7.2.3	Exchange Network Setup.....	60
7.2.3.1	Network Channel Options.....	60
7.2.3.2	Exchange Parameter Disabling	61
8	Service Parts	63
8.1	Non-Exchange Service Parts	63
8.2	Exchange Service Parts	65
8.3	System Preventative Maintenance Parts.....	66
8.4	Service Numbers and Replacement/Exchange Parts.....	66
9	List of Symbols.....	69

1 INTRODUCTION

This Express Service manual is intended for use by qualified service personnel for the repair and maintenance of the *Expression* MRI Patient Monitoring System. This manual contains information regarding the installation, intended use, accessories, and troubleshooting of a fully equipped *Expression* MRI Patient Monitoring System. The terms “Cart” and “Patient Management Configuration (PMC)” are used throughout this document to refer to the configurations of the *Expression* MRI Patient Monitoring System. Specific differences between available configurations, where applicable, are noted in the text. Some information in this manual may depict monitoring features that your system does not contain. For information on features and enhancements that are not included in your system, contact Invivo Corporation at (800) 331-3220 or your Invivo sales representative. For additional information about your accessories, please consult the documentation that accompanied the accessory.

1.1 About this Manual

This manual contains the following sections:

-  Section 1: Introduction, page 1.
-  Section 2: Unpacking the System, pages 3–4.
-  Section 3: System Overview, pages 5–11.
-  Section 4: System Installation, pages 13–21.
-  Section 5: System Power-Up, page 23.
-  Section 6: Test and Inspection, pages 25–40.
-  Section 7: Removal and Replacement, pages 41–61.
-  Section 8: Service Parts, pages 63–67.
-  Section 9: List of Symbols, pages 69–72.

1.2 Text Conventions

The manual uses the following conventions for Warnings, Cautions, and Notes:

WARNING: A Warning calls attention to a condition or possible situation that could cause injury to the user and/or patient.

CAUTION: A Caution calls attention to a condition or possible situation that could damage or destroy the product or the user’s work.

 **Note:** A Note calls attention to notable details or to conventions used within this text.

2 UNPACKING THE SYSTEM

This section provides instructions regarding the unpacking and inspection of the *Expression* MRI Patient Monitoring System. Remove the system components from the shipping container(s). Verify the presence of all ordered items against the included packing list and purchase request. Carefully examine all components for any damage that may have occurred during shipment. Save the packing materials and related shipping documents, as these will be required to process a claim with the carrier if damage during shipment occurred. To resolve any issues or concerns with your order or product, or to report shipping damage, contact Invivo Customer Service; see Warranty.

CAUTION: The *Expression* MRI Patient Monitoring System must be used and stored according to the environmental specifications in Appendix A of the Instructions for Use (IFU) manual. Failure to follow these specifications can affect the accuracy of the *Expression* MRI Patient Monitoring System.

1. Open the 4 Snaps that secure the lid to the crate. Remove the lid and Foam Insert C from the crate.

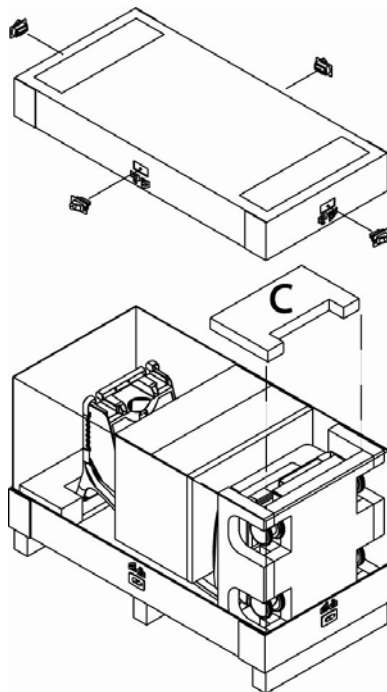

2. Remove the Accessories Box and Foam Insert B.

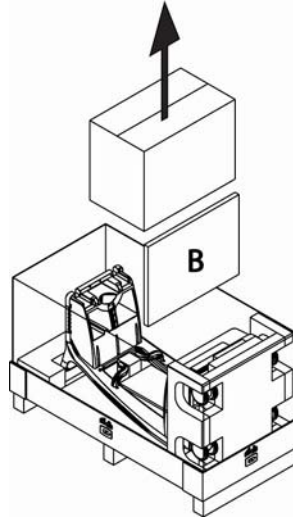

3. Remove Foam Insert A and unlock the wheels of the Cart.

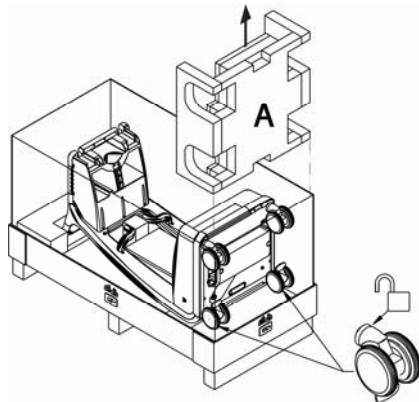

4. Carefully raise the crate and then roll out the Cart.

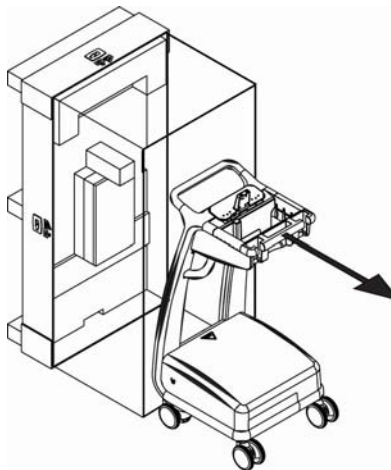

3 SYSTEM OVERVIEW

Depending on the system, the *Expression* MRI Patient Monitor has several possible configurations.

3.1 Cart Configuration

The Cart configuration consists of the following primary components:

- One Cart, including the Wireless Processing Unit (WPU)
- One Display Control Unit (DCU)
- One Wireless ECG (WECG) Module
- One Wireless WSpO₂ (WSpO₂) Module
- Two Wireless Module Batteries
- Four Cart / DCU Batteries
- One DCU Power Converter Kit
- One Power Supply

The DCU may be docked on the Cart or located remotely; see the *Expression* IFU for details. When docked on the Cart and with the Cart connected to AC mains power, the DCU and Cart batteries are charged through the battery charger contained within the Cart. For added flexibility, the system can be configured with two additional DCUs. The additional DCUs can be located in the MR system room, MR control room, or MR holding area. Refer to the *Expression* IFU for warnings, cautions, and instructions regarding the DCU.

3.2 Patient Management Configuration

The Patient Management Configuration (PMC) consists of the following primary components:

- One Patient Management Configuration (including the WPU)
- One DCU
- One WECG module
- One WSpO₂ module
- Two Wireless Module Batteries
- Four PMC / DCU Batteries
- One DCU Power Converter Kit
- Power Supply(s): one with dual DC Outputs, or two with single DC Outputs

Several options are available for the placement of the PMC, including:

- Horizontal mounting to a patient examination table;
- Vertical mounting to a patient examination table;
- Mounting to an anesthesia cart; and,
- Mounting to a stationary surface.

With the PMC connected to AC mains power, the batteries within the PMC are charged through the internal battery charger. The accompanying DCU can be located in the MR system room, MR control room, or MR holding area. For added flexibility, the system can also be configured with two

additional DCUs. Refer to the *Expression* IFU manual for warnings, cautions, and instructions regarding the DCU.

3.2.1 Battery Operation: Cart, PMC, and DCU

The Cart, PMC, and DCU batteries are interchangeable. Depending upon your equipment type, the number and location of the batteries (P/N 989803169491) will differ:

- The Cart has two batteries located on the underside of the unit.



- The DCU has two batteries located on the left and right sides of the unit.



- The PMC has two batteries located beneath the latched top cover on the unit.

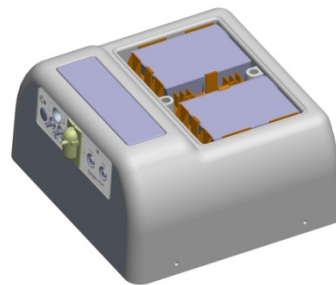

The lower portion of the DCU contains the System Status area, dedicated to displaying the battery and wireless communication status; see Section 6.5.3. (Refer to *Expression* IFU manual for a full explanation of the Battery Status Display.) Maximum operation time of the Cart, PMC, and DCU batteries is approximately 8 hours when anesthetic agents and CO₂ are turned off, and NIBP, ECG, and SpO₂ parameters are running at 5-minute intervals. Battery operation time will be reduced by up to 2 hours when performing certain operations such as anesthetic agents monitoring, printing charts and trends, or running short automatic NIBP cycle times.

When the AC mains power is interrupted and batteries in the Cart, PMC, and DCU are inserted, the *Expression* automatically switches to internal batteries.

Note: To prevent unintentional power interruption, *Invivo* recommends keeping the batteries inserted in the equipment, even when operating under AC mains power.

3.2.1.1 Installation and Removal

WARNING: The batteries used within the Cart, PMC, and DCU contain some ferrous materials that are attracted to the MR magnetic field. **DO NOT** install or remove the batteries from the devices when these units are closer than the 1,000 Gauss (0.1 T) field line as measured from the center line of the MR bore. The batteries will be attracted to the magnetic field, possibly causing patient or user injury.

CAUTION: Never force a battery into the battery compartment; damage to the battery or the *Expression* MRI Patient Monitoring System will occur.

To install batteries into the Cart, PMC, and DCU, the batteries must be oriented properly to latch into place in the battery compartments, as the battery contours fit the device geometry. Slide the batteries into their respective compartments and they will automatically latch into place. If the battery does not latch automatically when fully inserted into the battery compartment, then the battery is not positioned properly. In this case, reorient the battery then retry installation.

To install batteries in the PMC, follow the steps below.

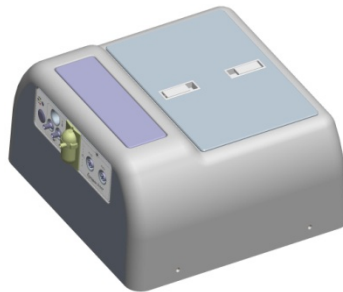

Step	Battery Installation – PMC
1.	Move the PMC away from the MR system, outside of the 1,000 Gauss (0.1T) field line (as measured from the center line of the MR bore), prior to installing batteries.
2.	Remove the Battery Compartment Cover by lifting the latches.
3.	Slide the batteries into their respective holder until seated (refer to the following figures).
4.	Install the Battery Compartment Cover.
5.	Assure that the Battery Compartment Cover is latched into place.

To remove batteries from the Cart and DCU, press the battery eject button on the device and the battery will partially eject for easy removal.

To remove batteries from the PMC, follow the steps below.

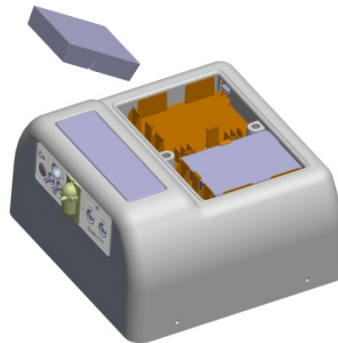

Step	Action
1.	Move the PMC away from the MR system, outside of the 1,000 Gauss (0.1T) field line (as measured from the center line of the MR bore), prior to removing batteries.
2.	Remove the Battery Compartment Cover by lifting the latches.
3.	Pull the latch holding the battery with one hand.
4.	Using your other hand, pull the battery out (from the side opposite the connector) of the PMC.

3.2.2 Battery Operation: WECG and WSpO2 Modules

The WSpO₂ and WECG modules have interchangeable batteries (P/N 9065). These batteries slide and latch into the battery slots in the WECG and WSpO₂ modules.



3.2.2.1 Installation and Removal

CAUTION: The 9065 Battery and wireless module should not be placed in the Field of View to minimize the chance of image artifact.

Note: *The WECG and WSpO₂ module batteries are non-magnetic and can be removed and replaced from the modules while in the MR magnetic field.*

To install batteries into the WSpO₂ and WECG modules, slide a battery into the battery slot in the module until the battery latches (on each side) into place.

To remove batteries from the WSpO₂ or WECG modules, simultaneously press the latches on both sides of the battery then slide the battery out of the module.

3.2.3 Safe Battery Use

The following warnings, cautions, and notes shall be observed to ensure the safety of operators and patients.

WARNING: Stop using any battery that exhibits abnormal heat, odor, color, deformation or is in an abnormal condition. If a battery is punctured or liquid leaks onto your skin or clothing, wash skin and clothing with fresh water immediately. If liquid leaks from a battery and gets into your eyes, do not rub your eyes. Wash eyes well with clean water and consult a doctor immediately.

CAUTION:

- If the battery terminals become dirty, wipe them with a clean dry cloth before use.
- Keep the battery terminals away from metal objects.

Note: *Batteries have life cycles. If the time that the battery is powering the equipment becomes much shorter than usual, the battery life is at an end. Remove a battery with an expired life cycle from the equipment immediately. Replace the battery with a new Invivo specified battery. Refer to Section 8 for part numbers.*

3.2.4 Battery Charging Instructions

Charge the batteries before use. When installing the system for the first time, all batteries must be charged at least 12 hours with AC power to the *Expression* turned off so that the batteries are fully charged and conditioned for operation.

The Cart, PMC, and DCU batteries are charged by integrated intelligent battery chargers. These intelligent charging devices automatically provide the appropriate profile needed to efficiently charge and condition the batteries. When the Cart, PMC, and DCU are plugged into AC power and turned off, the battery charger is functional and will automatically charge the batteries. When the Cart, PMC, and DCU are turned ON, they operate from AC power and charge the batteries simultaneously.

When the Cart, PMC, and DCU batteries are removed from the system, the user can determine battery capacity by pressing the battery's Power Level button then observing the LEDs. The LEDs indicate the battery capacity, in 20 percent increments, from 20 – 100 percent. Indications of battery capacity are also available via the DCU; see the *Expression* IFU manual. The minimum battery voltage value for normal operation is 14.8V.

The Wireless ECG and SpO₂ module batteries must be charged by the stand-alone Invivo battery charger (P/N 9023). Refer to the instructions and cautions provided with the battery charger for more information. Indications of battery capacity are also available via the DCU; see the *Expression* IFU manual. The minimum battery voltage value for normal operation is 3.4V.

3.2.5 Battery Disposal Instructions

The *Expression* MRI Patient Monitoring System uses lithium-polymer and lithium-ion batteries that are subject to strict disposal regulations for user and environmental safety.

- | |
|--|
| <p>CAUTION:</p> <ul style="list-style-type: none">▪ Never heat or throw the battery into a fire. Heating the battery will damage the safety circuitry, which can cause rupture or ignition of the battery.▪ Batteries must be stored in a dry place, at a temperature between 0°C to 40°C.▪ The <i>Expression</i> MRI Patient Monitoring System uses rechargeable batteries that contain hazardous material. These batteries must be recycled or disposed of properly. Refer to disposal guidelines listed below. Do not disassemble or incinerate the battery. |
|--|

3.2.5.1 Guidelines in Europe

The European Community (EC) has issued two directives regarding battery disposal: 91/157/EEC and 93/86/EEC. Each member country implements these independently. Thus, in each country the manufacturers, importers, and users are responsible for the proper disposal or recycling of batteries. Confirm proper disposal requirements with your healthcare facility or distributor.



3.2.5.2 Guidelines in the United States

The U.S. Federal Environmental Protection Agency (EPA) hazardous waste regulations, as conveyed by the Resources Conservation and Recovery Act (RCRA), neither specifically list nor exempt lithium batteries. The only metal of possible concern in the battery is the lithium metal that is not listed or characterized as a toxic hazardous waste. Significant amount of spent cells and batteries that are untreated and not fully discharged are considered as reactive hazardous waste. Thus, hazardous waste of spent cells and batteries can be disposed after they are first neutralized through an approved secondary treatment prior to disposal (as required by U.S. Land Ban Restriction of the Hazardous and Solid Waste Amendments of 1984). Disposal of spent batteries must be performed by authorized, professional disposal company, which has the knowledge in the requirements of the Federal, the State and the Local authorities regarding hazardous materials, transportation, and waste disposal. Confirm proper disposal requirements with your healthcare facility, distributor, and/or local EPA office.

4 SYSTEM INSTALLATION

This section provides instructions regarding the installation of the *Expression* MRI Patient Monitoring System. Observe the following warnings, cautions and notes when installing, setting up, and using the *Expression* MRI Patient Monitoring System.

- WARNING:**
- Do not use the *Expression* MRI Patient Monitoring System in the presence of flammable anesthetics.
 - Always verify proper communication of the *Expression* with the corresponding DCU prior to patient use.

- CAUTION:**
- Avoid the use of cellular phones or other radio-frequency transmitters in the proximity of an operating *Expression* MRI Patient Monitoring System.
 - Where the integrity of the external protective conductor in the installation or its arrangement is in doubt, the system shall be operated from batteries.

- Note:**
- Do not use two *Expression* MRI Patient Monitoring Systems in the same MR room, as this will lead to communication errors.
 - A minor but noticeable degradation in the Wireless ECG and Wireless SpO₂ radio communications will occur in the presence of high-powered radios.

4.1 Power Supply

Depending upon the equipped Power Supply, observe the following warnings, cautions, and notes when installing, setting up, and using the *Expression* MRI Patient Monitoring System.

4.1.1 Part Number 989803169201

WARNING: Ensure that the Power Supply (P/N 989803169201) remains 10 feet (3 meters) or more from the MR system. Mount the Power Supply to a horizontal surface using the pre-applied Velcro strips on the bottom of the supply.

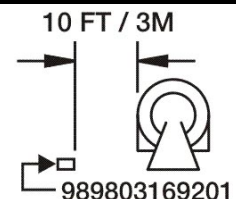

CAUTION: Avoid use of electrical extension cords or Multiple Portable Socket Outlets which may create a safety hazard by compromising the grounding integrity of the *Expression* MRI Patient Monitoring System.

Input / Output Configuration of Power Supply, P/N 989803169201:

AC Input:

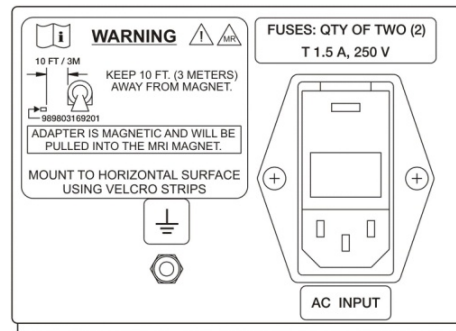

DC Output:

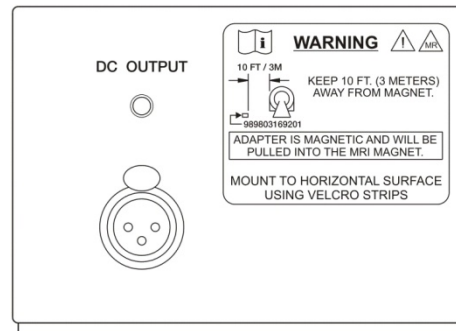

The ground terminal (as designated by the  symbol) on Power Supply P/N 989803169201 allows Invivo-authorized service personnel to connect a ground strap to prevent ESD discharge during servicing, and for testing leakage currents.

CAUTION: Performance of the *Expression* MRI Patient Monitoring System and any other devices within the room may be degraded if the ground terminal is used against Invivo's intended use, as listed above.

4.1.2 Part Number 989803168201

<p>WARNING: Ensure that the Power Supply (P/N 989803168201) remains 10 feet (3 meters) or more from the MR system, mounted to a horizontal surface using the pre-applied Velcro strips and/or secured to the floor (or another immovable surface) with fasteners through the unit's mounting flange holes, in order to prevent the Power Supply from being pulled into the MRI Magnet.</p>	<p>10 FT / 3M</p> <p>989803168201</p>
---	---------------------------------------

<p>CAUTION:</p>	<p>If longer distances are required, only use approved AC electrical extension cord, P/N 989803168221; avoid use of extension cords or multiple portable socket outlets, which may create a safety hazard by compromising the grounding integrity of the MRI Patient Monitoring System.</p>
------------------------	---

Input / Output Configuration of Power Supply, P/N 989803168201:

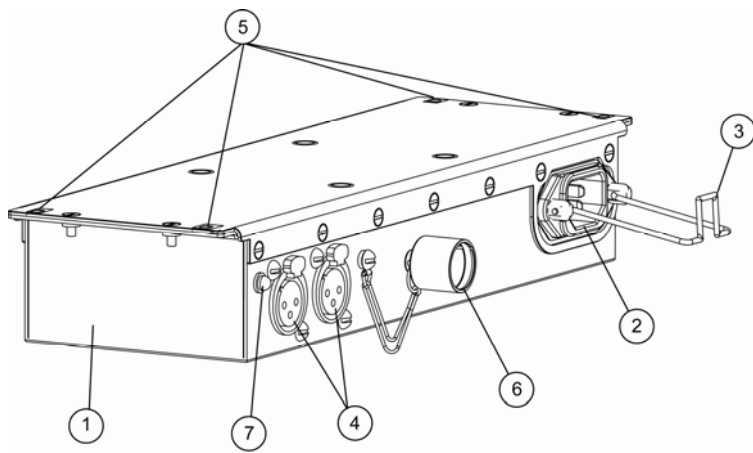

Item	Description
①	Power Supply 989803168201
②	AC Input Connector
③	Strain Relief
④	DC Output Connector (2)
⑤	Mounting Flange Holes (4)
⑥	Shield Cap
⑦	LED Indicator (Illuminated = Power ON)

<p>WARNING:</p>	<p>If using only one DC Output, cover the unused output with the Shield Cap in order to prevent noise artifacts from appearing on the MR image.</p>
------------------------	---

4.2 Cart Configuration

Observe the following warnings, cautions, notes, and instructions when installing, setting up, and using the Cart configuration for the *Expression* MRI Patient Monitoring System.







WARNING:

The *Expression* MRI Patient Monitoring System Cart may be used inside the MR system room in a location at or outside the 5,000 (5,000 or less) Gauss (0.5T) field line of the MR system, as measured from the center line of the MR bore. Failure to properly place the *Expression* and its accessories in the MR system room will result in system or accessory failure, and possible patient or user injury. Always secure the Cart's wheel locks when the unit is placed within the MR system room.







CAUTION:

- If the *Expression* MRI Patient Monitoring System Cart rolls to the face of the MR system due to magnetically induced pull force, DO NOT ATTEMPT TO DISLodge THE *EXPRESSION* BY PULLING FROM THE DOCKED DCU OR GUIDE HANDLE AT THE TOP OF THE SYSTEM. Dislodge the *Expression* by gently pulling from the base of the system at its lowest point. This will prevent the base of the unit from experiencing higher MR pull forces in the vertical direction.
- Field strength variations in a particular MR system room (which may be due to active shielding technology, manufacturer variability, future enhancements, etc) can make distinguishing the 5,000 Gauss level (as measured from the center line of the MR bore) difficult. These variations may require moving the Cart away from the MR system if system abnormalities or malfunctions are observed. Prior to clinical use, ensure that the allowable distance of the *Expression* components from the MR system is maintained for proper operation.



Complete the following actions to install the Cart configuration:

Step	Action
1.	Install the batteries into the Cart; see Section 3.2.1.
2.	Locate the Power Supply and attach the AC Power Cord to the AC Input of the Power Supply; see Section 4.1.
3.	Connect the male end of the 25 ft. DC power cable (P/N AC517B) to the DC Output of the Power Supply.
4.	Position the Power Supply in the MR system room near an approved AC outlet at a distance of at least 10 feet (3 meters) from the MR system.
5.	Plug the female end of the DC power cable into the Power Input of the Cart.
6.	Position the Cart within the parameters specified (in the warnings and cautions, above) and then lock the wheels.
7.	Plug the AC Power Cord into the AC outlet.

4.3 Patient Management Configuration (PMC)

Observe the following warnings and instructions when installing, setting up, and using the PMC for the *Expression* MRI Patient Monitoring System.



 WARNING:	<p>The Patient Management Configuration (PMC) may be used inside the MR system room at or outside the 2,000 Gauss (0.2T) field line as measured from the center line of the MR bore. Always ensure that no portion of the PMC is closer than 2,000 Gauss (0.2T) field line and that the PMC is securely fastened to the mounting surface. System failure or patient injury may result if the PMC is brought closer than 2,000 Gauss (0.2T) field line.</p>	
--	---	---

Complete the following actions to install the PMC:

Step	Action
1.	Mount the PMC.
2.	Install the batteries into the PMC; see Section 3.2.1
3.	Locate the Power Supply and attach the AC Power Cord to the AC Input on the Power Supply; see Section 4.1.
4.	Connect the male end of the 25 ft. DC power cable (P/N AC517B) to the DC Output on the Power Supply.
5.	Position the Power Supply in the MR system room near an approved AC outlet at a distance of at least 10 feet (3 meters) from the MR system; see the warnings and cautions in Section 4.1.
6.	Plug the female end of the DC power cable into the Power Input on the PMC.
7.	Plug the AC Power Cord into the AC outlet.

4.4 Display Control Unit (DCU)

The DCU may be used in the MR system room, MR control room, or in the MR holding area. Warnings and cautions must be observed to ensure safe use and system reliability. The DCU can be docked to the Cart or can operate independently under battery or AC mains power.

If the DCU must be located in the MR system room, it should be operated under battery power or docked to the Cart. If the DCU must be located in the MR system room *and* connected to AC mains, use the Power Supply P/N 989803169201 or P/N 989803168201. Additional power supplies may be purchased from your Invivo sales representative.

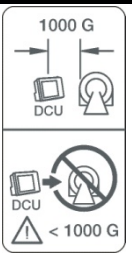

4.4.1 Installed on the Cart

 WARNING:	<p>The DCU contains some ferrous materials that are attracted to the MR magnetic field. DO NOT install or remove the DCU from the Cart when the <i>Expression</i> MRI Patient Monitoring System is closer than the 1,000 Gauss (0.1 T) field line as measured from the center line of the MR bore. The DCU will be attracted to the magnetic field, possibly causing patient or user injury.</p>	
--	--	---

Complete the following actions to install the DCU on the Cart:

Step	Action
1.	While holding the DCU handle, center the DCU over the Cart Mounting Shoe; see illustration below. <i>Note: Pressing the button on the back of the DCU is <u>not</u> necessary.</i>
2.	Carefully slide the DCU onto the Cart Mounting Shoe until the DCU latch snaps into place. NEVER force the DCU onto the Cart.

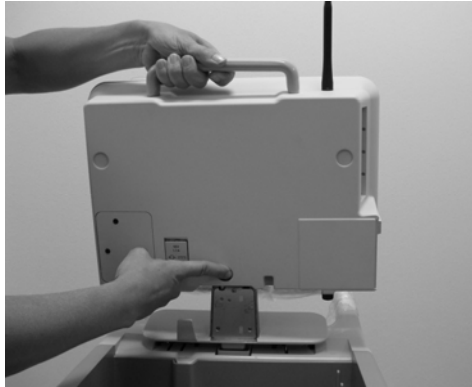

To remove the DCU from the Cart complete the following actions:

Step	Action
1.	Tilt the DCU all the way back.
2.	With one hand, press and hold the button on the back of the DCU; see illustration above.
3.	With your other hand, grasp the DCU handle and then lift upward (while continuing to press the button) until the DCU clears the Cart Mounting Shoe.
4.	Lift the DCU off the Cart.

4.4.2 Stand Alone Operation

Observe the following instructions to operate the DCU using AC power.

Step	Action
1.	Install batteries into the DCU; see Section 3.2.1.
2.	Locate the DCU Power Converter Kit. Attach the AC power cord to the AC input on the Power Converter (P/N 453563464761).
3.	Connect the male end of the 5 ft. DCU power cable (P/N 453564109681) to the DC output of the power converter.

Step	Action <i>(Continued)</i>
4.	Position the DCU and power converter in the MR control room or holding area, near an approved AC outlet, and then connect to that AC outlet.
5.	Plug the female end of the DCU power cable into the power input on the back of the DCU.
6.	Repeat the above steps for each additional DCU that will be used in the MR control room or holding area.



WARNING:

- **Do not use the DCU Power Converter Kit (P/N 453564123631) inside the MR system room. The device is magnetic and will be pulled into the MR system. Never take the DCU Power Converter Kit into the MR system room. The device is intended for use with the Display Control Unit only when used outside the MR system room.**
- **None of the interconnection ports on the back of the DCU (e.g. Communications, AUX I/O, USB, Keyboard, Gating or Video) are intended for direct patient connection. An electric shock hazard can exist if the patient is electrically connected to any of these connections.**



CAUTION:

- Do not dock the DCU to the Cart while the DCU is still connected to AC mains. Damage to the DCU or power cable may result.
- If the printer option is present in the DCU, it may be used in the MR system room at or outside the 1,000 Gauss (0.1T) field line (as measured from the center line of the MR bore) of the MR system. Do not move the DCU closer than the specified Gauss field line or damage to the printer (failure to operate) may result. If operation of the DCU is necessary in close proximity to the 1,000 Gauss (0.1T) field line, position the DCU so that the printer is on the opposite side of the gurney.
- If the printer option is not present, the DCU may be used at or outside the 5,000 Gauss (0.5T) field line as measured from the center line of the MR bore.



1000 G

DCU

< 1000 G

4.5 Additional Installation Options

Additional installation options (such as those listed below) may increase operator ease of use, as the *Expression* DCU, Cart, and PMC are configured with input/output ports that permit connections to external equipment:

- Connection to an external projector.
- Connection to an external monitor.
- Connection to facility information systems.

- | |
|--|
| <p>CAUTION:</p> <ul style="list-style-type: none">▪ When using the input/output connections on the back of the DCU, Cart, or PMC verify that the final installation complies with IEC/EN 60601-1-1, <i>General Requirements for the Safety of Medical Electrical Systems</i>, to assure operator and patient safety. Always check the summation of leakage currents when the <i>Expression</i> MRI Patient Monitoring System is connected to additional external equipment.▪ Do not remove the input/output door or leave the input/output port uncovered while in the MR system room during procedures. Degradation of system performance may result.▪ The manufacturer is not responsible for any radio or TV interference caused by unauthorized modifications to the radios within this equipment. Such modification could inhibit proper system communication. |
|--|

5 SYSTEM POWER-UP

Follow the steps below to perform system power-up and operational verification.

Step	Action
1.	Install batteries into the wireless ECG and SpO ₂ modules; see Section 3.2.2.
2.	Turn ON the Cart or PMC (using the power switch located to the left of the patient connection area).
3.	Turn ON the DCU (using the power switch located on the front lower left corner of the DCU).
4.	Verify proper communication between the WECG module, WSpO ₂ module, DCU, and Cart (or PMC) by checking the power indicator LED on each component; see Section 6.5.3.
5.	Verify proper operation of each patient parameter; see Section 6.

5.1 Removing AC Mains Power

To remove the *Expression* MRI Patient Monitoring System (Cart, PMC, or DCU) from AC mains power, use one of the following methods:

- Remove the AC power cord from the AC mains outlet; or
- Remove the DC power cord from the rear input port of the device.

6 TEST AND INSPECTION

This section details Test and Inspection instructions intended to verify system operations.

6.1 When to Test

When to Perform Tests	Service Event (When performing...	Test Required ...Complete these tests)
	Installation	Perform Visual Inspection and Power ON
	Preventative Maintenance	Perform Visual Inspection, Power ON, and Assurance Tests
	All Repairs	Perform Visual Inspection, Power ON, and Assurance Tests
	Upgrade	Perform Visual Inspection, Power ON , and Assurance Test.
	All other service events	Perform Visual Inspection, Power ON , and Assurance Test.

6.2 Test and Inspection Matrix Checklist

Test and Inspection Matrix:	Test Block	Test or Inspection to be Performed	Expected Test Results	Record the Results
	Visual	Inspect the unit and cables for damage.	If Yes, Visual test is passed	P or F
	Power ON	Verify normal power up.	Pass or Fail	P or F
	Performance	Perform the parameter tests as described in the assurance block.	Pass or Fail	P or F
	Safety	No safety test is required on this system.	N/A	N/A

6.3 Performance Assurance Test Checklist

Performance Assurance Tests:	Section/Test Description	Expected Test Results	Record the Results	Actual
		Verify that both Power Indicator LED's are illuminated GREEN on the DCU and on the WPU.	Pass or Fail	P or F
	Verify communication (COMM) between the DCU, WPU, and the WECG and WSPO2 remotes.	Pass or Fail	P or F	
	Verify DCU, WPU, and WECG and WSPO2 Battery Icons displayed on DCU	Pass or Fail	P or F	
	WECG COMM			
	Verify Trace A is a sequence of moving QRS pulses without jittering.	Pass or Fail	P or F	
	Verify 60 +/-1 BPM	59-61 BPM	P or F	
	WSPO2 COMM			
	Enable & turn ON SPO2; verify PROBE OFF when there is no finger inserted into the probe	Pass or Fail	P or F	
	Verify smooth waveform w/normal SPO2 reading	Pass or Fail	P or F	
	NIBP VERIFICATION			
	Verify that the Pneumatic Leak Test High (1 st row) numbers have a difference between PEAK and FINAL of ≤ 10	Pass or Fail	P or F	
	Verify that the Pneumatic Leak Test Low (2nd row) numbers have a difference between PEAK and FINAL of ≤ 10	Pass or Fail	P or F	
	NIBP OFFSET VERIFICATION 10 ± 2	8-12	P or F	
	Calibration Accuracy Check, Verify 250 ± 5 mmHg on both sides	245-255	P or F	
	NIBP Over-Pressure(Adult) PRI: 285 ± 4 mmHg, SEC: 295 ± 4 mmHg <i>Verify overpressure is displayed</i>	(281-289) (291-299)	P or F	
	NIBP Over-Pressure(Neo) PRI: 156 ± 4 mmHg, SEC: 150 ± 4 mmHg <i>Verify overpressure is displayed</i>	(152-160) (146-154)	P or F	
	NIBP Adult cuff test	Pass or Fail	P or F	
	NIBP Dead Man (Adult)	Pass or Fail	P or F	
	NIBP Neonatal cuff test	Pass or Fail	P or F	
	NIBP Dead Man (Neo)	Pass or Fail	P or F	
	Leak Time-Out (Adult)	Pass or Fail	P or F	
	Leak Time-Out (Neo)	Pass or Fail	P or F	
	Calibrate Error test	Pass or Fail	P or F	
	INVASIVE PRESSURE VERIFICATION			
	Verify Invasive Pressures: P1/P2 at 0, 50, 100, 150, 200, 240 +/- 1%	(-1-(-1), (49-51), (99-101), (148-152), (198-202), (238-242)	P or F	

Performance Assurance Tests (Continued):	Section/Test Description	Expected Test Results	Record the Results	Actual
		AGENT VERIFICATION (Only if repairing Service number 453564099881 or 453564175761)		
	Verify (Adult) flow detection 200ml/min. ±20ml/min	180-220 ml/min	P or F	
	CO2 OCCLUSION message and flow drop	Pass or Fail	P or F	
	Verify (Neo) flow detection 150ml/min. ±15ml/min	135-165 ml/min	P or F	
	Verify left port flow rate is 35ml/min±15ml/min	20-50 ml/min	P or F	
	Verify right port flow rate is 165ml/min±15ml/min	150-180 ml/min	P or F	
	Apply 10% CO2 and verify 76mmHg ± 9mmHg	67-85 mmHg	P or F	
	O2 Sensor Verification	Pass or Fail	P or F	
	ETCO2 VERIFICATION (Only if repairing Service number 453564155341 or 453564175791)			
	Verify "READJUSTING CO2 ZERO" message	Pass or Fail	P or F	
	Verify ETCO zero and flow value 80ml/min ± 16ml/min	64-96 mmHg	P or F	
	CO2 OCCLUSION message displayed within 30 seconds	Pass or Fail	P or F	
	Apply 10% CO2 and verify 76mmHg ± 9mmHg	67-85 mmHg	P or F	
	RESPIRATION VERIFICATION			
	Verify normal respiration rate	Pass or Fail	P or F	
	TEMPERATURE VERIFICATION			
	Verify Ambient temperature within ± 2.0°C	Pass or Fail	P or F	

6.4 Recommended Frequency of Testing

Recommended Frequency of Testing:	Suggested Testing Timetable	
	Test	Frequency
	Performance Assurance	Recommended once a year (or as specified by local laws) and after any type of repair of the unit.
	Regular Preventative Maintenance	Recommended once a year or after repair.

6.5 Test Process Description

The system under test must be handled in compliance with ESD procedures, and as detailed below.

6.5.1 Test Equipment Requirements

The following equipment is required when testing the *Expression* Patient Monitoring System:

- 453564185591 Wireless WECG Module with AC599 ECG leads.
- 453564185581 Wireless SP02 Module (Gen 2) with a 452213305371 SpO2 Fiber Optic Sensor.
- 989803169201 Power Adapter MRI with cable AC517A AC517B, plus AC power cord HE02.
- DCU/ Cart rechargeable battery P/N 9093 (453564067261) or 989803169491 (partially discharged).
- WSPO2/WECG rechargeable battery P/N 9065.
- A standard computer keyboard and VGA computer monitor w/video port cable.
- Adult NIBP cuff IRI 9070E.
- Neonatal NIBP cuff IRI AN01A.
- Class II Patient Simulator (medSim 300 model) or equivalent.
- Pressure (IBP) Simulator.
- Body Temp Probe (989803162531)
- OMEGA FL-211 Flowmeter or equivalent (and sample line).
- Manometer (Baumanometer) or equivalent.
- Class II DMM or equivalent.
- Chest Pneumograph sensor (bellows) PN 94023.

6.5.2 Initial AC Power-Up

With the Power Supply (P/N 989803169201 or P/N 989803168201) connected to the AC mains power, verify that the Power Indicator LEDs on the DCU and Cart (or PMC) are illuminated GREEN.

6.5.2.1 ETCO2 Option Only







Verify that the ETCO2 parameter is turned ON in the SERVICE/SYSTEM CONFIG menu.

6.5.3 Operational Tests

Use the tests in this section to verify system operations.

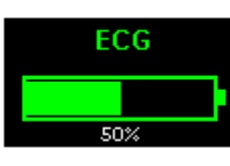
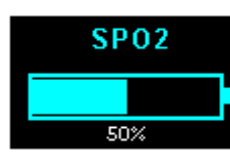
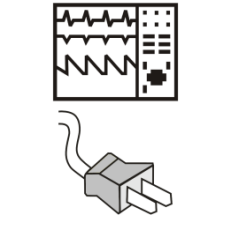
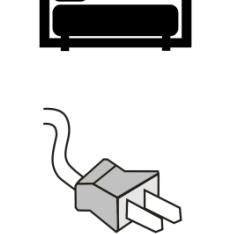
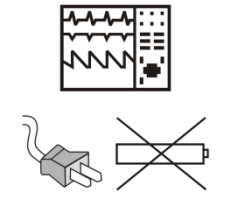
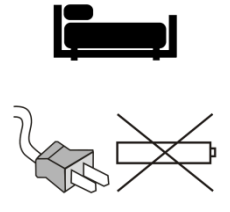
6.5.3.1 System Communication Verification

With the DCU and Cart (or PMC) powered-up and booted, verify communication (COMM) between the DCU, Cart, and the WECG and WSPO2 remotes. Verify that for all Conditions Tested the icons for the DCU, WPU, WECG and WSPO2 remotes are present on the DCU as depicted in Table 1, below:

Table 1				
Conditions Tested	DCU System Icons			
	DCU	WPU	WECG	WSPO2
DC Power (batteries only)				
AC Power with batteries installed			N/A	N/A
AC Power without batteries installed			N/A	N/A
No COMM	N/A			

6.5.3.2 WECG Communication

Perform the following test to verify WECG Communication with the system.

Setup:

- Attach the leads of the WECG remote to the medSim Patient Simulator, as indicated in Table 2, below. (Table 3 illustrates the ECG Leads to Lead Wires/Colors Scheme.)

Table 2		Table 3	
ECG Lead Color	Patient Simulator Terminals	ECG Lead(s)	Patient Simulator Lead Wires
GREEN	RL	I	WHITE, BLACK
WHITE	RA	II	WHITE, RED
BLACK	LA	III	BLACK, RED
RED	LL		

- Set the Patient Simulator to output a 1.0mV QRS pulse at 60BPM (NORMAL SINUS mode).
- Power-up the WECG remote by inserting a rechargeable battery.
- **LEAD 1 (1.0mV)**

Within the EC menu of the simulator set:

TRACE A LEAD to I

SCALE of 10 mm/mV

HR TONE SOURCE and select **QRS**

Verification:

- DCU TRACE A shows a waveform sequence of moving QRS pulses without jitter.
- The ECG numeric shows a count of 60 ± 1 BPM.
- The QRS Heart Rate Tone is present with NO double tones.

6.5.3.3 WSpO2 Communication

Perform the following test to verify WSpO2 Communication with the DCU.

Setup:

- In the SETUPS / PARAMETER SELECTION enable SpO2.
- Connect a SpO2 probe to the WSpO2 sensor, and power-up with a battery.

Verification:

- With the no finger placed inside the probe, verify that PROBE OFF is displayed.
- With a finger tip placed inside the probe, verify an SPO2 (pulse) waveform.
- With a finger tip placed inside the probe, verify that a reasonable SPO2 number (95 - 100) is displayed.

6.5.3.4 NIBP Verification

6.5.3.4.1 Pneumatic Leak Test High (1st row)

Setup:

- With the patient setup as ADULT, connect an Adult cuff (IRI 9070E) and hose to the NIBP ports. Tightly wrap the cuff around a fixed object.

Verification:

- Verify that at the end of each leak test cycle (a minimum of two cycles) the difference between PEAK and FINAL is ≤ 10 .

6.5.3.4.2 Pneumatic Leak Test Low (2nd row)

Setup:

- With the patient setup as ADULT, connect an Adult cuff (IRI 9070E) and hose to the NIBP ports. Tightly wrap the cuff around a fixed object.

Verification:

- Verify that at the end of each leak test cycle (a minimum of two cycles) the difference between PEAK and FINAL is ≤ 10 .

6.5.3.4.3 NIBP Offset Verification

Setup:

- Apply no pressure.

Verification:

- Verify in the SETUPS / SERVICE (BIO-MED) / NIBP TEST / CALIBRATE menu that the offset reading on the primary (PRI) port is 10 ± 2 .

6.5.3.4.4 Calibration Accuracy Check

A) Setup:

- PATIENT mode set to ADULT, and 250mmHg pressure applied to NIBP Pump (right) port.

A) Verification:

- Verify that the PRESS READING of the SEC transducer in the NIBP CAL window indicates 250 ± 5 mmHg.

B) Setup:

- PATIENT mode set to ADULT, and 250mmHg pressure applied to NIBP Pump (right) port.

B) Verification:

- Verify that the PRESS READING of the PRI transducer in the NIBP CAL window indicates 250 ± 5 mmHg.

6.5.3.4.5 Overpressure Adult

A) Setup:

- Set the pressure applied by the NIBP (right) port to 295 ± 4 mmHg.

A) Verification:

- Verify that over-pressure (bleed down) occurs, and that “OVER PRES” is displayed.

B) Setup:

- Set the pressure applied by the NIBP (right) port to 285 ± 4 mmHg.

B) Verification:

- Verify that OVER PRES is displayed.

6.5.3.4.6 Overpressure Neonatal

A) Setup:

- With PATIENT mode set to NEO, set the pressure applied by the NIBP (right) port to 150 ± 4 mmHg.

A) Verification:

- Verify that over-pressure (bleed down) occurs, and “OVER PRES” is displayed.

B) Setup:

- With PATIENT mode set to NEO, set the pressure applied by the NIBP (right) port to >142 but <150 mmHg.

B) Verification:

- Verify that the OVER PRES alarm activates within 15 seconds.

C) Setup:

- With PATIENT mode set to NEO, set the pressure applied by the NIBP (right) port to 156 ± 4 mmHg.

C) Verification:

- Verify OVER PRES is displayed.

Note: *The pressure will not fall during this test step.*

D) Setup:

- With PATIENT mode set to NEO, set the pressure applied by the NIBP (right) port to >142 but <150 mmHg.

D) Verification:

- Verify that the “OVER PRES” alarm activates within 15 seconds.

6.5.3.4.7 Adult Cuff Test

Setup:

- With an adult cuff (IRI 9070E) connected to the NIBP ports and the cuff placed around an arm, start the NIBP function.

Verification:

- Verify that the cuff inflates to approximately 170mmHg, and that the cuff deflates when a blood pressure determination has been reached.
- Verify that those systolic, mean and diastolic pressure numerics are present in the NIBP menu.

6.5.3.4.8 Adult Dead Man Cuff

Setup:

- With an adult cuff (IRI 9070E) connected to the NIBP ports and the cuff placed around a fixed object with an approximate diameter of 1 inch, start the NIBP function.

Verification:

- Verify that the unit displays a zero reading at the end of the NIBP cycle.

6.5.3.4.9 Neo-Natal BP

Setup:

- With the PATIENT mode set to NEO, a neonatal cuff (IRI AN01A) connected to the NIBP ports, the cuff placed around a finger that is held above shoulder height (to insure blood pressure is below 100mmHg), start the NIBP function.

Verification:

- Verify that the cuff inflates to approximately 130mmHg, and that the cuff deflates when a blood pressure determination has been reached.
- Verify that systolic, mean, and diastolic pressure numerics are present in the NIBP menu; and, that the values are normal for the operator's neo finger pressure.

6.5.3.4.10 Neo-Natal Dead Man Cuff

Setup:

- With the PATIENT mode set to NEO, a neonatal cuff (IRI AN01A) connected to the NIBP ports and the cuff placed around a fixed object with an approximate diameter of 1 inch, start the NIBP function.

Verification:

- Verify that the unit displays a zero reading at the end of the NIBP cycle.

6.5.3.4.11 Leak Time Out, Adult

Setup:

- With the PATIENT mode set to ADULT, all cuff connections removed and all NIBP ports open, start the NIBP function.

Verification:

- Verify that the pump shuts off within 6 seconds ± 1.5 seconds, and that the error message NOT INFLATING is displayed in the NIBP menu.

6.5.3.4.12 Leak Time Out, Neo-Natal

Setup:

- With the PATIENT mode set to NEO, all cuff connections removed and all NIBP ports open, start the NIBP function.

Verification:

- Verify that the pump shuts off within 6 seconds ± 1.5 seconds and that the error message NOT INFLATING is displayed in the NIBP menu.

6.5.3.4.13 Calibrate Error**Setup:**

- With the unit NOT in STANDBY mode and 15mmHg pressure applied, push the NIBP START/STOP key.

Verification:

- Verify that the pump does not start and that the CALIB message appears within 30 seconds.

6.5.3.5 Invasive Pressure Verification**A) Setup:**

- With P1 & P2 turned ON in the SETUPS / SERVICE / SYSTEM CONFIG screen, and P1 & P2 turned ON in the SETUPS / PARAMETERS SELECTION menu, connect the IBP Simulator to the P1 Port.

A) Verification:

- Verify that the P1 menu on the DCU displays the pressures within the given tolerances as listed in Table 4, below.

Pressure Transducer Simulator	Trace P1 (P2) Numeric Display
0	0 ±1
240	240 ±2
0	0 ±1
50	50 ±1
100	100 ±1
150	150 ±2
200	200 ±2
240	240 ±2
250	OVR

Note: *The systolic, diastolic and mean values should read within ±1mmHg of one another. If any readings are out of tolerance, change the simulator and cable, then repeat the test. If the test fails a total of 3 times after 3 unique simulators and cables, the IBP module is faulty.*

B) Setup:

- With P1 & P2 turned ON in the SETUPS / SERVICE / SYSTEM CONFIG screen, and P1 & P2 turned ON in the SETUPS / PARAMETERS SELECTION menu, connect the IBP Simulator to the P2 Port.

B) Verification:

- Verify that the P2 menu on the DCU displays the pressures within the given tolerances as listed in Table 4, above.

6.5.3.6 Agents Verification (*perform only if Agents is installed*)

6.5.3.6.1 Agents Flow Test

A) Setup:

- With AGENTS turned ON and PATIENT set to ADULT in the SETUPS / PARAMETER SELECTION menu, a sample line connected to the agents water trap, and the Flowmeter connected to the end of the sample line, open the exhaust port.

A) Verification:

- Verify that the flow is 200ml/min \pm 20ml/min.

B) Setup:

- With AGENTS turned ON and PATIENT set to ADULT in the SETUPS / PARAMETER SELECTION menu, a sample line connected to the agents water trap, and with the sample line input blocked, open the exhaust port.

B) Verification:

- Verify that the message CO2 OCCLUSION is displayed within 30 seconds.

C) Setup:

- With AGENTS turned ON, a sample line connected to the agents water trap and the Flowmeter connected to the end of the sample line, block the exhaust port.

C) Verification:

- Verify that the flow drops to 0ml/min.

D) Setup:

- With AGENTS turned ON and PATIENT set to NEO in the SETUPS / PARAMETER SELECTION menu, a sample line connected to the agents water trap, and the Flowmeter connected to the end of the sample line, open the exhaust port.

D) Verification:

- Verify that the flow is 150ml/min \pm 15ml/min.

E) Setup:

- With the water trap removed, the Flowmeter connected to the left port of the water trap receptacle (as viewed when facing the monitor), and the right port of the water trap receptacle left open.

E) Verification:

- Verify that the flow is 35ml/min \pm 15ml/min.

F) Setup:

- With the water trap removed, the Flowmeter connected to the right port of the water trap receptacle (as viewed when facing the monitor), and the left port of the water trap receptacle left open.

F) Verification:

- Verify that the flow is 165ml/min \pm 15ml/min.

G) Setup:

- With 10% (76mmHg) CO₂ applied to the unit, allow CO₂ gas to flow for at least 2 minutes.

G) Verification:

- Verify that the unit detects CO₂ and measures 76mmHg \pm 9mmHg. Also, verify the respiration count does not exceed "0" while gas is flowing.

6.5.3.6.2 O2 Sensor Verification

Setup:

- With the Artema O2 Sensor into sensor port at the back of the Cart, select GAS CAL / O2 INIT CAL in the SERVICE MENU.

Verification:

- Verify that the O2 sensor is within its expiration date.
- Verify an O2 value of 21 percent is displayed (at ambient oxygen) in the Agents box after calibration is completed.
- Verify an O2 value of 21 percent is displayed (at ambient air) in Agents box after the calibration is completed.
- If the sensor being tested does not give the appropriate results but a second sensor does operate properly, lead troubleshooting procedures need to be undertaken.

6.5.3.7 ETCO2 Flow Test Verification (*perform only if AB151 ETCO2 installed*)

A) Setup:

- With ETCO2 turned ON in the SETUPS/PARAMETER SELECTION menu, a sample line connected to the agents water trap, the warm-up period satisfied, and ZERO CAL selected.

A) Verification:

- Verify that “READJUSTING CO2 ZERO” is displayed at the top center of the DCU screen.

B) Setup:

- With a water trap installed, a sample line connected to the water trap, and the Flowmeter connected to the end of the sample line.

B) Verification:

- Verify that the flow is 80 ml/min \pm 16ml/min.

C) Setup:

- Block the sample line input.

C) Verification:

- Verify that the message CO2 OCCLUSION is displayed within 30 seconds.

D) Setup:

- With 10 percent (76mmHg) CO2 applied to the unit, and CO2 gas flowing for at least 2 minutes.

D) Verification:

- Verify that the unit detects CO2, and measures 76mmHg \pm 9mmHg.

6.5.3.8 Respiration Verification

Setup:

- With REPSIRATION turned ON and a respiration bellows connected to the WSPO2 respiration port, attach the bellows to the chest/stomach region.

Verification:

- Verify DCU respiration displays a rate consistent with the normal respiration rate (typically 10-16BPM).

6.5.3.9 Temperature Verification

Setup:

- Set the PATIENT mode to ADULT, the SETUPS/PARAMETER SELECTION/TEMP to ON, and the (989803162531) body temp probe connected to the Temperature port.

Verification:

- Verify that the reading is at the ambient temperature°C within \pm 2°C.

6.5.4 Electrical Safety Testing

The electrical safety of the system has been verified to meet IEC 60601-1-1. The service procedures have been specified so that it is not necessary to repeat electrical safety testing after completing repair.

7 REMOVAL AND REPLACEMENT

This section details removal and replacement techniques, including the network changes required for exchange components.

- WARNING:**
- Turn OFF and unplug AC mains power to the system, and remove the batteries before performing service to avoid injury and equipment damage.
 - Before return shipment, remove the antenna, accessories, and batteries from the Cart, WPU, PMC, and DCU to avoid damaging the equipment.

7.1 The Cart WPU

The instructions below detail removal and replacement of the WPU on a Cart.

7.1.1 WPU Removal from the Cart

1. Loosen the 2 Captivated Screws (P/N NS185N) on the Rear Base I/O Cover (P/N 453564088381) and then remove the cover from the Cart.

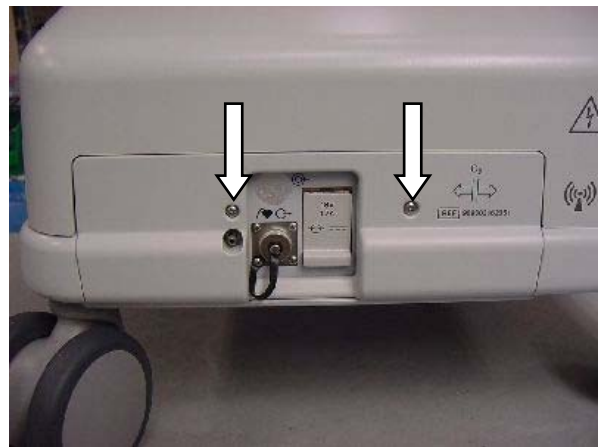

2. Remove the Screw (P/N 453564155941) from the WPU Cover (P/N 453564099841) and then lift the WPU Cover off the Base. (Retain the Screw for reassembly.)

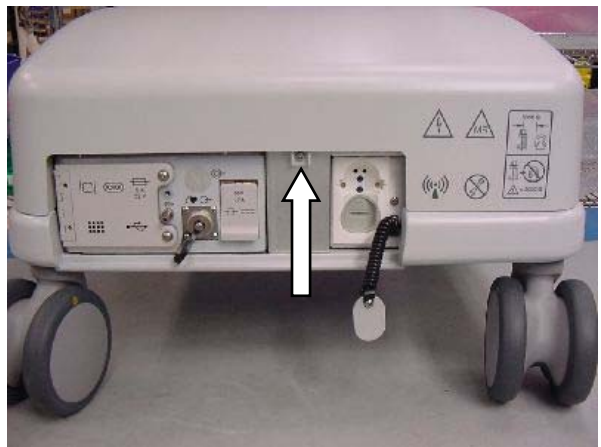

3. Remove the 2 Screws (P/N 453564155961) from the Cover (P/N 453564088191) by the Power Box.



4. Label all the pneumatic hoses with a corresponding identifier, and then disconnect the hoses from the ports on the WPU.



5. Disconnect all Fiber Optic and Multifunction Cables from the WPU chassis.

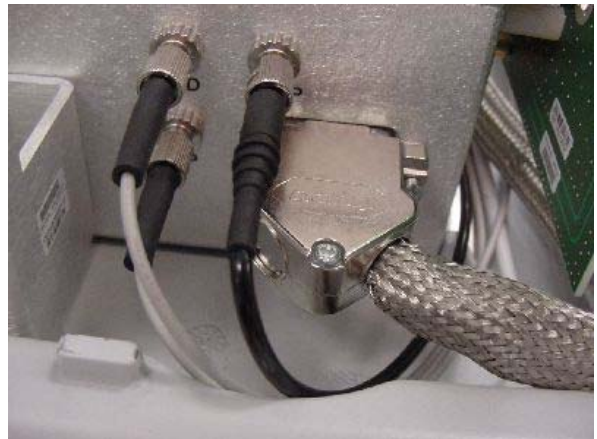

6. After ensuring that all loose parts are secure, carefully tilt the Cart forward and, while supporting the WPU, remove the 4 Screws (P/N 453564157091) that secure the WPU to the Base Casting. (Discard the 4 Screws.)



7. Remove the 3 Screws (P/N 453564155961) that secure the Shield (P/N 453564088281) to the chassis and then remove the Shield. (Discard the Screws.)

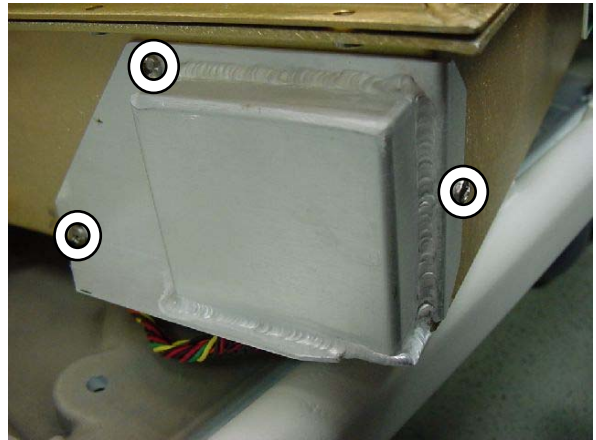

8. Disconnect the Battery Cable from AS222.

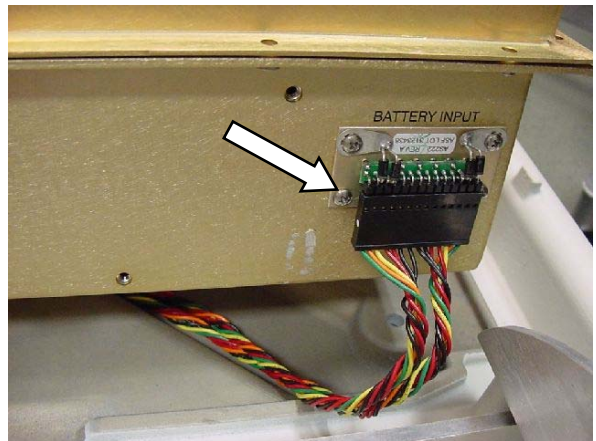

9. Disconnect the Antenna from the WPU.

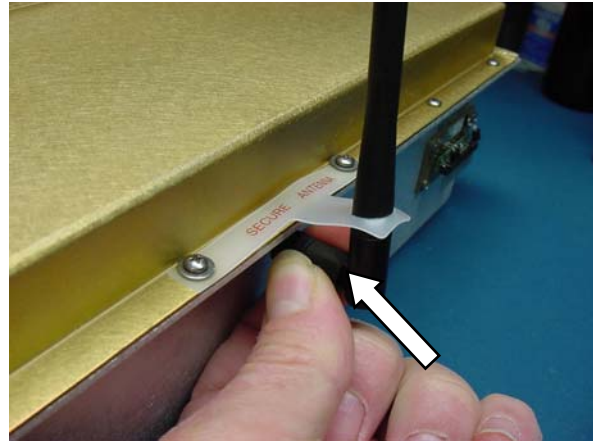

10. Remove the WPU from the Cart. Remove the Antenna Mast from the Antenna Bracket. Place the WPU and the Antenna aside for return shipment.

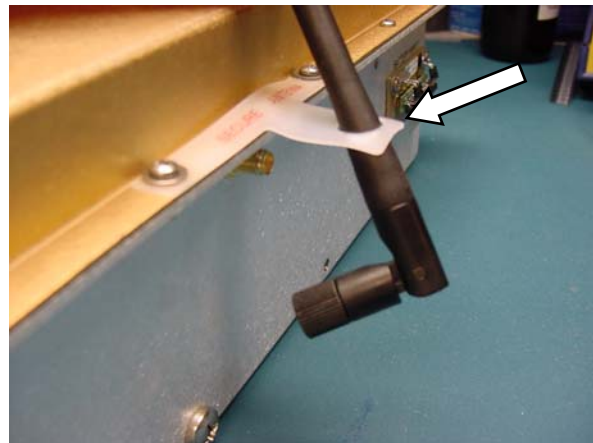

7.1.2 WPU Replacement into the Cart

1. Remove the replacement WPU from the shipping container, along with the supplied accessories. Insert the Antenna Mast into the Antenna Bracket.



2. Secure the Antenna to the Antenna Connector on the WPU.

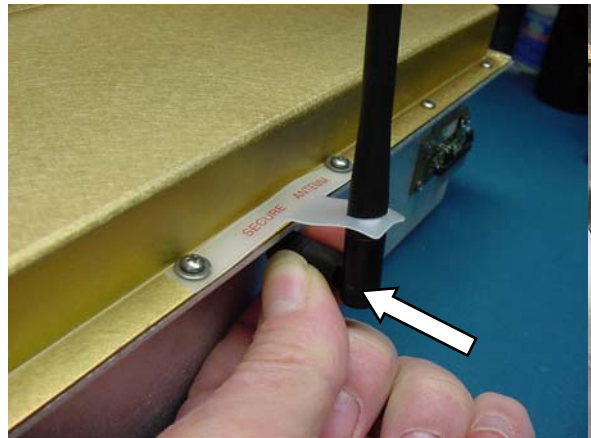

WARNING: The Antenna Mast must be inserted in the Antenna Bracket. Never loosen the Antenna Bracket Screws, as damage to the RF seal will occur.

3. Carefully place the WPU into the Cart. Ensure that the WPU is not pinching the Battery Cable then connect the cable to AS222.

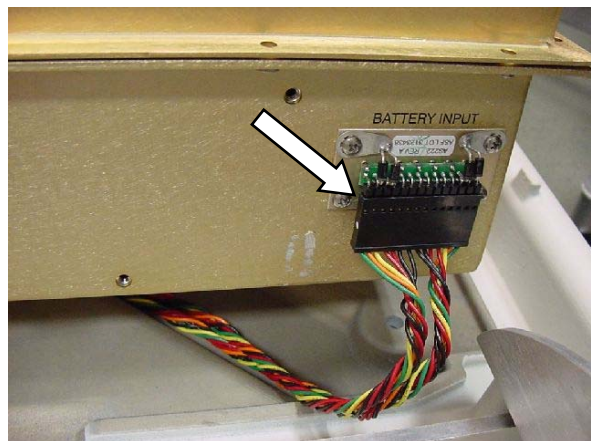

WARNING: Use care when connecting the Battery Cable, as sharp edges can cause damage to the wiring.

4. Attach the Shield to the WPU, using the 3 Screws (P/N 453564185231) from the supplied Screw Kit (P/N 453564185221).

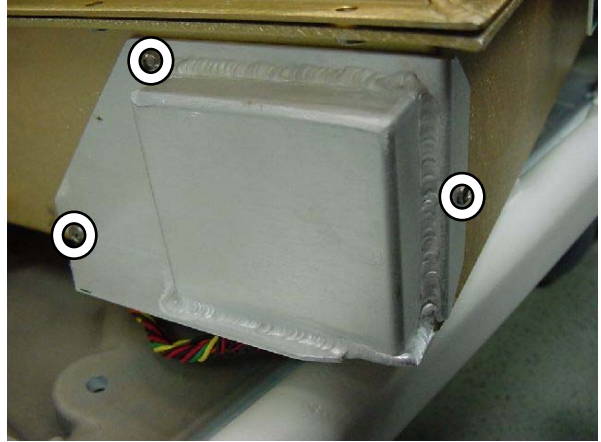

5. Connect the Multifunction Cable to the PCU/DCU Connector on the WPU and then tighten the Connector Retaining Screws.

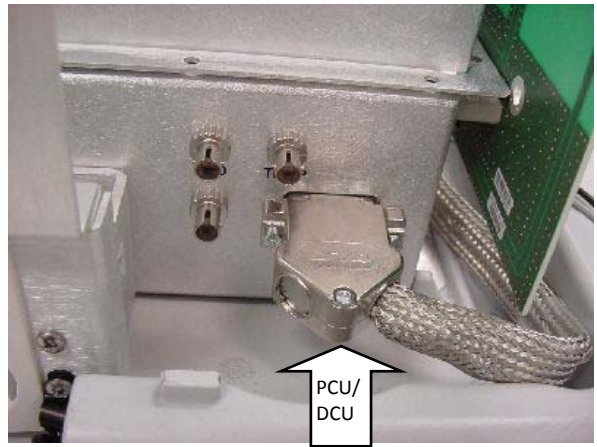

6. Connect the LED, TEMP, and IBP cables to the respective connectors on the WPU.

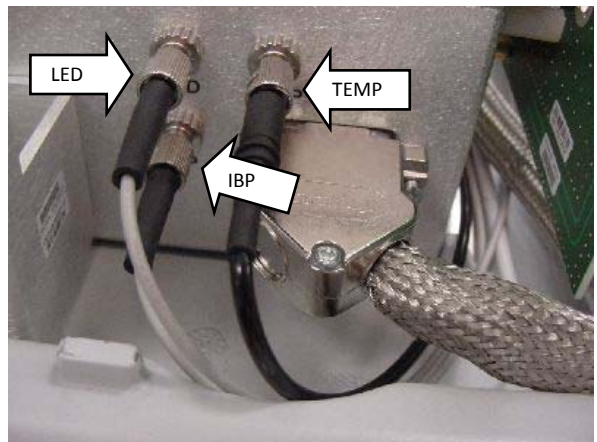

7. Verify again that the Battery Cable is not pinched. Start 4 Screws (P/N 453564157091) from the supplied Screw Kit (P/N 453564185231) through the Base Casting and into the WPU. Then carefully tilt the Cart forward and tighten the 4 Screws.

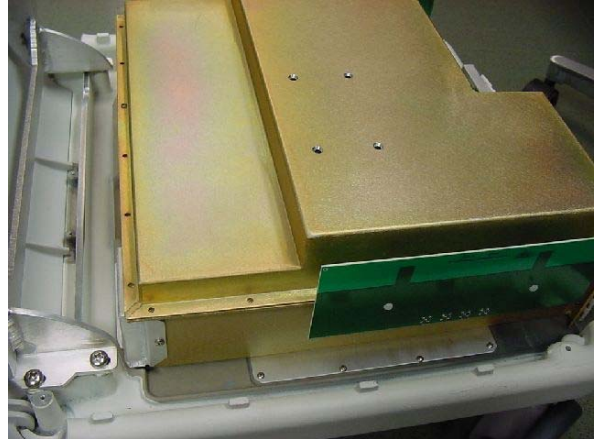

8. Reconnect all the pneumatic hoses to the respective ports on the WPU.



9. Replace the Cover by the Power Box using the 2 Screws (P/N 453564155961) from the supplied Screw Kit (P/N 453564185221).

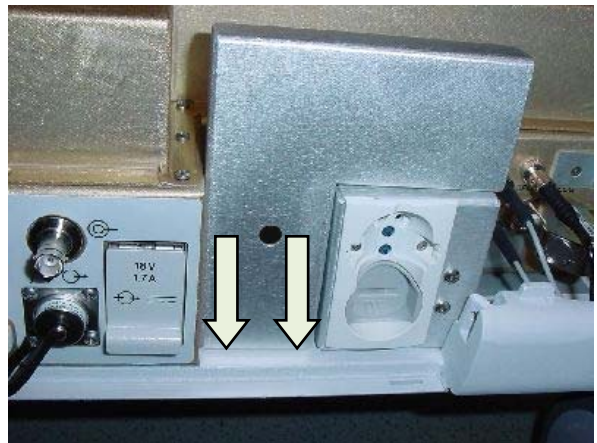

10. Test the functions; see Section 6.

11. Replace the WPU Cover and then secure it using the previously removed Screw (P/N 453564155941).



12. Install the Rear Base I/O Cover onto the Cart and tighten the 2 Captivated Screws. Configure the network; see Section 7.1.3.

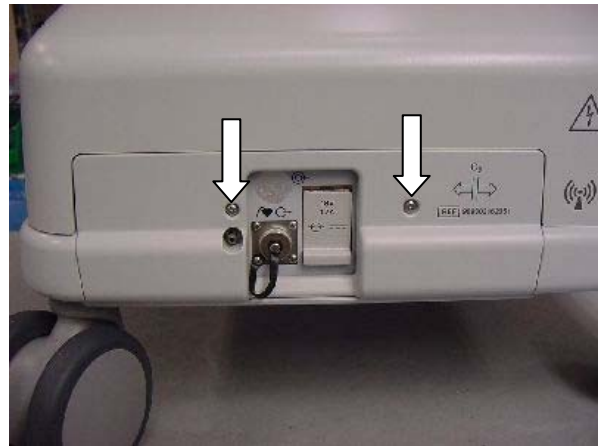

7.1.3 Exchange Network Setup

Note: *The following VERY IMPORTANT steps must be performed following an exchange.*

7.1.3.1 Network Channel Options

Obtain the system **Network** via the network label on the back of the Cart or by observing the network indicator at the bottom right of the DCU screen.

Ensure that a VGA display and a keyboard are connected to the Cart. Enter the keyboard navigator by typing “nav”. Press **F4** to enter the **SETUPS** menu. Select **SERVICE (BIO-MED)** then **SYSTEM CONFIG** and finally **NETWORK**. Enter the password (*the password is for Philips personnel only and can be attained by calling Technical Support*) to set the network option per the observed customer DCU network indicator.

Channel Options
Network A
Network B
Network C
Network D
Network E

Note: Use RETURN to exit the SYSTEM CONFIG menu, not ESC.

7.1.3.2 Exchange Parameter Disabling

If the exchange assembly contains options not purchased by the customer, the options should be disabled. (Options connectors, if not purchased, will not be installed on the front of the Cart.)

Ensure that a VGA display and a keyboard are connected to the Cart. Enter the keyboard navigator by typing “nav”. Press **F4** to enter the **SETUPS** menu. Select **SERVICE (BIO-MED)** then **SYSTEM CONFIG**, and finally select the **non-purchased parameter**. Enter the password to disable the parameter.

Note: Use RETURN to exit the SYSTEM CONFIG menu (not the ESC Key) and then cycle system power.

7.2 The PMC WPU

The instructions below detail removal and replacement of the WPU in the PMC.

7.2.1 WPU Removal from the PMC

1. Lift the Latches then remove the Battery Compartment Cover (P/N 453564169211) from the PMC.

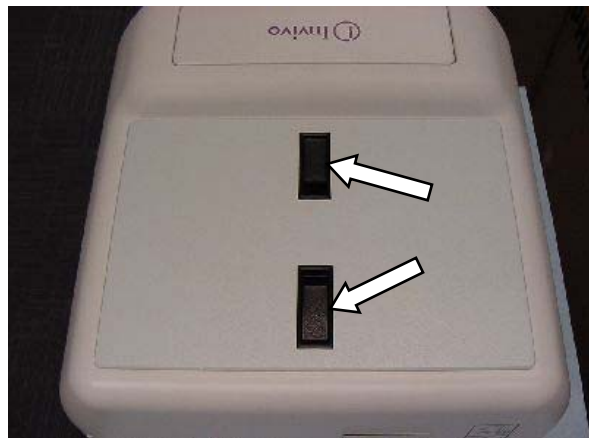

2. Pull the latch holding the Battery in the Battery Tray and then, using your other hand, remove the Battery (from the side opposite the connector). Repeat the process for the remaining Battery.

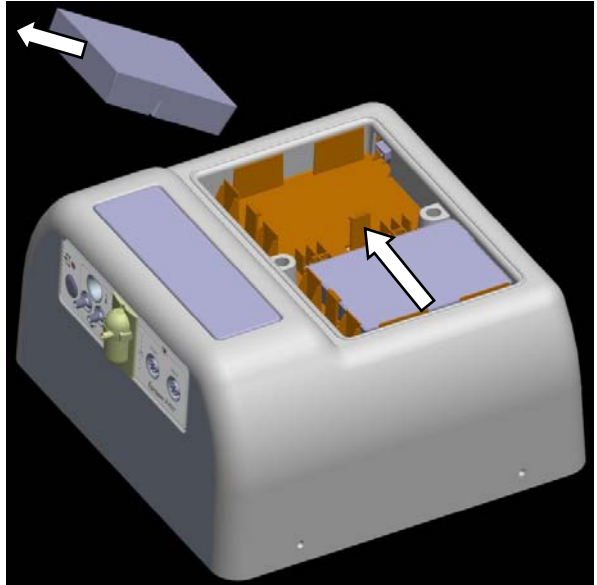

3. Remove the O2 Door Assembly (P/N 453564173991) from the PMC Cover.



4. Remove the Water Trap from the Water Trap Receptacle.



5. Remove the 4 Screws (P/N NS111N) that secure the PMC Cover (P/N 453564167621) to the Base and then carefully lift the Cover off the Base. (It may be necessary to push slightly on the Battery Tray.)



6. Disconnect all Fiber Optic and Multifunction Cables from the WPU chassis.



7. Cut the Cable Ties that secure the Multifunction Cable to the WPU chassis.

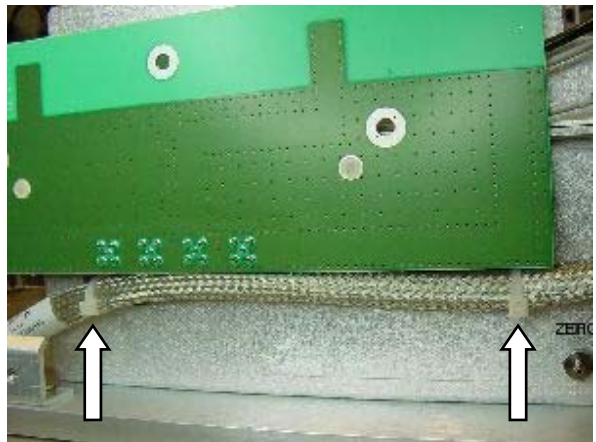

8. Cut the Cable Tie that secures the Battery Cable to the chassis. Also, remove the Antenna (then place it aside for shipment.)

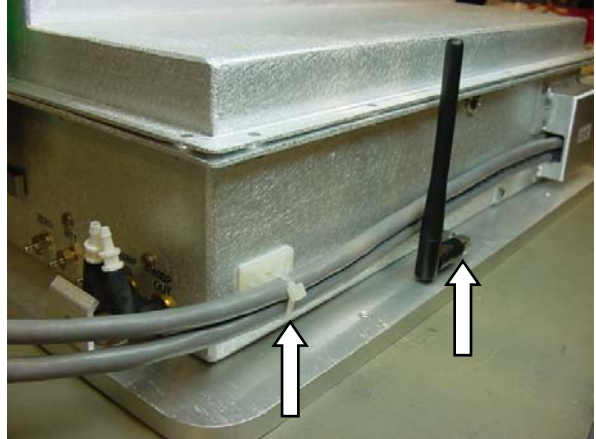

9. Remove the 3 Screws (P/N 453564155961) from the Shield (P/N 453564165251), and then remove the Shield from the WPU.



10. Remove the 2 Screws that secure the Battery Cable Ground Lugs to the WPU chassis. Then disconnect the Battery Cable from AS222 and move the assembly aside.

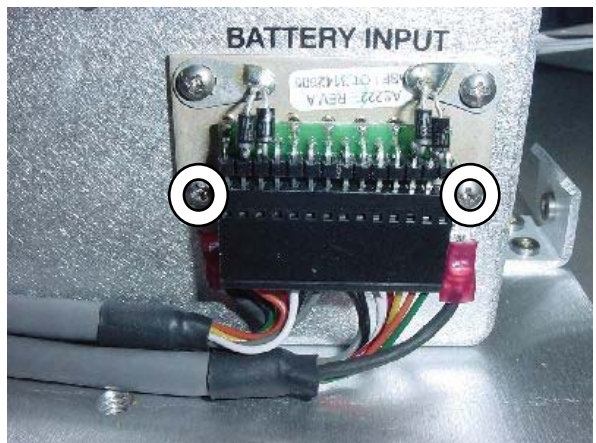

11. Label and then disconnect all the pneumatic hoses from the WPU ports.

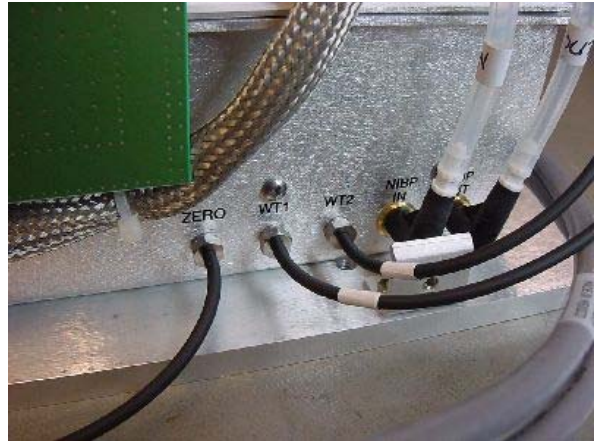

12. Remove the 4 Screws (P/N 453564157171) and the 4 Spacers (P/N 453564168171) that secure the PCU to the WPU. Then remove the PCU from the WPU and set the PCU aside.

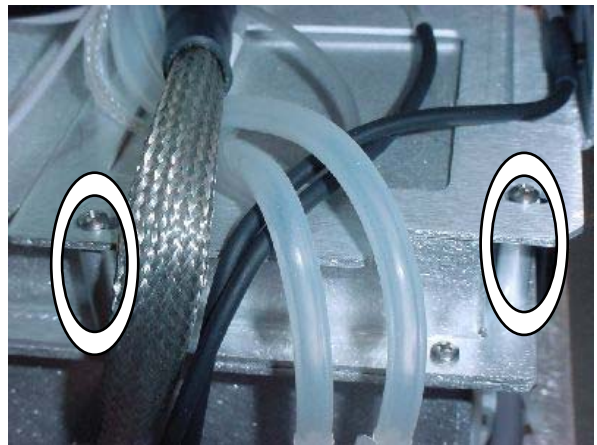

13. Carefully flip the WPU over and remove the 4 Screws that secure the WPU to the Mounting Plate. (Place the WPU aside for shipment.)



7.2.2 WPU Replacement into the PMC

1. Remove the replacement WPU from the shipping container, along with the supplied accessories. Secure the WPU to the Mounting Plate (P/N 453564166021) using 4 Screws (P/N 453564168691).



CAUTION: Torque the Mounting Plate Screws to 40 lb/ft +/- 1 lb/ft.

2. Carefully flip the assembly over and place the PCU atop the WPU.



3. Connect the Battery Cable to AS222. Then, while ensuring that the Antenna Mast extends into the bracket aperture, secure the Antenna to the connector on the WPU.

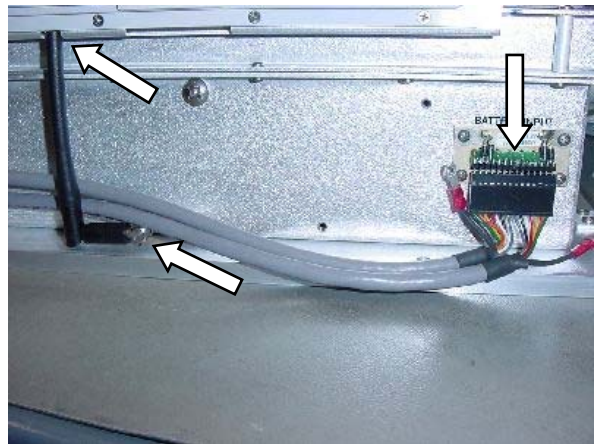

4. Secure the Battery Cable Ground Lugs to AS222 using the 2 Screws (P/N 453564109901).

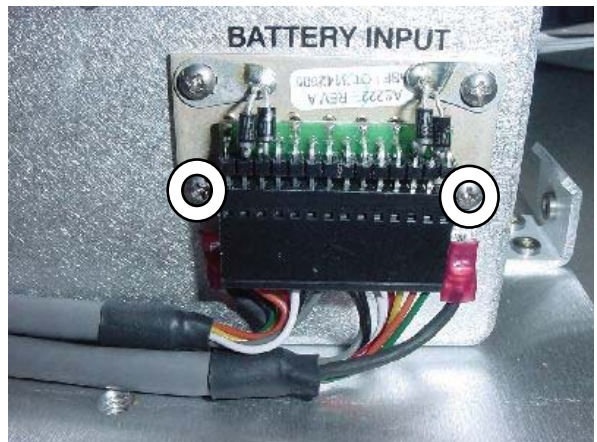

5. Position the Shield (P/N 453564165251) over AS222 and then secure it to the WPU using 3 Screws (P/N 453564155961).



Note: *It may be necessary to manipulate the Battery Cable to allow the Shield to properly seat.*

6. Install a Cable Tie (P/N HC19) through the clamp and around the Battery Cable. Pull the Cable Tie snug then trim the excess length.

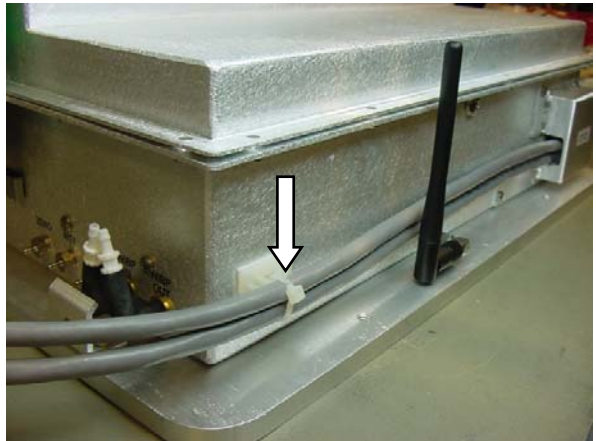

7. Secure the Multifunction Cable (P/N 453564163331) to the PCU/DCU Connector on the WPU chassis.



8. Position the Multifunction Cable to provide a small service loop at the connector and then install 2 Cable Ties (P/N HC04). Pull the Cable Ties snug then trim the excess length.

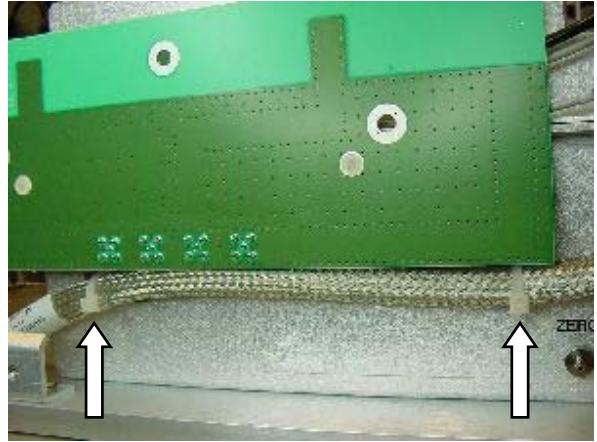

9. Connect the LED, TEMP, and IBP cables to the respective connectors on the WPU.

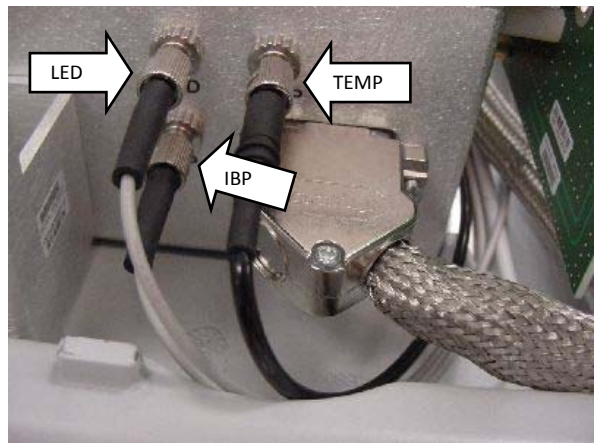

10. Route all Fiber Optic cables behind the Antenna PCB, as shown.

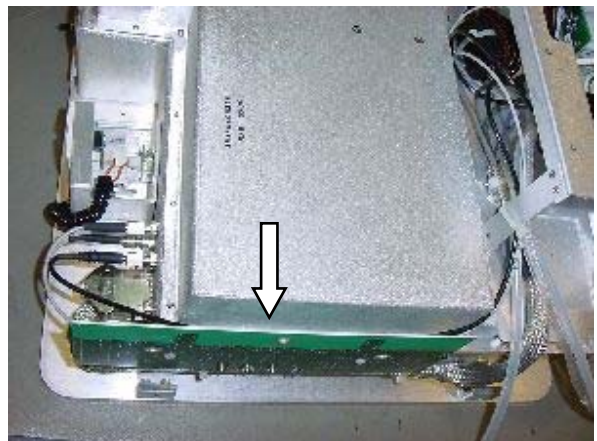

11. Except for the ZERO hose, reconnect the pneumatic hoses to the respective ports on the WPU.

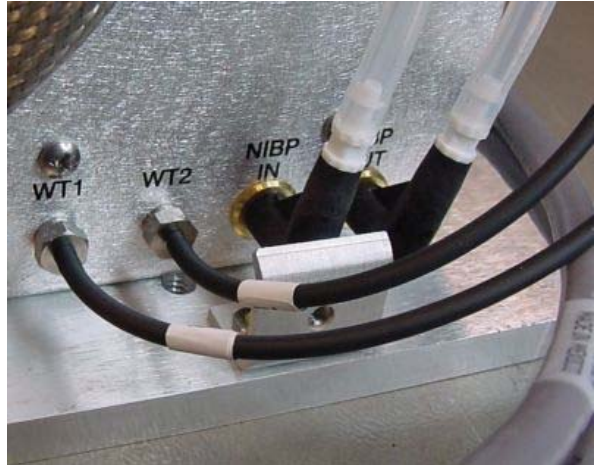

12. If equipped with Agents, proceed to Step 13; otherwise, cut Hose (P/N HP115) to 15 inches (6 cm) then connect one end to the ZERO port on the WPU and connect the other end to the Zero Port Filter. Install a Cable Tie (P/N HC19) through the clamp then loosely around the ZERO Hose. Trim any excess Cable Tie length.

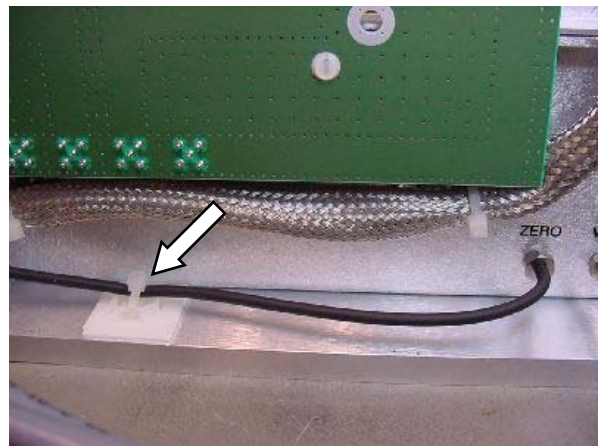

13. Install the Water Trap (P/N HP168 for Agents or P/N HP174 for ETCO2) on the Water Trap Receptacle on PCU.



14. Install the 4 Spacers (P/N 453564168171) and then secure the PCU using the 4 Screws (P/N 453564157171).

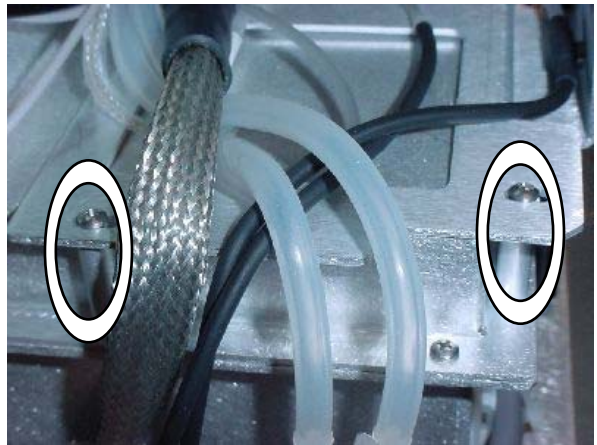
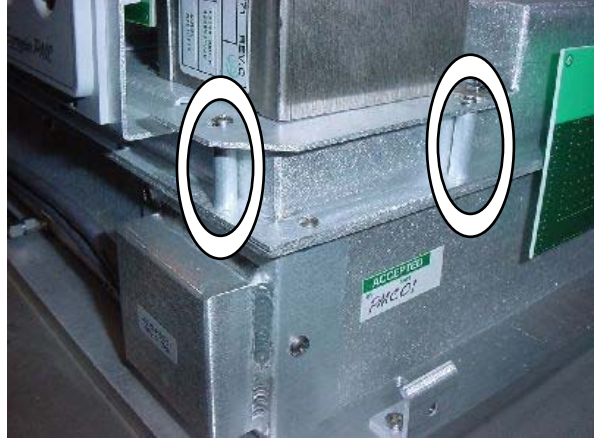

CAUTION: Position the PCU so that the Screws are positioned at the back of the slots; also ensure that the Antenna Mast remains captured.

15. Dress the cables and hoses through the cable clamp then close the clamp.



16. Test the functions; see Section 6.

17. After ensuring that no cables or hoses are pinched, install the Cover (P/N 453564167621) over the Battery Tray, PCU, and WPU. Secure the Cover using 4 Screws (P/N NS111N). Configure the network; see Section 7.2.3.



Note: *In some cases, it may be necessary to temporarily remove the Water Trap to install the Cover.*

18. Replace the O2 Door Assembly (P/N 453564173991) on the Cover.



7.2.3 Exchange Network Setup

Note: *The following VERY IMPORTANT steps must be performed following an exchange.*

7.2.3.1 Network Channel Options

Obtain the system **Network** via the network label on the back of the PMC or obtain it by observing the network indicator at the bottom right of the DCU screen.

Ensure that a VGA display and a keyboard are connected to the PMC. Enter the keyboard navigator by typing “nav”. Press **F4** to enter the **SETUPS** menu. Select **SERVICE (BIO-MED)** then **SYSTEM CONFIG** and finally **NETWORK**. Enter the password (*the password is for Philips personnel only and can be attained by calling Technical Support*) to set the network option per the observed customer DCU network indicator.

Channel Options
Network A
Network B
Network C
Network D
Network E

Note: Use RETURN to exit the SYSTEM CONFIG menu, not ESC.

7.2.3.2 Exchange Parameter Disabling

If the exchange assembly contains options not purchased by the customer, the options should be disabled. (Options connectors, if not purchased, will not be installed on the PMC.)

Ensure that a VGA display and a keyboard are connected to the PMC. Enter the keyboard navigator by typing "nav". Press **F4** to enter the **SETUPS** menu. Select **SERVICE (BIO-MED)** then **SYSTEM CONFIG**, and finally select the **non-purchased parameter**. Enter the password (*the password is for Philips personnel only and can be attained by calling Technical Support*) to disable the parameter.

Note: Use RETURN selection to exit the SYSTEM CONFIG menu (not the ESC Key) and then cycle system power.

8 SERVICE PARTS

8.1 Non-Exchange Service Parts

The following Non-Exchange service parts are available.

Part Number (12NC/CMS #)	Non-Exchange Service Part Description
453564137611	CAB, FLP, LED, WPU, 3160
989803152181	ASSY, LINE CORD, 110 V, TESTED
453564060691	FUSE, 5AMP, ATO BLADE
453564060151	ANTENNA, 2.4GHZ, RA, MALE
453564137771	DOOR, CONN.PANEL, WPU, 3160
453564138721	SPRING, EJECTOR, BATTERY, 16LBS/IN
453564060011	WATER TRAP, DSPSBL, AGENTS, 3
453564060021	WATER TRAP, DSPSBL, ETC02, 3160
453564139551	LABEL, "ACCEPTED" W02
453564099841	COVER, WPU, CART, 3160P
453564088101	ASSY, BATTERY INTERFACE, WPU
453564088381	COVER, REAR, WPU, 3160P
453564088151	HANDLE, CART, 3160P
453564088231	CONN, LUMASENSE, BULKHEAD, 3160P
453564088241	CABLE, FO, LUMASENSE, 55.00 LG
453564060081	ASSY, BOX, IBP, PCU, 3160
453564138751	SVC "WARRANTY VOID" LABEL
453564138741	SVC LABEL,"NON-HOSP.CHK", SERVI
453564088111	CASTERS, LOCKING, 3160P
453564088121	CASTERS, NON-LOCKING, 3160P
453564107941	BEZEL ASSEMBLY
453564060621	FOOT, BLACK, PUSH RIVOT, .354
453564139481	SCR, #6-32 X 3/8 LG, PHMS-XR
453564133441	WASHER, FLAT, #6X.312X.048, S
453564088641	COVER, ACCESS, CONN, 3160P
453564139541	SCR, #6-32X 1/2LG,FHMS-XR, N
453564067261	BATTERY, MRI, 14.8V, 5.08 AH
453564178401	NUT, HEX M10 X 1,5, 8MM THICK SS, 316
989803162961	TETHER, KEY TOOL
989803152221	CAB, POWER, ADAPTER, 5FT, 3155 SER

Part Number (12NC/CMS #)	Non-Exchange Service Part Description (Continued)
989803152231	CAB, POWER, ADAPTER, 25FT, 3150
453564095861	ASSY, LATCH, SPRING, BATT, 3160P
453564113241	CAB, SWITCH, CART
453564099831	CAB, FO, LED, 55.00 LG
453564096581	CABLE, FO, IBP, 55.00 LG
453564107921	CAB, POLE MULTI-FNCTN, CART, 3160P
453564099491	ASSY, DOCKING, 3160P
453564088341	HOOK, LEFT, CART, 3160P
453564088331	HOOK, RIGHT, CART, 3160P
453564088401	HOOK, REAR, CART, 3160P
453564088391	HOLDER, ACCESSORIES, CART, 3160P
453564145951	BASKET, REMOVABLE, CART, 3160P
453564137941	PCA, CONN.ADPTR, IBP, 3160
453564137831	DOOR, POWER CONN, AS220, WPU, 3160
453564125581	ANTENNA, 2.4GHZ, STRAIGHT, MALE
453564156131	PANEL, FILLER, PRINTER PORT, DCU
989803169201	ASSY, POWER ADAPTER, MRI
453564060741	ASSY, PRINTER, THRM, GSI GROUP, AR42
453564088781	KNOB, 3160P
453564185591	REPLACEMENT WIRELESS WECG MODULE
453564185581	REPLACEMENT WIRELESS SP02 MODULE (GEN 2)
989803152881	BATT.3.7V, WRLS.PAT.MDLE.PHILIP
453564060751	LABEL, PRINTER DOOR, LT. GRAY
453564156131	PANEL, FILLER, PRINTER PORT, DCU
989803162051	ANESTHETIC OXYGEN (O2) SENSOR, 3160P
453564155461	PCA, WPU DIVERSITY ANTENNA
989803162531	BODY TEMP PROBE (BOX OF 10)

8.2 Exchange Service Parts

The following Exchange service parts are available.

Exchange P/N (12NC/CMS #)	Exchange Service Part Description
453564180091	EXCHANGE ASSY, WPU, 3160P ETCO2, IBP, TEMP
453564181201	EXCHANGE ASSY, WPU, 3160P AGENTS, IBP, TEMP
453564181221	EXCHANGE ASSY, WPU, 3160P PMC HORZ/VERT ETCO2, IBP, TEMP
453564181231	EXCHANGE ASSY, WPU, 3160P PMC HORZ/VERT AGENTS, IBP, TEMP
453564180101	EXCHANGE, ENGLISH, ASSY, DCU, W/RECORDER, 3160P
453564194451	EXCHANGE, DANISH, ASSY, DCU, W/RECORDER, 3160P
453564194461	EXCHANGE, DUTCH, ASSY, DCU, W/RECORDER, 3160P
453564194471	EXCHANGE, FRENCH, ASSY, DCU, W/RECORDER, 3160P
453564194481	EXCHANGE, GERMAN, ASSY, DCU, W/RECORDER, 3160P
453564194491	EXCHANGE, ITALIAN, ASSY, DCU, W/RECORDER, 3160P
453564194501	EXCHANGE, NORWEGIAN, ASSY, DCU, W/RECORDER, 3160P
453564194511	EXCHANGE, PORT-BRAZIL, ASSY, DCU, W/RECORDER, 3160P
453564194521	EXCHANGE, PORT-PORT, ASSY, DCU, W/RECORDER, 3160P
453564194531	EXCHANGE, SPANISH, ASSY, DCU, W/RECORDER, 3160P
453564194541	EXCHANGE, SWEDISH, ASSY, DCU, W/RECORDER, 3160P
453564156991	EXCHANGE, ENGLISH, ASSY, DCU, W/O RECORDER, 3160P [2ND DCU]
453564194351	EXCHANGE, DANISH, ASSY, DCU, W/O RECORDER, 3160P [2ND DCU]
453564194361	EXCHANGE, DUTCH, ASSY, DCU, W/O RECORDER, 3160P [2ND DCU]
453564194371	EXCHANGE, FRENCH, ASSY, DCU, W/O RECORDER, 3160P [2ND DCU]
453564194381	EXCHANGE, GERMAN, ASSY, DCU, W/O RECORDER, 3160P [2ND DCU]
453564194391	EXCHANGE, ITALIAN, ASSY, DCU, W/O RECORDER, 3160P [2ND DCU]
453564194401	EXCHANGE, NORWEGIAN, ASSY, DCU, W/O RECORDER, 3160P [2ND DCU]
453564194411	EXCHANGE, PORT-BRAZIL, ASSY, DCU, W/O RECORDER, 3160P [2ND DCU]
453564194421	EXCHANGE, PORT-PORT, ASSY, DCU, W/O RECORDER, 3160P [2ND DCU]
453564194431	EXCHANGE, SPANISH, ASSY, DCU, W/O RECORDER, 3160P [2ND DCU]
453564194441	EXCHANGE, SWEDISH, ASSY, DCU, W/O RECORDER, 3160P [2ND DCU]

8.3 System Preventative Maintenance Parts

The following Preventative Maintenance parts are available.

Invivo Part Number	12NC	Preventative Maintenance Part Description	System	Quantity
9010F	989803152641	CAL GAS, AEROSOL CO-2	Agent/ ETCO2	1
HP169	453564060011	WATER TRAP, DSPSBL, AGENTS, 3160	Agent	1
94018	989803152661	KIT, SAMPLE, AGENTS, 3160	Agent	1
N/A	989803162051	ANESTHETIC OXYGEN (O2) SENSOR, 3160P	Agent	1
9093	453564067261	BATTERY, MRI, 14.8V, 5.08 AH	All	4
9065	989803152881	BATTERY, 3.7V, WRLS.PAT.MDLE, 3160	All	2
N/A	453564125581	ANTENNA, 2.4GHZ, VERTICAL, SMA MALE	All	1
HE61	453564060151	ANTENNA, 2.4GHZ, RA, MALE	All	1
HP174	453564060021	WATER TRAP, DSPSBL, ETCO2, 3160	ETCO2	1
94021	989803152541	KIT, SAMPLE, ETCO2, 3160	ETCO2	1

8.4 Service Numbers and Replacement/Exchange Parts





















The following Replacement/Exchange parts are available, with a disposition defined by the Repair Strategy.





















Service Number	Replacement/Exchange Part Description	Part Number	Repair Strategy
453564180091	WPU CART, 3160P W/ETCO2 OPTION	453564180091	Sub-Assembly Exchange
453564181201	WPU CART, 3160P W/AGENTS OPTION	453564181201	
453564181221	WPU PMC HORZ VERSION, 3160P W/ETCO2 OPTION	453564181221	
453564181231	WPU PMC HORZ VERSION, 3160P W/AGENTS OPTION	453564181231	
453564181221	WPU PMC VERT VERSION, 3160P W/ETCO2 OPTION	453564181221	
453564181231	WPU PMC VERT VERSION, 3160P W/AGENTS OPTION	453564181231	
453564185581	WIRELESS SPO2 MODULE	453564185581	Whole Unit Replacement
453564185591	WIRELESS WECG MODULE	453564185591	Whole Unit Exchange
453564180101	DCU, W/RECORDER ENGLISH	453564180101	
453564194451	DCU, W/RECORDER DANISH	453564194451	
453564194461	DCU, W/RECORDER DUTCH	453564194461	
453564194471	DCU, W/RECORDER FRENCH	453564194471	
453564194481	DCU, W/RECORDER GERMAN	453564194481	
453564194491	DCU, W/RECORDER ITALIAN	453564194491	
453564194501	DCU, W/RECORDER NORWEGIAN	453564194501	
453564194511	DCU, W/RECORDER PORT-BRAZIL	453564194511	
453564194521	DCU, W/RECORDER PORT-PORT	453564194521	
453564194531	DCU, W/RECORDER SPANISH	453564194531	



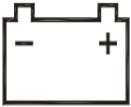



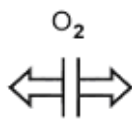















Service Number	Replacement/Exchange Part Description <i>(Continued)</i>	Part Number	Repair Strategy
453564194541	DCU, W/RECORDER SWEDISH	453564194541	Whole Unit Exchange
453564156991	DCU, W/O RECORDER ENGLISH	453564156991	
453564194351	DCU, W/O RECORDER DANISH	453564194351	
453564194361	DCU, W/O RECORDER DUTCH	453564194361	
453564194371	DCU, W/O RECORDER FRENCH	453564194371	
453564194381	DCU, W/O RECORDER GERMAN	453564194381	
453564194391	DCU, W/O RECORDER ITALIAN	453564194391	
453564194401	DCU, W/O RECORDER NORWEGIAN	453564194401	
453564194411	DCU, W/O RECORDER PORT-BRAZIL	453564194411	
453564194421	DCU, W/O RECORDER PORT-PORT	453564194421	
453564194431	DCU, W/O RECORDER SPANISH	453564194431	
453564194441	DCU, W/O RECORDER SWEDISH	453564194441	





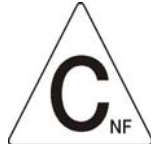







9 LIST OF SYMBOLS

The symbols defined in the list below may be found in this document or located on the shipping containers, the system, and accessories of the unit.

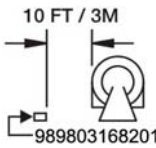
Symbol	Meaning	Symbol	Meaning	Symbol	Meaning
	Attention, Consult Accompanying Documents		Breathing Effort Detected		Non-ionizing Radiation
	Not MR Compatible		Fuse		Percent Oxygen Pulse Saturation
	Product Part Number		Earth Ground		Alternating Current
	DANGER! High Voltage		Antenna		Direct Current
	Up/Increment		Device conforms to the Medical Device Directive		Product Serial Number
	Down/ Decrement		Attention! Precautionary Alert		Locked
	Date of Manufacture		Latex-Free Materials Used		Unlocked

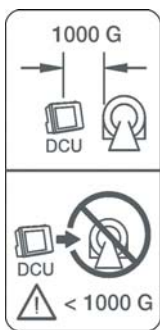
Symbol	Meaning	Symbol	Meaning	Symbol	Meaning
	Defibrillator-Proof Type CF Equipment (IEC 60601-1) Protection Against Shock		Weight		Low Battery
	Dangerous Voltage		Type CF Applied Part		Patient
	Alarms SOUND ON		Alarms SOUND OFF		Single Patient Use Only DO NOT REUSE
	Alarms ON HOLD		Alarms SILENCED		Replace Fuses As Marked
	Heart Beat Detected		Attention: Electrostatic Safety Device Observe Precautions		Battery
	Input / Output		Non-Invasive Blood Pressure		Universal Serial Bus
	Oxygen Sensor Access Here		Keyboard		ON AC Power

Symbol	Meaning	Symbol	Meaning	Symbol	Meaning
	ECG		ON Battery Power		Remote Display
	Potential restrictions for equipment including radios may apply within one or more European (EU) member states.		Serial Communications Port		Fiber Optic Temperature
	End-Tidal CO ₂ / O ₂ /Anesthetic Agents		Warning Shock Hazard		Pneumatic Respiration
	Do Not Adjust Without Referring To Service Manual		Radio Network (Wireless Modules)		Hardwire Link
	Network A		Waste Gas Output		Cardiac (ECG) Gating Output
	Network B		End-Tidal CO ₂ / O ₂ / Anesthetic Agents Input		MR Conditional
	Network C		Wheel Brake		Device conforms to the R&TTE Directive (Radio & Telecommunications Terminal Equipment)
					

Symbol	Meaning	Symbol	Meaning	Symbol	Meaning
	Network D		Underwriters Laboratories (UL) Classified Mark for the United States and Canada		Radio Network (<i>Expression</i> WPU Base to DCU)
	Network E		Dispose of in accordance with your country's requirements		I (Rotate Counter-clockwise to OPEN)
	Ensure power supply (P/N 989803169201) remains 10 feet (3 meters) or more from the MR system		Ensure power supply (P/N 989803168201) remains 10 feet (3 meters) or more from the MR system		O (Rotate Clockwise to CLOSE)
	DO NOT Move <i>Expression</i> DCU with Printer Inside 1,000 Gauss Line (as measured from the center line of the bore)		DO NOT Move <i>Expression</i> Patient Management Configuration Inside 2,000 Gauss Line (as measured from the center line of the bore)		DO NOT Move <i>Expression</i> Cart Configuration Inside 5,000 Gauss Line (as measured from the center line of the bore)
	Federal Communications Commission				



PHILIPS

