



Operation & Maintenance Manual

Original Instructions

Eliminator Van Pack 903-1315

Section 1	Introduction
Section 2	Scope of Supply
Section 3	Technical Data
Section 4	Operation
Section 5	Routine Maintenance
Section 6	Fault Finding
Section 7	Pump
Section 8	Engine
Section 9	Wiring and Circuit Diagram
Section 10	Parts List / Spares / Auxiliary components
Section 11	Service Documents
Section 12	Warranty & Certification
Section 13	Health & Safety Manual 903-1308



Read the Health and Safety Manual before operating any equipment. Failure to do so could cause serious injury or death.

Operation & Maintenance Manual for:

UNIT: Eliminator Van Pack

ISSUE DATE: 6/20

ISSUE No: 3

AMENDMENTS

Change	Changes	Date	Signature
1	NEW ADDITION	5/20	GT
2	Added Anti-Freeze System Pictures	6/20	GT
3	Updated manual to code	6/20	GT

1. Introduction

1.1. Contents



1. INTRODUCTION	3
1.1. CONTENTS	3
1.2. INTRODUCTION	6
1.3. SCOPE OF THIS MANUAL	7
1.4. THE ELIMINATOR VANPACK.....	7
1.5. COMPOSITION OF THIS MANUAL.....	8
2. SCOPE OF SUPPLY	9
2.1. SCOPE OF SUPPLY	9
2.2. VANPACK ASSEMBLY	9
2.3. DETAILED DRAWINGS	10
3. TECHNICAL DATA	14
3.1. TECHNICAL DATA	14
3.1.1. PUMP DATA.....	14
3.1.2. MAIN COMPONENTS.....	14
3.1.3. ANCILLARIES	14
3.1.4. SERVICES REQUIRED	14
3.2. TECHNICAL DESCRIPTION	15
3.2.1. PRIMARY COMPONENTS	15
3.2.2. ENGINE MONITORING	15
3.2.3. DELIVERY HOSE REEL.....	15
4. OPERATION	17
4.1. OPERATING CONDITIONS	17
4.2. DAILY CHECKS	17
4.3. PRE-START CHECKS & BLEED PROCEDURE.....	18
4.4. STARTING THE ENGINE & SETTING THE OPERATING PRESSURE	19
4.5. PRE-START CHECKS & PROCEDURES	20
4.5.1. STARTING THE ENGINE.....	20
4.5.2. CHECKING THE OPERATING PRESSURE WITH A NOZZLE FITTED	21
4.5.3. CHECKING THE OPERATING PRESSURE WITH A GUN FITTED	22
4.6. REMOTE OPERATION STARTING PROCEDURE.....	23
4.6.1. STARTING THE ENGINE.....	23
4.7. RAPID SHUTDOWN.....	25
4.8. AUTOMATIC SHUTDOWN	25

4.9. HOSE REEL WINDING AND UNWINDING	25
4.10. FROST PRECAUTIONS	26
5. ROUTINE MAINTENANCE.....	28
5.1. MAINTENANCE PROCEDURES	28
5.2. GEARBOX LUBRICATING CHART – SPECK NP25	29
5.3. GENERAL TORQUE SETTINGS.....	30
5.4. DAILY MAINTENANCE.....	31
6. FAULT FINDING	33
6.1. EQUIPMENT FAULT FINDING	35
6.2. SELECTOR FAULT FINDING.....	35
7. PUMP	36
8. ENGINE.....	37
9. CIRCUIT AND WIRING DIAGRAMS	38
10. PARTS LISTS / SPARES	42
10.1. INTRODUCTION	42
10.2. ORDERING SPARE PARTS	42
10.3. ACCESSORIES & CONSUMABLES	43
10.3.1. ROUTINE MAINTENANCE.....	43
10.3.2. CONSUMABLES	43
10.3.3. ACCESSORIES	43
10.4. PARTS LIST.....	45
10.5. HYDRAULIC DIVERTOR VALVE ASSEMBLY	51
10.5.1. RECOMMENDED TOOLS.....	51
10.5.2. SERVICE KITS.....	51
10.6. TO DISMANTLE	52
10.7. TO ASSEMBLE.....	52
11. SERVICE DOCUMENTS	57
11.1. SERVICE CHECKLIST.....	57
11.2. SERVICE LOGBOOK	58
12. WARRANTY.....	59
12.1. WARRANTY OF NEW PRODUCTS:.....	59
12.2. WARRANTY OF SPARE PARTS:.....	59
12.3. LIMITATIONS OF WARRANTY:.....	61

1.2. Introduction

Please ensure that you read this Operation & Maintenance Manual in conjunction with the Health & Safety Manual before operation.

Within this manual, the health and safety risks are highlighted with specific symbols. These will be referenced to sections within the Health and Safety Manual which you are required to read. The sections to refer to in the manual will be labelled at the end of the highlighted statement (Ex. H&S Section 2). There are three symbols that will be used to differentiate the levels of severity. They are as follows:

-  : This is the symbol for **CAUTION**. This means that if an accident were to happen, it would cause minor to moderate injury.
-  : This is the symbol for **WARNING**. This means that if an accident were to happen, it could result in a serious injury or possible death.
-  : This is the symbol for **DANGER**. This means that if an accident were to happen, it will result in death or serious injury. This will only be shown for the most extreme cases.

It is imperative that these symbols are paid attention to as to avoid any sort of injury.

Notices

Carefully read the notices of this manual because they give important information concerning safe installation, use and maintenance; familiarise yourself with the workings of the machine to rapidly switch it off and eliminate pressure.

This manual is an integral and essential part of the product; it must be consigned to the user to ensure the training/information for personnel.

The manufacturer does not assume responsibility for damage caused to persons, property or to the machine, in the case of improper use. Carefully preserve this manual for any further consultation.

Identify the model of your machine by reading the details on the identification plate. Upon delivery, inspect the machine / accessories for any damage, which may occur during transport.

CAUTION! Always follow the recommended operating procedures. Do not misuse the equipment as this could result in injury or mechanical breakdown!

1.3. Scope of this Manual

This manual provides operation and maintenance instructions for the unit. Where the unit has been fitted with proprietary components, details of these are also included in this manual.

This manual is compiled to match the Scope of Supply detailed in Section 2. All specifications, descriptions and parts lists refer only to the components in the version of the unit detailed in this scope of supply.

Maintenance instructions included in this manual include:

- Routine maintenance to be carried out at specific times.
- Maintenance of the high-pressure pump.

Repairs to the pump crankcase are not considered maintenance operations as these should be undertaken only by Harben, their approved agents, or at least competent automotive engineers.

1.4. The Eliminator Vanpack

Harben® drain vanpacks have been designed to the highest standards so that they will work safely and reliably for many years. It is important that you take time to read the information provided in this operation and maintenance manual so that you understand how to make the most of the vanpack in accordance with the instructions. Harben® vanpacks are powerful pieces of industrial equipment and should only be operated by competent users who understand that serious injury or death can occur through misuse.

The Eliminator Vanpack is a highly versatile mobile high-pressure water jetting unit, which offers the benefits of proven power pack and pump performance with a comprehensive range of accessories.

Developed for a wide range of water jetting applications, the Unit has been meticulously designed for safe and efficient use.

Additional accessories can be purchased from Harben®, such as: floor cleaners, jetting guns and jet pumps which extend the range of work that can be carried out with the jetter. Safety information relating to individual accessories is provided later in this section.

1.5. Composition of this Manual

This manual comprises the following further sections:

Section 2 Scope of Supply

This section defines the scope of supply of the equipment in compliance with the sales order.

Section 3 Technical Data

This section contains technical information about the unit.

Section 4 Operation

This section describes the recommended operating procedures for the unit.

Section 5 Routine Maintenance

This section details recommended routine maintenance requirements for the pump and unit.

Section 6 Fault Finding

Fault diagnosis tables for the pump, engine, and ancillaries.

Section 7 Pump

This section provides details of the pump and gearbox assembly.

Section 8 Engine

This section provides details about the engine.

Section 9 Circuit and Wiring Diagrams

This section includes the Hydraulic, Water and Electrical circuits including engine controller & wiring loom.

Section 10 Parts List / Spares

How to identify and order spares

Section 11 Service Documents

Service logbook and checklist.

Section 12 Warranty & Certification

Section 13 Health & Safety Manual 903-1308

This manual details health and safety considerations in general and specific to water jetting equipment.

2. Scope of Supply

2.1. Scope of Supply

Unit:	ELIMINATOR VANPACK
-------	--------------------

2.2. Vanpack Assembly

The General Arrangement drawing: 003-295, defines the components of the Eliminator Vanpack mounted Pump Assembly as follows:

Water is fed from a “mains” supply through a manual low-pressure inlet hose reel into a plastic water storage tank. The tank supplies the pump with a positive head of pressure via an inline Hypro strainer that filters the water to approximately 177 microns, (Pump is specified at 200microns)

The **Speck** high-pressure plunger pump is driven by a **Kubota D1105-E4B-EU-X1 18.5kW Stage 5 C-TXT** industrial diesel engine through a Speck NP25 gearbox.

The water is directed by an electrically controlled Hydraulic diverter valve, to a hydraulically driven hose reel c/w 300' of ½” hose, or at low pressure ‘dumped’ back to tank.

The system is protected from over pressurisation by means of a Hawk safety relief Valve. The system pressure can be adjusted by means of a Speck UL221 Unloader Valve.

The engine and system pressure can be monitored at the control panel situated at the rear of the van.

2.3. Detailed Drawings

Detailed drawings and parts lists for the above components are provided as follows:

The Speck Pump is detailed in [Section 7](#).

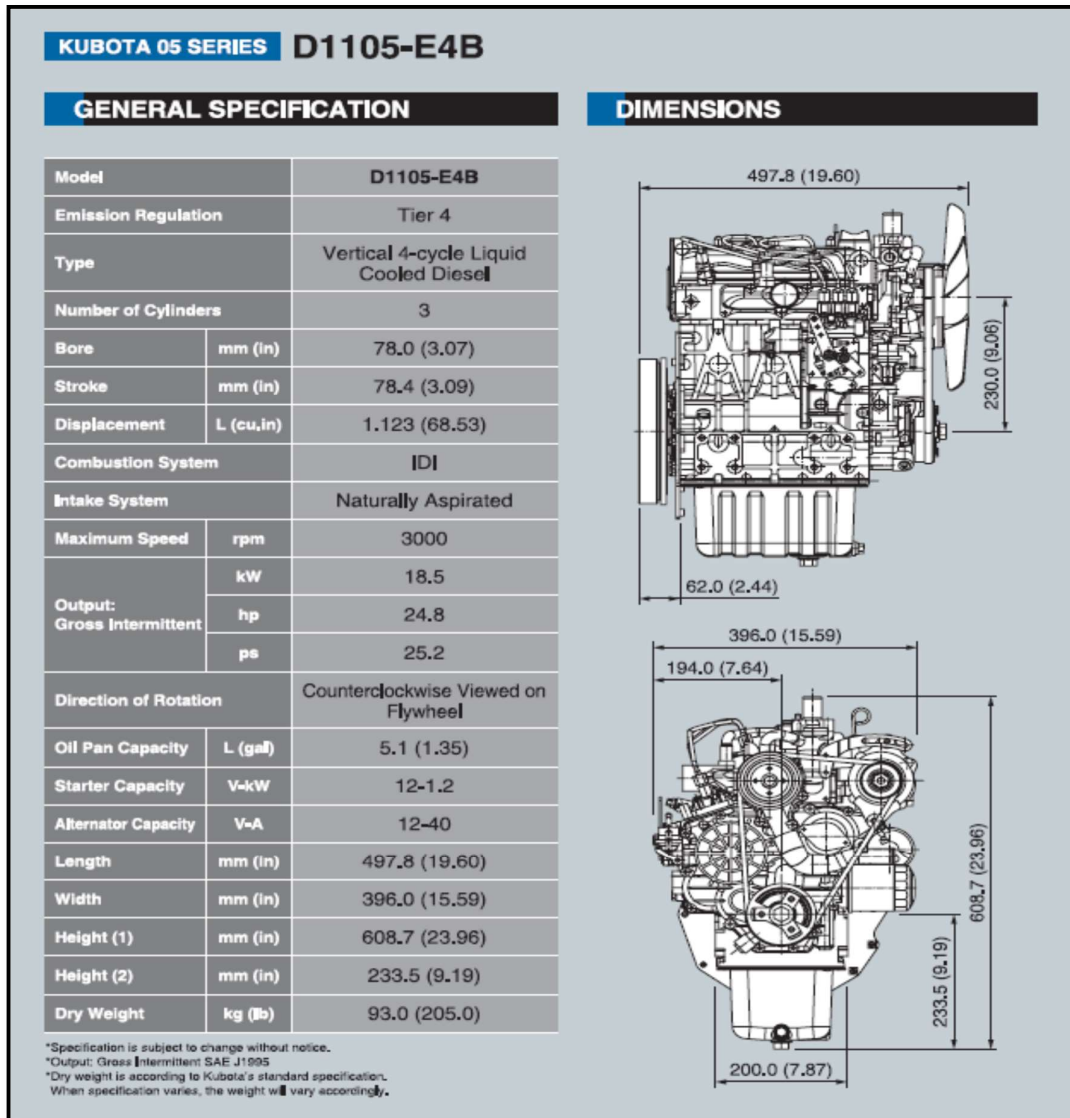

NP25 Gearbox Detail

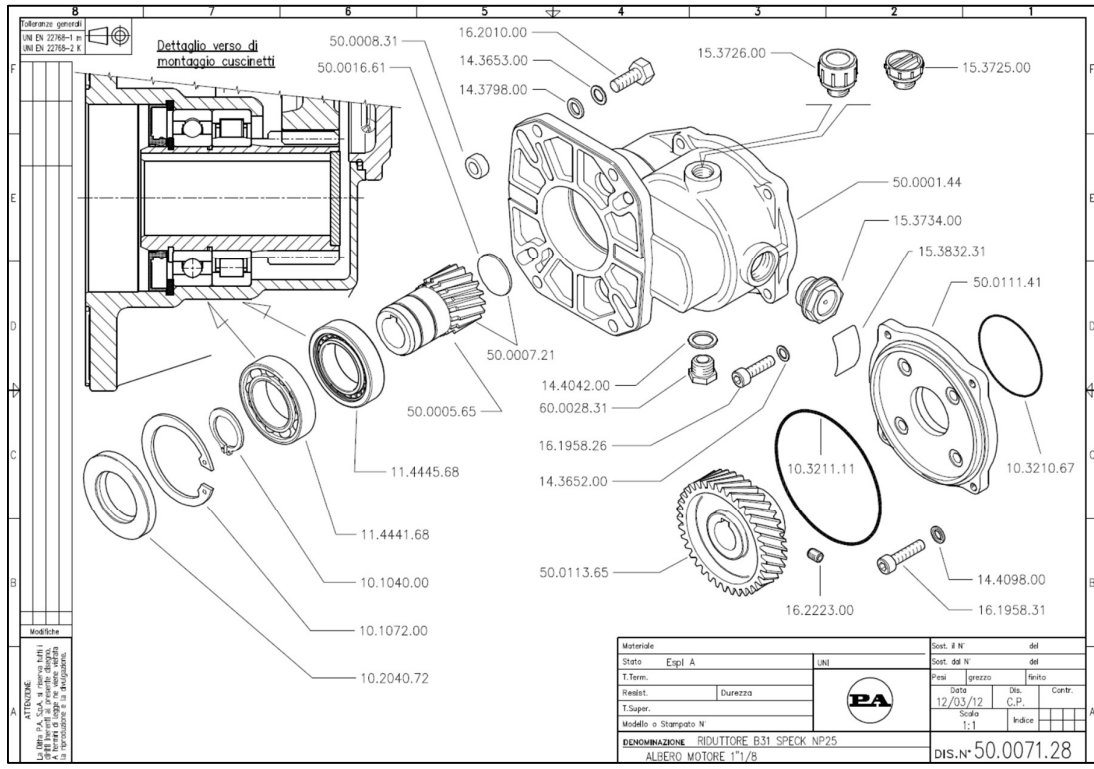

Hydraulic Diverter Valve 069-581

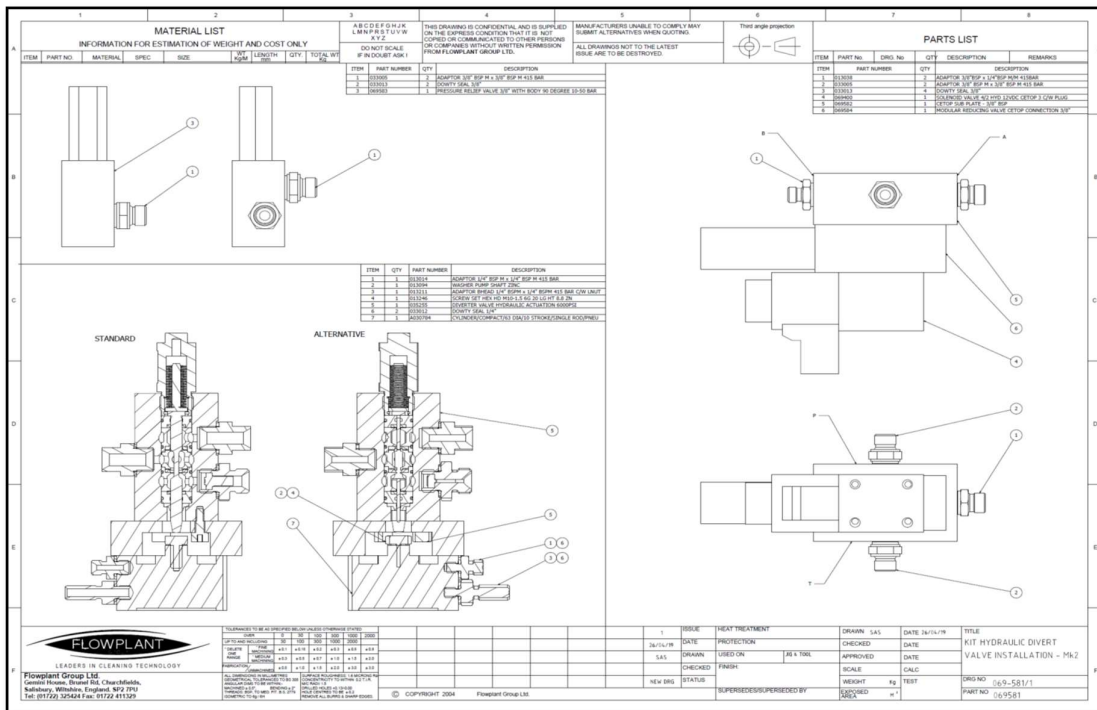

Hawk Safety Relief Valve 035-401

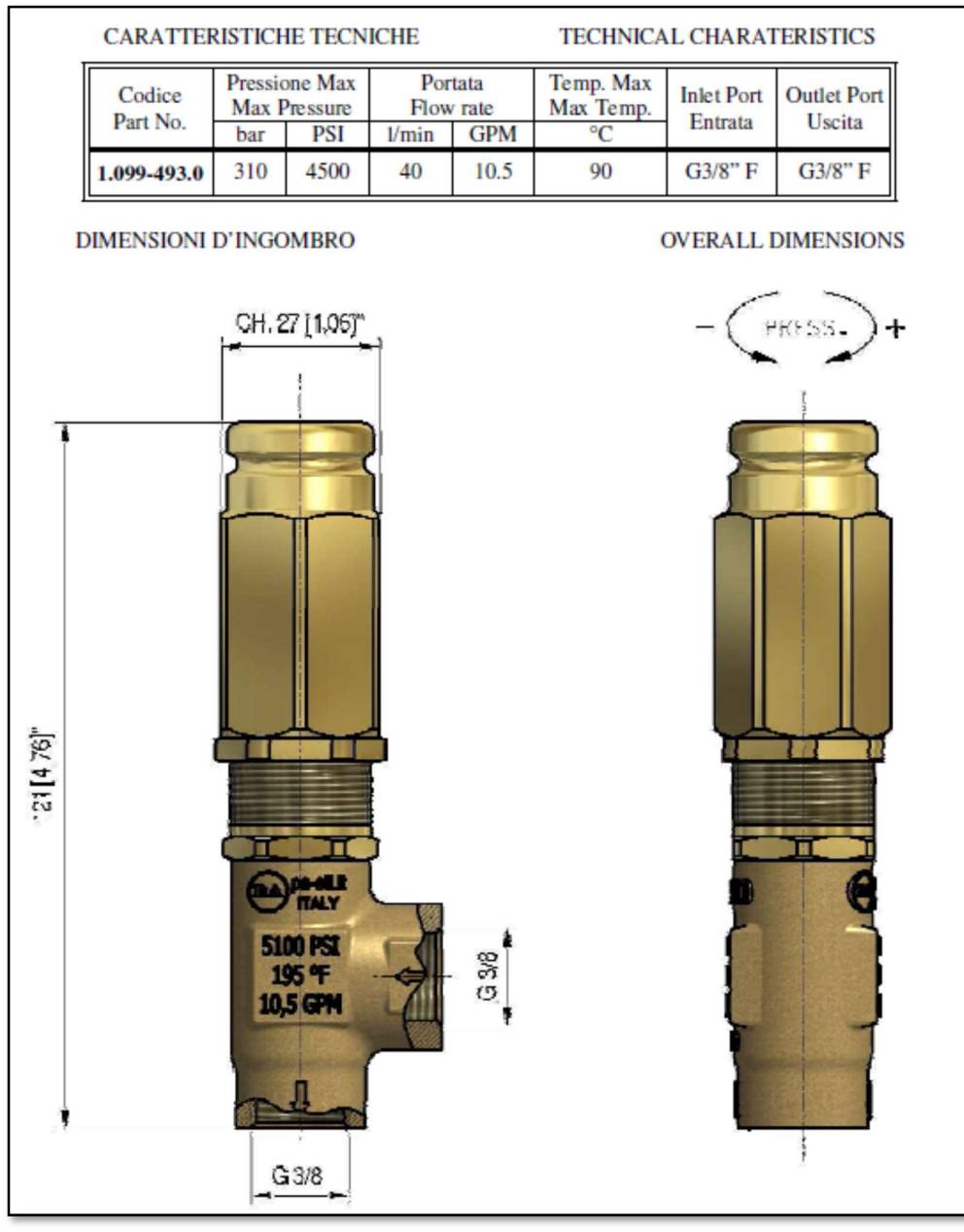

Speck Unloader Valve UL221 035-185

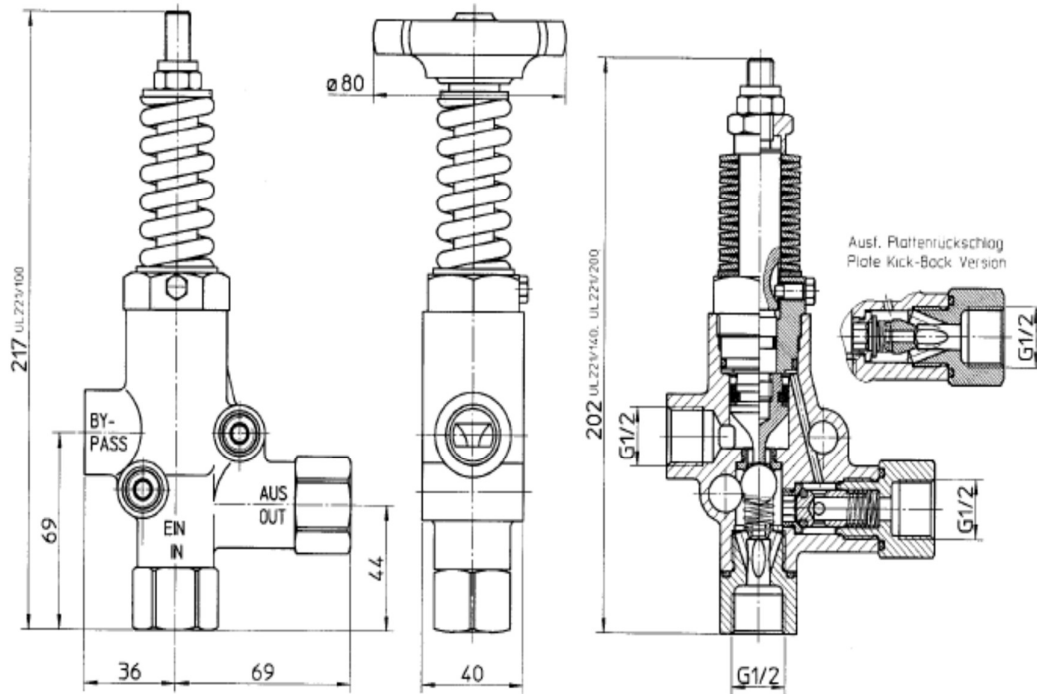

3. Technical Data

3.1. Technical Data

3.1.1. Pump Data

PUMP TYPE	Speck NP25/54-200 [positive displacement]
Number of cylinders	3
Power rating (nominal)	22.5 hp
Plunger diameter	25mm
Crankshaft speed	1450rpm
Maximum pressure	200
Normal operating pressure	200 bar [2900psi]
Flow rate	Up to 54 L/min
Crankcase lubrication	Splash / Gravity
Crankcase oil capacity	0.24 USG
Recommended crankcase oil	ISO VG 220 or SAE 90 Gear oil.
Valves	Identical suction & discharge.
NPSH	Input 10 bar max. Suction head -0.3 bar.

3.1.2. Main Components

Prime Mover	Kubota D1105-E4B-EU-X1 18.5kW Stage 5 C-TXT
Drive	Gearbox Speck NP25 Reduction box (2.176:1)

3.1.3. Ancillaries

Water Tank	Capacity 88 gals. (400 litres)
Supply Water Filter	N05105 Hypro line strainer / 177 micro mesh
Pressure Gauge	Digitally Displayed
Safety Relief	Hawk (Automatic SRV)

3.1.4. Services Required

Mains Water Supply Positive head.

Note: Water pH value of 5 to 9 is recommended.

3.2. Technical Description

3.2.1. Primary Components

The primary components of the Eliminator Vanpack are as follows:

- A prime mover in the form of a Kubota 3-cylinder water-cooled diesel engine which drives a Speck NP25 type high-pressure pump.
- The pump can raise the water pressure up to 2900psi (200 bar).
- A hydraulically driven hose reel 300 ft of 2 wire braid high-pressure hose with either a nozzle or gun attachment to deliver the high-pressure water to the selected working site.
- A plastic water tank, acting as a reservoir, ensures the water is settled and non-turbulent, discharging a smooth lamina flow of uninterrupted air free supply, a positive head of pressure to the pump inlet and maximising the pumps full potential. The tank can be filled via the inlet reel by connecting to a mains inlet water supply
 - *NOTICE: Turbulent water will cause the pump to run unevenly and cause excessive wear due to cavitation.*
- Water is diverted to the hose reel either using a 12VDC hydraulic diverter.
- A Hypro 177Micron mesh inline strainer is fitted to the suction line between the tank and the pump inlet.

Note: This is a critical component which ensures that no contaminants are drawn into the pump inlet. This filter must be inspected and cleaned daily, if it becomes blocked it will cause the pump to cavitate.

3.2.2. Engine Monitoring

Engine oil pressure and engine coolant temperature, together with alternator charge rate are continuously monitored. Activation of the engine pressure or temperature switches will cause an engine shutdown and the respective 'FAULT' to be displayed on the control unit.

Alternator failure will be displayed on the control unit.

3.2.3. Delivery Hose Reel

The hose reel drum on which the delivery hose is wound is driven by a powerful OMR315 hydraulic motor directly coupled to the hose reel hub. Hydraulic power is obtained from a hydraulic gear pump driven from the engine P.T.O. (See below)

Note: 050-324 Hydraulic gear pump detail: -

(Ratio 0.844/1.00, Output 4.35 cc/rev, direct mounting, theoretical discharge volume @ 3000rpm = 3 gpm, max speed 3200rpm, max pressure 1707psi)

The speed and direction of the reel is controlled by a manual lever-controlled spool valve c/w safety relief and flow control, this is situated just below and right of the high-pressure hose reel.

4. Operation

4.1. Operating Conditions

Operators of water jetting equipment should be fully conversant with the Water Jetting Association 'Code of Practice for the Use of High-Pressure Water Jetting Equipment', hereafter referred to as 'The Code of Practice'. A copy of The Code of Practice is available upon request.

Please ensure that you read this Operation & Maintenance Manual in conjunction with the Health & Safety Manual before operation.

4.2. Daily Checks

Carry out all daily checks. Full maintenance checks are detailed in [Section 5](#) - Routine Maintenance.

They are:

- Pump oil level
- Gearbox oil level
- Water filter cleanliness
- Engine oil level
- Engine coolant level
- Tank water level & Cleanliness
- Diesel level
- Anti-freeze level
- Radio Remote fully charged

4.3. Pre-start Checks & Bleed Procedure

1. **⚠️ WARNING!** In cold weather check that machine is not frozen before starting (see Antifreeze section 4.11). Serious injury can occur from ice bullets. **(H&S Sections 3 and 7)**
2. Only operate the machine in a well-ventilated area. **(H&S Sections 3, 8, 9, and 12)**
3. Park next to suitable clean water supply on a level ground.
4. Ensure vehicle handbrake is applied. **(H&S Sections 3, 11, and 13)**
5. To fill water tank, connect to water supply. The water will fill the tank via the inlet hose reel when the tank is full it will flow out the overflow. **(NOTICE: To comply with water authority bylaws never fill the tank by putting a hose directly inside)**
6. Feed the end of the high-pressure hose through the hose trace on the swinging arm in front of the hose reel. Do not fit the nozzle or gun at this point! **(H&S Section 3, 6, and 16)**
7. In order to avoid an interruption to the jetting operation please ensure that the hand held 'radio control unit' is fully charged, this is to ensure the radio signal is at full strength and not compromised while the unit is being operated in 'remote' mode.

NOTICE: Do not drop the handheld "radio control unit" (RCU) down a manhole as this could cause it permanent damage. Please use the lanyard provided.

4.4. Starting the Engine & Setting the Operating Pressure

The Vanpack is supplied with a Radio Control System allowing One-man operation 'OMO' in accordance with the 'Single Person Operation' as detailed in The Code of Practice.

Starting procedures are provided for 'Local' operation where water to the high-pressure hose is controlled by the operator using the Control unit at the machine, and for 'remote' operation where water to the high-pressure hose is controlled by the hand-held radio control unit 'RCU'.

While the remote-control facility is provided for single person jetting operation, it should be noted that initial pressure check **must** be made at the pump set. Hence, even with the 'remote' enabled, all initial pressure checks must be made

Either:

With a single operator and 'radio control unit' (RCU) adjacent to the pump set and with the nozzle secure in a drain or pipe or the gun firmly held in the hand.

Or:

With two people, one at the pump set and one in charge of the nozzle or gun.

Once the required operating pressure has been set, remote operation can be safely conducted by one person using the handheld 'radio control unit (RCU)

Tank water level

Ensure you have an adequate water supply and that the water tank is at least ½ full. The machine WILL NOT RUN if the water tank is empty, this will be indicated by an on-screen warning on the control panel, clearly marked as 'low water' as well as an audible warning. It is preferable to have a full tank of water and provide the pump with a good positive head.

NOTICE: Do Not allow unfiltered water into the pump

4.5. Pre-start Checks & Procedures

4.5.1. Starting the Engine



Pre-start Checks

Ensure the open-ended high-pressure hose is in a safe position, preferably within sight of the operator at the control panel.

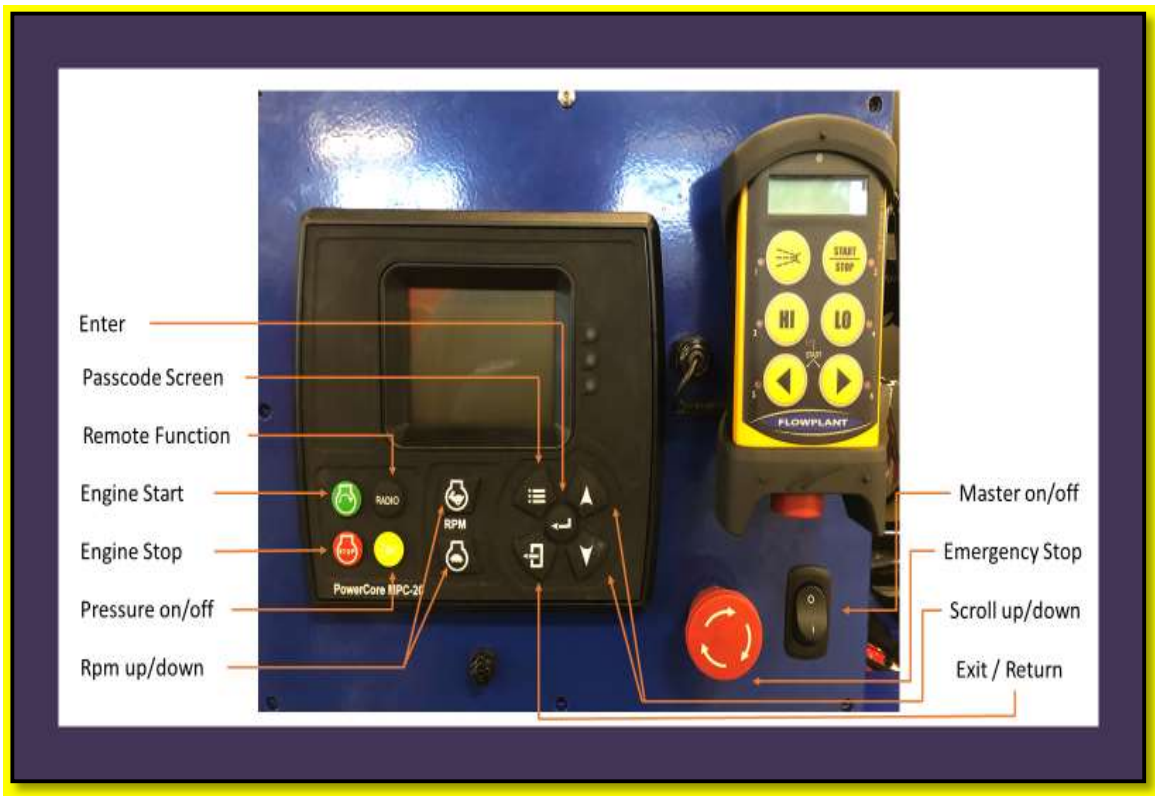
Indirect Injection Diesel Engine Key Start Module Operating Procedure



1. Rocker Switch (Bottom Right of Panel) is the Master On/Off (0)
2. In position (1) (On) auxiliary circuits will be energized, screen will be illuminated.
3. Enter the 4-digit PIN using the up and down arrows to select numbers and the enter button to select
4. Momentarily press the Green button on the Controller, this will automatically run through pre-heat and prestart When cold. Engine will start automatically and idle at a pre-determined engine rpm. **Water will now be circulating through the pump and be diverted back the water tank

5. To divert water to the High-Pressure hoses, press the water on button  on the control panel Speed / Pressure can be adjusted using RPM +  and RPM -  buttons.
6. Use the "Hare" button to raise the RPM and in-turn raise the water pressure
7. To shut the system down, reduce the RPM to idle speed and turn off the water. Switch the engine off by momentarily pressing the red button. The engine will shut down safely. Switch the master switch to 0. The system is now safely off.
8. In emergency situations press the stop button on the radio control panel or the emergency stop button on the main control panel.

If the engine is already warm the same process will be followed. The system shutdowns are automatically overridden in the initial sequence to allow to engine oil pressure to stabilise.

4.5.2. Checking the Operating Pressure with a Nozzle Fitted

1. Fit the correctly sized nozzle to the high-pressure hose.
2. Ensure the nozzle is secured in a safe position, preferably within sight of the operator at the control panel.
3. Press the water 'ON' button  at the control panel. Select the required speed.
4. Observe the pressure displayed on the control panel screen and note the pressure reading (See Fig. 3). Press the water 'off' button and select idle. Note: If the pressure is significantly lower than expected, turn the unit off and replace the nozzle with a new one.

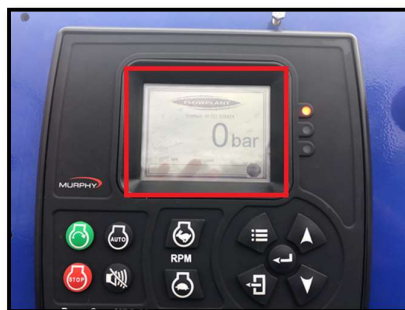





Fig 3 Pressure Gauge Display

NOTICE: Do not exceed the maximum operating pressure of 2900 psi by fitting a smaller nozzle than is recommended, as this will cause the Pressure relief valve & or Safety relief valve to dump the excess pressure. The maximum engine speed is mechanically governed to 3150 rpm.

4.5.3. Checking the Operating Pressure with a Gun Fitted

1. Fit the gun (with the appropriately sized H.V. (pencil) or Fan Jet), to the high-pressure hose.
2. **⚠ WARNING!** Ensure the gun is held firmly in the hand. If the operator loses control of the gun, it can hit someone and cause serious injury. **(H&S Section 3 and 15)**
3. Start the engine.
4. Press the  button to divert the water to the gun. Use the  button to raise the engine speed.
5. Pull the gun trigger and observe the pressure gauge mounted on the instrument panel, note the pressure reading (See Fig. 3). Press the  button until engine tick over speed is reached, then press the 'water off' button and return the unit to the idle position

Note: If the pressure is significantly lower than expected, turn the unit off and replace the worn nozzle in the gun with a new one!

When using the RCU the operator is required to remove the key from the Local/Remote selection whenever the trailer/van pack is unattended.

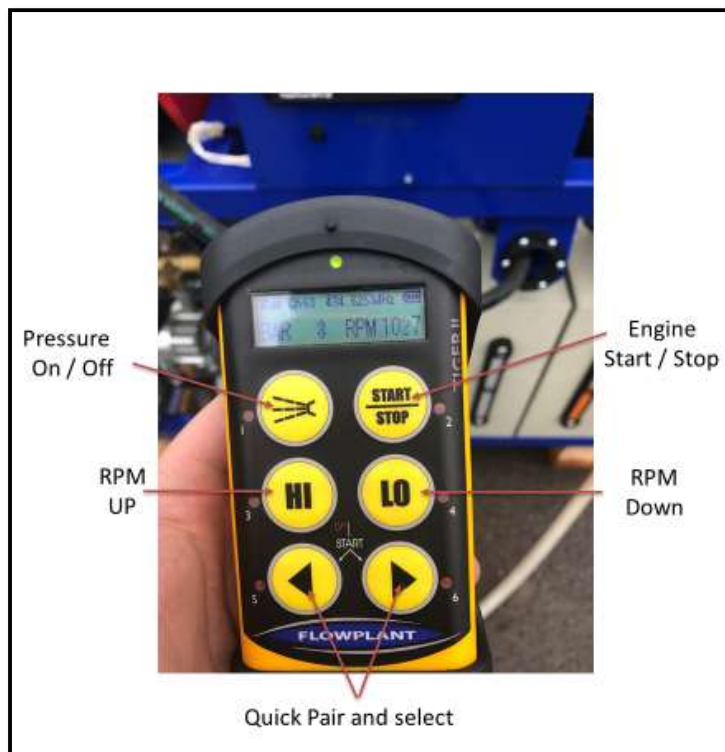









Fig 4. Operating with the Radio Remote

4.6. Remote Operation Starting Procedure

4.6.1. Starting the Engine

1. Switch on the Panel using the I/O Rocker switch. (See Fig. 2)
2. Enter the PIN using the  &  Arrows and  buttons on the controller.
3. Press the remote function on the controller (See Fig. 2) press  to enable remote. Display will show "Remote enabled" the unit is now ready for remote control.

On the RCU:

1. Pull out red button on the base of the RCU to switch the handset on.
2. Follow the on-screen instructions - Press and hold fully down both buttons 5 + 6 for 3 seconds, a beeping noise will emit from the RCU. RCU & receiver have now 'paired'. (See Fig. 5)
3. Press button 2, the Start / Stop button on the RCU 
4. To increase engine speed, press the 'engine speed up' button, this is indicated by the symbol of a hare. (See Fig. 5)
5. To decrease engine speed, press the red engine 'speed down' button, this is indicated by the symbol of a tortoise. (See Fig. 5)
6. Press button 1, the water ON button, to divert the water to the nozzle or gun. 
(See Fig. 5)
7. Press button 1 again, this will now divert the water back to tank. (See Fig. 5) 
8. To stop the engine, reduce the Engine rpm press button 2 the start / stop button on the RCU. (See Fig. 5) 
9. The Remote-control unit will remain connected unless the user disables remote control function at the main controller or system is powered down.



When the engine has been stopped the RCU will turn itself off. To resume return to step 5.

If the operator goes out of radio receiving range the system will automatically turn the water OFF (divert back to tank). When the operator steps back into radio receiving range, the status is healthy, and jetting can be resumed.



Fig. 5 Handheld RADIO Control Unit (RCU)

Remote

- **Button 1** - Water on / Water Off. 
- **Button 2** - Engine Start Stop 
- **Button 3** – HI (RPM Up)
- **Button 4** - LO (RPM Down)
- **Buttons 5&6** – Start Up
- **No Lights** - RCU off.
- **Charging** - See handbook for charging instructions

Turning the unit ON

- Pull out the red button at the base of the RCU
- Press both buttons 5 & 6 together and hold for at least 3 seconds until a beep is heard. Once connected, the screen should display as per Fig. 5

Turning the remote control OFF

- Turn the handset off by pressing the red STOP button

4.7. Rapid Shutdown

Should any unforeseen circumstances arise, including any signs of a leak, the jetting operation should be terminated immediately, the equipment shut down, and the relevant managers informed.

4.8. Automatic Shutdown

The engine will shut down automatically if the monitoring and control system detects a malfunction. Possible reasons for an automatic shutdown are detailed in [Section 6](#) - Fault Finding.

4.9. Hose Reel Winding and Unwinding

The high-pressure hose is manually unwound and hydraulically wound by an OMR315 hydraulic motor, which is driven by a gear pump from the engine P.T.O. **(H&S Section 6)**

The motor is fitted to the hub of the hose reel. The motor speed and direction are controlled via a manually actuated spool valve. (018-005 "Hydraulic Directional Control Valve" CV1185 c/w 90- 100psi relief and flow control)

The hose reel motor speed can be adjusted up and down by a flow control knob. Pushing the lever inwards towards the pump set will wind the hose reel in.

The normal practice is to unwind the hose by hand, only drawing off the required length of hose to reach the work site and then to wind the hose back in using the hydraulic motor.

It should be remembered that the hose cannot be wound using the hydraulic motor unless the engine is running. Therefore, when a jetting operation is finished, wind in the hose before shutting down the engine. Wind in the hose before you intend to empty the tank.

⚠ CAUTION! If the hose becomes stuck in the drain the hydraulic hose reel should NOT be used as a winch to try and free it and the towing vehicle should NEVER be driven away to drag the hose clear. This will put severe strain on the reel framework which could lead to serious damage. **(H&S Section 3, 6, and 13)**

Hoses that have become stuck can sometimes be pulsed free using the Jump Jet kit or alternatively they should be pulled free by hand.

NOTICE: The hose should NEVER be tightly wound onto the hose reel drum when the hose is not pressurised, as might occur when the hose has become trapped. A tightly wound hose can easily crush the hose reel when it is next pressurised. If you have reason to believe that the hose may have been tightly wound onto the reel when unpressurised it should be completely unwound and then rewound loosely before pressurising.

4.10. Frost Precautions

During periods when there is a risk of freezing the following precautions should be taken:



1. Prepare 50% anti-freeze solution.
2. Remove nozzle or gun attachments from the delivery hose.
3. Lower the water level in the tank.
4. Fill the anti-freeze tank to maximum with the 50% solution.
5. Move the T-Port valve in the suction line to the upwards towards the antifreeze position and remove the lid from the Anti-freeze tank.
6. Ensure you hold the end of the jetting hose firmly in your hand.
Start the engine and immediately press the water on button. Water will exit the hose instantly & the level on the antifreeze will begin to decrease rapidly.
When the water runs blue insert the end of the hose into the Antifreeze tank.
7. Allow the antifreeze to circulate for a minimum of 30 seconds.
8. Operate the jump jet kit for a few seconds to antifreeze the jump jet circuit
9. Quickly fully unwind the unloader to protect these lines.
10. As soon as it is fully unwound. Shut down the engine.
11. Select freewheel on the hydraulic lever Manually rewind the hose reel.
12. Secure the hose end in the correct place on the frame.
13. Ensure the hydraulic valve is taken out of the freewheel position.

14. Replace the antifreeze tank lid.

15. Isolate the machine.

NOTICE: If the pump is frozen up – it should on no account be started. Operating the machine frozen will damage the pump and damages caused by misuse will not be covered under warranty.

DO NOT ATTEMPT TO JET ANY REMAINING ANTIFREEZE SOLUTION INTO A CONTAINER

5. Routine Maintenance

Table 5.1 provides a basic guide to routine maintenance requirements for the various components of the trailer.

Warning: Maintenance should only be carried out with the engine turned off and when cold.

5.1. Maintenance Procedures

Table 1 indicates recommended routine maintenance tasks cross referenced to maintenance procedures.

	GENERAL
Prior to use / Daily / after 8 hours running	<ul style="list-style-type: none"> • Check inlet water filter element (Clean if necessary) • Check engine oil level on dip stick • Check engine coolant level • Visual check for hose damage/water leaks & for any cracks in frame/chassis etc. • Check Power and remote control • Check emergency stop button operation (Ref para 4.4)
Weekly / 24 hours	<ul style="list-style-type: none"> • Visually inspect van pack for security checking for any loose, damaged, or missing parts. • Check for any leakage • Check air filter cleanliness • Check engine fuel water trap for contamination
Three monthly / 50 hours	<ul style="list-style-type: none"> • First service contact Harben Service
Six Monthly / 100 hours	<ul style="list-style-type: none"> • Inspect tanks and fittings for leaks, thoroughly clean & flush through • Tighten any loose joints • Grease the hydraulic hose reel bearing blocks • Check condition of 12volt start battery • Grease battery terminals for protection • Check alternator belt
Yearly / 300 hours	<ul style="list-style-type: none"> • Intermediate service of engine, gearbox and pump required (Contact Harben) • Closely inspect the structural integrity of the framework for signs of stress and cracking (Specifically welded joints) • Check hydraulic filter gauge. If it reads in the red replace the filter and oil (Shell Tellus 22) • Carry out detailed inspection of pipes, hoses, and fittings. (Specifically looking for perished rubber and damage)
Two Yearly / 400 hours	<ul style="list-style-type: none"> • Major service of engine, gearbox and pump required (Contact Harben) • Check wiring terminals/connections and continuity of electrical earth.
Two Yearly / 600 hours	<ul style="list-style-type: none"> • Major service of engine, gearbox and pump required (Contact Harben) • Replace pump inlet/delivery valves • Check wiring terminals/connections and continuity of electrical earth.

For a detailed guide to pump maintenance and overhaul procedures refer to [Section 7](#).

For a detailed guide to engine maintenance and overhaul procedures refer to [Section 8](#).

For routine engine maintenance please refer to the engine handbook supplied with the unit.

5.2. Gearbox Lubricating Chart – Speck NP25

Always use the sight glass in the side of the gearbox as the level indicator

Manufacturer	Type	Oil Capacity (litres)	
		Output shaft Above Input	Input shaft Above Output
ESSO	Nuto H15	0.65	0.50
GULF			
MOBIL	DTE 11		
ROC			
TEXACO			
BP	Energol SHF LT15		
AGIP			
SHELL	Tellus T15		
CENTURY OIL	Nevis No5		
PETROFINA			
CASTROL	Hyspin AWH 15		

5.3. General Torque Settings

Fastener Nominal Dia (mm)	TORQUE SETTING (Nm)				
	Carbon Steel			Stainless Steel	
	Grade 8.8	Grade 10.9	Grade 12.9	Grade A2.5	Grade A2.7
5	6	8	10	4	6
6	11	14	16	7	10
8	27	33	40	17	23
10	53	66	79	33	46
12	92	115	138	58	81
16	229	286	344	143	200
20	447	559	670	279	391

The above Torque settings are for lightly oiled threads. IMPORTANT! DO NOT USE for DRY THREADS. ALL THREADS MUST BE LIGHTLY OILED, unless specified otherwise.

Where the nut material is softer than the bolt, this **must** be considered, and a lower torque figure calculated. (Contact: Technical Dept).

The above Torque settings are to be used when no other specific torque is quoted. ALWAYS CHECK if a specific torque figure is available.

5.4. Daily Maintenance

The following must be completed daily with the unit switched **OFF**. (H&S Section 11)

1. Check condition of inlet water filter & element. Clean or replace. (Harben part no. N05105)



Unscrew the bowl to remove the mesh (Harben part no. N06021). Take precautions so as not to lose the sealing ring (Harben part no. N05108).



-
2. Visually inspect all hoses for signs of chaffing or leaks. Report any damage immediately to supervisor or manager.
 3.  **WARNING!** Water at high-pressure jetting from a damaged hose or hose connector can cause serious injury. Do not attempt to repair or secure any hose while the high-pressure pump is running. **(H&S Sections 3 and 6)**

With the machine running:

4. Make further inspection for leaks. If a leak is observed, shut down immediately and report the leak to a supervisor or manager.



6. Fault Finding

Most of the problems experienced during jetting operations are likely to be caused by the Inlet water filter pump or the associated hoses.

These types of problems are covered in the pump fault finding chart, which is repeated overleaf for convenience.

Also covered overleaf is a diagnosis of selector valve problems.

The table below indicates potential problems and suggests an appropriate course of action.

Lamps	Condition	Solution
	<p>Low oil pressure shutdown.</p>	<p>Check oil level & top up if necessary.</p> <p>Check and replace switch if faulty.</p> <p>Check the oil pressure if the pressure is low</p> <p>Refer to the handbook for further advice.</p>
	<p>Water/coolant temperature shutdown.</p>	<p>Check Coolant level & content top up if necessary</p> <p>Check and replace switch if faulty.</p> <p>Check the water temp in the radiator, if the temp is abnormally hot, Refer to the engine handbook for further advice.</p>
	<p>Emergency stop button in</p>	<p>Twist to release the button.</p> <p>Note: The engine will not start in this condition, do not continue to crank the engine, as this will damage the starter due to over cranking!</p>

	<p>Charge warning indication</p>	<p>Check the alternator 'V' belt tension, tighten the belt if it is slack and slipping.</p> <p>Check the connecting terminals to the alternator.</p> <p>Check the engine idle speed, reset if necessary.</p> <p>Refer to engine handbook for further advice.</p>
--	---	--

6.1. Equipment Fault Finding

Problem	Possible Cause	Recommended Action
Low system pressure	Worn or incorrectly sized nozzle. Blocked water filter. Blocked suction hose. Damaged suction hose. Leaks in delivery hoses/couplings. Unloader valve leaking. Worn pressure packings. Worn suction or delivery valves.	Replace nozzle. Clean filter element. Remove obstruction. Repair or replace. Check all joints for tightness. Replace any worn hoses. Repair or replace. Replace worn parts. Replace seals or renew valves.
Low pressure and pump pulsing	Broken valve spring. Leaking O-ring on valve cartridge. Worn pressure packings.	Replace spring. Renew O-rings. Renew packings.
Excessive water leakage from pump	Worn pressure packings. Scored plungers.	Renew packings. Replace plungers.
Water in crankcase	Filler/breather cap missing. High humidity.	Replace cap. Replace oil and reduce oil change interval.
Noisy operation	Worn bearings.	Overhaul or replace pump.
Oil Leaks	Worn pressure packings. Worn oil seals.	Renew packings. Replace oil seals.

6.2. Selector Fault Finding

Selector problem	Cause	Action
Loss of pressure and flow is down.	Water leaking through the worn seat back to tank.	Replace the seats and the plug if also damaged.
If water leaks along spindle and past lever.	O-ring and back up ring failure along shaft.	Replace O-ring and back up ring 013-021 & 023-001.
Water leaking along the gland nut thread.	Leaking selector seal.	Replace seal 012-095.

7. Pump

Harben offer a detailed manual with the Speck NP25/54-200 Pump and this will be accompanied by this manual.



8. Engine

Kubota offer a detailed manual with the **Kubota D1105-E4B-EU-X1 18.5kW Stage 5 C-TXT** engine and this will be accompanied by this manual.

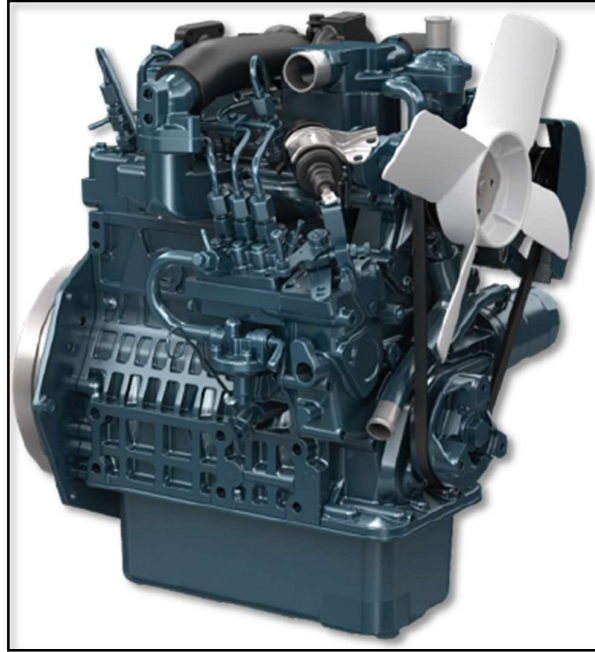

Basic engine noise levels

Engine RPM	1500	2000	3000
AT 1 METER FULL LOAD db (A)	84	87	94
AT 7 METER FULL LOAD db (A)	67		77

Replacement filters may be obtained from Harben

Harben PART No.	ITEM
051-1057	ENGINE OIL FILTER
051-1058	ENGINE FUEL FILTER
051-1059	ENGINE AIR FILTER
054-020	ENGINE OIL
054-047	GEARBOX OIL
054-047	PUMP OIL

9. Circuit and Wiring Diagrams

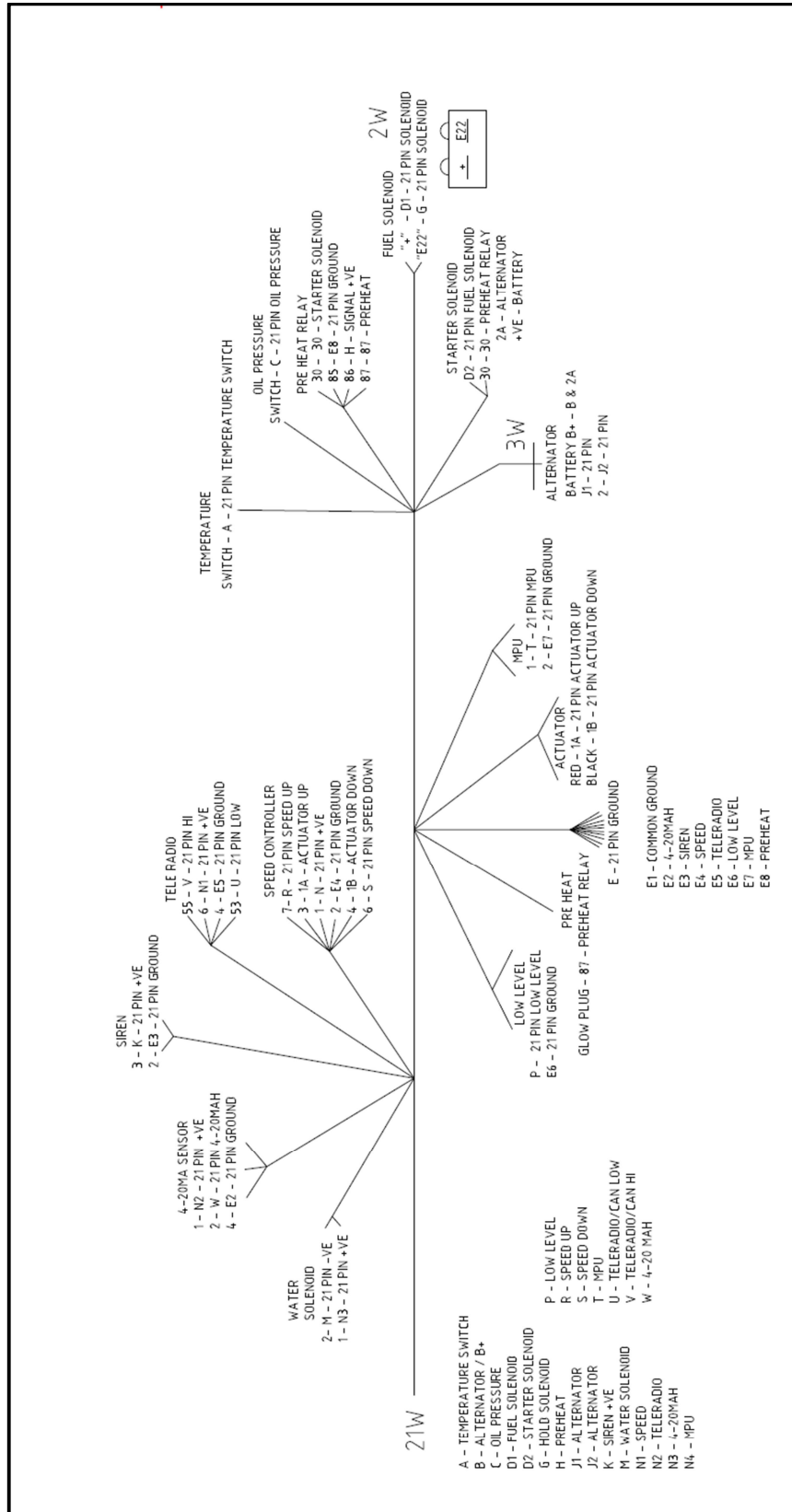

P00486		Kubota									
Wire No.	Colour	DIBs	Dia (mm)	Length (mm)	Start Point		Application	End Point		Colour	
					Termination/Crimp	Connector		Termination/Crimp	Connector		
A	White	051-5008	1.5	2900	A - 21W (031-1001)	21 Way 031-1066	Temp	Red Female Spade	023-4003		
B	Brown	051-6003	2.5	2400	B - 21W (031-1011)		Alternator	Blue 8mm Ring	023-5012		
C	Orange	051-5005	1.5	2400	C - 21W (031-1001)		Oil Pressure	Blue 5mm Ring	023-5003		
D1	White/Red	051-5011	1.5	3000	D - 21W (031-1011)		Fuel Solenoid	6189-0264	2W		
D2	White/Red	051-5011	1.5	2300			Starter	Blue Female Spade	023-4004		
G	White/Violet	051-5013	1.5	3000	G - 21W (031-1011)		Fuel Solenoid	6189-0264	2W		
H	Black	051-5002	1.5	2150	H - 21W (031-1001)		PreHeat Rly	85 - Blue Female Spade	023-4004		
J1	Brown/Yellow	051-5022	1.0	2250	J - 21W (031-1001)		Pin 1 of 3Way via PCB B6699		023-4110		
J2	Brown/Yellow	051-5022	1.0	550			Solder at Joint and crimp to pin 2 of 3way		023-4110		
K	Red	051-4006	1.0	2450	K - 21W (031-1001)		Siren +	Rd Ferrule	023-3002		
M	White	051-5008	1.5	2350	M - 21W (031-1001)		Water -	Blk Ferrule	023-3004		
P	Green/Brown	051-5021	1.5	2500	P - 21W (031-1001)		Low Level	Red Female Bullet	023-4300		
R	White/Black	051-5031	1.0	1300	R - 21W (031-1001)		Speed Up	Red Female Spade	023-4003		
S	White/Blue	051-5032	1.0	1300	S - 21W (031-1001)		Speed Down	Red Female Spade	023-4003		
T	Violet	051-5007	1.5	2500	T - 21W (031-1001)		MPU	Red Female Spade	023-4003		
U	Green	051-2010	0.5	1600	U - 21W (031-1001)		TeleRadio/CanLow	Blk Ferrule	023-3004		
V	Yellow	051-2009	0.5	1600	V - 21W (031-1001)		TeleRadio/CanHi	Rd Ferrule	023-3002		
W	Grey	051-4004	1.0	2450	W - 21W (031-1001)		4-20MA	Rd Ferrule	023-3002		
E	Black	051-5002	1.5	1650	E - 21W (031-1011)		Com Ground -	Com Ground -	023-7024		
E3	Black	051-4002	1.0	2650	Blk Ferrule		Siren -		023-7024		
E4	Black	051-4002	1.0	1500	Red Female Spade		Speed -		023-7024		
E5	Black	051-4002	1.0	1800	Blk Ferrule	Tele -	023-7024				
E6	Black	051-4002	1.0	2000	Red Male Bullet	Low Level -	023-7024				
E7	Black	051-4002	1.0	2000	Red Female Spade	MPU -	023-7024				
E8	Black	051-4002	1.0	1650	Red Female Spade	86 -Pre Heat Rly -	023-4003				
N	Red	051-4006	1.0	1300	N - 21W (031-1001)	Speed +	Red Female Spade		023-4003		
N1	Red	051-4006	1.0	1600		TeleRadio +	Rd Ferrule	023-3002			
N2	Red	051-4006	1.0	1750		4-20mA +	Rd Ferrule	023-3002			
N3	Red	051-4006	1.0	2150	Soldered to N1 at Joint	Water +	Via 5AFuse/Blk Ferrule	023-3004			
1A	White/Black	051-5031	1.0	1850	Red Male Bullet	023-4301	Actuator Up	Blue Female Spade	023-4004		
1B	White/Blue	051-5032	1.0	1850	Red Male Bullet	023-4301	Actuator Down	Blue Female Spade	023-4004		
87	Red	051-5006	1.5	2350	Blue 8mm Ring	023-5012	Pre-Heat Rly	Blue 8mm Ring	023-5012		
	Loose Supply	(Starter Solenoid)									
30	Yellow	051-5009	1.5	700	Blue Female Spade	023-4004	Starter/Pre-Heat	Blue 8mm Ring	023-5012		
2A	Red	051-5006	1.5	950	Blue 8mm Ring	023-5012	Starter/Alt	Blue 8mm Ring	023-5012		

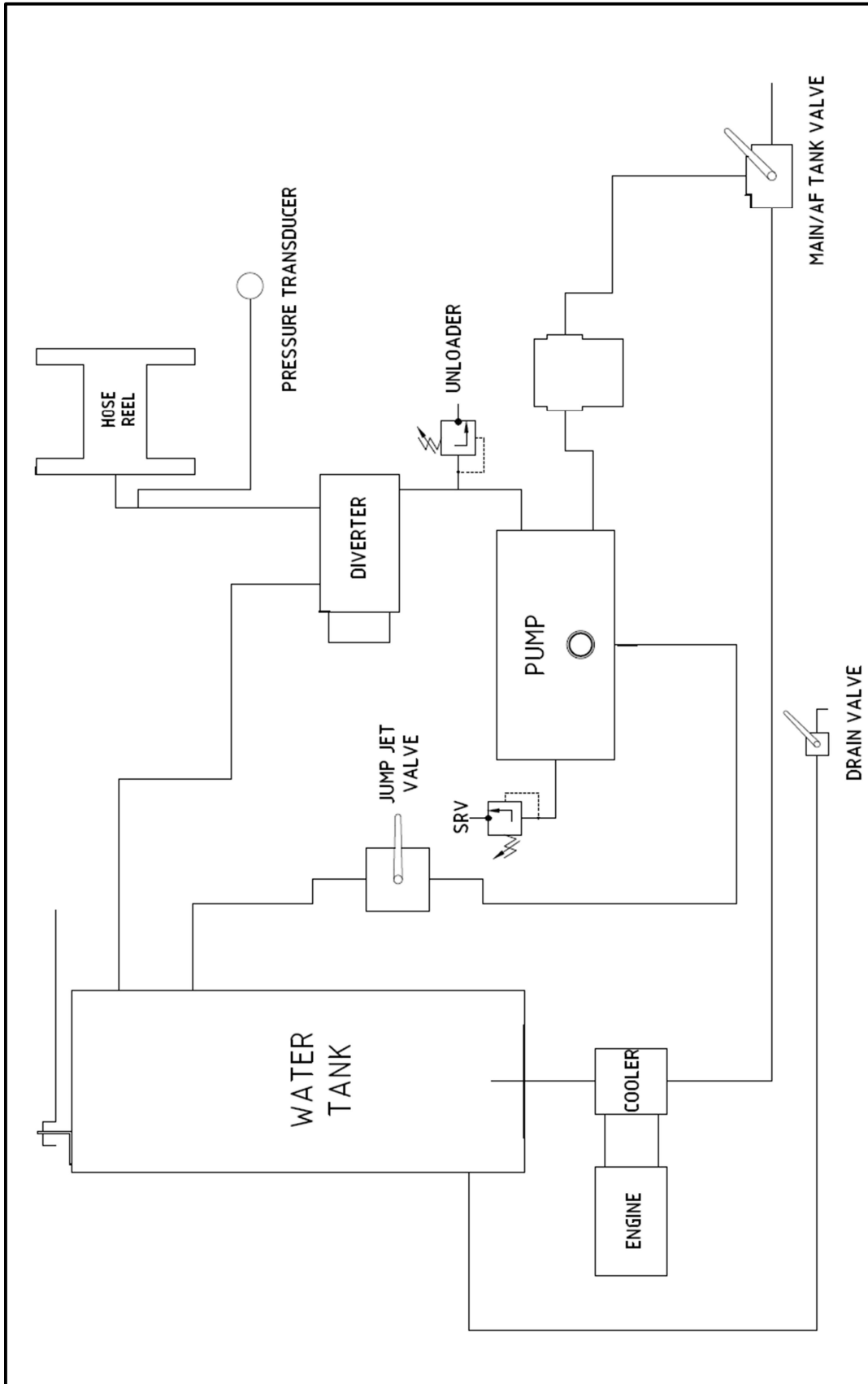

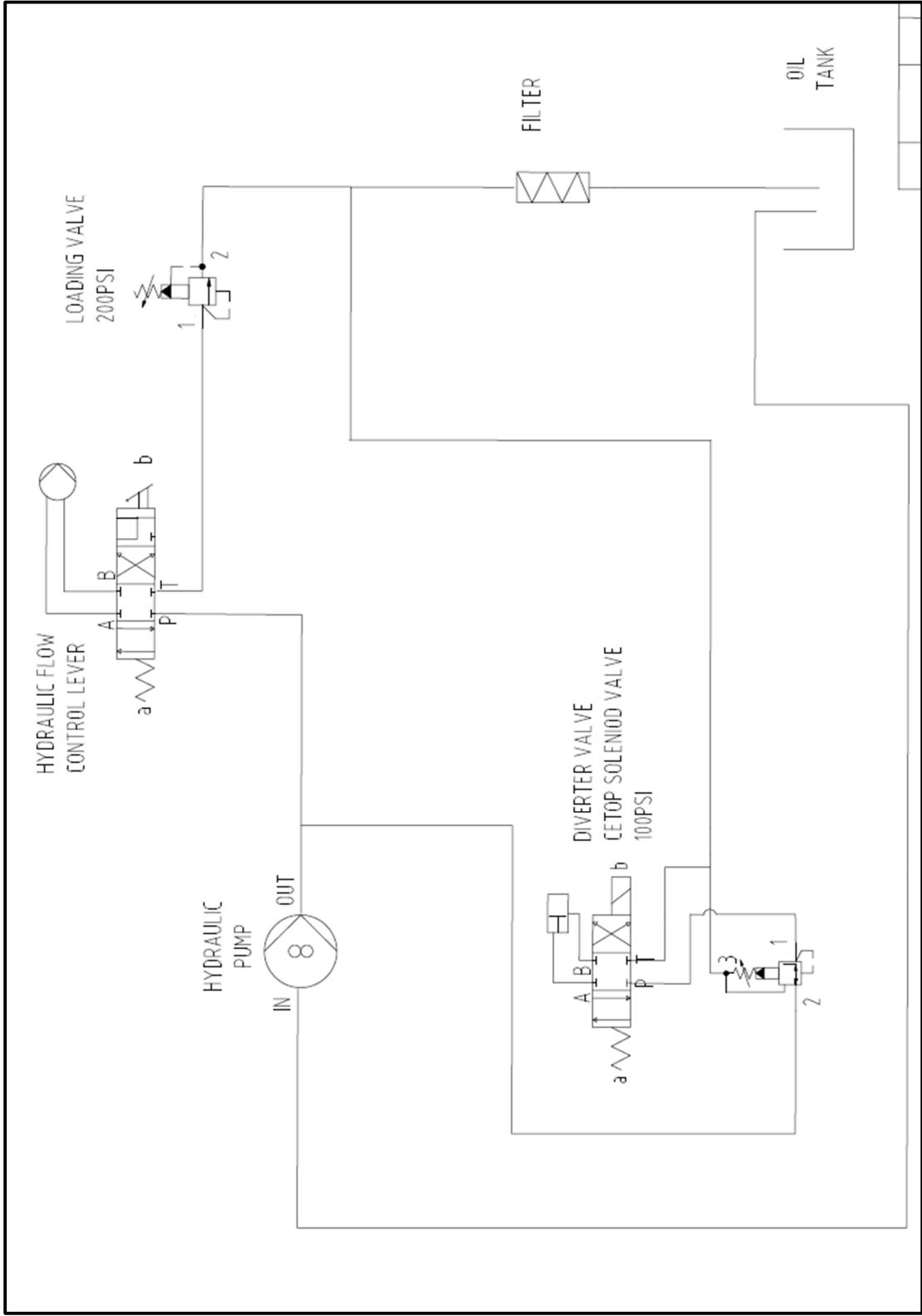

10. Parts Lists / Spares

10.1. Introduction

This section includes advice on obtaining spare parts.

To identify consumable items and service kits you require you should use the information in this section. To identify components for the pump or engine etc, refer to the relevant parts in this manual.

10.2. Ordering Spare Parts

Order spare parts from:



Harben Inc.

2010 Ronald Reagan Blvd.

Cumming GA 30041

Tel. (770) 889-9535 - Fax. (770) 887-9411

email: sales@harben.com

www.harben.com

10.3. Accessories & Consumables

10.3.1. Routine Maintenance

For routine maintenance, the following will be required.

10.3.2. Consumables

N0621 MESH FOR LINE STRAINER N015108 177 MICRON

011-046 PRESSURE DISC WHITE 4000psi

10.3.3. Accessories

Ancillary Equipment

055-021 HOSE ASSY 1/2" 91.44M STR/STR 1/2"BSPF DIN 20022 2SN

Guns/Lance

031-040 GUN MARK 2 SAFETY 6000 PSI (OPTIONAL)

Jet Inserts

056-026 JET HIGH VELOCITY 2.1MM

056-180 JET FAN 15 DEGREE 15125 1/4 NPT S/S

General Accessories

056-097 JET DRAIN 1/2"BSP 3 x 1.0MM @ 30 DEGREES

056-413 JET DRAIN 1/2"BSP 3Rx1FWD DIAMETER 1.0 at 30 DEG

056-584 JET DRAIN 1/2" BSPM 6R X 0.8MM @ 30DEG HARBEN

013-290 PRESSURE GAUGE 10,000 PSI

055-093 HOSE ASSY LEADER 1/2"BSPM 1/2"BSPF 3.05M SAE100R8

023-227 MINI JET KIT 20'COMPLETE MAX. W.P. 6000 PSI

060-133 JET DRAIN H/E 6 x 0.8MM REAR

056-671 JET HE 1/2" 3 REAR x 0.8, 0.9 FWD

ITEM	HARBEN PART NO	DESCRIPTION	QTY	CODE
1	051-1057	Engine Oil Filter	1	SSP
2	051-1058	Engine Fuel Filter	1	SSP
3	051-1059	Engine Air Filter	1	SSP
4	051-1060	Engine Water Temp Switch	1	SSP
5	051-1061	Engine Oil Pressure Switch	1	SSP
6	051-1065	Alternator Fan Belt	1	SSP
7	054-020	Engine Oil	5.1 L	SSP
8	054-047	Gearbox Oil	0.35 L	SSP
9	054-047	Pump Oil	0.9 L	SSP
10	054-111	Antifreeze Solution	2.0 L	SSP
11	023-011	Angle Swivel Joint 90 deg	1	RSP
12	035-235	3/8" Ball Valve	1	RSP
13	035-185	Unloader Valve UL221/200H	1	RSP
14	035-401	Safety Relief Valve	1	RSP
15	042-3315	320 Murphy Control Panel	1	RSP
16	067-853	Gearbox 2.176:1 Speck NP25	1	RSP
17	071-1240	Teleradio Control System	1	RSP
18	TBC	Transmitter	1	RSP
19	TBC	Receiver	1	RSP
20	071-1242	Pressure Transmitter (Transducer)	1	RSP
21	071-1392	Magnetic Pick-up	1	RSP
22	071-1408	Rocker Switch On/Off Switch	1	RSP
23	071-272	Heavy Duty Battery	1	RSP
24	071-367	E-Stop Twist to Release	1	RSP
25	071-786	Relay 12v 120amp	1	RSP
26	071-886	Float Switch Horizontal 1/2" NPT	1	RSP
27	071-901	Electrical Piston	1	RSP
28	071-902	Electrical Control Unit	1	RSP
29	078-393	Cable Grip Holder	1	RSP
30	N05-105	Line Strainer 1 1/4"	1	RSP
31	N06-021	Line Strainer Element	1	RSP
32	N05-108	Line Strainer O'ring/Seal	1	RSP
33	069-581	Diverter Valve Installation	1	RSP
34	A030784	Hydraulic Cylinder	1	RSP
35	069-581	Diverter Valve Assembly	1	RSP
36	024-048	Diverter Valve Overhaul Kit	1	RSP
37	024-047	Diverter Valve Seal Kit	1	RSP
38	078-1010	Modification to Fluid Head	1	RSP
39	TBC	Fluid Head Valve Assembly	6	RSP
40	TBC	Fluid Head Packing Seals	3	RSP
41	TBC	Plungers	3	RSP
42	051-1062	Engine Alternator	1	RSP

43	05I-1063	Engine Starter Motor	I	RSP
44	05I-1064	Fuel Stop Solenoid	I	RSP
45		5 Amp Fuse Solenoid	I	RSP
46		20 Amp Fuse Murphy	I	RSP

10.4. Parts List

Component	Description	Qty
0118131	DRIP TRAY 320 UNIT	1
012061	PLUG BRASS FLANGED 1/2" BSP	1
013014	ADAPTOR 1/4" BSP M x 1/4" BSP M 415 BAR	2
013038	ADAPTOR 3/8" BSP x 1/4" BSP M/M 415BAR	1
013039	ADAPTOR 1/2" BSP M x 1/2" BSP M 415 BAR C-TXT	6
013046	ADAPTOR 3/4" BSP M x 1/2" BSP M 345 BAR	2
013053	HOSE CLIP DIA 25-35 JCS HI-GRIP S/S	10
013064	HOSE CLIP DIA 17-25 (OX) JCS HI-GRIP S/S	6
013107	BOLT HEX HD M12-1.75 6G 120MM LG HT 8.8 ZN	4
013203	ADAPTOR BHEAD 3/8" BSPM x 3/8" BSPM 415 BAR C/W LNUT	2
013224	ADAPTOR BHEAD 1/2" BSPM x 1/2" BSPM 415BAR C/W LNUT	4
013266	SEAL DOWTY 1 1/4" BSP SELF CENTERING	13
013349	CLIP "R"	1
013813	SCREW THREAD CUTTING PAN HEAD TORX DRIVE 6.0 mm x 16 mm ZINC PLATED	5
013916	WASHER NEOPRENE RUBBER 14mm O/D 6.35mm I/D 3mm THK	2
013938	SCREW HEX HEAD M10x1.25 x 30MM LG ZN	22
013943	FEMALE BOBBIN MOUNT TYPE 2 / B AV 3015MF20-60	4
014013	HOSE CLIP DIA 20-30 JCS HI-GRIP S/S	4
014201	P CLIP 25mm ZINC PLATED	1
014277	HANDLE 8535-202	2
014284	HOOD LATCH RUBBER 339-9151	5
014288	HOSE CLIP DIA 8-10 JCS HI-TORQUE RS727-5914	4
015173	SEAL BONDED 1" BSP 400-830-4490-41 780 BAR SELF CENTRALISING	1
015315	GASKET CONTROL PANEL 315 SERIES MK3 (2018)	1
016245	KEY 1/4" X 1/4" X 60MM LONG	1
016267	AV MOUNT CAPTIVE TRANSIT CTM633512/6 REAR	2
016401	FLYWHEEL HOUSING MACHINED CENTER BORED - TO SUIT KUBOTA D1105 - 052369	1
016416	AV MOUNT CAPTIVE TRANSIT CTM633512/5 REAR (FLYWHEEL)	2
016423	AV MOUNT CAPTIVE M10 CTM833510-40	1
018005	VALVE SPOOL HYD FLOW CONTROL	1
021090	ADAPTOR 3/4" BSPM x 3/8" BSPM 415 BAR	2
023011	ANGLE SWIVEL JOINT 90 DEG 1/2" BSP M/M 415BAR	1
023016	PLUG BLANKING 1/2" BSP 415 BAR	1
023023	INSERT FOR HOSE SWAGED 3/8" BSP FEM	1
023025	INSERT FOR HOSE SWAGED 1/2" BSP FEM	3
023028	TEE 3/8" BSP M 415BAR	1
023030	INSERT FOR HOSE SWAGED 3/4" BSP FEM	1

023041	O CLIP 3/4"	10
023047	HOSE CLIP DIA 30-40 JCS HI-GRIP S/S	8
0231060	1/2"BSP X 1 1/4BSP MALE/MALE PARALLEL 215 BAR	1
0231248	INSERT HOSE STRAIGHT 1" BSPM x 25mm DIA HOSETAIL 316 STAINLESS STEEL	2
0231414	INSERT HOSE 1/8" BSP 90 DEG FEMALE	1
023147	ADAPTOR 1" BSP M x 3/4" BSP M 210 BAR	1
0231674	ADAPTOR HOSETAIL INSERT 90 DEG 3/8" BSP SWIV STAIN. S	1
0231734	ADAPTOR CROSS 1/2" BSP M/M/M/M ZN 415 BAR	1
023203	INSERT FOR HOSE 1"BSP FEM SWAGED TYPE	2
023215	ADAPTOR 3/8"BSP Mx 3/8"BSP F SWIVEL 415BAR	1
023261	ADAPTOR 1/2"BSPM x 1/2"BSPF SWIVEL 415 BAR ZINC	2
023262	ADAPTOR 1/2"BSP FEMALE FIXED TEE 415 BAR	2
023273	ADAPTOR BULKHEAD 3/4"BSP X 3/4"BSP MALE C/W LOCKNUT 210 BAR	1
023347	INSERT FOR HOSE SWAGED 3/4"BSP 90DEG FEM	2
023362	ADAPTOR 1/2"BSP M x 7/8"-14 JIC M 415BAR	2
023379	ADAPTOR BHEAD 1 1/4" BSPM x 1 1/4" BSPM 210 BAR C/W NUT	1
023391	PLUG BLANKING 1/2" BSP ST/ST 550 BAR	1
023569	PIN CANOPY RETAINER	1
023609	ADAPTOR 1-1/4"BSPM X 3/4 BSPM ZN 210 BAR	1
023653	1/4"BSPM-1/4"BSPF SWIVEL 90 COMP. ELBOW 415BAR	1
023712	ADAPTOR M16 X 1.5 - 3/8"BSP M/M MS ZN 1MB/16-6	1
023847	ADAPTOR 1.1/4" BSP M/F SWIV 2B/20 210 BAR	1
023932	ELBOW 3/8"BSPT-3/8"BSP M/M FORGED 420BAR W. P	1
023978	INSERT FOR HOSE 1 1/4"BSP FEM 90 DEG SWIV MS A50051-20-20	1
031340	TEE 3/8"BSP MALE/FEMALE RUN MALE BRANCH ZINC	1
032459	SPACER SHAFT HYDRAULIC H/REEL MINI VANPACK	1
033005	ADAPTOR 3/8" BSP M x 3/8" BSP M 415 BAR	2
033006	ADAPTOR 1/2" BSP M x 3/8" BSP M 415 BAR ZN	5
033010	SEAL BONDED 1/2" BSP 400-825-4490-41 448 BAR SELF CENTRALISING	22
033011	ADAPTOR 1/2"BSP M x 1/4"BSP M 415BAR	1
033012	SEAL BONDED 1/4" BSP 400-821-4490-41 616 BAR SELF CENTRALISING	3
033013	SEAL BONDED 3/8" BSP 400-823-4490-41 492 BAR SELF CENTRALISING	7
033013	SEAL BONDED 3/8" BSP 400-823-4490-41 492 BAR SELF CENTRALISING	2
033014	SEAL BONDED 3/4" BSP 400-827-4490-41 420 BAR SELF CENTRALISING REPLACES A041271	7
033015	SEAL BONDED 1.0" BSP 400-830-4490-41 312 BAR SELF CENTRALISING	3
033068	ADAPTOR BHEAD 1" BSPM x 1" BSPM 210 BAR C/W LOCNUT	1
033103	ADAPTOR 1"BSPM X 1"BSPM 210BAR (SAME AS N01-570)	1
035072	VALVE 1 1/4"BSP T PORT 375 PSI FIG 2000 S/R TYPE 98 ALBION	1
035185	UNLOADER VALVE UL221/200H G1/2" 50LPM 210BAR WITH HANDLE WHEEL	1
035235	VALVE BALL 3/8" BSP complete with STRAIGHT HANDLE 6000PSI min WP HANDLE PART NUMBER 035095	1
035401	VALVE SAFETY RELIEF (SRV) VS 310 HAWK 310 BAR @ 40LPM	1
037010	NIPPLE GREASE 1/8"BSP	1
038108	SPRING GUARD 24mm I/D	0.2

041034	STUDDING M10 ZINC PLATED [PER 1.5 METER]	1
0422319	SUPPORT TANK FILL POINT VANPACKS (POWDER COAT)	1
0422956	BRACKET 3 WAY VALVE ASSY 115 SERIES MK2 (POWDER COAT)	1
0423179	CONTROL PANEL BOX 315 SERIES MK3 MURPHY	1
0423181	BRACKET UNLOADER VALVE 315 SERIES MK3	1
0423183	ENGINE FOOT KUBOTA D1105	3
0423185	BRACKET THROTTLE ACTUATOR KUBOTA D1105 315 SERIES MK3	1
0423186	BATTERY CRADLE 315 SERIES MK3 (2018)	1
0423315	CONTROL PANEL 320 SERIES MURPHY (supersedes 042-3180)	1
0423316	CANOPY SUPPORT 320 SERIES (supersedes 042-2869)	1
0423329	EXHAUST MOUNTING PLATE UNIT 320	1
0423337	320 cooler plate	1
0423347	320 UNIT PERFORATED GUARD	1
0423348	SWING ARM HOSE REEL TRACE 320 UNIT	1
0423380	330 UNIT EXHAUST HOUSING	1
0423381	330 UNIT EXHAUST HOUSING COVER	1
0423410	330 SERIES EXHAUST SUPPORT ANGLE	2
0423412	ENGINE FOOT KUBOTA D1105 inc RELAY HOLE	1
0423413	320 UNIT FRAME EXHAUST STUB	1
0423457	PUMP SUPPORT 320	1
043018	CAP HYD/FUEL TANK	3
043061	HOSE CLIP DIA 9.5-12 JCS HI-GRIP S/S	10
043074	VALVE 1" BSP SHUT OFF 200PSI TYPE 750 R751T	1
043186	ADAPTOR 1" BSPT-30MM UPVC HOSETAIL	1
043196	ELBOW 90 DEG. THREADED 1 1/4" BSPF UPVC	1
043203	PLUG BLANKING 1" BSPT GALVANISED IRON (do not use - now use 044029)	1
043222	INSERT HOSE 1 1/4" BSPM X 32 MM DIA HOSETAIL UPVC	3
043235	ADAPTOR FLANGED 1 1/4" BSPM X 1 1/4" BSPM UPVC	1
044543	FRAME 320 SERIES MK1 VANPACK	1
047004	STEM OUTLET (INLET HOSE REEL)	2
048011	SPACER 10MM LG HOSE FEED GUIDE HYD REEL P TYPE	4
048016A	MOTOR HYDRAULIC DANFOSS OMR 315 (POWDER CAT)	1
048103	TUBE WATER OUTLET FOR HYDRAULIC HOSE REEL N15-142 AND 048-110	1
048106	INLET HOSEREEL PERPENDICULAR WALL MOUNT - RAPID REEL	1
050065	EXHAUST FLEXIBLE TUBING 1MTR ST.ST 40MM O/D	1
050232	CABLE ADJUSTER 6MM 9180.191 SIMILAR TO A030205 LOMBARDINI FOCS	1
050295	OUTER CASING PER METER CABLE-TEC	1.3
050296	WIRE 1.9MM PER METER CABLE-TEC	1.52
050317	HEAT EXCHANGE - ENGINE COOLING VAN PACK - HIGH FLOW, CAST ENDS	1
050324	PTO HYDRAULIC PUMP KUBOTA D1105	1
050325	THERMOSTAT OUTLET 1105D COOLER	1
0511009	CABLE END - CHOKE - HONDA GX690 CABLE HOLDER	1
0511066	KUBOTA D1105 EXHAUST GASKET	1
052369	ENGINE KUBOTA D1105-E4B-EU-X1 1J90600000	1

055024	HOSE 1/2" P.V.C. CLEAR BRAIDED [PER METER] HDPVC12	3
055029	HOSE 1" HELIFLEX [PER METER]	2.5
055063	HOSE 1 1/4" HELIFLEX [PER METER]	3.5
055070	HOSE ASSY 1/2" 01.37M STR/ELB 1/2" BSPF EN 853 2SN	1
0551068	HOSE ASSY 3/4" TRICOFLEX 25 METERS LONG	1
0551093	HOSE ASSY 1/4" BSP COMP ELB/COMP ELB DIN 20022 2SN 0.700m LG	1
0551192	3/8" FUEL HOSE (PER METER)	2
0551192	3/8" FUEL HOSE (PER METER)	1
0551257	HOSE ASSY 1/2" BSP STR/ELB 2WB MILD STEEL 0.5M LG 415 BAR WP	1
0551283	HOSE ASSY 1/4" STR/COM ELB 670 LG 415 BAR WP	2
0551592	HOSE ASSY 1/4" BSPF ELB/STR 550MM LONG 415 BAR	1
0551597	HOSE ASSY 3/8" BSPF ELB/ELB	2
0551602	HOSE ASSY 3/8" BSPF ELB/STR	1
0551604	HOSE ASSY 3/8" BSPF STR/STR	1
0551618	FUEL HOSE 1/8" – TBSE 300	1
0551621	HOSE ASSY 1/2" BSPF ELB/ELB 210 BAR WP 470mm LG 270 DEG	1
0551622	HOSE ASSY 3/8" BSPF 2WB ELB/ELB 0.86M LONG (Spool Valve to Hyd Motor)	1
0551650	HOSE ASSY 1/2" BSP ELB/ELB 1.50M LONG 90DEG 415 BAR WP (SELECTOR TO H/REEL)	1
0551801	1" RED HOSE Autosiliconehoses.com	1
0551802	1" BLUE HOSE Autosiliconehoses.com	1
0551817	1" BLUE U BEND 180DEG HOSE	1
055431	RUBBER-FUEL-LINE DIA 6MM	2.6
055985	HOSE ASSY DN10 3/8" 1.05M STR/ELB EN 853 2SN	1
058298	PIPEWORK HOSE JOINER 1" x 1" x 3/8" STEEL PLATED	1
058301	320 COOLANT RADIUS' 25MM DIA @ 100MM CLR	1
059115	FRONT PANEL GRP MOULDED 320 SERIES (supersedes 058-287)	1
061030	SPACER D.T & D.T.T. FUEL TANK	3
061434	LABEL "E-STOP" SELF ADHESIVE	1
061829	STATUTORY LABEL PLATE TRAILER	1
061851	LABEL 'BRITISH INDUSTRY'	1
061864	LABEL WARNING DO NOT RUN PUMP DRY, SEE SECTION 5 OF MANUAL	1
061871	KEY RING HARBEN	1
061880	PEEL AWAY SAFETY STICKER	1
061886	USB MANUALS	1
061951	LABEL SET 320 SERIES	1
061970	LABEL - READ MANUAL AND HEALTH AND SAFETY MANUAL	0
061970	LABEL - READ MANUAL AND HEALTH AND SAFETY MANUAL	0
067853	GEARBOX 2.176:1 SPECK NP25	1
069581	KIT HYDRAULIC DIVERT VALVE INSTALLATION - Mk2	1
0711023	4.8MM SADDLE TYPE CABLE TIE MOUNT RS PT NO. 666-717	1
0711024	8MM SADDLE TYPE CABLE TIE MOUNT RS PT NO. 666-739	22
0711040	PVC CABLE GROMMET 9MM MAX. CABLE, 15MM HOLE DIAM.	1
0711135	CABLE GLAND M16 5-10mm IP68 BLACK	1
0711158	LEAD BATTERY 940mm POSITIVE 12V	1

0711240	TELERADIO RADIO CONTROL SYSTEM CANOPEN - TRANSMITTER AND RECIEVER	1
0711242	PRESSURE TRANSMITTER 0-300 BAR 4-20mA	1
0711340	12V CIGARETTE LIGHTER OUTLET PIXNOR UNIVERSAL WATERPROOF WITH CAP PANEL MOUNT	1
0711355	BATTERY 063 V SILVER	1
0711382	CONTROL PANEL MURPHY MPC-20 CUSTOM FRONT	1
0711383	WIRING LOOM CONTROL PANEL MPC-20 SINGLE 21 PIN CONNECTOR	1
0711387	SIREN / SOUNDER 8-35V DC	1
0711390	GASKET FOR MPC-20 CONTROLLER	1
0711392	MAGNETIC PICK UP 68MP0060 M16x1.5	1
0711395	WIRING HARNESS 320 TELERADIO	1
0711408	ROCKER SWITCH ON/OFF BLACK 21A @ 14V SPST IP56 LATCHING	1
0711452	LEAD BATTERY 1050mm NEGATIVE 12V	1
071261	SHRINK SLEEVING BORE 19.0 TO 9.5 SHRINK	0.15
071261	SHRINK SLEEVING BORE 19.0 TO 9.5 SHRINK	1
071367	E STOP TWIST TO RELEASE including NC ACTUATOR 78-3724 78-3732	1
071653	BATTERY CABLE BLACK 16MM SQ TYPE BK RS 516-8016	1.3
071786	RELAY 12V 120AMP RP/120-12	1
071886	FLOAT SWITCH HORIZONTAL POLYPROPYLENE 1/2" NPT 397-0564 (HOTSHOT 200 FUEL TANK)	1
071901	ELECTRICAL PISTON TYPE PE40-35GV12	1
071902	ELECTRICAL UNIT CONTROL TYPE S.FCESY7V12	1
073069	HEAT SHRINKABLE SLEEVING 9.5MM BORE (RS398-177)	0.2
0781010	MODIFICATION TO FLUID HEAD NP25 SPECK FOR JUMP JET - 54-200	1
0781075	CABLE END - MODIFIED - TO SUIT YANMAR	1
0781130	DRIVE SHAFT 1 1/8" KEYED FOR KUBOTA 1105D 315 SERIES MK3	1
078393	CABLE GRIP HOLDER TO CLEVIS/THROTTLE	1
078417	EXTENDED HEX NUT M8	1
079260	EXHAUST OUTLET FLANGED 'U' BEND - KUBOTA D1105	1
079261	EXHAUST FLANGE STUB KUBOTA D1105	1
079274	EXHAUST CLAMP 4"	2
085344	TANK HYDRAULIC PLASTIC 315 SERIES MK2 (BEHIND H/REEL MOUNT)	1
085344	TANK HYDRAULIC PLASTIC 315 SERIES MK2 (BEHIND H/REEL MOUNT)	1
085389	TANK FUEL PLASTIC 320 SERIES MK1	1
085389	TANK FUEL PLASTIC 320 SERIES MK1	1
085396	EXPANSION TANK 320 COOLING SYSTEM	1
085397	400L WATER TANK 320	1
085406	320 SERIES ANTIFREEZE TANK	1
094103	Elbow 45 deg Male Female 1" BSPT x malleable iron galvanised	1
A0101371	FITTING ADAPTOR 1" BSP 1" BSP MPC/FPC SWIVEL	1
A010143	ADAPTOR 3/8" BSP SWIVEL TO 3/8" BSP SWIVEL 415 BAR WP	1
A0300321	FASTENER EXHAUST CLAMP 1.5/8	2
A030206	CABLE GRIP (SCREWED) AND NUT FOR LOMBARDINI FOCS	1
A140909	PLAIN DOWEL PIN M8 X 20	1
A160500	PLUG 2" BSPT GALV REF 147	2
A180430	ROD STRAP RETAINER WATER TANK	4
A190821	STRAP ASSEMBLY RATCHET TYPE. 25MM WIDE NYLON	2

N00862	SCREW GRUB M6 x 10 LG	2
N00864	M10x10 GRUB SCREW	2
N01280	ELBOW 1" BSP MXF MALLEABLE GALV	2
N01282	ELBOW 1 1/4 BSP MXF MALLEABLE GALV	2
N01456	3/8" BSPF SWIVEL X 3/8" BSPM 90DEG COMPACT ELBOW 415 BAR	2
N01472	ELBOW 90DEG COMPACT 3/8 BSPF x 3/8 BSPF ZN	1
N01492	ADAPTOR 1/2" BSPM x 1/2" BSPTM 415 BAR WP	2
N01496	ELBOW 1/2-1/2 BSP Mx F 90 COMPACT FORGED 415BAR	2
N01518	INSERT 1/2" BSP F 90 DEG COMPACT (PUSH IN) ZINC 415 BAR	7
N01794	BEARING PLUMMER BLOCK HOUSING 1" C/W GREASE NIPPLE (POWDER COAT)	1
N01799	BEARING NEEDLE BUSH	1
N01965	1/4 BSPF S/STEEL CHECK VALVE C25P/9K	1
N02230	ADAPTOR 1/2" BSPM X 1/8" BSPM ZN	1
N05085	HANDLE GRIP PLASTIC	1
N05105	LINE STRAINER 1 1/4" (HYPRO)	1
N05114	SIGHT GLASS 10"	2
N05116	SIGHT LEVEL GAUGE 5116/7	1
N05270	BATTERY CABLE RED 16MM SQ TYPE BK RS516-8038	1.9
N05798	HYDRAULIC FILTER (U.C.C. MX1518.102) RETURN FILTER	1
N10001	BATTERY RETAINING BRACKET	1
N15142	HYD HOSEREEL (POWDER COAT)	1
N15190	ADJUSTING SPACER CONVEX (POWDER COAT)	2
N20836A	BEARING HOUSING HYD HOSE REEL (POWDER COAT)	1
N20838	HOSE REEL SHAFT (FLUID END)	1
N20839	HOSE REEL SHAFT ZINC PLATED	1
N20843	TRACE ROLLER	5

10.5. Hydraulic Divertor Valve Assembly

10.5.1. Recommended Tools

054041	GREASE ESA 100
069186	LUBRICATING METAL PASTE
054003	OIL SHELL TELLUS 150
033275	DRIFT VALVE SPINDLE

10.5.2. Service Kits

024047	KIT SEAL CENTURY TRIGGER ASSY	
013345	O RING BS019/90	4
015062	GLYD RING SEAL	2
015063	STEPSEAL	2
033279	OVERHAUL KIT CENTURY TRIGGER ASSY	
013345	O RING BS019/90	4
015062	GLYD RING SEAL	2
015063	STEPSEAL	2
033293	CENTER COLLAR	1
033264	SCRAPER	1
033294	END COLLAR	2
033295	GLAND	2
033296	SPINDLE	1
033275	DRIFT VALVE SPINDLE	1

Before attempting to overhaul the diverter valve, the machine must be switched off and all hoses and adaptors to the selector disconnected.

10.6. To Dismantle

1. Unscrew the four M8 bolts (4) and remove cylinder (3) (DRG 026-111).
2. Unscrew the three M8 cap head screws (17) (DRG 035-255) and remove the adaptor (2) (DRG 026-111) from the water valve body (18) (DRG 035-255)
3. Remove the spring cap (8) from water valve body (18) (DRG 035-255)
4. TO DISMANTLE THE SPRING PACK: Using a vice fitted with soft jaws and small dia bar, approx. 5mm, compress the spring mount (6) and disc springs (1) into the cap (8) and remove circlip (2) (DRG 035-255)
5. Place drift 033275 over spindle (12), tap end of drift gently and remove internal water valve parts. Keeping all parts in order, separate out the spindle stack and remove seals (4), (3) & (15) and scraper (7) (DRG 035-255).

10.7. To Assemble

1. Check all parts for burrs, swarf, and damage, then clean thoroughly and lay components out on a clean area.
2. Gently ease both step seals (4) into glands (11) making sure step of inner seal faces pressure (DRG 035-255)
3. Gently ease both Glyd rings (3) into end collars (10) making sure stepped side of inner seal is visible when fitted (DRG 035-255)
4. Fit center collar (9) between the two end collars (10). This may be a slide, or a light press fit into the collars (DRG 035-255)
5. Holding glands (11) against end collars (10) with step seals facing end collar, gently push lightly oil spindle (12) right the way through internal bore of stack until spindle (12) stops up against face of gland (11) (DRG 035-255)
6. Fit four O-rings (15) to items (10) and (11) (DRG 035-255)
7. Slide scraper (7) over end of spindle (12) (DRG 035-255)
8. Lightly grease O-rings (15), and gently push the complete spindle stack into the water valve body (18). It may be necessary using a Delrin rod to gently tap, evenly and squarely, the spindle stack into the body (18) (DRG 035-255)
9. Stack disc springs (1) onto the spring mount (6) as shown on the (DRG 035-255) and grease the complete stack.
10. Fit the greased spring stack into cap (8) and using a vice fitted with soft jaws and a small diameter bar, approx. 5mm, compress the spring mount (6) and disc springs (1) into the cap (8) bore enough to enable the circlip (2) to be fitted in groove on the wall of cap (8). Then pressure can be gently released and spring mount (6) will stop against circlip (2) (DRG 035-255)

11. Apply metal paste to threads of cap (8) and screw into body (18) and torque to 41Nm (DRG 035-255)
12. Locate the adaptor cylinder (2) (DRG 026-111) onto the water valve body (18) DRG 035-255/3 and secure with the three M8 socket button headset screws (17) (DRG 035-255)
13. Replace screw set & washer (5&6) (DRG 026-111)
14. Replace cylinder (3) and the four M8 cap screws (4) (DRG 026-111)

Diverter Valve Hydraulic Actuation – 035255

Component	Description	Qty
014076	DISC SPRING S168206 Stainless Steel	45
014106	CIRCLIP 1700 METRIC X 18 ANDERTON	1
015062	GLYD RING SEAL SHAMBAN S-50992-5907-010	2
015063	STEPSEAL (SHAMBAN) (S-55015-0100-80)	2
032472	CHOKE MKII SOLINOID VALVE	1
033263	SPRING MOUNT BODY ASSY CENTURY GUN	1
033264	SCRAPER BODY ASSY CENTURY GUN	1
033268	CAP BODY CENTURY GUN	1
033293	CENTER COLLAR BODY ASSY CENTURY GUN MODIFIED	1
033294	END COLLAR BODY ASSY CENTURY GUN MODIFIED	2
033295	GLAND BODY ASSY CENTURY GUN MODIFIED	2
033296	SPINDLE CENTURY GUN MODIFIED	1
033306	HOLDER FOR CHOKE	1
013039	ADAPTOR 1/2" BSP M x 1/2" BSP M 415 BAR	2
013345	O RING BS019/90	4
033010	SEAL BONDED 1/2" BSP 400-825-4490-41 448 BAR	3
A040814	SCREW CAPSCREW M8 X 20MM LONG SOCKET HD	3
078200	BODY WATER DIVERTER VALVE AIR OPERATED	1

Kit Hydraulic Divert Valve Installation - 026111

Component	Description	Qty
035255	DIVERTER VALVE HYDRAULIC ACTUATION 6000PSI	1
078718	ADAPTOR CYLINDER TO BODY UNLOADER VALVE	1
A030784	CYLINDER/COMPACT/63 DIA/10 STROKE/SINGLE ROD/PNEU	1
013500	BOLT SOCKET CAP HD M8-1.25 6G 60mm LG 8.8 Zn	4
013246	SCREW SET HEX HD M10-1.5 6G 20 LG HT 8.8 ZN	1
013094	WASHER S/COIL SQR.SECTION M10 SPRING STEEL ZN	1
069400	SOLENOID VALVE 4/2 HYD 12VDC CETOP 3 C/W PLUG	1
069458	SUB PLATE SIDE PORTED ISO 03 3/8" BSP ESU	1
069459	VALVE HYDRAULIC PRESSURE REDUCING/RELIEVING	1
033013	SEAL BONDED 3/8" BSP 400-823-4490-41 492 BAR	4
033005	ADAPTOR 3/8" BSP M x 3/8" BSP M 415 BAR	2
013014	ADAPTOR 1/4" BSP M x 1/4" BSP M 415 BAR	1
013038	ADAPTOR 3/8"BSP x 1/4"BSP M/M 415BAR	2
013211	ADAPTOR BHEAD 1/4" BSPM x 1/4" BSPM 415 BAR C/W LNUT	1
033012	SEAL BONDED 1/4" BSP 400-821-4490-41 616 BAR	3
013140	PLUG BLANKING 1/4"BSP	1
0231069	SPECIAL ADAPTOR ASSY 3/8" BSP M/M 3.5 DIA HOLE	1

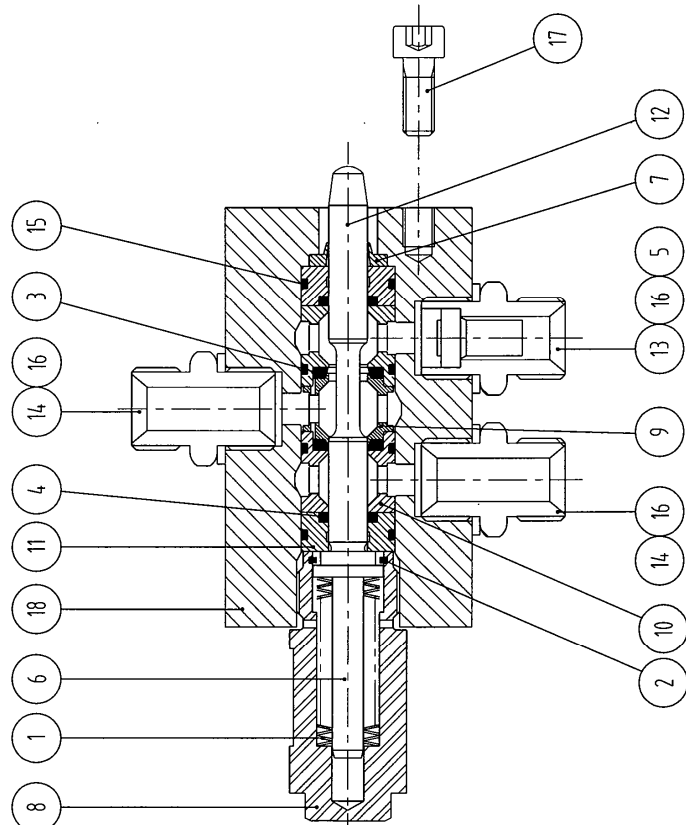
<p>DO NOT SCALE, IF IN DOUBT ASK © COPYRIGHT 2008 FLOWPLANT GROUP LTD</p>	<p>THIS DRAWING IS CONFIDENTIAL AND IS SUPPLIED ON THE EXPRESS CONDITION THAT IT IS NOT COPIED OR COMMUNICATED TO OTHER PERSONS OR COMPANIES WITHOUT WRITTEN PERMISSION FROM FLOWPLANT GROUP LTD</p>	<p>MANUFACTURERS UNABLE TO COMPLY MAY SUBMIT ALTERNATIVES WHEN QUOTING. LATEST ISSUES ARE TO BE REQUESTED.</p>	<p>THIRD ANGLE PROJECTION!</p>	<table border="1" style="width:100%; border-collapse: collapse;"> <tr> <th>ITEM</th> <th>PART NO.</th> <th>DRG. NO.</th> <th>QTY.</th> <th>DESCRIPTION</th> <th>REMARKS</th> </tr> <tr> <td colspan="6" style="text-align: center;">PARTS LIST</td> </tr> </table>	ITEM	PART NO.	DRG. NO.	QTY.	DESCRIPTION	REMARKS	PARTS LIST																																				
ITEM	PART NO.	DRG. NO.	QTY.	DESCRIPTION	REMARKS																																										
PARTS LIST																																															
																																															
<table border="1" style="width:100%; border-collapse: collapse;"> <tr> <th>OVER</th> <th>0</th> <th>30</th> <th>100</th> <th>300</th> <th>1000</th> <th>2000</th> <th>MATL.</th> </tr> <tr> <td>UP TO AND INCLUDING</td> <td>30</td> <td>100</td> <td>300</td> <td>1000</td> <td>2000</td> <td></td> <td></td> </tr> <tr> <td>* DATE</td> <td></td> <td></td> <td></td> <td></td> <td></td> <td></td> <td>SPEC/PT NO.</td> </tr> <tr> <td>RANGE</td> <td>± 0.1 ± 0.5 ± 0.2</td> <td>± 0.3 ± 0.5 ± 0.8</td> <td>± 0.3 ± 0.5 ± 0.8</td> <td>± 0.3 ± 0.5 ± 0.8</td> <td>± 0.3 ± 0.5 ± 0.8</td> <td>± 0.3 ± 0.5 ± 0.8</td> <td>SIZE</td> </tr> <tr> <td>FABRICATED/ASSEMBLED</td> <td>± 0.3 ± 0.5 ± 0.7</td> <td>± 1.0 ± 1.0 ± 1.5 ± 2.0</td> <td>± 0.5 ± 1.0 ± 1.5 ± 2.0 ± 3.0</td> <td>± 0.5 ± 1.0 ± 1.5 ± 2.0 ± 3.0</td> <td>± 0.5 ± 1.0 ± 1.5 ± 2.0 ± 3.0</td> <td>± 0.5 ± 1.0 ± 1.5 ± 2.0 ± 3.0</td> <td>FINISH.</td> </tr> </table>						OVER	0	30	100	300	1000	2000	MATL.	UP TO AND INCLUDING	30	100	300	1000	2000			* DATE							SPEC/PT NO.	RANGE	± 0.1 ± 0.5 ± 0.2	± 0.3 ± 0.5 ± 0.8	± 0.3 ± 0.5 ± 0.8	± 0.3 ± 0.5 ± 0.8	± 0.3 ± 0.5 ± 0.8	± 0.3 ± 0.5 ± 0.8	SIZE	FABRICATED/ASSEMBLED	± 0.3 ± 0.5 ± 0.7	± 1.0 ± 1.0 ± 1.5 ± 2.0	± 0.5 ± 1.0 ± 1.5 ± 2.0 ± 3.0	± 0.5 ± 1.0 ± 1.5 ± 2.0 ± 3.0	± 0.5 ± 1.0 ± 1.5 ± 2.0 ± 3.0	± 0.5 ± 1.0 ± 1.5 ± 2.0 ± 3.0	FINISH.		
OVER	0	30	100	300	1000	2000	MATL.																																								
UP TO AND INCLUDING	30	100	300	1000	2000																																										
* DATE							SPEC/PT NO.																																								
RANGE	± 0.1 ± 0.5 ± 0.2	± 0.3 ± 0.5 ± 0.8	± 0.3 ± 0.5 ± 0.8	± 0.3 ± 0.5 ± 0.8	± 0.3 ± 0.5 ± 0.8	± 0.3 ± 0.5 ± 0.8	SIZE																																								
FABRICATED/ASSEMBLED	± 0.3 ± 0.5 ± 0.7	± 1.0 ± 1.0 ± 1.5 ± 2.0	± 0.5 ± 1.0 ± 1.5 ± 2.0 ± 3.0	± 0.5 ± 1.0 ± 1.5 ± 2.0 ± 3.0	± 0.5 ± 1.0 ± 1.5 ± 2.0 ± 3.0	± 0.5 ± 1.0 ± 1.5 ± 2.0 ± 3.0	FINISH.																																								
<p>FLOWPLANT GROUP LTD LEADERS IN CLEANING TECHNOLOGY</p> <p>Flowplant Group Ltd. Gemini House, Brunel Road, Churchfields, Salisbury, Wilts. SP2 7PU England. Tel: +44 (0) 1722 325424 F: 411329</p>																																															
<table border="1" style="width:100%; border-collapse: collapse;"> <tr> <th>DATE</th> <th>ISSUE</th> <th>DATE</th> <th>DATE</th> <th>DATE</th> <th>DATE</th> <th>TITLE</th> </tr> <tr> <td>04/06/07</td> <td>1</td> <td></td> <td></td> <td></td> <td></td> <td>DIVERTER VALVE</td> </tr> <tr> <td>DWG</td> <td>CHK</td> <td>DRN</td> <td>APP</td> <td>CHK</td> <td>TEST</td> <td>HYDRAULIC ACTUATION</td> </tr> <tr> <td></td> <td></td> <td></td> <td></td> <td></td> <td></td> <td>6000 PSI</td> </tr> <tr> <td></td> <td></td> <td></td> <td></td> <td></td> <td></td> <td>DRG NO. 035-255/3.1</td> </tr> <tr> <td></td> <td></td> <td></td> <td></td> <td></td> <td></td> <td>PART NO. 035255</td> </tr> </table>						DATE	ISSUE	DATE	DATE	DATE	DATE	TITLE	04/06/07	1					DIVERTER VALVE	DWG	CHK	DRN	APP	CHK	TEST	HYDRAULIC ACTUATION							6000 PSI							DRG NO. 035-255/3.1							PART NO. 035255
DATE	ISSUE	DATE	DATE	DATE	DATE	TITLE																																									
04/06/07	1					DIVERTER VALVE																																									
DWG	CHK	DRN	APP	CHK	TEST	HYDRAULIC ACTUATION																																									
						6000 PSI																																									
						DRG NO. 035-255/3.1																																									
						PART NO. 035255																																									
<p>TOLERANCES TO BE AS SPECIFIED ABOVE UNLESS OTHERWISE STATED. SUPERSEDES/ SUPERSEDED BY HEAT TREATMENT.</p>																																															

<p>DO NOT SCALE, IF IN DOUBT ASK!</p> <p>THIS DRAWING IS CONFIDENTIAL AND IS SUPPLIED ON THE EXPRESS CONDITION THAT IT IS NOT COPIED OR COMMUNICATED TO OTHER PERSONS WITHOUT WRITTEN PERMISSION FROM FLOWPLANT GROUP LTD.</p> <p>© COPYRIGHT 2007 FLOWPLANT GROUP LTD.</p>	<p>MANUFACTURERS UNABLE TO COMPLY MAY SUBMIT ALTERNATIVES WHICH COULD BE TESTED. THESE ARE TO BE DESTROYED.</p>	<p>THIRD ANGLE PROJECTION</p>	<p style="text-align: center;">PARTS LIST</p> <table border="1" style="width: 100%; border-collapse: collapse;"> <thead> <tr> <th>ITEM</th> <th>PART NO.</th> <th>DRG. NO.</th> <th>QTY</th> <th>DESCRIPTION</th> <th>REMARKS</th> </tr> </thead> <tbody> <tr> <td> </td> <td> </td> <td> </td> <td> </td> <td> </td> <td> </td> </tr> </tbody> </table>	ITEM	PART NO.	DRG. NO.	QTY	DESCRIPTION	REMARKS								<table border="1" style="width: 100%; border-collapse: collapse;"> <thead> <tr> <th>ISSUE</th> <th>DATE</th> <th>BY</th> <th>CHKD</th> <th>APPROVED</th> <th>DATE</th> <th>CHKD</th> <th>APPROVED</th> <th>DATE</th> <th>CHKD</th> <th>APPROVED</th> <th>DATE</th> </tr> </thead> <tbody> <tr> <td>1</td> <td>08/17/08</td> <td>RG</td> <td>DG-W</td> <td> </td> <td> </td> <td> </td> <td> </td> <td> </td> <td> </td> <td> </td> <td> </td> </tr> <tr> <td>2</td> <td>08/17/08</td> <td>RG</td> <td>DG-W</td> <td> </td> <td> </td> <td> </td> <td> </td> <td> </td> <td> </td> <td> </td> <td> </td> </tr> </tbody> </table> <table border="1" style="width: 100%; border-collapse: collapse;"> <tr> <td>ISSUE</td> <td>DATE</td> <td>BY</td> <td>CHKD</td> <td>APPROVED</td> <td>DATE</td> <td>CHKD</td> <td>APPROVED</td> <td>DATE</td> <td>CHKD</td> <td>APPROVED</td> <td>DATE</td> </tr> <tr> <td> </td> <td> </td> <td> </td> <td> </td> <td> </td> <td> </td> <td> </td> <td> </td> <td> </td> <td> </td> <td> </td> <td> </td> </tr> </table> <table border="1" style="width: 100%; border-collapse: collapse;"> <tr> <td>TITLE</td> <td>KIT HYDRAULIC DIVERT VALVE</td> </tr> <tr> <td>DRG NO.</td> <td>026-111/3 2</td> </tr> <tr> <td>PART NO.</td> <td>026111</td> </tr> </table>	ISSUE	DATE	BY	CHKD	APPROVED	DATE	CHKD	APPROVED	DATE	CHKD	APPROVED	DATE	1	08/17/08	RG	DG-W									2	08/17/08	RG	DG-W									ISSUE	DATE	BY	CHKD	APPROVED	DATE	CHKD	APPROVED	DATE	CHKD	APPROVED	DATE													TITLE	KIT HYDRAULIC DIVERT VALVE	DRG NO.	026-111/3 2	PART NO.	026111																		
ITEM	PART NO.	DRG. NO.	QTY	DESCRIPTION	REMARKS																																																																																																
ISSUE	DATE	BY	CHKD	APPROVED	DATE	CHKD	APPROVED	DATE	CHKD	APPROVED	DATE																																																																																										
1	08/17/08	RG	DG-W																																																																																																		
2	08/17/08	RG	DG-W																																																																																																		
ISSUE	DATE	BY	CHKD	APPROVED	DATE	CHKD	APPROVED	DATE	CHKD	APPROVED	DATE																																																																																										
TITLE	KIT HYDRAULIC DIVERT VALVE																																																																																																				
DRG NO.	026-111/3 2																																																																																																				
PART NO.	026111																																																																																																				
<p>THIS DRAWING IS CONFIDENTIAL AND IS SUPPLIED ON THE EXPRESS CONDITION THAT IT IS NOT COPIED OR COMMUNICATED TO OTHER PERSONS WITHOUT WRITTEN PERMISSION FROM FLOWPLANT GROUP LTD.</p> <p>© COPYRIGHT 2007 FLOWPLANT GROUP LTD.</p>			<p>MANUFACTURERS UNABLE TO COMPLY MAY SUBMIT ALTERNATIVES WHICH COULD BE TESTED. THESE ARE TO BE DESTROYED.</p>			<p>THIRD ANGLE PROJECTION</p>			<p style="text-align: center;">PARTS LIST</p> <table border="1" style="width: 100%; border-collapse: collapse;"> <thead> <tr> <th>ITEM</th> <th>PART NO.</th> <th>DRG. NO.</th> <th>QTY</th> <th>DESCRIPTION</th> <th>REMARKS</th> </tr> </thead> <tbody> <tr> <td> </td> <td> </td> <td> </td> <td> </td> <td> </td> <td> </td> </tr> </tbody> </table>			ITEM	PART NO.	DRG. NO.	QTY	DESCRIPTION	REMARKS													<table border="1" style="width: 100%; border-collapse: collapse;"> <thead> <tr> <th>ISSUE</th> <th>DATE</th> <th>BY</th> <th>CHKD</th> <th>APPROVED</th> <th>DATE</th> <th>CHKD</th> <th>APPROVED</th> <th>DATE</th> <th>CHKD</th> <th>APPROVED</th> <th>DATE</th> </tr> </thead> <tbody> <tr> <td>1</td> <td>08/17/08</td> <td>RG</td> <td>DG-W</td> <td> </td> <td> </td> <td> </td> <td> </td> <td> </td> <td> </td> <td> </td> <td> </td> </tr> <tr> <td>2</td> <td>08/17/08</td> <td>RG</td> <td>DG-W</td> <td> </td> <td> </td> <td> </td> <td> </td> <td> </td> <td> </td> <td> </td> <td> </td> </tr> </tbody> </table> <table border="1" style="width: 100%; border-collapse: collapse;"> <tr> <td>ISSUE</td> <td>DATE</td> <td>BY</td> <td>CHKD</td> <td>APPROVED</td> <td>DATE</td> <td>CHKD</td> <td>APPROVED</td> <td>DATE</td> <td>CHKD</td> <td>APPROVED</td> <td>DATE</td> </tr> <tr> <td> </td> <td> </td> <td> </td> <td> </td> <td> </td> <td> </td> <td> </td> <td> </td> <td> </td> <td> </td> <td> </td> <td> </td> </tr> </table> <table border="1" style="width: 100%; border-collapse: collapse;"> <tr> <td>TITLE</td> <td>KIT HYDRAULIC DIVERT VALVE</td> </tr> <tr> <td>DRG NO.</td> <td>026-111/3 2</td> </tr> <tr> <td>PART NO.</td> <td>026111</td> </tr> </table>						ISSUE	DATE	BY	CHKD	APPROVED	DATE	CHKD	APPROVED	DATE	CHKD	APPROVED	DATE	1	08/17/08	RG	DG-W									2	08/17/08	RG	DG-W									ISSUE	DATE	BY	CHKD	APPROVED	DATE	CHKD	APPROVED	DATE	CHKD	APPROVED	DATE													TITLE	KIT HYDRAULIC DIVERT VALVE	DRG NO.	026-111/3 2	PART NO.	026111
ITEM	PART NO.	DRG. NO.	QTY	DESCRIPTION	REMARKS																																																																																																
ISSUE	DATE	BY	CHKD	APPROVED	DATE	CHKD	APPROVED	DATE	CHKD	APPROVED	DATE																																																																																										
1	08/17/08	RG	DG-W																																																																																																		
2	08/17/08	RG	DG-W																																																																																																		
ISSUE	DATE	BY	CHKD	APPROVED	DATE	CHKD	APPROVED	DATE	CHKD	APPROVED	DATE																																																																																										
TITLE	KIT HYDRAULIC DIVERT VALVE																																																																																																				
DRG NO.	026-111/3 2																																																																																																				
PART NO.	026111																																																																																																				
<p>DO NOT SCALE, IF IN DOUBT ASK!</p> <p>THIS DRAWING IS CONFIDENTIAL AND IS SUPPLIED ON THE EXPRESS CONDITION THAT IT IS NOT COPIED OR COMMUNICATED TO OTHER PERSONS WITHOUT WRITTEN PERMISSION FROM FLOWPLANT GROUP LTD.</p> <p>© COPYRIGHT 2007 FLOWPLANT GROUP LTD.</p>			<p>MANUFACTURERS UNABLE TO COMPLY MAY SUBMIT ALTERNATIVES WHICH COULD BE TESTED. THESE ARE TO BE DESTROYED.</p>			<p>THIRD ANGLE PROJECTION</p>			<p style="text-align: center;">PARTS LIST</p> <table border="1" style="width: 100%; border-collapse: collapse;"> <thead> <tr> <th>ITEM</th> <th>PART NO.</th> <th>DRG. NO.</th> <th>QTY</th> <th>DESCRIPTION</th> <th>REMARKS</th> </tr> </thead> <tbody> <tr> <td> </td> <td> </td> <td> </td> <td> </td> <td> </td> <td> </td> </tr> </tbody> </table>			ITEM	PART NO.	DRG. NO.	QTY	DESCRIPTION	REMARKS													<table border="1" style="width: 100%; border-collapse: collapse;"> <thead> <tr> <th>ISSUE</th> <th>DATE</th> <th>BY</th> <th>CHKD</th> <th>APPROVED</th> <th>DATE</th> <th>CHKD</th> <th>APPROVED</th> <th>DATE</th> <th>CHKD</th> <th>APPROVED</th> <th>DATE</th> </tr> </thead> <tbody> <tr> <td>1</td> <td>08/17/08</td> <td>RG</td> <td>DG-W</td> <td> </td> <td> </td> <td> </td> <td> </td> <td> </td> <td> </td> <td> </td> <td> </td> </tr> <tr> <td>2</td> <td>08/17/08</td> <td>RG</td> <td>DG-W</td> <td> </td> <td> </td> <td> </td> <td> </td> <td> </td> <td> </td> <td> </td> <td> </td> </tr> </tbody> </table> <table border="1" style="width: 100%; border-collapse: collapse;"> <tr> <td>ISSUE</td> <td>DATE</td> <td>BY</td> <td>CHKD</td> <td>APPROVED</td> <td>DATE</td> <td>CHKD</td> <td>APPROVED</td> <td>DATE</td> <td>CHKD</td> <td>APPROVED</td> <td>DATE</td> </tr> <tr> <td> </td> <td> </td> <td> </td> <td> </td> <td> </td> <td> </td> <td> </td> <td> </td> <td> </td> <td> </td> <td> </td> <td> </td> </tr> </table> <table border="1" style="width: 100%; border-collapse: collapse;"> <tr> <td>TITLE</td> <td>KIT HYDRAULIC DIVERT VALVE</td> </tr> <tr> <td>DRG NO.</td> <td>026-111/3 2</td> </tr> <tr> <td>PART NO.</td> <td>026111</td> </tr> </table>						ISSUE	DATE	BY	CHKD	APPROVED	DATE	CHKD	APPROVED	DATE	CHKD	APPROVED	DATE	1	08/17/08	RG	DG-W									2	08/17/08	RG	DG-W									ISSUE	DATE	BY	CHKD	APPROVED	DATE	CHKD	APPROVED	DATE	CHKD	APPROVED	DATE													TITLE	KIT HYDRAULIC DIVERT VALVE	DRG NO.	026-111/3 2	PART NO.	026111
ITEM	PART NO.	DRG. NO.	QTY	DESCRIPTION	REMARKS																																																																																																
ISSUE	DATE	BY	CHKD	APPROVED	DATE	CHKD	APPROVED	DATE	CHKD	APPROVED	DATE																																																																																										
1	08/17/08	RG	DG-W																																																																																																		
2	08/17/08	RG	DG-W																																																																																																		
ISSUE	DATE	BY	CHKD	APPROVED	DATE	CHKD	APPROVED	DATE	CHKD	APPROVED	DATE																																																																																										
TITLE	KIT HYDRAULIC DIVERT VALVE																																																																																																				
DRG NO.	026-111/3 2																																																																																																				
PART NO.	026111																																																																																																				

11. Service Documents

11.1. Service Checklist

SERVICE CHECK LIST											
Serial Number -					Sht 1 of 2						
Unit Number -											
Date -											
Hours Run -											
					Engineer -						
					ESR -						
I - Intermediate service				Y - Yearly service				R - Customer request			
Engine				Hydraulics				Water tank			
	I	Y	R		I	Y	R		I	Y	R
1				34				63			
2				35				64			
3				36				65			
4				37				66			
5				38				67			
6				39				68			
7				40				69			
8				41				OMO Foot pedal			
9				42							
10				Electrics/Controls				70			
11								71			
12				43				72			
13				44				Pressure Hose			
14				45							
15				46				73			
Gearbox				47				74			
				48				75			
16				Vanpack frame				76			
17								77			
18				49				78			
				50				Hot Wash			
Pump				51							
				Trailer				79			
20								80			
21				52				81			
22				53				82			
23				54				83			
24				55				84			
25				56				85			
26				57				86			
27				58				87			
28				Gun & Lance				Remote Control			
29											
30				59				88			
30				60				89			
31				61				Other			
32				62							
33								90			
I Intermediate Service								91			
Y Yearly Service								92			
R At Request of Customer								93			

NA - Not applicable, A - Adjusted, √ - Satisfactory, R - Repair required, O - Observation
 Note - If 'Adjusted' or 'Repair required' please describe issue on sht 2

11.2. Service Logbook

Unit Log Book		
Serial Number -		<i>Sht 2 of 2</i>
Unit Number -		
Date of Manufacture -		
Date	Service Stamp	<div style="border: 2px solid red; width: 100px; height: 50px;"></div>
Engineer		
Type of Service	Service carried out by:	
Date	Service Stamp	<div style="border: 2px solid red; width: 100px; height: 50px;"></div>
Engineer		
Type of Service	Service carried out by:	
Date	Service Stamp	<div style="border: 2px solid red; width: 100px; height: 50px;"></div>
Engineer		
Type of Service	Service carried out by:	
Date	Service Stamp	<div style="border: 2px solid red; width: 100px; height: 50px;"></div>
Engineer		
Type of Service	Service carried out by:	
Date	Service Stamp	<div style="border: 2px solid red; width: 100px; height: 50px;"></div>
Engineer		
Type of Service	Service carried out by:	
Date	Service Stamp	<div style="border: 2px solid red; width: 100px; height: 50px;"></div>
Engineer		
Type of Service	Service carried out by:	
Type of service - Intermediate, Yearly		

12. Warranty

12.1. Warranty of New Products:

Equipment manufactured and supplied by Harben is warranted to be free from defects in materials and workmanship for a period one year or 2000 operating hours, whichever occurs soonest, from the date of shipping from our factory.

Our standard warranty covers both the parts and labor necessary to correct any such defects when repairs are carried out by us or by one of our authorized service centers.

To obtain warranty service, you should notify the Harben service department in writing within the warranty period, and they will direct you to your nearest service center. If the defect is covered by the warranty, we will repair or replace, at our option, the defective equipment, without charge for labor or materials.

Our warranty is limited to the original retail purchaser and is not transferable. We assume no responsibility for damage due to accident, neglect, abuse, tampering or misuse, or damage from repairs or alterations by others. This warranty does not cover damage to the equipment resulting from the use of non-genuine spare parts.

Warranty of Speck Pump

The warranty for the Speck pump when fitted to a trailer, truck or van pack unit manufactured by us and when used only in the sewer and drain cleaning industry is five years or 2000 hours, whichever occurs soonest, from the date of shipping from our factory.

For use in all other industries the warranty is two years or 2000 hours, whichever occurs soonest, from the date of shipping from our factory.

Parts considered as wearing parts within the Speck pump are warranted for 90 days. These parts are:

- Inlet and Delivery valves
- Diaphragms

12.2. Warranty of Major Components

Engines – Please see the engine manual that came with your machine.

Poly Tanks – All poly tanks are warranted for three years for material and workmanship.

In Order to Make A Claim:

1. You must be the original purchaser of the machine in which the part(s) were originally installed.
2. You must notify us or our authorized service agent that you wish to make a warranty claim. When requested you must return the faulty part(s) clearly labelled and carriage paid along with the unit/pump serial number and any other information that we may reasonable request.
3. All components must have been installed and maintained in accordance with good industry practice and any specific recommendations we made, including those in our maintenance schedule that is supplied with your machine.
4. We will replace, at the customers cost, any part(s) returned for warranty inspection. When our inspection has been completed, we will advise if the parts(s) are covered by our warranty policy and if they are we will credit your account for the cost of the new part(s), minus taxes and shipping charges.
5. Our warranty does not cover travel charges, down time, or consequential losses.
6. No part(s) will be considered for replacement under warranty if it is subject to any of the following reasons for exclusion.
 - Used for a purpose for which it is not designed
 - Applied to a use which has not been approved by Harben
 - Subject to misuse, negligence, lack of maintenance or accident
 - Repaired or altered in any way which, in our judgement, may adversely affect its performance and reliability
 - Considered as fair wear and tear

12.3. Limitations of Warranty:

The new product and spare parts warranty is limited to defects in material or workmanship of the product. It does not cover loss of time, inconvenience, property damage or any consequential damages. Repair or replacement of the product is your exclusive remedy.

Our liability under this clause shall be in lieu and to this exclusion of any warranty or conditions implied or expressed by law as to the quality or fitness for purpose of any goods supplied hereunder PROVIDED THAT nothing in this clause shall operate so as to exclude liability for death or personal injury arising from the negligence of the company or its employees.

Our obligations as aforesaid shall constitute the full extent of our liability in respect of any loss or damage sustained by the purchaser whether caused by any breach of this contract or by our negligence or otherwise and we shall not be liable to make good or pay for loss of use of the goods, loss of revenue, loss of profit or goodwill or any direct or consequential losses howsoever caused and the purchaser undertakes to indemnify us against any such claims against us by third parties.

All products manufactured, supplied, or installed for use at work are tested before they leave our factory and are supplied with adequate instructions for their proper use. Further copies of these instructions are available from us upon request.