

**Processes**



Stick (SMAW) Welding

**Description**



Engine Driven Welder/Generator

# Champion<sup>®</sup> 145

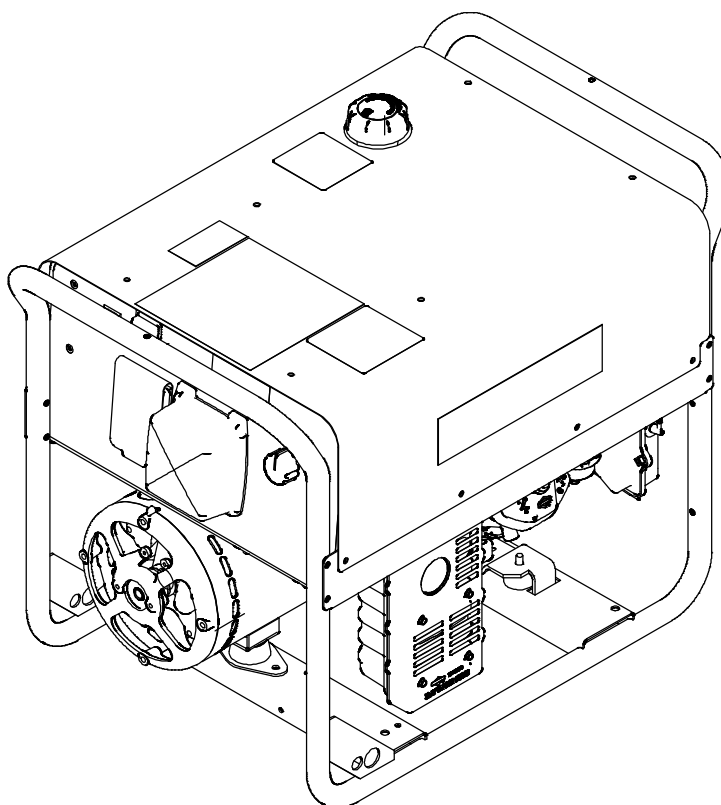

## OWNER'S MANUAL



# TABLE OF CONTENTS

<b>SECTION 1 – SAFETY PRECAUTIONS – READ BEFORE USING</b> .....	<b>1</b>
1-1. Symbol Usage .....	1
1-2. Arc Welding Hazards .....	1
1-3. Engine Hazards .....	3
1-4. Compressed Air Hazards .....	3
1-5. Additional Symbols For Installation, Operation, And Maintenance .....	4
1-6. California Proposition 65 Warnings .....	6
1-7. Principal Safety Standards .....	6
1-8. EMF Information .....	6
<b>SECTION 2 – CONSIGNES DE SÉCURITÉ – LIRE AVANT UTILISATION</b> .....	<b>7</b>
2-1. Signification des symboles .....	7
2-2. Dangers relatifs au soudage à l'arc .....	7
2-3. Dangers existant en relation avec le moteur .....	9
2-4. Dangers liés à l'air comprimé .....	10
2-5. Dangers supplémentaires en relation avec l'installation, le fonctionnement et la maintenance .....	11
2-6. Proposition californienne 65 Avertissements .....	13
2-7. Principales normes de sécurité .....	13
2-8. Informations relatives aux CEM .....	13
<b>SECTION 3 – DEFINITIONS</b> .....	<b>14</b>
<b>SECTION 4 – SPECIFICATIONS</b> .....	<b>15</b>
4-1. Serial Number And Rating Label Location .....	15
4-2. Weld, Power, And Engine Specifications .....	15
4-3. Dimensions, Weights, And Operating Angles .....	15
4-4. Duty Cycle .....	15
4-5. Environmental Specifications .....	16
4-6. Fuel Consumption .....	16
4-7. Generator Power Curve .....	16
4-8. Volt-Ampere Curves .....	16
<b>SECTION 5 – INSTALLATION</b> .....	<b>17</b>
5-1. Installing Welder/Generator .....	17
5-3. Engine Prestart Checks .....	18
5-4. Weld Output Terminals .....	18
5-5. Connecting Weld Output Cables .....	19
5-6. Selecting Cable Sizes* .....	19
<b>SECTION 6 – OPERATING THE WELDING GENERATOR</b> .....	<b>20</b>
6-1. Controls .....	20
6-2. Amperage Selection Table For Stick (SMAW) Electrodes .....	21
6-3. Cold Weather Operation .....	21
<b>SECTION 7 – OPERATING AUXILIARY EQUIPMENT</b> .....	<b>21</b>
7-1. Generator Power Panel Receptacles .....	21
7-2. GFCI Receptacle Information, Resetting, And Testing .....	22
<b>SECTION 8 – MAINTENANCE</b> .....	<b>23</b>
8-1. Routine Maintenance .....	23
8-2. Maintenance Label .....	23
8-3. Servicing Air Filter .....	24
<b>SECTION 9 – TROUBLESHOOTING</b> .....	<b>24</b>
<b>SECTION 10 – PARTS LIST</b> .....	<b>25</b>
10-1. Recommended Spare Parts .....	25
<b>SECTION 11 – ELECTRICAL DIAGRAMS</b> .....	<b>26</b>
<b>SECTION 12 – GENERATOR POWER GUIDELINES</b> .....	<b>27</b>
<b>SECTION 13 – STICK WELDING (SMAW) GUIDELINES</b> .....	<b>34</b>
<b>WARRANTY</b>	



ISO 9001  
Quality

Hobart is registered to  
the ISO 9001 Quality  
System Standard.



# SECTION 1 – SAFETY PRECAUTIONS – READ BEFORE USING

rom\_2018-06

**⚠** Protect yourself and others from injury — read, follow, and save these important safety precautions and operating instructions.

## 1-1. Symbol Usage



**DANGER!** – Indicates a hazardous situation which, if not avoided, will result in death or serious injury. The possible hazards are shown in the adjoining symbols or explained in the text.



Indicates a hazardous situation which, if not avoided, could result in death or serious injury. The possible hazards are shown in the adjoining symbols or explained in the text.

**NOTICE** – Indicates statements not related to personal injury.

## 1-2. Arc Welding Hazards



The symbols shown below are used throughout this manual to call attention to and identify possible hazards. When you see the symbol, watch out, and follow the related instructions to avoid the hazard. The safety information given below is only a summary of the more complete safety information found in the Safety Standards listed in Section 1-7. Read and follow all Safety Standards.



Only qualified persons should install, operate, maintain, and repair this equipment. A qualified person is defined as one who, by possession of a recognized degree, certificate, or professional standing, or who by extensive knowledge, training and experience, has successfully demonstrated ability to solve or resolve problems relating to the subject matter, the work, or the project and has received safety training to recognize and avoid the hazards involved.



During operation, keep everybody, especially children, away.



### ELECTRIC SHOCK can kill.

Touching live electrical parts can cause fatal shocks or severe burns. The electrode and work circuit is electrically live whenever the output is on. The input power circuit and machine internal circuits are also live when power is on. In semiautomatic or automatic wire welding, the wire, wire reel, drive roll housing, and all metal parts touching the welding wire are electrically live. Incorrectly installed or improperly grounded equipment is a hazard.

- Do not touch live electrical parts.
- Wear dry, hole-free insulating gloves and body protection.
- Insulate yourself from work and ground using dry insulating mats or covers big enough to prevent any physical contact with the work or ground.
- Do not use AC weld output in damp, wet, or confined spaces, or if there is a danger of falling.
- Use AC output ONLY if required for the welding process.
- If AC output is required, use remote output control if present on unit.
- Additional safety precautions are required when any of the following electrically hazardous conditions are present: in damp locations or while wearing wet clothing; on metal structures such as floors, gratings, or scaffolds; when in cramped positions such as sitting, kneeling, or lying; or when there is a high risk of unavoidable or accidental contact with the workpiece or ground. For these conditions, use the following equipment in order presented: 1) a semiautomatic DC constant voltage (wire) welder, 2) a DC manual (stick) welder, or 3) an AC welder with reduced open-circuit voltage. In most situations, use of a DC, constant voltage wire welder is recommended. And, do not work alone!
- Do not connect to any electrical distribution system normally supplied by utility power unless a proper transfer switch and grounding procedure are employed.

 Indicates special instructions.



This group of symbols means Warning! Watch Out! ELECTRIC SHOCK, MOVING PARTS, and HOT PARTS hazards. Consult symbols and related instructions below for necessary actions to avoid the hazards.

- Disconnect input power or stop engine before installing or servicing this equipment. Lockout/tagout input power according to OSHA 29 CFR 1910.147 (see Safety Standards).
- Properly install, ground, and operate this equipment according to its Owner's Manual and national, state, and local codes.
- Always verify the supply ground — check and be sure that input power cord ground wire is properly connected to ground terminal in disconnect box or that cord plug is connected to a properly grounded receptacle outlet.
- When making input connections, attach proper grounding conductor first — double-check connections.
- Keep cords dry, free of oil and grease, and protected from hot metal and sparks.
- Frequently inspect input power cord and ground conductor for damage or bare wiring — replace immediately if damaged — bare wiring can kill.
- Turn off all equipment when not in use.
- Do not use worn, damaged, undersized, or repaired cables.
- Do not drape cables over your body.
- If earth grounding of the workpiece is required, ground it directly with a separate cable.
- Do not touch electrode if you are in contact with the work, ground, or another electrode from a different machine.
- Use only well-maintained equipment. Repair or replace damaged parts at once. Maintain unit according to manual.
- Do not touch electrode holders connected to two welding machines at the same time since double open-circuit voltage will be present.
- Wear a safety harness if working above floor level.
- Keep all panels and covers securely in place.
- Clamp work cable with good metal-to-metal contact to workpiece or worktable as near the weld as practical.
- Insulate work clamp when not connected to workpiece to prevent contact with any metal object.
- Do not connect more than one electrode or work cable to any single weld output terminal. Disconnect cable for process not in use.
- Use GFCI protection when operating auxiliary equipment. Test GFCI receptacles at high speed.

### SIGNIFICANT DC VOLTAGE exists in inverter power sources AFTER stopping engine.

- Stop engine on inverter and discharge input capacitors according to instructions in Manual before touching any parts.



### HOT PARTS can burn.

- Do not touch hot parts bare handed.
- Allow cooling period before working on equipment.
- To handle hot parts, use proper tools and/or wear heavy, insulated welding gloves and clothing to prevent burns.

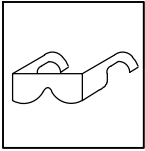

### **FLYING METAL or DIRT can injure eyes.**

- Welding, chipping, wire brushing, and grinding cause sparks and flying metal. As welds cool, they can throw off slag.

- Wear approved safety glasses with side shields even under your welding helmet.



### **FUMES AND GASES can be hazardous.**

Welding produces fumes and gases. Breathing these fumes and gases can be hazardous to your health.

- Keep your head out of the fumes. Do not breathe the fumes.
- Ventilate the work area and/or use local forced ventilation at the arc to remove welding fumes and gases. The recommended way to determine adequate ventilation is to sample for the composition and quantity of fumes and gases to which personnel are exposed.
- If ventilation is poor, wear an approved air-supplied respirator.
- Read and understand the Safety Data Sheets (SDSs) and the manufacturer's instructions for adhesives, coatings, cleaners, consumables, coolants, degreasers, fluxes, and metals.
- Work in a confined space only if it is well ventilated, or while wearing an air-supplied respirator. Always have a trained watchperson nearby. Welding fumes and gases can displace air and lower the oxygen level causing injury or death. Be sure the breathing air is safe.
- Do not weld in locations near degreasing, cleaning, or spraying operations. The heat and rays of the arc can react with vapors to form highly toxic and irritating gases.
- Do not weld on coated metals, such as galvanized, lead, or cadmium plated steel, unless the coating is removed from the weld area, the area is well ventilated, and while wearing an air-supplied respirator. The coatings and any metals containing these elements can give off toxic fumes if welded.



### **BUILDUP OF GAS can injure or kill.**

- Shut off compressed gas supply when not in use.
- Always ventilate confined spaces or use approved air-supplied respirator.



### **ARC RAYS can burn eyes and skin.**

Arc rays from the welding process produce intense visible and invisible (ultraviolet and infrared) rays that can burn eyes and skin. Sparks fly off from the weld.

- Wear an approved welding helmet fitted with a proper shade of filter lenses to protect your face and eyes from arc rays and sparks when welding or watching (see ANSI Z49.1 and Z87.1 listed in Safety Standards).
- Wear approved safety glasses with side shields under your helmet.
- Use protective screens or barriers to protect others from flash, glare, and sparks; warn others not to watch the arc.
- Wear body protection made from durable, flame-resistant material (leather, heavy cotton, wool). Body protection includes oil-free clothing such as leather gloves, heavy shirt, cuffless trousers, high shoes, and a cap.



### **WELDING can cause fire or explosion.**

Welding on closed containers, such as tanks, drums, or pipes, can cause them to blow up. Sparks can fly off from the welding arc. The flying sparks, hot workpiece, and hot equipment can cause fires and burns. Accidental contact of electrode to metal objects can cause sparks, explosion, overheating, or fire. Check and be sure the area is safe before doing any welding.

- Remove all flammables within 35 ft (10.7 m) of the welding arc. If this is not possible, tightly cover them with approved covers.
- Do not weld where flying sparks can strike flammable material.
- Protect yourself and others from flying sparks and hot metal.
- Be alert that welding sparks and hot materials from welding can easily go through small cracks and openings to adjacent areas.

- Watch for fire, and keep a fire extinguisher nearby.
- Be aware that welding on a ceiling, floor, bulkhead, or partition can cause fire on the hidden side.
- Do not cut or weld on tire rims or wheels. Tires can explode if heated. Repaired rims and wheels can fail. See OSHA 29 CFR 1910.177 listed in Safety Standards.
- Do not weld on containers that have held combustibles, or on closed containers such as tanks, drums, or pipes unless they are properly prepared according to AWS F4.1 and AWS A6.0 (see Safety Standards).
- Do not weld where the atmosphere can contain flammable dust, gas, or liquid vapors (such as gasoline).
- Connect work cable to the work as close to the welding area as practical to prevent welding current from traveling long, possibly unknown paths and causing electric shock, sparks, and fire hazards.
- Do not use welder to thaw frozen pipes.
- Remove stick electrode from holder or cut off welding wire at contact tip when not in use.
- Wear body protection made from durable, flame-resistant material (leather, heavy cotton, wool). Body protection includes oil-free clothing such as leather gloves, heavy shirt, cuffless trousers, high shoes, and a cap.
- Remove any combustibles, such as a butane lighter or matches, from your person before doing any welding.
- After completion of work, inspect area to ensure it is free of sparks, glowing embers, and flames.
- Use only correct fuses or circuit breakers. Do not oversize or bypass them.
- Follow requirements in OSHA 1910.252 (a) (2) (iv) and NFPA 51B for hot work and have a fire watcher and extinguisher nearby.
- Read and understand the Safety Data Sheets (SDSs) and the manufacturer's instructions for adhesives, coatings, cleaners, consumables, coolants, degreasers, fluxes, and metals.

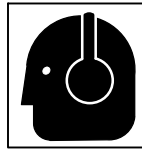

### **NOISE can damage hearing.**

Noise from some processes or equipment can damage hearing.

- Wear approved ear protection if noise level is high.

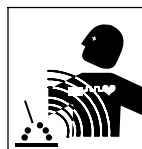

### **ELECTRIC AND MAGNETIC FIELDS (EMF) can affect Implanted Medical Devices.**

- Wearers of Pacemakers and other Implanted Medical Devices should keep away.
- Implanted Medical Device wearers should consult their doctor and the device manufacturer before going near arc welding, spot welding, gouging, plasma arc cutting, or induction heating operations.

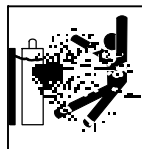

### **CYLINDERS can explode if damaged.**

Compressed gas cylinders contain gas under high pressure. If damaged, a cylinder can explode. Since gas cylinders are normally part of the welding process, be sure to treat them carefully.

- Protect compressed gas cylinders from excessive heat, mechanical shocks, physical damage, slag, open flames, sparks, and arcs.
- Install cylinders in an upright position by securing to a stationary support or cylinder rack to prevent falling or tipping.
- Keep cylinders away from any welding or other electrical circuits.
- Never drape a welding torch over a gas cylinder.
- Never allow a welding electrode to touch any cylinder.
- Never weld on a pressurized cylinder — explosion will result.
- Use only correct compressed gas cylinders, regulators, hoses, and fittings designed for the specific application; maintain them and associated parts in good condition.
- Turn face away from valve outlet when opening cylinder valve. Do not stand in front of or behind the regulator when opening the valve.
- Keep protective cap in place over valve except when cylinder is in use or connected for use.
- Use the proper equipment, correct procedures, and sufficient number of persons to lift, move, and transport cylinders.
- Read and follow instructions on compressed gas cylinders, associated equipment, and Compressed Gas Association (CGA) publication P-1 listed in Safety Standards.

## 1-3. Engine Hazards



### BATTERY EXPLOSION can injure.

- Always wear a face shield, rubber gloves, and protective clothing when working on a battery.
- Stop engine before disconnecting or connecting battery cables, battery charging cables (if applicable), or servicing battery.
- Do not allow tools to cause sparks when working on a battery.
- Do not use welder to charge batteries or jump start vehicles unless the unit has a battery charging feature designed for this purpose.
- Observe correct polarity (+ and -) on batteries.
- Disconnect negative (-) cable first and connect it last.
- Keep sparks, flames, cigarettes, and other ignition sources away from batteries. Batteries produce explosive gases during normal operation and when being charged.
- Follow battery manufacturer's instructions when working on or near a battery. See Battery Service Manual (listed in Safety Standards) for additional information.



### FUEL can cause fire or explosion.

- Stop engine and let it cool off before checking or adding fuel.
- Do not add fuel while smoking or if unit is near any sparks or open flames.
- Do not overfill tank — allow room for fuel to expand.
- Do not spill fuel. If fuel is spilled, clean up before starting engine.
- Dispose of rags in a fireproof container.
- Always keep nozzle in contact with tank when fueling.



### MOVING PARTS can injure.

- Keep away from moving parts such as fans, belts, and rotors.
- Keep all doors, panels, covers, and guards closed and securely in place.
- Stop engine before installing or connecting unit.
- Have only qualified persons remove doors, panels, covers, or guards for maintenance and troubleshooting as necessary.
- To prevent accidental starting during servicing, disconnect negative (-) battery cable from battery.
- Keep hands, hair, loose clothing, and tools away from moving parts.
- Reinstall doors, panels, covers, or guards when servicing is finished and before starting engine.
- Before working on generator, remove spark plugs or injectors to keep engine from kicking back or starting.
- Block flywheel so that it will not turn while working on generator components.



### EXHAUST SPARKS can cause fire.

- Do not let engine exhaust sparks cause fire.
- Use approved engine exhaust spark arrestor in required areas — see applicable codes.



### HOT PARTS can burn.

- Do not touch hot parts bare handed.
- Allow cooling period before working on equipment.
- To handle hot parts, use proper tools and/or wear heavy, insulated welding gloves and clothing to prevent burns.

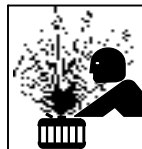

### STEAM AND HOT COOLANT can burn.

- If possible, check coolant level when engine is cold to avoid scalding.
- Always check coolant level at overflow tank, if present on unit, instead of radiator (unless told otherwise in maintenance section or engine manual).
- If the engine is warm, checking is needed, and there is no overflow tank, follow the next two statements.
- Wear safety glasses and gloves and put a rag over radiator cap.
- Turn cap slightly and let pressure escape slowly before completely removing cap.

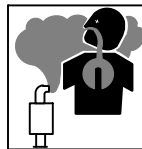

### Using a generator indoors CAN KILL YOU IN MINUTES.

- Generator exhaust contains carbon monoxide. This is a poison you cannot see or smell.
- NEVER use inside a home or garage, EVEN IF doors and windows are open.
- Only use OUTSIDE and far away from windows, doors, and vents.

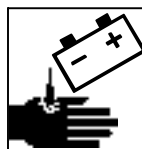

### BATTERY ACID can BURN SKIN and EYES.

- Do not tip battery.
- Replace damaged battery.
- Flush eyes and skin immediately with water.



### ENGINE HEAT can cause fire.

- Do not locate unit on, over, or near combustible surfaces or flammables.
- Keep exhaust and exhaust pipes way from flammables.

## 1-4. Compressed Air Hazards



### COMPRESSED AIR EQUIPMENT can injure or kill.

- Incorrect installation or operation of this unit could result in equipment failure and personal injury. Only qualified persons should install, operate, and service this unit according to its Owner's Manual, industry standards, and national, state, and local codes.
- Do not exceed the rated output or capacity of the compressor or any equipment in the compressed air system. Design compressed air system so failure of any component will not put people or property at risk.
- Before working on compressed air system, turn off and lockout/tagout unit, release pressure, and be sure air pressure cannot be accidentally applied.
- Do not work on compressed air system with unit running unless you are a qualified person and following the manufacturer's instructions.
- Do not modify or alter compressor or manufacturer-supplied equipment. Do not disconnect, disable, or override any safety equipment in the compressed air system.
- Use only components and accessories approved by the manufacturer.
- Keep away from potential pinch points or crush points created by equipment connected to the compressed air system.
- Do not work under or around any equipment that is supported only by air pressure. Properly support equipment by mechanical means.



### **HOT METAL from air arc cutting and gouging can cause fire or explosion.**

- Do not cut or gouge near flammables.
- Watch for fire; keep extinguisher nearby.



### **COMPRESSED AIR can injure or kill.**

- Before working on compressed air system, turn off and lockout/tagout unit, release pressure, and be sure air pressure cannot be accidentally applied.
- Relieve pressure before disconnecting or connecting air lines.
- Check compressed air system components and all connections and hoses for damage, leaks, and wear before operating unit.



- Do not direct air stream toward self or others.
- Wear protective equipment such as safety glasses, hearing protection, leather gloves, heavy shirt and trousers, high shoes, and a cap when working on compressed air system.
- Use soapy water or an ultrasonic detector to search for leaks--never use bare hands. Do not use equipment if leaks are found.
- Reinstall doors, panels, covers, or guards when servicing is finished and before starting unit.
- If ANY air is injected into the skin or body seek medical help immediately.



### **BREATHING COMPRESSED AIR can injure or kill.**

- Do not use compressed air for breathing.
- Use only for cutting, gouging, and tools.



### **TRAPPED AIR PRESSURE AND WHIPPING HOSES can injure.**

- Release air pressure from tools and system before servicing, adding or changing attachments, or opening compressor oil drain or oil fill cap.



### **MOVING PARTS can injure.**

- Keep away from moving parts such as fans, belts and rotors.
- Keep all doors, panels, covers, and guards closed and securely in place.

- Keep hands, hair, loose clothing, and tools away from moving parts.
- Before working on compressed air system, turn off and lockout/tagout unit, release pressure, and be sure air pressure cannot be accidentally applied.
- Have only qualified people remove guards or covers for maintenance and troubleshooting as necessary.
- Reinstall doors, panels, covers, or guards when servicing is finished and before starting engine.



### **HOT PARTS can burn.**

- Do not touch hot compressor or air system parts.
- Allow cooling period before working on equipment.

- To handle hot parts, use proper tools and/or wear heavy, insulated welding gloves and clothing to prevent burns.

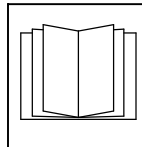

### **READ INSTRUCTIONS.**

- Read and follow all labels and the Owner's Manual carefully before installing, operating, or servicing unit. Read the safety information at the beginning of the manual and in each section.

- Use only genuine replacement parts from the manufacturer.
- Perform installation, maintenance, and service according to the Owner's Manuals, industry standards, and national, state, and local codes.

## **1-5. Additional Symbols For Installation, Operation, And Maintenance**



### **FIRE OR EXPLOSION hazard.**

- Do not install or place unit on, over, or near combustible surfaces.
- Do not install unit near flammables.
- Do not overload building wiring – be sure power supply system is properly sized, rated, and protected to handle this unit.



### **FALLING EQUIPMENT can injure.**

- Use lifting eye to lift unit and properly installed accessories only, NOT gas cylinders. Do not exceed maximum lift eye weight rating (see Specifications).
- Use correct procedures and equipment of adequate capacity to lift and support unit.
- If using lift forks to move unit, be sure forks are long enough to extend beyond opposite side of unit.
- Keep equipment (cables and cords) away from moving vehicles when working from an aerial location.
- Follow the guidelines in the Applications Manual for the Revised NIOSH Lifting Equation (Publication No. 94-110) when manually lifting heavy parts or equipment.

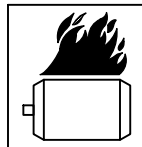

### **OVERHEATING can damage motors.**

- Turn off or unplug equipment before starting or stopping engine.
- Do not let low voltage and frequency caused by low engine speed damage electric motors.

- Use only equipment suitable for operation on 60 or 50/60 Hz power.

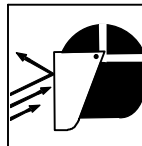

### **FLYING SPARKS can injure.**

- Wear a face shield to protect eyes and face.
- Shape tungsten electrode only on grinder with proper guards in a safe location wearing proper face, hand, and body protection.

- Sparks can cause fires — keep flammables away.

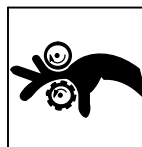

### **MOVING PARTS can injure.**

- Keep away from moving parts.
- Keep away from pinch points such as drive rolls.



### BATTERY CHARGING OUTPUT and BATTERY EXPLOSION can injure.

Battery charging not present on all models.

- Always wear a face shield, rubber gloves, and protective clothing when working on a battery.
- Stop engine before disconnecting or connecting battery cables, battery charging cables (if applicable), or servicing battery.
- Do not allow tools to cause sparks when working on a battery.
- Do not use welder to charge batteries or jump start vehicles unless it has a battery charging feature designed for this purpose.
- Observe correct polarity (+ and -) on batteries.
- Disconnect negative (-) cable first and connect it last.
- Keep sparks, flames, cigarettes, and other ignition sources away from batteries. Batteries produce explosive gases during normal operation and when being charged.
- Follow battery manufacturer's instructions when working on or near a battery. See Battery Service Manual (listed in Safety Standards) for additional information.
- Have only qualified persons do battery charging work.
- If battery is being removed from a vehicle for charging, disconnect negative (-) cable first and connect it last. To prevent an arc, make sure all accessories are off.
- Charge lead-acid batteries only. Do not use battery charger to supply power to an extra-low-voltage electrical system or to charge dry cell batteries.
- Do not charge a frozen battery.
- Do not use damaged charging cables.
- Do not charge batteries in a closed area or where ventilation is restricted.
- Do not charge a battery that has loose terminals or one showing damage such as a cracked case or cover.
- Before charging battery, select correct charger voltage to match battery voltage.
- Set battery charging controls to the Off position before connecting to battery. Do not allow battery charging clips to touch each other.
- Keep charging cables away from vehicle hood, door, or moving parts.



### HIGH PRESSURE FLUIDS can injure or kill.

- Engine fuel system components can be under high pressure.
- Before working on fuel system, turn off engine to release pressure.
- If any fluid is injected into the skin or body seek medical help immediately.



### WELDING WIRE can injure.

- Do not press gun trigger until instructed to do so.
- Do not point gun toward any part of the body, other people, or any metal when threading welding wire.

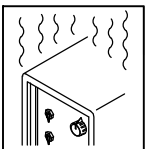

### OVERUSE can cause OVERHEATING.

- Allow cooling period; follow rated duty cycle.
- Reduce current or reduce duty cycle before starting to weld again.
- Do not block or filter airflow to unit.

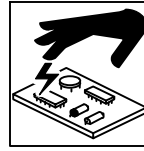

### STATIC (ESD) can damage PC boards.

- Put on grounded wrist strap BEFORE handling boards or parts.
- Use proper static-proof bags and boxes to store, move, or ship PC boards.

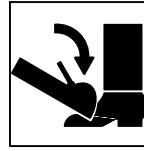

### TILTING OF TRAILER can injure.

- Use tongue jack or blocks to support weight.
- Properly install welding generator onto trailer according to instructions supplied with trailer.

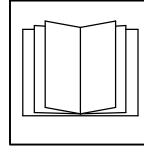

### READ INSTRUCTIONS.

- Read and follow all labels and the Owner's Manual carefully before installing, operating, or servicing unit. Read the safety information at the beginning of the manual and in each section.
- Use only genuine replacement parts from the manufacturer.
- Perform installation, maintenance, and service according to the Owner's Manuals, industry standards, and national, state, and local codes.

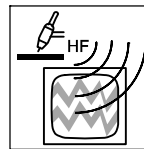

### H.F. RADIATION can cause interference.

- High-frequency (H.F.) can interfere with radio navigation, safety services, computers, and communications equipment.
- Have only qualified persons familiar with electronic equipment perform this installation.
- The user is responsible for having a qualified electrician promptly correct any interference problem resulting from the installation.
- If notified by the FCC about interference, stop using the equipment at once.
- Have the installation regularly checked and maintained.
- Keep high-frequency source doors and panels tightly shut, keep spark gaps at correct setting, and use grounding and shielding to minimize the possibility of interference.

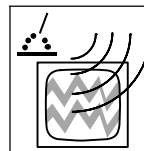

### ARC WELDING can cause interference.

- Electromagnetic energy can interfere with sensitive electronic equipment such as micro-processors, computers, and computer-driven equipment such as robots.
- Be sure all equipment in the welding area is electromagnetically compatible.
- To reduce possible interference, keep weld cables as short as possible, close together, and down low, such as on the floor.
- Locate welding operation 100 meters from any sensitive electronic equipment.
- Be sure this welding machine is installed and grounded according to this manual.
- If interference still occurs, the user must take extra measures such as moving the welding machine, using shielded cables, using line filters, or shielding the work area.

## 1-6. California Proposition 65 Warnings

**⚠ WARNING:** This product can expose you to chemicals including lead, which are known to the state of California to cause cancer and birth defects or other reproductive harm.

For more information, go to [www.P65Warnings.ca.gov](http://www.P65Warnings.ca.gov).

### For Diesel Engines:

**⚠ WARNING:** Breathing diesel engine exhaust exposes you to chemicals known to the state of California to cause cancer and birth defects or other reproductive harm.

- Always start and operate the engine in a well-ventilated area.
- If in an enclosed area, vent the exhaust to the outside.
- Do not modify or tamper with the exhaust system.
- Do not idle the engine except as necessary.

For more information, go to [www.P65Warnings.ca.gov/diesel](http://www.P65Warnings.ca.gov/diesel).

## 1-7. Principal Safety Standards

*Safety in Welding, Cutting, and Allied Processes*, ANSI Standard Z49.1, is available as a free download from the American Welding Society at <http://www.aws.org> or purchased from Global Engineering Documents (phone: 1-877-413-5184, website: [www.global.ihs.com](http://www.global.ihs.com)).

*Safe Practices for the Preparation of Containers and Piping for Welding and Cutting*, American Welding Society Standard AWS F4.1, from Global Engineering Documents (phone: 1-877-413-5184, website: [www.global.ihs.com](http://www.global.ihs.com)).

*Safe Practices for Welding and Cutting Containers that have Held Combustibles*, American Welding Society Standard AWS A6.0, from Global Engineering Documents (phone: 1-877-413-5184, website: [www.global.ihs.com](http://www.global.ihs.com)).

*National Electrical Code*, NFPA Standard 70, from National Fire Protection Association, Quincy, MA 02169 (phone: 1-800-344-3555, website: [www.nfpa.org](http://www.nfpa.org) and [www.sparky.org](http://www.sparky.org)).

*Safe Handling of Compressed Gases in Cylinders*, CGA Pamphlet P-1, from Compressed Gas Association, 14501 George Carter Way, Suite 103, Chantilly, VA 20151 (phone: 703-788-2700, website: [www.cganet.com](http://www.cganet.com)).

*Safety in Welding, Cutting, and Allied Processes*, CSA Standard W117.2, from Canadian Standards Association, Standards Sales, 5060 Spectrum Way, Suite 100, Mississauga, Ontario, Canada L4W 5N5 (phone: 800-463-6727, website: [www.csagroup.org](http://www.csagroup.org)).

*Battery Chargers*, CSA Standard C22.2 NO 107.2-01, from Canadian Standards Association, Standards Sales, 5060 Spectrum Way, Suite 100, Mississauga, Ontario, Canada L4W 5N5 (phone: 800-463-6727, website: [www.csagroup.org](http://www.csagroup.org)).

*Safe Practice For Occupational And Educational Eye And Face Protection*, ANSI Standard Z87.1, from American National Standards Institute, 25 West 43rd Street, New York, NY 10036 (phone: 212-642-4900, website: [www.ansi.org](http://www.ansi.org)).

*Standard for Fire Prevention During Welding, Cutting, and Other Hot Work*, NFPA Standard 51B, from National Fire Protection Association, Quincy, MA 02169 (phone: 1-800-344-3555, website: [www.nfpa.org](http://www.nfpa.org)).

OSHA, Occupational Safety and Health Standards for General Industry, Title 29, Code of Federal Regulations (CFR), Part 1910.177 Subpart N, Part 1910 Subpart Q, and Part 1926, Subpart J, from U.S. Government Printing Office, Superintendent of Documents, P.O. Box 371954, Pittsburgh, PA 15250-7954 (phone: 1-866-512-1800) (there are 10 OSHA Regional Offices—phone for Region 5, Chicago, is 312-353-2220, website: [www.osha.gov](http://www.osha.gov)).

*Portable Generators Safety Alert*, U.S. Consumer Product Safety Commission (CPSC), 4330 East West Highway, Bethesda, MD 20814 (phone: 301-504-7923, website: [www.cpsc.gov](http://www.cpsc.gov)).

*Applications Manual for the Revised NIOSH Lifting Equation*, The National Institute for Occupational Safety and Health (NIOSH), 1600 Clifton Rd, Atlanta, GA 30329-4027 (phone: 1-800-232-4636, website: [www.cdc.gov/NIOSH](http://www.cdc.gov/NIOSH)).

For Standards regulating hydraulic systems, contact the National Fluid Power Association, 6737 West Washington St., Suite 2350, Milwaukee, WI 53214 (phone: (414) 778-3344, website: [www.nfpa.com](http://www.nfpa.com)).

*Battery Service Manual*, Battery Council International, 330 North Wabash Ave., Suite 2000, Chicago IL 60611 (phone: 1-312-245-1074, website: [www.batterycouncil.org](http://www.batterycouncil.org)).

## 1-8. EMF Information

Electric current flowing through any conductor causes localized electric and magnetic fields (EMF). The current from arc welding (and allied processes including spot welding, gouging, plasma arc cutting, and induction heating operations) creates an EMF field around the welding circuit. EMF fields can interfere with some medical implants, e.g. pacemakers. Protective measures for persons wearing medical implants have to be taken. For example, restrict access for passers-by or conduct individual risk assessment for welders. All welders should use the following procedures in order to minimize exposure to EMF fields from the welding circuit:

1. Keep cables close together by twisting or taping them, or using a cable cover.
2. Do not place your body between welding cables. Arrange cables to one side and away from the operator.
3. Do not coil or drape cables around your body.

4. Keep head and trunk as far away from the equipment in the welding circuit as possible.
5. Connect work clamp to workpiece as close to the weld as possible.
6. Do not work next to, sit or lean on the welding power source.
7. Do not weld whilst carrying the welding power source or wire feeder.

### About Implanted Medical Devices:

Implanted Medical Device wearers should consult their doctor and the device manufacturer before performing or going near arc welding, spot welding, gouging, plasma arc cutting, or induction heating operations. If cleared by your doctor, then following the above procedures is recommended.

# SECTION 2 – CONSIGNES DE SÉCURITÉ – LIRE AVANT UTILISATION

rom\_2018-06\_fre

**⚠** Pour écarter les risques de blessure pour vous-même et pour autrui — lire, appliquer et ranger en lieu sûr ces consignes relatives aux précautions de sécurité et au mode opératoire.

## 2-1. Signification des symboles



**DANGER!** – Indique une situation dangereuse qui si on l'évite pas peut donner la mort ou des blessures graves. Les dangers possibles sont montrés par les symboles joints ou sont expliqués dans le texte.



Indique une situation dangereuse qui si on l'évite pas peut donner la mort ou des blessures graves. Les dangers possibles sont montrés par les symboles joints ou sont expliqués dans le texte.

**AVIS** – Indique des déclarations pas en relation avec des blessures personnelles.

Indique des instructions spécifiques.



Ce groupe de symboles veut dire Avertissement! Attention! DANGER DE CHOC ELECTRIQUE, PIECES EN MOUVEMENT, et PIECES CHAUDES. Consulter les symboles et les instructions ci-dessous y afférant pour les actions nécessaires afin d'éviter le danger.

## 2-2. Dangers relatifs au soudage à l'arc



Les symboles présentés ci-après sont utilisés tout au long du présent manuel pour attirer votre attention et identifier les risques de danger. Lorsque vous voyez un symbole, soyez vigilant et suivez les directives mentionnées afin d'éviter tout danger. Les consignes de sécurité présentées ci-après ne font que résumer l'information contenue dans les normes de sécurité énumérées à la section 2-7. Veuillez lire et respecter toutes ces normes de sécurité.



L'installation, l'utilisation, l'entretien et les réparations ne doivent être confiés qu'à des personnes qualifiées. Une personne qualifiée est définie comme celle qui, par la possession d'un diplôme reconnu, d'un certificat ou d'un statut professionnel, ou qui, par une connaissance, une formation et une expérience approfondies, a démontré avec succès sa capacité à résoudre les problèmes liés à la tâche, le travail ou le projet et a reçu une formation en sécurité afin de reconnaître et d'éviter les risques inhérents.



Au cours de l'utilisation, tenir toute personne à l'écart et plus particulièrement les enfants.



### UN CHOC ÉLECTRIQUE peut tuer.

Un simple contact avec des pièces électriques peut provoquer une électrocution ou des blessures graves. L'électrode et le circuit de soudage sont sous tension dès que l'appareil est sur ON. Le circuit d'entrée et les circuits internes de l'appareil sont également sous tension à ce moment-là. En soudage semi-automatique ou automatique, le fil, le dévidoir, le logement des galets d'entraînement et les pièces métalliques en contact avec le fil de soudage sont sous tension. Des matériels mal installés ou mal mis à la terre présentent un danger.

- Ne jamais toucher les pièces électriques sous tension.
- Porter des gants et des vêtements de protection secs ne comportant pas de trous.
- S'isoler de la pièce et de la terre au moyen de tapis ou d'autres moyens isolants suffisamment grands pour empêcher le contact physique éventuel avec la pièce ou la terre.
- Ne pas utiliser de sortie de soudage CA dans des zones humides ou confinées ou s'il y a un risque de chute.
- Se servir d'une source électrique à courant électrique UNIQUEMENT si le procédé de soudage le demande.
- Si l'utilisation d'une source électrique à courant électrique s'avère nécessaire, se servir de la fonction de télécommande si l'appareil en est équipé.
- Des précautions de sécurité supplémentaires sont requises dans des environnements à risque comme: les endroits humides ou lorsque l'on porte des vêtements mouillés; sur des structures métalliques au sol, grillages et échafaudages; dans des positions assises, à genoux et allongées; ou quand il y a un risque important de contact accidentel avec la pièce ou le sol. Dans ces cas utiliser les appareils suivants dans l'ordre de préférence: 1) un poste à souder DC semi-automatique de type CV (MIG/MAG), 2) un poste à souder manuel (électrode enrobée) DC, 3) un poste à souder manuel AC avec tension à vide réduite. Dans la plupart des cas, un poste courant continu de type CV est recommandé. Et, ne pas travailler seul!
- Ne brancher aucun système de distribution électrique normalement fourni par un réseau public à moins qu'un commutateur de transfert et une procédure de mise à la terre adéquats ne soient mis en place.
- Couper l'alimentation ou arrêter le moteur avant de procéder à l'installation, à la réparation ou à l'entretien de l'appareil. Déverrouiller l'alimentation selon la norme OSHA 29 CFR 1910.147 (voir normes de sécurité).
- Installer et mettre à la terre correctement cet appareil conformément à son manuel d'utilisation et aux codes nationaux, provinciaux et municipaux.
- Toujours vérifier la terre du cordon d'alimentation – Vérifier et s'assurer que le fil de terre du cordon d'alimentation est bien raccordé à la borne de terre du sectionneur ou que la fiche du cordon est raccordée à une prise correctement mise à la terre.
- En effectuant les raccordements d'entrée fixer d'abord le conducteur de mise à la terre approprié et contre-vérifier les connexions.
- Les câbles doivent être exempts d'humidité, d'huile et de graisse; protégez-les contre les étincelles et les pièces métalliques chaudes.
- Vérifier fréquemment le cordon d'alimentation et le conducteur de mise à la terre afin de s'assurer qu'il n'est pas altéré ou dénudé –, le remplacer immédiatement s'il l'est –, un fil dénudé peut entraîner la mort.
- Mettre l'appareil hors tension quand on ne l'utilise pas.
- Ne pas utiliser des câbles usés, endommagés, sous dimensionnés ou réparés.
- Ne pas enrouler les câbles autour du corps.
- Si la pièce soudée doit être mise à la terre, le faire directement avec un câble distinct – ne pas utiliser le connecteur de pièce ou le câble de retour.
- Ne pas toucher l'électrode quand on est en contact avec la pièce, la terre ou une électrode provenant d'une autre machine.
- Ne pas toucher des porte électrodes connectés à deux machines en même temps à cause de la présence d'une tension à vide doublée.
- N'utiliser qu'un matériel en bon état. Réparer ou remplacer sur-le-champ les pièces endommagées. Entretien l'appareil conformément à ce manuel.
- Ne pas toucher aux portes-électrodes qui sont raccordés à deux machines à souder en même temps, car cela entraîne la présence d'une tension de circuit-ouvert double.
- Porter un harnais de sécurité quand on travaille en hauteur.
- Maintenir solidement en place tous les panneaux et capots.

- Fixer le câble de retour de façon à obtenir un bon contact métal-métal avec la pièce à souder ou la table de travail, le plus près possible de la soudure.
- Isoler la pince de masse quand pas mis à la pièce pour éviter le contact avec tout objet métallique.
- Ne pas raccorder plus d'une électrode ou plus d'un câble de masse à une même borne de sortie de soudage. Débrancher le câble pour le procédé non utilisé.
- Utiliser une protection GFCI lors de l'utilisation d'appareils auxiliaires. Testez les prises GFCI à haute vitesse.

### Il reste une TENSION DC NON NÉGLIGEABLE dans les sources de soudage onduleur UNE FOIS le moteur coupé.

- Arrêtez le moteur sur l'onduleur et déchargez les condensateurs d'entrée conformément aux instructions du manuel avant de toucher les pièces.



### LES PIÈCES CHAUDES peuvent provoquer des brûlures.

- Ne pas toucher à mains nues les parties chaudes.
- Prévoir une période de refroidissement avant de travailler à l'équipement.
- Ne pas toucher aux pièces chaudes, utiliser les outils recommandés et porter des gants de soudage et des vêtements épais pour éviter les brûlures.

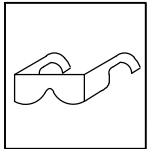

### DES PIÈCES DE METAL ou DES SALETES peuvent provoquer des blessures dans les yeux.

- Le soudage, l'écaillage, le passage de la pièce à la brosse en fil de fer, et le meulage génèrent des étincelles et des particules métalliques volantes. Pendant la période de refroidissement des soudures, elles risquent de projeter du laitier.
- Porter des lunettes de sécurité avec écrans latéraux ou un écran facial.



### LES FUMÉES ET LES GAZ peuvent être dangereux.

Le soudage génère des fumées et des gaz. Leur inhalation peut être dangereux pour votre santé.

- Eloigner votre tête des fumées. Ne pas respirer les fumées.
- À l'intérieur, ventiler la zone et/ou utiliser une ventilation forcée au niveau de l'arc pour l'évacuation des fumées et des gaz de soudage. Pour déterminer la bonne ventilation, il est recommandé de procéder à un prélèvement pour la composition et la quantité de fumées et de gaz auxquelles est exposé le personnel.
- Si la ventilation est médiocre, porter un respirateur anti-vapeurs approuvé.
- Lire et comprendre les fiches de données de sécurité et les instructions du fabricant concernant les adhésifs, les revêtements, les nettoyants, les consommables, les produits de refroidissement, les dégraisseurs, les flux et les métaux.
- Travailler dans un espace fermé seulement s'il est bien ventilé ou en portant un respirateur à alimentation d'air. Demander toujours à un surveillant dûment formé de se tenir à proximité. Des fumées et des gaz de soudage peuvent déplacer l'air et abaisser le niveau d'oxygène provoquant des blessures ou des accidents mortels. S'assurer que l'air de respiration ne présente aucun danger.
- Ne pas souder dans des endroits situés à proximité d'opérations de dégraissage, de nettoyage ou de pulvérisation. La chaleur et les rayons de l'arc peuvent réagir en présence de vapeurs et former des gaz hautement toxiques et irritants.
- Ne pas souder des métaux munis d'un revêtement, tels que l'acier galvanisé, plaqué en plomb ou au cadmium à moins que le revêtement n'ait été enlevé dans la zone de soudure, que l'endroit soit bien ventilé, et en portant un respirateur à alimentation d'air. Les revêtements et tous les métaux renfermant ces éléments peuvent dégager des fumées toxiques en cas de soudage.



### LES ACCUMULATIONS DE GAZ risquent de provoquer des blessures ou même la mort.

- Fermer l'alimentation du gaz comprimé en cas de non utilisation.
- Veiller toujours à bien aérer les espaces confinés ou se servir d'un respirateur d'adduction d'air homologué.

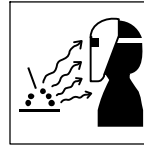

### LES RAYONS DE L'ARC peuvent provoquer des brûlures dans les yeux et sur la peau.

Le rayonnement de l'arc du procédé de soudage génère des rayons visibles et invisibles intenses (ultraviolets et infrarouges) susceptibles de provoquer des brûlures dans les yeux et sur la peau. Des étincelles sont projetées pendant le soudage.

- Porter un casque de soudage approuvé muni de verres filtrants approprié pour protéger visage et yeux pour protéger votre visage et vos yeux pendant le soudage ou pour regarder (voir ANSI Z49.1 et Z87.1 énuméré dans les normes de sécurité).
- Porter des lunettes de sécurité avec écrans latéraux même sous votre casque.
- Avoir recours à des écrans protecteurs ou à des rideaux pour protéger les autres contre les rayonnements les éblouissements et les étincelles ; prévenir toute personne sur les lieux de ne pas regarder l'arc.
- Porter un équipement de protection pour le corps fait d'un matériau résistant et ignifuge (cuir, coton robuste, laine). La protection du corps comporte des vêtements sans huile comme par ex. des gants de cuir, une chemise solide, des pantalons sans revers, des chaussures hautes et une casquette.



### LE SOUDAGE peut provoquer un incendie ou une explosion.

Le soudage effectué sur des conteneurs fermés tels que des réservoirs, tambours ou des conduites peut provoquer leur éclatement. Des étincelles peuvent être projetées de l'arc de soudure. La projection d'étincelles, des pièces chaudes et des équipements chauds peut provoquer des incendies et des brûlures. Le contact accidentel de l'électrode avec des objets métalliques peut provoquer des étincelles, une explosion, un surchauffement ou un incendie. Avant de commencer le soudage, vérifier et s'assurer que l'endroit ne présente pas de danger.

- Déplacer toutes les substances inflammables à une distance de 10,7 m de l'arc de soudage. En cas d'impossibilité les recouvrir soigneusement avec des protections homologués.
- Ne pas souder dans un endroit là où des étincelles peuvent tomber sur des substances inflammables.
- Se protéger et d'autres personnes de la projection d'étincelles et de métal chaud.
- Des étincelles et des matériaux chauds du soudage peuvent facilement passer dans d'autres zones en traversant de petites fissures et des ouvertures.
- Surveiller tout déclenchement d'incendie et tenir un extincteur à proximité.
- Le soudage effectué sur un plafond, plancher, paroi ou séparation peut déclencher un incendie de l'autre côté.
- Ne pas effectuer le soudage sur des conteneurs fermés tels que des réservoirs, tambours, ou conduites, à moins qu'ils n'aient été préparés correctement conformément à AWS F4.1 et AWS A6.0 (voir les Normes de Sécurité).
- Ne pas souder là où l'air ambiant pourrait contenir des poussières, gaz ou émanations inflammables (vapeur d'essence, par exemple).
- Brancher le câble de masse sur la pièce le plus près possible de la zone de soudage pour éviter le transport du courant sur une longue distance par des chemins inconnus éventuels en provoquant des risques d'électrocution, d'étincelles et d'incendie.
- Ne pas utiliser le poste de soudage pour dégeler des conduites gelées.
- En cas de non utilisation, enlever la baguette d'électrode du porte-électrode ou couper le fil à la pointe de contact.

- Porter un équipement de protection pour le corps fait d'un matériau résistant et ignifuge (cuir, coton robuste, laine). La protection du corps comporte des vêtements sans huile comme par ex. des gants de cuir, une chemise solide, des pantalons sans revers, des chaussures hautes et une casquette.
- Avant de souder, retirer toute substance combustible de vos poches telles qu'un allumeur au butane ou des allumettes.
- Une fois le travail achevé, assurez-vous qu'il ne reste aucune trace d'étincelles incandescentes ni de flammes.
- Utiliser exclusivement des fusibles ou coupe-circuits appropriés. Ne pas augmenter leur puissance; ne pas les ponter.
- Suivre les recommandations dans OSHA 1910.252(a)(2)(iv) et NFPA 51B pour les travaux à chaud et avoir de la surveillance et un extincteur à proximité.
- Lire et comprendre les fiches de données de sécurité et les instructions du fabricant concernant les adhésifs, les revêtements, les nettoyeurs, les consommables, les produits de refroidissement, les dégraissateurs, les flux et les métaux.



### LE BRUIT peut affecter l'ouïe.

Le bruit des processus et des équipements peut affecter l'ouïe.

- Porter des protections approuvés pour les oreilles si le niveau sonore est trop élevé.



### Les CHAMPS ÉLECTROMAGNÉTIQUES (CEM) peuvent affecter les implants médicaux.

- Les porteurs de stimulateurs cardiaques et autres implants médicaux doivent rester à distance.
- Les porteurs d'implants médicaux doivent consulter leur médecin et le fabricant du dispositif avant de s'approcher de la zone où se déroule du soudage à l'arc, du soudage par points, du gougeage, de la découpe plasma ou une opération de chauffage par induction.

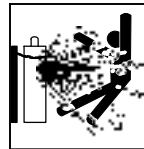

### Si des BOUTEILLES sont endommagées, elles pourront exploser.

Des bouteilles de gaz comprimé protecteur contiennent du gaz sous haute pression. Si une bouteille est endommagée, elle peut exploser. Du fait que les

bouteilles de gaz font normalement partie du procédé de soudage, les manipuler avec précaution.

- Protéger les bouteilles de gaz comprimé d'une chaleur excessive, des chocs mécaniques, des dommages physiques, du laitier, des flammes ouvertes, des étincelles et des arcs.
- Placer les bouteilles debout en les fixant dans un support stationnaire ou dans un porte-bouteilles pour les empêcher de tomber ou de se renverser.
- Tenir les bouteilles éloignées des circuits de soudage ou autres circuits électriques.
- Ne jamais placer une torche de soudage sur une bouteille à gaz.
- Une électrode de soudage ne doit jamais entrer en contact avec une bouteille.
- Ne jamais souder une bouteille pressurisée – risque d'explosion.
- Utiliser seulement des bouteilles de gaz comprimé, régulateurs, tuyaux et raccords convenables pour cette application spécifique; les maintenir ainsi que les éléments associés en bon état.
- Tourner le dos à la sortie de vanne lors de l'ouverture de la vanne de la bouteille. Ne pas se tenir devant ou derrière le régulateur lors de l'ouverture de la vanne.
- Maintenir le chapeau de protection sur la soupape, sauf en cas d'utilisation ou de branchement de la bouteille.
- Utilisez les équipements corrects, les bonnes procédures et suffisamment de personnes pour soulever, déplacer et transporter les bouteilles.
- Lire et suivre les instructions sur les bouteilles de gaz comprimé, l'équipement connexe et le dépliant P-1 de la CGA (Compressed Gas Association) mentionné dans les principales normes de sécurité.

## 2-3. Dangers existant en relation avec le moteur

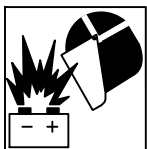

### L'EXPLOSION DE LA BATTERIE peut provoquer des blessures.

- Toujours porter une protection faciale, des gants en caoutchouc et vêtements de protection lors d'une intervention sur la batterie.
- Arrêter le moteur avant de débrancher ou de brancher des câbles de batterie, des câbles de chargeur de batterie (le cas échéant) ou de batterie d'entretien.
- Éviter de provoquer des étincelles avec les outils en travaillant sur la batterie.
- Ne pas utiliser l'appareil de soudage pour charger des batteries ou faire démarrer des véhicules à l'aide de câbles de démarrage, sauf si l'appareil dispose d'une fonctionnalité de charge de batterie destinée à cet usage.
- Observer la polarité correcte (+ et -) sur les batteries.
- Débrancher le câble négatif (-) en premier lieu. Le rebrancher en dernier lieu.
- Les sources d'étincelles, flammes nues, cigarettes et autres sources d'inflammation doivent être maintenues à l'écart des batteries. Ces dernières produisent des gaz explosifs en fonctionnement normal et en cours de charge.
- Suivre les instructions du fabricant de la batterie lors d'opérations sur une batterie ou à proximité de celle-ci. Voir le manuel de service de batterie (indiqué dans Normes de sécurité) pour plus d'informations.



### LE CARBURANT MOTEUR peut provoquer un incendie ou une explosion.

- Arrêter le moteur avant de vérifier le niveau de carburant ou de faire le plein.
- Ne pas faire le plein en fumant ou proche d'une source d'étincelles ou d'une flamme nue.
- Ne pas faire le plein de carburant à ras bord; prévoir de l'espace pour son expansion.
- Faire attention de ne pas renverser de carburant. Nettoyer tout carburant renversé avant de faire démarrer le moteur.
- Jeter les chiffons dans un récipient ignifuge.
- Toujours garder le pistolet en contact avec le réservoir lors du remplissage.



### Les PIÈCES MOBILES peuvent causer des blessures.

- S'abstenir de toucher des parties mobiles telles que des ventilateurs, courroies et rotors.
- Maintenir fermés et verrouillés les portes, panneaux, recouvrements et dispositifs de protection.
- Arrêter le moteur avant d'installer ou brancher l'appareil.
- Lorsque cela est nécessaire pour des travaux d'entretien et de dépannage, faire retirer les portes, panneaux, recouvrements ou dispositifs de protection uniquement par du personnel qualifié.
- Pour empêcher tout démarrage accidentel pendant les travaux d'entretien, débrancher le câble négatif (-) de batterie de la borne.

- Ne pas approcher les mains, cheveux, vêtements lâches et outils des organes mobiles.
- Remettre en place les portes, panneaux, recouvrements ou dispositifs de protection à la fin des travaux d'entretien et avant de mettre le moteur en marche.
- Avant d'intervenir, déposer les bougies ou injecteurs pour éviter la mise en route accidentelle du moteur.
- Bloquer le volant moteur pour éviter sa rotation lors d'une intervention sur le générateur.



### LES ÉTINCELLES À L'ÉCHAPPEMENT peuvent provoquer un incendie.

- Empêcher les étincelles d'échappement du moteur de provoquer un incendie.
- Utiliser uniquement un pare-étincelles approuvé – voir codes en vigueur.



### LES PIÈCES CHAUDES peuvent provoquer des brûlures.

- Ne pas toucher des parties chaudes à mains nues.
- Prévoir une période de refroidissement avant de travailler à l'équipement.
- Ne pas toucher aux pièces chaudes, utiliser les outils recommandés et porter des gants de soudage et des vêtements épais pour éviter les brûlures.

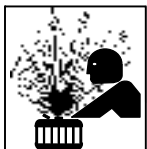

### LA VAPEUR ET LE LIQUIDE DE REFROIDISSEMENT CHAUD peuvent provoquer des brûlures.

- Il est préférable de vérifier le liquide de refroidissement une fois le moteur refroidi pour éviter de se brûler.
- Toujours vérifier le niveau de liquide de refroidissement dans le vase d'expansion (si présent), et non dans le radiateur (sauf si pré-

cisé autrement dans la section maintenance du manuel du moteur).

- Si le moteur est chaud et que le liquide doit être vérifié, opérer comme suivant.
- Mettre des lunettes de sécurité et des gants, placer un torchon sur le bouchon du radiateur.
- Dévisser le bouchon légèrement et laisser la vapeur s'échapper avant d'enlever le bouchon.

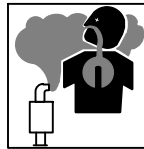

### L'utilisation d'un groupe autonome à l'intérieur PEUT VOUS TUER EN QUELQUES MINUTES.

- Les fumées d'un groupe autonome contient du monoxyde de carbone. C'est un poison invisible et inodore.
- JAMAIS utiliser dans une maison ou garage, même avec les portes et fenêtres ouvertes.
- Uniquement utiliser à l'EXTERIEUR, loin des portes, fenêtres et bouches aération.

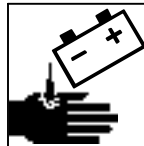

### L'ACIDE DE LA BATTERIE peut provoquer des brûlures dans les YEUX et sur la PEAU.

- Ne pas renverser la batterie.
- Remplacer une batterie endommagée.
- Rincer immédiatement les yeux et la peau à l'eau.



### LA CHALEUR DU MOTEUR peut provoquer un incendie.

- Ne pas placer l'appareil sur, au-dessus ou à proximité de surfaces inflammables.
- Tenir à distance les produits inflammables de l'échappement.

## 2-4. Dangers liés à l'air comprimé



### Un ÉQUIPEMENT PNEUMATIQUE risque de provoquer des blessures ou même la mort.

- Une installation ou une utilisation incorrecte de cet appareil pourrait conduire à des dégâts matériels ou corporels. Seul un personnel qualifié est autorisé à installer, utiliser et entretenir cet appareil conformément à son manuel d'utilisation, aux normes industrielles et aux codes nationaux, d'état ou locaux.
- Ne pas dépasser le débit nominal ou la capacité du compresseur ou de tout équipement du circuit d'air comprimé. Concevoir le circuit d'air comprimé de telle sorte que la défaillance d'un composant ne risque pas de provoquer un accident matériel ou corporel.
- Avant d'intervenir sur le circuit d'air comprimé, couper l'alimentation électrique, verrouiller et étiqueter l'appareil, détendre la pression et s'assurer que le circuit d'air ne peut être mis sous pression par inadvertance.
- Ne pas intervenir sur le circuit d'air comprimé lorsque l'appareil fonctionne. Seul un personnel qualifié est autorisé, et appliquant les consignes du fabricant.
- Ne pas modifier ou altérer le compresseur ou les équipements fournis par le fabricant. Ne pas débrancher, désactiver ou neutraliser les équipements de sécurité du circuit d'air comprimé.
- Utiliser uniquement des composants et accessoires homologués par le fabricant.
- Se tenir à l'écart de tout point présentant un danger de pincement ou d'écrasement créé par l'équipement raccordé au circuit d'air comprimé.
- Ne pas intervenir sous ou autour d'un équipement qui n'est soutenu que par la pression pneumatique. Soutenir l'équipement de façon appropriée par un moyen mécanique.



### MÉTAL CHAUD provenant du découpage ou du gougeage à l'arc risque de provoquer un incendie ou une explosion.

- Ne pas découper ou gouger à proximité de produits inflammables.
- Attention aux risques d'incendie: tenir un extincteur à proximité.



### L'AIR COMPRIMÉ risque de provoquer des blessures ou même la mort.



- Avant d'intervenir sur le circuit d'air comprimé, couper l'alimentation électrique, verrouiller et étiqueter l'appareil, détendre la pression et s'assurer que le circuit d'air ne peut être mis sous pression par inadvertance.
- Détendre la pression avant de débrancher ou de brancher des canalisations d'air.
- Avant d'utiliser l'appareil, contrôler les composants du circuit d'air comprimé, les branchements et les flexibles en recherchant tout signe de détérioration, de fuite et d'usure.
- Ne pas diriger un jet d'air vers soi-même ou vers autrui.
- Pour intervenir sur un circuit d'air comprimé, porter un équipement de protection tel que des lunettes de sécurité, des gants de cuir, une chemise et un pantalon en tissu résistant, des chaussures montantes et une coiffe.
- Pour rechercher des fuites, utiliser de l'eau savonneuse ou un détecteur à ultrasons, jamais les mains nues. En cas de détection de fuite, ne pas utiliser l'équipement.
- Remettre les portes, panneaux, recouvrements ou dispositifs de protection quand l'entretien est terminé et avant de mettre en marche l'appareil.
- En cas d'injection d'air dans la peau ou le corps, demander immédiatement une assistance médicale.



### L'INHALATION D'AIR COMPRIMÉ risque de provoquer des blessures ou même la mort.

- Ne pas inhaler d'air comprimé.
- Utiliser l'air comprimé uniquement pour découper ou gouger ainsi que pour l'outillage pneumatique.



### Une PRESSION D'AIR RÉSIDUELLE ET DES FLEXIBLES QUI FOUETTENT risquent de provoquer des blessures.

- Détendre la pression pneumatique des outils et circuits avant d'entretenir, ajouter ou changer des accessoires et avant d'ouvrir le bouchon de vidange ou de remplissage d'huile du compresseur.



### Les PIÈCES MOBILES peuvent causer des blessures.

- S'abstenir de toucher des parties mobiles telles que des ventilateurs, courroies et rotors.
- Maintenir fermés et verrouillés les portes, panneaux, recouvrements et dispositifs de protection.

- Ne pas approcher les mains, cheveux, vêtements lâches et outils des organes mobiles.
- Avant d'intervenir sur le circuit d'air comprimé, couper l'alimentation électrique, verrouiller et étiqueter l'appareil,

détendre la pression et s'assurer que le circuit d'air ne peut être mis sous pression par inadvertance.

- Demander seulement à un personnel qualifié d'enlever les dispositifs de sécurité ou les recouvrements pour effectuer, s'il y a lieu, des travaux d'entretien et de dépannage.
- Remettre en place les portes, panneaux, recouvrements ou dispositifs de protection à la fin des travaux d'entretien et avant de mettre le moteur en marche.



### DES PIÈCES CHAUDES peuvent provoquer des brûlures graves.

- Ne pas toucher de pièces chaudes du compresseur ou du circuit d'air.
- Prévoir une période de refroidissement avant d'intervenir sur l'équipement.
- Ne pas toucher aux pièces chaudes, utiliser les outils recommandés et porter des gants de soudage et des vêtements épais pour éviter les brûlures.

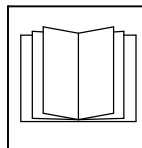

### LIRE LES INSTRUCTIONS.

- Lire et appliquer les instructions sur les étiquettes et le Mode d'emploi avant l'installation, l'utilisation ou l'entretien de l'appareil. Lire les informations de sécurité au début du manuel et dans chaque section.

- N'utiliser que les pièces de rechange recommandées par le constructeur.
- Effectuer l'installation, l'entretien et toute intervention selon les manuels d'utilisateurs, les normes nationales, provinciales et de l'industrie, ainsi que les codes municipaux.

## 2-5. Dangers supplémentaires en relation avec l'installation, le fonctionnement et la maintenance



### Risque D'INCENDIE OU D'EXPLOSION.

- Ne pas placer l'appareil sur, au-dessus ou à proximité de surfaces inflammables.
- Ne pas installer l'appareil à proximité de produits inflammables.
- Ne pas surcharger l'installation électrique – s'assurer que l'alimentation est correctement dimensionnée et protégée avant de mettre l'appareil en service.

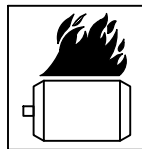

### LE SURCHAUFFEMENT peut endommager le moteur électrique.

- Arrêter ou déconnecter l'équipement avant de démarrer ou d'arrêter le moteur.
- Ne pas laisser tourner le moteur trop lentement sous risque d'endommager le moteur électrique à cause d'une tension et d'une fréquence trop faibles.
- Utiliser uniquement des équipements adéquats pour un fonctionnement avec une alimentation de 50/60 ou de 60 Hz.



### LA CHUTE DE L'ÉQUIPEMENT peut provoquer des blessures.

- Utiliser l'anneau de levage pour lever l'appareil et les accessoires correctement installés seuls, PAS les bouteilles de gaz. Ne pas dépasser le poids nominal maximal de l'ceilleton (voir les spécifications).
- Utilisez les procédures correctes et des équipements d'une capacité appropriée pour soulever et supporter l'appareil.
- En utilisant des fourches de levage pour déplacer l'unité, s'assurer que les fourches sont suffisamment longues pour dépasser du côté opposé de l'appareil.
- Tenir l'équipement (câbles et cordons) à distance des véhicules mobiles lors de toute opération en hauteur.
- Suivre les consignes du Manuel des applications pour l'équation de levage NIOSH révisée (Publication N°94-110) lors du levage manuelle de pièces ou équipements lourds.

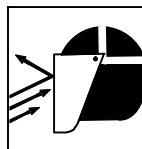

### LES ÉTINCELLES PROJETÉES peuvent provoquer des blessures.

- Porter un écran facial pour protéger le visage et les yeux.
- Affûter l'électrode au tungstène uniquement à la meuleuse dotée de protecteurs. Cette manœuvre est à exécuter dans un endroit sûr que l'on porte l'équipement homologué de protection du visage, des mains et du corps.
- Les étincelles risquent de causer un incendie – éloigner toute substance inflammable.

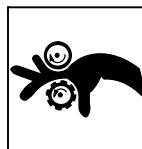

### Les PIÈCES MOBILES peuvent causer des blessures.

- Ne pas s'approcher des organes mobiles.
- Ne pas s'approcher des points de coincement tels que des rouleaux de commande.

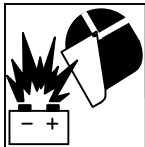

## LA SORTIE DE RECHARGE et L'EXPLOSION DE LA BATTERIE peuvent provoquer des blessures.

La recharge de batterie n'existe pas sur tous les modèles.

- Toujours porter une protection faciale, des gants en caoutchouc et vêtements de protection lors d'une intervention sur la batterie.
- Arrêter le moteur avant de débrancher ou de brancher des câbles de batterie, des câbles de chargeur de batterie (le cas échéant) ou de batterie d'entretien.
- Éviter de provoquer des étincelles avec les outils en travaillant sur la batterie.
- Ne pas utiliser l'appareil de soudage pour charger des batteries ou faire démarrer des véhicules à l'aide de câbles de démarrage, sauf si l'appareil dispose d'une fonctionnalité de charge de batterie destinée à cet usage.
- Observer la polarité correcte (+ et -) sur les batteries.
- Débrancher le câble négatif (-) en premier lieu. Le rebrancher en dernier lieu.
- Les sources d'étincelles, flammes nues, cigarettes et autres sources d'inflammation doivent être maintenues à l'écart des batteries. Ces dernières produisent des gaz explosifs en fonctionnement normal et en cours de charge.
- Suivre les instructions du fabricant de la batterie lors d'opérations sur une batterie ou à proximité de celle-ci. Voir le manuel de service de batterie (indiqué dans Normes de sécurité) pour plus d'informations.
- Les opérations de charge de batterie ne doivent être effectuées que par des personnes qualifiées.
- Pour enlever la batterie d'un véhicule pour la recharge, débrancher tout d'abord le câble négatif (-) et le rebrancher en dernier lieu. Pour éviter un arc, s'assurer que tous les accessoires sont débranchés.
- Ne charger que des batteries plomb-acide. Ne pas utiliser le chargeur de batterie pour alimenter un autre circuit électrique basse tension ou pour charger des batteries sèches.
- Ne pas charger une batterie gelée.
- Ne pas utiliser de câbles de charge endommagés.
- Ne pas charger des batteries dans un espace fermé ou en l'absence d'une ventilation.
- Ne pas charger une batterie dont les bornes sont desserrées ou présentant une détérioration comme par exemple un boîtier ou un couvercle fissuré.
- Avant de charger une batterie, sélectionner la tension de charge correspondant à la tension de la batterie.
- Régler les commandes de charge de batterie sur la position d'arrêt avant de brancher la batterie. Veiller à ce que les pinces de charge ne se touchent pas.
- Ranger les câbles de charge à distance du capot, des portes et des pièces mobiles du véhicule.



## LES LIQUIDES PRESSURISÉS peuvent blesser ou tuer.

- Les composants du système d'alimentation peuvent contenir du carburant sous pression élevée.
- Avant d'intervenir sur le système d'alimentation de carburant, arrêter le moteur pour dépressuriser le système.
- En cas d'injection de tout liquide sous la peau ou dans le corps, solliciter une aide médicale sur le champ.



## LES FILS DE SOUDAGE peuvent provoquer des blessures.

- Ne pas appuyer sur la gâchette avant d'en avoir reçu l'instruction.
- Ne pas diriger le pistolet vers soi, d'autres personnes ou toute pièce mécanique en engageant le fil de soudage.

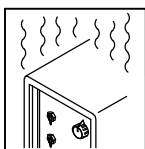

## L'EMPLOI EXCESSIF peut SURCHAUFFER L'ÉQUIPEMENT.

- Laisser l'équipement refroidir ; respecter le facteur de marche nominal.

- Réduire le courant ou le facteur de marche avant de poursuivre le soudage.
- Ne pas obstruer les passages d'air du poste.

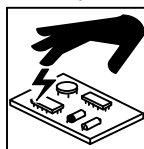

## LES CHARGES ÉLECTROSTATIQUES peuvent endommager les circuits imprimés.

- Établir la connexion avec la barrette de terre avant de manipuler des cartes ou des pièces.
- Utiliser des pochettes et des boîtes antistatiques pour stocker, déplacer ou expédier des cartes de circuits imprimés.



## UNE REMORQUE QUI BASCULE peut provoquer des blessures.

- Utiliser les supports de la remorque ou des blocs pour soutenir le poids.
- Installer convenablement le poste sur la remorque comme indiqué dans le manuel s'y rapportant.

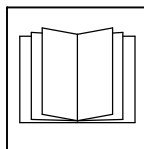

## LIRE LES INSTRUCTIONS.

- Lire et appliquer les instructions sur les étiquettes et le Mode d'emploi avant l'installation, l'utilisation ou l'entretien de l'appareil. Lire les informations de sécurité au début du manuel et dans chaque section.
- N'utiliser que les pièces de rechange recommandées par le constructeur.
- Effectuer l'installation, l'entretien et toute intervention selon les manuels d'utilisateurs, les normes nationales, provinciales et de l'industrie, ainsi que les codes municipaux.

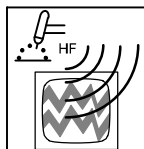

## LE RAYONNEMENT HAUTE FRÉQUENCE (H.F.) risque de provoquer des interférences.

- Le rayonnement haute fréquence (H.F.) peut provoquer des interférences avec les équipements de radio-navigation et de communication, les services de sécurité et les ordinateurs.
- Demander seulement à des personnes qualifiées familiarisées avec des équipements électroniques de faire fonctionner l'installation.
- L'utilisateur est tenu de faire corriger rapidement par un électricien qualifié les interférences résultant de l'installation.
- Si le FCC signale des interférences, arrêter immédiatement l'appareil.
- Effectuer régulièrement le contrôle et l'entretien de l'installation.
- Maintenir soigneusement fermés les portes et les panneaux des sources de haute fréquence, maintenir les éclateurs à une distance correcte et utiliser une terre et un blindage pour réduire les interférences éventuelles.

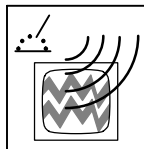

## LE SOUDAGE À L'ARC risque de provoquer des interférences.

- L'énergie électromagnétique risque de provoquer des interférences pour l'équipement électronique sensible tel que les ordinateurs et l'équipement commandé par ordinateur tel que les robots.
- Veiller à ce que tout l'équipement de la zone de soudage soit compatible électromagnétiquement.
- Pour réduire la possibilité d'interférence, maintenir les câbles de soudage aussi courts que possible, les grouper, et les poser aussi bas que possible (ex. par terre).
- Veiller à souder à une distance de 100 mètres de tout équipement électronique sensible.
- Veiller à ce que ce poste de soudage soit posé et mis à la terre conformément à ce mode d'emploi.
- En cas d'interférences après avoir pris les mesures précédentes, il incombe à l'utilisateur de prendre des mesures supplémentaires telles que le déplacement du poste, l'utilisation de câbles blindés, l'utilisation de filtres de ligne ou la pose de protecteurs dans la zone de travail.

## 2-6. Proposition californienne 65 Avertissements

**⚠** **AVERTISSEMENT :** ce produit peut vous exposer à des produits chimiques tels que le plomb, reconnus par l'État de Californie comme cancérigènes et sources de malformations ou d'autres troubles de la reproduction.

Pour plus d'informations, consulter [www.P65Warnings.ca.gov](http://www.P65Warnings.ca.gov).

Pour les moteurs diesel :

**⚠** **AVERTISSEMENT :** les gaz d'échappement de moteurs diesel vous exposent à des produits chimiques, reconnus par l'État de Californie comme cancérigènes et sources de malformations ou d'autres troubles de la reproduction.

- Toujours démarrer et faire tourner le moteur dans une zone bien aérée.
- Si la zone est fermée, diriger l'échappement vers l'extérieur.
- Ne pas modifier ni altérer le système d'échappement.
- Ne pas faire tourner le moteur au ralenti, sauf si nécessaire.

Pour plus d'informations, consulter [www.P65Warnings.ca.gov/diesel](http://www.P65Warnings.ca.gov/diesel).

## 2-7. Principales normes de sécurité

*Safety in Welding, Cutting, and Allied Processes*, ANSI Standard Z49.1, is available as a free download from the American Welding Society at <http://www.aws.org> or purchased from Global Engineering Documents (phone: 1-877-413-5184, website: [www.global.ihs.com](http://www.global.ihs.com)).

*Safe Practices for the Preparation of Containers and Piping for Welding and Cutting*, American Welding Society Standard AWS F4.1, from Global Engineering Documents (phone: 1-877-413-5184, website: [www.global.ihs.com](http://www.global.ihs.com)).

*Safe Practices for Welding and Cutting Containers that have Held Combustibles*, American Welding Society Standard AWS A6.0, from Global Engineering Documents (phone: 1-877-413-5184, website: [www.global.ihs.com](http://www.global.ihs.com)).

*National Electrical Code*, NFPA Standard 70, from National Fire Protection Association, Quincy, MA 02169 (phone: 1-800-344-3555, website: [www.nfpa.org](http://www.nfpa.org) and [www.sparky.org](http://www.sparky.org)).

*Safe Handling of Compressed Gases in Cylinders*, CGA Pamphlet P-1, from Compressed Gas Association, 14501 George Carter Way, Suite 103, Chantilly, VA 20151 (phone: 703-788-2700, website: [www.cganet.com](http://www.cganet.com)).

*Safety in Welding, Cutting, and Allied Processes*, CSA Standard W117.2, from Canadian Standards Association, Standards Sales, 5060 Spectrum Way, Suite 100, Mississauga, Ontario, Canada L4W 5NS (phone: 800-463-6727, website: [www.csagroup.org](http://www.csagroup.org)).

*Battery Chargers*, CSA Standard C22.2 NO 107.2-01, from Canadian Standards Association, Standards Sales, 5060 Spectrum Way, Suite 100, Mississauga, Ontario, Canada L4W 5NS (phone: 800-463-6727, website: [www.csagroup.org](http://www.csagroup.org)).

*Safe Practice For Occupational And Educational Eye And Face Protection*, ANSI Standard Z87.1, from American National Standards Institute, 25 West 43rd Street, New York, NY 10036 (phone: 212-642-4900, website: [www.ansi.org](http://www.ansi.org)).

*Standard for Fire Prevention During Welding, Cutting, and Other Hot Work*, NFPA Standard 51B, from National Fire Protection Association, Quincy, MA 02169 (phone: 1-800-344-3555, website: [www.nfpa.org](http://www.nfpa.org).)  
OSHA, Occupational Safety and Health Standards for General Industry, Title 29, Code of Federal Regulations (CFR), Part 1910, Subpart Q, and Part 1926, Subpart J, auprès du U.S. Government Printing Office, Superintendent of Documents, P.O. Box 371954, Pittsburgh, PA 15250-7954 (téléphone : 1-866-512-1800) (il y a 10 bureaux régionaux—le téléphone de la région 5, Chicago, est 3123532220, site Internet : [www.osha.gov](http://www.osha.gov)).

*Portable Generators Safety Alert*, U.S. Consumer Product Safety Commission (CPSC), 4330 East West Highway, Bethesda, MD 20814 (phone: 301-504-7923, website: [www.cpsc.gov](http://www.cpsc.gov)).

*Applications Manual for the Revised NIOSH Lifting Equation*, The National Institute for Occupational Safety and Health (NIOSH), 1600 Clifton Rd, Atlanta, GA 30329-4027 (phone: 1-800-232-4636, website: [www.cdc.gov/NIOSH](http://www.cdc.gov/NIOSH)).

Pour les normes réglémentant les systèmes hydrauliques, communiquez avec National Fluid Power Association, 6737 West Washington St., Suite 2350, Milwaukee, WI 53214 (téléphone : (414) 778-3344, site web : [www.nfpa.com](http://www.nfpa.com)).

*Manuel de service de batterie*, Battery Council International, 330 North Wabash Ave., Suite 2000, Chicago IL 60611 (téléphone : 1-312-245-1074, site Web : [www.batterycouncil.org](http://www.batterycouncil.org)).

## 2-8. Informations relatives aux CEM

Le courant électrique qui traverse tout conducteur génère des champs électromagnétiques (CEM) à certains endroits. Le courant issu d'un soudage à l'arc (et de procédés connexes, y compris le soudage par points, le gougeage, le découpage plasma et les opérations de chauffage par induction) crée un champ électromagnétique (CEM) autour du circuit de soudage. Les champs électromagnétiques produits peuvent causer interférence à certains implants médicaux, p. ex. les stimulateurs cardiaques. Des mesures de protection pour les porteurs d'implants médicaux doivent être prises: par exemple, des restrictions d'accès pour les passants ou une évaluation individuelle des risques pour les soudeurs. Tous les soudeurs doivent appliquer les procédures suivantes pour minimiser l'exposition aux CEM provenant du circuit de soudage:

1. Rassembler les câbles en les torsadant ou en les attachant avec du ruban adhésif ou avec une housse.
2. Ne pas se tenir au milieu des câbles de soudage. Disposer les câbles d'un côté et à distance de l'opérateur.



3. Ne pas courber et ne pas entourer les câbles autour de votre corps.
4. Maintenir la tête et le torse aussi loin que possible du matériel du circuit de soudage.
5. Connecter la pince sur la pièce aussi près que possible de la soudure.
6. Ne pas travailler à proximité d'une source de soudage, ni s'asseoir ou se pencher dessus.
7. Ne pas souder tout en portant la source de soudage ou le dévidoir.

### En ce qui concerne les implants médicaux :



Les porteurs d'implants doivent d'abord consulter leur médecin avant de s'approcher des opérations de soudage à l'arc, de soudage par points, de gougeage, du coupage plasma ou de chauffage par induction. Si le médecin approuve, il est recommandé de suivre les procédures précédentes.



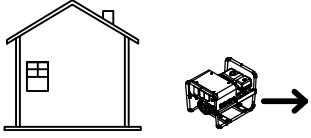



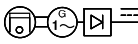



## SECTION 3 – DEFINITIONS







### 3-1. Additional Safety Symbol Definitions

	Warning! Watch Out! There are possible hazards as shown by the symbols. <div style="text-align: right; font-size: small;">Safe1 2012-05</div>
	Never use generator inside a home or garage, even if doors and windows are open. <div style="text-align: right; font-size: small;">Safe87 2012-07</div>
	Only use generator outside and far away from windows, doors, and vents. <div style="text-align: right; font-size: small;">Safe88 2012-07</div>

### 3-2. Miscellaneous Symbol Definitions

A	Amperage
V	Voltage
U <sub>0</sub>	Rated No-Load Voltage (OCV)
U <sub>2</sub>	Conventional Load Voltage
I <sub>2</sub>	Rated Welding Current
X	Duty Cycle
	Engine-Driven Generator with Rectifier
-	Negative
+	Positive
	Direct Current (DC)
~	Alternating Current (AC)

	Protective Earth (Ground)
	Circuit Breaker Supplementary Protector
	Single Phase Alternator
	Read Operator's Manual
	Shielded Metal Arc Welding (SMAW)
	Fuel
	Fuel Shutoff
	Engine Oil
	Engine Choke
	Battery (Engine)
	Air Filter

	Engine
	Engine
	Engine Start Engine RPM
	Engine Stop
	Idle (Slow)
	Run (Fast)
	Temperature
n	Rated Load Speed
Hz	Hertz
n <sub>0</sub>	Rated No-Load Speed
1~	Single Phase

## SECTION 4 – SPECIFICATIONS

### 4-1. Serial Number And Rating Label Location

The serial number and the rating information for this product is located on the stator. Use rating label to determine input power requirements and/or rated output. For future reference, write serial number in space provided on back cover of this manual.

### 4-2. Weld, Power, And Engine Specifications

☞ This equipment will deliver rated output at an ambient air temperature up to 104 °F (40 °C).

Welding Mode	Weld Output Range	Rated Welding Output	Maximum OCV	Generator Power Rating	Fuel Capacity	Engine
CC/DC	40 – 145 A	130 A, 25 V 30% Duty Cycle	70	Single-Phase, 4.5 kVA/kW (Surge) 4 kVA/kW (Continuous) 34/17 A, 120/240 V AC, 60 Hz	6.25 gal (23.66 L) Tank	Briggs & Stratton Air-Cooled, One- Cylinder, Four-Cycle, Series 1450, Gasoline Engine

### 4-3. Dimensions, Weights, And Operating Angles

Dimensions	
Height	24.75 in. (629 mm)
Width	20-3/32 in. (510 mm)
Depth	31.25 in. (794 mm)
A	31.25 in. (794 mm)
B	7-39/64 in. (193 mm)
C	15-3/32 in. (383 mm)
D	20-3/32 in. (510 mm)
E	1-11/32 in. (34 mm)
F	16-27/32 in. (428 mm)
G	13/32 in. (10 mm) Dia.
Weight	
	207 lb (94 kg)
Optional Lifting Eye Weight Rating	
	430 lb (195 kg)

**Engine End**

Do not exceed tilt angles or engine could be damaged or unit could tip.

Do not move or operate unit where it could tip.

15° 15° 15° 15°

268 245

### 4-4. Duty Cycle

Duty cycle is the percentage of 10 minutes that unit can weld at rated load without overheating.

1 30% Duty Cycle

This unit is rated at 30% duty cycle (3 minutes welding, 7 minutes resting) at 130 amperes.

**NOTICE** – Exceeding duty cycle can damage unit and void warranty.

% Duty Cycle	Weld Amperes
0	140
10	140
20	140
25	140
30	130
40	115
50	100
60	90
70	80
80	75
90	70
100	65

250 195

## 4-5. Environmental Specifications

### A. Temperature Specifications

Operating Temperature Range*	Storage/Transportation Temperature Range
14 to 104°F (-10 to 40°C)	-4 to 131°F (-20 to 55°C)
*Output is derated at temperatures above 104°F (40°C).	Temp_2016-07

## 4-6. Fuel Consumption

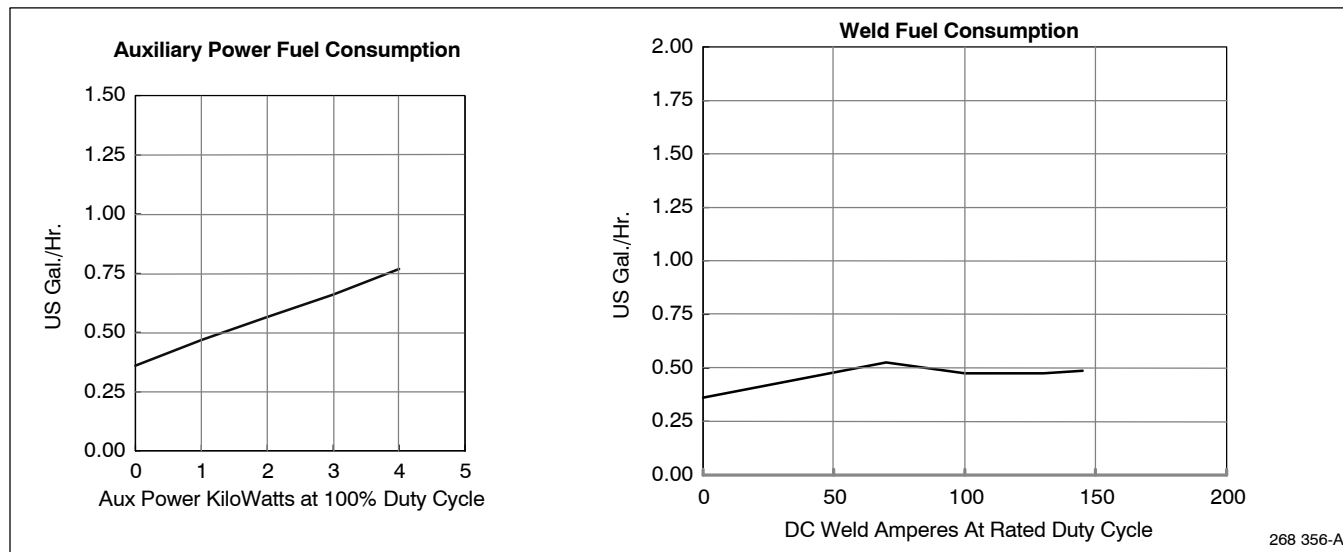

## 4-7. Generator Power Curve

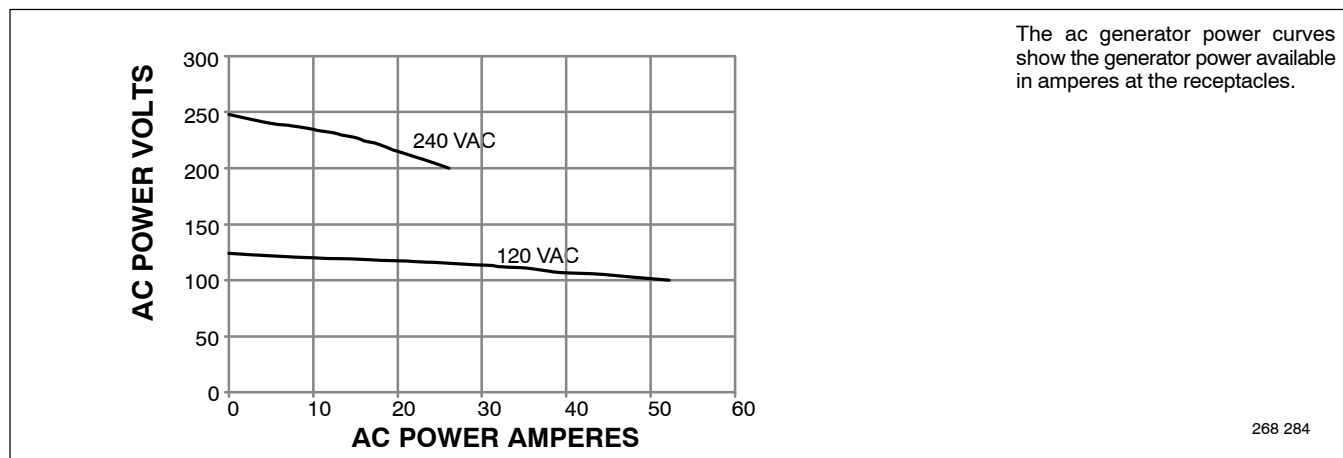

## 4-8. Volt-Ampere Curves

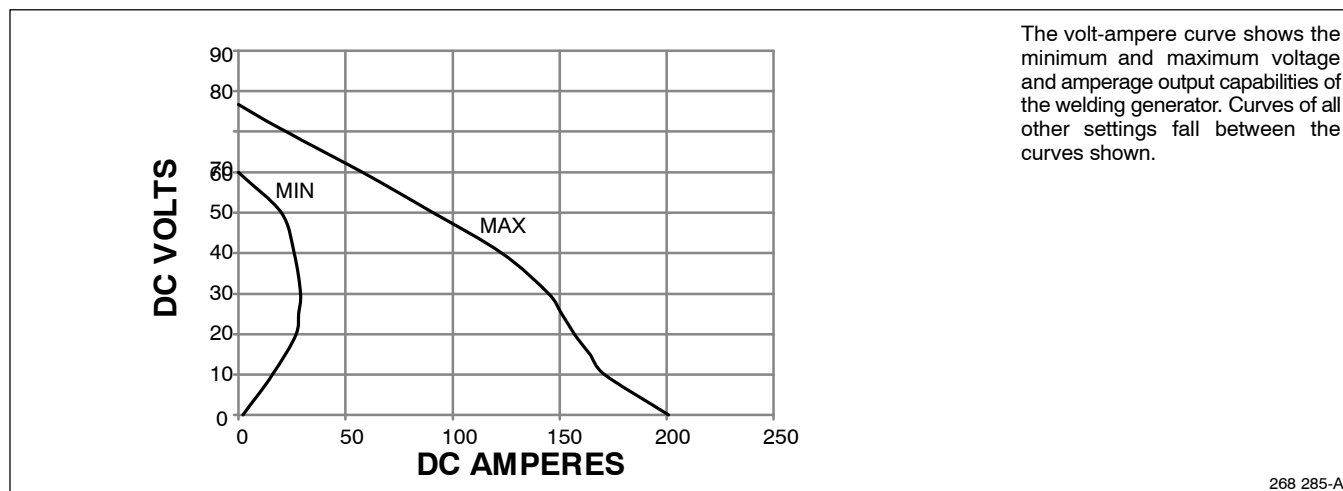

## SECTION 5 – INSTALLATION

### 5-1. Installing Welder/Generator



#### Movement

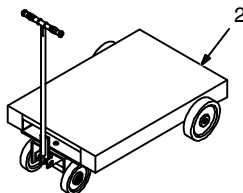
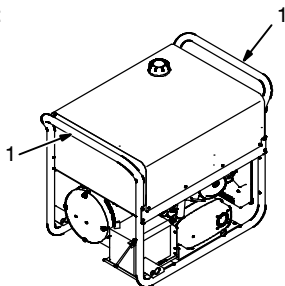

- 1 Lifting Handles  
Use handles to lift unit.
- 2 Hand Cart  
Use cart or similar device to move unit.

- ⚠ Do not install unit where air flow is restricted or engine may overheat.
- ⚠ Do not move or operate unit where it could tip.
- ⚠ Always securely fasten welder/generator onto transport vehicle or trailer and comply with all DOT and other applicable codes

#### Location And Airflow

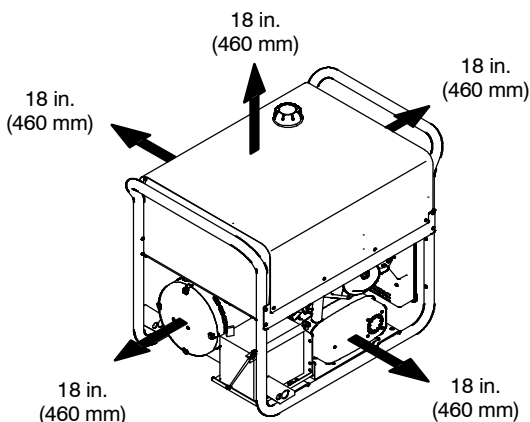
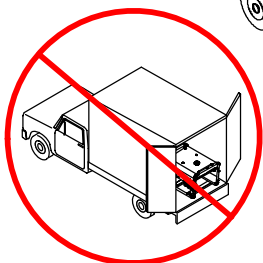
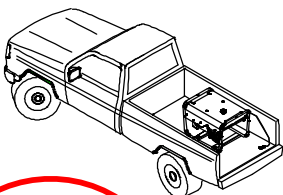

☞ Go to [MillerWelds.com](http://MillerWelds.com) for more information on truck installations.

Rotinstall5-2017-04

### 5-2. Grounding Generator To Truck Or Trailer Frame

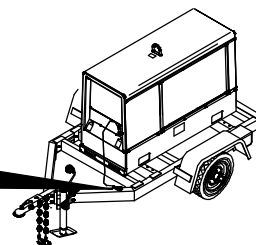
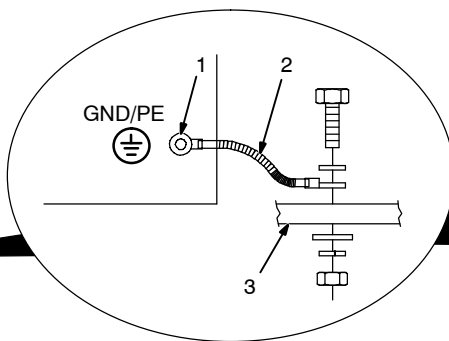
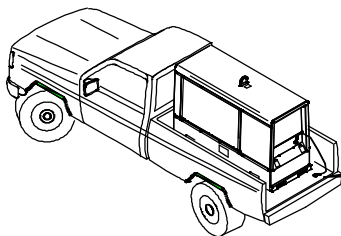

rot\_grnd2 2014-11 - 800 652-D

- ⚠ Always ground generator frame to vehicle frame to prevent electric shock and static electricity hazards.
- ⚠ Also see AWS Safety & Health Fact Sheet No. 29, Grounding of Portable And Vehicle Mounted Welding Generators.
- ⚠ Bed liners, shipping skids, and some running gear insulate the welding generator from the vehicle

frame. Always connect a ground wire from the generator equipment grounding terminal to bare metal on the vehicle frame as shown.



- ⚠ Use GFCI protection when operating auxiliary equipment. If unit does not have GFCI receptacles, use GFCI-protected extension cord. Do not use GFCI receptacles to power life support equipment.



- 1 Equipment Grounding Terminal (On Front Panel)
- 2 Grounding Cable (Not Supplied)
- 3 Metal Vehicle Frame

Connect cable from equipment ground terminal to metal vehicle frame. Use #8 AWG or larger insulated copper wire.

☞ Electrically bond generator frame to vehicle frame by metal-to-metal contact.

### 5-3. Engine Prestart Checks





	<p><b>ENGINE FUEL can cause fire or explosion.</b></p> <ul style="list-style-type: none"> <li>• Close fuel valve when unit is not in use or during transport.</li> </ul>	 
	<p><b>LE CARBURANT DU MOTEUR peut causer un incendie ou une explosion.</b></p> <ul style="list-style-type: none"> <li>• Fermer la soupape de carburant lorsque l'unité n'est pas utilisée ou pendant le transport.</li> </ul>	
	<p><b>EI COMBUSTIBLE DEL MOTOR puede causar incendios o explosiones.</b></p> <ul style="list-style-type: none"> <li>• Cierre la válvula de combustible cuando la unidad no está en uso o durante el transporte.</li> </ul>	

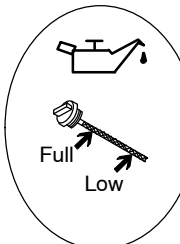

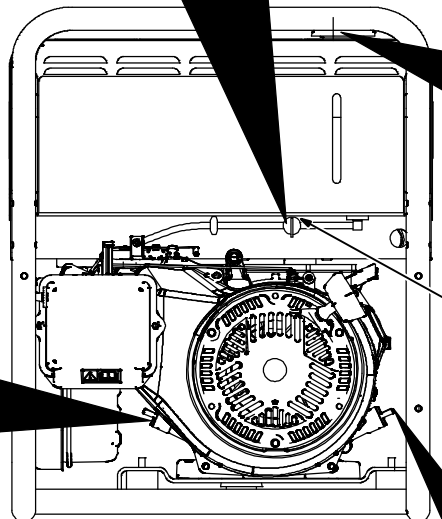

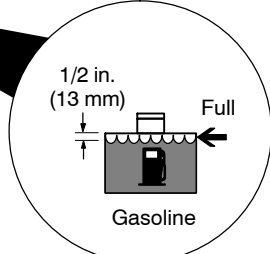

Gasoline

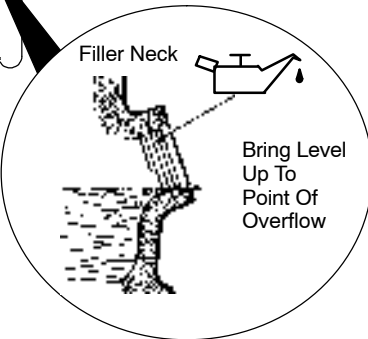

Bring Level Up To Point Of Overflow

**Fuel**

Add fresh fuel before starting engine the first time. Fill fuel tank up to 1/2 in. (13 mm) from top to allow room for expansion. Check fuel level on a cold engine before use each day.

**Oil**



After fueling, check oil with unit on level surface. If oil reservoir is not full, add oil until oil nearly overflows at oil fill.

*☞ This unit has a low oil level shutdown switch to prevent starting an engine that is low on oil. However, some conditions may cause engine damage before the engine shuts down. Check oil level often and do not use the low oil level shutdown system to monitor oil level.*

*☞ To improve cold weather starting, use correct grade oil for cold weather (see engine owner's manual).*

268 244

### 5-4. Weld Output Terminals

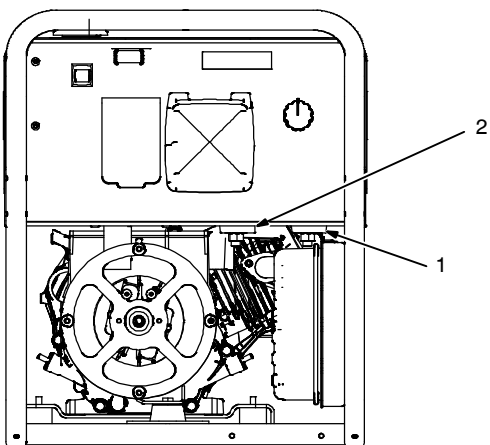

**Tools Needed:**

 3/4 in.

**⚠ Turn off power before connecting to weld output terminals.**

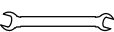
**⚠ Do not use worn, damaged, undersized, or repaired cables.**

- 1 Negative (-) Weld Output Terminal
- 2 Positive (+) Weld Output Terminal

For Direct Current Electrode Positive (DCEP), connect electrode holder to Positive (+) terminal and work cable to Negative (-) terminal.

For Direct Current Electrode Negative (DCEN), reverse cable connections.

268 244

## 5-5. Connecting Weld Output Cables

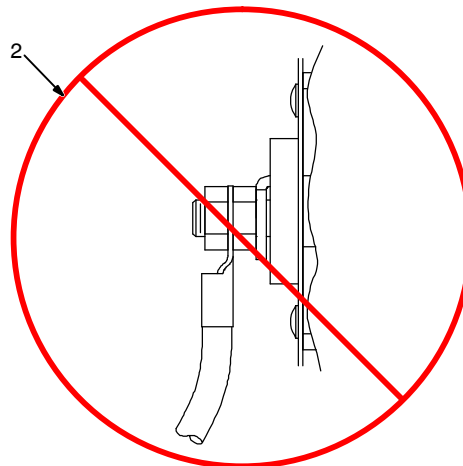
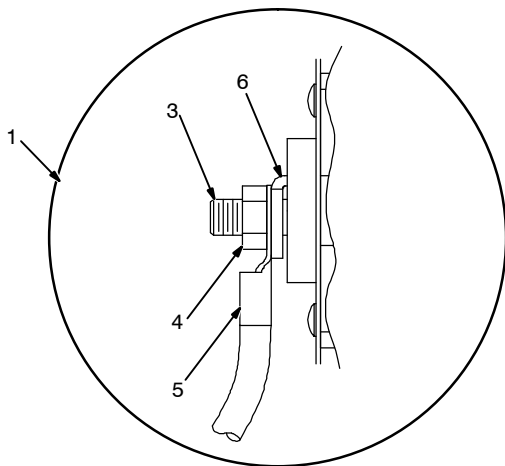

Tools Needed:

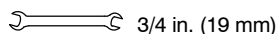

803 778-B

**⚠ Turn off power before connecting to weld output terminals.**

**⚠ Failure to properly connect weld cables may cause excessive heat and start a fire, or damage your machine.**

**🚫 Do not place anything between weld**

*cable terminal and copper bar. Make sure that the surfaces of the weld cable terminal and copper bar are clean.*

- 1 Correct Weld Cable Connection
- 2 Incorrect weld Cable Connection
- 3 Weld Output Terminal
- 4 Supplied Weld Output Terminal Nut

- 5 Weld Cable Terminal
- 6 Copper Bar

Remove supplied nut from weld output terminal. Slide weld cable terminal onto weld output terminal and secure with nut so that weld cable terminal is tight against copper bar.

## 5-6. Selecting Cable Sizes\*

**NOTICE** – The Total Cable Length in Weld Circuit (see table below) is the combined length of both weld cables. For example, if the power source is 100 ft (30 m) from the workpiece, the total cable length in the weld circuit is 200 ft (2 cables x 100 ft). Use the 200 ft (60 m) column to determine cable size.

Welding Amperes	Weld Cable Size** and Total Cable (Copper) Length in Weld Circuit Not Exceeding***							
	100 ft (30 m) or Less		150 ft (45 m)	200 ft (60 m)	250 ft (70 m)	300 ft (90 m)	350 ft (105 m)	400 ft (120 m)
	10 – 60% Duty Cycle AWG (mm <sup>2</sup> )	60 – 100% Duty Cycle AWG (mm <sup>2</sup> )	10 – 100% Duty Cycle AWG (mm <sup>2</sup> )					
100	4 (20)	4 (20)	4 (20)	3 (30)	2 (35)	1 (50)	1/0 (60)	1/0 (60)
150	3 (30)	3 (30)	2 (35)	1 (50)	1/0 (60)	2/0 (70)	3/0 (95)	3/0 (95)
200	3 (30)	2 (35)	1 (50)	1/0 (60)	2/0 (70)	3/0 (95)	4/0 (120)	4/0 (120)
250	2 (35)	1 (50)	1/0 (60)	2/0 (70)	3/0 (95)	4/0 (120)	2x2/0 (2x70)	2x2/0 (2x70)
300	1 (50)	1/0 (60)	2/0 (70)	3/0 (95)	4/0 (120)	2x2/0 (2x70)	2x3/0 (2x95)	2x3/0 (2x95)

\* This chart is a general guideline and may not suit all applications. If cable overheats, use next size larger cable.

\*\*Weld cable size (AWG) is based on either a 4 volts or less drop or a current density of at least 300 circular mils per ampere. ( ) = mm<sup>2</sup> for metric use

\*\*\*For distances longer than those shown in this guide, see AWS Fact Sheet No. 39, Welding Cables, available from the American Welding Society at <http://www.aws.org>.

Ref. S-0007-M 2017-08

# SECTION 6 – OPERATING THE WELDING GENERATOR

## 6-1. Controls

**1** Engine Switch

Use switch to control ignition circuit, and to stop engine.

**2** Choke Control

Use control to change engine air/fuel mix. Move control to left (Choke) if starting a cold engine. Move control to right (Run) if starting a warm engine.

**3** Starter Handle

**To Start:**

- Open fuel valve (see Section 5-3).
- Place engine switch in RUN position.
- Set Choke control.

- Pull starter handle until engine starts.
- Move Choke control to the right (Run) as the engine warms.

☞ *This unit has a low oil level shutdown to prevent starting an engine that is too low on oil. The low oil level shutdown may not stop a running engine. Check oil level if the engine does not start, or has stopped and cannot be restarted.*

**To Stop:** Place engine switch in OFF position.

☞ *Always close fuel valve after stopping unit. Moving unit with fuel valve open may cause carburetor flooding and make starting difficult.*

**4** Amperage Control

Use control to select weld amperage. Control may be adjusted while welding. Set Amperage control at MAX for full generator power output at AC receptacles.

**To Set Amperage control:** Use electrode chart (see Section 6-2) to determine correct size electrode. Select electrode type and set Amperage control to corresponding amperage range on nameplate. Adjust control within selected range to obtain desired weld performance.

**EXAMPLE:**  
 Electrode Type: 6013  
 Electrode Diameter: 1/8  
 Amperage control Setting: 80 – 120 A

Electrode	Electrode Type	Electrode Size	60	80	100	120	150
6010	6010	1/8					
6011	6011	1/8					
6012	6012	1/8					
6013	6013	1/8					
6014	6014	1/8					
6015	6015	1/8					
6016	6016	1/8					
6017	6017	1/8					
6018	6018	1/8					
6019	6019	1/8					
6020	6020	1/8					
6021	6021	1/8					
6022	6022	1/8					
6023	6023	1/8					
6024	6024	1/8					
6025	6025	1/8					
6026	6026	1/8					
6027	6027	1/8					
6028	6028	1/8					
6029	6029	1/8					
6030	6030	1/8					
6031	6031	1/8					
6032	6032	1/8					
6033	6033	1/8					
6034	6034	1/8					
6035	6035	1/8					
6036	6036	1/8					
6037	6037	1/8					
6038	6038	1/8					
6039	6039	1/8					
6040	6040	1/8					
6041	6041	1/8					
6042	6042	1/8					
6043	6043	1/8					
6044	6044	1/8					
6045	6045	1/8					
6046	6046	1/8					
6047	6047	1/8					
6048	6048	1/8					
6049	6049	1/8					
6050	6050	1/8					
6051	6051	1/8					
6052	6052	1/8					
6053	6053	1/8					
6054	6054	1/8					
6055	6055	1/8					
6056	6056	1/8					
6057	6057	1/8					
6058	6058	1/8					
6059	6059	1/8					
6060	6060	1/8					
6061	6061	1/8					
6062	6062	1/8					
6063	6063	1/8					
6064	6064	1/8					
6065	6065	1/8					
6066	6066	1/8					
6067	6067	1/8					
6068	6068	1/8					
6069	6069	1/8					
6070	6070	1/8					
6071	6071	1/8					
6072	6072	1/8					
6073	6073	1/8					
6074	6074	1/8					
6075	6075	1/8					
6076	6076	1/8					
6077	6077	1/8					
6078	6078	1/8					
6079	6079	1/8					
6080	6080	1/8					
6081	6081	1/8					
6082	6082	1/8					
6083	6083	1/8					
6084	6084	1/8					
6085	6085	1/8					
6086	6086	1/8					
6087	6087	1/8					
6088	6088	1/8					
6089	6089	1/8					
6090	6090	1/8					
6091	6091	1/8					
6092	6092	1/8					
6093	6093	1/8					
6094	6094	1/8					
6095	6095	1/8					
6096	6096	1/8					
6097	6097	1/8					
6098	6098	1/8					
6099	6099	1/8					
6100	6100	1/8					

268 244 / 268 258 / 282770-A

## 6-2. Amperage Selection Table For Stick (SMAW) Electrodes

ELECTRODE	DIAMETER	AMPS 50	75	100	125
6010 & 6011	3/32				
	1/8				
6013	5/32				
	3/32				
	1/8				
7018	3/32				
	1/8				

Use table to select correct amperage for the electrode being used.

Values listed are suggested settings. Actual settings may vary depending on personal preference and/or specific application.

Suggested electrode for beginners is E6013.

265 288-A

## 6-3. Cold Weather Operation

When temperatures are below 40°F (4°C) and humidity is high, the engine may experience icing of the carburetor and/or the crankcase breather system, causing operating problems such as stalling. Briggs & Stratton (1-800-444-7774) offers a heat shield (Briggs & Stratton Part No. 795886) for cold weather operation. The user can install this kit for cold weather operation.

# SECTION 7 – OPERATING AUXILIARY EQUIPMENT

## 7-1. Generator Power Panel Receptacles

☞ The welding generator provides power while welding with the Amperage control in any position. However, under these conditions equipment connected to the welding generator may be subject to larger than normal voltage fluctuations. It is recommended that only lamps be powered under these conditions.

282770-A

- ⚠ Use GFCI protection when operating auxiliary equipment. If unit does not have GFCI receptacles, use GFCI-protected extension cord. Do not use GFCI receptacle to power life support equipment.
- ⚠ Unplug power cord before attempting to service accessories or tools.

☞ Generator power decreases as weld current increases. Set Weld Output control to maximum for full generator power output at AC receptacles.

- 1 120 V 20 A AC GFCI Receptacles GFCI-2 and GFCI-3

GFCI-2 and GFCI-3 supply 60 Hz single-phase power at weld/power speed. Maximum output from GFCI-2 or GFCI-3 is 2.4 kVA/kW.

- ⚠ Test GFCI monthly. See Section 7-2 for information, resetting and testing of GFCI receptacles.

**NOTICE** – Do not parallel the two 120 V duplex receptacles.

- 2 240 V 50 A AC Receptacle RC1

RC1 supplies 60 Hz single-phase power at weld/power speed. Maximum output is 4 kVA/kW.

- 3 Supplementary Protector CB1

CB1 protects the receptacles from overload. If CB1 opens, the receptacles do not work. Place switch in the on position to reset.

☞ Place switch in the On position to reset. If supplementary protector continues to open, contact Factory Authorized Service Agent.

Combined output of all receptacles limited to 4 kVA/kW rating of the generator (See Section 12 – Generator Power Guidelines).

EXAMPLE: If 15 A is drawn from the 120 volt duplex receptacle, only 9 A is available from the 240 V receptacle.

$$(120\text{ V} \times 15\text{ A}) + (240\text{ V} \times 9\text{ A}) = 4\text{ kVA/KW.}$$

## 7-2. GFCI Receptacle Information, Resetting, And Testing



☞ Alternate location for red and green indicator LEDs.

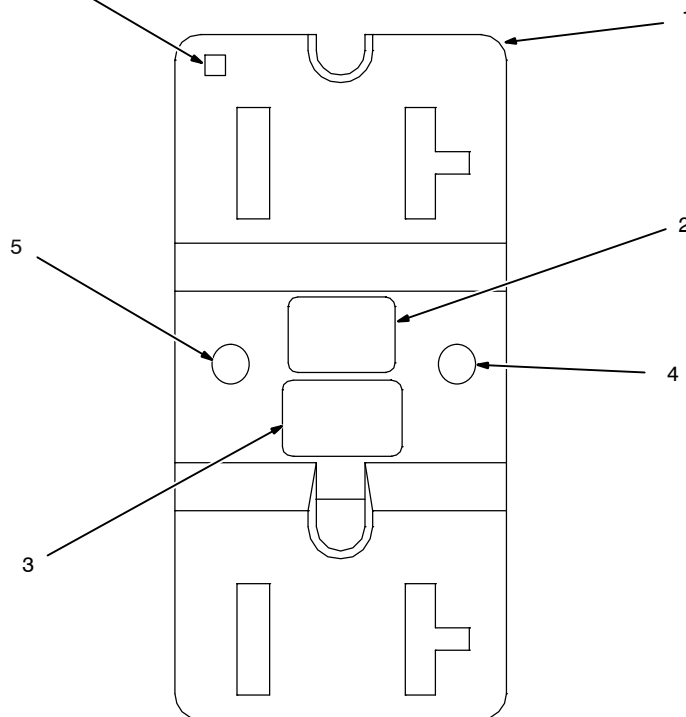

☞ Orientation of receptacle may be different in other applications.

RotGFCI1 2018-12

**⚠ Use GFCI protection when operating auxiliary equipment. If unit does not have GFCI receptacles, use GFCI-protected extension cord. Do not use GFCI receptacle to power life support equipment.**

**⚠ Unplug power cord before attempting to service accessories or tools.**

- 1 120 V 20 A AC GFCI Receptacle
- 2 GFCI Receptacle Test Button
- 3 GFCI Receptacle Reset Button
- 4 Red GFCI Indicator Light (LED)
- 5 Green GFCI Indicator Light (LED)

☞ Red and Green indicator lights may be combined in a single LED.

### GFCI Receptacles

GFCI receptacles protect the user from electric shock if a ground fault occurs in equipment connected to the receptacle. A ground fault occurs when electrical current takes the shortest path to ground (which could be through a person) rather than follow its intended safe path.

If a ground fault is detected, the GFCI Reset button pops out, and the circuit opens to disconnect power to the faulty equipment. A GFCI receptacle does not protect against circuit overloads, short circuits, or shocks not related to ground faults. Reset and test GFCI receptacle according to the following procedures.

A solid green LED indicates power to the GFCI. A solid red LED indicates that the GFCI has been tripped.

### Resetting/Testing GFCI Receptacle

- ⚠ Test GFCI monthly.**
- ⚠ If Red LED blinks, stop using GFCI receptacle and have a Factory Authorized Service Agent replace it.**
- ⚠ Extension cords with bad insulation or of extended length can allow enough leakage current to trip the GFCI circuit. Reset and test as follows.**

### Resetting GFCI Receptacles

If a GFCI fault occurs, stop engine and disconnect equipment from GFCI receptacle. Check for damaged or wet tools, cords, plugs, etc. connected to the receptacle. Start engine, place engine control switch in RUN position, and press GFCI Reset button. Reconnect equipment to GFCI receptacle. If GFCI Reset button pops out again, check the equipment and repair or replace if faulty.

### Testing GFCI Receptacles

Start engine and place engine control switch in Run position. Press the GFCI Test button. The GFCI Reset button should pop out.

Press the GFCI Reset button.







**Have a Factory Authorized Service Agent replace GFCI if any of the following occur:**

- GFCI does not trip when tested**
- Red LED blinks**
- GFCI does not reset.**

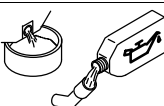
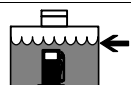

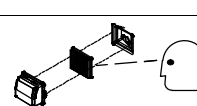
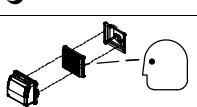
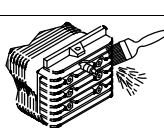
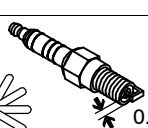



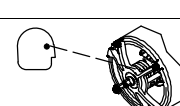
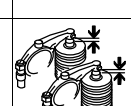



# SECTION 8 – MAINTENANCE

## 8-1. Routine Maintenance

							 <p>Recycle engine fluids.</p>	 <p><b>Stop engine before maintaining.</b></p>
<p><b>NOTICE</b> – This equipment meets US EPA Evaporative Standards. Be sure fuel system replacement parts meet EPA Evaporation Standards.</p>								<p>See <i>Engine Manual and Maintenance Label</i> for important start-up, service, and storage information. Service engine more often if used in severe conditions.</p>

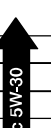
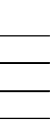
	✓ = Check ◇ = Change ● = Clean ☆ = Replace * To be done by Factory Authorized Service Agent				Reference
	 ◇ Oil After First 5 Hours	 ✓ Fuel Level Every 8 Hours	 ✓ Oil Level Every 8 Hours	 ● Oil, Fuel Spills Every 8 Hours	Engine Manual
Every 25 Hours	 ✓ Air Filter				Section 8-3
Every 50 Hours	 ● Weld Terminals				
Every 100 Hours	 ✓ ☆ Air Filter Element	 ● Cooling System	 ✓ Spark Plug Gap 0.030 in.	 ◇ Oil	Engine Manual, Section 8-3
Every 200 Hours	 ☆ Unreadable Labels				
Every 500 Hours	 ✓ ☆ Weld Cables	 ✓ Slip Rings* ✓ ☆ Brushes*	 ✓ Valve Clearance* 0.005 – 0.007 in. Intake & Exhaust		

## 8-2. Maintenance Label

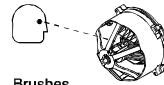
<b>BRIGGS &amp; STRATTON SERIES 1450 ENGINE</b>																					
<b>8 h</b>   <b>GASOLINE</b> 6.25 gal (23.7 L) Unleaded, 87 Octane min.	<b>25 h</b>  HOBART: 268296 Briggs & Stratton: 494279	<b>100 h</b>  1.15 qt (1.1 L) Use API Class SJ or higher.	<table border="1" style="width: 100%; border-collapse: collapse;"> <tr> <th style="width: 50%;">°F</th> <th style="width: 50%;">°C</th> </tr> <tr> <td style="text-align: center;">104</td> <td style="text-align: center;">40</td> </tr> <tr> <td style="text-align: center;">86</td> <td style="text-align: center;">30</td> </tr> <tr> <td style="text-align: center;">68</td> <td style="text-align: center;">20</td> </tr> <tr> <td style="text-align: center;">50</td> <td style="text-align: center;">10</td> </tr> <tr> <td style="text-align: center;">32</td> <td style="text-align: center;">0</td> </tr> <tr> <td style="text-align: center;">14</td> <td style="text-align: center;">-10</td> </tr> <tr> <td style="text-align: center;">-4</td> <td style="text-align: center;">-20</td> </tr> <tr> <td style="text-align: center;">-22</td> <td style="text-align: center;">-30</td> </tr> </table> <p style="text-align: center;">     </p>	°F	°C	104	40	86	30	68	20	50	10	32	0	14	-10	-4	-20	-22	-30
°F	°C																				
104	40																				
86	30																				
68	20																				
50	10																				
32	0																				
14	-10																				
-4	-20																				
-22	-30																				
<b>100 h</b>  HOBART: 251076 Briggs & Stratton: 394358S	 3650-3750 RPM	<b>1 y</b>  HOBART: 268297 Briggs & Stratton: 797235 Gap: 0.030 in. (.76 mm) Use only resistor spark plugs and wires.	<b>500 h</b>  Brushes MILLER: 493509																		

Ref. 282771-B

### 8-3. Servicing Air Filter

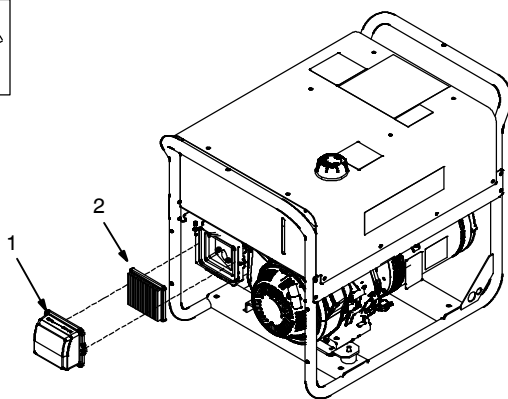

**⚠ Stop engine.**

**NOTICE** – Do not run engine without air filter or with dirty air filter.

1. Cover
2. Filter

Loosen fasteners that hold cover in place. Open cover and remove filter.

To loosen debris, gently tap filter on hard surface. Replace filter if excessively dirty.

Install filter, replace cover and tighten fasteners.

## SECTION 9 – TROUBLESHOOTING

### 9-1. Troubleshooting

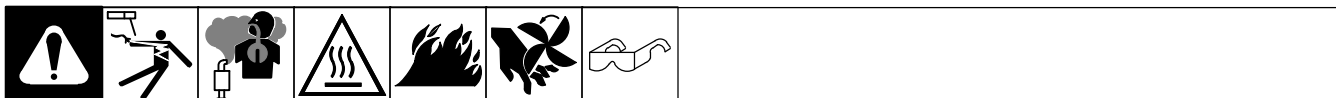

Welding Trouble	Remedy
No weld output; no generator power output at AC receptacles.	Be sure all equipment is disconnected from receptacles when starting unit.
	Have Factory Authorized Service Agent check brushes, slip rings, rotor, stator, integrated rectifier SR1, and capacitor C1.
No weld output; generator power output okay at AC receptacles.	Check Amperage control setting (see Section 6-1).
	Check weld connections.
	Have Factory Authorized Service Agent check stator, stabilizer DC-Z, and main rectifier SR2.
Low weld output.	Check Amperage control setting (see Section 6-1).
	Service air cleaner, fuel filter, and spark plug according to engine manual.
	Check weld cable size and length.
	Have Factory Authorized Service Agent check engine speed, and adjust if necessary.
	Have Factory Authorized Service Agent check brushes, slip rings, integrated rectifier SR1, capacitor C1, and main rectifier SR2.
High weld output.	Check Amperage control setting (see Section 6-1).
	Check engine speed.
Erratic weld output.	Check Amperage control setting (see Section 6-1).
	Tighten and clean connections to electrode and workpiece.
	Use dry, properly stored electrodes for Stick welding.
	Remove excessive coils from weld cables.
	Clean and tighten connections both inside and outside welding generator.
	Check governor linkage for smooth, non-binding operation.
	Have Factory Authorized Service Agent check engine speed, and adjust if necessary.

Generator Trouble	Remedy
No output at generator power AC receptacles; no weld output.	Be sure all equipment is disconnected from receptacles when starting unit.
	Have Factory Authorized Service Agent check brushes, slip rings, rotor, stator, integrated rectifier SR1, and capacitor C1.

Generator Trouble	Remedy
No output at generator power AC receptacles; weld output okay.	Reset supplementary protector (see Section 7-1).
	Check Amperage control setting (see Section 6-1). Set Amperage control at Max for generator power.
	Check receptacle wiring and connections.
	Have Factory Authorized Service Agent check engine speed, and adjust if necessary.
	Have Factory Authorized Service Agent check stator windings.
High output at generator power AC receptacles.	Have Factory Authorized Service Agent check engine speed, and adjust if necessary.
Low output at generator power AC receptacles.	Check Amperage control setting (see Section 6-1). Set Amperage control at Max for generator power.
	Have Factory Authorized Service Agent check engine speed, and adjust if necessary.
Erratic output at generator power AC receptacles.	Check fuel level.
	Check Amperage control setting. Set Amperage control at Max for generator power.
	Check receptacle wiring and connections.
	Check governor linkage for smooth, non-binding operation.
	Service air cleaner, fuel filter, and spark plug according to engine manual.
	Have Factory Authorized Service Agent check engine speed, and adjust if necessary.

Engine Trouble	Remedy
Engine will not start.	Place engine switch on front panel in RUN position.
	Check fuel level (see Section 5-3).
	Move choke control to correct position (see Section 6-1).
	Open fuel valve (see Section 5-3). Close fuel valve before moving unit or carburetor may flood and make starting difficult.
	Check oil level (see Section 5-3). Low oil level shutdown may stop if oil level is too low. Refill crankcase with proper viscosity oil for operating temperature.
	Have Factory Authorized Service Agent check low oil level shutdown switch.
Engine stopped during normal operation.	Check fuel level (see Section 5-3).
	Open fuel valve (see Section 5-3). Close fuel valve before moving unit or carburetor may flood and make starting difficult.
	Check oil level (see Section 5-3). Low oil level shutdown may stop if oil level is too low. Refill crankcase with proper viscosity oil for operating temperature.
Unstable or sluggish engine speeds.	Check governor linkage for smooth, non-binding operation.
	Service air cleaner, fuel filter, and spark plug according to engine manual.
	Tune-up engine according to engine manual.
	Have Factory Authorized Service Agent check engine speed, and adjust if necessary.

## SECTION 10 – PARTS LIST

### 10-1. Recommended Spare Parts

Part No.	Description	Quantity
268296	Air Filter	1
251076	Filter, Fuel In-line .250 Briggs 150um	1
268297	Spark Plug, Briggs & Stratton 1450	1

# SECTION 11 - ELECTRICAL DIAGRAMS

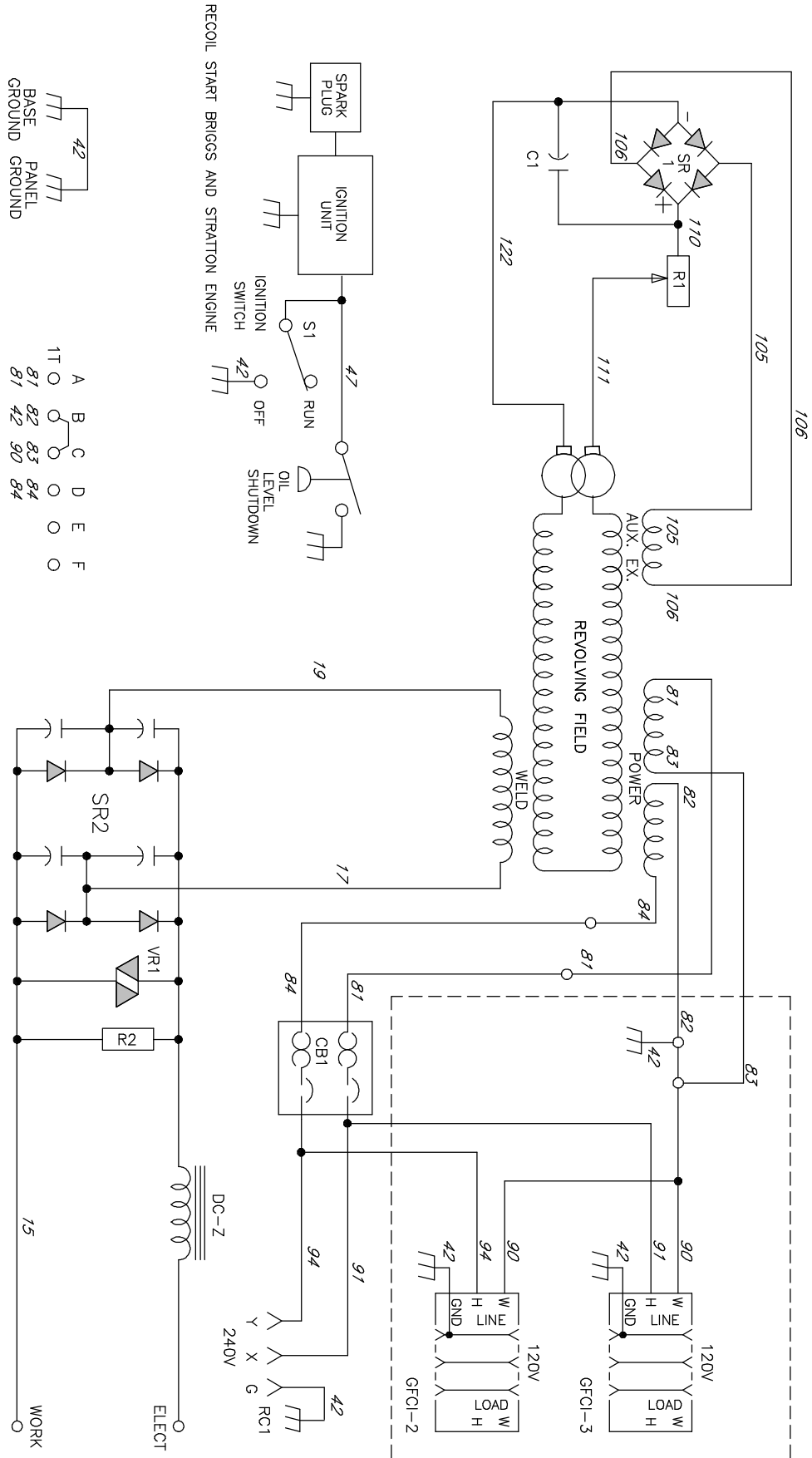



	<b>⚠ WARNING</b>
	<ul style="list-style-type: none"> <li>Do not touch live electrical parts.</li> <li>Disconnect input power or stop engine before servicing.</li> <li>Do not operate with covers removed.</li> <li>Have only qualified persons install, use, or service this unit.</li> </ul>
<b>ELECTRIC SHOCK HAZARD</b>	

Figure 11-1. Circuit Diagram For Welding Generator

# SECTION 12 – GENERATOR POWER GUIDELINES

*The views in this section are intended to be representative of all engine-driven welder/generators. Your unit may differ from those shown.*

## 12-1. Selecting Equipment



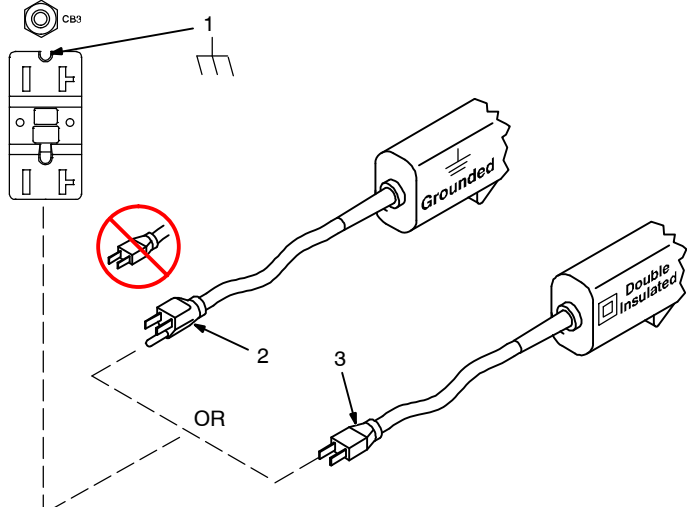

- 1 Generator Power Receptacles – Neutral Bonded To Frame
- 2 3-Prong Plug From Case Grounded Equipment
- 3 2-Prong Plug From Double Insulated Equipment

*Be sure equipment has double insulated symbol and/or wording on it.*

**Do not use 2-prong plug unless equipment is double insulated.**

gen\_pwr 2018-06 – ST-800 577

## 12-2. Grounding Generator To Truck Or Trailer Frame

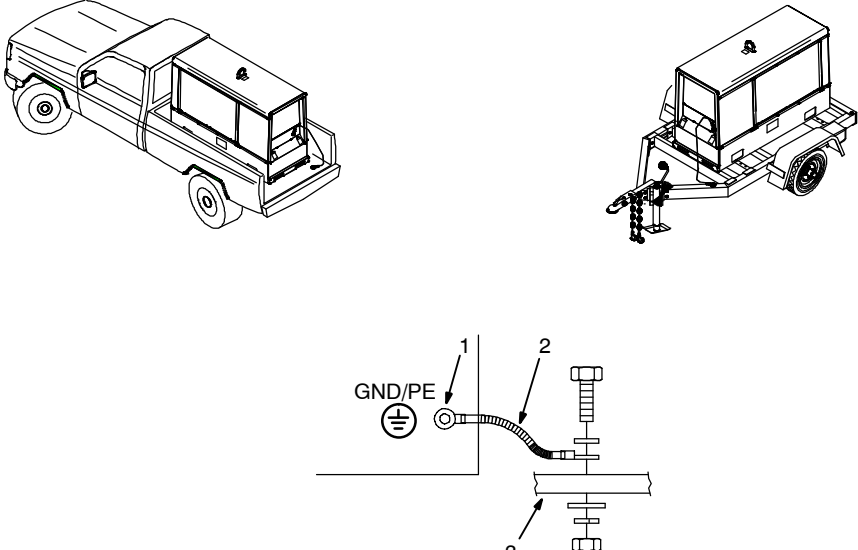

800 652-D

**Always ground generator frame to vehicle frame to prevent electric shock and static electricity hazards.**

**Also see AWS Safety & Health Fact Sheet No. 29, Grounding of Portable And Vehicle Mounted Welding Generators.**

- 1 Equipment Grounding Terminal (On Front Panel)
- 2 Grounding Cable (Not Supplied)

**3 Metal Vehicle Frame**

Connect cable from equipment ground terminal to metal vehicle frame. Use #8 AWG or larger insulated copper wire.



*Electrically bond generator frame to vehicle frame by metal-to-metal contact.*

**Bed liners, shipping skids, and some running gear insulate the welder/generator from the vehicle**

**frame. Always connect a ground wire from the generator equipment grounding terminal to bare metal on the vehicle frame as shown.**

**Use GFCI protection when operating auxiliary equipment. If unit does not have GFCI receptacles, use GFCI-protected extension cord. Do not use GFCI receptacles to power life support equipment.**

## 12-3. Grounding When Supplying Building Systems

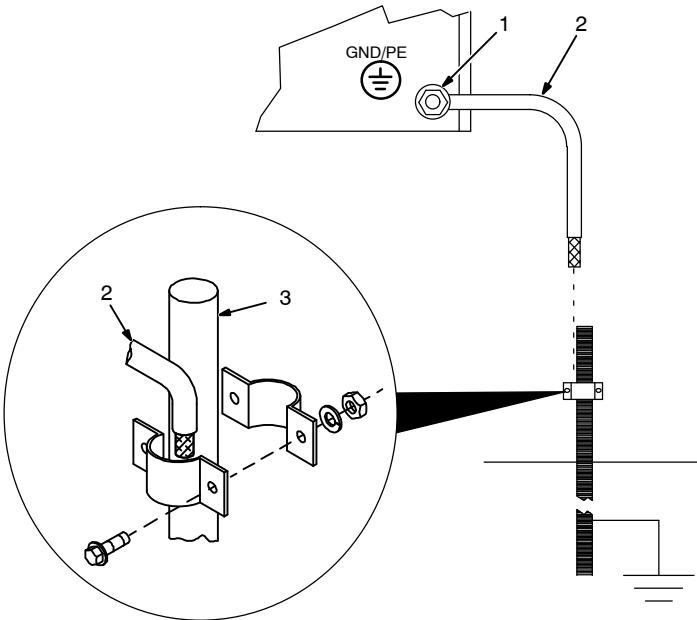

- 1 Equipment Grounding Terminal
- 2 Grounding Cable

Use #8 AWG or larger insulated copper wire.

- 3 Ground Device



Use ground device as stated in electrical codes.

**Ground generator to system earth ground if supplying power to a premises (home, shop, farm) wiring system.**

**Also see AWS Safety & Health Fact Sheet No. 29, Grounding of Portable And Vehicle Mounted Welding Generators.**

ST-800 576-B

## 12-4. How Much Power Does Equipment Require?

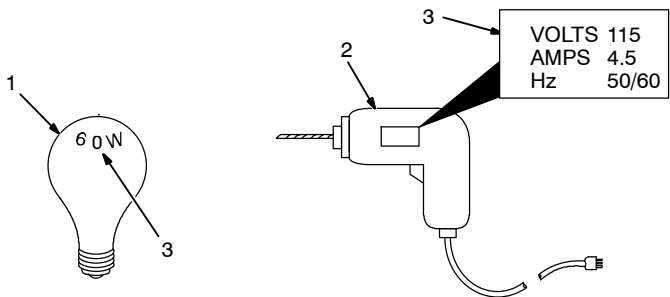

- 1 Resistive Load

A light bulb is a resistive load and requires a constant amount of power.

- 2 Non-Resistive Load

Equipment with a motor is a non-resistive load and requires approximately six times more power while starting the motor than when running (see Section 12-8).

- 3 Rating Data

Rating shows volts and amperes, or watts required to run equipment.

**Amperes x Volts = Watts**

**Example 1:** If a drill uses 4.5 amperes at 115 volts, calculate its running power requirement in watts.

$$4.5 \text{ A} \times 115 \text{ V} = 520 \text{ W}$$

The load applied by the drill is 520 watts.

**Example 2:** If three 200 watt flood lamps are used with the drill from Example 1, add the individual loads to calculate total load.

$$(3 \times 200\text{W}) + 520 \text{ W} = 1120 \text{ W}$$

The total load applied by the three flood lamps and drill is 1120 watts.

S-0623

## 12-5. Approximate Power Requirements For Industrial Motors

Industrial Motors	Rating	Starting Watts	Running Watts
Split Phase	1/8 HP	800	300
	1/6 HP	1225	500
	1/4 HP	1600	600
	1/3 HP	2100	700
	1/2 HP	3175	875
Capacitor Start-Induction Run	1/3 HP	2020	720
	1/2 HP	3075	975
	3/4 HP	4500	1400
	1 HP	6100	1600
	1-1/2 HP	8200	2200
	2 HP	10,550	2850
	3 HP	15,900	3900
Capacitor Start-Capacitor Run	5 HP	23,300	6800
	1-1/2 HP	8100	2000
	5 HP	23,300	6000
	7-1/2 HP	35,000	8000
Fan Duty	10 HP	46,700	10,700
	1/8 HP	1000	400
	1/6 HP	1400	550
	1/4 HP	1850	650
	1/3 HP	2400	800
	1/2 HP	3500	1100

## 12-6. Approximate Power Requirements For Farm/Home Equipment

Farm/Home Equipment	Rating	Starting Watts	Running Watts
Stock Tank De-Icer		1000	1000
Grain Cleaner	1/4 HP	1650	650
Portable Conveyor	1/2 HP	3400	1000
Grain Elevator	3/4 HP	4400	1400
Milk Cooler		2900	1100
Milker (Vacuum Pump)	2 HP	10,500	2800
Farm Duty Motors Std. (e.g. Conveyors, Feed Augers, Air Compressors)	1/3 HP	1720	720
	1/2 HP	2575	975
	3/4 HP	4500	1400
	1 HP	6100	1600
	1-1/2 HP	8200	2200
	2 HP	10,550	2850
	3 HP	15,900	3900
Farm Duty Motors High Torque (e.g. Barn Cleaners, Silo Unloaders, Silo Hoists, Bunk Feeders)	5 HP	23,300	6800
	1-1/2 HP	8100	2000
	5 HP	23,300	6000
	7-1/2 HP	35,000	8000
3-1/2 cu. ft. Mixer	10 HP	46,700	10,700
	1/2 HP	3300	1000
High Pressure 1.8 Gal/Min	500 PSI	3150	950
Washer 2 gal/min	550 PSI	4500	1400
	700 PSI	6100	1600
Refrigerator or Freezer		3100	800
Shallow Well Pump	1/3 HP	2150	750
	1/2 HP	3100	1000
Sump Pump	1/3 HP	2100	800
	1/2 HP	3200	1050

## 12-7. Approximate Power Requirements For Contractor Equipment

Contractor Equipment	Rating	Starting Watts	Running Watts
Hand Drill	1/4 in.	350	350
	3/8 in.	400	400
	1/2 in.	600	600
Circular Saw	6-1/2 in.	500	500
	7-1/4 in.	900	900
	8-1/4 in.	1400	1400
Table Saw	9 in.	4500	1500
	10 in.	6300	1800
Band Saw	14 in.	2500	1100
Bench Grinder	6 in.	1720	720
	8 in.	3900	1400
	10 in.	5200	1600
Air Compressor	1/2 HP	3000	1000
	1 HP	6000	1500
	1-1/2 HP	8200	2200
	2 HP	10,500	2800
Electric Chain Saw	1-1/2 HP, 12 in.	1100	1100
	2 HP, 14 in.	1100	1100
Electric Trimmer	Standard 9 in.	350	350
	Heavy Duty 12 in.	500	500
Electric Cultivator	1/3 HP	2100	700
Elec. Hedge Trimmer	18 in.	400	400
Flood Lights	HID	125	100
	Metal Halide	313	250
	Mercury	1000	
	Sodium	1400	
	Vapor	1250	1000
Submersible Pump	400 GPH	600	200
Centrifugal Pump	900 GPH	900	500
Floor Polisher	3/4 HP, 16 in.	4500	1400
	1 HP, 20 in.	6100	1600
High Pressure Washer	1/2 HP	3150	950
	3/4 HP	4500	1400
	1 HP	6100	1600
55 gal Drum Mixer	1/4 HP	1900	700
Wet & Dry Vac	1.7 HP	900	900
	2-1/2 HP	1300	1300

## 12-8. Power Required To Start Motor

Single-Phase Induction Motor Starting Requirements								
Motor Start Code	G	H	J	K	L	M	N	P
KVA/HP	6.3	7.1	8.0	9.0	10.0	11.2	12.5	14.0



AC MOTOR			
VOLTS	230	AMPS	2.5
CODE	M	Hz	60
HP	1/4	PHASE	1

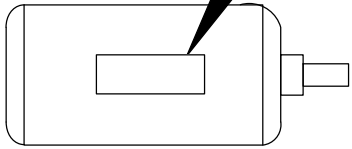

- 1 Motor Start Code
- 2 Running Amperage
- 3 Motor HP
- 4 Motor Voltage

To find starting amperage:

**Step 1:** Find code and use table to find kVA/HP. If code is not listed, multiply running amperage by six to find starting amperage.

**Step 2:** Find Motor HP and Volts.

**Step 3:** Determine starting amperage (see example).

Welder/generator amperage output must be at least twice the motor's running amperage.

**(kVA/HP x HP x 1000) / Volts = Starting Amperage**

Example: Calculate starting amperage required for a 230 V, 1/4 HP motor with a motor start code of M.

Volts = 230, HP = 1/4, kVA/HP = 11.2

$(11.2 \times 1/4 \times 1000) / 230 = 12.2A$

Starting the motor requires 12.2 amperes.

S-0624

## 12-9. How Much Power Can Generator Supply?

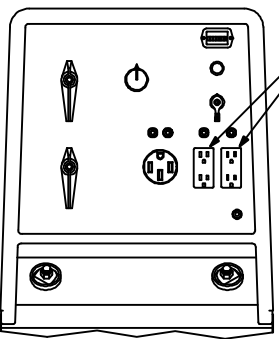
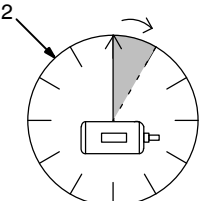

- 1 Limit Load To 90% Of Generator Output

Always start non-resistive (motor) loads in order from largest to smallest, and add resistive loads last.

- 2 5 Second Rule

If motor does not start within 5 seconds, turn off power to prevent motor damage. Motor requires more power than generator can supply.

Ref. ST-800 396-A / S-0625

## 12-10. Typical Connections To Supply Standby Power

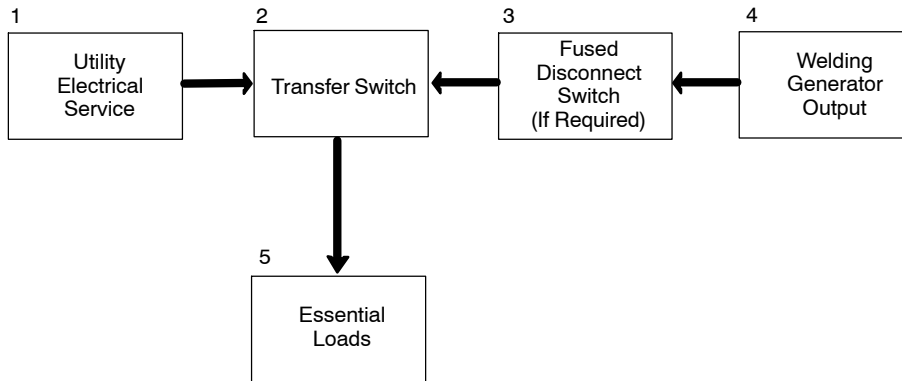

**⚠** Have only qualified persons perform these connections according to all applicable codes and safety practices.

**⚠** Properly install, ground, and operate this equipment according to its Owner's Manual and national, state, and local codes.

**⚠** Do not connect to any electrical distribution system normally supplied by utility power unless a proper transfer switch and grounding procedure are employed.

**ℹ** Customer-supplied equipment is required if generator will supply standby power during emergencies or power outages.

1 Utility Electrical Service

2 Transfer Switch (Double-Throw)

Switch transfers the electrical load from electric utility service to the generator. Transfer load back to electric utility when service is restored.

Install correct switch (customer-supplied). Switch rating must be same as or greater than the branch overcurrent protection.

3 Fused Disconnect Switch

Install correct switch (customer-supplied) if required by electrical code.

4 Welder/Generator Output

Generator output voltage and wiring must be consistent with regular (utility) system voltage and wiring.

Connect generator with temporary or permanent wiring suitable for the installation.

Turn off or unplug all equipment connected to generator before starting or stopping engine. When starting or stopping, the engine has low speed which causes low voltage and frequency.

5 Essential Loads

Generator output may not meet the electrical requirements of the premises. If generator does not produce enough output to meet all requirements, connect only essential loads (pumps, freezers, heaters, etc. – See Section 12-4).

## 12-11. Selecting Extension Cord (Use Shortest Cord Possible)

Cord Lengths for 120 Volt Loads							
							
<b>⚠ Use GFCI protection when operating auxiliary equipment. If unit does not have GFCI receptacles, use GFCI-protected extension cord. Do not use GFCI receptacles to power life support equipment.</b>							
Current (Amperes)	Load (Watts)	Maximum Allowable Cord Length In ft (m) for Conductor Size In AWG (mm <sup>2</sup> )*					
		4 (25)	6 (16)	8 (10)	10 (6)	12 (4)	14 (2.5)
5	600			350 (106)	225 (68)	137 (42)	100 (30)
7	840		400 (122)	250 (76)	150 (46)	100 (30)	62 (19)
10	1200	400 (122)	275 (84)	175 (53)	112 (34)	62 (19)	50 (15)
15	1800	300 (91)	175 (53)	112 (34)	75 (23)	37 (11)	30 (9)
20	2400	225 (68)	137 (42)	87 (26)	50 (15)	30 (9)	
25	3000	175 (53)	112 (34)	62 (19)	37 (11)		
30	3600	150 (46)	87 (26)	50 (15)	37 (11)		
35	4200	125 (38)	75 (23)	50 (15)			
40	4800	112 (34)	62 (19)	37 (11)			
45	5400	100 (30)	62 (19)				
50	6000	87 (26)	50 (15)				

\*Conductor size is based on maximum 2% voltage drop

Cord Lengths for 240 Volt Loads							
							
<b>⚠ Use GFCI protection when operating auxiliary equipment. If unit does not have GFCI receptacles, use GFCI-protected extension cord. Do not use GFCI receptacles to power life support equipment.</b>							
Current (Amperes)	Load (Watts)	Maximum Allowable Cord Length In ft (m) for Conductor Size In AWG (mm <sup>2</sup> )*					
		4 (25)	6 (16)	8 (10)	10 (6)	12 (4)	14 (2.5)
5	1200			700 (213)	450 (137)	225 (84)	200 (61)
7	1680		800 (244)	500 (152)	300 (91)	200 (61)	125 (38)
10	2400	800 (244)	550 (168)	350 (107)	225 (69)	125 (38)	100 (31)
15	3600	600 (183)	350 (107)	225 (69)	150 (46)	75 (23)	60 (18)
20	4800	450 (137)	275 (84)	175 (53)	100 (31)	60 (18)	
25	6000	350 (107)	225 (69)	125 (38)	75 (23)		
30	7000	300 (91)	175 (53)	100 (31)	75 (23)		
35	8400	250 (76)	150 (46)	100 (31)			
40	9600	225 (69)	125 (38)	75 (23)			
45	10,800	200 (61)	125 (38)				
50	12,000	175 (53)	100 (31)				

\*Conductor size is based on maximum 2% voltage drop

# SECTION 13 – STICK WELDING (SMAW) GUIDELINES

## 13-1. Stick Welding Procedure

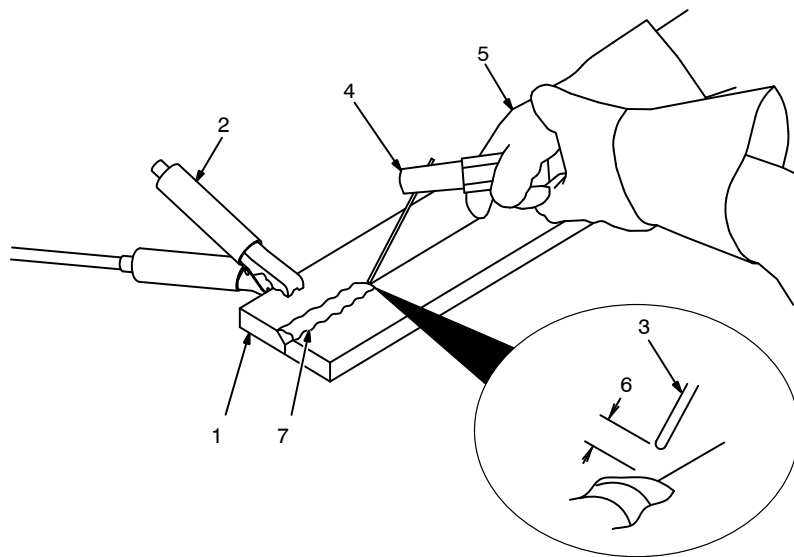
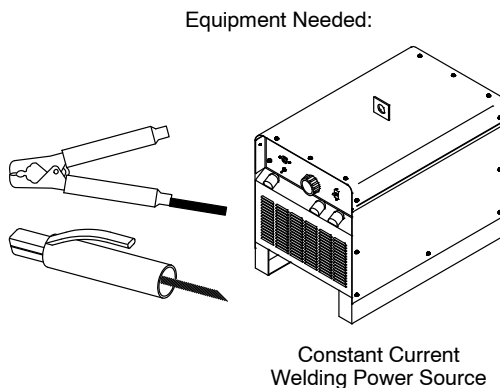
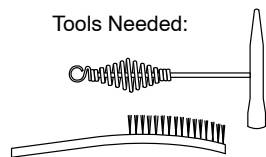
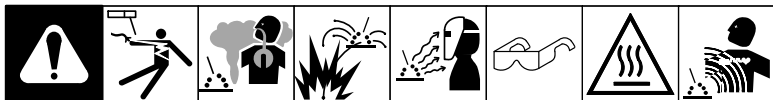

**⚠** Weld current starts when electrode touches work-piece.

**⚠** Weld current can damage electronic parts in vehicles. Disconnect both battery cables before welding on a vehicle. Place work clamp as close to the weld as possible.

**📖** Always wear appropriate personal protective clothing.

1 Workpiece

Make sure workpiece is clean before welding.

2 Work Clamp

Place as close to the weld as possible.

3 Electrode

Before striking an arc, insert an electrode in the electrode holder. A small diameter electrode requires less current than a large one. Follow recommendations of the electrode manufacturer when setting weld amperage (see Section 13-2).

4 Insulated Electrode Holder

5 Electrode Holder Position

6 Arc Length

Arc length is the distance from the electrode to the workpiece. A short arc with correct amperage will give a sharp, crackling sound. Correct arc length is related to electrode diameter. Examine the weld bead to determine if the arc length is correct.

Arc length for 1/16 and 3/32 in. diameter electrodes should be about 1/16 in. (1.6 mm); arc length for 1/8 and 5/32 in. electrodes should be about 1/8 in. (3 mm).

7 Slag

Use a chipping hammer and wire brush to remove slag. Remove slag and check weld bead before making another weld pass.

### 13-2. Electrode And Amperage Selection Chart

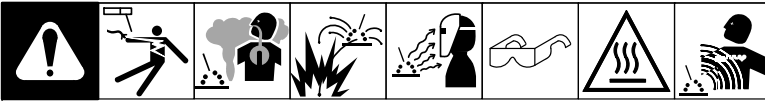

ELECTRODE	DIAMETER	AMPERAGE RANGE								
		50	100	150	200	250	300	350	400	450
6010 & 6011	3/32									
	1/8									
	5/32									
	3/16									
	7/32									
6013	1/4									
	1/16									
	5/64									
	3/32									
	1/8									
	5/32									
	3/16									
7014	7/32									
	1/4									
	3/32									
	1/8									
	5/32									
7018	3/16									
	7/32									
	1/4									
	3/32									
	1/8									
7024	5/32									
	3/16									
	7/32									
	1/4									
	3/32									
Ni-CI	1/8									
	5/32									
	3/16									
	3/32									
308L	1/8									
	5/32									

ELECTRODE	DC*	AC	POSITION	PENETRATION	USAGE
6010	EP		ALL	DEEP	MIN. PREP, ROUGH HIGH SPATTER
6011	EP	✓	ALL	DEEP	
6013	EP,EN	✓	ALL	LOW	GENERAL
7014	EP,EN	✓	ALL	MED	SMOOTH, EASY, FAST
7018	EP	✓	ALL	MED	LOW HYDROGEN, STRONG
7024	EP,EN	✓	FLAT HORIZ*	LOW	SMOOTH, EASY, FASTER
NI-CL	EP	✓	ALL	LOW	CAST IRON
308L	EP	✓	ALL	LOW	STAINLESS

\*EP = ELECTRODE POSITIVE (REVERSE POLARITY)  
EN = ELECTRODE NEGATIVE (STRAIGHT POLARITY)

Ref. S-087 985-A

### 13-3. Striking An Arc

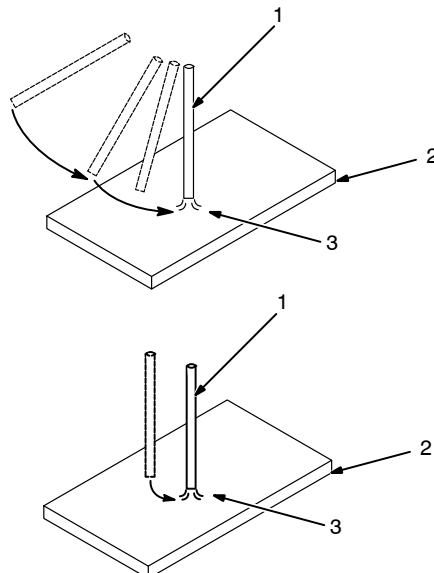
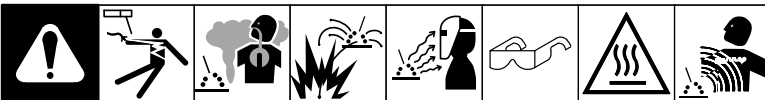

**⚠ Weld current starts when electrode touches workpiece.**

- 1 Electrode
- 2 Workpiece
- 3 Arc

#### Scratch Technique

Drag electrode across workpiece like striking a match; lift electrode slightly after touching work. If arc goes out, electrode was lifted too high. If electrode sticks to workpiece, use a quick twist to free it.

#### Tapping Technique

Bring electrode straight down to workpiece; then lift slightly to start arc. If arc goes out, electrode was lifted too high. If electrode sticks to workpiece, use a quick twist to free it.

S-0049 / S-0050

### 13-4. Positioning Electrode Holder

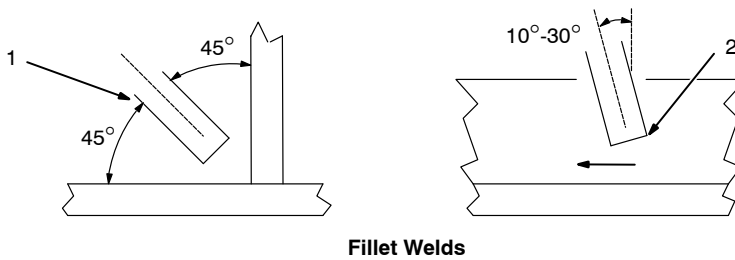
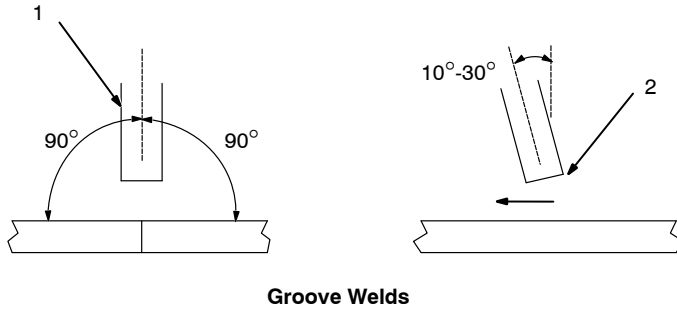
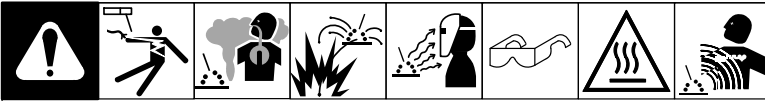

- 1 End View Of Work Angle
- 2 Side View Of Electrode Angle

After learning to start and hold an arc, practice running beads of weld metal on flat plates using a full electrode.

Hold the electrode nearly perpendicular to the work, although tilting it ahead (in the direction of travel) will be helpful.

*To produce the best results, hold a short arc, travel at a uniform speed, and feed the electrode downward at a constant rate as it melts.*

S-0060

### 13-5. Poor Weld Bead Characteristics

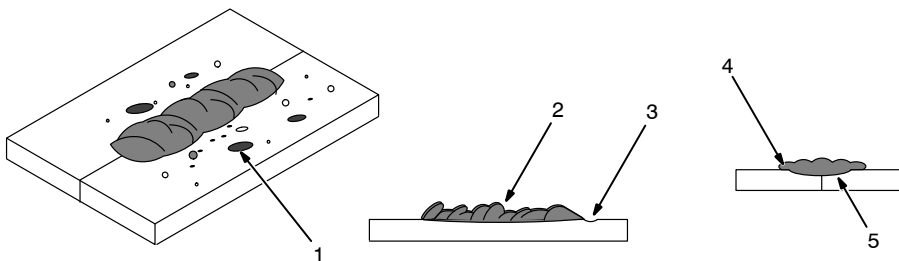
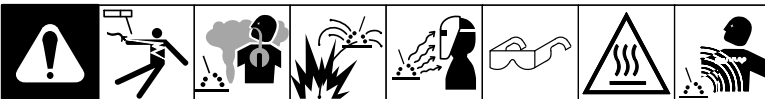

- 1 Large Spatter Deposits
- 2 Rough, Uneven Bead
- 3 Slight Crater During Welding
- 4 Bad Overlap
- 5 Poor Penetration

S-0053-A

### 13-6. Good Weld Bead Characteristics

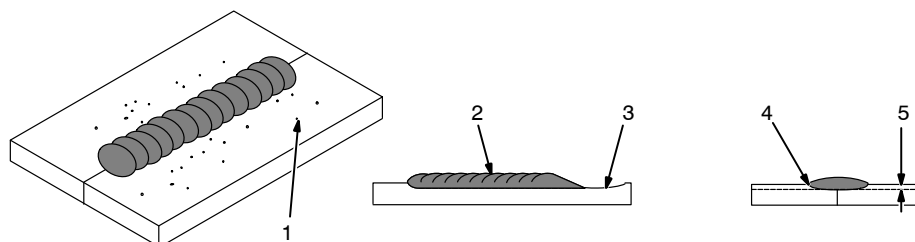
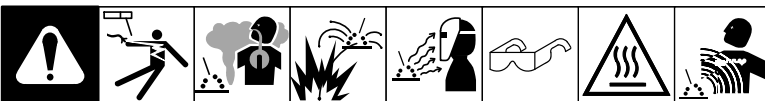

- 1 Fine Spatter
- 2 Uniform Bead
- 3 Moderate Crater During Welding

Weld a new bead or layer for each 1/8 in. (3.2 mm) thickness in metals being welded.

- 4 No Overlap
- 5 Good Penetration into Base Metal

S-0052-B

### 13-7. Conditions That Affect Weld Bead Shape

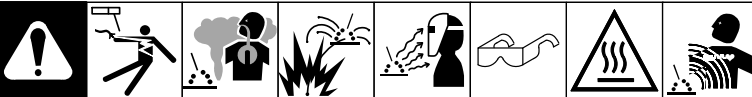

☞ *Weld bead shape is affected by electrode angle, arc length, travel speed, and thickness of base metal.*

**Electrode Angle**

Angle Too Small      Correct Angle  $10^{\circ} - 30^{\circ}$       Angle Too Large

→ Drag

**Arc Length**

Too Short      Normal      Too Long (Spatter)

**Travel Speed**

Slow      Normal      Fast

S-0061

### 13-8. Electrode Movement During Welding

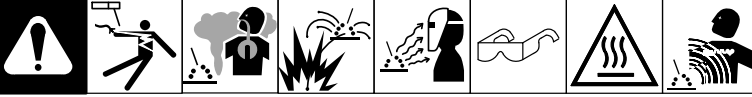

☞ *Normally, a single stringer bead is satisfactory for most narrow groove weld joints; however, for wide groove weld joints or bridging across gaps, a weave bead or multiple stringer beads work better.*

1 Stringer Bead – Steady Movement Along Seam

2 Weave Bead – Side to Side Movement Along Seam

3 Weave Patterns

Use weave patterns to cover a wide area in one pass of the electrode. Do not let weave width exceed 2-1/2 times diameter of electrode.

S-0054-A

### 13-9. Welding Lap Joints



1 Electrode

2 Single-Layer Fillet Weld

Move electrode in circular motion.

3 Multi-Layer Fillet Weld

Weld a second layer when a heavier fillet is needed. Remove slag before making another weld pass. Weld both sides of joint for maximum strength.

$30^{\circ}$  Or Less

S-0063 / S-0064

## 13-10. Welding Groove (Butt) Joints

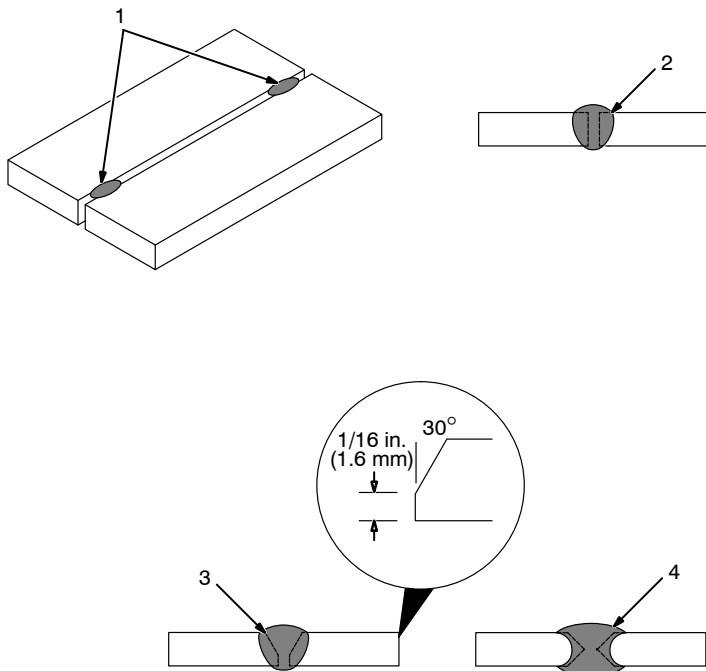
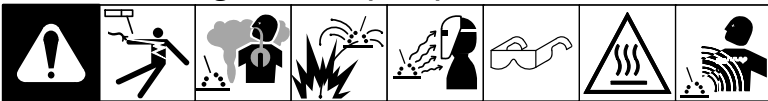

### 1 Tack Welds

Prevent butt joint distortion by tack welding the materials in position before final weld.

Workpiece distortion occurs when heat is applied locally to a joint. One side of a metal plate will curl up toward the weld. Distortion will also cause the edges of a butt joint to pull together ahead of the electrode as the weld cools.

### 2 Square Groove Weld

### 3 Single V-Groove Weld

### 4 Double V-Groove Weld

Materials up to 3/16 in. (5 mm) thick can often be welded without special preparation using the square groove weld. However, when welding thicker materials it may be necessary to prepare the edges (V-groove) of butt joints to ensure good welds.

The single or double V-groove weld is good for materials 3/16 – 3/4 in. (5-19 mm) thick. Generally, the single V-groove is used on materials up to 3/4 in. (19 mm) thick and when, regardless of thickness, you can weld from one side only. Create a 30 degree bevel with oxy-acetylene or plasma cutting equipment. Remove scale from material after cutting. A grinder can also be used to prepare bevels.

S-0062

## 13-11. Welding T-Joints

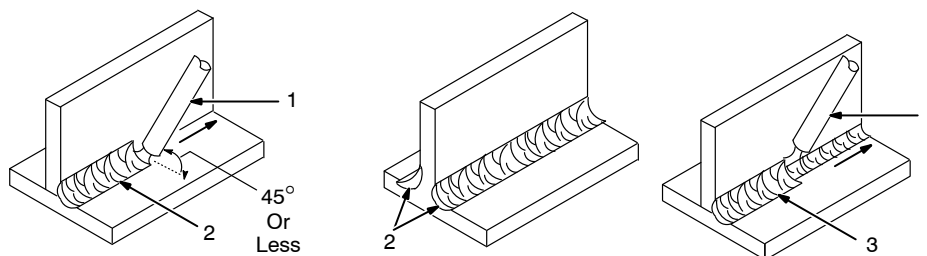

### 1 Electrode

### 2 Fillet Weld

Keep arc short and move at definite rate of speed. Hold electrode as shown to provide fusion into the corner. Square edge of the weld surface.

For maximum strength weld both sides of upright section.

### 3 Multi-Layer Deposits

Weld a second layer when a heavier fillet is needed. Use any of the weaving patterns shown in Section 13-8. Remove slag before making another weld pass.

S-0060 / S-0058-A / S-0061

### 13-12. Weld Test

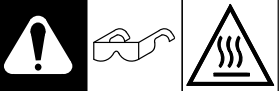

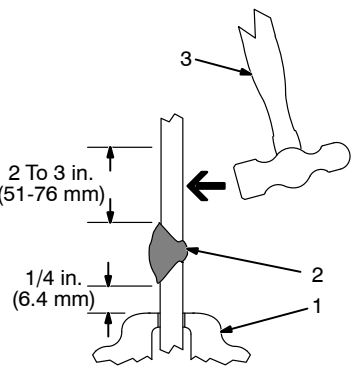

1 Vise  
2 Weld Joint  
3 Hammer

Strike the weld joint in the direction shown. A good weld bends over but does not break.

If the weld breaks, examine it to determine the cause.

If the weld is porous (many holes), the arc length was probably too long.



If the weld contains bits of slag, the arc may have been too long or the electrode was moved incorrectly which allowed molten slag to be trapped in the weld. This may happen on a V-groove joint made in several layers and calls for additional cleaning between layers.

If the original beveled surface is visible the material was not fully melted which is often caused by insufficient heat or too fast a travel speed.

S-0057-B

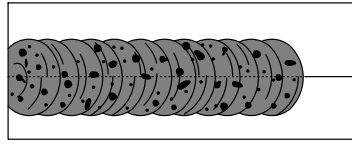
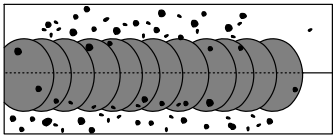
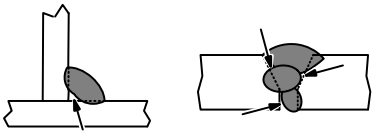
### 13-13. Troubleshooting

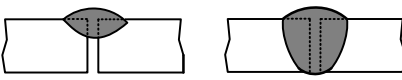
	<p><b>Porosity</b> – small cavities or holes resulting from gas pockets in weld metal.</p>
<p><b>Possible Causes</b></p> <p>Arc length too long.</p> <p>Damp electrode.</p> <p>Workpiece dirty.</p>	<p><b>Corrective Actions</b></p> <p>Reduce arc length.</p> <p>Use dry electrode.</p> <p>Remove all grease, oil, moisture, rust, paint, coatings, slag, and dirt from work surface before welding.</p>
	<p><b>Excessive Spatter</b> – scattering of molten metal particles that cool to solid form near weld bead.</p>
<p><b>Possible Causes</b></p> <p>Amperage too high for electrode.</p> <p>Arc length too long or voltage too high.</p>	<p><b>Corrective Actions</b></p> <p>Decrease amperage or select larger electrode.</p> <p>Reduce arc length or voltage.</p>
	<p><b>Incomplete Fusion</b> – failure of weld metal to fuse completely with base metal or a preceding weld bead.</p>
<p><b>Possible Causes</b></p> <p>Insufficient heat input.</p> <p>Improper welding technique.</p>	<p><b>Corrective Actions</b></p> <p>Increase amperage. Select larger electrode and increase amperage.</p> <p>Place stringer bead in proper location(s) at joint during welding.</p> <p>Adjust work angle or widen groove to access bottom during welding.</p> <p>Momentarily hold arc on groove side walls when using weaving technique.</p> <p>Keep arc on leading edge of weld puddle.</p>
<p>Workpiece dirty.</p>	<p>Remove all grease, oil, moisture, rust, paint, coatings, slag, and dirt from work surface before welding.</p>

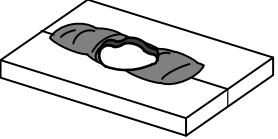
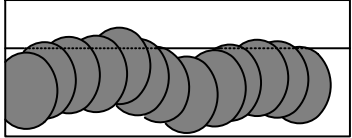
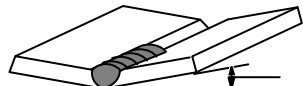
 <p>Lack of Penetration      Good Penetration</p>	<p><b>Lack Of Penetration</b> – shallow fusion between weld metal and base metal.</p>
<p><b>Possible Causes</b></p>	<p><b>Corrective Actions</b></p>
<p>Improper joint preparation.</p>	<p>Material too thick. Joint preparation and design must provide access to bottom of groove.</p>
<p>Improper weld technique.</p>	<p>Keep arc on leading edge of weld puddle.</p>
<p>Insufficient heat input.</p>	<p>Increase amperage. Select larger electrode and increase amperage.</p>
	<p>Reduce travel speed.</p>
 <p>Excessive Penetration      Good Penetration</p>	<p><b>Excessive Penetration</b> – weld metal melting through base metal and hanging underneath weld.</p>
<p><b>Possible Causes</b></p>	<p><b>Corrective Actions</b></p>
<p>Excessive heat input.</p>	<p>Select lower amperage. Use smaller electrode.</p>
	<p>Increase and/or maintain steady travel speed.</p>
	<p><b>Burn-Through</b> – weld metal melting completely through base metal resulting in holes where no metal remains.</p>
<p><b>Possible Causes</b></p>	<p><b>Corrective Actions</b></p>
<p>Excessive heat input.</p>	<p>Select lower amperage. Use smaller electrode.</p>
	<p>Increase and/or maintain steady travel speed.</p>
	<p><b>Waviness Of Bead</b> – weld metal that is not parallel and does not cover joint formed by base metal.</p>
<p><b>Possible Causes</b></p>	<p><b>Corrective Actions</b></p>
<p>Unsteady hand.</p>	<p>Use two hands. Practice technique.</p>
 <p>Base metal moves in the direction of the weld bead.</p>	<p><b>Distortion</b> – contraction of weld metal during welding that forces base metal to move.</p>
<p><b>Possible Causes</b></p>	<p><b>Corrective Actions</b></p>
<p>Excessive heat input.</p>	<p>Use restraint (clamp) to hold base metal in position.</p>
	<p>Make tack welds along joint before starting welding operation.</p>
	<p>Select lower amperage for electrode.</p>
	<p>Increase travel speed.</p> <p>Weld in small segments and allow cooling between welds.</p>



Effective January 1, 2019

### Warranty Questions?

Call  
1-800-332-3281  
8 AM – 5 PM EST

### Service

You always get the fast, reliable response you need. Most replacement parts can be in your hands in 24 hours.

### Support

Need fast answers to the tough welding questions? Contact your distributor or call 1-800-332-3281. The expertise of the distributor and Hobart is there to help you, every step of the way.

### Assistance

Visit the Hobart website:  
[www.HobartWelders.com](http://www.HobartWelders.com)

5/3/1 WARRANTY applies to all Hobart welding equipment, plasma cutters and spot welders with a serial number preface of MK or newer.

This limited warranty supersedes all previous Hobart warranties and is exclusive with no other guarantees or warranties expressed or implied.

Hobart products are serviced by Hobart or Miller Authorized Service Agencies.

**LIMITED WARRANTY** – Subject to the terms and conditions below, Miller Electric Mfg. LLC, dba Hobart Welding Products, Appleton, Wisconsin, warrants to its original retail purchaser that new Hobart equipment sold after the effective date of this limited warranty is free of defects in material and workmanship at the time it is shipped. **THIS WARRANTY IS EXPRESSLY IN LIEU OF ALL OTHER WARRANTIES, EXPRESS OR IMPLIED, INCLUDING THE WARRANTIES OF MERCHANTABILITY AND FITNESS.**

Within the warranty periods listed below, Hobart/Miller will repair or replace any warranted parts or components that fail due to such defects in material or workmanship. Hobart/Miller must be notified in writing within thirty (30) days of such defect or failure, at which time Hobart/Miller will provide instructions on the warranty claim procedures to be followed. Notifications submitted as online warranty claims must provide detailed descriptions of the fault and troubleshooting steps taken to diagnose failed parts. Warranty claims that lack the required information as defined in the Miller Service Operation Guide (SOG) may be denied by Miller.

Hobart/Miller shall honor warranty claims on warranted equipment listed below in the event of a defect within the warranty coverage time periods listed below. Warranty time periods start on the delivery date of the equipment to the original retail purchaser, or 12 months after the equipment is shipped to a North American or international distributor, whichever occurs first.

1. 5 Years — Parts and Labor
  - \* Original Main Power Rectifiers only to include SCRs, diodes, and discrete rectifier modules
  - \* Reactors
  - \* Stabilizers
  - \* Transformers
2. 3 Years — Parts and Labor Unless Specified
  - \* Drive Systems
  - \* Idle Module
  - \* PC Boards
  - \* Rotors, Stators and Brushes
  - \* Solenoid Valves
  - \* Spot Welder Transformer
  - \* Switches and Controls
  - \* MIG Flowgauge Regulators (No Labor)
3. 1 Year — Parts and Labor Unless Specified (90 days for industrial use)
  - \* Accessories (Kits)
  - \* Batteries (Trek 180 Only)
  - \* Contactors
  - \* Field Options  
(NOTE: Field options are covered for the remaining warranty period of the product they are installed in, or for a minimum of one year — whichever is greater.)
  - \* HF Units
  - \* MIG Guns/TIG Torches
  - \* Motor-Driven Guns
  - \* Plasma Cutting Torches
  - \* Relays
  - \* Remote Controls
  - \* Replacement Parts (No labor) – 90 days
  - \* Running Gear/Trailers
  - \* Water Cooling Systems
  - \* Spoolguns

4. 6 Months — Parts
  - \* Batteries
5. Engines and tires are warranted separately by the manufacturer.

Hobart's 5/3/1 Limited Warranty shall not apply to:

1. **Consumable components; such as contact tips, cutting nozzles, contactors, brushes, relays, work station table tops and welding curtains, or parts that fail due to normal wear. (Exception: brushes and relays are covered on all engine-driven products.)**
2. Items furnished by Hobart/Miller, but manufactured by others, such as engines or trade accessories. These items are covered by the manufacturer's warranty, if any.
3. Equipment that has been modified by any party other than Hobart/Miller, or equipment that has been improperly installed, improperly operated or misused based upon industry standards, or equipment which has not had reasonable and necessary maintenance, or equipment which has been used for operation outside of the specifications for the equipment.
4. Defects caused by accident, unauthorized repair, or improper testing.

**HOBART PRODUCTS ARE INTENDED FOR COMMERCIAL AND INDUSTRIAL USERS TRAINED AND EXPERIENCED IN THE USE AND MAINTENANCE OF WELDING EQUIPMENT.**

The exclusive remedies for warranty claims are, at Hobart's/Miller's option, either: (1) repair; or (2) replacement; or, if approved in writing by Hobart/Miller, (3) the pre-approved cost of repair or replacement at an authorized Hobart/Miller service station; or (4) payment of or credit for the purchase price (less reasonable depreciation based upon use). Products may not be returned without Hobart's/Miller's written approval. Return shipment shall be at customer's risk and expense.

The above remedies are F.O.B. Appleton, WI, or Hobart's/Miller's authorized service facility. Transportation and freight are the customer's responsibility. TO THE EXTENT PERMITTED BY LAW, THE REMEDIES HEREIN ARE THE SOLE AND EXCLUSIVE REMEDIES REGARDLESS OF THE LEGAL THEORY. IN NO EVENT SHALL HOBART/MILLER BE LIABLE FOR DIRECT, INDIRECT, SPECIAL, INCIDENTAL OR CONSEQUENTIAL DAMAGES (INCLUDING LOSS OF PROFIT) REGARDLESS OF THE LEGAL THEORY. ANY WARRANTY NOT PROVIDED HEREIN AND ANY IMPLIED WARRANTY, GUARANTY, OR REPRESENTATION, INCLUDING ANY IMPLIED WARRANTY OF MERCHANTABILITY OR FITNESS FOR PARTICULAR PURPOSE, ARE EXCLUDED AND DISCLAIMED BY HOBART/MILLER.

Some US states do not allow limiting the duration of an implied warranty or the exclusion of certain damages, so the above limitations may not apply to you. This warranty provides specific legal rights, and other rights may be available depending on your state. In Canada, some provinces provide additional warranties or remedies, and to the extent the law prohibits their waiver, the limitations set out above may not apply. This Limited Warranty provides specific legal rights, and other rights may be available, but may vary by province.





Thank you for purchasing Hobart. Our trained technical support team is dedicated to your satisfaction. For questions regarding performance, operation, or service, contact us!

## Resources Available

Always provide Model Name and Serial/Style Number.

### To locate a Service Center:

Call 1-800-332-3281  
or visit our website at [www.HobartWelders.com/wheretobuy](http://www.HobartWelders.com/wheretobuy)

### For Technical Assistance:

Call 1-800-332-3281  
8 AM to 5 PM EST – Monday through Friday



## Owner's Record

Please complete and retain with your personal records.

Model Name	Serial/Style Number
Purchase Date	(Date which equipment was delivered to original customer.)
Distributor	
Address	
City	
State	Zip

### Miller Electric Mfg. LLC

An Illinois Tool Works Company  
1635 West Spencer Street  
Appleton, WI 54914 USA

**For Assistance:**  
Call 1-800-332-3281

