

LAGUNA®

PX|20 Sheartec:ll Planer



Owner's Manual
MPLANPX20-0130
2/25/2021



For immediate service on any Laguna Tools products:
+1 (949) 474-1200
customerservice@lagunatools.com

Laguna Tools, Inc. LAGUNA® and the LAGUNA Logo® are the registered trademarks of Laguna Tools, Inc. All rights reserved. 04/01/2019



LAGUNA AMERICAN HEADQUARTERS

Texas: 744 Refuge Way Suite 200, Grand Prairie, Texas 75050, U.S.A. Phone:

+1-800-332-4094

Huntington Beach: 7291 Heil Ave Huntington Beach, CA 92647, U.S.A. Phone:

+1-949-474-1200

South Carolina: 825 Bistline Dr. Ste 101, West Columbia, SC 29172, U.S.A. Phone:

+1-800-234-1976

Minnesota: 5250 West 74th St, Edina, MN 55439, U.S.A Phone: +1-949-474-1200

lagunatools.com

supermaxtools.com

lagunacleanair.com

lagunalathe.com

LAGUNA EUROPE

Walker Rd, Bardonia Hill, Coalville LE67 1TU, United Kingdom. Phone: +44-1530-516921

lagunatools.uk

DAKE CORPORATION

724 Robbins Road, Grand Haven, MI 49417, United States +1-800-937-3253

dakecorp.com





CONTENTS

PX|20 Sheartec:II Planer

Safety	4
Electrical Safety	7
Specifications	11
Machine Overview	12
Setup	14
Placement & Unboxing	14
Inventory List	16
Assembling	17
Operation	23
Maintenance	24
Lubrication	32
Troubleshooting	33
Wiring	34
Replacement Parts Diagram	36
Replacement Parts Table	39
Warranty	45

Safety

Read and understand all warnings and operation instructions before using any tool or equipment. Always follow basic safety precautions to reduce the risk of personal injury. Improper operation, maintenance or modification of tools or equipment could result in serious injury and property damage. There are certain applications for which tools and equipment are designed. This product should NOT be modified and/or used for any application other than for which it was designed.

It is important for you to read and understand this manual. The information it contains relates to protecting your safety and preventing problems.

Safety Call-outs

⚠ DANGER!

A POTENTIALLY HAZARDOUS SITUATION WHICH, IF NOT AVOIDED, COULD RESULT IN DEATH OR SERIOUS INJURY.
SOMETIMES DISPLAYED AS **⚠ DANGER!**

⚠ WARNING

A POTENTIALLY HAZARDOUS SITUATION WHICH, IF NOT AVOIDED, COULD RESULT IN DEATH OR SERIOUS INJURY.
SOMETIMES DISPLAYED AS **⚠ WARNING!**











⚠ CAUTION!

A POTENTIALLY HAZARDOUS SITUATION WHICH, IF NOT AVOIDED, MAY RESULT IN MINOR OR MODERATE INJURY.
SOMETIMES DISPLAYED AS **⚠ CAUTION!**

NOTICE!

A HELPFUL TIP FROM OUR TECHNICAL STAFF. SOMETIMES DISPLAYED AS NOTICE!

Safety Symbols

- | | | | |
|---|--|---|--------------------------|
|  | Disconnect from power before proceeding. |  | Wear ear protection. |
|  | Be aware of possible laceration danger. |  | Wear Eye Protection. |
|  | Be aware of possible crushing danger. |  | Wear a full face shield. |
|  | Be aware of possible crushing danger. |  | Wear lung protection. |
|  | Electrical Hazard. |  | Requires X People |

PROP 65 WARNING

SOME DUST CREATED BY POWER SANDING, SAWING, GRINDING, DRILLING, AND OTHER CONSTRUCTION ACTIVITIES CONTAINS CHEMICALS KNOWN TO THE STATE OF CALIFORNIA TO CAUSE CANCER, BIRTH DEFECTS OR OTHER REPRODUCTIVE HARM. SOME EXAMPLES OF THESE CHEMICALS ARE:

- LEAD FROM LEAD-BASED PAINTS.
- CRYSTALLINE SILICA FROM BRICKS, CEMENT AND OTHER MASONRY PRODUCTS.
- ARSENIC AND CHROMIUM FROM CHEMICALLY-TREATED LUMBER.

YOUR RISK FROM THESE EXPOSURES VARIES, DEPENDING ON HOW OFTEN YOU DO THIS TYPE OF WORK. TO REDUCE YOUR EXPOSURE TO THESE CHEMICALS: WORK IN A WELL VENTILATED AREA, AND WORK WITH APPROVED SAFETY EQUIP-MENT, SUCH AS THOSE DUST MASKS THAT ARE SPECIALLY DESIGNED TO FILTER OUT MICROSCOPIC PARTICLES.

APPLICATIONS WARNING

- THIS MACHINE WAS DESIGNED FOR CERTAIN APPLICATIONS ONLY. WE STRONGLY RECOMMEND THAT THIS MACHINE NOT BE MODIFIED AND/OR USED FOR ANY APPLICATION OTHER THAN THAT FOR WHICH IT WAS DESIGNED. IF YOU HAVE ANY QUESTIONS RELATIVE TO A PARTICULAR APPLICATION, DO NOT USE THE MACHINE UNTIL YOU HAVE FIRST CONTACTED THE MANUFACTURER TO DETERMINE IF IT CAN OR SHOULD BE PERFORMED ON THE PRODUCT.
- IF YOU HAVE ANY QUESTIONS RELATIVE TO ITS APPLICATION DO NOT USE THE PRODUCT UNTIL YOU HAVE CONTACTED THE MANUFACTURER AND WE HAVE ADVISED YOU.

WARNING!

Machine & Workshop Safety Instructions

Read and understand all warnings and operating instructions before using this equipment. Failure to follow all instructions listed below, may result in electric shock, fire, and/or serious personal injury or property damage. Machinery can be dangerous if safe and proper operating procedures are not followed. As with all machinery, there are certain hazards involved with the operation of the product. Using the machine with respect and caution will considerably lessen the possibility of personal injury. However, if normal safety precautions are overlooked or ignored, personal injury to the operator may result. Safety equipment such as guards, push sticks, hold-downs, feather boards, goggles, dust masks and hearing protection can reduce your potential for injury. But even the best guard won't make up for poor judgment, carelessness or inattention. Always use common sense and exercise caution in the workshop. If a procedure feels dangerous, don't try it. Figure out an alternative procedure that feels safer. REMEMBER: Your personal safety is your responsibility.

OWNER'S MANUAL. Read and understand this owner's manual BEFORE using machine.

TRAINED OPERATORS ONLY. Untrained operators have a higher risk of being hurt or killed. Only allow trained/supervised people to use this machine. When machine is not being used, disconnect power, remove switch keys, or lock-out machine to prevent unauthorized use—especially around children. Make your workshop kid proof!

DANGEROUS ENVIRONMENTS. Do not use machinery in areas that are wet, cluttered, or have poor lighting. Operating machinery in these areas greatly increases the risk of accidents and injury.

MENTAL ALERTNESS REQUIRED. Full mental alertness is required for safe operation of machinery. Never operate under the influence of drugs or alcohol, when tired, or when distracted.

ELECTRICAL EQUIPMENT INJURY RISKS. You can be shocked, burned, or killed by touching live electrical components or improperly grounded machinery. To reduce this risk, only allow qualified service personnel to do electrical installation or repair work, and always disconnect power before accessing or exposing electrical equipment.

DISCONNECT POWER FIRST. Always disconnect machine from power supply BEFORE making adjustments, changing tooling, or servicing machine. This prevents an injury risk from unintended start-up or contact with live electrical components.

EYE PROTECTION. Always wear ANSI-approved safety glasses or a face shield when operating or observing machinery to reduce the risk of eye injury or blindness from flying particles. Everyday eyeglasses are NOT approved safety glasses.

WEARING PROPER APPAREL. Do not wear clothing, apparel or jewelry that can become entangled in moving parts. Always tie back or cover long hair. Wear non-slip footwear to reduce risk of slipping and losing control or accidentally contacting cutting tool or moving parts.

HAZARDOUS DUST. Dust created by machinery operations may cause cancer, birth defects, or long-term respiratory damage. Be aware of dust hazards associated with each workpiece material. Always wear a NIOSH-approved respirator to reduce your risk.

HEARING PROTECTION. Always wear hearing protection when operating or observing loud machinery. Extended exposure to this noise without hearing protection can cause permanent hearing loss.

REMOVE ADJUSTING TOOLS. Tools left on machinery can become dangerous projectiles upon startup. Never leave chuck keys, wrenches, or any other tools on machine. Always verify removal before starting!

USE CORRECT TOOL FOR THE JOB. Only use this tool for its intended purpose—do not force it or an attachment to do a job for which it was not designed. Never make unapproved modifications, modifying tool or using it differently than intended may result in malfunction or mechanical failure that can lead to personal injury or death!

AWKWARD POSITIONS. Keep proper footing and balance at all times when operating machine. Do not overreach! Avoid awkward hand positions that make workpiece control difficult or increase the risk of accidental injury.

CHILDREN & BYSTANDERS. Keep children and bystanders at a safe distance from the work area. Stop using machine if they become a distraction.

GUARDS & COVERS. Guards and covers reduce accidental contact with moving parts or flying debris. Make sure they are properly installed, undamaged, and working correctly BEFORE operating machine.

FORCING MACHINERY. Do not force machine. It will do the job safer and better at the rate for which it was designed.

NEVER STAND ON MACHINE. Serious injury may occur if machine is tipped or if the cutting tool is unintentionally contacted.

STABLE MACHINE. Unexpected movement during operation greatly increases risk of injury or loss of control. Before starting, verify machine is stable and mobile base (if used) is locked.

USE RECOMMENDED ACCESSORIES. Consult this owner's manual or the manufacturer for recommended accessories. Using improper accessories will increase the risk of serious injury.

UNATTENDED OPERATION. To reduce the risk of accidental injury, turn machine OFF and ensure all moving parts completely stop before walking away. Never leave machine running while unattended.

MAINTAIN WITH CARE. Follow all maintenance instructions and lubrication schedules to keep machine in good working condition. A machine that is improperly maintained could malfunction, leading to serious personal injury or death.

DAMAGED PARTS. DAMAGED PARTS. Regularly inspect machine for damaged, loose, or improperly adjusted parts—or any condition that could affect safe operation.

MAINTAIN POWER CORDS. When disconnecting cord-connected machines from power, grab and pull the plug—NOT the cord. Pulling the cord may damage the wires inside. Do not handle cord/plug with wet hands. Avoid cord damage by keeping it away from heated surfaces, high traffic areas, harsh chemicals, and wet/damp locations.

SAVE THESE INSTRUCTIONS.
Refer to them often and use them to instruct others.

Electrical Safety

⚠ WARNING!

- RUNNING ON A DIFFERENT VOLTAGE THAN STATED BELOW WILL DAMAGE THE MACHINE. NEVER RUN THE MACHINE IN WET OR DAMP CONDITIONS.
- ELECTROCUTION, FIRE, SHOCK, OR EQUIPMENT DAMAGE MAY OCCUR IF MACHINE IS NOT PROPERLY GROUNDED AND CONNECTED TO POWER SUPPLY.

Power Supply

A separate electrical circuit should be used for each machine. This circuit should not be less than the wiring listed below and should be protected with an appropriate circuit breaker based on the total running and start-up amperage's (listed below). If an extension cord is used, use only 3-wire extension cords which have 3-prong grounding type plugs and matching receptacle which will accept the machine's plug.

MPLANPX20-0130

VOLTAGE	220V
PHASE	1PH
HERTZ	60Hz
FULL LOAD AMPERAGE	23 AMPS

⚠ WARNING! Below are RECOMMENDATIONS to be used for this machine based on the above information. Variables that may affect this are:

- Actual voltage supplied to the machine
- Electrical code that must be met in your local province.

An electrician will verify that all the demands are met to properly wire the machine. If you have absolutely any doubt when wiring this machine - please consult with a qualified electrician.

PLUG/RECEPTACLE	Not Included
WIRING (Gauge)	See Jacket Printing
CIRCUIT BREAKER	30 Amp Minimum

If this information is different than what is stated on the Motor Specification Plate - omit this information. It is possible that the documentation is outdated to a machine change - such as a different motor. Always check the motor plate prior to any wiring. If any doubts, please consult a certified electrician.

Know when to use a time delay fuse! AKA Slow blow fuse. Generally, if the motor uses a start capacitor, a time delay fuse is required. This type of fuse (circuit breaker) will not trip with the initial amperage needed to start the machine, which is typically double that of the running amperage. Most woodworking machines use this type of fuse.

Grounding Methods

⚠ DANGER!

THIS MACHINE MUST BE GROUNDED WHILE IN USE TO PROTECT THE OPERATOR FROM ELECTRIC SHOCK. IN ALL CASES, MAKE CERTAIN THAT THE RECEPTACLE IN QUESTION IS PROPERLY GROUNDED. IF YOU ARE NOT SURE, HAVE A QUALIFIED ELECTRICIAN CHECK THE RECEPTACLE.

Grounding Methods Provided by CSA Group. (A) Receptacle with nominal rating less than 150 volts. (B) 150 volt receptacle without grounding pin fitted with adapter. (C) 150-250 volt receptacle.

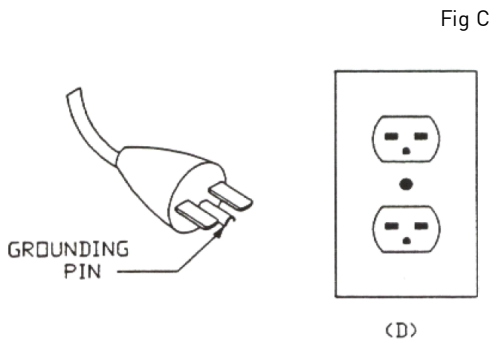
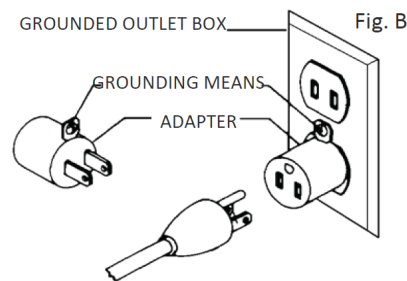
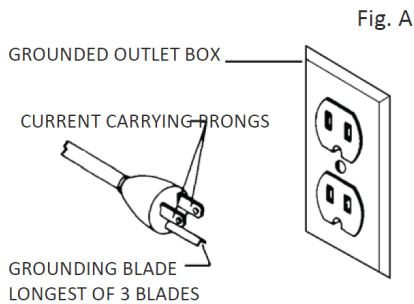

1. All grounded, cord-connected machines:

In the event of a malfunction or breakdown, grounding provides a path of least resistance for electric current to reduce the risk of electric shock. This tool is equipped with an electric cord having an equipment-grounding conductor and a grounding plug. The plug must be plugged into a matching outlet that is properly installed and grounded in accordance with all local codes and ordinances.

Do not modify the plug provided - if it will not fit the outlet, have the proper outlet installed by a qualified electrician.

Improper connection of the equipment-grounding conductor can result in a risk of electric shock. The conductor with insulation having an outer surface that is green with or without yellow stripes is the equipment-grounding conductor. If repair or replacement of the electric cord or plug is necessary, do not connect the equipment-grounding conductor to a live terminal.

Check with a qualified electrician or service personnel if the grounding instructions are not completely understood, or if in doubt as to whether the tool is properly grounded.

Use only 3-wire extension cords that have 3-prong grounding plugs and 3 pole receptacles that accept the tool's plug.

Repair or replace damaged or worn cord immediately.

2. Grounded, cord-connected machines intended for use on a supply circuit having a nominal rating less than 150 volts:

This tool is intended for use on a circuit that has an outlet that looks like the one illustrated in Fig. A. The tool has a grounding plug that looks like the plug illustrated in Fig A. A temporary adapter, which looks like the adapter illustrated in Fig B may be used to connect this plug to a 2 pole receptacle as shown in Fig B if a properly grounded outlet is not available. The temporary adapter should be used only until a properly grounded outlet can be installed by a qualified electrician. This adapter is not permitted in Canada. The green-colored rigid ear, lug, and the like, extending from the adapter must be connected to a permanent ground such as a properly grounded outlet box.

3. Grounded, cord-connected tools intended for use on a supply circuit having a nominal rating between 150 – 250 volts, inclusive:

This tool is intended for use on a circuit that has an outlet that looks like the one illustrated in Fig C. The tool has a grounding plug that looks like the plug illustrated in Fig C. Make sure the tool is connected to an outlet having the same configuration as the plug. No adapter is available or should be used with this tool. If the tool must be reconnected for use on a different type of electric circuit, the reconnection should be made by qualified service personnel; and after reconnection, the tool should comply with all local codes and ordinances.

Extension Cords

⚠ WARNING! Use proper extension cords. Make sure your extension cord is in good condition and is a 3-wire extension cord which has a 3-prong grounding type plug and matching receptacle which will accept the machine’s plug. When using an extension cord, be sure to use one heavy enough to carry the current of the machine. An undersized cord will cause a drop in line voltage, resulting in loss of power and overheating. If in doubt, use the next heavier gauge. The smaller the gauge number, the heavier the cord.

MINIMUM GAUGE EXTENSION CORD 120V

RECOMMENDED SIZES FOR USE WITH STATIONARY ELECTRIC MACHINES

Ampere Rating	Volts	Total Length of Cord in Feet	Gauge of Extension Cord
0-6	120	up to 25	18 AWG
0-6	120	25-50	16 AWG
0-6	120	50-100	16 AWG
0-6	120	100-150	14 AWG
6-10	120	up to 25	18 AWG
6-10	120	25-50	16 AWG
6-10	120	50-100	14 AWG
6-10	120	100-150	12 AWG
10-12	120	up to 25	16 AWG
10-12	120	25-50	16 AWG
10-12	120	50-100	14 AWG
10-12	120	100-150	12 AWG
12-16	120	up to 25	14 AWG
12-16	120	25-50	12 AWG
12-16	120	GREATER THAN 50 FEET NOT RECOMMENDED	

MINIMUM GAUGE EXTENSION CORD 240V

RECOMMENDED SIZES FOR USE WITH STATIONARY ELECTRIC MACHINES

Ampere Rating	Volts	Total Length of Cord in Feet	Gauge of Extension Cord
0-6	240	up to 50	18 AWG
0-6	240	50-100	16 AWG
0-6	240	100-200	16 AWG
0-6	240	200-300	14 AWG
6-10	240	up to 50	18 AWG
6-10	240	50-100	16 AWG
6-10	240	100-200	14 AWG
6-10	240	200-300	12 AWG
10-12	240	up to 50	16 AWG
10-12	240	50-100	16 AWG
10-12	240	100-200	14 AWG
10-12	240	200-300	12 AWG
12-16	240	up to 50	14 AWG
12-16	240	50-100	12 AWG
12-16	240	GREATER THAN 100 FEET NOT RECOMMENDED	

Specifications

PX|20 Sheartec:II Planer

MPLANPX20-0130

VOLT HP PHASE HERTZ AMP 230V 5HP 1PHASE 60HZ/23AMP.

CSA	YES
BED SIZE	20 X 21-1/2"
PULL-OUT EXTENSION	4"
WHEELS BUILT-IN	OPTIONAL
MAX. DEPHT OF CUT	1/4"
MAX. STOCK THICKNESS	8"
MIN. STOCK THICKNESS	1/4"
MIN. STOCK LENGTH	8"
MAX. STOCK WIDTH	20"
FEED SPEED	16 & 28 FPM
DUST PORT DIAMETER	4" LEFT AND RIGHT
CUTTERHEAD RPM	5000
CUTTERHEAD DIAMETER	3"
CUTTERHEAD INSERT #	138 X 4-SIDED CARBIDE, 6 ROW
THICKNESS READOUT	WIXEY DRO
DIMENSIONS SET UP APPROX.	36" X 36"
DIMENSIONS SHIPPING	42"X30"X46"
NET/SHIP WEIGHT # OF BOXES	LBS. 535/638 1BOX
SWITCH:	ON/OFF FOR MAIN MOTOR
PACKING SIZE: (L X W X H)	25" X 17" X 21.5" {635 X 432 X 546 MM}
MACHINE WEIGHT:	65 LBS. (30 KG.)
SHIPPING WEIGHT:	72 LBS. (33 KG.)

Machine Overview

PX|20 Sheartec:II Planer

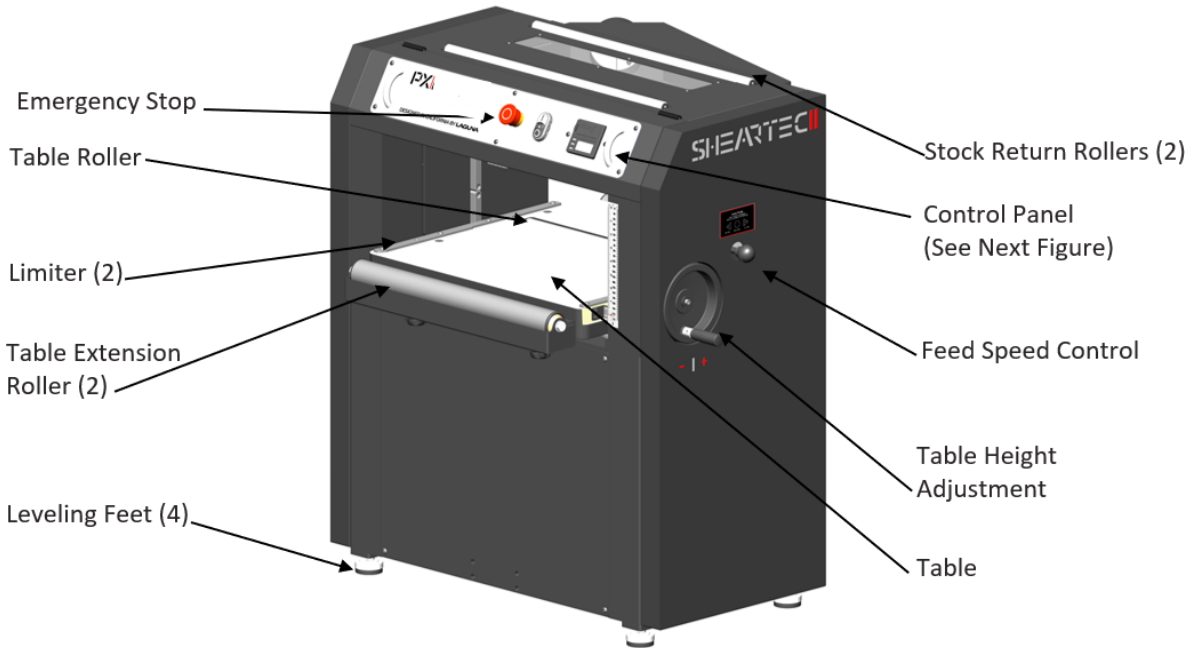
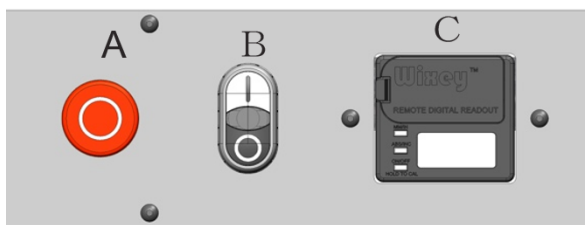

Figure 6: Main Components of PX20



- A. Emergency Stop (E-STOP); stops all functions of machine, however, power continues to machine. **NOTICE!** To reset E-STOP, rotate switch clockwise until the button “pops” out.
- B. ON/OFF Switch; Starts and Stops rotation of cutterhead. **NOTICE!** Will not work if the ESTOP is engaged or if the Hood is open.
- C. Digital Read Out (DRO); Thickness display

Limiter

The Limiter (Fig. 6) acts as a stop to prevent the cutterhead from contacting the table and to prevent stock from sliding past the edge of the cutterhead.

Table Rollers

The Rollers act as a stop to reduce the chance of stock from sliding past the edge of the cutterhead or table.

Extension Rollers

Adjustable rollers that extend for increased workpiece support.

Feed Speed Selector

CAUTION!

AS WITH ALL GEAR BOX SHIFTERS, IT IS VERY IMPORTANT TO ONLY CHANGE SPEEDS WHEN THE MACHINE IS RUNNING.

The feed speed selector offers two feed speeds, 16 FPM & 28 FPM. Move lever (push/pull) until it locks in place. The middle setting is neutral.

Thickness Gauge

The top of the planer is a Wixey thickness gauge. Material thickness can be quickly identified by placing it on edge into the various gauges and reading the corresponding measurement.

Stock Return Rollers

Allows users to return stock back to feed zone quickly and safely with less strain on workers.

Setup

Setup Overview (MUST READ)

When setting up your PX|20 Sheartec:II Planer, please take a moment to read this overview prior to starting.

The machine comes mostly assembled. You will have to assemble the leveling feet, the dust chute, and calibrate the height.

After Setup, There may be a few adjustment to be made. All of these adjustments are done prior to shipping the machine, but if additional adjustments are required, please follow the adjustment guides.

⚠ CAUTION! If you have any doubt about the described procedure, seek professional assistance. Do not attempt any procedure that you feel is unsafe, or that you do not have the physical capability of achieving.

Placement & Unboxing

Your Machine will likely be delivered by a third party delivery service. Before unpacking your new machine, first inspect the packaging, the invoice, and the shipping documents supplied by the driver. When unpacking your machine, separate all enclosed items from the packing materials and inspect them for damages. Ensure that there is no visible damage to either the packaging or the machine BEFORE the driver leaves. Save all packaging materials until you are satisfied with the machine and/or have resolved any issues concerning any missing or damaged items.

NOTICE!

- ALL SHIPPING DAMAGE MUST BE NOTED UPON DELIVERY AND SIGNED BY THE OWNER AND THE DELIVERY DRIVER. IF YOU FIND ANY DAMAGED ITEMS IN YOUR PACKAGE, YOU MUST CONTACT LAGUNA TOOLS TO FILE A COMPLAINT. IN ORDER TO RETURN DAMAGED GOODS UNDER THE LIMITED WARRANTY TO LAGUNA TOOLS, INC., YOU MUST HAVE THE ORIGINAL PACKAGING. ALL CLAIMS OF LOSS OR DAMAGED GOODS MUST BE REPORTED TO LAGUNA TOOLS WITHIN 24 HOURS OF DELIVERY. PLEASE CONTACT THE LAGUNA TOOLS, INC. CUSTOMER SERVICE DEPARTMENT TO MAKE CLAIMS FOR ANY DAMAGED ITEMS/PARTS.
- IT IS PROBABLE THAT YOU WILL FIND SAWDUST WITHIN YOUR MACHINE. THIS IS BECAUSE THE MACHINE HAS BEEN TESTED PRIOR TO SHIPMENT FROM THE FACTORY AND OR LAGUNA TOOLS. WE TEST MACHINES PRIOR TO SHIPPING TO CUSTOMERS, BUT MOVEMENT CAN TAKE PLACE DURING TRANSPORTATION. SOME ADJUSTMENTS MAY HAVE TO BE UNDERTAKEN BY THE CUSTOMER. THESE ADJUSTMENTS ARE COVERED IN THE VARIOUS SECTIONS OF THIS MANUAL.

Placement

Before you remove your machine from the packaging, select the area where you will use your machine. There are no hard and fast rules for its location, but below are a few guidelines:

1. There should be sufficient area at the front of the machine to allow you to work on it comfortably.
2. There should be sufficient area at the back of the machine to allow access for adjustments and maintenance to be conducted.
3. Adequate lighting. The better the lighting the more accurately and safely you will be able to work.
4. Solid floor. You should select a solid flat floor, preferably one made of concrete or something similar.

5. Locate it close to a power source and dust collection.
6. Allow an area for the storage of blanks, finished products and tools.

Unboxing

⚠ WARNING!

- THE MACHINE WEIGHS 638 LBS (289KG). ENSURE THAT YOU HAVE ENOUGH PEOPLE TO DO THE JOB SAFELY.
- IF YOU HAVE ANY DOUBT ABOUT THE DESCRIBED PROCEDURE, SEEK PROFESSIONAL ASSISTANCE. DO NOT ATTEMPT ANY PROCEDURE THAT YOU FEEL IS UNSAFE, OR THAT YOU DO NOT HAVE THE PHYSICAL CAPABILITY OF ACHIEVING.

This step requires a forklift. The PX20 is heavy, be careful when lifting and handling it! Failure to comply may cause serious injury and/or damage to the machine and/or property! Use a forklift to remove PX20 from pallet and place on floor.

NOTE: Another option to remove the planer from the pallet is to attach the included hooks to frame of machine at each of the four corners (Fig. 1). The hooks and bolts are included in the hardware kit. The machine can then be lifted with a harness and forklift. Remove and save hooks for later movement scenarios.

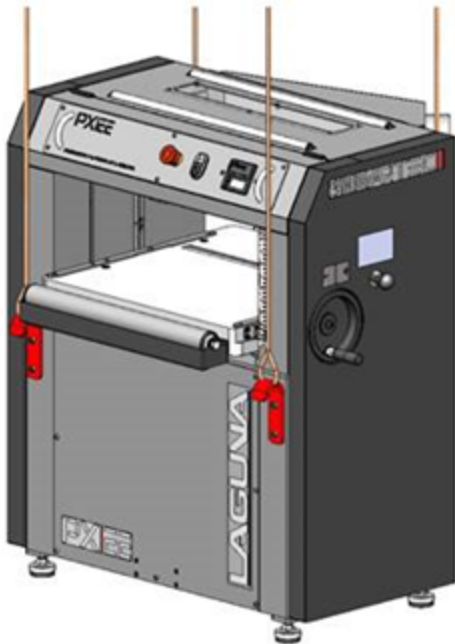

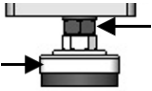
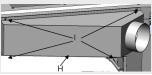



FIGURE 1: LIFTING PLANER WITH HOOKS AND HARNESS



FIGURE 2: PALLET

Inventory List

The following depicts items shipped with your machine. Before assembling, ensure that you have received all parts shown below. Machine parts should arrive sealed in plastic bags. Remove parts from plastic bags before laying them out to inventory them.

REF	Description	Q	Packaging
	Leveling Feet with Hardware	4	On Paller
	Dust Chute	1	In Bubble Wrap
	Hex Head Screws M6x10	4	In Bubble Wrap
	T25 Torx Wrenches	2	In Bubble Wrap
	Lifting hooks & hardware	4	In Bubble Wrap

Tools/items Required: Assembly & Adjustment

- T-25 Torx wrench, included
- 9/16" wrench
- 1/2" wrench
- 5mm hex wrench
- Power Cord and Plug (unless hard wiring into a disconnect)

⚠ DANGER!

FOR YOUR OWN SAFETY, DO NOT CONNECT THE MACHINE TO THE POWER SOURCE UNTIL THE MACHINE IS COMPLETELY ASSEMBLED! PLEASE ALSO MAKE SURE THAT YOU READ AND UNDERSTAND THE ENTIRE MANUAL.

Assembling

Machine Preparation and Setup:

1. Level machine using the four leveling feet on each of the four corners. Lock leveling feet into position with the nut on the leveling foot stud (Fig. 3).

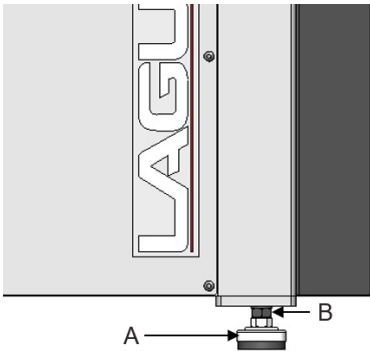

FIGURE 3: LEVELING FEET

(OPTIONAL) If Installing Unverisal Casters

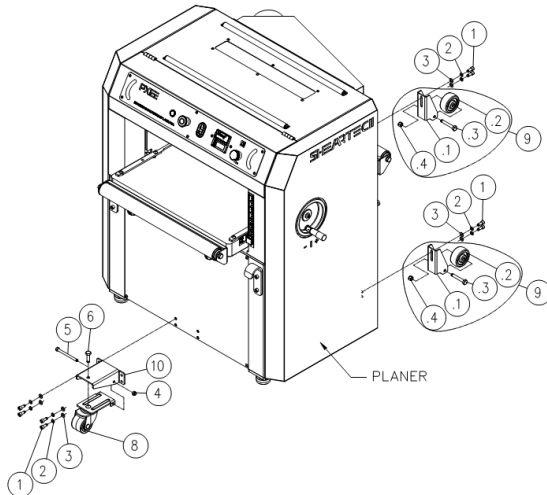

FIGURE 28: CASTER INSTALLATION

Installing universal caster set (Fig. 28):

1. Raise and block planer for attaching caster set.
2. Assemble swivel caster into swivel caster bracket (straight bracket) by placing bolt #5 through bracket and caster and securing with lock nut #4. Then place bolt #6 down through bracket into caster mount.
3. Attach swivel caster to front (infeed) center of frame with four bolts #1, washers #2 and nuts #3. Tighten all four bolts.
4. Assemble caster (wheel) #.2 to bracket #.1 using bolt #.3 and nut #.4. Repeat this process for second caster.
5. Attach caster assembly #9 to rear (outfeed) side of frame using two bolts #1, two washers #2 and two nuts #3. Repeat process for both casters. Tighten all four bolts.
6. Carefully remove blocks with planer resting on casters.

2. Clean all rust protected surfaces with a commercial de-greaser. DO NOT use acetone, gasoline, lacquer thinner or any type of cleaner that could damage paint. Coat cleaned surfaces with WD-40® or 20W machine oil.
3. Table Roller adjustment: Turn the knobs (Fig. 4, G) to move the table roller up or down to the desired position. **NOTICE!** The roller is typically set higher when planing rough stock. When planing smooth stock, the roller should be set slightly above, or flush with the table.

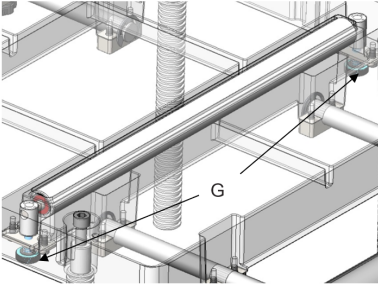

FIGURE 4: TABLE ROLLER
ADJUSTMENT

4. The dust chute can be attached with the port facing either to the right or left. To attach use four included screws (Fig. 5, H) to mount to the rear (outfeed) side of the planer head.

NOTICE!

MAKE SURE THE DUST COLLECTION SYSTEM HAS SUFFICIENT CAPACITY AND CFM FOR THIS PLANER. ALWAYS TURN ON THE DUST COLLECTOR BEFORE PLANING.

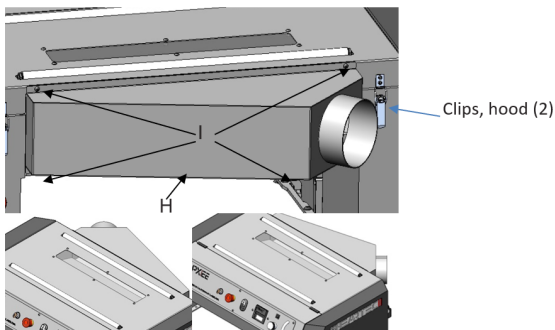

FIGURE 5: DUST CHUTE & HOOD CLIPS

Opening Hood

1. Release the 2 Clips (Fig. 5) on each side of the hood.
2. Remove the two lower screws holding the dust chute in place (Fig. 5)
3. Raise hood until automatic latch secures hood in open position
4. To close, press IN automatic latch while lowering hood

Power Supply Circuit Requirements

The power source circuit for your machine must be grounded and rated for the amperage given below. Never replace a circuit breaker on an existing circuit with one of higher amperage without consulting a qualified electrician to ensure compliance with wiring codes. If you are unsure about the wiring codes in your area or you plan to connect your machine to a shared circuit, consult a qualified electrician.

Circuit Size (208-230V, Single Phase)30 Amp (minimum)

DANGER!

IN ALL CASES, MAKE CERTAIN THE RECEPTACLE IN QUESTION IS PROPERLY GROUNDED. IF YOU ARE NOT SURE, HAVE A QUALIFIED ELECTRICIAN CHECK THE RECEPTACLE.

Motor Specifications

The typical main motor is 5 HP and is typically wired for 220 Volt, Single Phase, 60 HZ, AC current. Confirm your motor electrical configuration before connecting power! Before connecting the machine to the power source, make sure the starter and switches are in the "OFF" position. Cord and "plug" are NOT included. These must be installed by a qualified technician/electrician to local codes.

NOTICE! A "plug" and cord are NOT included and must be installed by a qualified technician/electrician or the power cable connected (hard wired) to an appropriate disconnect according to local codes.

WARNING

WHEN COMPLETED, THE MACHINE MUST CONFORM TO THE NATIONAL ELECTRIC CODE AND ALL LOCAL CODES AND ORDINANCES.

Connecting Power (See also wiring diagram page 33)

1. Remove screws securing cover to connection box.
2. Insert power cable through strain relief, tighten cinch nut and attach wires to terminals.
3. Re-install the connection box cover, see page 33 for wiring diagram.

WARNING

DISCONNECT POWER SUPPLY TO PLANER BEFORE CONTINUING! ONLY CONNECT POWER WHEN REQUIRED.

Calibrating the Thickness Scale

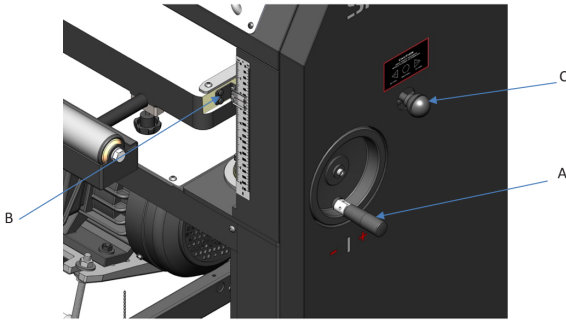

FIGURE 8: THICKNESS SCALE CALIBRATION

NOTICE! The following procedures describe the use of a “calibrating board”. It is a piece of hardwood which has been surfaced on one side with a jointer, drum sander or wide belt sander.

1. With the planer OFF, the cutter head not rotating and power disconnected, place the Calibrating Board on the table, with the previously machined (flat) face “down”, and slide under the cutterhead.

1. Make sure the Carriage Lock is unlocked (UP position).
2. Use the Table Height Adjustment handle (Fig. 8, A) to raise the table until the infeed roller is approximately 1/16” above the calibrating board.
3. Remove the calibrating board from the planer.
4. Connect power to the planer and turn ON.
5. Turn the height adjustment handle clockwise, one complete revolution, to lower the carriage and run the calibrating board (previously machined face “down”) through the planer. Lock (“down” position) the carriage lock.
6. Repeat Step 5 until the planer removes the entire top surface of the calibrating board. NOTICE! Drawing pencil marks across the width of the top of the calibrating board in several locations can make it easier to determine when the entire surface has been planed.
7. Measure the thickness of the calibrating board with a caliper.
8. Loosen the two screws of the Thickness Scale pointer and adjust the pointer (Fig. 8, B) until it corresponds to the measured thickness and tighten the screws.

Calibrating the DRO (Digital Read Out)

1. Remove the battery cover of the DRO and install 2 AAA batteries.

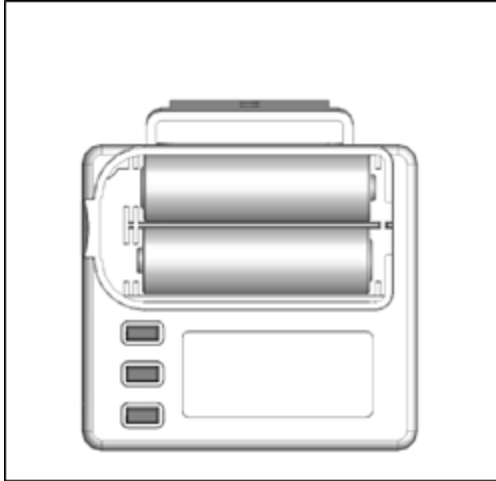

FIGURE 9: DRO BATTERIES

DRO Button Reference and Use

It is helpful to familiarize these buttons and their purpose with the Wixey™ DRO

ON/OFF and CALIBRATION



- PUSH MOMENTARILY TO TURN OFF AND ON
- HOLD FOR 3-5 SECONDS TO ENTER CALIBRATION MODE. THE "ABS IN" FLASHES
- TO CHANGE THE DISPLAY VALUE FROM 0.000 USE THE + OR - BUTTONS.

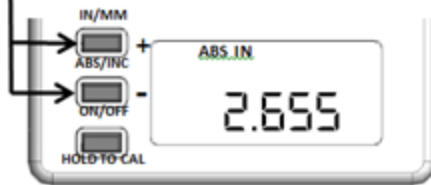

- A SHORT PRESS INCREASES ONE DIGIT. HOLDING THE BUTTON COUNTS FAST.
- PRESS THE ON/OFF BUTTON MOMENTARILY TO SET THE CALIBRATION VALUE. THE "ABS IN" WILL STOP FLASHING

FIGURES 10-12: DRO ADJUSTMENT

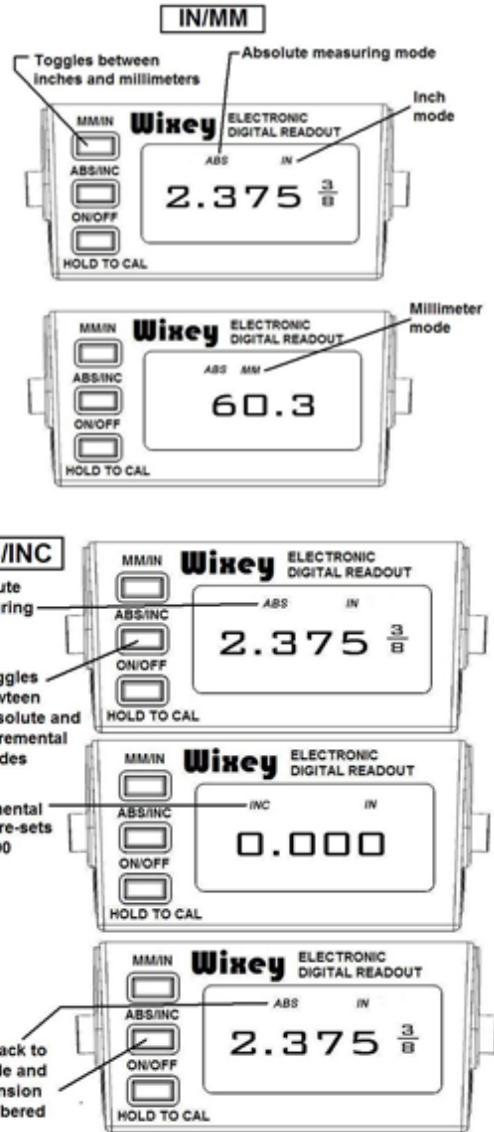

Operation

⚠ CAUTION!

PLACE THE PLANER ON A SECURE AND STABLE SURFACE FOR OPERATION. CLAMP OR BOLT THE PLANER INTO POSITION.

1. Establish the proper depth of cut (typically less than 1/16"), using either the DRO or scale.
2. Pull out and lock each extension roller to support long stock
3. Start dust collection.
4. Start planer.
5. Adjust feed speed (Fig. 8, C) to desired speed (16 or 28 FPM), while planer is running.
6. Feed stock into planer, maintain control and support of stock until the stock is securely feeding through planer.
7. Reposition yourself to the outfeed side of planer and control and support stock until it has exited the outfeed roller.

Helpful Tips

- PLANERS WORK BEST IF ONE FACE OF STOCK IS FLAT. IF NOT, FLATTEN WITH A JOINTER OR DRUM SANDER.
- IF NOT POSSIBLE TO FLATTEN ONE FACE, PROCESS CUPPED MATERIAL WITH THE CUP "UP" SO THE MATERIAL IS STABLE ON THE PLANER BED.
- IF MATERIAL IS SEVERELY CUPPED, ANOTHER OPTION IS TO RIP THE MATERIAL, PLANE IT AND GLUE IT BACK TOGETHER.
- PLANE WITH THE DIRECTION OF GRAIN TO REDUCE TEAR-OUT AND PROVIDE THE BEST SURFACE FINISH.

Maintenance

General

Keep your machine clean. At the end of each day, clean the machine. Wood contains moisture, and if sawdust or wood chips are not removed they will cause rust.

In general, we recommend that you only use a Teflon-based lubricant on the planer. Regular oil attracts dust and dirt. Teflon lubricant tends to dry and has less of a tendency to accumulate dirt and sawdust.

Periodically check that all nuts and bolts are tight.

Routine Inspections

It is a good idea to routinely inspect any quality woodworking tool in order to keep it in optimum condition. This includes inspecting all hardware for tightness, ensuring the filter is clean, and cleaning debris and grime from any surfaces and moving parts. In addition, make sure to:

- Clean out-feed rollers and table with a non- flammable solvent to remove pitch, gum and other unwanted build-up.
- Periodically clean the inside of the machine for dust control.
- Keep pulleys and belts free from dirt, dust, oil and grease.
- Replace worn belts as needed.
- Replace or rotate worn knives.
- There is one limit switch on the planer that triggers if the hood is opened. Keep it clean and blown out with an air hose.

Sheartec II Knife rotation/replacement

⚠ CAUTION!

KNIFE INSERTS ARE DANGEROUSLY SHARP. USE EXTREME CAUTION WHEN INSPECTING, REMOVING, OR REPLACING KNIFE INSERTS.

⚠ WARNING

- TURN PLANER OFF AND DISCONNECT POWER BEFORE PERFORMING ANY MAINTENANCE OR ADJUSTMENTS!
- MAKE SURE ALL KNIFE INSERT SCREWS ARE TIGHTENED SECURELY. LOOSE INSERTS CAN BE PROPELLED AT HIGH SPEED FROM A ROTATING CUTTERHEAD, CAUSING INJURY.
TORQUE EACH SCREW TO 52-60 IN/LBS.
- KNIVES ARE EXTREMELY SHARP. BE VERY CAREFUL WHEN HANDLING KNIVES. FAILURE TO COMPLY MAY CAUSE SERIOUS INJURY

The knife inserts on the Planer are four-sided. When dull, remove each knife, rotate it 90° for a fresh edge, and re-install it. No further adjustment is necessary. Use a Torx wrench (T25) to remove the knife insert screw. Use a second Torx wrench to hold the cutterhead (from rotating) in position (in another screw).

⚠ WARNING! DO NOT USE YOUR HAND TO HOLD THE CUTTERHEAD! See Fig. 13.

It is advisable to rotate all inserts at the same time to maintain consistent cutting. However, if one or more knife inserts develops a nick, rotate only those inserts that are affected. Each knife insert has an etched reference mark so you can keep track of the rotation. **Torque each screw to 52-60 in/lbs.**

IMPORTANT! When removing or rotating inserts, clean sawdust from the screw, the insert, and the cutterhead platform. Dust accumulation between these elements can prevent the insert from seating properly, and may affect the quality of the cut.

Before installing each screw, lightly coat the screw threads with machine oil and wipe off any excess. Securely tighten each screw which holds the knife inserts before operating the jointer!



FIGURE 13: CUTTERHEAD

Conveying Rollers

⚠ WARNING

- TURN PLANER OFF AND DISCONNECT POWER BEFORE PERFORMING ANY MAINTENANCE OR ADJUSTMENTS!

MAINTENANCE: Keep rollers clean to help prevent slippage of material. Be careful not to contact cutterhead knives as they are very sharp!

ADJUSTMENTS: The planer comes set-up from the factory and typically will not need adjustment. If it is determined adjustment is needed, follow these steps for setting the infeed roller, chip breaker, pressure bar and outfeed roller; 1. Make a hardwood block to the specifications in drawings (Figures 14 & 15). Use this wood gauge along with 0.02" feeler gauge to set the planer up as shown in Fig. 16.

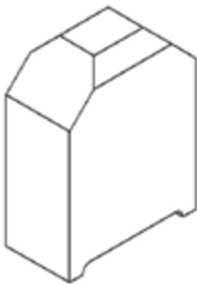

FIGURES 14 & 15: SET-UP-BLOCK

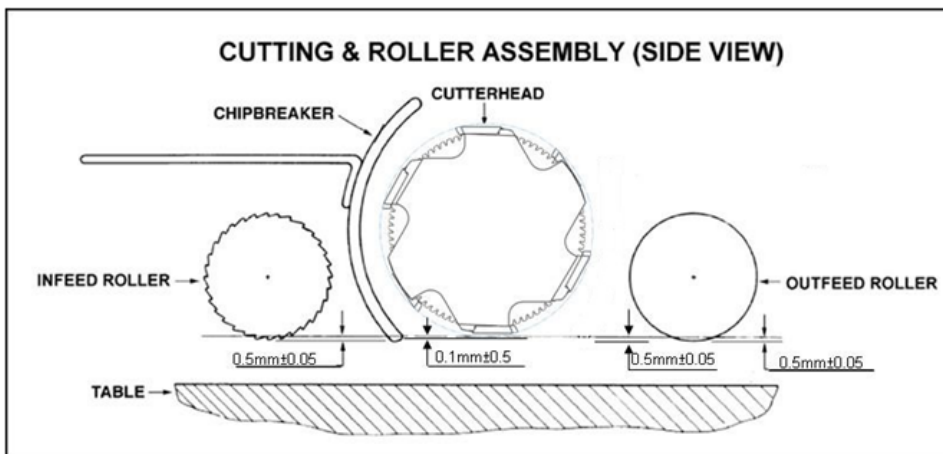
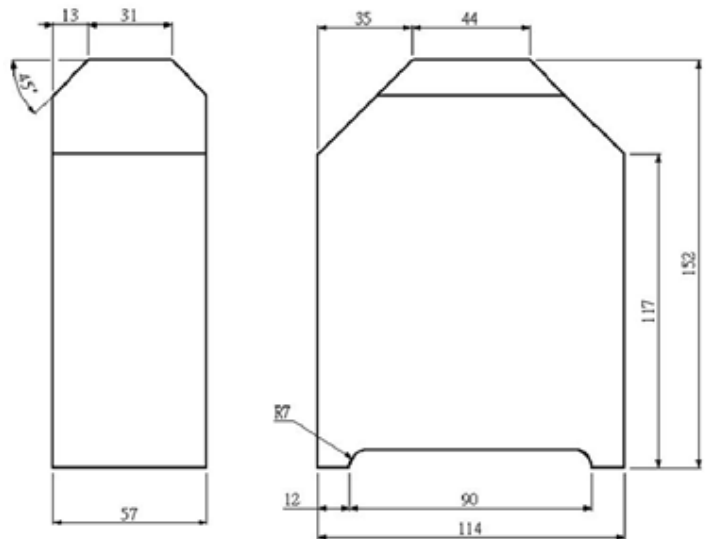

FIGURE 16: CUTTERHEAD

Anti-Kickback Fingers

⚠ WARNING

- TURN PLANER OFF AND DISCONNECT POWER BEFORE PERFORMING ANY MAINTENANCE OR ADJUSTMENTS!

Anti-kickback fingers help prevent stock from being kicked out of the machine towards the user. Keep the fingers clean and free from sawdust, pitch gum, etc., so they operate smoothly.

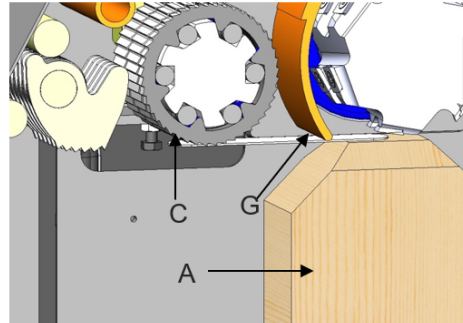

FIG. 17: FINGER ADJUSTMENT

Adjustment of Infeed Roller

⚠ WARNING

- TURN PLANER OFF AND DISCONNECT POWER BEFORE PERFORMING ANY MAINTENANCE OR ADJUSTMENTS!

The in-feed roller should be set 0.02" below the lowest point of knife. Make sure the knives are set properly see the "Setting / Changing Knives" section prior to making any adjustments.

1. Disconnect machine from power source.
1. Place a hard wood gauge (Fig.17, A) under a knife in cutterhead (Fig.17, B). Place a 0.02" feeler gauge (Fig.17, C) on top of wood block and raise table until feeler gauge contacts the knife in its lowest position.
2. Remove feeler gauge and place wood block under the left side of infeed roller (Fig.18, D). The top of wood gauge should just contact the infeed roller. If it doesn't, loosen jam nut (Fig. 18, E) and turn the adjusting screw (Fig.18, F) to raise, or lower the infeed roller until it contacts wood gauge then tighten the nut (E). Repeat for opposite side of the infeed roller.

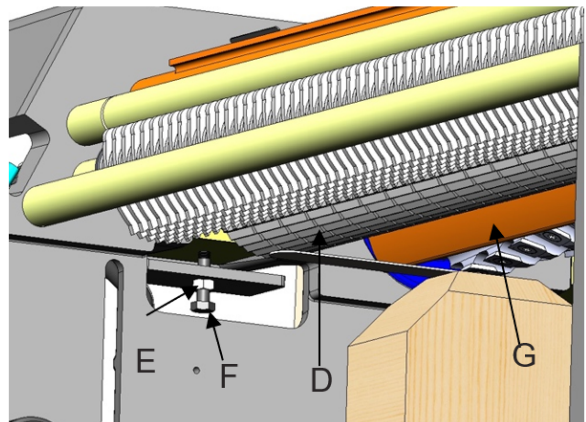

FIG. 18: INFEEED ROLLER ADJUSTMENT

Adjustment of Pressure Bar

⚠ WARNING

- TURN PLANER OFF AND DISCONNECT POWER BEFORE PERFORMING ANY MAINTENANCE OR ADJUSTMENTS!

The pressure bar should be set even with the lowest point of knife. Make sure the knives are set properly see the "Setting / Changing Knives" section prior to making any adjustments.

1. Disconnect machine from power source.
2. Loosen screw (Fig. 19, 1) and nut (Fig.19, 2) turn the screw to the right so that the pressure bar moves upward. Place gauge block and 0.2m thickness gauge (Fig.17, A) under the cutterhead.
3. Place gauge block under pressure bar.
4. Make pressure bar touch the top of the gauge block.
5. Finally, tighten the screw and replace the nut.

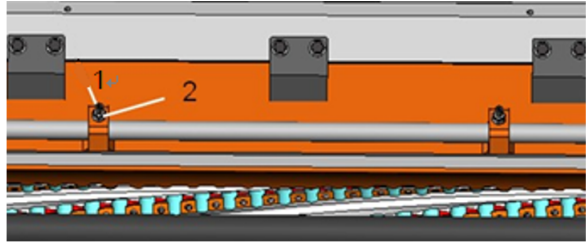

FIG. 19: PRESSURE BAR ADJUSTMENT

Adjustment of Out-feed Roller

⚠ WARNING

- TURN PLANER OFF AND DISCONNECT POWER BEFORE PERFORMING ANY MAINTENANCE OR ADJUSTMENTS!
- MAKE SURE ALL KNIFE INSERT SCREWS ARE TIGHTENED SECURELY. LOOSE INSERTS CAN BE PROPELLED AT HIGH SPEED FROM A ROTATING CUTTERHEAD, CAUSING INJURY.
 - TORQUE EACH SCREW TO 52-60 IN/LBS.
- KNIVES ARE EXTREMELY SHARP. BE VERY CAREFUL WHEN HANDLING KNIVES. FAILURE TO COMPLY MAY CAUSE SERIOUS INJURY

The out-feed roller should be set 0.02" below the lowest point of knife. Make sure the knives are set properly see the "Setting / Changing Knives" section prior to making any adjustments.

1. Disconnect machine from power source.
2. Place a hard wood gauge (Fig.17, A) under a knife in the cutterhead. Place a 0.02" feeler gauge (Fig. 17, B) on top of wood block and raise table until the gauge contacts the knife in its lowest position.
3. Remove feeler gauge and place wood block
4. (Fig.20, E) under the left side of outfeed roller (Fig. 20, F). The top of wood gauge should just contact the outfeed roller. If it doesn't, loosen jam nut (Fig. 21, H) and turn the adjusting screw (Fig. 21, G) to raise, or lower the out-feed roller until it contacts wood gauge.

The cutterhead is set-up with the same relationship to the infeed roller, pressure bar and outfeed roller. The planer comes set up from the factory and shouldn't need any adjustment.

If adjustment is necessary, follow the steps for setting the in-feed roller, chipbreaker, pressure bar and outfeed roller in relation to the helical cutterhead.

When it is time to rotate the knives ALL knives should be rotated at the same time. This is the same when replacing carbide knives ALL knives must be replaced at the same time. Mark the knives with a marker to identify which knives have been rotated. You can rotate the knives three times before replacing. Use a Torx wrench to rotate or remove knives. **Torque each knife screw to 52-60 in/lbs.**

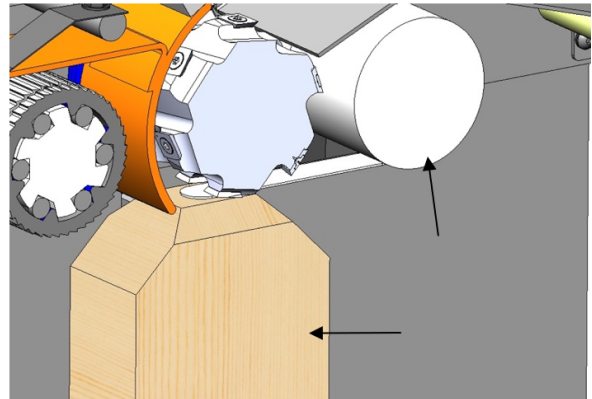

FIGURE 20: OUTFEED ROLLER ADJUSTMENT

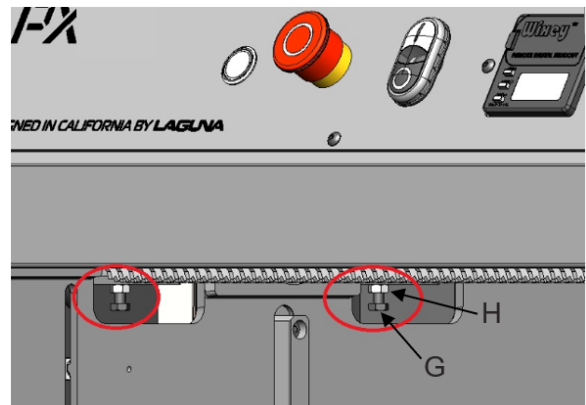

FIGURE 21: OUTFEED ROLLER ADJUSTMENT

Poly-V-Belt Adjustment

⚠ WARNING

- TURN PLANER OFF AND DISCONNECT POWER BEFORE PERFORMING ANY MAINTENANCE OR ADJUSTMENTS!

Poly-V-belt (Fig. 22, D) tension has been set at the factory. If the belt has stretched and needs adjustment.

1. Disconnect machine from power source.
2. Open lower rear, and lower left-hand side panels. Loosen and tighten four adjustment nuts (Fig. 22, D) to move motor plate up, or down to increase, or decrease belt tension.
3. Tighten nuts against motor plate after adjustment is made.
4. Belts are tensioned properly when moderate finger pressure can deflect the v-belts about a 1/4"-1/2" midway between the pulleys.

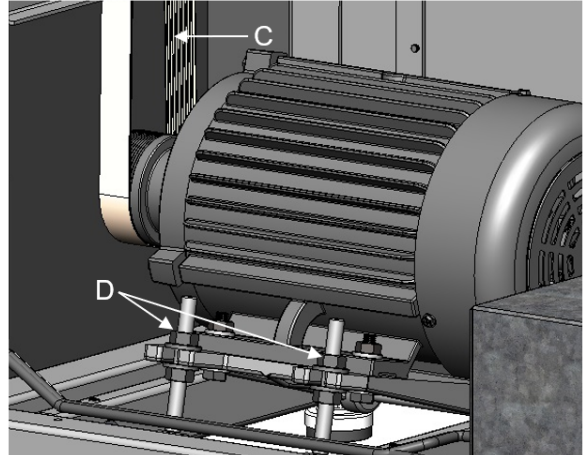

FIGURE 22: POLY-V-BELT ADJUSTMENT

Adjusting Table Rollers

⚠ WARNING

- TURN PLANER OFF AND DISCONNECT POWER BEFORE PERFORMING ANY MAINTENANCE OR ADJUSTMENTS!

The table rollers come pre-set from the factory and shouldn't need any adjustment. If adjustment is necessary, follow the below listed steps.

1. Lay a gauge or straight edge (Fig. 23, A) on the table across the roller (Fig. 23, B).
2. Raise the rollers until it contacts the straight edge and lock the handle. The pointer should be set at "0". If not adjust the pointer to read zero. Note: Spin the roller by hand to know when roller makes contact with the straight edge.
3. Move straight edge to the opposite side of bed roller and check to see that the roller just contacts straight edge. If not turn the knob (Fig. 24, C) under the table to raise or lower the bed roller until it just contacts the straight edge.

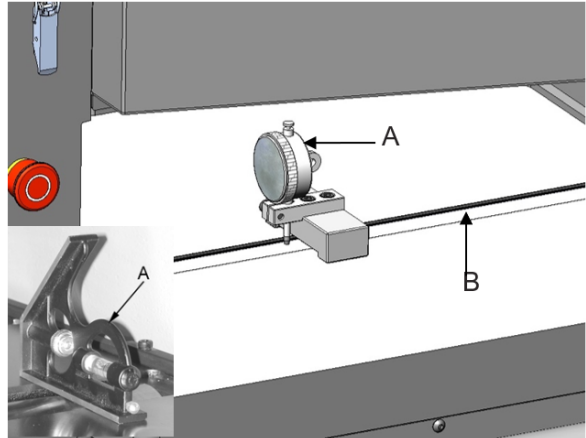

FIGURE 23: TABLE ROLLER ADJUSTMENT

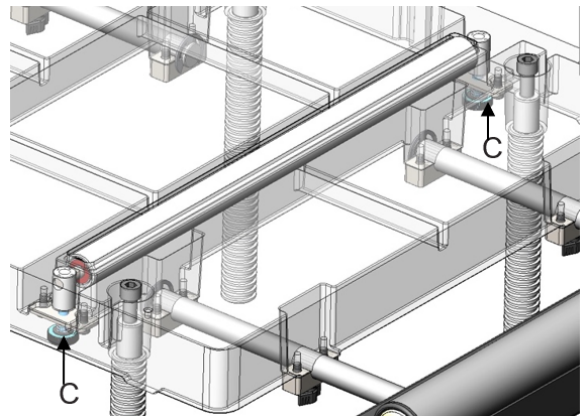

FIGURE 24: TABLE ROLLER ADJUSTMENT

Dust Collection

To ensure proper operation and longest knife life it is important to maintain full air flow to your dust collection system. Make sure the filter media is clean and there are no obstructions in the ducting.

Lubrication

Regular monitoring and replacement of lubrication is needed.

Figure 25 Table

NO.	POSITION	GREASE	OIL
1	GEAR BOX	NO	YES
2	CHAIN	YES	NO
3	CHAIN	YES	NO
4	CHAIN	YES	NO
5	CHAIN	YES	NO
6	BUSHING	NO	YES
7	LEAD SCREW	YES	NO

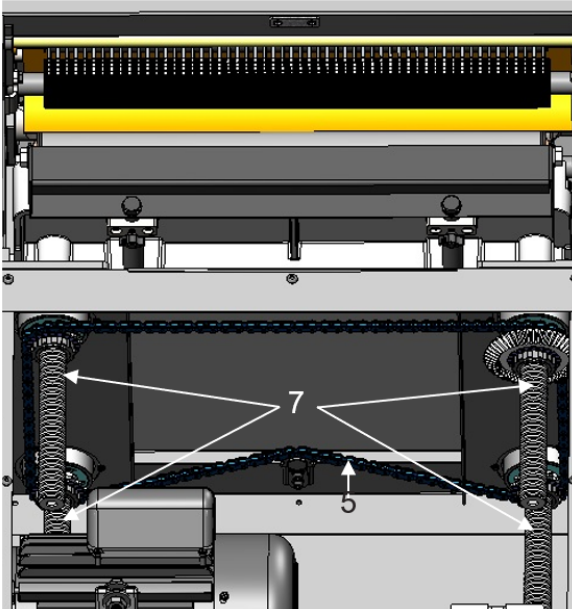

FIGURE 26: LUBRICATION

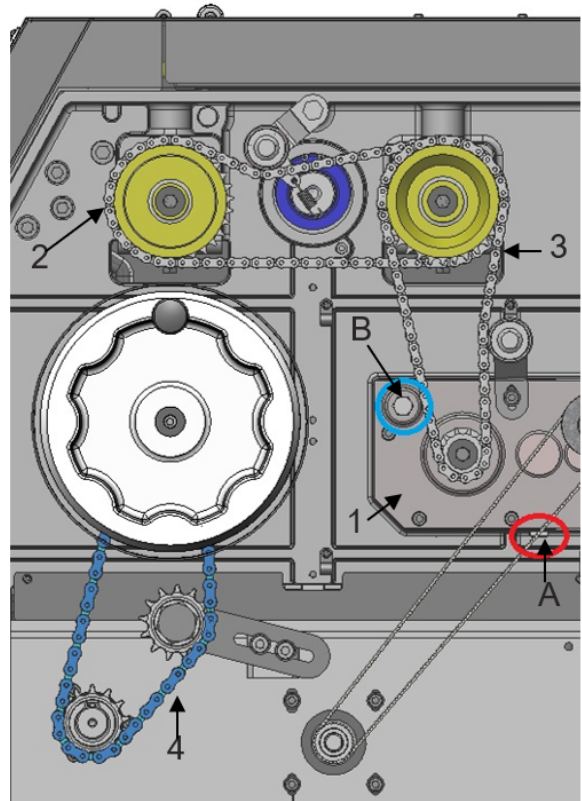

FIGURE 25: LUBRICATION

- The Gear Box oil must be changed after 2500 hours of work. (Fig. 25)
- All chains must be lubricated regularly. (Fig. 25 & 26)
- Every 30 hours, lubricate the bushings. (Fig. 27)
- Lubricate the four lead screws regularly. (Fig. 26).
- Teflon Lube is the preferred lubrication for the lead screws.

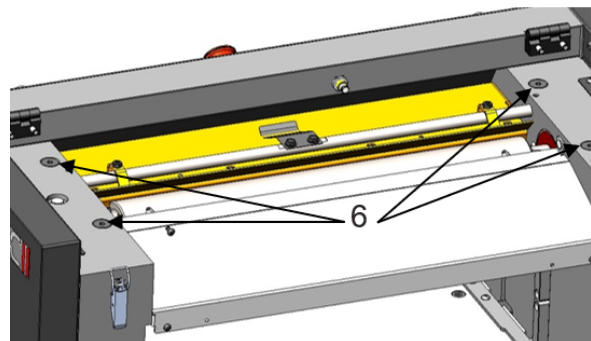

FIGURE 27: LUBRICATION

Troubleshooting

Symptom	Possible Cause	Possible Solution
Machine will not start	<ol style="list-style-type: none"> 1. Fuse blown or circuit breaker tripped 2. Cord damaged 3. Not connected to power source 4. Connected to wrong voltage 5. Top cover is open 6. Emergency stop button pressed 7. Overload tripped 	<ol style="list-style-type: none"> 1. Replace fuse or reset circuit breaker 2. Have cord replaced 3. Check connection 4. Check voltage 5. Close top cover 6. Rotate emergency stop button clockwise until it pops out 7. Remove lower rear cover on the base and press reset switch found inside
Cutterhead does not come up to speed	<ol style="list-style-type: none"> 1. Low current 2. Motor not connected to correct voltage 	<ol style="list-style-type: none"> 1. Contact local electric company 2. Refer to motor nameplate for correct voltage
Workpiece stops when feeding	<ol style="list-style-type: none"> 1. Too much material being removed in one pass 2. Chipbreaker or pressure bar set too low 3. Insufficient pressure on in-feed or out-feed rollers 	<ol style="list-style-type: none"> 1. Reduce the amount of material being removed 2. Raise the pressure 3. Increase pressure on in-feed or out-feed rollers
Snipe	<ol style="list-style-type: none"> 1. 1. Incorrect setting for infeed, out-feed rollers, pressure bar 2. Inadequate support of long boards 3. Table roller not set properly 	<ol style="list-style-type: none"> 1. Adjust feed system 2. Support long boards with extension rollers 3. Adjust table roller until desired results are achieved.
Fuzzy Grain	<ol style="list-style-type: none"> 1. Planing wood with a high moisture content 2. Dull knives 	<ol style="list-style-type: none"> 1. Allow wood to dry properly 2. Rotate or replace knives.
Poor feeding of lumber	<ol style="list-style-type: none"> 1. Inadequate feed roll pressure 2. Planer bed dirty 3. Drive-belt(s) slipping 4. Dirty feed rollers 5. Incorrect setting for in-feed, out-feed rollers, pressure bar 	<ol style="list-style-type: none"> 1. Adjust feed roll tension or lower feed rollers 2. Clean pitch and residue off table with a non-flammable solvent 3. Increase drive-belt tension 4. Clean feed rollers with a non-flammable solvent 5. Adjust feed system

Wiring

⚠ WARNING

REVIEW [ELECTRICAL SAFETY](#) PRIOR TO ANY WIRING PROCEDURES.

MPLANPX20-0130

VOLTAGE	220V
PHASE	1PH
HERTZ	60Hz
FULL LOAD AMPERAGE	23 AMPS

⚠ WARNING! Below are RECOMMENDATIONS to be used for this machine based on the above information. Variables that may affect this are:

- Actual voltage supplied to the machine
- Electrical code that must be met in your local province.

An electrician will verify that all the demands are met to properly wire the machine. If you have absolutely any doubt when wiring this machine - please consult with a qualified electrician.

PLUG/RECEPTACLE	Not Included
WIRING (Gauge)	See Jacket Printing
CIRCUIT BREAKER	30 Amp Minimum

PX20 5HP*220V-240V*60HZ*1PH*2P

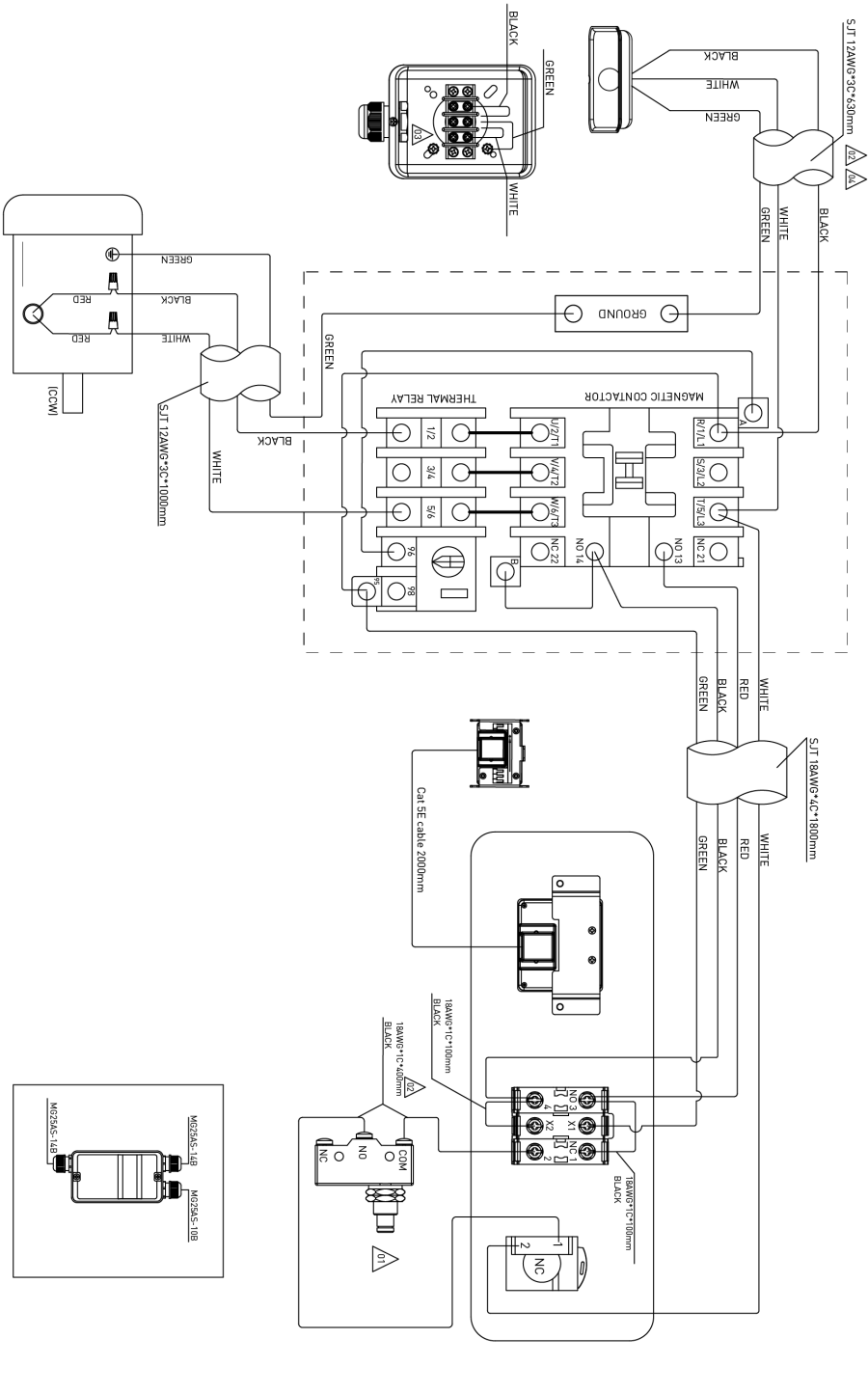

Replacement Parts Diagram

Base

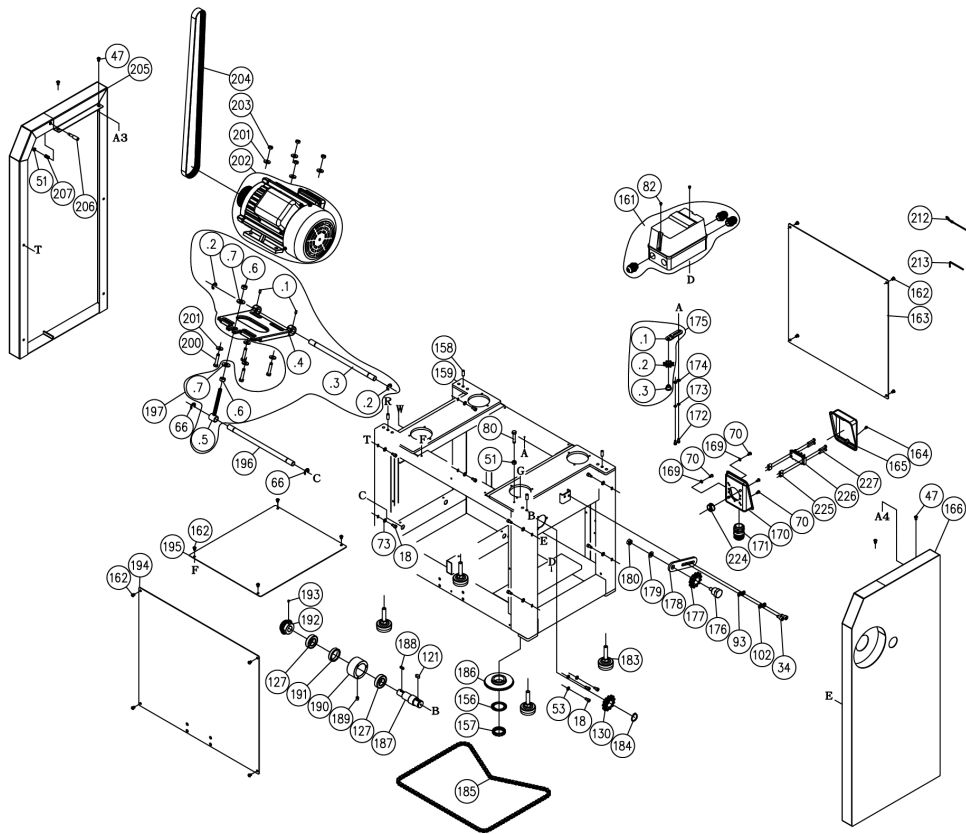

Table

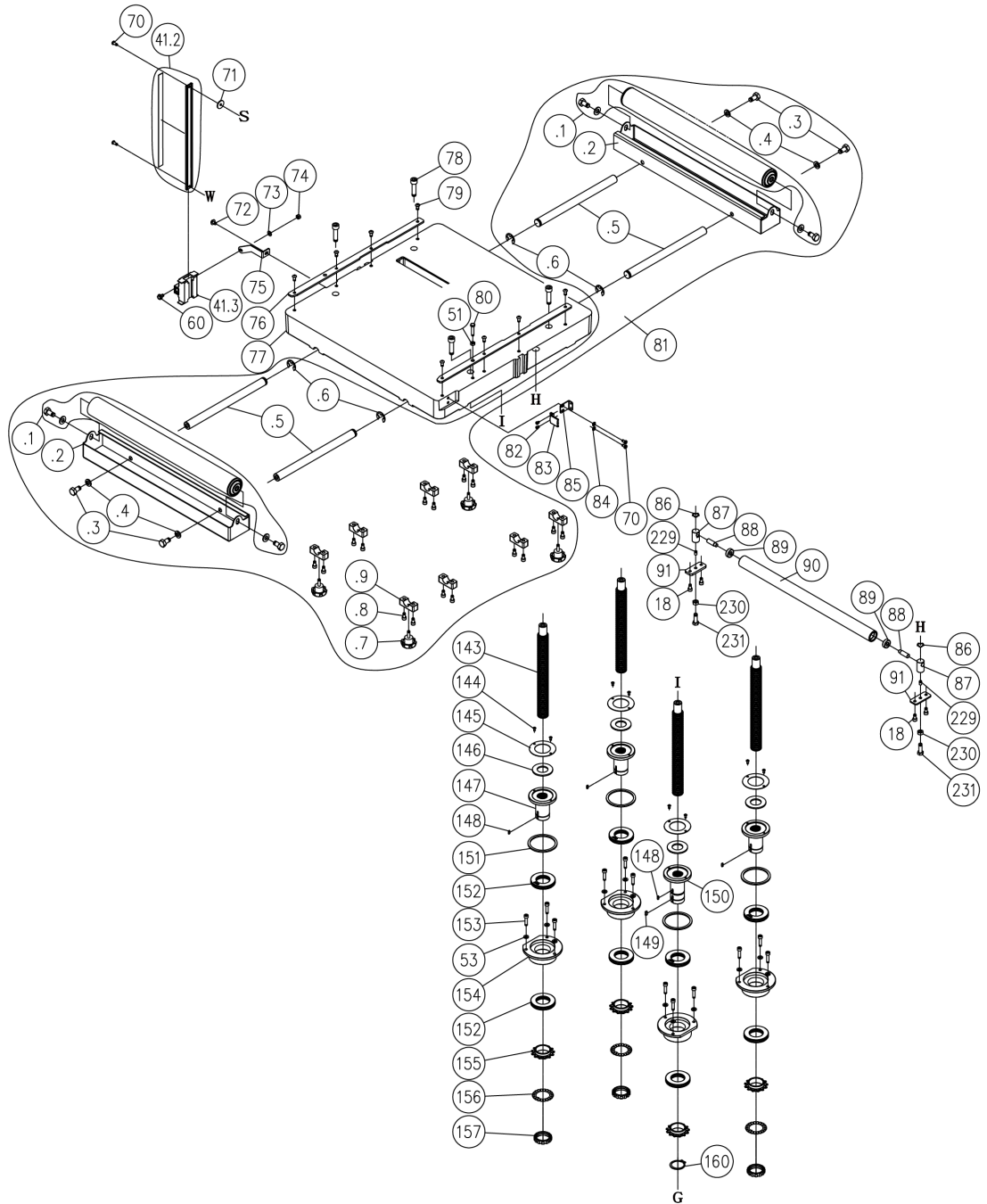

Cutter Assembly

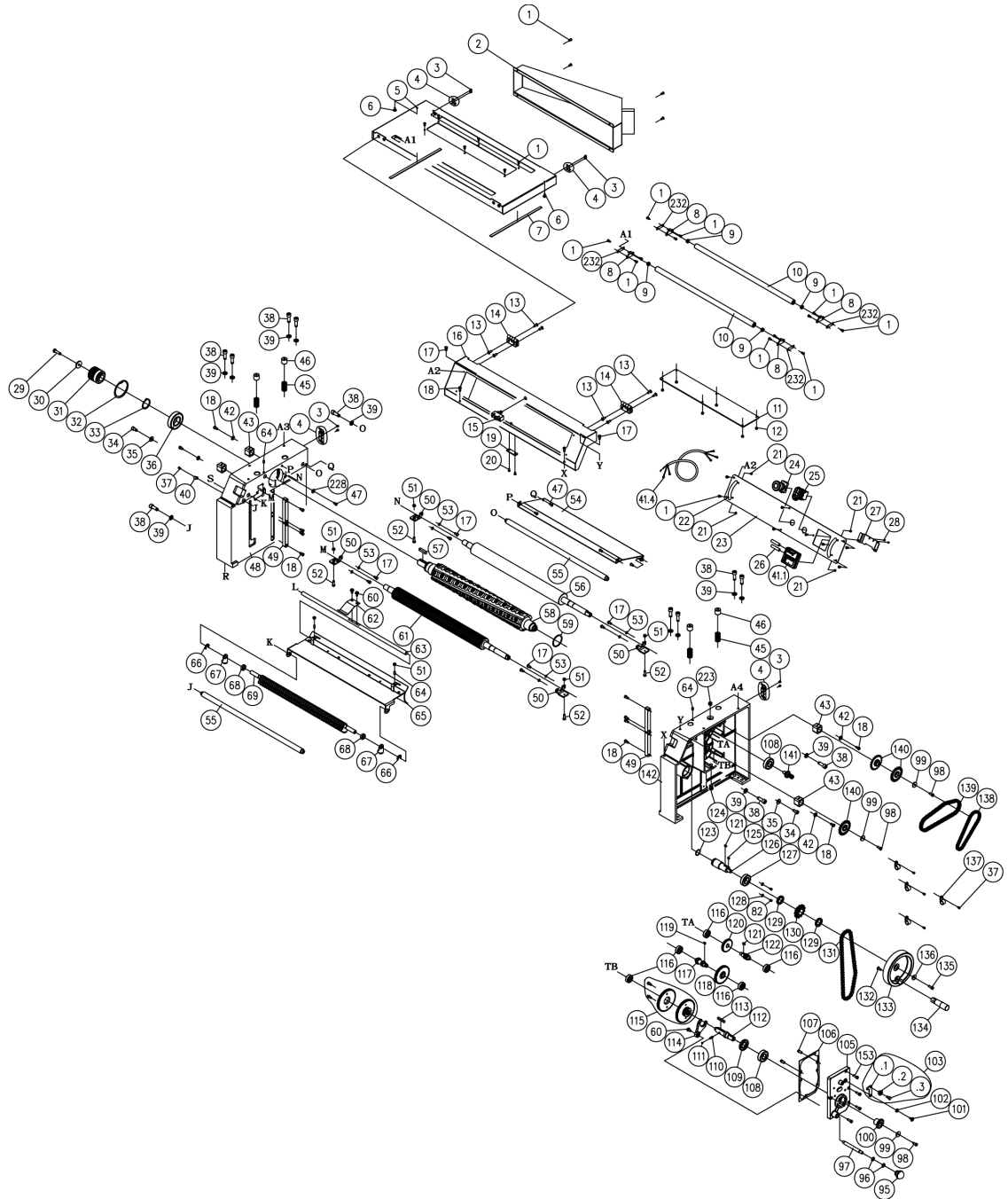

Replacement Parts Table

REF NO	PART NUMBER	DESCRIPTION	SPECIFICATION	QTY
1	000804-107	ROUND HEAD HEX SCREW	M5*0.8P*12	30
2	174833-000	DUST CHUTE		1
3	000302-201	ROUND HEAD PHILLIPS SCREW	M4*0.7P*6	8
4	230409-905	BUCKLE	CT-22	2
5	174832-000	TOP COVER		1
6	340007-615	BLOCK		2
7	200113-615	SPONGE		2
8	174723-904	ROLLER BRACKET		4
9	030119-000	BALL BEARING	605	4
10	361392-906	ROLLER		2
11	251317-620	PC BOARD		1
12	008302-100	HEX. LOCK NUT	M5*0.8P/(8B*6H)	6
13	000403-207	FLAT HEAD PHILLIPS SCREW	M6*1.0P*16	8
14	679030-008	BUTTERFLY HINGE		2
15	491101-000	LIMITED SWITCH	MJ2-1307	1
16	174831-000	CONTROL BOX COVER		1
17	000002-101	HEX. SCREW	M6*1.0P*12	10
18	000103-103	CAP SCREW	M6*1.0P*12	29
19	174828-000	LIMIT PLATE		1
20	002102-201	FLAT HEAD PHILLIPS LOCK SCREW	M4*0.7P*10L	2
21	000301-101	ROUND HEAD PHILLIPS SCREW	M3*0.5P*6	4
22	300117-909	HANDLE		2
24	491153-000	EMERGENCY STOP	NPB22-H01R	1
25	491127-000	POWER SWITCH	M22DP-SF11E230WB(I,0)	1
26	490488-000	BATTERY	AAA	2
27	174750-000	FIXING PLATE		1
28	001202-602	SLET-TAPPING SCREW	M3*1.06P*6	2
29	048201-101	HEX. LOCK NUT	M8*1.25P*20	1
30	006001-043	FLAT WASHER	8.2*30*4.0T	1
31	381423-902	CUTTERHEAD PULLEY	60HZ	1
32	010121-000	RETAINING RING	RTW-80	1
33	010025-000	RETAINING RING	STW-40	1
34	000104-104	CAP SCREW	M8*1.25P*16	4
35	006001-054	FLAT WASHER	8.5*20*2.0T	2
36	030223-002	BALL BEARING	6208	1
37	000302-102	ROUND HEAD PHILLIPS SCREW	M4*0.7P*8	5
38	000105-102	CAP SCREW	M10*1.5P*25	12
39	006307-300	SPRING WASHER	10.2*18.5	12
40	021107-100	WIRE FIXING BUCKLE	ACC-1.5-B	1

REF NO	PART NUMBER	DESCRIPTION	SPECIFICATION	QTY
41	924681-000	DIGITAL READ OUT ASSEMBLY	WIXEY MODEL WR5502CT	1
42	006001-034	FLAT WASHER	6.7*16*2.0T	4
43	130384-000	BUSHING		4
45	280276-000	SPRING		4
46	380200-901	SCREW		4
47	000801-202	ROUND HEAD HEX SCREW	M6*1.0P*12	9
48	051446-000	COLUMN-L		1
49	381405-902	FIXING PLATE		4
50	174825-904	ADJUSTABLE PLATE		4
51	008005-100	HEX. NUT	M6*1.0P(10B*5H)	9
52	000002-104	HEX. SCREW	M6*1.0P*20	4
53	006303-100	SPRING WASHER	6.5*10.5	23
54	174830-000	CHIP GUIDE		1
55	361391-902	ROD		2
56	361417-000	OUTFEED ROLLER		1
57	012006-001	KEY	8*8*40	1
58	925091-000	HELICAL CUTTERHEAD ASSY	SHEAR-TEC	1
	038201-702	TORX SCREW	#10-32UNF*12.5	138
	210114-000	KNIFE	15*15*2.5T	138
	040703-000	TROX WRENCH	T-25	2
59	043343-000	RETAINING RING	NBR/46.3*3.1	1
60	000902-102	HEX. SCREW W/WASHER	M6*1.0P*12	4
61	361430-000	INFEED ROLLER ASSEMBLY		1
62	270015-901	SPRING PLATE		1
63	361389-902	SUPPORT ROD		1
64	000203-104	SET SCREW	M6*1.0P*12	4
65	174837-156	FRONT CHIP GUIDE		1
66	010208-000	RETAINING RING	ETW-12	4
67	174722-905	ANTI-KICK-BACK FINGER		56
68	250060-615	SPACER		57
69	361390-902	ANTI-KICK-BACK SHAFT		1
70	000303-104	ROUND HEAD PHILLIPS SCREW	M5*0.8P*12	8
71	006001-127	FLAT WASHER	5.5*22*2.0T	1
72	001603-102	ROUND HEAD PHILLIPS SCREW W/FLAT WASHER	M6*1.0P*10/6*13.2*1.0T	1
73	006001-032	FLAT WASHER	6.6*13*1.0T	9
74	008304-100	HEX. LOCK NUT	M6*1.0P(10B*7H)	1
75	174827-000	BRACKET		1
76	174826-000	GUIDE PLATE		2
77	051449-000	TABLE		1
78	002604-103	CAP LOCKING SCREW	M10*1.5P*40	4
79	000801-102	ROUND HEAD HEX SCREW	M6*1.0P*12	8

REF NO	PART NUMBER	DESCRIPTION	SPECIFICATION	QTY
80	000002-106	HEX. SCREW	M6*1.0P*30	2
81	924841-000	EXTENSION ROLLER ASSEMBLY		1
.1	660301-000	ROLLER		2
.2	174838-904	ROLLER BRACKET		2
.3	000004-101	HEX. SCREW	M10*1.5P*20	4
.4	006307-100	SPRING WASHER	10.2*18.5	4
.5	361386-902	EXTENSION ROD		4
.6	010202-000	RETAINING RING	ETW-17	4
.7	230131-000	FIXING BOLT		4
.8	000103-103	CAP SCREW	M6*1.0P*12	16
.9	130395-903	BUSHING		8
82	000302-701	ROUND HEAD PHILLIPS SCREW	M4*0.7P*6	6
83	250463-620	POINTOR		1
84	006001-009	FLAT WASHER	5.2*10*1.0T	2
85	174561-000	POINTOR FIXING PLATE		1
86	006704-100	WAVES WASHER	WW-12	2
87	361365-902	GUIDE BLOCK		2
88	361384-902	ROLLER SHAFT		2
89	030005-001	BALL BEARING	608	2
90	190308-000	ROLLER		1
91	174763-904	ADJUSTABLE PLATE		2
93	006001-045	FLAT WASHER	8.5*16*1.0T	2
95	250372-615	KNOB		1
96	043303-000	RETAINING RING	P12	2
97	360358-901	SHAFT		1
98	000002-203	HEX. SCREW	M6*1.0P*16	3
99	006001-021	FLAT WASHER	6.2*22*3T	3
100	150008-000	CHAIN SPROCKET		1
101	290104-902	SHOULDER SCREW		1
102	006305-100	SPRING WASHER	8.2*13.7	3
103	924699-000	IDLER ASSEMBLY		1
.1	174685-902	BRACKET		1
.2	130095-000	CHAIN TENSIONER		1
.3	360561-902	CHAIN TENSIONER SHAFT		1
105	090358-000	GEARBOX COVER		1
106	340012-615	GEARBOX GASKET		1
107	360355-901	PIN		2
108	030208-002	BALL BEARING	6204	2
109	043505-000	OIL SEAL	SC25*47*6	1
110	280052-000	SPRING		1
111	017002-000	STEEL BALL	ψ6	1
112	360357-000	SHAFT		1

REF NO	PART NUMBER	DESCRIPTION	SPECIFICATION	QTY
113	012004-003	KEY	6*6*40	1
114	130404-000	SHIFTING CLAW		1
115	924811-000	GEAR ASSEMBLY		1
116	030205-002	BALL BEARING	6201	5
117	320356-000	SHAFT		1
118	320198-000	GEAR		1
119	012003-002	KEY	5*5*10	1
120	320406-000	GEAR	52T	1
121	012003-003	KEY	5*5*12	3
122	320160-000	SHAFT		1
123	043337-000	O-RING	P22	1
124	043401-000	PLUG	PT1/4"-19	1
125	012002-011	KEY	4*4*15	1
126	361383-902	HANDWHEEL ASSEMBLY		1
127	030104-001	BALL BEARING	6005	3
128	006001-003	FLAT WASHER	4.3*12*1.0T	2
129	174700-902	SPACER		2
130	380259-000	SPROCKET		2
131	016019-000	CHAIN	#40*42P	1
132	000702-104	FLAT HEAD HEX. SCREW	M6*1.0P*16	1
133	240092-000	HAND WHEEL		1
134	230284-000	FOLDING HANDLE	HL-65	1
135	000103-105	CAP SCREW	M6*1.0P*15	1
136	006001-026	FLAT WASHER	6.4*20*3.0T	1
137	021103-100	WIRE FIXING BUCKLE	ACC-3-B	4
138	016322-000	CHAIN	#06B*42P	1
139	016311-000	CHAIN	#06B*54P	1
140	150029-000	CHAIN SPROCKET		3
141	320405-000	GEAR		1
142	051447-000	COLUMN-R		1
143	361314-902	LIFTING LEAD SCREW		4
144	000805-705	ROUND HEAD HEX SCREW	M4*0.7P*8	8
145	175016-902	PRESSURE PLATE		4
146	660289-000	PAKING		4
147	051416-902	LEAD SCREW SEAT		3
148	012001-003	KEY	3*3*10	4
149	012002-005	KEY	4*4*12	1
150	051415-902	MAIN LEAD SCREW SEAT		1
151	660290-000	PACKING		4
152	920133-000	THRUST BEARING		8
153	000103-107	CAP SCREW	M6*1.0P*20	17
154	381404-902	BEARING HOUSING - TOP		4

REF NO	PART NUMBER	DESCRIPTION	SPECIFICATION	QTY
155	150016-000	LIFTING SPROCKET		4
156	170746-901	TEETH WASHER		4
157	130094-903	LOCK NUT		4
158	360413-901	FIXING PIN		4
159	174836-000	BASE CASTING		1
160	010014-000	RETAINING RING	STW-35	1
161	938011-000	MAGNETIC SWITCH ASSEMBLY	5HP*220V-240V*1PH*CSA	1
162	000801-108	ROUND HEAD HEX SCREW	M6*1.0P*8	12
163	174845-000	BASE REAR COVER		1
164	003303-102	ROUND HEAD PHILLIPS SCREW	3/16"-24NC*1/4"	1
165	490124-000	TERMNAL COVER		1
166	174820-000	SIDE COVER - R		1
169	006502-100	TEETH WASHER	5.3*10(BW-5)	2
170	491116-000	CONNECT BOX		1
171	023701-007	STRAIN RELIEF	MG25AS-14B	1
172	000102-103	CAP SCREW	M5*0.8P*10	2
173	006302-300	SPRING WASHER	5.1*9.3	2
174	006001-012	FLAT WASHER	5.3*12*1.0T	2
175	920135-000	TENSION WHEEL ASSEMBLY		1
.1	170759-902	BRACKET		1
.2	250072-615	CHAIN SPROCKET		1
.3	360247-901	CHAIN TENSIONER SHAFT		1
176	290040-901	IDLER SHAFT		1
177	150001-000	IDLER		1
178	170413-901	CHAIN TENSIONER BRACKET		1
179	006006-120	FLAT WASHER	20*10.2±0.1*2±0.1	1
180	008007-100	HEX. NUT	M10*1.5P(17B*8H)	1
183	230403-000	FEET		4
184	010011-000	RETAINING RING	STW-25	1
185	016229-000	CHAIN	Z410*136P	1
186	320403-000	BEVEL GEAR		1
187	361312-902	LIFTING SHAFT		1
188	012003-004	KEY	5*5*15	1
189	000204-102	SET SCREW	M8*1.25P*10	1
190	381402-902	BEARING HOUSING		1
191	381403-902	SPACER		1
192	320207-000	BEVEL GEAR		1
193	000202-102	SET SCREW	M5*0.8P*8	1
194	174834-000	BASE FRONT COVER		1
195	174835-000	BASE TOP COVER		1
196	361385-902	SUPPORT ROD		1
197	925023-000	MOTOR MOUNTING ASSEMBLY		1

REF NO	PART NUMBER	DESCRIPTION	SPECIFICATION	QTY
.1	000203-104	SET SCREW	M6*1.0P*12	2
.2	010208-000	RETAINING RING	ETW-12	2
.3	361385-902	SUPPORT ROD		1
.4	050287-008	MOTOR PLATE		1
.5	380148-000	ADJUSTABLE ROD		1
.6	008007-100	HEX. NUT	M10*1.5P(17B*8H)	2
.7	006003-091	FLAT WASHER	13*28*3.0T	2
200	000003-108	HEX. SCREW	M8*1.25P*40	4
201	006001-041	FLAT WASHER	8.2*22*3.0T	8
202	960007-000	MOTOR ASSEMBLY	5HP*220- 240V*60HZ*1PH*2P	1
203	008006-800	HEX. NUT	M8*1.25P(13B*6.5H)	4
204	014371-000	POLY-V-BELT	560J-12	1
205	174823-000	SIDE COVER - L		1
206	360579-902	SUPPORT PIN		1
207	280089-901	SPRING		1
208	471037-084	CONNECT CORD	18AWG*1C*100BLACK	1
209	471037-085	CONNECT CORD	18AWG*1C*100BLACK	1
210	471037-091	CONNECT CORD	18AWG*1C*400BLACK	1
211	471037-111	CONNECT CORD	18AWG*1C*400BLACK	1
212	230297-615	CORD FIXED CHAIN		4
213	040003-000	HEX. WRENCH	3*63MM	1
223	043406-000	PLUG	PT1/4"-19	1
224	021803-000	BUCKLE	NB-1925	1
225	250573-615	BUSHING		4
226	490336-000	TERMINAL BLOCK		1
227	000303-110	ROUND HEAD PHILLIPS SCREW	M5*0.8P*30	4
228	006003-114	FLAT WASHER	6.4*16*1.6T	1
229	001902-101	SET LOCK SCREW	M6*1.0P*10	2
230	008006-100	HEX. NUT	M8*1.25P(13B*6.5H)	2
231	000003-105	HEX. SCREW	M8*1.25P*25	2
232	175019-000	PACKING		4

Warranty

This machine is covered by a warranty and the purchasing dealer can answer any questions you may have. Additionally, you can contact Laguna: +1 (949) 474-1200 customerservice@lagunatools.com.

Every product sold is warranted to be free of manufacturers' defective workmanship, parts, and materials. For any questions about this product, the intended use or what it was designed for, customer service, or replacement parts – please reach out to our customer service department.

REGISTRATION

TO PREVENT VOIDING THIS WARRANTY, ALL PRODUCTS SOLD MUST BE REGISTERED WITHIN THIRTY (30) DAYS OF RECEIVING. REGISTERING THE PRODUCT WILL ENABLE THE ORIGINAL PURCHASER TO RECEIVE NOTIFICATIONS ABOUT IMPORTANT PRODUCT CHANGES AND RECEIVE CUSTOMER SUPPORT.

[HTTPS://LAGUNATOOLS.COM/POLICIES/WARRANTY/](https://lagunatools.com/policies/warranty/)

WHAT IS COVERED?

ANY PART, DETERMINED BY LAGUNA TOOLS®, TO HAVE A DEFECT WILL BE REPAIRED OR REPLACED (AND SHIPPED), WITHOUT CHARGE. IT IS REQUIRED THAT THE DEFECTIVE ITEM/PART BE RETURNED TO LAGUNA TOOLS® WITH THE COMPLAINT AND PROOF OF PURCHASE IN THE ORIGINAL PACKAGING THAT IT WAS RECEIVED. IN THE EVENT THE ITEM/PART IS DETERMINED TO BE VOID OF THIS WARRANTY, THE CUSTOMER WILL BE RESPONSIBLE FOR THE COST TO REPLACE THE ITEM/PART AND ALL RELATED SHIPPING CHARGES.

WHO IS COVERED?

THE APPLICABLE WARRANTY COVERS ONLY THE INITIAL PURCHASER OF THE PRODUCT FROM THE RECEIPT DATE. THE ORIGINAL PURCHASER MUST PRESENT THE ORIGINAL RECEIPT AS PROOF OF PURCHASE.

SHIPPING DAMAGE

LAGUNA TOOLS® AND THE PURCHASING CUSTOMER IS NOT RESPONSIBLE FOR DAMAGE OR LOSS CAUSED BY A FREIGHT COMPANY OR OTHER CIRCUMSTANCES NOT IN THE DIRECT CONTROL OF LAGUNA TOOLS®. ALL SHIPPING RELATED CLAIMS FOR LOSS OR DAMAGED GOODS MUST BE MADE TO LAGUNA TOOLS WITHIN TWENTY-FOUR HOURS OF DELIVERY.

WARRANTY LIMITATIONS

THIS LIMITED WARRANTY DOES NOT APPLY TO NATURAL DISASTERS, ACTS OF TERRORISM, NORMAL WEAR AND TEAR, PRODUCT FAILURE DUE TO LACK OF MAINTENANCE OR CLEANING, DAMAGE CAUSED BY ACCIDENT, NEGLIGENCE, OR LACK-OF/INADEQUATE DUST COLLECTION. THE WARRANTY MAY BE VOIDED AGAINST PROOF OF MISUSE/ABUSE, DAMAGE CAUSED WHERE REPAIR OR ALTERATIONS HAVE BEEN MADE OR ATTEMPTED BY OTHERS, USING THE PRODUCT FOR PURPOSES OTHER THAN THOSE DESCRIBED AS INTENDED USE (UNLESS WITH CONSENT BY LAGUNA TOOLS®), MODIFICATION TO THE PRODUCT, OR USE WITH AN ACCESSORY THAT WAS NOT DESIGNED FOR THE PRODUCT. IT IS THE RESPONSIBILITY OF THE USER TO UNDERSTAND BASIC WOODWORKING MACHINERY SETTINGS AND PROCEDURES AND TO PROPERLY MAINTAIN THE EQUIPMENT IN ACCORDANCE WITH THE STANDARDS PROVIDED IN THIS MANUAL.

LENGTH OF WARRANTY

ASIDE FROM BEING FREE OF DEFECTS UPON RECEIVING, CONSUMABLE PARTS, LIKE CUTTERS AND ABRASIVES, ARE NOT COVERED BY THIS WARRANTY UNLESS OTHERWISE STATED BY LAGUNA TOOLS®. THESE PARTS ARE DESIGNED TO BE USED AT THE EXPENSE OF THE OPERATOR AND ARE AVAILABLE FOR REPLACEMENT OR INVENTORY PURCHASE.

2 YEAR – NEW PURCHASES THROUGH AUTHORIZED DEALERS.

1 YEAR – NEW PURCHASES DIRECTLY FROM LAGUNA TOOLS.

1 YEAR – BLADES AND ACCESSORIES



LAGUNA AMERICAN HEADQUARTERS

Texas: 744 Refuge Way Suite 200, Grand Prairie, Texas 75050, U.S.A. Phone: +1-800-332-4094
Huntington Beach: 7291 Heil Ave Huntington Beach, CA 92647, U.S.A. Phone: +1-949-474-1200
South Carolina: 825 Bistline Dr. Ste 101, West Columbia, SC 29172, U.S.A. Phone: +1-800-234-1976
Minnesota: 5250 West 74th St, Edina, MN 55439, U.S.A Phone: +1-949-474-1200

DAKE CORPORATION

724 Robbins Road, Grand Haven, MI 49417, United States +1-800-937-3253

LAGUNA EUROPE

Walker Rd, Bardon Hill, Coalville LE67 1TU, United Kingdom. Phone: +44-1530-516921

© 2021 Laguna Tools