

ELTROPLAN-REVCON

Elektrotechnische Anlagen GmbH

Operating instructions



Power feed- feedback unit REVCON[®] RFE

Power range 30- ... 250 kW
Voltage range 400V, 460V, 500V

1	Preface and general information	3
1.1	Ordering code.....	4
1.2	Scope of delivery	4
1.3	Legal regulations.....	5
1.4	EC-Directives / Declaration of conformity	6
1.4.1	EC-Low-Voltage Directive.....	6
1.4.2	EC-directive Electromagnetic compatibility.....	8
1.4.3	EC-Directive Machinery	9
2	Safety information.....	10
2.1	General safety information.....	11
2.2	Safety-responsible persons.....	15
2.3	Layout of the safety information	16
2.4	Residual hazards.....	16
2.5	General instructions	17
3	Technical data	29
3.1	Characteristics	29
3.2	General data / application conditions.....	30
3.3	Rated data	31
3.3.1	Power feed - and feedback unit REVCON RFE B2/D2.....	31
3.3.2	Power feed- and feedback unit REVCON RFE B3/D3.....	32
3.4	Ampacity	33
3.4.1	REVCON RFE B2/D2.....	33
3.4.2	Dimensioning REVCON RFE B2/D2	35
3.5	REVCON RFE B3/D3.....	38
3.5.1	Dimensioning REVCON RFE B3/D3	40
3.6	Fuses and wire cross sections	43
3.6.1	Series fuses REVCON RFE B2/D2	43
3.6.2	Series fuses REVCON RFE B3/D3	44
3.7	Internal fuses.....	45
3.8	Switch on current limiter RFE B2/D2.....	48
3.9	DC-bus capacitors	49
3.10	RFI-filter	50
3.10.1	RFI-filter REVCON RFE B2/D2	50
3.10.2	RFI- filter REVCON RFE B3/D3	51
3.11	RHF-RA- Module	52
4	Installation	54
4.1	Mechanical installation.....	54
4.2	Dimensions.....	55
4.3	RHF-Module	61
4.4	RFI-filter	66

Contents

5	Electrical installation	70
5.1	Operator's safety	70
5.2	Protection of the power feed/feedback unit.....	70
5.3	Mains types / Mains characteristics	71
5.4	Specifications of the used wires.....	71
5.5	Connection	72
5.5.1	Terminals and connection instructions	73
5.6	Wiring schematic REVCON RFE B2/D2.....	75
5.7	Wiring schematic REVCON RFE B3/D3.....	77
5.8	Wiring schematic REVCON RFE B2/D2 with RHF-RA Module	79
5.9	Wiring schematic REVCON RFE B3/D3 with RHF-RA Module	81
6	Control wires	83
6.1	Control functions	83
6.2	Control wires REVCON RFE B3/D3 and REVCON RFE B2/D2.....	85
6.3	Installation of a power feed/feedback unit in a CE-typical drivesystem .	87
7	Installation	89
7.1	Connection of a RFI-filter	90
7.2	Design of an EMC-conformal cabinet	91
7.3	Installation of control wires.....	93
8	Commissioning	94
8.1	First powering up.....	94
8.2	Configuration.....	95
9	Troubleshooting and fault elimination.....	98
9.1	LED-messages	99
10	Service.....	101
11	Appendix	102
11.1	Options.....	102
12	REVCON® Product overview	105
13	Contact	106

1 Preface and general information

About these Operating Instructions

- These Operating Instructions help you to work properly on and with the power feed/feedback units REVCON® RFE. They contain safety information which must be observed and information which are necessary for an undisturbed operation of the units together with the exploitation of all the advantages of the system.
- All persons who work on and with the power feed/feedback units REVCON® RFE must have the Operation instructions available and observe all relevant notes and instruction.
- The Operating Instructions must always be in a complete and perfectly readable state.

Terminology used

Power feed/feedback unit

For „Power feed/feedback unit REVCON® RFE“ in the following the term „Power feed/feedback unit“ is used.

Controller

For the frequency inverter which is used together with the power feed/feedback unit in the following the term „Controller“ is used.

Drive system

For a drive system with power feed/feedback units, controller and other components of the drive system in the following the term „Drive system“ is used.

Preface and general information

1.1 Ordering code

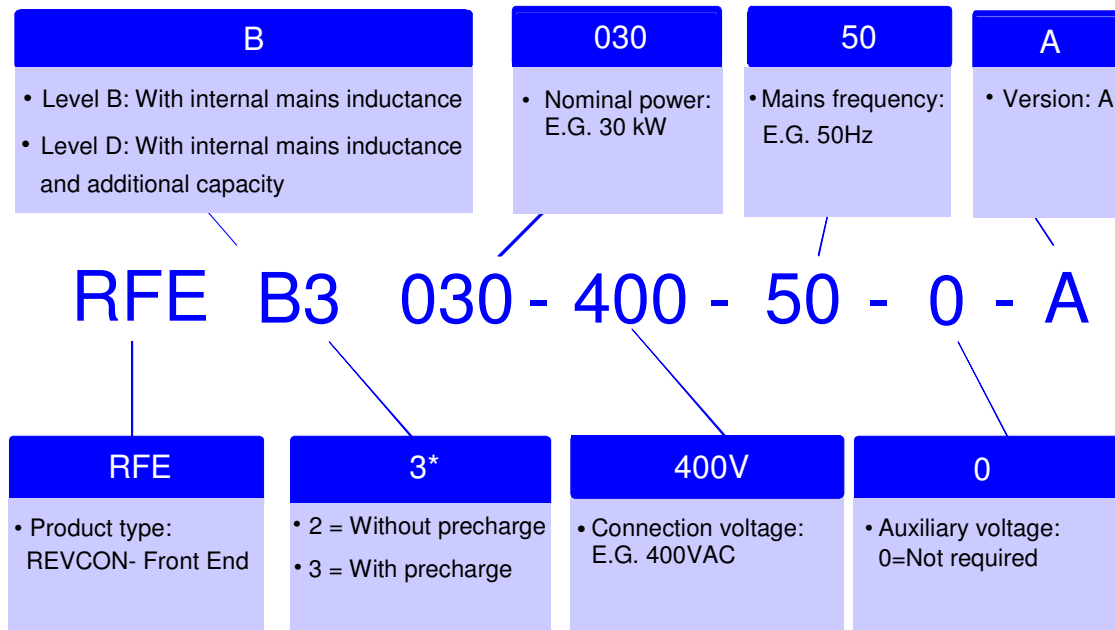

* Notes according to the ordering code:

- The precharge limiter of the REVCON® RFE B3/D3 is adapted (at a maximum switch-on frequency of 1/min) to the normally used DC-bus capacitance values of the controller.
- As the REVCON® RFE B2/D2 has got no switch on current limiter (preload circuit), it may **exclusively** used in combination with controllers, which are equipped with an internal preload circuit for their DC-bus capacitors!

1.2 Scope of delivery

- 1 Power feed/feedback unit REVCON® RFE
- 1 Operating Instructions

After receipt of delivery, check immediately whether the scope of supply matches with the accompanying papers. We do not accept any liability for deficiencies claimed subsequently.

Claim

- visible transport damage immediately to the forwarder
- visible deficiencies/incompleteness immediately to ELTROPLAN REVCON

1.3 Legal regulations

Labelling	Nameplate	CE-mark	Manufacturer
	Power feed/feedback units REVCON® RFE are unequivocally marked by the contents of the nameplate.	Conforms the EC Low Voltage Directive	ELTROPLAN-REVCON Edisonstraße 3 D-59199 Bönen
Patent rights	The power feed/feedback unit REVCON® is protected in Germany and Europe by patents: Patent-No.: DE 3938654C1 and Patent-Nr.: 90123584.6-2207 . Patent infringements become prosecute.		
Application as directed	<p>Power feed/feedback unit REVCON® RFE</p> <ul style="list-style-type: none"> • Must only be operated under the conditions prescribed in these instructions. • Are components <ul style="list-style-type: none"> – to feed/feedback electrical energy. – used for installation into a machine. – used for assembly together with other components to form a machine. • Are electric units for the installation into control cabinets or similar enclosed operating housing. • Comply with the requirements of the Low-Voltage Directive • Are not machines for the purpose of the Machinery Directive • Are not to be used as domestic appliances, but only for industrial purpose. <p>Drive systems with power feed/feedback unit REVCON® RFE</p> <ul style="list-style-type: none"> • Comply with the EMC-Directive if they are installed according to the guidelines of CE-typical drive systems. • Can be used <ul style="list-style-type: none"> – on public and non-public mains. – in industrial as well as residential and commercial premises. • The user is responsible for the compliance of this application with the EC directives . 		
Liability	<ul style="list-style-type: none"> • The information, data and notes in these Operating Instructions met the state of the art at the time of printing. Claims referring to power feed/feedback units which have already been supplied cannot be derived from information, illustrations and descriptions given in these Operation Instructions. • The specifications, processes and circuitry described in these Operating Instructions are for guidance only and must be adapted to your own specific application. ELTROPLAN-REVCON does not take responsibility for the suitability of the process and circuit proposals. • The indications given in these Operating Instructions describe the features of the product without warranting them. • ELTROPLAN-REVCON does not accept any liability for damage and operating interference caused by: <ul style="list-style-type: none"> – disregarding these instructions – unauthorized modifications to the power feed/feedback unit – operating errors – improper working on and with the power feed/feedback unit 		
Warranty	<ul style="list-style-type: none"> • Warranty conditions: see sales and delivery conditions of ELTROPLAN-REVCON GmbH. • Warranty claims must be made immediately after detecting defects or faults. • The warranty is void in all cases where liability claims cannot be made. 		
Disposal	Material	recycle	disposal
	Metal	●	-
	Plastic	●	-
	Printed-board assemblies	-	●

EC-declaration of conformity

According to the EC-Low Voltage Directive (2006/95/EEC)

The power feed/feedback units REVCON® RFE have been developed, designed and manufactured in accordance with the above mentioned EC-Directive and in sole responsibility of

**ELTROPLAN-REVCON Elektrotechnische Anlagen GmbH,
Edisonstraße 3, D-59199 Bönen**

Considered standards:

Standard	
DIN VDE 0160 5.88 +A1 / 4.89 +A2 / 10.88 PRDIN EN 50178 Class VDE 0160 / 11.94	Equipment of power installations with electronic components
EN 61558-1/A1	Safety of power transformers, power supplies, reactors and similar products
EN 60529	International protection rating
DIN VDE 0100	Guidelines for the design of power installations

Preface and general information

1.4.2 EC-directive Electromagnetic compatibility

EMC directive (89/336/EWG)

Replaced by: EMC-directive (2004/108/EG)

General:

The objective target describes article 4 (2004/108/EG), as follows:

The... designated devices must be so manufactured, that

(a) an intended operation of radio- and telecommunication devices and other devices is possible and

(b) the devices have an adequate stability against electromagnetically disturbances, so that an intended operation is possible.

EG-declaration by the manufacturer

in terms of the EG-standard EMC (2004/108/EG)

The listed REVCON[®] products are in terms of the EMC no independently recoverable products, this means only after integration in the overall system would they be rateable regarding to EMC. The rating became detected for typical plant constructions, but not for the several products.

**ELTROPLAN-REVCON Elektrotechnische Anlagen GmbH,
Edisonstraße 3, D-59199 Bönen**

1.4.3 EC-Directive Machinery

Machine directive (98/37/EG)
Changed by: Modification directive (2006/42/EG)

General:

Machinery means an assembly, fitted with or intended to be fitted with a drive system other than directly applied human or animal effort, consisting of linked parts or components, at least one of which moves, and which are joined together for a specific application.

EC-declaration of the manufacturer

in terms of the of the EC-Directive Machinery (2006/42/EG)

The power feed/feedback units REVCON® RFE have been developed, designed and manufactured in accordance with the above mentioned EC Directive in exclusive responsibility of

**ELTROPLAN-REVCON Elektrotechnische Anlagen GmbH,
Edisonstraße 3, D-59199 Bönen**

When installing the machines, commissioning (i.e. the starting of operation as directed) the power feed/feedback unit is prohibited until it is proven that the machine corresponds to the regulations of the EC Directive 2006/42/EG (Machinery Directive).

Safety information

2 Safety information



Safety and application notes for controller

(to : Low-Voltage Directive (2006/95/EEC))

1. General

During operation, power feed/feedback unit may have, according to their type of protection, live, bare, in some cases also movable or rotating parts as well as hot surfaces.

Non-authorized removal of required cover, inappropriate use, incorrect installation or operation, creates the risk of severe injury to persons or damage to material assets.

Further information can be obtained from the documentation.

All operations concerning transport, installation and commissioning as well as maintenance must be carried out by qualified, skilled personnel (IEC 364 and CENELEC HD 384 or DIN VDE 0100 and IEC-Report 664 or DIN VDE 0110 and national regulations for the preventions of accidents must be observed). According to this basic safety information qualified skilled personnel are persons who are familiar with the erection, assembly, commissioning and operation of the product and who have the qualifications necessary for their occupation .

2. Application as directed

Power feed/feedback units are components which are designed for installation in electrical systems or machinery.

When installing in machines, commissioning of the power feed/feedback unit (i.e. the starting of operation as directed) is prohibited until it is proven, that the machine corresponds to the regulations of the EC Directive 2006/42/EG (Machinery Directive); EN 60204 must be observed.

Commissioning (i.e. starting operation as directed) is only allowed when there is compliance with the EMC-Directive (2004/108/EG).

The power feed/feedback units meet the requirements of the Low-Voltage Directive (2006/95/EEC). The harmonized standards of the prEN 50178/DIN VDE 0160 series together with EN 60439-1/DIN VDE 0660 part 500 and EN 60146/DIN VDE 0558 are applicable for the power feed/feedback unit. The technical data and information on the connection conditions must be obtained from the nameplate and the documentation and must be observed in all cases.

3. Transport, Storage

Notes on transport, storage and appropriate handling must be observed.

At non-observance any warranty expires.

The power feed/feedback unit has to be protected from inadmissible stress.

The transport is only valid in original packaging and in the thereon by pictograms marked transport position.

In particular during transport and handling no components are allowed to be bent and / or isolating distances may not be altered.

The units are equipped with electrostatic sensitive devices, which may be damaged by improper handling. Therefore it has to be avoided to get in contact with electronic components. If electronic components are damaged mechanically the unit must not be put into operation, as it cannot be ensured, that all relevant standards are observed. Climatic conditions must be observed according to prEN 50178.

4. Erection

The devices must be erected and cooled according to the regulations of the corresponding documentation.

The power feed/feedback units must be protected from inappropriate loads. Particularly during transport and handling, components must not be bent and / or isolating distances must not be changed. Touching of electronic components and contacts must be avoided.

Power feed/feedback units contain electro-statically sensitive components which can easily be damaged by inappropriate handling. Electrical components must not be damaged or destroyed mechanically (health risk are possible!).

5. Electrical Connection

When working on live power feed/feedback units, the valid national regulations for the prevention of accidents (e.g. VBG 4) must be observed. Before any installation or connection works, the pant has to be switched off and to be secured properly.

The electrical installation must be carried out according to the appropriate regulations (e.g. cable cross-sections, fuses, PE-connection). More detailed information is included in the documentation. When using the power feed/feedback unit with controllers without safe separation from the supply line (to VDE 0100) all control wiring has to be include in further protective measures (e.g. double insulated or shielded, grounded and insulated).

Notes concerning the installation in compliance with EMC – such as screening, grounding, arrangement of filters and laying of cables – are included in the chapter installation of this documentation. These notes must be also observed in all cases for power feed/feedback units with the CE-mark. The compliance with the required limit values demanded by the EMC legislation is the responsibility of the manufacturer of the system or machine.

6. Operation

Systems where power feed/feedback units are installed, if applicable, have to be equipped with additional monitoring and protective devices according to the valid safety regulations e.g. law on technical tools, regulations for the prevention of accidents, etc.

After disconnecting the power feed/feedback unit from the supply voltage, live parts of the power feed/feedback unit and power connections must not be touched immediately, because of possibly charged capacitors. For this, observe the corresponding labels on the drive controllers.

During operation, all covers and doors must be closed.

7. Maintenance and service

The manufacturer's documentation must be observed.

This safety information must be kept!

The product-specific safety and application notes in these Operating Instructions must also be observed!

2.1 General safety information

- These safety regulations are not entitled to completeness. In case of questions please contact our technicians.
- When commissioning the power feed/feedback units are compliant with the state of the art. The power feed/feedback unit generally allows safe operation.
- The statements of this manual describe the attributes of the products without guaranteeing them.
- The power feed/feedback unit may expose persons, the power feed/feedback units itself and other material to danger, if
 - non-qualified personal works at and with the power feed/feedback unit.
 - The power feed/feedback unit is used in opposite to its purpose.
- Power feed/feedback units have to be projected in a way, that they fulfil their function and don't expose persons to danger, if they are mounted correctly and are used in accordance with their purpose. This applies also for the interplay with the whole plant.
- The units, operational data and circuit details described in this manual have to be understood analogously and have to be checked for transferability to each application.
- For the reasons of personal safety, the observance of the EMC-regulations and for the regular cooling the operation of the device is only allowed with a closed cover of the housing and with mounted flanges!
- Use the drive system only in flawless condition.
- Modifications of the power feed/feedback units without consultation of a REVCON[®]-technician are not allowed generally.

Safety information

- The warranty given by us expires, if the unit is modified or (even partially) dismantled or if it is used in contradiction to our instructions.
- The constructor of the plant, who has to know the technical guidelines, bears the responsibility for the correct selection and arrangement of the electrical components.
- Putting into operation of the power feed/feedback unit is only admissible at VDE-conform nets of electrical power supply. Non-observance may damage the device!
- In accordance with the corresponding standards and guidelines the operation on even for a short time over-compensated networks ($\cos\phi \leq 1$) respectively on un-choked compensation-units is not admissible. If this is done nevertheless, overvoltage will occur (caused by oscillating currents), which may damage all connected components, especially electronic units like controllers and power feed/feedback units.
- To low powered or unloaded generators and to regulating transformers it is never allowed to feed back power without a previous consultation of our application department. Otherwise unintended voltage rises / excess voltages are generated, which may damage or destroy REVCON® and combined units!
- Before operating at nets without reference to neutral ground additional safety measures (e.g. installation of over voltage suppressors like MOV's) have to be done. If necessary, please ask for technical support by our technicians.
- An undisturbed operation of the power feed/feedback unit is only probable, if the following instructions are observed. If these instructions are not observed, tripping of the unit and damages may occur.

Safety information

- Pay attention to the correct values of mains and DC-bus voltage.
 - Separate power and control wires (> 15cm)
 - Use shielded or twisted control wires. Connect both ends of the shield to ground!
 - When using the digital input devices, only use suitable switching devices, whose contacts are able to switch the connected voltages.
 - Connect the housings of drive, controller and power feed/feedback unit to ground carefully. Connect shields of power cables to ground at both ends with as big surface as possible (remove lacquer)!
 - Connect the cabinet or the plant by a star-shaped network to ground (ground loops have to be avoided!)
-
- The power feed/feedback unit has been designed for a fixed connection to mains only. Especially when using RFI-filter leakage current values > 3,5mA may occur. The cross section of the earthing conductor must be at least 10mm² copper, or a second conductor has to be connected in parallel (star shaped grounding network).
 - If components are used, which have no electrical separated inputs / outputs it is necessary to equalize the potentials (e.g. by an equalizing wire). If this is not observed these components may be damaged by equalizing currents.
 - When carrying out an insulations test in accordance with VDE0100/part 620 the device has to be disconnected to avoid damage to the power semiconductors. This procedure corresponds with the standard, as each device performs a high voltage test in accordance with VDE 0160 (EN 50178) in the course of final testing after manufacturing.

Safety information

- A standard fault-current circuit breaker (sensitive on peak currents) is not allowed to be used as the only protective measure when using controller and power feed/feedback unit. Caused by a DC-component in the mains current a controller with 3-phase input voltage may prevent a fault-current circuit breaker from tripping in case of an earth fault. In accordance with VDE 0160 a fault-current circuit breaker is not allowed to be used as the only protective measure. In dependence on the kind of network (TN, IT, TT) further protective measures in accordance with VDE 0100 part 410 are necessary. For a TN-network this may be an over current protection, for an IT-network a insulation supervision with pulscode-measurment. For all kind of networks protective insulation (-transformer) may be used, if required power and length of wires allow that. When selecting a fault current circuit breaker the following measures have to be considered:
 - The fault current circuit breaker has to be compliant with the VDE 0664 standard.
 - The tripping current should be 300mA or more, to prevent a premature tripping caused by the leakage current of the controller. In dependence on the load, the length of the motor cables and the usage of a RFI-filter the leakage current may even be much higher.

Fault current circuit breakers, which are sensitive to all kinds of leakage currents, grant a good protection and are suitable as the only protection measurement for one or three phase controllers. The connection instructions of the manufacturer have to be observed.

2.2 Safety-responsible persons

User

- User is any natural or legal entity, who uses the drive system or by whom order the drive system is used.
- The user respectively his security officer have to grant
 - that all relevant regulations, instructions and laws have to be observed
 - that only qualified personnel works with or at he drive system
 - that the relevant manual is available for the personnel during any works
 - that non-qualified personnel is prohibited to work on the drive system.

Qualified staff

Danger!



Qualified personnel are persons who are, based on their education, experience, instruction and knowledge about standards and guidelines, regulations for the prevention of accidents and the situation in the plant, authorized by the safety officer of the plant to execute the necessary works and are able to recognize possible dangers and to avoid them.

(Definition of qualified personnel in accordance with IEC 364)

Usage as directed

Danger!



Power feed/feedback units are electrical drive components, which are directed to be installed in electrical plants or machines. They have to be used only for drive systems with infinity variable speed controls of 3-phase asynchronous or permanent magnet motors. The usage with other electrical loads is not permitted and may damage the devices. The power feed/feedback unit may only be connected to symmetrical networks. Non-observance may damage the devices.

Safety information







2.3 Layout of the safety information

- All safety notes have a uniform layout:
 - The icon characterizes the type of danger.
 - The signal word characterizes the severity of danger.
 - The note describes the danger and suggests how to avoid the danger.



Signal word

Legend

	Used pictograms		Signal words	
Warning of injury to persons		Imminent danger by current	Danger!	Warns of an immediately imminent Danger. Consequences by disregard: Death or severe injuries
		Warning of a imminent danger	Warning!	Warns of a possible, very danger situation. Possible consequences by disregard: Death or severe injuries
		Dangerous situation	Caution!	Warns of a possible, dangerous situation. Possible consequences by disregard: Minor or small injuries
		Warning of hot surface	Warning!	Warns of touching a hot surface. Possible consequences by disregard: Burnings
Warning of property damages		Harmful situation	Stop!	Warns of possible property damages. Possible consequences by disregard: Damage of the drive system or its surroundings
Useful information and application notes		Information	Note!	Marks a generally, useful note, tip. If you follow it, you make the handling of the system easier

2.4 Residual hazards



Operator's safety

After mains disconnections, the power terminals + and – remain live for several minutes.

Protection of the device



Cyclic connection and disconnection of the supply voltage at terminals L1, L2 und L3, may overload the internal input current limitation:

Allow at least 1 minute between disconnection and reconnection.

2.5 General instructions

By this information to erectors and users of a plant hints on properties and directions concerning the power feed/feedback unit are given. These hints are not entitled to completeness.

Special features in comparison towards a chopper:

Unlike a braking resistor a power feed/feedback device isn't a constant sink, but it's dependent on the momentary characteristics of the supplying net. Commutation break downs and voltage-flicker in the net have a considerable effect to the backward current of the device. In case of a short time voltage brake down the backward current has to raise correspondingly to feed/feedback the demanded power-amount. Does the level of the supply voltage sink for a longer time, the maximum feed/feedback power is reduced.

If only one phase fails, the device is able to work on, but the current in the two remaining conductors will rise up to 150% of the normal level.

Safety information

Length of the DC-connection

The maximum inductivity of the DC-connection between output B6 Bridge of the inverter and the power feed/feedback device mustn't exceed a certain level, as this inductivity inducts an additional voltage to the DC-bus, when the IGBT's are switched off. To avoid an overload to the components of the power feed/feedback unit, this additional voltage must not exceed 100V. Resulting from this and other relevant characteristics of the power feed/feedback unit (DC-capacity and absolute maximum value of the grid current) the maximum inductivity can be calculated:

$$L_{\max} = \frac{C \cdot (\Delta U_{GL})^2}{\hat{i}^2} \qquad \hat{i}^2 = 2 \times I_{eff}$$

The maximal valid line inductance for the power feedback unit and the coupling inductance between the two conductors produce at a by the current carrying capacity-defined cross section of the lead of the cable a maximum length of the connecting cable:

$$L' = \frac{\mu_0 \cdot l}{\pi} \left(\ln \frac{a}{r} + 0,25 \right)$$

This inductivity always has to be higher or equal than the sum of the DC-bus inductivity of the frequency inverter and the conductor inductivity of the DC connection.

The DC-bus inductivity of the frequency inverter has only to be considered, if it is placed between the inverter B6 Bridge and the power feed-back unit. The cables, which are normally used for power applications, have an inductance per unit length of about 0,6µH/m. If the values of the input capacitance C, the during power feedback maximum allowed rise of the DC-voltage $\Delta U_{GL} = 100V$, the top level of the AC-current of the device ($=2 \times I_{eff}$), the inductance per unit length $L' = \frac{\mu_0 \cdot l}{\pi} \left(\ln \frac{a}{r} + 0,25 \right)$ and the inductance of the DC-bus 'choke L_{ZKD} are known the maximum longitude of the conductors can be calculated with the following equation:

$$l_{\max} = \frac{C \cdot \Delta U_{GL}^2}{\hat{i}^2 \cdot L'} - \frac{L_{ZKD}}{L'}$$

Typical capacitance of the DC-connection inside the power feed/feedback unit:

REVCON [®] -type	Power [kW]	DC-capacity [μF]
RFE B2/D2 400V	30	100
RFE B2/D2 400V	45	100
RFE B2/D2 400V	60	220
RFE B2/D2 400V	80	220
RFE B2/D2 400V	100	220
RFE B2/D2 400V	125	440
RFE B2/D2 400V	150	660
RFE B2/D2 400V	200	660
RFE B2/D2 400V	250	660

Table 2.6.1

Example:

C=200μF, ΔU_{GL}=100V, i=271A, a=80mm, r=8,5mm, μ₀=1,257·10⁻⁶ H/m

$$L' = \frac{\mu_0 l}{\pi} \left(\ln \frac{a}{r} + 0,25 \right) \quad I_{\max} = \frac{C \cdot \Delta U_{GL}^2}{\hat{i}^2 \cdot L'} - \frac{L_{ZKD}}{L'}$$

⇒ I_{max}=26m

For longer DC-Bus-wires additional capacitors have to be installed (please get in contact with our application-department if the occasion arises).

Safety information

Typical capacitance of the DC-connection inside the power feed/feedback unit:

REVCON®-type	Power [kW]	DC-capacity [μF]
RFE B3/D3 400V	30	100
RFE B3/D3 400V	45	100
RFE B3/D3 400V	60	220
RFE B3/D3 400V	80	220
RFE B3/D3 400V	100	220
RFE B3/D3 400V	125	440
RFE B3/D3 400V	150	660
RFE B3/D3 400V	200	880
RFE B3/D3 400V	250	880

Table 2.6.1

Example:

$C=200\mu\text{F}$, $\Delta U_{\text{GL}}=100\text{V}$, $i=271\text{A}$, $a=80\text{mm}$, $r=8,5\text{mm}$, $\mu_0=1,257 \cdot 10^{-6} \text{ H/m}$

$$L' = \frac{\mu_0 \cdot l}{\pi} \left(\ln \frac{a}{r} + 0,25 \right) \quad l_{\text{max}} = \frac{C \cdot \Delta U_{\text{GL}}^2}{\hat{i}^2 \cdot L'} - \frac{L_{\text{ZKD}}}{L'}$$

$$\Rightarrow l_{\text{max}}=26\text{m}$$

For longer DC-Bus-wires additional capacitors have to be installed (please get in contact with our application-department if the occasion arises).

Operation on a generator

The usage of a power feed/feedback unit within an island network (e.g. with a diesel generator) is possible, but there are restrictive regulations concerning the power limits.

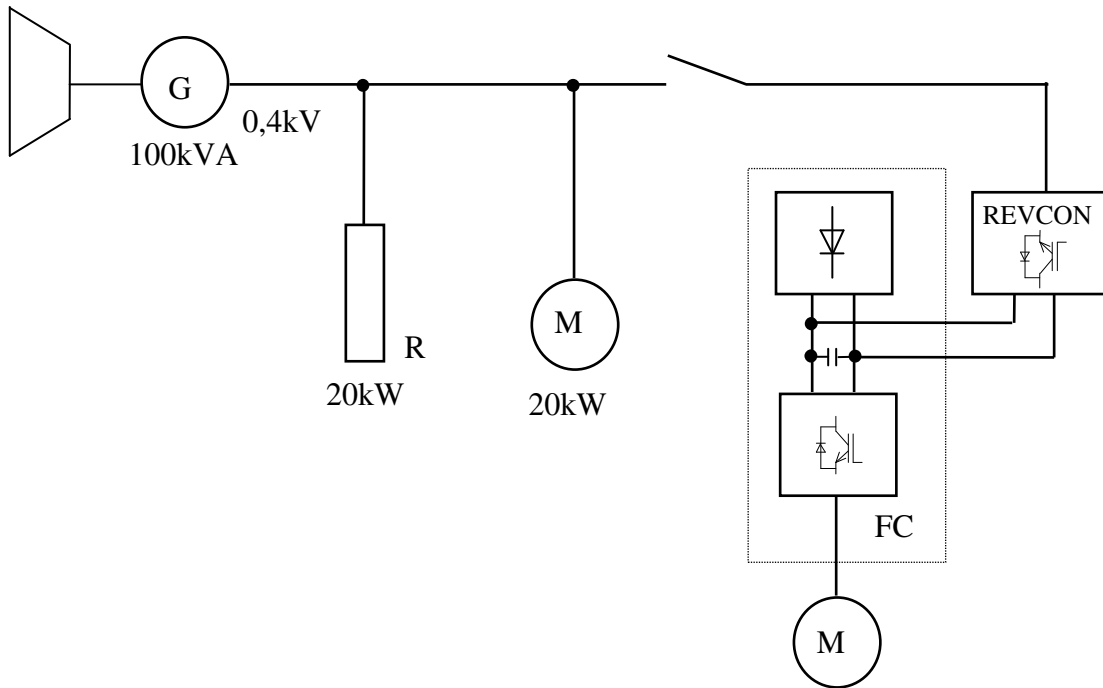

Figure 2.6.1

Within a network that is assembled like in figure 2.6.1, there are two additional restrictions: First the power of the motor connected to the inverter must be lower than half of the nominal power of the generator. Second the total amount of the power of the two other loads must be more than double of the feedback power.

If these conditions aren't checked up a change from motor to generator operation may result in load shocks. These shocks are too dynamic for the voltage regulator of the generator. The regulator reacts with an overshoot and as a result of this with an over voltage within the isolated network.

Danger!



Over voltages may cause serious damages to the connected frequency inverter and /or to the power feed/feedback unit and to the other loads.

Safety information

Operation on a transformer

If only a few loads operate within a network section the connected transformer must be able to transport the in this section not used power back to the next voltage level without producing a not allowed voltage increase inside the section. Therefore the nominal power of the transformer has to be one and a half higher than the feedback power out of the section, so that also the harmonic and reactive components of the current can be transmitted. In the network section displayed in figure 2.6.2 these conditions are checked up, even if the other loads are switched off.

Is the feedback power in the order of the nominal power of the transformer, it's impedance voltage has to be small enough (max. 6%) to limit the voltage increase in the section.

The operation of the power feed/feedback unit in combination with an adjusting transformer (e.g. in the case of a braked slip-ring induction motor) is only allowed, if the quotient ratio of feed/feedback-power and nominal power is much smaller than one.

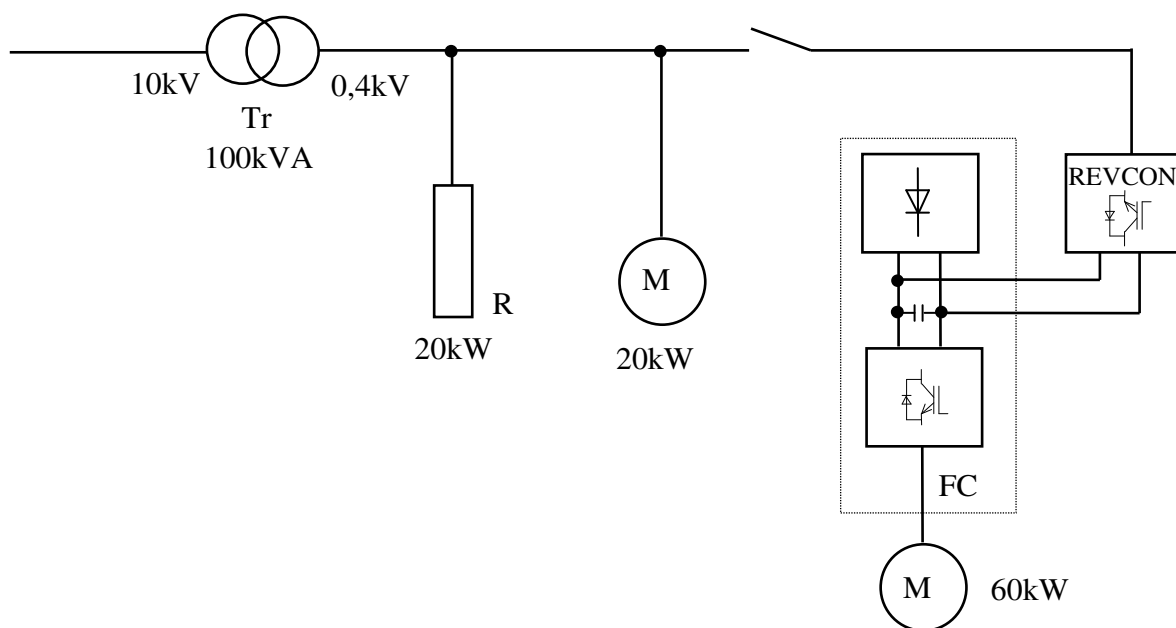

Figure 2.6.2

Placing of the commutation choke

If the frequency converter is connected to an external commutation choke, the connection of the power feed/feedback unit has to be done at its network terminals (figure 2.6.3). Is the connection done at the load terminals of the commutation choke it's inductivity prevents the synchronising to the supplying net and the induction voltage of the choke when it is switched of under load may result in damages to the power feed/feedback device.



Danger!

Over voltages may cause serious damages to the connected frequency inverter and /or to the power feed/feedback unit and to the other loads.

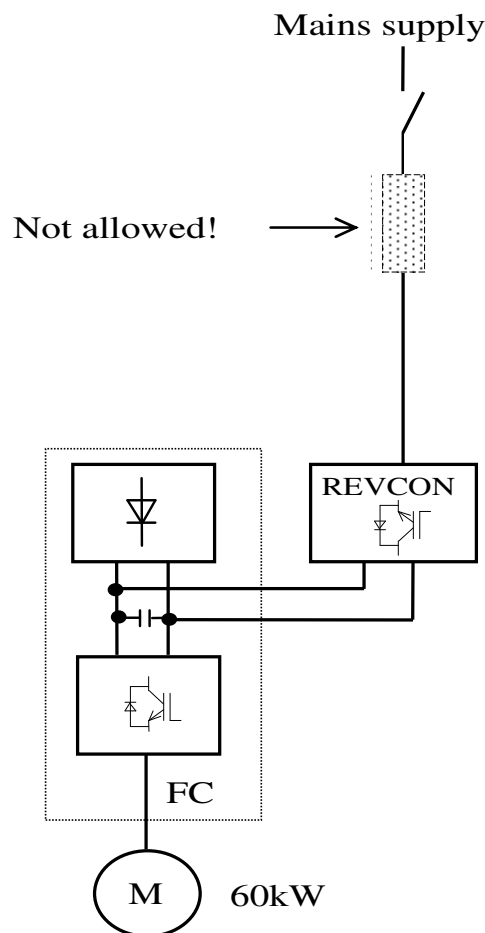

Figure 2.6.3

The same things apply to the also non-admissible pre-connection of further commutation chokes.

Safety information

Line and contact resistances

The values of current carrying capacity of conductors refer to the most often used copper conductors. Concerning to their higher specific resistance aluminium conductors must have greater dimensions.

Regardless of which conducting materials are used, the contact terminals of the conductors have to be low resistive and their number has to be reduced to the necessary minimum.

Too much or too high resistive terminals may result in a unsafe voltage magnification during the power feed/feedback operation.

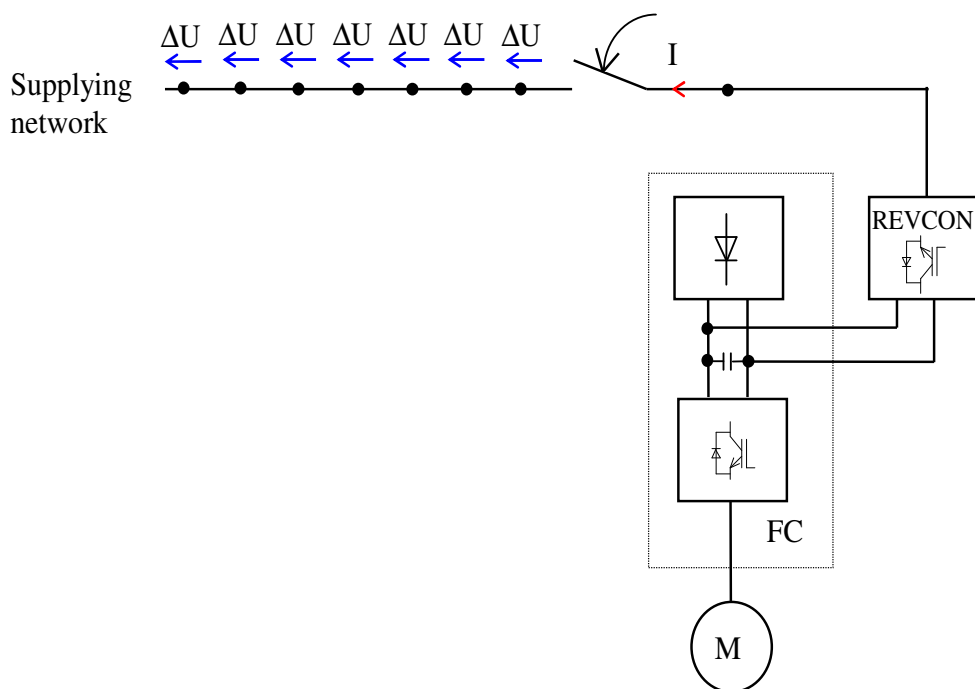

Figure 2.6.4

Proceeding from a stable network with e.g. 400V nominal voltage and a backward current of 80A, at a bad made terminal of 100mW a voltage of 8V is dropped (A good made terminal has got a resistance of ca 1 mW.). During feedback operation at seven serial terminals at the net switch results a voltage of 456V.

Safety information



Danger!

Over voltages may cause serious damages to the connected frequency inverter and /or to the power feed/feedback unit and to the other loads.

Current capacity of copper conductors for frequency inverters and power feed/feedback operation

Conductor cross section per phase [mm ²]	Conductor radius [mm]	Fuse [A]	Max. permanent current [A]
16	2,3	63	46
25	2,8	80	59
35	3,3	100	73
50	4,0	125	90
70	4,7	160	106
95	5,5	200	140
120	6,2	250	206
185	7,7	315	250
2x120	2x6,2	400	300
2x150	2x6,9	500	390
2x185	2x7,7	630	485
3x185	3x7,7	800	570
3x240	3x8,7	1000	740
4x240	4x8,7	1250	920

These values are based on a cable length of 100m and a maximum voltage drop of 5V.

Table 2.6.2

Safety information

Connection of further loads

The connection of further loads (e.g. cabinet ventilation or climatisation) parallel to the frequency inverter / power feed/feedback unit at a common circuit breaker like in figure 2.6.5 is not allowed. If it's done nevertheless, in case of tripping of the circuit breaker the connection to the network (energy sink and synchronising element for the power feed/feedback unit) misses. The IGBT's now switch the DC-voltage directly to the other loads. The resulting nearly rectangular "net"-voltage drives a current through the loads, which level and form depends on their impedance. Is the power consumption of the loads too small, the DC-voltage and also the output voltage of the power feed/feedback unit rises during the feedback operation. This increased voltage may damage all connected components.

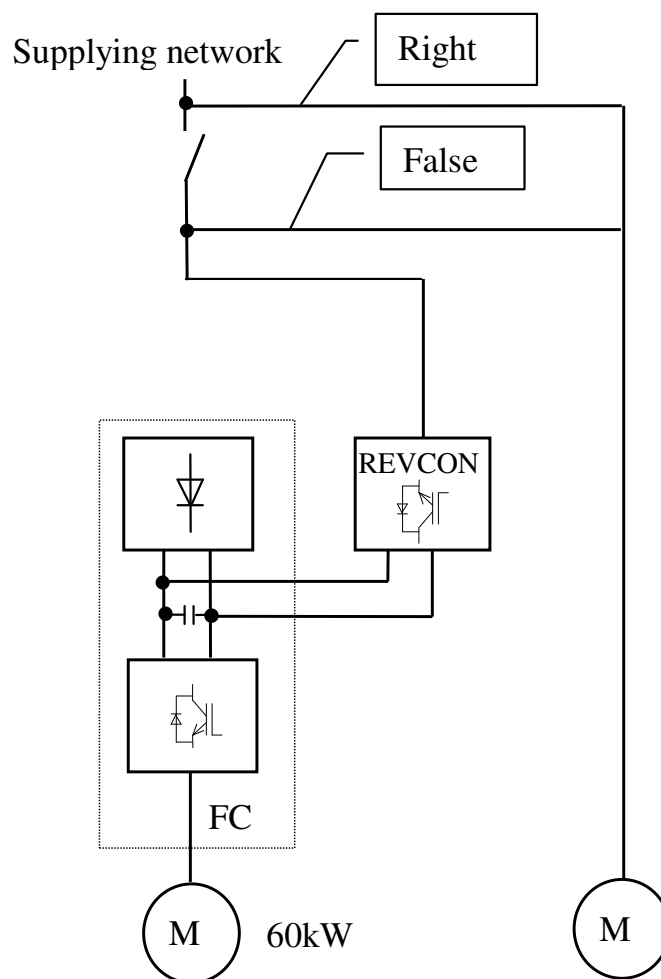

Figure 2.6.5

Safety information



Danger!

Over voltages may cause serious damages to the connected controller and /or to the power feed/feedback unit and to the other loads.

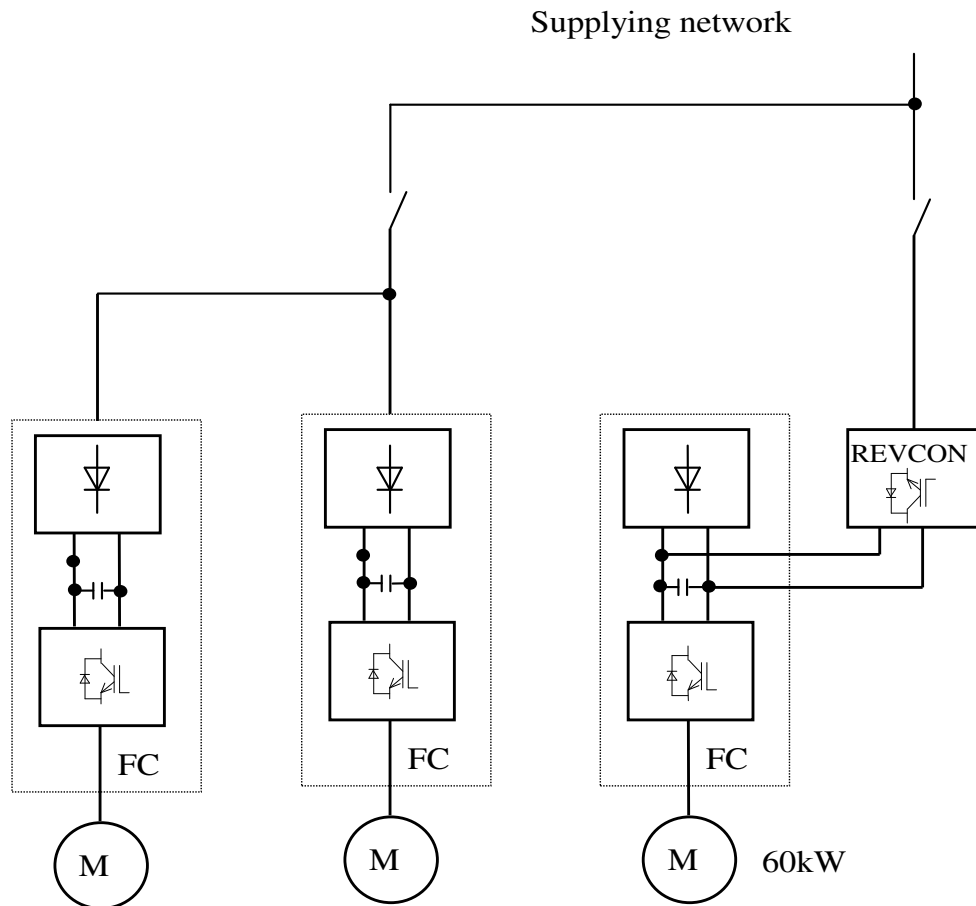

Figure 2.6.6

Note!



Same things apply to the structure like in figure 2.6.6. Even in this case it is necessary to place a circuit breaker in each feedback current circuit.

Safety information

Unchoked compensation plants and resonance rise

Compensation plants are used in the centre of the power supply of a company. Disturbances or damages at these plants have effects on the power supply and may result in interrupted production processes.

Although this is no longer state of the art, many compensation plants are in operation without any choking. The problems, which result from a usage of such an unchoked compensation plant, are manifold:

- direct resonance
- resonance rise
- switching transients or
- impairments of centralized ripple systems

The fact, that a company produces back effects to the power supply is not the only reason for the creation of resonance. Decisive for the risk, to generate a resonance is the compensation power at the medium voltage transformer. The higher this power is, the higher is the risk of resonance. The second important factor is the harmonic load of the medium voltage level. This harmonic load is transmitted via the transformer and causes effects on the low voltage level. Most often the limits were exceeded for the 5th harmonic component.

3 Technical data

3.1 Characteristics

- Small compact housing
 - Power supply for one or more controllers
 - Braking power of controller is fed back into mains
 - DC-bus coupling of several controllers possible
 - IGBT power modules with high efficiency and high service reliability
 - Self synchronising
 - Overload protection during feedback operation
 - Supervision of mains voltage, phase sequence and temperature
 - High efficiency
 - High dynamic braking processes are possible
 - User-friendly commissioning – no adjustment necessary
-
- RFE B2 and RFE D2: Power range 30kW-250kW
Available for mains voltages 400V, 460V and 500V
 - RFE B3 und D3: Power range 30kW to 285kW (855kW by parallel connection)
Available for mains voltages 400V, 460V, 500V (230V and 690V on request)

Technical data

3.2 General data / application conditions

Range	Values
Permissible temperature range*	During transport of the unit: -25°C...+70°C (to VDE 0160) During storage of the unit: -25°C...+55°C (to VDE 0160) During operation of the unit: 5°C... +40°C without power derating 40°C...+55°C with power derating
Humidity class*	Humidity class F without condensation (5% - 85% relative humidity)
Environment: Resonance search	Base standard: DIN EN 60068-2-6 Test specification: 5 Hz, 150 Hz, 3 directions (0,5 g, 0,1 g, 0,5 g)
Environment: Sine vibration test	Base standard: DIN EN 60068-2-6 Test specification: (5 Hz-13,2 Hz)-150 Hz 2 mm peak to peak 0,7g
Installation height h*	H ≤ 1000 m a.m.s.l. without power derating 1000 m a.m.s.l. < h 4000 m a.m.s.l. with power derating
Air pressure*	86kPa – 106kPa to VDE0875 part 11 and prEN55082
Degree of pollution	VDE 0110 Part 2 degree 2
Noise immunity	EN 61000-4-4 degree 4 EN 61000-4-2 degree 3 EN 61000-6-2 criterion A
Insulation strength	Overvoltage category III according to VDE 0110
Packaging	DIN 55468 for transport packaging materials
Transport: Random vibration test	Base standard: DIN EN 60068-2-64 Base standard: DIN EN 30786-2
Transport: Mechanical shock test	Base standard: DIN EN 60068-2-27 Base standard: DIN EN 30786-2
Type of protection	IP 20
Approvals	CE: Low-Voltage Directive

*Climatic conditions according to class 3K3 (EN 50178 Part 6.1)

3.3 Rated data

3.3.1 Power feed - and feedback unit REVCON RFE B2/D2

REVCON- type		RFE B2/D2 400V	RFE B2/D2 460V	RFE B2/D2 500V
Nominal range of the interlinked mains voltage	U_N [V]	-15% / +10%	-15% / +10%	-15% / +10%
Mains frequency	f_N [Hz]	40 - 60 ± 10 %		
Overload capability		(see tables 3.4.2.1 to 3.4.2.3)		
Efficiency	η [%]	ca. 98 % (2 % thermal losses)		
Power factor	cos φ	~ 1		
Fundamental frequency component	g	~ 0,7- 0,95		
* Required airflow	m ³ / h	a) RFE-B2/D2 30-400, 45-400, 60-400, RFE-B2/D2 30-460, 45-460, 30-500, 45-500 : 350 b) RFE-B2/D2 80-400, 60-460, 60-500 : 450 c) RFE-B2/D2 100-400, 125-400, 150-400, 200-400 RFE-B2/D2 80-460, 100-460, 125-460, 150-460 RFE-B2/D2 80-500, 100-500, 125-500, 150-500 : 700		
Power derating	[%/K]	40°C < Ta < 55°C ⇒ 3%/K		
	[%/m]	1000m üNN < h ≤ 4000m üNN ⇒ 5%/1000m		

Table 3.3.1.1

* Depending on the size of the unit (nominal power and nominal voltage)

Technical data

3.3.2 Power feed- and feedback unit REVCON RFE B3/D3

REVCON- type		RFE B3/D3 400V	RFE B3/D3 460V	RFE B3/D3 500V
Nominal range of the interlinked mains voltage	$U_N[V]$	-10% / +10%	-10% / +10%	-10% / +10%
Tolerance of the interlinked mains voltage	$U_N[V]$	$342 \leq U_N \leq 456$	$396 \leq U_N \leq 528$	$450 \leq U_N \leq 550$
Mains frequency	$f_N[Hz]$	40 - 60 ± 10 %		
Overload capability		(see tables 3.4.3.1 to 3.4.3.3)		
Efficiency	$\eta[\%]$	ca. 98 % (2 % thermal losses)		
Power factor	$\cos\phi$	~ 1		
Fundamental frequency component	g	~ 0,7- 0,95		
* Required airflow	m^3 / h	a) RFE-B3/D3 30-400, 45-400, 60-400, RFE-B3/D3 30-460, 45-460, 30-500, 45-500 : 350 b) RFE-B3/D3 80-400, 60-460, 60-500 : 450 c) RFE-B3/D3 100-400, 125-400, 150-400, 200-400 RFE-B3/D3 80-460, 100-460, 125-460, 150-460 RFE-B3/D3 80-500, 100-500, 125-500, 150-500 : 700		
Power derating	$[\%/K]$	$40^\circ C < T_a < 55^\circ C \Rightarrow 3\%/K$		
	$[\%/m]$	$1000m \ddot{u}NN < h \leq 4000m \ddot{u}NN \Rightarrow 5\%/1000m$		

Table 3.3.2.1

* Depending on the size of the unit (nominal power and nominal voltage)

3.4 Ampacity

3.4.1 REVCON RFE B2/D2

Nominal voltage 400V

REVCON® - Type RFE B2/D2	REVCON® - item-Nr.:	Driving		Braking	
		AC Max. input current I _{eff}	DC Max. input current I	AC Max. current I _{eff}	DC Max. current I
30-400-50-230-A	22012004 / 22016004	65 A	79 A	52 A	62 A
45-400-50-230-A	22012005 / 22016005	98 A	118 A	78 A	94 A
60-400-50-230-A	22012006 / 22016006	130 A	157 A	104 A	125 A
80-400-50-230-A	22012007 / 22016007	173 A	209 A	139 A	167 A
100-400-50-230-A	22012008 / 22016008	217 A	260 A	173 A	208 A
125-400-50-230-A	22012009 / 22016009	271 A	328 A	217 A	260 A
150-400-50-230-A	22012010 / 22016010	325 A	390 A	260 A	312 A
200-400-50-230-A	22012011 / 22016011	433 A	520 A	346 A	415 A
250-400-50-230-A	22012012 / 22016012	541 A	649 A	433 A	520 A
300-400-50-230-A	22012013 / 22016013	650 A	780 A	520 A	624 A

Table 3.4.1.1

Nominal voltage 460V

REVCON® - Type RFE B2/D2	REVCON® - item-Nr.:	Driving		Braking	
		AC Max. input current I _{eff}	DC Max. input current I	AC Max. input I _{eff}	DC Max. current I
30-460-60-115-A	22012024 / 22016024	56 A	67 A	45 A	54 A
45-460-60-115-A	22012025 / 22016025	85 A	102 A	68 A	82 A
60-460-60-115-A	22012026 / 22016026	113 A	136 A	90 A	108 A
80-460-60-115-A	22012027 / 22016027	151 A	181 A	120 A	144 A
100-460-60-115-A	22012028 / 22016028	188 A	228 A	151 A	181 A
125-460-60-115-A	22012029 / 22016029	236 A	283 A	188 A	227 A
150-460-60-115-A	22012030 / 22016030	282 A	338 A	226 A	271 A
200-460-60-115-A	22012031 / 22016031	377 A	452 A	301 A	361 A
230-460-60-115-A	22012031 / 22016031	377 A	452 A	301 A	361 A

Table 3.4.1.2

Technical data

Nominal voltage 500V

REVCON® - Type RFE B2/D2	REVCON® - item-Nr.:	Driving		Braking	
		AC Max. input current I_{eff}	DC Max. input current I	AC Max. current I_{eff}	DC Max. current I
30-500-50-230-A	22012124 / 22016124	52 A	63 A	42 A	50 A
45-500-50-230-A	22012125 / 22016125	79 A	97 A	62 A	74 A
60-500-50-230-A	22012126 / 22016126	104 A	125 A	83 A	100 A
80-500-50-230-A	22012127 / 22016127	139 A	167 A	111 A	133 A
100-500-50-230-A	22012128 / 22016128	173 A	209 A	139 A	167 A
125-500-50-230-A	22012129 / 22016129	217 A	260 A	173 A	208 A
150-500-50-230-A	22012130 / 22016130	260 A	312 A	208 A	250 A
200-500-50-230-A	22012131 / 22016131	346 A	415 A	277 A	332 A
230-500-50-230-A	22012132 / 22016132	398 A	478 A	319 A	383 A

Table 3.4.1.3

3.4.2 Dimensioning REVCON RFE B2/D2

	Driving				Braking			
	Flyback diodes				IGBT-modules			
	P [kW]	I _{eff/Phase} [A]	P [kW]	I _{eff/Phase} [A]	P [kW]	I _{eff/Phase} [A]	P [kW]	I _{eff/Phase} [A]
Device type: RFE B2/D2	100%		150% 1 min in 10 min		100%		150% 1 min in 10 min	
30-400-50-230-A	30	43	45	65	24	35	36	52
45-400-50-230-A	45	65	68	98	36	52	54	78
60-400-50-230-A	60	87	90	130	48	69	72	104
80-400-50-230-A	80	115	120	173	64	92	96	139
100-400-50-230-A	100	144	150	217	80	115	120	173
125-400-50-230-A	125	180	188	271	100	144	150	217
150-400-50-230-A	150	217	225	325	120	173	180	260
200-400-50-230-A	200	289	300	433	160	231	240	346
250-400-50-230-A	250	361	375	541	200	289	300	433
300-400-50-230-A	300	433	450	650	240	346	360	520

Table 3.4.2.1:

All values refer to a mains voltage of 400V

	Driving				Braking			
	Flyback diodes				IGBT-modules			
	P [kW]	I _{eff/Phase} [A]	P [kW]	I _{eff/Phase} [A]	P [kW]	I _{eff/Phase} [A]	P [kW]	I _{eff/Phase} [A]
Device type: RFE B2/D2	100%		150% 1 min in 10 min		100%		150% 1 min in 10 min	
30-460-60-115-A	30	38	45	56	24	30	36	45
45-460-60-115-A	45	56	68	85	36	45	54	68
60-460-60-115-A	60	75	90	113	48	60	72	90
80-460-60-115-A	80	100	120	151	64	80	96	120
100-460-60-115-A	100	126	150	188	80	100	120	151
125-460-60-115-A	125	157	188	236	100	126	150	188
150-460-60-115-A	150	188	225	282	120	151	180	226
200-460-60-115-A	200	251	300	377	160	201	240	301
230-460-60-115-A	230	289	345	433	184	231	276	346

Table 3.4.2.2:

All values refer to a mains voltage of 460V

Technical data

	Driving				Braking			
	Flyback diodes				IGBT-modules			
	P [kW]	I _{eff/Phase} [A]	P [kW]	I _{eff/Phase} [A]	P [kW]	I _{eff/Phase} [A]	P [kW]	I _{eff/Phase} [A]
Device type: RFE B2/D2	100%		150% 1 min in 10 min		100%		150% 1 min in 10 min	
30-500-50-230-A	30	35	45	52	24	28	36	42
45-500-50-230-A	45	52	68	79	36	42	54	62
60-500-50-230-A	60	69	90	104	48	55	72	83
80-500-50-230-A	80	92	120	139	64	74	96	111
100-500-50-230-A	100	115	150	173	80	92	120	139
125-500-50-230-A	125	144	188	217	100	115	150	173
150-500-50-230-A	150	173	225	260	120	139	180	208
200-500-50-230-A	200	231	300	346	160	185	240	277
230-500-50-230-A	230	266	345	398	184	212	276	319

Table 3.4.2.3:

All values refer to a mains voltage of 500V

Note!

Like the input of a controller the input of the REVCON®-feed- and feedback unit is not protected for overload. Therefore it is necessary to pay attention not to exceed the maximum input current of the REVCON® unit when designing the plant. If the maximum input current of the controller exceeds this value nevertheless, the motor current limit of the controller must be adjusted on the maximum REVCON value. In any case it is important to calculate with the overload factor of the controller.



Note!

To calculate the correct value of regenerating power it is necessary to note, that the real momentary regenerating power is dependent on the real existing main circuit voltage at any time. To calculate the regenerative power the following formula should be used:

$$P = U_{\text{eff}} \cdot I_{\text{eff}} \cdot \sqrt{3} \cdot \cos\varphi \quad (\text{during regenerative operation: } \cos\varphi = 1)$$

The maximum possible regenerative power is calculated based on the momentary rms mains voltage and the maximum rms current of the respective device.



Example:

Model DCV 60 with rated feedback power of 45kW, maximum rated rms current 65A (refer to technical data), nominal mesh voltage rating e.g. 400V.

From that results: $P=400V \times 65A \times \sqrt{3}=45033W$, that's about 45,0kW

If the momentary rms mains voltage is only 395V or even lower for a short time, the maximum possible regenerative power is reduced as well:

$$P = 395V \times 65A \times \sqrt{3} = 44470W, \text{ that's about } 44,5kW.$$

Technical data

3.5 REVCON RFE B3/D3

Nominal voltage 400V

REVCON® - type RFE B3/D3	REVCON® - item-Nr.:	Driving		Braking	
		AC Max. input current I_{eff}	DC Max. input current I	AC Max. current I_{eff}	DC Max. current I
30-400-50-230-A	22013004 / 22017004	65 A	78 A	52 A	62 A
45-400-50-230-A	22013005 / 22017005	98 A	118 A	78 A	97 A
60-400-50-230-A	22013006 / 22017006	130 A	156 A	104 A	125 A
80-400-50-230-A	22013007 / 22017007	173 A	208 A	139 A	167 A
100-400-50-230-A	22013008 / 22017008	217 A	260 A	173 A	208 A
125-400-50-230-A	22013009 / 22017009	271 A	325 A	217 A	260 A
150-400-50-230-A	22013010 / 22017010	325 A	390 A	260 A	312 A
200-400-50-230-A	22013011 / 22017011	433 A	520 A	346 A	415A
250-400-50-230-A	22013012 / 22017012	541 A	649 A	433 A	520 A

Table 3.5.1.1

Nominal voltage 460V

REVCON® - type RFE B3/D3	REVCON® - item-Nr.:	Driving		Braking	
		AC Max. input current I_{eff}	DC Max. input current I	AC Max. current I_{eff}	DC Max. current I
30-460-60-115-A	22013024 / 22017024	56 A	67 A	45 A	54 A
45-460-60-115-A	22013025 / 22017025	85 A	102 A	68 A	82 A
60-460-60-115-A	22013026 / 22017026	113 A	136 A	90 A	108 A
80-460-60-115-A	22013027 / 22017027	151 A	181 A	120 A	144 A
100-460-60-115-A	22013028 / 22017028	188 A	227 A	151 A	181 A
125-460-60-115-A	22013029 / 22017029	236 A	283 A	188 A	227 A
150-460-60-115-A	22013030 / 22017030	282 A	338 A	226 A	271 A
200-460-60-115-A	22013031 / 22017031	346 A	415 A	277 A	332 A
230-460-60-115-A	22013032 / 22017032	433 A	520 A	346 A	415 A

Table 3.5.1.1

Technical data

Nominal voltage 500V

REVCON® - type RFE B3/D3	REVCON® - item-Nr.:	Driving		Braking	
		AC Max. input current I_{eff}	DC Max. input current I	AC Max. current I_{eff}	DC Max. current I
30-500-50-230-A	22013124 / 22017124	52 A	62 A	42 A	50 A
45-500-50-230-A	22013125 / 22017125	79 A	95 A	62 A	74 A
60-500-50-230-A	22013126 / 22017126	104 A	125 A	83 A	100 A
80-500-50-230-A	22013127 / 22017127	139 A	167 A	111 A	133 A
100-500-50-230-A	22013128 / 22017128	173 A	208 A	139 A	167 A
125-500-50-230-A	22013129 / 22017129	217 A	260 A	173 A	208 A
150-500-50-230-A	22013130 / 22017130	260 A	312 A	208 A	250 A
200-500-50-230-A	22013131 / 22017131	346 A	415 A	277 A	332 A
230-500-50-230-A	22013132 / 22017132	398 A	478 A	319 A	383 A

Table 3.5.1.1

Technical data

3.5.1 Dimensioning REVCON RFE B3/D3

	Driving				Braking			
	Flyback diodes				IGBT-modules			
	P [kW]	I _{eff/Phase} [A]	P [kW]	I _{eff/Phase} [A]	P [kW]	I _{eff/Phase} [A]	P [kW]	I _{eff/Phase} [A]
Device type: RFE B3/D3	100%		150% 1 min in 10 min		100%		150% 1 min in 10 min	
30-400-50-230-A	30	43	45	65	24	35	36	52
45-400-50-230-A	45	65	68	98	36	52	54	78
60-400-50-230-A	60	87	90	130	48	69	72	104
80-400-50-230-A	80	115	120	173	64	92	96	139
100-400-50-230-A	100	144	150	217	80	115	120	173
125-400-50-230-A	125	180	188	271	100	144	150	217
150-400-50-230-A	150	217	225	325	120	173	180	260
200-400-50-230-A	200	289	300	433	160	231	240	346
250-400-50-230-A	250	361	375	541	200	289	300	433

Table 3.5.1.1.1:

All values refer to a mains voltage of 400V

	Driving				Braking			
	Flyback diodes				IGBT-modules			
	P [kW]	I _{eff/Phase} [A]	P [kW]	I _{eff/Phase} [A]	P [kW]	I _{eff/Phase} [A]	P [kW]	I _{eff/Phase} [A]
Device type: RFE B3/D3	100%		150% 1 min in 10 min		100%		150% 1 min in 10 min	
30-460-60-115-A	30	38	45	56	24	30	36	45
45-460-60-115-A	45	56	68	85	36	45	54	68
60-460-60-115-A	60	75	90	113	48	60	72	90
80-460-60-115-A	80	100	120	151	64	80	96	120
100-460-60-115-A	100	126	150	188	80	100	120	151
125-460-60-115-A	125	157	188	236	100	126	150	188
150-460-60-115-A	150	188	225	282	120	151	180	226
200-460-60-115-A	200	251	300	377	160	201	240	301
230-460-60-115-A	230	289	345	433	184	231	276	346

Table 3.5.1.1.2:

All values refer to a mains voltage of 460V

Technical data

	Driving				Braking			
	Flyback diodes				IGBT-modules			
	P [kW]	I_{eff/Phase} [A]	P [kW]	I_{eff/Phase} [A]	P [kW]	I_{eff/Phase} [A]	P [kW]	I_{eff/Phase} [A]
Device type: RFE B3/D3	100%		150% 1 min in 10 min		100%		150% 1 min in 10 min	
30-500-50-230-A	30	35	45	52	24	28	36	42
45-500-50-230-A	45	52	68	79	36	42	54	62
60-500-50-230-A	60	69	90	104	48	55	72	83
80-500-50-230-A	80	92	120	139	64	74	96	111
100-500-50-230-A	100	115	150	173	80	92	120	139
125-500-50-230-A	125	144	188	217	100	115	150	173
150-500-50-230-A	150	173	225	260	120	139	180	208
200-500-50-230-A	200	231	300	346	160	185	240	277
230-500-50-230-A	230	266	345	398	184	212	276	319

Table 3.5.1.1.3:

All values refer to a mains voltage of 500V

Note!



Like the input of a controller the input of the REVCON®-feed- and feedback unit is not protected for overload. Therefore it is necessary to pay attention not to exceed the maximum input current of the REVCON® unit when designing the plant. If the maximum input current of the controller exceeds this value nevertheless, the motor current limit of the controller must be adjusted on the maximum REVCON value. In any case it is important to calculate with the overload factor of the controller.

Technical data

Note!

To calculate the correct value of regenerating power it is necessary to note, that the real momentary regenerating power is dependent on the real existing main circuit voltage at any time. To calculate the regenerative power the following formula should be used:

$$P = U_{\text{eff}} \cdot I_{\text{eff}} \cdot \sqrt{3} \cdot \cos\varphi \quad (\text{during regenerative operation: } \cos\varphi = 1)$$

The maximum possible regenerative power is calculated based on the momentary rms mains voltage and the maximum rms current of the respective device.



Example:

Model DCV 60 with rated feedback power of 45kW, maximum rated rms current 65A (refer to technical data), nominal mesh voltage rating e.g. 400V.

From that results: $P=400V \times 65A \times \sqrt{3}=45033W$, that's about 45,0kW

If the momentary rms mains voltage is only 395V or even lower for a short time, the maximum possible regenerative power is reduced as well:

$$P = 395V \times 65A \times \sqrt{3} = 44470W, \text{ that's about } 44,5kW.$$

3.6 Fuses and wire cross sections

The power feed/feedback unit is connected to mains supply via the terminals L₁-L₃ at the terminal plate. Mains fuses must be designed according to the current load capacity of the supply wire.

3.6.1 Series fuses REVCON RFE B2/D2

Semiconductor fuses have to be connected in series with the power feed/feedback unit as following tables (refer to figure 5.6.1 to 511.1 position 1). The listed manufacturer is recommended, but naturally also comparative fuses of other manufacturer (e.g. Jean Müller, Ferraz, and Bussmann) are suitable.

REVCON® - type	Max. fuse AC	Connection terminal and max. cross section of the supply line*
RFE B2/D2 30-400-50-230-A	Siba 5014006.80 80A 690V 22x58mm	ES 25mm ²
RFE B2/D2 45-400-50-230-A	Siba 5007406.125 125A 690V 22x58mm	ES 25mm ²
RFE B2/D2 60-400-50-230-A	Siba 2018920.160 160A 690V NH 00	ES 25mm ²
RFE B2/D2 80-400-50-230-A	Siba 2018920.160 160A 690V NH 00	ES 50mm ²
RFE B2/D2 100-400-50-230-A	Siba 2018920.200 200A 690V NH 00	ES 50mm ²
RFE B2/D2 125-400-50-230-A	Siba 2018920.350 350A 690V NH 00	ES 150mm ²
RFE B2/D2 150-400-50-230-A	Siba 2071332.400 400A 1250V NH 1	ES 150mm ²
RFE B2/D2 200-400-50-230-A	Siba 2071332.500 500A 1100V NH 1	ES 240mm ²
RFE B2/D2 250-400-50-230-A	Siba 2071332.630 630A 1110V NH 1	ES 240mm ²
RFE B2/D2 300-400-50-230-A	Siba 2071332.800 800A 1110V NH 1	AE 240mm ²

Table 3.6.1.1

REVCON® - type	Max. fuse AC	Connection terminal and max. cross section of the supply line*
RFE B2/D2 30-460-60-115-A	Siba 5014006.100 100A 690V 22x58mm	ES 25mm ²
RFE B2/D2 45-460-60-115-A	Siba 5007406.125 125A 690V 22x58mm	ES 25mm ²
RFE B2/D2 60-460-60-115-A	Siba 2018920.160 160A 690V NH 00	ES 50mm ²
RFE B2/D2 80-460-60-115-A	Siba 2018920.200 200A 690V NH 00	ES 50mm ²
RFE B2/D2 100-460-60-115-A	Siba 2018920.315 315A 690V NH 00	ES 50mm ²
RFE B2/D2 125-460-60-115-A	Siba 2018920.350 350A 690V NH 00	ES 150mm ²
RFE B2/D2 150-460-60-115-A	Siba 2071332.400 400A 1250V NH 1	ES 150mm ²
RFE B2/D2 200-460-60-115-A	Siba 2071332.450 450A 1250V NH 1	AE 150mm ²
RFE B2/D2 230-460-60-115-A	Siba 2071332.500 500A 1100V NH 1	ES 240mm ²

Table 3.6.1.2

REVCON® - type	Max. fuse AC	Connection terminal and max. cross section of the supply line*
RFE B2/D2 30-500-50-230-A	Siba 5014006.80 80A 690V 22x58mm	AE 25mm ²
RFE B2/D2 45-500-50-230-A	Siba 5014006.100 100A 690V 22x58mm	AE 25mm ²
RFE B2/D2 60-500-50-230-A	Siba 5007406.125 125A 690V 22x58mm	AE 25mm ²
RFE B2/D2 80-500-50-230-A	Siba 2018920.160 160A 690V NH 00	AE 50mm ²
RFE B2/D2 100-500-50-230-A	Siba 2018920.200 200A 690V NH 00	AE 50mm ²
RFE B2/D2 125-500-50-230-A	Siba 2018920.315 315A 690V NH 00	AE 50mm ²
RFE B2/D2 150-500-50-230-A	Siba 2018920.315 315A 690V NH 00	AE 50mm ²
RFE B2/D2 200-500-50-230-A	Siba 2071332.450 450A 1250V NH 1	AE 150mm ²
RFE B2/D2 230-500-50-230-A	Siba 2071332.500 500A 1100V NH 1	AE 240mm ²

Table 3.6.1.3

ES ≙ end sleeve for strands

* At the fuse holder respective disconnecter

Technical data

3.6.2 Series fuses REVCON RFE B3/D3

REVCON® - type	Max. fuse AC	Connection terminal and max. cross section of the supply line*
RFE B3/D3 30-400-50-230-A	Siba 5014006.80 80A 690V 22x58mm	AE 25mm ²
RFE B3/D3 45-400-50-230-A	Siba 5007406.125 125A 690V 22x58mm	AE 25mm ²
RFE B3/D3 60-400-50-230-A	Siba 2018920.160 160A 690V NH 00	AE 25mm ²
RFE B3/D3 80-400-50-230-A	Siba 2018920.160 160A 690V NH 00	AE 25mm ²
RFE B3/D3 100-400-50-230-A	Siba 2018920.200 200A 690V NH 00	AE 50mm ²
RFE B3/D3 125-400-50-230-A	Siba 2018920.350 350A 690V NH 00	AE 150mm ²
RFE B3/D3 150-400-50-230-A	Siba 2071332.400 400A 1250V NH 1	AE 150mm ²
RFE B3/D3 200-400-50-230-A	Siba 2071332.500 500A 1100V NH 1	AE 150mm ²
RFE B3/D3 250-400-50-230-A	Siba 2071332.630 630A 1110V NH 1	AE 240mm ²

Table 3.6.2.1

REVCON® - type	Max. fuse AC	Connection terminal and max. cross section of the supply line*
RFE B3/D3 30-460-60-115-A	Siba 5014006.100 100A 690V 22x58mm	AE 25mm ²
RFE B3/D3 45-460-60-115-A	Siba 5007406.125 125A 690V 22x58mm	AE 25mm ²
RFE B3/D3 60-460-60-115-A	Siba 2018920.160 160A 690V NH 00	AE 25mm ²
RFE B3/D3 80-460-60-115-A	Siba 2018920.200 200A 690V NH 00	AE 50mm ²
RFE B3/D3 100-460-60-115-A	Siba 2018920.315 315A 690V NH 00	AE 150mm ²
RFE B3/D3 125-460-60-115-A	Siba 2018920.350 350A 690V NH 00	AE 150mm ²
RFE B3/D3 150-460-60-115-A	Siba 2071332.400 400A 1250V NH 1	AE 150mm ²
RFE B3/D3 200-460-60-115-A	Siba 2071332.450 450A 1250V NH 1	AE 150mm ²
RFE B3/D3 230-460-60-115-A	Siba 2071332.500 500A 1100V NH 1	AE 150mm ²

Table 3.6.2.2

REVCON® - type	Max. fuse AC	Connection terminal and max. cross section of the supply line*
RFE B3/D3 30-500-50-230-A	Siba 5014006.80 80A 690V 22x58mm	AE 25mm ²
RFE B3/D3 45-500-50-230-A	Siba 5014006.100 100A 690V 22x58mm	AE 25mm ²
RFE B3/D3 60-500-50-230-A	Siba 5007406.125 125A 690V 22x58mm	AE 25mm ²
RFE B3/D3 80-500-50-230-A	Siba 2018920.160 160A 690V NH 00	AE 25mm ²
RFE B3/D3 100-500-50-230-A	Siba 2018920.200 200A 690V NH 00	AE 50mm ²
RFE B3/D3 125-500-50-230-A	Siba 2018920.315 315A 690V NH 00	AE 150mm ²
RFE B3/D3 150-500-50-230-A	Siba 2018920.315 315A 690V NH 00	AE 150mm ²
RFE B3/D3 200-500-50-230-A	Siba 2071332.500 500A 1100V NH 1	AE 150mm ²
RFE B3/D3 230-500-50-230-A	Siba 2071332.630 630A 1110V NH 1	AE 150mm ²

Table 3.6.2.3

ES ≙ end sleeve for strands

* At the fuse holder respective disconnecter

3.7 Internal fuses

The power feed/feedback unit is equipped with semiconductor fuses according to the following tables (refer to figure 5.6.1 and 5.7.1 Position 5, figure 5.8.1 und 4.9.1 Position 7, figure 5.10.1 und 5.11.1 Position 9).).

The listed manufacturer is recommended, but naturally also comparative fuses of other manufacturer (e.g. Jean Müller, Ferraz, and Bussmann) are suitable.

Stop!



If semiconductor fuses trip, please get in contact with our company immediately, because possibly further protective measures have tripped. If internal fuses are exchanged, please verify that only the original types are used for replacement.

Danger!



Before replacing a fuse, switch off all voltages!

REVCON RFE B2/D2:

REVCON® - type	DC-fuses (use fast acting semiconductor fuses only)
RFE B2/D2 30-400-50-230-A	Siba 5014006.100 100A 690V 22x58 mm
RFE B2/D2 45-400-50-230-A	Siba 5014206.135 135A 600V 22x58 mm
RFE B2/D2 60-400-50-230-A	Siba 2018920.200 200A 690V NH 00
RFE B2/D2 80-400-50-230-A	Siba 2018920.250 250A 690V NH 00
RFE B2/D2 100-400-50-230-A	Siba 2018920.315 315A 690V NH 00
RFE B2/D2 125-400-50-230-A	Siba 2018920.400 400A 690V NH 00
RFE B2/D2 150-400-50-230-A	Siba 2071332.500 500A 1110V NH 01
RFE B2/D2 200-400-50-230-A	Siba 2071332.630 630A 1110V NH 01
RFE B2/D2 250-400-50-230-A	Siba 2072332.800 800A 1110V NH 02
RFE B2/D2 300-400-50-230-A	Siba 2072332.800 800A 1110V NH 02

Table 3.7.1.1

REVCON® - type	DC-fuses (use fast acting semiconductor fuses only)
RFE B2/D2 30-460-60-115-A	Siba 5014006.100 100A 690V 22x58 mm
RFE B2/D2 45-460-60-115-A	Siba 2018920.125 125A 690V NH 00
RFE B2/D2 60-460-60-115-A	Siba 2018920.160 160A 690V NH 00
RFE B2/D2 80-460-60-115-A	Siba 2018920.200 200A 690V NH 00
RFE B2/D2 100-460-60-115-A	Siba 2018920.250 250A 690V NH 00
RFE B2/D2 125-460-60-115-A	Siba 2018920.350 350A 690V NH 00
RFE B2/D2 150-460-60-115-A	Siba 2018920.400 400A 690V NH 00
RFE B2/D2 200-460-60-115-A	Siba 2071332.500 500A 1110V NH 01
RFE B2/D2 230-460-60-115-A	Siba 2071332.630 630A 1110V NH 01

Table 3.7.1.2

Technical data

REVCON® - type	DC-fuses (use fast acting semiconductor fuses only)
RFE B2/D2 30-500-50-230-A	Siba 5014006.80 80A 690V 22x58 mm
RFE B2/D2 45-500-50-230-A	Siba 5014206.135 135A 600V 22x58 mm
RFE B2/D2 60-500-50-230-A	Siba 2018920.160 160A 690V NH 00
RFE B2/D2 80-500-50-230-A	Siba 2018920.200 200A 690V NH 00
RFE B2/D2 100-500-50-230-A	Siba 2018920.250 250A 690V NH 00
RFE B2/D2 125-500-50-230-A	Siba 2018920.315 315A 690V NH 00
RFE B2/D2 150-500-50-230-A	Siba 2018920.400 400A 690V NH 00
RFE B2/D2 200-500-50-230-A	Siba 2071332.500 500A 1110V NH 01
RFE B2/D2 230-500-50-230-A	Siba 2071332.500 500A 1110V NH 01

Table 3.7.1.3

REVCON RFE B3/D3:

REVCON® - type	DC-fuses (use fast acting semiconductor fuses only)
RFE B3/D3 30-400-50-230-A	Siba 5014006.100 100A 690V 22x58 mm
RFE B3/D3 45-400-50-230-A	Siba 5014206.135 135A 600V 22x58 mm
RFE B3/D3 60-400-50-230-A	Siba 2018920.200 200A 690V NH 00
RFE B3/D3 80-400-50-230-A	Siba 2018920.250 250A 690V NH 00
RFE B3/D3 100-400-50-230-A	Siba 2018920.315 315A 690V NH 00
RFE B3/D3 125-400-50-230-A	Siba 2018920.400 400A 690V NH 00
RFE B3/D3 150-400-50-230-A	Siba 2071332.500 500A 1110V NH 01
RFE B3/D3 200-400-50-230-A	Siba 2071332.630 630A 1110V NH 01
RFE B3/D3 250-400-50-230-A	Siba 2072332.800 800A 1110V NH 02

Table 3.7.2.1

REVCON® - type	DC-fuses (use fast acting semiconductor fuses only)
RFE B3/D3 30-460-60-115-A	Siba 5014006.100 100A 690V 22x58 mm
RFE B3/D3 45-460-60-115-A	Siba 2018920.125 125A 690V NH 00
RFE B3/D3 60-460-60-115-A	Siba 2018920.160 160A 690V NH 00
RFE B3/D3 80-460-60-115-A	Siba 2018920.200 200A 690V NH 00
RFE B3/D3 100-460-60-115-A	Siba 2018920.250 250A 690V NH 00
RFE B3/D3 125-460-60-115-A	Siba 2018920.350 350A 690V NH 00
RFE B3/D3 150-460-60-115-A	Siba 2018920.400 400A 690V NH 00
RFE B3/D3 200-460-60-115-A	Siba 2071332.500 500A 1110V NH 01
RFE B3/D3 230-460-60-115-A	Siba 2071332.630 630A 1110V NH 01

Table 3.7.2.2

REVCON® - type	DC-fuses (use fast acting semiconductor fuses only)
RFE B3/D3 30-500-50-230-A	Siba 5014006.80 80A 690V 22x58 mm
RFE B3/D3 45-500-50-230-A	Siba 5014206.135 135A 600V 22x58 mm
RFE B3/D3 60-500-50-230-A	Siba 2018920.160 160A 690V NH 00
RFE B3/D3 80-500-50-230-A	Siba 2018920.200 200A 690V NH 00
RFE B3/D3 100-500-50-230-A	Siba 2018920.250 250A 690V NH 00
RFE B3/D3 125-500-50-230-A	Siba 2018920.315 315A 690V NH 00
RFE B3/D3 150-500-50-230-A	Siba 2018920.400 400A 690V NH 00
RFE B3/D3 200-500-50-230-A	Siba 2071332.500 500A 1110V NH 01
RFE B3/D3 230-500-50-230-A	Siba 2071332.630 630A 1110V NH 01

Table 3.7.2.3

Technical data

3.8 Switch on current limiter RFE B2/D2

As the REVCON® RFE B2/D2 has got no switch on current limiter (Pre load circuit), it may **exclusively** used in combination with controllers, which are equipped with an internal pre load circuit for their DC-bus capacitors. The maximum value of the switch on current must not exceed the rated values of tables 3.8.1.1 to 3.8.1.3.

REVCON®-Type	Max. switch on current
RFE B2/D2 30-400-50-230-A	80 A
RFE B2/D2 45-400-50-230-A	115 A
RFE B2/D2 60-400-50-230-A	150 A
RFE B2/D2 80-400-50-230-A	200 A
RFE B2/D2 100-400-50-230-A	250 A
RFE B2/D2 125-400-50-230-A	315 A
RFE B2/D2 150-400-50-230-A	375 A
RFE B2/D2 200-400-50-230-A	500 A
RFE B2/D2 250-400-50-230-A	620 A
RFE B2/D2 300-400-50-230-A	720 A

Table 3.8.1.1

REVCON®-Type	Max. switch on current
RFE B2/D2 30-460-60-115-A	65 A
RFE B2/D2 45-460-60-115-A	105 A
RFE B2/D2 60-460-60-115-A	125 A
RFE B2/D2 80-460-60-115-A	200 A
RFE B2/D2 100-460-60-115-A	250 A
RFE B2/D2 125-460-60-115-A	275 A
RFE B2/D2 150-460-60-115-A	325 A
RFE B2/D2 200-460-60-115-A	375 A
RFE B2/D2 230-460-60-115-A	500 A

Table 3.8.1.2

REVCON®-Type	Max. switch on current
RFE B2/D2 30-500-50-230-A	65 A
RFE B2/D2 45-500-50-230-A	105 A
RFE B2/D2 60-500-50-230-A	125 A
RFE B2/D2 80-500-50-230-A	160 A
RFE B2/D2 100-500-50-230-A	200 A
RFE B2/D2 125-500-50-230-A	250 A
RFE B2/D2 150-500-50-230-A	325 A
RFE B2/D2 200-500-50-230-A	375 A
RFE B2/D2 230-500-50-230-A	500 A

Table 3.8.1.3



Danger!

If the switch on current exceeds the rated values, the rectifier diodes are overloaded and the power feed/feedback unit may be damaged.

3.9 DC-bus capacitors

The precharge limiter of the REVCON® RFE B3/D3 is adapted (at a maximum switch-on frequency of 1/min) to the normally used DC-bus capacitance values of the controller. In table 3.9.1.1 the maximum allowed values are listed.

REVCON®-type	Max. DC-bus capacitance
RFE B3/D3 30 - RFE B3/D3 60	8000µF
RFE B3/D3 80 - RFE B3/D3 285	25000µF

Table 3.9.1.1

Danger!



An operation with higher DC-bus capacitance values is allowed after consulting our technical department and corresponding modification of the unit.

Technical data

3.10 RFI-filter

To observe the EMC-rules in accordance with figure 5.6.1 to 5.11.1 a radio frequency interferences filter class A can be preconceived to the REVCON® unit.

3.10.1 RFI-filter REVCON RFE B2/D2

REVCON® - type	Order designation for filter	Case type
RFE B2/D2 30-400-50-230-A	RF-DCoV 30-400	1
RFE B2/D2 45-400-50-230-A	RF-DCoV 45-400	1
RFE B2/D2 60-400-50-230-A	RF-DCoV 60-400	2
RFE B2/D2 80-400-50-230-A	RF-DCoV 80-400	4
RFE B2/D2 100-400-50-230-A	RF-DCoV 100-400	4
RFE B2/D2 125-400-50-230-A	RF-DCoV 125-400	4
RFE B2/D2 150-400-50-230-A	RF-DCoV 150-400	5
RFE B2/D2 200-400-50-230-A	RF-DCoV 200-400	6
RFE B2/D2 250-400-50-230-A	RF-DCoV 250-400	6
RFE B2/D2 300-400-50-230-A	RF-DCoV 300-400	6

Table 3.10.1.1

REVCON® - type	Order designation for filter	Case type
RFE B2/D2 30-460-60-115-A	RF-DCoV 30-460	1
RFE B2/D2 45-460-60-115-A	RF-DCoV 45-460	1
RFE B2/D2 60-460-60-115-A	RF-DCoV 60-460	2
RFE B2/D2 80-460-60-115-A	RF-DCoV 80-460	4
RFE B2/D2 100-460-60-115-A	RF-DCoV 100-460	4
RFE B2/D2 125-460-60-115-A	RF-DCoV 125-460	4
RFE B2/D2 150-460-60-115-A	RF-DCoV 150-460	5
RFE B2/D2 200-460-60-115-A	RF-DCoV 200-460	6
RFE B2/D2 230-460-60-115-A	RF-DCoV 230-460	6

Table 3.10.1.2

REVCON® - type	Order designation for filter	Case type
RFE B2/D2 30-500-50-230-A	RF-DCoV 30-500	1
RFE B2/D2 45-500-50-230-A	RF-DCoV 45-500	1
RFE B2/D2 60-500-50-230-A	RF-DCoV 60-500	2
RFE B2/D2 80-500-50-230-A	RF-DCoV 80-500	4
RFE B2/D2 100-500-50-230-A	RF-DCoV 100-500	4
RFE B2/D2 125-500-50-230-A	RF-DCoV 125-500	4
RFE B2/D2 150-500-50-230-A	RF-DCoV 150-500	4
RFE B2/D2 200-500-50-230-A	RF-DCoV 200-500	6
RFE B2/D2 230-500-50-230-A	On request	On request

Table 3.3.4.3

3.10.2 RFI- filter REVCON RFE B3/D3

REVCON® - type	Order designation for filter	Case type
RFE B3/D3 30-400-50-230-A	RF-DCV 30-400	1
RFE B3/D3 45-400-50-230-A	RF-DCV 45-400	1
RFE B3/D3 60-400-50-230-A	RF-DCV 60-400	2
RFE B3/D3 80-400-50-230-A	RF-DCV 80-400	3
RFE B3/D3 100-400-50-230-A	RF-DCV 100-400	4
RFE B3/D3 125-400-50-230-A	RF-DCV 125-400	4
RFE B3/D3 150-400-50-230-A	RF-DCV 150-400	5
RFE B3/D3 200-400-50-230-A	RF-DCV 200-400	6
RFE B3/D3 250-400-50-230-A	RF-DCV 250-400	6

Table 3.10.2.1

REVCON® - type	Order designation for filter	Case type
RFE B3/D3 30-460-60-115-A	RF-DCV 30-460	1
RFE B3/D3 45-460-60-115-A	RF-DCV 45-460	1
RFE B3/D3 60-460-60-115-A	RF-DCV 60-460	2
RFE B3/D3 80-460-60-115-A	RF-DCV 80-460	4
RFE B3/D3 100-460-60-115-A	RF-DCV 100-460	4
RFE B3/D3 125-460-60-115-A	RF-DCV 125-460	4
RFE B3/D3 150-460-60-115-A	RF-DCV 150-460	4
RFE B3/D3 200-460-60-115-A	RF-DCV 200-460	6
RFE B3/D3 230-460-60-115-A	RF-DCV 230-460	6

Table 3.10.2.2

REVCON® - type	Order designation for filter	Case type
RFE B3/D3 30-500-50-230-A	RF-DCV 30-500	1
RFE B3/D3 45-500-50-230-A	RF-DCV 45-500	1
RFE B3/D3 60-500-50-230-A	RF-DCV 60-500	2
RFE B3/D3 80-500-50-230-A	RF-DCV 80-500	3
RFE B3/D3 100-500-50-230-A	RF-DCV 100-500	3
RFE B3/D3 125-500-50-230-A	RF-DCV 125-500	4
RFE B3/D3 150-500-50-230-A	RF-DCV 150-500	4
RFE B3/D3 200-500-50-230-A	On request	On request
RFE B3/D3 230-500-50-230-A	On request	On request

Table 3.10.2.3

Technical data

3.11 RHF-RA- Module

To decrease the low frequency harmonic back effects to mains a filter module REVCON® RHF-RA can be connected to the power feedback unit according figure 5.6.1 to 5.11.1.

In the tables 3.11.1.1 to 3.11.1.3 the corresponding filter modules are listed for the power feedback unit. Provided that the total harmonic distortion of the unaffected mains voltage THD U is smaller as 2% and the ratio of short circuit power and installed power R_{SCE} is at least 66, the THD I of the mains current of the power feedback unit is reduced to typical 10% (maximal 16%). * Only in connection with option PPB

RHF-RA- Module RFE B2/D2:

REVCON® - type	Ordering code RHF- module	REVCON® - item number	Case type	Fan
RFE B2/D2 30-400-50-230-A	RHF-RA 43-400-50-20-A	25070001	X3	internal
RFE B2/D2 60-400-50-230-A	RHF-RA 86-400-50-20-A	25070010	X5	internal
RFE B2/D2 80-400-50-230-A	RHF-RA 144-400-50-20-A	25070012	X6	internal
RFE B2/D2 100-400-50-230-A	RHF-RA 144-400-50-20-A	25070012	X6	internal
RFE B2/D2 125-400-50-230-A	RHF-RA 180-400-50-20-A	25070013	X6	internal
RFE B3/D3 150-400-50-230-A	RHF-RA 217-400-50-20-A	25070014	X7	internal
RFE B3/D3 200-400-50-230-A	RHF-RA 304-400-50-20-A	25070016	X7	internal
RFE B2/D2 250-400-50-230-A	RHF-RA 380-400-50-20-A	25070018	X7	internal
RFE B2/D2 300-400-50-230-A	RHF-RA 433-400-50-20-A	25070019	X8	internal

Table 3.11.1.1

REVCON® - type	Ordering code RHF- module	REVCON® - item number	Case type	Fan
RFE B2/D2 30-460-60-115-A	RHF-RA 36-460-60-20-A	25070025	X3	internal
RFE B2/D2 45-460-60-115-A	RHF-RA 60-460-60-20-A	25070027	X4	internal
RFE B2/D2 60-460-60-115-A	RHF-RA 73-460-60-20-A	25070028	X4	internal
RFE B2/D2 80-460-60-115-A	RHF-RA 95-460-60-20-A	25070029	X5	internal
RFE B2/D2 100-460-60-115-A	RHF-RA 154-460-60-20-A	25070031	X6	internal
RFE B2/D2 125-460-60-115-A	RHF-RA 154-460-60-20-A	25070031	X6	internal
RFE B2/D2 150-460-60-115-A	RHF-RA 183-460-60-20-A	25070032	X6	internal
RFE B2/D2 200-460-60-115-A	RHF-RA 291-460-60-20-A	25070034	X7	internal
RFE B2/D2 230-460-60-115-A	RHF-RA 291-460-60-20-A	25070034	X7	internal

Table 3.11.1.2

REVCON® - type	Ordering code RHF- module	REVCON® - item number	Case type	Fan
RFE B2/D2 30-500-50-230-A	RHF-RA 36-500-50-20-A	25070084	X4	internal
RFE B2/D2 45-500-50-230-A	RHF-RA 50-500-50-20-A	25070085	X5	internal
RFE B2/D2 60-500-50-230-A	RHF-RA 77-500-50-20-A	25070087	X5	internal
RFE B2/D2 80-500-50-230-A	RHF-RA 109-500-50-20-A	25070089	X6	internal
RFE B2/D2 100-500-50-230-A	RHF-RA 128-500-50-20-A	25070090	X6	internal
RFE B2/D2 125-500-50-230-A	RHF-RA 155-500-50-20-A	25070091	X7	internal
RFE B2/D2 150-500-50-230-A	RHF-RA 197-500-50-20-A	25070092	X7	internal
RFE B2/D2 200-500-50-230-A	RHF-RA 240-500-50-20-A	25070093	X7	internal
RFE B2/D2 230-500-50-230-A	RHF-RA 296-500-50-20-A	25070094	X8	internal

Table 3.11.1.3

RHF-RA Module RFE B3/D3:

REVCON® - type	Ordering code RHF- module	REVCON® - item number	Case type	Fan
RFE B3/D3 30-400-50-230-A	RHF-RA 43-400-50-20-A	25070001	X3	internal
RFE B3/D3 60-400-50-230-A	RHF-RA 86-400-50-20-A	25070010	X5	internal
RFE B3/D3 80-400-50-230-A	RHF-RA 144-400-50-20-A	25070012	X6	internal
RFE B3/D3 100-400-50-230-A	RHF-RA 144-400-50-20-A	25070012	X6	internal
RFE B3/D3 125-400-50-230-A	RHF-RA 180-400-50-20-A	25070013	X6	internal
RFE B3/D3 150-400-50-230-A	RHF-RA 217-400-50-20-A	25070014	X7	internal
RFE B3/D3 200-400-50-230-A	RHF-RA 304-400-50-20-A	25070016	X7	internal
RFE B3/D3 250-400-50-230-A	RHF-RA 380-400-50-20-A	25070018	X7	internal

Table 3.11.1.1

REVCON® - type	Ordering code RHF- module	REVCON® - item number	Case type	Fan
RFE B3/D3 30-460-60-115-A	RHF-RA 36-460-60-20-A	25070025	X3	internal
RFE B3/D3 45-460-60-115-A	RHF-RA 60-460-60-20-A	25070027	X4	internal
RFE B3/D3 60-460-60-115-A	RHF-RA 73-460-60-20-A	25070028	X4	internal
RFE B3/D3 80-460-60-115-A	RHF-RA 95-460-60-20-A	25070029	X5	internal
RFE B3/D3 100-460-60-115-A	RHF-RA 154-460-60-20-A	25070031	X6	internal
RFE B3/D3 125-460-60-115-A	RHF-RA 154-460-60-20-A	25070031	X6	internal
RFE B3/D3 150-460-60-115-A	RHF-RA 183-460-60-20-A	25070032	X6	internal
RFE B3/D3 200-460-60-115-A	RHF-RA 291-460-60-20-A	25070034	X7	internal
RFE B3/D3 230-460-60-115-A	RHF-RA 291-460-60-20-A	25070034	X7	internal

Table 3.11.1.2

REVCON® - type	Ordering code RHF- module	REVCON® - item number	Case type	Fan
RFE B3/D3 30-500-50-230-A	RHF-RA 36-500-50-20-A	25070084	X4	internal
RFE B3/D3 45-500-50-230-A	RHF-RA 50-500-50-20-A	25070085	X5	internal
RFE B3/D3 60-500-50-230-A	RHF-RA 77-500-50-20-A	25070087	X5	internal
RFE B3/D3 80-500-50-230-A	RHF-RA 109-500-50-20-A	25070089	X6	internal
RFE B3/D3 100-500-50-230-A	RHF-RA 128-500-50-20-A	25070090	X6	internal
RFE B3/D3 125-500-50-230-A	RHF-RA 155-500-50-20-A	25070091	X7	internal
RFE B3/D3 150-500-50-230-A	RHF-RA 197-500-50-20-A	25070092	X7	internal
RFE B3/D3 200-500-50-230-A	RHF-RA 240-500-50-20-A	25070093	X7	internal
RFE B3/D3 230-500-50-230-A	RHF-RA 296-500-50-20-A	25070094	X8	internal

Table 3.11.1.3

Installation

4 Installation

4.1 Mechanical installation

Important hints:

- Use the power feed/feedback units as build-in devices only!
- Observe free spaces!
 - Several power feed/feedback units in one cabinet may be installed next to each other without spacing.
 - Keep a horizontal distance of at least 70mm to other components and to the cabinet walls.
 - Keep a vertical distance of at least 150mm to other components and to the cabinet walls.
- Ensure that there are no obstacles in the way of the cooling air input and output.
- If the cooling air is polluted (dust, dirt swirl, grease, aggressive gas) so that the function of the power feed/feedback unit may be impeded
 - Take sufficient countermeasures, e.g. separate cooling air, mounting of air filters, periodical cleaning.
- Do not exceed the ambient temperature permissible during operation.

Provided mounting position

The power feed/feedback unit has been designed for vertical wall mounting ($\pm 15^\circ$) only. Mounting is allowed only on a flat surface without using any kind of spacers. This kind of mounting is necessary to guarantee the right way for the cooling air. A power loss of 3 % from the maximum nominal power rating has to be calculated. Air-temperature may not exceed 40 °C near the unit. Air-in- and air-out-openings at the top and the bottom of the unit may not be concealed by installation materials such as cable ducts or other equipment. Keep a distance of min. 15 cm to the air-in- and air-out-openings and a distance of min. 7 cm to beside mounted parts or cabinet-walls.

4.2 Dimensions

Power feed/feedback unit:

Dimension diagrams:

REVCON[®] - Feed- and feedback unit RFE case type 1/500	
B2/D2 30-400-... to B2/D2 45-400-...	B2/D2 30-460-... to B2/D2 45-460-...
B2/D2 30-500-... to B2/D2 45-500-...	B3/D3 30-400-... to B2/D2 45-400-...
B3/D3 30-460-... und B3/D3 30-500-...	

REVCON[®] - Feed- and feedback unit RFE case type 2/700	
B2/D2 60-400-... to B2/D2 100-400-...	B2/D2 60-460-... to B2/D2 100-460-...
B2/D2 60-500-... to B2/D2 125-500-...	B3/D3 60-400-... to B3/D3 100-400-...
B3/D3 45-460-... to B3/D3 60-460-...	B3/D3 45-500-... to B3/D3 60-500-...

REVCON[®] - Feed- and feedback unit RFE case type 3/800	
B2/D2 125-400-... to B2/D2 200-400-...	B2/D2 125-460-... to B2/D2 230-460-...
B2/D2 150-500-...	B3/D3 125-400-... to B3/D3 200-400-...
B3/D3 80-460-... to B3/D3 230-460-...	B3/D3 80-500-... to B3/D3 150-500-...

REVCON[®] - Feed- and feedback unit RFE case type 3/801	
B2/D2 250-400-...	B2/D2 250-500-...
B3/D3 250-400-...	B3/D3 250-500-... to B3/D3 285-500-...

REVCON[®] - Feed- and feedback unit RFE case type 3/802	
B2/D2 300-400-...	
B3/D3 300-400-...	

2. Enclosure 2/700

Construction 2/700

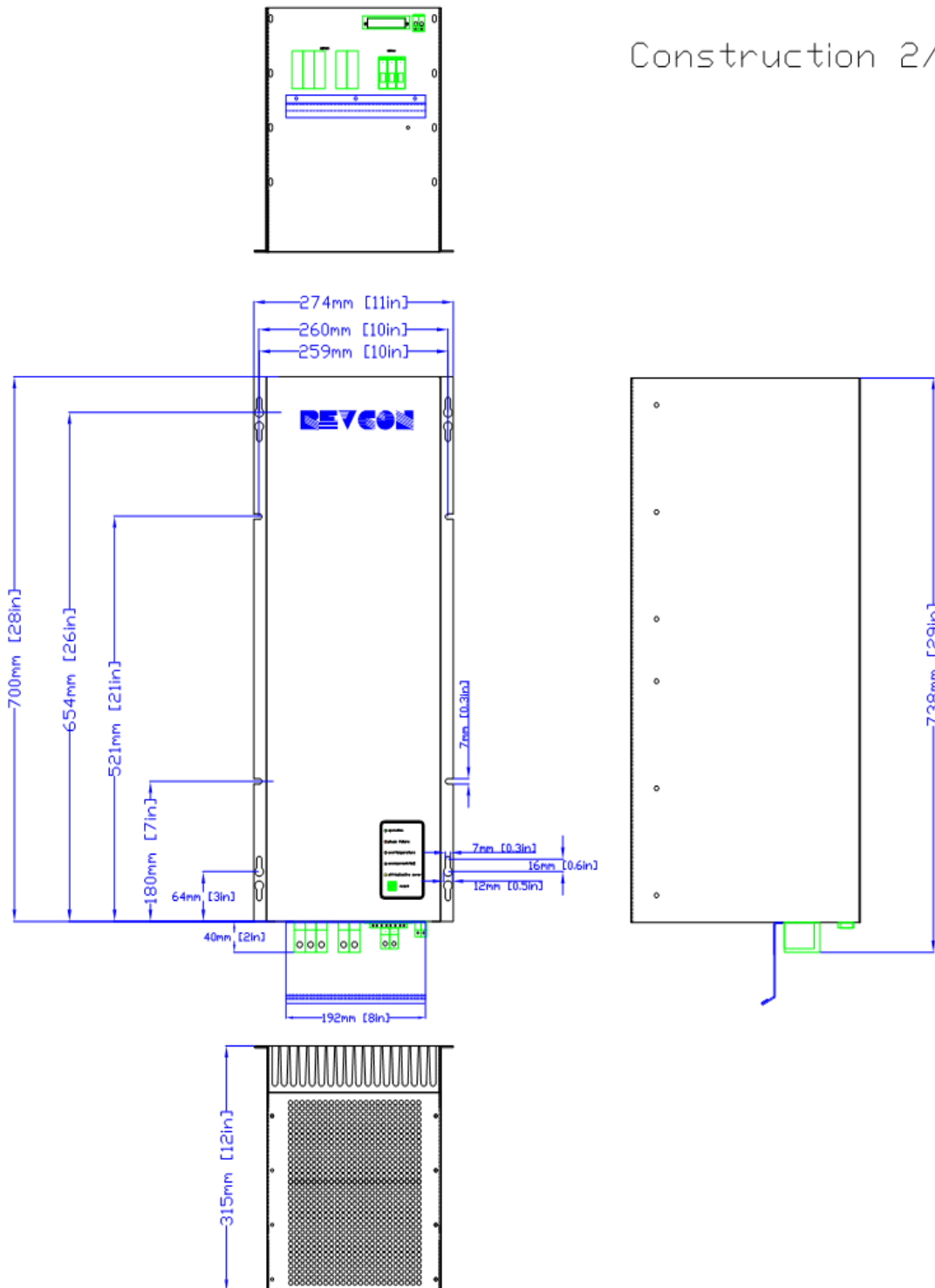

Installation

3. Enclosure 3/800

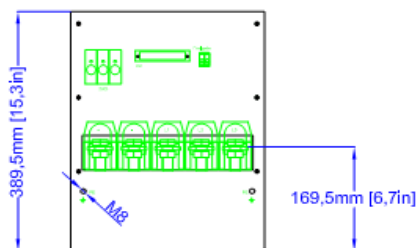

Construction 3/800

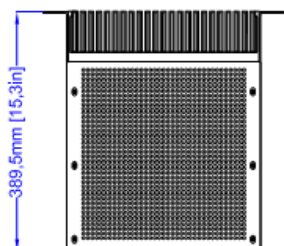
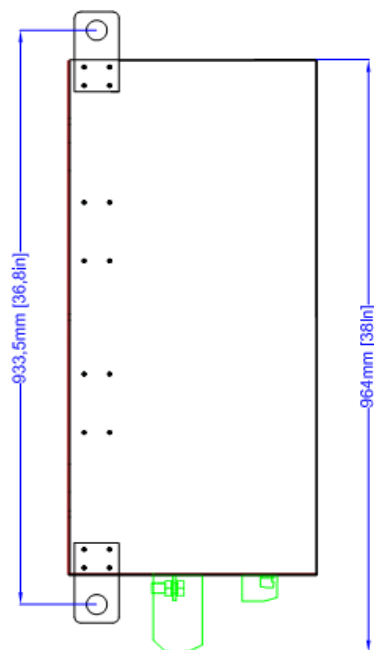
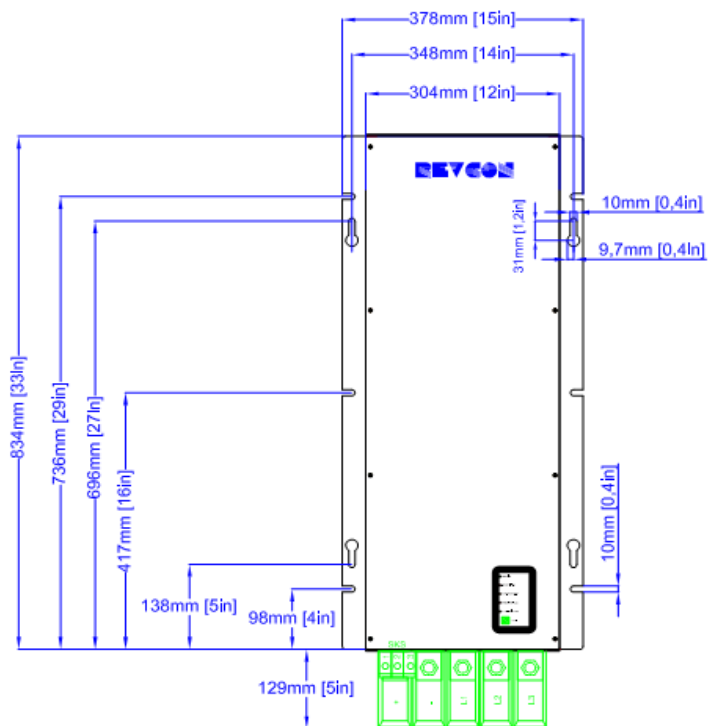

4. Enclosure 3/801

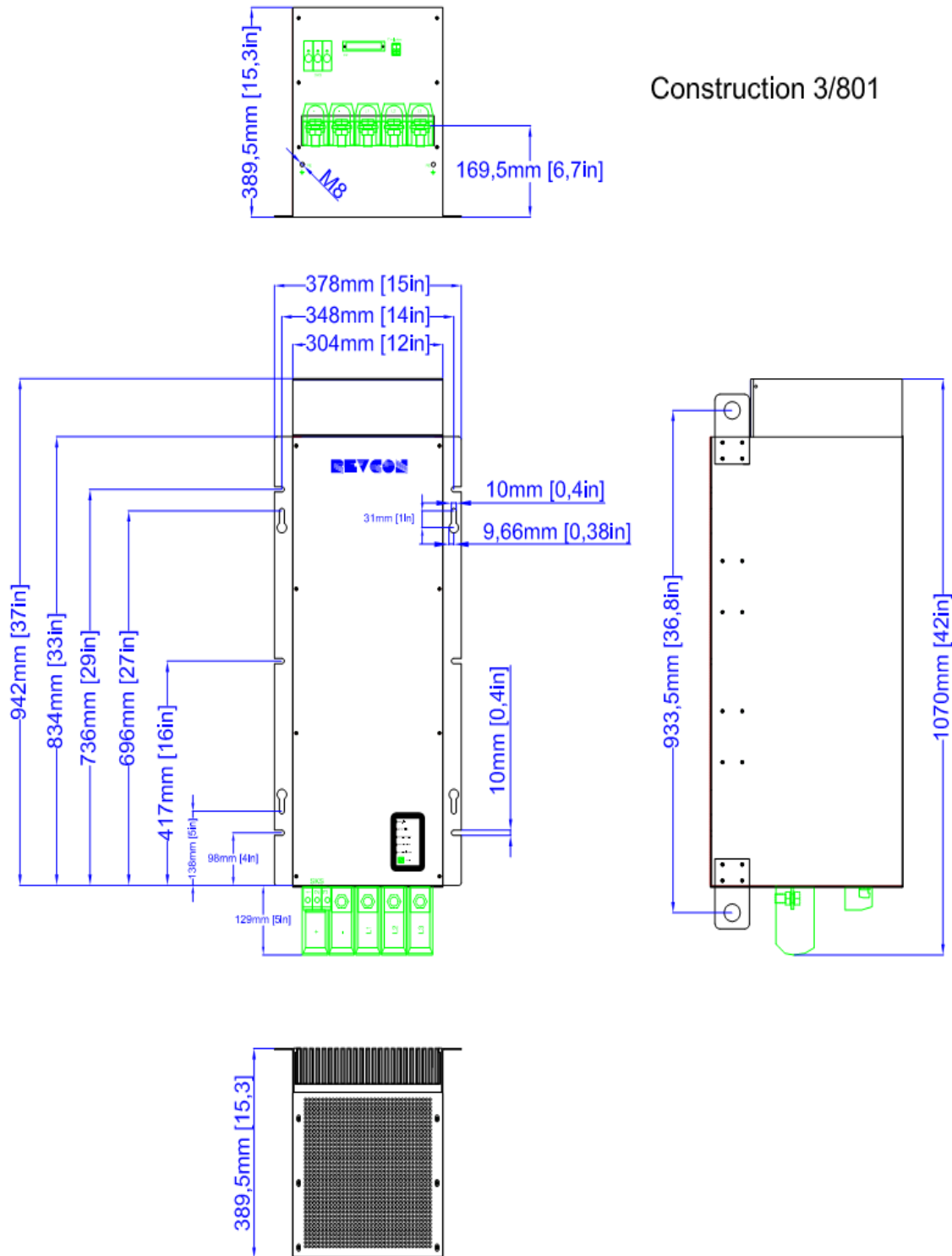

Construction 3/801

Installation

5. Enclosure 3/802

Construction 3/802

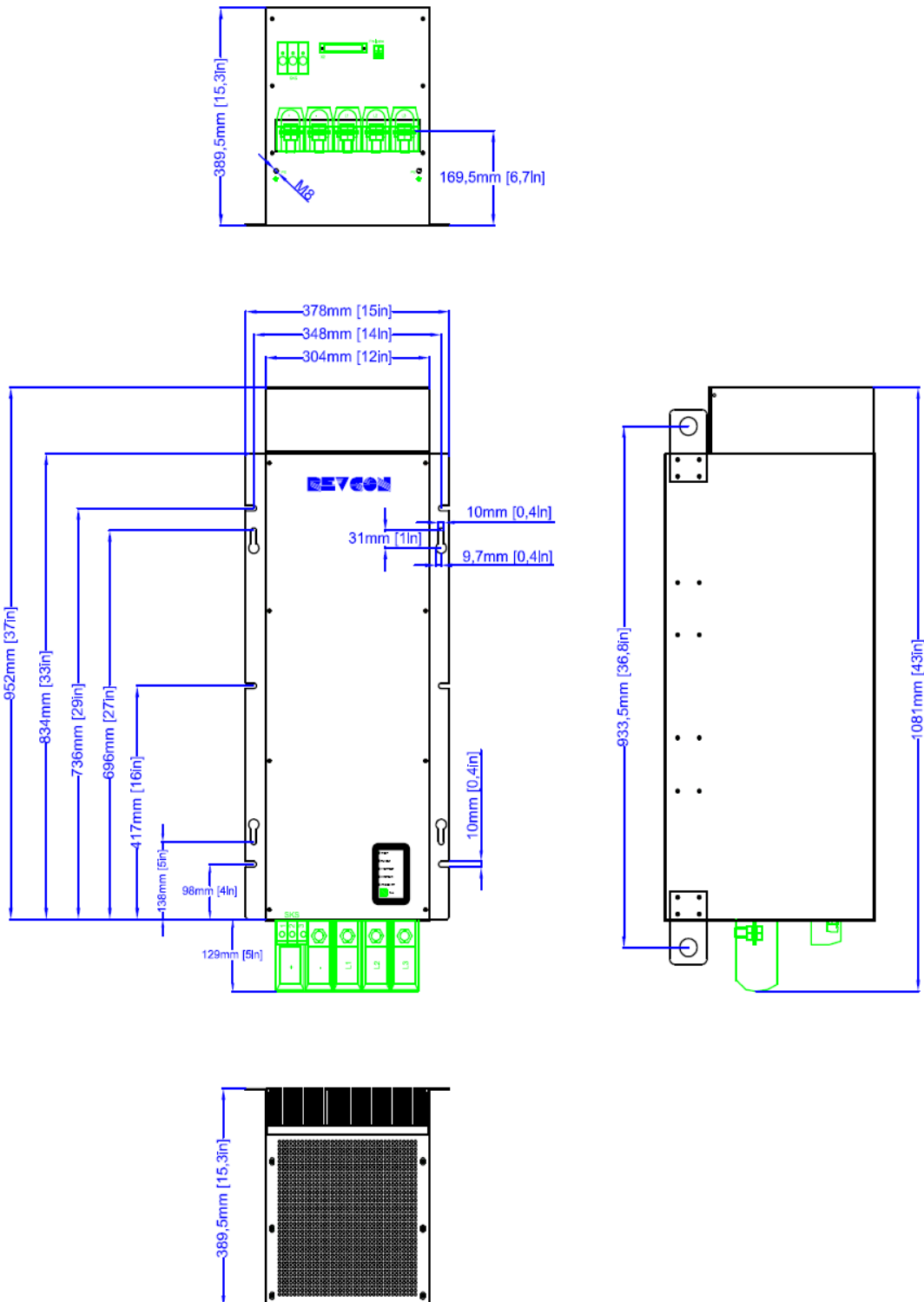

4.3 RHF-Module

Dimensions:

1. Diagram X1

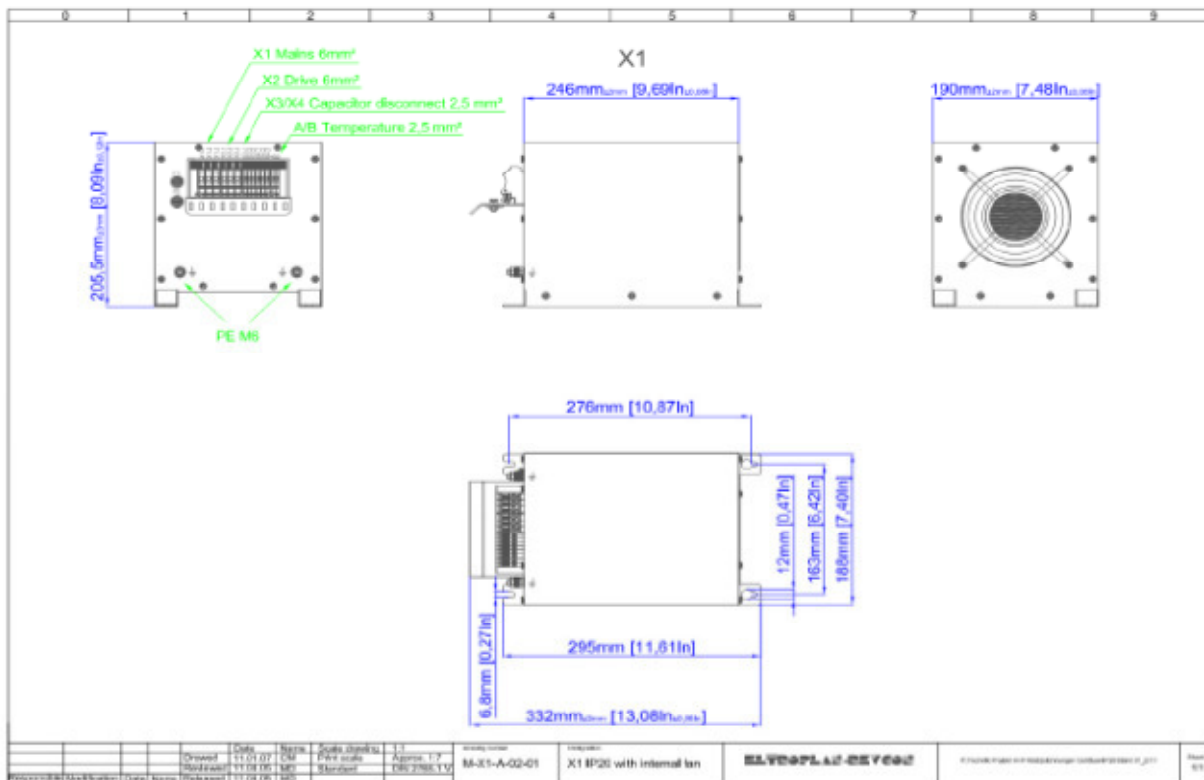

2. Diagram X2

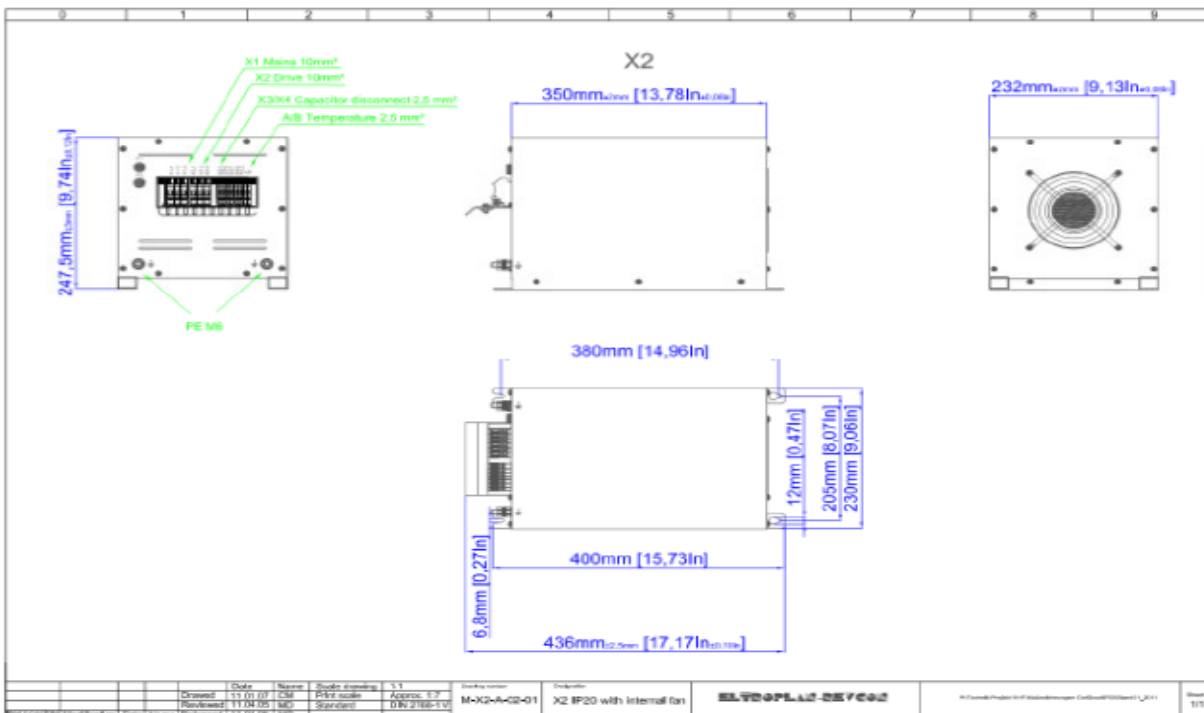

9. Dimension X8: Fan internal

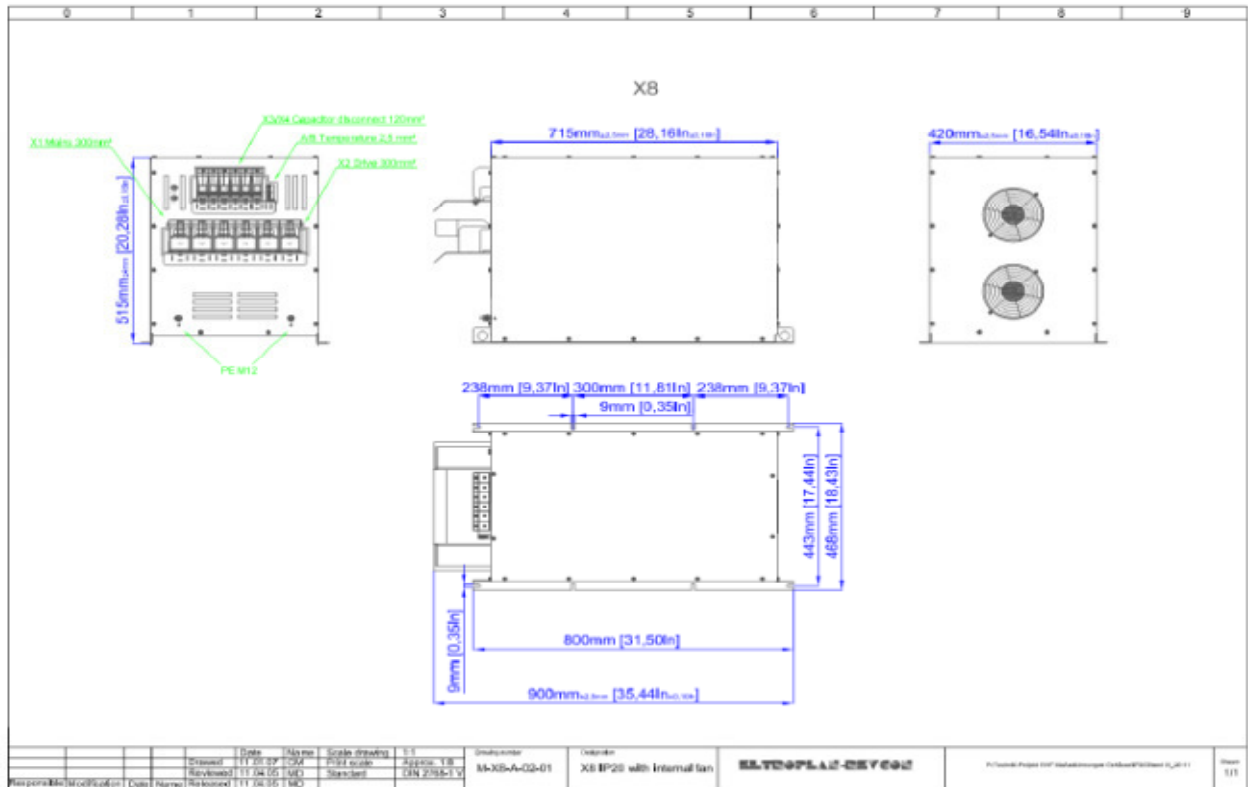

10. Dimension X8: Fan outside

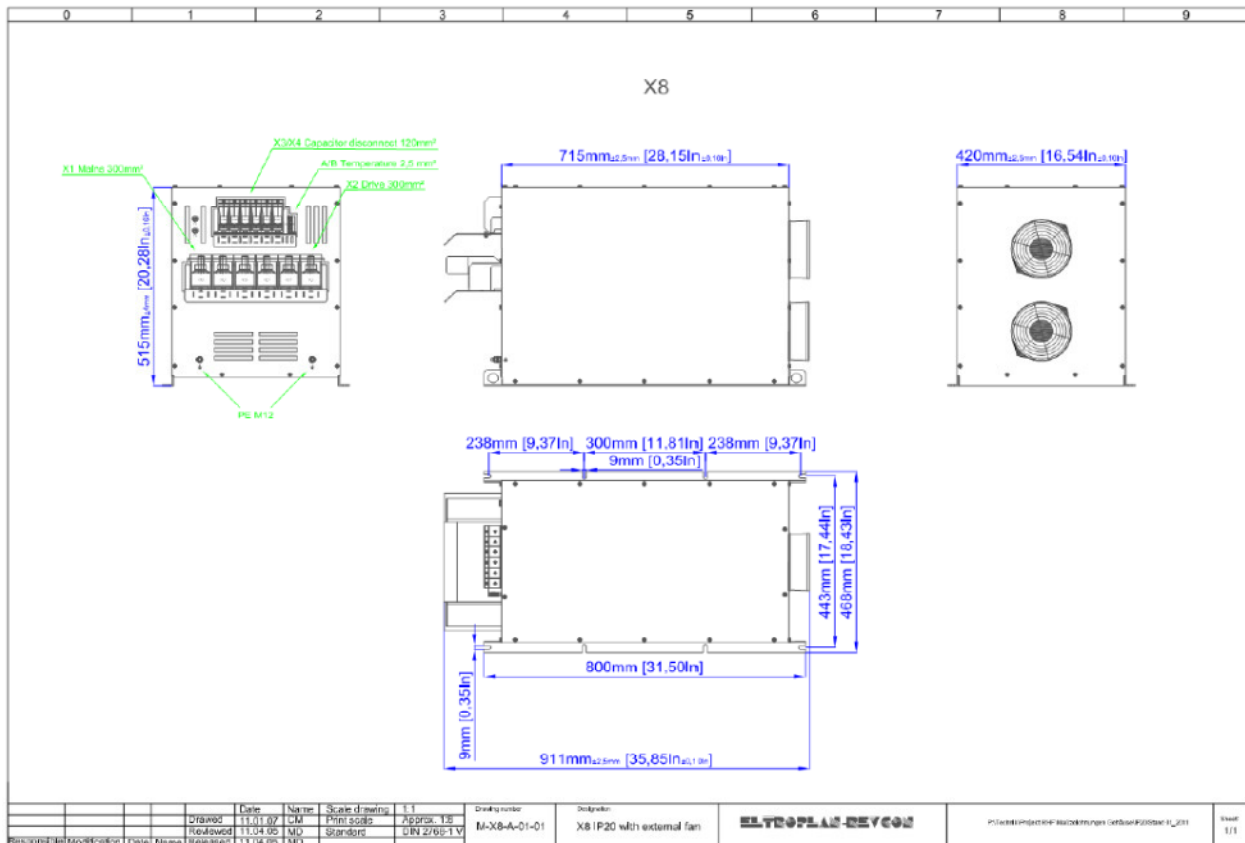

Installation

4.4 RFI-filter

The radio interference filter of case-type 1 and 2 are mounted in footprint-housings, which could be placed between cabinet-wall and power feed/feedback unit.

The radio interference filter of case-type 3 and 4 are mounted in housings, which should be placed beside the power feed/feedback unit.

The power feed/feedback units were fixed with screws M6, the RFI-filter with screws M8.

Dimension diagrams:

1. Diagram Case 1

Interference filter construction 1

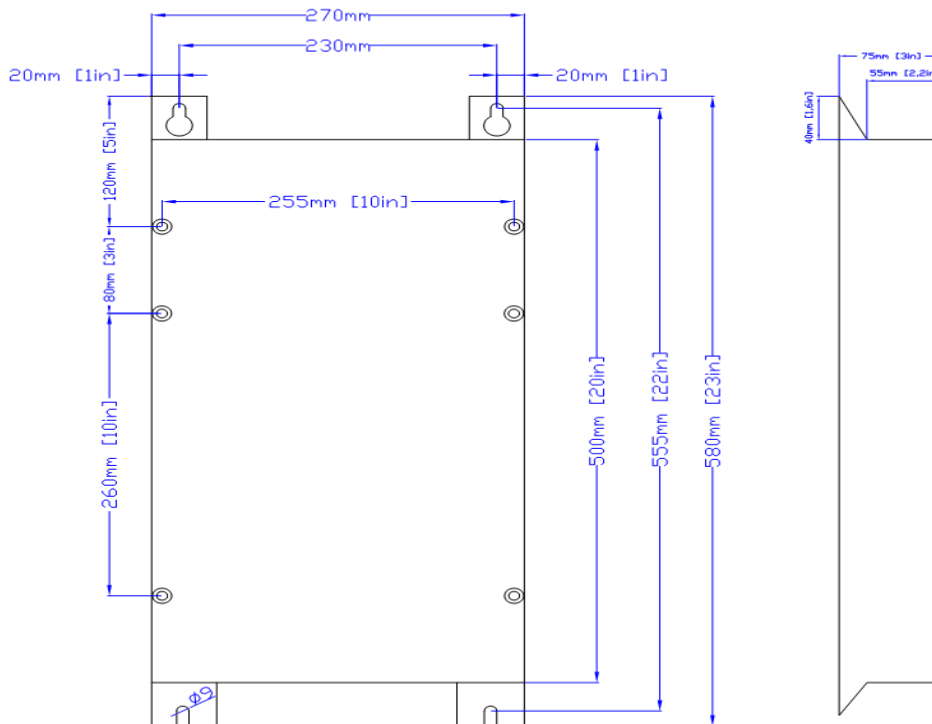

Terminal side (below)

2. Diagram Case 2

Interference filter construction 2

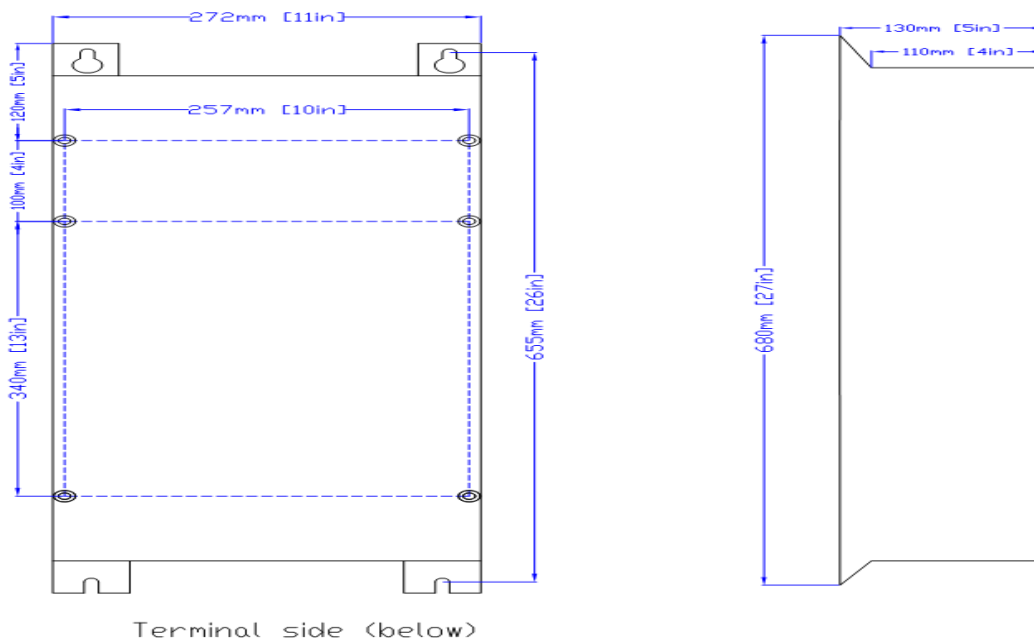

3. Diagram Case 3

Interference filter construction 3

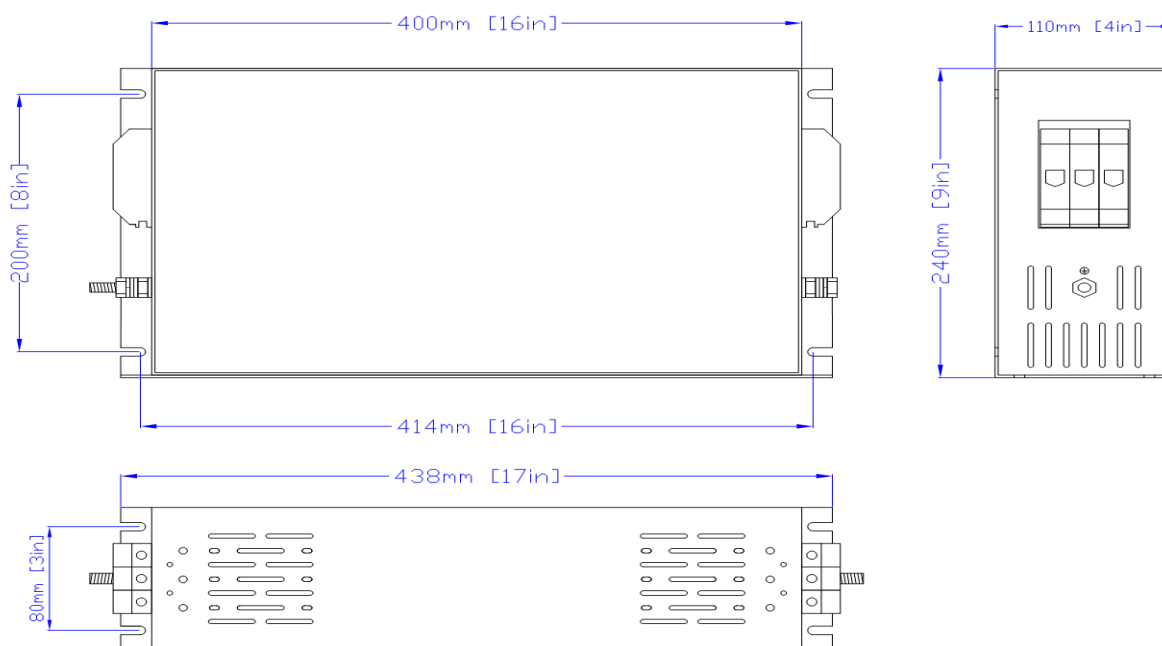

Installation

4. Diagram Case 4

Interference filter construction 4

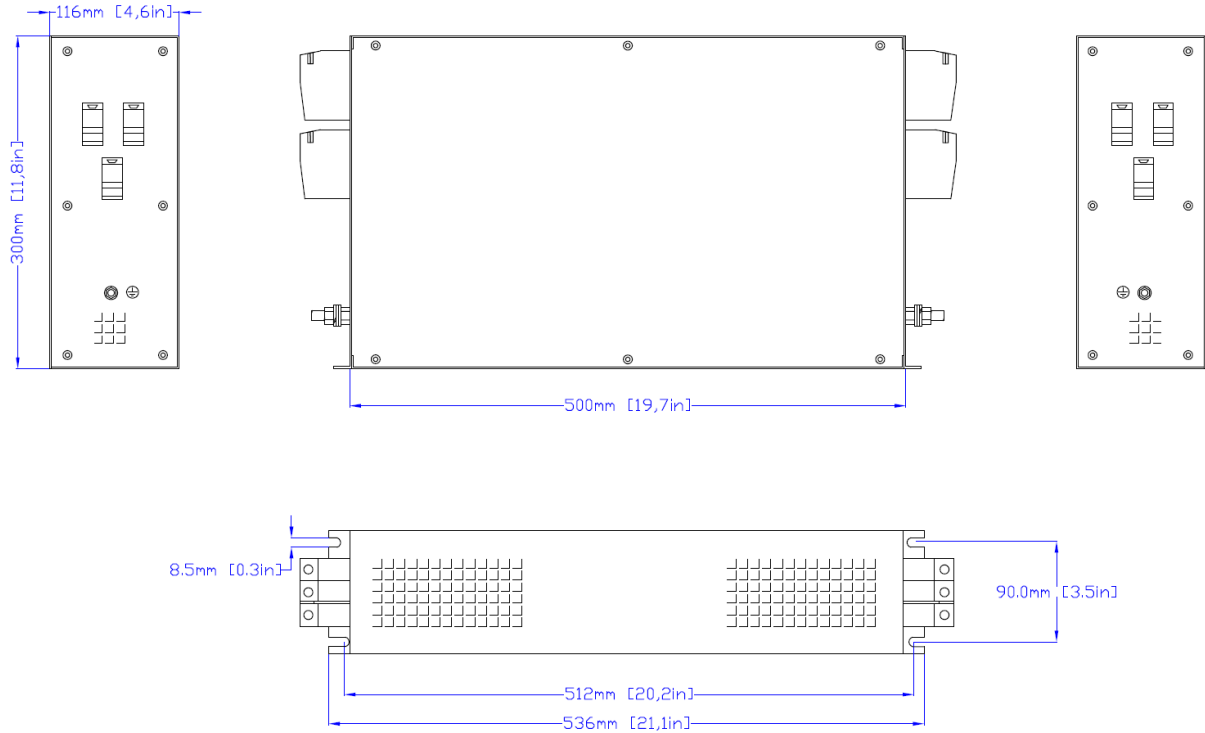

5. Diagram Case 5

Interference filter construction 5

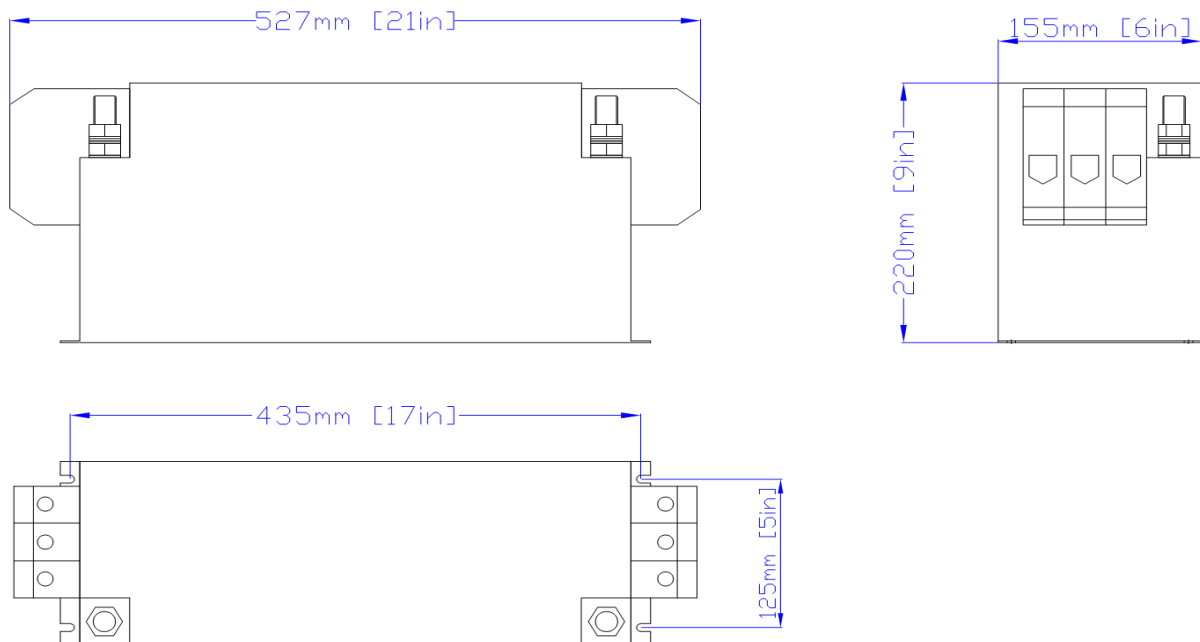

6. Diagram Case 6

Interference filter construction 6

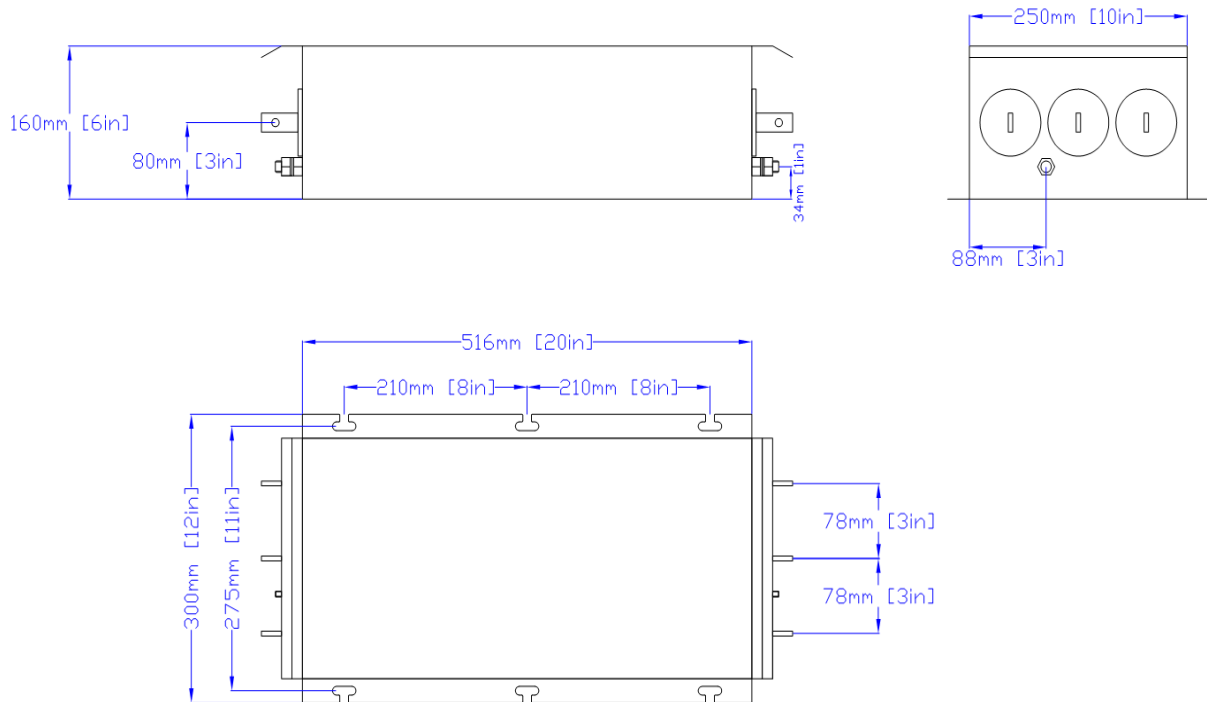

Electrical Installation

5 Electrical installation

5.1 Operator's safety

Danger!



After mains disconnection, the DC-bus terminals of the power feed/feedback unit remain live for several minutes! The exact time, till this voltage has decreased to a not dangerous value is dependent on the used controller and has to run down before any service operations or similar activities are started.

The exact values have to be cross checked with the documentation of the controller.

Replace defective fuses by the regular types (chapter 3.3.3.2) only and without any live voltage.

5.2 Protection of the power feed/feedback unit

Stop!

The power feed/feedback units contain electrostatic sensitive devices (ESSD).



During working at the terminals the personnel has to observe the rules of the international standard IEC 747-1 chapter 9. Basically before starting the works the personnel has to free itself from electrostatic voltages:

Discharge yourself by touching the PE-screw of the housing or another grounded surface in the cabinet.

5.3 Mains types / Mains characteristics

Stop!



Observe the restrictions in accordance to the respective mains type!

If you want to run power feed/feedback units at mains types, which are not listed in the table below please consult our technicians.

VDE conformal mains type	Operation of the power feed/feedback unit	Remark
With grounded star point	Allowed	Observe the technical data of the unit
With isolated star point	After consulting the manufacturer and possible modification of the unit allowed	Observe the technical data of the unit
With grounded active wire	After consulting the manufacturer allowed	Observe the technical data of the unit

Table 4.3.3.1

5.4 Specifications of the used wires

- The used wires have to be compliant with the specifications on site (e.g. UL or UL-c)
- The regulations about the minimum cross section of PE-wires have to be observed!
- The effectiveness of a screened wire is dependent on:
 - a good screen connection
 - low screening impedance:
 - Use screens tin- or nickel-plated copper screens only!
 - the swamp factor of the screen mesh:
 - at least 70% to 80% with a swamp angle of 90°
- Protect the mains wires of the power feed/feedback unit with the provided wire protection fuses.

Electrical Installation

5.5 Connection

The supply line must be connected at the lead-through terminal at the bottom side of the enclosure.

Stop!



At the connection of cable lugs at screws or bolts which lead through conductor rails it must be locked, so that no power permeates into the mounting!

Power connection:

Fusing (also refer to chapter 3.3.4)

- The specifications of chapter 3.3.4 (fuses and wire cross sections) are recommendations and refer to the operation
 - in cabinets and machines
 - installation in cable ducts
 - maximum ambient temperature +40°C.
- When choosing the cross section of the wire the voltage drop under load should be considered (refer to chapter 3.4)
- Protection of the wires at mains side (L1, L2, and L3):
 - by commercial wire protection fuses
 - fuses have to be compliant with the relevant standards on site
 - rated voltage of the fuses have to be compliant with the voltage on site
- Protection of the power feed/feedback unit at mains side (L1, L2, and L3):
 - by commercial semiconductor fuses
 - fuses have to be compliant with the relevant standards on site
 - rated voltage of the fuses have to be compliant with the voltage on site
- Protection of the power feed/feedback unit at DC side (+UG, -UG):
 - fuses are part of the power feed/feedback unit (refer to chapter 3.3.4.2).

The erector/user of the plant bears the responsibility for the observance of further relevant standards (e.g.: VDE 0113, VDE 0289 and so on).

5.5.1 Terminals and connection instructions

1. Example REVCON RFE B2/D2 13-45 kW:

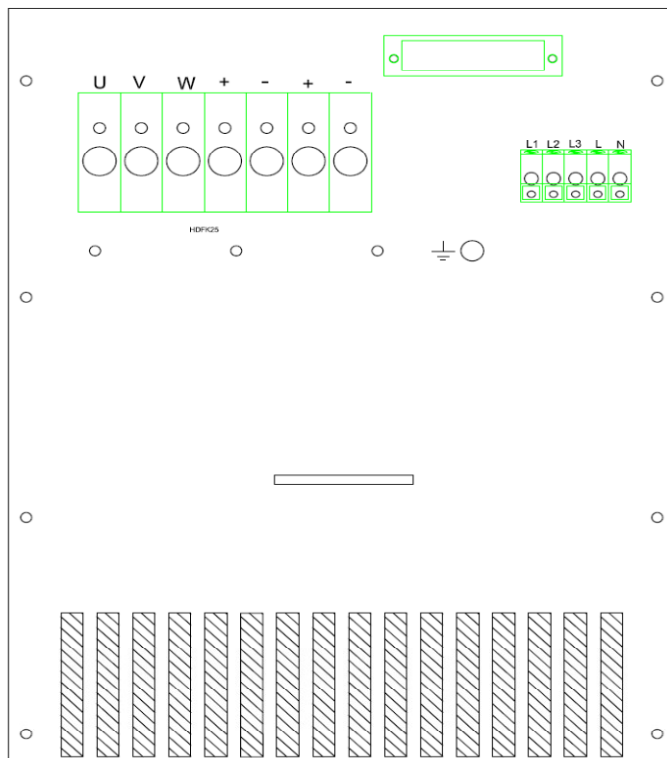

Figure 5.5.1

2. Example REVCON RFE B3/D3 125-200 kW:

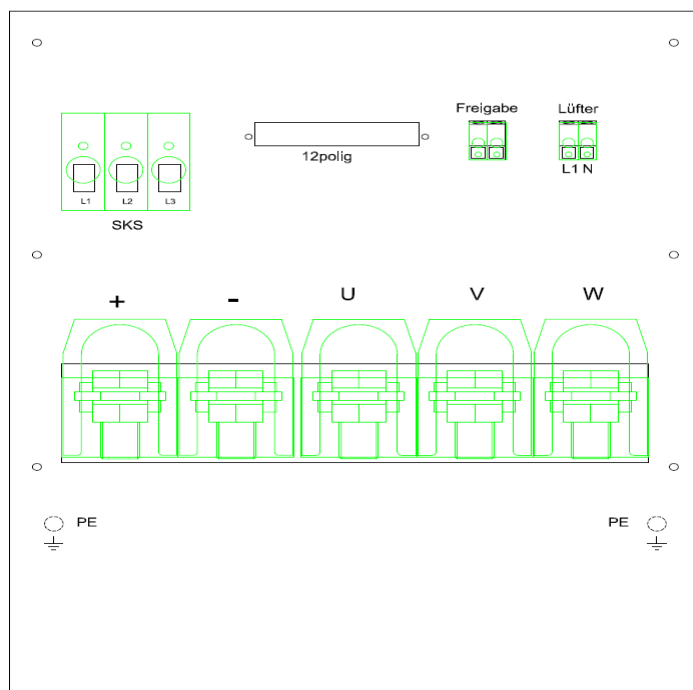

Figure 5.5.2

Electrical Installation

Connection

- All connections should be as short and low-impedance as possible.
- For the observance of the EMC-guideline (in accordance to actual standards like VDE 0160 and EN 50178) screened wires have to be used.
- Connect the mains supply wires at the terminals L1, L2, L3 (at the mains choke) of the power feed/feedback unit. Only three phase connection is allowed.
- A defined phase sequence (clockwise rotation field) must be observed at the main circuit connection of the power unit. The power feed/feedback unit is equipped with a phase-sequence control unit. In case of an incorrect rotation field an error message is displayed via LED as follows: "rotation field failure" or "phase failure". In this case two phases, connected to the power unit, have to be exchanged.
- Connect the protective earth of the supply lines to the earthing screw of the power feed/feedback unit.
- The wires for the DC-bus coupling between controller and power feed/feedback unit have to be connected at the DC-terminals. It is absolutely necessary to observe the correct polarity.

Stop!



An Interchanging of + (PLUS) and – (MINUS) may damage controller and the power feed / feedback unit.

Danger!



It is in no case allowed to pre-connect not current compensated direct inductances!

5.6 Wiring schematic REVCON RFE B2/D2

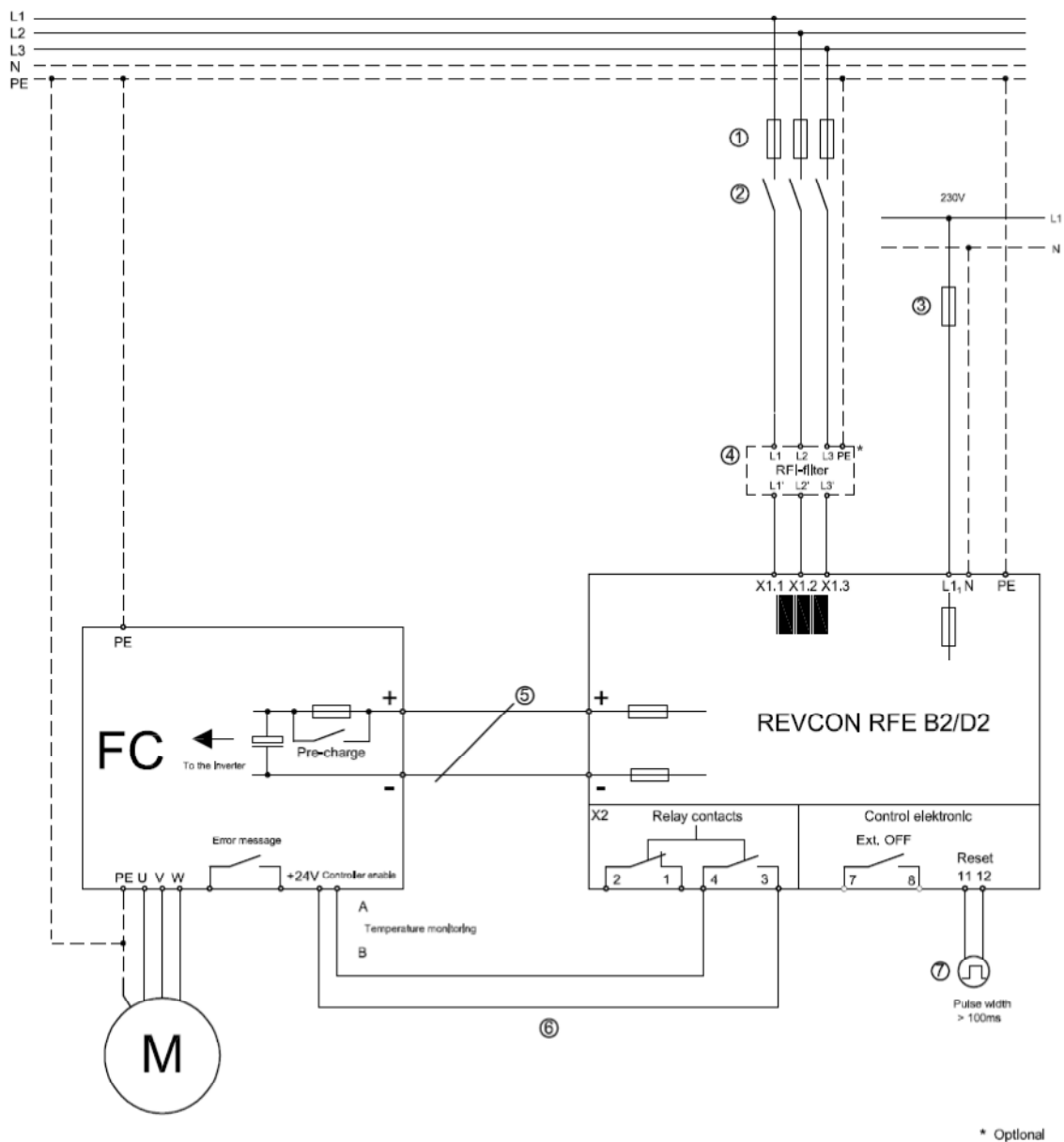

Figure 4.6.1: Wiring schematic of the power feed/feed-back unit REVCON® RFE B2/D2 and one or more controllers

Note!



This is a wiring example. Special features of an application (e.g. installation of a PLC) may require modifications of the wiring of the terminals X2.1 ... X2.12.

Danger!



It is in no case allowed to pre-connect not current compensated direct inductances!

Electrical Installation

Legend for figure 5.6.1 (REVCON[®] RFE B2/D2)

1. Fusing in accordance with controller manual.
2. It is not allowed to connect any other devices except the frequency inverter and the power feed/feedback unit behind the main magnetic switch.

Danger!



If this is not observed, you take the risk that, in the case of switching off the mains during feed-back the power, the voltage in that sector may rise up to a dangerous level. This may destroy the connected devices and perhaps also the inverter and/or the power feed/feedback unit. To avoid such situation, the power feed/feedback unit is equipped with an overvoltage switch off, but nevertheless this hint should be observed!

3. Fusing (230 V supply, <2A current input) in accordance with DIN VDE 0298 or short circuit proof wiring.
4. RFI-filter (optional): Cross section in accordance with the relevant VDE-rules.
5. At these terminals one or more controllers (even with different power ratings) may be attached, like it shown in figure 4.5.1. Even if several controllers are attached, the wires have to be as **short and low impedance** as possible!
6. Optional: The error relay of the feed/feedback unit must be wired (directly or indirectly via a PLC) with the pulse- stop of the controller, to avoid operation of the drive during the capacitor precharge or during an over temperature of the heatsink.

Danger!



If this is not observed, components of the feed/feedback unit will be overloaded and possibly damaged.

7. The possibility of an „ON“ or „RESET“ signal takes place via terminals or 11 and 12: Terminals 11 and 12: Positive pulse (12-24 V DC); practicable e.g. via PLC (terminal 11 +, terminal 12 -).

5.7 Wiring schematic REVCON RFE B3/D3

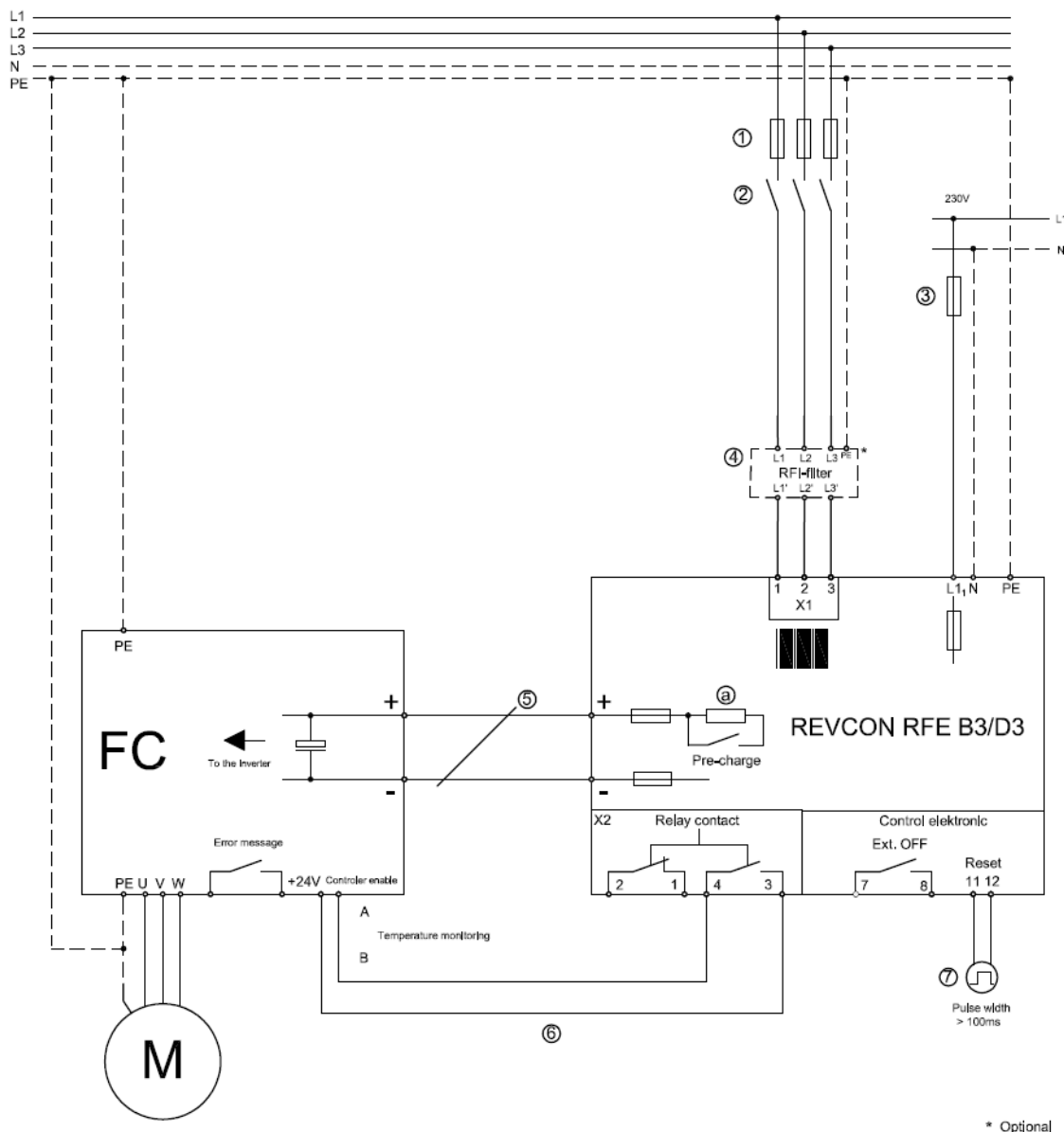

Figure 5.7.1: Wiring schematic of the power feed/feed-back unit REVCON® RFE B3/D3 and one or more controllers

Note!



This is a wiring example. Special features of an application (e.g. installation of a PLC) may require modifications of the wiring of the terminals X2.1 ... X2.12.

Danger!



It is in no case allowed to pre-connect not current compensated direct inductances!

Electrical Installation

Legend for figure 5.7.1 (REVCON[®] RFE B3/D3)

1. Fusing in accordance with controller manual.
2. It is not allowed to connect any other devices except the frequency inverter and the power feed/feedback unit behind the main magnetic switch.

Danger!

If this is not observed, you take the risk that, in the case of switching off the mains during feed-back the power, the voltage in that sector may rise up to a dangerous level. This may destroy the connected devices and perhaps also the inverter and/or the power feed/feedback unit. To avoid such situation, the power feed/feedback unit is equipped with an overvoltage switch off, but nevertheless this hint should be observed!



3. Fusing (230 V supply, <2A current input) in accordance with DIN VDE 0298 or short circuit proof wiring.
4. RFI-filter (optional): Cross section in accordance with the relevant VDE-rules.
5. At these terminals one or more controllers (even with different power ratings) may be attached, like it shown in figure 4.5.1. Even if several controllers are attached, the wires have to be as **short and low impedance** as possible!
6. Optional: The error relay of the feed/feedback unit must be wired (directly or indirectly via a PLC) with the pulse- stop of the controller, to avoid operation of the drive during the capacitor precharge or during an over temperature of the heatsink.

Danger!

If this is not observed, components of the feed/feedback unit will be overloaded and possibly damaged.



7. The possibility of an „ON“ or „RESET“ signal takes place via terminals or 11 and 12: Terminals 11 and 12: Positive pulse (12-24 V DC); practicable e.g. via PLC (terminal 11 +, terminal 12 -).
 - a) REVCON RFE B3/D3: The precharge limiter of the REVCON[®] RFE B3/D3 is adapted (at a maximum switch-on frequency of 1/min) to the normally used DC-bus capacitance values of the controller.

5.8 Wiring schematic REVCON RFE B2/D2 with RHF-RA Module

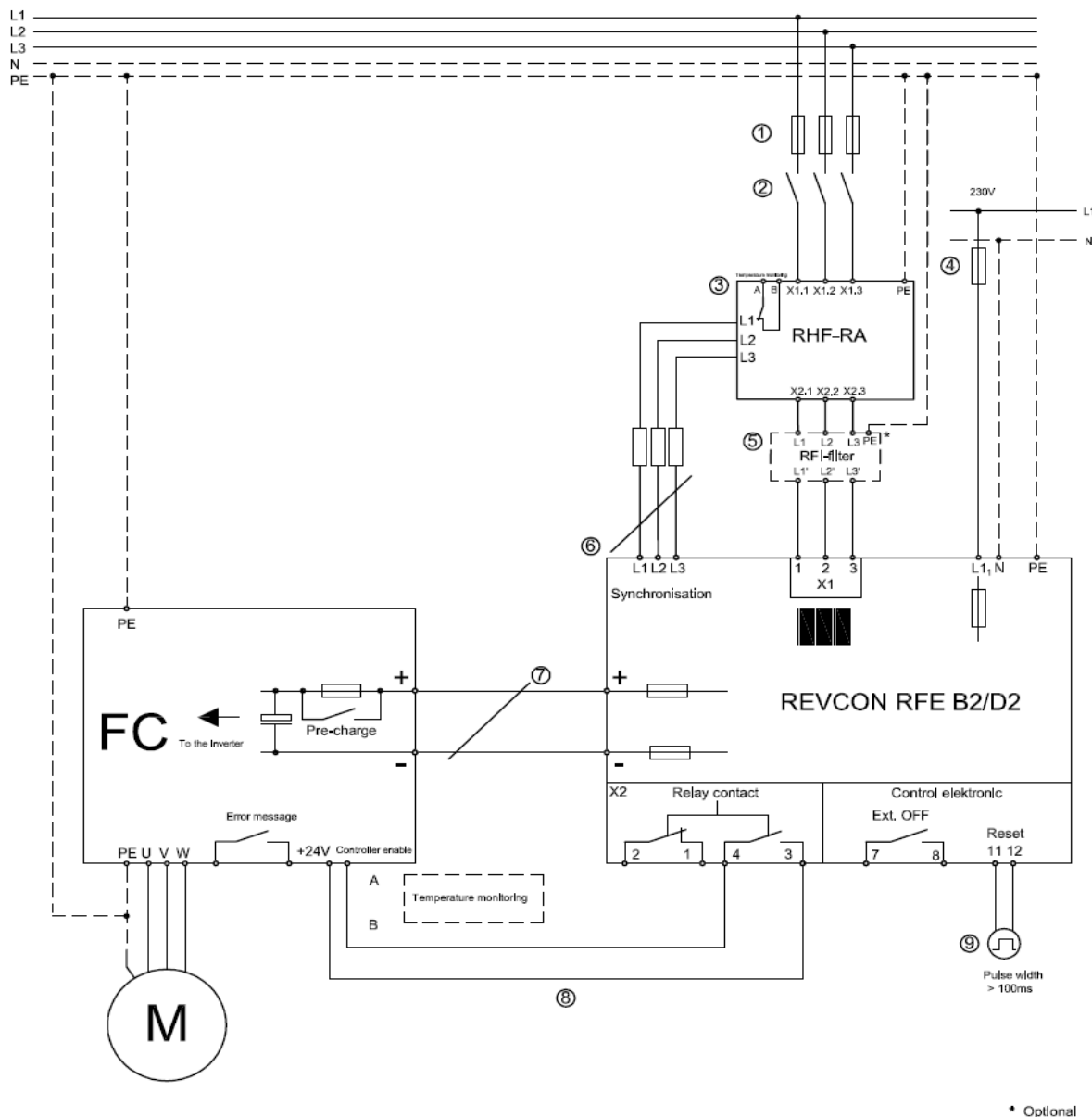

Figure 5.8.1: Wiring schematic of the power feed/feedback unit REVCON® RFE B2/D2 and one or more controllers

Note!



This is a wiring example. Special features of an application (e.g. installation of a PLC) may require modifications of the wiring of the terminals X2.1 ... X2.12.

Danger!



It is in no case allowed to pre-connect not current compensated direct inductances!

Electrical Installation

Legend for figure 5.8.1 (REVCON[®] RFE B2/D2)

1. Fusing in accordance with controller manual.
2. It is not allowed to connect any other devices except the frequency inverter and the power feed/feedback unit behind the main magnetic switch.

Danger!

If this is not observed, you take the risk that, in the case of switching off the mains during feed-back the power, the voltage in that sector may rise up to a dangerous level. This may destroy the connected devices and perhaps also the inverter and/or the power feed/feedback unit. To avoid such situation, the power feed/feedback unit is equipped with an overvoltage switch off, but nevertheless this hint should be observed!



3. RHF-RA Module
4. Fusing (230 V supply, <2A current input) in accordance with DIN VDE 0298 or short circuit proof wiring.
5. RFI-filter (optional): Cross section in accordance with the relevant VDE-rules.
6. Cross section in accordance with the relevant VDE-rules.
7. At these terminals one or more controllers (even with different power ratings) may be attached, like it shown in figure 4.5.1. Even if several controllers are attached, the wires have to be as **short and low impedance** as possible!
8. Optional: The error relay of the feed/feedback unit must be wired (directly or indirectly via a PLC) with the pulse- stop of the controller, to avoid operation of the drive during the capacitor precharge or during an over temperature of the heatsink.

Danger!

If this is not observed, components of the feed/feedback unit will be overloaded and possibly damaged.



9. The possibility of an „ON“ or „RESET“ signal takes place via terminals or 11 and 12: Terminals 11 and 12: Positive pulse (12-24 V DC); practicable e.g. via PLC (terminal 11 +, terminal 12 -).

5.9 Wiring schematic REVCON RFE B3/D3 with RHF-RA Module

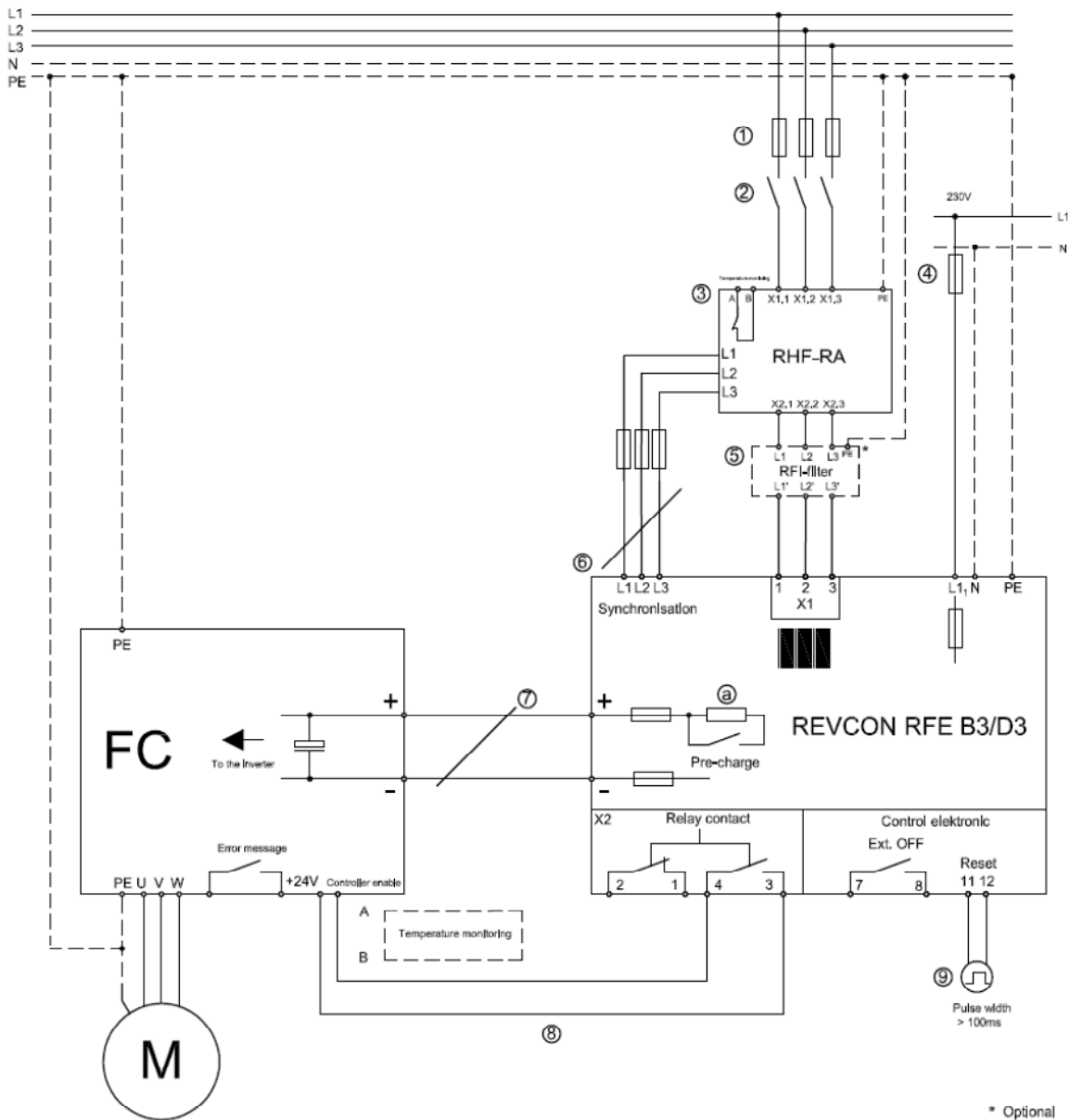

Figure 5.9.1: Wiring schematic of the power feed/feedback unit REVCON® RFE B3/D3 with RHF-RA Module and one or more controllers

Note!



This is a wiring example. Special features of an application (e.g. installation of a PLC) may require modifications of the wiring of the terminals X2.1 ... X2.12.

Danger!



It is in no case allowed to pre-connect not current compensated direct inductances!

Electrical Installation

Legend for figure 5.9.1 (REVCON® RFE B3/D3)

1. Fusing in accordance with controller manual.
2. It is not allowed to connect any other devices except the frequency inverter and the power feed/feedback unit behind the main magnetic switch.

Danger!



If this is not observed, you take the risk that, in the case of switching off the mains during feed-back the power, the voltage in that sector may rise up to a dangerous level. This may destroy the connected devices and perhaps also the inverter and/or the power feed/feedback unit. To avoid such situation, the power feed/feedback unit is equipped with an overvoltage switch off, but nevertheless this hint should be observed!

3. RHF-RA Module
4. Fusing (230 V supply, <2A current input) in accordance with DIN VDE 0298 or short circuit proof wiring.
5. RFI-filter (optional): Cross section in accordance with the relevant VDE-rules.
6. Cross section in accordance with the relevant VDE-rules.
7. At these terminals one or more controllers (even with different power ratings) may be attached, like it shown in figure 4.5.1. Even if several controllers are attached, the wires have to be as **short and low impedance** as possible!
8. Optional: The error relay of the feed/feedback unit must be wired (directly or indirectly via a PLC) with the pulse- stop of the controller, to avoid operation of the drive during the capacitor precharge or during an over temperature of the heatsink.

Danger!



If this is not observed, components of the feed/feedback unit will be overloaded and possibly damaged.

9. The possibility of an „ON“ or „RESET“ signal takes place via terminals or 11 and 12: Terminals 11 and 12: Positive pulse (12-24 V DC); practicable e.g. via PLC (terminal 11 +, terminal 12 -).
 - a) REVCON RFE B3/D3: The precharge limiter of the REVCON® RFE B3/D3 is adapted (at a maximum switch-on frequency of 1/min) to the normally used DC-bus capacitance values of the controller.

6 Control wires

- Connect the control wires to the terminal row X2 at the connection plate of the power feed/feedback unit.
- Don't parallel control wires to interfering power wires.
- Connect the screening of the control wires with an as big as possible surface to the metal cable glands of the flange.

6.1 Control functions

The control terminal strip is placed on the connection plate and is indicated with X2. It is fitted with a plug-in device for easy handling (see figure 4.4.4.2).

The control board must always be designed for the respective main circuit voltage. Therefore the main circuit voltage (230 V, 380 V - 415 V, 440 V - 480 V, 500 V or 690 V) must be declared with every order. This is also necessary for a possible exchange of the device.

From the control terminal strip the operating condition or rather the collective error can be connected to extern. There is also the possibility to execute the external reset or the switch-functions and to connect them with the controller or the PLC.

Electrical Installation

Space diagram of the control board REV 1.4.X

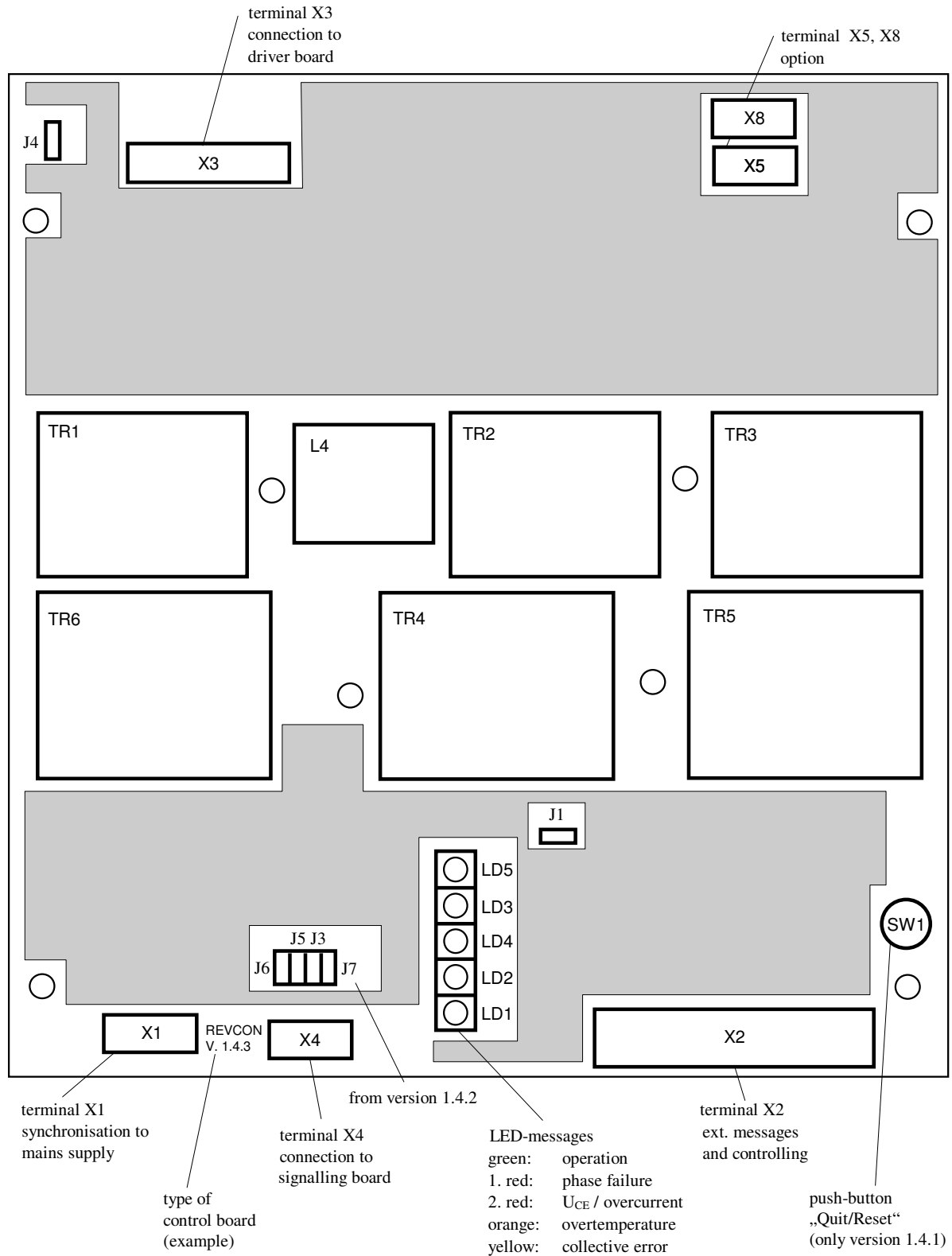

Figure 4.4.4.1

6.2 Control wires REVCON RFE B3/D3 and REVCON RFE B2/D2

Terminal usage:

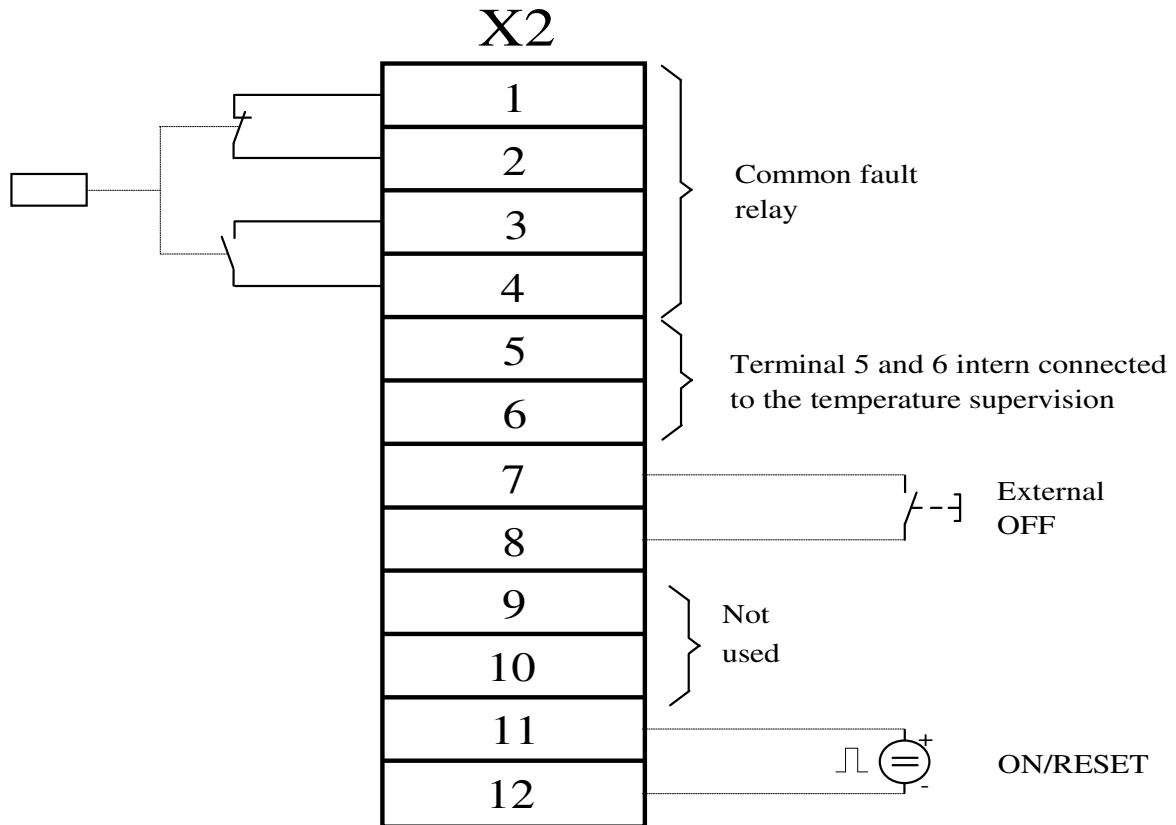

Figure 4.4.4.2

Note!

The terminals 5,6,9 and 10 are not lead through.

Terminals 1-4 (refer to figure 4.4.4.2)

These terminals are contacted to two potential free (SELV) relay contacts (one NOC and one NCC) with a maximum current load of 5 A AC or 3 A DC. It is not allowed to connect other voltage types than SELV!

In figure 4.4.4.2 the relay is displayed in rest position.

The relay toggles, if:

- 1.) Power supply is o.k.
- 2.) No error present, and after perhaps an **ON**-signal has been released.

Electrical Installation



Stop!

To avoid, that the frequency converter accelerate the motor already during the preload, a contact of the error message relay must be integrated into the pulse release of the converter.

If an **OFF**-signal has been released, an collective error is display as the relay toggles.

Terminals 5 and 6

These terminals are already used for the internal temperature supervision of the heat sink.

Terminals 7 and 8

(Use screened wires only, max length)

OFF-signal

These terminals may be used for an external **OFF**-signal (NOC, short time contact) to stop the power feed/feedback unit.



Note!

The OFF-signal stops the feedback operation immediately. If this is done in regen mode, the controller would trip because of too high DC-bus voltage right afterwards.

Terminals 9 and 10

(Not used)

Terminal 11 and 12

(Used screened wires only)

These terminals may be used for an external **ON**-signal (external voltage 12 – 24V DC [e.g. from PLC], short time pulse) to start / reset the power feed/feedback unit.

(Connect „Plus“ to terminal 11, „Minus“ to terminal 12)

6.3 Installation of a power feed/feedback unit in a CE-typical drive-system

General	<ul style="list-style-type: none"> • The user is responsible for the compliance of his application with the EC directives. - If you observe the following measure you can be sure that the drive system will not cause any power-feed/feedback-unit-caused EMC problems, i.e. comply with the EMC Directive when running the machine. - If devices which do not comply with the CE requirement concerning noise immunity EN 500082-2 are operated close to the power feed/feedback unit, these devices may be interfered electromagnetically by the power feed/feedback units.
Assembly	<ul style="list-style-type: none"> • Connect the power feed/feedback unit and the RFI-filter to the grounded mounting plate with a wire of large cross section as possible: <ul style="list-style-type: none"> – Mounting plates with conductive surfaces (zinc-coated or stainless steel) allow permanent contact. – Varnished boards should not be used for installation in accordance with EMC. • If you use several mounting plates: <ul style="list-style-type: none"> – Connect as much surface of the mounting plates as possible (e.g. with copper bands) • Ensure the separation of power and control cables. • Cable guides as close as possible to the reference potential. Unguided cables have the same effect as aerials.
Filters	<ul style="list-style-type: none"> • Use RFI filters which are assigned to the power feed/feedback unit. RFI filters reduce impermissible high frequency interference to a permissible value.
Screening	<ul style="list-style-type: none"> • Metallic cable glands ensure a big-surface connection between screen and housing • If the screened wire are interrupted at relays or terminals: <ul style="list-style-type: none"> - Connect the screens of the wires with a big surface to the mounting plate. • If the mains wires between RFI-filter and power feed/feedback unit are longer than 300mm: <ul style="list-style-type: none"> - Use screened mains wires - Connect the screen direct at the controller / power feed/feedback unit and at the RFI-filter to the mounting plate. • Screen the control wires: <ul style="list-style-type: none"> - Connect the screens on the shortest possible way to their terminals.
Earthing	<ul style="list-style-type: none"> • All metallic conduction components (power feed/feedback unit, controller, RFI-filter) have to be connected to one common earthing point (PE-bus bar). • Observe the in the safety guidelines defined minimum cross sections: <ul style="list-style-type: none"> - For EMC not the cross section, but the surface of a wire and the contact to the mounting plate is important for the function.

Electrical Installation

Power feed/feedback units are electrical units for usage in industrial and commercial plants. In accordance with the EMC guideline 2004/108/EG, it is not obligate to mark these units, as in the sense of the EMC guideline and the EMC law they are components to be mounted by a competent electromechanical engineer and cannot be used stand alone. The proof of the observance of the protective aims of the EMC guideline has to be carried out by the erector / user of the machine / plant. If the by ELTROPLAN-REVCON released RFI-filters are used and the following measures and installation guidelines are observed, the adherence to the prescribed data is cleared.

In combination with the related RFI-filter the power feed/feedback unit has been designed for the usage in ambients of the limit class „A“ („B“ on request).

Definition in accordance with basic standard:

- Electromagnetic compatibility (EMC) - Part 6-4: EN 61000-6-4 and IEC 61000-6-4:2006 Generic standards-Emission standard for industrial environments.
- Electromagnetic compatibility (EMC) - Part 6-2: EN 61000-6-2 and IEC 61000-6-2 Generic standards- Immunity for industrial environments.

7 Installation

Appropriate design of pant and cabinet:

To avoid noise incoupling lay

- a) mains/supply wires
- b) motor wires of controllers / servo amplifiers
- c) control- and data wires (small voltage range < 48 V) with a distance of at least 15 cm between each other.

To obtain low resistive HF-connections, grounding, screening and other metallic connections (e. g. mounting plates, mounted units) have to be done with an as big as possible surface to metallic ground. Use grounding and potential equalisation wires with as big cross section as possible (min. 10mm²) or thick grounding tapes.

Use copper or tinned copper screened wires only, as steel screened wires are not suitable for high frequency applications. Connect the screen with metal clamps or metal glands to the equalisation bars or PE-connections. Don't longer the screen with single wires!

If external RFI-filters are use, these have to be mounted not more than 30cm away from the noise source and with a very good, low resistive based contact.

Inductive switching units (relay, magnetic contactor and so on) have to be equipped with varistors, RC-circuits or suppressor diodes always.

All connections have to be as short as possible and must lay as close to the ground potential as possible, as free hovering wires act like aerials.

Avoid wire loops in all wires. Connect unused wires to ground at both ends.

If unscreened wires are used, twist the pairs to attenuate unsymmetrical noise.

Installation

7.1 Connection of a RFI-filter

The following figure shows mounting and connection of an external RFI-filter.

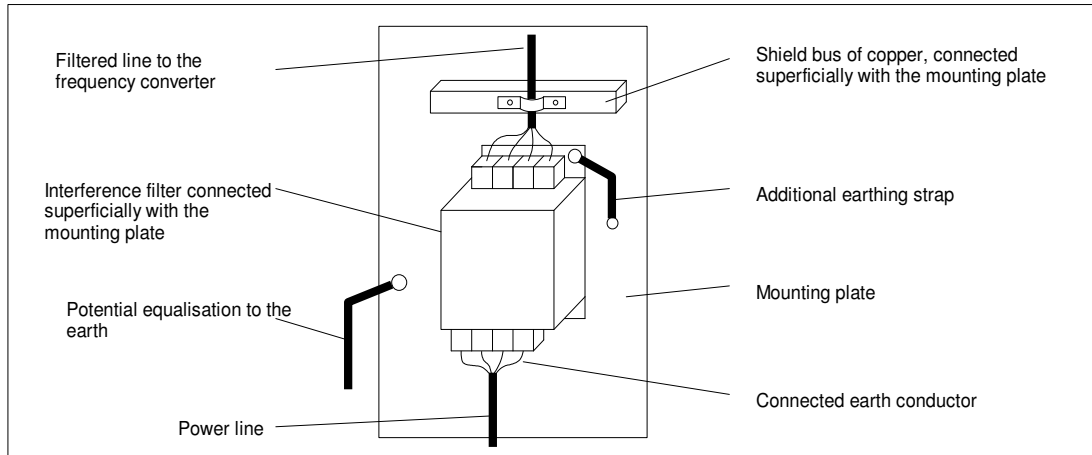

7.2 Design of an EMC-conformal cabinet

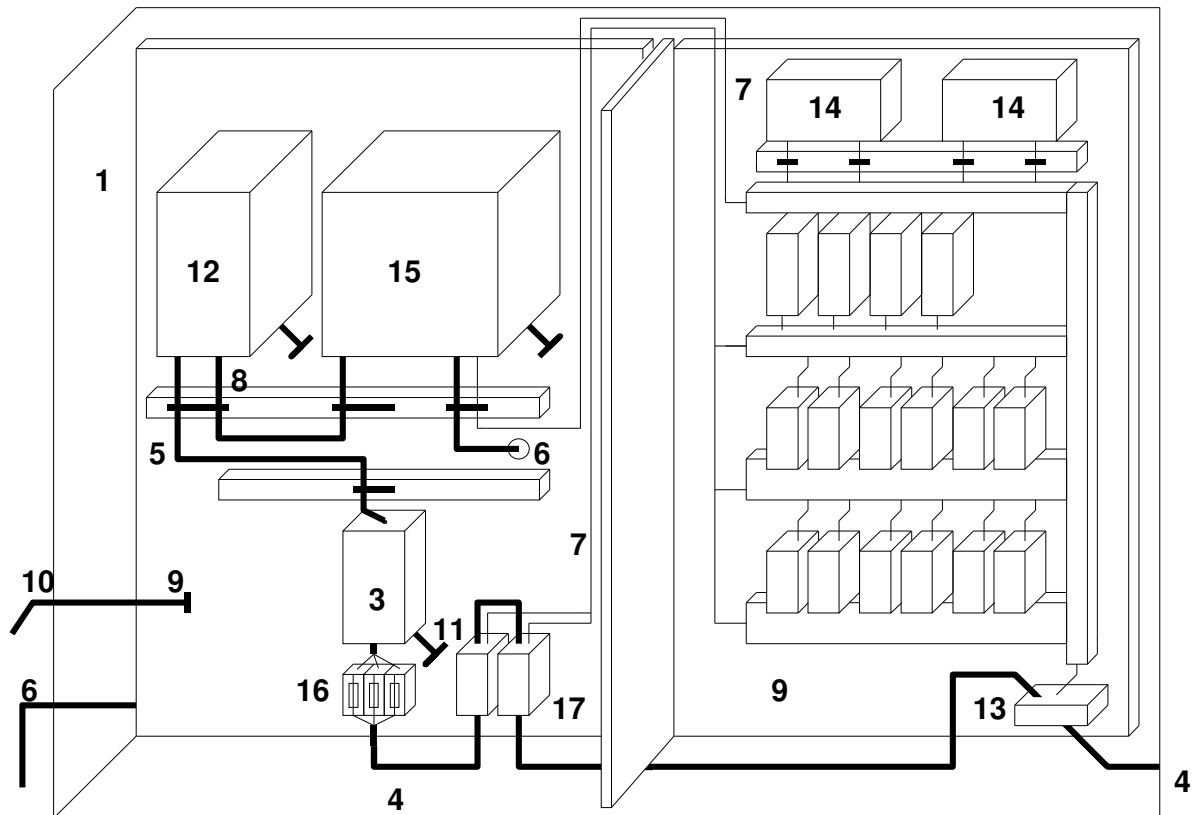

- | | |
|---|---|
| 1. Cabinet unit (DC) | 8. DC-bus wiring with power feed/feedback |
| 2. - | |
| 3. RFI-filter | 9. Mounting plate (common star point) |
| 4. Mains supply wire | 10. Potential equalisation |
| 5. Wiring between RFI-filter
and power feed/feedback unit:
Cross section in accordance with fusing
or short circuit proof! | 11. Additional earthing wire |
| 6. Motor wiring | 12. Power feed/feedback unit |
| 7. Control wiring | 13. Mains connection |
| | 14. PLC |
| | 15. Controller |
| | 16. Mains fuses |
| | 17. Mains magnetic switch |

Installation

Remarks:

Generally a system should be divided in an area for power electronics and an area for control electronics. This is not only important, if the system is mounted in one cabinet, but even also if it is spread over several cabinets. As of the strong noise emission of the power wires it is recommended to mount a screening wall. This wall must have a low resistive contact to the frame or the mounting plate (remove lacquer!).

The installed power feed/feedback unit and the connected RFI-filter must form an integrated whole, i.e. they have to be connected via the mounting plate without an isolating lacquer.

The connection wire between power feed/feedback unit and RFI-filter must be screened. At both ends the screen has to be connected to ground. The wire should not be longer than 300mm.

The mounting plate of the power feed/feedback unit should be the star point for the whole grounding and screening of the machine or plant. If the drive or other components of the plant cause interference, the HF connection of these components is bad. This could be improved by an additional potential equalisation.

By using RFI-filters the leakage current is increased. As the leakage current is higher than 3,5 mA, one of the following conditions must be fulfilled:

- Cross section of the protective wire must be at least 10 mm² CU.
- Supervision of the protective wire by an module, which trips in case of an fault.
- Install a second wire in parallel to the protective wire via separate terminals. This wire must be conformal with VDE 0100 / part 540.

7.3 Installation of control wires

The screen of digital signal wires, which are not connected to terminals, has to be connected to the screen bars to decrease the impedance of the screen.

The screen of digital signal wires, which are connected to terminals, has to be connected with as big surface as possible to ground.

If the screen is grounded via a single wire, the noise discharge is getting worse by 70%.

For screen connection commercial cable clamps are suitable.

If unscreened signal wires are used, install only twisted pair wires.

Commissioning

8 Commissioning



Danger!

Prior to initial switch-on of the power feed/feedback unit check the wiring for completeness, short-circuit and earth fault.



Danger!

If the wiring is not correct, a non-intended operation of controller and/or power feed/feedback unit is possible.

8.1 First powering up

1. Switch on mains supply :
 - The power feed/feedback unit is ready for operation after ca. 1s
2. Check the readiness for service of the power feed/feedback unit:
 - If only the green LED is on: Power feed/feedback unit is ready for service.
 - If beside the green LED also other LED's are on:
A disturbance is present. Before proceeding with commissioning, remove the disturbance (refer to chapter 7 "Troubleshooting").
3. Check the readiness for service of the controller:
 - Proceed in accordance with the controller manual.

8.2 Configuration

The coding of the jumpers enables different driving possibilities and different internal functions in accordance to specific error messages.

In the following different definitions are explained which result from the specific possibilities of coding!

a) „Autostart“

Autostart means that the device is starting with a delay-time of about 1 sec. after connecting mains voltage automatically ("automatically switch-on").

Coding via jumper, see figure 4.4.4.1:

J1 closed: Autostart

If the unit should not start automatically despite the phase failure control is disabled, during the switch on process the terminals 7 and 8 have to be bridged till 4 s after switching on. To start the feedback operation afterwards a short impulse has to be given on the RESET input.

b) „Switch on“ - „Switch off“

„Switch off“ means that the driving of the semiconductors and the power feed/feedback will be interrupted. A braking operation of the frequency inverter with power feed/feedback is no longer possible.

„Switch-on“ is the activation of driving the semiconductors.

c) „Storage“

The unit is equipped with an error storage where special failures can be assigned to. Stored error messages have to be confirmed by RESET or interruption of mains supply. "Storage" always leads to a "switch-off" and to a collective-error-relay tripping.

Configuration

d) Reset

After the failure is removed, a stored error has to be reset by pushing the RESET-button or rather by switching-off and on again the main circuit voltage (3-ph.)

Stop!



A reset in case of too high DC-bus voltage during the braking operation is not recommended. If it is done nevertheless, the power semiconductors are exposed to increased stress, which may lead to accelerated aging.

e) „Phase failure“

The phase-failure-supervision monitors the mains supply in all 3 phases.

In case of a breakdown of one phase the unit stays still in function, but with reduced feed/feedback power.

The power feed/feedback unit reacts in different ways on phase failures. One possibility is the "2 phase operation", the other one let the system get out of operation and the collective-error-relay signals the failure.

Coding via jumper, see figure 4.4.4.1.1:

J3	J5	J6	J7	Phase-failure-supervision		
—	0	0	—	Sensitive, error storage "ON"	0	Jumper open
—	—	—	—	Insensitive, error storage "ON"	—	Jumper closed
0	X	X	—	Off, but error storage "ON"	X	Jumper random
0	X	X	0	Off, error storage "OFF"		

Note!



Jumper J7 only exists from version 1.4.2 of the control board. Error storage "ON" means that the error "phase failure" is shown via LED until you confirm. Error storage "OFF" how-ever means that the error "phase failure" is shown via LED only as long as the failure really exists.

Stop!



Pull off the jumper J3 is only allowed by interrupting the pulses of the frequency inverter or of the power feed/feedback unit in the case of switching off the mains by series interrupting devices like contactors, main switches or any others. This is necessary to stop the power feed/feedback to prevent a dangerous voltage rise on devices in the sector where the power is switched-off. The Jumper J7 should only be removed in the case of Jumper J3 is removed. Otherwise when the phase-failure-supervision is active a "phase failure" will only be shown as long as the failure does exist (no error storage).

f) Overvoltage supervision

Since the control board version 1.4.3 the device has an overvoltage supervision for the mains which switches off the device in the case of a voltage level of approximately 1,15 x U_N and above. As an error message the error code 3 will be shown (see chapter 7.1). For the differentiation of the error messages phase failure and overvoltage you have the possibility to deactivate the phase-failure-supervision by removing the jumper J3 on the control board. If after that a switch-off with the indication via the red and yellow LED (error code 3) happens, an overvoltage will be the reason of the switch-off then.

J3	J5	J6	J7	J8	LED Message			Evaluation (overvoltage)
—	X	X	—	—	Green	1.red	yellow	Overvoltage a/o phase failure/ commutation error
—	X	X	0	—	green	—	yellow	Overvoltage
0	X	X	—	—	green	1.red	yellow	Overvoltage a/o phase failure/ commutation error
0	X	X	0	—	green	—	yellow	Overvoltage
0	X	X	0	—	green	1.red	yellow	Constant phase failure

Remark:

- 0 Jumper open
- Jumper closed
- X Jumper random

Standard adjustment of the device

Autostart and no switching off in case of phase failure

Troubleshooting and fault elimination

9 Troubleshooting and fault elimination

The five LED's in the cover of the power feed/feedback unit display the operating condition. For easier visibility during service and first powering up similar LEDs are placed on the control board.

Stop!

If the power feed/feedback unit trips during retardation, it must not be reset until the end of the retardation and until the DC-bus voltage has fallen to normal values.



To avoid any kind of problems you can block the impulse-release of the inverter by connecting the collective-error-relay-contact of the power-feed/feedback-unit with the corresponding connection of the frequency inverter.

U_{CE}-tripping:

The power feed/feedback unit trips by the U_{CE}-protective-circuitry, if the specific maximum current of the device is exceeded. The principle of this protective-circuitry implies that for a short time (less than one millisecond) the IGBT is stressed over its specification for normal operation. For an single case this means no problem for the power feed/feedback unit. However, if the over current cut off arises often or even periodically, the high power semiconductors will age very rapidly and fail premature.

The cause of periodical U_{CE} cut offs may be over load, under voltage in the network, a defective or oscillating controller, an oscillating reference input or a wrong design of the plant.

Troubleshooting and fault elimination

9.1 LED-messages

LED-display: Error code:	LED – display				
	Operation	Phase failure	U _{CE}	Overtemperature	Disturbance
	Green	Red	Red	Orange	Yellow
1	X				
2	X				
3	X*			X*	X
4	X				X
5	X				X
6	X				X
7	X	X			X
8	X		X		X
9	X	X	X		X
10	X*	X	X	X*	X
11					
12	X				X
13	X	X			

Table 9.1.1

Troubleshooting and fault elimination

LED-display Error code:	Status report		Relay status
	At commissioning	During operation	
1	Ready to operate (after approx. 1s)	System in operation	Relay in resting position
2	Ready for operation, but no power feedback ⇒ Check the DC-fuses.		Relay in resting position
3		Overtemperature of the heat sink ⇒ Error-message is not resettable as long as the temperature is too high.	Relay dropout
4		Error code 3 ⇒ Heat sink temperature declined to normal and the error is rese- table.	Relay dropout
5	System has been switched off, (external OFF) ⇒ Reset necessary	System has been switched off, (external OFF) ⇒ Reset necessary	Relay dropout
6	Overvoltage has been detected (J8 closed) ⇒ After grid volt- age has declined to its nominal value, reset necessary		Relay dropout
7	Rotary field orientation incorrect or one phase is missing	Phase failure has been detected ⇒ Reset necessary	Relay dropout
8		Overcurrent has been detected ⇒ Reset necessary	Relay dropout
9	Error code 7 and 8	Overcurrent and phase failure have been detected simultaneously.	Relay dropout
10	Several errors have been detected simultaneously	Several errors have been detected simultaneously	Relay dropout
11	System off, at least two phases lost	System off, at least two phases lost.	Relay dropout
12		With option IFP: I ² t-tripping ⇒ Reset necessary	Relay dropout
13		Voltage breakdown during com- mutation but without tripping as jumper 3 and 7 are open (chapter 6e) ⇒ Operation possible, mains sup- ply improvement recommended	Relay dropout

Table 9.1.2

10 Service

The power feed/feedback unit is maintenance-free, if the provided application conditions are observed (refer to chapter 3.2).

If the cooling air is polluted, the cooling air input may be blocked. Therefore check the power feed/feedback unit periodically (depending on the degree of pollution approx. every 4 weeks).

Stop!

Don't use sharp or tapering objects like knife or screw driver to clean the cooling air input.

Clean the cooling air input with a vacuum cleaner.



Appendix

11 Appendix

11.1 Options

1. Fuse holder with fuses for mains supply

In accordance with table 3.3.3.1.1-5 for the power feed/feedback unit the following fuses are available:

REVCON® - type	Order designation	Case type
RFE 30 to RFE 60	SH RFE ZZZ-XXX	A
RFE 80 to RFE 125	SH RFE ZZZ-XXX	B
RFE 150 to RFE 285	SH RFE ZZZ-XXX	C

ZZZ \cong rated power of the power feed/feedback unit

XXX \cong rated voltage of the power feed/feedback unit

2. Option IL (Isolating lacquer)

To protect the electronic components of the power feed/feedback unit from pollution of the cooling air, all printed circuit boards may be coated with an isolating lacquer. This option improves the service reliability, but it doesn't release the user from the duty to observe the in chapter 3.2 specified application conditions.

3. Overvoltage-suppressor

If the power feed/feedback unit (as well as a controller) is connected to ungrounded mains supply, it only may be run, either if it is connected via an isolating transformer or if the plant is protected by overvoltage suppressors. But also with grounded mains supply it may be useful to install overvoltage suppressors, if it is possible, that voltage peaks occur. For choosing the best overvoltage suppressor for your specific application, please get in contact with one of our technicians.

4. External operating an signalling panel

When mounting the device inside a cabinet it is possible to mount a operator panel in the door of the cabinet by using the external operating and signalling panel. The external operating and signalling panel contains the complete display (LED's) of all running and failure messages of the power feed/feedback unit and also the ON / RESET push button switch. The connection to the power feed/feedback unit has to be done with a (shielded) flat cable to the socket X4 of the control board (refer to figure 4.4.4.1).

Note!



The connection of the external operating and signalling panel to the power feed/feedback unit has no influence on the operating and error messages of the LED's placed on the control board. In this case both displays are active on the same time. In case of simultaneous usage of the external operating and signalling panel and the ON/OFF function via the control terminal X2 the switch off signal always has priority, independent of the ON-RESTE push button switch.



Stop!

Don't put an external voltage to the socket X4 of the control board or to the external operating and signalling panel. This may damage the device.

5. Option RHF-module

Like a standard controller the power feed/feedback unit takes the power from the mains via an uncontrolled diode bridge. In comparison with a direct supplied motor one advantage is the constant displacement power factor of nearly 1. The disadvantage is that the mains current has got a significant harmonic component. With the option SKS-module for the power feed/feedback unit sine wave mains currents (THD I =5-16% depending on controller and load) are generated. This option cannot retrofit, it must be ordered together with the power feed/feedback unit! For detailed information please get in contact with our technical department.

6. Option PPB

The option PPB is required if a RHF-R is used to prevent a device defect at phase interchanging.

Appendix

7. Option additional supply module REVCON EDC

If there is for a certain application indeed enough feedback power but not enough supply power of the power feed- and feedback unit, it is possible by means of an individual to dimensioning additional supply module to reach the necessary complete supply power. This option is not retrofit able, it must be requested at the order of the power feed- and feedback unit! For more detailed Information about this option please get in contact with one of our Technicians of our company.

8. Option POF REVCON RFE B3/D3

Option POF (Pulse lock without error message): To switch-off the feedback operation at standby operation at maintenance of the supply operation the option POF can be chosen. This function enables a lowering of the power loss at standby operation of 120W to <30W.

At devices with the option POF the internal wiring is already applied.

This option requires 24V at the additional terminals A1 and A2 which can be triggered at absolute supply operation.

At 0V is the pulse lock activated, at 24 V is the pulse enable activated.

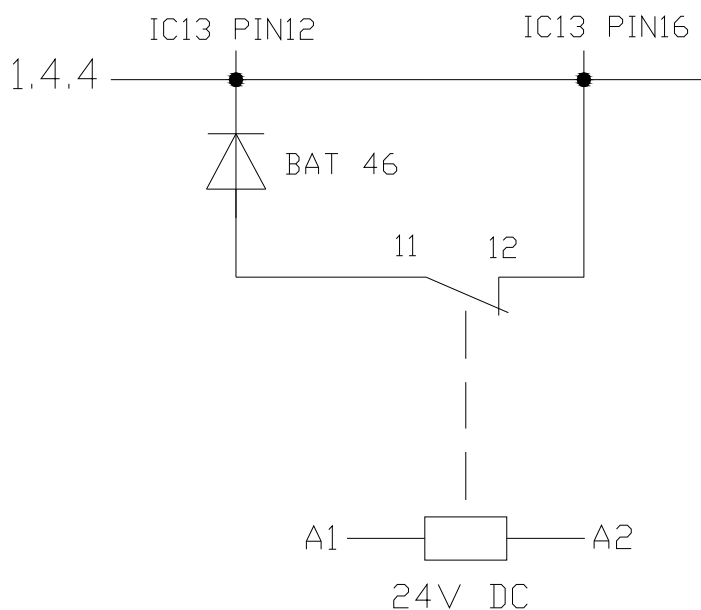

Figure 10.1.1: Connection diagram of the option POF

12 REVCON[®] Product overview

1. REVCON[®] RLD

Power feedback units for short time operation
(Crane systems, discontinuous centrifugal, etc.)

2. REVCON[®] RHD

Power feedback units for continuous operation
(Engine test beds, escalators, wind energy plants, elevators etc.)

3. REVCON[®] HSTV

Boost-converter for the generation of an increased direct current link voltage for the torque increasing in over- synchronous range of speeds

4. REVCON[®] HST

Step- up converter for the generation of a current controlled, high output voltage from a lower input DC voltage.

5. REVCON[®] TST

Step- down converter for the generation of a decreased output voltage from a higher DC voltage (AC output is also possible).

- Voltage controlled: A free selectable output voltage in wide limits

The required output voltage can be adjusted by set-point (0 ... 10V)

- Current controlled: A lower output voltage that adjusts free in dependence of the load

The required output current can be adjusted by set-point (0 ... 10V)

6. REVCON[®] EDC

Power supply module for multiple motor applications (supply of multiple drive controller) without generator- operation

7. REVCON[®] RHF

Filter module for the generation of sinusoidal line currents (THD I 5-16% according to the frequency converter and the load). Filter module of the newest generation with smaller dimensions and reduced weight and better performance

All products are available for 400V line voltage, the most also for 230V, 400V, 460V, 500V, 600V and 690V! According to the product power from 4 to 440kW can be transmitted, whereby the most products are appropriate for parallel connection, so that power ratings until the megawatt range can be achieved!

Appendix

13 Contact

Eltroplan-REVCON Elektrotechnische Anlagen GmbH

Edisonstraße 3

D-59199 Bönen

Phone +49 (0)2383 920 22 22

Fax +49 (0)2383 920 22 66

E-Mail info@REVCON.de

Web www.REVCON.de

< SUBJECT TO CHANGE WITHOUT NOTICE >

13/05

The in these operating instructions contained details and technical data must be checked by the customer before acquisition and application. The customer can raise no claims from these documents, compared to Eltroplan- REVCON® or Eltroplan- REVCON®-staff, unless that these have acted intentional or grossly negligent. Eltroplan- REVCON® reserves the right to perform, without previous announcements within the appropriate and reasonable changes at their products - also at already commissioned. All rights reserved.
