



OM-211 958L

2009-04

Processes



MIG (GMAW) Welding

Description



Feeder Gun

Spoolmatic[®] 30A w/Special Length Cables

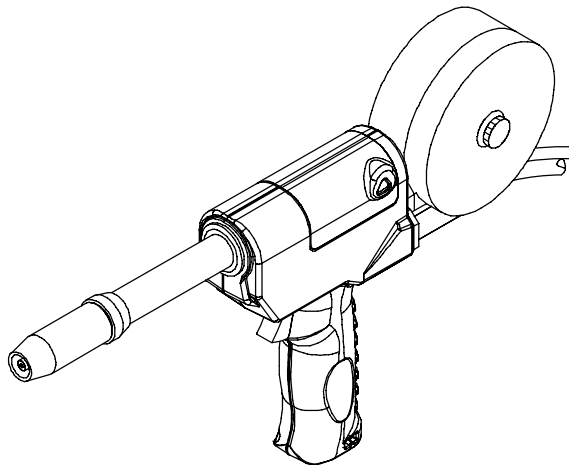

Visit our website at
www.MillerWelds.com

OWNER'S MANUAL

File: MIG (GMAW)



From Miller to You

Thank you and congratulations on choosing Miller. Now you can get the job done and get it done right. We know you don't have time to do it any other way.

That's why when Niels Miller first started building arc welders in 1929, he made sure his products offered long-lasting value and superior quality. Like you, his customers couldn't afford anything less. Miller products had to be more than the best they could be. They had to be the best you could buy.

Today, the people that build and sell Miller products continue the tradition. They're just as committed to providing equipment and service that meets the high standards of quality and value established in 1929.

This Owner's Manual is designed to help you get the most out of your Miller products. Please take time to read the Safety precautions. They will help you protect yourself against potential hazards on the worksite.

We've made installation and operation quick and easy. With Miller you can count on years of reliable service with proper maintenance. And if for some reason the unit needs repair, there's a Troubleshooting section that will help you figure out what the problem is. The parts list will then help you to decide the exact part you may need to fix the problem. Warranty and service information for your particular model are also provided.



Miller is the first welding equipment manufacturer in the U.S.A. to be registered to the ISO 9001:2000 Quality System Standard.

Miller Electric manufactures a full line of welders and welding related equipment. For information on other quality Miller products, contact your local Miller distributor to receive the latest full line catalog or individual specification sheets. **To locate your nearest distributor or service agency call 1-800-4-A-Miller, or visit us at www.MillerWelds.com on the web.**



Working as hard as you do – every power source from Miller is backed by the most hassle-free warranty in the business.



TABLE OF CONTENTS

SECTION 1 – SAFETY PRECAUTIONS - READ BEFORE USING	1
1-1. Symbol Usage	1
1-2. Arc Welding Hazards	1
1-3. Additional Symbols For Installation, Operation, And Maintenance	3
1-4. California Proposition 65 Warnings	4
1-5. Principal Safety Standards	4
1-6. EMF Information	4
SECTION 2 – CONSIGNES DE SÉCURITÉ – LIRE AVANT UTILISATION	5
2-1. Symboles utilisés	5
2-2. Dangers relatifs au soudage à l'arc	5
2-3. Dangers supplémentaires en relation avec l'installation, le fonctionnement et la maintenance	7
2-4. Proposition californienne 65 Avertissements	8
2-5. Principales normes de sécurité	9
2-6. Information EMF	9
SECTION 3 – DEFINITIONS	11
3-1. WEEE Label (For Products Sold Within The EU)	11
3-2. Symbols And Definitions	11
SECTION 4 – INSTALLATION	12
4-1. Specifications	12
4-2. Removing Top Cover	12
4-3. Installing Wire Spool And Threading Welding Wire	13
4-4. Rotating Canister	13
4-5. Connecting To 24 Volt Weld Control	14
4-6. Connecting To 115 Volt Weld Control	14
4-7. Installing Gas Supply	15
4-8. Adjusting Drive Roll And Spool Brake Pressure	16
SECTION 5 – OPERATION	17
5-1. Controls	17
5-2. Shielding Gas	17
SECTION 6 – MAINTENANCE & TROUBLESHOOTING	18
6-1. Routine Maintenance	18
6-2. Changing Gun Contact Tip	18
6-3. Replacing Head Tube Liner	19
6-4. Gun Drive Assembly Maintenance	20
6-5. Replacing Canister Inlet Guide	21
6-6. Replacing Spool Canister	21
6-7. Replacing Diffuser	22
6-8. Troubleshooting	22
SECTION 7 – ELECTRICAL DIAGRAM	23
SECTION 8 – PARTS LIST	24
SECTION 9 – PARTS LIST INCLUDING CONSUMABLES	27
OPTIONS AND ACCESSORIES	
WARRANTY	

SECTION 1 – SAFETY PRECAUTIONS - READ BEFORE USING

som_2007-04

 Protect yourself and others from injury — read and follow these precautions.

1-1. Symbol Usage



DANGER! – Indicates a hazardous situation which, if not avoided, will result in death or serious injury. The possible hazards are shown in the adjoining symbols or explained in the text.



Indicates a hazardous situation which, if not avoided, could result in death or serious injury. The possible hazards are shown in the adjoining symbols or explained in the text.

NOTICE – Indicates statements not related to personal injury.

 Indicates special instructions.



This group of symbols means Warning! Watch Out! ELECTRIC SHOCK, MOVING PARTS, and HOT PARTS hazards. Consult symbols and related instructions below for necessary actions to avoid the hazards.

1-2. Arc Welding Hazards



The symbols shown below are used throughout this manual to call attention to and identify possible hazards. When you see the symbol, watch out, and follow the related instructions to avoid the hazard. The safety information given below is only a summary of the more complete safety information found in the Safety Standards listed in Section 1-5. Read and follow all Safety Standards.



Only qualified persons should install, operate, maintain, and repair this unit.



During operation, keep everybody, especially children, away.



ELECTRIC SHOCK can kill.

Touching live electrical parts can cause fatal shocks or severe burns. The electrode and work circuit is electrically live whenever the output is on. The input power circuit and machine internal circuits are also live when power is on. In semiautomatic or automatic wire welding, the wire, wire reel, drive roll housing, and all metal parts touching the welding wire are electrically live. Incorrectly installed or improperly grounded equipment is a hazard.

- Do not touch live electrical parts.
- Wear dry, hole-free insulating gloves and body protection.
- Insulate yourself from work and ground using dry insulating mats or covers big enough to prevent any physical contact with the work or ground.
- Do not use AC output in damp areas, if movement is confined, or if there is a danger of falling.
- Use AC output ONLY if required for the welding process.
- If AC output is required, use remote output control if present on unit.
- Additional safety precautions are required when any of the following electrically hazardous conditions are present: in damp locations or while wearing wet clothing; on metal structures such as floors, gratings, or scaffolds; when in cramped positions such as sitting, kneeling, or lying; or when there is a high risk of unavoidable or accidental contact with the workpiece or ground. For these conditions, use the following equipment in order presented: 1) a semiautomatic DC constant voltage (wire) welder, 2) a DC manual (stick) welder, or 3) an AC welder with reduced open-circuit voltage. In most situations, use of a DC, constant voltage wire welder is recommended. And, do not work alone!
- Disconnect input power or stop engine before installing or servicing this equipment. Lockout/tagout input power according to OSHA 29 CFR 1910.147 (see Safety Standards).
- Properly install and ground this equipment according to its Owner's Manual and national, state, and local codes.

- Always verify the supply ground – check and be sure that input power cord ground wire is properly connected to ground terminal in disconnect box or that cord plug is connected to a properly grounded receptacle outlet.
- When making input connections, attach proper grounding conductor first – double-check connections.
- Keep cords dry, free of oil and grease, and protected from hot metal and sparks.
- Frequently inspect input power cord for damage or bare wiring – replace cord immediately if damaged – bare wiring can kill.
- Turn off all equipment when not in use.
- Do not use worn, damaged, undersized, or poorly spliced cables.
- Do not drape cables over your body.
- If earth grounding of the workpiece is required, ground it directly with a separate cable.
- Do not touch electrode if you are in contact with the work, ground, or another electrode from a different machine.
- Do not touch electrode holders connected to two welding machines at the same time since double open-circuit voltage will be present.
- Use only well-maintained equipment. Repair or replace damaged parts at once. Maintain unit according to manual.
- Wear a safety harness if working above floor level.
- Keep all panels and covers securely in place.
- Clamp work cable with good metal-to-metal contact to workpiece or worktable as near the weld as practical.
- Insulate work clamp when not connected to workpiece to prevent contact with any metal object.
- Do not connect more than one electrode or work cable to any single weld output terminal.

SIGNIFICANT DC VOLTAGE exists in inverter-type welding power sources after removal of input power.

- Turn Off inverter, disconnect input power, and discharge input capacitors according to instructions in Maintenance Section before touching any parts.



HOT PARTS can cause severe burns.

- Do not touch hot parts bare handed.
- Allow cooling period before working on gun or torch.
- To handle hot parts, use proper tools and/or wear heavy, insulated welding gloves and clothing to prevent burns.



FUMES AND GASES can be hazardous.

Welding produces fumes and gases. Breathing these fumes and gases can be hazardous to your health.

- Keep your head out of the fumes. Do not breathe the fumes.
- If inside, ventilate the area and/or use local forced ventilation at the arc to remove welding fumes and gases.
- If ventilation is poor, wear an approved air-supplied respirator.
- Read and understand the Material Safety Data Sheets (MSDSs) and the manufacturer's instructions for metals, consumables, coatings, cleaners, and degreasers.
- Work in a confined space only if it is well ventilated, or while wearing an air-supplied respirator. Always have a trained watchperson nearby. Welding fumes and gases can displace air and lower the oxygen level causing injury or death. Be sure the breathing air is safe.
- Do not weld in locations near degreasing, cleaning, or spraying operations. The heat and rays of the arc can react with vapors to form highly toxic and irritating gases.
- Do not weld on coated metals, such as galvanized, lead, or cadmium plated steel, unless the coating is removed from the weld area, the area is well ventilated, and while wearing an air-supplied respirator. The coatings and any metals containing these elements can give off toxic fumes if welded.



ARC RAYS can burn eyes and skin.

Arc rays from the welding process produce intense visible and invisible (ultraviolet and infrared) rays that can burn eyes and skin. Sparks fly off from the weld.

- Wear an approved welding helmet fitted with a proper shade of filter lenses to protect your face and eyes when welding or watching (see ANSI Z49.1 and Z87.1 listed in Safety Standards).
- Wear approved safety glasses with side shields under your helmet.
- Use protective screens or barriers to protect others from flash, glare and sparks; warn others not to watch the arc.
- Wear protective clothing made from durable, flame-resistant material (leather, heavy cotton, or wool) and foot protection.



WELDING can cause fire or explosion.

Welding on closed containers, such as tanks, drums, or pipes, can cause them to blow up. Sparks can fly off from the welding arc. The flying sparks, hot workpiece, and hot equipment can cause fires and burns. Accidental contact of electrode to metal objects can cause sparks, explosion, overheating, or fire. Check and be sure the area is safe before doing any welding.

- Remove all flammables within 35 ft (10.7 m) of the welding arc. If this is not possible, tightly cover them with approved covers.
- Do not weld where flying sparks can strike flammable material.
- Protect yourself and others from flying sparks and hot metal.
- Be alert that welding sparks and hot materials from welding can easily go through small cracks and openings to adjacent areas.
- Watch for fire, and keep a fire extinguisher nearby.
- Be aware that welding on a ceiling, floor, bulkhead, or partition can cause fire on the hidden side.
- Do not weld on closed containers such as tanks, drums, or pipes, unless they are properly prepared according to AWS F4.1 (see Safety Standards).
- Do not weld where the atmosphere may contain flammable dust, gas, or liquid vapors (such as gasoline).
- Connect work cable to the work as close to the welding area as practical to prevent welding current from traveling long, possibly unknown paths and causing electric shock, sparks, and fire hazards.

- Do not use welder to thaw frozen pipes.
- Remove stick electrode from holder or cut off welding wire at contact tip when not in use.
- Wear oil-free protective garments such as leather gloves, heavy shirt, cuffless trousers, high shoes, and a cap.
- Remove any combustibles, such as a butane lighter or matches, from your person before doing any welding.
- After completion of work, inspect area to ensure it is free of sparks, glowing embers, and flames.
- Use only correct fuses or circuit breakers. Do not oversize or bypass them.
- Follow requirements in OSHA 1910.252 (a) (2) (iv) and NFPA 51B for hot work and have a fire watcher and extinguisher nearby.



FLYING METAL or DIRT can injure eyes.

- Welding, chipping, wire brushing, and grinding cause sparks and flying metal. As welds cool, they can throw off slag.
- Wear approved safety glasses with side shields even under your welding helmet.



BUILDUP OF GAS can injure or kill.

- Shut off shielding gas supply when not in use.
- Always ventilate confined spaces or use approved air-supplied respirator.

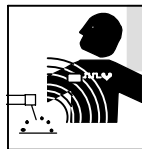

MAGNETIC FIELDS can affect Implanted Medical Devices.

- Wearers of Pacemakers and other Implanted Medical Devices should keep away.
- Implanted Medical Device wearers should consult their doctor and the device manufacturer before going near arc welding, spot welding, gouging, plasma arc cutting, or induction heating operations.



NOISE can damage hearing.

Noise from some processes or equipment can damage hearing.

- Wear approved ear protection if noise level is high.



CYLINDERS can explode if damaged.

Shielding gas cylinders contain gas under high pressure. If damaged, a cylinder can explode. Since gas cylinders are normally part of the welding process, be sure to treat them carefully.

- Protect compressed gas cylinders from excessive heat, mechanical shocks, physical damage, slag, open flames, sparks, and arcs.
- Install cylinders in an upright position by securing to a stationary support or cylinder rack to prevent falling or tipping.
- Keep cylinders away from any welding or other electrical circuits.
- Never drape a welding torch over a gas cylinder.
- Never allow a welding electrode to touch any cylinder.
- Never weld on a pressurized cylinder – explosion will result.
- Use only correct shielding gas cylinders, regulators, hoses, and fittings designed for the specific application; maintain them and associated parts in good condition.
- Turn face away from valve outlet when opening cylinder valve.
- Keep protective cap in place over valve except when cylinder is in use or connected for use.
- Use the right equipment, correct procedures, and sufficient number of persons to lift and move cylinders.
- Read and follow instructions on compressed gas cylinders, associated equipment, and Compressed Gas Association (CGA) publication P-1 listed in Safety Standards.

1-3. Additional Symbols For Installation, Operation, And Maintenance



FIRE OR EXPLOSION hazard.

- Do not install or place unit on, over, or near combustible surfaces.
- Do not install unit near flammables.
- Do not overload building wiring – be sure power supply system is properly sized, rated, and protected to handle this unit.



FALLING UNIT can cause injury.

- Use lifting eye to lift unit only, NOT running gear, gas cylinders, or any other accessories.
- Use equipment of adequate capacity to lift and support unit.
- If using lift forks to move unit, be sure forks are long enough to extend beyond opposite side of unit.



OVERUSE can cause OVERHEATING

- Allow cooling period; follow rated duty cycle.
- Reduce current or reduce duty cycle before starting to weld again.
- Do not block or filter airflow to unit.

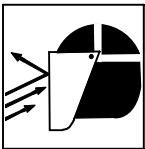

FLYING SPARKS can cause injury.

- Wear a face shield to protect eyes and face.
- Shape tungsten electrode only on grinder with proper guards in a safe location wearing proper face, hand, and body protection.
- Sparks can cause fires — keep flammables away.



STATIC (ESD) can damage PC boards.

- Put on grounded wrist strap BEFORE handling boards or parts.
- Use proper static-proof bags and boxes to store, move, or ship PC boards.



MOVING PARTS can cause injury.

- Keep away from moving parts.
- Keep away from pinch points such as drive rolls.



WELDING WIRE can cause injury.

- Do not press gun trigger until instructed to do so.
- Do not point gun toward any part of the body, other people, or any metal when threading welding wire.



MOVING PARTS can cause injury.

- Keep away from moving parts such as fans.
- Keep all doors, panels, covers, and guards closed and securely in place.
- Have only qualified persons remove doors, panels, covers, or guards for maintenance as necessary.
- Reinstall doors, panels, covers, or guards when maintenance is finished and before reconnecting input power.

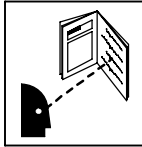

READ INSTRUCTIONS.

- Read Owner's Manual before using or servicing unit.
- Use only genuine replacement parts from the manufacturer.

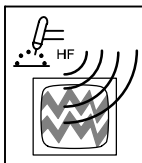

H.F. RADIATION can cause interference.

- High-frequency (H.F.) can interfere with radio navigation, safety services, computers, and communications equipment.
- Have only qualified persons familiar with electronic equipment perform this installation.
- The user is responsible for having a qualified electrician promptly correct any interference problem resulting from the installation.
- If notified by the FCC about interference, stop using the equipment at once.
- Have the installation regularly checked and maintained.
- Keep high-frequency source doors and panels tightly shut, keep spark gaps at correct setting, and use grounding and shielding to minimize the possibility of interference.



ARC WELDING can cause interference.

- Electromagnetic energy can interfere with sensitive electronic equipment such as computers and computer-driven equipment such as robots.
- Be sure all equipment in the welding area is electromagnetically compatible.
- To reduce possible interference, keep weld cables as short as possible, close together, and down low, such as on the floor.
- Locate welding operation 100 meters from any sensitive electronic equipment.
- Be sure this welding machine is installed and grounded according to this manual.
- If interference still occurs, the user must take extra measures such as moving the welding machine, using shielded cables, using line filters, or shielding the work area.

1-4. California Proposition 65 Warnings

 Welding or cutting equipment produces fumes or gases which contain chemicals known to the State of California to cause birth defects and, in some cases, cancer. (California Health & Safety Code Section 25249.5 et seq.)

 Battery posts, terminals and related accessories contain lead and lead compounds, chemicals known to the State of California to cause cancer and birth defects or other reproductive harm. Wash hands after handling.

For Gasoline Engines:

 Engine exhaust contains chemicals known to the State of California to cause cancer, birth defects, or other reproductive harm.

For Diesel Engines:

 Diesel engine exhaust and some of its constituents are known to the State of California to cause cancer, birth defects, and other reproductive harm.

1-5. Principal Safety Standards

Safety in Welding, Cutting, and Allied Processes, ANSI Standard Z49.1, from Global Engineering Documents (phone: 1-877-413-5184, website: www.global.ihs.com).

Recommended Safe Practices for the Preparation for Welding and Cutting of Containers and Piping, American Welding Society Standard AWS F4.1, from Global Engineering Documents (phone: 1-877-413-5184, website: www.global.ihs.com).

National Electrical Code, NFPA Standard 70, from National Fire Protection Association, P.O. Box 9101, Quincy, MA 02269-9101 (phone: 617-770-3000, website: www.nfpa.org and www.sparky.org).

Safe Handling of Compressed Gases in Cylinders, CGA Pamphlet P-1, from Compressed Gas Association, 4221 Walney Road, 5th Floor, Chantilly, VA 20151 (phone: 703-788-2700, website: www.cganet.com).

Code for Safety in Welding and Cutting, CSA Standard W117.2, from Canadian Standards Association, Standards Sales, 5060 Mississauga,

Ontario, Canada L4W 5NS (phone: 800-463-6727 or in Toronto 416-747-4044, website: www.csa-international.org).

Safe Practice For Occupational And Educational Eye And Face Protection, ANSI Standard Z87.1, from American National Standards Institute, 25 West 43rd Street, New York, NY 10036-8002 (phone: 212-642-4900, website: www.ansi.org).

Standard for Fire Prevention During Welding, Cutting, and Other Hot Work, NFPA Standard 51B, from National Fire Protection Association, P.O. Box 9101, Quincy, MA 02269-9101 (phone: 617-770-3000, website: www.nfpa.org).

OSHA, Occupational Safety and Health Standards for General Industry, Title 29, Code of Federal Regulations (CFR), Part 1910, Subpart Q, and Part 1926, Subpart J, from U.S. Government Printing Office, Superintendent of Documents, P.O. Box 371954, Pittsburgh, PA 15250-7954 (phone: 1-866-512-1800) (there are 10 Regional Offices—phone for Region 5, Chicago, is 312-353-2220, website: www.osha.gov).

1-6. EMF Information

Considerations About Welding And The Effects Of Low Frequency Electric And Magnetic Fields

Welding current, as it flows through welding cables, will cause electromagnetic fields. There has been and still is some concern about such fields. However, after examining more than 500 studies spanning 17 years of research, a special blue ribbon committee of the National Research Council concluded that: "The body of evidence, in the committee's judgment, has not demonstrated that exposure to power-frequency electric and magnetic fields is a human-health hazard." However, studies are still going forth and evidence continues to be examined. Until the final conclusions of the research are reached, you may wish to minimize your exposure to electromagnetic fields when welding or cutting.

To reduce magnetic fields in the workplace, use the following procedures:

1. Keep cables close together by twisting or taping them, or using a cable cover.
2. Arrange cables to one side and away from the operator.
3. Do not coil or drape cables around your body.
4. Keep welding power source and cables as far away from operator as practical.
5. Connect work clamp to workpiece as close to the weld as possible.

About Implanted Medical Devices:

Implanted Medical Device wearers should consult their doctor and the device manufacturer before performing or going near arc welding, spot welding, gouging, plasma arc cutting, or induction heating operations. If cleared by your doctor, then following the above procedures is recommended.

SECTION 2 – CONSIGNES DE SÉCURITÉ – LIRE AVANT UTILISATION

fre_som_2007-04

! Se protéger et protéger les autres contre le risque de blessure — lire et respecter ces consignes.

2-1. Symboles utilisés



DANGER! – Indique une situation dangereuse qui si on l'évite pas peut donner la mort ou des blessures graves. Les dangers possibles sont montrés par les symboles joints ou sont expliqués dans le texte.



Indique une situation dangereuse qui si on l'évite pas peut donner la mort ou des blessures graves. Les dangers possibles sont montrés par les symboles joints ou sont expliqués dans le texte.

NOTE – Indique des déclarations pas en relation avec des blessures personnelles.

 Indique des instructions spécifiques.



Ce groupe de symboles veut dire Avertissement! Attention! DANGER DE CHOC ELECTRIQUE, PIECES EN MOUVEMENT, et PIECES CHAUDES. Consulter les symboles et les instructions ci-dessous y afférant pour les actions nécessaires afin d'éviter le danger.

2-2. Dangers relatifs au soudage à l'arc



Les symboles représentés ci-dessous sont utilisés dans ce manuel pour attirer l'attention et identifier les dangers possibles. En présence de l'un de ces symboles, prendre garde et suivre les instructions afférentes pour éviter tout risque. Les instructions en matière de sécurité indiquées ci-dessous ne constituent qu'un sommaire des instructions de sécurité plus complètes fournies dans les normes de sécurité énumérées dans la Section 2-5. Lire et observer toutes les normes de sécurité.



Seul un personnel qualifié est autorisé à installer, faire fonctionner, entretenir et réparer cet appareil.



Pendant le fonctionnement, maintenir à distance toutes les personnes, notamment les enfants de l'appareil.



UNE DÉCHARGE ÉLECTRIQUE peut entraîner la mort.

Le contact d'organes électriques sous tension peut provoquer des accidents mortels ou des brûlures graves. Le circuit de l'électrode et de la pièce est sous tension lorsque le courant est délivré à la sortie. Le circuit d'alimentation et les circuits internes de la machine sont également sous tension lorsque l'alimentation est sur Marche. Dans le mode de soudage avec du fil, le fil, le dérouleur, le bloc de commande du rouleau et toutes les parties métalliques en contact avec le fil sont sous tension électrique. Un équipement installé ou mis à la terre de manière incorrecte ou impropre constitue un danger.

- Ne pas toucher aux pièces électriques sous tension.
- Porter des gants isolants et des vêtements de protection secs et sans trous.
- S'isoler de la pièce à couper et du sol en utilisant des housses ou des tapis assez grands afin d'éviter tout contact physique avec la pièce à couper ou le sol.
- Ne pas se servir de source électrique à courant électrique dans les zones humides, dans les endroits confinés ou là où on risque de tomber.
- Se servir d'une source électrique à courant électrique UNIQUEMENT si le procédé de soudage le demande.
- Si l'utilisation d'une source électrique à courant électrique s'avère nécessaire, se servir de la fonction de télécommande si l'appareil en est équipé.
- D'autres consignes de sécurité sont nécessaires dans les conditions suivantes : risques électriques dans un environnement humide ou si l'on porte des vêtements mouillés ; sur des structures métalliques telles que sols, grilles ou échafaudages ; en position coincée comme assise, à genoux ou couchée ; ou s'il y a un risque élevé de contact inévitable ou accidentel avec la pièce à souder ou le sol. Dans ces conditions, utiliser les équipements suivants, dans l'ordre indiqué : 1) un poste à souder DC à tension constante (à fil), 2) un poste à souder DC manuel (électrode) ou 3) un poste à souder AC à tension à vide réduite. Dans la plupart des situations, l'utilisation d'un poste à souder DC à fil à tension constante est recommandée. En outre, ne pas travailler seul !
- Couper l'alimentation ou arrêter le moteur avant de procéder à l'installation, à la réparation ou à l'entretien de l'appareil. Déverrouiller l'alimentation selon la norme OSHA 29 CFR 1910.147 (voir normes de sécurité).
- Installer le poste correctement et le mettre à la terre convenablement selon les consignes du manuel de l'opérateur et les normes nationales, provinciales et locales.
- Toujours vérifier la terre du cordon d'alimentation. Vérifier et s'assurer que le fil de terre du cordon d'alimentation est bien raccordé à la borne de terre du sectionneur ou que la fiche du cordon est raccordée à une prise correctement mise à la terre.
- En effectuant les raccordements d'entrée, fixer d'abord le conducteur de mise à la terre approprié et contre-vérifier les connexions.
- Les câbles doivent être exempts d'humidité, d'huile et de graisse; protégez-les contre les étincelles et les pièces métalliques chaudes.
- Vérifier fréquemment le cordon d'alimentation afin de s'assurer qu'il n'est pas altéré ou à nu, le remplacer immédiatement s'il l'est. Un fil à nu peut entraîner la mort.
- L'équipement doit être hors tension lorsqu'il n'est pas utilisé.
- Ne pas utiliser des câbles usés, endommagés, de grosseur insuffisante ou mal épissés.
- Ne pas enrouler les câbles autour du corps.
- Si la pièce soudée doit être mise à la terre, le faire directement avec un câble distinct.
- Ne pas toucher l'électrode quand on est en contact avec la pièce, la terre ou une électrode provenant d'une autre machine.
- Ne pas toucher des porte électrodes connectés à deux machines en même temps à cause de la présence d'une tension à vide doublée.
- N'utiliser qu'un matériel en bon état. Réparer ou remplacer sur-le-champ les pièces endommagées. Entretenir l'appareil conformément à ce manuel.
- Porter un harnais de sécurité si l'on doit travailler au-dessus du sol.
- S'assurer que tous les panneaux et couvercles sont correctement en place.
- Fixer le câble de retour de façon à obtenir un bon contact métal-métal avec la pièce à souder ou la table de travail, le plus près possible de la soudure.
- Isoler la pince de masse quand pas mis à la pièce pour éviter le contact avec tout objet métallique.
- Ne pas raccorder plus d'une électrode ou plus d'un câble de masse à une même borne de sortie de soudage.

Il reste une TENSION DC NON NÉGLIGEABLE dans les sources de soudage onduleur quand on a coupé l'alimentation.

- Arrêter les convertisseurs, débrancher le courant électrique et décharger les condensateurs d'alimentation selon les instructions indiquées dans la partie Entretien avant de toucher les pièces.



DES PIÈCES CHAUDES peuvent provoquer des brûlures graves.

- Ne pas toucher à mains nues les parties chaudes.
- Prévoir une période de refroidissement avant de travailler à l'équipement.
- Ne pas toucher aux pièces chaudes, utiliser les outils recommandés et porter des gants de soudage et des vêtements épais pour éviter les brûlures.



LES FUMÉES ET LES GAZ peuvent être dangereux.

Le soudage génère des fumées et des gaz. Leur inhalation peut être dangereux pour votre santé.

- Eloigner votre tête des fumées. Ne pas respirer les fumées.
- À l'intérieur, ventiler la zone et/ou utiliser une ventilation forcée au niveau de l'arc pour l'évacuation des fumées et des gaz de soudage.
- Si la ventilation est médiocre, porter un respirateur anti-vapeurs approuvé.
- Lire et comprendre les spécifications de sécurité des matériaux (MSDS) et les instructions du fabricant concernant les métaux, les consommables, les revêtements, les nettoyants et les dégraissants.
- Travailler dans un espace fermé seulement s'il est bien ventilé ou en portant un respirateur à alimentation d'air. Demander toujours à un surveillant dûment formé de se tenir à proximité. Des fumées et des gaz de soudage peuvent déplacer l'air et abaisser le niveau d'oxygène provoquant des blessures ou des accidents mortels. S'assurer que l'air de respiration ne présente aucun danger.
- Ne pas souder dans des endroits situés à proximité d'opérations de dégraissage, de nettoyage ou de pulvérisation. La chaleur et les rayons de l'arc peuvent réagir en présence de vapeurs et former des gaz hautement toxiques et irritants.
- Ne pas souder des métaux munis d'un revêtement, tels que l'acier galvanisé, plaqué en plomb ou au cadmium à moins que le revêtement n'ait été enlevé dans la zone de soudure, que l'endroit soit bien ventilé, et en portant un respirateur à alimentation d'air. Les revêtements et tous les métaux renfermant ces éléments peuvent dégager des fumées toxiques en cas de soudage.



LES RAYONS DE L'ARC peuvent provoquer des brûlures dans les yeux et sur la peau.

Le rayonnement de l'arc du procédé de soudage génère des rayons visibles et invisibles intense (ultraviolets et infrarouges) susceptibles de provoquer des brûlures dans les yeux et sur la peau. Des étincelles sont projetées pendant le soudage.

- Porter un casque de soudage approuvé muni de verres filtrants approprié pour protéger visage et yeux pendant le soudage (voir ANSI Z49.1 et Z87.1 énuméré dans les normes de sécurité).
- Porter des lunettes de sécurité avec écrans latéraux même sous votre casque.
- Avoir recours à des écrans protecteurs ou à des rideaux pour protéger les autres contre les rayonnements les éblouissements et les étincelles ; prévenir toute personne sur les lieux de ne pas regarder l'arc.
- Porter des vêtements confectionnés avec des matières résistantes et ignifuges (cuir, coton lourd ou laine) et des bottes de protection.



LE SOUDAGE peut provoquer un incendie ou une explosion.

Le soudage effectué sur des conteneurs fermés tel que des réservoirs, tambours ou des conduites peut provoquer leur éclatement. Des étincelles peuvent être projetées de l'arc de soudure. La projection d'étincelles, des pièces chaudes et des équipements chauds peut provoquer des incendies et des brûlures. Le contact accidentel de l'électrode avec des objets métalliques peut provoquer des étincelles, une explosion, un surchauffement ou un incendie. Avant de commencer le soudage, vérifier et s'assurer que l'endroit ne présente pas de danger.

- Déplacer toutes les substances inflammables à une distance de 10,7 m de l'arc de soudage. En cas d'impossibilité les recouvrir soigneusement avec des protections homologués.
- Ne pas souder dans un endroit où des étincelles peuvent tomber sur des substances inflammables.
- Se protéger et d'autres personnes de la projection d'étincelles et de métal chaud.
- Des étincelles et des matériaux chauds du soudage peuvent facilement passer dans d'autres zones en traversant de petites fissures et des ouvertures.
- Surveiller tout déclenchement d'incendie et tenir un extincteur à proximité.
- Le soudage effectué sur un plafond, plancher, paroi ou séparation peut déclencher un incendie de l'autre côté.
- Ne pas effectuer le soudage sur des conteneurs fermés tels que des réservoirs, tambours, ou conduites, à moins qu'ils n'aient été préparés correctement conformément à AWS F4.1 (voir les normes de sécurité).
- Ne soudez pas si l'air ambiant est chargé de particules, gaz, ou vapeurs inflammables (vapeur d'essence, par exemple).
- Brancher le câble de masse sur la pièce la plus près possible de la zone de soudage pour éviter le transport du courant sur une longue distance par des chemins inconnus éventuels en provoquant des risques d'électrocution, d'étincelles et d'incendie.
- Ne pas utiliser le poste de soudage pour dégeler des conduites gelées.
- En cas de non utilisation, enlever la baguette d'électrode du porte-électrode ou couper le fil à la pointe de contact.
- Porter des vêtements de protection dépourvus d'huile tels que des gants en cuir, une chemise en matériau lourd, des pantalons sans revers, des chaussures hautes et un couvre chef.
- Avant de souder, retirer toute substance combustible de vos poches telles qu'un allumeur au butane ou des allumettes.
- Une fois le travail achevé, assurez-vous qu'il ne reste aucune trace d'étincelles incandescentes ni de flammes.
- Utiliser exclusivement des fusibles ou coupe-circuits appropriés. Ne pas augmenter leur puissance; ne pas les ponter.
- Une fois le travail achevé, assurez-vous qu'il ne reste aucune trace d'étincelles incandescentes ni de flammes.
- Utiliser exclusivement des fusibles ou coupe-circuits appropriés. Ne pas augmenter leur puissance; ne pas les ponter.
- Suivre les recommandations dans OSHA 1910.252(a)(2)(iv) et NFPA 51B pour les travaux à chaud et avoir de la surveillance et un extincteur à proximité.

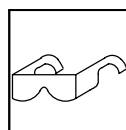

DES PIÈCES DE METAL ou DES SALETES peuvent provoquer des blessures dans les yeux.

- Le soudage, l'écaillage, le passage de la pièce à la brosse en fil de fer, et le meulage génèrent des étincelles et des particules métalliques volantes. Pendant la période de refroidissement des soudures, elles risquent de projeter du laitier.
- Porter des lunettes de sécurité avec écrans latéraux ou un écran facial.



LES ACCUMULATIONS DE GAZ risquent de provoquer des blessures ou même la mort.

- Fermer l'alimentation du gaz protecteur en cas de non-utilisation.
- Veiller toujours à bien aérer les espaces confinés ou se servir d'un respirateur d'adduction d'air homologué.



LES CHAMPS MAGNETIQUES peuvent affecter des implants médicaux.

- Porteur de simulateur cardiaque ou autre implants médicaux, rester à distance.
- Les porteurs d'implants doivent d'abord consulter leur médecin avant de s'approcher des opérations de soudage à l'arc, de soudage par points, de gougeage, du coupage plasma ou de chauffage par induction.

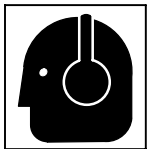

LE BRUIT peut endommager l'ouïe.

Le bruit des processus et des équipements peut affecter l'ouïe.

- Porter des protections approuvées pour les oreilles si le niveau sonore est trop élevé.

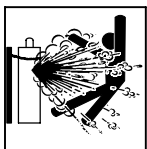

LES BOUTEILLES peuvent exploser si elles sont endommagées.

Des bouteilles de gaz protecteur contiennent du gaz sous haute pression. Si une bouteille est endommagée, elle peut exploser. Du fait que les bouteilles de gaz font normalement partie du procédé de soudage, les manipuler avec précaution.

- Protéger les bouteilles de gaz comprimé d'une chaleur excessive, des chocs mécaniques, des dommages physiques, du laitier, des flammes ouvertes, des étincelles et des arcs.
- Placer les bouteilles debout en les fixant dans un support stationnaire ou dans un porte-bouteilles pour les empêcher de tomber ou de se renverser.
- Tenir les bouteilles éloignées des circuits de soudage ou autres circuits électriques.
- Ne jamais placer une torche de soudage sur une bouteille à gaz.
- Une électrode de soudage ne doit jamais entrer en contact avec une bouteille.
- Ne jamais souder une bouteille pressurisée – risque d'explosion.
- Utiliser seulement des bouteilles de gaz protecteur, régulateurs, tuyaux et raccords convenables pour cette application spécifique ; les maintenir ainsi que les éléments associés en bon état.
- Détourner votre visage du détendeur-régulateur lorsque vous ouvrez la soupape de la bouteille.
- Le couvercle du détendeur doit toujours être en place, sauf lorsque la bouteille est utilisée ou qu'elle est reliée pour usage ultérieur.
- Utiliser les équipements corrects, les bonnes procédures et suffisamment de personnes pour soulever et déplacer les bouteilles.
- Lire et suivre les instructions sur les bouteilles de gaz comprimé, l'équipement connexe et le dépliant P-1 de la CGA (Compressed Gas Association) mentionné dans les principales normes de sécurité.

2-3. Dangers supplémentaires en relation avec l'installation, le fonctionnement et la maintenance



Risque D'INCENDIE OU D'EXPLOSION.

- Ne pas placer l'appareil sur, au-dessus ou à proximité de surfaces inflammables.
- Ne pas installer l'appareil à proximité de produits inflammables.
- Ne pas surcharger l'installation électrique – s'assurer que l'alimentation est correctement dimensionnée et protégée avant de mettre l'appareil en service.

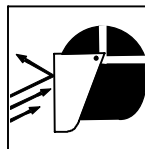

LES ÉTINCELLES VOLANTES risquent de provoquer des blessures.

- Porter un écran facial pour protéger le visage et les yeux.
- Affûter l'électrode au tungstène uniquement à la meuleuse dotée de protecteurs. Cette manœuvre est à exécuter dans un endroit sûr lorsque l'on porte l'équipement homologué de protection du visage, des mains et du corps.
- Les étincelles risquent de causer un incendie – éloigner toute substance inflammable.



LA CHUTE DE L'APPAREIL peut blesser.

- Utiliser l'anneau de levage uniquement pour soulever l'appareil, NON PAS les chariots, les bouteilles de gaz ou tout autre accessoire.
- Utiliser un équipement de levage de capacité suffisante pour lever l'appareil.
- En utilisant des fourches de levage pour déplacer l'unité, s'assurer que les fourches sont suffisamment longues pour dépasser du côté opposé de l'appareil.

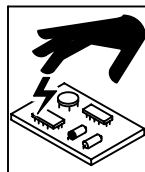

LES CHARGES ÉLECTROSTATIQUES peuvent endommager les circuits imprimés.

- Établir la connexion avec la barrette de terre avant de manipuler des cartes ou des pièces.
- Utiliser des pochettes et des boîtes antistatiques pour stocker, déplacer ou expédier des cartes de circuits imprimés.

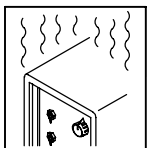

L'EMPLOI EXCESSIF peut SURCHAUFFER L'ÉQUIPEMENT.

- Prévoir une période de refroidissement ; respecter le cycle opératoire nominal.
- Réduire le courant ou le facteur de marche avant de poursuivre le soudage.
- Ne pas obstruer les passages d'air du poste.

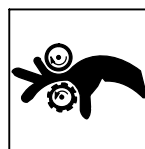

DES ORGANES MOBILES peuvent provoquer des blessures.

- Ne pas s'approcher des organes mobiles.
- Ne pas s'approcher des points de coincement tels que des rouleaux de commande.



LES FILS DE SOUDAGE peuvent provoquer des blessures.

- Ne pas appuyer sur la gâchette avant d'en avoir reçu l'instruction.
- Ne pas diriger le pistolet vers soi, d'autres personnes ou toute pièce mécanique en engageant le fil de soudage.



DES ORGANES MOBILES peuvent provoquer des blessures.

- S'abstenir de toucher des organes mobiles tels que des ventilateurs.
- Maintenir fermés et verrouillés les portes, panneaux, recouvrements et dispositifs de protection.
- Seules des personnes qualifiées sont autorisées à enlever les portes, panneaux, recouvrements ou dispositifs de protection pour l'entretien.
- Remettre les portes, panneaux, recouvrements ou dispositifs de protection quand l'entretien est terminé et avant de rebrancher l'alimentation électrique.



LIRE LES INSTRUCTIONS.

- Lisez le manuel d'instructions avant l'utilisation ou la maintenance de l'appareil.
- N'utiliser que les pièces de rechange recommandées par le constructeur.
- Effectuer régulièrement le contrôle et l'entretien de l'installation.
- Maintenir soigneusement fermés les portes et les panneaux des sources de haute fréquence, maintenir les éclateurs à une distance correcte et utiliser une terre et un blindage pour réduire les interférences éventuelles.

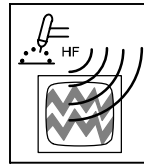

LE RAYONNEMENT HAUTE FRÉQUENCE (H.F.) risque de provoquer des interférences.

- Le rayonnement haute fréquence (H.F.) peut provoquer des interférences avec les équipements de radio-navigation et de communication, les services de sécurité et les ordinateurs.
- Demander seulement à des personnes qualifiées familiarisées avec des équipements électroniques de faire fonctionner l'installation.
- L'utilisateur est tenu de faire corriger rapidement par un électricien qualifié les interférences résultant de l'installation.
- Si le FCC signale des interférences, arrêter immédiatement l'appareil.



LE SOUDAGE À L'ARC risque de provoquer des interférences.

- L'énergie électromagnétique risque de provoquer des interférences pour l'équipement électronique sensible tel que les ordinateurs et l'équipement commandé par ordinateur tel que les robots.
- Veiller à ce que tout l'équipement de la zone de soudage soit compatible électromagnétiquement.
- Pour réduire la possibilité d'interférence, maintenir les câbles de soudage aussi courts que possible, les grouper, et les poser aussi bas que possible (ex. par terre).
- Veiller à souder à une distance de 100 mètres de tout équipement électronique sensible.
- Veiller à ce que ce poste de soudage soit posé et mis à la terre conformément à ce mode d'emploi.
- En cas d'interférences après avoir pris les mesures précédentes, il incombe à l'utilisateur de prendre des mesures supplémentaires telles que le déplacement du poste, l'utilisation de câbles blindés, l'utilisation de filtres de ligne ou la pose de protecteurs dans la zone de travail.

2-4. Proposition californienne 65 Avertissements

⚠ Les équipements de soudage et de coupage produisent des fumées et des gaz qui contiennent des produits chimiques dont l'État de Californie reconnaît qu'ils provoquent des malformations congénitales et, dans certains cas, des cancers. (Code de santé et de sécurité de Californie, chapitre 25249.5 et suivants)

⚠ Les batteries, les bornes et autres accessoires contiennent du plomb et des composés à base de plomb, produits chimiques dont l'État de Californie reconnaît qu'ils provoquent des cancers et des malformations congénitales ou autres problèmes de procréation. Se laver les mains après manipulation.

Pour les moteurs à essence :

⚠ Les gaz d'échappement des moteurs contiennent des produits chimiques dont l'État de Californie reconnaît qu'ils provoquent des cancers et des malformations congénitales ou autres problèmes de procréation.

Pour les moteurs diesel :

⚠ Les gaz d'échappement des moteurs diesel et certains de leurs composants sont reconnus par l'État de Californie comme provoquant des cancers et des malformations congénitales ou autres problèmes de procréation.

2-5. Principales normes de sécurité

Safety in Welding, Cutting, and Allied Processes, ANSI Standard Z49.1, de Global Engineering Documents (téléphone : 1-877-413-5184, site Internet : www.global.ihc.com).

Recommended Safe Practices for the Preparation for Welding and Cutting of Containers and Piping, American Welding Society Standard AWS F4.1 de Global Engineering Documents (téléphone : 1-877-413-5184, site Internet : www.global.ihc.com).

National Electrical Code, NFPA Standard 70, de National Fire Protection Association, P.O. Box 9101, Quincy, MA 02269-9101 (téléphone : 617-770-3000, site Internet : www.nfpa.org).

Safe Handling of Compressed Gases in Cylinders, CGA Pamphlet P-1, de Compressed Gas Association, 4221 Walney Road, 5th Floor, Chantilly, VA 20151 (téléphone : 703-788-2700, site Internet : www.cganet.com).

Code for Safety in Welding and Cutting, CSA Standard W117.2, de Canadian Standards Association, 5060 Mississauga, Ontario, Canada

L4W 5NS (téléphone : 800-463-6727 ou à Toronto 416-747-4044, site Internet : www.csa-international.org).

Safe Practice For Occupational And Educational Eye And Face Protection, ANSI Standard Z87.1, de American National Standards Institute, 11 West 43rd Street, New York, NY 10036-8002 (téléphone : 212-642-4900, site Internet : www.ansi.org).

Standard for Fire Prevention During Welding, Cutting, and Other Hot Work, NFPA Standard 51B, de National Fire Protection Association, P.O. Box 9101, Quincy, MA 02269-9101 (téléphone : 617-770-3000, site Internet : www.nfpa.org).

OSHA, Occupational Safety and Health Standards for General Industry, Title 29, Code of Federal Regulations (CFR), Part 1910, Subpart Q, and Part 1926, Subpart J, de U.S. Government Printing Office, Superintendent of Documents, P.O. Box 371954, Pittsburgh, PA 15250-7954 (téléphone : 1-866-512-1800) (il y a 10 bureaux régionaux—le téléphone de la région 5, Chicago, est 312-353-2220, site Internet : www.osha.gov).

2-6. Information EMF

Considérations sur le soudage et les effets de basse fréquence et des champs magnétiques et électriques.

Le courant de soudage, pendant son passage dans les câbles de soudage, causera des champs électromagnétiques. Il y a eu et il y a encore un certain souci à propos de tels champs. Cependant, après avoir examiné plus de 500 études qui ont été faites pendant une période de recherche de 17 ans, un comité spécial ruban bleu du National Research Council a conclu : « L'accumulation de preuves, suivant le jugement du comité, n'a pas démontré que l'exposition aux champs magnétiques et champs électriques à haute fréquence représente un risque à la santé humaine ». Toutefois, des études sont toujours en cours et les preuves continuent à être examinées. En attendant que les conclusions finales de la recherche soient établies, il vous serait souhaitable de réduire votre exposition aux champs électromagnétiques pendant le soudage ou le coupage.

Pour réduire les champs magnétiques sur le poste de travail, appliquer les procédures suivantes :

1. Garder les câbles ensemble, les torsader, les scotcher, ou les recouvrir d'une housse.
2. Disposer les câbles d'un côté et à distance de l'opérateur.
3. Ne pas courber pas et ne pas entourer pas les câbles autour de votre corps.
4. Garder le poste de soudage et les câbles le plus loin possible de vous.
5. Connecter la pince sur la pièce aussi près que possible de la soudure.

En ce qui concerne les implants médicaux :

Les porteurs d'implants doivent d'abord consulter leur médecin avant de s'approcher des opérations de soudage à l'arc, de soudage par points, de gougeage, du coupage plasma ou de chauffage par induction. Si le médecin approuve, il est recommandé de suivre les procédures précédentes.

SECTION 3 – DEFINITIONS

3-1. WEEE Label (For Products Sold Within The EU)

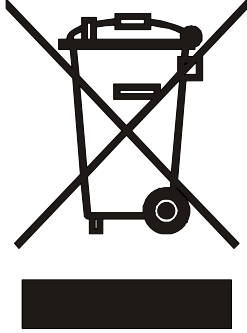
	<p>Do not discard product (where applicable) with general waste.</p> <p>Reuse or recycle Waste Electrical and Electronic Equipment (WEEE) by disposing at a designated collection facility.</p> <p>Contact your local recycling office or your local distributor for further information.</p>
---	---

3-2. Symbols And Definitions

U₁	Primary Voltage	V	Volts	I₁	Primary Current	A	Amperes
IP	Degree Of Protection	U₂	Conventional Load Voltage	I₂	Rated Welding Current	X	Duty Cycle
%	Percent						

SECTION 4 – INSTALLATION

4-1. Specifications

Wire Diameter Range	Approximate Wire Feed Range	Cooling Method	Maximum Spool Size	Weld Circuit Rating	IP Rating	Overall Dimensions	Weight
.025 Thru 1/16 in. (0.6 Thru 1.6 mm) Aluminum Wire .025 Thru .045 in. (0.6 Thru 1.1 mm) Hard Or Cored Wire	70 To 875 ipm (1.7 To 22.2 mpm)	Air Cooled	4 in. (102 mm) Diameter	100 Volts, 200 Amperes, 100% Duty Cycle Using Argon Shielding Gas	IP 23	Length: 15-3/8 in. (390 mm) Width: 2-1/2 in. (64 mm) Height: 10-3/4 in. (273 mm)	2.9 lb (1.3 kg) Gun Only 15A Model: 9 lb (4.1 kg) Gun With Cable 30A Model: 14 lb (6.4 kg) Gun With Cable

☞ Use weld control or welding power source Owner's Manual during gun installation. If contact tip, liner, and drive roll groove are not correct for wire size and type, see Section 6 to change parts as needed. See Parts List for other available contact tips.

4-2. Removing Top Cover

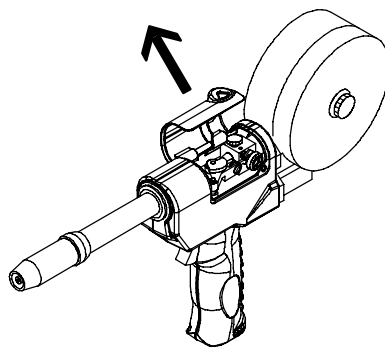
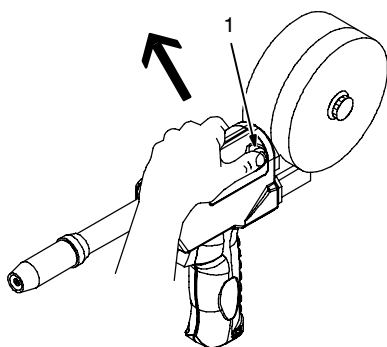

1 Top Cover Triangular Boss

Push up on triangular boss to open door. Door hinges on handle.

To open door fully, push up on door until it clicks into position.

☞ If door is pushed too far it will separate from handle. If this happens the door can be reinstalled.

Push door back into original position to close.

150 882-G

4-3. Installing Wire Spool And Threading Welding Wire

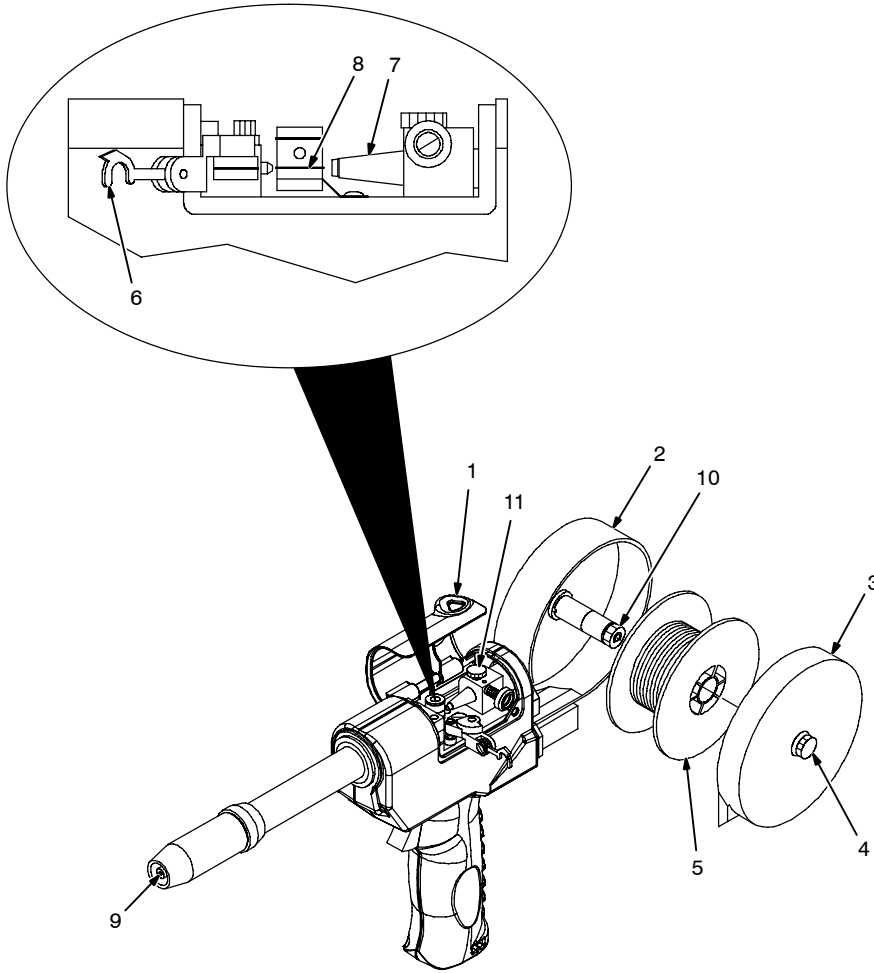

- 1 Top Cover
- 2 Canister
- 3 Canister Cover
- 4 Thumbscrew (Canister Cover)

Loosen thumbscrew and remove cover.

- 5 Wire Spool

Loosen wire from spool, cut off bent wire, and pull 6 in (150 mm) of wire off spool.

- 6 Pressure Roll Assembly

Lift arm and open pressure roll assembly.

- 7 Canister Inlet Guide

- 8 Drive Roll Groove

⚠ For wire sizes .035 in (0.9 mm) and smaller use small groove, and .047 in. (1.2 mm) and 1/16 in. (1.6 mm) use large groove.

- 9 Contact Tip

Thread wire through canister inlet guide, along drive roll groove, and out contact tip.

Install spool so wire feeds off bottom.

- 10 Spool Brake Thumbnut

If necessary, turn thumbnut counterclockwise slightly to install spool.

- 11 Thumbscrew (Canister Rotation)

Loosen thumbscrew to rotate canister (see Section 4-4).

Close and secure pressure roll assembly.

Reinstall top cover and canister cover.

Tools Needed:



150 436-F

4-4. Rotating Canister

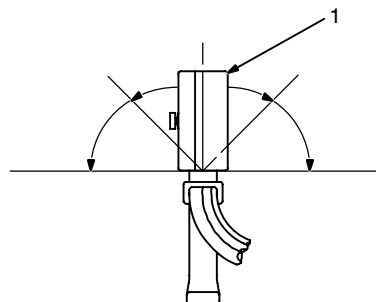

Rear View

- 1 Canister

Loosen canister rotation thumbscrew (see Section 4-3). Move canister to desired position. Tighten thumbscrew.

150 433-A

4-5. Connecting To 24 Volt Weld Control

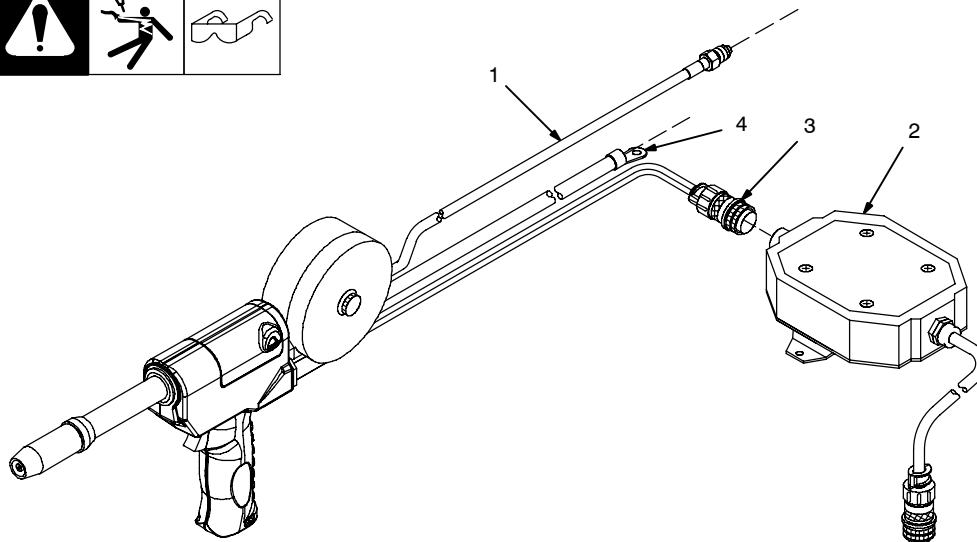

- 1 Gas Hose
Connect fitting to regulator/flowmeter (see Section 4-7).
- 2 24 Volt Weld Control
Insert plug into receptacle, and tighten threaded collar.
- 3 Trigger Control Cord
Insert plug into receptacle, and tighten threaded collar.
- 4 Weld Cable
Connect to positive (+) weld output terminal on welding power source according to its Owner's Manual.

Tools Needed:



150 917-G

4-6. Connecting To 115 Volt Weld Control

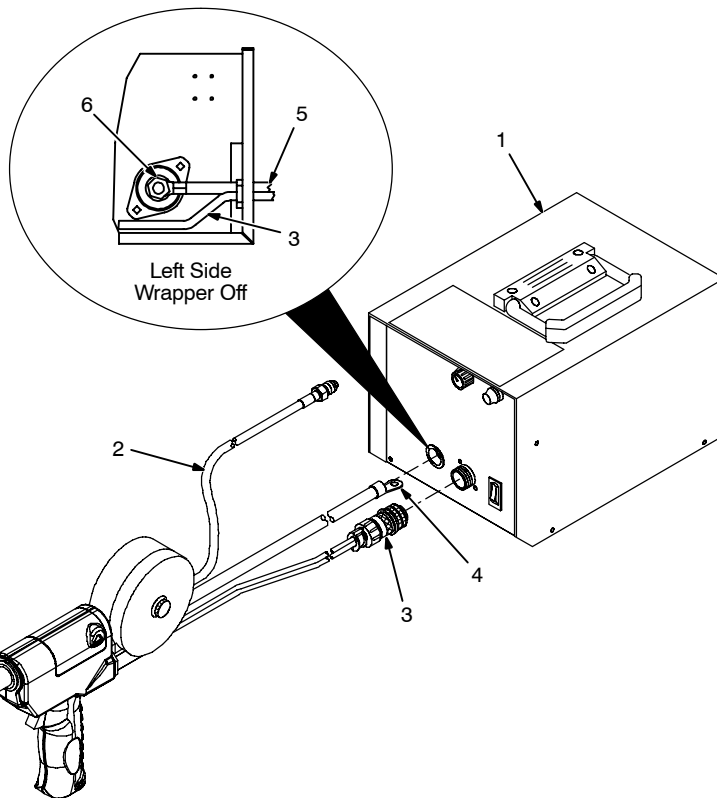

- 1 115 Volt Weld Control
Connect to regulator/flowmeter.
- 2 Gas Hose
Connect to regulator/flowmeter.
- 3 Trigger Control Cord
Insert plug into receptacle, and tighten threaded collar.
- 4 Weld Cable
Connect to positive (+) weld output terminal in weld control.
- 5 Positive (+) Weld Output Terminal In Control
Reinstall weld control wrapper.

Tools Needed:



Ref. 149 549-A / 149 966-J

4-7. Installing Gas Supply

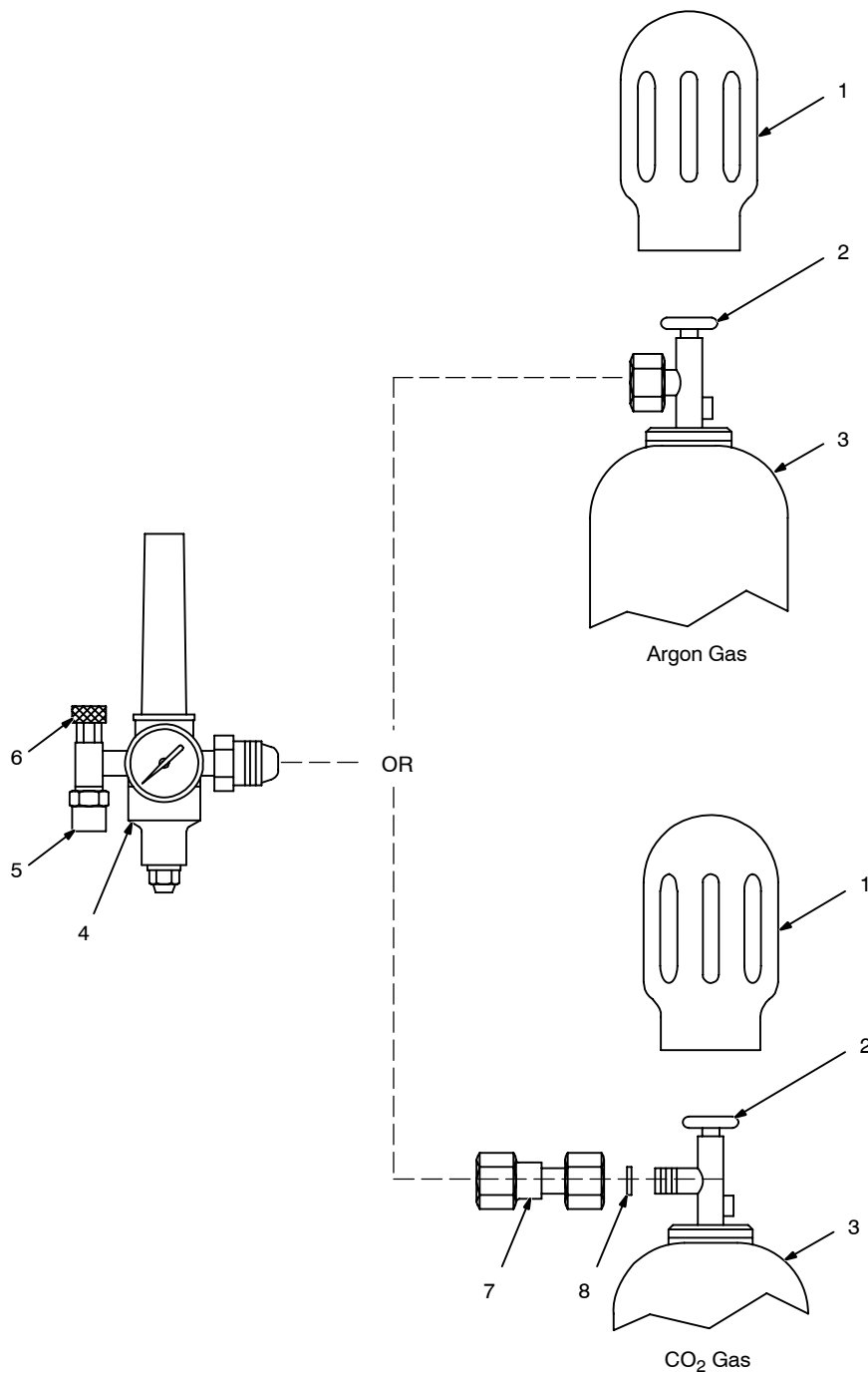

Obtain gas cylinder and chain to running gear, wall, or other stationary support so cylinder cannot fall and break off valve.

- 1 Cap
- 2 Cylinder Valve

Remove cap, stand to side of valve, and open valve slightly. Gas flow blows dust and dirt from valve. Close valve.

- 3 Cylinder
 - 4 Regulator/Flowmeter
- Install so face is vertical.

5 Gas Hose Connection
Fitting has 5/8-18 right-hand threads.

- 6 Flow Adjust

Typical flow rate is 20 cfh (cubic feet per hour). Check wire manufacturer's recommended flow rate.

Make sure flow adjust is closed when opening cylinder to avoid damage to the flowmeter.

- 7 CO₂ Adapter

- 8 O-Ring

Install adapter with O-ring between regulator/flowmeter and CO₂ cylinder.

Tools Needed:

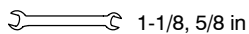

4-8. Adjusting Drive Roll And Spool Brake Pressure

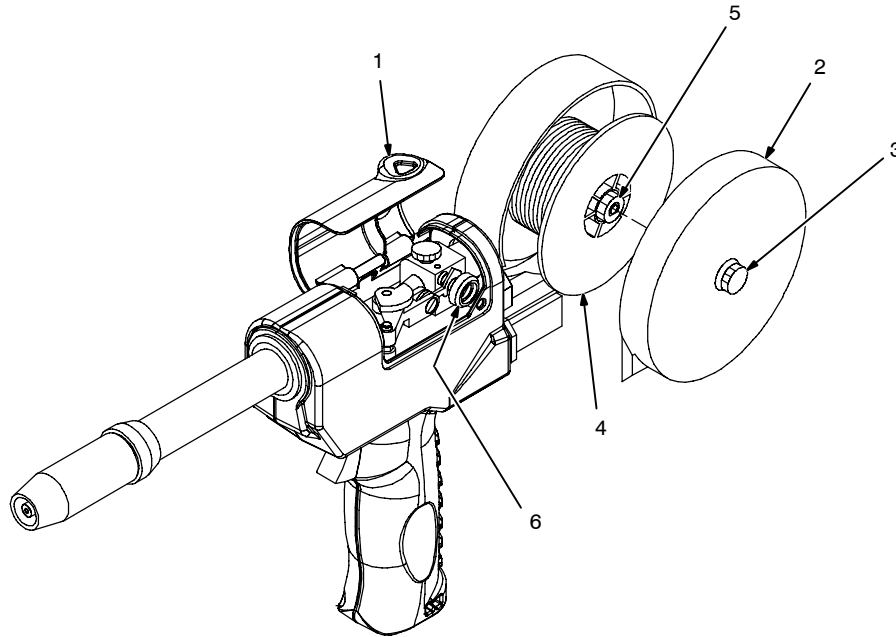

- 1 Top Cover
- 2 Canister Cover
- 3 Thumbscrew

Loosen thumbscrew and remove cover.

- 4 Spool

Cut welding wire off at contact tip. Retract wire onto spool and secure.

- 5 Spool Brake Thumbnut

Grasp spool in one hand and turn while adjusting spool brake thumbnut. When a slight force is needed to turn spool, tension is set. Do not overtighten.

Reinstall canister cover. Thread welding wire (see Section 4-3).

- 6 Drive Roll Tension Thumbnut

Turn On unit and check drive roll pressure by feeding wire against a wood board or concrete surface; wire should feed steadily without slipping.

Adjust drive roll tension thumbnut if necessary. Do not overtighten.

Turn Off unit. Reinstall top cover.

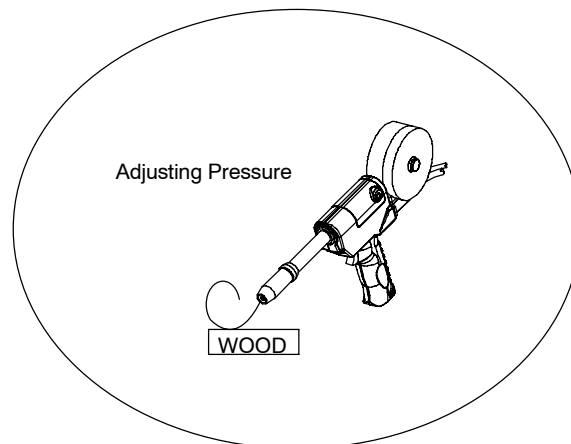

Tools Needed:



Ref. 151 112-F / 147 741-F

SECTION 5 – OPERATION

5-1. Controls

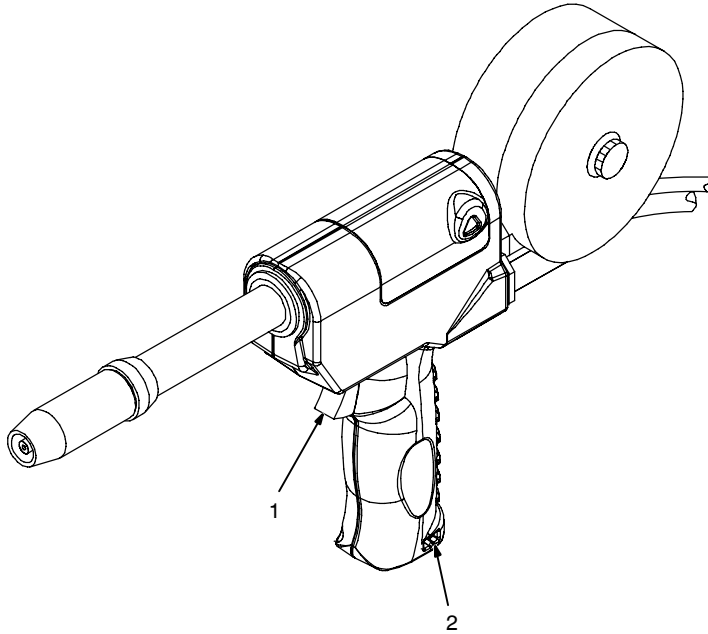

1 Trigger

Press trigger to energize welding power source contactor (if applicable), start shielding gas flow, and begin wire feed.

For shielding gas preflow and post-flow, lightly press trigger before and after welding.

2 Wire Speed Control

Use control to adjust wire feed speed. The numbers in the opening are not a wire feed speed and are for reference only.

Ref. 147 741-F

5-2. Shielding Gas

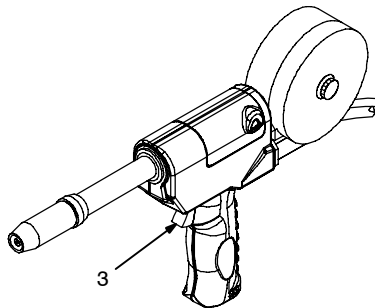
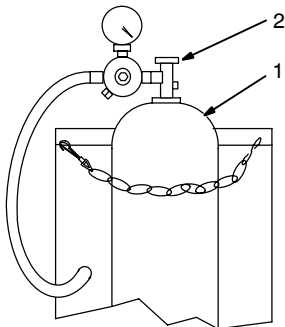

1 Shielding Gas Cylinder

2 Valve

3 Gun Trigger

Open valve on cylinder just before welding.









Gun trigger turns weld output and gas flow on and off. For shielding gas preflow and postflow, lightly press trigger before and after welding.

Close valve on cylinder when finished welding.

sb5.1* 6/92 – S-0621-C / Ref. 147 741-F

SECTION 6 – MAINTENANCE & TROUBLESHOOTING

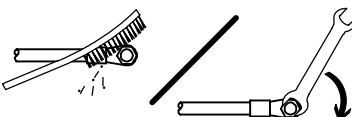
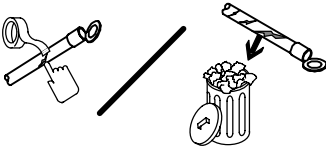
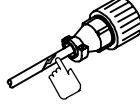
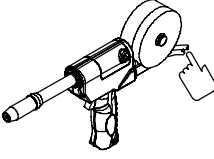
6-1. Routine Maintenance

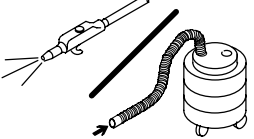
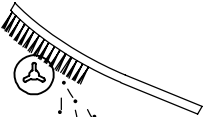
					 Disconnect power before maintaining.		 <i>Maintain more often during severe conditions.</i>	
 3 Months								
  Replace Damaged Or Unreadable Labels			 Replace Damage Gas Hose			 Clean And Tighten Weld Terminals		
						 Repair Or Replace Cracked Cables And Cords		
 6 Months								
 Blow Out Or Vacuum Inside					 Clean Drive Rolls			

6-2. Changing Gun Contact Tip

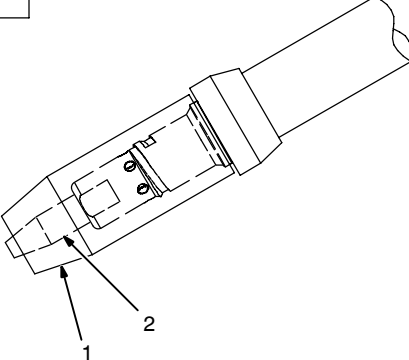
					<p>Remove nozzle</p> <ol style="list-style-type: none"> 1 Nozzle 2 FasTip <p>Unscrew FasTip.</p> <p>Install new FasTip.</p>			
								
Ref. 150 437-A								

6-4. Gun Drive Assembly Maintenance

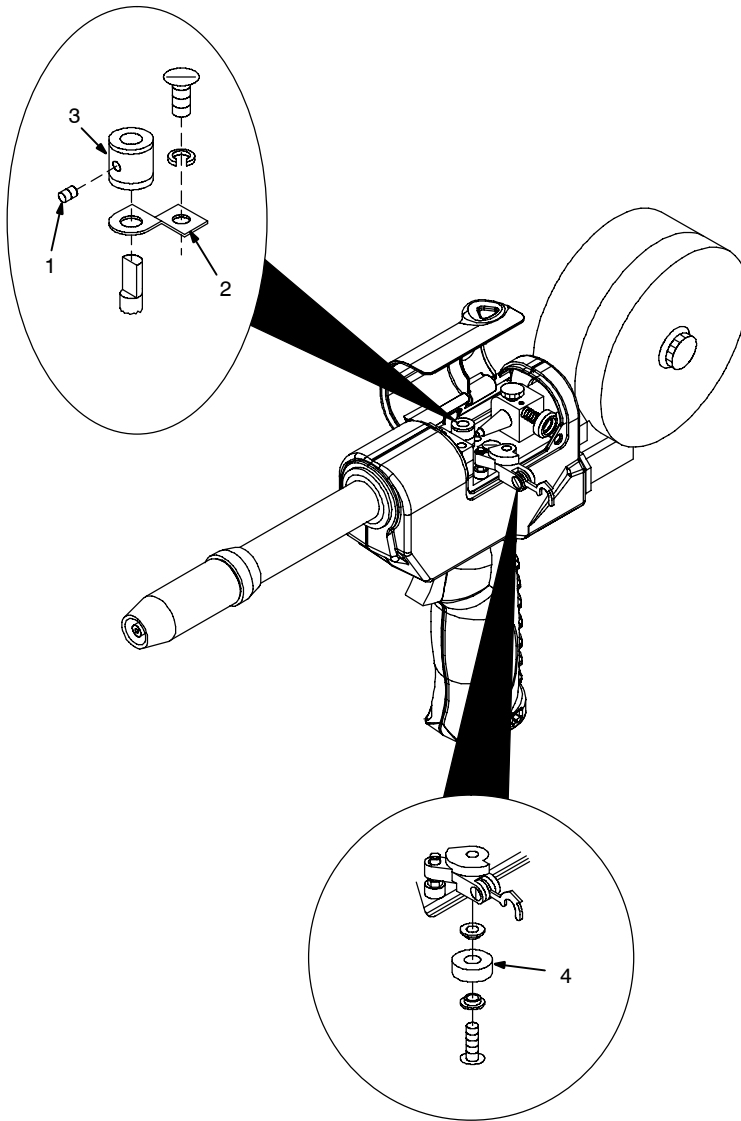

Retract wire onto spool.

- 1 Setscrew
- 2 Current Pick-Up Tab

This tab helps prevent burnback caused by welding arcs inside the contact tip. This tab may be removed to provide an insulated drive roll. (If tab is removed, a smaller diameter contact tip is recommended. See options in Parts List.) Lightly grease top of tab before reinstalling.

- 3 Drive Roll

Use wire brush to clean drive roll. Install drive roll with desired groove down, and turn drive roll so one setscrew faces flat side of shaft.

- 4 Bearing

Use wire brush to clean bearing. Line up drive roll groove with bearing groove and liner opening. Tighten setscrews.

Thread welding wire through gun (see Section 4-3). Close and secure pressure roll assembly. Adjust drive roll pressure, if necessary (see Section 4-8). Reinstall top cover.

Tools Needed:

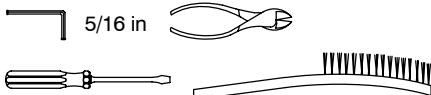

6-5. Replacing Canister Inlet Guide

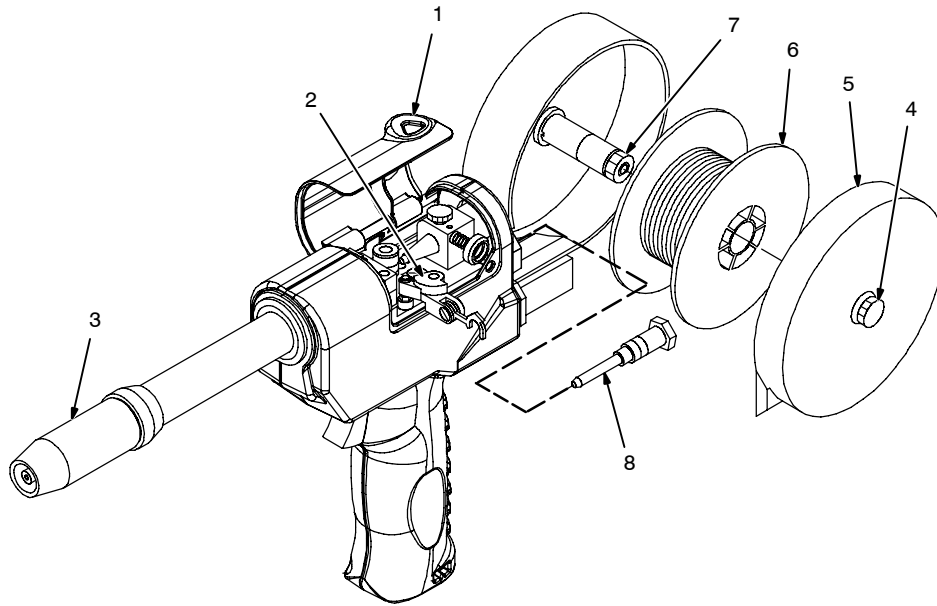
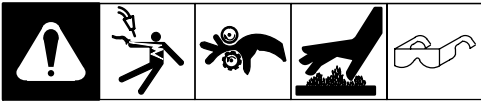

- 1 Top Cover
- 2 Pressure Roll Assembly

Cut off welding wire where it enters pressure roll assembly area.

- 3 Nozzle

Pull wire out nozzle.

- 4 Thumbscrew

- 5 Canister Cover

Loosen thumbscrew and remove cover.

- 6 Wire Spool

- 7 Spool Brake Thumbnut

Loosen thumbnut, retract wire onto spool, secure, and remove spool.

- 8 Canister Inlet Guide

Turn counterclockwise to remove. Install new guide.

Reinstall spool and thread welding wire (see Section 4-3).

Close pressure roll assembly. Adjust spool brake pressure and drive roll pressure if necessary (see Section 4-8).

Reinstall covers.

Tools Needed:



Ref. 150 436-D / Ref. 149 967-H

6-6. Replacing Spool Canister

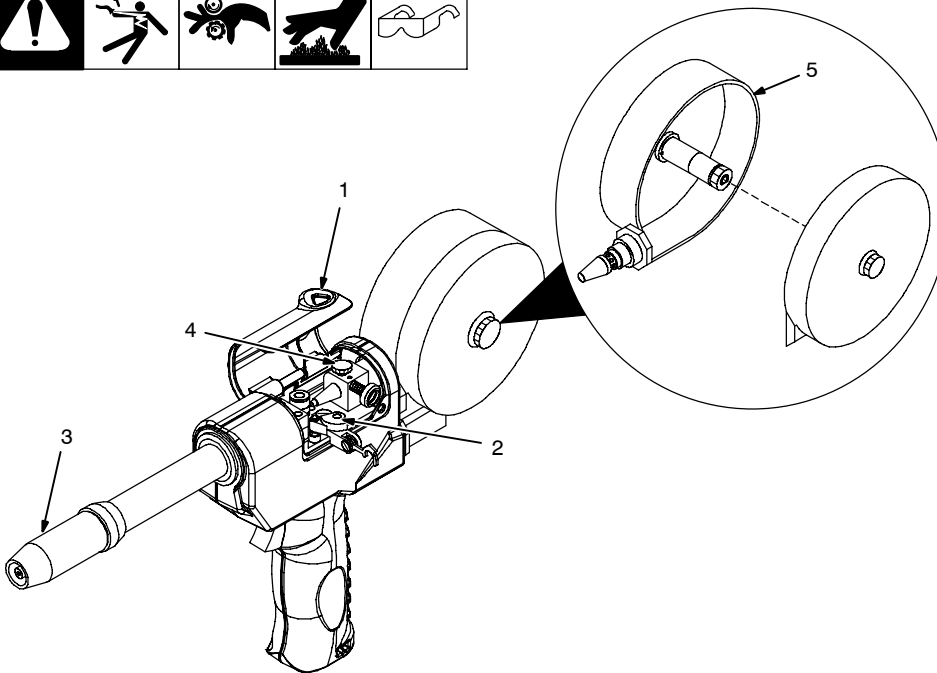

- 1 Top Cover

- 2 Pressure Roll Assembly

Cut off welding wire where it enters pressure roll assembly area.

- 3 Nozzle

Pull wire out nozzle.

- 4 Thumbscrew (Canister Rotation)

Turn thumbscrew counterclockwise three full turns.

- 5 Spool Canister

Remove as shown. Push new canister into wire drive housing until fully seated. Tighten thumbscrew.

Install spool and thread welding wire (see Section 4-3).

Close pressure roll assembly. Adjust spool brake pressure and drive roll pressure as necessary (see Section 4-8).

Reinstall covers.

Tools Needed:



Ref. 149 967-H

6-7. Replacing Diffuser

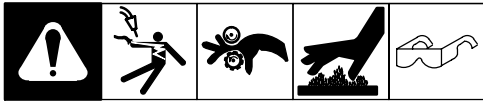

Turn Off welding power source.

1 Nozzle

2 FasTip

To remove, see Section 6-2.

3 Diffuser

Remove diffuser and replace.

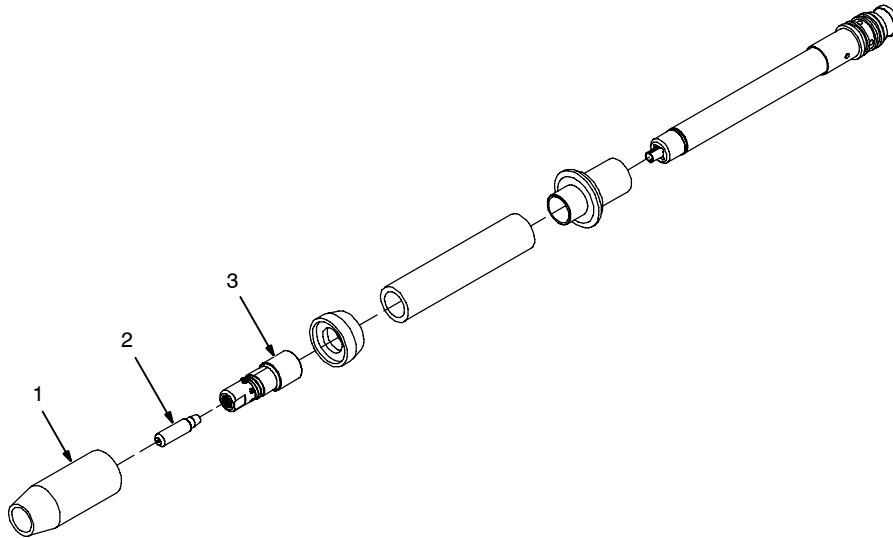

Tools Needed:

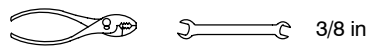

Ref. 803 348-G

6-8. Troubleshooting

Trouble	Remedy
No weld output; gun/feeder does not work.	Secure weld control plug in 115 volts AC receptacle (see weld control Owner's Manual).
	Place Power switch on welding power source in the On position (see welding power source Owner's Manual).
Erratic weld output.	Tighten and clean all connections.
Pressing gun/feeder trigger does not energize weld control; welding wire is not energized; shielding gas does not flow.	Secure plug from gun/feeder trigger cord into 10-socket receptacle on weld control (see Sections 4-5 and 4-6).
Wire feeds, shielding gas flows, but welding wire is not energized.	Secure control cable leads in weld control (see weld control Owner's Manual).
	See Troubleshooting section in welding power source Owner's Manual.
Wire feeds erratically.	Check and correct drive roll pressure (see Section 4-8).
	Clean drive roll or replace drive roll (see Section 6-4).
	Decrease spool brake pressure (see Section 4-8).

SECTION 7 – ELECTRICAL DIAGRAM

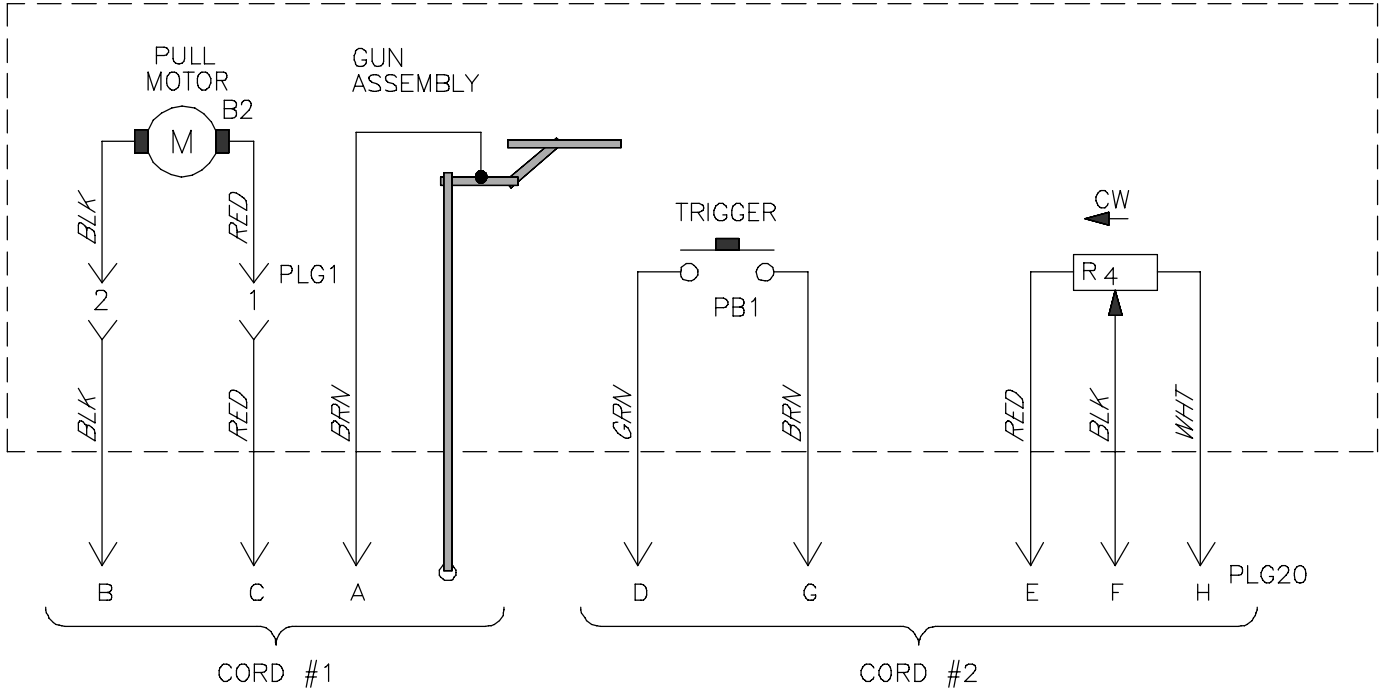

⚠ WARNING	<ul style="list-style-type: none"> • Do not touch live electrical parts. • Disconnect input power or stop engine before servicing. • Do not operate with covers removed. • Have only qualified persons install, use, or service this unit.
ELECTRIC SHOCK HAZARD	

195 712-B

Figure 7-1. Circuit Diagram For Gun/Feeder

SECTION 8 - PARTS LIST

 Hardware is common and not available unless listed.

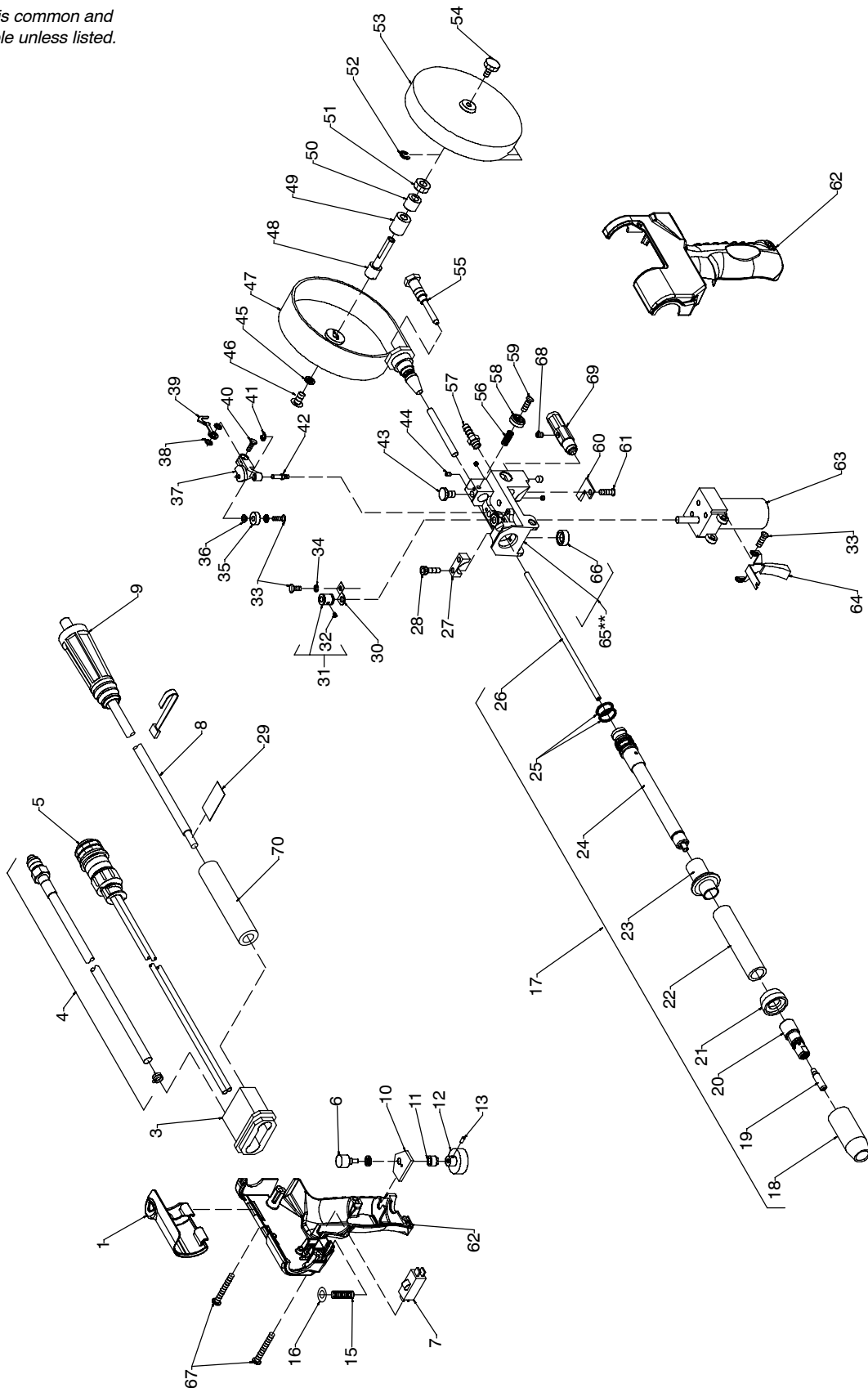

Figure 8-1. Complete Assembly

Ref. 803 707-D

Item No.	Dia. Mkgs.	Part No.	Description	Quantity
----------	------------	----------	-------------	----------

Figure 8-1. Complete Assembly

1		214 745	Cover (Included With Item 62)	1
2		Deleted		
3		133 362	Strain Relief, Cable	1
4		210 538	Hose, Gas In	1
5		210 539	Cable, Control 50 Ft (Includes)	1
6	R4	200 096	Potentiometer, C Sltd Sft 1/T .5W 10K Ohm	1
7	PB1	000 369	Switch, Lim 10A 125/250VAC Dpst Plgr	1
		190 294	Conn, Circ Ms/Cpc 10 Pin	1
		143 922	Conn, Circ Cpc Clamp Str Rif	1
8		238 126	Cable, Power 10 Ft	1
9		191 981	Connector, Tw Lk Insul Male (Tweco/Lenco)	1
10		144 861	Washer, Anti-turn	1
11		135 127	Lock, Shaft Pot .250-32 X .125Dia Shaft	1
12		134 856	Knob, Speed Control 1-10 .140 Shaft X 1.125 Od	1
13		602 169	Screw, Set Stl Sch 8-32 X .187 Cup Pt	1
14		Deleted		
15		183 884	Spring, Cprsn .240 Od X .026 Wire X 1.000	1
16		184 101	Washer, Shldr .140 Id X .250 Od	1
17		231 531	Head Tube Assy, Air Cooled Pistol (Includes)	1
18		199 613	Nozzle, Brass 5/8 In Orifice Tapered	1
19			Tip, Fastip (See Section 9)	1
20		227 749	Diffuser, .281/.312 Od Collar Fastip 1/8 Rec Edge	1
21		232 284	Insulator, Nozzle Collared Diffuser	1
22		219 794	Jacket, Outer Insulating	1
23		219 795	Insulator, Barrel Pistol	1
24		219 796	Head Tube, Air Pistol (Brazed)	1
25		134 800	O-ring, .614 Id X .070 Cs 70 Duro Buna-n	2
26		212 156	Liner, Phos Bronze .030-1/16 Wire X 7.313	1
27		133 365	Clamp, Head Tube	1
28		000 417	Screw, 10-24 X1.000sochd Hex	2
29		235 225	Strip, Cop .010 X 1.500 X .750	1
		604 638	Screw, 6-32 X .375Sochd Hex	3
30		209 342	Kit, Current Pick-Up (Units W/Bearing Block)	1
31		136 135	Roll, Drive Vk Groove .023-1/16 Wire (Includes)	1
31		183 357	Roll, Drive Vk Groove .030/.035 Wire (Includes)	1
31		183 358	Roll, Drive Vk Groove .047/.062 Wire (Includes)	1
32		604 612	Screw, Set Stl Sch 8-32 X .125 Cup Point	2
33		114 045	Screw, 6-32 X .500Hexwhd Slit Stl Slffmg	3
34		602 198	Washer, Lock .141 Id Stl Split	1
35		134 624	Bearing, Flg Nyl .140 Id X .187 Od X .375Flg X .031Thk	2
36		134 623	Bearing, Idler Roll	1
37		132 852	Arm, Pressure	1
38		605 798	Washer, Shldr Nyl .375 Od X .168 Id X .080	2
39		133 083	Spring, Tension Adj Drive Roll	1
40		144 860	Screw, 8-32 X .437Flatd Slit Stl	1
41		058 968	Ring, Retainer E	1
42		135 474	Pin, Hinge	1
43		155 565	Screw, Thumb	1
		134 799	O-ring, .176 Id X .070Cs (Used W/Thumbscrew)	1
44		135 126	Screw, Set 6-32 X .125 Cup Point Sch Stl	1
45		602 209	Washer, Tooth .256 Id Stl Intl	1
46		602 154	Screw, .250-20 X .500hexhd Stl Slffmg	1
47		132 527	Canister, Spool	1
48		148 488	Post, Support Spool	1
49		132 529	Pad, Brake	1
50		148 489	Washer, Anti-turn .380 Id	1
51		132 524	Nut, .375-24 .56Knrl Alum	1

Item No.	Dia. Mkgs.	Part No.	Description	Quantity
----------	------------	----------	-------------	----------

Figure 8-1. Complete Assembly (Continued)

... 52		000 364	.. Ring, Retainer Ext .145 Shaft Grv X .025Thk	1
... 53		132 526	.. Cover, Spool	1
... 54		132 528	.. Screw, Thumb Canister	1
... 55		132 521	.. Guide, Inlet Canister	1
... 56		112 896	.. Spring, Cprsn .240 Od X .020 Wire X .437	1
... 57		135 580	.. Fitting, Gas	2
...		146 555	.. Screw, Set 8-32 X .125 Cup Sch	1
... 58		135 773	.. Nut, 8-32 .56Knrl Stl	1
... 59		143 360	.. Screw, 8-32 X .500Panhd Phl Stl	1
... 60		136 679	.. Clamp, Strain Relief	1
... 61		129 351	.. Screw, 8-32 X .500Hexwhd Slit Stl Slffmg	1
... 62		220 658	.. Case, Gun Lh/Rh (Molded Halves)	1
... 63	B2	230 947	.. Motor, Gear Pm 24 VDC 420 RPM 10.2:1 Ratio W/Conn	1
... 64		164 592	.. Trigger	1
... 65		236 149	.. Kit, Drive Housing/Cable (Includes)	1
... 66		058 262	.. Cap, Valve	1
... 67		217 934	.. Screw, K40x 20 Pan Hd-trx Stl Pld Pt Thread Forming	4
... 68		005 464	.. Screw, Set 250-20x .37 Ovl Pt Sch Stl Pln Nylok	1
... 69		235 753	.. Ftg, Connection Power Weld	1
... 70		235 751	.. Tubing, Silicone Rbr .500 Id X Spool Black	1

To maintain the factory original performance of your equipment, use only Manufacturer's Suggested Replacement Parts. Model and serial number required when ordering parts from your local distributor.

SECTION 9 – PARTS LIST INCLUDING CONSUMABLES

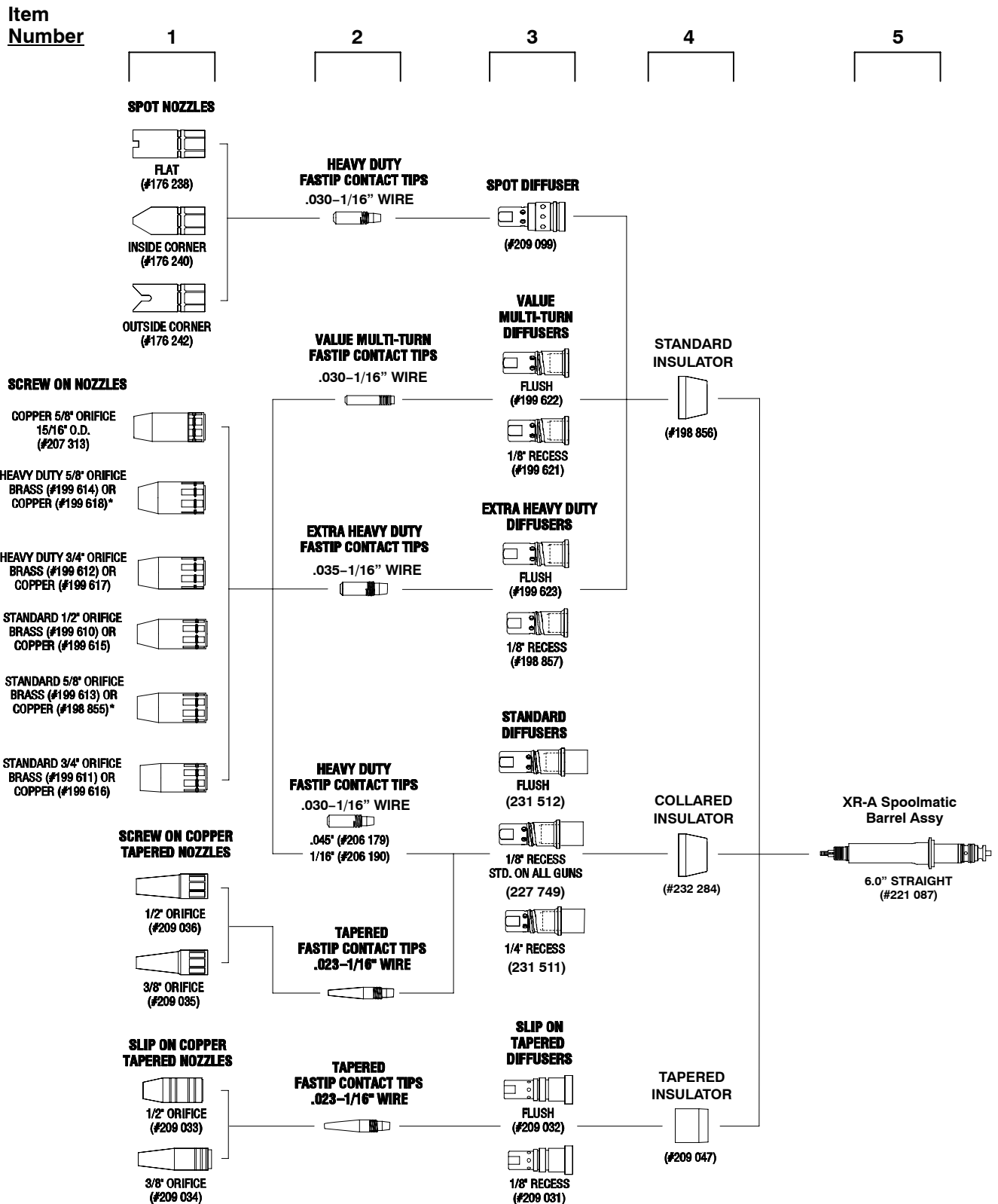

Ref. 803 909-A / 803 932 / 803 933 / 803 934

Figure 9-1. Consumables Flowchart

Item No.	Part No.	Description	Quantity
----------	----------	-------------	----------

Figure 9-1. Consumables Flowchart

Table 9-1. Nozzles

... 1	◆176238	.. Nozzle, Spot Flat (Requires Diffuser 209099, Used With Any Heavy Duty FasTip™ Contact Tip)	1
... 1	◆176240	.. Nozzle, Spot Inside Corner (Requires Diffuser 209099, Used With Any Heavy Duty FasTip™ Contact Tip)	1
... 1	◆176242	.. Nozzle, Spot Outside Corner (Requires Diffuser 209099, Used With Any Heavy Duty FasTip™ Contact Tip)	1
... 1	◆199 610	.. Nozzle, Screw On Brass 1/2 in Orifice	1
... 1	◆199 611	.. Nozzle, Screw On Brass 3/4 in Orifice Straight	1
... 1	◆199 612	.. Nozzle, Screw On Brass 3/4 in Orifice Straight Heavy Duty	1
... 1	◆199 613	.. Nozzle, Screw On Brass 5/8 in Orifice	1
... 1	◆199 614	.. Nozzle, Screw On Brass 5/8 in Orifice Heavy Duty	1
... 1	◆199 615	.. Nozzle, Screw On Copper 1/2 in Orifice	1
... 1	◆199 616	.. Nozzle, Screw On Copper 3/4 in Orifice	1
... 1	◆199 617	.. Nozzle, Screw On Copper 3/4 in Orifice Heavy Duty	1
... 1	198 855	.. Nozzle, Screw On Copper 5/8 in Orifice	1
... 1	199 618	.. Nozzle, Screw On Copper 5/8 in Orifice Heavy Duty	1
... 1	◆207 313	.. Nozzle, Screw On Copper 5/8 in Orifice 15/16 OD	1
... 1	◆209 033	.. Nozzle, Slip On Copper 1/2 in Orifice Tapered (Requires Diffuser 209031 Or 209032 And Insulator 209047, Used With Any Tapered FasTip™ Contact Tip)	1
... 1	◆209 034	.. Nozzle, Slip On Copper 3/8 in Orifice Tapered (Requires Diffuser 209031 Or 209032 And Insulator 209047, Used With Any Tapered FasTip™ Contact Tip)	1
... 1	◆209 035	.. Nozzle, Screw On Copper 3/8 in Orifice Tapered (Requires Diffuser 227 747, 231 511 Or 231 512, Used With Any Tapered FasTip™ Contact Tip)	1
... 1	◆209 036	.. Nozzle, Screw On Copper 1/2 in Orifice Tapered (Requires Diffuser 227 747, 231 511 Or 231 512, Used With Any Tapered FasTip™ Contact Tip)	1

Table 9-2. Heavy Duty FasTip™ Contact Tips*

... 2	◆206 185	.. .030 in (0.8 mm)	1
... 2	◆206 186	.. .035 in (0.9 mm)	1
... 2	◆206 187	.. .040 in (1.0 mm) or .035 in (0.9 mm) Aluminum Wire	1
... 2	206 188	.. .045 in (1.2 mm)	1
... 2	◆206 189	.. .052 in (1.3 mm) or 3/64 in (1.2 mm) Aluminum Wire	1
... 2	206 190	.. 1/16 in (1.6 mm)	1
... 2	◆206 191	.. .068 in (1.7 mm) or 1/16 in (1.6 mm) Aluminum Wire	1

Table 9-3. Extra Heavy Duty FasTip™ Contact Tips*

... 2	◆199 605	.. .035 in (0.9 mm)	1
... 2	◆199 606	.. .040 in (1.0 mm) or .035 in (0.9 mm) Aluminum	1
... 2	◆198 851	.. .045 in (1.2 mm)	1
... 2	◆198 852	.. .052 in (1.3 mm) or 3/64 in (1.2 mm) Aluminum Wire	1
... 2	◆198 853	.. 1/16 in (1.6 mm)	1
... 2	◆198 854	.. .068 in (1.7 mm) or 1/16 in (1.6 mm) Aluminum Wire	1

Table 9-4. Tapered FasTip™ Contact Tips*

... 2	◆209025	.. .030 in (0.8 mm)	1
... 2	◆209026	.. .035 in (0.9 mm)	1
... 2	◆209027	.. .045 in (1.2 mm)	1
... 2	◆209028	.. 3/64 in (1.2 mm)	1
... 2	◆209029	.. .052 in (1.3 mm)	1
... 2	◆209030	.. 1/16 in (1.6 mm)	1

Item No.	Part No.	Description	Quantity
----------	----------	-------------	----------

Figure 9-1. Consumables Flowchart (Continued)

Table 9-5. Value Multi-Turn Contact Tips*

... 2	◆071 825	.. .030 in (0.9 mm)	1
... 2	◆054 202	.. .035 in (0.9 mm)	1
... 2	◆054 201	.. .045 in (1.2 mm)	1
... 2	◆199 593	.. .3/64 in (1.2 mm) Aluminum Wire	1
... 2	◆044 006	.. .052 in (1.3 mm)	1
... 2	◆047 566	.. 1/16 in (1.6 mm)	1
... 2	◆202 933	.. 1/16 in (1.6 mm) Aluminum Wire	1

Table 9-6. Gas Diffusers

... 3	◆198 857	.. 1/8 in Tip Recess – For Extra Heavy Duty FasTip Contact Tips	1
... 3	◆199 623	.. Flush Tip – For Extra Heavy Duty FasTip Contact Tips	1
... 3	◆199 621	.. 1/8 in Tip Recess – For Value Multi-Turn Contact Tips	1
... 3	◆199 622	.. Flush Tip – For Value Multi-Turn Contact Tips	1
... 3	227 749	.. 1/8 in Tip Recess – For Heavy Duty FasTip Contact Tips (Standard On All Guns)	1
... 3	◆231 511	.. 1/4 in Tip Recess – For Heavy Duty FasTip Contact Tips	1
... 3	◆231 512	.. Flush Tip – For Heavy Duty FasTip Contact Tips	1
... 3	◆209 031	.. Slip On Recessed Diffuser (Requires Nozzle 209033 Or 209034 And Insulator 209047, Used With Any Tapered FasTip Contact Tip)	1
... 3	◆209 032	.. Slip On Flush Diffuser (Requires Nozzle 209033 Or 209034 And Insulator 209047, Used With Any Tapered FasTip Contact Tip)	1
... 3	◆209 099	.. Spot Diffuser (Requires Spot Nozzle 176238 Or 176240 Or 176242)	1

Table 9-7. Insulators

... 4	232 284	.. Insulator, Nozzle Collared Diffuser	1
... 4	198 856	.. Insulator, Rubber	1
... 4	209 047	.. Insulator, Teflon (Required When Using Diffuser 209031 Or 209032 With Nozzle 209033 Or 209034)	1

Table 9-8. Barrel Assemblies

... 5	221 087	.. Barrel Assy, Air Cooled Pistol	1
-------	---------	-----------------------------------	---

Table 9-9. Head Tube Assemblies

.....	231 523	.. Kit, Head Tube Assy Air Cooled Pistol	1
-------	---------	--	---

◆ OPTIONAL

*All contact tips are packaged in bags of 25.

BE SURE TO PROVIDE MODEL WHEN ORDERING REPLACEMENT PARTS.

To maintain the factory original performance of your equipment, use only Manufacturer's Suggested Replacement Parts. Model is required when ordering parts from your local distributor.

TRUE BLUE[®]

WARRANTY

Effective January 1, 2009

(Equipment with a serial number preface of LK or newer)

This limited warranty supersedes all previous Miller warranties and is exclusive with no other guarantees or warranties expressed or implied.

Warranty Questions?

Call
1-800-4-A-MILLER
for your local
Miller distributor.

Your distributor also gives
you ...

Service

You always get the fast,
reliable response you
need. Most replacement
parts can be in your
hands in 24 hours.

Support

Need fast answers to the
tough welding questions?
Contact your distributor.
The expertise of the
distributor and Miller is
there to help you, every
step of the way.

LIMITED WARRANTY – Subject to the terms and conditions below, Miller Electric Mfg. Co., Appleton, Wisconsin, warrants to its original retail purchaser that new Miller equipment sold after the effective date of this limited warranty is free of defects in material and workmanship at the time it is shipped by Miller. THIS WARRANTY IS EXPRESSLY IN LIEU OF ALL OTHER WARRANTIES, EXPRESS OR IMPLIED, INCLUDING THE WARRANTIES OF MERCHANTABILITY AND FITNESS.

Within the warranty periods listed below, Miller will repair or replace any warranted parts or components that fail due to such defects in material or workmanship. Miller must be notified in writing within thirty (30) days of such defect or failure, at which time Miller will provide instructions on the warranty claim procedures to be followed.

Miller shall honor warranty claims on warranted equipment listed below in the event of such a failure within the warranty time periods. All warranty time periods start on the delivery date of the equipment to the original end-user purchaser, and not to exceed one year after the equipment is shipped to a North American distributor or eighteen months after the equipment is shipped to an International distributor.

1. 5 Years Parts — 3 Years Labor
 - * Original main power rectifiers only to include SCRs, diodes, and discrete rectifier modules
2. 3 Years — Parts and Labor
 - * Transformer/Rectifier Power Sources
 - * Plasma Arc Cutting Power Sources
 - * Process Controllers
 - * Semi-Automatic and Automatic Wire Feeders
 - * Inverter Power Sources (Unless Otherwise Stated)
 - * Water Coolant Systems (Integrated)
 - * Intellitig
 - * Engine Driven Welding Generators
(NOTE: Engines are warranted separately by the engine manufacturer.)
3. 1 Year — Parts and Labor Unless Specified
 - * Motor Driven Guns (w/exception of Spoolmate Spoolguns)
 - * Positioners and Controllers
 - * Automatic Motion Devices
 - * RFCS Foot Controls
 - * Induction Heating Power Sources, Coolers, and Electronic Controls/Recorders
 - * Water Coolant Systems (Non-Integrated)
 - * Flowgauge and Flowmeter Regulators (No Labor)
 - * HF Units
 - * Grids
 - * Spot Welders
 - * Load Banks
 - * Fume Extractors
 - * Arc Stud Power Sources & Arc Stud Guns
 - * Racks
 - * Running Gear/Trailers
 - * Plasma Cutting Torches (except APT & SAF Models)
 - * Field Options
(NOTE: Field options are covered under True Blue[®] for the remaining warranty period of the product they are installed in, or for a minimum of one year — whichever is greater.)
 - * Bernard-Branded Mig Guns (No Labor)
 - * Weldcraft-Branded TIG Torches (No Labor)
 - * Subarc Wire Drive Assemblies
4. 6 Months — Batteries
5. 90 Days — Parts
 - * MIG Guns and Subarc (SAW) Guns

- * Induction Heating Coils and Blankets, Cables, and Non-Electronic Controls
- * APT & SAF Model Plasma Cutting Torches
- * Remote Controls
- * Accessory (Kits)
- * Replacement Parts (No labor)
- * Spoolmate Spoolguns
- * Canvas Covers

Miller's True Blue[®] Limited Warranty shall not apply to:

1. **Consumable components; such as contact tips, cutting nozzles, contactors, brushes, slip rings, relays or parts that fail due to normal wear. (Exception: brushes, slip rings, and relays are covered on Bobcat, Trailblazer, and Legend models.)**
2. Items furnished by Miller, but manufactured by others, such as engines or trade accessories. These items are covered by the manufacturer's warranty, if any.
3. Equipment that has been modified by any party other than Miller, or equipment that has been improperly installed, improperly operated or misused based upon industry standards, or equipment which has not had reasonable and necessary maintenance, or equipment which has been used for operation outside of the specifications for the equipment.

MILLER PRODUCTS ARE INTENDED FOR PURCHASE AND USE BY COMMERCIAL/INDUSTRIAL USERS AND PERSONS TRAINED AND EXPERIENCED IN THE USE AND MAINTENANCE OF WELDING EQUIPMENT.

In the event of a warranty claim covered by this warranty, the exclusive remedies shall be, at Miller's option: (1) repair; or (2) replacement; or, where authorized in writing by Miller in appropriate cases, (3) the reasonable cost of repair or replacement at an authorized Miller service station; or (4) payment of or credit for the purchase price (less reasonable depreciation based upon actual use) upon return of the goods at customer's risk and expense. Miller's option of repair or replacement will be F.O.B., Factory at Appleton, Wisconsin, or F.O.B. at a Miller authorized service facility as determined by Miller. Therefore no compensation or reimbursement for transportation costs of any kind will be allowed.

TO THE EXTENT PERMITTED BY LAW, THE REMEDIES PROVIDED HEREIN ARE THE SOLE AND EXCLUSIVE REMEDIES. IN NO EVENT SHALL MILLER BE LIABLE FOR DIRECT, INDIRECT, SPECIAL, INCIDENTAL OR CONSEQUENTIAL DAMAGES (INCLUDING LOSS OF PROFIT), WHETHER BASED ON CONTRACT, TORT OR ANY OTHER LEGAL THEORY.

ANY EXPRESS WARRANTY NOT PROVIDED HEREIN AND ANY IMPLIED WARRANTY, GUARANTY OR REPRESENTATION AS TO PERFORMANCE, AND ANY REMEDY FOR BREACH OF CONTRACT TORT OR ANY OTHER LEGAL THEORY WHICH, BUT FOR THIS PROVISION, MIGHT ARISE BY IMPLICATION, OPERATION OF LAW, CUSTOM OF TRADE OR COURSE OF DEALING, INCLUDING ANY IMPLIED WARRANTY OF MERCHANTABILITY OR FITNESS FOR PARTICULAR PURPOSE, WITH RESPECT TO ANY AND ALL EQUIPMENT FURNISHED BY MILLER IS EXCLUDED AND DISCLAIMED BY MILLER.

Some states in the U.S.A. do not allow limitations of how long an implied warranty lasts, or the exclusion of incidental, indirect, special or consequential damages, so the above limitation or exclusion may not apply to you. This warranty provides specific legal rights, and other rights may be available, but may vary from state to state.

In Canada, legislation in some provinces provides for certain additional warranties or remedies other than as stated herein, and to the extent that they may not be waived, the limitations and exclusions set out above may not apply. This Limited Warranty provides specific legal rights, and other rights may be available, but may vary from province to province.





Owner's Record

Please complete and retain with your personal records.

Model Name

Serial/Style Number

Purchase Date

(Date which equipment was delivered to original customer.)

Distributor

Address

City

State

Zip



For Service

Contact a DISTRIBUTOR or SERVICE AGENCY near you.

Always provide Model Name and Serial/Style Number.

Contact your Distributor for:

Welding Supplies and Consumables

Options and Accessories

Personal Safety Equipment

Service and Repair

Replacement Parts

Training (Schools, Videos, Books)

Technical Manuals (Servicing Information and Parts)

Circuit Diagrams

Welding Process Handbooks

To locate a Distributor or Service Agency visit www.millerwelds.com or call 1-800-4-A-Miller

Contact the Delivering Carrier to:

File a claim for loss or damage during shipment.

For assistance in filing or settling claims, contact your distributor and/or equipment manufacturer's Transportation Department.

Miller Electric Mfg. Co.

An Illinois Tool Works Company
1635 West Spencer Street
Appleton, WI 54914 USA

International Headquarters—USA

USA Phone: 920-735-4505 Auto-Attended
USA & Canada FAX: 920-735-4134
International FAX: 920-735-4125

For International Locations Visit
www.MillerWelds.com

