

 **YORK**[®]
INSTALL CONFIDENCE

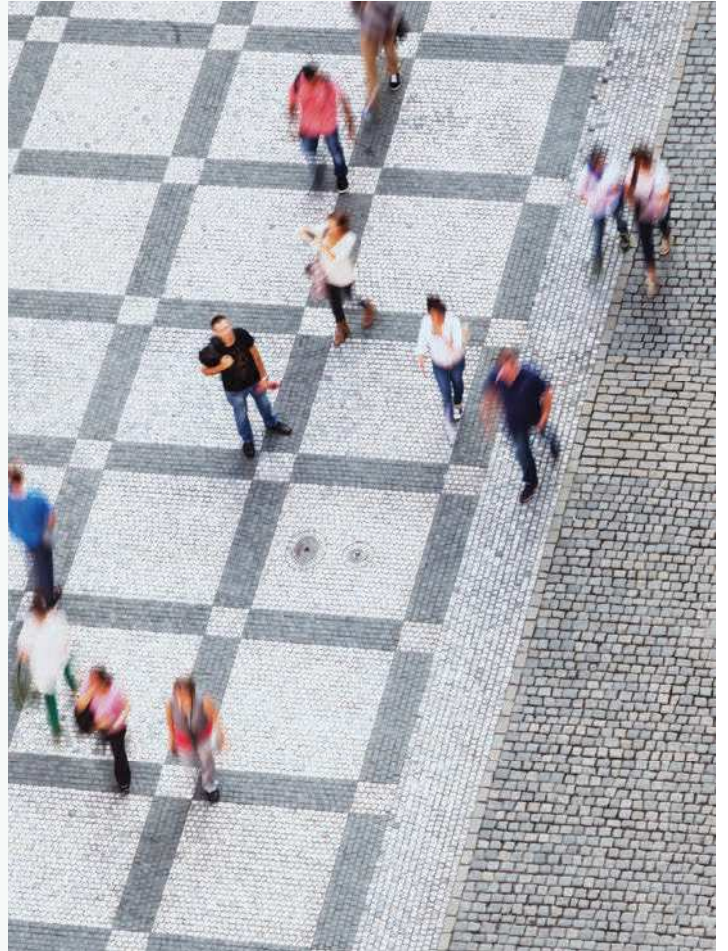

YORK[®] Commercial & Industrial HVAC 2016

A more comfortable,
safe and sustainable world

Solutions for your success

Every building is unique in design and technical requirements.

Our customers always receive customised building solutions to meet their individual needs.

Johnson Controls can handle many challenges with its innovative and flexible solutions. From A to Z, from consulting to planning, installation, maintenance (service, inspection and repair) and modernisation – Johnson Controls supports customers throughout the entire life cycle of a building.



AIR CONDITIONING SOLUTIONS

- Chillers & fan coils
- Absorption chillers
- Cooling towers
- Dry coolers
- Air Handling Units



BUILDING AUTOMATION

- Monitoring, control and optimisation
- Standardised communication protocols



SECURITY SOLUTIONS

- Identity management
- Facility zoning
- Video surveillance systems
- Alarm systems



Our well thought-out solutions guarantee a high level of comfort and energy efficiency.

The majority of our products are already rated as Class A for Energy Efficiency, with high levels of compatibility and flexibility allowing for future additions to be carried out without difficulty.

External systems can be easily integrated using BACnet® or proprietary solutions.

Our service team is available to you 24 hours a day with one of the largest service networks in Europe.



AIR CONDITIONING SOLUTIONS

- Air systems
- VRF systems
- Roof-top air-conditioners
- Minisplits



ROOM CONTROL

- Integration of HVAC controls with lighting and automatic blinds



SERVICE & SOLUTIONS

- Maintenance solutions
- Modernisation solutions
- Energy performance contract solutions
- Renewable energy solutions

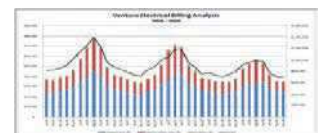

ENERGY MANAGEMENT

- Energy monitoring
- Real time consumption Mgmt
- Continuous commissioning

Reference sites

At Johnson Controls, we are dedicated to protecting the environment since our invention of the electric thermostat in 1885, which provided a fundamental shift in the energy efficiency of buildings. Now, all over the world, our products and services empower customers and communities to consume less energy and conserve resources.

The following sites represent building solutions we have developed for our customers based on wide-ranging cross industrial experience in HVAC&R equipment, controls, fire and security systems, and services for commercial and industrial buildings.



Doğanay ▶

The name Doğanay come to be known in the food sector as the synonym for quality, prioritizing the concepts of quality, service, integrity, respect and love. We as Johnson Controls proud to be a part of their production cycle by giving a superior advantage of VSD driven water cooled and air cooled chillers.



OBA Makarna ▶

OBA Makarna, which was established in the year 1966 in Gaziantep, makes world class production in its new and modern facilities together with our YCIV & YVAA series air-cooled screw chillers which provides superior control and industry leading efficiency, delivering lower equipment and installation costs and driving down the total cost of ownership.



Naksan Plastik ▶

Naksan Plastik, which always aims for the best quality and researches the development in the sector systematically bringing all the innovation to its customers, is a global brand with its exports to 140 countries and they are strengthening awareness for the environment with environmentally friendly productions as well.



◀ Zorlu Center

Zorlu Center is one of the most prestigious and the first mixed-use project in Turkey. Our centrifugal chillers, air handling units, chiller plant optimization systems (CPO) and operation & maintenance services are provided as a single source solution partner.

Catalogue content

Page

Chillers & Heat Pumps

ECOFRIO v2 / ECOFRIO v2 Plus Air cooled chiller / heat pump	12
ECOFRIO v2 Air cooled chiller / heat pump	16
YLCD-YLHD Air cooled chiller / heat pump	20
YCAE Modular air cooled scroll chiller / heat pump NEW	24
YLAA Air-cooled scroll compressor chiller	26
YLRA Air cooled heat pump scroll compressor	30
YVAA Air-cooled VSD screw chiller	34
YMWA / YMRA Water-cooled cooling only, remote condenser and heat pump scroll compressor chiller	38
YCSE / YCRE Style C Water-cooled or remote air-cooled screw compressor chiller NEW	40
YCWL / YCRL Water-cooled or remote air-cooled scroll compressor chiller	42
YLCS Water-cooled or remote air-cooled screw compressor chiller	48
YVWA Water-cooled variable speed screw chiller	54
YMC ² Water-cooled magnetic centrifugal chiller	58
YK Water-cooled centrifugal chiller	60
YHAU CL Single stage hot water driven absorption chiller NEW	62
YORK® Absorption chillers and heat pumps NEW	64
WFC SC Single stage hot water absorption chiller / CH K & CH MG Natural gas-fired chiller/heaters	66
Central Plant Optimization™ 10	68
Heat Pumps solutions	70

Air Handling Systems & Terminal Devices

YMA Custom air handling units	78
YFCN Fan Coil Unit centrifugal fan	82
YFCN-ECM Fan Coil Unit Inverter with centrifugal fan	84
LASER & LOW BODY Fan Coil Units	92
LASER ECM & LOW BODY ECM Fan Coil Units	100
YEFB Hydro Blower	102
YGFC Fan Coil Unit	104
YHK Hydro Cassette	106
YHK ECM Inverter Hydro Cassette	108
YFCC Coanda Hydro Cassette	112
YFCC-ECM Coanda Hydro Cassette Inverter	114
YHVP & YHVP-ECM Hydro High Wall	118
YORK® YC-P Series Close Control Air Conditioners	124
YORK® YC-G Series Close Control Air Conditioners	132
YORK® YC-R Series Close Control Air Conditioners	134
SmartPac - Factory Packaged Control	136

Packaged Equipment & Large Split Systems

Roomtop RTC-RTH - L	144
ACTIVA Rooftop ARC-ARG-ARH-ARD 017 to 040 AB	146
ACTIVA Rooftop ARC-ARG-ARH-ARD 045 to 090 AB	150
Large ACTIVA Rooftop ARC-ARG-ARH-ARD 100 to 180 AB	156
VITALITY Axial Fan Large Split VAC/VAH - VIR 20 to 90 AB	162
VITALITY Centrifugal Large Split VCH-VIR 20 to 90 AB	168

Comprehensive Solutions

Industrial Refrigeration	178
Metasys® Building Automation and Control Systems	186
Metasys® Energy Dashboard	188



Chillers & Heat Pumps

SCROLL COMPRESSOR CHILLERS
AND HEAT PUMPS

SCREW COMPRESSOR CHILLERS
AIR-COOLED & WATER-COOLED

CENTRIFUGAL COMPRESSOR CHILLERS
WATER-COOLED

ABSORPTION CHILLERS AND HEAT PUMPS

CENTRAL PLANT OPTIMISATION™ 10

ECOFRIO v2 / ECOFRIO v2 Plus Air cooled chiller / heat pump

YLCA 0012 to 0027 / YLHA 0012 to 0027 Plus

A complete range from 12 kW up to 25.8 kW



The **YORK YLCA/YLHA** air-cooled chillers and heat pumps represents the right solution for any kind of installation.

With thousand. of units installed all around Europe and Africa, used for different applications and in different climate conditions are one of the most flexible and reliable scroll type chillers in the market.

The standard product configuration and the different options and accessories selectable by the customer make these units ideal where a compact, and high performance unit is required.

Features

- Scroll compressor units
- Very compact units
- High efficiency units
- Leaving and return water temperature control
- Hydro pack standard
- Buffer tank supresion function
- Dynamic set point function
- Fan speed control as standard
- Coated condenser fins as standard (blue fin)
- Flow switch and water filter included

Options / Accessories

- Condenser copper fins
- BMS Communication (Carel and Modbus protocol)
- Remote control / Remote terminal
- High pressure fans
- External buffer tank
- Tray cable heater (YLHA Plus)
- Condenser protection grill

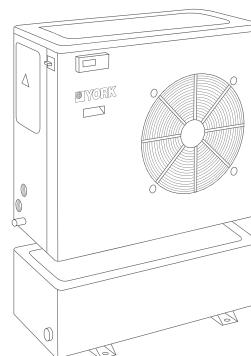

External Buffer tank in accessories



ECOFRIO v2 / ECOFRIO v2 Plus

YLCA 0012 to 0027 / YLHA 0012 to 0027 Plus

Technical features

T Three phases supply C Hydro Pack

Model	YLCA G1				YLHA PLUS G1				
	0012 TC	0015 TC	0020 TC	0027 TC	0012 TC	0015 TC	0020 TC	0027 TC	
Performance	Cooling capacity (1)	12.6	14.8	19.9	26.2	12.2	14.1	19.8	26.4
	Total Input Power (1)	4.32	5.9	6.96	9.26	4.31	5.62	7.07	9.07
	EER (1)	2.92	2.51	2.86	2.83	2.83	2.51	2.8	2.91
	ESEER	3.07	2.87	3.66	3.07	3.05	2.77	3.27	3.24
	Heating capacity (1)	-	-	-	-	12.2	15.8	19.8	25.7
	Total Input Power (1)	-	-	-	-	4.31	5.32	6.64	8.77
	COP (1)	-	-	-	-	2.83	2.97	2.98	2.93
	Heating capacity (2)	-	-	-	-	12.6	16.4	20.5	26.8
	COP (2)	-	-	-	-	3.86	4.0	3.79	3.8
	Capacity steps	0 / 100							
	Sound power level	73	73	74	78	73	73	74	78
	Sound pressure level at 10 m	43	43	44	48	43	43	44	48
	Compressor	Type	Scroll						
Quantity		1							
Air side heat exchanger	Fans quantity	2							
	Working ambient temp. cool / heat mode	(5) (-18°C) -10°C ~ 46°C		-18°C ~ 46°C		-18°C ~ 46°C / -15°C ~ 20°C			
Water side heat exchanger	Type	Plate Heat Exchanger							
	Unit water volume	1.5	2	2.8	3.2	1.5	2	2.8	3.2
	Pump Type	Multi stage							
	Nominal water flow in cooling	2 065	2 530	3 360	4 405	1 980	2 375	3 335	4 440
	Available pressure (1) (3)	115	152	134	191	118	160	130	191
	Working water leaving temp. cooling/heating mode (4)	-5°C to 15°C / 30°C to 50°C							
	Water connections	1"	1 1/4"		1"		1 1/4"		
Dimensions & Weight	Height / Width / Depth	1 270 / 905 / 460		1270/1430/502		1 270 / 905 / 460		1270/1430/502	
	Weight	146	160	220	290	150	164	235	330
Electrical features	Voltage / Phases / Frequency	400-3-50+N+E							
	Maximum Unit current	11.6	15.8	18.1	23	11.6	12.4	15.5	21

(1) net values at Nominal conditions (2) net values at floor heating conditions (3) with filter (4) below 6°C with glycol (5) -18°C with LAK option

Nominal conditions: Cooling capacities for 7°C water leaving temperature Δt 5°C and 35°C ambient temperature

Heating capacities for 45°C water leaving temperature Δt 5°C and 7°C ambient temperature

Floor heating conditions: Heating capacities for 35°C water leaving temperature Δt 5°C and 7°C ambient temperature

Compatibility table / Codes

YLCA Model	0012 TC	0015 TC	0020 TC	0027 TC
Cooling only units (Pack included)	S668551282	S668551582	S668552082	S668552782
YLHA Plus Model	0012 TC	0015 TC	0020 TC	0027 TC
Heat pump units (Pack included)	S668651285	S668651585	S668652085	S668652785

Use this unit code when a factory fitted option is NOT required

Accessories (Supplied loose)

Water tank	30 Liters	S613990300	-	S613990300	-
	115 Liters	-	S613991150	-	S613991150
Water tank + heater	30 L + 4.5 kW (3~)	-	-	S613990305	-
	30 L + 6 kW (3~)	-	-	S613990306	-
	115 L + 10.5 kW (3~)	-	-	-	S613991151
Remote control					S613802011
Remote terminal					S613802231
BMS Communication					S613802041
Anti vibration mounting	S613029001	S613029002		S613029001	S613029002
Compressor heater	S613760322	STANDARD		S613760322	STANDARD
Tray cable heater					S611080788

YLCA Model	0012 TC	0015 TC	0020 TC	0027 TC
Cooling only units (Pack included)	S668000010	S668000012	S668000014	S668000016
YLHA Plus Model	0012 TC	0015 TC	0020 TC	0027 TC
Heat pump units (Pack included)	S668000239	S668000242	S668000243	S668000244

Use this unit code when a factory fitted option is required

Options (Factory fitted)

High pressure fans	S611991083		S611991085	S611991083		S611991085
Condenser protection grill	S613995085	S613995086	S613995087	S613995085	S613995086	S613995087
LAK -18°C	S613112083		STANDARD			



Manufacturer reserves the rights to change specifications without prior notice.

Dimensions, hydraulic connections and space requirements

YLCA-YLHA PLUS 0012/0015 TC

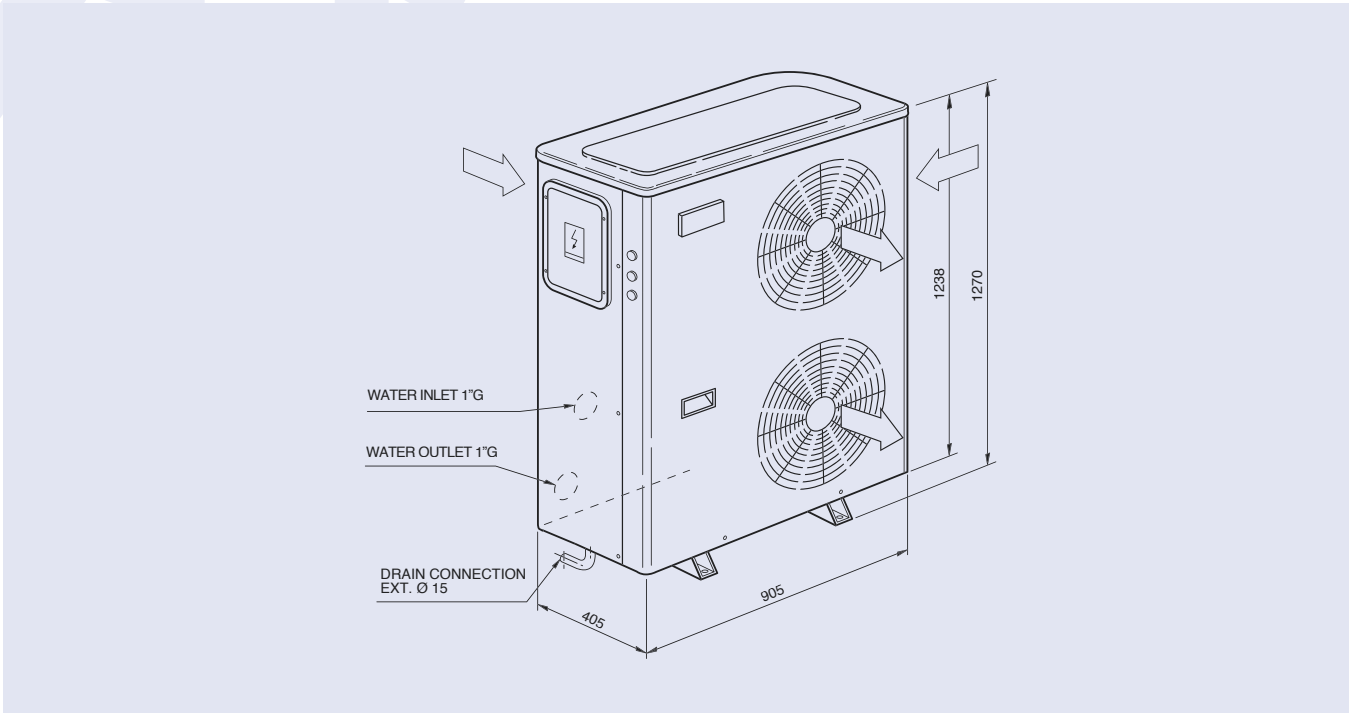

All dimensions in mm. Drawings not a scale.

YLCA-YLHA PLUS 0020/0027 TC

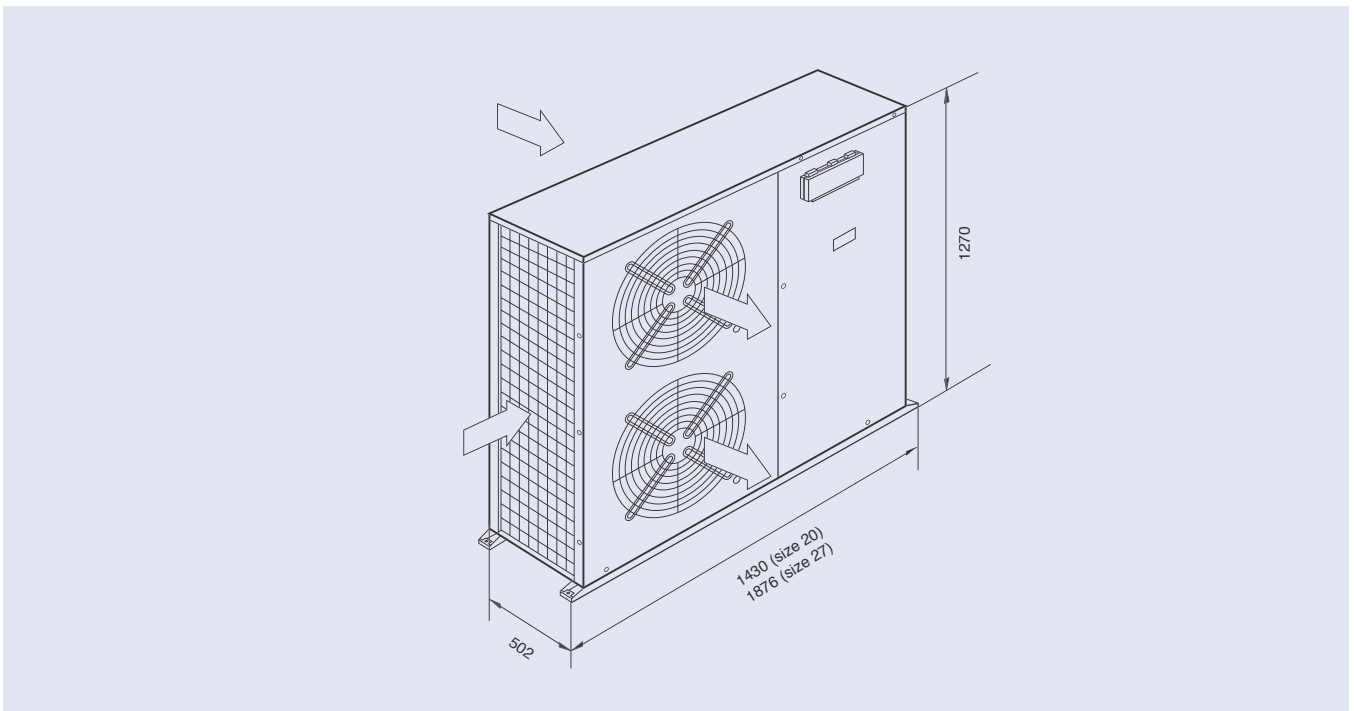

All dimensions in mm. Drawings not a scale.



YLCA-YLHA PLUS 0012 to 0027

Models YLCA-YLHA PLUS 0012/0015

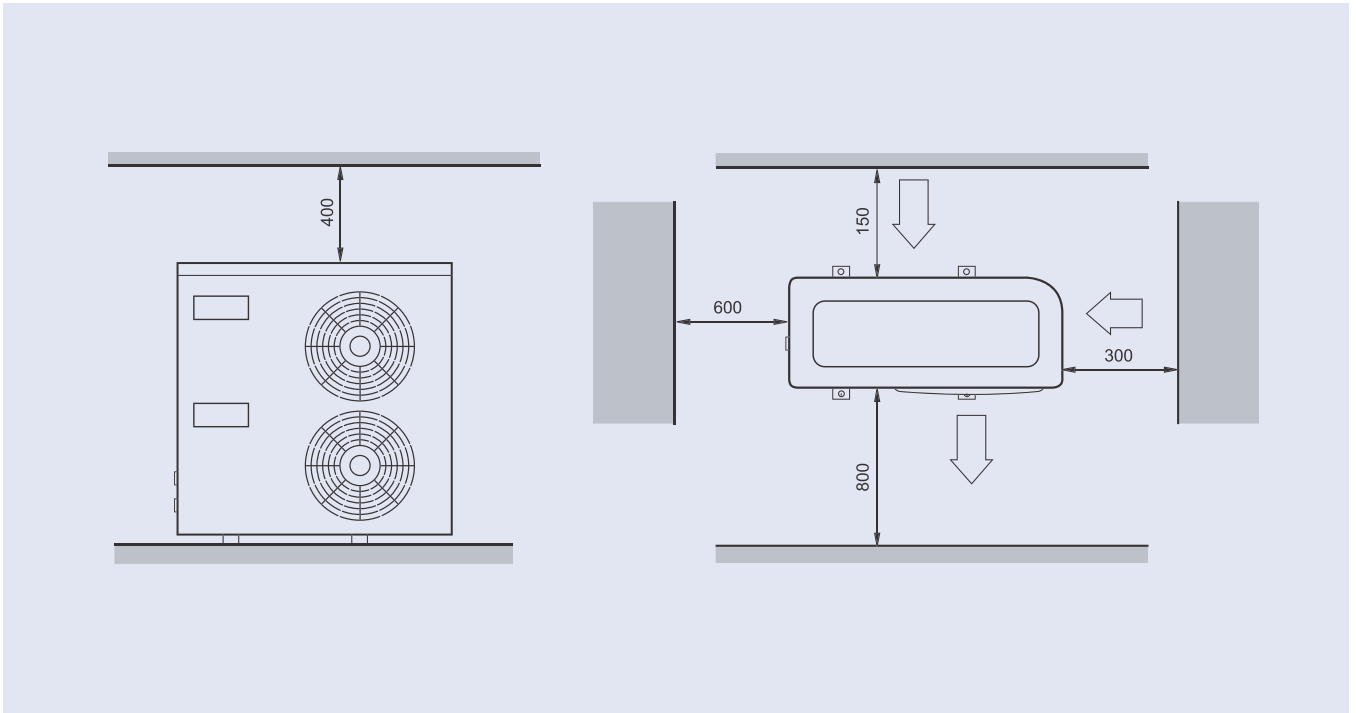

All dimensions in mm. Drawings not a scale.

Models YLCA-YLHA PLUS 0020/0027

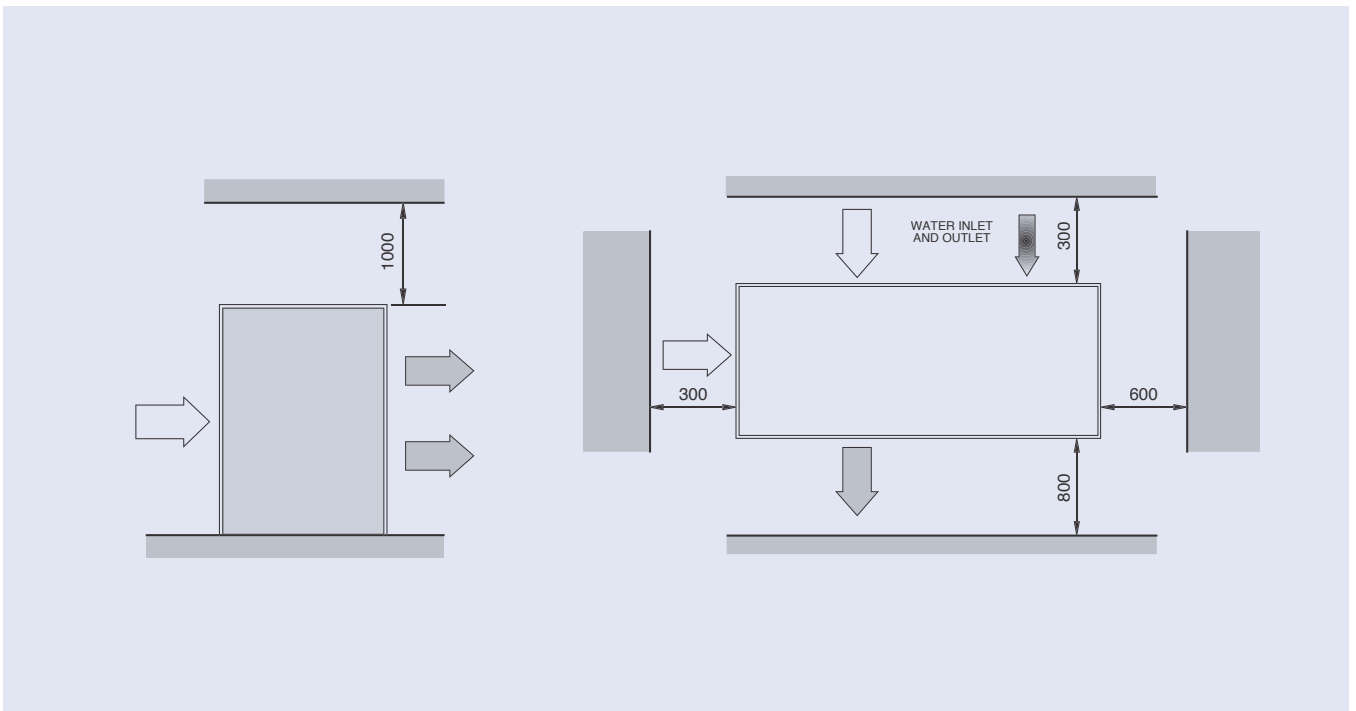

All dimensions in mm. Drawings not a scale.

ECOFRIO v2

Air cooled chiller / heat pump

YLCA / YLHA 0040 to 0150

A complete range from 39.6 kW up to 151 kW



The **YORK YLCA/YLHA** air-cooled chillers and heat pumps represents the right solution for any kind of installation.

With thousands of units installed all around Europe and Africa, used for different applications and in different climate conditions are one of the most flexible and reliable scroll type chillers in the market.

The standard product configuration and the different options and accessories selectable by the customer make these units ideal where a compact, and high performance unit is required.

Features

YLCA/YLHA 0040 to 0080

- 2 capacity steps (1 for size 40)
- LWT & RWT Control
- Plate heat exchanger
- Condenser fins (blue fin)
- Pressostatic LAK (-18°C)

YLCA/YLHA 0100 to 0150

- Same features as YLCA/YLHA 40 to 80
- 4 capacity steps
- High efficiency at full and partial load
- Reduced noise levels
- 1/4 turn lock for easy access

Options / Accessories

- Unit without pack
- BMS Communication (Carel and Modbus protocol)
- Remote control
- Remote terminal
- Water filter (unit without Hydro Pack)
- Flow switch (unit without Hydro Pack)
- Low noise version
- Dual pump version
- Antivibration mountings
- Condenser protection grille



Low noise version with special insulation in the compressor chamber.

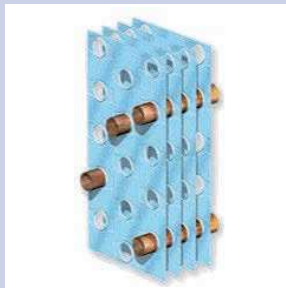

Special coating on the condenser fins for improved corrosion protection.

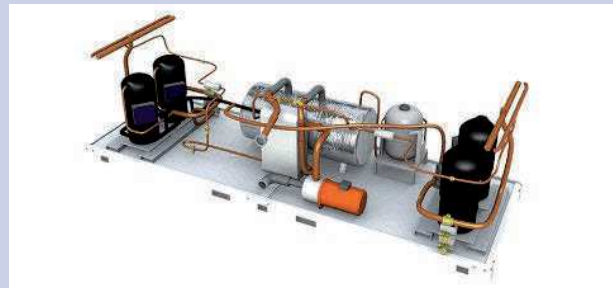

Pump built-in for space saving and easy installation.



ECOFRIO v2

YLCA / YLHA 0040 to 0150

Technical features

T Three phases supply P Hydro Pack H Heat pump

Model		YLCA / YLHA								
		0040 T-TP	0050 T-TP	0060 T-TP	0080 T-TP	0100 T-TP	0120 T-TP	0150 T-TP		
Performance	Cooling capacity c/o units (1)	kW		39.3	51.8	60.1	77	100.3	118.5	150.5
	Total Input Power (1) (3)	kW		13.69	18.3	20.03	27.11	34.47	40.44	54.14
	EER (1)			2.87	2.83	3	2.84	2.91	2.93	2.78
	ESEER (1)			3.15	3.18	3.3	3.15	3.74	3.83	3.66
	Cooling capacity h/p units (1)	kW		37.6	51.2	60.1	71.7	95.4	113.6	144.5
	Heating capacity h/p units (1)	kW		38.8	52.8	60	75.2	104.6	120	150.5
	Total Input Power cool/heat mode (1) kW			13.48 / 12.81	17.65 / 18.21	20.03 / 20.2	26.46 / 26.86	36.14 / 37.76	43.69 / 40	51.06 / 53.94
	EER / COP (1)			2.79 / 3.03	2.93 / 2.9	3 / 2.97	2.71 / 2.8	2.64 / 2.77	2.6 / 3	2.83 / 2.79
	ESEER (1)			3.15	3.18	3.29	2.91	3.39	3.43	3.73
	Capacity steps	%		0 / 100	0-50-100			0-25-50-75-100		
Sound power level STD / LN	dB(A)		78 / 73	81 / 76	87 / 77	83 / 79	82 / 78	82 / 78	84 / 80	
Compressor	Type	Scroll								
	Quantity	1		2			3		4	
Air side heat exchanger	Fans quantity	2		3			4			
	Working ambient temp. cool. / heat. mode	-18°C ~ 46°C / -10°C ~ 20°C								
Water side heat exchanger	Type	Single Plate Heat Exchanger				Dual Plate Heat Exchanger				
	Unit water volume (2)	Litres		131	188	194	285	193	195	214
	Pump Type	Multistage horizontal pumps								
	Nominal water flow	l/h		6 820	8 960	10 400	13 350	17 600	20 470	25 970
	Available pressure (1) (2)	kPa		105	108	158	123	187	202	186
	Pressure drop (1) (3)	kPa		75	39	50	63	59	33	27
	Working range water leaving temperature cooling / heating (4)	-5°C ~ 15°C / 30°C ~ 50°C								
Dimensions & Weight	Water connections (2)	inch		1 1/4"	2"			2 1/2"		
	Height / Width / Depth	mm		1573/1500/822	1600 / 1011 / 2104		1600/1118/2944	2190 / 1101 / 3416		2263/1101/3770
	Weight without pack / pack c/o	kg		340 / 380	524 / 580	555 / 611	715 / 785	1 124 / 1 220	1 190 / 1 286	1 415 / 1 503
	Weight without pack / pack h/p	kg		337 / 397	537 / 593	568 / 624	735 / 805	1 154 / 1 250	1 220 / 1 316	1 445 / 1 703
Electrical features	Voltage / Phases / Frequency	V/ph/hz		400 / 3 / 50+N+E						
	Maximum Unit current	A		33	46.2	49.2	70.5	80	108	120

YLCA: Cooling only units models. YLHA: Air to water heat pump models.

(1) net values at Eurovent nominal conditions (2) version P with hydro kit with filter (3) version without hydro kit (4) below 6°C with glycol

Nominal conditions: Cooling capacities in kW given for 7°C water leaving temperature Δt 5°C and 35°C ambient temperature

Heating capacities in kW given for 45°C water leaving temperature and 7°C ambient temperature

Compatibility table / Codes

Model	0040 TP	0050 TP	0060 TP	0080 TP	0100 TP	0120 TP	0150 TP
YLCA Cooling only unit (Pack included)	S668554084	S668525182	S668526182	S668528182	S668521182	S66851156	S668551507
YLHA Heat pump unit (Pack included)	S668654084	S668625182	S668626182	S668628182	S668621182	S668651156	S668651506
Model	0040 T	0050 T	0060 T	0080 T	0100 T	0120 T	0150 T
YLCA Cooling only unit (without Pack)	S668554080	S668525180	S668526180	S668528180	S668521180	S66851154	S668551503
YLHA Heat pump unit (without Pack)	S668654080	S668625180	S668626180	S668628180	S668621180	S668651154	S668651504

Use this unit code when a factory fitted option is NOT required

Accessories (Supplied loose)

AVM mounting	S613029002	S613026080	S613028180	S613021580
Mechanical flow switch	S611992021			
Water Filter *	S611300150	S611300170	S611300190	
Remote control	S613802011			
Remote terminal	S613802231			-
Cable for remote connection of the terminal	-			S613802241
B.M.S. Communication	S613802041			S613802051

Model	0040 TP	0050 TP	0060 TP	0080 TP	0100 TP	0120 TP	0150 TP
YLCA Cooling only unit (Pack included)	S668000226	S668000247	S668000251	S668000255	S668000259	S668000107	S668000111
YLHA Heat pump unit (Pack included)	S668000228	S668000248	S668000252	S668000256	S668000260	S668000131	S668000135
Model	0040 T	0050 T	0060 T	0080 T	0100 T	0120 T	0150 T
YLCA Cooling only unit (without Pack)	S668000038	S668000245	S668000249	S668000253	S668000257	S668000105	S668000109
YLHA Heat pump unit (without Pack)	S668000039	S668000246	S668000250	S668000254	S668000258	S668000129	S668000133

Use this unit code when a factory fitted option is required

Options (Factory fitted)

Low Noise version	S613990550	S613990650	S613990850	S613991050	S613991285	S613991584
Softstart	S606744692	S606744693	S606744694			
Dual pumps **	-	S613990540	S613990640	S613990840	S613991040	S613991286
Condenser protection grille	S613995090	S613995091	S613995092	S613995093		S613995094

* included with unit version "P" only for unit without pack. Filter size: 2" for YLCA 40-50-60-80 and 2 1/2" for YLHA 100-120-150.

** Dual pump option has to be ordered with units with hydrokit.



Manufacturer reserves the rights to change specifications without prior notice.

Dimensions and hydraulic connections

YLCA-YLHA 0040 T-TP

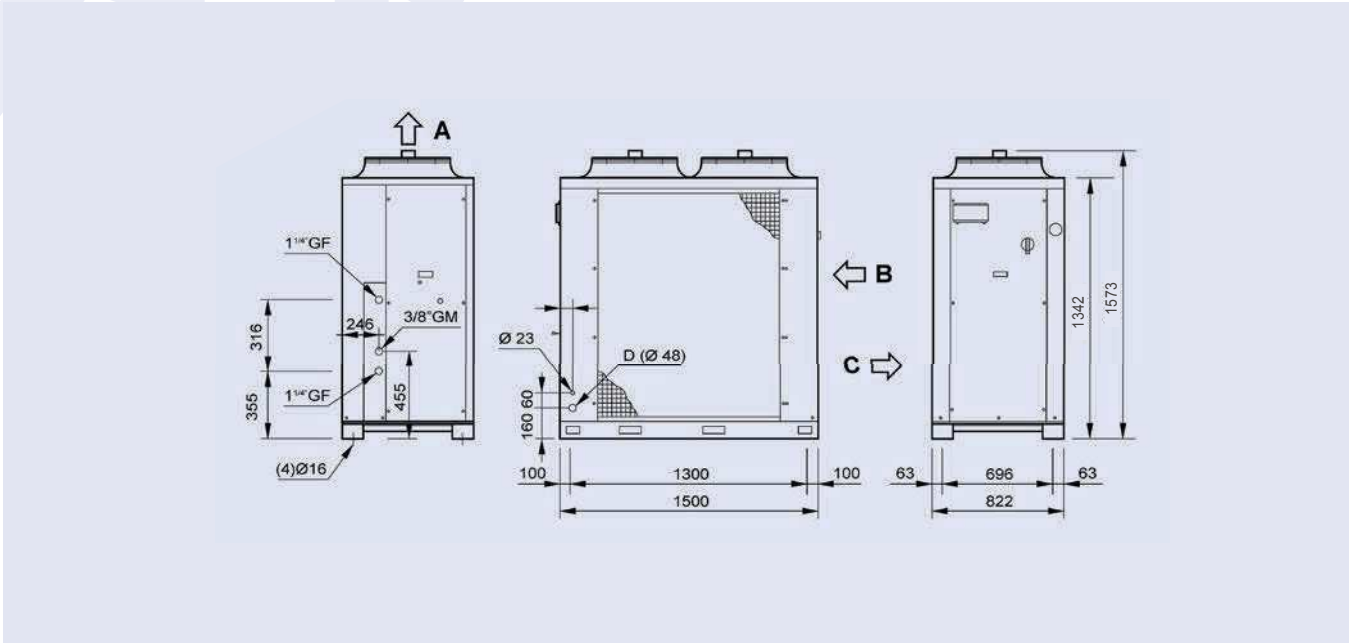

All dimensions in mm. Drawings not a scale.

Unit	A	B	C
YLCA/YLHA 0040	Air outlet	Water inlet	Water outlet

YLCA-YLHA 0050 and 0060 T-TP

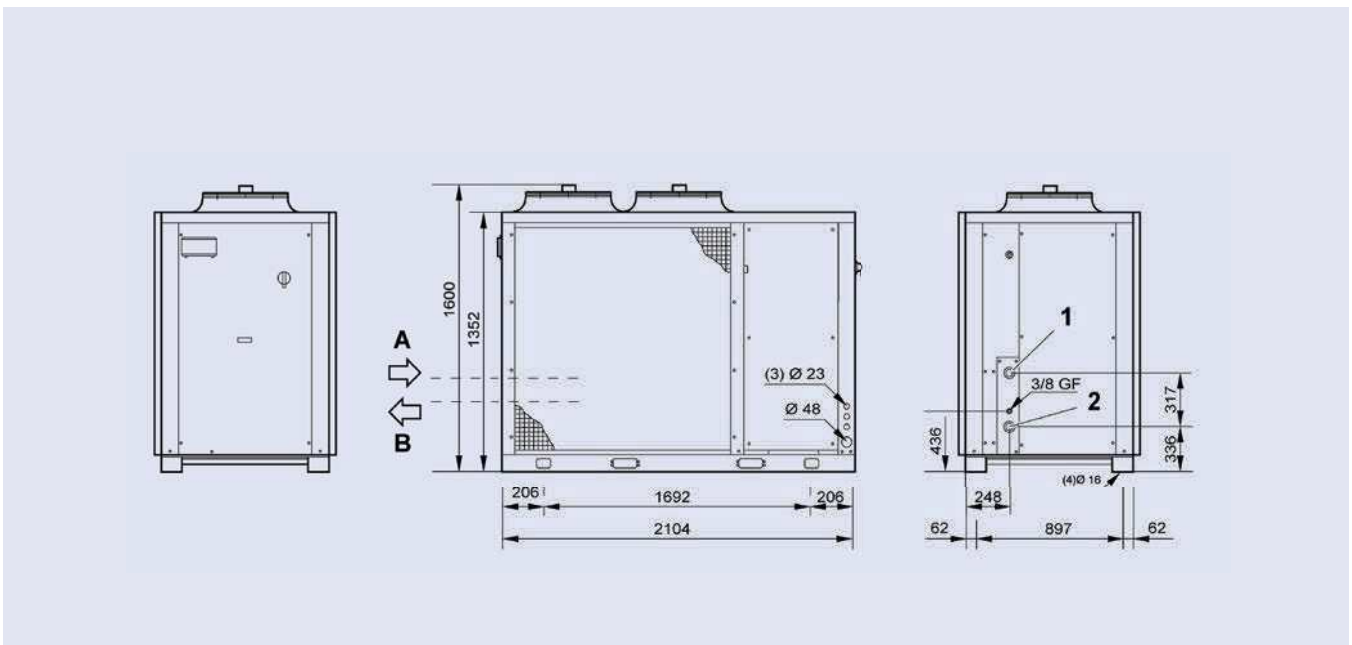

All dimensions in mm. Drawings not a scale.

Unit	A	B	1	2
YLCA/YLHA 0050-0060	Water inlet	Water outlet	2" GF (Inlet)	2" GF (Outlet)

YLCA / YLHA 0040 to 0150



YLCA-YLHA 0080 T-TP

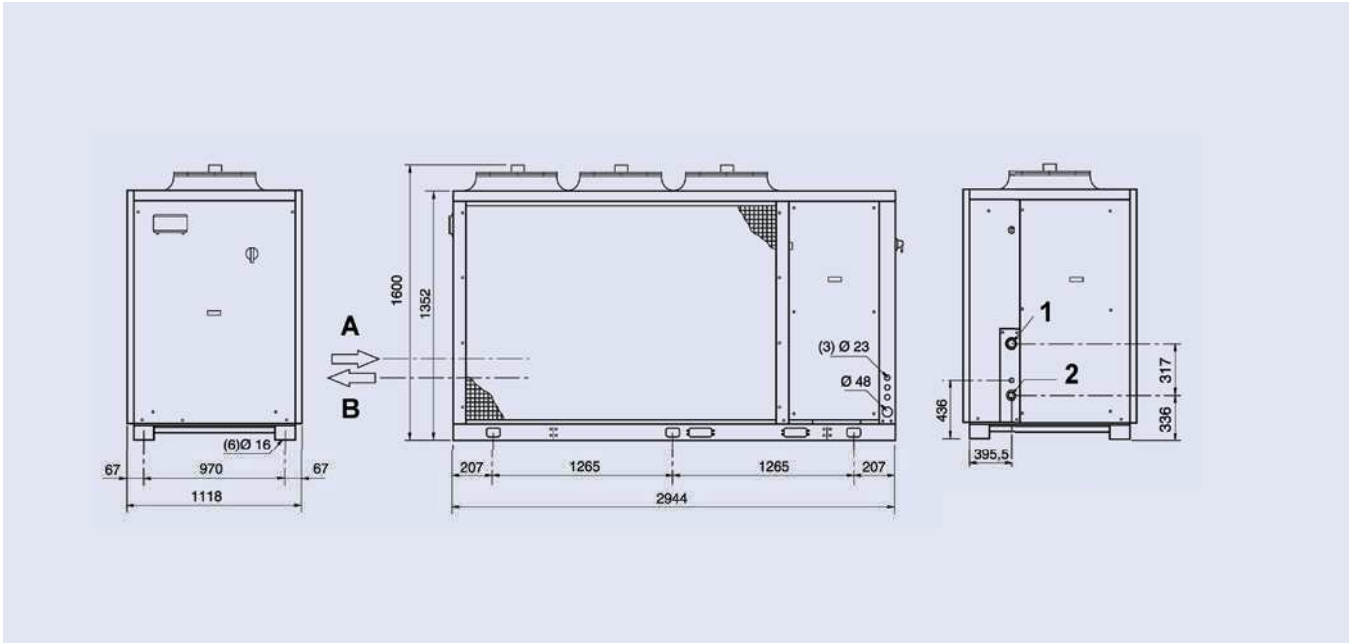

All dimensions in mm. Drawings not a scale.

Unit	A	B	1	2
YLCA/YLHA 0080	Water inlet	Water outlet	2" GF (Inlet)	2" GF (Outlet)

YLCA-YLHA 0100, 0120 and 0150 T-TP

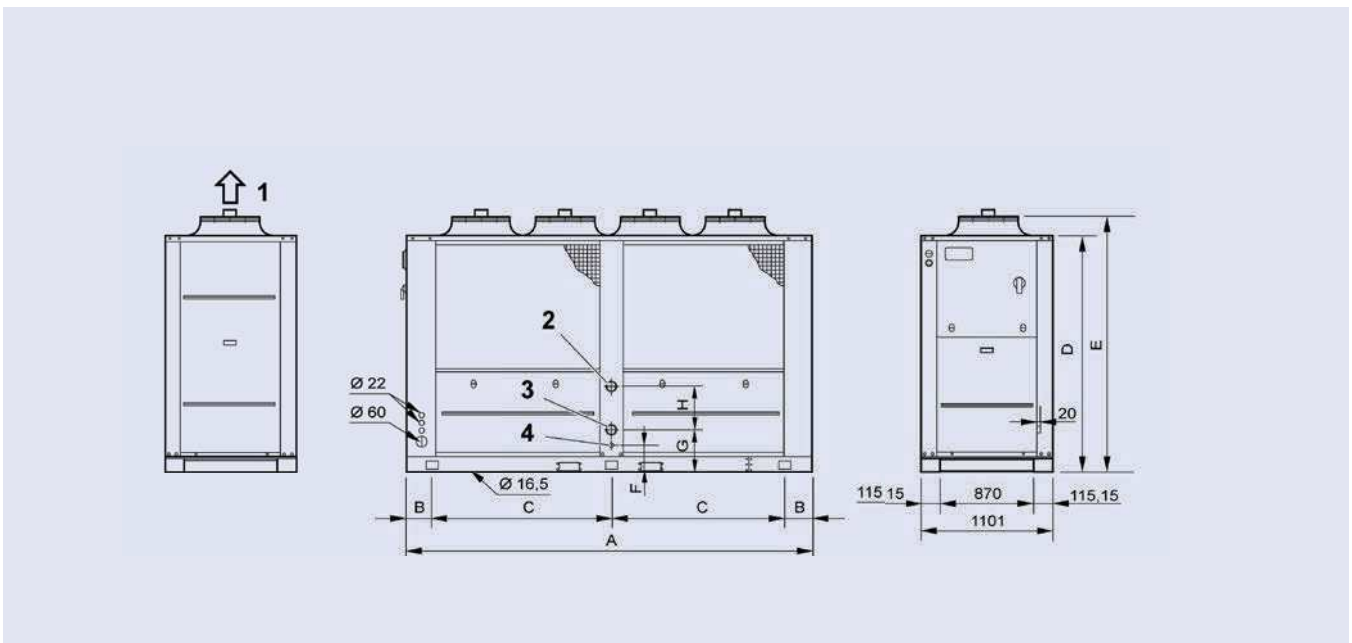

Unit	1	2	3	4	A	B	C	D	E	F	G
YLCA/YLHA 0100-0120	Air outlet	Water outlet Ø2 1/2" G	Water inlet Ø2 1/2" G	Drain Ø 20 x 20	3 416	182	1 525	1 942	2 190	199	289
YLCA/YLHA 0150					3 770	255	1 630	1 993	2 263	145	211

All dimensions in mm. Drawings not a scale.

YLCD-YLHD

Air cooled chiller / heat pump

YLCD-YLHD 0025 to 0150

A complete range from 24 kW up to 145 kW



The new **YORK YLCD/YLHD** air-cooled chillers and heat pumps with powered fans are ideal solution for units to be installed in technical rooms or in louvered/hidden spaces on the roof.

Sharing the reliable and proven designed with YLCA/YLHA, these new units using R-410a aims to help the installer and the user to help to find solutions for special and difficult installations.

The bigger sizes (from 100 to 150 kW) utilize new EC Inverter radial fans, that will keep always the right performance for the unit at any outdoor condition.

Features

- Centrifugal or radial fans
- Scroll compressor
- Vertical and horizontal discharge
- Integrated Hydro kit (P versions)
- LAK (-18°C) standard (sizes 100-150)
- Flow switch standard

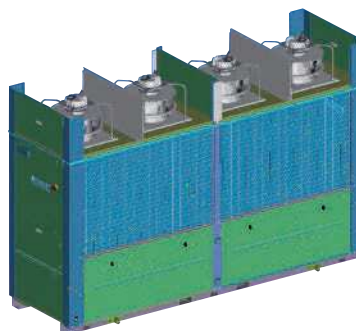

EC Radial Fans (sizes 100 to 150), using new high efficiency ventilation technology to improve the overall performance.

Options / Accessories

- Vertical Discharge kit (sizes 25 to 70)
- Low Noise (sizes 100 to 150)
- Dual Water Pumps (sizes 100 to 150)
- Water filter and water flow switch
- Antivibration mounting
- Remote control and remote terminal
- BMS communication (Carel and Modbus protocol)

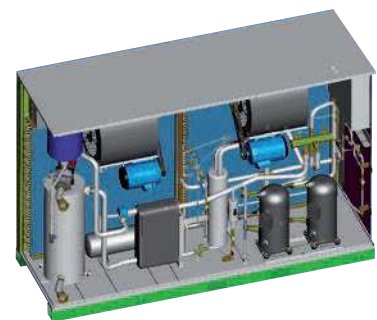

Integrated Hydrokit, shared with YLCA/YLHA product platform, for a compact and quick installation.



Air cooled chiller & heat pump

YLCD-YLHD 0025 to 0150

Technical features

T Three phases supply C/P Hydro Pack H Heat pump

Models	YLCD / YLHD								
	0025 TC	0040 T-TP	0070 T-TP	0100 T-TP	0120 T-TP	0150 T-TP			
Performance	Cooling capacity c/o units (1)	kW	24.6	39.8	69.5	98.4	118.5	144.5	
	Total Input Power (1)	kW	8.45	15.13	27.36	37.41	44.72	56.67	
	EER (1)		2.91	2.63	2.54	2.63	2.65	2.55	
	Cooling capacity h/p units (1)	kW	23.6	39.8	67.5	95.4	116.5	142.5	
	Heating capacity h/p units (1)	kW	23.4	43.2	72.5	104.6	120.1	159.5	
	Total Input Power cool/heat mode (1)	kW	8.14 / 8.18	15.13 / 15.6	26.57 / 26.46	36.27 / 37.63	42.21 / 43.2	60.13 / 59.07	
	EER / COP (1)		2.9 / 2.86	2.63 / 2.77	2.54 / 2.74	2.63 / 2.78	2.76 / 2.78	2.37 / 2.7	
	Capacity steps	%	100	50-100		25-50-75-100			
	Sound power level	dB(A)	81	83	86	86	86	87	
	Compressor	Type	Scroll						
Quantity		1	2	2	4	4	4		
Air side heat exchanger	Fans quantity	1	2	2	4	4	4		
	Nominal air flow	m³/h	8 100	18 000	23 000	36 000	48 000		
	Nominal static pressure	Pa	100		150	200			
	Working ambient temp. cool. / heat. mode		(4) (-18°C) ~ 46°C / -10°C ~ 20°C			-18°C ~ 46°C / -10°C ~ 20°C			
Water side heat exchanger	Type	Single plate heat exchanger			Dual plate heat exchanger				
	Unit water volume	Litres	32	84	92	193	195	214	
	Pump Type	Multistage horizontal pump							
	Nominal water flow	l/h	4 300	6 880	12 040	17 030	20 470	24 940	
	Available pressure (1) (2)	kPa	208	105	120	187	202	186	
	Pressure drop (1) (3)	kPa	-	31	53	54	32	24.5	
	Working range water leaving temperature cooling / heating (5)		-5°C ~ 15°C / 30°C ~ 50°C						
	Water connections	inch	1-1/4"	2"		2-1/2"			
Dimensions & Weight	Height	mm	1 526	1 794	1 794	2 460	2 460	2 480	
	Width	mm	1 740	2 659	2 659	3 466	3 416	3 768	
	Depth	mm	785	897	897	1 101	1 101	1 101	
	Weight without pack / pack c/o	kg	- / 390	730 / 770	740 / 780	1 264 / 1 360	1 264 / 1 360	1 680 / 1 776	
	Weight without pack / pack h/p	kg	- / 400	750 / 790	760 / 800	1 284 / 1 380	1 284 / 1 380	1 700 / 1 796	
El. supply	Voltage / Phases / Frequency	V/ph/hz	400 / 3 / 50 + N + E						

YLCD: Cooling only units models. YLHD: Air to water heat pump models.

(1) net values at Eurovent nominal conditions (2) version P with hydro kit with filter (3) version without hydro kit (4) -18°C with LAK option (5) below 6°C with glycol

Nominal conditions: Cooling capacities in kW given for 7°C water leaving temperature Δt 5°C and 35°C ambient temperature

Heating capacities in kW given for 45°C water leaving temperature and 7°C ambient temperature

Compatibility table / Codes

Models	-	0040 T	0070 T	0100 T	0120 T	0150 T
Cooling only unit YLCD	-	S668594083	S668597083	S668591083	S668591283	S668591583
Heat pump unit YLHD	-	S668574083	S668577083	S668571083	S668571283	S668571583
Models	0025 TC	0040 TP	0070 TP	0100 TP	0120 TP	0150 TP
Cooling only unit YLCD	S668592580	S668594080	S668597080	S668591080	S668591280	S668591580
Heat pump unit YLHD	S668572580	S668574080	S668577080	S668571080	S668571280	S668571580

Use this unit code when a factory fitted option is NOT required

Accessories (Supplied loose)

AVM mounting	S613029002	S613028180	S613021580
Flow switch	S611992021		
Remote control	S613802011		
Remote terminal	S613802231	-	
Cable for remote connection of the terminal	-	S613802241	
B.M.S. Communication	S613802041	S613802051	

Models	-	0040 T	0070 T	0100 T	0120 T	0150 T
Cooling only unit YLCD	-	S668000264	S668000268	S668000272	S668000276	S668000280
Heat pump unit YLHD	-	S668000266	S668000270	S668000274	S668000278	S668000282
Models	0025 TC	0040 TP	0070 TP	0100 TP	0120 TP	0150 TP
Cooling only unit YLCD	S668000262	S668000265	S668000269	S668000273	S668000277	S668000281
Heat pump unit YLHD	S668000263	S668000267	S668000271	S668000275	S668000279	S668000283

Use this unit code when a factory fitted option is required

Options (Factory fitted)

Low noise	NA	S613990550	NA	S613991050	S613991285	S613991584
Dual pump	NA	NA	NA	S613991040	S613991286	S613991585
Coil guard net	Standard			S613995093		S613995094
Low Ambient Kit	S613114085	S613111084		Standard		
Soft start	S606744692	S606744693		S606744694		
Vertical air discharge	S612828405	S612828205		Standard		
Copper/copper condenser	Contact Johnson Controls					



Manufacturer reserves the rights to change specifications without prior notice.

Dimensions and hydraulic connections

YLCD / YLHD 0025 TC

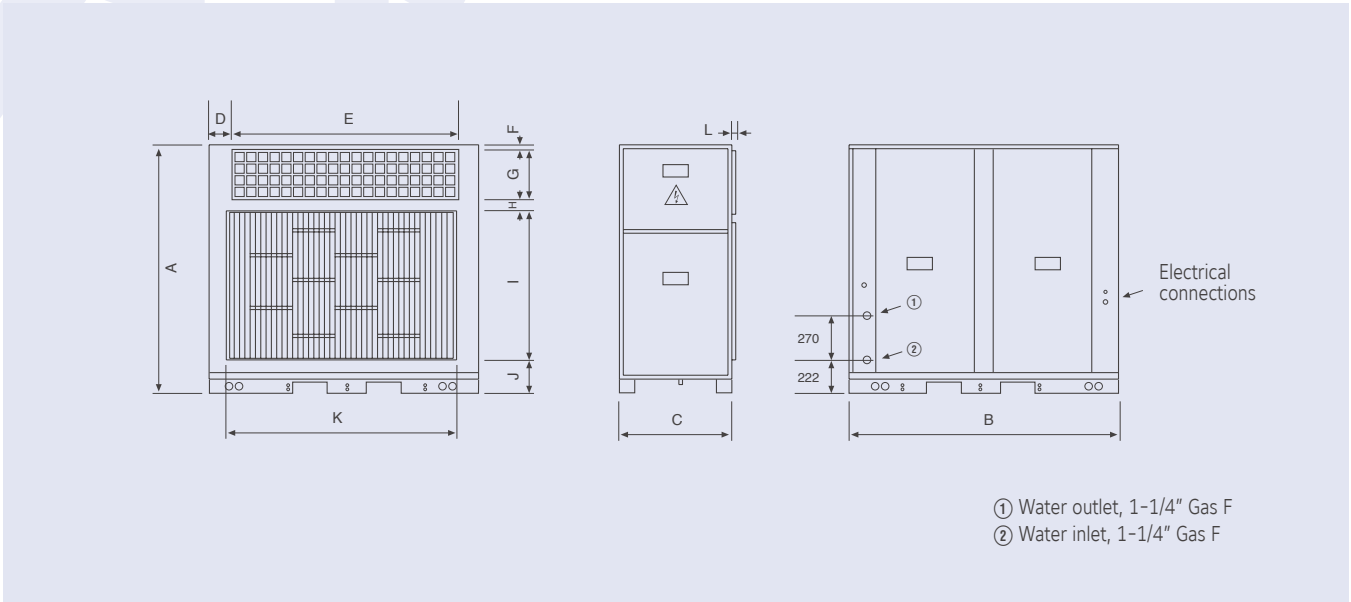

All dimensions in mm. Drawings not a scale.

Unit	A	B	C	D	E	F	G	H	I	J	K	L
YLCD/YLHD 0025 TC	1 526	1 740	785	151	1436	30	324	37	994	141	1476	24

YLCD / YLHD 0040-0070 T/TP

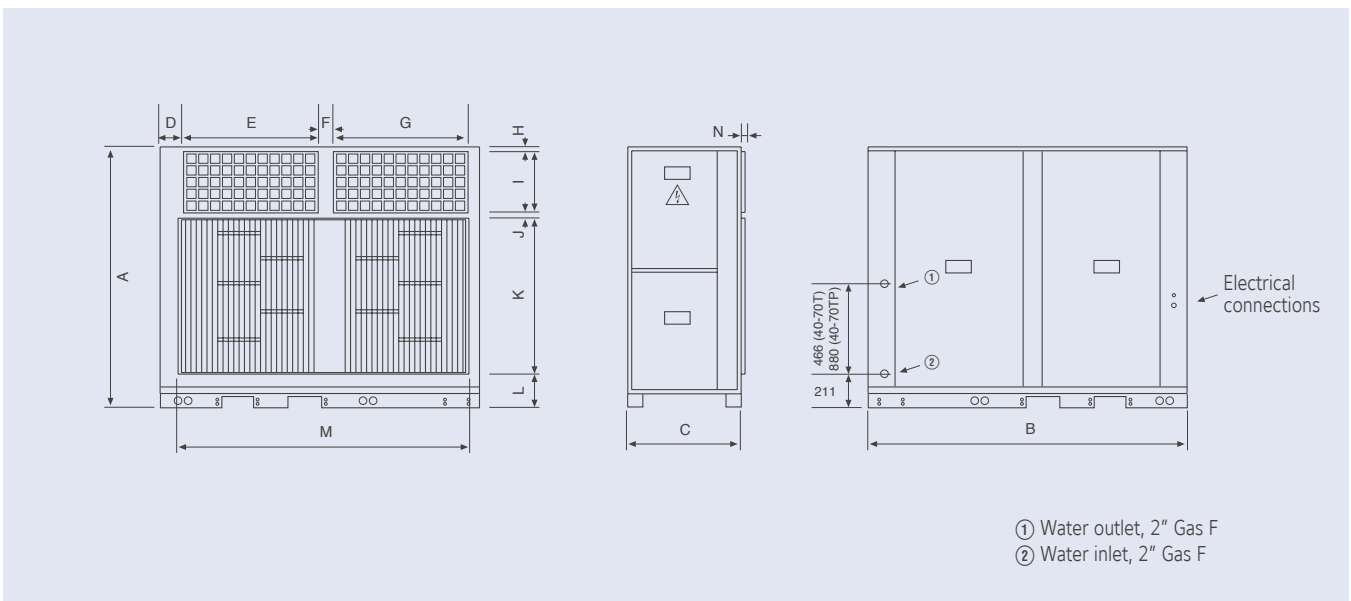

All dimensions in mm. Drawings not a scale.

Unit	A	B	C	D	E	F	G	H	I	J	K	L	M	N
YLCD/YLHD 0040 T/TP	1 794	2 658	897	148	1155	95	1155	30	389	37	1 200	138	2 479	23
YLCD/YLHD 0070 T/TP	1 794	2 658	897	148	1155	95	1155	30	389	37	1 200	138	2 479	23

YLCD-YLHD 0025 to 0150



YLCD / YLHD 0100-0120 T/TP

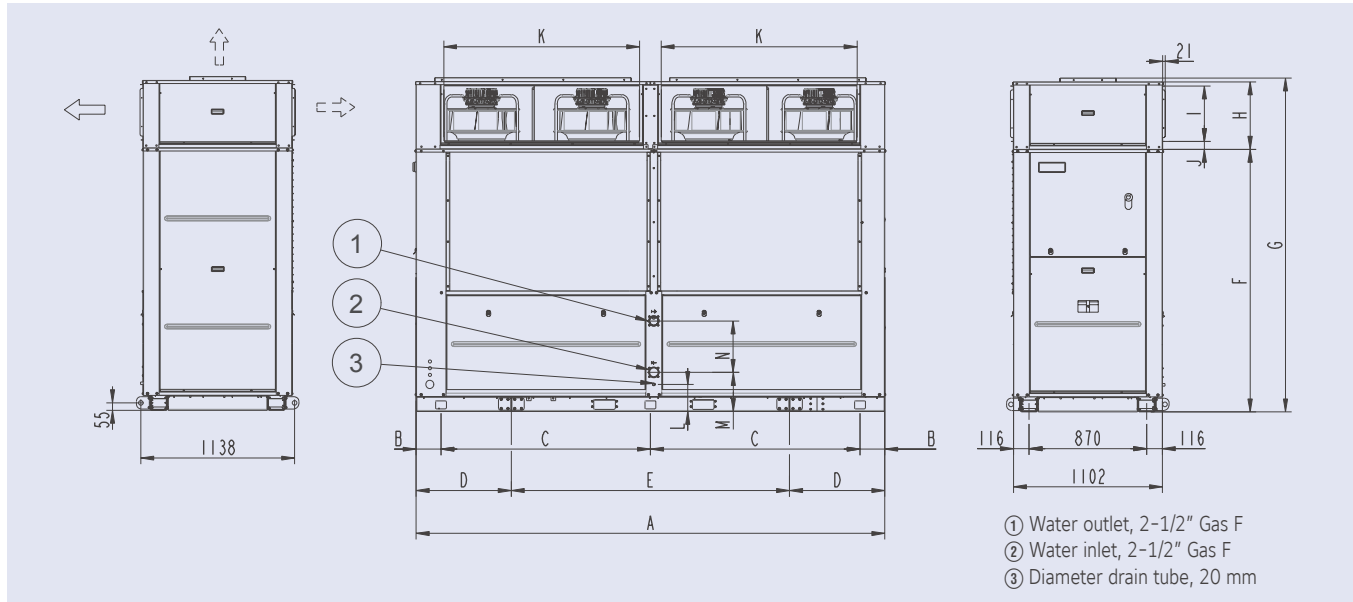

All dimensions in mm. Drawings not a scale.

Unit	A	B	C	D	E	F	G	H	I	J	K	L	M	N
YLCD/YLHD 0100 T/TP	3 466	183	1 550	704	2 058	1 942	2 460	500	410	59	1 450	200	290	380
YLCD/YLHD 0120 T/TP	3 416	183	1 525	604	2 208	1 942	2 460	500	418	55	1 438	200	290	380

YLCD / YLHD 0150 T/TP

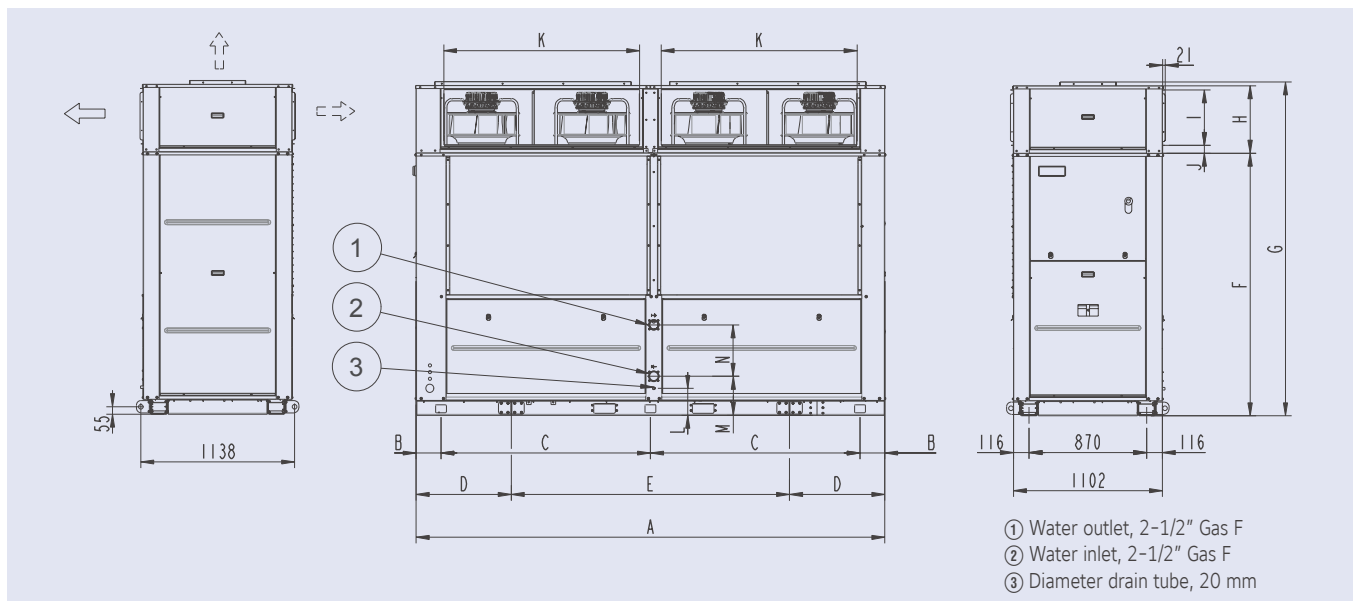

All dimensions in mm. Drawings not a scale.

Unit	A	B	C	D	E	F	G	H	I	J	K	L	M	N
YLCD/YLHD 0150 T/TP	3 768	254	1 630	605	2 558	1 992	2 480	470	386	55	1 617	410	210	458

YCAE Modular air cooled scroll chiller / heat pump

YCAE 065R/S to 0100R/S (CE version)
A complete range from 64 kW up to 99 kW



NEW



Features

Up to 8 modules in one water system; each module can be operated separately. Built-in main water pipe makes it easy to install in the field

Ability to configure modular chillers to fit the space

Installation flexibility for modular chillers will allow you to use all the available space. Many different possible configurations (linear, parallel, star, etc).

Ability to add more modular chillers in the future

Buildings being constructed or occupied in phases do not need the full cooling/heating capacity at the start. Modular chillers allow you to stage the investment by combining modules to obtain the required capacity.

Ability to stock a few models and cover large range

Modular chillers are your solution. Limited numbers of module configurations allow the distribution channel to keep modules in stock.

Quick and easy module combination

Connecting the water piping and cables, installing the sensors and bringing power to the modular(s) makes installation quick and easy.

Full redundancy – Easy parts management

Modularity and the central controller allows you to decide the quantity of modules active at anytime. In the event of maintenance other modules in the system will continue to operate ensuring minimal capacity loss.

Small modules, small components, low noise

Modularity design is based on low capacity modules installed together. Components are carefully selected based on its performance, reliability and low sound attributes. When comparing modular systems with standard chillers, modular chillers provide a lower noise level.

Very easy and intuitive central controller

Modular units, which can manage up to 8 modules per system, are controlled with a single central controller. Central controller sequence enables the units to even out the run hours and prolong the life of the chiller.

Intelligent defrost - For heat pumps

For our air to water heat pumps, defrost must occur. The central controller optimizes the sequencing of the defrost cycle allowing only one module to defrost at a time. This allows the remaining modules to continue to provide heating.



Modular air cooled scroll chiller / heat pump

YCAE 065R/S to 0100R/S



Technical features

Model		YCAE065SME53	YCAE065RME53	YCAE100SME53	YCAE100RME53
Cooling capacity	kW	64.1	64.1	99	99
Heating capacity	kW	-	70	-	103
EER / COP		3.05 / -	3.05 / 3.39	3.16 / -	3.16 / 3.2
ESEER		3.32	3.32	3.65	3.65
Refrigerant charge	kg	2 x 9	2 x 9	3 x 10.5	3 x 10.5
Sound power level	dB(A)	83	83	85	85
Capacity adjustment	%	0, 50, 100	0, 50, 100	0, 33, 66, 100	0, 33, 66, 100
Compressor	Type	Scroll			
	No.	2	2	3	3
Power input	Cooling kW	21	21	31.3	31.3
	Heating kW	-	20.8	-	33.9
Fan	Power input kW	0.9 x 2	0.9 x 2	0.9 x 3	0.9 x 3
	Fan No.	2	2	3	3
	Air flow m³/h	13000 x 2	13000 x 2	13000 x 3	13000 x 3
Water-side heat exchanger	Water pressure drop kPa	50	50	50	50
	Water pipe size mm	114	114	89	89
	Pipe connection	Clamp			
	Water flow m³/h	11.1	11.1	17.2	17.2
Max. operating Current	A	49.3	49.3	74	74
Dimensions	Length mm	2000	2000	2030	2030
	Width mm	1000	1000	1930	1930
	Height mm	2100	2100	2100	2100
Weight	Shipping weight kg	800	840	1180	1240
	Operating weight kg	880	920	1280	1350

Nominal conditions: Cooling capacities in kW given for 7°C water leaving temperature Δt 5°C and 35°C ambient temperature
 Heating capacities in kW given for 45°C water leaving temperature and 7°C ambient temperature

Dimensions and hydraulic connections

YCAE 065R/S

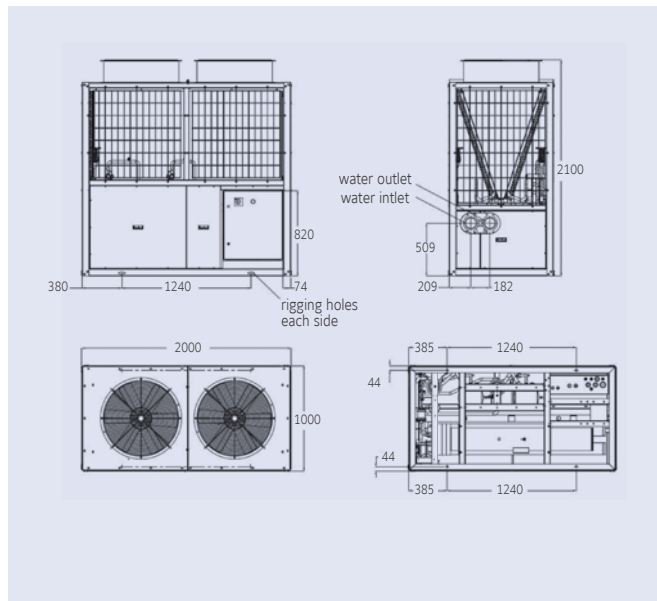

YCAE 100R/S

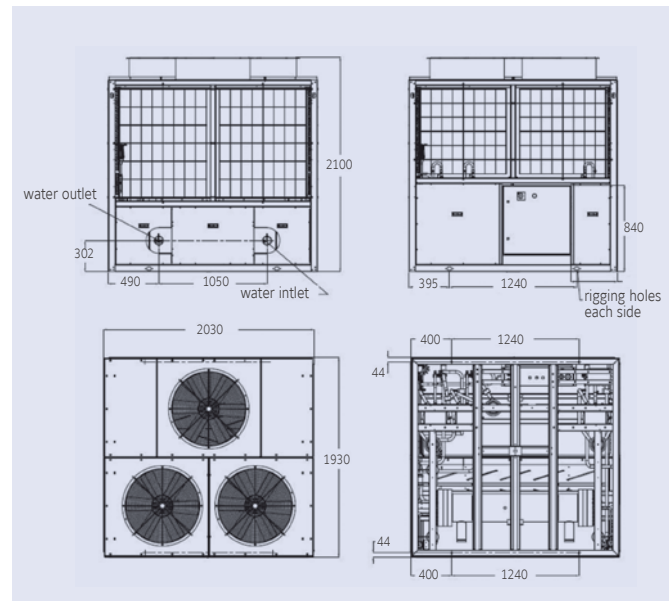

All dimensions in mm. Drawings not a scale.



Manufacturer reserves the rights to change specifications without prior notice.

YLAA

Air-cooled scroll compressor chiller

Cooling capacities from 190 kW to 519 kW



There are 2 versions COOLING ONLY

YLAA SE	Standard Efficiency
YLAA HE	High Efficiency

Options / Accessories

- Soft start
- Power Factor Correction Capacitors
- Low ambient kit
- BMS Interfacing options
- Dual pressure relief valves
- Victaulic coupling
- Flow switch
- Heat recovery option
- Enclosure options
- Sound attenuation options
- Anti-vibration mounts options
- Hydrokits with single and dual pump
- Epoxy Post-coated Dipped Microchannel Coils
- VSD Fans

Features

The **YORK YLAA TEMPO** air-cooled chiller is an environmental leader.

Utilising scroll type compressors and microchannel condenser coil technology the **YLAA** delivers premium efficiency for all air conditioning applications.

YLAA chillers are a self-contained cooling solution that is light-weight and compact for convenient installation on the ground or on building rooftops.



The TEMPO delivers energy efficiency levels that surpasses Eurovent A Class requirements. Aluminium microchannel condenser coil technology is one reason for this premium efficiencies.

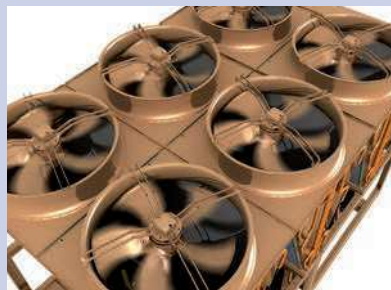

Ultra quiet operation can be obtained through optional dual or low speed fans and a compressor accousitc enclosure.

A single point power connection and optional, factory packaged water pumps, water filter and flow switch provide fast and easy installation.

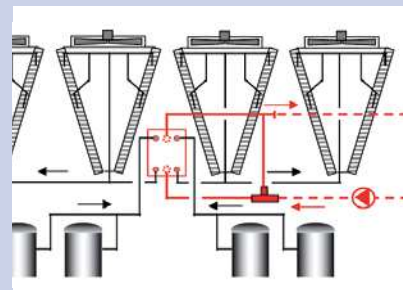

An optional heat recovery feature can be added to provide hot water to 50°C; which is useful for facility heating or hot water preheating.



Air-cooled scroll compressor chiller

YLAA 0180 to 0517

Nominal capacity

YLAA SE Standard	0180	0210	0241	0286	0320	0360	0400	0435	0485
Cooling capacity (kW)	190	205	218	272	310	349	388	423	473
EER	2.97	2.42	2.74	2.62	2.44	2.57	2.45	2.55	2.48
ESEER	3.97	3.43	3.6	3.84	3.63	3.84	3.71	3.75	3.74
ESEER with VSD	-	-	-	-	-	-	-	-	-
Sound power level dB(A)	89	89	86	90	94	94	95	96	96
Sound power level Low Noise Version dB(A)	82	83	84	87	87	87	87	89	89

YLAA HE High Efficiency	0195	0221	0261	0301	0350	0391	0442	0457	0517
Cooling capacity (kW)	198	212	248	295	344	380	426	455	519
EER	3.1	3.2	3.08	2.99	2.95	2.96	2.96	2.9	2.93
ESEER	4.25	4.15	4.08	3.98	3.92	4.12	4.1	3.98	4.16
ESEER with VSD	-	4.44	4.34	4.27	4.28	4.36	4.35	4.30	4.38
Sound power level dB(A)	89	91	90	93	94	95	95	96	96
Sound power level Low Noise Version dB(A)	82	84	87	86	87	88	88	89	89

At leaving chilled water temperature of 7°C, and ambient temperature of 35°C.

Technical data

YLAA SE Standard			0180	0210	0241	0286	0320	0360	0400	0435	0485
Dimensions	Length	mm	2911				3614				
	Width	mm					2242				
	Height	mm					2508				
Operating weight kg			1681	1725	1785	1853	1937	2814	2873	2642	2755

YLAA HE High Efficiency			0195	0221	0261	0301	0350	0391	0442	0457	0517
Dimensions	Length	mm	2911				3614			4769	
	Width	mm					2254				
	Height	mm					2507				
Operating weight kg			1706	1721	1851	2170	2339	2508	3343	3481	3615

YLAA Pump Kit

- Two option levels - basic and full featured - for maximum flexibility
- More impeller size options for better match to customer requirements
- New, smaller pump motors suitable for primary-secondary systems
- VSD option by SQ

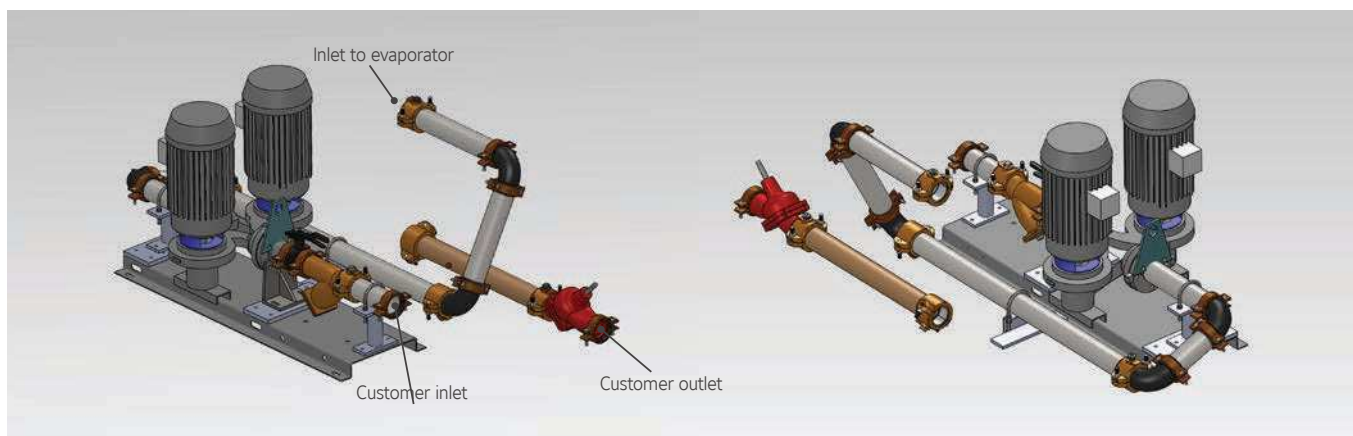

Manufacturer reserves the rights to change specifications without prior notice.

Dimensions and hydraulic connections

YLAA0180SE, 0210SE, 0241SE, 0286SE, 0320SE, 0195HE, 0221HE & 0261HE

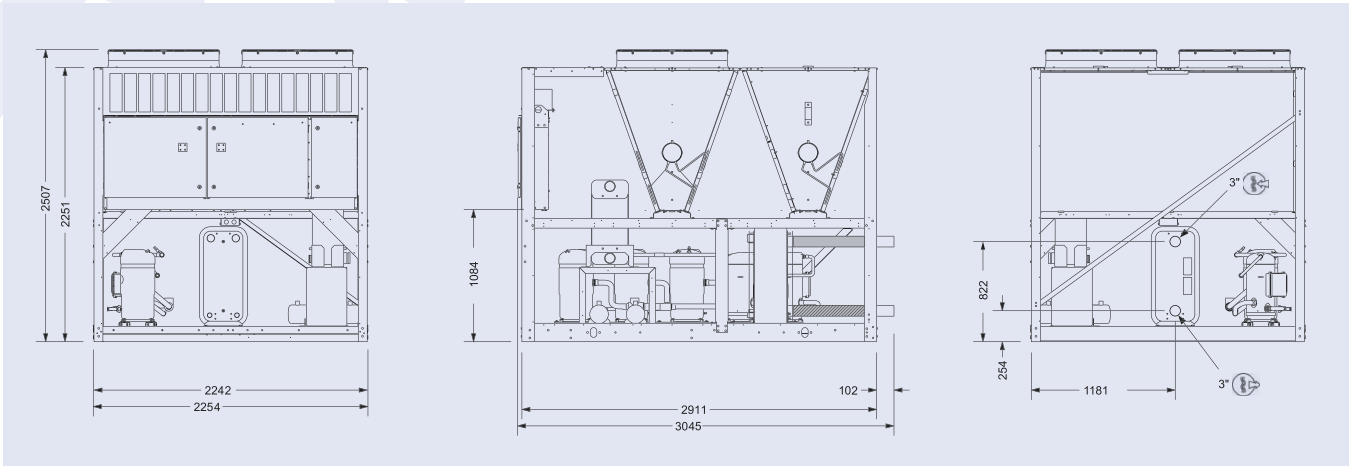

All dimensions in mm. Drawings not a scale.

YLAA0360SE, 0400SE, 0435SE, 0485SE, 0301HE & 0391HE

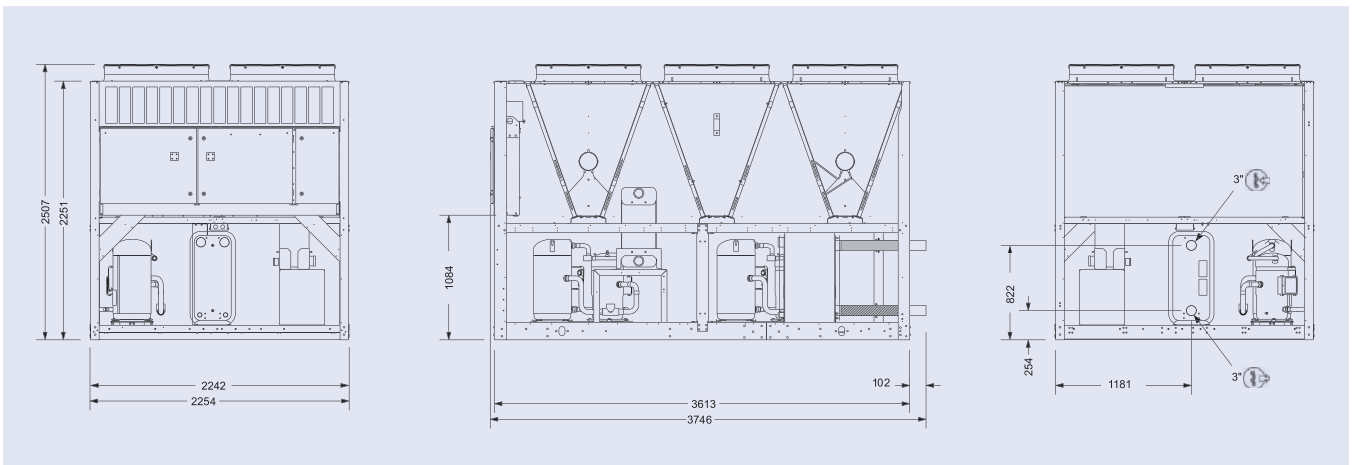

All dimensions in mm. Drawings not a scale.

YLAA 0180 to 0517



YLAA0442HE

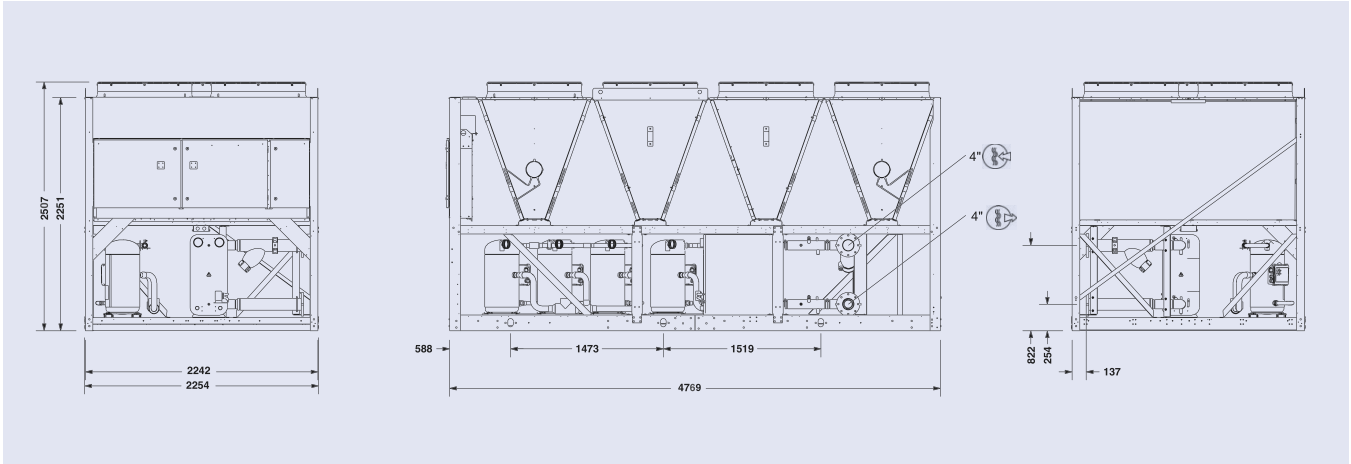

All dimensions in mm. Drawings not a scale.

YLAA0457HE & 0517HE

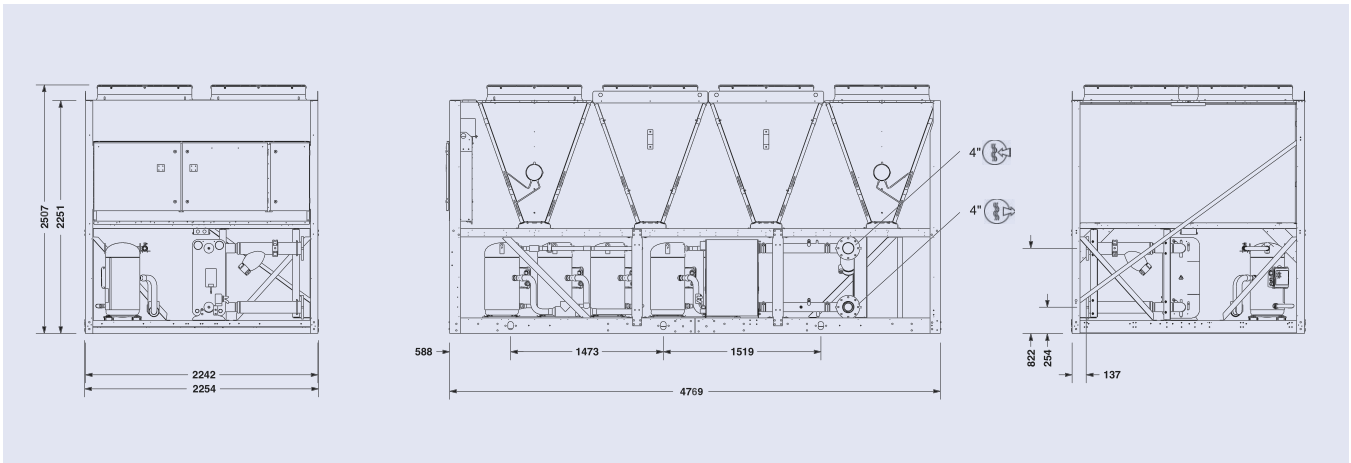

All dimensions in mm. Drawings not a scale.

YLRA

Air cooled heat pump scroll compressor

Cooling capacities from 181 kW to 307 kW

Heating capacities from 200 kW to 327 kW

At Eurovent Standard Conditions all models meet A Class energy efficiency levels for heating mode.



Features

YLRA are available in 6 models, from 200 to 330, with a nominal capacity range from 181 to 307 kW in cooling mode and from 200 to 327 kW in heating mode. Up to 3.99 ESEER with EC fans.

Except for the fans all the units have the same configuration of base units (structure, electrical board, compressors and coils).

Each model is available in the following acoustic versions:

- Basic Low Noise version (BLN): These models are equipped with delta connected fans running at a fixed rpm and are fitted with compressor boxes to reduce noise emissions.
- Super Low Noise version (SLN): Those models are equipped with special inverter fans driven by EC (electronic brushless type), fitted with a variable speed controller which allows the fans to operate at a very low rpm. The chillers are supplied with compressor boxes and soundproof jackets on compressors reducing significantly the noise emissions.

The BLN model is also available in an EC version (developed for high seasonal efficiency) which has the same equipment as that of the standard BLN model, except that the units are equipped with special inverter fans driven by EC (electronic brushless type) motors with integrated electronic inverter, to ensure low energy consumption.

Options / Accessories

- ModBus protocol kit for BMS (standard)
- Lonwork protocol kit for BMS
- Bacnet protocol kit for BMS
- Soft start
- Power factor correction capacitors
- Compressors overload protection
- Condensing control kit (down to -14 °C ambient temperature in cooling mode)
- Polar version (down to -18 °C ambient temperature in heating mode)
- Double set point
- HP & LP manometers
- E-coating Al/Cu condenser coils
- Chiller grilles
- Desuperheater
- Optional hydro kits
- Remote ON/OFF control
- Remote keyboard panel
- Sequencer unit
- Spring isolators
- Flow switch
- Water filter

Heat pump scroll compressor

YLRA 0200 to 0330



Nominal capacity

YLRA BLN versions	0200	0230	0260	0280	0300	0330
Cooling capacity (kW)	181.3	213.6	243.7	261.1	287.8	307.4
EER	2.93	2.92	2.91	2.88	2.92	2.97
Energy Efficiency Class	B	B	B	C	B	B
ESEER	3.6	3.71	3.71	3.65	3.6	3.64
EER (EC units)	2.97	2.96	2.95	2.91	2.96	3.02
ESEER (EC units)	3.71	3.83	3.83	3.78	3.71	3.71
Heating capacity (kW)	200.1	229	262.3	279.6	305.6	327.2
COP	3.22	3.23	3.21	3.20	3.27	3.21
COP (EC units)	3.28	3.27	3.26	3.25	3.27	3.26
Energy Efficiency Class	A	A	A	A	A	A
Sound power level (dBA) *	92	92	93	93	94	95
Sound pressure at 10 m (dBA) **	60	60	61	61	62	63

YLRA SLN versions	0200	0230	0260	0280	0300	0330
Cooling capacity (kW)	168.5	194.7	224	238.5	263.3	283.5
EER (EC units)	2.7	2.54	2.58	2.5	2.55	2.66
Energy Efficiency Class	C	D	D	D	D	D
ESEER (EC units)	3.86	3.99	3.95	3.93	3.86	3.79
Heating capacity (kW)	189.8	219.8	250.8	267.1	294.7	315
COP	3.27	3.27	3.25	3.24	3.26	3.25
Energy Efficiency Class	A	A	A	A	A	A
Sound power level (dBA) *	82	82	83	83	85	86
Sound pressure at 10 m (dBA) **	50	50	51	51	53	54

Cooling Capacity at Eurovent Conditions, entering/leaving chilled water temperature 12°C/7°C, ambient temperature 35°C

Heating Capacity at Eurovent Conditions, entering/leaving hot water temperature 40°C/45°C, ambient temperature 7°C

* Sound levels are at fully loaded conditions. Sound power level values refer to ISO standard 3744 and Eurovent 8/1

** Sound pressure levels refer to ISO Standard 3744, parallelepiped shape

Technical data

YLRA BLN versions			0200	0230	0260	0280	0300	0330
Dimensions	Length	mm	3 500				4 550	
	Width	mm	2 150					
	Height	mm	2 600					
Operating weight (kg)			1 858	1 993	2 216	2 226	2 806	2 899
Additional weight EC versions (kg)			50	50	60	60	70	80

YLRA SLN versions			0200	0230	0260	0280	0300	0330
Dimensions	Length	mm	3 500				4 550	
	Width	mm	2 150					
	Height	mm	2 600					
Operating weight (kg)			1 908	2 043	2 276	2 286	2 876	2 979



Manufacturer reserves the rights to change specifications without prior notice.

Dimensions and hydraulic connections

YLRA 0200 to 0280

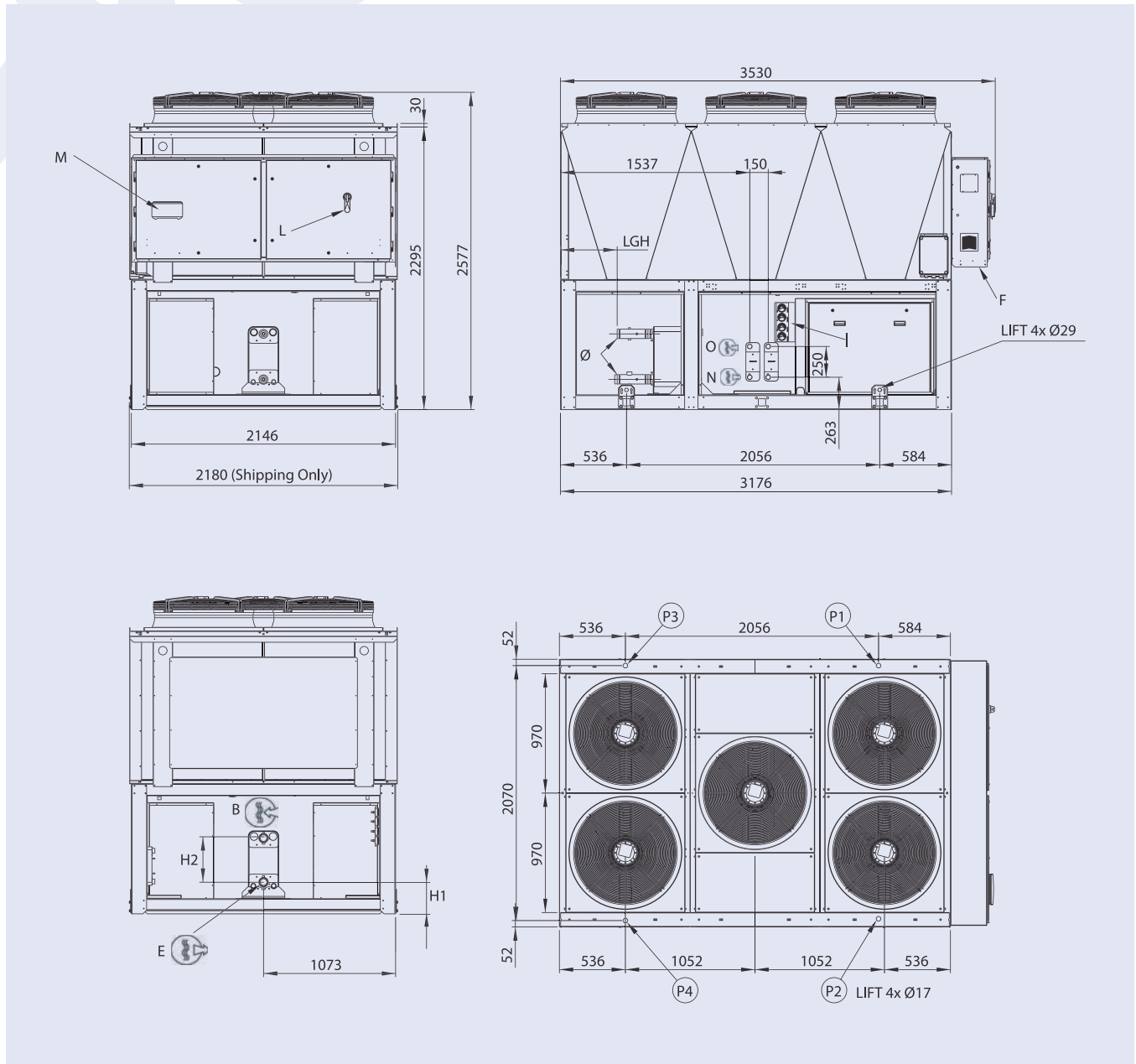

All dimensions in mm. Drawings not a scale.

NOTES:

- B, E** - WATER CONNECTION GAS M
- F** - ELECTRICAL POWER SUPPLY
- I** - GAUGE KIT (ACCESSORY)
- L** - MAIN SWITCH
- M** - CONTROL KEYPAD / DISPLAY

OPTIONAL DESUPERHEATER

- N** - WATER INLET Ø1" GAS M
- O** - WATER OUTLET Ø1" GAS M

P1, P2, P3, P4 AVM POSITION

Size	LGH	Ø
YLRA 0200	440	2" 1/2 Victaulic Ø 76.1 mm
YLRA 0230 to 0280	344	3" Victaulic Ø 88.9 mm

Size	H1	H2
YLRA 0200	246	370
YLRA 0230 to 0280	205	520

Dimensions and hydraulic connections

YLRA 0300 and 0330

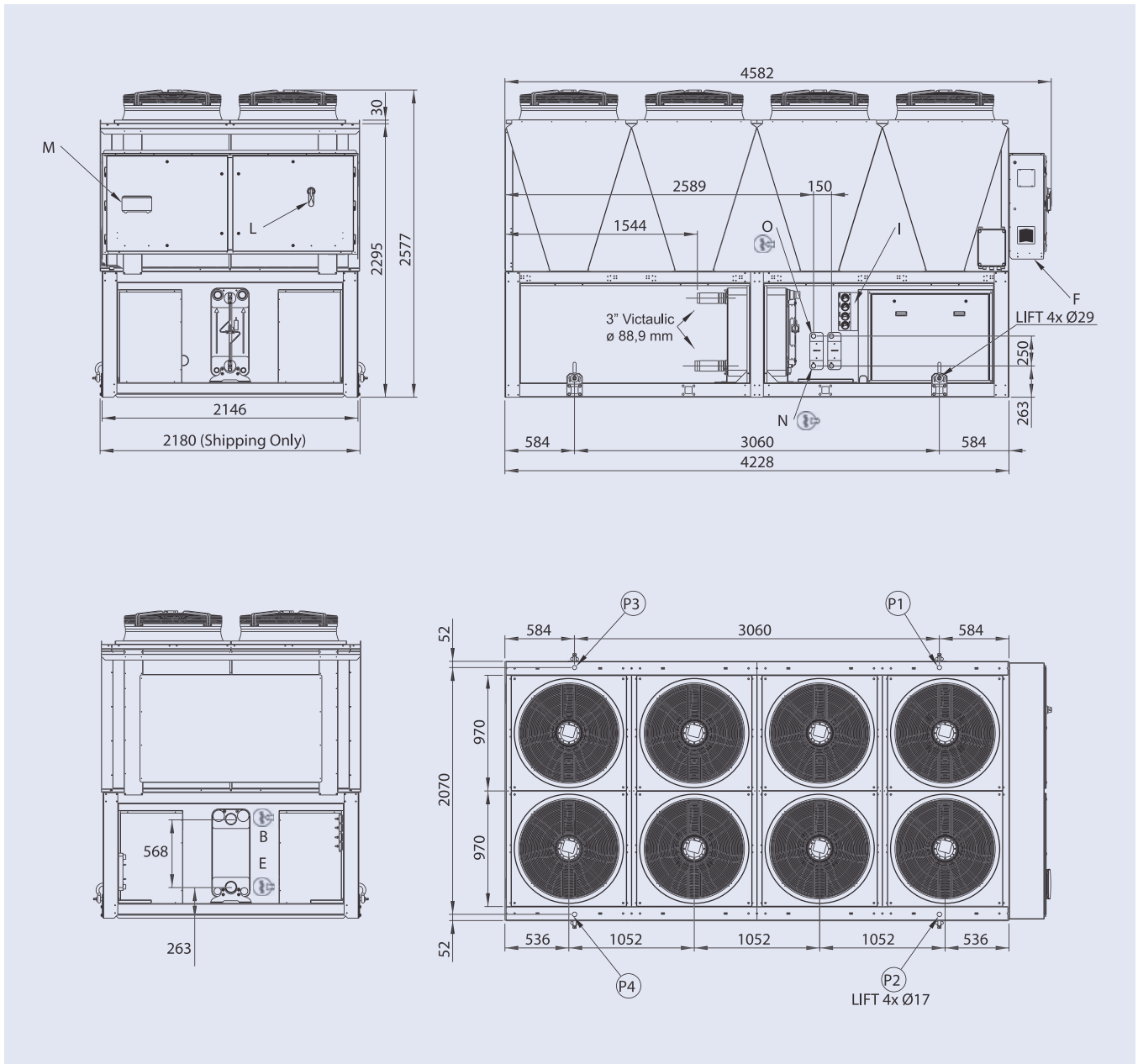

All dimensions in mm. Drawings not a scale.

NOTES:

- B, E** - WATER CONNECTION 3-GAS M Ø88.9 mm
- F** - ELECTRICAL POWER SUPPLY
- I** - GAUGE KIT (ACCESSORY)
- L** - MAIN SWITCH
- M** - CONTROL KEYPAD / DISPLAY

- OPTIONAL DESUPERHEATER
- N** - WATER INLET Ø1" GAS M
- O** - WATER OUTLET Ø1" GAS M

P1, P2, P3, P4 AVM POSITION

YVAA Air-cooled VSD screw chiller

Cooling capacities from 471 kW to 1660 kW

At Eurovent Standard Conditions this equipment meets A Class energy efficiency levels.



Note: this picture is showing aesthetics enclosures, contact your York office for additional information

Features

- Reduce your annual energy costs by as much as 30%
- Reduce your sound levels by up to 16 dBA to meet tighter regulations
- Enhance your flexibility with a variety of chiller options to fit your needs
- Minimise your environmental impact dramatically
- Lower your part load energy and night time sound levels with inverter fans and compressors
- Deliver increased motor longevity and increased chiller reliability with low starting currents
- Cut your operational expenses with a high chiller power factor at all loads
- Improve your peace of mind knowing we stand behind every chiller

Options / Accessories

- BMS Interfacing options
- Advanced Controls (Silent night™, Quick restart)
- Low temperature application options
- Dual pressure relief valves
- Flow switch
- Epoxy treatment Microchannel Coils
- Fan options
- Enclosure options
- Sound attenuation options
- Anti-vibration mounts options
- Desuperheater

Photo courtesy of the ITCM lab of the Ecole Polytechnique Fédérale de Lausanne, Switzerland

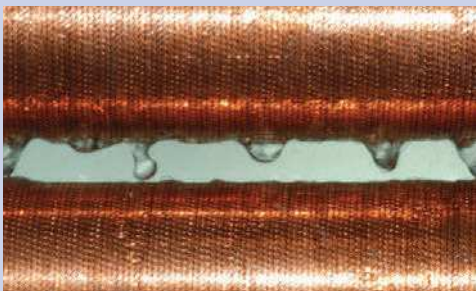

Reduce refrigerant charges by up to 15% beyond traditional chiller designs with the YVAA's falling-film evaporator and microchannel condenser coil technology.



A more efficient chiller means less electricity generation, which reduces greenhouse gas emissions, water consumption – and your environmental footprint. The sustainability advantages of the YVAA chiller give you the opportunity to **earn points in the LEED® and BREEAM® building certification programs.**

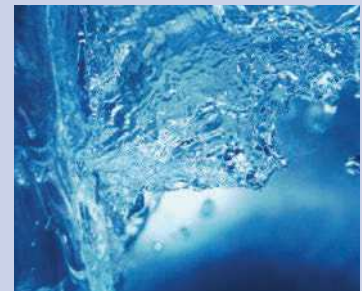

Air-cooled VSD screw chiller

YVAA 0153 to 0500



Application flexibility (*) example of selections

YVAA	0153	0165	0178	0183	0195	0198	0200	0213	0215	0218	0233	0245	0248	0263	0273
Cooling capacity (kW)	471	549	569	573	588	639	614	658	698	738	748	768	808	812	867
Full Load Efficiency (EER)	3.04	3.13	3.22	3.07	3.09	3.17	2.78	3.11	3.16	3.13	3	3.08	3.15	3.06	3.14
Part Load Efficiency (ESEER)	4.2	4.26	4.39	4.27	4.26	4.34	3.8	4.29	4.31	4.29	4.22	4.34	4.32	4.25	4.32
Sound power level (dBA)	95	97	94	96	94	95	95	97	97	95	97	95	96	98	98

YVAA	0275	0278	0295	0303	0305	0308	0323	0318	0343	0345	0373	0375	0413	0500
Cooling capacity (kW)	898	933	948	964	971	997	1002	1022	1017	1047	1077	1118	1221	1455
Full Load Efficiency (EER)	3.02	3.13	3.05	3.06	3.03	3.12	3.1	3.18	3.06	3.14	3.07	3.14	3.12	3.03
Part Load Efficiency (ESEER)	4.31	4.38	4.37	4.3	4.29	4.47	4.38	4.34	4.3	4.43	4.27	4.37	4.31	4.17
Sound power level (dBA)	96	96	95	99	97	97	99	97	97	97	97	97	101	101

Cooling Capacity at Eurovent Conditions, entering/leaving chilled water temperature 12°C/7°C, ambient temperature 35°C

Sound Pressure according to Eurovent conditions.

(*) YVAA is a tailor and tune chiller. Its performance will be factory-adjusted to match the exact site requirements based on the specific project operating conditions.

The table above shows only a representative sample of performance points based on generic project operating conditions. For tailored and tuned performance based on your specific project requirements, and for more information, please contact your Johnson Controls representative.

Technical data

YVAA		0153	0165	0178	0183	0195	0198	0200	0213	0215	0218	0233	0245	0248	0263	0273	
Dimensions	Length	mm	5163	6280	7397	6274	7397	8514	5741	7397	7397	8514	7397	8514	9631	8514	8514
	Width	mm	2241				2244		2241		2244		2241		2244		
	Height	mm	2401				2405		2401		2405		2401		2405		
Operating weight kg			5990	6247	7554	6208	6551	7012	6977	6589	7668	8011	6793	8100	8445	7151	8314
Refrigerant charge kg			160	172	204	150	164	189	186	160	204	218	182	216	228	192	240

YVAA		0275	0278	0295	0303	0305	0308	0323	0318	0343	0345	0373	0375	0413	0500	
Dimensions	Length	mm	8514	9631	9631	9631	10748	10748	9631	11865	10748	11865	11864	11864	11864	11865
	Width	mm	2244													
	Height	mm	2405													
Operating weight kg			8651	8996	9201	9007	9546	8665	9362	9891	9704	10049	12086	11169	10558	12951
Refrigerant charge kg			242	246	261	248	268	243	268	277	282	286	353	302	365	368

YVFA, Air-cooled VSD screw chiller with integrated Free-cooling

Providing the lowest possible operating costs

YORK® YVFA chillers deliver the lowest possible operating cost by combining superior engineering and technology in a packaged design that's simple to own and operate.

Advanced technologies include:

- Industry-leading variable-speed drive (VSD) that allows YVFA compressors to operate efficiently across all cooling-load and ambient-temperature conditions.
- High-efficiency, air-to-liquid "free-cooling" coils, designed by our heat transfer experts, reduce or eliminate the need for mechanical cooling when ambient conditions allow. Plus, the coils are integrated within the chiller footprint to conserve space.
- Intelligent controls that optimize energy use year-round, constantly evaluating conditions and controlling bypass valves to reduce pump energy when free cooling is not beneficial.
- Plus, performance is assured by AHRI certification, the first time certification has been given to an air-cooled screw chiller with free cooling.

For additional information, please contact your Johnson Controls Sales Representative.

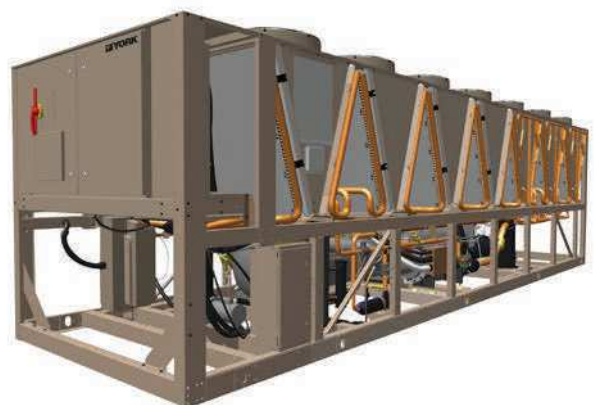

Manufacturer reserves the rights to change specifications without prior notice.

Dimensions and hydraulic connections

All drawings are for two pass evaporator. For other configurations, please, contact JCI.

YVAA 0153 & 0200

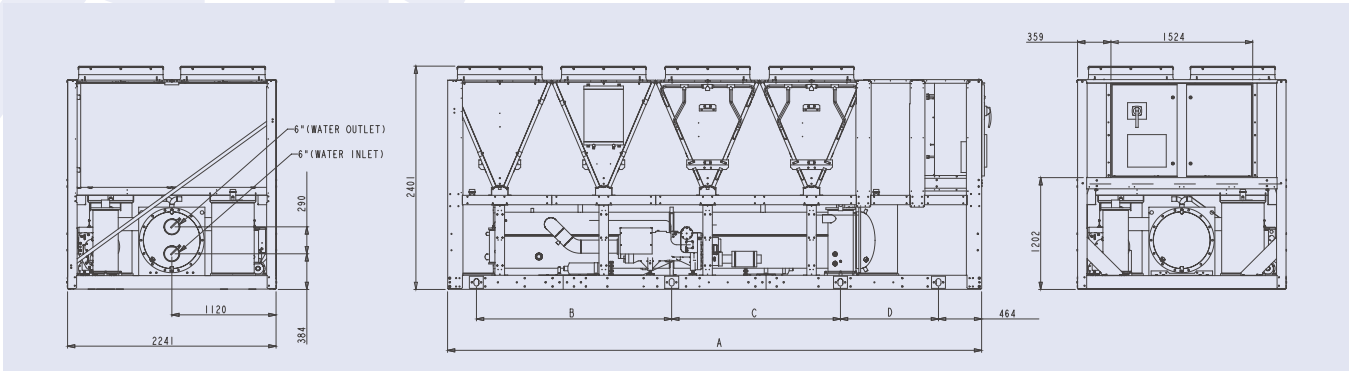

Unit frame	A	B	C	D
YVAA 0153	5 163	1 929	1 425	1 048
YVAA 0200	5 741	2 098	1 814	1 054

All dimensions in mm. Drawings not a scale.

YVAA 0165 & 0183

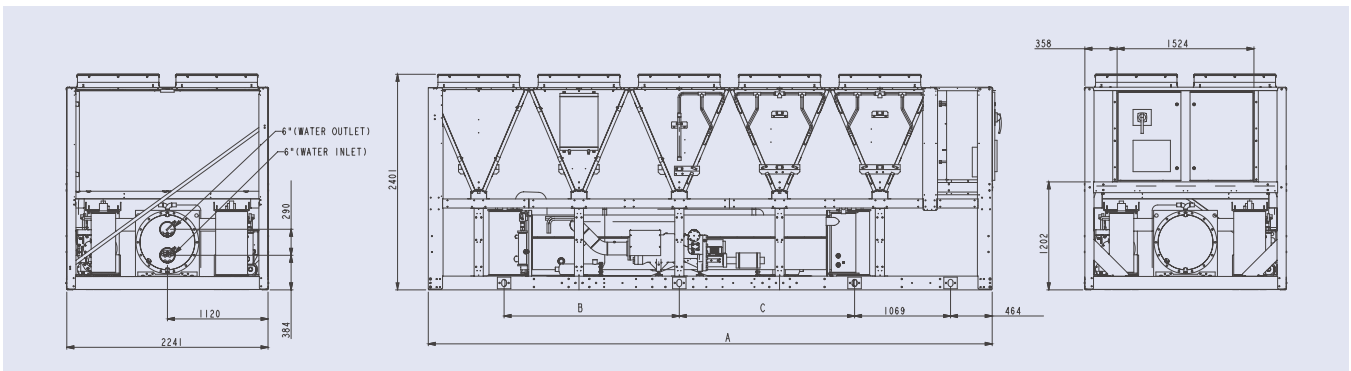

Unit frame	A	B	C	D
YVAA 0165	6 280	1 951	1 952	1 048
YVAA 0183	6 274	1 962	2 104	1 054

All dimensions in mm. Drawings not a scale.

YVAA 0178, 0195, 0213, 0215 & 0233

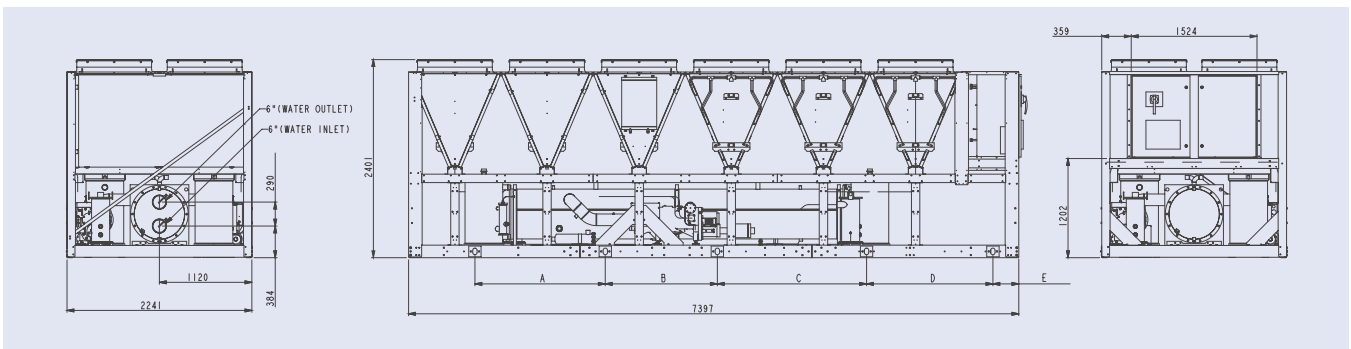

Unit frame	A	B	C	D	E
YVAA 0178 & 0215	1 581	1 358	1 809	1 531	314
YVAA 0195 & 0213	1 159	2 125	2 103	1 069	464
YVAA 0233	1 464	1 971	1 951	1 069	464

All dimensions in mm. Drawings not a scale.

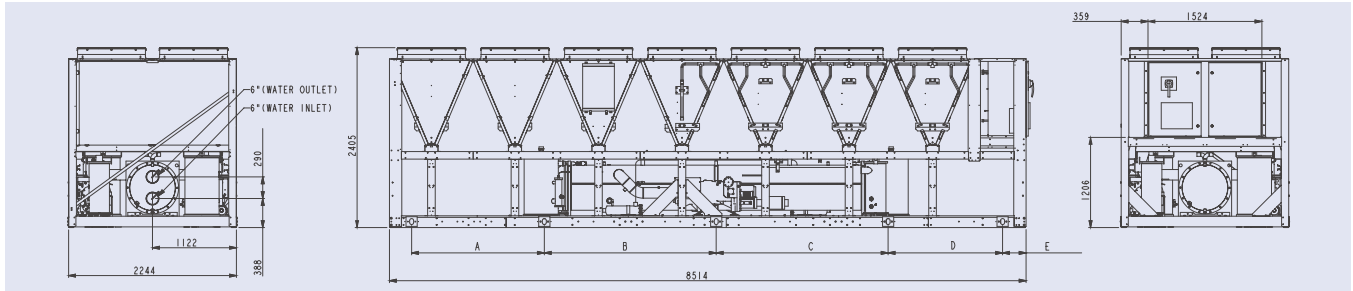

Unit frame	A	B	C	D	E
YVAA 0198 & 0263	2 214	1 971	1 951	1 069	464
YVAA 0218	1 774	2 299	2 299	1 531	314
YVAA 0245	2 129	2 299	2 256	1 069	464
YVAA 0273	2 049	1 568	1 529 + 1 228	1 531	314
YVAA 0275	1 501	2 115	1 529 + 1 228	1 531	314

All dimensions in mm. Drawings not a scale.

YVAA 0248, 0278, 0295, 0303, & 0323

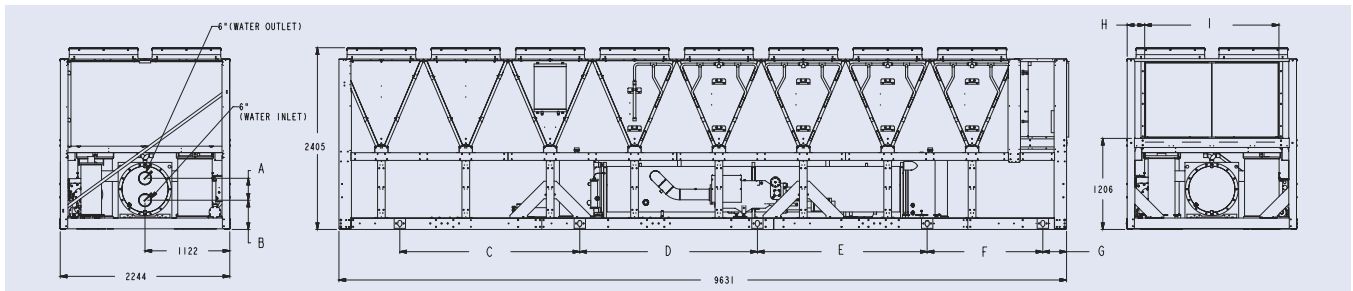

Unit frame	A	B	C	D	E	F	G	H	I
YVAA 0248	290	388	2 381	2 299	2 299	1 531	359	359	1 524
YVAA 0278	355	394	2 656	1 568	1 529 + 1 228	1 531	314	359	1 524
YVAA 0295	355	394	1 467	2 807	2 706	1 531	314	232	1 778
YVAA 0303	290	388	2 381	2 351	2 247	1 531	314	232	1 778
YVAA 0323	355	394	2 656	1 568	1 529 + 1 228	1 531	314	232	1 778

All dimensions in mm. Drawings not a scale.

YVAA 0305, 0308 & 0343

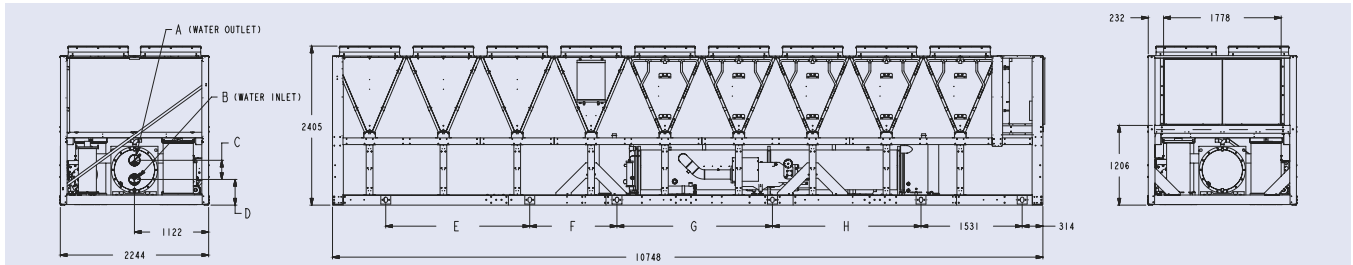

Unit frame	A	B	C	D	E	F	G	H
YVAA 0305	6"	6"	290	388	2 178	1 320	2 351	2 247
YVAA 0308	8"	8"	355	394	2 433	2 433	1 620 + 1 477	1 228
YVAA 0343	8"	8"	355	394	2 433	2 433	1 568 + 1 529	1 228

All dimensions in mm. Drawings not a scale.

YVAA 0318, 0345, 0373, 0375, 0413 & 0500

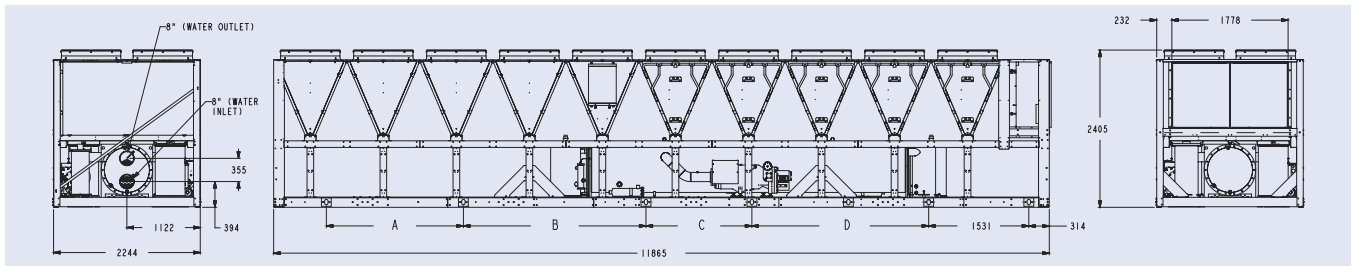

Unit frame	A	B	C	D
YVAA 0318	2 097	2 793	1 619	1 477 + 1 228
YVAA 0345	2 097	2 793	1 568	1 529 + 1 228
YVAA 0373 / 0375 / 0413	3 397	1 623	1 437	2 757
YVAA 0500	3 701	1 318	1 437	2 757

All dimensions in mm. Drawings not a scale.

YMWA / YMRA

Water-cooled cooling only, remote condenser and heat pump scroll compressor chiller

Cooling capacities from 20 kW to 190 kW



Features

- Scroll compressors (single or tandem)
- Higher EER and COP
- 2 different frames / configurations:
 - 1 compressor / 1 circuit up to 45 kW
 - 2 compressors / 1 circuit from 50 to 190 kW
- Reduced refrigerant charge
- Condensing pressure control
- "Plug and Play" units

Same cabinet w/o or with factory mounted hydrokit (one or two pumps). More compact and slim.

Available versions

14 available YMWA sizes in three versions:

- 1) **YMWA-CO** : Cooling only
- 2) **YMRA** : Remote condenser
- 3) **YMWA-HP** : Reversible heat pump

Nominal capacity and technical data

YMWA-CO	0020	0025	0030	0035	0040	0045	0050	0060	0075	0090	0120	0150	0170	0190
Cooling Capacity (kW)	21.2	26.2	31.1	34.8	39.2	46.6	50.9	61.1	77.3	91.1	118.4	147.1	170	192.7
EER	4.58	4.54	4.46	4.53	4.48	4.57	4.29	4.48	4.48	4.38	4.46	4.46	4.50	4.51
Length /Width / Height (mm)	821 / 455 / 1350						1210 / 850 / 1500							
Operating weight (kg)	156	176	174	179	185	203	440	491	540	591	837	966	1041	1145
YMRA	0020	0025	0030	0035	0040	0045	0050	0060	0075	0090	0120	0150	0170	0190
Cooling Capacity (kW)	20.9	26.0	31.3	34.8	39.3	46.2	51.2	61.7	77.8	91.4	118.7	147.6	169.4	193.2
Length /Width / Height (mm)	821 / 455 / 1350						1210 / 850 / 1500							
Operating weight (kg)	144	164	166	166	172	172	376	404	439	466	678	762	813	874
YMWA-HP	0020	0025	0030	0035	0040	0045	0050	0060	0075	0090	0120	0150	0170	0190
Cooling Capacity (kW)	20.8	26	30.1	34	38.1	45.5	49.9	58.9	76.1	88.6	114.9	144.3	165.7	185.4
Heating Capacity (kW)	23.8	29.1	33.8	38.8	43.2	51.6	57.7	68.2	86.3	102.2	132	164.2	190.1	212.3
EER / COP	4.45/4.03	4.47/4.00	4.28/3.88	4.35/3.94	4.33/3.92	4.39/4.00	4.15/3.98	4.24/3.96	4.36/4.07	4.20/4.04	4.26/4.07	4.34/4.11	4.34/4.09	4.28/4.09
Length /Width / Height (mm)	821 / 455 / 1350						1210 / 850 / 1500							
Operating weight (kg)	159	181	179	184	190	208	448	499	551	602	850	983	1058	1162

YMWA-CO: Standard Eurovent LCP/W/AC conditions in cooling mode: evaporator EWT/LWT 12°C/7°C, condenser EWT/LWT 30°C/35°C

YMRA: Evaporator EWT/LWT 12°C/7°C, condensing temperature 40°C

YMWA-HP: Standard Eurovent LCP/W/AC conditions in cooling mode: evaporator EWT/LWT 12°C/7°C, condenser EWT/LWT 30°C/35°C

YMWA-HP: Standard Eurovent LCP/W/AC conditions in heating mode: evaporator EWT/LWT 10°C, condenser EWT/LWT 40°C/45°C

Dimensions and hydraulic connections

YMWA-CO/HP 0020-0045

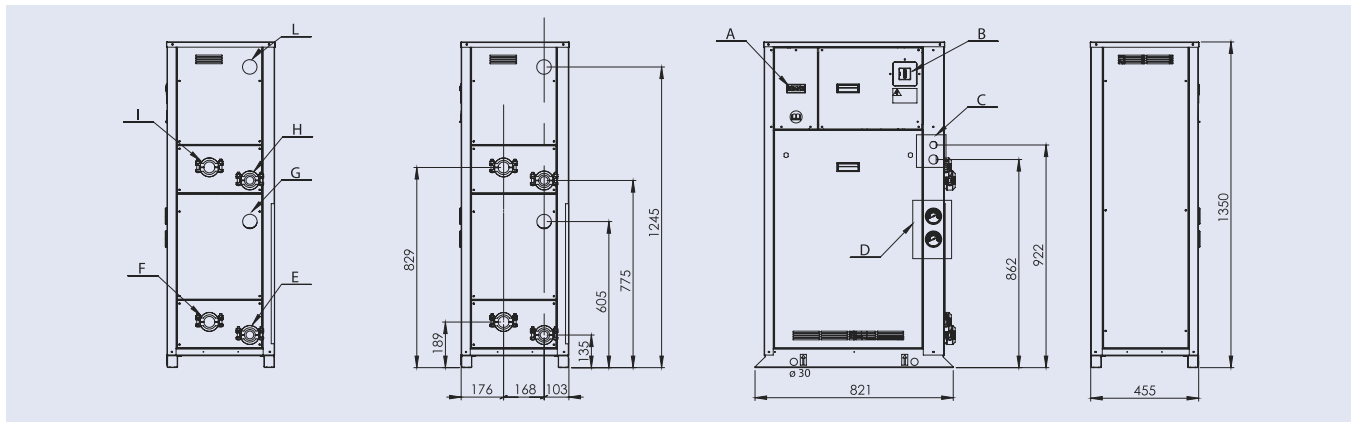

A	Control display	D	Gauge kit	YMRA Sizes	In	Out
B	Main switch	E, F, G	Water evaporator connections Ø 1 1/2" victaulic	020	H Ø 5/8"	L Ø 5/8"
C	Auxiliary lines, electrical connection	H, I, L	Water condenser connections Ø 1 1/2" victaulic	025-045	H Ø 5/8"	L Ø 7/8"

All dimensions in mm. Drawings not a scale.

YMWA-CO/HP 0050-0190 without Hydrokit

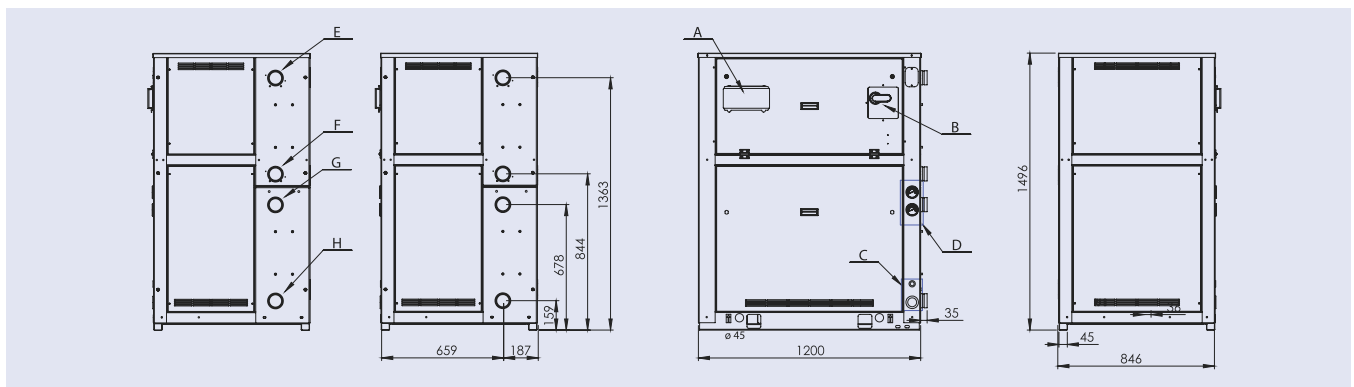

A	Control display	D	Gauge kit
B	Main switch	G, H	Water evaporator connections Ø 1 1/2" victaulic
C	Auxiliary lines, electrical connection	E, F	Water condenser connections Ø 1 1/2" victaulic

All dimensions in mm. Drawings not a scale.

YMWA-CO/HP 0050-0190 with Hydrokit

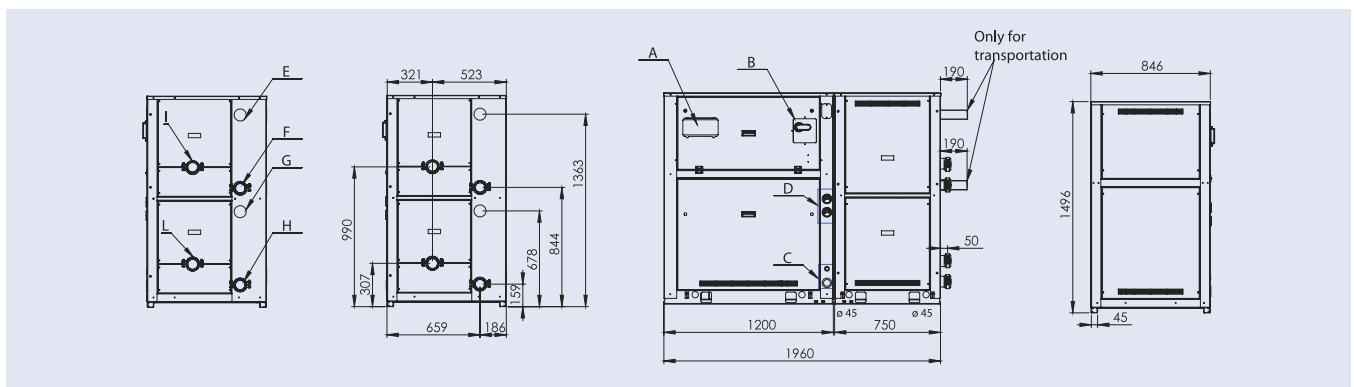

A	Control display	D	Gauge kit	YMRA Sizes	In	Out
B	Main switch	G, H, L	Water evaporator connections Ø 1 1/2" victaulic	050-060	F Ø 5/8"	E Ø 7/8"
C	Auxiliary lines, electrical connection	E, F, I	Water condenser connections Ø 1 1/2" victaulic	075-090	F Ø 7/8"	E Ø 1 1/8"
				120	F Ø 7/8"	E Ø 1 3/8"
				150	F Ø 7/8"	E Ø 1 5/8"
				170-190	F Ø 1 1/8"	E Ø 1 5/8"

All dimensions in mm. Drawings not a scale.



Manufacturer reserves the rights to change specifications without prior notice.

YCSE / YCRE Style C

Water-cooled or remote air-cooled screw compressor chiller

Cooling capacities from 140 kW to 240 kW

NEW



YORK® YCSE Style C chiller is designed for water or water-glycol cooling. It is designed for indoor installation in a plant room. The unit is completely factory assembled with all interconnecting refrigerant piping and wiring ready for field installation. **YCSE** unit is pressure tested, evacuated, and fully factory charged with refrigerant R134a and oil in each of the independent refrigerant circuits. After assembly, an operational test is performed with water flowing through the evaporator and condenser to ensure that each refrigerant circuit operates correctly..

Features

Efficient screw compressors

Highly efficient the **YORK® YCSE Style C** offers the highest standard of reliability and economical operation utilizing twin-screw rotor technology and fully modulating compressor slide valve unloading, together with low inrush current star delta starters. To further improve the operating efficiency the leaving liquid temperature can be remotely reset.

Quiet operation

The compressor has been designed so that there is minimal external gas pulsations and integral oil separators resulting in very low sound and vibration levels.

Small footprint

The compact design is ideally suited for reduced base area locations. The unit frame is manufactured from heavy gauge galvanized steel coated with baked-on powder paint.

Options / Accessories

- BMS Interface (Modbus, Bacnet)
- Compressor Circuit Breaker
- Power Meter
- Soft Starter
- Heat pump sensor kit
- Evaporator Heater
- Cable Power Routing
- High Leaving Evaporator temperature
- High Condenser Water and glycol options
- Suction Pressure Relief Valve (single/dual)
- Dual Compressor safety valve
- Suction and/or Discharge stop valves
- Water connection flanges
- Differential Water Pressure Switch
- Water Flow Switch and Water Filter
- Anti-vibration mounts (rubber or springs)

Nominal capacity and technical data

Model	YCSE				YCRE		
	0141	0181	0221	0241	0141	0181	0221
Cooling Capacity (kW) *	140	180	215	239	135	175	215
EER	4.83	4.80	4.70	4.71	Not Applicable		
ESEER	5.35	5.69	5.71	5.72			
Sound power level (dBA)	88	89	90	91	88	89	90
Length / Width / Height (mm)	Base 1 378 max / 806 / 1 681						
Operating weight (kg)	860	950	1 040	1 075	765	835	900

* YCSE: At 35°C leaving condenser liquid temperature and 7°C leaving chilled liquid temperature according to EUROVENT calculation EN14511:2011

* YCRE: At 45°C condensing temperature and 7°C leaving chilled liquid temperature

Dimensions and hydraulic connections

YCSE 0141 to 0241

NB1	Electrical Box
NB2	Customer Wiring Entry (both sides)
NB3	2 1/2" Victaulic Connection
NB4	76.1 mm Welded Connection

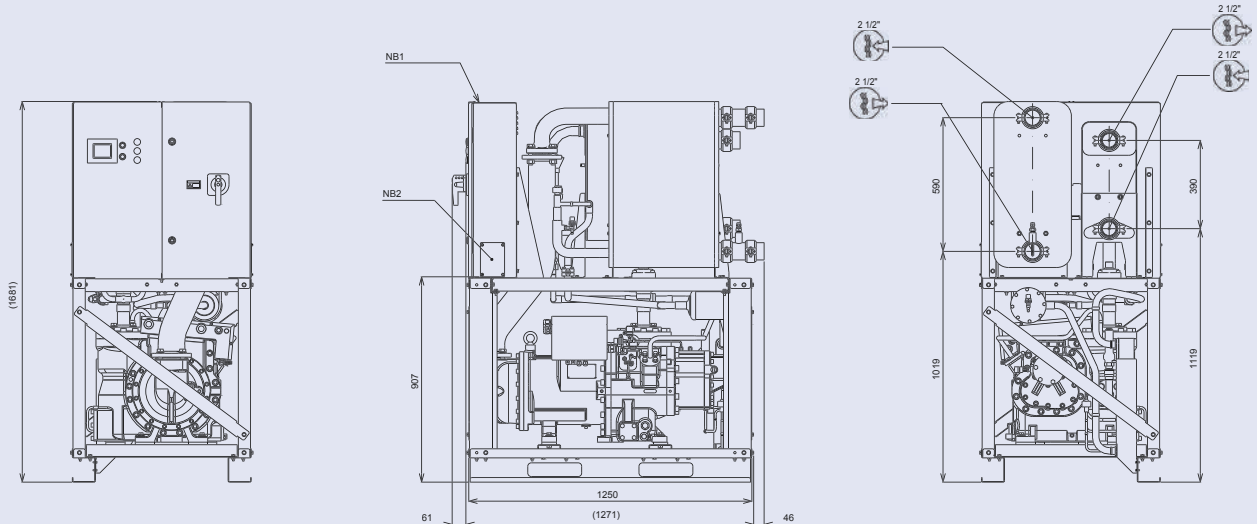

All dimensions in mm. Drawings not a scale.

YCRE 0141 to 0221

NB1	Electrical Box
NB2	Customer Wiring Entry (both sides)
NB3	28.58 mm Brazing Connection
NB4	53.98 mm Brazing Connection
NB5	2 1/2" Joint Connection
NB6	76.1 mm Welded Connection
NB7	Joint or Welded Connection

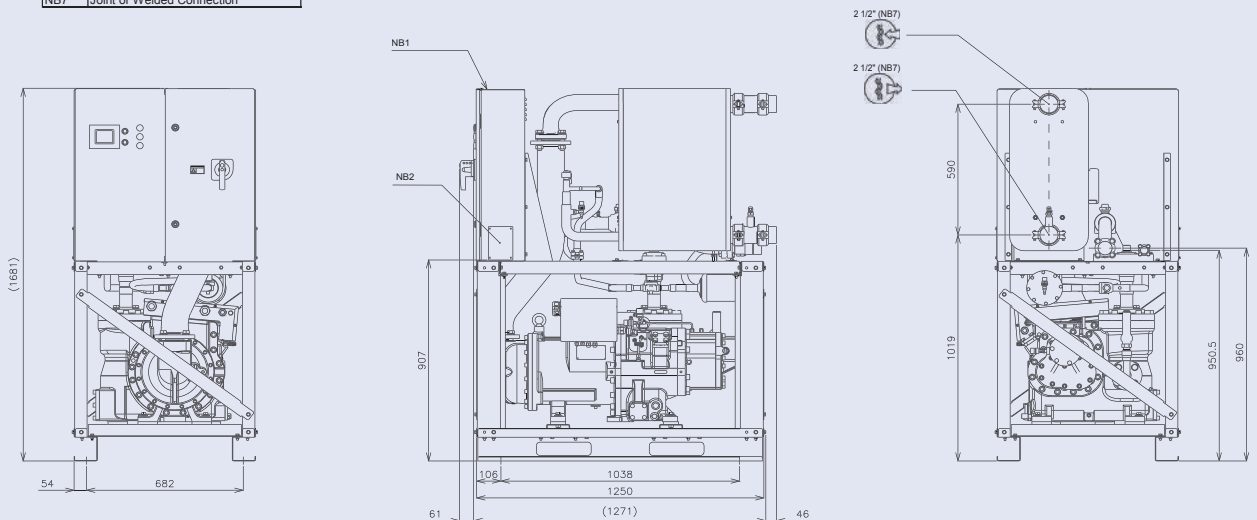

All dimensions in mm. Drawings not a scale.



Manufacturer reserves the rights to change specifications without prior notice.

YCWL / YCRL

Water-cooled or remote air-cooled scroll compressor chiller

Cooling capacities from 178 kW to 596 kW

Available configurations that meet A Class energy efficiency levels at Eurovent Standard Conditions.

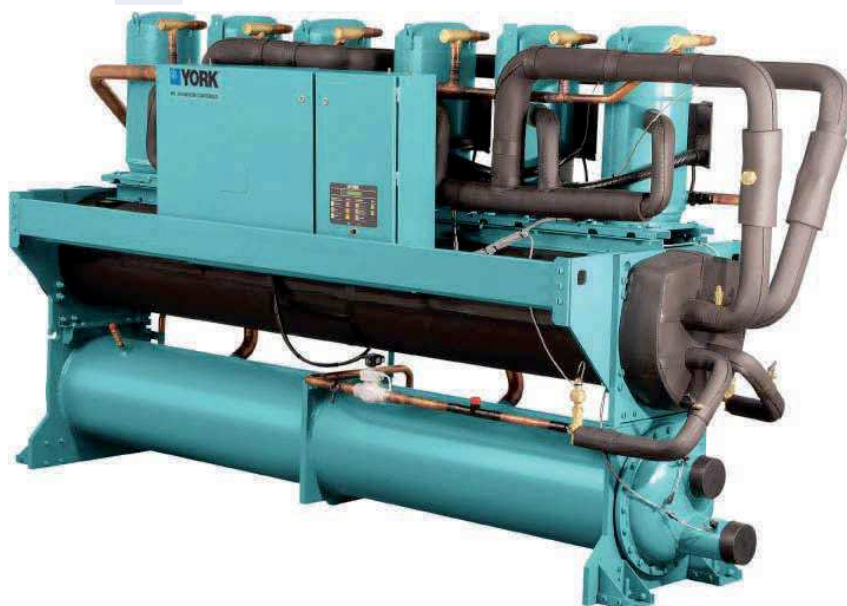

Features

The **YCWL** series was designed to produce the greatest cooling capacity with the lowest sound levels. The use of scroll compressors provides optimum efficiency at part load, up to an ESEER of 7.25. Its dimensions have been optimized to pass through a doorway 2 m high by 90 cm wide.

The **YCWL** is designed for all air conditioning applications. It is equipped with two independent cooling circuits and regulated by a micro-processor that optimizes chiller performance.

The **YCWL** is designed for indoor installation and each **YCWL** is fully tested before leaving our factories.

Options

- Leaving Chilled Liquid from -12 to +15°C
- Leaving Condenser Liquid from +18 to +50°C
- Compressor acoustic blankets
- Flow switch or pressure differential switch
- Soft starters
- Neoprene pads or spring isolators
- Dual relief valves kit
- Electronic regulators
- Vibration isolators

Water-cooled or remote air-cooled scroll compressor chiller

YCWL / YCRL 0200 to 0611



Nominal capacity

YCWL-SE	0241	0292	0343	0396
Cooling capacity (kW) ¹	223	294	334	371
EER ¹	4.38	4.72	4.69	4.71
Energy class ¹	C	B	B	B
ESEER ¹	6.34	6.48	6.59	6.49
Sound Pressure (dB(A)) ²	72	72	74	76

YCWL-HE	0201	0231	0261	0302	0347	0386	0426	0447	0532	0611
Cooling capacity (kW) ¹	191	219	244	308	353	391	411	444	498	595
EER ¹	4.94	4.92	5.03	4.95	5.00	5.12	5.07	4.98	5.01	4.90
Energy class ¹	B	B	B	B	B	A	A	B	B	B
ESEER ¹	5.97	6.33	7.25	6.79	6.54	7.09	6.70	6.28	6.80	6.57
Sound Pressure (dB(A)) ²	68	70	72	72	74	74	76	74	71	72

YCRL-HE	0200	0230	0260	0300	0345	0385	0445	0530	0610
Cooling capacity (kW) ³	178	207	233	273	325	356	415	485	556
EER ³	4.00	4.00	4.12	4.20	4.16	4.11	4.17	4.06	3.99
Sound Pressure (dB(A)) ²	64	65	67	67	70	68	69	71	73

1: Cooling capacity and efficiencies @ Eurovent conditions evaporator entering/leaving temperature 12C/7C condenser entering/leaving temperature 30/35C EN14511:2011.

2: EN 292-1991 Sound pressure is measured 1 meter away from the control panel and 1.5 meters above the floor.

3: Cooling capacity and efficiencies @ Eurovent conditions evaporator entering/leaving temperature 12C/7C saturated discharge temperature 45C EN14511:2007.

Technical data

YCWL-SE			0241	0292	0343	0396
Dimensions	Length	mm	3193	3161	3169	3159
	Width	mm	859			
	Height	mm	1752	1830	1819	
Operating weight	kg	2085	2481	2494	2716	

YCWL-HE			0201	0231	0261	0302	0347	0386	0426	0447	0532	0611
Dimensions	Length	mm	3161	3098	3154	3169	3132	3704	3133	3643		
	Width	mm	859	857	844	859		885	859	885		
	Height	mm	1670	1914	1820	1819	1889	1974	1889	1946	1965	
Operating weight	kg	2218	2512	2463	2481	2808	3343	2824	3632	3838	3999	

YCRL-HE			0200	0230	0260	0300	0345	0385	0445	0530	0610
Dimensions	Length	mm	3086	3061	3076		3061	3617	3576		
	Width	mm	826	856	843		856	965			902
	Height	mm	1438	1481	1471	1593	1683	1641	1638	1641	
Operating weight	kg	1309	1481	1471	1593	1682	1947	2266	2264	2263	



Manufacturer reserves the rights to change specifications without prior notice.

Dimensions and hydraulic connections

YCWL0241SE, YCWL0292SE, YCWL0343SE, YCWL0396SE, YCWL0201HE, YCWL0231HE, YCWL0261HE, YCWL0302HE, YCWL0347HE, YCWL0426HE, YCWL0447HE

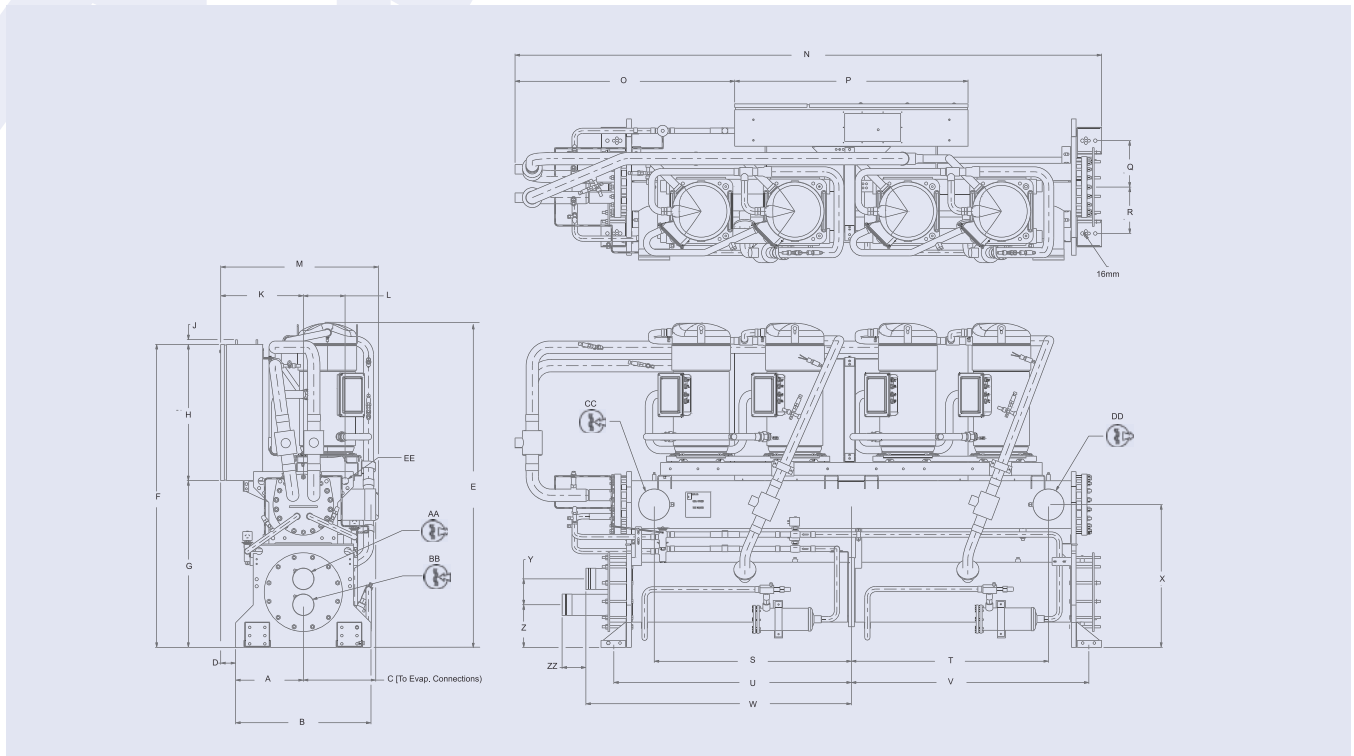

YCWL	0241SE	0292SE	0343SE	0396SE	0201HE	0231HE	0261HE	0302HE	0347HE	0426HE	0447HE
Dimension	mm	mm	mm	mm	mm	mm	mm	mm	mm	mm	mm
A	368	368	368	368	368	368	368	368	368	368	381
B	737	737	737	737	737	737	737	737	737	737	762
C	394	299	394	394	299	407	394	394	406	406	406
D	81	81	81	81	81	81	81	81	81	81	69
E	1752	1830	1819	1819	1670	1914	1820	1819	1889	1889	1946
F	1638	1638	1714	1714	1638	1753	1714	1714	1753	1753	1778
G	901	901	977	978	901	1016	977	977	1016	1016	1041
H	737	737	737	737	737	737	737	737	737	737	737
J	25	25	25	25	25	25	25	25	25	25	25
K	450	450	450	450	311	450	450	450	450	450	450
L	227	311	311	311	311	324	311	311	324	324	452
M	859	859	859	859	859	857	844	859	859	859	885
N	3194	3161	3169	3159	3161	3098	3154	3169	3132	3133	3643
O	1196	1163	1171	1155	1163	1100	1156	1171	1134	1133	1334
P	1270	1270	1270	1270	1270	1270	1270	1270	1270	1270	1270
Q	251	251	251	251	251	251	251	251	251	251	264
R	251	251	251	251	251	251	251	251	251	251	264
S	1073	1080	1080	1080	1080	1054	1080	1080	1054	1054	1295
T	1073	1080	1080	1080	1080	1054	1080	1080	1054	1054	1295
U	1293	1293	1293	1293	1293	1293	1293	1293	1293	1293	1598
V	1293	1293	1293	1293	1293	1293	1293	1293	1293	1293	1598
W	1445	1445	1445	1455	1445	1445	1445	1445	1455	1455	1774
X	772	813	813	813	813	845	813	813	845	845	921
Y	140	181	181	207	181	181	181	181	207	207	219
Z	230	210	210	197	210	210	210	210	197	197	216
ZZ	130	130	130	133	130	130	130	130	133	133	132
EE Ø	38	38	38	38	38	38	38	38	38	38	51

All dimensions in mm. Drawings not a scale.

YCWL	0241SE	0292SE	0343SE	0396SE	0201HE	0231HE	0261HE	0302HE	0347HE	0426HE	0447HE
Water Connections	in	in	in	in	in	in	in	in	in	in	in
AA Ø	4	4	4	5	4	4	4	4	5	5	5
BB Ø	4	4	4	5	4	4	4	4	5	5	5
CC Ø	6	6	6	6	6	8	6	6	8	8	8
DD Ø	6	6	6	6	6	8	6	6	8	8	8

Dimensions and hydraulic connections

YCWL0386HE, YCWL0532HE

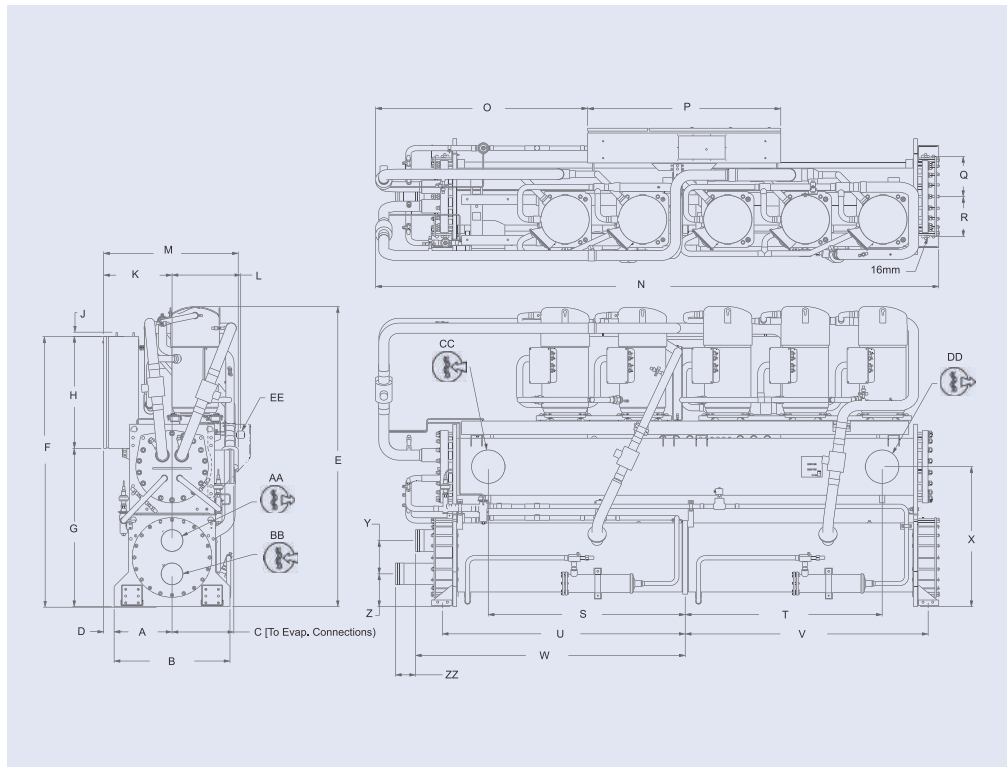

YCWL	0386HE	0532HE
Dimension	mm	mm
A	381	381
B	762	762
C	406	406
D	69	69
E	1974	1965
F	1778	1778
G	1041	1041
H	737	737
J	25	25
K	450	450
L	452	452
M	885	885
N	3704	3643
O	1395	1334
P	1270	1270
Q	263	263
R	263	263
S	1295	1295
T	1295	1295
U	1598	1598
V	1598	1598
W	1774	1774
X	921	921
Y	219	219
Z	216	216
ZZ	132	132
EE Ø	51	51

All dimensions in mm.

YCWL	0386HE	0532HE
Water Connections	in	in
AA Ø	5	5
BB Ø	5	5
CC Ø	8	8
DD Ø	8	8

YCWL0532HE

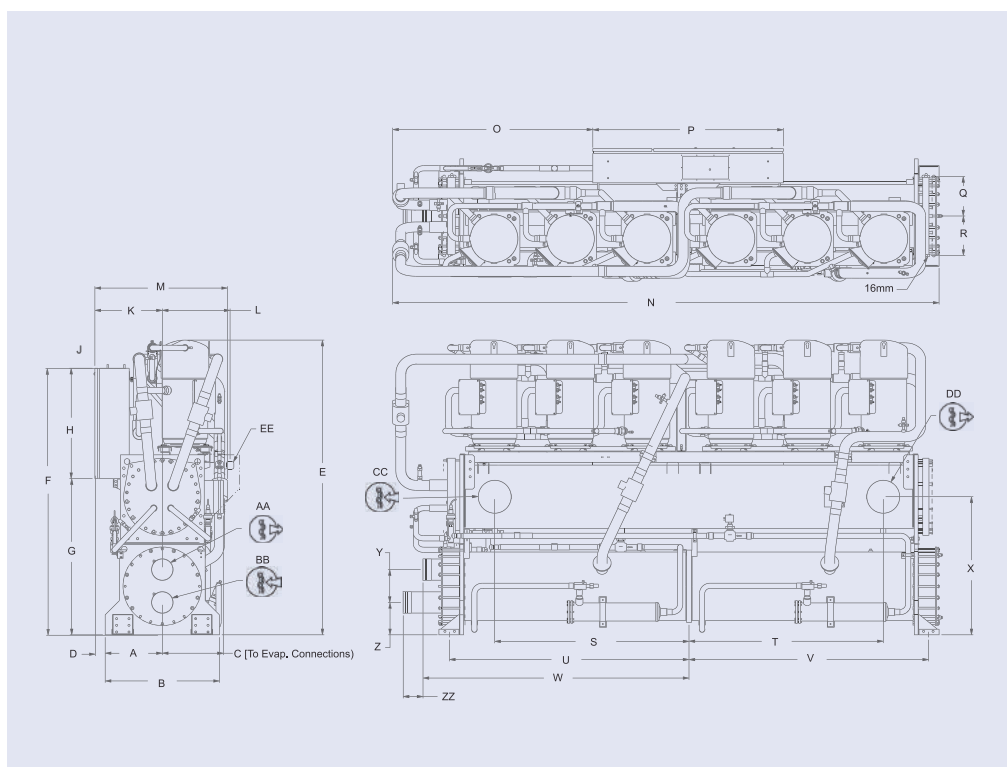

YCWL	0611HE
Dimension	mm
A	381
B	762
C	406
D	69
E	1965
F	1778
G	1041
H	737
J	25
K	450
L	452
M	885
N	3643
O	1334
P	1270
Q	264
R	264
S	1295
T	1295
U	1598
V	1598
W	1774
X	921
Y	219
Z	216
ZZ	132
EE Ø	51

All dimensions in mm.

YCWL	0532HE
Water Connections	in
AA Ø	5
BB Ø	5
CC Ø	8
DD Ø	8

Dimensions and hydraulic connections

YCRL 0200 HE to YCRL 0345 HE

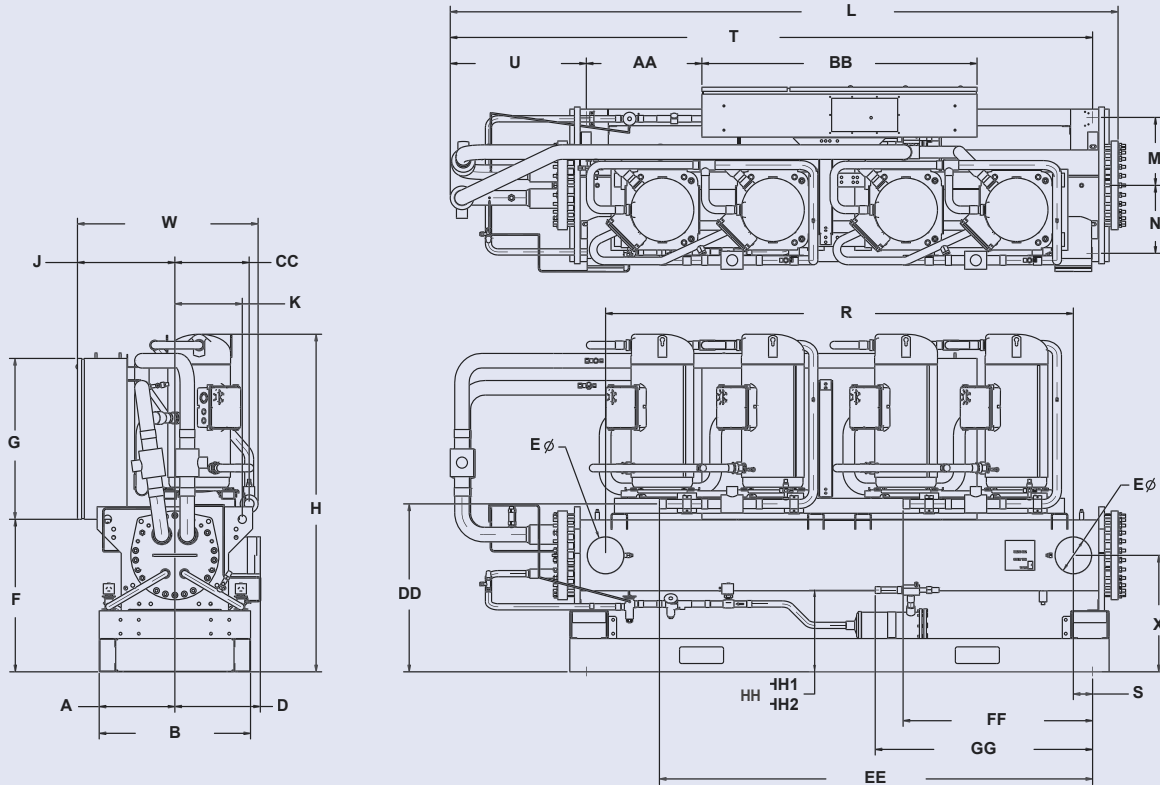

YCRL	0200 HE	0230 HE	0260 HE	0300 HE	0345 HE
W	824	834	834	834	846
H	1437	1616	1546	1544	1613
L	3085	3062	3082	3082	3062
A	349	349	349	349	349
B	699	692	699	699	699
D	299	407	394	394	407
E	219	219	168	168	219
F	622	737	699	699	737
G	737	737	737	737	737
J	450	450	450	450	450
K	311	324	311	311	324
M	311	311	311	311	311
N	311	311	311	311	311
R	2159	2108	2159	2159	2108
S	89	114	89	89	114
T	2965	2938	2965	2965	2938
U	628	601	628	628	601
X	533	565	533	533	565
AA	533	533	533	533	533
BB	1270	1270	1270	1270	1270
CC	343	343	343	343	356
DD	780	838	769	769	838
EE	2059	2085	1999	1999	2008
FF	947	886	875	875	883
GG	1003	1003	1003	965	1040
HH	466	375	375	375	378

All dimensions in mm. Drawings not a scale.

Dimensions and hydraulic connections

YCRL 0385 HE to YCRL 0610 HE

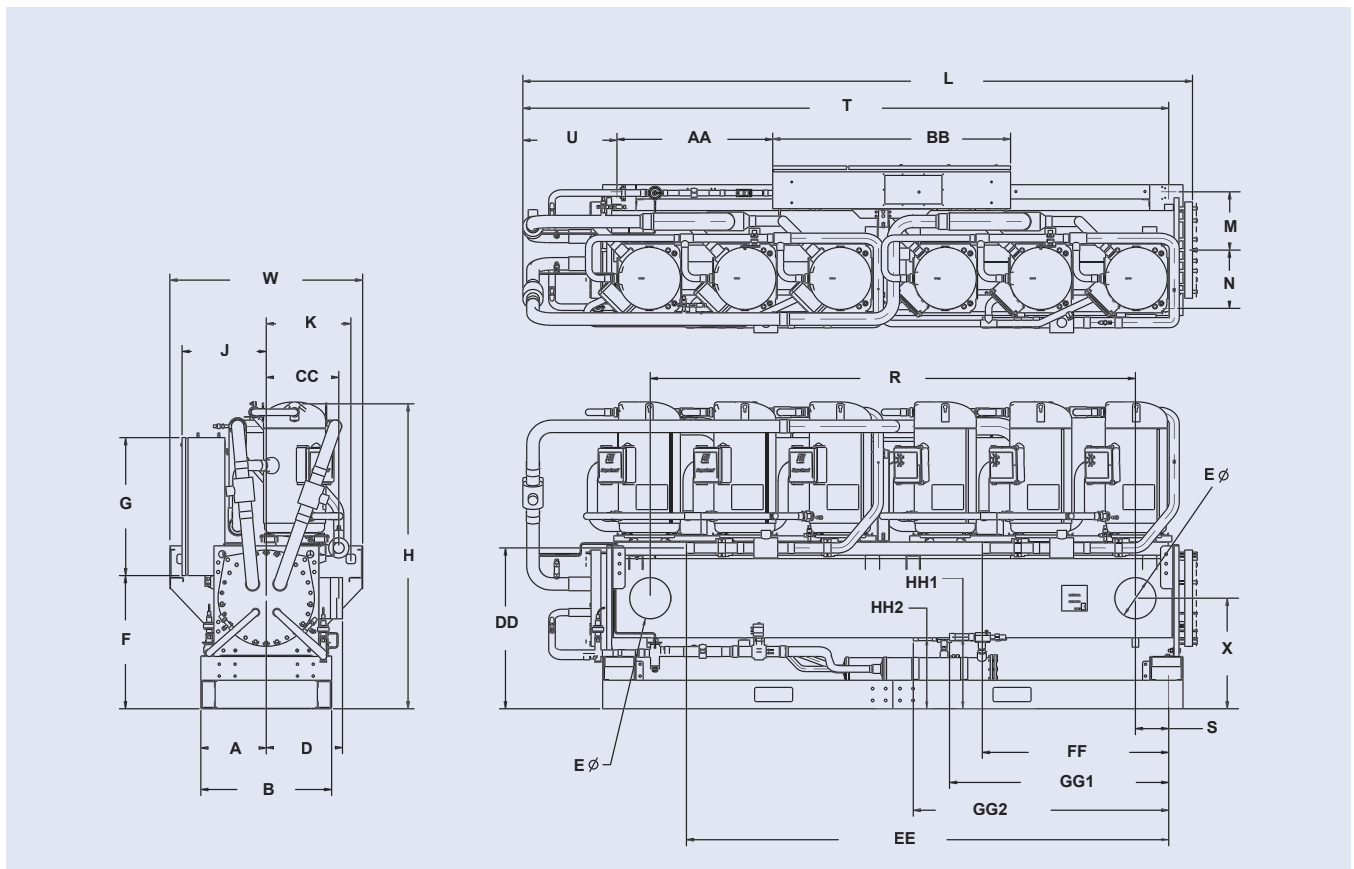

YCRL	0385 HE	0445 HE	0530 HE	0610 HE
W	1030	1030	965	902
H	1641	1628	1641	1641
L	3633	3576	3576	3576
A	349	349	349	349
B	699	692	699	699
D	406	407	407	407
E	219	219	219	219
F	711	711	711	711
G	737	737	737	737
J	450	450	450	450
K	452	452	452	452
M	311	311	311	311
N	311	311	311	311
R	2591	2591	2591	2591
S	178	178	178	178
T	3509	3449	3449	3449
U	563	502	502	502
X	591	591	592	587
AA	832	832	832	832
BB	1270	1270	1270	1270
CC	387	387	387	387
DD	859	859	859	859
EE	2499	2575	2575	2575
FF	919	995	995	995
GG-1	1466	1171	1171	1171
GG-2	1466	1364	1364	1364
HH-1	378	383	383	383
HH-2	378	379	379	379

All dimensions in mm. Drawings not a scale.

YLCS

Water-cooled or remote air-cooled screw compressor chiller Heat pump application

Cooling capacities from 342 kW to 1099 kW

Available configurations that meet A Class energy efficiency levels at Eurovent Standard Conditions.



Features

One chiller, many applications

Designed to operate with leaving liquid temperature from -12°C to $+15^{\circ}\text{C}$.

Efficient compressors

YLCS is a dual circuit chiller with industrial type semi-hermetic screw compressors. Star delta compressor starters are incorporated to reduce the inrush current.

Outstanding chiller control

An advanced microprocessor controller with, a 40 character plain language display, controls and monitors temperatures, pressures, operating hours, number of starts and start stop/holiday times.

Fast and easy installation

Evaporator water connections can be provided in a vertical or horizontal plain. Electrical power supplies enter from the top for easy drop down wiring.

Options / Accessories

- Compressor suction shut-off valves
- Companion flange kits
- Multi-point power supply
- Remote leaving liquid temperature offset
- Pressure gauges
- Closed transition star delta starters
- Power factor correction capacitors
- Heat pump control up to 60°C
- 90/10 cupro/nickel condenser

Water-cooled or remote air-cooled screw compressor chiller

YLCS 0350 to 1120



Nominal capacity

YLCS	0350	0415	0480	0530	0575	0620
Cooling capacity (kW)	343.5	406	482.6	512.6	552.8	586.8
EER	4.01	4.1	4.14	4.16	4.14	4.14
ESEER	4.41	4.63	4.68	4.76	4.67	4.75
Sound pressure at 1 m (dBA)	74	74	74	77	76	76

YLCS	0670	0750	0860	0980	1120
Cooling capacity (kW)	644	744.3	867.3	979.9	1122
EER	4.53	4.61	4.73	4.72	4.72
ESEER	5.05	5.17	5.17	5.12	5.06
Sound pressure at 1 m (dBA)	76	76	82	82	82

At 7°C leaving chilled water and 35°C leaving condenser water.

Technical data

YLCS			0350	0415	0480	0530	0575	0620
Dimensions	Length	mm	3225	3244	3274		3544	3600
	Width	mm	900					
	Height	mm	2100					
Operating weight kg			3420	4030	4170	4270	4370	4540

YLCS			0670	0750	0860	0980	1120
Dimensions	Length	mm	3565	3645	3830	3830	3830
	Width	mm	1290				
	Height	mm	2148				
Operating weight kg			4510	5010	5620	6090	6610



Manufacturer reserves the rights to change specifications without prior notice.

Dimensions and hydraulic connections

YLCS 0350SA/HA to 0620SA/HA

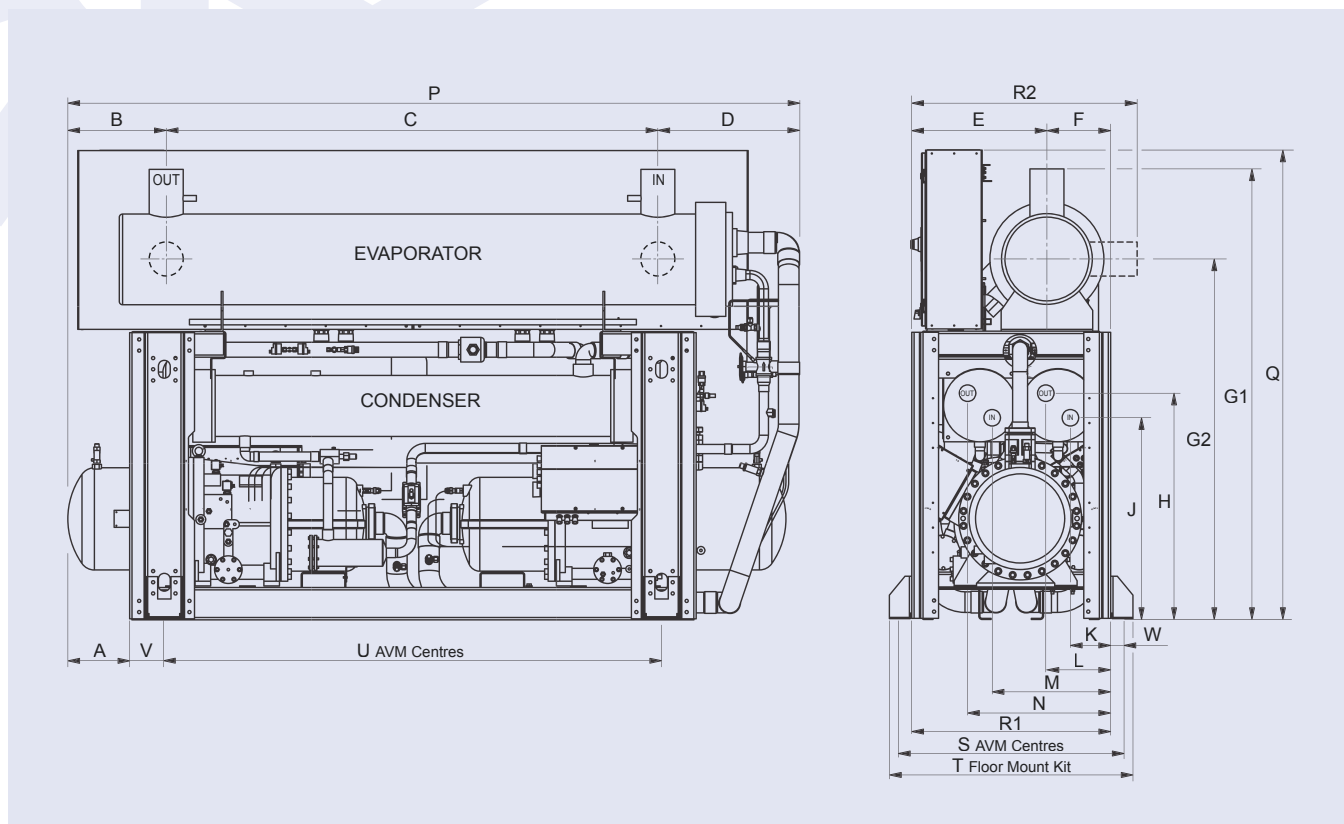

Model	A	B	C	D	E	F	G1 ⁽¹⁾	G2 ⁽²⁾	H	J	K	L	M	N	P	Q	R1	R2 ⁽²⁾	S	T	U	V	W
350-SA & 350-HA	247	417	2250	558	605	285	1914	1550	1033	963	200	270	550	620	3225	2100	890	967	1010	1090	2225	155	60
415-SA & 415-HA	247	417	2250	558	605	285	1915	1550	1013	903	180	290	530	640	3244	2100	890	967	1010	1090	2225	155	60
480-SA & 480-HA	277	440	2200	634	605	285	2016	1615	1013	903	180	290	530	640	3274	2100	890	1010	1010	1090	2225	155	60
530-SA & 530-HA	277	440	2200	634	605	285	2016	1615	1013	903	180	290	530	640	3274	2100	890	1010	1010	1090	2225	155	60
575-SA & 575-HA	550	210	2700	634	605	285	2016	1615	1013	903	180	290	530	640	3544	2100	890	1010	1010	1090	2225	155	60
620-SA & 620-HA	550	210	2700	690	605	285	2016	1615	1013	903	180	290	530	640	3600	2100	890	1010	1010	1090	2225	155	60

All dimensions in mm. Drawings not a scale.

Dimensions exclude insulation and options. Refer to Physical Data Section for connection sizes. For reference only, please refer to York Product drawing for complete drawing.

(1) With Vertical nozzle cooler only. (2) With horizontal nozzle cooler only.

Dimensions and hydraulic connections

YLCS 0350AA to 0620AA

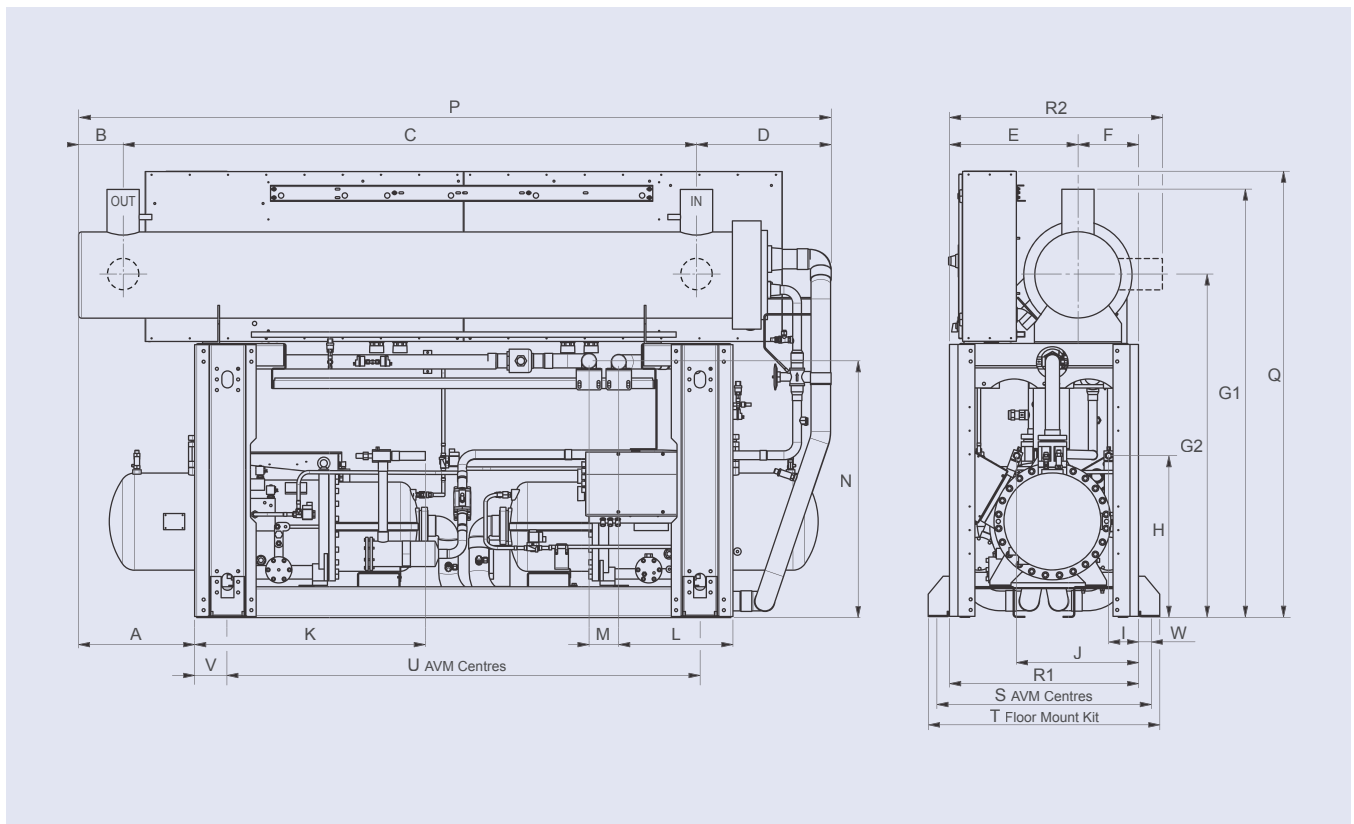

Model	A	B	C	D	E	F	G1 ⁽¹⁾	G2 ⁽¹⁾	H	I	J	K	L	M	N	P	Q	R1	R2 ⁽²⁾	S	T	U	V	W
350-AA	247	417	2250	558	605	285	1914	1550	761	140	573	1032	538	140	1200	3225	2100	890	967	1010	1090	2225	155	60
415-AA	247	411	2250	583	605	285	1915	1550	761	140	573	1032	538	140	1204	3244	2100	890	967	1010	1090	2225	155	60
480-AA	277	440	2200	634	605	285	2016	1615	761	140	573	1087	538	140	1204	3274	2100	890	1010	1010	1090	2225	155	60
530-AA	277	440	2200	634	605	285	2016	1615	761	140	573	1087	538	140	1200	3274	2100	890	1010	1010	1090	2225	155	60
575-AA	550	210	2700	634	605	285	2016	1615	761	140	573	1087	538	140	1204	3544	2100	890	1010	1010	1090	2225	155	60
620-AA	550	210	2700	690	605	285	2016	1615	761	140	573	1087	538	140	1204	3600	2100	890	1010	1010	1090	2225	155	60

All dimensions in mm. Drawings not a scale.
 Dimensions exclude insulation and options. Refer to Physical Data Section for connection sizes. For reference only, please refer to York Product drawing for complete drawing.
 (1) With Vertical nozzle cooler only. (2) With horizontal nozzle cooler only.

Dimensions and hydraulic connections

YLCS 0670SA/HA - 0750SA/HA

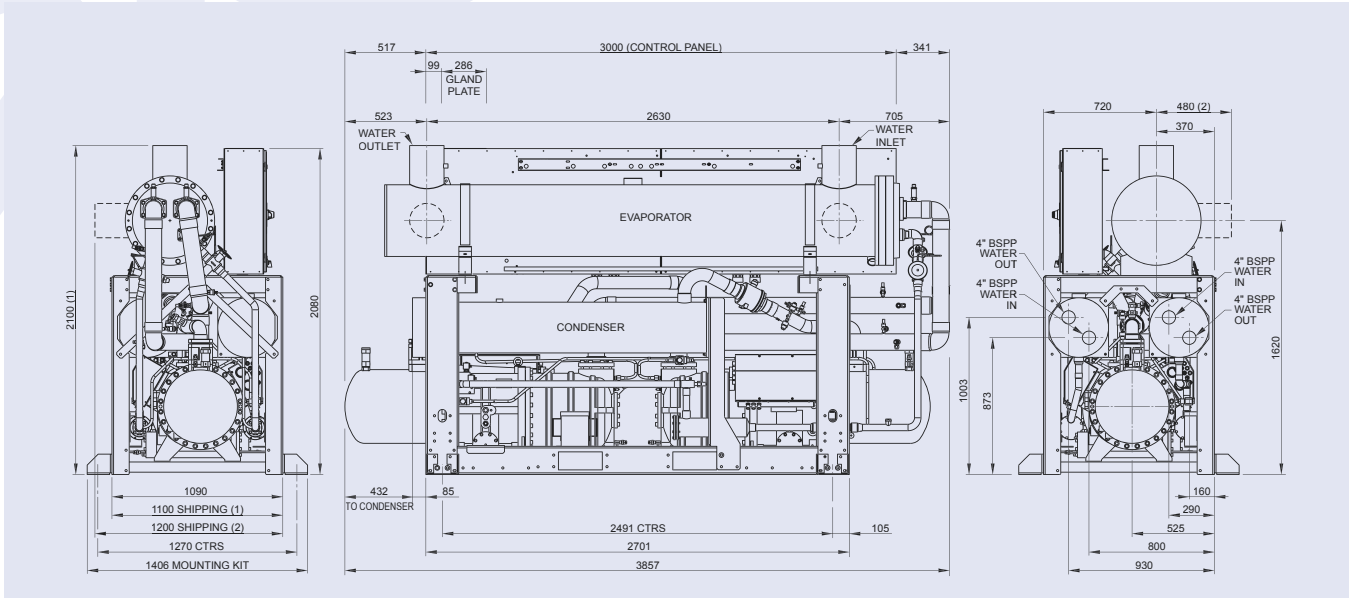

All dimensions in mm. Drawings not a scale.
 Dimensions exclude insulation and options. Refer to Physical Data Section for connection sizes. For reference only, please refer to York Product drawing for complete drawing.
 (1) With Vertical nozzle cooler only. (2) With horizontal nozzle cooler only.

YLCS 0860SA/HA to 1120SA/HA

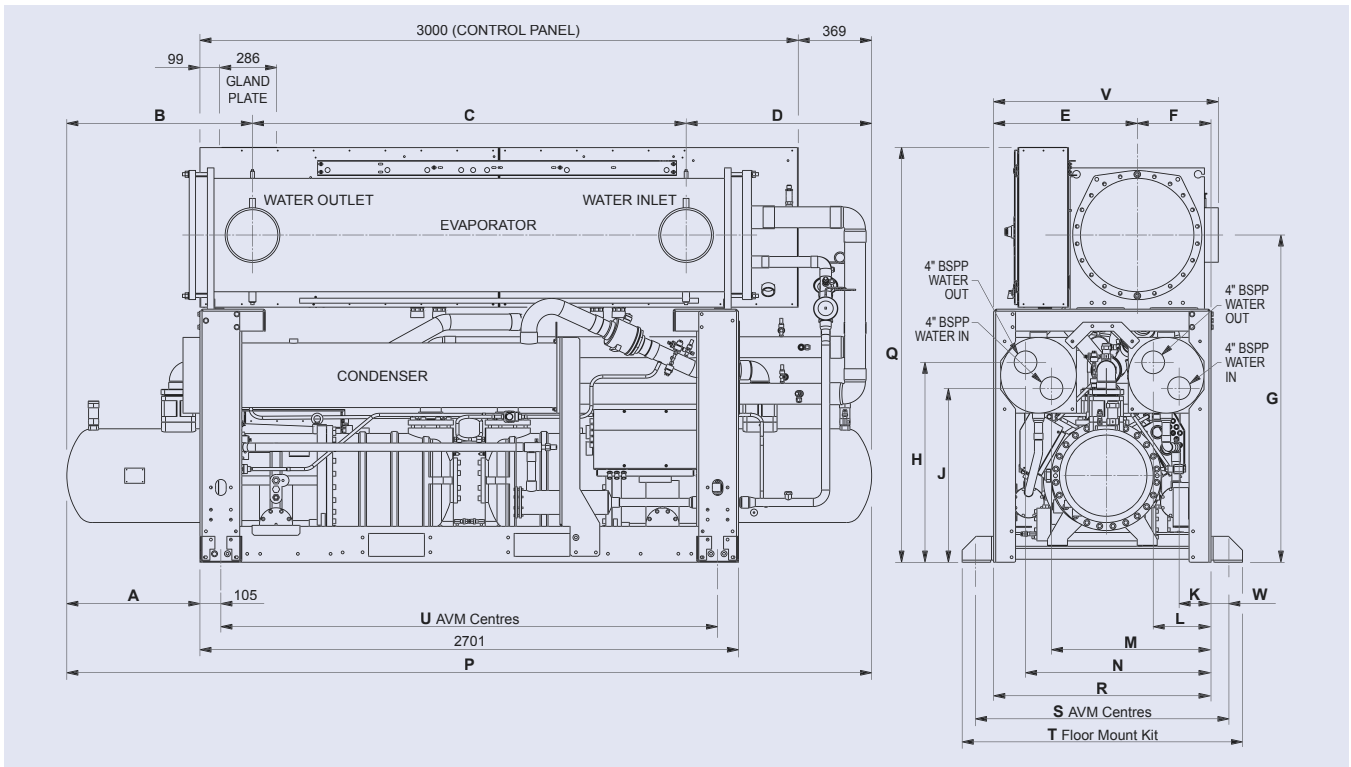

Model	A	B	C	D	E	F	G	H	J	K	L	M	N	P	Q	R	S	T	U	V	W
860-SA & 860-HA	517	780	2175	930	720	370	1641	1003	873	160	290	800	930	3885	2080	1090	1270	1406	2491	1136	90
980-SA & 980-HA	668	930	2175	930	720	370	1641	1003	873	160	290	800	930	4036	2080	1090	1270	1406	2491	1126	90
1120-SA & 1120-HA	668	1025	2010	1000	835	455	1721	1045	915	211	341	950	1080	4036	2144	1290	1470	1606	2491	1295	90

All dimensions in mm. Drawings not a scale.
 Dimensions exclude insulation and options. Refer to Physical Data Section for connection sizes. For reference only, please refer to York Product drawing for complete drawing.

Dimensions and hydraulic connections

YLCS 0670AA - 0750AA

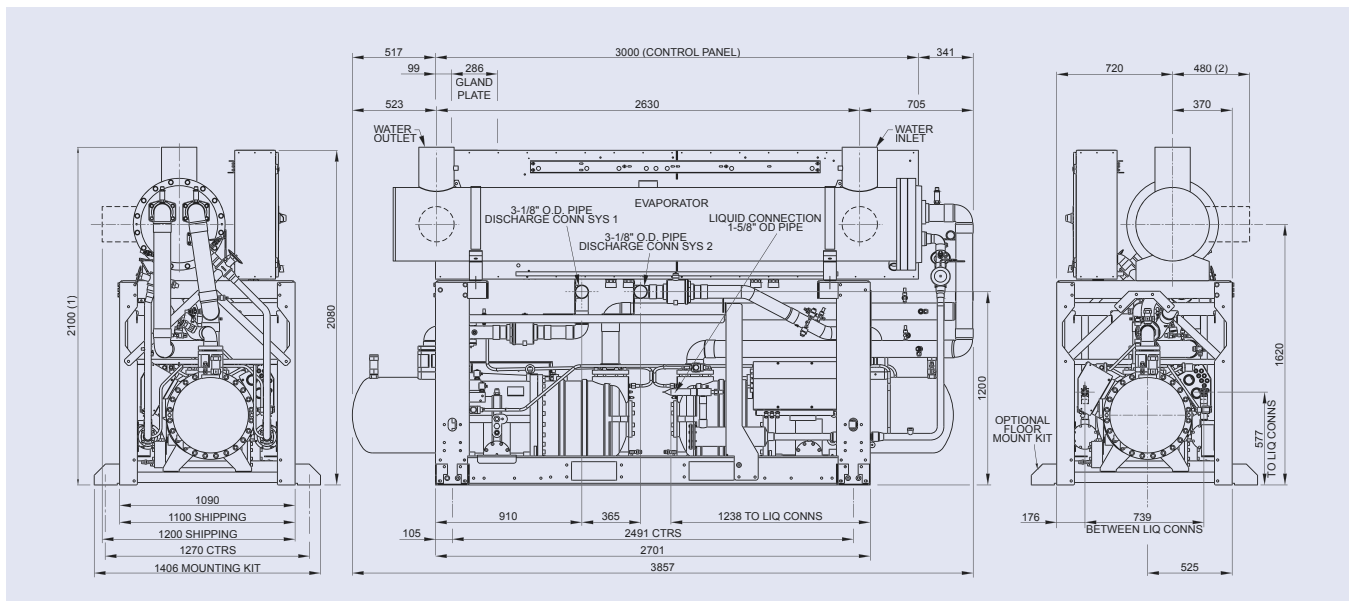

All dimensions in mm. Drawings not a scale.
 Dimensions exclude insulation and options. Refer to Physical Data Section for connection sizes. For reference only, please refer to York Product drawing for complete drawing.
 (1) With Vertical nozzle cooler only. (2) With horizontal nozzle cooler only.

YLCS 0860AA to 1120AA

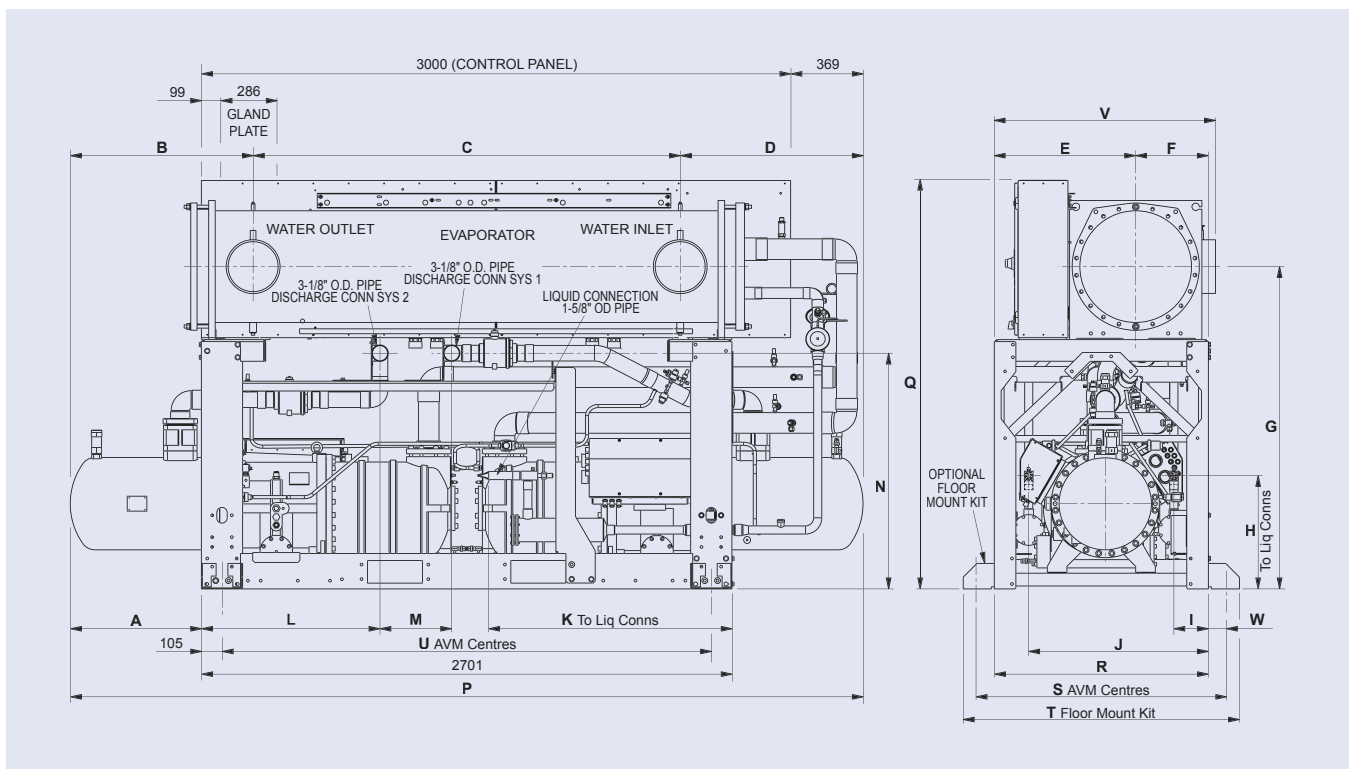

Model	A	B	C	D	E	F	G	H	I	J	K	L	M	N	P	Q	R	S	T	U	V	W
860-AA	517	780	2175	930	720	370	1641	577	175	915	1238	910	365	1200	3885	2080	1090	1270	1406	2491	1136	90
980-AA	668	930	2175	930	720	370	1641	577	175	915	1238	910	365	1200	4036	2080	1090	1270	1406	2491	1126	90
1120-AA	668	1025	2010	1000	835	455	1721	577	275	1015	1407	785	246	963	4036	2144	1290	1470	1606	2491	1295	90

All dimensions in mm. Drawings not a scale.
 Dimensions exclude insulation and options. Refer to Physical Data Section for connection sizes. For reference only, please refer to York Product drawing for complete drawing.

YVWA

Water-cooled variable speed screw chiller

Cooling capacities from 435 kW to 1055 kW

At Eurovent Standard Conditions this equipment meets A Class energy efficiency levels.



Features

Our newest water-cooled chiller offers the following benefits:

Premium efficiency

The YVWA reduces operating expenses with the application of a standard variable speed drive.

Application flexibility

Tailor and tune flexibility makes the YVWA ideal for any application from thermal storage to heat pump duty.

Enhanced sustainability

Achieved through high efficiency operation and low refrigerant charges.

Product confidence

Improve your peace of mind knowing our experience stands behind every chiller.

Options / Accessories

- BMS Interfacing options
- Different options of tubes and nozzle arrangements for the heat exchangers.
- Dual pressure relief valve
- Several options for flow switches
- Thermal insulation options
- Anti-vibration mounts options

Photo courtesy of the ITCM lab of the Ecole Polytechnique Fédérale de Lausanne, Switzerland

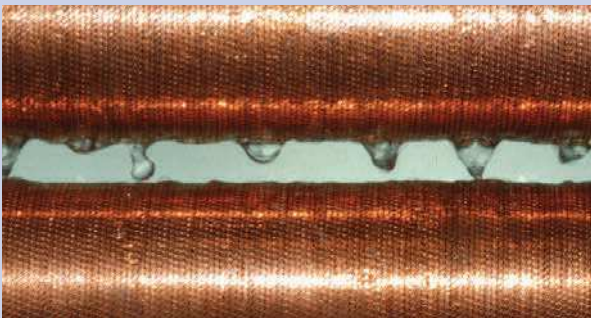

Reduce refrigerant charges by up to 15% beyond traditional chiller designs with the YVWA's falling film evaporator design.



The YVWA chiller can efficiently handle the high condenser pressure required for dry cooling.

Photo courtesy of Baltimore Air Coil.

Water-cooled variable speed screw chiller

YVWA



Nominal capacity

YVWA	BBBBFX	CDCDFX	BBBBGX	CD CDGX	M2MCEE	MBMCEE	MDMDFE	MEMEFF
Cooling capacity (kW)	435	500	575	650	700	800	900	1000
EER 100%	5.23	5.52	4.89	5.24	5.2	5.29	5.35	5.31
ESEER	6.8	7.08	6.73	7.06	6.72	6.79	6.88	6.98

Cooling Capacity at Eurovent Conditions, entering / leaving chilled water temperature 12 / 7 °C condenser water 30 / 35 °C
Capacities are rounded nominal values across the product range.

The taylor and tune models allow over 7000 component combinations in stepless selection capacities / operating conditions.
Specific selections may achieve an operating envelope of -10 to + 16 °C evaporator liquid and from 18 to 65 °C condenser liquid.
Models are using selected components from the quick ship program.

Technical data

YVWA	BBBBFX	CDCDFX	BBBBGX	CD CDGX	M2MCEE	MBMCEE	MDMDFE	MEMEFF
Compressors / Circuite(s)	1	1	1	1	2	2	2	2
Dimensions	Length	mm	3 002	3 612	3 002	3 612	4 223	
	Width	mm	1 413			1 405		
	Height	mm	1 846			1 824		
Operating weight (kg)	3 692	4 169	3 822	4 299	5 884	6 032	6 315	6 540
Refrigerant charge (kg)	127	153	137	163	250	250	255	260

YVWA Efficiency vs. Ordinary Chiller

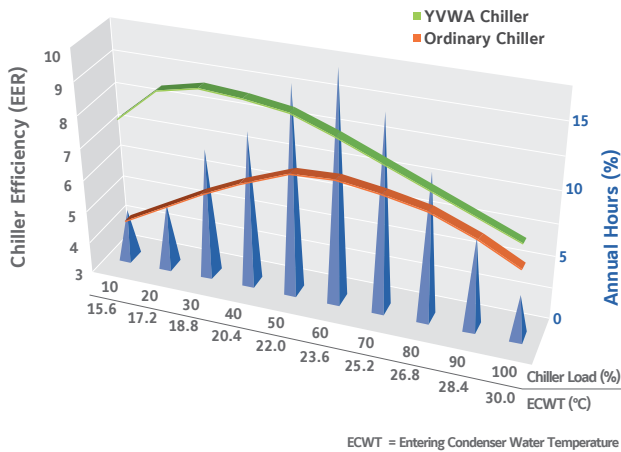

ECWT = Entering Condenser Water Temperature

The YVWA chiller delivers superior energy performance at all operating hours.

YVWA Energy Cost vs. Ordinary Chiller

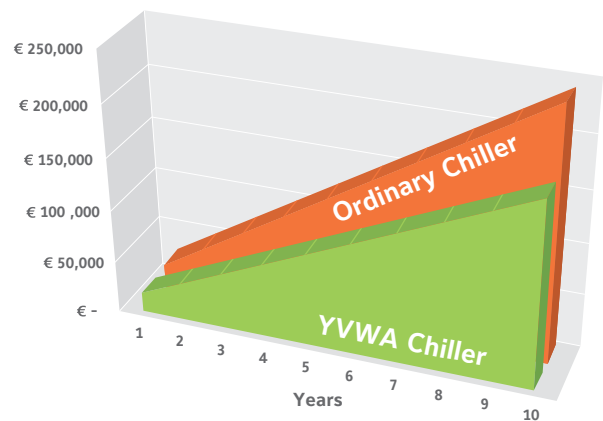

Note: 3,500 operating hours, 0.10 EUR/kWh energy rate, 800 kW design cooling load

An investment in an optimized YVWA chiller reduces energy costs by 25%.



Manufacturer reserves the rights to change specifications without prior notice.

Dimensions and hydraulic connections

YVWA B models

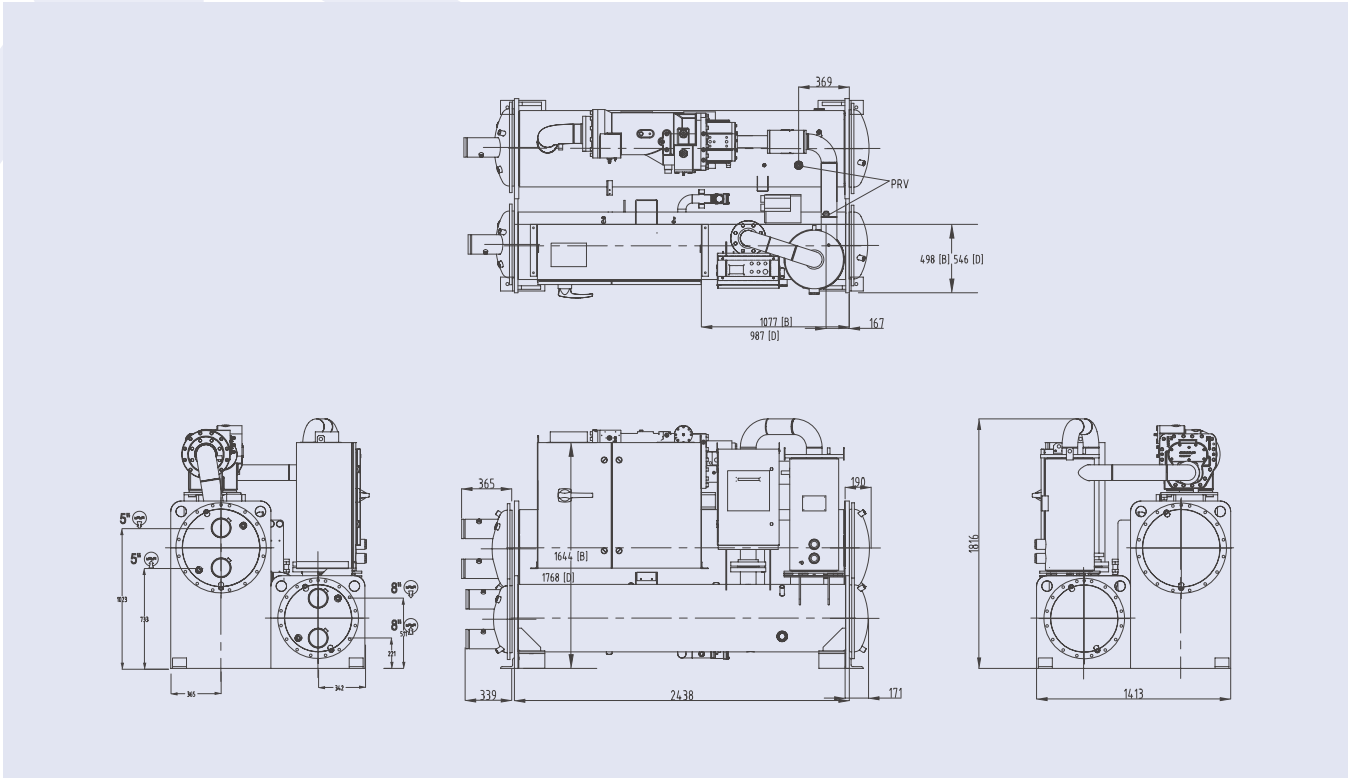

YVWA C models

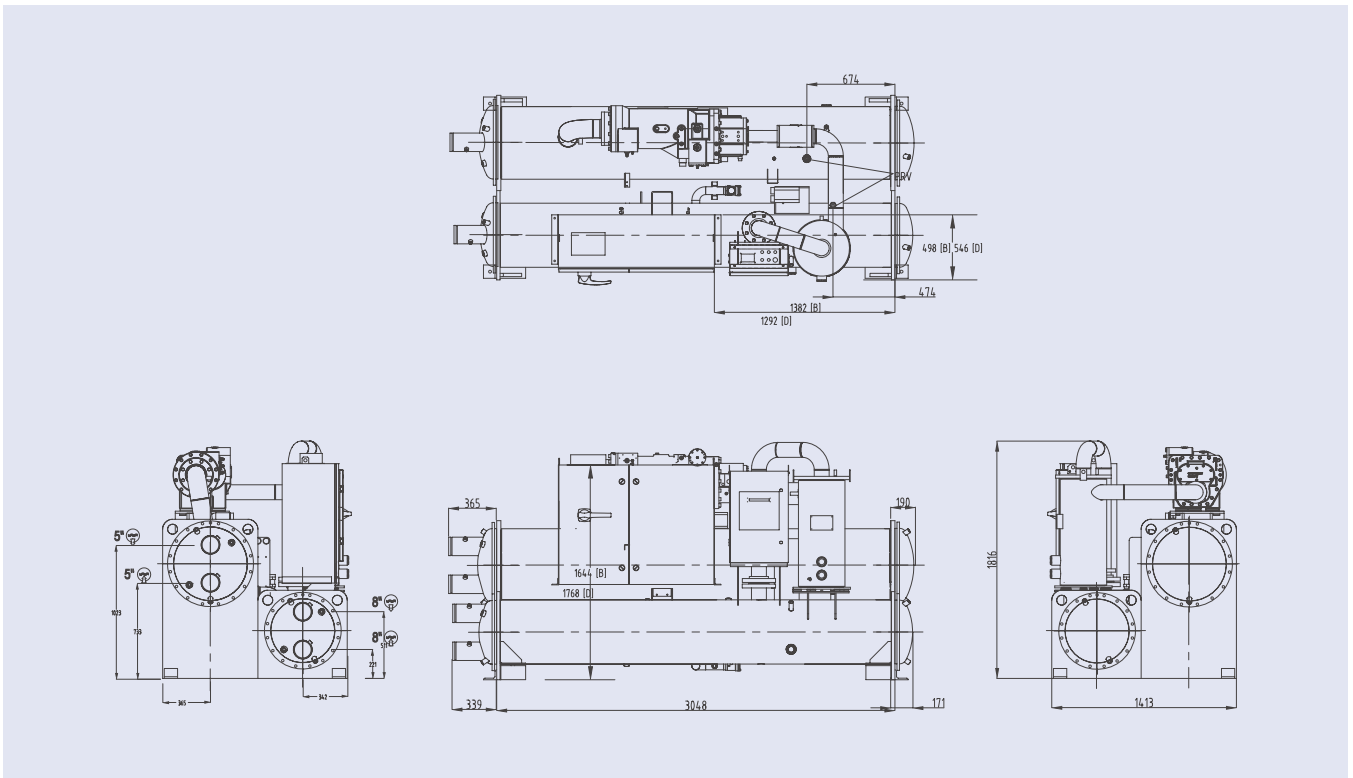

Dimensions and hydraulic connections

YVWA M models

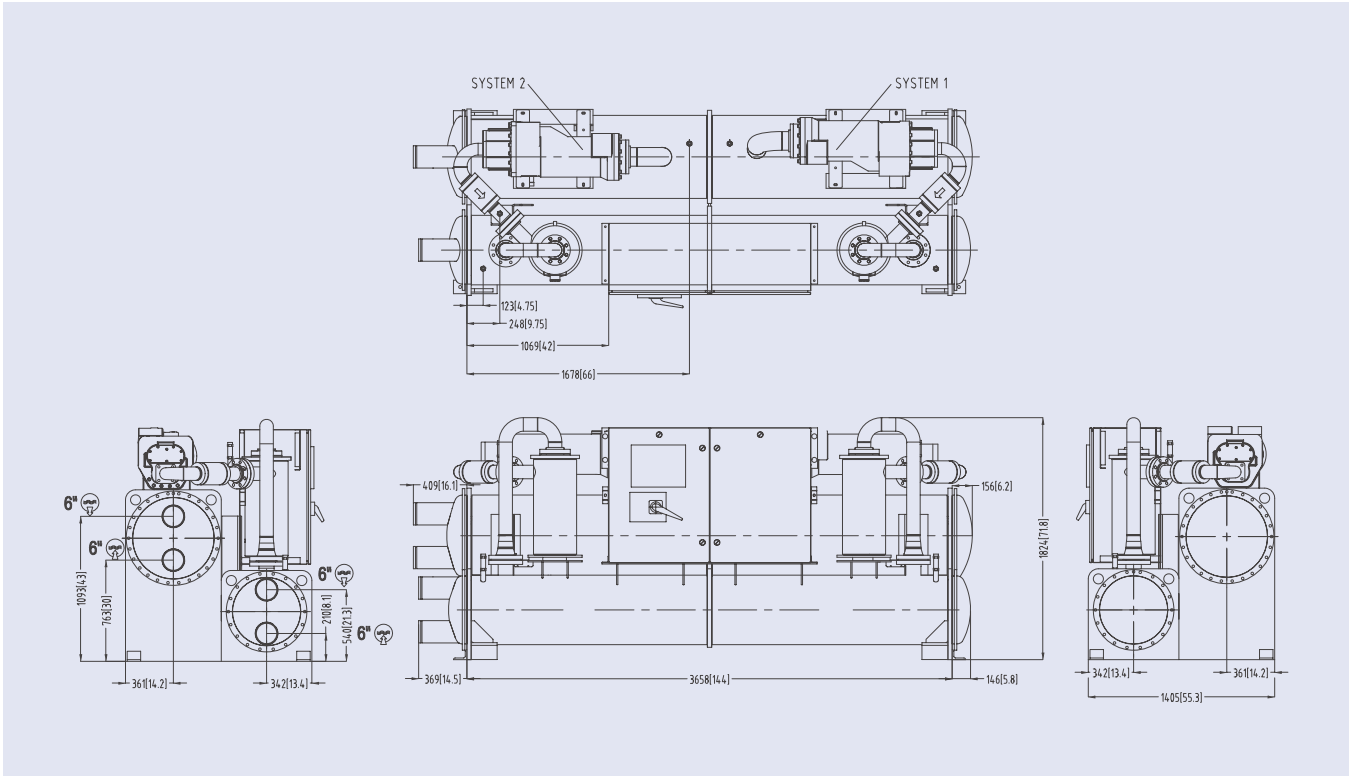

YVWA N models

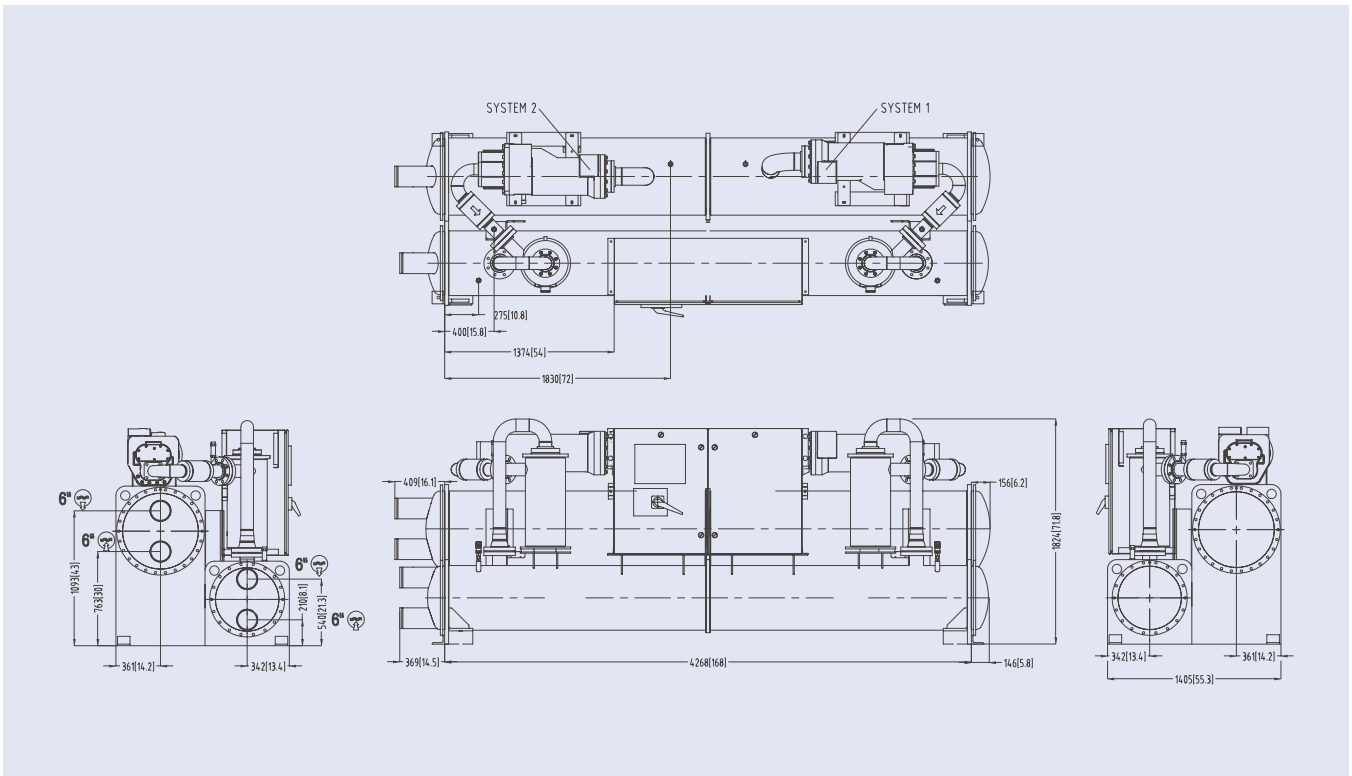

YMC² Water-cooled magnetic centrifugal chiller

Cooling capacities from 755 kW to 1970 kW

At Eurovent Standard Conditions this equipment meets A Class energy efficiency levels.



Features

Our most advanced water-cooled chiller offers the following benefits:

Enhanced efficiency

Achieved through application of active magnetic bearing technology with variable speed drive.

Enhanced sustainability

Achieved by leak free refrigerant design, lower refrigerant charge and falling film evaporator.

Low sound levels

Advanced technology results in sound levels as low as 73dBA.

Superior reliability

Use of active magnetic bearing technology removes friction and the need for oil resulting in a quieter and more reliable chiller.

Photo courtesy of the LTCM lab of the Ecole Polytechnique Fédérale de Lausanne, Switzerland

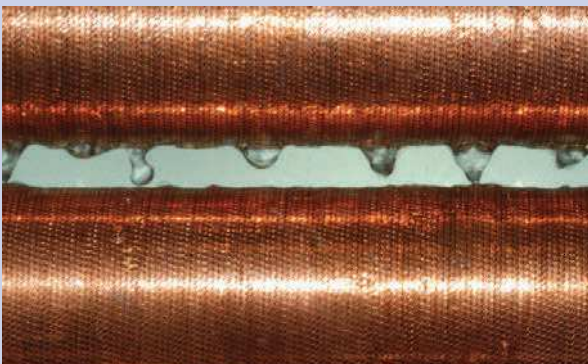

A falling-film evaporator is more efficient because refrigerant is sprayed over the tubes, offering improved heat transfer and reducing refrigerant charge by 30%.



To eliminate mechanical-contact losses in the driveline, the YMC2 chiller utilises a permanent-magnet motor and active magnetic-bearing technology.

Water-cooled magnetic centrifugal chiller

YMC² S0900AA to S1900AB



Nominal capacity (*)

YMC ²	S0900AA	S1000AA	S1100AA	S1200AA	S1300AB	S1400AB	S1500AB	S1600AB	S1700AB	S1800AB	S1900AB
Cooling capacity (kW)	900	1000	1100	1200	1300	1400	1500	1600	1700	1800	1900
EER	6.39	6.44	6.42	6.33	6.4	6.4	6.4	4.42	6.64	6.6	6.55
ESEER	8.32	8.83	9.15	9.40	9.42	9.5	9.7	9.83	10.2	10.3	10.5
Sound pressure at 1 m (dBA)	73	73	73	73	73	73	73	73	73	73	73

Cooling Capacity at Eurovent Conditions, entering/leaving chilled water temperature 12°C/7°C, entering/leaving condenser water temperature 30°C/35°C
 (*) YMC² is a tailor and tune chiller. Its performance will be factory-adjusted to match the exact site requirements based on the specific project operating

Technical data

YMC ²	S0900AA	S1000AA	S1100AA	S1200AA	S1300AB	S1400AB	S1500AB	S1600AB	S1700AB	S1800AB	S1900AB
Dimensions	Length	4267			3918	3943			5163		
	Width	1651			1791	2007					
	Height	2362			2118	2573					
Shipping weight (kg)	5340	5800	5810	5810	6579	7809	7809	7944	9442	9942	9942
Refrigerant charge (kg)	255	280	280	390	397	443	442	452	639	639	639

- NOTES:
1. All dimensions are approximate. Certified dimensions are available on request.
 2. Refrigerant charge quantity and shipping weights will vary based on tube count.
 3. Shipping weights are based on fully assembled and charged units.
 4. Refer to product drawings for detailed weight information.

Superior sound reduction

A-Weighted sound pressure level (dBA (re: 20µPa))
 Measured in accordance with AHRI-575

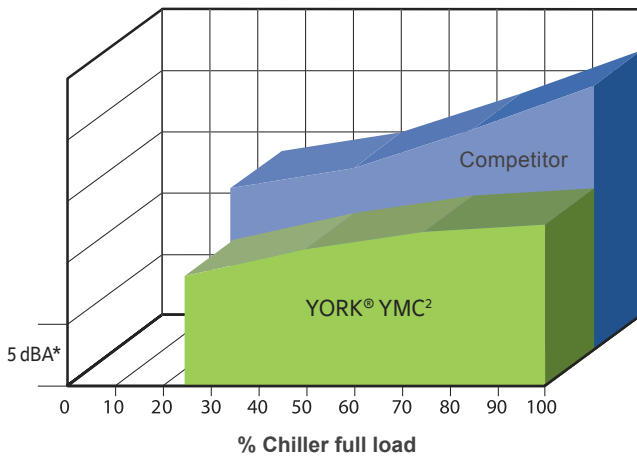

The YMC² chiller is so much quieter than competitive magnetic-bearing chillers, it sounds about half as loud. *Note: each segment on the Y axis = 5 dBA.

Compact design

Ideal for retrofits, additional YMC² 8 ft options (2.44 m) now available.

For more information please contact your Johnson Controls Sales representative.

OptiView control centre



The OptiView control centre provides complete diagnostics to speed troubleshooting.



Manufacturer reserves the rights to change specifications without prior notice.

YK Water-cooled centrifugal chiller

Cooling capacities from 800 kW to 11250 kW

Available configurations that meet A Class energy efficiency levels at Eurovent Standard Conditions.



Features

- The YORK YK chiller is designed for air conditioning and process applications.
- The high efficiency single-stage centrifugal compressor is powered by an open-drive motor. This provides flexibility to operate the chiller with electricity, steam, or gas depending on utility rates.
- The YK utilizes a falling film evaporator to increase chiller efficiency and reduce refrigerant charges, which makes it ideal for LEED® building applications.
- This chiller is designed for indoor mechanical room installation and it requires a cooling tower for heat dissipation
- The inherent design flexibility of this chiller allows it to be precisely selected for any building load profile.



OptiView panel

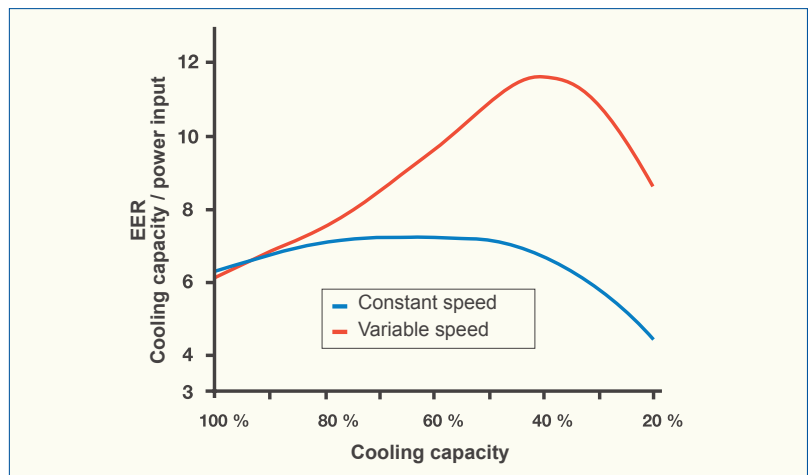

Speed comparison

Water-cooled centrifugal chiller

YK



Nominal capacity

Model	Code	Cooling capacity kW
YK	Q3 - Q7	800 - 2100
	P7 - P9	1750 - 2800
	H9	2400 - 3800
	K1 - K7	3200 - 9850
YK-EP	K7 & Q3	8800 - 11250

Cooling capacities at 7°C leaving chilled water and 30 °C entering condensed water.

Heat Recovery

The YK Heat Recovery option can be used for domestic hot water preheat, process heat, facility air reheat, and humidity control. Heat recovery delivers operational savings, CO2 reductions, and reduced water consumption.



Medium Voltage Variable Speed Drive

YORK has a full line of unit mounted and floor mounted Variable Speed Drives, from 380V to 11,000V, to maximize operational savings at off design conditions; which typically occur 99% of the time!



Quick Start (only available for VSD units)

Utilize Quick Start technology to improve chiller starting times and get back to setpoint up to 70% faster than standard chiller designs!

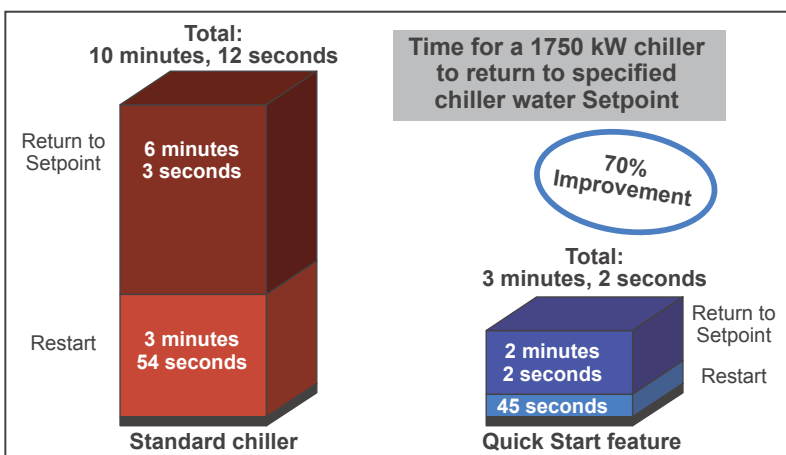

Manufacturer reserves the rights to change specifications without prior notice.

YHAU CL

Single stage hot water driven absorption chiller

Cooling capacities from 105 kW to 6153 kW



Features

Flexible Operating Envelope

The YORK YHAU-CL Single Effect Hot Water absorption chiller provides efficiency and reliability through the use of innovative technology that is optimized to use low temperature waste heat – as low as 70°C where competitive offerings cannot operate. Common applications include comfort or industrial process cooling that use or recover waste heat from combined heat and power (CHP) systems, industrial process or other available heat sources. The YHAU-CL cooling capacity ranges from 105-6,153 kW / 30-1,750 TR.

The YHAU-CL has the unique ability to be used for applications where the

- Chilled water leaving temperature as low as 4C.
- Cooling water temperature entering temperature as high as 37C.
- Hot water temperature, driving heat source, entering temperature as low as 70C.

Refrigerant cycle

The YORK YHAU CL high efficiency single-stage absorption refrigeration cycle uses water as the refrigerant and lithium bromide as the absorbent. It is the strong affinity and ease of separation that these two substances have for each other that makes the cycle work. The entire process occurs in hermetic vessels in a near complete vacuum.

Single stage hot water driven absorption chiller

YHAU CL



Two Step Evaporator and Absorber Design

Efficiency, Reliability, Cost of Ownership

The innovative 2-step evaporator and absorber design is more efficient than a conventional cycle. This ingenious design splits the absorption process into two steps, similar to how a series-counter-flow arrangement splits the work between two chillers. The result of the design allows the **YHAU-CL** to perform the absorption function with lower solution concentrations than conventional designs, increasing efficiency and reliability, and decreasing cost of ownership.

Reliability is enhanced because the solution concentrations are lower leaving the absorber, which allows the entire cycle to operate at lower concentrations virtually eliminating the possibility of crystallization. Efficiency is enhanced because the **YHAU-CL** can take advantage of lower than normal hot water temperatures in the generator. This is because at lower concentrations the solution will boil at a lower temperature in the generator.

Lastly, total operating cost decreases because of the lower concentration of the solution entering the generator, a wider temperature range of hot water can be used, reducing pumping horsepower.

Full Automatic Purging System

As a standard feature, the unit has a fully automatic purging system comprising of electronic vacuum transmitter, solenoid valves and trending capability that ensures design performance and improves reliability. The operator does not have to worry about the sequence of purging for removing the non-condensable gases.

Chiller control

The **YHAU Control Center**, standard on each chiller, provides the ultimate in efficiency, monitoring, data recording, chiller protection and operating ease.

The LCD display allows graphic animated display of the chiller, chiller sub-systems and system parameters; this allows the presentation of several operating parameters at once. In addition, the operator may view a graphical representation of the historical operation of the chiller as well as the present operation. The panel is capable of communication with building management systems and is available in multiple languages.

Nominal capacity

YHAU CL Model	30EXE	40EXE	50EXE	65EXE	80EXE	100EXE	130EXE	160EXE	200EXE	255EXE	320EXE	400EXE	500EXE
Cooling Capacity kW	105	141	179	222	271	352	443	563	721	869	1125	1407	1758
COP (low temperature hot water)	0,78	0,78	0,78	0,78	0,78	0,76	0,78	0,78	0,78	0,78	0,78	0,78	0,78

YHAU CL Model	630EXW	700EXW	800EXW	900EXW	1000EXW	1120EXW	1250EXW	1400EXW	1500EXW	1600EXW	1680EXW	1800EXW	1900EXW	2000EXW
Cooling Capacity kW	1934	211	2461	2708	3024	3411	3938	4431	4852	5134	5274	5626	5943	6153
COP (low temperature hot water)	0,78	0,78	0,78	0,78	0,78	0,78	0,78	0,78	0,78	0,78	0,78	0,78	0,78	0,78

At 6°C leaving chilled water, 90°C entering generator water, and 27°C entering condenser water.

Technical data

YHAU CL Model			30EXE	40EXE	50EXE	65EXE	80EXE	100EXE	130EXE	160EXE	200EXE	255EXE	320EXE	400EXE	500EXE
Dimensions	Length	mm	1900	2200	2500	3100	2200	2600	3200	3800	4600	3300	3900	4700	5700
	Width	mm	1500				1800				2200				
	Height	mm	2100				2500				3200				
Operating weight kg			2700	3100	3600	4200	4400	5100	6100	7200	8500	10300	12200	14400	17400

YHAU CL Model			630EXW	700EXW	800EXW	900EXW	1000EXW	1120EXW	1250EXW	1400EXW	1500EXW	1600EXW	1680EXW	1800EXW	1900EXW	2000EXW
Dimensions	Length	mm	5500	6000	6700	7300	8000	6700	7300	8000	8500	9000	9500	10000	10500	11000
	Width	mm	2650				3300				3900					
	Height	mm	3300				3900				3900					
Operating weight kg			25800	27600	29500	32300	34700	43900	46400	49000	51200	53500	55800	58600	61300	64100



Manufacturer reserves the rights to change specifications without prior notice.

YORK® absorption chillers and heat pumps

With innovative 2-step evaporation and absorption-cycle technology

DRIVING HEAT SOURCE	MODEL AND DESCRIPTION	
HOT WATER	<p>Single Effect Hot Water Model: YHAU-CL Capacity: 105 - 6,153 kW / 30 - 1,750 TR Application: Combined heat and power (CHP), commercial cooling, industrial process cooling</p>	
LOW PRESSURE STEAM	<p>Single Effect Steam Fired Model: YHAU-C Capacity: 422 - 5,275 kW / 120 - 1,500 TR Application: Combined heat and power (CHP), commercial cooling, industrial process cooling</p>	
MEDIUM PRESSURE STEAM	<p>Double Effect Steam Fired Model: YHAU-CW Capacity: 422 - 14,065 kW / 120 - 4,000 TR Application: Combined heat and power (CHP), commercial cooling, industrial process cooling</p>	
DIRECT FIRED	<p>Small Double Effect Natural Gas or Light Oil * Model: YHAU-F Capacity: 105 - 352 kW / 30 - 100 TR Application: Commercial cooling</p>	
DIRECT FIRED	<p>Large Double Effect Natural Gas or Light Oil Model: YHAU-CG Capacity: 422 - 4,395 kW / 120 - 1,250 TR Application: Commercial cooling, industrial process cooling</p>	
EXHAUST GAS	<p>Double Effect Direct Exhaust Gas Model: YHAU-CE Capacity: 527 - 3,516 kW / 150 - 1,000 TR Application: Combined heat and power (CHP)</p>	

* Utilizes standard cycle

YORK® absorption chillers and heat pumps

With innovative 2-step evaporation and absorption-cycle technology

DRIVING HEAT SOURCE	MODEL AND DESCRIPTION	
EXHAUST GAS AND LOW TEMPERATURE HOT WATER	<p>Multi Energy Model: YHAU-CE-J Capacity: 527 - 3,516 kW / 150 - 1,000 TR Application: Combined heat and power (CHP)</p>	
EXHAUST GAS AND LOW TEMPERATURE HOT WATER AND DIRECT FIRED	<p>Multi Energy Model: YHAU-CGE-J Capacity: Custom Application: Combined heat and power (CHP), commercial cooling</p>	
NATURAL GAS AND LOW TEMPERATURE HOT WATER	<p>Gas Gene-Link Model: YHAU-CG-J Capacity: 422 - 4,395 kW / 120 - 1,250 TR Application: Combined heat and power (CHP), commercial cooling</p>	
MEDIUM PRESSURE STEAM AND LOW TEMPERATURE HOT WATER	<p>Steam Gene-Link Model: YHAU-CW-J Capacity: 422 - 14,065 kW / 120 - 4,000 TR Application: Combined heat and power (CHP), industrial process cooling</p>	
MEDIUM PRESSURE STEAM, DIRECT FIRED, HIGH TEMPERATURE HOT WATER	<p>Double Effect Low Temperature (-5°C) Model: YHAU-C-L Capacity: 176 - 1,758 kW / 50 - 500 TR Application: Industrial process cooling (food & beverage)</p>	
LOW PRESSURE STEAM, MEDIUM PRESSURE STEAM, DIRECT FIRED	<p>Single Effect Absorption Heat Pump (Up to 90°C) Model: YHAP-C Capacity: 900 - 40,000 kW Application: District heating, industrial process heating</p>	

WFC SC Single stage hot water absorption chiller

Cooling capacities from 17.6 kW to 175.8 kW

CH K & CH MG Natural gas-fired chiller/heaters

Cooling capacities from 105 kW to 703 kW

Heating capacities from 86 kW to 572 kW



Features WFC SC

WFC SC chillers from **Yazaki** are single stage hot water driven chillers. Compared to electrically driven chillers the **WFC SC** series can dramatically lower system operating costs when using waste heat. Applications particularly well suited to the **Yazaki WFC SC** absorption chiller include waste heat recovery from cogeneration or biomass, waste heat from district power station or industry as well as solar thermal. This makes absorption cooling an environmentally friendly and cost-saving alternative to conventional air-conditioning systems. A low electrical energy consumption results in low CO₂ emissions and provide a relief for electricity grids by replacing conventional cooling demand peaks. All chillers are pre-filled and ready for "plug & chill".

Driving heat source hot water

WFC SC units can operate with entering hot water temperature from 70 to 95°C.

Refrigerant cycle

The **Yazaki WFC SC** high efficiency single-stage absorption refrigeration cycle uses water as the refrigerant and lithium bromide (non-flammable, non-toxic, ecologically benign and ozone-friendly) as the absorbent. It is the strong affinity and ease of separation that these two substances have for each other that makes the cycle work. The entire process occurs in hermetic vessels in a near complete vacuum.

Features CH K & CH MG

Natural gas-fired chiller/heaters **CH K & CH MG** from **Yazaki** work with double effect thermo-cycle and may be used for both cooling or heating distribution. Compared to electrically driven chillers **CH K & CH MG** chillers can dramatically lower system operating costs.

A low electrical energy consumption results in low CO₂ emissions and provide a relief for electricity grids by replacing conventional cooling demand peaks. All chillers are pre-filled and ready for "plug & chill".

Direct fired chiller

Driving energy is provided by natural gas. Typically a COP of 1.0 or above is achievable.

Refrigerant cycle

The **Yazaki CH K & CH MG** high efficiency double-effect absorption refrigeration cycle uses water as the refrigerant and lithium bromide (non-flammable, non-toxic, ecologically benign and ozone-friendly) as the absorbent. It is the strong affinity and ease of separation that these two substances have for each other that makes the cycle work. The entire process occurs in hermetic vessels in a near complete vacuum.

Single stage hot water absorption chiller

WFC SC

Natural gas-fired chiller/heaters

CH K & CH MG



Nominal capacity WFC SC

Model				WFC SC 05	WFC SC 10	WFC SC 20	WFC SC 30	WFC SC 50
Cooling Capacity		kW		17.6	35	70	105	175.8
Sound pressure at 1 m		dB(A)		46	46	49	52	52
Cold water	Temperature	Inlet	°C	12.5	12.5	12.5	12.5	12.5
		Outlet	°C	7	7	7	7	7
Cooling water	Cooling performance		kW	42.7	85.5	171	256	427
	Temperature	Inlet	°C	31	31	31	31	31
		Outlet	°C	35	35	35	35	35
Hot water	Power consumption		kW	25.1	50.2	100.4	150.6	251
	Temperature	Inlet	°C	88	88	88	88	88
		Outlet	°C	83	83	83	83	83

Technical data WFC SC

Model			WFC SC 05	WFC SC 10	WFC SC 20	WFC SC 30	WFC SC 50
Dimensions	Length	mm	594	760	1060	1380	1785
	Width	mm	744	970	1300	1545	1960
	Height (with mounting plate)	mm	1756	1920	2030	2065	2085
Operating weight		kg	420	604	1156	1801	2650

Nominal capacity CH K & CH MG

Model				CHK 30	CHK 40	CHK 50	CHK 60	CHK 80	CHK 100	CHMG 150	CHMG 200
Cooling Capacity		kW		105	141	176	211	281	352	527	703
Heating Capacity		kW		86	115	143	172	229	286	429	572
Chilled water	Temperature	Inlet	°C	12.5	12.5	12.5	12.5	12.5	12.5	12	12
		Outlet	°C	7	7	7	7	7	7	7	7
Cooling water	Temperature	Inlet	°C	29.5	29.5	29.5	29.5	29.5	29.5	29.5	29.5
		Outlet	°C	35.5	35.5	35.5	35.5	35.5	35.5	35.5	34.6
Hot water	Temperature	Inlet	°C	50.5	50.5	50.5	50.5	50.5	50.5	56	56
		Outlet	°C	55	55	55	55	55	55	60	60

Technical data CH K & CH MG

Model			CHK 30	CHK 40	CHK 50	CHK 60	CHK 80	CHK 100	CHMG 150	CHMG 200
Dimensions	Length	mm	1635	1635	1875	1875	1995	1995	3663	3735
	Width	mm	1460	1460	1780	1780	1840	1840	1951	2051
	Height (with fixed plate and vent cap)	mm	2440	2440	2440	2440	2820	2820	2763	3003
Operating weight		kg	1720	1970	2510	2770	4060	4540	6210	7340



Manufacturer reserves the rights to change specifications without prior notice.



Central Plant Optimization™ 10

A facility's central chiller plant typically uses 20% of the building's total energy. Managing this load, while still maintaining occupant comfort, is a primary strategy for overall energy management.

Johnson Controls® Central Plant Optimization™ 10 (CPO 10) provides such a strategy combining expertise from designing YORK® chillers and Metasys® controls to save energy and improve reliability in the facility.

The application uses tested best practices to select the most efficient combination of chillers, pumps and cooling towers to match the building load. It then commands the selected devices providing the necessary sequencing of pumps, isolation valves and main equipment, while observing safety and stability operation requirements.

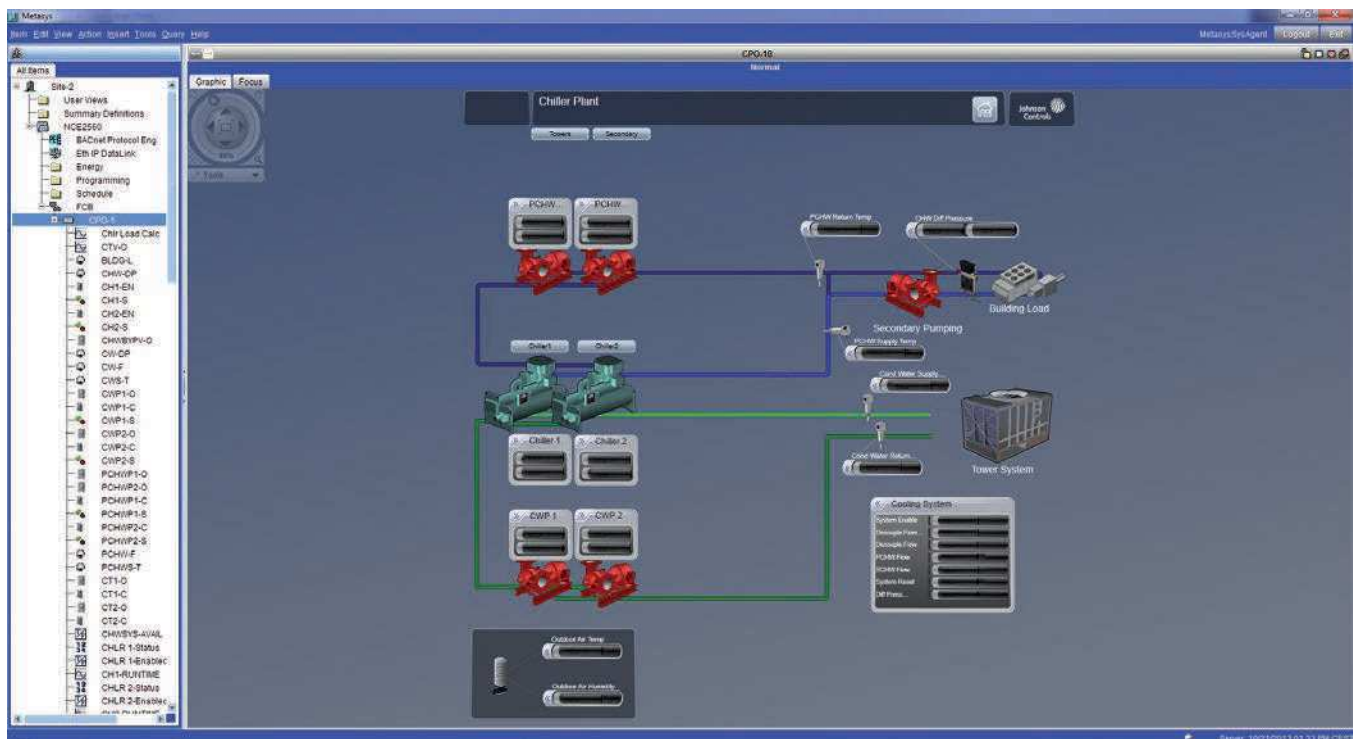

Creating a complex program without programming

The System Selection Tool (SST) is a control program generator that relies on defining the characteristics of the chiller plant and its control strategies. The tool supports **selection and sequencing** of

- up to eight chillers of different sizes, compressor types and fixed or variable speed
- up to eight (each) primary and secondary chilled water pumps of varying pumping capacities
- up to eight condenser water pump
- of cooling towers and bypass valve, including single speed, multi-speed, and vernier control (one variable speed fan with all other tower fans at constant speed)
- up to four heat exchangers (Waterside Economizers)
- both water-cooled and air-cooled chillers

Furthermore, **control definition** for the chiller plant in a single Field Equipment Controller (FEC)/Network Controller Engine (NCE), if supported by available memory and point Input/Output (I/O), or split across multiple FECs/NCEs, is offered.

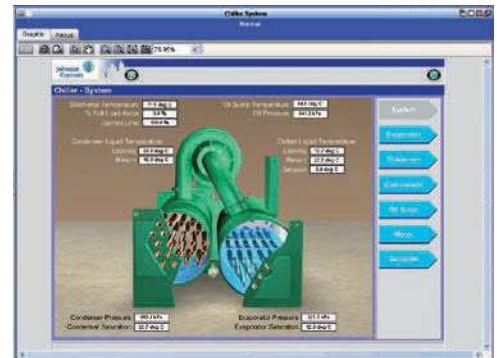

Flexibility, ready for use

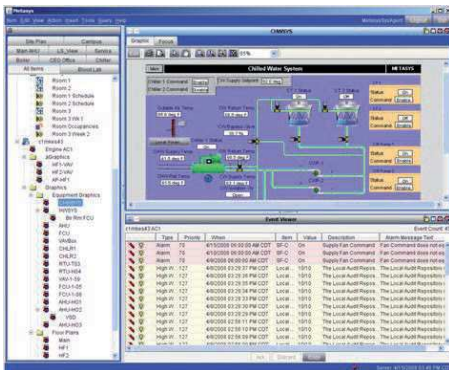

A **variety of primary control strategies** are also available, including

- measuring building chilled-water flow and differential temperature
- chiller load (kW)
- flow through a decoupler pipe in a primary/secondary system
- differential temperature only, in a constant speed chilled water pump system

It is also possible to select **dozens of secondary strategies**, such as

- open loop control of the cooling towers (as defined by the American Society of Heating, Refrigerating and Air-Conditioning Engineers)
- closed loop control of condenser-water setpoint

After making the selections, SST **generates a complete program** by linking together appropriate software modules. This process removes the variability commonly found in totally custom-generated programs using a traditional software program editor.

Once the software modules are linked, the tool allows the entry of all equipment parameters. The resulting program can also be run in a simulator mode to verify proper operation before downloading it into Metasys®.



Manufacturer reserves the rights to change specifications without prior notice.

Heat Pump Solutions

According to the Environmental Protection Agency (EPA), it is estimated that 5% of the world's daily energy consumption is expended on fuel for heating water. Additionally, in Western European countries, 25 % of primary energy used is for cooling and heating applications. As pressure continues on natural resources and energy bills continue to rise, we must seek new, environmentally friendly solutions.

One smart option is to improve the energy utilization of your facility's heating and cooling system by recycling heat energy that would otherwise be rejected. This can be accomplished with a Johnson Controls heat pump.

At Johnson Controls we set standards without compromising our core principles: and when passion and innovation come together, great things happen!

What is a Heat Pump?

Heat pumps are designed to produce hot water at a specified temperature. Heat is extracted from a low-temperature source such as air, ground water, or waste process heat, and its temperature is raised to a level where it can be used in alternative processes.

There are 4 primary system designs for heat pumps:

- 1) **Air-source** – An example of this is the heat pump you may have in your home.
- 2) **Ground-source** – This system uses the ground as the heat source, often used in residential or light commercial applications.
- 3) **Water-source** – This system uses a building's water supply to transfer heat. This is the most commonly used system.
- 4) **Cascade-source** – The system uses heat from existing refrigerant systems or any available waste heat source.

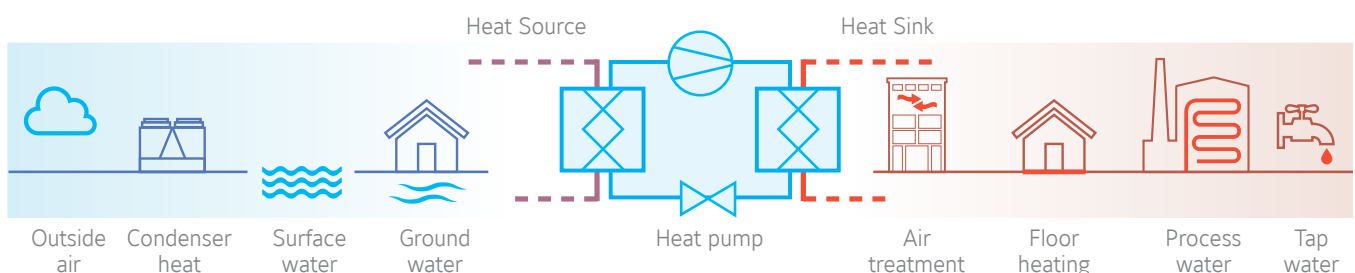

Traditionally, chillers are used to provide a building's required cooling load (rejecting heat to atmosphere via cooling towers) and boilers supply hot water to meet the building's heating needs. Using a Heat Pump gives increased system efficiency and lowers operating expense as they can supplement or even replace existing heating systems, and can also operate in reverse cycle to provide cooling during the summer. There are also processes in which cooling and heating functions perform simultaneously. Again, heat pumps are an ideal solution to this challenge.

Benefits of using heat pumps

Traditional systems used to heat water for hydronic heating and domestic hot water are not energy efficient. Heat pumps offer a number of advantages when compared to fossil-fuel water heaters:

- ▶ Higher COPs offer **energy cost-savings above 50%**.
- ▶ Thanks to their efficiency and short amortization period, they represent an environmentally compatible and economically attractive alternative to conventional heating systems. **Potential payback of the heat pump can be less than 2 years.**
- ▶ **Low operating-cost supplement** to water heaters where total heating requirement exceeds heat pump capacity.
- ▶ **Heat pumps can also be used as water chillers**, which means lower first-costs, as one item of equipment performs cooling and heating.
- ▶ **Life cycle of over 20 years.**

Johnson Controls heat pumps offer additional benefits by using environmentally friendly HFC and natural refrigerants, with **zero ozone depletion potential, and low global warming potential.**









Reduced operating costs

The best way to compare the efficiency of a heat pump and a water heater is to do a COP analysis. COP equals the energy output (useful heat generated) divided by the energy input (energy supplied to the equipment).

Accordingly, the higher the COP, the more efficient the system – and the lower your running costs!

As an example we can take a 1800 kW water-cooled heat pump as the one showed in chart and compare it to a natural gas boiler. When you compare the efficiency of a boiler to a heat pump, the heat pump comes out way ahead.

In the example given it's possible to save up to 53% in the energy bill vs the traditional natural gas boiler!

Hot Water Requirement	Energy Source	Efficiency	Energy Consumption	Cost of Source*	Cost of Hot Water Requirement	HP Saving vs Gas Boiler
1 kWh 	Natural Gas Boiler 	Average efficiency COP=0.9	 1 kWh / 0.9 1.11 kWh	European Avg. Gas Cost 0.041 €/kWh	1.11 kWh x 0.041€/ kWh 4.5 c€	-
1 kWh 	Air cooled Heat Pump 	Average efficiency COP=3.2	 1 kWh / 3.2 0.31 kWh	European Avg. Electricity Cost 0.12 €/kWh	0.31 kWh x 0.12€/ kWh 3.7 c€	18%
1 kWh 	Water cooled Heat Pump 	Average efficiency COP=5.5	 1 kWh / 5.5 0.18 kWh	European Avg. Electricity Cost 0.12 €/kWh	0.18 kWh x 0.12€/ kWh 2.1 c€	53%

* Cost of Source: Eurostat Statistics web site.













CO₂ footprint reductions

Another benefit that offers heat pump technology is the reduction in CO₂ emissions from fossil fuel use. Heat pumps are a highly efficient electric alternative.

If we refer to the same example with a 1800 kW water-cooled heat pump and compare it to a natural gas boiler, the reduction in CO₂ emissions is impressive.

In fact 1322 tons of CO₂ annually can be saved, which is the equivalent of removing about 278 cars* from the road!

* www.epa.gov/cleanrgy/energy-resources/calculator.html

Hot Water Requirement	Energy Source	Efficiency	Energy Consumption	CO ₂ Source Emissions*	Carbon Footprint	HP CO ₂ footprint reduction vs Gas Boiler
1 kWh 	Natural Gas Boiler 	Average efficiency COP=0.9	 1 kWh / 0.9 1.11 kWh	CO ₂ Emissions 204 g CO ₂ / kWh	 1.11 kWh x 204g CO ₂ /kWh 226 g CO ₂	-
1 kWh 	Air cooled Heat Pump 	Average efficiency COP=3.2	 1 kWh / 3.2 0.31 kWh	CO ₂ Emissions 541 g CO ₂ / kWh	 0.31 kWh x 541g CO ₂ /kWh 167 g CO ₂	26%
1 kWh 	Water cooled Heat Pump 	Average efficiency COP=5.5	 1 kWh / 5.5 0.18 kWh	CO ₂ Emissions 541 g CO ₂ / kWh	 0.18 kWh x 541g CO ₂ /kWh 97 g CO ₂	57%

* CO₂ Source Emissions: UK Department of Energy, Food and Rural Affairs and carbonindependent web site

Reduced water and chemical consumption

When a heat pump is operating we are keeping heat within the building and not rejecting heat to the atmosphere. In other words, we're saving condenser water from evaporating.

So when we look at our same 1800 kW water-cooled heat pump example again, how much water are we saving by not expelling heat to the atmosphere from the cooling tower?

Over 26 million litres annually!

LEED points

Heat pumps will help you and your customers get LEED points. LEED is one of the most recognizable bodies that certifies building designs to demonstrate leadership in environmental impact.

The use of a heat pump also helps accreditation for BREEAM and other similar schemes.



Heat Pumps solutions

We do have a wide range of industrial heat pumps for several capacities and at different temperature levels.

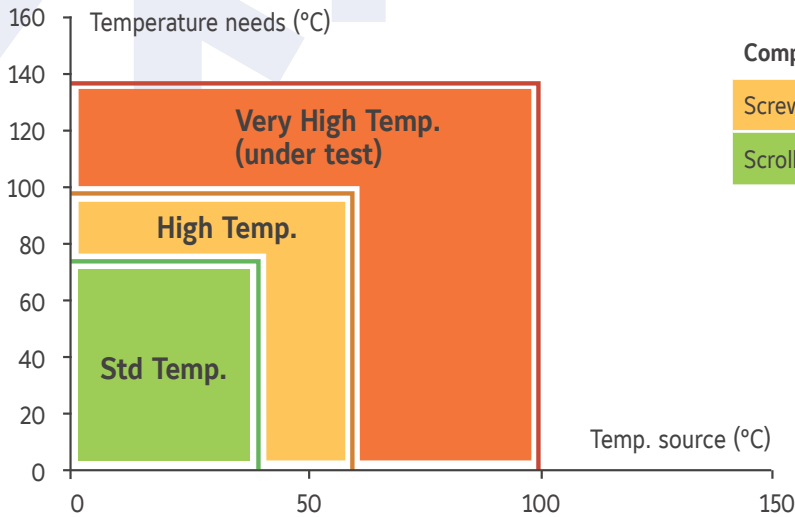

Compressor type	Refrigerant
Screw, centrifugal	R717, R245fa
Scroll, reciprocating, screw	R717, R134a, R410A

Heat pumps with standard temperature



YLHA
Air to water heat pump
Scroll compressor / R410A
Hot water up to 50°C
Heating capacity: 12 to 150 kW



YLHD
Air to water heat pump
Scroll compressor / R410A
Hot water up to 50°C
Heating capacity: 23 to 160 kW



YCAE-R
Air to water heat pump
Scroll compressor / R410A
Hot water up to 52°C
Heating capacity: 70 to 100 kW



YLRA
Air to water heat pump
Scroll compressor / R410A
Hot water up to 55°C
Heating capacity: 200 to 327 kW



YMWA
Water to water heat pump
Scroll compressor / R410A
Hot water up to 55°C
Heating capacity: 25 to 210 kW



YCSE
Water to water heat pump
Screw compressor / R134a
Hot water up to 55°C
Heating capacity: 170 to 300 kW

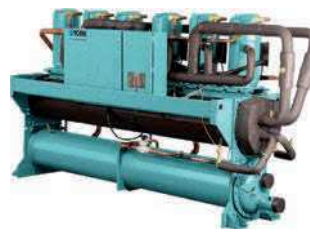

YCWL
Water to water heat pump
Scroll compressor / R410A
Hot water up to 52°C
Heating capacity: 210 to 675 kW



YLCS
Water to water heat pump
Twin screw comp. / R134a
Hot water up to 70°C
Heating cap.: 400 to 2000 kW



YVWA
Water to water heat pump
Screw compressor / R134a
Hot water up to **65°C**
Heating cap.: 650 to 1250 kW



YMC²
Water to water heat pump
Variable speed centrif. compr. / R134a
Magnetic bearings / R134a
Hot water up to **65°C**
Heating cap.: 1600 to 2800 kW



HeatPAC recip
Variable-Speed Drive
Reciprocating compr. / R717
Hot water up to **70°C**
Heating capacity up to 1200 kW at 40°C source



YK HP
Water to water heat pump
Centrifugal compr. / R134a
Hot water up to **50°C (Std) & 70°C (HP)**
Heating cap.: 1000 to 9000 kW

Heat pumps with high temperature



HeatPAC HPX recip
Variable-Speed Drive
Reciprocating compr. / R717
Hot water up to **90°C**
Heating capacity up to 600 kW at 40°C source



HeatPAC
Variable-Speed Drive
Screw compressor / R717
Hot water up to **90°C**
Heating capacity up to 1600 kW at 40°C source



SHP
Water to water heat pump
Screw VSD compr. / R134a
Hot water up to **80°C**
Heating cap.: 700 to 3000 kW



YHAP-C
Single stage absorption
Steam, Gas or Hot Water driven / R718
Hot water up to **95°C**
Heating cap.: 900 to 40000 kW

Customized Heat Pumps



Oil Free Centrifugal HP
Water to water heat pump
Magnetic centrifugal compressor
R134a Hot water up to **70°C**
R245fa Hot water up to **105°C**
Heating capacity from 700 to 1800 kW



HeatPAC Custom
Two-stage cascade VSD
Screw compressor / R717
Hot water up to **90°C**
Reciprocating compressor / R717
Hot water up to **70°C**
Heating cap. up to +3000 kW at 40°C source



CYK HP / Titan OM HP
Water to water heat pump
Centrifugal compressor / R134a
CYK HP: Hot water up to **70°C**
Heating capacity from 2500 to 7000 kW
Titan OM HP: Hot water up to **90°C**
Heating capacity from 5000 to 20000 kW

Manufacturer reserves the rights to change specifications without prior notice.



Air Handling Systems & Terminal Devices

AIR HANDLING UNITS

FAN COIL UNITS

CLOSE CONTROL UNITS

SMARTPAC – FACTORY PACKAGED CONTROLS

So why choose YORK® Air Handling Units?

We recognise that your reputation depends on the quality of the products you choose and how well they are installed. That's why we work hard to make selecting, installing and operating our products as easy as possible. Our comprehensive range includes a number of additional options that make YORK® Air Handling Units the professional's choice.

Factory Packaged controls

Save money and time avoiding to mount controls on-site. Johnson Controls offers YORK® Air Handling Units complete with Metasys® factory packaged controls so it is ready connect to the site network when it arrives.

Our Factory Packaged controls undergo a detailed testing process at the factory to ensure that all wiring is installed correctly, and that all control panels and end devices work appropriately before the AHU is shipped.



Factory Packaged Controls option

- AHUs Metasys® factory packaged controls specified option available.
- Panel Power wiring, Controls wiring and the Variable Speed Drive are included. The pre-engineered controller and required peripheral devices are all supplied factory fitted and tested.
- Guaranteed compliance with European installation regulations.
- Simplified final commissioning through the units' keypad and display.

Energy recovery options

The exhaust air stream from an AHU represents another opportunity to save energy. A **heat recovery 'thermal' wheel** can economically transfer heat and moisture between the exhaust-air and outside-air paths, reducing the cost of conditioning the supply air.

For the simplest form of heat recovery, you can take advantage of **"free" cooling** with mixing box sections. During spring and autumn operation, cool/dry outside air cools and dehumidifies the facility, reducing the need for mechanical cooling.

Alternatively, you can use **recuperative plate heat exchangers**. These also allow free cooling in summer by use of face and bypass dampers which by-pass the air around the exchanger so that it is not warmed by the extracted air.

We can also offer **refrigerant heat pipe** and **heat recovery coils** on your AHU to maximise energy savings. All heat recovery devices installed are compliant with latest ErP regulations.



Heat-recovery wheels reduce the cost of conditioning supply air.

Reduce fan operating costs

In an AHU, the fan is traditionally the largest source of energy consumption. We can help reduce this by offering a range of **energy-saving options**.

- High- or premium-efficiency motors can be specified.
- Direct-drive plenum fans eliminate belt-and-pulley energy losses.
- If the air system is designed for variable-air volume (VAV), YORK® AHUs fitted with variable speed drives offer the most efficient method of VAV fan control.
- Factory-mounting a variable speed drive reduce jobsite labour costs, unit energy consumption and unit Life Cycle Costs.

Introducing the YMA range of Air Handling Units



The YORK® YMA range encompasses our extensive knowledge of air-handling, offering a highly reliable, economical and energy efficient product capable of addressing all of your needs.

Features

The YMA family of air handling units consists of a range of models having air volumes ranging from 0.25 m³/s to 50 m³/s and total static pressures as high as 2000 Pascal: to ensure maximum flexibility and the best solution for your application, units are available in increments of 40mm in height and 50mm in width.

YMA Air Handling Units can be manufactured in varied configurations, with a wide selection of components, to meet customer requirements. Units are also available in line with the requirements of hospital sector specifications.

Dimensional flexibility. Space constraints are a reality on most construction projects. YORK® AHU's design is based on variable aspect ratios, so the unit can be specified to fit the application and space.

Material flexibility. Different environments require different materials so we offer a number of construction materials, including galvanized steel, pre-coated steel, stainless steel, and aluminium.

Component flexibility. To meet any AHU requirement, our units offer every available air-handling component. And as applicable technology creates new capabilities, Johnson Controls will apply this to our product range.

Over the past 50 years we have supplied air handling units for:

- **Commercial space:** office buildings, cinemas, concert halls
- **Institutional space:** schools, universities, churches
- **Industrial manufacturing:** automotive, aerospace, chemical, petrochemical
- **Hygienic systems:** hospitals, life sciences, R&D facilities, food processing, clean rooms
- **Process manufacturing:** pharmaceutical, electronics, semiconductor

YMA Custom Air Handling Units

A complete range from 0.25 m³/s to 50 m³/s



Features

The YMA family of air handling units consists of a range of models having air volumes ranging from 0.25 m³/s to 50 m³/s and total static pressures as high as 2000 Pascal: to ensure maximum flexibility and the best solution for your application, units are available in increments of 40mm in height and 50mm in width.

YMA Air Handling Units can be manufactured in varied configurations, with a wide selection of components, to meet customer requirements.

Units are also available in line with the requirements of hospital sector specifications.



Units may include combinations of any of the following:

- Single or double decked units.
- Indoor or outdoor applications – Outdoor units are available with a flat or sloping roof, louvres, rainhoods, birdscreens and special finishes.
- Site assembled units.
Where space constraints restrict the size of a single item modules can easily be aligned and locked together by gaskets and stainless steel bolts inserted into factory predrilled assembly holes.
- Air mixing boxes and various filter options.
- Gas fired burners.
- Cooling and heating coils.
- Humidifiers
- Heat recovery systems.
- UV sterilising lamps.
- Dessicant and thermal wheels.
- Sound attenuation.
- ATEX Certification.
- Factory fitted controls and sensors with YORK SmartPAC Factory Packaged Controls.
These include all necessary piping, wiring, controls and refrigeration equipment to provide a complete central air conditioning plant.



Manufacturer reserves the rights to change specifications without prior notice.

Fans (*)

- One or two double inlet, double width forward or backward curved centrifugal fans
- Aerodynamic inlets design, with static and dynamic balancing of the wheels according to airflow and speed
- Sealed for life bearings for smaller fans, whereas larger versions have block type self aligning ball journals and split blocks with grease points
- Removable fan guards dedicated to vee belt fan drives
- Motors protection is ensured by an enclosed fan cooled type class F insulation to IP55 (Category 2 Zone 1 ATEX certified motors available as an option)
- Total fan assembly installed on a separate frame isolated from the unit structure by spring anti-vibration mounts
- Plenum type fans available for applications where plant space is a premium. The plenum fan pressurises an acoustically lined fan chamber and circular or rectangular discharge duct connections can be located on the external faces of the chamber. This reduces the length of the air handling plant by eliminating the need for external attenuators or complicated duct transformation pieces.

Plenum Fan Configuration

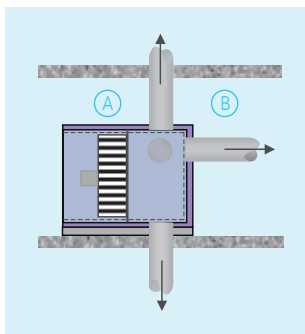

- (A) Acoustically Lined Fan Section
- (B) Supply Air Ducts

Cooling and Heating Coils

Cooling and heating coils are computer selected to achieve the optimum thermal and psychrometric efficiency with low air and water pressure drops.

Gas Burners

- Indirect gas fired burners with an optional choice of on/off, staged, or fully modulating control, and are suitable for use in both draw through and blow through applications
- Burner design ensures no transition sections from the fan are necessary on draw through systems, thereby reducing fabrication cost
- Burners can be horizontally mounted on "downflow" applications, eliminating the need for turning sections and saving cost, space and weight
- Low NOx / carbon monoxide free burners also available in order to increase safety and reduce atmospheric pollution

(*) Please contact local sales office for fan application details.



Sound Attenuation

Standard attenuation sections comprise baffles of galvanized steel and non-hygroscopic material, with option for either perforated plate or 'melonex' liners.

Heat Recovery

YMA air handling units are available with a range of Heat recovery devices that reduce energy usage and lower the equipment running costs...



Factory Packaged Controls

All units can be supplied with factory fitted controls, sensors and control panels. Using YORK SmartPAC packaged control system incorporating Johnson Controls range of system controllers, units are supplied to site pre-wired, programmed and tested thus saving time and money associated with traditional site installation and commissioning methods. All installations will be compliant with the latest applicable National/ European codes.



YORK® Fan Coil units

Driven by innovative trends and modern technology, the YORK® Fan Coil Units have been designed around a platform of models, versions and accessories, which have been independently tested and certified by Eurovent. The YORK® Fan Coil range meets today's demanding requirements of performance, size, acoustics, low energy, ease of installation and maintenance.



An extensive offering

- One of the **most versatile** ranges of fan coils on the market today. Wall and ceiling mounted units, exposed or concealed with centrifugal fan, are included, and with cooling capacities ranging from 0.6 kW to 9.5 kW.
- Dramatic **electrical consumption reduction** of up to 40% comparative to previous models. This is achieved thanks to the supply of all YORK® Fan Coil Units equipped with centrifugal fans and electric motors, and with 6 speed motors as standard to offer greater flexibility in the selection of products.
- **Energy saving brushless motor** technology option available. Its combination with a dedicated frequency inverter and unit controller to regulate the fan speed enables higher efficiencies, even at low rotational speeds, lower unit noise, constant speed characteristics and an increase in motor lifetime expectancy. In comparison to the traditional units equipped with asynchronous three-speed-motors, units with brushless motors can obtain a considerable energy saving, by reducing the power consumption by up to 70%.
- A full range of **factory fitted Johnson Controls valve and pre-configured control options** is offered. This in addition to a patented 'wireless' control option - offering greater flexibility in the installation of units, with the highest precision in monitoring and maintaining the desired comfort conditions.
- **High pressure 'Blower' units** are also available. They can offer up to 31.5 kW of cooling at External Static Pressures of up to 250Pa, and are complemented with a full range of options and accessories covering items such as electrical heating battery, air inlet/outlet diffusers and condensate pumps.



Iconography

Infrared or Wired control	Wired control	Dry mode	Timer	Auto Restart	Sleep mode	Auto Sweep	Ducted Installation	4 Way Air Flow	Air Filter

YFCN Fan Coil Unit centrifugal fan

2 & 4 pipe system

A complete range from 1.0 kW to 7.6 kW



YFCN is a range of Fan Coil Units that continues the YORK® tradition based on high reliability and low noise levels. It is the result of great commitment in terms of energy and resources to offer a more modern product from every angle, while still delivering the convenience of easy access to the filters in all models.

Moreover each version has the same internal structure, identical in both horizontal and vertical models, in order to standardise production and guarantee a greater flexibility in distribution and installation.



Selection software

Wired controls



JWC-3V

Remote three speeds controller

JWC-T

JWC-3V + Electronic thermostat and Summer/Winter switch

JWC-AU

Automatic JWC-T



JTM-B

Digital Automatic Remote controller

TMO 503 SV2

Digital Automatic Remote controller to be mounted in the standard light wall box



Infrared control



TUC03 Terminal unit controller

BacNET and N2 Metasys network compatible

Features

- New casing, improved aesthetics, suitable for any modern indoor ambient
- Full range for all needs: 9 sizes suitable for horizontal or vertical mounting with or without casing
- Wireless control option
- Low noise operation
- 3 fan speeds (possible choice between 6 fan speeds)
- Single piece discharge grid
- Several coil choices. Single: 3 or 4 rows; Dual: 3 rows cooling & 2 rows heating
- Electrical heater optional
- Suction and discharge plenum optional
- Factory fitted valve (on/off or modulating) and controller packages
- Painted back panel option
- 4 available versions in all range:
 - VC = Vertical Discharge with Casing
 - VCB = Vertical Discharge with Casing (floor installation)
 - HC = Horizontal Discharge with Casing
 - CD = Concealed unit without Casing

YFCN Fan Coil Unit centrifugal fan

1.0 to 7.6 kW

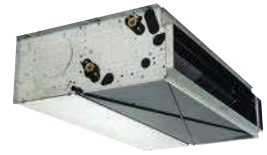

Technical features

Model		140	240	340	440	540	640	740	840	940	
Total cooling capacity [kW]	(1)	max	1.23	1.81	2.57	3.12	4.09	4.79	5.58	6.47	7.6
		med	1.02	1.43	1.89	2.28	3.25	3.86	4.64	5.73	6.54
		min	0.67	1.01	1.65	1.83	2.19	2.83	3.56	4.03	4.88
Sensible cooling capacity [kW]	(1)	max	0.97	1.38	1.9	2.34	3.07	3.6	4.23	5.06	6.05
		med	0.79	1.07	1.38	1.68	2.4	2.86	3.47	4.43	5.11
		min	0.51	0.74	1.2	1.34	1.6	2.07	2.62	3.04	3.72
Water flow in cooling [l/h]	(1)	max	212	311	442	537	703	824	960	1 113	1 307
		med	175	246	325	392	559	664	798	986	1 125
		min	115	174	284	315	377	487	612	693	839
Pressure drop in cooling [kPa]	(1)	max	5.6	13.9	11.5	15.5	31.3	36.2	27.7	17.5	23.2
		med	4	9.2	6.7	9	20.8	24.8	20	14.1	17.8
		min	1.9	4.9	5.3	6.1	10.4	14.4	12.5	7.6	10.6
Heating capacity 2 pipes [kW]	(2)	max	1.55	2.2	3.07	3.76	4.83	5.88	6.71	8.43	10.08
		med	1.27	1.72	2.23	2.72	3.81	4.69	5.55	7.36	8.53
		min	0.82	1.18	1.94	2.16	2.53	3.39	4.2	5.06	6.22
Water flow in heating 2 pipes [l/h] *	(2)	max	212	311	442	537	703	824	960	1 113	1 307
		med	175	246	325	392	559	664	798	986	1 125
		min	115	174	284	315	377	487	612	693	839
Pressure drop in heating 2 pipes [kPa]	(2)	max	4.7	11.6	9.2	12.2	25.7	29.3	23.7	14.5	19.3
		med	3.3	7.5	5.4	6.9	17	19.5	16.9	11.4	14.8
		min	1.5	3.9	4.2	4.6	8.3	11	10.3	6.2	8.7
Air flow [m3/h]		max	220	295	385	485	650	760	925	1 200	1 500
		med	175	220	270	335	495	590	735	1 020	1 210
		min	105	145	235	265	315	415	535	655	830
Sound power level [dB(A)]		max	45	47	49	47	48	52	56	60	64
		med	39	40	40	39	41	46	51	56	58
		min	32	30	36	33	31	37	42	45	50
Sound pressure level [dB(A)]	(3)	max	36	38	40	38	39	43	47	51	55
		med	30	31	31	30	32	37	42	47	49
		min	23	21	27	24	22	28	33	36	41
Power supply [V-ph-Hz]		230 / 1 / 50 + E									
Power input [W]	max	33	40	49	57	61	88	103	130	176	
Absorbed current [A]	max	0.16	0.18	0.23	0.26	0.27	0.39	0.47	0.58	0.78	
Dimensions **	Height	mm	530	530	530	530	530	530	530	530	
	Width	mm	670	770	985	985	1 200	1 200	1 415	1 415	1 415
	Depth	mm	225	225	225	225	225	225	225	255	255

(1) Room temperature 27°C d.b., 19°C w.b. - Water temperature 7/12 °C.

(2) Room temperature 20°C - Water inlet temperature: 50°C - Water flow rate as for the cooling conditions.

(3) Sound pressure level in a 100 m² room, at 1,5 m distance and reverberating time of 0,5 s.

* Water flow values as Cooling, accordingly to the EUROVENT standards and UNI ENV 1397.

** Dimensions refer to the units with casing.

Data shown is for 4 row cooling version, 2 pipe system.

For performance of 3 row cooling version and/or 4 pipe system unit please contact your local Johnson Controls sales office.



Manufacturer reserves the rights to change specifications without prior notice.

ECM Technology



Running costs. Energy consumption. Life cycle.

These are 3 issues that are becoming more and more important in the choice of Fan Coil Units. With these criteria in mind, Johnson Controls offers the ECM range of FCU.

ECM technology comprises a **brushless motor** combined to a **dedicated electronic device** (inverter). In comparison to conventional units equipped with asynchronous three-speed motors, the fancoil and cassette units with brushless motors can obtain a considerable energy saving, by **reducing power consumption up to 70%**.

Air flow rate can be varied in continuous by means of a 0-10 V signal generated both by our controls or by independent controls systems. The continuous air flow control improves the **acoustic comfort** and allows a more punctual reply to the variation of the thermal loads, enhancing the **stability of ambient temperature**.

Technology

ECM technology consists of a brushless motor combined with an inverter managed by specific regulators. The controller uses a 0-10 VDC modulating signal to regulate the fan speed.

The brushless electric motor is composed of a rotor having permanent magnets, whose magnetic fields interact with the ones produced by the stator winding. The **transfer of current is no longer by mechanical commutator** (sliding contacts) **but by an electronic commutation system**: one electronic controller (inverter) powers the motor's stator and generates rotating magnetic fields, that in turn determine the rotor's speed.

Brushless motor develop much less heat than the traditional brushed motors and they have much lower mechanical resistance than the standard asynchronous maintenance. The absence of brushes eliminates also the main source of electromagnetic noise.

Features

- Brushless motor with inverter.
- 0-10VDC control signal.
- Low mechanical resistance and heat gain
- Continuous regulation of the fan speed.
- Specifically designed electronic and digital regulators, also for BMS systems.
- Possibility to manually set the desired three fan speeds (MIN/MED/MAX).
- Available for fan coil and cassette units.

Advantages (compared to traditional brushed motors)

- Energy saving: electrical absorption reduced up to 70%.
- Higher efficiency: possibility to adapt the air volume and the capacities accordingly to the actual room loads.
- Higher comfort: reduced variation of the temperature and relative humidity in the room.
- Extremely quiet operation.
- Reduced wear and higher reliability.
- Longer life expectancy of the motor.

Power consumption: YFCN versus YFCN-ECM (W/kW)

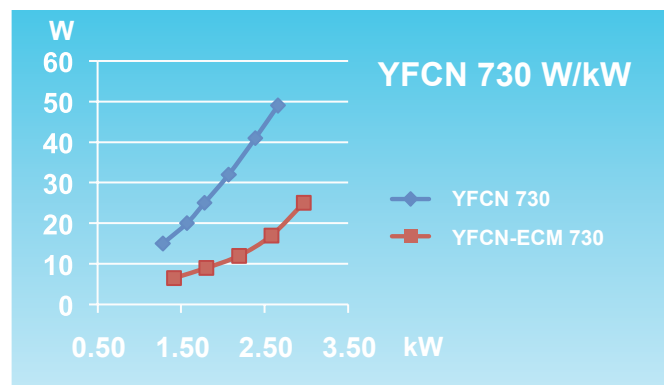
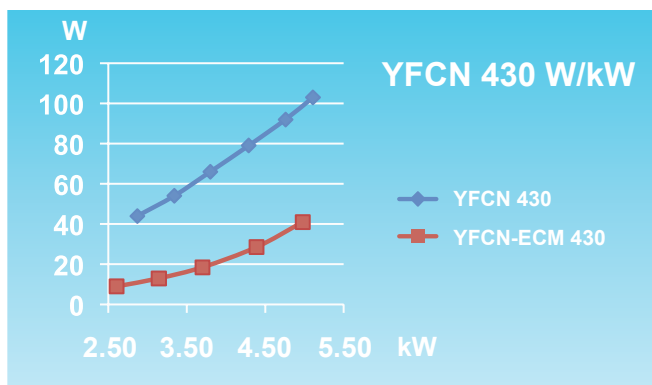

YFCN-ECM Fan Coil Unit Inverter with centrifugal fan

0.7 to 7.1 kW



Technical features

Model		230	240	430	440	630	640	730	740	930	940	
Total cooling capacity [kW]	(1)	max 10v	1.61	1.88	2.97	3.19	3.99	4.54	4.98	5.34	6.36	7.14
		med 5v	1.19	1.33	2.19	2.28	2.94	3.2	3.7	3.84	4.86	5.25
		min 1v	0.74	0.78	1.42	1.44	1.97	2.06	2.61	2.62	3.47	3.61
Sensible cooling capacity [kW]	(1)	max	1.3	1.44	2.28	2.41	3.11	3.41	3.84	4.03	5.2	5.63
		med	0.93	0.99	1.65	1.68	2.23	2.35	2.79	2.84	3.83	4.03
		min	0.56	0.57	1.04	1.04	1.47	1.49	1.93	1.91	2.65	2.71
Water flow in cooling [l/h]	(1)	max	277	323	511	549	686	781	857	918	1 094	1 228
		med	205	229	377	392	506	550	636	660	836	903
		min	127	134	244	248	339	354	449	451	597	621
Pressure drop in cooling [kPa]	(1)	max	8.6	14.8	28.9	16.1	19	33	32.6	25.6	25.9	20.8
		med	5	8	17	8.9	11.1	17.8	19.4	14.3	16.1	12.1
		min	2.2	3.2	7.9	4	5.5	8.2	10.5	7.3	8.9	6.3
Heating capacity 2 pipes [kW]	(2)	max	2.13	2.37	3.74	3.91	4.95	5.6	6.09	6.51	8.69	9.39
		med	1.53	1.63	2.7	2.75	3.59	3.87	4.47	4.61	6.41	6.7
		min	0.92	0.94	1.7	1.7	2.35	2.43	3.08	3.09	4.45	4.5
Water flow in heating 2 pipes [l/h] *	(2)	max	277	323	511	549	686	781	857	918	1 094	1 228
		med	205	229	377	392	506	550	636	660	836	903
		min	127	134	244	248	339	354	449	451	597	621
Pressure drop in heating 2 pipes [kPa]	(2)	max	8.3	12.6	23.9	13.5	15.7	26.9	26.8	21	22.5	17
		med	5.0	6.5	13.8	7.2	9.2	14.9	16.1	11.8	13.9	9.9
		min	2.0	2.6	6.6	3	4.5	6.5	8.4	6	7.7	5.2
Heating capacity 4 pipes [kW]	(3)	max	1.63	-	2.74	-	3.68	-	4.63	-	5.98	-
		med	1.23	-	2.11	-	2.8	-	3.56	-	4.62	-
		min	0.81	-	1.47	-	2	-	2.65	-	3.4	-
Water flow in heating 4 pipes [l/h]	(3)	max	140	-	236	-	317	-	398	-	514	-
		med	106	-	181	-	241	-	306	-	397	-
		min	70	-	126	-	172	-	228	-	292	-
Pressure drop in heating 4 pipes [kPa]	(3)	max	4.3	-	13.6	-	4.5	-	7.8	-	12.3	-
		med	2.6	-	8.5	-	2.8	-	4.9	-	7.8	-
		min	1.3	-	4.5	-	1.5	-	2.9	-	4.6	-
Air flow [m ³ /h]		max	330	325	515	505	735	720	890	875	1 395	1 365
		med	220	210	350	340	495	475	610	585	945	910
		min	120	115	210	200	305	290	400	380	605	575
Sound power level [dB(A)]		max	51	51	51	51	54	54	57	57	64	64
		med	41	41	42	42	44	44	48	48	55	55
		min	30	30	30	30	33	33	37	37	44	44
Sound pressure level [dB(A)]	(4)	max	42	42	42	42	45	45	48	48	55	55
		med	32	32	33	33	35	35	39	39	46	46
		min	21	21	21	21	24	24	28	28	35	35
Power supply [V-ph-Hz]		230 / 1 / 50 + E										
Power input [W]	max	21	21	25	25	32	32	41	41	99	99	
Absorbed current [A]	max	0.18	0.18	0.22	0.22	0.28	0.28	0.34	0.34	0.81	0.81	
Dimensions **	Height	mm	530	530	530	530	530	530	530	530	530	
	Width	mm	770	770	985	985	1 200	1 200	1 415	1 415	1 415	
	Depth	mm	225	225	225	225	225	225	225	225	255	

(1) Room temperature 27°C d.b., 19°C w.b. - Water temperature 7/12 °C

(2) Room temperature 20°C - Water inlet temperature: 50°C - Water flow rate as for the cooling conditions.

(3) Room temperature 20°C - Water inlet temperature: 70/60°C

(4) Sound pressure level in a 100 m² room, at 1,5 m distance and reverberating time of 0,5 s.

* Water flow values as Cooling, accordingly to the EUROVENT standards and UNI ENV 1397 ** Dimensions refer to the units with casing



Manufacturer reserves the rights to change specifications without prior notice.

Options / Accessories

Compatibility table / Codes

Model	YFCN AC motor + Standard control devices		
	VC/VCB mod. - Vertical with casing	HC mod. - Horizontal with casing	CD mod. - Without casing
Controls for style VC (supplied with separate packaging)			
Three speed control BL (1)	9060130	-	-
Three speed control + electronic thermostat and S/W switch TMV-S (2)	9060140	-	-
Three speed control + electronic thermostat and centralized S/W - TLC (2)	9060133	-	-
Automatic speed control with electronic thermostat and S/W switch ATL (2)	9066139	-	-
Controls for style HC/CD (supplied with separate packaging)			
Remote three speed control JWC-3V (1) (5)	-	9066642	9066642
Remote three speed control + electronic thermostat JWC-T and manual S/W switch (2)	-	9066630K	9066630K
Remote three speed control + electronic thermostat and centralized/manual S/W switch JWC-TQR (2) (4)	-	9066631K	9066631K
Automatic speed control with electronic thermostat and S/W switch - JWC-AU (to be used with JPF-AU and JP-AU only) (2) (4)	-	9066632K	9066632K
Automatic remote control with electronic thermostat, S/W switch and liquid crystal display JTM-B (to be used with JPF-AU and JP-AU only) (2) (4)	-	9066331E	9066331E
Automatic speed control with electronic thermostat to be mounted in the light wall box TMO-503-SV2 (3) (5)	-	9060172	9060172
Electromechanical thermostat T2T (5) (6)	-	9060174	9060174
Power unit JPF-AU for JWC-AU and JTM-B remote controls, fitted on the unit	9066641	9066641	9066641
Power unit JP-AU for JWC-AU and JTM-B remote controls, not fitted on the unit	9066640	9066640	9066640
Controls accessories for all versions (supplied with separate packaging)			
Low temperature cut-out for controls TLC	3021091	3021091	3021091
Low temperature cut-out for controls TMV-S and JWC-T	9053048	9053048	9053048
Low temperature cut-out for controls ATL, JWC-TQR, JWC-AU and JTM-B	3021090	3021090	9053049
T2 sensor to be used as Change-over for controls ATL, JWC-AU and JTM-B	9025310	9025310	9025310
Change-over 15-25 for control TLC and JWC-TQR	9053049	9053049	9053049
Receiving speed selector for centralized control (slave) style VC RECV	9060136	9060136	9060136
Receiving speed selector for centralized control (slave) style HC/CD SEL-CR	9066311	9066311	9066311
Terminal board adaptor kit KIT	9060103	-	-
Controls for style VC + additional electric resistance (supplied with separate packaging)			
Three speed control with electronic thermostat and S/W switch TMV-R-IAQ	9063006	-	-
Automatic speed control with electronic thermostat and S/W switch JWC-AU (2)	9066632K	-	-
Controls for style HC/CD + additional electric resistance (supplied with separate packaging)			
Remote three speed control + electronic thermostat and centralized/manual S/W switch JWC-TQR (3)	-	9066631K	9066631K
Automatic speed control with electronic thermostat and centralized S/W - JWC-AU (3)	-	9066632K	9066632K
Automatic remote control with electronic thermostat, S/W switch and liquid crystal display JTM-B (2)	-	9066331E	9066331E
WARNING			
(1) Not to be used with valves and/or low temperature cut-out. (2) It can be used with valves and/or low temperature cut-out. (3) Low temperature cut-out included. (4) It can be used with Change Over. (5) Not suitable with -E electric heater. (6) Not to be used with low temperature cut-out.			
Free wireless control system for all YFCN all versions			
Remote Control FREE-COM	9060572	9060572	9060572
Mounted Electronic Board FREE-UPM	9060571	9060571	9060571
Not Mounted Electronic Board FREE-UPS	9060570	9060570	9060570
Temperature sensor FREE-SEN	9060573	9060573	9060573

Options / Accessories

Compatibility table / Codes

Model	YFCN AC motor + MB control devices
Versions	ALL VERSIONS: VC/VCB - Vertical w. casing + HC - Horizontal with casing + CD without casing ALL VERSIONS: VC/VCB + HC + CD with electric heater
Controls and accessories for all versions	
Mounted power unit MB-M	9066332
Not mounted power unit MB-S	9066333
Wall control JTM-B	9066331E
IR remote control and mounted IR receiver RM-RT03	9066336
IR remote control and not mounted IR receiver RS-RT03	9066337
IR remote control RT03	3021203
Mounted IR receiver RM	9066339
Not mounted IR receiver RS	9066338
Multifunction wall control up to 60 units PSM-DI	3021293
T2 sensor (to be used as Change-over or minimum temp. Sensor)	9025310
Management system for a network of fan coils with MB electronic board	
Hardware/software supervisory system (to be used with MB board only) NET	9079118
Router-S	3021290
Relay output board SIOS	3021292

With T-MB wall control

One control for each unit
(Maximum length of the connection cable = 20 m)



One control for more units (20 units max.)
(Maximum total length of the connection cable = 800 m)



With RT03 Infra-red remote control

One control for each unit



One control for more units (20 units max.)
(Maximum total length of the connection cable = 800 m)



Options / Accessories

Compatibility table / Codes

Model	YFCN ECM motor + Standard control devices		
Versions	VC/VCB mod. - Vertical with casing	HC mod. - Horizontal with casing	CD mod. - Without casing
Controls accessories for all versions (supplied with separate packaging)			
Low temperature cut out NTC for control TMV-T-ECM, WM-S-ECM and JP-AU power unit		3021090	
T2 sensor to be used as Change-over for JP-AU power unit		9025310	
Change over 15-25 CH 15-25 for control TMV-T-ECM		9053049	
Model	YFCN ECM motor + MB control devices		
Versions	VC/VCB mod. - Vertical with casing	HC mod. - Horizontal with casing	CD mod. - Without casing
Controls for style VC (supplied with separate packaging)			
Continuous fan speed control with electronic thermostat and S/W switch TMV-T-ECM	9060141	-	-
Controls for style HC/CD (supplied with separate packaging)			
JWC-AU Automatic speed control with electronic thermostat and centralized S/W switch	-	9066632K	9066632K
JTM-B Automatic remote control with electronic thermostat, S/W switch and liquid crystall display	-	9066331E	9066331E
WM-S-ECM Continuous fan speed control with S/W switch and liquid crystall display	-	9066644	9066644
JPF-AU power unit for JWC-AU and JTM-AU remote controls, fitted on the unit	9066641	9066641	9066641
JP-AU power unit for JWC-AU and JTM-AU remote controls, not fitted on the unit	9066640	9066640	9066640
Accessories of controls for VC, HC-VCB and CD models (supplied with separate packaging)			
MB-ECM-M mounted power unit for ECM fan coil	9066334	9066334	9066334
MB-ECM-S not mounted power unit for ECM fan coil	9066335	9066335	9066335
Wall control JTM-B	9066331E	9066331E	9066331E
IR remote control and mounted IR receiver RM-RT03	9066336	9066336	9066336
IR remote control and not mounted IR receiver RS-RT03	9066337	9066337	9066337
IR remote control RT03	3021203	3021203	3021203
Mounted IR receiver RM	9066339	9066339	9066339
Not mounted IR receiver RS	9066338	9066338	9066338
Multifunction wall control up to 60 units PSM-DI	3021293	3021293	3021293
T2 sensor (to be used as Change-over or minimum temperature Sensor)	9025310	9025310	9025310
Management system for a network of fan coils with MB electronic board			
Hardware / software supervisory system Net	9079118	9079118	9079118
Router S	3021290	3021290	3021290
Relay output board SIOS	3021292	3021292	3021292

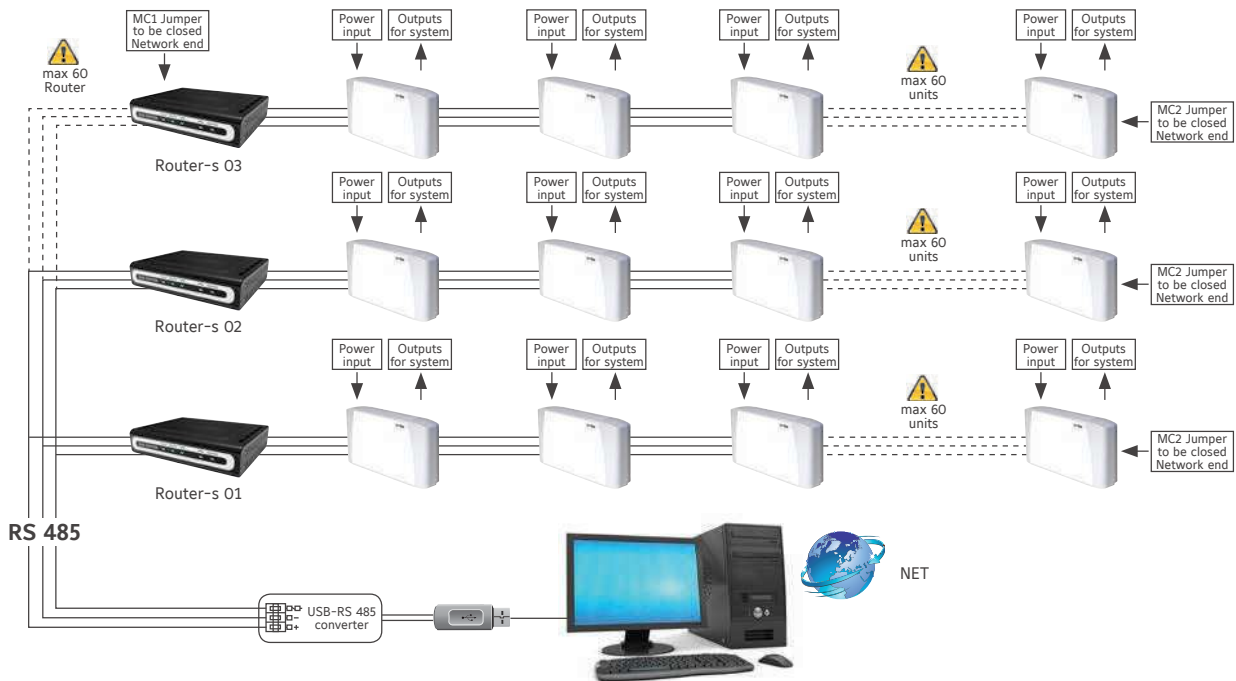

Options / Accessories

Compatibility table / Codes

Model	YFCN General accessories								
	130/140	230/240	330/340	430/440	530/540	630/640	730/740	830/840	930/940
Valves all versions									
3 way double valve kit for 4 tube installation and single coil + kit fitted on the unit					9066572W				
3 way double valve kit for 4 tube installation and single coil + kit not fitted on the unit					9066562W				
Kit 3 way valve mounted			9066561					9060471	
Kit 3 way valve additional battery mounted					9060472				
Kit 3 way valve not mounted			9066560					9060474	
Kit 3 way valve additional battery not mounted					9060475				
Kit 2 way valve primary and/or additional battery mounted			9060476					-	
Kit 2 way valve primary battery mounted			-					9060477	
Kit 2 way valve primary and/or additional battery not mounted			9060478					-	
Kit 2 way valve primary battery not mounted			-					9060479	
2 way DN 10 balance valve for main coil + kit fitted on the unit		9066660				-			
2 way DN 15 balance valve for main coil + kit fitted on the unit		-			9066661			-	
2 way DN 20 balance valve for main coil + kit fitted on the unit				-				9066662	
2 way DN 10 balance valve for additional coil + kit fitted on the unit			9066663					-	
2 way DN 15 balance valve for additional coil + kit fitted on the unit			-					9066664	
2 way DN 10 balance valve for main coil + kit not fitted on the unit		9066650				-			
2 way DN 15 balance valve for main coil + kit not fitted on the unit		-			9066651			-	
2 way DN 20 balance valve for main coil + kit not fitted on the unit				-				9066652	
2 way DN 10 balance valve for additional coil + kit not fitted on the unit			9066653					-	
2 way DN 15 balance valve for additional coil + kit not fitted on the unit			-					9066654	
Valves CD versions only									
	130/140	230/240	330/340	430/440	530/540	630/640	730/740	830/840	930/940
Simplified 3-way valve kit for CD version fitted			9066571					9060484	
Simplified 3-way valve kit for CD version not fitted			9066570					9060481	
Simplified 3-way valve kit for CD version not fitted - additional battery					9060480				
Electric heater VC/VCB/CH version									
	130/140	230/240	330/340	430/440	530/540	630/640	730/740	830/840	930/940
El. resistance and relays fitted on the unit (650 W) VC/HC	9066491E					-			
El. resistance and relays fitted on the unit (400 W) VC/HC	-	9066472E				-			
El. resistance and relays fitted on the unit (600 W) VC/HC	-	9066482E	9066473E				-		
El. resistance and relays fitted on the unit (750 W) VC/HC			-		9066475E			-	
El. resistance and relays fitted on the unit (900 W) VC/HC		-	9066483E				-		
El. resistance and relays fitted on the unit (1000 W) VC/HC	-	9066492E						9066477E	
El. resistance and relays fitted on the unit (1250 W) VC/HC			-		9066485E			-	
El. resistance and relays fitted on the unit (1500 W) VC/HC		-	9066493E					9066487E	
El. resistance and relays fitted on the unit (2000 W) VC/HC			-		9066495E			-	
El. resistance and relays fitted on the unit (2500 W) VC/HC				-				9066497E	
Electric heater CD version									
	130/140	230/240	330/340	430/440	530/540	630/640	730/740	830/840	930/940
El. resistance and relays fitted on the unit (700 W) CD	9066611					-			
El. resistance and relays fitted on the unit (400 W) CD	-	9066592				-			
El. resistance and relays fitted on the unit (600 W) CD	-	9066602	9066593				-		
El. resistance and relays fitted on the unit (750 W) CD			-		9066595			-	
El. resistance and relays fitted on the unit (900 W) CD			9066603				-		
El. resistance and relays fitted on the unit (1000 W) CD	-	9066612						9066597	
El. resistance and relays fitted on the unit (1250 W) CD			-		9066605			-	
El. resistance and relays fitted on the unit (1500 W) CD		-	9066613					9066607	
El. resistance and relays fitted on the unit (2000 W) CD			-		9066615			-	
El. resistance and relays fitted on the unit (2500 W) CD				-				9066617	

Options / Accessories

Compatibility table / Codes

Model	YFCN General accessories								
	130/140	230/240	330/340	430/440	530/540	630/640	730/740	830/840	930/940
Accessories for all versions	130/140	230/240	330/340	430/440	530/540	630/640	730/740	830/840	930/940
Pair feet	9060150						9060151		
Vertical auxiliary condensate tray					6060400				
Horizontal auxiliary condensate tray (left connections)					6060402				
Horizontal auxiliary condensate tray (right connections)					6060403				
Condensate pump for VC - VCB - CD fitted on the unit auxiliary condensate collection tray included (vertical installation)					9066297				
Condensate pump for VC - VCB - CD not fitted on the unit auxiliary condensate collection tray included (vertical installation)					9066296				
Condensate pump for CD fitted on the unit auxiliary condensate collection tray to be ordered separately (horizontal installation)					9066295				
Condensate drain pipe	6060420								
Damper	9066531	9066532	9066533		9066535		9066537	9066538	
Kit breeze	-	9076452	9076453		9076455		-		
Recessed box	-	9076462	9076463		9076465		-		
Rear closing panel VC	9062005	9060180	9060181		9060182		9060183		
Rear closing panel HC	9060187	9060190	9060191		9060192		9060193	9060194	
Frontal air intake CD mounted	9066501	9066502	9066503		9066505		9066507	9066508	
Intake grid for VC	9060229	9060230	9060231		9060232		9060233		
Adaptor for terminal board VC for remote control	9060103								
Accessories only for concealed version CD	130/140	230/240	330/340	430/440	530/540	630/640	730/740	830/840	930/940
Outlet flange 90° FM90	9066381	9066382	9066383		9066385		9066387	9066388	
Inlet flange 90° FR90	9066441	9060710	9060711		9060712		9060713	9060714	
Straight inlet flange FRD	9066451	9060720	9060721		9060722		9060723	9060724	
Straight outlet flange FMD	9066371	9066372	9066373		9066375		9066377	9066378	
Outlet spigot diffuser PMC	9066361	9066362	9066363		9066365		9066367	9066368	
Air outlet grid BMA	9066411	9060750	9060751		9060752		9060753		
Air inlet grid GRAG	9066431	9060764	9060765		9060766		9060767		
Air inlet grid GRAP	9066421	9060760	9060761		9060762		9060763		
Air inlet spigot plenum PRC	9066461	9066462	9066463		9066465		9066467	9066468	
Intake grid with filter (to be used in combination with inlet flange 90°) GRAFP	9066391	9060770	9060771		9060772		9060773		
Intake grid with filter (to be used in combination with straight inlet flange) GRAFG	9066401	9060774	9060775		9060776		9060777		

Dimensions

YFCN / YFCN-ECM 130 to 940 (with casing)



VC, VCB and HC models

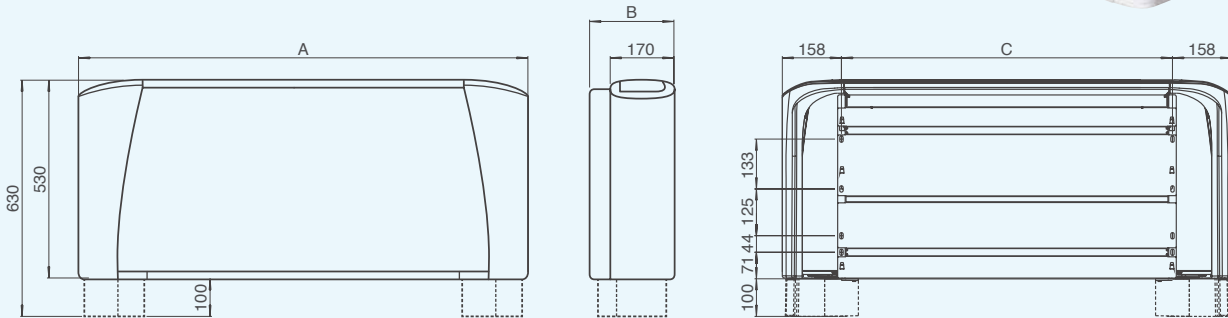

All dimensions in mm. Drawings not a scale.

Model	130 / 140	230 / 240	330 / 340	430 / 440	530 / 540	630 / 640	730 / 740	830 / 840	930 / 940
A	670	770	985	985	1 200	1 200	1 415	1 415	1 415
B	225	225	225	225	225	225	225	255	255
C	354	454	669	669	884	884	1 099	1 099	1 099

YFCN / YFCN-ECM 130 to 940 (without casing)



CD models

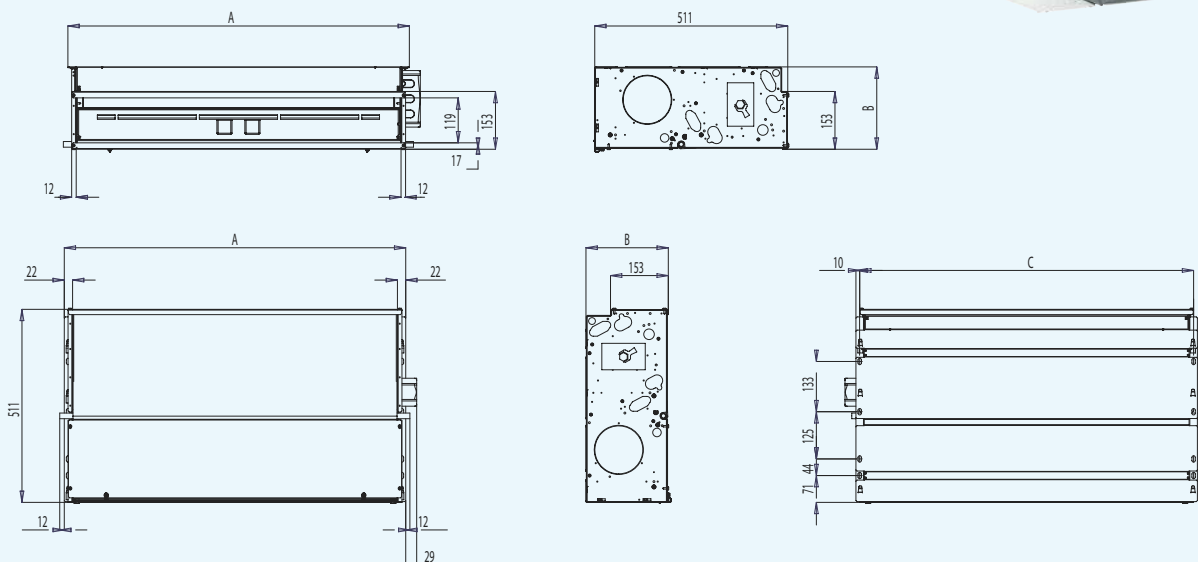

All dimensions in mm. Drawings not a scale.

Model	130 / 140	230 / 240	330 / 340	430 / 440	530 / 540	630 / 640	730 / 740	830 / 840	930 / 940
A	374	474	689	689	904	904	1 119	1 119	1 119
B	218	218	218	218	218	218	218	248	248
C	354	454	669	669	884	884	1 099	1 099	1 099

LASER & LOW BODY Fan Coil Units

2 & 4 pipe system

A complete range from 0.7 kW up to 9.95 kW



TUC03 Terminal unit controller
BacNET and N2 Metasys network compatible



CSL00 (Built in)
CSR00 (Wall mounted)
Fan speed selector



CEL00 (Built in)
CER00 (Wall mounted)
Thermostat with manual fan speed and automatic change over



CML00 (Built in)
CMR00 (Wall mounted)
Thermostat with manual fan speed and S/W change over

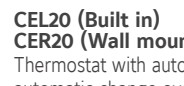

CEL20 (Built in)
CER20 (Wall mounted)
Thermostat with auto. fan speed and automatic change over

CEL30 (Built in)
CER30 (Wall mounted)
Thermostat with auto. fan speed and automatic change over for modulating valve

LASER fan coil units are simple and elegant, discreet in their design. High standards of quality and reliability, combined with a wide range of accessories ensure a total solution for all comfort cooling and heating requirements.

LOW BODY units are part of the LASER Fan Coils Units family. The reduced height cabinet makes them the ideal solution for new or replacement applications where dimensional limitations apply.

Features

- 6 speed fan
- Cabinet factory fitted
- Valve factory fitted
- Electrical heater factory fitted
- Thermal or modulating valve
- Service valve
- Option front air intake (LASER)
- Optional plenum (LASER)
- ECM inverter option available



Selection software

LASER & LOW BODY Fan Coil Units

0.7 to 9.95 kW



Technical features

Model		LASER: YLV, YLV-AF, YLH, YLH-AF, YLIV, YLIV-AF, YLIH, YLIH-AF										
Sizes		110	112	114	216	218	220	222	224	226	328	
Total cooling capacity [kW]	(1)	max	1.16	1.64	2.21	3.36	3.58	4.53	5.19	6.57	7.41	9.95
		med	0.99	1.35	1.92	2.72	3.05	3.75	4.48	5.87	6.81	8.95
		min	0.79	1.1	1.61	2.24	2.5	2.99	3.91	4.7	5.61	6.51
Sensible cooling capacity [kW]	(1)	max	0.98	1.37	1.96	2.52	3.14	3.62	4.54	5.2	5.86	8.27
		med	0.82	1.09	1.68	2.00	2.57	2.91	3.83	4.56	5.32	7.34
		min	0.64	0.86	1.36	1.60	2.04	2.25	3.27	3.53	4.26	5.18
Water flow in cooling [l/h]	(1)	max	201	300	394	596	654	802	958	1167	1306	1657
		med	173	244	345	487	553	687	863	1074	1224	1491
		min	140	197	284	398	452	567	741	842	977	1084
Pressure drop in cooling [kPa]	(1)	max	3.4	7.1	5.8	14.8	13.6	24.1	28.4	18.8	21	34.2
		med	2.8	5	4.6	12.5	9.8	17.4	21.8	15.5	18.1	28.2
		min	2	3.4	3.3	8.5	6.7	11.6	17.2	10.5	12.8	14.1
Heating capacity 2 pipes [kW]	(2)	max	1.57	2.16	3.05	4.11	4.95	5.71	7.19	7.83	9.33	12.96
		med	1.28	1.73	2.43	3.44	4.16	4.65	6.08	6.94	8.51	11.43
		min	1	1.35	2	2.75	3.35	3.61	5.25	5.45	6.86	8.02
Water flow in heating 2 pipes [l/h]	(2)	max	Water flow values as Cooling, accordingly to the EUROVENT standards and UNI ENV 1397									
		med										
		min										
Pressure drop in heating 2 pipes [kPa]	(2)	max	2.7	6.1	4.8	11.9	12.5	20	23.5	15.5	20.5	30.4
		med	2.3	4.7	3.7	8.5	9.1	14.3	18	12.7	17.6	24.9
		min	1.7	3.1	2.8	5.7	6.3	9.5	14.2	8.7	12.4	13.8
Heating capacity 4 pipes [kW]	(3)	max	1.12	1.46	2.25	3.10	3.64	4.92	5.53	6.92	7.18	9.10
		med	1.02	1.31	2.06	2.73	3.19	4.16	4.92	6.3	6.8	8.34
		min	0.79	1.1	1.68	2.29	2.7	3.38	4.36	5.16	5.71	6.60
Water flow in heating 4 pipes [l/h]	(3)	max	100	163	199	307	346	445	499	608	642	756
		med	86	134	176	259	294	382	449	562	604	693
		min	71	110	147	214	241	318	386	448	489	548
Pressure drop in heating 4 pipes [kPa]	(3)	max	2	4.4	8.83	19.3	9.0	13	14.5	40.6	40	58.6
		med	1.6	3.4	7	15.2	7.1	9.7	11.9	28.8	36.4	49.9
		min	1.07	2.4	6.27	11.4	5.0	6.7	9.6	20.3	26.8	31.9
Air flow [m3/h]	(3)	max	243	321	436	581	712	871	1081	1254	1481	2068
		med	192	249	358	456	592	699	929	1116	1352	1725
		min	143	194	289	338	474	538	739	798	999	1070
Sound power level [dB(A)]	(3)	max	48	50	54	53	55	54	60	60	63	67
		med	42	45	49	47	50	48	56	56	60	63
		min	36	38	42	40	43	41	50	47	53	52
Sound pressure level [dB(A)]	(4)	max	38	40	42	41	43	41	47	45	50	61
		med	33	35	38	36	39	35	42	44	47	57
		min	28	29	32	29	32	29	38	37	41	46
Power supply [V-ph-Hz]		230 / 1 / 50 + E										
Power input [W]	max	46	48	57	61	86	90	117	140	162	213	
Absorbed current [A]	max	0.22	0.23	0.27	0.29	0.33	0.38	0.52	0.65	0.65	1.00	
Dimensions	Height	mm	538	538	538	538	538	614	614	614	614	614
	Width	mm	648	773	898	1023	1148	1273	1273	1523	1523	1773
	Depth	mm	224	224	224	224	224	254	254	254	254	254

(1) Room temperature 27°C d.b., 19°C w.b. - Water temperature 7/12 °C
 (2) Room temperature 20°C - Water inlet temperature: 50°C
 (3) Room temperature 20°C - Water inlet temperature: 70/60°C.
 (4) Sound pressure level in a 100 m³ room, at 1.5 m distance and reverberating time of 0.3 s.
 max = speed 2, med = speed 3 min = speed 5 when using selection software



Manufacturer reserves the rights to change specifications without prior notice.

LASER & LOW BODY Fan Coil Units

0.7 to 9.95 kW



Technical features

Model		LOW BODY: YLVR, YLIVR					
Sizes		110	112	114	216	218	
Total cooling capacity [kW]	(1)	max	0.94	1.46	2.11	2.72	3.37
		med	0.84	1.22	1.77	2.37	2.95
		min	0.69	0.97	1.42	1.95	2.58
Sensible cooling capacity [kW]	(1)	max	0.83	1.19	1.69	2.16	2.64
		med	0.72	0.97	1.38	1.86	2.29
		min	0.57	0.75	1.09	1.5	1.97
Water flow in cooling [l/h]	(1)	max	162	251	364	467	580
		med	145	211	305	409	509
		min	119	168	246	336	444
Pressure drop in cooling [kPa]	(1)	max	2.1	4	12.6	6.9	18.4
		med	1.7	2.9	9.3	5.5	14.6
		min	1.2	1.9	6.3	3.9	11.5
Heating capacity 2 pipes [kW]	(2)	max	1.39	2.01	2.83	3.64	4.43
		med	1.23	1.69	2.32	3.13	3.83
		min	0.98	1.28	1.83	2.52	3.30
Water flow in heating 2 pipes [l/h]	(2)	max	Water flow values as Cooling, accordingly to the EUROVENT standards and UNI ENV 1397				
		med					
		min					
Pressure drop in heating 2 pipes [kPa]	(2)	max	1.7	3.2	4.3	5.6	14.9
		med	1.4	2.4	3	4.4	11.9
		min	1.0	1.6	2	3.1	9.3
Heating capacity 4 pipes [kW]	(3)	max	1.15	1.83	2.43	3.27	3.65
		med	1.02	1.53	2.03	2.85	3.2
		min	0.83	1.22	1.64	2.34	2.8
Water flow in heating 4 pipes [l/h]	(3)	max	101	161	213	286	320
		med	90	134	177	250	280
		min	73	107	144	205	245
Pressure drop in heating 4 pipes [kPa]	(3)	max	2.2	4.6	10.5	18.9	5.7
		med	1.7	3.3	7.6	14.9	4.5
		min	1.2	2.2	5.2	10.5	3.6
Air flow [m ³ /h]		max	243	321	446	574	691
		med	203	246	343	470	570
		min	149	178	253	356	470
Sound power level [dB(A)]		max	50	51	54	54	56
		med	44	46	49	48	51
		min	37	39	43	41	44
Sound pressure level [dB(A)]	(4)	max	40	41	44	44	46
		med	34	36	39	38	41
		min	27	29	33	31	34
Power supply [V-ph-Hz]		230 / 1 / 50 + E					
Power input [W]	max	46	48	57	81	86	
Absorbed current [A]	max	0.22	0.23	0.28	0.39	0.42	
Dimensions	Height	mm	430	430	430	430	430
	Width	mm	648	773	898	1023	1148
	Depth	mm	254	254	254	254	224

(1) Room temperature 27°C d.b., 19°C w.b. - Water temperature 7/12 °C

(2) Room temperature 20°C - Water inlet temperature: 50°C

(3) Room temperature 20°C - Water inlet temperature: 70/60°C.

(4) Sound pressure level in a 100 m³ room, at 1.5 m distance and reverberating time of 0.3 s.
max = speed 2, med = speed 3 min = speed 5 when using selection software



Manufacturer reserves the rights to change specifications without prior notice.

Options / Accessories

Compatibility table / Codes

Model	Sizes	LASER										LOW BODY				
		110	112	114	216	218	220	222	224	226	228	110	112	114	216	218
With Cabinet																
YLV-YLH	2/3/4 rows	•	•	•	•	•	•	•	•	•	•	•	•			
YLV-YLH/AF Front air intake	2/3/4 rows	•	•	•	•	•	•	•	•	•	•	•	•			
YLVR	2/3 rows												•	•	•	•
Without Cabinet																
YLIV-YLIH	2/3/4 rows	•	•	•	•	•	•	•	•	•	•	•	•			
YLIV-YLIH/AF Front air intake	2/3/4 rows	•	•	•	•	•	•	•	•	•	•	•	•			
YLIVR	2/3 rows												•	•	•	•
Options (Factory fitted)																
Coil and heaters																
1 row heating	BA1	•	•	•	•	•	•	•	•	•	•	•	•	•	•	•
Kit electrical heater (with relay and safety switch)	KREL	•	•	•	•	•	•	•	•	•	•	•	•	•	•	•
Built in thermostat																
Fan speed selector	CSL00															
Thermostat with manual fan speed and S/W change over	CML00															
Thermostat with manual fan speed, dead band, automatic change over	CEL00															
Thermostat with automatic fan speed, dead band, automatic change over	CEL20															
Thermostat with automatic fan speed, dead band, automatic change over for modulating valve	CEL30															
Parallel connection																
For ON/OFF valve one/FCU	CBL20															
For modulating valve one/FCU	CBL30															
3 way valve factory fitted																
For 2 pipe systems ON/OFF	J3A2 (2p)															
For 4 pipe systems ON/OFF	J3A2 (4p)															
3 way modulating valve factory fitted																
For 2 pipe systems Modulating	J3AM (2p)															
For 4 pipe systems Modulating	J3AM (4p)															
Shut off valves factory fitted																
For 2 pipe systems	DT (2p)															
For 4 pipe systems	DT (4p)															
Condensate pump	PC															
WS sensor change over for CEL/CER	WS															
Minimum temperature thermostat	TM															
Accessories (Supplied loose)																
Remote controllers and thermostat (wall mounted)																
Fan speed selector	CSR00															
Thermostat with manual fan speed and S/W change over	CMR00															
Thermostat with manual fan speed, dead band, automatic change over	CER00															
Thermostat with automatic fan speed, dead band, automatic change over	CER20															
Thermostat with automatic fan speed, dead band, automatic change over for modulating valve	CER30															
Feet and panel (1)																
Set of painted feet	CP1	•	•	•	•	•	•	•	•	•	•	•	•	•	•	•
Set of painted feet + frontal socle	ZL1	•	•	•	•	•	•	•	•	•	•	•	•	•	•	•
Vertical painted back panel	PPV1	•	•	•	•	•	•	•	•	•	•	•	•	•	•	•
Horizontal painted back panel	PPH1	•	•	•	•	•	•	•	•	•	•	•	•	•	•	•
Plenums and air intake (1)																
Air intake plenum	PA	•	•	•	•	•	•	•	•	•	•	•	•	•	•	•
Air intake plenum with collars	PAS	•	•	•	•	•	•	•	•	•	•	•	•	•	•	•
90° air intake plenum	PA90	•	•	•	•	•	•	•	•	•	•	•	•	•	•	•
Air intake duct fitting	RCA	•	•	•	•	•	•	•	•	•	•	•	•	•	•	•
Air delivery plenum with collars	PM	•	•	•	•	•	•	•	•	•	•	•	•	•	•	•
90° air delivery plenum	PM90	•	•	•	•	•	•	•	•	•	•	•	•	•	•	•

(1) for check compatibility with the models of FCU see compatibility table

Dimensions & Weights

YLV & YLH

- ▶ V= vertical
- ▶ H= horizontal

YLV-AF & YLH-AF

- ▶ AF= front air intake
- ▶ V= vertical
- ▶ H= horizontal

YLV-R

- ▶ R= low body
- ▶ V= vertical

LASER: YLV - YLV/AF

VERTICAL

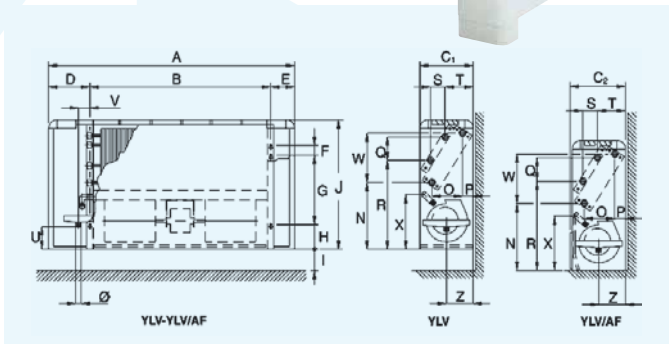

LASER: YLH - YLH/AF

HORIZONTAL

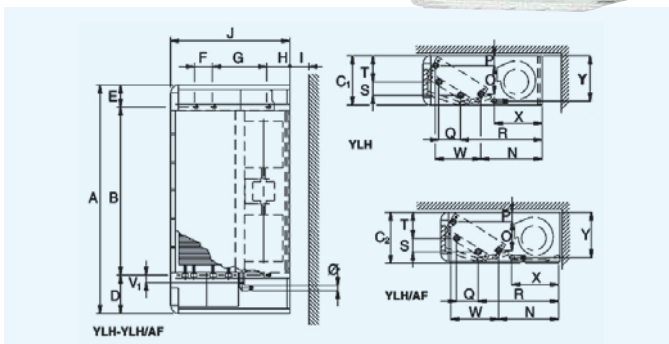

Dim	110	112	114	216	218	220	222	224	226	328
A	648	773	898	1023	1148	1273	1273	1523	1523	1773
B	374	499	624	749	874	999	999	1249	1249	1499
C1	224	224	224	224	224	254	254	254	254	254
C2	233	233	233	233	233	263	263	263	263	263
D	174	174	174	174	174	174	174	174	174	174
E	100	100	100	100	100	100	100	100	100	100
F	40	40	40	40	40	40	40	40	40	40
G	280	280	280	280	280	356	356	356	356	356
H	101	101	101	101	101	101	101	101	101	101
I	85	85	85	85	85	85	85	85	85	85
J	538	538	538	538	538	614	614	614	614	614
N	266	266	266	266	266	299	299	299	299	299
O	113	113	113	113	113	138	138	138	138	138
P	48	48	48	48	48	53	53	53	53	53
Q	87	87	87	87	87	87	87	87	87	87
R	355	355	355	355	355	409	409	409	409	409
S	50	50	50	50	50	50	50	50	50	50
T	117	117	117	117	117	135	135	135	135	135
U	90	90	90	90	90	116	116	116	116	116
V	47	47	47	47	47	47	47	47	47	47
V 1	28	28	28	28	28	28	28	28	28	28
W	195	195	195	195	195	238	238	238	238	238
X	219	219	219	219	219	252	252	252	252	252
Y	205	205	205	205	205	235	235	235	235	235
Z	109	109	109	109	109	122	122	122	122	122
Ø	20	20	20	20	20	20	20	20	20	20
kg1	18	20	23	28	31	41	44	52	52	58
kg2	19	21	24	30	32	43	46	54	54	61

Notes: 1=YLV / YLH - 2=YLV/AF / YLH/AF (All dimensions in mm)

LOW BODY: YLVR

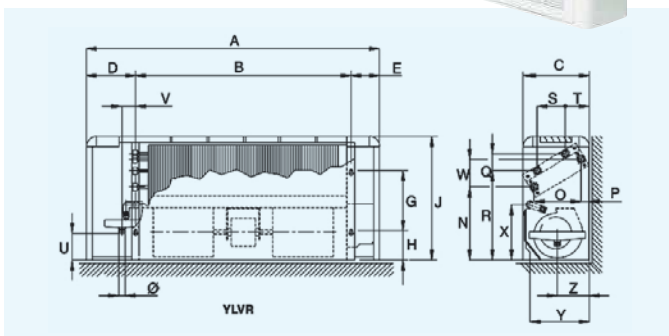

Dim	110	112	114	216	218
A	648	773	898	1023	1148
B	374	499	624	749	874
C	254	254	254	254	254
D	174	174	174	174	174
E	100	100	100	100	100
G	170	170	170	170	170
H	101	101	101	101	101
J	430	430	430	430	430
N	245	245	245	245	245
O	154	154	154	154	154
P	31	31	31	31	31
Q	47	47	47	47	47
R	304	304	304	304	304
S	88	88	88	88	88
T	87	87	87	87	87
U	65	65	65	65	65
V	47	47	47	47	47
W	84	84	84	84	84
X	214	214	214	214	214
Z	109	109	109	109	109
Ø	20	20	20	20	20
kg	15	17	22	23	26

(All dimensions in mm)

Dimensions & Weights

- | YLIV & YLIH | YLIV-AF & YLIH-AF | YLIVR |
|--|--|--|
| <ul style="list-style-type: none"> ▶ V= vertical ▶ H= horizontal ▶ l= without cabinet | <ul style="list-style-type: none"> ▶ AF= front air intake ▶ V= vertical ▶ H= horizontal ▶ l= without cabinet | <ul style="list-style-type: none"> ▶ R= low body ▶ V= vertical ▶ l= without cabinet |

LASER: YLIV - YLIV/AF

VERTICAL

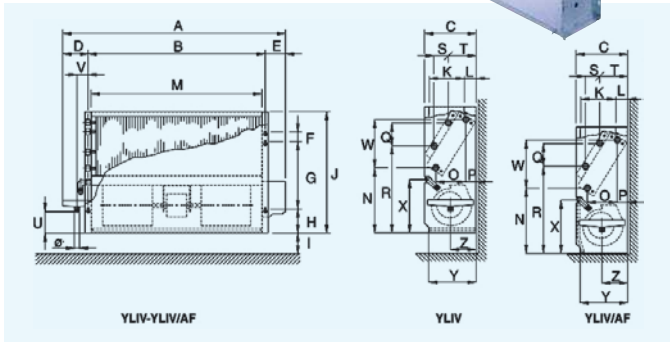

LASER: YLIH - YLIH/AF

HORIZONTAL

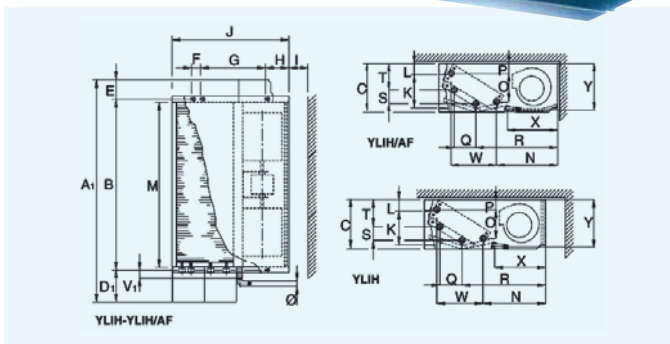

LOW BODY: YLIVR

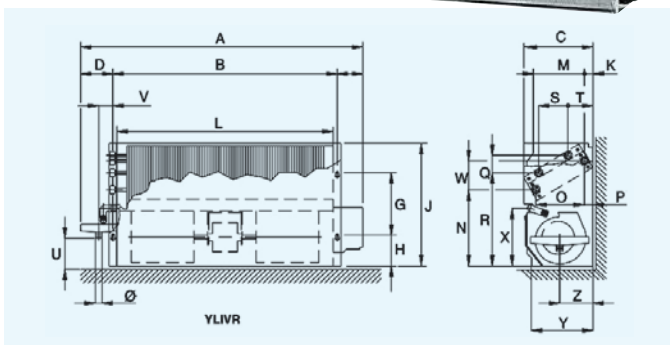

Dim	110	112	114	216	218	220	222	224	226	328
A	555	680	805	930	1055	1180	1180	1430	1430	1680
A 1	574	699	824	949	1074	1199	1199	1449	1449	1699
B	374	499	624	749	874	999	999	1249	1249	1499
C	215	215	215	215	215	245	245	245	245	245
D	109	109	109	109	109	109	109	109	109	109
D 1	128	128	128	128	128	128	128	128	128	128
E	72	72	72	72	72	72	72	72	72	72
F	40	40	40	40	40	40	40	40	40	40
G	280	280	280	280	280	356	356	356	356	356
H	101	101	101	101	101	101	101	101	101	101
I	85	85	85	85	85	85	85	85	85	85
J	505	505	505	505	505	581	581	581	581	581
K	110	110	110	110	110	125	125	125	125	125
L	55	55	55	55	55	60	60	60	60	60
M	349	474	599	724	849	974	974	1224	1224	1474
N	266	266	266	266	266	299	299	299	299	299
O	113	113	113	113	113	138	138	138	138	138
P	48	48	48	48	48	53	53	53	53	53
Q	87	87	87	87	87	87	87	87	87	87
R	355	355	355	355	355	409	409	409	409	409
S	50	50	50	50	50	50	50	50	50	50
T	117	117	117	117	117	135	135	135	135	135
U	90	90	90	90	90	116	116	116	116	116
V	47	47	47	47	47	47	47	47	47	47
V 1	28	28	28	28	28	28	28	28	28	28
W	195	195	195	195	195	238	238	238	238	238
X	219	219	219	219	219	252	252	252	252	252
Y	200	200	200	200	200	230	230	230	230	230
Z	109	109	109	109	109	122	122	122	122	122
∅	20	20	20	20	20	20	20	20	20	20
kg	10	13	16	19	22	29	31	38	38	42

(All dimensions in mm)

Dim	110	112	114	216	218
A	555	680	805	930	1055
B	374	499	624	749	874
C	230	230	230	230	230
D	108	108	108	108	108
E	73	73	73	73	73
G	170	170	170	170	170
H	101	101	101	101	101
J	395	395	395	395	395
K	61	61	61	61	61
L	349	474	599	724	849
M	127	127	127	127	127
N	245	245	245	245	245
O	154	154	154	154	154
P	31	31	31	31	31
Q	47	47	47	47	47
R	304	304	304	304	304
S	88	88	88	88	88
T	87	87	87	87	87
U	65	65	65	65	65
V	47	47	47	47	47
W	84	84	84	84	84
X	214	214	214	214	214
Y	201	201	201	201	201
Z	109	109	109	109	109
∅	20	20	20	20	20
kg	9	11	14	16	19

(All dimensions in mm)

LASER & LOW BODY Fan Coil Units

Compatibility tables



**CSL00 (Built in)
CSR00 (Wall mounted)**
Fan speed selector



**CEL00 (Built in)
CER00 (Wall mounted)**
Thermostat with manual fan speed and automatic change over



**CML00 (Built in)
CMR00 (Wall mounted)**
Thermostat with manual fan speed and S/W change over

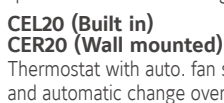

**CEL20 (Built in)
CER20 (Wall mounted)**
Thermostat with auto. fan speed and automatic change over

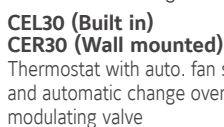

**CEL30 (Built in)
CER30 (Wall mounted)**
Thermostat with auto. fan speed and automatic change over for modulating valve

Features CEL/CER

- Dead band for change over 5°C or 2°C (factory set 2°C)
- Manual fan speeds or automatic (models 20 and 30)
- Thermostated fan control or continuous fan running
- Option water sensor WS for change over on coil (for 2 pipes)
- Led indicated status summer, winter or dead band
- Temperature setting for 7 to 30°C (comfort 20–25°C)
- Plastic pins for limiting temperature range
- Input for window contact
- Input for Economy/ occupancy mode
- Output for remote alarm
- Filter alarm 600 or 1200 running hours (factory set 1200 hours)
- With electrical heater post ventilation
- With Air sensor in the air intake destratification function (CEL only)

Compatibility table Thermostats / Valves / Heaters / Parallel connection / Water sensor / Minimum temperature thermostat

Factory fitted thermostat (built in)	Valves for 2 pipes		Valves for 4 pipes		Heaters KREL	Parallel connection		Water sensor WS	Min. Temp. Thermostat TM
	J3A2 (2p)	J3AM (2p)	J3A2 (4p)	J3AM (4p)		ON/OFF CBL20	Modulating CBL30		
CSL00 Fan speed selector						•			•
CML00 Thermostat with manual fan speed and S/W change over	•		•			•			•
CEL00 Thermostat with manual fan speed, dead band, automatic change over	•		•		•	•		•	•
CEL20 Thermostat with automatic fan speed, dead band, automatic change over	•		•		•	•		•	•
CEL30 Thermostat with automatic fan speed, dead band, automatic change over for modulating valve		•		•			•	•	•
Remote controllers and thermostats (wall mounted)									
CSR00 Fan speed selector						•			•
CMR00 Thermostat with manual fan speed and S/W change over	•		•			•			•
CER00 Thermostat with manual fan speed, dead band, automatic change over	•		•		•	•		•	•
CER20 Thermostat with automatic fan speed, dead band, automatic change over	•		•		•	•		•	•
CER30 Thermostat with automatic fan speed, dead band, automatic change over for modulating valve		•		•			•	•	•

• Compatible Not compatible

LASER & LOW BODY Fan Coil Units

Compatibility tables



Compatibility Options / Accessories / Models

		STANDARD								LOW BODY	
		LASER				CONCEALED				YLVR	YLIVR
Code	Designation	YLV	YLH	YLV-AF	YLH-AF	YLIV	YLIH	YLIV-AF	YLIH-AF	YLVR	YLIVR
Coils and heaters**											
BA1**	Additional 1 row heating	•	•	•	•	•	•	•	•	•	•
KREL**	Kit electrical heater with safety thermostat and relay	•	•	•	•	•	•	•	•		
Factory fitted thermostat (built in)											
CSL00	Fan speed selector (built in)	•		•		•		•		•	•
CML00	Thermostat with manual fan speed and S/W change over	•		•		•		•		•	•
CEL00	Thermostat with manual fan speed, dead band, automatic change over	Compatible with electrical heaters								•	•
CEL20	Thermostat with automatic fan speed, dead band, automatic change over	Compatible with electrical heaters								•	•
CEL30	Thermostat with automatic fan speed, dead band, automatic change over for modulating valves	•		•		•		•		•	•
CBL20	Parallel connection for ON/OFF valve	•	•	•	•	•	•	•	•	•	•
CBL30	Parallel connection for modulating valve	•	•	•	•	•	•	•	•	•	•
Remote controllers and thermostats (wall mounted)											
CSR00	Fan speed selector (wall mounted)	•	•	•	•	•	•	•	•	•	•
CMR00	Thermostat with manual fan speed and S/W change over	•	•	•	•	•	•	•	•	•	•
CER00	Thermostat with manual fan speed, dead band, automatic change over	Compatible with electrical heaters								•	•
CER20	Thermostat with automatic fan speed, dead band, automatic change over	Compatible with electrical heaters								•	•
CER30	Thermostat with automatic fan speed, dead band, automatic change over for modulating valves	•	•	•	•	•	•	•	•	•	•
Valves / Condensate pump / Water sensor / Minimum temperature thermostat (Factory fitted)											
J3A2 (2p)	3-way 4-ports on/off valves for 2-pipe systems	•	•	•	•	•	•	•	•	•	•
J3A2 (4p)	3-way 4-ports on/off valves for 4-pipe systems	•	•	•	•	•	•	•	•	•	•
J3AM (2p)	3-way 4-ports modulating valves for 2-pipe systems	•	•	•	•	•	•	•	•	•	•
J3AM (4p)	3-way 4-ports modulating valves for 4-pipe systems	•	•	•	•	•	•	•	•	•	•
DT (2p)	Shut-off valves for 2-pipe systems (in addition to J3A2/J3AM valves)	•	•	•	•	•	•	•	•	•	•
DT (4p)	Shut-off valves for 4-pipe systems (in addition to J3A2/J3AM valves)	•	•	•	•	•	•	•	•	•	•
PC	Condensate pump	•	•	•	•	•	•	•	•	•	•
WS	Water sensor	Compatible with CEL/CER									
TM	Minimum temperature thermostat	•	•	•	•	•	•	•	•	•	•
Feet and panels											
CP1	Set of painted feet	•				•					
ZL1	Set of feet + frontal socle	•									
PPV1	Vertical painted back panel	•		•						•	
PPH1	Horizontal painted back panel		•		•						
External air intake											
PA	Air intake plenum						•				
PAS	Air intake plenum collars						•				
PA90	90° air intake plenum						•				
RCA	Air intake duct fitting						•				
PM	Air delivery plenum with collars					•	•	•	•		•
PM90	90° air delivery plenum					•	•	•	•		•

- Compatible
- ◻ Compatible with conditions
- ◻ Not compatible

** Maximum of rows is indicated in the documentation, the maximum number of rows includes the heating row or electrical heater.

LASER ECM and LOW BODY ECM

0.6 to 9.35 kW



Technical features

Model		LASER ECM							LOW BODY ECM			
Sizes	(*)	512	514	516	520	522	524	528	112	114	216	
Total cooling capacity [kW]	(1)	max ...v	2.01	2.61	3.85	5.10	5.89	7.56	9.35	1.72	2.41	2.98
		med ...v	1.44	1.83	2.54	3.90	4.45	5.68	6.99	1.30	1.89	2.25
		min ...v	0.74	0.94	1.51	2.73	3.06	4.09	4.91	0.62	0.93	1.17
Sensible cooling capacity [kW]	(1)	max	1.68	2.17	3.18	4.17	4.88	6.18	7.68	1.17	1.96	2.44
		med	1.17	1.50	2.02	3.05	3.53	4.45	5.55	1.11	1.54	1.87
		min	0.55	0.78	1.21	2.10	2.35	3.14	3.76	0.47	0.74	0.96
Water flow in cooling [l/h]	(1)	max	334	434	665	847	982	1258	1558	295	396	504
		med	241	306	423	650	743	946	1164	224	324	387
		min	123	156	252	455	509	680	819	106	160	195
Pressure drop in cooling [kPa]	(1)	max	9.5	6.5	14.6	16.9	22.2	16.8	31.3	5.6	14.7	7.8
		med	5.4	3.4	8.5	10.6	13.5	10.0	18.5	3.2	10.2	4.8
		min	1.7	1.1	3.9	5.6	6.8	5.5	9.7	0.9	2.9	1.4
Heating capacity 2 pipes [kW]	(2)	max	2.79	3.69	4.13	6.86	7.97	10.03	12.35	2.06	3.22	3.98
		med	2.02	2.65	4.13	5.24	5.93	7.43	9.13	1.81	2.55	3.08
		min	1.06	1.38	2.22	3.71	4.15	5.39	6.43	0.80	1.20	1.67
Water flow in heating 2 pipes [l/h]	(2)	max	Water flow values as Cooling, accordingly to the EUROVENT standards and UNI ENV 1397									
		med										
		min										
Pressure drop in heating 2 pipes [kPa]	(2)	max	8.0	5.4	12.7	14.6	19.1	14.9	26.9	4.5	12.0	6.4
		med	5.3	3.5	8.7	17.6	18.2	10.7	23.0	2.6	8.3	2.9
		min	1.3	0.9	3.4	4.7	5.7	4.9	8.0	0.7	2.3	1.1
Heating capacity 4 pipes [kW]	(3)	max	2.03	2.73	3.63	5.52	6.17	8.12	8.89	1.81	2.66	3.74
		med	1.59	2.10	2.87	4.52	4.96	6.51	7.14	1.65	2.24	3.00
		min	0.97	1.29	2.21	3.49	3.79	5.11	5.59	0.84	1.20	1.90
Water flow in heating 4 pipes [l/h]	(3)	max	171	228	352	466	518	683	742	159	230	330
		med	134	177	267	383	420	552	603	145	195	253
		min	82	109	189	297	322	434	475	74	105	167
Pressure drop in heating 4 pipes [kPa]	(3)	max	5.6	10.0	20.5	21.1	25.9	45.4	56.9	4.7	11.5	23.0
		med	3.9	6.4	13.6	14.3	17.2	30.3	38.4	3.7	8.8	15.8
		min	1.4	2.6	8.4	8.7	10.2	19.2	24.2	1.1	2.9	6.7
Air flow [m3/h]		max	456	570	792	1082	1197	1567	2034	432	583	710
		med	298	376	487	757	819	1080	1353	286	379	475
		min	138	173	287	504	514	715	875	128	172	223
Sound power level [dB(A)]		max	55	59	57	57	62	63	69	55	57	53
		med	44	48	47	46	51	53	59	45	46	45
		min	25	29	37	35	39	43	48	31	34	33
Sound pressure level [dB(A)]	(4)	max	47	52	51	50	56	56	63	47	50	47
		med	37	42	41	40	45	47	53	38	40	39
		min	22	23	31	28	33	37	42	28	28	27
Power supply [V-ph-Hz]		230 / 1 / 50 + E										
Power input [W]		max	31	47	42	46	76	89	168	32	46	40
	Height	mm	623	623	623	699	699	699	699	395	395	395
	Width	mm	773	898	1023	1273	1273	1523	1773	680	805	930
Dimensions	Depth	mm	224	224	224	254	254	254	254	230	230	230

(1) Room temperature 27°C d.b., 19°C w.b. - Water temperature 7/12 °C

(2) Room temperature 20°C - Water inlet temperature: 50°C

(3) Room temperature 20°C - Water inlet temperature: 70/60°C.

(4) Sound pressure level in a 100 m³ room, at 1.5 m distance and reverberating time of 0.3 s.

(*) 512 - 514 (3v-6v-9v)

(*) 516 (2v-5v-10v)

(*) 520 - 522 - 524 - 528 (3v-6v-10v)



Manufacturer reserves the rights to change specifications without prior notice.



LASER ECM and LOW BODY ECM

Compatibility tables

Compatibility Options / Accessories / Models

		STANDARD								LOW BODY-ECM	
		LASER-ECM				CONCEALED-ECM				YLVLR	YLIVR
Code	Designation	YLV	YLH	YLV-AF	YLH-AF	YLIV	YLIH	YLIV-AF	YLIH-AF		
Coils and heaters**											
BA1**	Additional 1 row heating	•	•	•	•	•	•	•	•	•	•
KREL**	Kit electrical heater with safety thermostat and relay	•	•	•	•	•	•	•	•		
Factory fitted thermostat (built in)											
EDCL	Microprocessor control for ECM units	•		•		•		•		•	•
OBV11-ODC711	Omnibus control for ECM units + Analogue Plus console	•		•		•		•		•	•
OBV11-ODC211	Omnibus control for ECM units + Display console	•		•		•		•		•	•
Remote controllers and thermostats (wall mounted)											
EDCR	Microprocessor control for ECM units, for wall installation	•	•	•	•	•	•	•	•	•	•
OBV10+ODC716	Omnibus control for ECM units + Remote Analogue Plus console	•	•	•	•	•	•	•	•	•	•
OBV10+ODC216	Omnibus control for ECM units + Remote Display console	•	•	•	•	•	•	•	•	•	•
Valves / Condensate pump / Water sensor / Minimum temperature thermostat (Factory fitted)											
J3A2 (2p)	3-way 4-ports on/off valves for 2-pipe systems	•	•	•	•	•	•	•	•	•	•
J3A2 (4p)	3-way 4-ports on/off valves for 4-pipe systems	•	•	•	•	•	•	•	•	•	•
J3AM (2p)	3-way 4-ports modulating valves for 2-pipe systems	•	•	•	•	•	•	•	•	•	•
J3AM (4p)	3-way 4-ports modulating valves for 4-pipe systems	•	•	•	•	•	•	•	•	•	•
DT (2p)	Shut-off valves for 2-pipe systems (in addition to J3A2/J3AM valves)	•	•	•	•	•	•	•	•	•	•
DT (4p)	Shut-off valves for 4-pipe systems (in addition to J3A2/J3AM valves)	•	•	•	•	•	•	•	•	•	•
PC	Condensate pump	•	•	•	•	•	•	•	•	•	•
WS	Water sensor	Compatible with all the above listed controllers									
Feet and panels											
CP1	Set of painted feet	•				•					
ZL1	Set of feet + frontal socle	•									
PPV1	Vertical painted back panel	•		•						•	
PPH1	Horizontal painted back panel		•		•						
External air intake											
PA	Air intake plenum						•				
PAS	Air intake plenum collars						•				
PA90	90° air intake plenum						•				
RCA	Air intake duct fitting						•				
PM	Air delivery plenum with collars					•	•	•	•		•
PM90	90° air delivery plenum					•	•	•	•		•

- Compatible
- Compatible with conditions
- Not compatible

** Maximum of rows is indicated in the documentation, the maximum number of rows includes the heating row or electrical heater.

YEFB Hydro Blower

2 & 4 pipe system

A complete range from 2.8 kW up to 31.5 kW



CSR00 (Wall mounted)
Fan speed selector



CMR00 (Wall mounted)
Thermostat with manual fan speed and S/W change over



CER00 (Wall mounted)
Thermostat with manual fan speed and automatic change over

CER20 (Wall mounted)
Thermostat with auto. fan speed and automatic change over

CER30 (Wall mounted)
Thermostat with auto. fan speed and automatic change over for modulating valve



TUC03 Terminal unit controller
BacNET and N2 Metasys network compatible

YEFB Blower units are available in 6 sizes for horizontal concealed installations: thanks to their high ESP fans that can handle up to 250Pa, they are the ideal solution for air conditioning large spaces.



Selection software

Features

- 6 unit sizes for horizontal mounting
- Handles high external static pressure up to 250Pa
- Choice of 2 or 4 pipe systems
- Twin centrifugal fans
- Horizontal air return
- Air distribution plenum
- Electric heater option
- Optional paint finish
- F5 grade filter option
- 5 Row cooling coil option on sizes 060, 070

YEFB Hydro Blower

2.8 to 31.5 kW



Unit performance at 50 Pa external static pressure, with 4 row cooling coil

Model YEFB		020-4	030-4	040-4	050-4	060-4	070-4		
Total cooling capacity [kW]	(1)	max	7.14	10.12	12.84	15.02	19.92	24.31	
		med	5.40	8.29	10.82	13.04	16.31	19.72	
		min	3.33	7.00	8.98	11.66	13.53	18.11	
Sensible cooling capacity [kW]	(1)	max	5.90	8.62	11.31	13.51	17.17	22.14	
		med	4.23	6.53	8.94	11.42	13.67	19.05	
		min	2.42	5.27	7.03	7.90	11.08	17.11	
Water flow in cooling [l/h]	(1)	max	1 225	1 736	2 204	2 577	3 418	4 171	
		med	927	1 422	1 856	2 238	2 799	3 384	
		min	571	1 201	1 541	2 000	2 321	3 107	
Pressure drop in cooling [kPa]	(1)	max	27.9	35.0	38.3	52.4	19.1	27.6	
		med	17.7	24.0	27.9	39.9	13.2	23.4	
		min	8.1	17.6	19.6	32.1	9.4	20.1	
Heating capacity 2 pipes [kW]	(2)	max	9.93	14.24	18.43	21.47	28.24	36.11	
		med	7.40	11.11	15.55	18.51	23.55	33.19	
		min	4.01	9.13	12.03	16.24	19.36	31.31	
Water flow in heating 2 pipes [l/h]	(2)	max	Water flow values as Cooling, accordingly to the EUROVENT standards and UNI ENV 1397						
		med							
		min							
Pressure drop in heating 2 pipes [kPa]	(2)	max	15.5	31.1	34.7	47.6	17.0	28.2	
		med	8.8	21.5	25.2	36.3	11.6	25.1	
		min	2.0	15.6	17.9	29.7	8.3	21.1	
Heating capacity 2 pipes [kW]	(3)	max	16.78	24.42	31.16	36.33	48.45	62.46	
		med	12.49	18.93	26.2	31.24	39.13	56.49	
		min	6.75	15.47	20.23	27.39	32.07	53.22	
Water flow in heating 2 pipes [l/h]	(3)	max	1 349	2 145	2 467	2 927	3 917	5 392	
		med	1 102	1 662	2 059	2 511	3 222	5 092	
		min	591	1 359	1 695	2 216	2 638	4 618	
Pressure drop in heating 2 pipes [kPa]	(3)	max	17.8	37.1	38.9	55	19.4	34.1	
		med	9.9	24.8	27.6	41	13.7	30.3	
		min	2.3	17.5	19.2	32.7	9.6	25.3	
Air flow [m ³ /h]		max	1 387	2 160	2 760	3 513	4 118	5 541	
		med	928	1 450	2 076	2 746	3 176	4 928	
		min	491	1 115	1 545	2 320	2 548	4 340	
Sound power level [dB(A)]		max	63.8	65.4	70.1	70.4	76.6	78.4	
		med	53.5	59.7	63.0	67.1	69.3	75.6	
		min	47.2	54.9	56.4	63.2	64.2	72.9	
Sound pressure level [dB(A)]	(4)	max	53.2	54.8	59.5	61.9	66.0	69.1	
		med	42.9	49.1	52.4	56.4	58.8	66.4	
		min	33.1	44.3	45.8	52.6	53.6	63.8	
Power supply [V-ph-Hz]		230 / 1 / 50							
Power input [W]	max	187	392	508	703	1 056	1 794		
Absorbed current [A]	max	0.82	1.90	2.24	3.08	4.85	8.05		
Dimensions	Height	mm	407.6	407.6	407.6	407.6	517.6	517.6	
	Width	mm	902	902	902	902	1 160	1 160	
	Depth	mm	989.6	989.6	1 239.6	1 239.6	1 634.6	1 634.6	

(1) Room temperature 27°C d.b., 19°C w.b. - Water temperature 7/12 °C

(2) Room temperature 20°C - Water inlet temperature: 50°C

(3) Room temperature 20°C - Water inlet temperature: 70/60°C

(4) Sound pressure level in a 100 m³ room, at 1 m distance and reverberating time of 0.3 s.

4 pipe system not available with 4R coil

4 pipe system not available with 4R heating coil



Manufacturer reserves the rights to change specifications without prior notice.

YGFC Fan Coil Unit

2 & 4 pipe system

A complete range from 1.4 kW to 14.1 kW



Commercial Fan Coil Unit range, the YGFC Series is designed specially to meet the varied requirements of zone cooling or heating using chilled water or hot water. However in order to meet the growing demand in city centres where loads are high and space at a premium, YGFC units have a coil option suitable for use in 'district cooling' systems, thus helping reduce pumping power while increasing the overall system efficiency.

Features

- 10 unit sizes, suitable for horizontal or vertical mounting
- Models with or without casing
- 3 speed 'whisper quiet' fans
- District cooling coil option allows reduction in pump power and increase in system efficiency
- Single coil 3, or 4 rows
- Double coil 3 or 4 rows (cooling) & 1 row (heating)
- Electric heating option
- Blue Hydrophilic coated coil protection for increased product life
- Units are suitable for external static pressures of up to 60 Pa



Selection software

YGFC Fan Coil Unit

1.4 to 14.1 kW



Technical features

Model for YGFC MOD B		02 ST CB	03 ST CB	04 ST CB	05 ST CB	06 ST CB	07 ST CB	08 ST CB	10 ST CB	12 T CB	14 ST CB	
Total cooling capacity [kW]	(1) (2)	max	2.39	3.47	3.88	4.86	6.3	6.66	8.32	9.11	11.69	14.16
		med	2.07	3.03	3.46	4.48	5.66	6.02	7.68	8.36	10.31	13.24
		min	1.42	2.14	2.64	3.48	4.18	4.61	5.88	6.64	7.9	10.23
Sensible cooling capacity [kW]	(1) (2)	max	1.61	2.35	2.64	3.34	4.39	4.64	5.8	6.43	8.13	9.82
		med	1.4	2.04	2.34	3.06	3.89	4.16	5.31	5.86	7.1	9.05
		min	0.91	1.41	1.76	2.37	2.89	3.16	4.06	4.55	5.36	6.88
Water flow in cooling [l/h] *	(1) (2)	max	410	598	666	839	1 084	1 148	1 433	1 570	2 012	2 441
		med	356	522	598	770	976	1 037	1 321	1 440	1 775	2 282
		min	270	382	461	598	720	792	1 012	1 141	1 361	1 760
Pressure drop in cooling [kPa]	(1) (2)	max	33	40.4	46.1	50.5	38.1	39.9	41.9	36.3	52.6	80.9
		med	25.8	32	37	46.5	31.2	34.1	37.2	30.5	44.3	75.1
		min	13.9	19.3	22.3	38.5	20.2	23.5	25.8	20.2	29.1	49.3
Air flow [m3/h]		max	323	458	535	708	959	995	1 244	1 436	1 798	2 162
		med	274	392	460	626	827	862	1 121	1 281	1 505	1 909
		min	178	278	347	489	579	646	848	954	1 102	1 398
Sound power level [dB(A)]		max	38.5	40.3	42	45.5	47	47	47.5	48.5	51	52.5
		med	37	38	41	44.5	45	45	46.5	47	48	50
		min	31.5	34.1	37.5	38.9	39.4	39.8	40.6	42.4	41.2	43.9
Power supply [V-ph-Hz]		220 V/1 Ph/50 Hz										
Power input [W]		max	41	53	57	78	112	104	151	158	217	277
		med	37	48	52	72	103	94	136	149	199	248
		min	30	41	45	80	87	93	123	143	174	207
Dimensions	Height	mm	630	780	880	930	1 030	1 200	1 400	1 450	1 700	1 950
	Width	mm	541	541	541	541	541	541	541	541	541	541
	Depth	mm	233	233	233	233	233	233	233	233	233	233

(1) Room temperature 27°C d.b., 19°C w.b. - Water temperature 7/12 °C

(2) The above data is based on 4 Rows with nylon filter

(3) ESP @ 30 pa

* Water flow values as Cooling, accordingly to the EUROVENT standards and UNI ENV 1397



Manufacturer reserves the rights to change specifications without prior notice.

YHK Hydro Cassette

2 & 4 pipe system

A complete range from 1.3 kW to 11.1 kW



Coloured versions available as an option

YHK Hydro Cassette units are simple and elegant, discreet in their design. High standards of quality and reliability, combined with a wide range of accessories ensure a total solution for all comfort cooling and heating requirements.



Selection software

Wired controls



JWC-3V
Remote three speeds controller

JWC-T
JWC-3V + Electronic thermostat and Summer/Winter switch

JWC-AU
Automatic JWC-T



JTM-B
Digital Automatic Remote controller

TMO 503 SV2
Digital Automatic Remote controller to be mounted in the standard light wall box

Infrared control



TUC03 Terminal unit controller
BacNET and N2 Metasys network compatible

Features

- Cooling duty from 1.3 to 11.1 kW
- 2 & 4 pipes systems in all range
- 2 sizes: 600 x 600 & 800 x 800
- Possible choice between 6 fan speeds
- Condensate pump integrated in all range
- 2/3 way valves fitted or supplied loose in all range
- Coloured versions, possible to change the colour of the grill and the frame
- Possible to select a complete range of controls
- Electric heater fitted as an option for all range (2 pipe only)
- All metal parts insulated to avoid condensations

YHK Hydro Cassette

1.3 to 11.1 kW



Technical features

Model -2 pipes		YHK 20-2	YHK 25-2	YHK 40-2	YHK 50-2	YHK 65-2	YHK 95-2	YHK 110-2
Total cooling capacity 2 Pipes [kW]	(1)	max 2.0	2.7	4.3	5.0	6.2	9.5	11.1
		med 1.6	2.3	3.3	3.9	4.9	6.8	8.5
		min 1.3	1.8	2.3	2.9	4.2	5.3	5.3
Sensible cooling capacity 2 Pipes [kW]	(1)	max 1.6	2.0	3.2	3.7	4.6	6.5	8.3
		med 1.3	1.8	2.4	2.8	3.6	4.5	6.1
		min 1.0	1.4	1.6	2.1	3.0	3.5	3.7
Water flow in cooling 2 Pipes [l/h]	(1)	max 340	461	745	863	1 060	1 636	1 909
		med 280	402	574	667	845	1 166	1 453
		min 219	316	387	506	724	913	913
Pressure drop in cooling 2 Pipes [kPa]	(1)	max 10	9.7	15.1	19.7	21.6	26.9	35.6
		med 7	7.6	9.4	12.4	14.3	14.7	21.8
		min 4.5	4.9	4.6	7.5	10.9	9.4	9.4
Heating capacity 2 pipes [kW]	(2)	max 2.6	3.4	5.2	6.2	7.8	10.71	14.0
		med 2.1	2.9	3.9	4.6	6.0	7.34	10.3
		min 1.6	2.2	2.6	3.4	5.1	5.61	6.1
Water flow in heating 2 pipes [l/h] *	(2)	max 340	461	745	863	1 060	1 636	1 909
		med 280	402	574	667	845	1 166	1 453
		min 219	316	387	506	724	913	913
Pressure drop in heating 2 pipes [kPa]	(2)	max 9	8.2	11.4	17.7	15.1	23	30.6
		med 6	6.3	7.3	11.2	9.9	12.4	18.6
		min 4	4.1	3.5	6.7	6.7	7.9	7.9
Heating capacity 2 pipes [kW]	(3)	max 4.6	5.7	9.3	10.6	13.1	19.8	23.7
		med 3.7	4.9	7	8.3	10.7	13.4	17.3
		min 2.8	4.2	4.9	6.1	8.6	10.3	10.3
Water flow in heating 2 pipes [l/h]	(3)	max 393	488	795	914	1 130	1 699	2 037
		med 315	422	598	709	874	1 155	1 484
		min 240	360	415	524	741	882	882
Pressure drop in heating 2 pipes [kPa]	(3)	max 9.9	8.4	12.5	16	17.5	20.9	28.9
		med 6.5	6.4	7.6	10	11.3	10.6	16
		min 4	4.8	4	5.9	8.4	6.7	6.7

Model -4 pipes		YHK 20-4	YHK 25-4	YHK 40-4	YHK 50-4	YHK 65-4	YHK 95-4	YHK 110-4
Total cooling capacity 4 Pipes [kW]	(1)	max 2.3	2.7	3.3	3.8	6.3	7.7	8.9
		med 2.0	2.4	2.7	3.0	5.0	5.7	6.9
		min 1.5	1.9	1.9	2.4	4.1	4.5	4.5
Sensible cooling capacity 4 Pipes [kW]	(1)	max 1.9	2.0	2.6	3.0	4.7	5.8	6.8
		med 1.6	1.7	2.0	2.3	3.7	4.2	5.2
		min 1.2	1.3	1.3	1.8	3.0	3.3	3.3
Water flow in cooling 4 pipes [l/h]	(1)	max 401	464	574	655	1 090	1 326	1 529
		med 337	406	456	519	865	974	1 192
		min 260	318	318	406	712	777	777
Pressure drop in cooling 4 pipes [kPa]	(1)	max 13.5	8.8	13.4	17	18.9	26.9	34.7
		med 10	6.9	8.8	11.2	12.5	15.4	22.1
		min 6	4.6	4.6	7.2	8.8	10.3	10.3
Heating capacity 4 pipes [kW]	(3)	max 3.0	3.5	4.4	5.0	9.1	11.0	12.7
		med 2.5	3.0	3.5	4.0	7.2	8.1	10.0
		min 2.0	2.4	2.4	3.1	5.9	6.5	6.5
Water flow in heating 4 pipes [l/h]	(3)	max 261	298	378	426	783	946	1 092
		med 219	260	298	341	618	697	858
		min 169	209	209	267	508	555	555
Pressure drop in heating 4 pipes [kPa]	(3)	max 14.5	10.8	16.6	20.5	21.4	29.9	38.8
		med 10.5	8.5	10.8	13.8	14	17.4	25.3
		min 6.5	5.7	5.7	8.8	9.8	11.5	11.5
Air flow [m3/h]		max 610	520	710	880	1140	1500	1 820
		med 420	420	500	610	820	970	1 280
		min 310	310	320	430	630	710	710
Sound power level [dB(A)]		max 49	45	53	59	48	53	58
		med 40	40	45	49	40	40	48
		min 33	33	33	41	33	34	34
Sound pressure level [dB(A)]	(4)	max 40	36	44	50	39	44	49
		med 31	31	36	40	31	31	39
		min 24	24	24	32	24	25	25
Power supply [V-ph-Hz]		230V/1ph/50Hz						
Power input [W]	max	57	44	68	90	77	120	170
Absorbed current [A]	max	0.27	0.20	0.32	0.45	0.36	0.53	0.74
Water content (2 pipes) [l]		8.0	1.4	2.1	2.1	3.0	4.0	4.0
Dimensions	Height	mm	275	275	275	275	303	303
	Width	mm	575	575	575	575	820	820
	Depth	mm	575	575	575	575	820	820

(1) Room temperature 27°C d.b., 19°C w.b. - Water temperature 7/12 °C

(2) Room temperature 20°C - Water inlet temperature: 50°C - Water flow rate as for the cooling conditions.

(3) Room temperature 20°C - Water inlet temperature: 70/60°C

(4) Sound pressure level in a 100 m² room, at 1,5 m distance and reverberating time of 0,3 s.

* Water flow values as Cooling, accordingly to the EUROVENT standards and UNI ENV 1397



Manufacturer reserves the rights to change specifications without prior notice.

YHK-ECM Inverter Hydro Cassette

2 & 4 pipe system

A complete range from 1.8 kW to 10.8 kW



Wired control

JTM-B

Wall control with display that allows controlling one or more units in Master/Slave mode. The control is equipped with internal sensor to detect the room temperature, which can be defined as a priority compared to the return air sensor on the fan coil.



Infrared control



TUC03 Terminal unit controller

BacNET and N2 Metasys network compatible



Coloured versions available as an option

YHK ECM water cassette is the result of significant technical and design research focused on providing an avant-garde product in terms of performance, low noise and control flexibility. YHK ECM series uses an innovative brushless electric motor controlled by an inverter card that varies the air flow continuously by means of a 0-10 V signal. The extreme efficiency, also at a low speed, makes it possible to greatly reduce electrical consumption (more than 75% less in comparison to a traditional motor) with absorption values, under normal operating conditions, that are no greater than 10 Watt in the entire range.

Features

- Cooling duty from 1.8 to 10.8 kW
- YHK: models with infrared control (standard)
- YHK-MP: models with wired control (accessory)
- 2 (-2) & 4 (-4 or -6) pipes systems
- 2 sizes: 600 x 600 & 800 x 800
- Condensate pump integrated in all range
- 2/3 way valves fitted or supplied loose in all range
- Coloured versions, possible to change the colour of the grid and the frame
- All metal parts insulated to avoid condensations
- Inverter fan motor for a very quiet operation
- Electrical consumption reduced by up to 75%
- Specific range of controllers with master-slave function



Selection software

YHK-ECM Inverter Hydro Cassette

1.8 to 10.8 kW



Technical features

Model -2 pipes		YHK-ECM 25-2	YHK-ECM 40-2	YHK-ECM 50-2	YHK-ECM 65-2	YHK-ECM 95-2	
Total cooling capacity 2 Pipes [kW]	(1)	max 10v	2.8	4.3	5.0	6.3	10.8
		med 5v	2.2	3.1	3.9	5.2	7.7
		min 1v	1.8	2.2	2.6	4.2	5.3
Sensible cooling capacity 2 Pipes [kW]	(1)	max	2.1	3.2	3.7	4.7	7.9
		med	1.6	2.2	2.8	3.8	5.5
		min	1.4	1.6	1.8	3.0	3.7
Water flow in cooling 2 Pipes [l/h]	(1)	max	473	744	864	1 089	1 848
		med	373	524	666	885	1 328
		min	317	385	441	723	909
Pressure drop in cooling 2 Pipes [kPa]	(1)	max	10.1	15.1	19.7	22.7	33.6
		med	6.6	9.4	12.4	15.6	18.5
		min	4.9	4.6	5.9	10.9	9.4
Heating capacity 2 pipes [kW]	(2)	max	3.4	5.2	6.2	8.0	12.7
		med	2.7	3.6	4.6	6.4	8.8
		min	2.2	2.6	3.0	5.1	5.9
Pressure drop in heating 2 pipes [kPa]	(2)	max	8.7	13.1	17.7	19.5	28.8
		med	5.5	6.6	10.5	12.8	14.9
		min	4.0	3.6	4.7	8.7	7.2

Model -4 pipes		YHK-ECM 25-4	YHK-ECM 40-6	YHK-ECM 50-6	YHK-ECM 65-4	YHK-ECM 95-6	
Total cooling capacity 4 Pipes [kW]	(1)	max	2.8	3.9	4.5	6.5	9.9
		med	2.2	2.8	3.5	5.3	7.2
		min	1.9	2.1	2.4	4.3	5.0
Sensible cooling capacity 4 Pipes [kW]	(1)	max	2.1	3.0	3.5	4.8	7.4
		med	1.6	2.0	2.6	3.8	5.2
		min	1.3	1.5	1.7	3.1	3.5
Water flow in cooling 4 pipes [l/h]	(1)	max	476	676	779	1 120	1 697
		med	375	483	608	908	1 233
		min	318	359	409	740	856
Pressure drop in cooling 4 pipes [kPa]	(1)	max	9.5	10.5	13.1	19.8	30.1
		med	6.2	5.7	8.4	13.6	17.0
		min	4.6	3.5	4.1	9.4	8.8
Heating capacity 4 pipes [kW]	(3)	max	3.6	3.4	3.8	9.4	9.5
		med	2.9	2.5	3.1	7.5	7.2
		min	2.4	2.0	2.2	6.1	5.2
Water flow in heating 4 pipes [l/h]	(3)	max	311	288	326	805	818
		med	245	217	263	649	616
		min	209	170	189	528	449
Pressure drop in heating 4 pipes [kPa]	(3)	max	11.7	9.0	11.0	22.5	18.0
		med	7.6	5.5	7.5	15.5	11.0
		min	5.7	3.5	4.5	10.5	6.5
Air flow [m3/h]		max	535	710	880	1 165	1 770
		med	380	445	610	870	1 130
		min	310	310	360	630	710
Sound power level [dB(A)]		max	47	54	60	48	57
		med	39	43	50	39	47
		min	33	33	37	33	34
Sound pressure level [dB(A)]	(4)	max	38	45	51	39	48
		med	30	34	41	30	38
		min	24	24	28	24	25
Power supply [V-ph-Hz]		230V/1ph/50hZ					
Power input [W]	max	16	31	62	33	108	
Water content (2 pipes) [l]		1.4	2.1	2.1	3.0	4.0	
Absorbed current [A]	max	0.15	0.27	0.52	0.28	0.92	
Dimensions	Height	mm	275	275	275	303	303
	Width	mm	575	575	575	820	820
	Depth	mm	575	575	575	820	820

- (1) Room temperature 27°C d.b., 19°C w.b. - Water temperature 7/12 °C
- (2) Room temperature 20°C - Water inlet temperature: 50°C - Water flow rate as for the cooling conditions.
- (3) Room temperature 20°C - Water inlet temperature: 70/60°C
- (4) Sound pressure level in a 100 m² room, at 1,5 m distance and riverberating time of 0,3 s.
- * Water flow values as Cooling, accordingly to the EUROVENT standards and UNI ENV 1397



Condensate pump integrated in all sizes



Metal parts insulated to avoid condensation



2 or 3 way valves fitted or supplied loose in all sizes



Outer casing as an option to integrate the water cassette into any environment



Manufacturer reserves the rights to change specifications without prior notice.

Compatibility table / Codes

Model with AC motor (without air diffuser)		YHKY 20	YHKY 25	YHKY 40	YHKY 50	YHKY 65	YHKY 95	YHKY 110
Cassette YHKY	2 pipe system	0079100K	0079000K	0079001K	0079002K	0079003K	0079004K	0079005K
	4 pipe system	0079110K	0079010K	0079011K	0079012K	0079013K	0079014K	0079015K
Cassette YHKY-MP (IR remote control and sensor NOT included)	2 pipe system	0079170K	0079171K	0079172K	0079173K	0079174K	0079175K	0079176K
	4 pipe system	0079180K	0079181K	0079182K	0079183K	0079184K	0079185K	0079186K
Cassette YHKY-E - with electric resistance	2 pipe system	-	0079060K	0079061K	0079062K	0079063K	0079064K	0079065K
Cassette YHKY-MP-E - with electric resistance	2 pipe system	-	0079191K	0079192K	0079193K	0079194K	0079195K	0079196K
Cassette YHKY-REB with remote electric board	2 pipe system	0079120K	0079020K	0079021K	0079022K	0079023K	0079024K	0079025K
	4 pipe system	0079130K	0079030K	0079031K	0079032K	0079033K	0079034K	0079035K
Model with ECM motor (without air diffuser)		-	YHKY 25	YHKY 40	YHKY 50	YHKY 65	YHKY 95	-
Cassette YHKY-ECM - basic model	2 pipe system	-	0079801K	0079802K	0079803K	0079804K	0079805K	-
	4 pipe system	-	0079811K	0079812K	0079813K	0079814K	0079815K	-
Cassette YHKY-MP- ECM (IR remote control and sensor NOT included)	2 pipe system	-	0079911K	0079912K	0079913K	0079914K	0079915K	-
	4 pipe system	-	0079921K	0079922K	0079923K	0079924K	0079925K	-
Cassette YHKY-ECM-E - with electric resistance	2 pipe system	-	0079841K	0079842K	0079843K	0079844K	0079845K	-
Cassette YHKY-ECM-MP-E - with electric resistance	2 pipe system	-	0079901K	0079902K	0079903K	0079904K	0079905K	-
Mandatory accessories (units cannot work without them)								
Air diffuser - intake grid, frame and louvres in RAL 9003 white colour			AKPA 600			AKPA 800		
Accessories (factory fitted)								
Valves (220V On/Off)								
3 way valve + mounting kit for 2 pipe models (factory fitted)			9079510			9079511		
3 way valve + mounting kit for 4 pipe models (factory fitted)			9079512			9079513		
2 way valve + mounting kit for 2 pipe models (factory fitted)			9079515			9079516		
2 way valve + mounting kit for 4 pipe models (factory fitted)			9079517			9079518		
2 way DN 15 balance valve for main coil + connection kit (fact. fitted) *			9079771			9079791	-	
2 way DN 20 balance valve for main coil + connection kit (fact. fitted) *			-			9079792		
2 way DN 15 balance valve for additional coil + connection kit (fact. fitted) *			9079773			9079793		
Accessories (supplied loose)								
Air diffusers / Panels								
Air diffuser - other colours (*)			Contact Johnson Controls					
Valves (220V On/Off)								
3 way valve + mounting kit for 2 pipe models (not fitted)			9079500			9079501		
3 way valve + mounting kit for 4 pipe models (not fitted)			9079502			9079503		
2 way valve + mounting kit for 2 pipe models (not fitted)			9079505			9079506		
2 way valve + mounting kit for 4 pipe models (not fitted)			9079507			9079508		
2 way DN 15 balance valve for main coil + connection kit (not fitted) *			9079761			9079781	-	
2 way DN 20 balance valve for main coil + connection kit (not fitted) *			-			9079782		
2 way DN 15 balance valve for additional coil + connection kit (not fitted) *			9079763			9079783		
Other type of valves			Contact Johnson Controls					
Other Accessories								
Outer casing OCA 600			9079240			-		
Outer casing OCA 800			-			9079250		
3 way valve + mounting kit for units with outer casing OCA (not fitted)			9079155			9079156		
Fresh air duct FAD			-			6078005		
Fresh air kit 1 way not suitable for units with outer casing OCA - FAK 600			9079230			-		
Fresh air kit 1 way not suitable for units with outer casing OCA - FAK 800			-			9079231		
FREE wireless control system for YHKY basic model								
Remote Control FREE-COM			-			9060572		
Power unit fitted FREE-USM			-			9079107		
Not Mounted Electronic Board FREE-UPS			-			9060570		
Temperature sensor FREE-SEN			-			9060573		
Low temperature cut out FREE-NTC			-			3021090		
CONTROLS for YHKY (AC versions)								
Remote three speed control JWC-3V (1) (5)			9066642			9066642		
Remote three speed control + electronic thermostat and manual S/W switch JWC-T (2)			9066630K			9066630K		
Remote three speed control + electronic thermostat and centralized/ manual S/W switch JWC-TQR (2) (4)			9066632K			9066632K		
Automatic speed control with electronic thermostat and S/W switch - JWC-AU (to be used with JPF-AU and JP-AU only) (2) (4)			9066331E			9066331E		
Automatic speed control with electronic thermostat to be mounted in the light wall box TMO-503-SV2 (3) (5)			9060172			9060172		
Electromechanical thermostat T2T (5) (6)			9060174			9060174		
Power unit JPF-AU for JWC-AU and JTM-B remote controls, fitted on the unit			-			9066641		
Power unit JP-AU for JWC-AU and JTM-B remote controls, not fitted on the unit			-			9066640		
Control accessories for all versions (supplied with separate packaging)								
Low temperature cut-out for controls JWC-T			-			9053048		
Low temperature cut-out for controls JWC-TQR, JWC-AU and JTM-B			-			3021090		
T2 sensor to be used as Change-over for controls JWC-AU and JTM-B			-			9025310		
Change-over 15-25 for control JWC-TQR			-			9053049		
Receiver SEL2M			-			9079109		

* For 4 pipes unit must consider both the valve for main coil than the valve for additional coil.

(1) Not to be used with valves and/or low temperature cut-out. (2) It can be used with valves and/or low temperature cut-out. (3) Low temperature cut-out included.

(4) It can be used with Change Over. (5) Not suitable with -E electric heater. (6) Not to be used with low temperature cut-out.

Compatibility table / Codes

CONTROLS for YHKY-MP (AC versions)	YHKY 20	YHKY 25	YHKY 40	YHKY 50	YHKY 65	YHKY 95	YHKY 110
Wall control JTM-B				9066331E			
Wire, receiver and IR remote control kit RCS-RT03				9079117			
Infra red remote control RT-03				3021203			
Wire and receiver kit RCS				9079116			
Receiver for IR remote control for metal grid MD600 RS		9066338				9066338	
Multifunction control PSM-DI				3021293			
T2 sensor (to be used as change over or min.temp. sensor) T2				9025310			
CONTROLS for YHKY-ECM (ECM motor)							
Automatic speed control with electronic thermostat and S/W switch - JWC-AU (to be used with JPF-AU and JP-AU only) (2) (4)		9066632K				9066632K	
Automatic remote control with electronic thermostat, S/W switch and liquid crystall display JTM-B (to be used with JPF-AU and JP-AU only) (2) (4)		9066331E				9066331E	
WM-S-ECM Continuous fan speed control with electronic thermostat, summer/winter switch and LCD display				9066644			
Power unit JPF-AU for JWC-AU and JTM-B remote controls, fitted on the unit				9066641			
Power unit JP-AU for JWC-AU and JTM-B remote controls, not fitted on the unit				9066640			
Control accessories for all versions (supplied with separate packaging)							
Low temperature cut-out for controls JWC-AU and JTM-B				3021090			
T2 sensor to be used as Change-over for controls JWC-AU and JTM-B				9025310			
Change-over 15-25 for control JWC-TQR				9053049			
CONTROLS for YHKY-MP-ECM (ECM motor)							
Wall control JTM-B				9066331E			
Wire, receiver and IR remote control kit RCS-RT03				9079117			
Infra red remote control RT-03				3021203			
Wire and receiver kit RCS				9079116			
Receiver for IR remote control for metal grid MD600 RS				9066338			
Multifunction control PSM-DI				3021293			
T2 sensor (to be used as change over or min.temp. sensor) T2				9025310			
Management system for a network of fan coils with MB electronic board							
Hardware / software supervisory system Net				9079118			
Router S				3021290			
Relay output board SIOS				3021292			

Dimensions

Sizes 20 to 50 (Version 600x600)

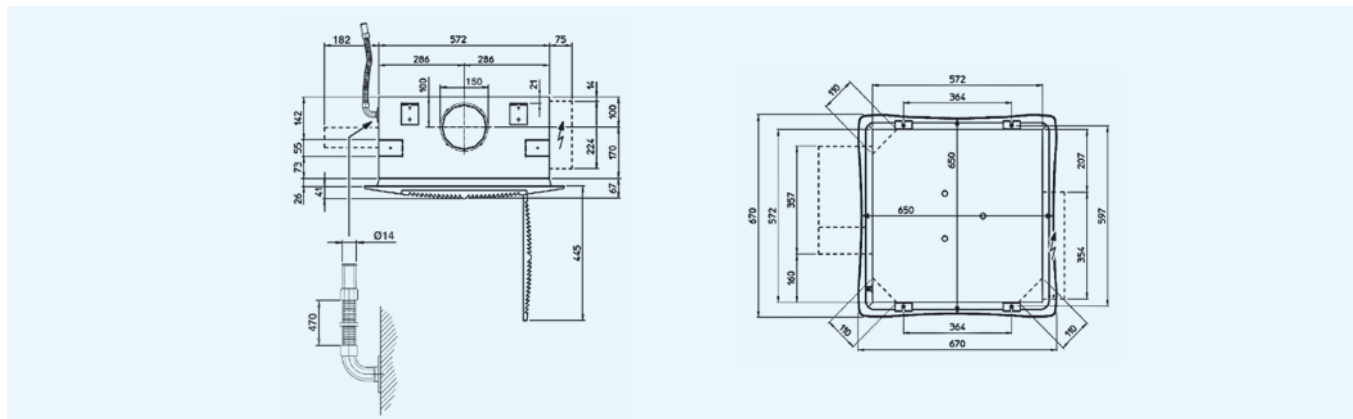

All dimensions in mm. Drawings not a scale.

Sizes 65 to 110 (Version 800x800)

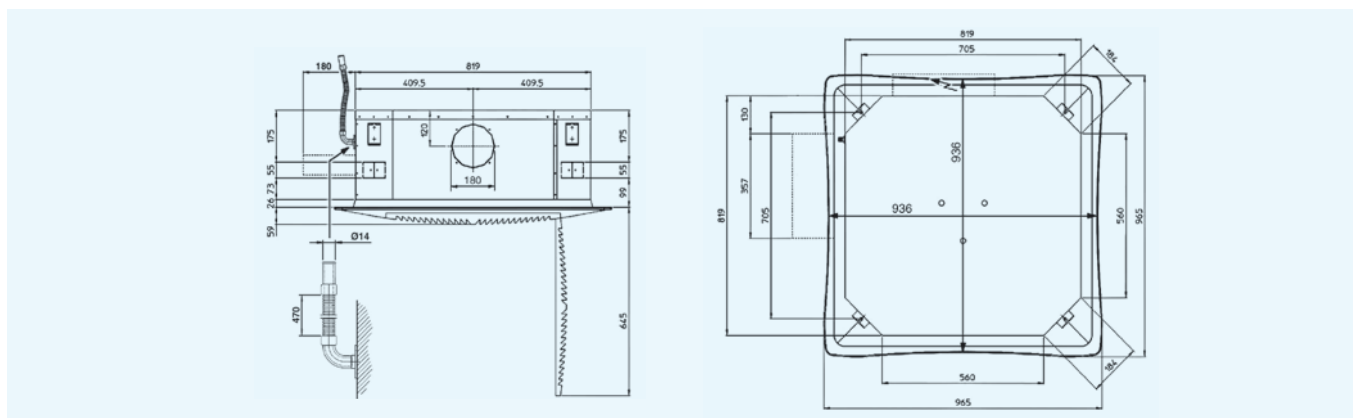

All dimensions in mm. Drawings not a scale.

YFCC Coanda Hydro Cassette

2 & 4 pipe system

A complete range from 0.9 kW to 4.0 kW



Thanks to its unique diffuser, YFCC cassette units generate an airflow with a "coanda" effect. The unit is suitable for installation in a suspended ceiling. Air intake is from the bottom while the air is supplied parallel to the ceiling.

The resulting "coanda" effect creates excellent draft free distribution of the air inside the room. Units can be supplied with 1 coil (2 pipe system) with optional electric heating element, or with 2 coils (4 pipe system) with one or two rows.



Coanda effect



Wired controls

JWC-3V

Remote three speeds controller

JWC-T

JWC-3V + Electronic thermostat and Summer/Winter switch

JWC-AU

Automatic JWC-T



JTM-B

Digital Automatic Remote controller

TMO 503 SV2

Digital Automatic Remote controller to be mounted in the standard light wall box



Infrared control

Features

- Coanda effect units, allowing easier and cheaper installation
- Cooling duty from 0.9 to 4.0 kW
- 2 & 4 pipes systems in all range
- 3 sizes: 600 x 600, 600 x 1000 & 600 x 1200
- 2/3 way valves fitted or supplied loose in all range
- Left and right hand (optional) water connections
- 6 fan speeds (3 pre-wired)
- Air throw till 7.6m (cooling) and 9.5m (heating)



Selection software



YFCC Coanda Hydro Cassette

0.9 to 4.0 kW



Technical features

Model -2 pipes		YFCC 130	YFCC 140	YFCC 230	YFCC 240	YFCC 330	YFCC 340	
Total cooling capacity 2 Pipes [kW]	(1)	max	1.5	1.74	2.37	2.57	3.34	4.02
		med	1.06	1.19	1.62	1.72	2.84	3.56
		min	0.88	0.97	1.37	1.44	1.97	2.49
Sensible cooling capacity 2 Pipes [kW]	(1)	max	1.18	1.31	1.77	1.88	2.51	2.98
		med	0.81	0.88	1.19	1.24	2.11	2.63
		min	0.66	0.71	1.0	1.04	1.44	1.81
Pressure drop in cooling 2 Pipes [kPa]	(1)	max	6.1	12.9	7.6	12.1	16.2	15.5
		med	3.3	6.7	3.9	6.0	12.1	12.6
		min	2.4	4.7	2.9	4.4	6.4	6.7
Heating capacity 2 pipes [kW]	(2)	max	1.93	2.1	2.86	3.12	4.02	4.77
		med	1.33	1.42	1.91	2.03	3.37	4.2
		min	1.08	1.1	1.6	1.69	2.3	2.9
Pressure drop in heating 2 pipes [kPa]	(2)	max	4.9	10.7	6.3	10.2	13.4	12.6
		med	2.6	5.4	3.1	4.8	9.8	10.0
		min	1.8	3.7	2.3	3.5	5.2	5.5
Air flow [m3/h]		max	280	280	380	380	540	620
		med	180	180	240	240	440	540
		min	140	140	200	200	290	360
Sound power level [dB(A)]		max	52	52	48	48	52	55
		med	41	41	36	36	46	52
		min	35	35	33	33	35	41
Sound pressure level [dB(A)]	(4)	max	43	43	39	39	43	46
		med	32	32	27	27	37	43
		min	26	26	24	24	26	32
Power supply [V-ph-Hz]		230V/1ph/50Hz						
Power input [W]	max	66	66	71	71	84	84	
Absorbed current [A]	max	0.30	0.30	0.32	0.32	0.38	0.38	
Dimensions	Height	mm	309	309	309	309	309	
	Width	mm	592	592	592	592	592	
	Depth	mm	592	592	970	970	1 192	

Model -4 pipes		YFCC 130+1	YFCC 230+1	YFCC 330+1	
Total cooling capacity 4 Pipes [kW]	(1)	max	1.5	2.37	3.34
		med	1.06	1.62	2.84
		min	0.88	1.37	1.97
Sensible cooling capacity 4 Pipes [kW]	(1)	max	1.18	1.77	2.51
		med	0.81	1.19	2.11
		min	0.66	1.0	1.44
Pressure drop in cooling 4 pipes [kPa]	(1)	max	6.1	7.6	16.2
		med	3.3	3.9	12.1
		min	2.4	2.9	6.4
Heating capacity 4 pipes [kW]	(3)	max	1.47	2.35	3.3
		med	1.08	1.71	2.87
		min	0.92	1.49	2.12
Pressure drop in heating 4 pipes [kPa]	(3)	max	3.6	2.0	4.3
		med	2.1	1.2	3.4
		min	1.6	0.9	2.0
Air flow [m3/h]		max	280	380	540
		med	180	240	440
		min	140	200	290
Sound power level [dB(A)]		max	52	48	52
		med	41	36	46
		min	35	33	35
Sound pressure level [dB(A)]	(4)	max	43	39	43
		med	32	27	37
		min	26	24	26
Power supply [V-ph-Hz]		230V/1ph/50Hz			
Power input [W]	max	66	71	84	
Absorbed current [A]	max	0.30	0.32	0.38	
Dimensions	Height	mm	309	309	
	Width	mm	592	592	
	Depth	mm	592	970	

(1) Room temperature 27°C d.b., 19°C w.b. - Water temperature 7/12 °C
 (2) Room temperature 20°C - Water inlet temperature: 50°C - Water flow rate as for the cooling conditions.
 (3) Room temperature 20°C - Water inlet temperature: 70/60°C
 (4) Sound pressure level in a 100 m² room, at 1,5 m distance and reverberating time of 0,3 s.
 * Water flow values as Cooling, accordingly to the EUROVENT standards and UNI ENV 1397



Manufacturer reserves the rights to change specifications without prior notice.

YFCC-ECM Coanda Hydro Cassette

2 & 4 pipe system

A complete range from 0.8 kW to 4.0 kW

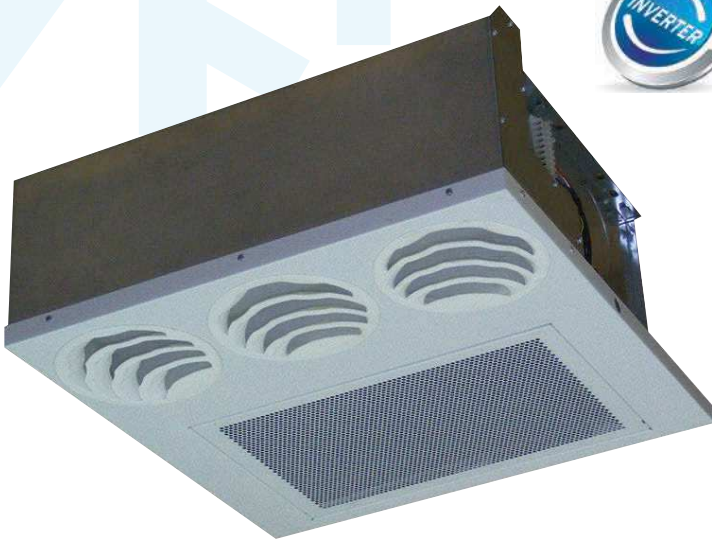

Wired controls

JWC-AU

Automatic remote controller



T-MB

Wall control with display that allows controlling one or more units in Master/Slave mode. The control is equipped with internal sensor to detect the room temperature, which can be defined as a priority compared to the return air sensor on the fan coil.



WM-S-ECM

Continuous fan speed control with electronic thermostat and s/w switch



Infrared control



Thanks to its unique diffuser, YFCC cassette units generate an airflow with a "coanda" effect. The unit is suitable for installation in a suspended ceiling. Air intake is from the bottom while the air is supplied parallel to the ceiling.

The resulting "coanda" effect creates excellent draft free distribution of the air inside the room. Units can be supplied with 1 coil (2 pipe system) with optional electric heating element, or with 2 coils (4 pipe system) with one or two rows.



Coanda effect

Features

- Coanda effect units, allowing easier and cheaper installation
- Cooling duty from 0.8 to 4.0 kW
- 2 & 4 pipes systems in all range
- 3 sizes: 600 x 600, 600 x 1000 & 600 x 1200
- 2/3 way valves fitted or supplied loose in all range
- Left and right hand (optional) water connections
- 6 fan speeds (3 pre-wired)
- Air throw till 7.6m (cooling) and 9.5m (heating)
- ECM variable speed motor



Selection software



YFCC-ECM Coanda Hydro Cassette

0.8 to 4.0 kW



Technical features

Model -2 pipes		YFCC-ECM 130	YFCC-ECM 140	YFCC-ECM 230	YFCC-ECM 240	YFCC-ECM 330	YFCC-ECM 340	
Total cooling capacity 2 Pipes [kW]	(1)	max 10v	1.56	1.81	3.16	3.5	3.75	4.02
		med 5v	1.18	1.34	2.31	2.51	2.78	2.94
		min 1v	0.82	0.91	1.46	1.55	1.87	1.95
Sensible cooling capacity 2 Pipes [kW]	(1)	max	1.24	1.38	2.41	2.6	2.83	2.98
		med	0.91	0.99	1.73	1.84	2.06	2.15
		min	0.62	0.66	1.07	1.11	1.37	1.41
Pressure drop in cooling 2 Pipes [kPa]	(1)	max	6.5	13.9	12.6	20.8	19.8	15.5
		med	4	8.1	7.3	11.6	11.7	8.9
		min	2.1	4.1	3.2	5	5.8	4.3
Heating capacity 2 pipes [kW]	(2)	max	2.02	2.2	3.85	4.32	4.54	4.78
		med	1.5	1.6	2.79	3.03	3.3	3.44
		min	1.02	1.07	1.72	1.82	2.19	2.25
Pressure drop in heating 2 pipes [kPa]	(2)	max	5.3	11.6	10.4	17.1	16.6	13
		med	3.3	6.6	6	9.4	9.4	7.4
		min	1.7	3.3	2.6	4.1	4.7	3.5
Air flow [m3/h]		max	295	295	540	540	620	620
		med	205	205	370	370	430	430
		min	130	130	215	215	275	275
Sound power level [dB(A)]		max	55	55	56	56	58	58
		med	46	46	46	46	48	48
		min	35	35	34	34	36	36
Sound pressure level [dB(A)]	(4)	max	46	46	47	47	49	49
		med	37	37	37	37	39	39
		min	26	26	25	25	27	27
Power supply [V-ph-Hz]		230V/1ph/50Hz						
Power input [W]	max	29	29	37	37	42	42	
Absorbed current [A]	max	0.24	0.24	0.29	0.29	0.35	0.35	
Dimensions	Height	mm	309	309	309	309	309	
	Width	mm	592	592	592	592	592	
	Depth	mm	592	592	970	970	1 192	

Model -4 pipes		YFCC-ECM 130+1	YFCC-ECM 230+1	YFCC-ECM 330+1	
Total cooling capacity 4 Pipes [kW]	(1)	max 10v	1.56	3.16	3.75
		med 5v	1.18	2.31	2.78
		min 1v	0.82	1.46	1.87
Sensible cooling capacity 4 Pipes [kW]	(1)	max	1.24	2.41	2.83
		med	0.91	1.73	2.06
		min	0.62	1.07	1.37
Pressure drop in cooling 4 pipes [kPa]	(1)	max	6.5	12.6	19.8
		med	4	7.3	11.7
		min	2.1	3.2	5.8
Heating capacity 4 pipes [kW]	(3)	max	1.52	3.01	3.64
		med	1.18	2.31	2.82
		min	0.87	1.58	2.04
Pressure drop in heating 4 pipes [kPa]	(3)	max	3.8	3.1	5.1
		med	2.5	2	3.3
		min	1.4	1	1.8
Air flow [m3/h]		max	295	540	620
		med	205	370	430
		min	130	215	275
Sound power level [dB(A)]		max	55	56	58
		med	46	46	48
		min	35	34	36
Sound pressure level [dB(A)]	(4)	max	46	47	49
		med	37	37	39
		min	26	25	27
Power supply [V-ph-Hz]		230V/1ph/50Hz			
Power input [W]	max	29	37	42	
Absorbed current [A]	max	0.24	0.29	0.35	
Dimensions	Height	mm	309	309	
	Width	mm	592	592	
	Depth	mm	592	970	

(1) Room temperature 27°C d.b., 19°C w.b. - Water temperature 7/12 °C
 (2) Room temperature 20°C - Water inlet temperature: 50°C - Water flow rate as for the cooling conditions.
 (3) Room temperature 20°C - Water inlet temperature: 70/60°C
 (4) Sound pressure level in a 100 m² room, at 1,5 m distance and reverberating time of 0,3 s.
 * Water flow values as Cooling, accordingly to the EUROVENT standards and UNI ENV 1397



Manufacturer reserves the rights to change specifications without prior notice.

Options & Accessories YFCC / YFCC-ECM

Compatibility table / Codes

Model with AC motor		YFCC 130	YFCC 140	YFCC 230	YFCC 240	YFCC 330	YFCC 340
Cassette YFCC	2 pipe system	0064001K	0064011K	0064002K	0064012K	0064003K	0064013K
	4 pipe system (+1)	0064021K	0064031K	0064022K	0064032K	0064023K	0064033K
	4 pipe system (+2)	0064041K	-	0064042K	-	0064043K	-
Model with ECM motor							
Cassette YFCC-ECM	2 pipe system	0064201K	0064211K	0064202K	0064212K	0064203K	0064213K
	4 pipe system (+1)	0064221K	0064231K	0064222K	0064232K	0064223K	0064233K
	4 pipe system (+2)	0064241K	-	0064242K	-	0064243K	-
Options (Factory fitted)							
Right hand connection		Contact Johnson Controls					
Valves (220V On/Off) (factory fitted)							
Kit 3 way valve size 1-5 mounted MBVM-JC 1-5 V.220 (YFCC size 1-2)		9066561			-		
Kit 3 way valve size 6-9 mounted MBVM-JC 6-9 V.220 (YFCC size 3)		-			9060471		
Kit 3 way valve additional battery size 1-9 mounted ABVM-JC 1-7 V.220 (YFCC 4 pipes all sizes)		9060472			-		
Kit 2 way valve size 1-5 and additional battery mounted V2M-JC 1-5 V.220 (YFCC size 1-2)		9060476			-		
Kit 2 way valve size 6-9 primary battery mounted V2M-JC 6-9 V.220 (YFCC size 3)		-			9060477		
Kit 2 way valve all sizes 4 pipes to be used for the additional battery not mounted V2L-JC 1-5 V.220		9060476			-		
Simplified kit for 3 way valve for CD version fitted (sizes 1-5) VS DM-JC G1-5 V.220 (YFCC size 1-2)		9066571			-		
Simplified kit for 3 way valve for CD version fitted (sizes 6-9) VS DM-JC G6-9 V.220 (YFCC size 3)		-			9060484		
Simplified kit for 3 way valve for CD version fitted - additional battery (all sizes) VS AM-JC G1-9 V.220 (YFCC all sizes)		9060483			-		
3 way double valve kit for 4 tube installation and single coil + kit fitted on the unit (YFCC all sizes)		9066572W			-		
2 way DN 10 balance for main coil + kit fitted on the unit (YFCC size 1)		9066660	-		-		
2 way DN 15 balance for main coil + kit fitted on the unit (YFCC sizes 2-3)		-	9066661		-		
2 way DN 10 balance for additional coil + kit fitted on the unit (all sizes)		9066663			-		
Accessories (supplied loose)							
Valves 220V On/Off (supplied loose)							
Kit 3 way valve size 1-5 not mounted MBVL-JC 1-5 V.220 (YFCC size 1-2)		9066560			-		
Kit 3 way valve size 6-9 not mounted MBVL-JC 6-9 V.220 (YFCC size 3)		-			9060474		
Kit 3 way valve additional battery size 1-9 not mounted ABVL-JC 1-7 V.220 (YFCC all sizes)		9060475			-		
Kit 2 way valve size 1-5 and additional battery not mounted V2L-JC 1-5 V.220 (YFCC size 1-2)		9060478			-		
Kit 2 way valve size 6-9 primary battery not mounted V2L-JC 4-7 V.220 (YFCC size 3)		-			9060479		
Kit 2 way valve size 1-5 and to be used for the additional battery not mounted V2L-JC 1-5 V.220		9060478			-		
Simplified kit for 3 way valve for CD version not fitted (sizes 1-5) VS DS-JC G1-5 V.220 (YFCC size 1-2)		9066570			-		
Simplified kit for 3 way valve for CD version not fitted (sizes 6-9) VS DS-JC G6-9 V.220 (YFCC size 3)		-			9060481		
Simplified kit for 3 way valve for CD version not fitted - additional battery (all sizes) VS AS-JC G1-9 V.220 (YFCC all sizes)		9060480			-		
3 way double valve kit for 4 tube installation and single coil + kit not fitted on the unit (YFCC all sizes)		9066562W			-		
2 way DN 10 balance for main coil + kit not fitted (YFCC size 1)		9066650	-		-		
2 way DN 15 balance for main coil + kit not fitted (YFCC sizes 2-3)		-	9066651		-		
2 way DN 10 balance for additional coil + kit not fitted (all sizes)		9066653			-		
Other type of valves		Contact Johnson Controls					
Accessories							
Electrical heater and relays fitted on the unit - 350 W - size 1 - BEL-CCN 1/4 (note 1)		9064051	-		-		
Electrical heater and relays fitted on the unit - 550 W - size 1 - BEL-CCN 1/6 (note 1)		9064031	-		-		
Electrical heater and relays fitted on the unit - 700 W - size 2 - BEL-CCN 2/7 (note 1)		-	9064052		-		
Electrical heater and relays fitted on the unit - 1150 W - size 1 - BEL-CCN 2/12 (note 1)		-	9064032		-		
Electrical heater and relays fitted on the unit - 900 W - size 3 - BEL-CCN 3/9 (note 1)		-	-		9064053		
Electrical heater and relays fitted on the unit - 1400 W - size 1 - BEL-CCN 3/14 (note 1)		-	-		9064033		
Horizontal auxiliary condensate tray HC ACTH-SX (for units with LEFT hydraulic connections)		6060402			-		
Horizontal auxiliary condensate tray HC ACTH-DX (for units with RIGHT hydraulic connections)		6060403			-		
Condensate drain pipe SCR		6060420			-		
Drain condensate pump not fitted PCC-S		9064010			-		
Drain condensate pump fitted PCC-M		9064011			-		
Fresh air spigot 100dia - FCR 100		6064191			-		
Fresh air spigot 120dia - FCR 120		6064192			-		

Compatibility table / Codes

CONTROLS for YFCC (AC versions)	YFCC 130	YFCC 140	YFCC 230	YFCC 240	YFCC 330	YFCC 340
Remote three speed control JWC-3V (1) (5)				9066642		
Remote three speed control + electronic thermostat and manual S/W switch JWC-T (2)				9066330K		
Remote three speed control + electronic thermostat and centralized/manual S/W switch JWC-TQR (2) (4)				9066632K		
Automatic speed control with electronic thermostat and S/W switch - JWC-AU (to be used with JPF-AU and JP-AU only) (2) (4)				9066331E		
Automatic speed control with electronic thermostat to be mounted in the light wall box TMO-503-SV2 (3) (5)				9060172		
Electromechanical thermostat T2T (5) (6)				9060174		
Power unit JPF-AU for JWC-AU and JTM-B remote controls, fitted on the unit				9066641		
Power unit JP-AU for JWC-AU and JTM-B remote controls, not fitted on the unit				9066640		
Control accessories for all versions (supplied with separate packaging)						
Low temperature cut-out for control JWC-T				9053048		
Low temperature cut-out for controls JWC-TQR, JWC-AU and JTM-B				3021090		
T2 sensor to be used as Change-over for controls JWC-AU and JTM-B				9025310		
Change-over 15-25 for control JWC-TQR				9053049		
Receiver SEL2M				9079109		
CONTROLS for YFCC (AC versions) + MB						
Mounted power unit MB-M				9066332		
Not mounted power unit MB-S				9066333		
IR remote control and not mounted IR receiver RS-RT03				9066337		
Not mounted IR receiver RS				9066338		
IR remote control RT03				3021203		
Wall control JTM-B				9066331E		
Multifunction control PSM-DI				3021293		
T2 sensor (to be used as change over or min.temp. sensor) T2				9025310		
CONTROLS for YFCC-ECM						
Automatic speed control with electronic thermostat and S/W switch - JWC-AU (to be used with JPF-AU and JP-AU only) (2) (4)				9066632K		
Automatic remote control with electronic thermostat, S/W switch and liquid crystal display JTM-B (to be used with JPF-AU and JP-AU only) (2) (4)				9066331E		
WM-S-ECM Continuous fan speed control with electronic thermostat, summer/winter switch and LCD display				9066644		
Power unit JPF-AU for JWC-AU and JTM-B remote controls, fitted on the unit				9066641		
Power unit JP-AU for JWC-AU and JTM-B remote controls, not fitted on the unit				9066640		
CONTROLS for YFCC-ECM + MB						
Mounted power unit MB-M				9066332		
Not mounted power unit MB-S				9066333		
IR remote control and not mounted IR receiver RS-RT03				9066337		
Not mounted IR receiver RS				9066338		
IR remote control RT03				3021203		
Wall control JTM-B				9066331E		
Multifunction control PSM-DI				3021293		
T2 sensor (to be used as change over or min.temp. sensor) T2				9025310		
Management system for a network of fan coils with MB electronic board (std. Motor and EC motor)						
Hardware / software supervisory system Net				9079118		
Router S				3021290		
Relay output board SIOS				3021292		
FREE wireless control system for YHKY basic model (AC motor)						
Remote Control FREE-COM				9060572		
Mounted Electronic Board FREE-UPM				9060571		
Not Mounted Electronic Board FREE-UPS				9060570		
Temperature sensor FREE-SEN				9060573		
Low temperature cut out FREE-NTC				3021090		

WARNING

(1) Not to be used with valves and/or low temperature cut-out. (2) It can be used with valves and/or low temperature cut-out. (3) Low temperature cut-out included.

(4) It can be used with Change Over. (5) Not suitable with -E electric heater. (6) Not to be used with low temperature cut-out.

Note 1. Electric heaters must be factory supplied only - in ECM range the above controls can control the electric heater only if there is no hot water supply to the exchanger.

Air Throw

C1 - Heating

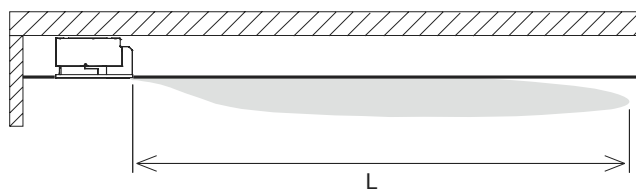

C2 - Cooling

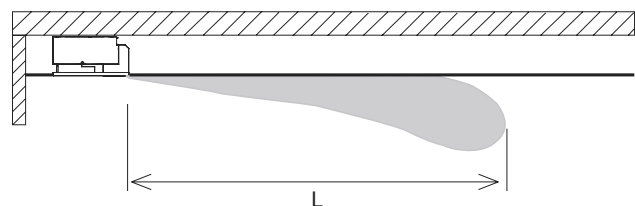

Model	YFCC 1						YFCC 2						YFCC 3						
	1	2	3	4	5	6	1	2	3	4	5	6	1	2	3	4	5	6	
Air throw L (m)	C1	3.8	4.5	5.8	6.3	6.8	7.2	4	5	6.1	7	8	9	4.5	5.2	6.3	7.5	8.8	9.5
	C2	3	3.6	4.6	5	5.4	5.7	3.2	4	4.8	5.6	6.4	7.2	3.6	4.1	5	6	7	7.6

YHVP & YHVP-ECM Hydro High Wall

2 pipe system
A range from 1.17 to 3.81 kW



JWC-T. Wired Control
Remote three speeds controller, electronic thermostat and Summer/Winter switch

JWC-AU. Wired Control
Automatic JWC-T



Electronic Infrared Control



TUC03 Terminal unit controller
BacNET and N2 Metasys network compatible

Features

- Available with standard AC motors or low energy EC motors
- Wired control or infrared control
- Automatic air sweep (-T and -MB variants only)
- Choice of 2 or 3 way valves fitted
- Condensate collection tray
- Air filter included
- Heat exchange coil



2 Way Valve ON/OFF
with thermoelectric actuator.
Suitable for the connection with \varnothing 12 mm pipes

Wired control (YHVP)

- 4 operation modes (Cool/Heat/Auto/Fan)
- Room temperature and setting
- Fan speed selector (Auto, low, medium and high)

Infrared control (YHVP-T)

- Wireless
- 5 operation modes (Cool/Heat/Auto/Dry/Fan)
- Sleep Mode
- Room Temperature setting
- Fan speed selection
- Timer
- Air flow direction setting
- LCD display

Note: model shown is -T variant with automatic air sweep function

YHVP & YHVP-ECM Hydro High Wall

1.17 to 3.81 kW



Technical features

Model		YHVP 1	YHVP 2	YHVP 3	YHVP 4
Total cooling capacity [kW]	(1) max	1.87	2.18	3.03	3.81
	med	1.5	1.84	2.32	3.26
	min	1.24	1.43	1.89	2.62
Sensible cooling capacity [kW]	(1) max	1.46	1.75	2.27	2.98
	med	1.14	1.43	1.69	2.47
	min	0.92	1.07	1.35	1.93
Heating capacity [kW]	(2) max	2.58	3.09	3.86	5.07
	med	2	2.39	2.84	4.20
	min	1.6	1.88	2.26	3.26
Air flow [m ³ /h]	max	375	480	545	790
	med	270	365	375	610
	min	205	250	280	440
Sound power level [dB(A)]	max	48	53	48	57
	med	41	47	40	51
	min	35	39	35	43
Sound pressure level [dB(A)]	(3) max	39	44	39	48
	med	32	38	31	42
	min	26	30	26	34
Power supply [V-ph-Hz]		230V/1ph/50Hz			
Power input [W]	max	30	32	46	48
Absorbed current [A]	max	0.16	0.16	0.23	0.23
Dimensions	Height mm	322	322	322	322
	Width mm	880	880	1 185	1 185
	Depth mm	212	212	212	212

(1) Room temperature 27°C d.b., 19°C w.b. - Water temperature 7/12 °C

(2) Room temperature 20°C - Water inlet temperature: 50°C - Water flow rate as for the cooling conditions.

(3) Sound pressure level in a 100 m² room, at 1,5 m distance and riverberating time of 0,3 s.

* Water flow values as Cooling, accordingly to the EUROVENT standards and UNI ENV 1397

Technical features

Model		YHVP-ECM 1	YHVP-ECM 2	YHVP-ECM 3	YHVP-ECM 4
Total cooling capacity [kW]	(1) max 10v	2.00	2.26	3.29	3.75
	med 5v	1.58	1.87	2.53	3.05
	min 1v	1.17	1.47	1.83	2.34
Sensible cooling capacity [kW]	(1) max	1.57	1.83	2.50	2.92
	med	1.20	1.46	1.86	2.29
	min	0.86	1.10	1.31	1.70
Heating capacity [kW]	(2) max	2.78	3.23	4.25	4.99
	med	2.12	2.58	3.15	3.88
	min	1.50	1.94	2.20	2.87
Air flow [m ³ /h]	max	415	510	620	770
	med	290	375	420	550
	min	190	260	270	375
Sound power level [dB(A)]	max	52	55	53	57
	med	46	47	45	49
	min	37	40	37	43
Sound pressure level [dB(A)]	(3) max	43	46	44	48
	med	37	38	36	40
	min	28	31	28	34
Power supply [V-ph-Hz]		230V/1ph/50Hz			
Power input [W]	max	15	21	20	30
Absorbed current [A]	max	0.14	0.19	0.18	0.26
Dimensions	Height mm	322	322	322	322
	Width mm	880	880	1 185	1 185
	Depth mm	212	212	212	212

(1) Room temperature 27°C d.b., 19°C w.b. - Water temperature 7/12 °C

(2) Room temperature 20°C - Water inlet temperature: 50°C - Water flow rate as for the cooling conditions.

(3) Sound pressure level in a 100 m² room, at 1,5 m distance and riverberating time of 0,3 s.

* Water flow values as Cooling, accordingly to the EUROVENT standards and UNI ENV 1397



Manufacturer reserves the rights to change specifications without prior notice.

Options & Accessories

Codes high wall fan coil units YHVP

Unit without IR control without valve	YHVP 1	YHVP 2	YHVP 3	YHVP 4
Unit codes	0025001K	0025002K	0025003K	0025004K
Unit without IR control with 2 way valve	YHVP-2V 1	YHVP-2V 2	YHVP-2V 3	YHVP-2V 4
Unit codes	0025101K	0025102K	0025103K	0025104K
Unit without IR control with 3 way valve	YHVP-3V 1	YHVP-3V 2	YHVP-3V 3	YHVP-3V 4
Unit codes	0025201K	0025202K	0025203K	0025204K
Unit with IR control without valve	YHVP-T 1	YHVP-T 2	YHVP-T 3	YHVP-T 4
Unit codes	0025021K	0025022K	0025023K	0025024K
Unit with IR control with 2 way valve	YHVP-T-2V 1	YHVP-T-2V 2	YHVP-T-2V 3	YHVP-T-2V 4
Unit codes	0025121K	0025122K	0025123K	0025124K
Unit with IR control with 3 way valve	YHVP-T-3V 1	YHVP-T-3V 2	YHVP-T-3V 3	YHVP-T-3V 4
Unit codes	0025221K	0025222K	0025223K	0025224K
Unit with MB board without valve	YHVP-MB 1	YHVP-MB 2	YHVP-MB 3	YHVP-MB 4
Unit codes	0025011K	0025012K	0025013K	0025014K
Unit with MB board with 2 way valve	YHVP-MB-2V 1	YHVP-MB-2V 2	YHVP-MB-2V 3	YHVP-MB-2V 4
Unit codes	0025111K	0025112K	0025113K	0025114K
Unit with MB board with 3 way valve	YHVP-MB-3V 1	YHVP-MB-3V 2	YHVP-MB-3V 3	YHVP-MB-3V 4
Unit codes	0025211K	0025212K	0025213K	0025214K
Unit without IR control without valve with electrical coil	YHVP-E 1	YHVP-E 2	YHVP-E 3	YHVP-E 4
Unit codes	0025031K	0025032K	0025033K	0025034K
Unit without IR control with 2 way valve with electrical coil	YHVP-E-2V 1	YHVP-E-2V 2	YHVP-E-2V 3	YHVP-E-2V 4
Unit codes	0025131K	0025132K	0025133K	0025134K
Unit without IR control with 3 way valve with electrical coil	YHVP-E-3V 1	YHVP-E-3V 2	YHVP-E-3V 3	YHVP-E-3V 4
Unit codes	0025231K	0025232K	0025233K	0025234K
Unit with IR control without valve with electrical coil	YHVP-T-E 1	YHVP-T-E 2	YHVP-T-E 3	YHVP-T-E 4
Unit codes	0025041K	0025042K	0025043K	0025044K
Unit with IR control with 2 way valve with electrical coil	YHVP-T-E-2V 1	YHVP-T-E-2V 2	YHVP-T-E-2V 3	YHVP-T-E-2V 4
Unit codes	0025141K	0025142K	0025143K	0025144K
Unit with IR control with 3 way valve with electrical coil	YHVP-T-E-3V 1	YHVP-T-E-3V 2	YHVP-T-E-3V 3	YHVP-T-E-3V 4
Unit codes	0025241K	0025242K	0025243K	0025244K
Unit with MB board without valve with electrical coil	YHVP-MB-E 1	YHVP-MB-E 2	YHVP-MB-E 3	YHVP-MB-E 4
Unit codes	0025051K	0025052K	0025053K	0025054K
Unit with MB board with 2 way valve with electrical coil	YHVP-MB-E-2V 1	YHVP-MB-E-2V 2	YHVP-MB-E-2V 3	YHVP-MB-E-2V 4
Unit codes	0025151K	0025152K	0025153K	0025154K
Unit with MB board with 3 way valve with electrical coil	YHVP-MB-E-3V 1	YHVP-MB-E-3V 2	YHVP-MB-E-3V 3	YHVP-MB-E-3V 4
Unit codes	0025251K	0025252K	0025253K	0025254K

Controls

JWM-3V Wall control	9066642
JWC-T Wall control	9066630K
JWC-TQR Wall control	9066631K
TMO-503-SV2 Wall control	9060172
T2T Wall control	9060174
JTM-B Wall control (to be used with MB board only)	9066331E
RT03 infra-red remote control with receiver supplied with separate packaging (to be used with MB board only)	9025301
RT03 infra-red remote control supplied with separate packaging (to be used with MB board only)	3021203
Receiver for RT03 infra-red remote control supplied with separate packaging (to be used with MB board only)	9025300
PSM-DI Multifunction control (to be used with MB board only)	3021293
SEL-CVP Speed switch for controls: JWC-T, JWC-TQR and TMO-503-SV2.	9025302

Electronic control accessories

NTC low temperature cut-out thermostat for control JWC-TQR	3021090
TMM low temperature cut-out thermostat for control JWC-T	9053048
Change-Over CH 15-25 for control JWC-TQR	9053049
T2 Sensor (to be used as change-over or low temperature cut-out - for MB only)	9025310

Options & Accessories

Codes high wall fan coil units YHVP-ECM

Unit without IR control without valve	YHVP-ECM 1	YHVP-ECM 2	YHVP-ECM 3	YHVP-ECM 4
Unit codes	0025501K	0025502K	0025503K	0025504K
Unit without IR control with 2 way valve	YHVP-ECM-2V 1	YHVP-ECM-2V 2	YHVP-ECM-2V 3	YHVP-ECM-2V 4
Unit codes	0025601K	0025602K	0025603K	0025604K
Unit without IR control with 3 way valve	YHVP-ECM-3V 1	YHVP-ECM-3V 2	YHVP-ECM-3V 3	YHVP-ECM-3V 4
Unit codes	0025701K	0025702K	0025703K	0025704K
Unit with IR control without valve	YHVP-ECM-T 1	YHVP-ECM-T 2	YHVP-ECM-T 3	YHVP-ECM-T 4
Unit codes	0025521K	0025522K	0025523K	0025524K
Unit with IR control with 2 way valve	YHVP-ECM-T-2V 1	YHVP-ECM-T-2V 2	YHVP-ECM-T-2V 3	YHVP-ECM-T-2V 4
Unit codes	0025621K	0025622K	0025623K	0025624K
Unit with IR control with 3 way valve	YHVP-ECM-T-3V 1	YHVP-ECM-T-3V 2	YHVP-ECM-T-3V 3	YHVP-ECM-T-3V 4
Unit codes	0025721K	0025722K	0025723K	0025724K
Unit with MB board without valve	YHVP-ECM-MB 1	YHVP-ECM-MB 2	YHVP-ECM-MB 3	YHVP-ECM-MB 4
Unit codes	0025511K	0025512K	0025513K	0025514K
Unit with MB board with 2 way valve	YHVP-ECM-MB-2V 1	YHVP-ECM-MB-2V 2	YHVP-ECM-MB-2V 3	YHVP-ECM-MB-2V 4
Unit codes	0025611K	0025612K	0025613K	0025614K
Unit with MB board with 3 way valve	YHVP-ECM-MB-3V 1	YHVP-ECM-MB-3V 2	YHVP-ECM-MB-3V 3	YHVP-ECM-MB-3V 4
Unit codes	0025711K	0025712K	0025713K	0025714K
Unit without IR control without valve with electrical coil	YHVP-ECM-E 1	YHVP-ECM-E 2	YHVP-ECM-E 3	YHVP-ECM-E 4
Unit codes	0025531K	0025532K	0025533K	0025534K
Unit without IR control with 2 way valve with electrical coil	YHVP-ECM-E-2V 1	YHVP-ECM-E-2V 2	YHVP-ECM-E-2V 3	YHVP-ECM-E-2V 4
Unit codes	0025631K	0025632K	0025633K	0025634K
Unit without IR control with 3 way valve with electrical coil	YHVP-ECM-E-3V 1	YHVP-ECM-E-3V 2	YHVP-ECM-E-3V 3	YHVP-ECM-E-3V 4
Unit codes	0025731K	0025732K	0025733K	0025734K
Unit with IR control without valve with electrical coil	YHVP-ECM-T-E 1	YHVP-ECM-T-E 2	YHVP-ECM-T-E 3	YHVP-ECM-T-E 4
Unit codes	0025541K	0025542K	0025543K	0025544K
Unit with IR control with 2 way valve with electrical coil	YHVP-ECM-T-E-2V 1	YHVP-ECM-T-E-2V 2	YHVP-ECM-T-E-2V 3	YHVP-ECM-T-E-2V 4
Unit codes	0025641K	0025642K	0025643K	0025644K
Unit with IR control with 3 way valve with electrical coil	YHVP-ECM-T-E-3V 1	YHVP-ECM-T-E-3V 2	YHVP-ECM-T-E-3V 3	YHVP-ECM-T-E-3V 4
Unit codes	0025741K	0025742K	0025743K	0025744K
Unit with MB board without valve with electrical coil	YHVP-ECM-MB-E 1	YHVP-ECM-MB-E 2	YHVP-ECM-MB-E 3	YHVP-ECM-MB-E 4
Unit codes	0025551K	0025552K	0025553K	0025554K
Unit with MB board with 2 way valve with electrical coil	YHVP-ECM-MB-E-2V 1	YHVP-ECM-MB-E-2V 2	YHVP-ECM-MB-E-2V 3	YHVP-ECM-MB-E-2V 4
Unit codes	0025651K	0025652K	0025653K	0025654K
Unit with MB board with 3 way valve with electrical coil	YHVP-ECM-MB-E-3V 1	YHVP-ECM-MB-E-3V 2	YHVP-ECM-MB-E-3V 3	YHVP-ECM-MB-E-3V 4
Unit codes	0025751K	0025752K	0025753K	0025754K

Controls

JTM-B Wall control (to be used with MB board only)	9066331E
RT03 infra-red remote control with receiver supplied with separate packaging (to be used with MB board only)	9025301
RT03 infra-red remote control supplied with separate packaging (to be used with MB board only)	3021203
Receiver for RT03 infra-red remote control supplied with separate packaging (to be used with MB board only)	9025300
PSM-DI Multifunction control (to be used with MB board only)	3021293
SEL-CVP Speed switch for controls: JWC-T, JWC-TQR and TMO-503-SV2.	9025302
Electronic control accessories	
T2 Sensor (to be used as change-over or low temperature cut-out - for MB only)	9025310

YORK® Close Control units

Maintaining a constant temperature, purity and humidity of air is essential for ensuring a stable environment for critical electronic and computer equipment, this is why there is the need for close control air conditioning. Unlike comfort air conditioning, close control systems must operate constantly 24/7 requiring high reliability and minimal power consumption. Johnson Controls knows that no two close control requirements are the same, this is why the YORK® range of custom close control units offers quiet, compact and energy efficient equipment that can be configured to needed requirements.

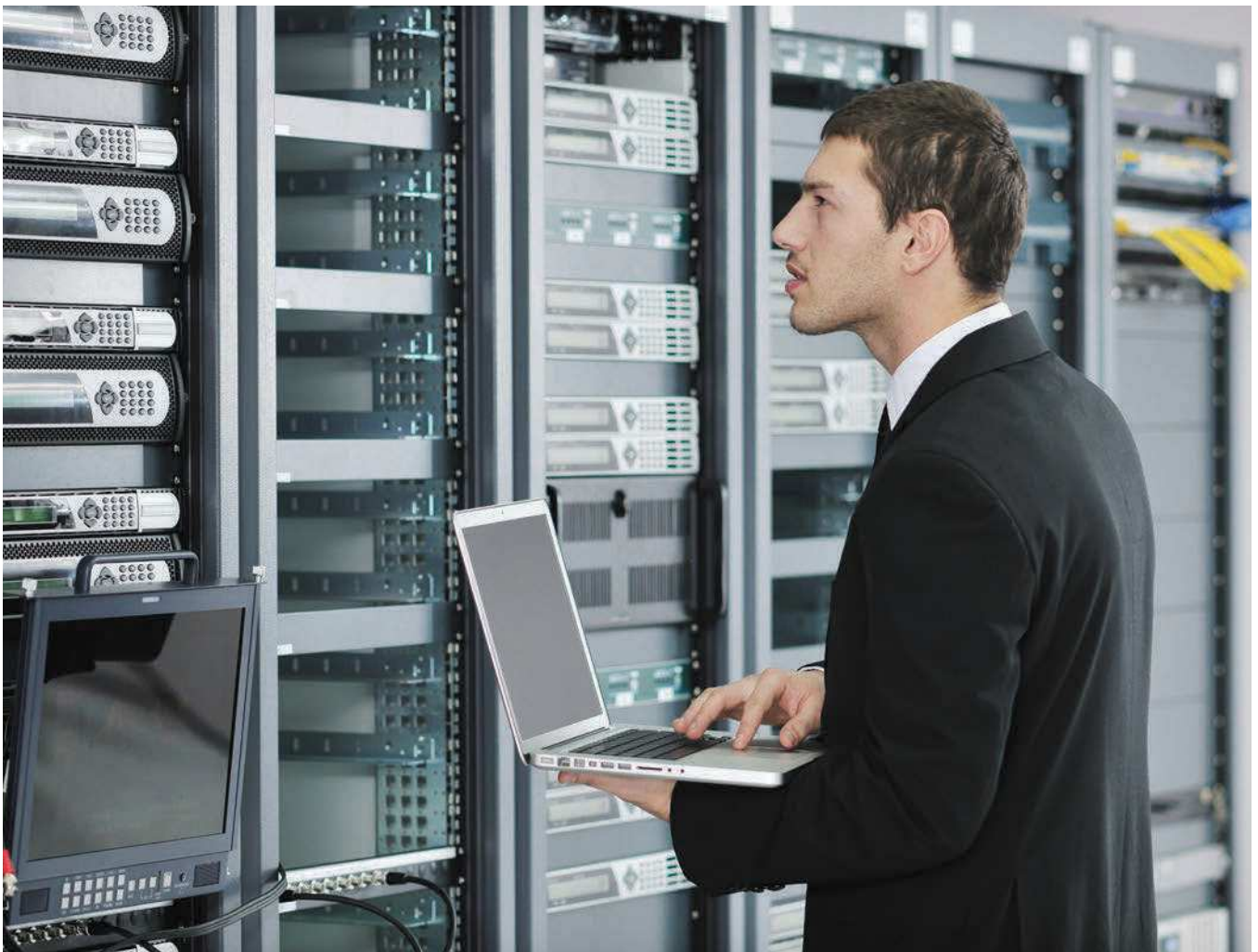

An extensive offering

- cooling capacities of **up to 160kw (chilled water) or 94kw (direct expansion)** with optional free cooling models. Up flow or down flow configuration, either as self-contained packaged units or suitable for connection to remote condensers, are also available
- **optional direct expansion units** fitted with scroll compressors, which have much lower noise and energy consumption than reciprocating compressors
- **R410a** refrigerant units available
- optional **Free Cooling coil** to reduce energy consumption required through use of mechanical cooling
- plug fan with **Electronically Commuted 'EC' fans** option, to allow fully modulating control of airflow
- **low component face velocities**, for a lower total pressure drop and reduced energy consumption
- **minimised dimensions**, enabling one of the market's greatest ratios between sensible cooling capacity and base foot print



YORK® YC-P Series Close Control Air Conditioners

A complete range from 7.7 kW up to 160 kW



High energy efficiency and minimum environmental impact

"P" Series air conditioners for close control applications are specialised machines with design and operating features which clearly differentiate them from standard air conditioning units.

The **"P" Series** air conditioners offer very high energy efficiency values in all operating conditions which translates into less CO₂ emissions and particularly low running costs. Though optimised for use in data centers and telephone exchanges, they are equally valid in special applications such as measurement laboratories, TV recording studios, museums, control rooms for electricity power stations and railway junctions and other areas where there are prevalent sensible thermal loads and crowding is negligible.

Their application is also ideal in widely varied industrial sectors: optics, electronics, electromedical equipment, electronic equipment production, musical instrument production etc.

Optimal efficiency

Johnson Controls' **"P" Series** design offers the highest sensible cooling capacity with the minimum footprint possible, which translates into optimal ratio levels of cooling capacity to footprint area. This is an important feature in reducing the space needed by machinery, allowing more room in the space for IT equipment. This advantage is especially important given the progressive increases in capacity required by data centers and other computer applications which, over time, need the addition of extra air conditioners.

Clean efficiency is also ensured by the use of the R-410A refrigerant, respectful to the ozone layer.

"P" Series units are also available in configurations 'PG' for perimeter installation, or 'PR' for in row installation in large data centres.

Features and performance

Brushless DC compressors with inverter technology

- Adapting cooling capacity to the real requirements of the plant is one of the principal conditions of guaranteeing the flexibility required by the most advanced systems. By incorporating **BRUSHLESS DC INVERTER** technology into the compressors it is possible to maximize the performance of the motor, especially at partial loads, the control of which is integrated in the microprocessor.
- The cooling coils of the downflow units (**YC-UP**), both in chilled water and direct expansion versions, have aluminium fins with a hydrophylic treatment that alleviates the risk of condensation and the coil face being covered with water, which would compromise the thermal performance and therefore the air conditioning capacity.
- The use of the environmentally friendly refrigerant HFC R410A does not contribute to the depletion of the ozone layer (R134a available on request).
- Thanks to its larger surface area, the filter on the coil allows lower face velocity, which results in lower pressure drop.
- The lower energy consumption of these air conditioners, at the same efficiency, results in a much reduced TEWI (Total Equivalent Warming Impact). The application of EC plug fans reduces both energy consumption and noise levels.



Downflow unit with 2 fans and side compartment; full front access for both fans (covered) and technical compartment



Downflow unit with 2 fans and side compartment; full front access for both fans (not covered) and technical compartment on the side. No side maintenance space is required for accessing components

Microprocessor regulation

The Standard digital microprocessor

- allows management of all typical air-conditioning functions: cooling, heating, humidification, dehumidification and filtering
- ensures a regular and optimised operation as to both performance and consumption, providing as well alarm management and self-diagnosis
- in case of need to install any component requiring analogue control (modulating valve or electronic hot-gas by-pass valve), an optional modulating controller, with semigraphic display, shall be installed in lieu of standard. This alternative controller is also installed as standard microprocessor on special versions such as "Free cooling", "Two Sources" and "Fresh air" units.

Local network management or remote control

YORK® YC-P Series air conditioners are capable of standalone operation, local private network with multiple units (up to 12) or fully integrated with Metasys® Building Management System from Johnson Controls.

In local network applications, one machine is the master, and the remaining slaves follow the same algorithm. The slave units are rotated at predetermined intervals and switch to the master role to balance the number of working hours of the compressors.

In remote applications, the machines can be controlled from remote positions interfacing with common Building Management Protocols such as BacNET, LON and Modbus, either via GSM Modem or TCP/IP Internet Protocol.

For total integration with Johnson Control Metasys® Building Management Systems (BMS) the units can be equipped with an RS485 card working with BacNET MS/TP protocol.

Cooling circuit

The air conditioners with direct expansion coil have a frigorific circuit equipped with: scroll compressor with all necessary protective devices, high pressure (manual reset) and low pressure (automatic reset) switches, thermal expansion valve, dehydrating filter with refrigerant sight glass.

YC-OPA, YC-UPA models for pairing with remote condensers, are already equipped with a pressurisation nitrogen charge. The refrigerant charge, and the oil top-up (if required), shall be made by the installer on site.

YC-OPA and **YC-UPA** air conditioners in self-contained packaged format with built-in water-cooled condensers (accessory), are supplied with full refrigerant and oil charge.



Manufacturer reserves the rights to change specifications without prior notice.

Electronic expansion valve (*)

Electronic expansion valves are one of the most recent pieces of equipment that enable us to improve the energy efficiency at partial loads of direct expansion machines. These valves are installed at the inlet of the evaporator, substituting the traditional thermostatic expansion ones: this allows more precise control of the quantity of refrigerant entering the evaporator, and guarantees good capacity regulation, typically between 100% and 50%. Electronic expansion valves also allows control of the amount of overheated gas at the outlet of the evaporator, thus allowing a significant reduction of the condensation pressure during winter or night-time operation whilst maintaining the evaporation pressure unchanged. Adoption of the electronic expansion valve (optional) guarantees a significant increase of the EER values.

One or two completely independent compressors

Models with "1" as the last digit of the unit model number have a single circuit and a single compressor. Those with "2" as the last digit on the other hand have two completely independent refrigerant circuits and two compressors.

The circuits are fitted with all the safety and regulation devices necessary for efficient and reliable operation.

The evaporator coil can be single or double circuit depending on the number of compressors.

Hydraulic circuit

Air conditioners with chilled water coil, **YC-OPU** and **YC-UPU**, include a finned coil and a three-way throttling motorised valve for water flow regulation. The hydraulic circuit is provided with copper tubes with anti-condensate insulation. The coils are optimised for both water with a temperature of 7/12 and for higher ones such as 15/20.

The standard throttling valve (3 points) allows good modulation of the cooling capacity as a function of the environmental conditions, especially with constant thermal loads.

Modulating regulation of the cooling capacity (**)

If a very precise regulation and high response speed are required, a modulating valve (optional) can be installed in lieu of the throttling one. The installation of this valve is recommended in case of functionment with a lot of fresh air. However, the modulating valve needs an analogue signal, not digital, so the installation of the optional modulating controller is necessary.

(*) units equipped with frigorific circuit
(**) units equipped with chilled water coil

Control Panel

All the units are equipped with a complete control panel with main isolator switch. Magnetothermic switches, contactors, and all necessary protection is provided, as required by legal codes and standards.

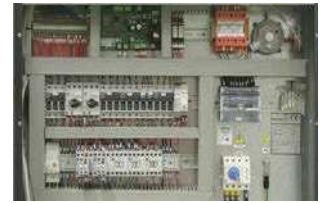

The control panel of the units equipped with compressors ("A" as third letter of the identification code) has as standard a phase sequencer, which prevents the compressor from getting damaged when counter running. Also, the control panel has two spare terminals for remote indication of a cumulative alarm, as well as two terminals for starting up and stopping the unit from remote position.

The control panel does not include the fan speed controller(s) for the fans of the air cooled remote condensers (winter control). This device is included as standard in the CEA and CEA/LN air cooled condensers from Johnson Controls.

Should you decide to match the unit with a condenser from another manufacturer, the controller(s) can be ordered as accessory.



Modulating controller display and keypad

Large surface filters

The units are equipped with self-extinguishing media class G4 filters. The filters are installed inclined before the cooling coil in order to offer a larger surface and allow lower air crossing speeds, with lower energy consumption.

A 450 mm high duct (accessory) can be installed for holding a F7 class filter, vertically on supply air discharge.

Design suitable to civil environments

YORK® YC-P Series air conditioners have a pleasant and functional design, suitable for installation in civil environments. Their structure consists of aluminium profiles and closing panels hinged on them. Both panels and profiles are coated with a dark grey PVC layer (anthracites), thermoacoustically insulated by polyurethane layer, and further coated with an anti scratch plastic film.

Two versions are available for up flow units (**YC-OP**): front grille & top air discharge (standard), or blind front panel, suction from the bottom and top discharge (optional).

Fan section

New generation of electronic fans

The ever-growing necessity to save energy has made the use of high-performance EC Plug Fans indispensable in reducing plant costs. The fans installed in **YC-P** close control air conditioners are fitted with **BRUSHLESS EC** (Electronically Commutated) **MOTORS** and a composite-material impeller to maximize performance.

Important advantages obtained as a result include:

- Power drawn by the fans is reduced by over 25% compared to fans using traditional AC technology.
- Power drawn by the fans is reduced by about 15% compared to the previous generation of EC fans.
- Noise levels are reduced by over 5 dB(A) at partial loads.
- Risk to the plant is reduced as the mechanical parts are subjected to less use.

Thanks to integration with the microprocessor, the EC fans can be controlled to:

- Reduce rotation speed and therefore air quantity as the cooling capacity requirement decreases, thus making possible a 50% energy saving, operating at partial loads, compared to a constant velocity system.
- Maintain constant air quantity controlled in real time by differential pressure sensors, optimal control if F7 filters are installed.
- Maintain constant air pressure in the raised floor or in the compartmented areas in order to optimize air distribution avoiding hot spots and guarantee maximum modularity of the plant.

Regulation Options

Johnson Controls provides four different alternatives for the regulation of the airflow of the EC fans depending on the requirements of the installation:

1. Constant fan rotation speed. The available high static pressure is ideal for most applications. The effective air flow depends on the real pressure drop of the aerodynamic system of the installation, however it can be calculated through Johnson Controls computerised selection program.
2. Constant airflow independent of the pressure drop of the filters. In order to maintain a constant airflow, an internal sensor guides the microprocessor management system to vary the airflow handled by the fan, depending on the degree of clogging of the filters. This ensures that insufficient cooling does not occur due to reduced airflow arising from dirty filters.
3. Variable airflow depending on the cooling capacity required by the installation. This is the classic VAV (Variable Air Volume) plant arrangement which responds to increased demand by a proportionate increase in airflow and vice versa. This type of plant offers interesting energy advantages at partial loads, which occur extensively throughout the year, especially at night.
4. Airflow as a function of pressure in the raised floor. This regulation alternative is envisaged for plants with raised floors where the air is distributed under the floor itself. The microprocessor management system maintains constant under-floor pressure. In particular, in very large areas subdivided into multiple local zones with partition dampers driven by individual thermostats, constant regulation of the pressure is necessary to avoid imbalances in the distribution of the air.

Special versions

“Water to air free cooling”: using renewable energy sources

YC-OPW.../FC, YC-UPW.../FC air conditioners are equipped with a “Free cooling” system consisting of an additional chilled-water cooling coil integrated in the aluminium fins of the unit’s direct expansion one, with a three-way modulating valve controlled by the modulating controller. As long as the outside conditions allow the water to respond totally or partially to the cooling request, the controller cuts out or minimises the compressors’ intervention, so reducing substantially the energy consumption.

The water cooled condensers of the frigorific circuit are equipped with a pressostatic system for the regulation of the condensing pressure (flooding valves).

The pumps and the expansion tank are not included in Johnson Control’s supply. Units in “free cooling” version cannot install the optional hot water heating coil, only the electric one, and have as standard the analogue modulating controller. The system widely uses the outdoor air—a renewable energy source—in lieu of or in addition to the mechanical cooling.

‘Two Sources’ option utilising excess energy from building HVAC systems

This system consists of the same chilled-water cooling coil as the “Free cooling”, but fed by the building water chiller. A built in frigorific circuit enters in operation in case of lack of chilled water. The result is the maximum security or a remarkable reduction of both consumption and running costs. This system can also use the direct-expansion coil circuit as primary cooling source and, in case of an emergency, the chilled-water coil connected with the tap water network.

The “Two Sources” version is available for units with direct expansion circuit **YC-OPA.../TS, YC-UPA.../TS** as well as units with built in water cooled condenser (accessory) and with double chilled water coil **YC-OPU.../TS, YC-UPU.../TS**: one for district water and the other for tap water or water from a chiller (emergency).

Units in “Two Sources” cannot install the optional hot water heating coil, only the electric one, and have as standard the analogue modulating controller.



50 kW upflow 2 circuits direct expansion air conditioner

Fittings and accessories

Numerous accessories and options are available for the **"P" Series** air conditioners to personalise the installation depending on the requirements of the plant and its design. Divided by function, they include:

Free cooling or two sources

- Additional Free cooling circuit.
- Additional Two sources circuit.

Alarms

- Water alarm (supplied loose).
- Out-of-range air discharge temperature alarm.
- Smoke/fire alarm terminals.

Water cooled condensers and pressostatic valves

- Welded stainless steel water cooled plate condenser.
- 2 way pressostatic valve (only if the water condenser is selected).

Sound proofing devices

- Sound damped duct for air suction or discharge (h=550 mm). Allows a reduction of approx 4 dB(A) of the SPL of the unit.
- Double layer sound damping panels. Reduces SPL by approx 2 dB(A) in upflow units (OP series), and approx.4 dB(A) in downflow units ((UP series).
- Double-layer "sandwich" thermo-acoustic insulation panels.

Panels and base

- Blind front panel (OP) and open base for bottom air intake.
- Front panel with grille in the lower part (UP) and closed base.

Plenum

- Plenum (h=550 mm) for air discharge or intake with front grille.
- Plenum (h=550 mm) for air discharge or intake with front and side grilles.

Direct expansion unit cooling capacity regulation

- Electronic expansion valve.
- Electronic hot-gas injection system for the regulation of cooling capacity (100-10%).

Heating, reheating and humidification

- Single-step or double-step low thermal inertia electrical heating/reheating coil.
- Immersed-electrode modulating humidifier and dehumidification control.
- Humidity sensor for the single control of dehumidification.

Boards and sensors

- Humidity sensor and board for external humidification control not supplied by Johnson Controls.
- RS 485 communication board.

Dampers

- Gravity-operated overpressure dampers on the air outlet (OP series).
- Motorised overpressure dampers on the air intake (UP series).

Under bases

- Adjustable under base (OP only). (*Precise height to be specified with order*).
- Adjustable under base with air deflector (UP only). (*Precise height to be specified with order*).

Fans and filters

- Electronic EC fans with incorporated inverter for constant rotation speed regulation.
- Electronic EC fans with incorporated inverter for the regulation of air flow in relation to the required cooling capacity.
- Electronic EC fans with incorporated inverter for the regulation of constant pressure in the raised floor.
- Electronic two-speed AC fans.
- F7 filter to be installed on the air intake as substitute for the standard G4.
- Monophase condenser-fan rotation speed variator

Performance at JOHNSON CONTROLS test conditions*

Technical Characteristics

YC-OPA: direct expansion air conditioners with air cooled or water condensers and up-flow air supply																		
Models		71	111	141	211	251	301	302	361	372	422	461	491	512	612	662	852	932
Performances																		
Total cooling capacity	kW	7.7	11.1	14.5	20.8	25.3	31.2	30.6	36.6	38.8	42.7	46.9	52.3	51.6	63.2	67.7	87.3	94.2
Sensible cooling capacity	kW	7.4	11.1	12.8	20.8	22.7	30.3	30.1	36.6	33.6	42.7	45.3	52.3	47.4	62.6	64.5	73.2	85.4
Airflow	m ³ /h	2 200	3 200	3 200	7 000	7 000	8 700	8 700	14 500	8 700	14 500	14 500	17 900	14 500	17 900	17 900	17 900	20 700
EER		3.69	3.26	3.36	3.12	3.06	3.13	3.20	3.24	3.03	3.22	3.37	3.47	3.14	3.21	3.17	3.29	3.59
Sound pressure level	dB(A)	51	57	57	62	62	60	60	65	65	65	65	62	65	62	62	62	60
Dimensions & weight																		
Lenght	mm	750	750	750	860	860	1 410	1 410	1 750	1 410	1 750	1 750	2 300	1 750	2 300	2 300	2 300	2 640
Depth	mm	601	601	601	880	880	880	880	880	880	880	880	880	880	880	880	880	880
Height	mm	1 990	1 990	1 990	1 990	1 990	1 990	1 990	1 990	1 990	1 990	1 990	1 990	1 990	1 990	1 990	1 990	1 990
Net weight	kg	180	200	210	270	270	320	340	440	350	450	450	540	500	640	640	660	860
Free Cooling		○	○	○	○	○	●	●	○	●	○	○	●	○	●	●	●	○
Two Sources		○	○	○	○	○	●	●	○	●	○	○	●	○	●	●	●	○

* Performance refers to: R410a refrigerant; condensing temperature 45°C; incoming air 24°C-45%Rh; water 7/12°C; external static pressure 30 Pa. The declared performance does not take into account the heat generated by fans, which must be added to the system thermal load.
 EER (Energy Efficiency Ratio) = total cooling capacity / compressors power consumption + fans power consumption (air cooled condensers excluded).
 Sound levels at a 2 m distance, in a free field, as per UNI EN ISO 3744:2010.

Technical Characteristics

YC-UPA: direct expansion air conditioners with air cooled or water condensers and down-flow air supply																		
Models		71	111	141	211	251	301	302	361	372	422	461	491	512	612	662	852	932
Performances																		
Total cooling capacity	kW	7.7	11.1	14.5	20.8	25.3	31.2	30.6	36.6	38.8	42.7	46.9	52.3	51.6	63.2	67.7	87.3	94.2
Sensible cooling capacity	kW	7.4	11.1	12.8	20.8	22.7	30.3	30.1	36.6	33.6	42.7	45.3	52.3	47.4	62.6	64.5	73.2	85.4
Airflow	m ³ /h	2 200	3 200	3 200	7 000	7 000	8 700	8 700	14 500	8 700	14 500	14 500	17 900	14 500	17 900	17 900	17 900	20 700
EER		3.69	3.25	3.36	3.12	3.06	3.13	3.20	3.24	3.03	3.22	3.37	3.47	3.14	3.21	3.17	3.29	3.59
Sound pressure level	dB(A)	51	57	57	62	62	60	60	65	60	65	65	62	65	62	62	62	60
Dimensions & weight																		
Lenght	mm	750	750	750	860	860	1 410	1 410	1 750	1 410	1 750	1 750	2 300	1 750	2 300	2 300	2 300	2 640
Depth	mm	601	601	601	880	880	880	880	880	880	880	880	880	880	880	880	880	880
Height	mm	1 990	1 990	1 990	1 990	1 990	1 990	1 990	1 990	1 990	1 990	1 990	1 990	1 990	1 990	1 990	1 990	1 990
Net weight	kg	180	200	210	270	270	320	340	440	350	450	450	540	500	640	640	660	860
Free Cooling		○	○	○	○	○	●	●	○	●	○	○	●	○	●	●	●	○
Two Sources		○	○	○	○	○	●	●	○	●	○	○	●	○	●	●	●	○

* Performance refers to: R410a refrigerant; condensing temperature 45°C; incoming air 24°C-45%Rh; water 7/12°C; external static pressure 30 Pa. The declared performance does not take into account the heat generated by fans, which must be added to the system thermal load.
 EER (Energy Efficiency Ratio) = total cooling capacity / compressors power consumption + fans power consumption (air cooled condensers excluded).
 Sound levels at a 2 m distance, in a free field, as per UNI EN ISO 3744:2010.

Performance at JOHNSON CONTROLS test conditions*

Technical Characteristics

YC-OPU: with chilled water coil and up-flow air supply									
Models		10a	20a	30	50	80	110	160	220
Performances									
Total cooling capacity	kW	10.0	18.0	32.4	43.6	66.8	80.2	121.9	160.3
Sensible cooling capacity	kW	9.2	15.4	29.8	38.1	62.1	72.0	109.7	144.0
Airflow	m ³ /h	2 200	3 200	7 400	8 200	15 400	17 000	26 000	34 000
EER		34.42	29.24	22.83	21.48	23.94	24.30	23.62	24.29
Sound pressure level	dB(A)	51	57	63	59	66	61	63	64
Dimensions & weight									
Lenght	mm	750	750	860	860	1 750	1 750	2 640	3 495
Depth	mm	601	601	880	880	880	880	880	880
Height	mm	1 990	1 990	1 990	1 990	1 990	1 990	1 990	1 990
Net weight	kg	155	160	220	240	340	360	540	700
Free Cooling		○	○	○	●	○	●	●	○
Two Sources		○	○	○	●	○	●	●	○

* Performance refers to: R410a refrigerant; condensing temperature 45°C; incoming air 24°C–45%Rh; water 7/12°C; external static pressure 30 Pa. The declared performance does not take into account the heat generated by fans, which must be added to the system thermal load.

EER (Energy Efficiency Ratio) = total cooling capacity / compressors power consumption + fans power consumption (air cooled condensers excluded).

Sound levels at a 2 m distance, in a free field, as per UNI EN ISO 3744:2010.

Technical Characteristics

YC-UPU: with chilled water coil and down-flow air supply									
Models		10	20	30	50	80	110	160	220
Performances									
Total cooling capacity	kW	10.2	18.0	32.4	43.6	66.8	80.2	121.9	160.3
Sensible cooling capacity	kW	9.2	15.4	29.8	38.1	62.1	72.0	109.7	144.0
Airflow	m ³ /h	2 200	3 200	7 400	8 200	15 400	17 000	26 000	34 000
EER		34.42	28.98	22.82	21.48	23.95	24.29	23.62	24.29
Sound pressure level	dB(A)	51	57	63	59	66	61	63	64
Dimensions & weight									
Lenght	mm	750	750	860	860	1 750	1 750	2 640	3 495
Depth	mm	601	601	880	880	880	880	880	880
Height	mm	1 990	1 990	1 990	1 990	1 990	1 990	1 990	1 990
Net weight	kg	155	160	220	240	340	360	540	700
Free Cooling		○	○	○	●	○	●	●	○
Two Sources		○	○	○	●	○	●	●	○

* Performance refers to: R410a refrigerant; condensing temperature 45°C; incoming air 24°C–45%Rh; water 7/12°C; external static pressure 30 Pa. The declared performance does not take into account the heat generated by fans, which must be added to the system thermal load.

EER (Energy Efficiency Ratio) = total cooling capacity / compressors power consumption + fans power consumption (air cooled condensers excluded).

Sound levels at a 2 m distance, in a free field, as per UNI EN ISO 3744:2010.

YORK® YC-G Series Close Control Air Conditioners

A complete range from 43 kW up to 183.5 kW



Applications

"G" Series YORK air conditioners consist of a family of units specially designed to exploit the plant characteristics of the latest generation of large Data Centres.

In the design of air conditioning equipment for large Data Centres, the necessities of cable housing and for the distribution of the enormous quantities of air required to cool the servers have made it necessary to raise the height of the false floor to now reach the current 600–800 millimetres. This creates an ample space below the air conditioner destined to the installation of the plinth. This large space under the raised floor was therefore considered as the housing for the discharge fans. The air conditioners are supplied in two separate sections: the under-base containing the discharge fans to be installed under the floating floor, and the treatment unit with the exchanger coil, filters and the electrical panel.

This large space under the raised floor is used to house the supply air fans. The air conditioners are therefore supplied in two separate sections:

- The treatment unit with enlarged heat exchanger coil, filters and electrical panel.
- The plinth containing the supply air fans, to be installed under the raised floor. The plinth with the fans is supplied to match the height indicated in the order from the customer.

The two sections, shipped separately, are easy to install on-site as they require only electrical connection of the two junction boxes in the air conditioner and the plinth.

Downflow supply



Standard version for perimeter installation inside the Data Centre: the height of the raised floor must be minimum 550 mm.



Version for perimeter installation inside the Data Centre with raised floor height less than 550 mm. In this case, the plinth with fixed height of 550 mm is supplied with lateral closure panels and must be installed above the floor. It is essential to check that the height of the ceiling is sufficient to ensure good air suction.



Version for installation outside the Data Centre, without raised floor, rear air supply. In this case the plinth (fixed height 550 mm) is supplied with side closure panels and rear supply air grilles. Installation of the plenum with rear re-intake system is optional, if there is no ductwork.

Technical Characteristics

YC-UGA: direct expansion air conditioners with air-cooled or water-cooled condensers and downflow air supply				
Models		461	612	932
Total cooling capacity (1)	kW	43.0	54.9	91.7
Sensible cooling capacity (1)	kW	35.9	42.1	79.4
EER (3)		3.39	2.86	3.60
Total cooling capacity (2)	kW	46.6	58.8	99.6
Sensible cooling capacity (2)	kW	46.6	53.1	99.6
EER (3)		3.67	3.07	3.92
Airflow	m ³ /h	9 500	10 000	19 000
Sound pressure level (4)	dB(A)	57	58	59
Length	mm	1 490	1 490	2 390
Depth	mm	921	921	921
Height	mm	1 990	1 990	1 990
Net weight	kg	630	680	870

YC-UGU: chilled water coil air conditioners with downflow air supply					
Models		70	150	230	300
Total cooling capacity (1)	kW	47.7	91.7	128.3	183.5
Sensible cooling capacity (1)	kW	42.1	82.6	119.9	165.3
EER (3)		32.89	33.97	35.15	40.77
Total cooling capacity (2)	kW	38.5	74.9	106.7	149.8
Sensible cooling capacity (2)	kW	38.5	74.9	106.7	149.8
EER (3)		27.7	28.69	29.81	34.51
Airflow	m ³ /h	9 500	19 000	28 500	38 000
Sound pressure level (4)	dB(A)	57	59	61	60
Length	mm	1 320	2 220	3 120	4 020
Depth	mm	921	921	921	921
Height	mm	1 990	1 990	1 990	1 990
Net weight	kg	610	750	930	1 250

- (1) Performance refers to: R410a refrigerant; condensing temperature 45°C; incoming air 24°C-45%Rh; water 7/12°C; external static pressure 30 Pa, ventilated plenum, height 1000 mm. The declared performance does not take into account the heat generated by fans, which must be added to the system thermal load.
- (2) Performance refers to: R410a refrigerant; condensing temperature 45°C; incoming air 30°C-30%Rh; water 14/20°C; external static pressure 30 Pa, ventilated plenum, height 1000 mm. The declared performance does not take into account the heat generated by fans, which must be added to the system thermal load.
- (3) EER (Energy Efficiency Ratio) = total cooling capacity / compressors power consumption + fans power consumption (air cooled condensers excluded).
- (4) Sound levels at a 2 m distance, in a free field, as per UNI EN ISO 3744:2010.



Manufacturer reserves the rights to change specifications without prior notice.

YORK® YC-R Series Close Control Air Conditioners

A complete range from 20.6 kW up to 36.2 kW



Applications

"R" Series YORK air conditioners consist of a family of units specially designed and constructed to have the same dimensions as the racks.

In the design of air conditioning plant for large Data Centres, the reduction of energy consumption is of ever increasing importance. For this reason the following concepts have become consolidated international standard practice:

- The racks containing the servers are more often positioned according to the "hot corridor aisle" and "cold corridor/aisle" layout.
- The working air temperatures are now allowed to go up to 30-35°C in the hot corridor and 20-25°C in the cold one, with very low humidity (never above 30%). Consequently, also the water temperature is allowed to rise up to 20-28°C, using the Free Cooling system to the best effect.
- Server capacities keep going up while their dimensions keep going down. This means that more servers can be installed in a rack so that some of these racks, remaining empty, can be removed. At the same time the heat dissipated rises and more capacity is required from the air conditioners.
- The servers work day and night albeit with a night time reduction of their capacity. It is therefore essential for the air conditioning installation to have an efficient modulating cooling capacity control and to be designed for minimum energy consumption and minimum environmental impact.

Horizontal supply



Version for in-row installation with front and lateral air supply.

Technical Characteristics

YC-HRA: direct expansion air conditioners with air-cooled or water-cooled condensers and horizontal air supply			
Models		231	361
Total cooling capacity (1)	kW	20.6	36.2
Sensible cooling capacity (1)	kW	20.6	35.6
EER (2)		3.31	3.65
Airflow	m ³ /h	6 500	7 500
Sound pressure level (3)	dB(A)	52	54
Length	mm	600	600
Depth	mm	1 180	1 180
Height	mm	2 000	2 000
Net weight	kg	215	215
Free Cooling		●	○
Two Sources		●	○

YC-HRU: chilled water coil air conditioners with horizontal air supply		
Models		40
Total cooling capacity (1)	kW	31.6
Sensible cooling capacity (1)	kW	31.6
EER (3)		26.58
Airflow	m ³ /h	9 000
Sound pressure level	dB(A)	61
Length	mm	600
Depth	mm	1 180
Height	mm	2 000
Net weight	kg	190
Free Cooling		●
Two Sources		●

(1) Performance refers to: R410a refrigerant; condensing temperature 45°C; incoming air 30°C-30%Rh; water 14/20°C; external static pressure 30 Pa. The declared performance does not take into account the heat generated by fans, which must be added to the system thermal load.

(2) EER (Energy Efficiency Ratio) = total cooling capacity / compressors power consumption + fans power consumption (air cooled condensers excluded).

(3) Sound levels at a 2 m distance, in a free field, as per UNI EN ISO 3744:2010.



Manufacturer reserves the rights to change specifications without prior notice.

SmartPac

SmartPac from Johnson Controls offers factory packaged control solutions that reduce cost, enhance quality and optimise site time.

Once on site, the equipment can be started immediately. Commissioning time is dramatically reduced, allowing to better control the project costs through simplifying equipment installation and commissioning.

Quality is ensured through application and testing to European Installation regulations at the factory. Pre-installed software is configured to deliver air at the specified volume, temperature and humidity.

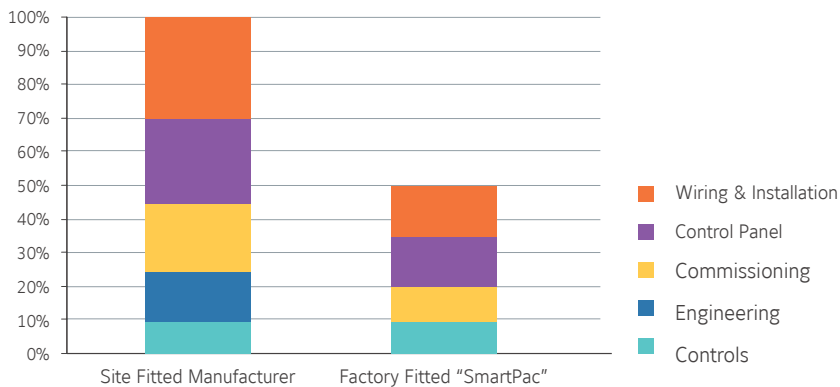

SmartPac and YORK® Air Handling units

The Air Handling Unit arrives on site **ready to connect** to the site network, and final commissioning is simplified through the unit's keypad and display.

Panel Power wiring, controls wiring, Variable Speed Drive, pre-engineered controller and required peripheral devices are all supplied, factory fitted and tested.



SmartPac and YORK® Fan Coil units

YORK® Fan Coil Units are available with factory packaged controls and numerous options for controllers and valves **to allow reduced installation time on site.**

A range of standard configurable or fully programmable controllers are offered along with a choice of Industry standard protocols. Valve requirements can also be met with a wide range of modulating and on/off actuators and isolation valves available and factory fitted.



SmartPac and YORK® Roof Top & Close Control units

Factory packaged controls' solution enable, to **dramatically reduce on-site commissioning costs.** Both are delivered to site with pre-installed controls, factory tested and ready to apply the power.

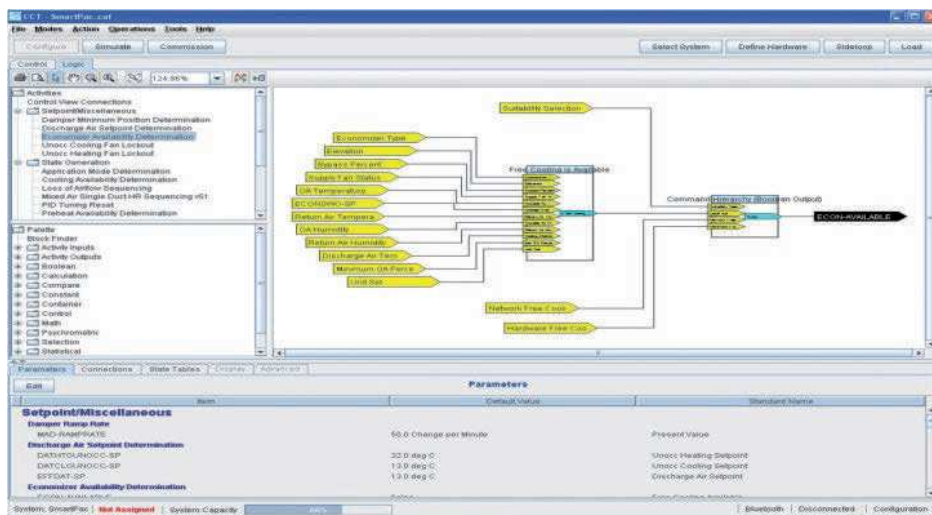

SmartPac and YORK® Standard Control panel

Furthermore, Variable Speed Drives give **extra efficiency communicating** with the Johnson controller using industry standard protocols and providing for seamless communications with existing BAS control systems.

Manufacturer reserves the rights to change specifications without prior notice.



Packaged Equipment & Large Split Systems

ROOMTOP

ROOFTOP

LARGE SPLIT

Control System

YKN2open

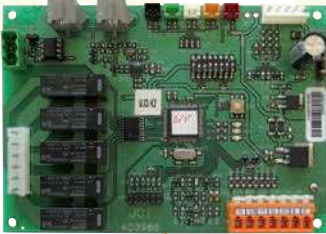

The YKN2open is a controller regulating all components and accessories. It will pro actively manage cool and heat stages to maintain a stable room temperature maximizing the efficiency.

Additionally, the benefits are:

- Redundancy on cool and heat stages (if one step is locked out, the PCB starts another one automatically).
- Random start between units to minimise electrical tariff.
- All stages will start in sequence to reduce peak inrush.
- Reduces nuisance calls by using 3 times "you are out" on all safeties before a hard lockout occurs.
- Automatic restart after power failure. Compressors run time priority.
- Alarm output relay and led diagnostic code. No parameters to check before starting.
- Lockout and incident level of protection. Last 10 lockouts stored in a non-volatile memory.
- 4 heating stages on hot water heating.
- **BMS connection (N2 Open protocol).**

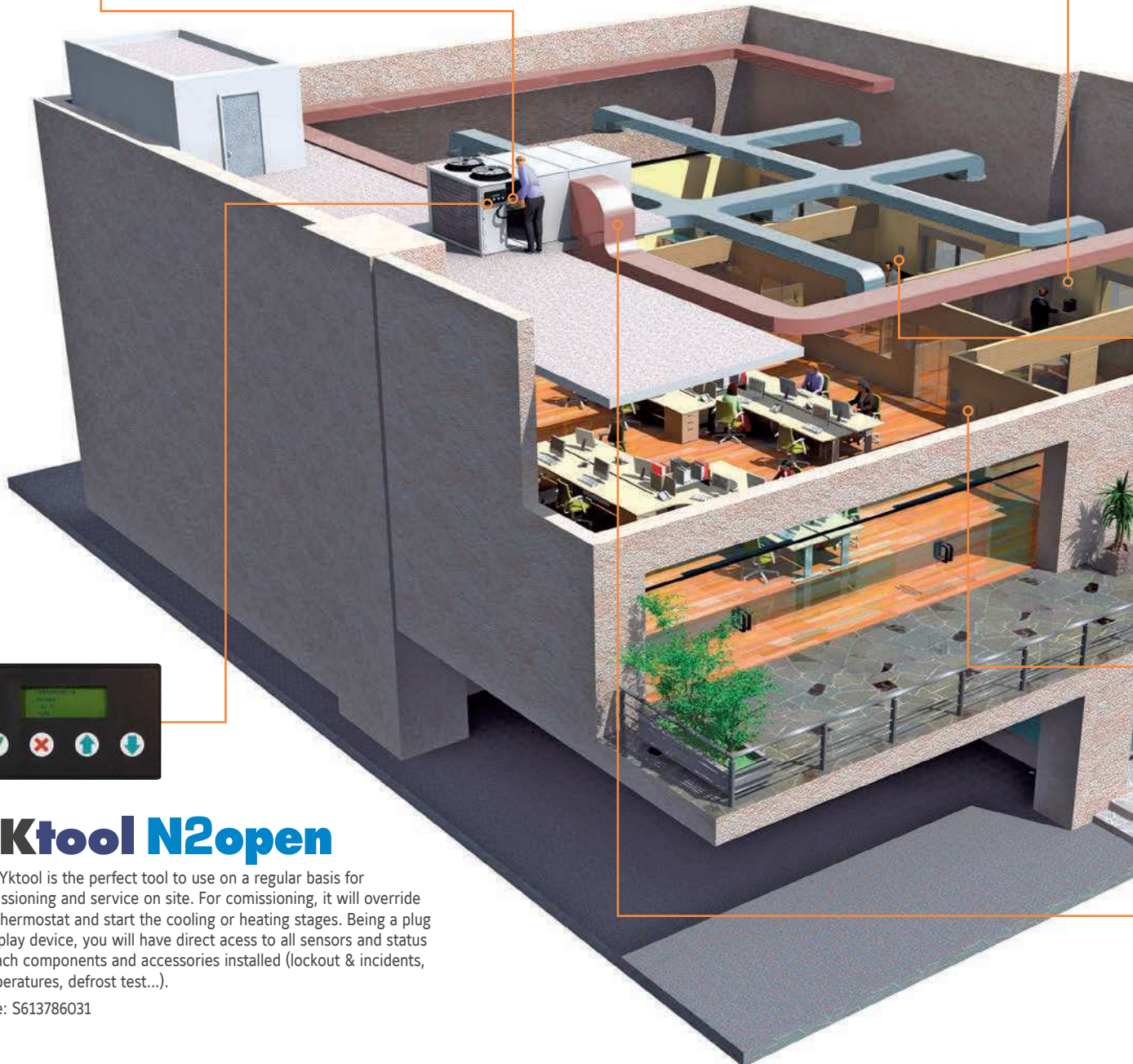

YKtool N2open

The Yktool is the perfect tool to use on a regular basis for comissioning and service on site. For comissioning, it will override the thermostat and start the cooling or heating stages. Being a plug and play device, you will have direct access to all sensors and status of each components and accessories installed (lockout & incidents, temperatures, defrost test...).

Code: S613786031



Thermostat DPC-1

- Day (normal), night (economy) and unoccupied (stand by).
- Lockout code on screen gives direct diagnostics.
- ON/OFF or programmable from dip switch setting.
- Day or night programmable state avoids wide internal temperature variation.
- 3 preset and 3 programmable profiles.
- Temperature override.
- Select the control sensor you want to use (integrated in the thermostat, return air in duct or room sensor).
- Turbo, normal or economy logic from dip switch setting.
- From -3°C to +3°C sensor offset.
- Average temperature with room or duct sensors.

Thermostats with integrated sensors

Thermostat models		DPC-1	DPC-1R
	Code	S603786044	S603786045
Roomtop	RTC and RTH	X	0
Rooftop	All models	0	0
Split system	VAC and VAH	X	0
	VCH	X	0

Main features			
Strategy	Turbo, normal or economy		
Auto restart after power failure	●		●
Number of cool stages	2	1	2
Number of heat stages	2	1	2
Auxiliary Heat	●		●
Automatic Heat/Cool change over	●		●
Continuous or auto indoor fan	●		●
Manual setback (Day/Night key)	Day, night and unoccupied		
Override possibility	●		●
Compressor anti short cycle	●		●
°C Range cooling / heating	10 to 32°C / 9 to 32°C		
Programmable, 7-day	●		●
Lockout codes	●		●
Outdoor air temperature	●		with YKN2Open
Sensor selection	●		●

X : Delivered as standard with the unit.
 O : Optional. ● : Function available.



RS-1

Room sensor

Indoor remote probe to provide close control of the ambient temperature at a location away from the DPC-1 and DPC-1R thermostats.

Code: S603786042



AS-1

Ambiance sensor

Digital remote probe to provide close control of the ambient temperature at a location away from DPC-1 and DPC-1R thermostats. Up to 4 remote probes can be connected to make an average of the room conditioned.

Code: S603786049



DS-1

Duct sensor

Remote probe to provide close control of the return air temperature in the duct, at a location away from DPC-1 and DPC-1R thermostats. The use of this probe is recommended when an indoor remote probe cannot be installed in the area where temperature is to be controlled.

Code: S603786047

BMS Connection



IP Network



METASYS
COMPATIBLE



DPC-1



DPC-1



YKN2open

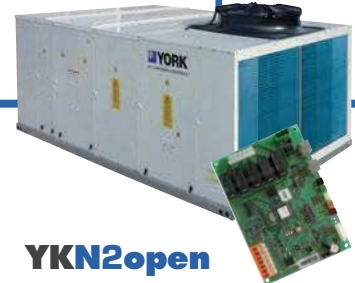

YKN2open



*Light control,
Power station...*

AHU



VRF



CHILLER



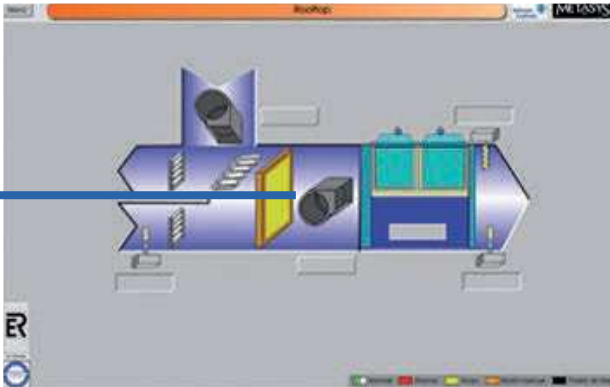

Sample screen

- BMS communication through new board YKN2Open delivered as standard (N2Open protocol)
- Possibility to fully control the unit and monitor more than 160 variables per unit.
- Can be integrated with other systems like lighting, fire&security or other HVAC equipment.
- Fully tailored solutions available (ask JCI sales office)

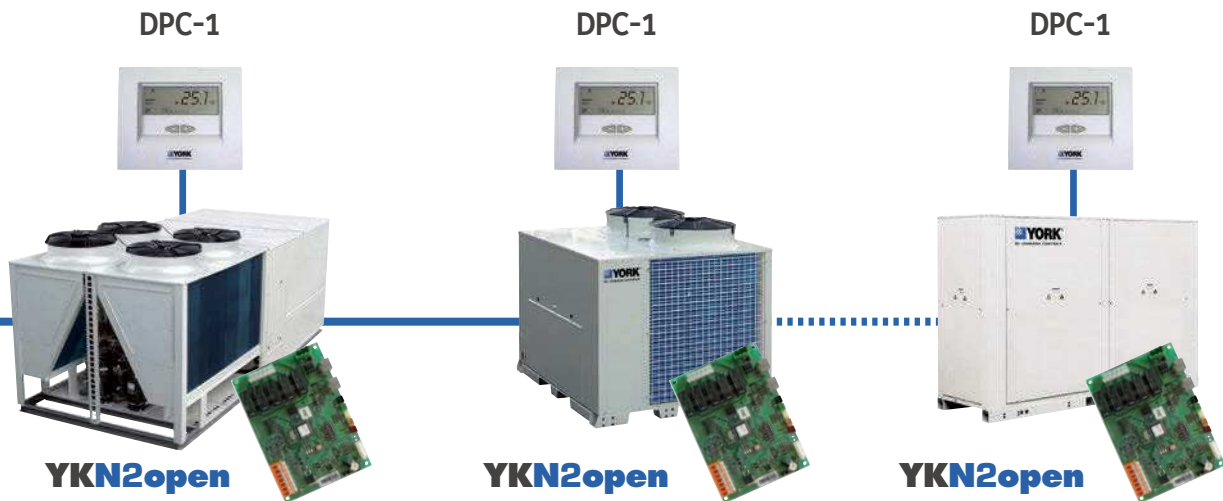

ACCESS CONTROL



FAN COILS



Roomtop

RTC-RTH - L

A complete range from 14.6 kW up to 27.0 kW



YKN2open

Features

- New YKN2open board
- Possibility to be installed outdoor
- Scroll Compressors
- High COP and EER
- 1/4 turn on electrical panel
- Expansion valves for models 20, 25 and 30
- High external static pressure on evaporator and condenser
- Digital thermostat DPC-1 and indoor air filter included

RTC 15 L

Nomenclature

L = version

Capacity range:
15 = 15 kW

Product category:
RTC = Cooling only
RTH = Heat pump

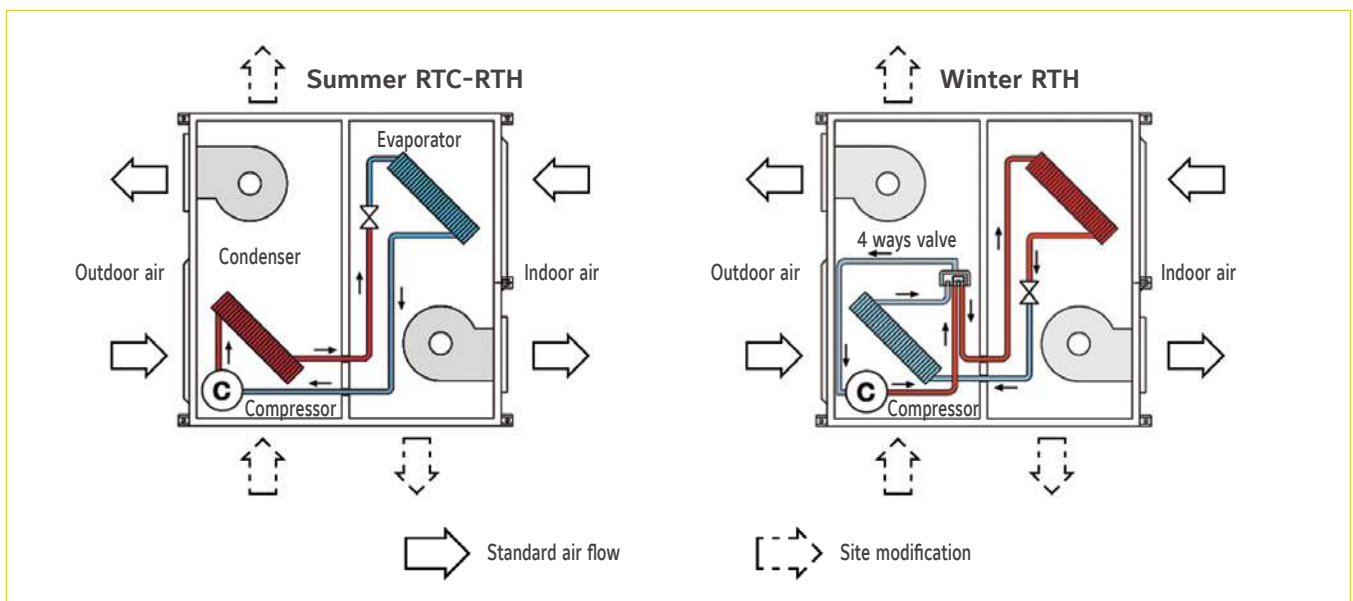

Roomtop

RTC-RTH 15 to 30 - L



Technical features

Cooling only models		RTC 15 L	RTC 20 L	RTC 25 L	RTC 30 L	
Cooling capacities	kW	14.60	19.90	22.20	27.00	
Power input in cooling	kW	5.50	8.60	10.00	12.00	
In duct outdoor side sound power level	dB(A)	72	74	77	81	
In duct indoor side sound power level	dB(A)	71	73	75	75	
Heat pump models		RTH 15 L	RTH 20 L	RTH 25 L	RTH 30 L	
Cooling capacities	kW	14.10	19.90	22.20	26.80	
Power input in cooling	kW	5.40	8.32	10.04	11.63	
Heating capacities	kW	13.80	17.80	20.80	25.40	
Power input in heating	kW	4.84	7.15	7.89	9.67	
In duct outdoor side sound power level	dB(A)	74	74	81	81	
In duct indoor side sound power level	dB(A)	73	73	81	81	
Common characteristics						
Power supply		400V/3 + N/ 50Hz				
Nominal current RTC / RTH	A	11.6 / 11.5	19 / 19	21 / 21	23 / 23	
Starting current	A	64	95	111	118	
Main switch (1)	A	20	25	25	32	
Main cable (1)	Nbr.xmm ²	5 x 4	5 x 4	5 x 4	5 x 6	
Cable to standard thermostat (2)	Nbr.xmm ²	10 x 0.22				
Evaporator fan at nominal airflow	Airflow	m ³ /h	3 580	4 100	5 060	5 300
	Standard ESP	Pa	50	50	62	62
Condenser fan at nominal airflow	Airflow	m ³ /h	3 890	4 810	5 640	7 450
	Standard ESP	Pa	50	50	50	50
Nett dimensions	Height	mm	557	585	650	650
	Length	mm	1 312	1 575	1 750	1 770
	Depth	mm	1 312	1 575	1 656	2 056
Nett weight	RTC	kg	235	305	358	420
Nett weight	RTH	kg	243	317	379	434

(1) For information only. These should be checked for compliance with local regulations depending also on installation and cable type

(2) Shield type cable only

All the data are at EUROVENT conditions with 400V/3+N/50Hz.

Cooling : Entering indoor coil temp. 27°C / 19°C WB and outdoor temperature 35°C

Heating : Entering indoor coil temp. 20°C and outdoor temperature 7°C / 6°C WB

Compatibility table / Codes

Cooling only models		RTC 15 L	RTC 20 L	RTC 25 L	RTC 30 L	
		S661211545	S661212081	S661212545	S661213045	
Heat pump models		RTH 15 L	RTH 20 L	RTH 25 L	RTH 30 L	
		S662051544	S662052054	S662052545	S662053045	
Thermostat						
Delivered as standard with the unit		DPC-1				
YNK2Open Gateway BACnet / IP - JCI Metasys N2 **	S606791244	A	A	A	A	
YNK2Open Gateway Modbus TCP / IP - JCI Metasys N2 **	S606791245	A	A	A	A	
Accessories or options	Remarks	Code	RTC 15 L	RTC 20 L	RTC 25 L	RTC 30 L
			RTH 15 L	RTH 20 L	RTH 25 L	RTH 30 L
Electrical Heaters * (in duct)	5 kW / 3ph.	S611765653	A	A	A	A
	10 kW / 3ph.	S611765583	A	A	A	A
	15 kW / 3ph.	S611765513	A	A	A	A
Low ambient regulation	S613113087 *	O (1)	O	O	O	
Alarm relay board	S606791243	O/A	O/A	O/A	O/A	
Copper-copper coils unit	Contact us	O	O	O	O	

A= Accessory (supplied loose). O= Option (factory fitted). O/A=If you want this item factory fitted, precise it in the order form.

* Not protected against external conditions. ** To be released in 2016 - Ask JCI for availability

(1) Special reference - please ask JCI



Manufacturer reserves the rights to change specifications without prior notice.

ACTIVA Rooftop

ARC-ARG-ARH-ARD

A complete range from 17 kW up to 40 kW



YKN2open

Features

- High efficiency EER and COP
- Low noise level
- EC supply fan
- All configurations: Cooling only, Cooling + gas, Heating, Heating + Gas
- BMS connection as standard (N2Open protocol)
- Compact design
- Energy recovery (enthalpy wheel)
- External HP & LP access
- Filters G4, F6 & F7 available

A R C 032 A B Nomenclature

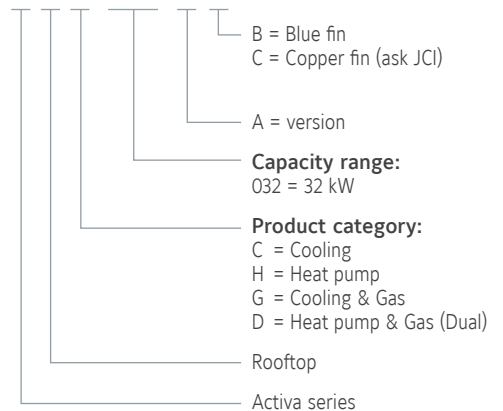



ACTIVA Rooftop

ARC-ARG-ARH-ARD 017 to 040 AB

Technical features

Cooling only models		ARC 017 AB	ARC 022 AB	ARC 032 AB	ARC 040 AB	
Net cooling capacities	kW	18.2	23.2	31	39.9	
Power input	kW	5.5	7.4	9.9	14.2	
EER		3.42	3.31	3.23	2.9	
Working range (full load / partial load)	°C	7°C ~ 46°C / -10°C ~ 52°C				
Heat pump models		ARH 017 AB	ARH 022 AB	ARH 032 AB	ARH 040 AB	
Net cooling capacities	kW	18.2	22.2	31	39.9	
Power input in cooling	kW	5.5	7.4	9.9	14.2	
EER		3.42	3.15	3.23	2.9	
Heating capacities (1)	kW	16.5	22.1	30.9	39.0	
Power input in heating	kW	5.4	6.9	9.8	13.5	
COP		3.2	3.36	3.23	3.0	
Working range (full load / partial load)	°C	-10°C ~ 46°C / -10°C ~ 52°C				
Cooling only + Gas heating models		ARG 017 AB	ARG 022 AB	ARG 032 AB	ARG 040 AB	
Net cooling capacities	kW	18.2	23.2	31	39.9	
Cooling power input	kW	5.5	7.4	9.9	14.2	
Standard Heating capacities (1) NET	kW	23	23	41	41	
Natural gas 2ND-H, G20	m³/h	2.5	2.5	4.5	4.5	
Working range (full load / partial load)	°C	-15°C ~ 46°C / -15°C ~ 52°C				
Heat pump + Gas heating models		ARD 017 AB	ARD 022 AB	ARD 032 AB	ARD 040 AB	
Net cooling capacities	kW	18.2	22.2	31	39.9	
Power input in cooling	kW	5.5	7.4	9.9	14.2	
Heating capacities (1)	kW	18.1	22.1	30.9	39.0	
Power input in heating	kW	5.7	6.9	9.8	13.5	
Standard Heating capacities (1) NET	kW	23	23	41	41	
Natural gas 2ND-H, G20	m³/h	2.5	2.5	4.5	4.5	
Working range (full load / partial load)	°C	-15°C ~ 46°C / -15°C ~ 52°C				
Common characteristics						
Power supply	400V/3 + N/ 50Hz					
Main switch	A	20	25	40	50	
Main cable	Nbr. x mm²	5 x 4	5 x 6	5 x 10	5 x 16	
Cable to thermostat	Nbr. x mm²	10 x 0.22				
Number of circuits / Compressor type	1 / 1 x Scroll		1 (Tandem) / 2 x Scroll			
Evaporator fan	Airflow	m³/h	3400	4300	5700	7400
	ASP	Pa	600	600	600	600
Nett dimensions	Height	mm	1 420	1 420	1 420	1 420
	Length	mm	1 866	1 866	2 135	2 135
	Depth	mm	1 540	1 540	1 850	1 850
Nett weight	ARC / ARG	kg	420 / 462	440 / 482	581 / 642	585 / 646
Nett weight	ARH / ARD	kg	425 / 467	445 / 487	587 / 648	591 / 652

All the data are at EUROVENT conditions with 400V/3+N/50Hz.

Cooling : Entering indoor coil temp. 27°C / 19°C WB and outdoor temperature 35°C - Heating : Entering indoor coil temp. 20°C and outdoor temperature 7°C / 6°C WB

(1) Add indoor fan motor consumption to know total heating capacity.

Codes

Cooling only models	ARC 017 AB	ARC 022 AB	ARC 032 AB	ARC 040 AB
	S661752110	S661752120	S661752130	S661752150
Heat pump models	ARH 017 AB	ARH 022 AB	ARH 032 AB	ARH 040 AB
	S661752113	S661752123	S661752133	S661752153
Cooling only + Gas heating models	ARG 017 AB	ARG 022 AB	ARG 032 AB	ARG 040 AB
	S661752111	S661752121	S661752131	S661752151
Heat pump + Gas heating models	ARD 017 AB	ARD 022 AB	ARD 032 AB	ARD 040 AB
	S661752112	S661752122	S661752132	S661752152
Thermostat				
to be ordered separately	DPC-1			



Manufacturer reserves the rights to change specifications without prior notice.

Activa rooftop details & features



High Efficiency

High efficiency compressor and fans managed by a smart control allows the unit to achieve and maintain the level of comfort required in the most efficient way, reducing therefore the energy bill.



Low Noise

Ultra quiet fans and optimized airflow reduces the noise level increasing the comfort. Compressors are mounted on shock absorbers and anti-vibration springs are available to avoid vibration transmissions into de building.



Easy Installation and Maintenance

The high level of usability of the control, the internal solutions adopted (like direct driven fans with variable speed) and the easy access to components simplify and reduce the need of external interventions. Full information on commissioning and maintenance plan are provided to help to ensure unit keeps running always in optimal conditions.



Compact Design

The refrigerant circuit layout has been redesigned and high efficiency exchangers been used to reduce the footprint and improve the transport and handling. Transition roofcurbs are available to fit in existing installations.

Accessories & options

	Code	Cooling only				Heat pump				Cooling + gas heating				Heat pump + gas heating				
		017	022	032	040	017	022	032	040	017	022	032	040	017	022	032	040	
Thermostat DPC-1	S603786044	A	A	A	A	A	A	A	A	A	A	A	A	A	A	A	A	
YNK2Open Gateway BACnet / IP - JCI Metasys N2 *	S606791244	A	A	A	A	A	A	A	A	A	A	A	A	A	A	A	A	
YNK2Open Gateway Modbus TCP / IP - JCI Metasys N2 *	S606791245	A	A	A	A	A	A	A	A	A	A	A	A	A	A	A	A	
Dry bulb triple input economizer or motorized air damper with rain hood	S611752301	O	O			O	O			O	O			O	O			
	S611752311			O	O			O	O			O	O			O	O	
Enthalpy probes	S613990081	O	O	O	O	O	O	O	O	O	O	O	O	O	O	O	O	
Indoor air quality sensor	S606819964	O/A	O/A	O/A	O/A	O/A	O/A	O/A	O/A	O/A	O/A	O/A	O/A	O/A	O/A	O/A	O/A	
Power Exhaust	S611752302	A	A			A	A			A	A			A	A			
	S611752312			A	A			A	A			A	A			A	A	
Barometric relief damper and rain hood	S611752472	A	A			A	A			A	A			A	A			
	S611752473			A	A			A	A			A	A			A	A	
Fresh air damper and rain hood (2)	S611752303	A	A			A	A			A	A			A	A			
	S611752313			A	A			A	A			A	A			A	A	
Low ambient kit	S611752381	O	O	O	O	O	O	O	O	O	O	O	O	O	O	O	O	
Roofcurb adapter (3)	S611752886	A	A			A	A			A	A			A	A			
	S611752887			A	A			A	A			A	A			A	A	
Fixed roof curb	S611752881	A	A			A	A			A	A			A	A			
	S611752882			A	A			A	A			A	A			A	A	
Adjustable roof curb	S611752883	A	A			A	A			A	A			A	A			
	S611752884			A	A			A	A			A	A			A	A	
Dirty filter switch	S613990085	O	O	O	O	O	O	O	O	O	O	O	O	O	O	O	O	
Smoke detector	S613995382	O	O	O	O	O	O	O	O	O	O	O	O	O	O	O	O	
Fire detection thermostat	S613903003	O	O	O	O	O	O	O	O	O	O	O	O	O	O	O	O	
Hot water coil	S611752351	O	O			O	O											
	S611752352			O	O			O	O									
Electric heaters	16 kW	S611752516	O	O			O	O										
	16 kW	S611752616			O	O			O	O								
	25 kW	S611752525	O	O			O	O										
	25 kW	S611752625			O	O			O	O								
	37 kW	S611752537			O	O			O	O								
Propane conversion Kit	S611752780									A	A	A	A	A	A	A	A	
Filter kit F6	S611752401	O	O			O	O			O	O			O	O			
	S611752402			O	O			O	O			O	O			O	O	
Filter kit F7	S611752411	O	O			O	O			O	O			O	O			
	S611752412			O	O			O	O			O	O			O	O	
Grill condenser coil protection	S611752451	O	O			O	O			O	O			O	O			
	S611752452			O	O			O	O			O	O			O	O	
Antivibration mounting kit	S611752461	A	A	A	A	A	A	A	A	A	A	A	A	A	A	A	A	
Energy recovery	S611752501	A	A			A	A			A	A			A	A			
	S611752511			A	A			A	A			A	A			A	A	
Filter kit F6 for energy recovery	S611755506	O	O			O	O			O	O			O	O			
	S611755516			O	O			O	O			O	O			O	O	
Filter kit F7 for energy recovery	S611752507	O	O			O	O			O	O			O	O			
	S611752517			O	O			O	O			O	O			O	O	
Alarm relay board	S606791243	O/A	O/A	O/A	O/A	O/A	O/A	O/A	O/A	O/A	O/A	O/A	O/A	O/A	O/A	O/A	O/A	
Copper-copper coil	Contact us	O	O	O	O	O	O	O	O	O	O	O	O	O	O	O	O	

O=Option (factory fitted). A=Accessory (supplied loose). O/A=If you want this item factory fitted, precise it in the order form.
 (1) Energy recovery accessory includes: economizer, rain hood, indoor air quality sensor and G4 filters.
 (2) Fresh air damper can not be installed if economizer or motorized damper is fitted.
 (3) Transition roofcurbs to fit in D_IC/D_IG/B_IG existing installations (090-150 kbtu/h).
 * To be released in 2016 - Ask JCI for availability

ACTIVA Rooftop

ARC-ARG-ARH-ARD

A complete range from 45.1 kW up to 84 kW



YKN2open

Features

- High efficiency EER and COP
- Low noise level
- All configurations: Cooling only, Cooling + gas, Heating, Heating + Gas
- BMS communication as standard (N2Open protocol)
- Energy recovery (enthalpy wheel)
- EC Return fan
- External HP & LP access
- Filters G4, F6 & F7 available
- Tandem configuration (up to 52°C outdoor temperature)

A R C 045 A B Nomenclature

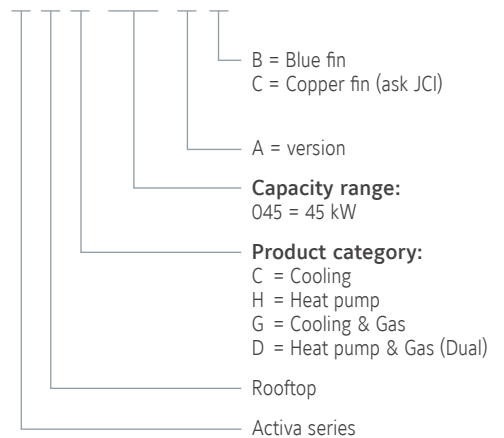



ACTIVA Rooftop

ARC-ARG-ARH-ARD 045 to 090 AB

Technical features

Cooling only models		ARC 045 AB	ARC 060 AB	ARC 075 AB	ARC 090 AB	
Net cooling capacities	kW	45.1	61.0	71.5	84.0	
Power input	kW	16.0	23.0	30.0	36.0	
EER		2.96	2.91	2.67	2.60	
Working range (full load / partial load) *	°C	7°C ~ 46°C / -10°C ~ 52°C				
Heat pump models		ARH 045 AB	ARH 060 AB	ARH 075 AB	ARH 090 AB	
Net cooling capacities	kW	47.6	61.9	71.4	83.4	
Power input in cooling	kW	17.0	20.0	28.0	36.0	
EER		3.00	3.06	2.67	2.60	
Heating capacities (1)	kW	45.2	58.0	71.7	86.5	
Power input in heating	kW	16.0	19.0	27.0	33.0	
COP		2.80	2.96	2.81	2.60	
Working range (full load / partial load) *	°C	-10°C ~ 46°C / -10°C ~ 52°C				
Cooling only + Gas heating models		ARG 045 AB	ARG 060 AB	ARG 075 AB	ARG 090 AB	
Net cooling capacities	kW	45.1	61.0	71.5	84.0	
Cooling power input	kW	16.0	23.0	30.0	36.0	
Standard Heating capacities (1)	kW	76.0	76.0	76.0	76.0	
Natural gas 2ND-H, G20	m³/h	8.60	8.60	8.60	8.60	
High Heating capacities (1)	kW	90.0	90.0	90.0	90.0	
Natural gas 2ND-H, G20	m³/h	9.80	9.80	9.80	9.80	
Working range (full load / partial load) **	°C	-15°C ~ 46°C / -15°C ~ 52°C				
Heat pump + Gas heating models		ARD 045 AB	ARD 060 AB	ARD 075 AB	ARD 090 AB	
Net cooling capacities	kW	47.6	61.9	71.4	83.4	
Cooling power input	kW	17.0	20.0	28.0	36.0	
Heating capacities (1)	kW	45.2	58.0	71.7	86.5	
Power input in heating	kW	16.0	19.0	27.0	33.0	
Standard Heating capacities (1)	kW	76.0	76.0	76.0	76.0	
Natural gas 2ND-H, G20	m³/h	8.60	8.60	8.60	8.60	
High Heating capacities (1)	kW	90.0	90.0	90.0	90.0	
Natural gas 2ND-H, G20	m³/h	9.80	9.80	9.80	9.80	
Working range (full load / partial load) **	°C	-15°C ~ 46°C / -15°C ~ 52°C				
Common characteristics						
Power supply	400V/3 + N/ 50Hz					
Main switch	A	50	63	80	80	
Main cable	Nbr. x mm²	5 x 10	5 x 16	5 x 25	5 x 25	
Cable to thermostat	Nbr. x mm²	10 x 0,22				
Number of circuits / Compressor type	1 (tandem) / 2 x scroll					
Evaporator fan at nominal airflow	Airflow	m³/h	8 500	11 500	13 500	16 000
	Power input	kW	3	4	5,5	7,5
Nett dimensions	Height	mm	1 316	1 316	1 367	1 367
	Length	mm	3 180	3 180	3 495	3 495
	Depth	mm	2 337	2 337	2 337	2 337
Nett weight ARC / ARG	kg	900 / 1 010	945 / 1 055	1 118 / 1 228	1 142 / 1 252	
Nett weight ARH / ARD	kg	930 / 1 040	985 / 1 095	1 145 / 1 255	1 220 / 1 330	

All the data are at EUROVENT conditions with 400V/3+N/50Hz.

Cooling : Entering indoor coil temp. 27°C / 19°C WB and outdoor temperature 35°C - Heating : Entering indoor coil temp. 20°C and outdoor temperature 7°C / 6°C WB

(1) Add indoor fan motor consumption to know total heating capacity.

* With Premium kit (full load / partial load): -10°C ~ 50°C / -10°C ~ 52°C

** With Premium kit (full load / partial load): -20°C ~ 50°C / -20°C ~ 52°C

Codes

Cooling only models	ARC 045 AB	ARC 060 AB	ARC 075 AB	ARC 090 AB
	S661752140	S661752160	S661752170	S661752190
Heat pump models	ARH 045 AB	ARH 060 AB	ARH 075 AB	ARH 090 AB
	S661752143	S661752163	S661752173	S661752193
Cooling only + Gas heating models	ARG 045 AB	ARG 060 AB	ARG 075 AB	ARG 090 AB
	S661752141	S661752161	S661752171	S661752191
Heat pump + Gas heating models	ARD 045 AB	ARD 060 AB	ARD 075 AB	ARD 090 AB
	S661752142	S661752162	S661752172	S661752192
Thermostat	DPC-1			
to be ordered separately				



Manufacturer reserves the rights to change specifications without prior notice.

Activa rooftop details & features



Condenser fan

New condenser fans with high technology blades and outdoor bell that reduce the turbulences in the air and therefore increase the efficiency and improve the noise level performance.



Tandem scroll compressors

Tandem compressors configuration allows the unit to operate at partial load (only with one compressor) with higher efficiency and increases the working range up to +52°C ambient temperature.

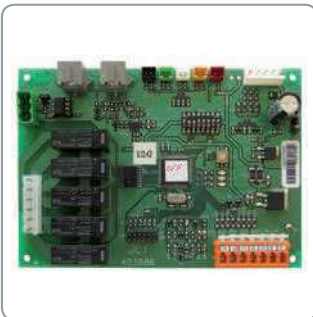

PCB board

The YKN2Open board keeps same features and benefits as YKlon V3 and adds new logical to control the tandem circuit, the new options (heat recovery, return fan) and the possibility to communicate with BMS system as standard (only N2Open protocol).



Return fan

Located in a special roof curb underneath the rooftop, it works simultaneously with the indoor fan in order to balance the amount of air supplied to and removed from the space. It is the best suited for systems with high return path static pressures. Also, incorporates EC technology and a differential pressure gauge to easy set up and maintain automatically the working point in the installation.

Energy recovery system

It is the preferred solution to solve two conflicting requirements: reduce running costs (increase efficiency) while maintaining the indoor air quality at high levels (through ventilation).
 An enthalpy rotary wheel retains the energy from the exhaust air and transmits it to the fresh air stream that is being supplied in the conditioned space.
 The material used is manufactured with the latest technology to increase the energy transmission in both sensible and latent heat.
 The wheel is split into 6 portions that can be easily removed for cleaning.

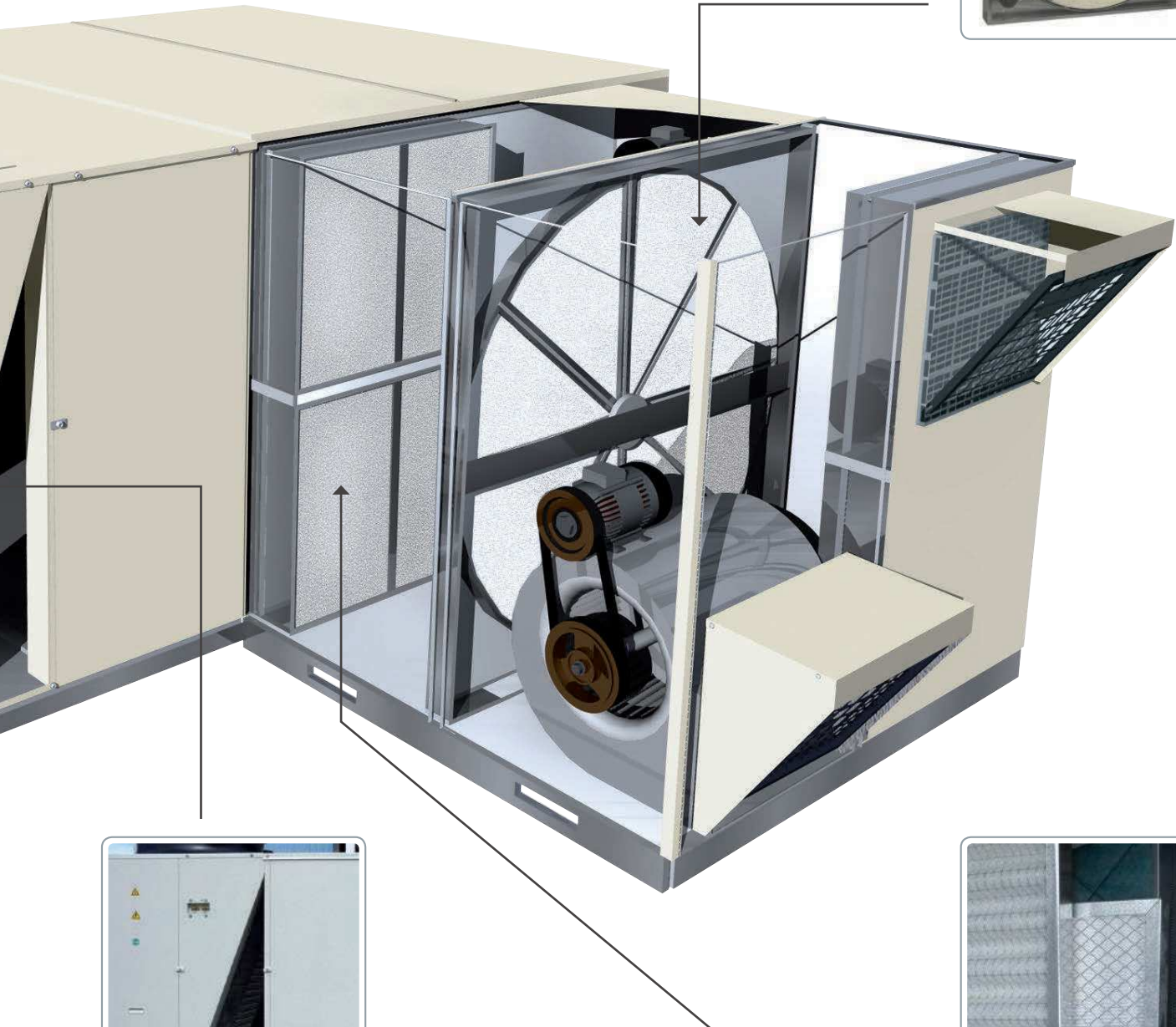

V-Coils

Made in blue fin (or in copper for harsh conditions under special request), increases the heat exchange surface for a given rooftop footprint. The floor pan is sloped for easy condensates drainage.

Filter options

Washable air filters: G4 class filter (gravimetric efficiency above 90%) and M1 fire class, it comes with galvanized sheet metal frame that allows easy cleaning and replacement. Delivered as standard.

Filter kit F6: for Average Opacimetric efficiency (em) $60\% \leq em \leq 80\%$
 Filter kit F7: for Average Opacimetric efficiency (em) $80\% \leq em \leq 90\%$

As per EN 779

Accessories & options

Accessories & options

	Code	Cooling only				Heat pump			
		45	60	75	90	45	60	75	90
Thermostat DPC-1	S603786044	A	A	A	A	A	A	A	A
YNK2Open Gateway BACnet / IP - JCI Metasys N2 **	S606791244	A	A	A	A	A	A	A	A
YNK2Open Gateway Modbus TCP / IP - JCI Metasys N2 **	S606791245	A	A	A	A	A	A	A	A
Dry bulb triple input economizer or motorized air damper with rain hood	S661752301	O	O			O	O		
	S661752311			O	O			O	O
Enthalpy probes	S613990081	O	O	O	O	O	O	O	O
Indoor air quality sensor	S606819964	A	A	A	A	A	A	A	A
Power Exhaust	S661752302	A	A			A	A		
	S661752322			A	A			A	A
Barometric relief damper and rain hood	S613990472	A	A			A	A		
	S613990473			A	A			A	A
Fresh air damper and rain hood (2)	S661752303	A	A			A	A		
	S661752323			A	A			A	A
High pressure drive	4 kW	S611990401	O			O			
	5.5 kW	S611990601		O			O		
	7.5 kW (IE3)	S611990701			O			O	
	11 kW (IE3)	S611990903				O			O
Soft start indoor fan	5.5 kW	S606744690	O	O	O	O	O	O	O
	11.5 kW	S606744691	O	O	O	O	O	O	O
Premium Kit (LAK included) *	S613118302	O				O			
	S613118303		O	O	O		O	O	O
Side duct flanges	S613991482	A	A			A	A		
	S613991483			A	A			A	A
Fixed roof curb	S613991884	A	A			A	A		
	S613991885			A	A			A	A
Adjustable roof curb	S613992081	A	A			A	A		
	S613992082			A	A			A	A
Dirty filter switch	S613990085	O	O	O	O	O	O	O	O
Smoke detector	S613995382	O	O	O	O	O	O	O	O
Fire detection thermostat	S613903003	O	O	O	O	O	O	O	O
Hot water coil	S611083351	O	O	O	O	O	O	O	O
	12 kW	S611761584	O	O	O	O	O	O	O
Electric heaters	25 kW	S611762284	O	O	O	O	O	O	O
	37 kW	S611763385	O	O	O	O	O	O	O
	50 kW	S611764485	O	O	O	O	O	O	O
Propane conversion Kit	S611801780	A	A	A	A	A	A	A	A
High heat gas conversion kit	S611803080	O	O	O	O	O	O	O	O
Filter kit F6	S611300401	O	O			O	O		
	S611300701			O				O	
	S611300901				O				O
Filter kit F7	S611300402	O	O			O	O		
	S611300702			O				O	
	S611300902				O				O
Grill condenser coil protection	S661752304	O				O			
	S661752324		O				O		
	S661752314			O	O			O	O
Antivibration mounting kit	S613990411	A	A	A	A	A	A	A	A
Return fan bottom duct	S613993042	A	A			A	A		
	S613993072			A	A			A	A
Energy recovery	Q6000 (1)	S611994511	A	A			A	A	
	Q3000 (1)	S611994512	A	A			A	A	
	Q9000 (1)	S611997511			A	A		A	A
	Q4500 (1)	S611997512			A	A		A	A
Filter kit F6 for energy recovery	S611994506	O	O			O	O		
	S611997506			O	O			O	O
Filter kit F7 for energy recovery	S611994507	O	O			O	O		
	S611997507			O	O			O	O
Alarm relay board	S606791243	O/A	O/A	O/A	O/A	O/A	O/A	O/A	O/A
Copper-copper coil	Contact us	O	O	O	O	O	O	O	O

O=Option (factory fitted). A=Accessory (supplied loose). O/A=If you want this item factory fitted, precise it in the order form.

(1) = Energy recovery accessory includes: economizer, rain hood, indoor air quality sensor and G4 filters.

(2) Fresh air damper can not be installed if economizer or motorized damper is fitted.

* Features: increased efficiency by 0.15, extended max outdoor temperature up to +50°C at full load, Low ambient kit.

** To be released in 2016 - Ask JCI for availability



Accessories & options

	Code	Cooling + gas heating				Heat pump + gas heating			
		45	60	75	90	45	60	75	90
Thermostat DPC-1	S603786044	A	A	A	A	A	A	A	A
YNK2Open Gateway BACnet / IP - JCI Metasys N2 **	S606791244	A	A	A	A	A	A	A	A
YNK2Open Gateway Modbus TCP / IP - JCI Metasys N2 **	S606791245	A	A	A	A	A	A	A	A
Dry bulb triple input economizer or motorized air damper with rain hood	S661752301	O	O			O	O		
	S661752311			O	O			O	O
Enthalpy probes	S613990081	O	O	O	O	O	O	O	O
Indoor air quality sensor	S606819964	A	A	A	A	A	A	A	A
Power Exhaust	S661752302	A	A			A	A		
	S661752322			A	A			A	A
Barometric relief damper and rain hood	S613990472	A	A			A	A		
	S613990473			A	A			A	A
Fresh air damper and rain hood (2)	S661752303	A	A			A	A		
	S661752323			A	A			A	A
High pressure drive	4 kW S611990401	O				O			
	5.5 kW S611990601		O				O		
	7.5 kW (IE3) S611990701			O				O	
	11 kW (IE3) S611990903				O				O
Soft start indoor fan	5.5 kW S606744690	O	O	O	O	O	O	O	O
	11.5 kW S606744691	O	O	O	O	O	O	O	O
Premium Kit (LAK included) *	S613118302	O				O			
	S613118303		O	O	O		O	O	O
Side duct flanges	S613991482	A	A			A	A		
	S613991483			A	A			A	A
Fixed roof curb	S613991884	A	A			A	A		
	S613991885			A	A			A	A
Adjustable roof curb	S613992081	A	A			A	A		
	S613992082			A	A			A	A
Dirty filter switch	S613990085	O	O	O	O	O	O	O	O
Smoke detector	S613995382	O	O	O	O	O	O	O	O
Fire detection thermostat	S613903003	O	O	O	O	O	O	O	O
Hot water coil	S611083351								
	12 kW S611761584								
	25 kW S611762284								
	37 kW S611763385								
	50 kW S611764485								
Propane conversion Kit	S611801780	A	A	A	A	A	A	A	A
High heat gas conversion kit	S611803080	O	O	O	O	O	O	O	O
Filter kit F6	S611300401	O	O			O	O		
	S611300701			O				O	
	S611300901				O				O
Filter kit F7	S611300402	O	O			O	O		
	S611300702			O				O	
	S611300902				O				O
Grill condenser coil protection	S661752304	O				O			
	S661752324		O				O		
	S661752314			O	O			O	O
Antivibration mounting kit	S613990411	A	A	A	A	A	A	A	A
Return fan bottom duct	S613993042	A	A			A	A		
	S613993072			A	A			A	A
Energy recovery	Q6000 (1) S611994511	A	A			A	A		
	Q3000 (1) S611994512	A	A			A	A		
	Q9000 (1) S611997511			A	A			A	A
	Q4500 (1) S611997512			A	A			A	A
Filter kit F6 for energy recovery	S611994506	O	O			O	O		
	S611997506			O	O			O	O
Filter kit F7 for energy recovery	S611994507	O	O			O	O		
	S611997507			O	O			O	O
Alarm relay board	S606791243	O/A	O/A	O/A	O/A	O/A	O/A	O/A	O/A
Copper-copper coil	Contact us	O	O	O	O	O	O	O	O

O=Option (factory fitted). A=Accessory (supplied loose). O/A=If you want this item factory fitted, precise it in the order form.

(1) = Energy recovery accessory includes: economizer, rain hood, indoor air quality sensor and G4 filters.

(2) Fresh air damper can not be installed if economizer or motorized damper is fitted

* Features: increased efficiency by 0.15, extended max outdoor temperature up to +50°C at full load, Low ambient kit.

** To be released in 2016 – Ask JCI for availability

Large ACTIVA Rooftop

ARC-ARG-ARH-ARD

A complete range from 105 kW up to 169 kW



YKN2open

Features

- High efficiency EER and COP
- Quiet operation
- All configurations: Cooling only, Cooling + gas, Heating, Heating + Gas
- BMS communication as standard (N2Open protocol)
- Partial loads
- Extended working range (up to 52°C outdoor temperature)
- F6 & F7 filters available as option (G4 standard)
- Energy recovery (ask JCI for availability)

A R C 150 A B Nomenclature

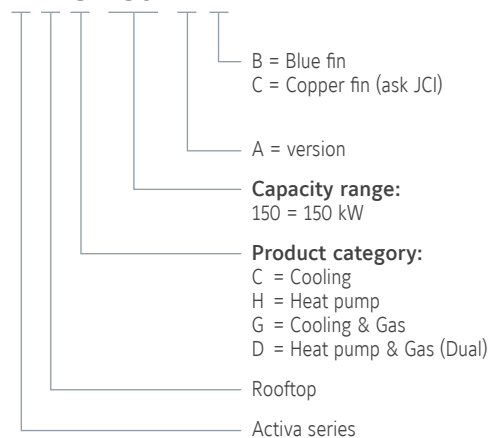



Large ACTIVA Rooftop

ARC-ARG-ARH-ARD 100 to 175 AB

Technical features

Cooling only models		ARC 100 AB	ARC 125 AB	ARC 150 AB	ARC 175 AB	
Net cooling capacities	kW	108.1	121.8	149.3	169.0	
Power input	kW	34	41	59	64	
EER		3.46	3.21	3.13	2.91	
Working range (full load / partial load) *	°C	7°C ~ 46°C / -10°C ~ 52°C				
Heat pump models		ARH 100 AB	ARH 125 AB	ARH 150 AB	ARH 175 AB	
Net cooling capacities	kW	108.1	121.8	149.3	169.0	
Power input in cooling	kW	34	41	59	64	
EER		3.46	3.21	3.13	2.91	
Heating capacities (1)	kW	104.6	118.4	147.0	167.0	
Power input in heating	kW	33	37	53	61	
COP		3.48	3.44	3.20	2.96	
Working range (full load / partial load) *	°C	-10°C ~ 46°C / -10°C ~ 52°C				
Cooling only + Gas heating models		ARG 100 AB	ARG 125 AB	ARG 150 AB	ARG 175 AB	
Net cooling capacities	kW	108.1	121.8	149.3	169.0	
Cooling power input	kW	34	41	59	64	
Standard Heating capacities (1)	kW	125.0	125.0	170.0	170.0	
Natural gas 2ND-H, G20	m³/h	14.1	14.1	19.1	19.1	
Working range (full load / partial load) **	°C	-15°C ~ 46°C / -15°C ~ 52°C				
Heat pump + Gas heating models		ARD 100 AB	ARD 125 AB	ARD 150 AB	ARD 175 AB	
Net cooling capacities	kW	108.1	121.8	149.3	169.0	
Cooling power input	kW	34	41	59	64	
Heating capacities (1)	kW	104.6	118.4	152.0	166.7	
Power input in heating	kW	33	37	53	61	
Standard Heating capacities (1)	kW	125.0	125.0	170.0	170.0	
Natural gas 2ND-H, G20	m³/h	14.1	14.1	19.1	19.1	
Working range (full load / partial load) **	°C	-15°C ~ 46°C / -15°C ~ 52°C				
Common characteristics						
Power supply	400V / 3 / 50Hz					
Main switch	A	100	125	160	200	
Main cable	Nbr. x mm²	3 x 35	3 x 50	3 x 50	3 x 70	
Cable to thermostat	Nbr. x mm²	10 x 0,22				
Number of circuits / Compressor type	2 (tandem) / 4 x scroll					
Evaporator fan at nominal airflow	Airflow	m³/h	19 000	21 000	27 000	31 000
	Power input	kW	3.0	3.3	8.3	9.1
Nett dimensions	Height	mm	2 142		2 142	
	Length	mm	4 036		5 085	
	Depth	mm	2 250		2 250	
Nett weight	ARC / ARG	kg	1 737 / 2 080	1 744 / 2 125	2 074 / 2 410	2 090 / 2 450
Nett weight	ARH / ARD	kg	1 765 / 2 125	1 772 / 2 170	2 135 / 2 460	2 150 / 2500

PRELIMINARY DATA

All the data are at EUROVENT conditions with 400V/3+N/50Hz.

Cooling : Entering indoor coil temp. 27°C / 19°C WB and outdoor temperature 35°C - Heating : Entering indoor coil temp. 20°C and outdoor temperature 7°C / 6°C WB

(1) Add indoor fan motor consumption to know total heating capacity.

* With Premium kit (full load / partial load): -10°C ~ 50°C / -10°C ~ 52°C

** With Premium kit (full load / partial load): -20°C ~ 50°C / -20°C ~ 52°C

Red color indicates preliminary data.

Codes

Cooling only models	ARC 100 AB	ARC 125 AB	ARC 150 AB	ARC 175 AB
	S661852400	S661852420	S661852450	S661852480
Heat pump models	ARH 100 AB	ARH 125 AB	ARH 150 AB	ARH 175 AB
	S661852403	S661852423	S661852453	S661852483
Cooling only + Gas heating models	ARG 100 AB	ARG 125 AB	ARG 150 AB	ARG 175 AB
	S661852401	S661852421	S661852451	S661852481
Heat pump + Gas heating models	ARD 100 AB	ARD 125 AB	ARD 150 AB	ARD 175 AB
	S661852402	S661852422	S661852452	S661852482
Thermostat	to be ordered separately			
	DPC-1			



Manufacturer reserves the rights to change specifications without prior notice.

Large Activa rooftop details

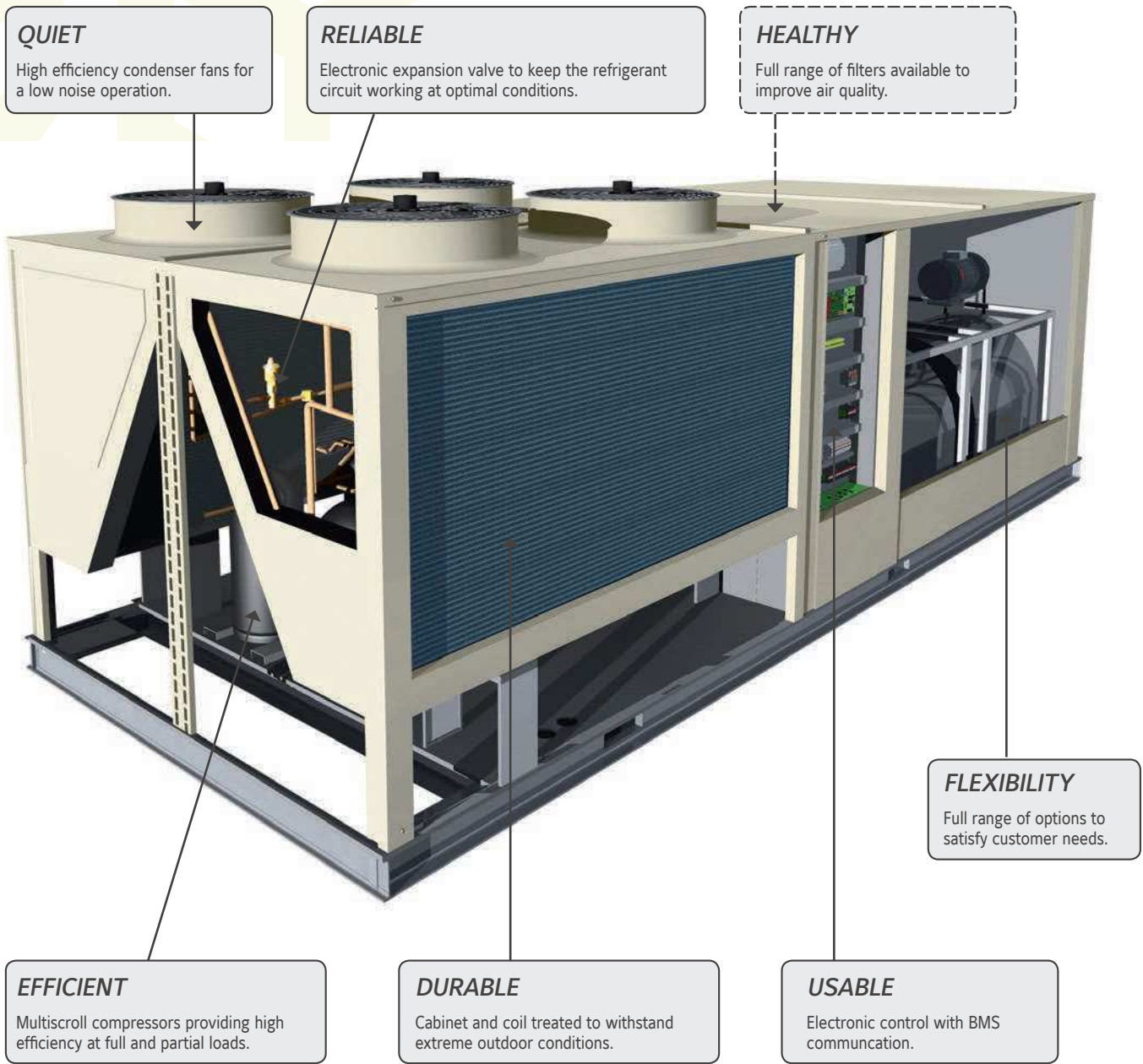

QUIET
High efficiency condenser fans for a low noise operation.

RELIABLE
Electronic expansion valve to keep the refrigerant circuit working at optimal conditions.

HEALTHY
Full range of filters available to improve air quality.

FLEXIBILITY
Full range of options to satisfy customer needs.

EFFICIENT
Multiscroll compressors providing high efficiency at full and partial loads.

DURABLE
Cabinet and coil treated to withstand extreme outdoor conditions.

USABLE
Electronic control with BMS communication.

NEW
ENERGY RECOVERY
By using the new Energy Recovery Modules for Large Activa Rooftops we will be able to reduce the running costs (increase efficiency) while maintaining the indoor air quality at high levels (through ventilation).
The enthalpy rotary wheel inside the cabinet will allow us to recover 71 to 75% of the sensible energy of the exhausted air and about 68% of the latent energy.
**To be released during 2016 – Ask JCI for availability*



Accessories & options

		Code	Cooling only				Heat pump				Cooling + gas heating				Heat pump + gas heating			
			100	125	150	175	100	125	150	175	100	125	150	175	100	125	150	175
Thermostat DPC-1		S603786044	A	A	A	A	A	A	A	A	A	A	A	A	A	A	A	A
YNK2Open Gateway BACnet / IP - JCI Metasys N2 **		S606791244	A	A	A	A	A	A	A	A	A	A	A	A	A	A	A	A
YNK2Open Gateway Modbus TCP / IP - JCI Metasys N2 **		S606791245	A	A	A	A	A	A	A	A	A	A	A	A	A	A	A	A
Dry bulb triple input economizer or motorized air damper with rain hood		S611751011	O	O			O	O			O	O			O	O		
		S611751511			O	O			O	O			O	O			O	O
Enthalpy probes		S613990081	O	O	O	O	O	O	O	O	O	O	O	O	O	O	O	O
Indoor air quality sensor		S606819964	O/A	O/A	O/A	O/A	O/A	O/A	O/A	O/A	O/A	O/A	O/A	O/A	O/A	O/A	O/A	O/A
Power Exhaust		S611751021	A	A			A	A			A	A			A	A		
		S611751521			A	A			A	A			A	A			A	A
Barometric relief damper		S611751031	A	A			A	A			A	A			A	A		
		S611751531			A	A			A	A			A	A			A	A
Fresh air damper		S613751021	A	A			A	A			A	A			A	A		
		S613751521			A	A			A	A			A	A			A	A
High pressure drive	7.5 kW (IE3)	S611751091	O	O			O	O			O	O			O	O		
	11 kW (IE3)	S611751093	O	O			O	O			O	O			O	O		
	5.5 kW (IE3)	S611751591			O				O				O				O	
	7.5 kW (IE3)	S611751592			O	O			O	O			O	O			O	O
Side duct supply		S611751061	O	O			O	O			O	O			O	O		
		S611751561			O	O			O	O			O	O			O	O
Soft start indoor fan	5.5 kW	S606744690	O	O	O	O	O	O	O	O	O	O	O	O	O	O	O	O
	11.5 kW	S606744691	O	O	O	O	O	O	O	O	O	O	O	O	O	O	O	O
Premium Kit (LAK included) *		S611751071	O	O	O	O	O	O	O	O	O	O	O	O	O	O	O	O
Fixed roof curb		S611751081	A	A			A	A			A	A			A	A		
		S611751581			A	A			A	A			A	A			A	A
Adjustable roof curb		S611751082	A	A			A	A			A	A			A	A		
		S611751582			A	A			A	A			A	A			A	A
Dirty filter switch		S613990085	O	O	O	O	O	O	O	O	O	O	O	O	O	O	O	O
Smoke detector		S613995382	O	O	O	O	O	O	O	O	O	O	O	O	O	O	O	O
Fire detection thermostat		S613903003	O	O	O	O	O	O	O	O	O	O	O	O	O	O	O	O
Hot water coil		S611751051	O	O			O	O										
		S611751551			O	O			O	O								
Electric heaters	37 kW	S611751037	O	O	O	O	O	O	O	O								
	50 kW	S611751050	O	O	O	O	O	O	O	O								
	60 kW	S611751060	O	O	O	O	O	O	O	O								
Filter kit F6		S611751046	O	O			O	O			O	O			O	O		
		S611751546			O	O			O	O			O	O			O	O
Filter kit F7		S611751047	O	O			O	O			O	O			O	O		
		S611751547			O	O			O	O			O	O			O	O
Grill condenser coil protection		S611751041	O	O			O	O			O	O			O	O		
		S611751541			O	O			O	O			O	O			O	O
Antivibration mounting kit 100/125		S613751011	O	O			O	O			O	O			O	O		
Antivibration mounting kit 150/175		S613751511			O	O			O	O			O	O			O	O
Energy recovery 100/125 Q10000 (1) **		S611751001	A	A			A	A			A	A			A	A		
Energy recovery 150/175 Q15000 (1) **		S611751501			A	A			A	A			A	A			A	A
Filter kit F6 heat recovery		Contact us	O	O			O	O			O	O			O	O		
		Contact us			O	O			O	O			O	O			O	O
Filter kit F7 heat recovery		Contact us	O	O			O	O			O	O			O	O		
		Contact us			O	O			O	O			O	O			O	O
Alarm relay board		S606791243	O/A	O/A	O/A	O/A	O/A	O/A	O/A	O/A	O/A	O/A	O/A	O/A	O/A	O/A	O/A	O/A
Copper-copper coil		Contact us	O	O	O	O	O	O	O	O	O	O	O	O	O	O	O	O

O=Option (factory fitted). A=Accessory (supplied loose). O/A=If you want this item factory fitted, precise it in the order form.

(1) = Energy recovery accessory includes: economizer, rain hood, indoor air quality sensor and G4 filters.

* Features: increased efficiency by 0.15, extended max outdoor temperature up to +50°C at full load, Low ambient kit.

** To be released in 2016 – Ask JCI for availability

Rooftop & Large Rooftop accessories & options



Triple input economizer

This system utilizes 3 probes: Return Air, Outdoor Air and Supply Air. The Outdoor Air damper and the Return Air dampers are mechanically interconnected in order to provide the same airflow at the coil inlet, with a single damper motor. The PCB compares sensor values and modulates the dampers providing maximum efficiency of the economiser system (free cooling) and comfort (Supply Air > 12°C). Combined with the air quality sensor, your payback will be ensured within few months. The rain hood is painted to match the basic unit and aluminium mesh pre-filter prevents water penetration.



Indoor air quality

This sensor measures concentrations of pollutant gases, such as tobacco smoke, human body odours, kitchen odours, carbon monoxide, etc... It automatically overrides the economizer when pollutant levels rise above preset limits. A shorting plug will set the algorithm to acceptable, good or very good air quality. This VOC sensor (Volatile Organic Compounds) sends an ON/OFF signal to the control PCB. The YKN2Open will then adjust the fresh air damper, optimising indoor air quality and minimising the energy consumption.

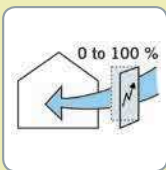

Motorised outdoor air damper

Equipped with the same dampers as the economizer, the Return Air probe is not used. Outdoor air damper opens to pre-set position whenever the indoor fan is operating (selected from the thermostat, the indoor fan can be activated with the compressor or to operate continuously) and will drive fully closed when the indoor fan shuts down. The rain hood is painted to match the basic unit and aluminium mesh pre-filter prevents water penetration.

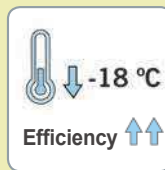

Premium Kit - Low ambient control

All our rooftops are designed to work in cooling mode down to 7°C ambient temperatures. Although this working range suits most applications, the units can operate correctly down to -18°C with optional Premium Kit. The Premium Kit option consists on an EC condensing fan that will allow us to increase the airflow at reduced consumption. Also we have condensing and evaporating pressure control that will extend our operating limits. It's estimated an increased efficiency by +0.15% in EER and COP.



Enthalpy sensors

To control the economizer in humid areas, or when indoor air humidity needs to remain dry, you should select enthalpy regulation. Enthalpy sensors will be used with the triple input economizer.



High pressure drive

The high pressure drive will increase the supply fan performance for applications requiring greater air flow and/or static pressure. Please consult technical guide for more information.

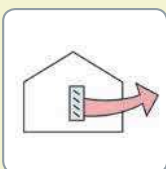

Barometric relief damper

This accessory can be used to relieve internal air pressure on units equipped with triple input economiser or motorised air damper but no power exhaust. When the rooftop is working in free cooling or introducing fresh air, the damper opens to relieve over pressure from the return air section. This accessory is comprised of a rain hood, a protective grille and a fully assembled damper.



Power Exhaust

Used to mechanically relieve internal air pressure from the Return Air section and ensure efficient fresh air introduction on units equipped with triple input economiser or motorised air damper. The power exhaust fan motor works when enough Outdoor Air is blowing into the room and if Outdoor Air temperature is acceptable (12°C < t° < 30°C).



Fresh air damper and rain hood

The most cost effective method with a complete rain hood and a fixed damper that can be adjusted to provide approximately 10, 15 or 25% of fresh air.



Smoke detector

The smoke detector is protecting the AHU but must not be used to ensure a full building protection against smoke danger. If smoke is detected the AHU is shutdown (lockout). A manual reset is necessary.



Fire detection thermostat

This fire detection thermostat is protecting the AHU but must not be used to ensure a full building protection against fire danger. The standard AHU is protected as standard with a Supply Air probe that shuts the unit down (lockout) when temperature exceeds 80°C. The electro-mechanical fire detection thermostat is used to fulfil specific local requirement. A manual reset is necessary.

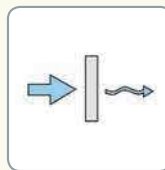

Dirty filter switch

Ensures that clean air is being supplied, advises when maintenance is required to prevent excessive depression and ensures water integrity of the AHU. These are the main advantages of filter dirty switch. Connected with the DPC-1 thermostat, the filter icon will appear on the thermostat screen when a filter change is required.

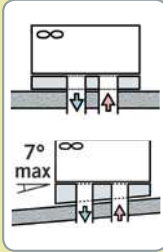

Fixed and adjustable roof curbs

Ideal for down-flow applications, it is a great help for installation allowing duct connections, electrical connection and weatherproofing between the roofcurb and the roof of the building. Shipped in kit form, it also gives sufficient height for condensate trap operation.

The adjustable roof curbs have the same benefits as the fixed roof curb, it allows the rooftop to be levelled on a roof with up to 7° slope (4%).

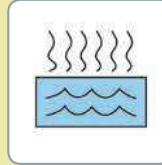

Hot water coil with control

The hot water coil and his control are always fitted, wired and factory tested. Located in the supply air section, side or bottom duct connection is possible without any modification. Complete with an anti-frost thermostat, the PCB will activate the modulated valve (24V supply, 0 – 10V modulating signal) in order to get the best comfort. A jumper will allow using hot water coil as 1st heating stage.

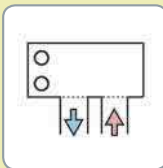

Side duct flanges

It's an optional (factory fitted) required when rooftops from sizes 45-175 need to work with horizontal air configuration. It's not required for models 17 to 40.

Composed of easy to install sheet metal panels to allow ductwork connections on the side of the AHU for horizontal return air and/or supply air

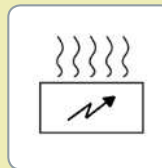

Electric heaters

Available on cooling only and Heat pump units, the electric heater is protected with two overheats per element.

When the overheat operates, there is a lock out of the faulty electric heater stage and the PCB starts automatically another heat stage.



Kit conversion propane

This kit comprises replacement burner, pilot injectors and all necessary instructions for converting the natural gas burner to propane gas. The nominal pressure of the propane gas should be 37 mbar.



High heat gas

This kit comprises replacement burner injectors and all necessary instructions to provide high heat capacity for gas rooftop.

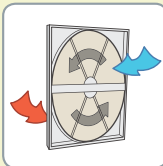

Energy recovery

Attached to the return air box of the rooftop, a rotary enthalpy wheel retrieves the energy of the exhausted air and transmits it to the fresh air intake. A special material used in the wheel allows that latent heat as well as sensible heat are transmitted.

Available during 2016 for models ARx-100-175. Consult JCI for availability

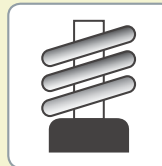

Antivibration mounting kit

It is composed by a set of stainless steel springs, to be assembled underneath the rooftop in a specific position. Their installation avoids the potential vibration transmission of the equipment to the building and reduces therefore the noise level (compressors have their own shock absorbers delivered as standard).

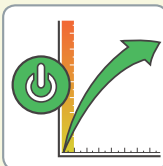

Indoor fan soft start

Compact control unit with a motor with AC semiconductors, designed for soft starting and stopping of three-phase motors for centrifugal fans. The starting time, the stopping time and the initial torque are adjusted by mean of independent potentiometers.



Return fan

Used to overcome high return path pressure drops, works in series with the indoor fan to maintain the air pressure of the conditioned space within acceptable levels. (Only available in models ARx 45-90).

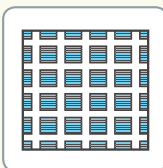

Grill condenser protection

Metallic frame painted with oven-baked polymerized paint (800h salt spray resistance) to protect the fins of the coils from external damages.

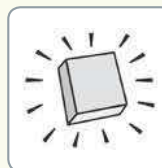

Air filters

G4, F6 and F7 filters are available to purify the air in the room. M1 fire class and manufactured in sheet metal frame, they are easy to install and clean.

VITALITY Axial Fan Large Split

VAC/VAH - VIR 20 to 90 AB

A complete range from 19.1 kW up to 86.1 kW



Features

- New YKN2open board
- High technology fan blades increases efficiency and reduces noise level
- Service valves
- Economizer or motorized damper
- Return fan
- Indoor air quality
- Hot water coil and control
- Scroll compressor with crankcase heater
- Digital thermostat DPC-1 included

V A H 40 A B Nomenclature

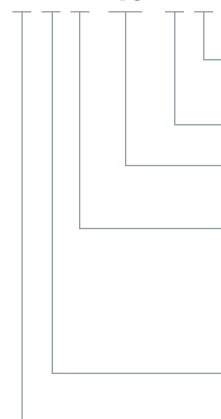

B = Blue fin
C = Copper fin (ask JCI)

A = version

Capacity range:
40 = 40 kW

Product category:

C = Cooling only

H = Heat Pump

R = Reversible

I = Indoor

A = Axial

V = Vitality



VITALITY Axial Fan Large Split

VAC/VAH - VIR 20 to 90 AB

Technical features

INDOOR UNITS										
Cooling only and Heat pump	VIR	25AB	40AB	45AB	60AB	75AB	90AB			
OUTDOOR UNITS										
Cooling only models	VAC	20AB	25AB	30AB	40AB	45AB	60AB	75AB	90AB	
Cooling capacities	kW	19.10	23.00	28.80	35.10	42.90	54.00	72.30	86.10	
Power input in cooling	kW	5.60	6.99	9.60	11.62	13.53	18.60	23.09	28.60	
EER (4)		3.41	3.29	3.00	3.02	3.17	2.90	3.13	3.01	
Refrigerant charge on site for 7 m piping length	kg	12	12	12.5	13.5	2 x 11	2 x 11.5	2 x 15.5	2 x 15	
Heat pump models	VAH	20AB	25AB	30AB	40AB	45AB	60AB	75AB	90AB	
Cooling capacities	kW	19.10	23.00	28.80	35.10	42.90	52.10	72.30	86.10	
Power input in cooling	kW	5.60	6.99	9.60	11.62	13.53	18.60	23.09	28.60	
EER (4)		3.41	3.29	3.00	3.02	3.17	2.80	3.13	3.01	
Heating capacities	kW	21.20	25.20	31.90	41.00	44.80	59.40	81.00	93.10	
Power input in heating	kW	4.94	6.73	8.41	12.09	12.69	17.06	22.13	28.82	
COP (4)		4.29	3.74	3.79	3.39	3.53	3.48	3.66	3.23	
Refrigerant charge on site for 7 m piping length	kg	12	12	12.5	13.5	2 x 11	2 x 11.5	2 x 15.5	2 x 15	
Power supply	400V/3 + N/ 50Hz									
Nominal / Starting current	A	8.5 / 74	11.8 / 95	15 / 118	19.3 / 140	2 x 12 / 95	2 x 15 / 118	2 x 19 / 140	2 x 25 / 198	
Main switch (1)	A	20	25	32	40	50	63	80	100	
Main cable to the outdoor unit (1)	Nbr x mm ²	5 x 4	5 x 4	5 x 6	5 x 10	5 x 10	5 x 16	5 x 25	5 x 35	
Interconnecting cable (1)	Nbr x mm ²	4 x 1.5	4 x 1.5	4 x 1.5	4 x 1.5	4 x 1.5	4 x 1.5	4 x 1.5	4 x 2.5	
Cable to standard thermostat (2)	Nbr x mm ²	10 x 0.22								
Insulated refrigerant piping	Suction	1-1/8"	1-1/8"	1-1/8"	1-1/8"	2 x 1-1/8"	2 x 1-1/8"	2 x 1-3/8"	2 x 1-3/8"	
	Liquid	1/2"	1/2"	5/8"	5/8"	2 x 1/2"	2 x 5/8"	2 x 7/8"	2 x 7/8"	
Evaporator fan VIR at nominal airflow (3)	Airflow	m ³ /h	4 590	4 590	7 500	7 500	9 000	10 500	13 000	16 000
	Standard ESP	Pa	172		153		150	178	170	240
	ESP with HSD	Pa	267		242		203	277	289	399
	ESP with HSDM	Pa	267		242		203	277	289	399
Nett dimensions outdoor VAC / VAH	Height	mm	1 230	1 230	1 382	1 378	1 378 / 1 429	1 378 / 1 429	1 534	1 534
	Length	mm	882	882	882	1 627	1 627	1 627	1 627	1 627
	Depth	mm	1 354	1 354	1 354	1 453	1 453	1 453	2 099	2 099
Nett dimensions indoor VIR	Height	mm	592		665		764	764	838	838
	Length	mm	1360		1740		2240	2240	2653	2653
	Depth	mm	785		785		772	772	892	892
Nett weight	VAC / VAH	kg	227	228	250	355	470	483	610	610
	VIR	kg	128		173		223	223	310	312

(1) For information only. These should be checked for compliance with local regulations depending also on installation and conductor type.

(2) Shield type cable only.

(3) ESP = External static pressure HSD = High speed drive HSDM = High speed drive and motor

(4) All the data are at EUROVENT conditions with 400V/3+N/50Hz.

Cooling : Entering indoor coil temp. 27°C / 19°C WB and outdoor temperature 35°C

Heating : Entering indoor coil temp. 20°C and outdoor temperature 7°C / 6°C WB

Codes

INDOOR UNITS								
Cooling only & heat pump models	VIR 25 AB		VIR 40 AB		VIR 45 AB	VIR 60 AB	VIR 75 AB	VIR 90 AB
		S662562575		S662564075		S662564575	S662566075	S662567575
OUTDOOR UNITS								
Cooling only models	VAC 20 AB	VAC 25 AB	VAC 30 AB	VAC 40 AB	VAC 45 AB	VAC 60 AB	VAC 75 AB	VAC 90 AB
	S661502073	S661502573	S661503073	S661504173	S661504673	S661506173	S661507673	S661509173
Heat pump models	VAH 20 AB	VAH 25 AB	VAH 30 AB	VAH 40 AB	VAH 45 AB	VAH 60 AB	VAH 75 AB	VAH 90 AB
	S662512073	S662512573	S662513073	S662514173	S662514673	S662516273	S662517673	S662519173
Thermostat								
Delivered with the unit				DPC-1				



Manufacturer reserves the rights to change specifications without prior notice.

Accessories or options

Compatibility table / Codes

INDOOR UNITS									
Cooling only & heat pump		VIR 25 AB		VIR 40 AB		VIR 45 AB	VIR 60 AB	VIR 75 AB	VIR 90 AB
		S662562575		S662564075		S662564575	S662566075	S662567575	S662569075
OUTDOOR UNITS									
Cooling only models		VAC 20 AB	VAC 25 AB	VAC 30 AB	VAC 40 AB	VAC 45 AB	VAC 60 AB	VAC 75 AB	VAC 90 AB
		S661502073	S661502573	S661503073	S661504173	S661504673	S661506173	S661507673	S661509173
Heat pump models		VAH 20 AB	VAH 25 AB	VAH 30 AB	VAH 40 AB	VAH 45 AB	VAH 60 AB	VAH 75 AB	VAH 90 AB
		S662512073	S662512573	S662513073	S662514173	S662514673	S662516273	S662517673	S662519173
Thermostat									
Delivered with the unit		DPC-1							
YNK2Open Gateway BACnet / IP - JCI Metasys N2 **		S606791244	A	A	A	A	A	A	A
YNK2Open Gateway Modbus TCP / IP - JCI Metasys N2 **		S606791245	A	A	A	A	A	A	A
Accessories or options for outdoor units									
		20AB	25AB	30AB	40AB	45AB	60AB	75AB	90AB
Low Ambient Kit		S606819974	O	O	O	O			
		S606819975					O	O	O
Soft start compressor		S606744692	O	O	O	O			
		S606744693					O	O	O
Alarm relay board		S606791243	O/A	O/A	O/A	O/A	O/A	O/A	O/A
Copper-copper coil		Contact us	O	O	O	O	O	O	O
Accessories or options for indoor units									
VIR models		25A	40AB	45AB	60AB	75AB	90AB		
Electrical Heaters (Inside the unit) (cable 20 m included)		10 kW (1 stage)	S611763704	O/A					
		15 kW (1 stage)	S611763714	O/A					
50 m connecting cable		10 kW (1 stage)	S611763724		O/A				
		20 kW (2 stages)	S611763734		O/A				
		15 kW (1 stage)	S611763744			O/A	O/A		
		30 kW (2 stages)	S611763754			O/A	O/A		
		30 kW (2 stages)	S611763764					O/A	O/A
		40 kW (2 stages)	S611763774					O/A	O/A
Economizer or Motorised damper (dry bulb sensors included) (cable 20 m included)		1 stage	S611763780	A	A	A	A		
		2 stages	S611763781		A	A	A	A	A
Indoor air quality		S613994250	A						
		S613994400		A					
		S613994450			A	A			
Hot water coil and control (cable 20 m included)		S613994750					A	A	
		S606819964	A	A	A	A	A	A	A
		S611082513	O						
50 m communication cable (Economizer/HWC)		S611084010		O					
		S611084512			O	O			
		S611087510					O	O	
Return fan		S611087520 *	A	A	A	A	A	A	A
		S613995450			A	A			
Vertical discharge Kit		S613995750					A	A	
		S669482502	O						
		S669484002		O					
Indoor fan smooth start up to 5,5 kW		S669486002			O	O			
		S669487502					O	O	
		S606744690	O	O	O	O	O	O	O
High speed drive		S611991087	O						
		S611991089		O					
		S611991091			O			O	
		S611991092				O			
High speed drive and motor		S611991095							O
		S611991088	O						
		S611991090			O				
		S611991093				O			
High speed drive and motor		S611991094					O		
		S611991096						O	
		S611991096							O

O = Option (factory fitted) A = Accessory (supplied loose) O/A = If you want this item factory fitted, precise it in the order form

(1) Factory fitted, for horizontal airflow only.

* If the unit is equipped with economizer and hot water coil, only 1 communication cable is necessary.

** To be released in 2016 - Ask JCI for availability

Indoor units dimensions



VIR 25 AB

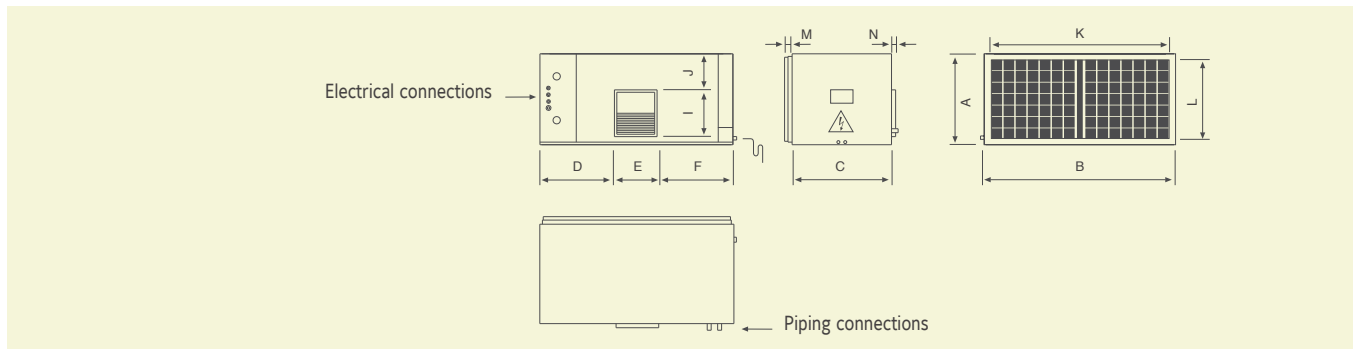

All dimensions in mm. Drawings not a scale.

Unit	A	B	C	D	E	F	G	H	I	J	K	L	M	N
VIR 25 AB	592	1360	785	480	403	480	-	-	347	40	1094	520	21	25

VIR 40-45-60 AB

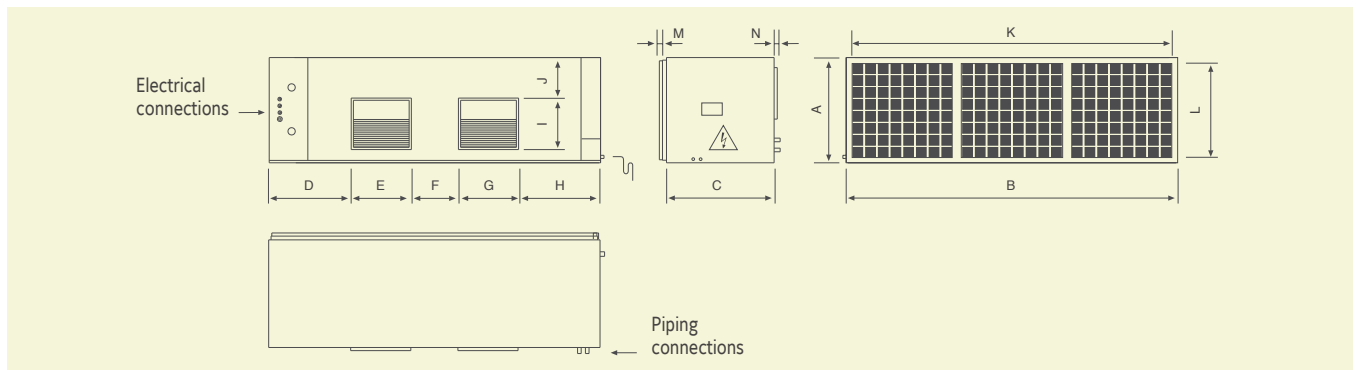

All dimensions in mm. Drawings not a scale.

Unit	A	B	C	D	E	F	G	H	I	J	K	L	M	N
VIR 40 AB	665	1740	785	442	316	229	316	442	347	79	1337	593	21	25
VIR 45 AB	764	2240	772	567	401	309	401	567	347	79	1920	692	21	25
VIR 60 AB	764	2240	772	567	401	309	401	567	347	79	1920	692	21	25

VIR 75-90 AB

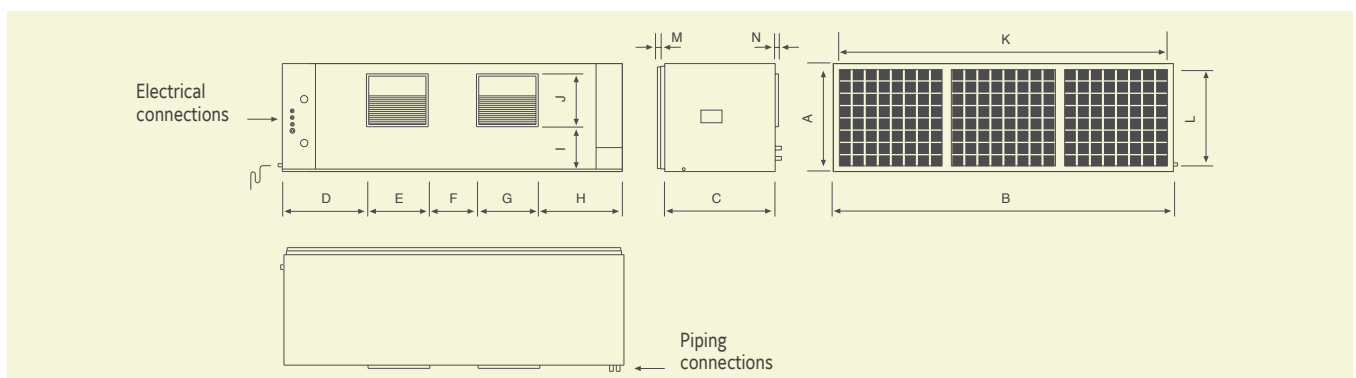

All dimensions in mm. Drawings not a scale.

Unit	A	B	C	D	E	F	G	H	I	J	K	L	M	N
VIR 75 AB	838	2653	892	663	478	376	478	663	409	79	2196	766	21	25
VIR 90 AB	838	2653	892	663	478	376	478	663	409	79	2196	766	21	25

Dimensions and space requirements for outdoor units

VAC-VAH 20-25-30 AB

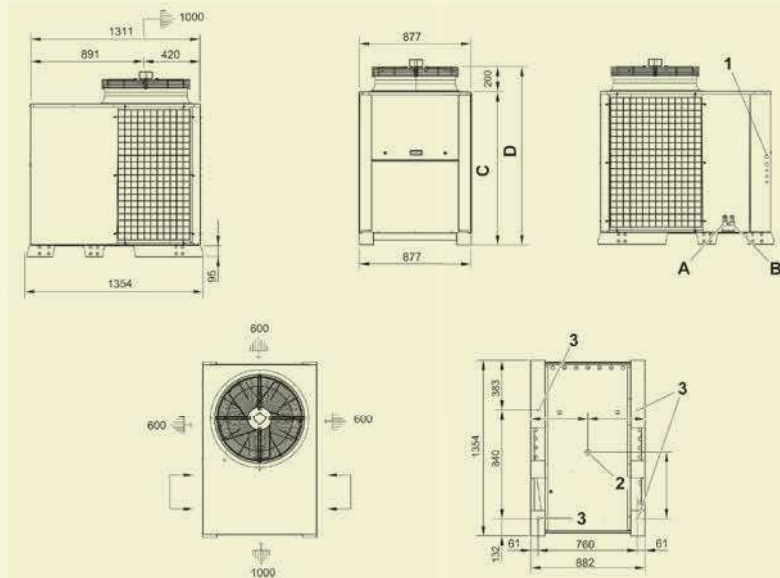

All dimensions in mm. Drawings not a scale.

VAC-VAH 40-45-60 AB

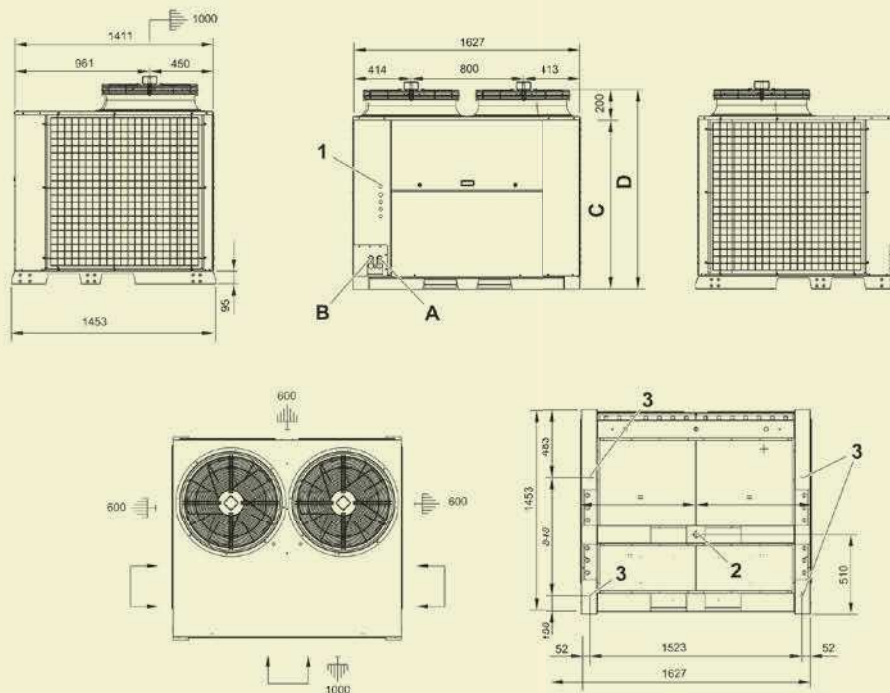

All dimensions in mm. Drawings not a scale.



VAC-VAH 75-90 AB

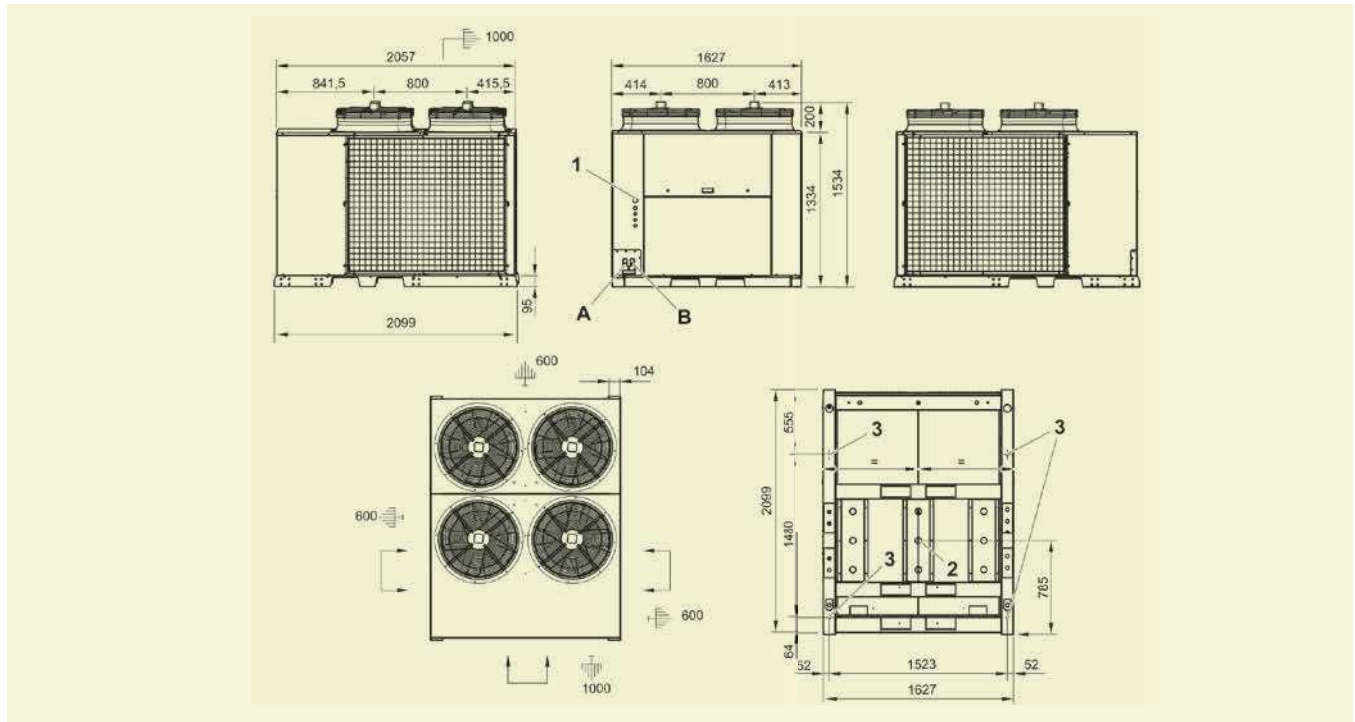

All dimensions in mm. Drawings not a scale.

VAC-VAH 20-25-30 AB

	A	B	C	D
Unit	Gas piping diameter	Liquid piping diameter	mm	mm
VAC 20 AB	1-1/8"	1/2"	1 030	1 230
VAH 20 AB	1-1/8"	1/2"	1 030	1 230
VAC 25 AB	1-1/8"	1/2"	1 030	1 230
VAH 25 AB	1-1/8"	1/2"	1 030	1 230
VAC 30 AB	1-1/8"	5/8"	1 182	1 382
VAH 30 AB	1-1/8"	5/8"	1 182	1 382

VAC-VAH 40-25-60 AB

	A	B	C	D
Unit	Gas piping diameter	Liquid piping diameter	mm	mm
VAC 40 AB	1-1/8"	5/8"	1 178	1 378
VAH 40 AB	1-1/8"	5/8"	1 178	1 378
VAC 45 AB	2 x 1-1/8"	2 x 1/2"	1 178	1 378
VAH 45 AB	2 x 1-1/8"	2 x 1/2"	1 129	1 429
VAC 60 AB	2 x 1-1/8"	2 x 5/8"	1 178	1 378
VAH 60 AB	2 x 1-1/8"	2 x 5/8"	1 129	1 429

VAC-VAH 40-25-60 AB

	A	B	C	D
Unit	Gas piping diameter	Liquid piping diameter	mm	mm
VAC 75 AB	2 x 1-3/8"	2 x 7/8"	-	-
VAH 75 AB	2 x 1-3/8"	2 x 7/8"	-	-
VAC 90 AB	2 x 1-3/8"	2 x 7/8"	-	-
VAH 90 AB	2 x 1-3/8"	2 x 7/8"	-	-

VITALITY Centrifugal Large Split

VCH-VIR 20 to 90 AB

A complete range from 16.8 kW up to 87.3 kW



YKN2open

Features

- New YKN2open board
- High efficiency EER and COP
- Economizer or motorized damper
- Indoor air quality
- Hot water coil and control
- Scroll compressor with crankcase heater
- Possibility to be installed outdoor
- Return fan
- Digital thermostat DPC-1 included

VCH 40 AB

Nomenclature*

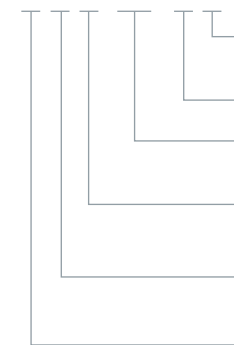

B = Blue fin
C = Copper fin (ask JCI)

A = version

Capacity range:
40 = 40 kW

Product category:

H = Heat Pump
R = Reversible
C = Centrifugal
I = Indoor

V = Vitality

* Check codes in next page for discharge configuration

VIR - Indoor unit details

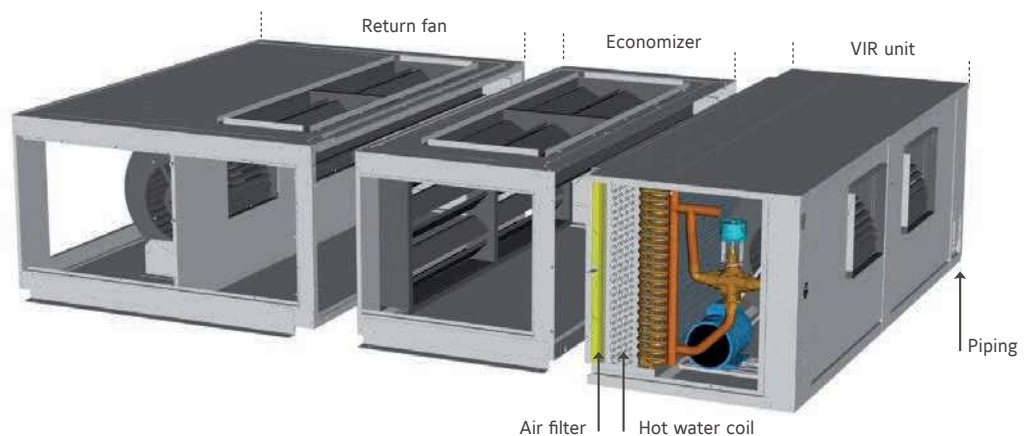

VITALITY Centrifugal Large Split

VCH-VIR 20 to 90 AB



Technical features

VITALITY UNITS										
Heat pump models	VCH/VIR	20 AB	25 AB	30 AB	40 AB	45 AB	60 AB	75 AB	90 AB	
Cooling capacities	kW	16.8	20.6	28.7	32.4	43.5	54.1	76.1	87.3	
Power input in cooling	kW	5.9	7.48	10.25	12.81	14.81	20.86	29.21	34.92	
EER		2.85	2.75	2.8	2.53	2.94	2.6	2.61	2.5	
Heating capacities	kW	21.5	23.2	32.3	39.3	47.4	53	77.7	89.9	
Power input in heating	kW	5.68	6.84	9.95	12.87	13.75	20	27.56	33.19	
COP		3.79	3.39	3.25	3.05	3.45	2.8	2.82	2.71	
Refrigerant charge on site for 7m piping length	kg	8.5	8.5	12	12	2 x 9.5	2 x 10.5	2 x 15	2 x 16	
Power supply		400V/3 + N/ 50Hz								
Nominal / Starting current	A	13 /	16 /	22 /	27 /	33 /	43 /	59 /	72 /	
Main switch (1)	A	20	25	32	40	50	63	80	100	
Main cable to the condensing unit (1)	Nbr x mm ²	5 x 4	5 x 4	5 x 6	5 x 10	5 x 10	5 x 16	5 x 25	5 x 35	
Interconnecting cable (1)	Nbr x mm ²	4 x 1.5	4 x 1.5	4 x 1.5	4 x 1.5	4 x 1.5	4 x 1.5	4 x 1.5	4 x 2.5	
Cable to standard thermostat (1) (2)	Nbr x mm ²	10 x 0.22								
Insulated refrigerant piping	Suction	1 1/8"	1 1/8"	1 1/8"	1 1/8"	2 x 1 1/8"	2 x 1 1/8"	2 x 1 3/8"	2 x 1 3/8"	
	Liquid	1/2"	1/2"	5/8"	5/8"	2 x 1/2"	2 x 5/8"	2 x 7/8"	2 x 7/8"	
Evaporator fan VIR at nominal airflow (3)	Airflow	m ³ /h		4 590	7 500		9000	10500	13700	16000
	Standard ESP	Pa		117	118		130	137	125	175
	ESP with HSD	Pa		-	217		188	246	260	-
	ESP with HSDM	Pa		222	-		188	246	260	354
Condenser fan at nominal airflow	Airflow	m ³ /h		6235	6235	11975	11975	17250	20340	25200
	Standard ESP	Pa		50	50	50	50	50	50	50
Nett dimensions VCH condensing units	Height	mm		1392	1392	1526	1526	1641	1641	1794
	Length	mm		1362	1362	1740	1740	2240	2240	2658
	Depth	mm		790	790	785	785	778	778	897
Nett dimensions VIR indoor units	Height	mm		592		665		764	764	838
	Length	mm		1360		1740		2240	2240	2653
	Depth	mm		785		785		772	772	892
Nett weight	VCH	kg		285	310	355	375	578	589	710
	VIR	kg		128		173		223	223	310

(1) For information only. These should be checked for compliance with local regulations depending also on installation and conductor type.

(2) Shield type cable will have a better insulation against electromagnetic interference. It is recommended for sensitive sites and for communications.

(3) ESP = External static pressure HSD = High speed drive HSDM = High speed drive and motor

All the data are at EUROVENT conditions with 400V/3+N/50Hz.

Cooling : Entering indoor coil temp. 27°C / 19°C WB and outdoor temperature 35°C

Heating : Entering indoor coil temp. 20°C and outdoor temperature 7°C / 6°C WB

Codes

INDOOR UNITS								
Cooling only & heat pump models	VIR 25 AB		VIR 40 AB		VIR 45 AB	VIR 60 AB	VIR 75 AB	VIR 90 AB
		S662562575		S662564075		S662564575	S662566075	S662567575
OUTDOOR UNITS								
Heat pump models	VCH 20 AB	VCH 25 AB	VCH 30 AB	VCH 40 AB	VCH 45 AB	VCH 60 AB	VCH 75 AB	VCH 90 AB
with horizontal discharge	S662512043	S662512653	S662513043	S662514044	S662514543	S662516153	S662517543	S662519043
with vertical discharge	-	-	-	-	S662514565	S662516174	S662517564	S662519064
Thermostat								
Delivered with the unit	DPC-1							



Manufacturer reserves the rights to change specifications without prior notice.

Accessories or options

Compatibility table / Codes

INDOOR UNITS									
Cooling only & heat pump models		VIR 25 AB	VIR 40 AB	VIR 45 AB	VIR 60 AB	VIR 75 AB	VIR 90 AB		
		S662562575	S662564075	S662564575	S662566075	S662567575	S662569075		
OUTDOOR UNITS									
Heat pump models		VCH 20 AB	VCH 25 AB	VCH 30 AB	VCH 40 AB	VCH 45 AB	VCH 60 AB	VCH 75 AB	VCH 90 AB
with horizontal discharge		S662512043	S662512653	S662513043	S662514044	S662514543	S662516153	S662517543	S662519043
with vertical discharge		-	-	-	-	S662514565	S662516174	S662517564	S662519064
Thermostat									
Delivered with the unit		DPC-1							
YNK2Open Gateway BACnet / IP - JCI Metasys N2 ****	S606791244	A	A	A	A	A	A	A	A
YNK2Open Gateway Modbus TCP / IP - JCI Metasys N2 ****	S606791245	A	A	A	A	A	A	A	A
Accessories or options for condensing units									
VCH models		20 AB	25 AB	30 AB	40 AB	45 AB	60 AB	75 AB	90 AB
Low ambient regulation *	S613112583	0	0						
	S613114084			0	0				
	S613116084					0	0		
	S613111084							0	0
Vertical discharge kit	S612828305	0	0						
	S612828405			0	0				
	S612828505 **					0			
	S612828605 **						0		
Condensate tray heater	S612828205 **							0	0
	S611080789	A	A	A	A				
	S611080790					A	A	A	A
Alarm relay board	S606791243	O/A	O/A	O/A	O/A	O/A	O/A	O/A	O/A
Copper-copper coil	Contact us	0	0	0	0	0	0	0	0
Accessories or options for indoor units									
VIR models		25 AB	40 AB	45 AB	60 AB	75 AB	90 AB		
Electrical Heaters (inside the unit) (cable 20 m included)	10 kW (1 stage)	S611763704	O/A						
	15 kW (1 stage)	S611763714	O/A						
	10 kW (1 stage)	S611763724		O/A					
	20 kW (2 stages)	S611763734		O/A					
	15 kW (1 stage)	S611763744			O/A	O/A			
	30 kW (2 stages)	S611763754			O/A	O/A			
	30 kW (2 stages)	S611763764					O/A	O/A	
50 m connecting cable	40 kW (2 stages)	S611763774					O/A	O/A	
	1 stage	S611763780	A	A	A	A	A	A	
Economizer or Motorised damper (dry bulb sensors included) (cable 20 m included)	2 stages	S611763781		A	A	A	A	A	A
		S613994250	A						
		S613994400		A					
		S613994450			A	A			
Indoor air quality	S613994750						A	A	
	S606819964	A	A	A	A	A	A	A	
Hot water coil and control (cable 20 m included)	S611082513	0							
	S611084010		0						
	S611084512			0	0				
50 m communication cable (Economizer/HWC)	S611087510						0	0	
	S611087520 ***	A	A	A	A	A	A	A	
Return fan	S613995450			A	A				
	S613995750						A	A	
Vertical discharge Kit	S669482502	0							
	S669484002		0						
	S669486002				0	0			
Indoor fan smooth start up to 5,5 kW	S669487502						0	0	
	S606744690	0	0	0	0	0	0	0	
High speed drive	S611991087	0							
	S611991089		0						
	S611991091				0		0		
	S611991092					0			
	S611991095								0
High speed drive and motor	S611991088	0							
	S611991090				0				
	S611991093					0			
	S611991094						0		
	S611991096							0	

O = Option (factory fitted). A = Accessory (supplied loose). O/A = If you want this item factory fitted, precise it in the order form.

* Not protected against external condition. ** To be used only with horizontal discharge models

*** If the unit is equipped with economizer and hot water coil, only 1 communication cable is necessary. **** To be released in 2016 - Ask JCI for availability

Indoor units dimensions



VIR 25 AB

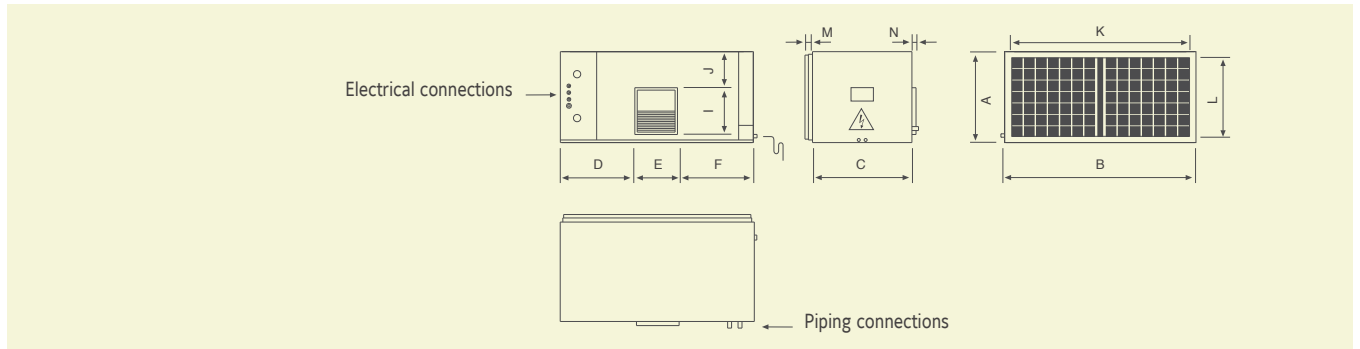

All dimensions in mm. Drawings not a scale.

Unit	A	B	C	D	E	F	G	H	I	J	K	L	M	N
VIR 25 AB	592	1360	785	480	403	480	-	-	347	40	1094	520	21	25

VIR 40-45-60 AB

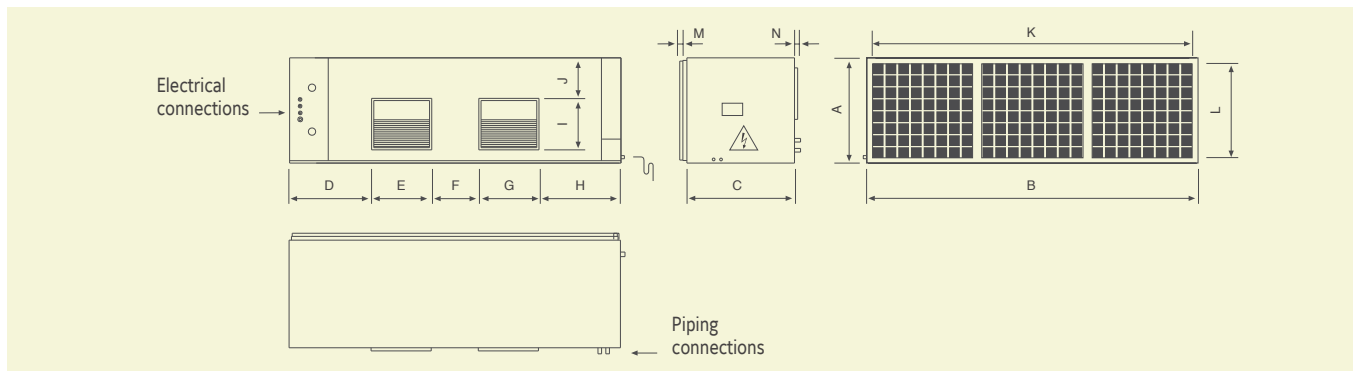

All dimensions in mm. Drawings not a scale.

Unit	A	B	C	D	E	F	G	H	I	J	K	L	M	N
VIR 40 AB	665	1740	785	442	316	229	316	442	347	79	1337	593	21	25
VIR 45 AB	764	2240	772	567	401	309	401	567	347	79	1920	692	21	25
VIR 60 AB	764	2240	772	567	401	309	401	567	347	79	1920	692	21	25

VIR 75-90 AB

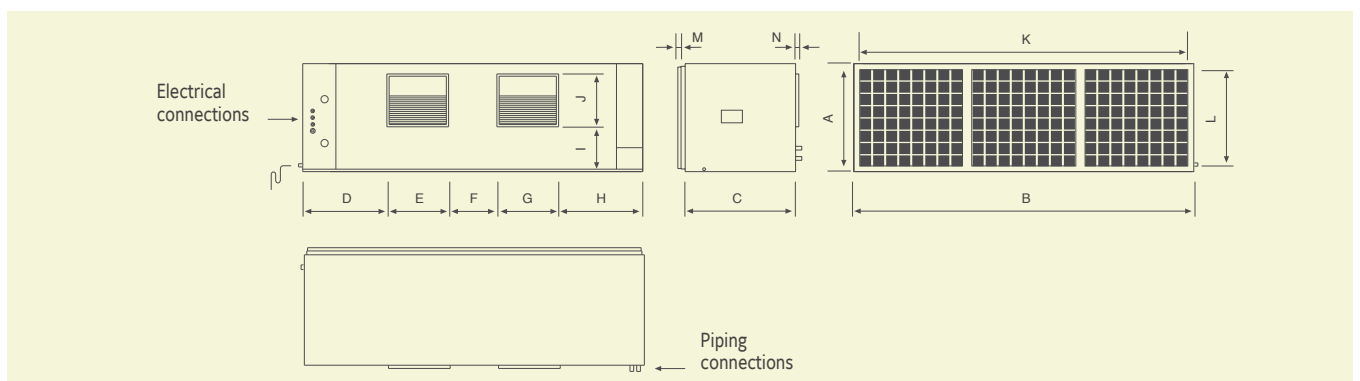

All dimensions in mm. Drawings not a scale.

Unit	A	B	C	D	E	F	G	H	I	J	K	L	M	N
VIR 75 AB	838	2653	892	663	478	376	478	663	409	79	2196	766	21	25
VIR 90 AB	838	2653	892	663	478	376	478	663	409	79	2196	766	21	25

Dimensions and space requirements for condensing units

VCH 20-25 AB

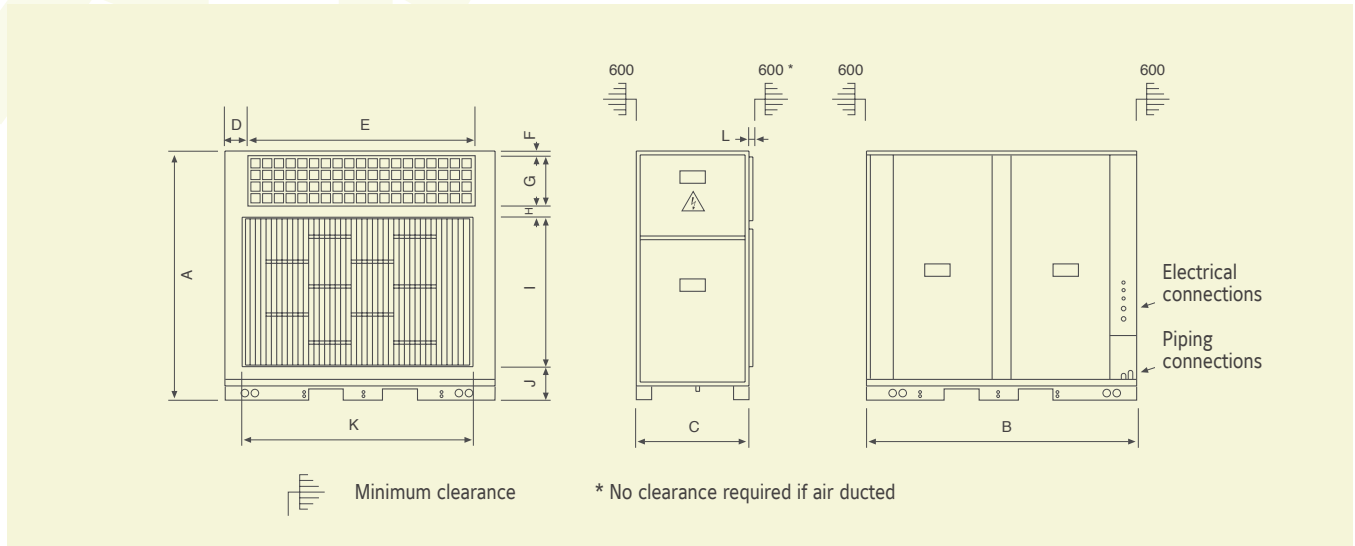

All dimensions in mm. Drawings not a scale.

Unit	A	B	C	D	E	F	G	H	I	J	K	L
VCH 20 AB	1 392	1 362	790	147	1 069	30	268	37	919	138	1 100	24
VCH 25 AB	1 392	1 362	790	147	1 069	30	268	37	919	138	1 100	24

VCH 30-40 AB

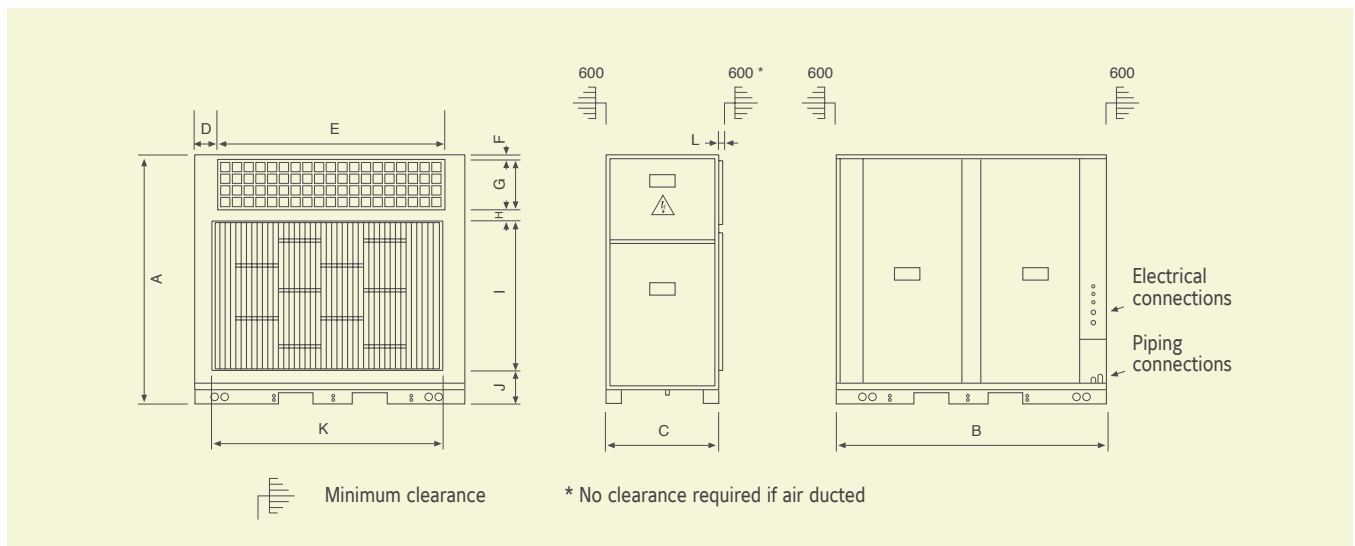

All dimensions in mm. Drawings not a scale.

Unit	A	B	C	D	E	F	G	H	I	J	K	L
VCH 30 AB	1 526	1 740	785	151	1 436	30	324	37	994	141	1 476	24
VCH 40 AB	1 526	1 740	785	151	1 436	30	324	37	994	141	1 476	24



VCH 45-60 AB

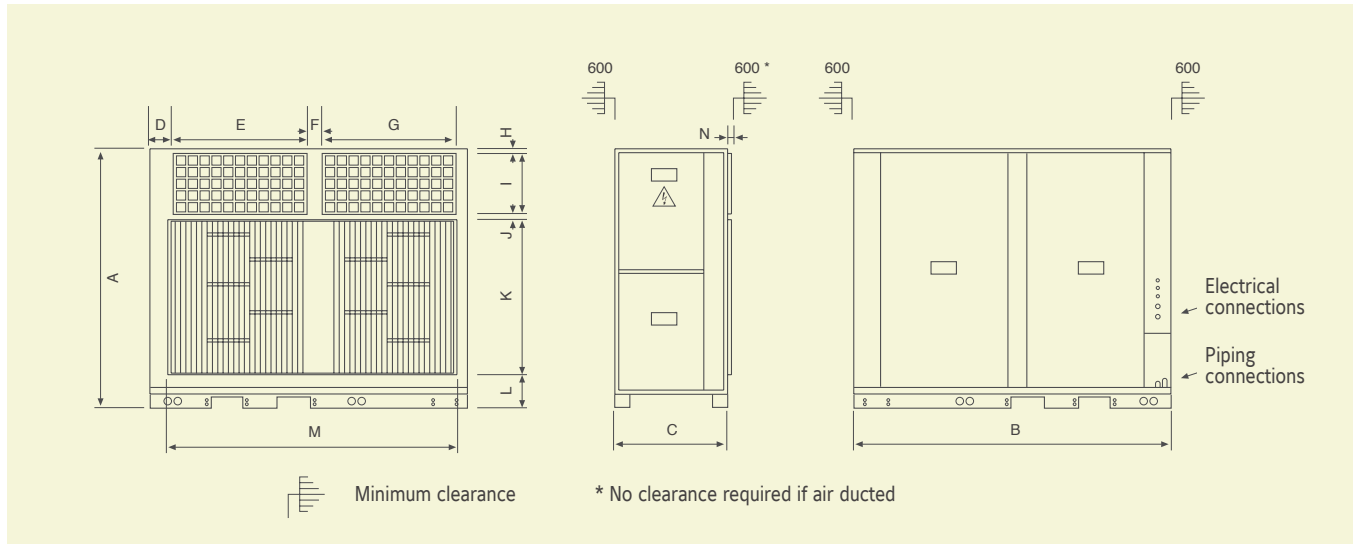

All dimensions in mm. Drawings not a scale.

Unit	A	B	C	D	E	F	G	H	I	J	K	L	M	N
VCH 45 AB	1 641	2 240	778	148	945	95	945	38	389	38	1044	140	2 060	23
VCH 60 AB	1 641	2 240	778	148	945	95	945	38	389	38	1044	140	2 060	23

VCH 75-90 AB

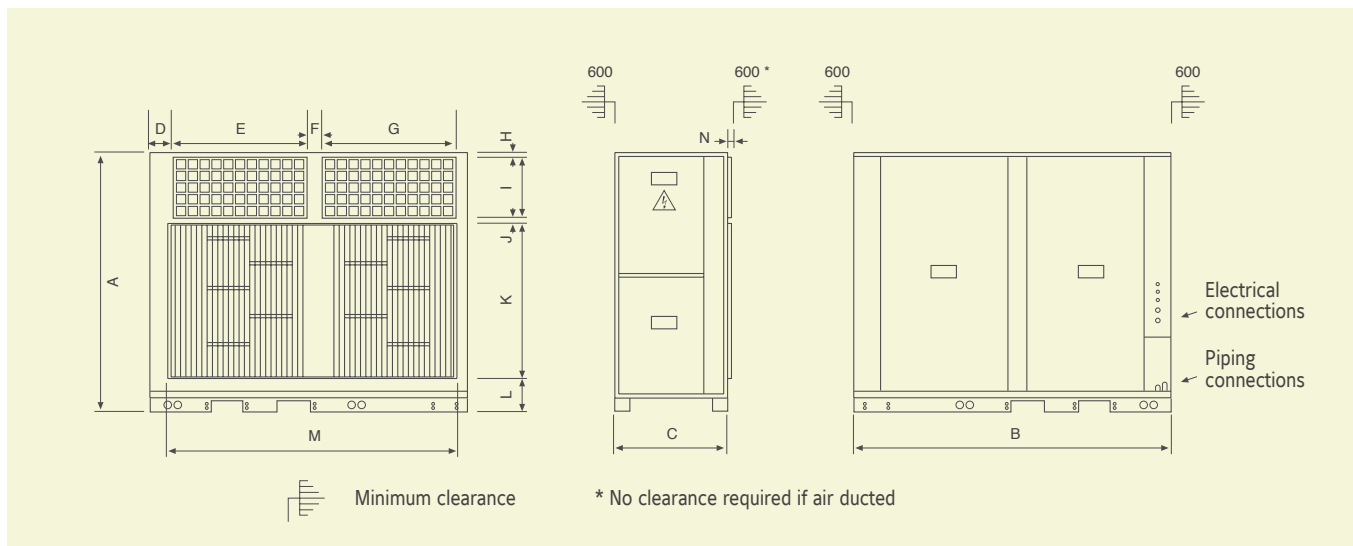

All dimensions in mm. Drawings not a scale.

Unit	A	B	C	D	E	F	G	H	I	J	K	L	M	N
VCH 75 AB	1 794	2 658	897	148	1155	95	1155	30	389	37	1 200	138	2 479	23
VCH 90 AB	1 794	2 658	897	148	1155	95	1155	30	389	37	1 200	138	2 479	23

Selection Tool for Advanced Rooftops - S.T.A.R.

Johnson Controls continues the improvement of the selection software for Packaged and Commercial Split Systems called YORK® S.T.A.R – Selection Tool for Advanced Rooftop. By installing new releases, available through Virtual Branch portal, the selection tool is updated periodically with the aim to help and simplify the product selection and quotation process.

EQUIPMENT DATA SHEET			
Project name	Unit ref.	Rel. date	
Customer	Software version	Creation date	
APIC 032 NE	3.7.0.0 (Rel.)	12/12/2013	
Model: APIC 032 NE			
ACCESSORIES: - Condensate or rainwater or debris filter (not included) - Drain pan - Drain assembly - Freehead hood			
COOLING PERFORMANCE:			
Capacity (kW)	34.1 (kW)	Capacity (tonnes)	97.1 (ton)
Power input (kW)	25.1 (kW)	Net COP	1.37
Condenser coil area (m²)	13.2	Total Power input (kW)	11.9 (kW)
APIC032 NE			
Indoor coil area (m²)	37.0 (m²)	Refrigerant (kg)	40 (kg)
Indoor coil type	155 (mm)	Refrigerant (kg)	40 (kg)
Indoor coil voltage (V)	230 V	Refrigerant (kg)	40 (kg)
Outdoor coil area (m²)	25.7 (m²)	Refrigerant (kg)	40 (kg)
Outdoor coil type	155 (mm)	Refrigerant (kg)	40 (kg)
Outdoor coil voltage (V)	230 V	Refrigerant (kg)	40 (kg)
Condenser coil area (m²)	13.2	Refrigerant (kg)	40 (kg)
Condenser coil type	155 (mm)		
Condenser coil voltage (V)	230 V		
Power input (kW)	25.1 (kW)		
Power input (kVA)	32.5 (kVA)		
Power factor	0.80 (kVA)		
Available static pressure (Pa)	30 (Pa)		
COMPLETION:			
Material	1 (m)	Paint finish	1 (m)
ENVIRONMENT:			
Altitude	1 (m)	Power option	3 (m)
Power input (kW)	25.1 (kW)		
Power input (kVA)	32.5 (kVA)		
ELECTRICAL DATA:			
Power input (kW)	25.1 (kW)	Max. power input (kW)	34.1 (kW)
Power input (kVA)	32.5 (kVA)	Max. power input (kVA)	40.2 (kVA)
REVISIONS:			
Version	3.7.0.0	Release date	12/12/13
Author		Release date	12/12/13

EQUIPMENT DATA SHEET					
Project name	Unit ref.	Rel. date			
Customer	Software version	Creation date			
APIC 032 NE	3.7.0.0 (Rel.)	12/12/2013			
APIC 032 NE					
ELECTRICAL DATA:	400V/3N/3-4-0/50	Max. power input (kW)	34.1 (kW)		
	42.7 (kVA)	Max. power input (kVA)	40.2 (kVA)		
GEOMETRY DATA:					
Power input (kW)	25.1 (kW)	Max. power input (kW)	34.1 (kW)		
Power input (kVA)	32.5 (kVA)	Max. power input (kVA)	40.2 (kVA)		
DIMENSIONS AND WEIGHT:					
Height (mm)	2100 (mm)	Weight (kg)	40 (kg)		
Length (mm)	1620 (mm)	Weight (kg)	40 (kg)		
Table:					
Code	Model	Max. P (kW)	Max. Q (kW)	Max. Q (tonnes)	Setting price (€)
081715211	APIC 032 NE	34.1 (kW)	40.2 (kVA)	97.1 (ton)	30,202.00
081715212	Equivalent or increased air capacity with fan hood	34.1 (kW)	40.2 (kVA)	97.1 (ton)	3,403.00
081715213	Fan hood	700.00	1.00	700.00	
081715214	Line set (m)	432.00	1.00	432.00	
081715215	Power up P7	1,410.00	1.00	1,410.00	
081715216	Black hood (P7)	2,207.00	1.00	2,207.00	
081715217	Fan hood (P7)	1,410.00	1.00	1,410.00	
081715218	Power up (P7)	2,207.00	1.00	2,207.00	
081715219	Power up (P7)	2,207.00	1.00	2,207.00	
081715220	Free delivery (optional)	400.00	1.00	400.00	
081715221	5-Phases (optional)	400.00	1.00	400.00	
	TOTAL:	22,628.00	1.00	22,628.00	

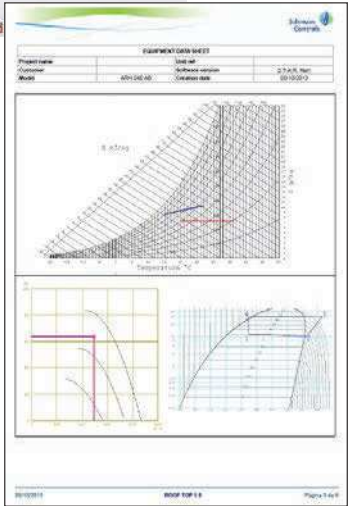

Using S.T.A.R you will be able to select:

- The ACTIVA Rooftop range units
- Roomtop units (RTC/RTH)
- Vitality Large Split units (including condenser units only)

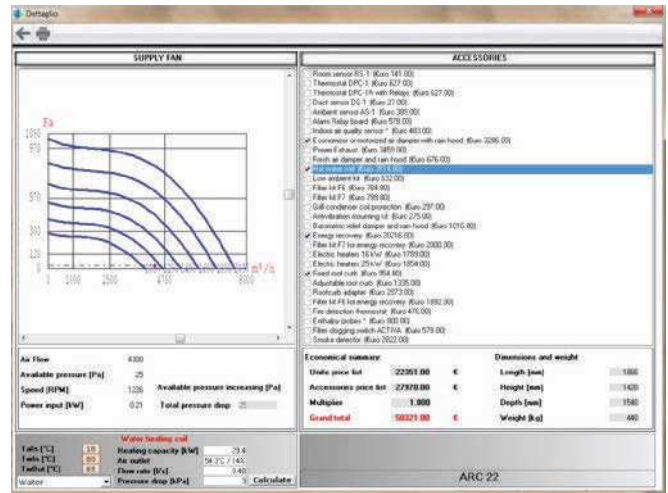
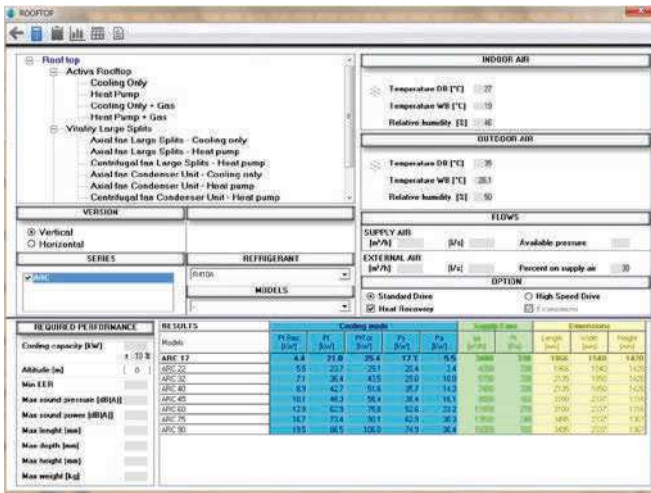

In addition, the selection of some key options is possible.

For instance: economizer, enthalpy wheel, high pressure drive, hot water coil for the ACTIVA Rooftops 17-40 and 45-90.

The tool allows extracting reports easily in different formats (editable and non editable).

S.T.A.R. is currently available in English, Spanish, Polish and Italian. The tool can be translated to other languages if required.

* Call your JCI Sales Representative and request access now.

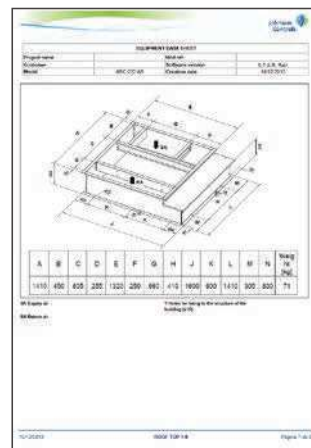
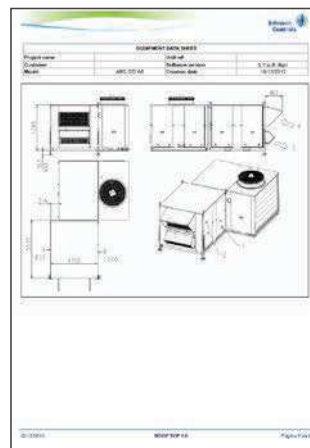
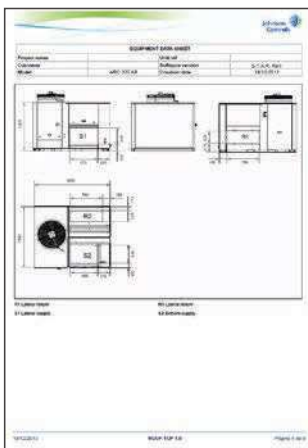
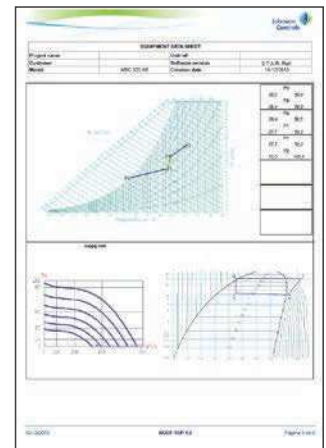



Comprehensive Solutions

INDUSTRIAL REFRIGERATION

METASYS® BUILDING AUTOMATION AND
CONTROL SYSTEMS

Industrial refrigeration



Johnson Controls Industrial Refrigeration designs, manufactures, tests, installs and commissions highly efficient and environmentally sustainable refrigeration solutions for the demanding conditions encountered in industrial environments.

HeatPAC heat pumps



Ammonia-based heat pumps using a reciprocating compressor, with a 240–1200 kW capacity range

HeatPAC units are extremely compact heat pumps based on ultra-reliable Sabroe HPO/HPC high-pressure reciprocating compressors, using ammonia as refrigerant. They are usually most cost-effective when fitted with a variable-speed drive (VSD) that makes it easy to deal with changing circumstances and different operating requirements. These highly customisable integrated units are based on a unique vibration-resistant design, featuring an uncomplicated flooded evaporating system. They provide exceptional heat pump capacity from the smallest possible footprint, and with only a very small refrigerant charge.

Sabroe HeatPAC heat pumps are the ideal solution for effectively exploiting low-temperature waste heat, and turning it into hot water (up to 70°C), using only a minimum of electrical energy. These units are designed to provide a cost-effective way to tackle needs for cooling and heating at the same time, providing an extremely high coefficient of performance (COP).

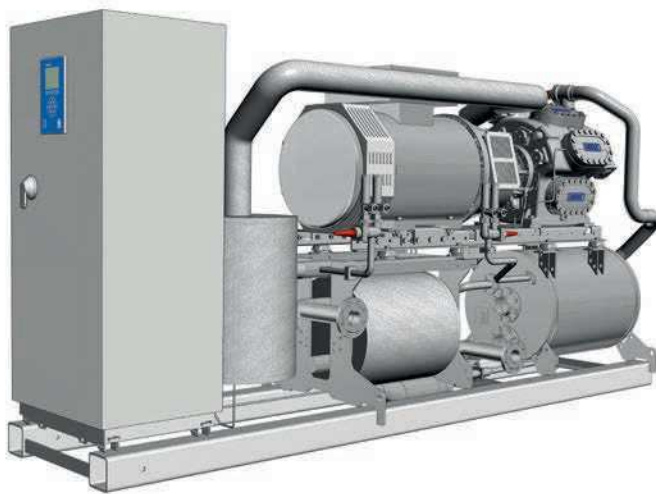

Main benefits

- High reliability – proven components
- Fast installation – quick start-up
- High efficiency – high saving potential.

Options

- Cascade evaporator
- Variable-speed drive (VSD)
- Soft-starter or Y/D starter
- De-superheater
- Subcooler
- Control panel mounted separately
- HeatPAC 24, 26 and 28: 60 Hz or VSD
- Customer-witnessed factory acceptance tests (FAT).

HeatPAC packaged ammonia heat pumps

Type	Heating capacity kW	Cooling capacity kW	Power consumption kW	COP heat	R717 charge kg	Dry weight kg	Dimensions			Sound press. level dB(A)
							L mm	W mm	H mm	
HPAC 24-W	240	202	38	6.3	20	2 020	2 800	1 000	2 000	75
HPAC 26-W	359	302	57	6.3	23	2 230	2 850	1 000	2 000	76
HPAC 28-W	484	408	77	6.3	25	2 420	2 900	1 000	2 000	77
HPAC 104-W	570	478	93	6.1	28	2 630	3 050	1 000	2 000	81
HPAC 106-W	852	715	138	6.2	37	3 300	3 750	1 000	2 000	82
HPAC 108-W	1 149	965	186	6.2	48	3 950	4 050	1 000	2 000	83

Condenser water inlet +64°C, outlet +70°C. Evaporator water inlet +39°C, outlet +34°C. Motor: 3 x 400 V / 50 Hz, 1 470 rpm

Capacities are nominal at 1500 rpm

W = Heat pump unit water/water

Sound pressure levels in free field, over reflecting plane and one meter distance from the unit.



Manufacturer reserves the rights to change specifications without prior notice.



HeatPAC HPX heat pumps



Single-stage high-pressure ammonia-based heat pumps, using a reciprocating compressor, with a 100–600 kW capacity range

Sabroe HeatPAC™ HPX heat pumps are compact units with an integrated single-stage configuration that features less than half the space and weight requirements of any other heat pump designs usually needed to achieve 90°C hot water outputs.

These energy-efficient units feature a breakthrough HPX hybrid compressor design that allows differential pressures as high as 40 bar and discharge pressures as high as 60 bar, combined with space-saving evaporator technology from the ChillPAC™ packaged ammonia chiller.

HeatPAC HPX heat pumps make it easy to produce hot water at temperatures up to 90°C, using any suitable source of low-temperature heat, with only tiny energy inputs needed.

They provide a low-cost supply of hot water at temperatures ideal for sterilisation and pasteurisation – as well as many other hygiene-sensitive functions and processes.



Options

- Cascade evaporator
- Subcooler
- Control panel mounted separately
- Customer-witnessed factory acceptance tests (FAT).

HeatPAC HPX ammonia heat pumps

Type	Heating capacity kW	Cooling capacity kW	Power consumption kW	COP heat	R717 charge kg	Dry weight kg	Dimensions			Sound press. level dB(A)
							L mm	W mm	H mm	
HeatPAC 704-W	326	249	82	4.0	25	3 500	3 500	1 000	2 100	83
HeatPAC 706-W	489	373	123	4.0	30	4 200	3 700	1 000	2 100	85
HeatPAC 708-W	652	498	164	4.0	35	5 000	4 100	1 000	2 100	86

Condenser water inlet +70°C, outlet +90°C. Evaporator water inlet +39°C, outlet +34°C. Evaporation 30°C, 16K sub-cooling.

W = Heat pump unit water/water.

VSD drive is standard.

Sound pressure levels in free field, over reflecting plane and one meter distance from the unit.

HeatPAC heat pumps

Ammonia-based heat pumps using a screw compressor, with a capacity of up to 1800 kW



HeatPAC units are extremely compact heat pumps based on ultra-reliable Sabroe high-pressure screw compressors, using ammonia as refrigerant.

These highly customisable integrated units, featuring an uncomplicated flooded evaporating system, provide exceptional heat pump capacity from the smallest possible footprint, and with only a very small refrigerant charge. They are designed to provide a cost-effective way to tackle needs for cooling and heating at the same time, providing an extremely high coefficient of performance (COP).

Sabroe HeatPAC heat pumps are the ideal solution for effectively exploiting low-temperature waste heat, and turning it into hot water (up to 90°C), using only a minimum of electrical energy.

Sabroe HeatPAC heat pumps provide considerable scope for customisation to meet specific customer requirements.

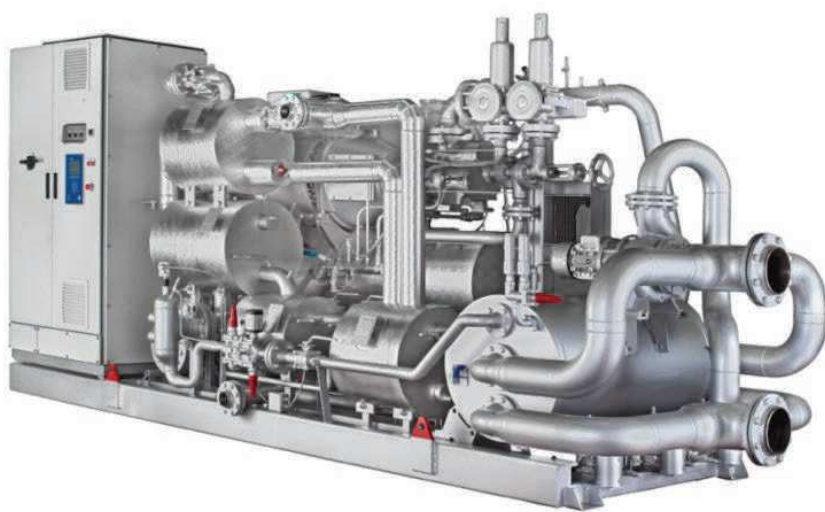

Main benefits

- High reliability – proven components
- Fast installation – quick start-up
- High efficiency – high saving potential.

Options

- Cascade evaporator
- Control panel mounted separately
- Customer-witnessed factory acceptance tests (FAT).

Compliance

All HeatPAC heat pumps are fully compliant with appropriate major international design codes and the specifications laid down by the most common classification societies. Approval in accordance with other technical requirements, specific national legislation or other classification societies' requirements is available on request.

The HeatPAC 157 HR is a versatile heat pump that can cope with a wide range of operating conditions. These units are particularly efficient under part-load conditions due to the variable-speed drive (1000-6000 rpm) fitted as standard.

Each unit is specially configured to comply with the specific set of operating conditions, in order to ensure the most effective exploitation of the waste heat available.

HeatPAC 157 HR

	Cold side					Hot side				Power motor kW	COP
	Temperature in °C	Temperature out °C	Flow m³/h	Cooling capacity kW		Temperature in °C	Temperature out °C	Flow m³/h	Heating capacity kW		
Water	40	35.9	300	1 422	Water	40	85	34.8	1 792	407	4.4
Water	30	26.8	300	1 107	Water	40	85	28.2	1 453	381	3.8
Water	20	17.6	300	818	Water	40	85	22.0	1 121	335	3.3
Water	10	8.3	300	588	Water	40	85	16.5	852	290	2.9

Capacities are nominal at 6000 rpm. Specific capacity must be calculated for actual running conditions.



Manufacturer reserves the rights to change specifications without prior notice.



ComPAC chillers

Packaged ammonia chillers based on screw compressors, with a 500–2000 kW capacity range



Sabroe ComPAC ammonia chillers based on plate-and-shell heat exchangers and the comprehensive Sabroe screw compressor programme (SAB 120–151 to SAB 193–233 and SABflex) are distinctive for their compactness. Frequency converter and panel solutions are supplied as standard.

ComPAC chillers with capacities below 1200 kW use the ultra-compact and extremely low-charge Sabroe-patented plate-and-shell heat exchangers. Chillers with capacities above 1200 kW use condensers and evaporators of premium quality, integrated into a unique vibration-resistant design.

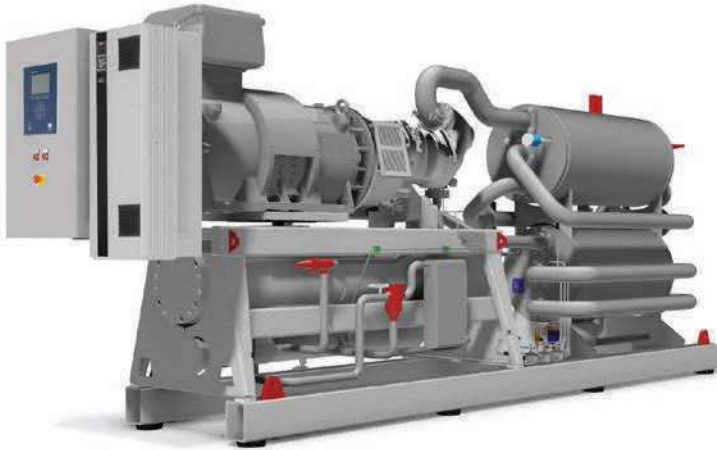

Range

There are 12 different standard models in this range of ComPAC chillers – both high- and low-temperature versions. A comprehensive range of equipment options are available to ensure performance and application versatility.

Options

- Variable-speed drive (VSD)
- Soft-starter or Y/D starter
- Sound enclosure for outdoors mounting
- External condenser
- Control panel mounted separately
- Economiser option for low-temperature brine
- Customer-witnessed factory acceptance tests (FAT)
- Heater package for low-temperature operation
- Shunt solution for high-temperature difference.

ComPAC water chillers (water: inlet +12°C, outlet +7°C)

Type	Cooling capacity kW	E-motor	R717 charge kg	Dry weight kg	Dimensions in mm			Sound level dB(A)
					L	W	H	
ComPAC 120 S-A	200	55	20	3600	5500	1200	2200	85
ComPAC 120 M-A	330	75	25	3800	5500	1200	2200	86
ComPAC 120 L-A	420	90	30	4000	5500	1200	2200	87
ComPAC 120 E-A	540	132	35	4200	5500	1200	2200	89
ComPAC Flex-A	575	160	40	5700	5500	1200	2200	89
ComPAC 151 S-A	630	142	40	5500	5500	1200	2200	91
ComPAC 151 M-A	750	172	45	5800	5500	1200	2200	92
ComPAC 151 L-A	945	223	55	5900	5500	1200	2200	92
ComPAC 151 E-A	1140	250	65	6300	5500	1200	2200	93
ComPAC 193 S-A	1100	250	65	7100	6500	1500	2200	85
ComPAC 193 L-A	1420	315	75	7400	6500	1500	2200	85
ComPAC 233 S-A	2000	400	330	12000	7000	1500	2500	86
ComPAC 233 L-A	2200	500	350	13000	7000	1500	2500	86

120 S operates at 1470 rpm

ComPAC brine chillers (Ethylene glycol 30%: inlet -4°C, outlet -8°C)

Type	Cooling capacity kW	E-motor	R717 charge kg	Dry weight kg	Dimensions in mm			Sound level dB(A)
					L	W	H	
ComPAC 120 S-C	115	45	20	3653	5500	1200	2200	85
ComPAC 120 M-C	185	75	25	3818	5500	1200	2200	86
ComPAC 120 L-C	235	90	30	3997	5500	1200	2200	87
ComPAC 120 E-C	310	117	35	4428	5500	1200	2200	89
ComPAC Flex-C	340	132	45	5667	5500	1200	2200	89
ComPAC 151 S-C	360	132	40	5304	5500	1200	2200	91
ComPAC 151 M-C	430	160	45	5584	5500	1200	2200	92
ComPAC 151 L-C	540	200	55	5833	5500	1200	2200	92
ComPAC 151 E-C	605	250	45	5824	5500	1200	2200	93
ComPAC 193 S-C	610	200	60	6836	6500	1500	2200	85
ComPAC 193 L-C	770	275	60	7165	6500	1500	2200	85
ComPAC 233 S-C	1110	368	230	11100	7000	1500	2500	86
ComPAC 233 L-C	1400	470	270	11900	7000	1500	2500	86

120 S operates at 1470 rpm

Manufacturer reserves the rights to change specifications without prior notice.



ChillPAC

Extremely compact packaged ammonia chillers based on reciprocating compressors, with a 100–1400 kW capacity range



ChillPAC ammonia-based chillers feature an ultra-compact format so narrow that they can even pass through a normal doorway. This is achieved by having an extra-compact shell-and-plate evaporator/condenser, oil separator and control system all built in and fully integrated into a unique vibration-resistant design.

This means ChillPAC units provide exceptional refrigeration capacity – taking full advantage of the many different models of ultra-reliable Sabroe reciprocating compressors – while only taking up a minimum of space. This makes ChillPAC units ideal in installations where space is limited, and where there are restrictions on the refrigerant charge used.

ChillPAC chillers are most cost-effective when fitted with a variable-speed drive (VSD) that makes it easy to deal with changing circumstances and different operating requirements.



Range

There are 20 different models in the standard ChillPAC range, with capacities ranging from 90 kW to 1398 kW.

Main benefits

- Fast installation – quick start-up
- High reliability – 100% factory-tested
- Minimised life cycle costs
- High safety standards – small refrigerant charge.

Options

- Variable-speed drive (VSD)
- Soft-starter or Y/D starter
- De-superheater
- Sub-cooler
- External condenser
- Control panel mounted separately
- S and L models: 1800 rpm at 60 Hz or VSD
- Customer-witnessed factory acceptance tests (FAT)
- Heater package for low-temperature heat pump operation
- Shunt solution for high-temperature difference.

Advantages

Factory-assembled, pre-tested packaged units based on Sabroe reciprocating compressors world-renowned for their reliability

Exceptionally compact design and fully integrated configuration results in less than half the footprint of bespoke chiller designs

Indirect cooling and uncomplicated flooded evaporating system, using natural ammonia (R717) only

Exceptional COP and outstanding part-load performance

Refrigerant charge 50% smaller than with conventional chillers, because of special condenser/evaporator design

Benefits

Easy pre-commissioning makes installation and running-in both faster and cheaper. Factory acceptance tests (FAT) available (as an option)

Major savings on both weight and space, resulting in lower installation costs. Much less need for expensive separate machinery rooms

Greater safety and outstanding reliability

Greater cooling effect from a smaller refrigerant charge, and optimum load structure over the entire capacity range

Higher output per unit kW/kg refrigerant, lower unit cost and lower installation costs.

ChillPAC water chillers (water: inlet +12°C, outlet +7°C)

Type	Cooling capacity kW	E-motor	R717 charge kg	Dry weight kg	Dimensions			Sound press. level *) dB(A)
					L mm	W mm	H mm	
ChillPAC 34	139*	27	13	2 000	2 900	1 000	2 000	70
ChillPAC 26	177*	33	14	2 050	2 900	1 000	2 000	71
ChillPAC 36	205*	40	14	2 100	2 900	1 000	2 000	70
ChillPAC 28	234*	45	15	2 150	2 900	1 000	2 000	73
ChillPAC 38	276*	55	16	2 350	2 900	1 000	2 000	74
ChillPAC 104 S-A	233	45	14	2 301	2 900	1 000	2 000	78
ChillPAC 104 L-A	294	55	15	2 410	2 900	1 000	2 000	79
ChillPAC 106 S-A	346	75	17	2 727	2 900	1 000	2 000	79
ChillPAC 104 E-A	357	75	17	2 652	2 900	1 000	2 000	79
ChillPAC 106 L-A	440	90	21	2 950	2 900	1 000	2 000	80
ChillPAC 108 S-A	464	90	22	3 060	2 900	1 000	2 000	80
ChillPAC 106 E-A	536	110	24	3 225	3 100	1 000	2 000	81
ChillPAC 108 L-A	588	110	26	3 526	3 100	1 000	2 000	82
ChillPAC 112 S-A	690	132	29	4 315	4 000	1 000	2 200	82
ChillPAC 108 E-A	715	132	30	3 880	3 300	1 000	2 000	82
ChillPAC 112 L-A	878	160	36	4 738	4 500	1 000	2 200	83
ChillPAC 116 S-A	921	200	37	5 044	4 500	1 000	2 200	83
ChillPAC 112 E-A	1 066	200	41	5 196	4 600	1 000	2 200	83
ChillPAC 116 L-A	1 167	250	45	5 556	4 700	1 000	2 200	83
ChillPAC 116 E-A	1 398	315	49	5 878	5 000	1 000	2 200	84

ChillPAC brine chillers (ethylene glycol 30%: inlet -4°C, outlet -8°C)

Type	Cooling capacity kW	E-motor	R717 charge kg	Dry weight kg	Dimensions			Sound press. level *) dB(A)
					L mm	W mm	H mm	
ChillPAC 26	90*	30	13	2 000	2 900	1 000	2 000	70
ChillPAC 36	105*	33	13	2 050	2 900	1 000	2 000	72
ChillPAC 28	119*	37	14	2 100	2 900	1 000	2 000	73
ChillPAC 38	139*	45	15	2 250	2 900	1 000	2 000	73
ChillPAC 104 S-C	116	37	13	2 253	2 700	1 000	2 000	78
ChillPAC 104 L-C	150	55	15	2 378	2 900	1 000	2 000	79
ChillPAC 106 S-C	172	55	15	2 505	2 900	1 000	2 000	79
ChillPAC 104 E-C	185	75	17	2 586	2 900	1 000	2 000	79
ChillPAC 106 L-C	222	75	18	2 701	2 900	1 000	2 000	80
ChillPAC 108 S-C	227	75	18	2 766	2 900	1 000	2 000	80
ChillPAC 106 E-C	272	90	20	2 866	2 900	1 000	2 000	80
ChillPAC 108 L-C	295	110	22	3 091	3 100	1 000	2 000	82
ChillPAC 112 S-C	339	110	24	3 696	3 800	1 000	2 200	82
ChillPAC 108 E-C	363	132	25	3 523	3 300	1 000	2 000	82
ChillPAC 112 L-C	440	160	29	4 290	4 200	1 000	2 200	83
ChillPAC 116 S-C	450	160	29	4 390	4 200	1 000	2 200	83
ChillPAC 112 E-C	544	200	35	4 733	4 300	1 000	2 200	83
ChillPAC 116 L-C	586	200	37	4 898	4 300	1 000	2 200	83
ChillPAC 116 E-C	718	250	43	5 322	4 300	1 000	2 200	83

Condenser: water inlet +30°C, outlet +35°C.

The above data are only valid for the stated temperatures and operating conditions. Capacities are nominal at 1500 rpm. * Capacities are nominal at 1800 rpm..

A = Air conditioning application (temperature above 0°C)

C = Chiller application (temperature below 0°C)

Sound pressure levels in free field, over reflecting plane and 10 m distance from the unit.

SABlight

Sabroe SABlight air-cooled chillers



Compact air-cooled chillers for outdoor installation, based on a screw compressor, with a 95–400 kW capacity range. The SABlight air-cooled chiller is a particularly compact design that uses V-coil condensers to substantially reduce the overall footprint resulting in a height of 2.9 m and a width of only 1.3 m. SABlight units provide a cost-effective alternative to traditional air conditioning, chilled rooms and industrial/process refrigeration. They are designed for quiet running and outdoor operation. SABlight uses a small propane refrigerant charge, providing an attractive, economical and environmentally responsible alternative to air-cooled chillers that use HFCs as refrigerant.



Standard equipment

- Control and monitoring system
- Variable-speed drive
- Hot-dip galvanised base frame
- Screw compressor
- Pre-charged with refrigerant.

Compliance

All SABlight air-cooled chillers are fully compliant with PED (CE marked and PED approved). Approval in accordance with other classification societies is available on request.

Options

- External communication via network and industrial-standard bus systems
- Evaporator heating elements for frost-proofing
- Epoxy coating of condenser surface
- Oil cooler
- Models operating with inlet temperatures below 0°C available on request
- Desuperheater
- Oil pump.

Advantages

Compact design with small footprint

Quiet while running. Available in both low and ultra-low noise versions

Variable-speed drive fitted to both compressor and fans, providing very high coefficient of performance (COP), even under part-load conditions

Designed for maximum safety, with very small natural refrigerant charge (propane R290)

Easy to mount, install and connect up

Straightforward, uncomplicated construction

Benefits

Easy to mount outdoors – no special machinery room required

Can be placed close to occupied buildings

Low power consumption, which means low operating costs

No expenditure on special safety precautions

Low installation costs and rapid commissioning

Low maintenance costs

Sabroe SABlight air-cooled chillers

Type	Cooling capacity kW	COP ESEER	R290 charge kg	Dry weight kg	Dimensions			Power consumption kW	Nominal load current A	Sound press. level dB(A)
					L mm	W mm	H mm			
SABlight A140-1	178	4.7	24	2 300	5 260	1 250	2 835	54	110	55
SABlight A140-2	174	4.6	24	2 300	5 260	1 250	2 835	51	115	45
SABlight A200-1	235	4.8	24	2 500	5 260	1 250	2 835	70	155	55
SABlight A200-2	232	4.6	32	3 000	6 660	1 250	2 835	69	160	45
SABlight A260-1	293	4.6	32	3 000	6 660	1 250	2 835	85	190	55
SABlight A260-2	288	4.6	40	3 300	8 060	1 250	2 835	85	190	45
SABlight A340-1	356	4.7	40	3 700	8 060	1 250	2 835	101	215	55
SABlight A340-2	341	4.6	48	4 200	9 460	1 250	2 915	102	220	45
SABlight A400-1	427	4.8	48	4 400	9 460	1 250	2 915	115	250	55
SABlight A400-2	413	4.6	56	4 800	10 860	1 250	2 915	122	250	45

Capacity data are based on water temperature 12/7°C, ambient temperature 30°C. Two or more units can be built together if larger capacities are required. ESEER = European seasonal energy efficiency ratio (Eurovent Institute, Europe). Fans and VSD are included in the power consumption. Sound pressure levels in free field, over reflecting plane and 10 m distance from the unit.



Manufacturer reserves the rights to change specifications without prior notice.



Sabroe Unisab III

Integrated systems controller for refrigeration compressors, chillers and heat pumps

Unisab III systems controllers are connectivity hubs that help make sure refrigeration installations have the best possible performance, maximum uptime and lowest possible operating costs.

These important control units are pre-equipped and pre-configured with the connectivity equipment and protocols necessary for monitoring and controlling a wide range of compressors, compressor packages, chillers and heat pumps – as well as using this data for fault-finding and analysis.

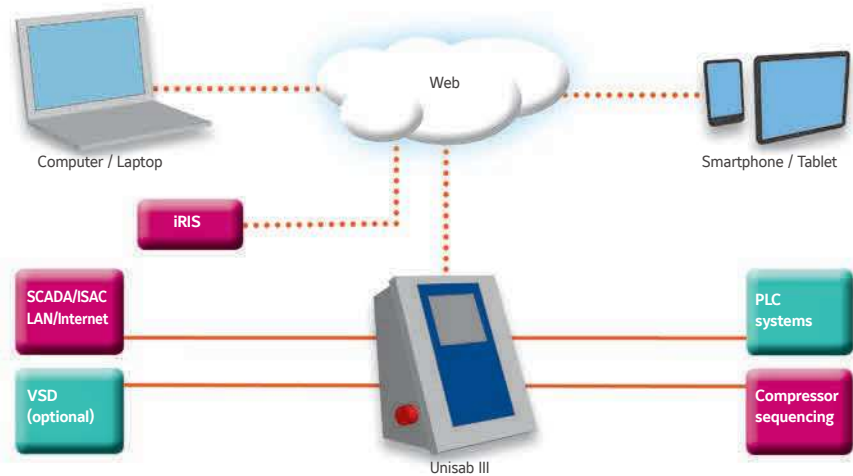

Sabroe chiller plant controller

Integrated solution for managing and monitoring the controls equipment in chiller plants



The Sabroe chiller plant controller is a compact, easy-to-install control panel that contains a pre-programmed PLC system and touch panel for monitoring and controlling a wide range of external equipment that is not part of the chiller itself, but that serves the chilled water distribution system as well as other key equipment in the chiller plant.

Sabroe Intelligent Remote Information Services (iRIS)

Intelligent reporting and documentation system for optimising plant performance

Intelligent Remote Information Services (iRIS) is a unique Sabroe software platform (managed by Johnson Controls) that registers, captures and collates performance data from all types of industrial refrigeration and thermal transfer equipment.

The iRIS system processes data such as:

- Load distribution and power consumption
- Performance patterns and fluctuations over time
- Statistics for shutdowns and alarms to reveal any irregularities in operation
- Comparisons and benchmarking between the different plants in a company, and operations in different countries.

The iRIS system is part of a complete service concept, working on the basis of information collected and structured by the iRIS server to form different reports and services. These are available by subscription, tailored to the requirements of each individual installation.

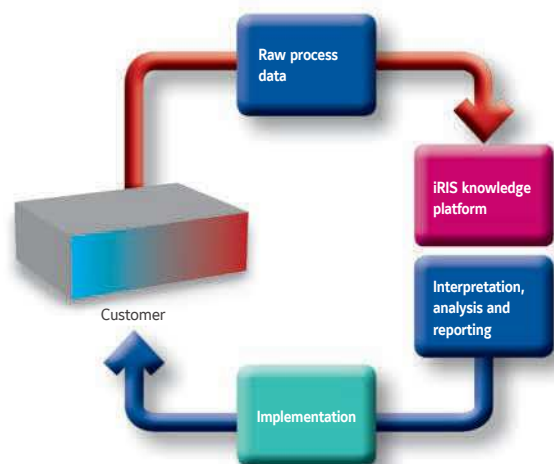

Metasys® Building Automation and Control Systems

Metasys® building management system from Johnson Controls ensures all of the building systems – comfort controls, lighting, fire safety, security and HVAC equipment – operate together in harmony. With an innovative, IT-based infrastructure, software and wireless capabilities, Metasys® is the one building management system that coordinates and organizes all the information logically to deliver it where and when needed, giving more control and easier access to information than any other system of its kind.

Previously a winner of the Frost & Sullivan North American BAS Market Leadership Award, Metasys now offers even more.

Ease of use

- Easy to configure and deploy
- No special training is required to use it
- The new Metasys UI is designed to enhance our customers' productivity and effectiveness. It allows users to navigate by space to view summaries, trends, and activities, emulating the way they work every day. The new user interface is also optimized for all devices, enabling our customers to work smarter from any device and any location.



More efficiency, less costs

- The Energy Essentials leverages the Metasys® Advanced Reporting System to take the existing data and present it in an organized and informative way, providing easy-to-configure, easy-to-use and actionable energy reports
- The improved Johnson Controls Central Plant Optimization™ 10 (CPO 10) helps facility managers operate their chiller plants more efficiently. CPO algorithms are used to operate and sequence plant equipment in an efficient and reliable manner, and to ensure that runtime, starts and stops are equalized across the individual plant components saving energy and improving reliability in the facility.

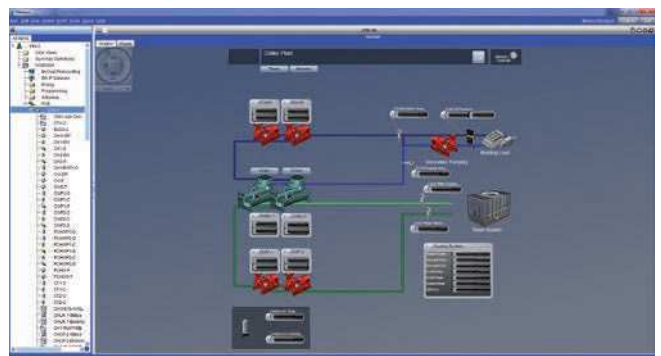

Single platform communication

- Enhanced, single platform interface of thousands of different hardwired and wireless systems, devices and equipment.
- Even more control options and better information access by users, thanks to:
 - Field Equipment Controllers redesigning
 - Terminal Equipment Controller updates and improvements
 - Added wireless and network sensors
 - Enhanced software and firmware



Wireless Capabilities

- Increased control flexibility, streamlines retrofits and faster download times, thanks to the latest wireless technologies that Metasys® incorporates into more devices.
- At system's user interface, network automation, field controller or room sensing levels, Wireless Building Technologies from Johnson Controls always result in increased application flexibility and cost effectiveness.



Security features

- Metasys® now incorporates P2000 Security Management System, whose software and network controllers ensure the safety of employees and security of company assets.
- P2000 open integration platform, designed for interoperability with a variety of security subsystems including access control, alarm & intrusion detection, video surveillance, visitor management.

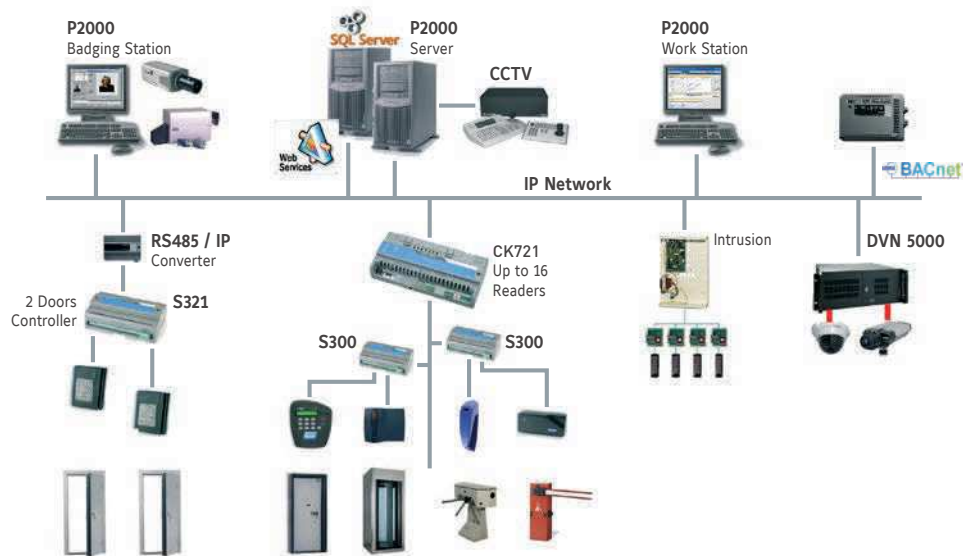

CE Manufacturer reserves the rights to change specifications without prior notice.

Metasys® Energy Dashboard

Metasys® Energy Dashboard is a software solution designed specifically for addressing the needs of energy management in all sort of facilities. It enables dynamic visualization and reporting through an intuitive, rich and easy-to-use interface.

Metasys® Energy Dashboard has been conceived using the combination of Johnson Controls global expertise in the fields of building automation, HVACR and energy management projects.

The solution is comprises four main modules allowing a customer to acquire only those that better fit its need. These are: Energy, Equipment, Tenant Billing and Tenant Portal.

Key features include:

- Intuitive, flexible user interface – fully configurable layout
- Sensible reporting options that come as in-built templates – can start actionable analysis from day 0
- Contextualized, modular structure – catering to the specific needs of respective users
- Caters to energy analysis and reporting, equipment performance monitoring, tenant billing and after hour schedule override needs of the building occupants
- Multiple database sources / site can be integrated simultaneously
- Web based tool - requires no additional hardware, minimal additional software
- Multi-lingual support – English, Dutch, French, Italian, Japanese, Spanish, simplified Chinese

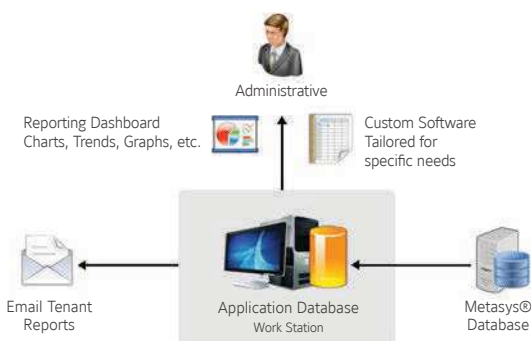
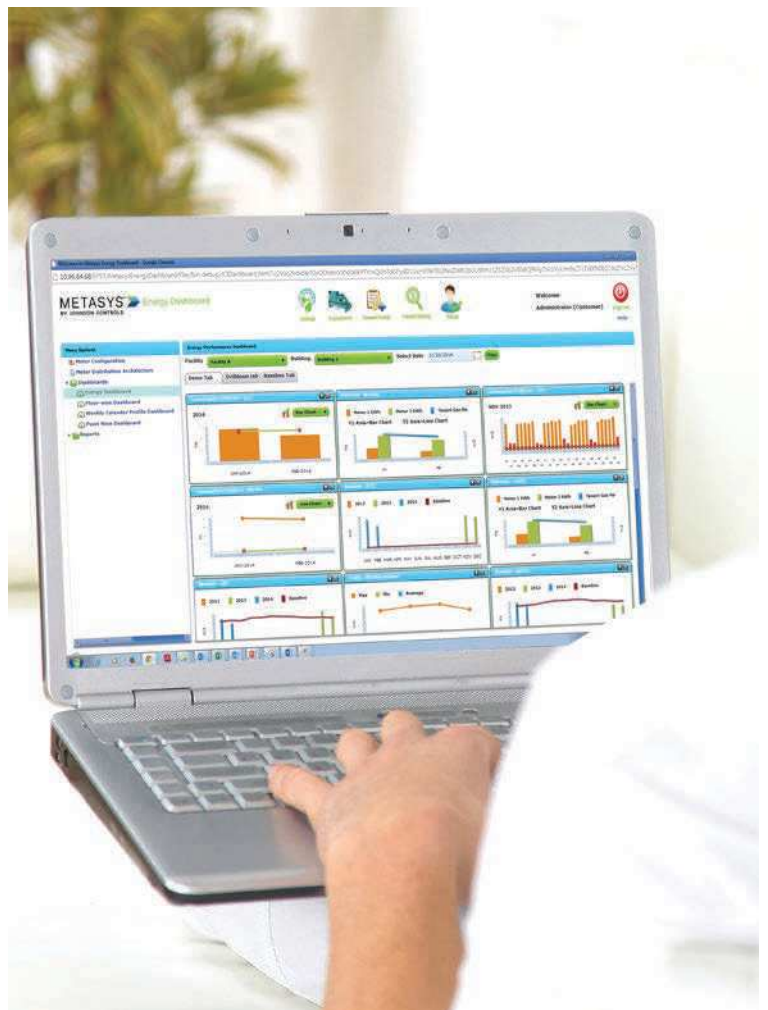

Johnson Control's eCatalog

Johnson Control's eCatalog, also known as the "Virtual Branch", is not only an extensive database of product information but also a point of entry into our organization.

Within the eCatalog you are connected to the cloud and hence stay up-to-date on all new product launches, product selection tool releases and updates, technical documents, eLearning modules and much more. You will reach our products in 3-clicks or less through the use of a powerful search engine and a very easy-to-browse navigation menu. You can also view the purchase prices online for many of our products and check the availability of stocked items at a glance. Also, rest assured that access to our network of Sales Representatives and Technical Support teams is directly available for your use.

**Call your Sales Representative
and request access now.**

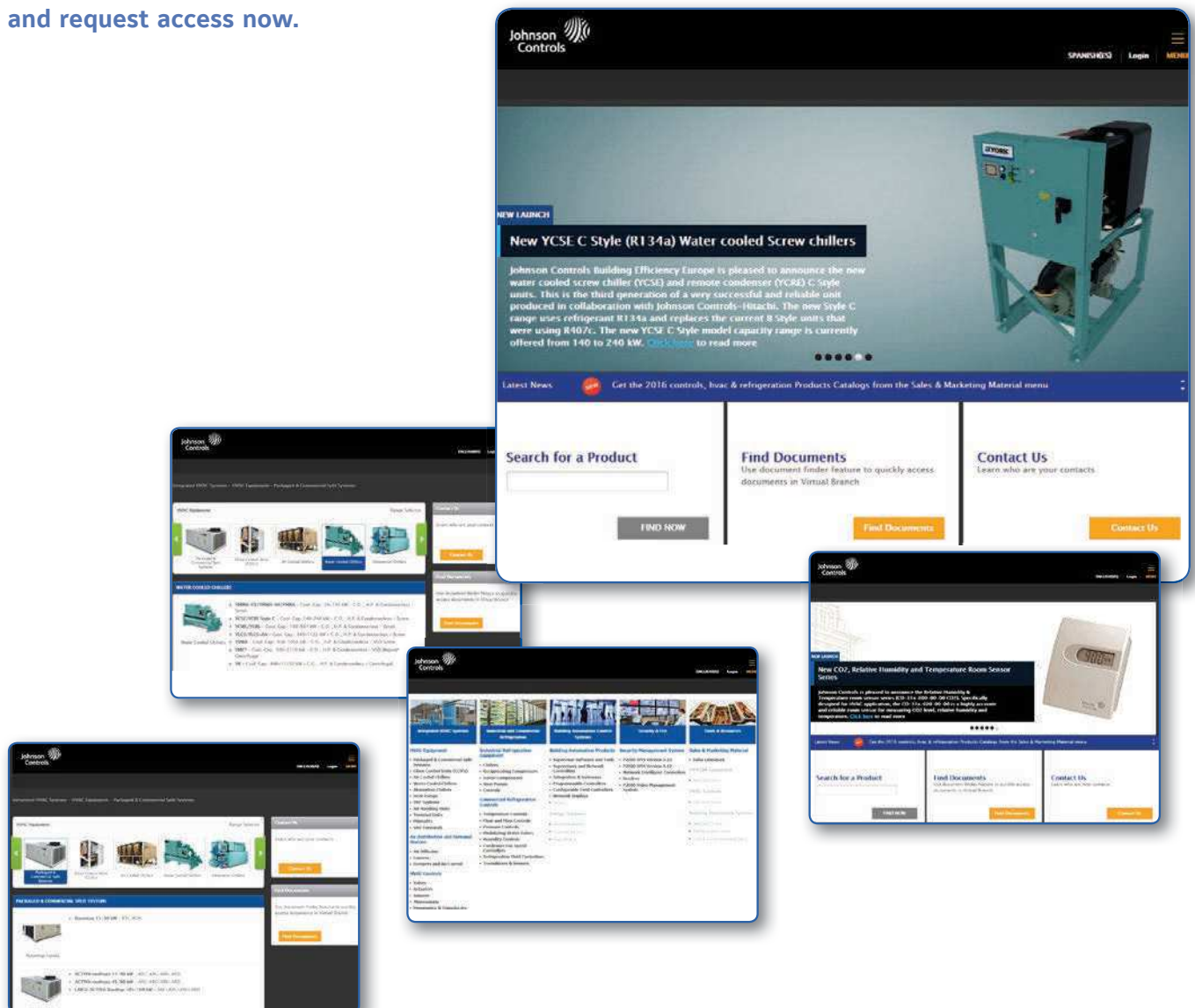



About Johnson Controls

Johnson Controls delivers products, services and solutions that increase energy efficiency and lower operating costs in buildings for more than one million customers.

Operating from 500 branch offices in more than 150 countries, the company is a leading provider of equipment, controls and services for heating, ventilating, air-conditioning, refrigeration and security systems. Johnson Controls is involved in more than 500 renewable energy projects including solar, wind and geothermal technologies.

Its solutions have reduced carbon dioxide emissions by 13.6 million metric tons and generated savings of \$7.5 billion since 2000. Many of the world's largest companies rely on Johnson Controls to manage 1.5 billion square feet of their commercial real estate.

