

BUSH HOG®

TD 1500/1700

**Tri-Deck Finishing Mower
Operator's Manual**



BUSH HOG®
Performance You Can Count On™

ASSEMBLY ● OPERATION ● MAINTENANCE

CONGRATULATIONS!

You have invested in the best implement of its type on the market today.

The care you give your Bush Hog implement will greatly determine your satisfaction with its performance and its service life. We urge a careful study of this manual to provide you with a thorough understanding of your new implement before operating, as well as suggestions for operation and maintenance.

If your manual should become lost or destroyed, Bush Hog will be glad to provide you with a new copy. Order from Bush Hog, 2501 Griffin Ave., Selma, Alabama 36703. Most of our manuals can also be downloaded from our website at www.bushhog.com.

As an authorized Bush Hog dealer, we stock genuine Bush Hog parts which are manufactured with the same precision and skill as our original equipment. Our trained service personnel are well informed on methods required to service Bush Hog equipment, and are ready and able to help you.

Should you require additional information or assistance, please contact us.

YOUR AUTHORIZED
BUSH HOG DEALER

BECAUSE BUSH HOG MAINTAINS AN ONGOING PROGRAM OF PRODUCT IMPROVEMENT, WE RESERVE THE RIGHT TO MAKE IMPROVEMENTS IN DESIGN OR CHANGES IN SPECIFICATIONS WITHOUT INCURRING ANY OBLIGATION TO INSTALL THEM ON UNITS PREVIOUSLY SOLD.

BECAUSE OF THE POSSIBILITY THAT SOME PHOTOGRAPHS IN THIS MANUAL WERE TAKEN OF PROTOTYPE MODELS, PRODUCTION MODELS MAY VARY IN SOME DETAIL. IN ADDITION, SOME PHOTOGRAPHS MAY SHOW SHIELDS REMOVED FOR PURPOSES OF CLARITY. **NEVER OPERATE** THIS IMPLEMENT WITHOUT ALL SHIELDS IN PLACE.

TD 1500/1700

Tri-Deck Finishing Mower

TABLE OF CONTENTS

| SECTION/PARA | PAGE | SECTION/PARA | PAGE |
|-------------------------------------|------|----------------------------------|------|
| Warranty | 2 | 3-3 Operation | 8 |
| Dealer Preparation Check List | 3 | 3-4 Transporting..... | 9 |
| Safety Precautions..... | 4 | IV.MAINTENANCE | 9 |
| Federal Laws and Regulations | 5 | 4-1 Maintenance Check List | 9 |
| I. INTRODUCTION & DESCRIPTION | 6 | 4-2 Lubrication | 10 |
| 1-1 Introduction | 6 | 4-3 Belt Adjustment | 11 |
| 1-2 Description..... | 6 | 4-4 Belt Replacement..... | 11 |
| II. PREPARATION FOR USE | 7 | 4-5 Blade Replacement | 11 |
| 2-1 Attaching To Tractor | 7 | 4-6 Troubleshooting | 12 |
| III. OPERATING INSTRUCTIONS..... | 8 | Safety Decals..... | 13 |
| 3-1 General Safety..... | 8 | Torque Specifications..... | 16 |
| 3-2 Cutting Height Adjustment..... | 8 | | |

RETAIL CUSTOMER'S RESPONSIBILITY UNDER THE BUSH HOG WARRANTY

It is the Retail Customer and/or Operator's responsibility to read the Operator's Manual, to operate, lubricate, maintain and store the product in accordance with all instructions and safety procedures. Failure of the operator to read the Operator's Manual is a misuse of this equipment.

It is the Retail Customer and/or Operator's responsibility to inspect the product and to have any part(s) repaired or replaced when continued operation would cause damage or excessive wear to other parts or cause a safety hazard.

It is the Retail Customer's responsibility to deliver the product to the authorized Bush Hog Dealer, from whom he purchased it, for service or replacement of defective parts which are covered by warranty. Repairs to be submitted for warranty consideration must be made within forty-five (45) days of failure.

It is the Retail Customer's responsibility for any cost incurred by the Dealer for traveling to or hauling of the product for the purpose of performing a warranty obligation or inspection.

UNDERSTANDING SIGNAL WORDS



DANGER: Red Background, White Text - Indicates an imminently hazardous situation which, if not avoided, will result in death or serious injury. This signal word is to be limited to the most extreme situations.



WARNING: Orange Background, Black Text -Indicates a potentially hazardous situation which, if not avoided, could result in death or serious injury.



CAUTION: Yellow Background, Black Text -Indicates a potentially hazardous situation which, if not avoided, may result in minor or moderate injury. It may also be used to alert against unsafe practices.



LIMITED WARRANTY



Bush Hog warrants to the original purchaser of any new Bush Hog equipment, purchased from an authorized Bush Hog dealer, that the equipment be free from defects in material and workmanship for a period of one (1) year for non-commercial, state and municipalities' use and ninety (90) days for commercial use from date of retail sale. Models TD-1500 & TD 1700 gearboxes are covered by a five (5) year limited warranty period. The obligation of Bush Hog to the purchaser under this warranty is limited to the repair or replacement of defective parts.

Replacement or repair parts installed in the equipment covered by this limited warranty are warranted for ninety (90) days from the date of purchase of such part or to the expiration of the applicable new equipment warranty period, whichever occurs later. Warranted parts shall be provided at no cost to the user at an authorized Bush Hog dealer during regular working hours. Bush Hog reserves the right to inspect any equipment or parts which are claimed to have been defective in material or workmanship.

DISCLAIMER OF IMPLIED WARRANTIES & CONSEQUENTIAL DAMAGES

Bush Hog's obligation under this limited warranty, to the extent allowed by law, is in lieu of all warranties, implied or expressed, **INCLUDING IMPLIED WARRANTIES OF MERCHANTABILITY AND FITNESS FOR A PARTICULAR PURPOSE** and any liability for incidental and consequential damages with respect to the sale or use of the items warranted. Such incidental and consequential damages shall include but not be limited to: transportation charges other than normal freight charges; cost of installation other than cost approved by Bush Hog; duty; taxes; charges for normal service or adjustment; loss of crops or any other loss of income; rental of substitute equipment, expenses due to loss, damage, detention or delay in the delivery of equipment or parts resulting from acts beyond the control of Bush Hog.

THIS LIMITED WARRANTY SHALL NOT APPLY:

1. To vendor items which carry their own warranties, such as engines, tires, and tubes.
2. If the unit has been subjected to misapplication, abuse, misuse, negligence, fire or other accident.
3. If parts not made or supplied by Bush Hog have been used in connection with the unit, if, in the sole judgement of Bush Hog such use affects its performance, stability or reliability.
4. If the unit has been altered or repaired outside of an authorized Bush Hog dealership in a manner which, in the sole judgement of Bush Hog, affects its performance, stability or reliability.
5. To normal maintenance service and normal replacement items such as gearbox lubricant, hydraulic fluid, worn blades, or to normal deterioration of such things as belts and exterior finish due to use or exposure.
6. To expendable or wear items such as teeth, chains, sprockets, belts, springs and any other items that in the company's sole judgement is a wear item.

NO EMPLOYEE OR REPRESENTATIVE OF BUSH HOG IS AUTHORIZED TO CHANGE THIS LIMITED WARRANTY IN ANY WAY OR GRANT ANY OTHER WARRANTY UNLESS SUCH CHANGE IS MADE IN WRITING AND SIGNED BY BUSH HOG'S SERVICE MANAGER, 2501 GRIFFIN AVE., SELMA, ALABAMA 36703.



Record the model number, serial number and date purchased. This information will be helpful to your dealer if parts or service are required.

MODEL NUMBER _____

SERIAL NUMBER _____

MAKE CERTAIN THE WARRANTY INFORMATION HAS BEEN FILED ONLINE WITH BUSH HOG SELMA, ALABAMA

DATE OF RETAIL SALE _____

DEALER PREPARATION CHECK LIST

Tri-Deck Finishing Mowers

BEFORE DELIVERING MACHINE — The following check list should be completed.
Use the Operator's Manual as a guide.

- 1. Assembled completed.
- 2. Gearboxes filled with oil.
- 3. All fittings lubricated.
- 4. All shields in place and in good condition.
- 5. All fasteners torqued to specifications given in Torque Chart
- 6. All decals in place and readable. (See decal page.)
- 7. Overall condition good (i.e. paint, welds)
- 8. Operators manual has been delivered to owner and he has been instructed on the safe and proper use of the cutter.
- 9. Warranty has been registered online with Bush Hog, Selma Alabama.

WARNING

For Non-Agricultural use, OSHA, ASAE, SAE and ANSI standards require the use of Chain Guards or other protective guards at all times. Bush Hog strongly recommends the use of such guards for Agricultural uses as well, to reduce the risk of property damage, serious bodily injury or even death from objects thrown out by or from contact with the cutting blades.

Dealer's
Signature _____

Purchaser's
Signature _____

THIS CHECKLIST TO REMAIN IN OWNER'S MANUAL
It is the responsibility of the dealer to complete the procedures listed above before delivery of this implement to the customer.

IMPORTANT SAFETY PRECAUTIONS

This symbol is used to call attention to safety precautions that should be followed by the operator to avoid accidents. When you see this symbol, carefully read the message that follows and heed its advice. Failure to comply with safety precautions could result in serious bodily injury.



In addition to the design and configuration of equipment, hazard control and accident prevention are dependent upon the awareness, concern, prudence and proper training of personnel in the operation, transport, maintenance and storage of equipment. Lack of attention to safety can result in accident, personal injury, reduction of efficiency and worst of all—loss of life. Watch for safety hazards and correct deficiencies promptly. Use the following safety precautions as a general guide to safe operations when using this machine. Additional safety precautions are used throughout this manual for specific operating and maintenance procedures. Read this manual and review the safety precautions often until you know the limitations.

1. Read the Operator's Manual. Failure to read the Operator's Manual is considered a misuse of this equipment.
2. Become familiar with all the machine's controls and all the caution, warning and danger decals affixed to the machine before attempting to start or operate.
3. Before starting or operating the machine, make a walk around inspection and check for obvious defects such as loose mounting bolts and damaged components. Correct any deficiency before starting.
4. Do not allow children to operate the cutter. Do not allow adults to operate it without proper instruction.
5. Do not carry passengers.
6. Keep the area of operation clear of all persons, particularly small children and pets. The operator should cease mowing whenever anyone comes within the operating area.
7. Clear the work area of objects which might be picked up and thrown.
8. Use a piece of cardboard or wood rather than hands to search for hydraulic leaks. Escaping hydraulic oil under pressure can penetrate skin. If fluid is injected into the skin, it must be surgically removed within a few hours by a doctor familiar with this form of injury or gangrene may result.
9. Do not operate without all guards and shields in place and in good condition.
10. Lower implement to ground, stop tractor engine, apply parking brake, and allow blades to completely stop before leaving the tractor.
11. Keep hands and feet away from blades.
12. This cutter is not to be operated along highways or in any area where people may be present unless all sides of the unit are enclosed by permanent bands, safety chains or other factory approved safety shields that are in good repair.
13. Wear personal protective equipment such as, but not limited to, protection for eyes, ears, feet, hands and head when operating or repairing the equipment. Do not wear loose clothing or jewelry that may catch on equipment moving parts.
14. When performing adjustments or maintenance on the cutter, first lower it to the ground or block it securely at a workable height.
15. Never stand between tractor and cutter while tractor is being backed to the cutter hitch.
16. Reduce speed when transporting cutter to avoid bouncing and momentary loss of steering.
17. Use tractor flashing warning lights, day or night, when transporting cutter on road or highways unless prohibited by law.
18. It is recommended that tractor be equipped with Rollover Protective System (ROPS) and seat belt be used in all mowing operations.

IMPORTANT FEDERAL LAWS AND REGULATIONS* CONCERNING EMPLOYERS, EMPLOYEES AND OPERATIONS.

*(This section is intended to explain in broad terms the concept and effect of the following federal laws and regulations. It is not intended as a legal interpretation of the laws and should not be considered as such).

U.S. Public Law 91-596 (The Williams-Steiger Occupational and Health Act of 1970) OSHA

This Act Seeks:

"...to assure so far as possible every working man and woman in the nation safe and healthful working conditions and to preserve our human resources..."

DUTIES

Sec. 5 (a) Each employer—

- (1) shall furnish to each of his employees employment and a place of employment which are free from recognized hazards that are causing or are likely to cause death or serious physical harm to his employees;
- (2) shall comply with occupational safety and health standards promulgated under this Act.
 - (b) Each employee shall comply with occupational safety and health standards and all rules, regulations and orders issued pursuant to this Act which are applicable to his own actions and conduct.

OSHA Regulations

Current OSHA regulations state in part: "At the time of initial assignment and at least annually thereafter, the employer shall instruct every employee in the safe operation and servicing of all equipment with which the employee is, or will be involved." These will include (but are not limited to) instructions to:

Keep all guards in place when the machine is in operation;

Permit no riders on equipment;

Stop engine, disconnect the power source, and wait for all machine movement to stop before servicing, adjusting, cleaning or unclogging the equipment, except where the machine must be running to be properly serviced or maintained, in which case the employer shall instruct employees as to all steps and procedures which are necessary to safely service or maintain the equipment.

Make sure everyone is clear of machinery before starting the engine, engaging power, or operating the machine.

EMPLOYEE TRACTOR OPERATING INSTRUCTIONS:

1. Securely fasten your seat belt if the tractor has a ROPS.
2. Where possible, avoid operating the tractor near ditches, embankments, and holes.
3. Reduce speed when turning, crossing slopes, and on rough, slick, or muddy surfaces.
4. Stay off slopes too steep for safe operation.
5. Watch where you are going, especially at row ends, on roads, and around trees.
6. Do not permit others to ride.
7. Operate the tractor smoothly - no jerky turns, starts, or stops.
8. Hitch only to the drawbar and hitch points recommended by tractor manufacturers.
9. When tractor is stopped, set brakes securely and use park lock if available.

Child Labor Under 16 Years Old

Some regulations specify that no one under the age of 16 may operate power machinery. It is your responsibility to know what these regulations are in your own area or situation. (Refer to U.S. Dept. of Labor, Employment Standard Administration, Wage & Home Division, Child Labor Bulletin #102.)

SECTION I INTRODUCTION AND DESCRIPTION

1-1 INTRODUCTION

We are pleased to have you as a Bush Hog customer. Your TD Series Finishing Mower has been carefully designed to give maximum service with minimum down time. This manual is provided to give you the necessary operating and maintenance instructions for keeping your mower in top operating condition. Please read this manual thoroughly. Understand what each control is for and how to use it. Observe all safety precautions decaled on the machine and noted throughout the manual for safe operation of implement. If any assistance or additional information is needed, contact your authorized Bush Hog dealer.

NOTE

All references made to right, left, front, rear, top or bottom are as viewed facing the direction of travel with implement properly attached to tractor.

1-2 DESCRIPTION

The TD Series Finishing Mower, Figure 1-1, is designed for sod growers, golf courses, land owners, municipalities, and recreational areas where a high quality of cut on turf grasses is required.

Uplift blades form a suction during operation to lift the grass before cutting it. The caster wheel arrangement along with the flexible, floating deck attachment and the standard front mounted rollers, all work together to give an even cut and minimize scalping.

NOTE: The rear wheels on the two wing mower decks and the front wheels on the rear mower deck are rigidly mounted and are not designed to caster.

Power from the tractor is transmitted through a telescoping driveline to a divider gearbox, then to 90° gearboxes on each mower deck. It is then passed to the spindle housings by single, B-section Kevlar reinforced belts. Drivetrain protection is provided by belt slippage.

Figure 1-1

TD-1500 TRI-DECK FINISHING MOWER



Table 1-1 Technical Specifications

| Specifications | TD-1500 | TD-1700 |
|-----------------------|---|---|
| Cutting Width | 15' | 17' |
| Transport Width | 95-1/2" | 95-1/2" |
| Cutting Height | 1-1/2" - 4-1/2" | 1-1/2" - 4-1/2" |
| Weight | 2752 lbs. (Approx.) | 2855 lbs. (Approx.) |
| Blade Tip Speed (FPM) | 15,613 FPM | 15,613 FPM |
| Required Tractor HP | 40 HP (Min.) | 45 HP (Min.) |
| Wing Flex | 30° Up & 10° Down | 30° Up & 10° Down |
| Belts | "B" Size/Kevlar | "B" Size/Kevlar |
| Driveline Size | Cat. IV 80° CV (Main), Cat. III (Wing) | Cat. IV 80° CV (Main), Cat. III (Wing) |

SECTION II PREPARATION FOR USE

2-1 ATTACHING TO TRACTOR

IMPORTANT
(540 RPM only)

The minimum required PTO horsepower is 40HP for the TD-1500 and 45HP for the TD-1700.

⚠ WARNING

NEVER STAND BETWEEN TRACTOR AND MOWER WHILE TRACTOR IS BEING BACKED TO HITCH.

A. Adjust tractor drawbar length to dimension shown in Figure 2-1. Incorrect drawbar length will change angle of driveline causing possible damage to constant velocity joint. See tractor operator's manual for drawbar adjustment procedure.

Figure 2-1 Tractor Drawbar Adjustment

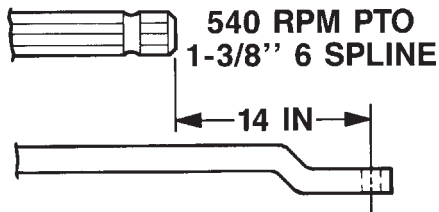

⚠ DANGER

• PTO ADAPTERS SHOULD NOT BE USED WITH ANY BUSH HOG EQUIPMENT

- The PTO adapter length will cause an unshielded shaft area between the tractor master shield and the driveline shield.
- Contact with and entanglement in the unshielded rotating PTO adaptor area can cause serious injury or death.
- The use of a PTO adapter can cause equipment overspeed, driveline failures and damage to tractor and implement.



B. Attach jackstand to tongue of cutter. Extend jackstand to support weight of tongue.

C. Connect clevis hitch to tractor drawbar using a 1 inch (25mm) diameter approved pin with lynch pin retainer or equivalent.

D. Adjust clevis height as necessary to level tongue. (Figure 2-2)

Figure 2-2 Constant Velocity U-Joint

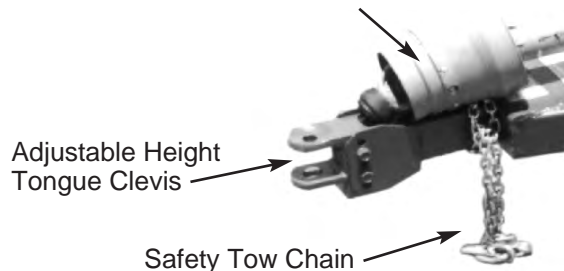

E. Route hydraulic hose and transport lock rope through hose holder rod. Connect hydraulic hose to tractor remote quick couplers. Make sure hydraulic line is not twisted or kinked.

F. Route control ropes to convenient location and fasten to tractor. Be sure excess slack is removed from the ropes to avoid entanglement with tractor tires or other moving parts. Make sure latch locking pins are in the stored positions so that latches can be released by pulling the ropes. (Refer to Figures 3-3 and 3-4)

G. Attach driveline to tractor. Pull on each driveline section to be sure that yoke locks into place.

H. Securely attach tow chain to tractor.

⚠ WARNING

USE A PIECE OF CARDBOARD OR WOOD RATHER THAN HANDS AND WEAR EYE PROTECTION WHEN SEARCHING FOR HYDRAULIC LEAKS. ESCAPING HYDRAULIC OIL UNDER PRESSURE CAN PENETRATE SKIN. IF OIL IS INJECTED INTO SKIN, IT MUST BE SURGICALLY REMOVED WITHIN A FEW HOURS OR GANGRENE MAY RESULT.

SECTION III OPERATING INSTRUCTIONS

3-1 GENERAL SAFETY

Only qualified people familiar with this operator's manual and tractor operator's manual should operate this machine. Operator should wear hard hat, safety glasses and safety shoes. The operator should read, understand and practice all safety messages shown on the caution, warning and danger decals affixed to the mower to avoid serious injury or death. It is recommended that tractor be equipped with Rollover Protective System (ROPS) and a seat belt be used. Before beginning operation, clear work area of any objects that may be picked up and thrown. Check for ditches, stumps, holes or other obstacles that could upset tractor or damage mower. **Never engage PTO with wings folded and never fold wings with PTO engaged.** Always lower mower to ground and allow blades to come to a complete stop, set parking brake and turn off tractor engine before leaving tractor operator's seat.

3-2 CUTTING HEIGHT ADJUSTMENT

The mower should be operated at the highest position that will give desired cutting results. This will help prevent blades from striking the ground, reducing blade wear and undue strain on the machine.

A. Raise mower off ground enough to remove caster. **SECURELY BLOCK MOWER IN POSITION** before working underneath.

WARNING

THE MOWER CAN FALL FROM HYDRAULIC SYSTEM FAILURE. TO AVOID SERIOUS INJURY OR DEATH, SECURELY SUPPORT MOWER BEFORE WORKING UNDERNEATH.

B. Remove pin securing caster stem to caster arm. (Figure 3-1). Remove caster stem from caster arm.

C. Place amount of spacers on caster stem to give desired cutting height. With no spacers on the bottom, a 1-1/2" cutting height is given.

D. Reinstall caster stem into caster arm. Place remaining spacers on caster stem above caster arm and install pin to retain.

E. Repeat operation for all caster wheels. Make certain all wheels are adjusted to the same height.

3-3 OPERATION

A. Perform BEFORE EACH USE maintenance list in paragraph 4-1.

B. Start tractor. Lower cutter until it is supported by caster wheels.

DANGER

STAY CLEAR OF ROTATING DRIVELINE. DO NOT OPERATE WITHOUT DRIVELINE SHIELDS IN PLACE AND IN GOOD CONDITION. FAILURE TO HEED THESE WARNINGS MAY RESULT IN PERSONAL INJURY OR DEATH.

Figure 3-1 Cutting Height Adjustment

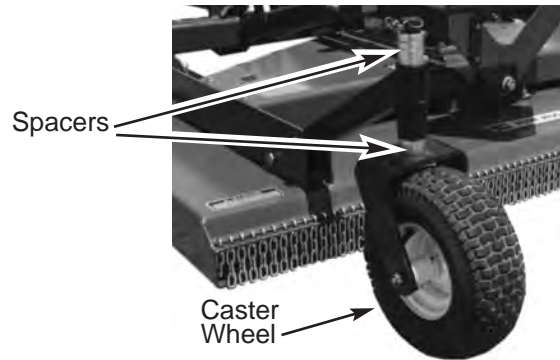

DANGER

STAND CLEAR OF ROTATING CUTTER BLADES UNTIL ALL MOTION HAS STOPPED. TO AVOID ACCIDENTAL FALL AND POSSIBLE INJURY FROM CUTTER, IT IS RECOMMENDED THAT TRACTOR BE EQUIPPED WITH ROLLOVER PROTECTIVE SYSTEM AND THAT A SEAT BELT BE USED FOR ALL OPERATIONS.

C. With tractor at idle speed, engage PTO drive. Advance throttle to 540 PTO rpm.

D. Place tractor in low gear and begin cutting. Tractor forward speed should be controlled by gear selection, not engine speed. For maximum cutting efficiency, forward speed should allow mower to maintain a constant maximum blade speed.

If tractor engine or cutter stalls, do not slip tractor clutch to allow engine to retain speed as this will exert undue strain on the implement drivetrain. When stalling occurs, disengage PTO drive, move to a cut area, set tractor throttle to idle, then re-engage PTO drive.

When mowing across slopes, yawing or skewing may occur as the implement slips sideways. This condition may cause streaking if there is insufficient overlap between the cutting swaths. To correct this situation, the outer mower decks may be moved in an additional 6" to increase overlap. NOTE: Initial distance from the end of the tube frame to edge of the U-bolt should be 8-1/8" on the 15' model and 2-1/8" on the 17' model. (Figure 3-2)

Figure 3-2 Loosen U-Bolts to slide deck on frame.

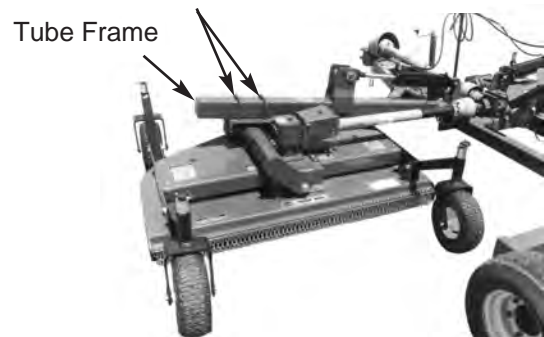

3-4 TRANSPORTING

Turn off PTO drive and fully raise mower decks until they latch into transport position. Install pins into the transport lock position. (Figures 3-3 & 3-4) When

Figure 3-3 Center Unit Transport Latch



Transport Lock Hole Pin In "Working" Position

implement is transported on road or highway, day or night, use tractor flashing warning lights unless prohibited by law. A slow moving vehicle (SMV) sign must be visible from the rear by approaching vehicles.

Figure 3-4 Wing Unit Transport Latches

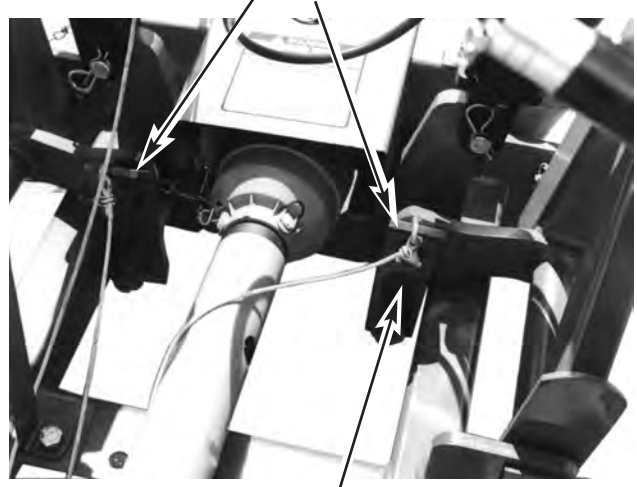

Insert Hair Pin Through Lug To Lock For Transport

SECTION IV MAINTENANCE

4-1 MAINTENANCE CHECK LIST

Perform scheduled maintenance as outlined below. Lower implement to ground, turn off tractor, and set parking brake before doing maintenance inspections or work. Some checks may require raising machine off ground and supporting with blocks. All bolts should be torqued as indicated in torque chart on page 16 unless otherwise indicated.

WARNING

THE CUTTER CAN FALL FROM HYDRAULIC SYSTEM FAILURE. TO AVOID SERIOUS INJURY OR DEATH, SECURELY SUPPORT CUTTER BEFORE WORKING UNDERNEATH.

BEFORE EACH USE.

1. Check tractor tire air pressure. Refer to tractor operator's manual. Mower transport tire pressure should be 22 psi; caster tire pressure should be 40 psi.
2. Check blades and spindles to be sure that no foreign objects such as wire or steel strapping bands are wrapped around them.
3. Check blade bolts for tightness. Tighten to 76 ft./lbs.
4. Inspect blades for wear. Replace if necessary per paragraph 4-5. Use only genuine Bush Hog replacement parts. If it is necessary to sharpen the blades, remove the blades from the spindles before

sharpening. DO NOT sharpen blades while still attached to mower.

5. Make certain all shields are in place and in good condition. Repair or replace any missing or damaged shields.
6. Inspect wheel(s) for wear, damage or foreign objects. Repair or replace if necessary.
7. Perform BEFORE EACH USE lubrication per paragraph 4-2.
8. During operation, listen for abnormal sounds which might indicate loose parts, damaged bearings, or other damage. Correct any deficiency before continuing operation.

AFTER EACH USE

1. Clean all debris from machine especially underside of deck, underneath belt shield and off safety decals. Replace any missing or illegible decals.
2. Inspect cutter for worn or damaged components. Repair or replace before next use. Any replacement components installed during repair shall include the components' current safety decals specified by the manufacturer to be affixed to the component.
3. Store cutter in a dry place.
40 HOURS
1. Check belt for proper tension. Refer to paragraph 4-3.

4-2 LUBRICATION (Figures 4-1A, B & C)

NOTE

The multi-purpose grease referenced in this section is an NLGI Grade 2 type grease.

BEFORE EACH USE

1. Driveline Universal Joints - Apply multi-purpose grease with grease gun.
2. Driveline Guard - Apply 2-3 shots of multi-purpose grease with grease gun to plastic fitting.
3. Wheels - Apply multi-purpose grease with grease gun.
4. Caster Pivot - Apply multi-purpose grease with grease gun.
5. Constant Velocity (CV) Joint - Position CV joint as straight as possible to be sure grease will penetrate to ball joint. Lubricate the central body with a minimum of 30 shots of grease every 8 hours. Lubricate telescoping members with 10 shots every 8 hours and clean telescoping members every 40 hours and completely coat with grease.

6. Gearboxes - Add EP80W-90 gear oil, if necessary, to bring oil level to check plug.

20 HOURS

7. Driveline - Disconnect PTO driveline, pull the two sections apart, apply thin coat of multi-purpose grease to outside of inner (male) section. Reassemble sections and install. Pull each section to be sure driveline and shields are securely connected. Make certain PTO shielding is in good condition.

40 HOURS

8. Spindle Assembly - Apply multi-purpose grease with grease gun until grease purges out top seal. Grease fittings for spindles should be accessed by removing the plastic plugs in the shields. After completing lubrication, replace plastic plugs.

END OF SEASON

9. Transport Wheel Bearings - Pack transport wheel bearings with grease at end of each mowing season.

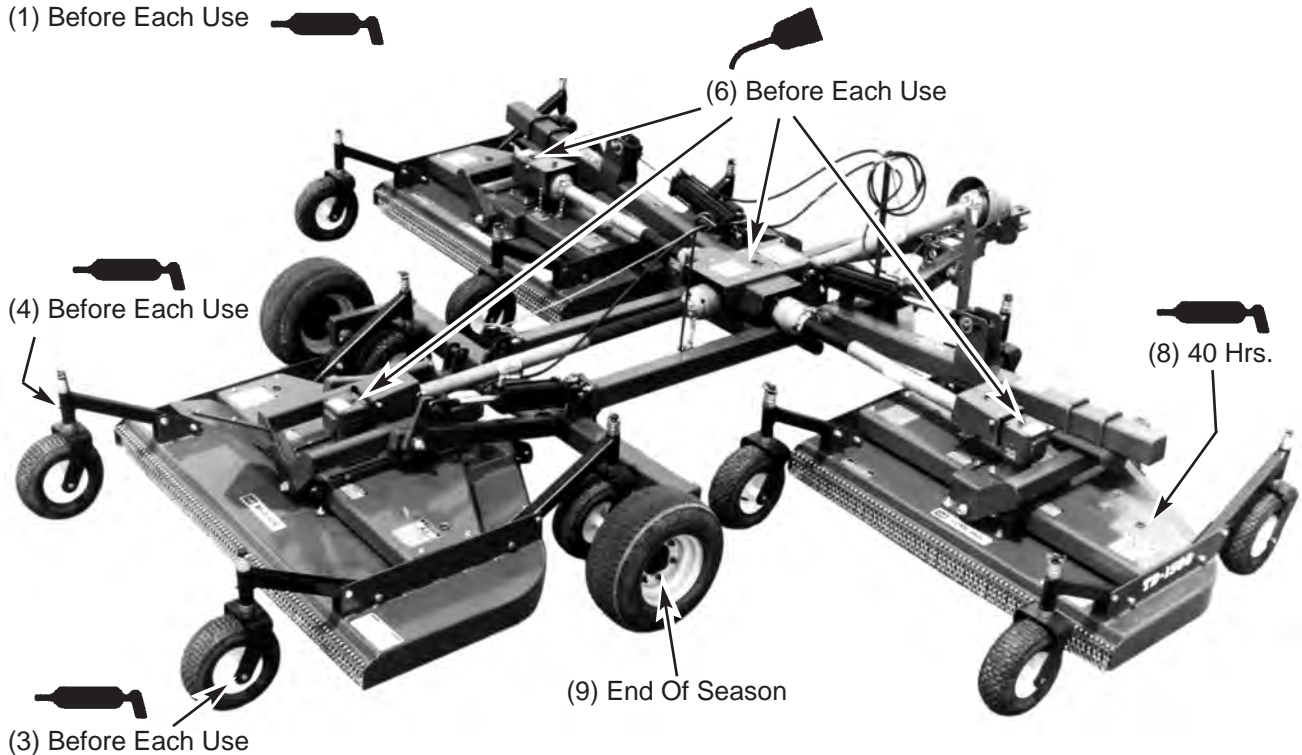
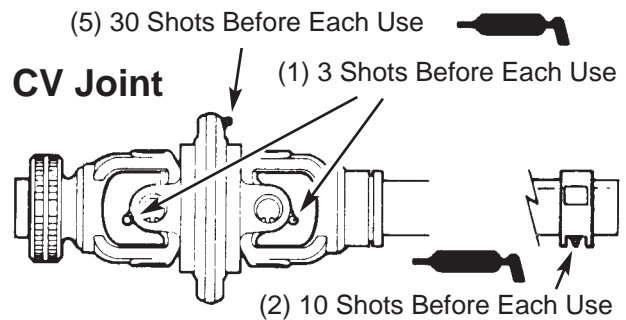
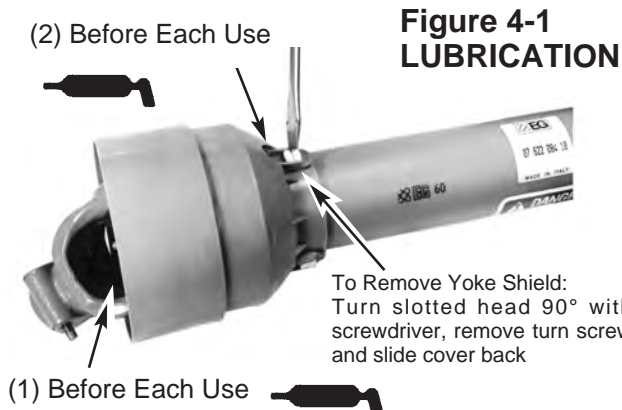

4-3 BELT ADJUSTMENT

Belt tension should be checked every 40 hours to get maximum life from drive belt and best performance from cutter. Belt tension is adjusted by increasing or decreasing the length of the spring on the moveable idler. For proper belt tension on the 60" mowers, the spring length should be set at 6-5/8". For proper belt tension on the 72" mowers, the spring length should be set at 7-7/8". (Figure 4-2). To adjust the spring length, loosen or tighten the 3/8" hex nuts on the spring adjustment rod until the correct spring length is reached. Use only genuine Bush Hog replacement parts.

4-4 BELT REPLACEMENT

- A. Remove right and left side shields.
- B. Relieve spring tension by loosening the two 3/8" hex nuts on the spring adjustment rod.
- C. Remove old belt.
- D. Install new belt, referring to FIGURE 4-2. (Also refer to the decal on the mower deck) Be sure that the belt is properly positioned in all sheave grooves.
- E. Adjust tension on the belt by adjusting the length of the spring on the moveable idler. The correct spring lengths are 6-5/8" and 7-7/8" for the 60" and 72" mowers respectively.
- F. Replace right and left side shields.

Figure 4-2 Belt Diagram

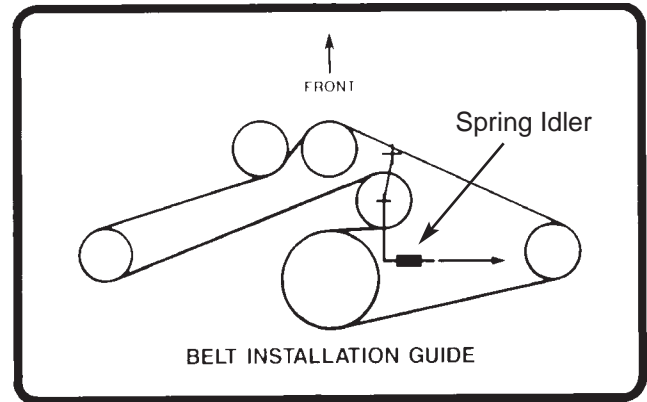

4-5 BLADE REPLACEMENT



WEAR HEAVY WORK GLOVES TO PROTECT HANDS FROM SHARP EDGES.

- A. Raise cutter using tractor hydraulics and **SECURELY BLOCK INTO POSITION.**
- B. Set parking brake, turn off tractor and remove key
- C. Remove bolt and cup washer securing blade to spindle. Remove blade.
- D. Install new blade(s) as shown in Figure 4-3 with concave side of cup washer against blade. Be sure that blades are installed with offset in proper direction. Tighten retaining bolts to 76 ft./lbs.

Figure 4-3 Blade Replacement



4-6 TROUBLESHOOTING

Troubleshooting procedures are listed in Table 4-1 below. If the problem cannot be solved or replacement parts are necessary, contact your authorized Bush Hog dealer. Please have ready your machine name, model number, serial number, purchase date and exact cause or description of problem.

Table 4-1 Troubleshooting

| PROBLEM | PROBABLE CAUSE | REMEDY |
|------------------------------------|---|---|
| Uneven Cut | Cutter not level side to side or front to rear. | See SECTION III. |
| | Belt slipping. | Adjust belt per paragraph 4-3. |
| | Worn or bent blade(s). | Replace blade(s). |
| Streaking or Windrowing | Possible build-up of material under cutter. | Clean cutter. |
| | Cutter not level. | See SECTION III. |
| | Worn blades. | Replace blades. |
| | Belt slipping. | Adjust belt per paragraph 4-3. |
| Noisy Cutter | Loose components. | Check all bolts for tightness. |
| | Low oil in gearbox. | Check oil per paragraph 4-2. |
| Rapid Blade Wear (cutting edge) | Blade contacting ground. | Adjust cutting height to eliminate ground contact. |
| Rapid Blade Wear | Cutter not being operated at rated PTO speed. | Set tractor throttle for proper PTO speed. |
| | | Use lower gear. |
| Cutter Vibrating | Cutter not being operated at rated PTO speed. | Set tractor throttle for proper PTO speed. |
| | Blade(s) bent. | Replace blades. |
| | Foreign object wrapped around spindle or blade. | Remove object. |

SAFETY DECALS

To promote safe operation, Bush Hog supplies safety decals on all products manufactured. Because damage can occur to safety decals either through shipment, use or reconditioning, Bush Hog will, upon request, provide safety decals for any of our products in the field at no charge. Contact your authorized Bush Hog dealer for more information.



50012615



50012616



50042284



50042282



82617



83056

DECALS CONTINUED

⚠ WARNING



TO AVOID SERIOUS INJURY OR DEATH:

- DO NOT OPERATE WITH WINGS RAISED.
- LOCK WINGS UP FOR TRANSPORT.
- STAND CLEAR IF LOWERING OR RAISING WINGS.
- DECREASE SPEED WHEN TURNING. BE CAREFUL ON SLOPES OR UNEVEN TERRAIN WITH WINGS IN RAISED POSITION.
- BE ALERT TO OVERHEAD OBSTRUCTIONS AND ELECTRICAL WIRES WITH WINGS IN RAISED POSITION.

50042289

50042289

⚠ WARNING



TO AVOID SERIOUS INJURY OR DEATH:

- LOCK WINGS UP FOR TRANSPORT
- INSTALL TRANSPORT LOCK PINS
- READ OPERATOR'S MANUAL FOR INSTRUCTIONS

83343

83343

⚠ WARNING



IMPLEMENT CAN FALL FROM HYDRAULIC SYSTEM FAILURE. TO AVOID SERIOUS INJURY OR DEATH:

- SHUT OFF TRACTOR ENGINE, REMOVE KEY, SECURE TRACTOR PARKING BRAKE AND BLOCK UP OR SECURELY SUPPORT IMPLEMENT BEFORE WORKING UNDERNEATH.
- PURGE ALL AIR FROM HYDRAULIC SYSTEM BEFORE ATTEMPTING TO RAISE OR LOWER THIS IMPLEMENT.
- STAND CLEAR IF LOWERING OR RAISING IMPLEMENT.
- DO NOT USE HAND OR SKIN TO CHECK FOR HYDRAULIC LEAKS. USE CARDBOARD OR WOOD.
- HIGH PRESSURE OIL LEAKS CAN PENETRATE SKIN CAUSING SERIOUS INJURY AND GANGRENE. CONSULT A PHYSICIAN IMMEDIATELY.
- LOWER THE IMPLEMENT AND RELEASE HYDRAULIC PRESSURE BEFORE LOOSENING FITTINGS.
- REFER TO OWNER'S MANUAL FOR DETAILS.

82683

82683

⚠ DANGER



ROTATING DRIVELINE
CONTACT CAN CAUSE DEATH
KEEP AWAY!
DO NOT OPERATE WITHOUT -

- ALL DRIVELINE GUARDS, TRACTOR AND EQUIPMENT SHIELDS IN PLACE
- DRIVELINES SECURELY ATTACHED AT BOTH ENDS
- DRIVELINE GUARDS THAT TURN FREELY ON DRIVELINE

399141000
MADE IN ITALY



BONDIOLI & PAVESI

78608

DECALS CONTINUED

 **CAUTION**

THIS IMPLEMENT IS DESIGNED TO OPERATE AT 540 RPM MAXIMUM TRACTOR PTO SPEED.

ALL DRIVELINE SHIELDS MUST BE KEPT IN PLACE.

50042281

50042281

 **WARNING**



ROTARY CUTTERS CAN DISCHARGE OBJECTS SEVERAL HUNDREDS OF FEET. TO AVOID SERIOUS INJURY OR DEATH TO BYSTANDERS FROM THROWN OBJECTS:

- CLEAR MOWING AREA OF VISIBLE DEBRIS AND USE EXTRA CAUTION WHERE ROCKS OR DEBRIS MAY BE PRESENT.
- USE 5/16" DOUBLE ROW HIGHWAY CHAINS FOR ALL ROADSIDE MOWING OPERATIONS.
- DO NOT OPERATE THE CUTTER IN THE VICINITY OF OTHER PERSONS WITHOUT ENCLOSED SIDES, PERMANENT BANDS, HIGHWAY CHAINS OR OTHER FACTORY APPROVED DISCHARGE SHIELDS IN PLACE AND IN GOOD WORKING ORDER.
- KEEP ALL PERSONS WELL CLEAR OF MOWER WHEN IN OPERATION.

50042283

50042283

399143000

 **DANGER**



**GUARD MISSING
DO NOT OPERATE**

399143000

 **DANGER**



**GUARD MISSING
DO NOT OPERATE**

399143000

 **DANGER**

MADE IN ITALY

78786

TORQUE SPECIFICATIONS

Proper torque for American fasteners used on Bush Hog equipment.
Recommended Torque in Foot Pounds (Newton Meters).*

AMERICAN Bolt Head Markings

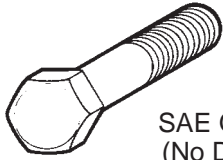

SAE Grade 2
(No Dashes)

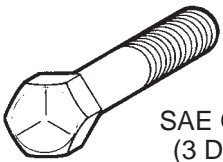

SAE Grade 5
(3 Dashes)

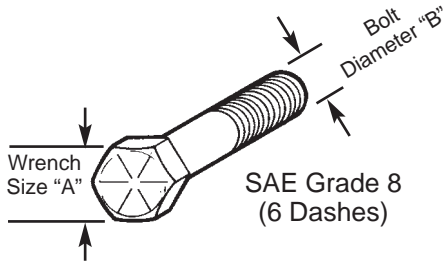

SAE Grade 8
(6 Dashes)

| WRENCH SIZE (IN.) "A" | BOLT DIAMETER (IN.) "B" AND THREAD SIZE | SAE GRADE 2 | SAE GRADE 5 | SAE GRADE 8 |
|-----------------------|---|-------------|-------------|-------------|
| 7/16 | 1/4 - 20 UNC | 6 (7) | 8 (11) | 12 (16) |
| 7/16 | 1/4 - 28 UNF | 6 (8) | 10 (13) | 14 (18) |
| 1/2 | 5/16 - 18 UNC | 11 (15) | 17 (23) | 25 (33) |
| 1/2 | 5/16 - 24 UNF | 13 (17) | 19 (26) | 27 (37) |
| 9/16 | 3/8 - 16 UNC | 20 (27) | 31 (42) | 44 (60) |
| 9/16 | 3/8 - 24 UNF | 23 (31) | 35 (47) | 49 (66) |
| 5/8 | 7/16 - 14 UNC | 32 (43) | 49 (66) | 70 (95) |
| 5/8 | 7/16 - 20 UNF | 36 (49) | 55 (75) | 78 (106) |
| 3/4 | 1/2 - 13 UNC | 49 (66) | 76 (103) | 106 (144) |
| 3/4 | 1/2 - 20 UNF | 55 (75) | 85 (115) | 120 (163) |
| 7/8 | 9/16 - 12 UNC | 70 (95) | 109 (148) | 153 (207) |
| 7/8 | 9/16 - 18 UNF | 79 (107) | 122 (165) | 172 (233) |
| 15/16 | 5/8 - 11 UNC | 97 (131) | 150 (203) | 212 (287) |
| 15/16 | 5/8 - 18 UNF | 110 (149) | 170 (230) | 240 (325) |
| 1-1/8 | 3/4 - 10 UNC | 144 (195) | 266 (360) | 376 (509) |
| 1-1/8 | 3/4 - 16 UNF | 192 (260) | 297 (402) | 420 (569) |
| 1-5/16 | 7/8 - 9 UNC | 166 (225) | 430 (583) | 606 (821) |
| 1-5/16 | 7/8 - 14 UNF | 184 (249) | 474 (642) | 668 (905) |
| 1-1/2 | 1 - 8 UNC | 250 (339) | 644 (873) | 909 (1232) |
| 1-1/2 | 1 - 12 UNF | 274 (371) | 705 (955) | 995 (1348) |
| 1-1/2 | 1 - 14 UNF | 280 (379) | 721 (977) | 1019 (1381) |
| 1-11/16 | 1-1/8 - 7 UNC | 354 (480) | 795 (1077) | 1288(1745) |
| 1-11/16 | 1-1/8 - 12 UNF | 397 (538) | 890 (1206) | 1444 (1957) |
| 1-7/8 | 1-1/4 - 7 UNC | 500 (678) | 1120 (1518) | 1817 (2462) |
| 1-7/8 | 1-1/4 - 12 UNF | 553 (749) | 1241 (1682) | 2013 (2728) |
| 2-1/16 | 1-3/8 - 6 UNC | 655 (887) | 1470 (1992) | 2382 (3228) |
| 2-1/16 | 1-3/8 - 12 UNF | 746 (1011) | 1672 (2266) | 2712 (3675) |
| 2-1/4 | 1-1/2 - 6 UNC | 870 (1179) | 1950 (2642) | 3161 (4283) |
| 2-1/4 | 1-1/2 - 12 UNF | 979 (1327) | 2194 (2973) | 3557 (4820) |

METRIC

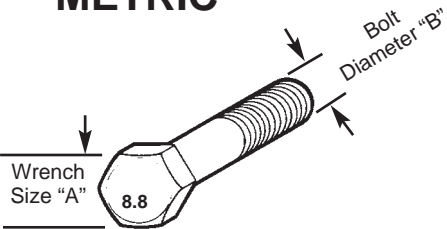

Numbers appearing on bolt heads indicate ASTM class.

Proper torque for metric fasteners used on Bush Hog equipment.
Recommended torque in foot pounds (newton Meters).*

| WRENCH SIZE (mm) "A" | BOLT DIA. (mm) "B" | ASTM 4.6 | ASTM 8.8 | ASTM 9.8 | ASTM 10.9 |
|----------------------|--------------------|-----------|-------------|-----------|-------------|
| 8 | 5 | 1.8 (2.4) | | 5.1 (6.9) | 6.5 (8.8) |
| 10 | 6 | 3 (4) | | 8.7 (12) | 11.1 (15) |
| 13 | 8 | 7.3 (10) | | 21.1 (29) | 27 (37) |
| 16 | 10 | 14.5 (20) | | 42 (57) | 53 (72) |
| 18 | 12 | 25 (34) | 74 (100) | 73 (99) | 93 (126) |
| 21 | 14 | 40 (54) | 118 (160) | 116 (157) | 148 (201) |
| 24 | 16 | 62 (84) | 167 (226) | 181 (245) | 230 (312) |
| 30 | 20 | 122 (165) | 325 (440) | | 449 (608) |
| 33 | 22 | | 443 (600) | | 611 (828) |
| 36 | 24 | 211 (286) | 563 (763) | | 778 (1054) |
| 41 | 27 | | 821 (1112) | | 1138 (1542) |
| 46 | 30 | 418 (566) | 1119 (1516) | | 1547 (2096) |

*Use 75% of the specified torque value for plated fasteners. Use 85% of the specified torque values for lubricated fasteners.

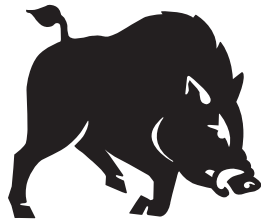

BUSH HOG[®]
Performance You Can Count OnSM

2501 Griffin Ave. • Selma, AL 36703
Telephone (334) 874-2700 • www.bushhog.com