

— *Lighthouse Larry*



SIDEBAND HANDBOOK

First Edition

AN EDUCATIONAL PUBLICATION
OF
RECEIVING TUBE DEPARTMENT

GENERAL  ELECTRIC

Owensboro, Kentucky

PRICE: \$2.00 in U.S.A.
\$2.50 Elsewhere

Lighthouse Larry



SIDEBAND HANDBOOK

First Edition

**AN EDUCATIONAL PUBLICATION
OF
RECEIVING TUBE DEPARTMENT**

GENERAL  ELECTRIC

Owensboro, Kentucky

INTRODUCTION

Interest by radio amateurs in single sideband and other suppressed-carrier transmission and reception techniques for voice communication has grown by leaps and bounds since some pioneering experiments were conducted by radio amateurs back in the 1940's.

And a large part of this pioneering happened right at *General Electric*, where scientists (who also were radio amateurs) at *General Electric's* world-famous Research Laboratory developed wide-band audio frequency phase-shift networks.

These patented networks made possible the generation of a single sideband, suppressed-carrier signal at high radio frequencies. They simplified the design of single sideband transmitters by eliminating additional circuits required to convert the SSB signal usually generated in a low frequency filter up to the operating frequency.

From this key research, the design and construction of simple phasing type projects which have been described in *G-E HAM NEWS* followed. These articles include the famous "SSB, Jr." 5-watt SSB transmitter; the "Signal Slicer" receiving adapter; and similar circuits. Our records show that thousands of radio amateurs constructed their first SSB equipment from the original *G-E HAM NEWS* designs.

And, again in the 1950's, pioneering work by radio amateurs at *General Electric* resulted in still more simplification of suppressed-carrier transmitters by using the double sideband techniques evolved from synchronous communications studies made by *General Electric*.

All of this wealth of background material from *G-E HAM NEWS* has been reprinted in this first edition of *Lighthouse Larry's Sideband Handbook*. In addition, later information on many of the articles on sideband has been compiled and follows the reprints of the original articles.

We've also included some key articles on subjects related to sideband in this handbook, such as linear amplifiers, RF and audio accessories, and power supplies. Especially noteworthy is the original *G-E HAM NEWS* articles on Dynamic Power Supply Regulation which prompted more radio amateurs to use high-capacitance filter.

We dedicate this book to the radio amateurs who have pioneered and furthered suppressed-carrier communications techniques. And, at *G-E HAM NEWS*, we're proud of our small part in making sideband in amateur radio a success.

73,

—*Lighthouse Larry*

ARTICLES

	Page No.
CHAPTER I — HETRODYNYING AND MIXING.....	I-5
What About Mixer Circuits?	
From November-December, 1956.....	I-5
Using the G-E 6AR8 Sheet Beam Tube.....	I-11
CHAPTER II — SIDEBAND GENERATORS AND EXCITERS.....	II-1
SSB, Jr. 5-Watt SSB Transmitter	
From November-December, 1950.....	II-1
200-Watt Double Sidebander From May-June, 1959.....	II-13
Double Sideband Junior From March-April, 1958.....	II-24
K2GZT's 6146 Double Sideband Transmitter.....	II-31
DSB Considerations and Data.....	II-33
Hetrodyne Exciter with 6BU8 Twin Pentode Balanced Mixer.....	II-36
Hetrodyne VFO for 9-Mc. SSB Generators.....	II-39
CHAPTER III — TRIODE LINEAR AMPLIFIERS.....	III-1
Lazy Linear Amplifier With Push-Pull GL-811-A Triodes	
From July-August, 1949.....	III-1
Power Peaker Linear Amplifier	
From September-October, 1952.....	III-10
Compact Triode Kilowatt	
From September-October, 1959.....	III-16
Comparison of DSB and SSB.....	III-26
Maximum Ratings and Typical Operating Conditions	
for Transmitting Tubes.....	III-27
Computing Driving Power for Transmitting Tubes.....	III-28
Frequency Limitations on Transmitting Tubes.....	III-28
CHAPTER IV PENTODE LINEAR AMPLIFIERS.....	IV-1
Kilowatt Grounded-Grid Linear Amplifier With Paralleled	
GL-813's From November-December, 1959.....	IV-1
600-Watt All-Band Amplifier for CW, AM or SSB Linear	
Service From November-December, 1954.....	IV-12
Technical Tidbits Caution — Screen Grid at Work.....	IV-19
Bandswitching Mobile Linear Amplifier with GL-4D21/4-	
125-A's From November-December, 1960.....	IV-20
Technical Tidbits — Proper Tank Circuit Padding.....	IV-25
Proper Tank Circuit "Q" and Loading.....	IV-27
CHAPTER V SIDEBAND RECEPTION AND ADAPTERS	V-1
The Signal Slicer From July-August, 1951.....	V-1
Packaged Selectivity From March-April, 1957.....	V-13
Mobile SSB Reception.....	V-18
Bandswitching Mobile Converter.....	V-19
Single Band Mobile Converters.....	V-23
Converting the BC-453 Receiver.....	V-26
12-Tube Adapter for Single Sideband Reception	
From November-December, 1948.....	V-31
The G-E Model YRS-1 Adapter for Single Sideband	
Reception.....	V-36

	Page No.
CHAPTER VI RF ACCESSORIES FOR SIDEBAND.....	VI-1
Solid High-C VFO From July-August, 1959.....	VI-1
The Hamscope From September-October, 1956.....	VI-5
The Dioplex From March-April, 1953.....	VI-14
CHAPTER VII AUDIO ACCESSORIES FOR SIDEBAND	
Restricting Frequency Range in Transmitter Audio Systems From July-August, 1949.....	VII-1
Restricted Range Speech Amplifier From September-October, 1949.....	VII-3
Logarithmic Compressor From May-June, 1950.....	VII-7
High Attenuation Low-Pass Audio Filter From March-April, 1955.....	VII-13
Combo Monitor From September-October, 1958.....	VII-18
Power Control Panel From March-April, 1954.....	VII-20
CHAPTER VIII POWER SUPPLIES FOR SIDEBAND.....	VIII-1
About Power Supplies From January-February, 1954.....	VIII-1
Two High-C Power Supplies.....	VIII-4
Designer's Corner — Designing Power Supplies.....	VIII-8
Dual-Voltage Power Supplies From September-October, 1957.....	VIII-10
High Power Mobile Power Systems.....	VIII-20
Mobile Power Supply Ideas From July-August, 1960.....	VIII-21
Construction Details for 3-Phase Distribution Stepup Transformer.....	VIII-26
CHAPTER IX TRANSMITTING TUBE TESTING AND OPERATING HINTS.....	IX-1
Simplified Test Procedures for Popular Transmitting Tubes.....	IX-1

This work is an educational publication for radio amateurs compiled and published by the Receiving Tube Department of the

General Electric Company, Owensboro, Ky., to further interest in the hobby of amateur radio. All rights are reserved.



**HAM
NEWS**

**presents HOW-TO-DO-IT IDEAS
from the 999 radio amateurs at**

GENERAL  ELECTRIC

A bi-monthly publication of the RECEIVING TUBE DEPARTMENT
Owensboro, Kentucky, U. S. A. • Editor — E. A. Neal, W4ITC

G-E HAM NEWS is available free from authorized G-E Tube distributors. Some distributors mail copies locally to their customers.

A low-cost direct-mail subscription plan is available to persons residing in the United States and its possessions (including APO and FPO numbers).

Subscription rates are:

One Year (6 issues).....	\$1.00
Two Years (12 issues).....	\$2.00
Three Years (18 issues).....	\$3.00
Five Years (30 issues).....	\$4.00

Enclose check or money order for U. S. currency for the proper amount above made payable to "General Electric Company."

Residents of Canada may subscribe to G-E HAM NEWS for \$1.00 per year from the Canadian General Electric Company, Ltd., Electronic Tube Market-

ing Section, 189 Dufferin Street, Toronto 3, Ontario, Canada. Enclose check or money order made payable to: "Canadian General Electric Company, Ltd."

Distribution of G-E HAM NEWS in more than 40 foreign countries is handled through the International General Electric Company. A listing of outlets is available from the G-E HAM NEWS office. Or, write to: Customer Inquiry Section, International General Electric Company, 150 East 42nd Street, 7th Floor, New York 17, New York, U. S. A.

NOTE: The disclosure of any information or arrangements herein conveys no license under any patents of General Electric Company or others. In the absence of an express written agreement to the contrary, the General Electric Company assumes no liability for patent infringement (or any other liability) arising from the use of such information by others.

HETRODYNING AND MIXING

What About Mixed Circuits? From November-December, 1956

Mixers (modulators) can have simple or complex, single-ended or push-pull (balanced) circuitry, operate at low or high level, and employ diodes or multi-element tubes. A single-ended diode mixer (the circuit used in most UHF television tuners) and the balanced diode mixer (two of them are used in the SSB, Jr.) are more foolproof than multi-element tube mixers, but no power gain can be obtained, and the diode mixer is likely to have high harmonic output. This is the price of simplicity plus low distortion in the output signal.

Although a triode tube may be used as a mixer, both input signals must be applied to the control grid, or to the control grid and cathode, respectively. Even though generation of harmonics in a triode mixer is apt to be lower than in a diode circuit, the operating conditions must be carefully controlled to avoid distortion of the output signal. This applies equally to pentodes and the multi-grid tubes designed especially for mixer service in superheterodyne radio receivers. Mixer circuits for these tubes usually feed each mixer input signal into a separate grid, where the signals are combined in the tube's electron stream. A circuit tuned to the desired output signal frequency is connected to the tube's plate. Each of the mixer tube's input signal grids should operate in the Class A region for lowest harmonic output, since the amplitude of input signal harmonics *generated* in the mixer depends on the operating point and amplitude of the input signals. Even though a pentagrid mixer stage requires critical adjustment for minimum distortion, it will have a lower harmonic output when properly adjusted than the other types of mixers.

Since normal Class A amplifier efficiency is only 25—30 per cent, and that of a Class A mixer is even lower, much of a properly operated mixer tube's input power is dissipated instead of appearing as output

power. For this reason, a high-level mixer tube will have much lower power output than the same tube in a linear amplifier. Even the minute power output from a low-level mixer stage can be brought up to a respectable level in one high gain linear amplifier stage.

Even though single-ended mixer circuits are widely used, the balanced mixer circuit offers the inherent advantage of cancelling the fundamental and certain harmonics of at least one, and possibly both, input signals. Usually this type of mixer can be precisely balanced for maximum attenuation of the fundamental or a particular harmonic of either input signal, but not all simultaneously. In general, a properly operated balanced mixer using pentagrid tubes will have low harmonic generation properties, but other mixers will not, whether balanced or otherwise.

The actual circuitry for a pentagrid balanced mixer may have both pairs of input signal grids connected to separate push-pull tank circuits, with the tube plates connected in parallel to a single-ended tuned circuit, or one pair of grids may be connected in push-pull, the other pair of signal grids in parallel, and the plates connected to a push-pull tank circuit. The mixer input signal on which cancellation is desired should be applied to the signal grids through the push-pull tank circuit. However, under certain conditions, it is possible to cancel out the desired output signal!

Any balanced mixer may become unbalanced due to component aging and operating voltage changes, so a mixer balancing adjustment should be provided in the circuit. Finally, the pentagrid tube balanced mixer circuit may help reduce those spurious signals which cannot be readily attenuated with special trap circuits, or by depending on the skirt selectivity of cascaded tuned circuits at the mixer output frequency.

THE MIX-SELECTOR CHART

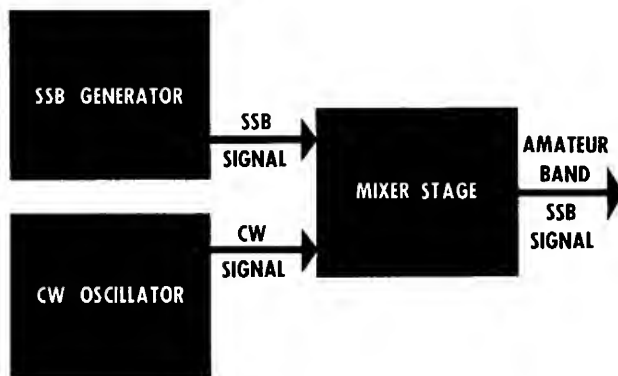

Watch your signals when designing that new multi-band SSB exciter or heterodyne-type VFO for your present CW or AM transmitter. Our MIX-SELECTOR chart explains why signal frequencies employed in heterodyning must be carefully selected to avoid the transmission of spurious signals along with your desired signal. Examine our typical signal combination examples—then try working out your own ideas on logarithmic graph paper!

Single Sideband Background

The rapidly increasing interest in single-sideband transmission and reception on the amateur bands focuses attention on the basic differences between single-sideband suppressed carrier transmitters and the old more conventional RF system used in CW and AM transmitters. A simplified block diagram of the usual AM or CW rig, Fig. 1, shows the RF tube lineup starting with an oscillator, often followed by buffer or harmonic amplifiers which then drive one or more amplifier stages at the output frequency. Modulation usually is applied to the final RF amplifier stage in one of several ways which differ mainly in the amount of audio power required for the modulation process.

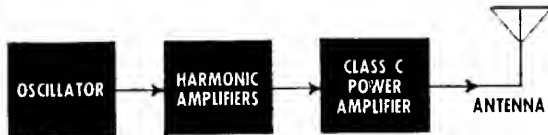

Fig. 1. Block diagram of a typical multi-stage transmitter to which a CW or AM system may be connected.

GENERATING SINGLE SIDEBAND SIGNALS

What are the "sidebands" usually associated with voice modulation of a transmitter? Basically, they are groups of radio frequencies which result from mixing (or modulating) a fixed radio frequency signal with one or more audio signal frequencies. These signals add to and subtract from the fixed frequency to form the above-mentioned groups of closely related radio frequency signals both lower and higher than the fixed frequency. The number of individual signals present in both sets of sidebands at any one time depends upon the number of individual signal frequencies present in the modulating signal.

Probing the mysteries of present-day single-sideband techniques brings forth a multitude of other terms such as: sideband filter, phase-shift network, balanced modulator—etc. Understanding single sideband is further complicated by mention of two systems of generating a single-sideband-suppressed-carrier signal (which we will call SSB in the balance of this discussion): (1) the filter system, and (2) the phasing system.

In both systems, SSB signals are derived from amplitude-modulated signals. In the filter system, an amplitude-modulated signal is passed through a filter which attenuates one of the two sets of sidebands characteristic of amplitude modulation. The phasing system consists of two amplitude-modulated systems combined in such a manner that one set of sidebands is reinforced while the other is cancelled. In either system, it is customary to balance out the so-called carrier from a signal that would otherwise be a completely standard amplitude-modulated signal. When properly adjusted, both systems will deliver the same type of output signal.

Obviously, the filter requirements in that system are quite strict, since all desired signals in one set of side frequencies must be passed, yet the signals appearing in the unwanted set of side frequencies should be attenuated at least 30 db (1000 to 1 in power) or more. The required order of filter selectivity is most easily achieved at frequencies below 500 kilocycles. Thus, many filter-type SSB amateur transmitters now on the air have the SSB generator circuits operating on 450 kilocycles, using either a mechanical filter, or a lattice-type filter made from quartz crystals.

In the phasing system, the signal can be generated at any desired output frequency, but it is inconvenient to change frequency easily. In fact, it is difficult—that is, cumbersome and expensive—to generate an SSB signal at a number of chosen frequencies and select one by bandswitching with either system.

A further limitation in obtaining an SSB output signal on several amateur bands in both filter and phasing systems is that harmonics of the SSB generator cannot be used. The reason is that frequency multiplication depends upon non-linear operation of the multiplier stage, and such operation introduces intolerable distortion to a signal whose character is already established, such as an AM or SSB signal.

We now have indicated, first, that components are not readily available for a filter-type SSB generator designed to operate directly on an amateur band; second, that the phasing system can be used at any desired narrow band of frequencies, but does not lend itself to convenient bandswitching; and third, that harmonics of the SSB generator signal cannot be used.

The really practical solution to the band-changing and adjustable-frequency SSB generator problem, for the home constructor, is to employ the same principle used in superheterodyne receivers. That process is to heterodyne an SSB generator signal, which may be outside the amateur bands, to the desired amateur frequency. The block diagram on page 1 shows the two signal generating stages connected to a mixer stage.

FREQUENCY CONVERSION

Frequency conversion, also known as heterodyning, is simply a process of combining two signals of different frequency to form two new additional signals having frequencies which are, respectively, the sum and the difference of the two original signal frequencies. The circuit in which heterodyning takes place is usually called a mixer, converter or modulator. (They are essentially the same thing.)

There are many types of mixer circuits, but most will generate harmonics of both frequencies being applied to them even though the harmonic content of the input signals is very low. Thus, many signal frequencies can be present in the output of a mixer stage—the two input signals, their sum and difference signals, and the harmonics of both input signals.

All signals except the one desired output signal frequency must be considered as spurious signals. Therefore adequate precautionary measures must be taken to prevent these spurious signals from appearing in the transmitter output.

An important step to ensure adequate suppression of spurious signals is to have at least two high-selectivity tuned circuits resonant at the desired output frequency in the stages following the mixer circuit. If each of these tuned circuits has a "Q" of 100, spurious signals which are 10 per cent lower or higher in frequency than the mixer output signal will be attenuated more than 50 db (100,000 to 1 in power). Spurious signals within 10 per cent of the output signal frequency will be attenuated much less. Practically speaking, neither of the mixer input signal frequencies nor their harmonics should fall within this 20-percent range or they may appear along with the output signal to an appreciable extent.

Since it already has been pointed out that most mixer circuits will generate harmonics of the input signals, these harmonic frequencies also should not fall within 10 per cent of the desired mixer output signal frequency. Ideally, the best way to avoid spurious signals resulting from harmonics of the input signals is to place both mixer input signal frequencies higher than the output signal frequency. This cannot always be done, especially when converting the output from a filter-type SSB generator, which usually operates below 500 kilocycles, to the assigned amateur frequencies.

Since the phasing-type SSB generator operating frequency is not similarly restricted, the signal may be placed higher in frequency than the amateur band on which output is desired. In practice, this is not strictly followed, since an SSB generator signal frequency in the 3.8- to 10-megacycle range is usually chosen for 14-, 21- and 28-megacycle transmitters.

USING THE MIX-SELECTOR CHART

We hope the old saying, "One picture is worth ten thousand words," applies equally to the **MIX-SELECTOR** chart on pages 4 and 5. However, a brief line-by-line explanation will be given to clarify these typical examples of signal frequencies used in heterodyne-type **SSB** exciters.

The "LEGEND" on page 5 pictures the marks used for identifying mixer input and output signals as follows: Fixed frequency input signals are shown as narrow vertical black lines. Second, variable frequency mixer input signals are shown as black blocks whose width is indicative of the frequency range covered. Each fundamental frequency signal is identified with a figure "1," and the harmonics by numbers representing their order. The height of the lines and blocks decreases as the harmonic order increases to illustrate the decreasing relative importance of the higher order harmonics as spurious signals.

Frequencies from 1.5 to 60 megacycles are numbered on line 1 and indicated by vertical lines running down the chart. This frequency span covers most amateur bands on which **SSB** techniques presently are employed. The U.S. amateur radiotelephone segments in each amateur band are identified by the solid black blocks on line 2, which then are carried down the chart in grey shaded bands.

The **FEEDTHRU DANGER ZONE**, previously described under **FREQUENCY CONVERSION**, is marked by the pink areas beginning at line 3 and running down on either side of each amateur 'phone band segment. The left margin of each pink area is considered to be 10 per cent lower in frequency than each 'phone band lower edge, and the right pink margin represents a frequency 10 per cent higher than the upper limit of the same 'phone segment. Of course these danger zones apply only to the amateur band on which the desired mixer output signal is shown, for each horizontal listing on the chart.

FILTER-TYPE SSB GENERATOR FREQUENCIES

Line 4 shows the harmonic signals of a 0.45-megacycle filter-type **SSB** generator, beginning at 1.8 megacycles with its fourth harmonic. The 0.45-megacycle signal frequency must be heterodyned to the amateur bands to be useful. Suppose it is desired to operate in the 1.8–2.0 megacycle band with a 0.45-megacycle filter-type **SSB** generator signal. A difference frequency mixer output signal can be obtained by operating the other mixer input signal range at 2.25–2.45 megacycles, as shown by the solid black block marked "1" on line 5. Notice that the **SSB** generator fourth harmonic signal at 1.8 megacycles is within the feedthrough danger zone and may appear in the mixer output. The strength of this spurious signal will depend upon the type of mixer circuit used. It is clear that a mixer having extremely low harmonic output is necessary to avoid troublesome effects caused by the fourth harmonic generated within the mixer. The high selectivity tuned circuits which should follow the mixer stage for the purpose of attenuating the 2.25–2.45-megacycle signal also will attenuate the higher order harmonics shown by the other black blocks marked "2," "3," "4" and "5" on line 5.

When a mixer output signal in the 3.8–4.0-megacycle range is desired, a heterodyning signal either lower (3.35–3.55 megacycles) or higher (4.25–4.45 megacycles) may be used, as shown in lines 6 and 7, respectively. Note that both heterodyning signal ranges (the black blocks marked "1" on lines 6 and 7) fall partly within the feedthrough danger zone of 3.4–4.4 megacycles. Attenuating these adjustable frequency signals with a trap circuit is more difficult than trapping out a fixed frequency, since one tuning adjustment of the trap probably will not be effective over the entire range. In this case a balanced mixer which cancels the variable frequency mixing signal would be desirable.

Since the heterodyning signals mentioned thus far permit operation on only two bands, the practice followed in many filter-type **SSB** exciters is to again heterodyne the 3.8–4.0-megacycle **SSB** signal described in lines 6 and 7 to the other amateur bands in a second mixer stage. A block diagram of a typical double conversion **SSB** exciter is shown in Fig. 2. This variable **SSB** signal frequency, its spurious signals and harmonics must now be considered as an input signal to the second mixer, as plotted on line 8. If an output signal from the second mixer in the 1.8–2.0-megacycle range is again desired, a fixed frequency signal of either 2.0 or 5.8 megacycles also should be used to mix with the 3.8–4.0-megacycle **SSB** generator signal. A 2.0-megacycle signal would be a poor choice, since it falls within the feedthrough danger zone, but line 9 on the chart shows that the 5.8-megacycle input signal is satisfactory.

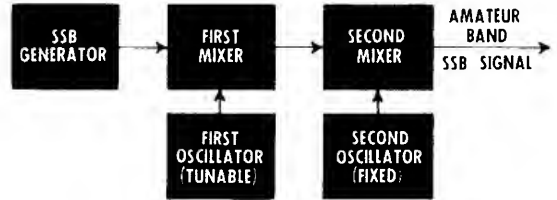

Fig. 2. Block diagram of a double-conversion **SSB** exciter. High-selectivity tuned circuits should immediately follow both first and second mixer stages to avoid transmitting spurious signals from either mixer.

For a second mixer output signal on 7.2–7.3 megacycles, the second harmonic signal of the **SSB** generator, 7.6–8.0 megacycles, falls within the feedthrough danger zone. This also happens with the second harmonic of a 3.3-megacycle mixing signal shown in line 10. One spurious signal can be avoided by choosing 11.1 megacycles, on line 11, for a mixing signal frequency instead. As before, a mixer which does not generate harmonics is necessary. On line 12, the fourth harmonic of the **SSB** generator signal falls within the danger zone for 14.2–14.3-megacycle second mixer output, but the 10.3-megacycle mixing signal should not prove troublesome.

As indicated on line 13, the fifth and sixth harmonics of the **SSB** generator signal will fall within the feedthrough danger zone when a second mixer output signal on 21.25–21.45 megacycles is desired. However, the 17.45-megacycle mixing signal required for this output signal frequency is well outside the danger zone. Again, when an **SSB** signal at 28.5 megacycles is required, as shown on line 14, the seventh and eighth harmonics of the **SSB** generator signal may appear in the second mixer output. The 24.7-megacycle mixing signal appears to be a safe choice. All the foregoing examples indicate that a mixer which has very low harmonic output, plus a balanced type in some cases, should be chosen.

THE 9-MEGACYCLE PHASING-TYPE SSB GENERATOR

A common practice when designing a phasing-type all-band **SSB** exciter is to choose an **SSB** generator signal frequency which permits the same mixing signal frequency range to be used for a mixer output signal on either of two bands. But, this is not the primary consideration, since a frequency whose harmonics fall outside the feedthrough danger zones of any desired operating band should be chosen. The widely-used 9-megacycle **SSB** generator signal frequency is good, but has certain disadvantages. Line 15 on the chart shows that the third harmonic, at 27 megacycles, falls within the danger zone when a mixer output signal in the 28-megacycle band is desired. Again, suitable mixer design is necessary to reduce the severity of this spurious signal.

(Continued on page I-10)

MIX-SELECTOR CHART

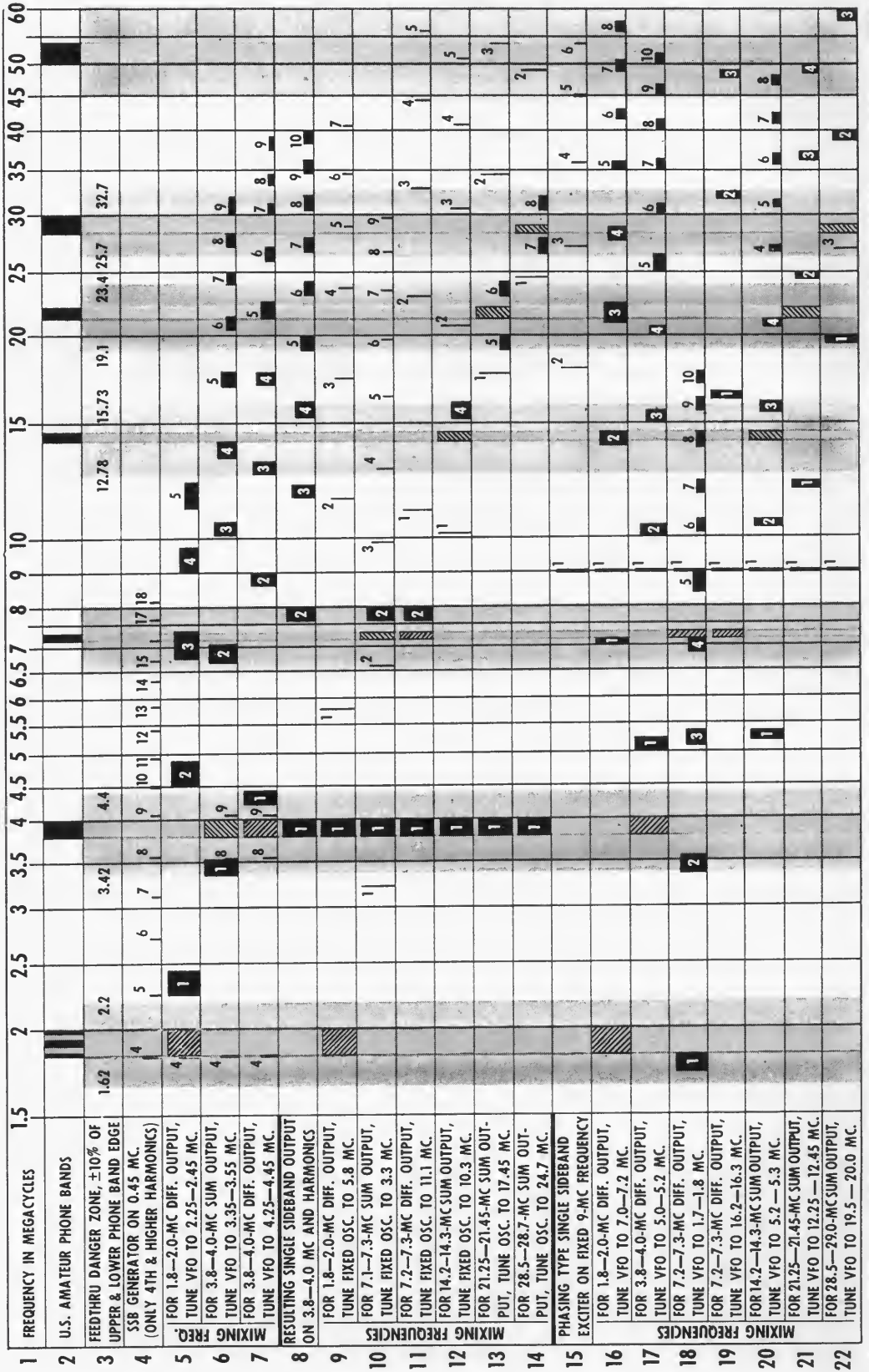

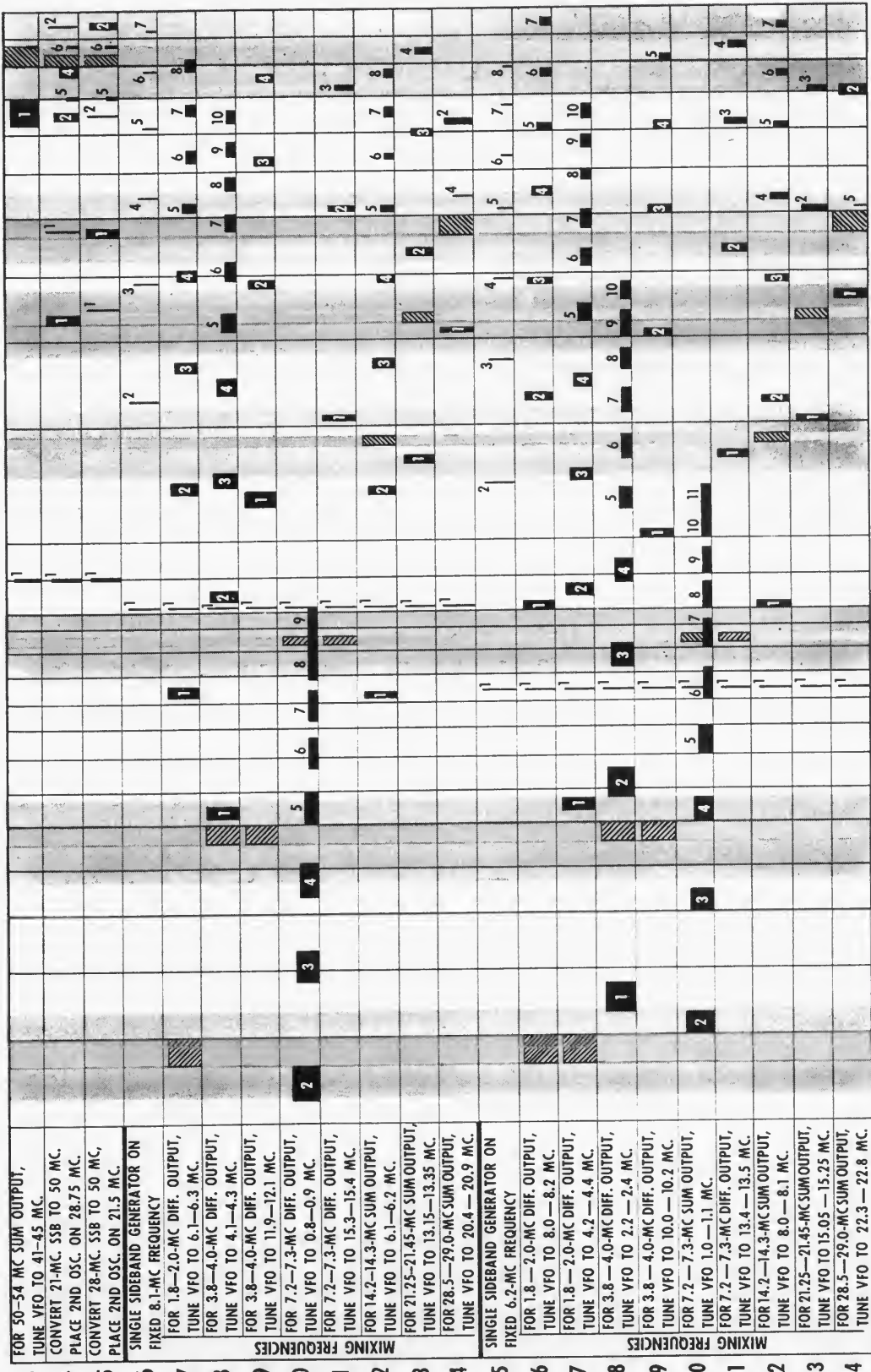

23 FOR 50-54 MC SUM OUTPUT, TUNE VFO TO 41-45 MC.
 24 CONVERT 21-MC. SSB TO 50 MC. PLACE 2ND OSC. ON 28.75 MC.
 25 CONVERT 28-MC. SSB TO 50 MC. PLACE 2ND OSC. ON 21.5 MC.
 26 SINGLE SIDEBAND GENERATOR ON FIXED 8.1-MC FREQUENCY
 27 FOR 1.8-2.0-MC DIFF. OUTPUT, TUNE VFO TO 6.1-6.3 MC.
 28 FOR 3.8-4.0-MC DIFF. OUTPUT, TUNE VFO TO 4.1-4.3 MC.
 29 FOR 3.8-4.0-MC DIFF. OUTPUT, TUNE VFO TO 11.9-12.1 MC.
 30 FOR 7.2-7.3-MC DIFF. OUTPUT, TUNE VFO TO 0.8-0.9 MC.
 31 FOR 7.2-7.3-MC DIFF. OUTPUT, TUNE VFO TO 15.3-15.4 MC.
 32 MIXING FOR 14.2-14.3-MC SUM OUTPUT, TUNE VFO TO 6.1-6.2 MC.
 33 FOR 21.25-21.45-MC SUM OUTPUT, TUNE VFO TO 13.15-13.35 MC.
 34 FOR 28.5-29.0-MC SUM OUTPUT, TUNE VFO TO 20.4-20.9 MC.
 35 SINGLE SIDEBAND GENERATOR ON FIXED 6.2-MC FREQUENCY
 36 FOR 1.8-2.0-MC DIFF. OUTPUT, TUNE VFO TO 8.0-8.2 MC.
 37 FOR 1.8-2.0-MC DIFF. OUTPUT, TUNE VFO TO 4.2-4.4 MC.
 38 FOR 3.8-4.0-MC DIFF. OUTPUT, TUNE VFO TO 2.2-2.4 MC.
 39 FOR 3.8-4.0-MC DIFF. OUTPUT, TUNE VFO TO 10.0-10.2 MC.
 40 MIXING FOR 7.2-7.3-MC SUM OUTPUT, TUNE VFO 1.0-1.1 MC.
 41 FOR 7.2-7.3-MC DIFF. OUTPUT, TUNE VFO TO 13.4-13.5 MC.
 42 TUNE VFO TO 8.0-8.1 MC.
 43 FOR 21.25-21.45-MC SUM OUTPUT, TUNE VFO TO 15.05-15.25 MC.
 44 FOR 28.5-29.0-MC SUM OUTPUT, TUNE VFO TO 22.3-22.8 MC.

LEGEND:

 1 FIXED MIXING FREQ AND HARMONICS

 2-10 VARIABLE MIXING FREQ AND HARMONICS

 11 MIXER DIFFERENCE OUTPUT FREQ

 12-10 MIXER SUM OUTPUT FREQ

A variable frequency oscillator must be used with this fixed SSB generator signal if an adjustable frequency mixer output signal is desired for the amateur bands. The VFO tuning ranges required for mixer output on 1.8–2.0 and 3.8–4.0 megacycles (7.0–7.2 and 5.0–5.2 megacycles, respectively) are shown on lines 16 and 17. These two examples both illustrate the desirable feature of having both mixer input signals higher in frequency than the output signal.

Two possible mixer input signal combinations for 7.2–7.3-megacycle mixer output are shown on lines 18 and 19. Note that the fourth harmonic of the 1.7–1.8-megacycle VFO signal on line 18 falls within the danger zone, so the 16.2–16.3-megacycle VFO range is a better choice. For a 14.2–14.3-megacycle mixer output signal on line 20, the VFO tuning range of 5.2–5.3 megacycles may be used. However, the VFO third harmonic signal at 15.6–15.9 megacycles is within the feedthrough danger zone. A trap circuit in the mixer output to attenuate this spurious signal is included in one type of commercial SSB exciter. Note that lines 17 and 20 are typical examples of getting two-band operation with one VFO signal range.

The mixer input signals required for 21.25–21.45 and 28.5–29.0-megacycle mixer sum output signals (12.25–12.45 and 19.5–20.0 megacycles, respectively) shown on lines 21 and 22 present no special problems. Or, VFO signals in the 30.25–30.45 and 37.5–38.0-megacycle ranges, respectively, may be used for mixer output on these bands if the stability of the higher frequency VFO is adequate. This problem is even greater when a 50-megacycle mixer output signal is desired. A VFO range of 41–45 megacycles is then required, as shown on line 23.

Methods of obtaining a 50-megacycle SSB output signal are shown on chart lines 24 and 25. A variable frequency SSB exciter having output on the 21- or 28-megacycle bands may be fed into a second mixer stage from which the 50-megacycle signal is obtained. On line 24, a signal on 28.75 megacycles, and the SSB exciter signal on 21.25–21.45 megacycles are mixed to obtain a 50.0–50.2-megacycle mixer output signal.

On line 25, an SSB exciter output signal in the 28.5–29.0-megacycle range is mixed with a 21.5-megacycle signal to obtain a 50–50.5-megacycle SSB output signal from the second mixer. Fewer spurious signal difficulties may be experienced with this combination. All signals which are involved in a double-heterodyning transmitter should in themselves be free of spurious signals. If not, a pyramiding of spurious signals is possible at the output of the second conversion stage.

OTHER PHASING SSB GENERATOR FREQUENCIES

The third harmonic of the SSB generator in the 9-megacycle range, shown on line 15 at 27 megacycles, may be shifted so that it falls between the feedthrough danger zones for the 21- and 28-megacycle amateur bands by selecting a lower SSB generator frequency around 8 megacycles. The chart shows a good example on line 26, 8.1 megacycles, which has only the fourth harmonic falling at the upper edge of the 29.7-megacycle danger zone. This particular frequency permits a common VFO tuning range to be used for 1.8–2.0 (line 27) and 14.2–14.3-megacycle (line 32) mixer output signals. Two choices are shown for a 3.8–4.0-megacycle mixer output signal. The 4.1–4.3-megacycle VFO tuning range on line 28 falls within the danger zone, so the 11.9–12.1-megacycle range on line 29 is better.

Look what happens when a low-frequency VFO tuning range (0.7–0.8 megacycles on line 30) is used for a mixer output signal in the 7.2–7.3-megacycle band! The VFO eighth and ninth harmonics both land in the mixer output range, requiring excellent mixer design to avoid almost certain trouble from spurious signals. Placing the VFO range at 15.3–15.4 megacycles, as shown on line 31, avoids this problem. The two VFO

tuning ranges required for sum mixer output signals in the 21.25- and 28.5-megacycle bands are illustrated on lines 33 and 34. Output in the 50-megacycle band may be obtained with double conversion signal combinations similar to those shown on lines 24 and 25.

Most SSB generator signal frequencies below 5 megacycles will have harmonics falling within several feedthrough danger zones. But, by going a bit higher in frequency, to the 6.2–6.5-megacycle range, all lower order harmonics except the fifth are in the clear. A frequency of 6.2 megacycles (line 35) enables the same VFO tuning range (8.0–8.2 megacycles) to be used for mixer output signals on 1.8–2.0 megacycles (line 36) and 14.2–14.3 megacycles (line 42). An alternate VFO tuning range (4.0–4.2 megacycles) for 1.8–2.0-megacycle output is shown on line 37.

When shooting for a mixer output signal on 3.8–4.0 megacycles, VFO tuning ranges of either 2.2–2.4 megacycles (line 38) or 10.0–10.2 megacycles (line 39) present no stubborn problems. Careful alignment of the high "Q" tuned circuits following the mixer is necessary to prevent the second harmonic of the 2.2–2.4-megacycle VFO range from feeding through. A 7.2–7.3-megacycle mixer output signal may be obtained by combining the 6.2-megacycle SSB generator signal with either a 1.0–1.1-megacycle (line 40) or a 13.4–13.5-megacycle (line 41) VFO signal. However, as a 1.0–1.1-megacycle VFO is tuned through its range, the sixth harmonic signal will cross the SSB generator signal, and the seventh harmonic will cross the mixer output signal. Obviously, this combination is an excellent spurious output signal or "birdie" generator, so the 13.4–13.5-megacycle VFO signal is preferable.

The sum mixer output signals on both the 21.25- and 28.5-megacycle bands may be obtained with VFO tuning ranges of 15.05–15.25 (line 43) and 22.3–22.8 (line 44) megacycles, respectively. The only special precaution necessary with the signal combinations listed on lines 36 to 44 is a trap circuit to attenuate the fifth harmonic of the SSB generator signal on 31 megacycles, when operating the exciter on the 28.5-megacycle band.

DO IT YOURSELF SUGGESTIONS

Although other SSB generator signal frequencies may be used, choice of one of the following frequency ranges is suggested for the SSB generator when designing an all-band exciter with a minimum of spurious signals resulting from harmonics of the SSB generator signal: 6.2–6.5, 8.1–8.5, 11.7–12.7, 16.5–19.0, 23.5–25.5 and 33–45 megacycles.

What about a system in which the VFO signal is fed into a harmonic amplifier, and the resulting second, third, or fourth harmonic is used as the heterodyning signal in the mixer stage? This can lead to more complications from spurious signals than a double conversion system. In addition, it multiplies any VFO frequency drift by the same factor as the harmonic. Generally speaking, the double conversion system is preferable when a variable frequency mixer input signal higher than 10 megacycles is required to obtain a mixer output signal in the 7-, 21-, 28-, and 50-megacycle bands.

You can figure out your own SSB exciter signal frequency combinations by: (1) plotting the fundamental and harmonics of a tentative SSB generator frequency on graph paper; (2) plotting the VFO tuning ranges for obtaining output on each amateur band; and (3) filling in the harmonics of each VFO tuning range to see whether they fall within the feedthrough danger zone for the band on which the mixer output signal appears. If this happens, the SSB generator frequency may be shifted, then new VFO tuning ranges plotted which will miss the danger zones. Often, an SSB generator signal frequency may be found which permits the same VFO tuning range to be used on two bands. However, if you find a combination which produces a mixer output signal on **four** bands with only two VFO tuning ranges, then you've really hit the jackpot!

USING THE G-E 6AR8 SHEET BEAM TUBE

In Balanced Modulator, Synchronous Detector and Burst Gate Applications

DESCRIPTION AND RATING

The G-E 6AR8 sheet beam tube has attracted much attention for balanced modulator applications. It has the ability to perform mixing action of two input signals and cancel them in the output to provide an output signal equal to their sum or difference frequencies. Complete technical information is repeated on these pages, along with typical circuits in which radio amateurs have expressed an interest.

GENERAL

Cothode—Cooled Unipotential	
Heater Voltage, AC or DC	6.3 Volts
Heater Current	0.3 Amperes
Envelope—T-6½, Gloss	
Base—E9-1, Small Button 9-Pin	
Mounting Position—Any	
Direct Interelectrode Capacitances, approximate*	
Deflector-Number 1 to A11	4.8 μμf
Deflector-Number 2 to A11	4.8 μμf
Grid-Number 1 to A11 Except Plotes	7.5 μμf
Plote-Number 1 to A11	5.0 μμf
Plote-Number 2 to A11	5.0 μμf
Grid-Number 1 to Deflector-Number 1, maximum	0.040 μμf
Grid-Number 1 to Deflector-Number 2, maximum	0.060 μμf
Plote-Number 1 to Plote-Number 2	0.4 μμf
Deflector-Number 1 to Deflector-Number 2	0.38 μμf

MAXIMUM RATINGS

DESIGN-CENTER VALUES	
Plote-Number 1 Voltage	300 Volts
Plote-Number 2 Voltage	300 Volts
Accelerator Voltage	300 Volts
Peak Positive Deflector-Number 1 Voltage	150 Volts
Peak Negative Deflector-Number 1 Voltage	150 Volts
Peak Positive Deflector-Number 2 Voltage	150 Volts
Peak Negative Deflector-Number 2 Voltage	150 Volts
Positive DC Grid-Number 1 Voltage	0 Volts
Plote-Number 1 Dissipation	2.0 Watts
Plote-Number 2 Dissipation	2.0 Watts
DC Cothode Current	30 Milliamperes
Grid-Number 1 Circuit Resistance	
With Fixed Bios	0.1 Megohms
With Cothode Bios	0.25 Megohms

BASING DIAGRAM

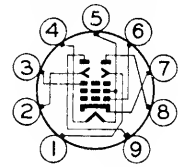

RETMA 9DP

BOTTOM VIEW

TERMINAL CONNECTIONS

- Pin 1—Deflector Number 2
- Pin 2—Deflector Number 1
- Pin 3—Accelerator
- Pin 4—Heater
- Pin 5—Heater, Internal Shield, and Focus Electrodes†
- Pin 6—Grid Number 1 (Control Grid)
- Pin 7—Cathode
- Pin 8—Plote Number 2
- Pin 9—Plote Number 1

PHYSICAL DIMENSIONS

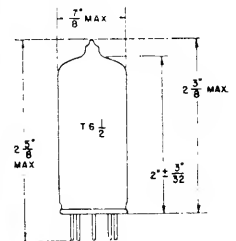

RETMA 6-3

CHARACTERISTICS AND TYPICAL OPERATION

AVERAGE CHARACTERISTICS WITH DEFLECTORS GROUNDED

Plate-Number 1 Voltage	250 Volts
Plate-Number 2, Connected to Plate-Number 1	
Accelerator Voltage	250 Volts
Deflector-Number 1 Voltage	0 Volts
Deflector-Number 2 Voltage	0 Volts
Cathode-Bias Resistor	300 Ohms
Total Plate Current	10 Milliamperes
Accelerator Current	0.4 Milliamperes
Grid-Number 1 Transconductance	4000 Micromhos
Grid-Number 1 Voltage, approximate	
I_b (total) = 10 Microamperes	-14 Volts

AVERAGE DEFLECTOR CHARACTERISTICS

Plate-Number 1 Voltage	250 Volts
Plate-Number 2 Voltage	250 Volts
Accelerator Voltage	250 Volts
Cathode-Bias Resistor	300 Ohms
Deflector Switching Voltage, maximum†	20 Volts
Deflector-Bias Voltage for Minimum Deflector Switching Voltage‡	-8 Volts
Voltage Difference between Deflectors for $I_{b1} = I_{b2}$, approximate	0 Volts
Plate-Number 1 Current, maximum	
$E_{d1} = -15$ Volts, $E_{d2} = +15$ Volts	1.0 Milliamperes
Plate-Number 2 Current, maximum	
$E_{d1} = +15$ Volts, $E_{d2} = -15$ Volts	1.0 Milliamperes
Deflector-Number 1 Current, maximum	
$E_{d1} = +25$ Volts, $E_{d2} = -25$ Volts	0.5 Milliamperes
Deflector-Number 2 Current, maximum	
$E_{d1} = -25$ Volts, $E_{d2} = +25$ Volts	0.5 Milliamperes

* Without external shield.

† Pin 5 should be connected directly to ground.

‡ Deflector switching voltage is defined as the total voltage change on either deflector with an equal and opposite change on the other deflector required to switch the plate current from one plate to the other.

Note: The 6AR8 should be so located in the receiver that it is not subjected to stray magnetic fields.

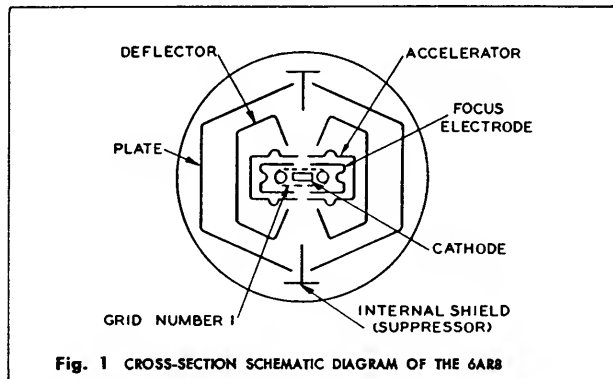

The tubes and arrangements disclosed herein may be covered by patents of General Electric Company or others. Neither the disclosure of any information herein nor the sale of tubes by General Electric Company conveys any license under patent claims covering combinations of tubes with other devices or elements. In the absence of an express written agreement to the contrary, General Electric Company assumes no liability for patent infringement arising out of any use of the tubes with other devices or elements by any purchaser of tubes or others.

OPERATING CONSIDERATIONS FOR THE 6AR8

A cross-section schematic diagram of the construction of the 6AR8 is shown. In this tube, the electrons pass from the cathode to either of the two plates in the form of a planar beam or "sheet." Before the electron stream emerges from the openings in the accelerator structure, it is acted on by the focus electrodes and the control grid. The focus electrode tends to converge the electrons into the required sheet beam, while the conventional grid-number 1 structure which surrounds the cathode serves to control the intensity of the beam.

Between the accelerator and the plates the electron beam passes between the deflector electrodes. Depending on the voltages applied to the deflectors, the beam will be directed entirely to either one or the other of the two plates or proportioned between them. The internal shield, located between the two plates, acts to suppress the interchange of secondary-emission electrons between the plates. The suppressor and the focus electrodes are internally connected to one side of the heater.

In normal operation, positive d-c voltages are applied to the accelerator and plates, and signal voltages are applied to the deflectors and control grid. The frequency of the signal applied to the deflectors determines the rate at which the plate current is switched between the two plates; the grid-number 1 voltage varies the magnitude of the plate current. The interesting tube characteristics which result from the unique construction of the 6AR8 are indicated by the average tube characteristic curves which follow. The tube may be considered as equivalent to a voltage-controlled single-pole double-throw switch through which a current, the magnitude of which is also voltage-controlled, flows.

If both plates and the accelerator are operated at +250 volts and a cathode-bias resistor of 300 ohms is employed, the deflectors require a peak switching voltage of 20 volts (or a peak voltage difference between deflectors of 40 volts) maximum to switch the plate current from one plate to the other. In a practical circuit, however, in which the deflectors are driven in push-pull with the center-tap of the source grounded, a somewhat higher value of deflector drive voltage must be used. The increased drive voltage is required to allow for those tubes in which the switching characteristics are somewhat offset with respect to zero voltage difference between deflectors.

For an accelerator voltage of +250 volts, the minimum deflector switching voltage occurs at a d-c deflector bias of approximately -8 volts; however, the d-c deflector bias is not particularly critical for focus as the deflection sensitivity characteristic exhibits a broad maximum. Care should be exercised, nevertheless, to assure that defocusing effects are not present whenever the tube is operated at conditions other than those recommended.

The circuit diagram for two 6AR8 tubes employed as synchronous detectors in a color television receiver is shown. In this arrangement, positive voltages are applied directly to the accelerator grids and through load resistors R₁, R₂, R₄ and R₅ to each of the plates. The chrominance signal is applied to the control grid of each tube. The 3.58-megacycle reference signal is applied in push-pull between the deflectors of each tube. The small coupling capacitor, C_c, between the tuned driving circuits provides the necessary 90-degree phase shift for the I and Q detectors. Also each tube is biased with a cathode resistor, R₃ and R₆; resistor R₆ is variable so that the relative gains of the two demodulators can be adjusted.

In principle, the 6AR8 circuit is a product-demodulator type of synchronous detector; however, because the circuit uses a double-plate sheet-beam tube rather than a dual-control pentode or heptode, certain significant operating features result. First the 6AR8 circuit is capable of delivering relatively large and balanced output voltages which exhibit good linearity. Because output voltages are available of both positive and negative polarities, the need for the incorporation of phase-inverter circuits in the matrix section of the color receiver is completely eliminated. Also, providing the oscillator reference voltage is adequate to switch the plate currents between the two plates, the circuit is insensitive to variations in the amplitude of the oscillator voltage over a wide range. Furthermore, unlike the pentode or heptode synchronous detector circuits in which the third grid is driven positive by the oscillator reference voltage, the deflectors of the 6AR8 require very little excitation power. Consequently, less power is required from the 3.85-megacycle reference oscillator in the sheet-beam tube circuit.

Another feature is that space-charge coupling effects, which are inherently present in dual-control pentodes and heptodes, are unnoticeable in the 6AR8. Also, unlike most dual-control pentodes and heptodes in which the screen current is an appreciable percent of the plate current, the accelerator current of the 6AR8 is less than one-twentieth of its plate current.

✦ R. Adler and C. Heuer, "Color Decoder Simplifications Based on a Beam-Deflection Tube," Trans. IRE, PGBTR-5, Jan. 1954.

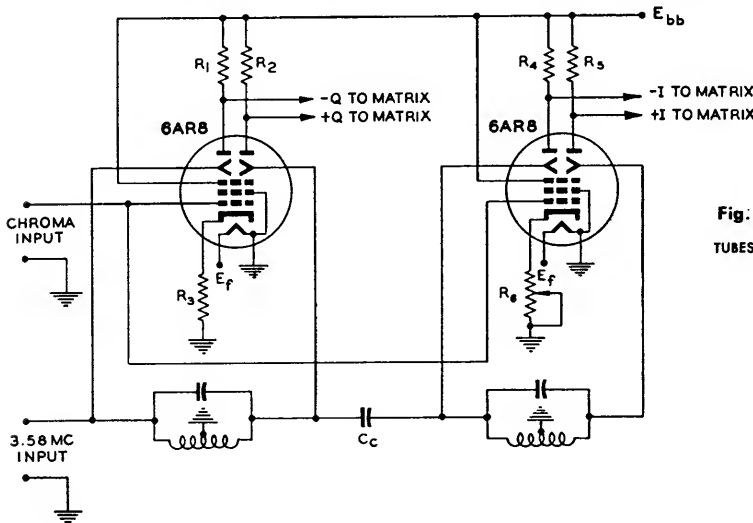

Fig. 2 CIRCUIT DIAGRAM OF TWO 6AR8 TUBES USED AS SYNCHRONOUS DETECTORS

TYPICAL CIRCUITS USING THE G-E 6AR8

The G-E 6AR8 sheet beam tube is, by its very nature, suited for a number of circuit applications in amateur radio single sideband transmitting and receiving equipment. The following circuits illustrate these applications.

Component values as shown will provide normal performance of these circuits in most cases. However, in certain instances, the values of cathode resistances may require lowering to obtain optimum circuit performance. Also, shielding and other r. f. constructional practices, have not been shown.

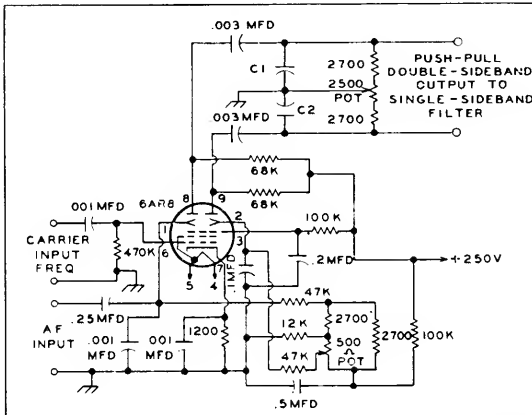

Fig. 3 Suggested circuit for a balanced modulator using the 6AR8 sheet beam tube with the audio signal applied to one beam deflecting plate, and the r.f. signal to be modulated applied to the control grid. All resistances are in ohms, 1/2 watt unless otherwise specified. "K" equals 1,000. Capacitance values are in microfarads (mfd), except where specified. Capacitors C₁ and C₂ should be equal in value, with a total series capacitance of the proper value to resonate the input side of the sideband filter at the operating frequency.

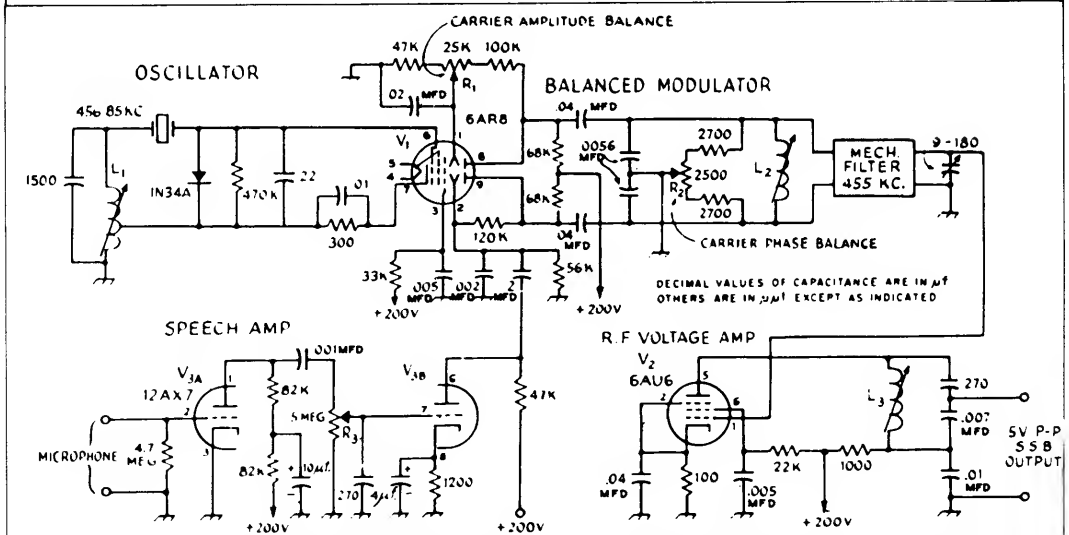

Fig. 4 Suggested schematic diagram of a simplified filter-type single sideband generator operating at 455 kilocycles. The G-E 6AR8 sheet beam tube combines the functions of carrier oscillator, and balanced modulator. The output from the 6AR8 plates is a double sideband, suppressed carrier signal. One sideband is removed after passage through the bandpass filter at the right. All resistances are in ohms, 1/2 watt rating unless specified. Potentiometers R₁, R₂ and R₃ have composition elements. Capacitances are in micro-microfarads, unless value is specified in microfarads (mfd). Capacitors with polarized markings are electrolytic types.

Fig. 5. Suggested schematic diagram of a G-E 6AR8 sheet beam tube operating as a combined tunable oscillator (VFO) and mixer. Circuit values are shown for a tunable oscillator operating at 3.3 to 3.6 megacycles, with a 455-kilocycle SSB signal applied to one beam deflection plate. The sum of the two input frequencies appears in the output circuit, T_1 , tuned to the 3.8 to 4.0-megacycle range. The oscillator coil, L_4 , has an inductance of 4.7 microhenries. It was wound on a 3/4-inch diameter ceramic coil form, with 21 turns of No. 20 enameled wire spacewound 1 inch long. The cathode tap is 3 turns, and the grid tap 10 turns, from the grounded end.

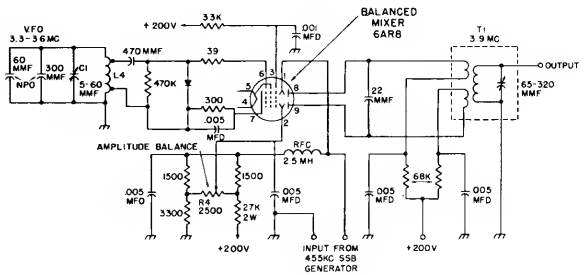

Fig. 6 Suggested schematic diagram for a 6AR8 tube in a balanced mixer circuit. This circuit is suitable for combining two input signals from a SSB generator and tunable oscillator (VFO), and obtaining either the sum or difference signal in the tuned output circuit, C_1 -- L_1 . Conventional tuned circuits may be used here, and in T_1 . All resistances are in ohms, 1/2 watt, unless specified. Capacitances are in microfarads (mfd). A linear taper composition potentiometer should be used for R_1 .

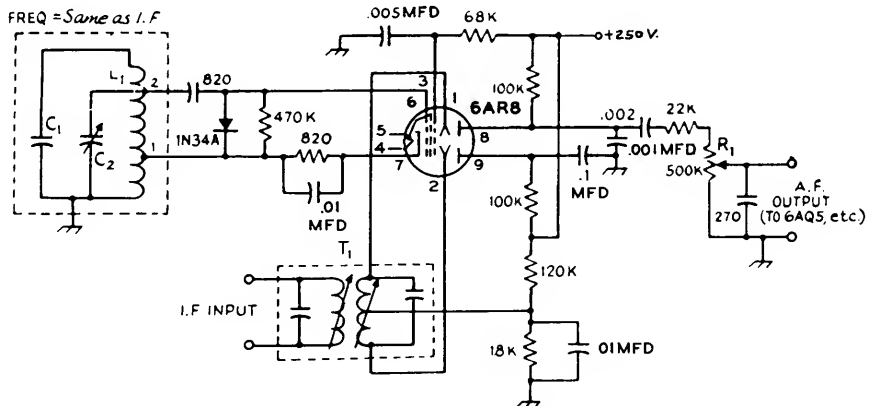
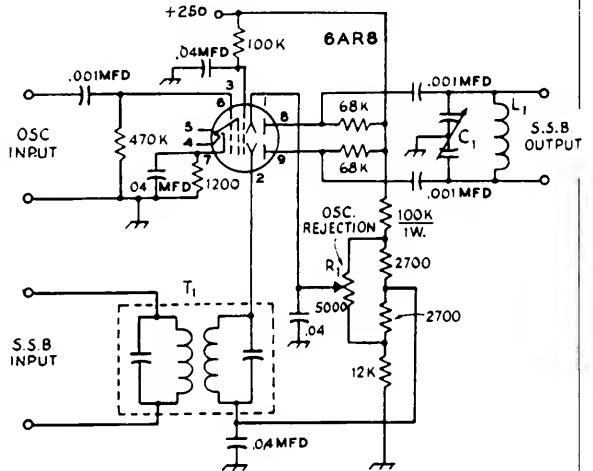

Fig. 7. Suggested circuit for a 1-tube product detector using the G-E 6AR8 sheet beam tube. The circuit contains its own carrier oscillator utilizing the cathode, control grid and number three grid elements. The beam deflecting plates are in the detection circuit, and the audio output signal is taken from the plates. The oscillator tuned circuit should have high capacitance for best stability. Taps 1 and 2 on L_1 should be about 5 and 25 percent, respectively, from the grounded end. Resistances are in ohms, 1/2-watt rating. Capacitances in decimals are in microfarads (mfd); those in whole numbers are in micro-microfarads (mmf).

BALANCED MODULATORS

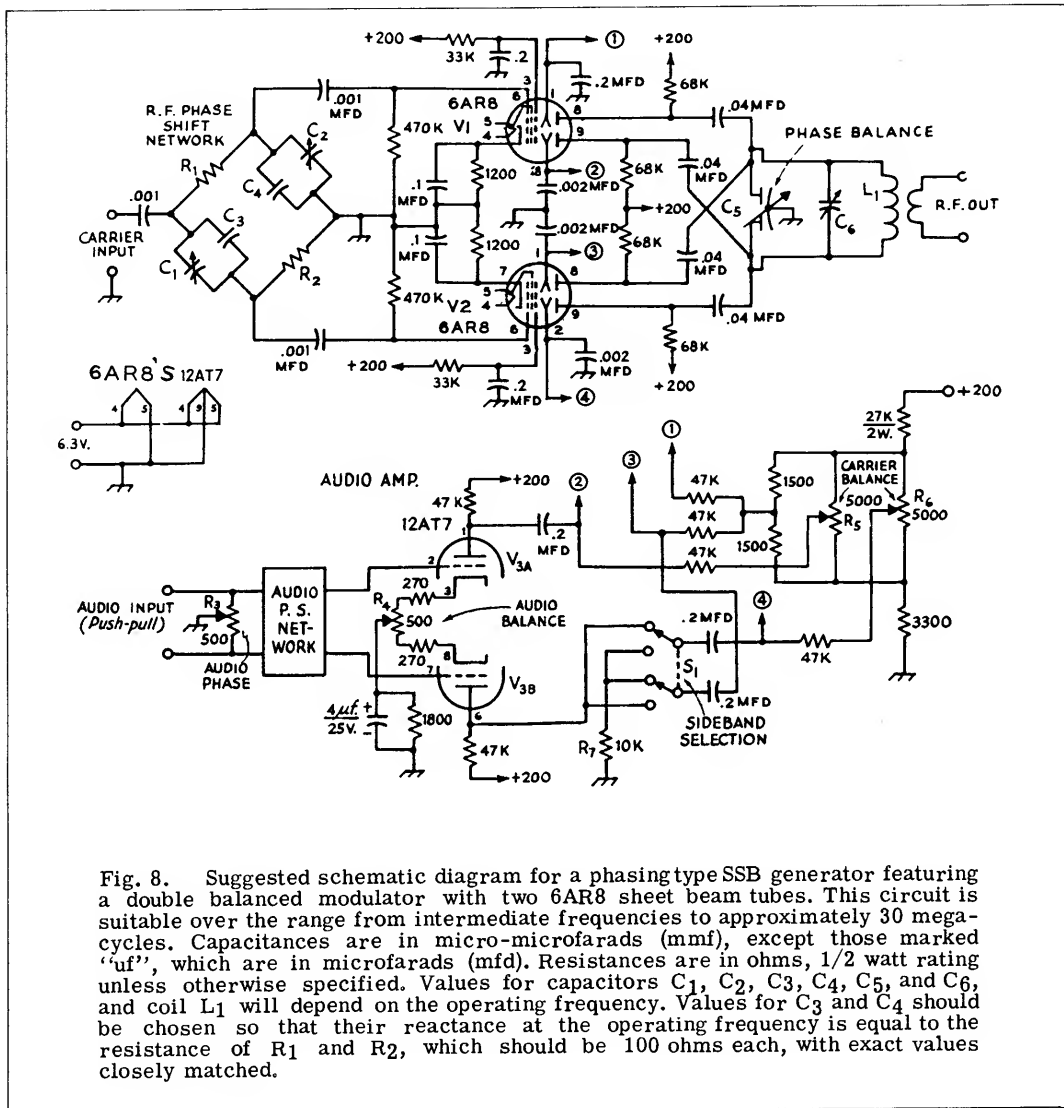

Fig. 8. Suggested schematic diagram for a phasing-type SSB generator featuring a double balanced modulator with two 6AR8 sheet beam tubes. This circuit is suitable over the range from intermediate frequencies to approximately 30 megacycles. Capacitances are in micro-microfarads (mmf), except those marked "uf", which are in microfarads (mfd). Resistances are in ohms, 1/2 watt rating unless otherwise specified. Values for capacitors C₁, C₂, C₃, C₄, C₅, and C₆, and coil L₁ will depend on the operating frequency. Values for C₃ and C₄ should be chosen so that their reactance at the operating frequency is equal to the resistance of R₁ and R₂, which should be 100 ohms each, with exact values closely matched.

A SSB exciter construction article with the 6AR8 as a balanced modulator was described in the July, 1956 issue of CQ, on pages 24 to 31. This filter type exciter was designed and constructed by William I. Orr, W6SAI.

Additional material on applications of sheet beam receiving tubes has been published in the March, 1960 issue of QST magazine.

A new article showing the G-E 6AR8 as a balanced modulator in a simple double sideband transmitter, reconstructed from a surplus Command Set transmitter, appears in the May, 1961 issue of CQ magazine, on pages 48 through 51.

A new type of miniature sheet beam tube which has low output capacitances, and thus is capable of operating in balanced modulator circuits well into the VHF region, has just been announced by the General Electric Receiving Tube Department. It is known as the 7763 and will appear in G-E HAM NEWS articles during 1962.

SIDEBAND GENERATORS AND EXCITERS

SSB, JR.

From November-
December, 1950

Presenting a 3-Tube, 5-Watt
SSB Transmitter
with Superior Performance



Fig. 1. Front panel view of the SSB Jr. For single-frequency operation none of the controls need be adjusted (except the audio gain control). Front-panel mounting of the controls permits a compact physical layout to be obtained.

FEATURES—

- Simple to construct
- Uses inexpensive parts
- Has sideband-reversing control
- Usable as emergency, portable or home transmitter

The SSB Jr. is a complete single-sideband transmitter—just add microphone and antenna and you are on the air. No longer must amateurs feel that single-sideband equipment is too complex to under-

stand or too complicated to build. The SSB Jr. rig is no more difficult to build or adjust than any modern 3-tube transmitter. This rig should bring SSB within the reach of anyone that is interested.

SSB, Jr.

ELECTRICAL CIRCUIT

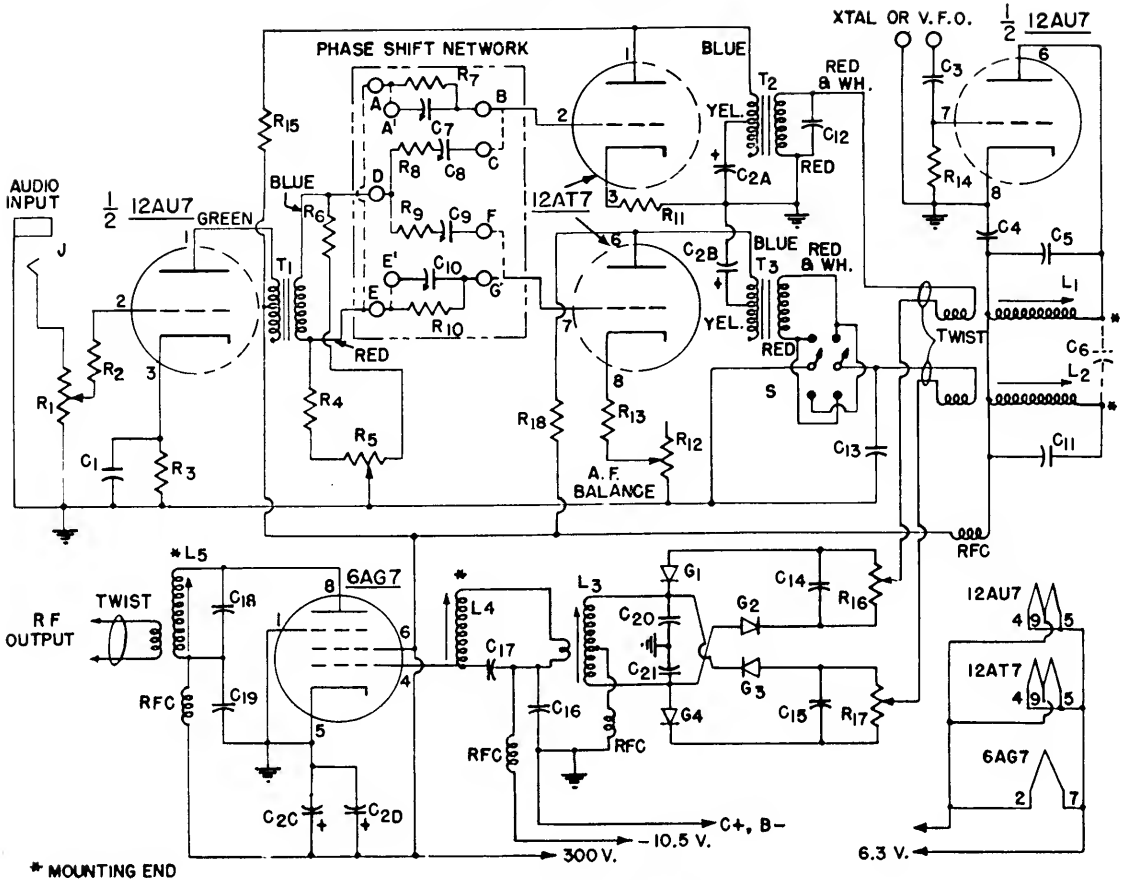

Fig. 2. Circuit diagram of the SSB Jr.

Circuit Constants

(All resistors and capacitors $\pm 20\%$ tolerance unless specified otherwise)

C ₁	0.5 mf 200 volt paper
C ₂	20-20-20-20 mf 450 volt electrolytic
C ₃ , C ₄ , C ₁₂ , C ₁₃ , C ₁₆	1000 mmf mica or ceramic
C ₅ , C ₁₁ , C ₁₇	250 mmf mica $\pm 10\%$
C ₆	May not be necessary, see text
C ₇	2430 mmf (0.002 mf mica $\pm 5\%$ with 170-780 mmf trimmer in parallel)
C ₈	4860 mmf (0.0043 mf mica $\pm 5\%$ with 170-780 mmf trimmer in parallel)
C ₉	1215 mmf (0.001 mf mica $\pm 5\%$ with 50-380 mmf trimmer in parallel)
C ₁₀	607.5 mmf (500 mmf mica $\pm 10\%$ with 9-180 mmf trimmer in parallel)
C ₁₄ , C ₁₅	0.005 mf mica or ceramic
C ₁₈	350 mmf 600 volt mica $\pm 10\%$ (250 mmf in parallel with 100 mf)
C ₁₉	0.01 mf mica or ceramic
C ₂₀ , C ₂₁	0.002 mf mica $\pm 10\%$
G ₁ , G ₂ , G ₃ , G ₄	1N52 germanium diode or equivalent, see text
J.....	Open circuit jack
L ₁ , L ₂	33 turns No. 21 enamel wire close wound on Millen No. 69046 iron core adjustable slug coil form. Link of 6 turns of hookup wire wound on open end.

L ₃	16 turns No. 19 enamel wire spaced to fill Millen No. 69046 coil form. Tap at 8 turns. Link of 1 turn at center.
L ₄	Same as L ₁ except no link used
L ₅	28 turns No. 19 enamel wire. Link on open end to match load. (4 turn link matches 72 ohm load.)
RFC.....	Radio-frequency choke 0.5 millihenry
R ₁	1 megohm potentiometer
R ₂	10,000 ohm, $\frac{1}{2}$ watt
R ₃	750 ohm, $\frac{1}{2}$ watt
R ₄	430 ohm, $\frac{1}{2}$ watt ($\pm 5\%$)
R ₅	100 ohm potentiometer
R ₆	1600 ohm, $\frac{1}{2}$ watt ($\pm 5\%$)
R ₇ , R ₁₀	133,300 ohm, $\frac{1}{2}$ watt ($\pm 1\%$)
R ₈ , R ₉	100,000 ohm, $\frac{1}{2}$ watt ($\pm 1\%$)
R ₁₁	510 ohm, $\frac{1}{2}$ watt ($\pm 5\%$)
R ₁₂	500 ohm potentiometer
R ₁₃	330 ohm, $\frac{1}{2}$ watt
R ₁₄	47,000 ohm, $\frac{1}{2}$ watt
R ₁₅ , R ₁₈	20,000 ohm, 1 watt
R ₁₆ , R ₁₇	1000 ohm potentiometer
S.....	DPDT toggle switch
T ₁	Stancor A-53C transformer
T ₂ , T ₃	UTC R-38A transformer

Further, any amateur can build the SSB Jr. rig and be assured that his single-sideband signal will be second to none in quality. Performance has not been sacrificed in the interest of simplification.

The peak power output is 5 watts and the total power input, not including filament power, is 18 watts (300 volts at 60 ma.). The SSB Jr. rig features a self-contained crystal oscillator (or buffer for VFO operation), 40 db. sideband suppression, and mechanical and electrical ruggedness that make it ideally suited as a complete portable, mobile, emergency transmitter, or as an exciter for a home transmitter.

The system used in the generation of the single-sideband signal is a simplified phasing method that is daringly direct and effective. Inexpensive and easily-available components are used throughout.

All of the information necessary to construct and adjust the SSB Jr. rig appears in this article. Technical details on the new phase-shift network and the new modulator design are explained in the Designer's Corner section of this issue.

Circuit Description

With reference to the circuit diagram, Fig. 2, the first tube, a 12AU7, is a twin-triode, combination speech amplifier oscillator. A 12AT7 serves as a twin-channel amplifier in the output of the phase-shift network, and the final is a 6AG7 pentode.

Starting with the audio circuit, an input gain control potentiometer feeds the grid of the self-biased input tube, which is one-half of the 12AU7 miniature tube. The output of this tube is coupled into a newly designed audio phase-shift network by means of transformer T_1 . The outputs of the phase-shift network feed separate triode sections of the 12AT7 miniature tube. These two tube sections are transformer coupled to two balanced modulators each of which employs a pair of germanium crystal diodes.

The balanced modulators are also supplied by r-f signals from the crystal oscillator, which is the other half of the 12AU7. These r-f signals are picked up by separate link windings on L_1 and L_2 , which comprise portions of a 90 degree r-f phase-shift network in the plate circuit of the oscillator. The balanced modulators work into a balanced load circuit (L_3 , C_{21} , C_{21}) which is link coupled to the grid circuit (L_4 , C_{17}) of the class AB_1 linear power amplifier tube, a 6AG7.

This power amplifier works into a conventional tank circuit (L_5 , C_{18}) that is link coupled to the load. All circuit tuning is accomplished by adjustable slug-tuned coils wound on Millen No. 69046 powdered-iron coil forms.

Sideband switching is accomplished by the reversal of audio polarity in one of the audio channels (switch S). Provision is made for equalization of gain in the audio channels, this equalization being necessary in order to achieve normal sideband cancellation. In addition, a semi-fixed control (R_1) is provided for phase-shift network adjustment. Use of this control eliminates the need for a special transformer, or the need for two non-standard precision resistors. Stable modulator balance is achieved by the balance/buffer resistors R_{15} and R_{17} in conjunction with the germanium diodes.

The audio characteristic of the SSB Jr. is designed to emphasize the intelligence-bearing frequencies from 300 to 3000 cycles per second. This feature is obtained jointly by the action of C_1 and the audio transformer T_1 . Low differential phase-shift is maintained in audio circuits following the phase-shift network by means of lightly loaded output transformers which are shunt-fed to reduce harmonic distortion caused by direct current in their windings.

A 5 by 7 by 2 inch chassis provides ample space, with good access, for all component parts. A cabinet, as shown, may be used, although this is not essential. It is recommended that parts layout shown in the sketches and the photographs be followed exactly. Obviously other layouts will work, but the layout shown has been carefully made and many layout problems have been eliminated.

Before starting work on the main chassis it is advisable to make the audio phase-shift network board. This is diagrammed in Fig. 3. The base material may be thin bakelite or any insulating material. The dimensions are 4 inches by $2\frac{1}{8}$ inches. Note that one corner is cut off to permit access to the 12AU7 tube. This board uses four fixed mica condensers which are padded with four adjustable mica trimmers, and four precision resistors (Continental Nobleloy X- $\frac{1}{2}$, plus or minus 1% tolerance). In the unit shown R_8 and R_9 are as specified, that is, they are Continental Nobleloy 100,000 ohm resistors. However, the 133,300 ohm resistors were made by taking two 150,000 ohm precision Continental Nobleloy resistors and paralleling each of them with a one-half watt 1.2 megohm (plus or minus 10% tolerance) resistor. Careful selection of the 1.2 megohm units will permit close adjustment to the desired value of 133,300 ohms. A convenient way to mount the 1.2 megohm resistors is to slip them inside the hollow body of the precision 150,000 ohm resistors.

The phase-shift network sub-assembly is mounted on three half-inch long spacers under the chassis directly below transformers T_1 and T_2 . It is best to dress the leads from these transformers flat against the chassis to clear the phase-shift network. Time will be saved by installing the network sub-assembly as the last step in the construction.

Mount the phase-shift network elements as shown in Figs. 3A and 3B. The dashed connections should be omitted initially, since the detailed alignment procedure described later presumes that these connections will be made at the proper time only.

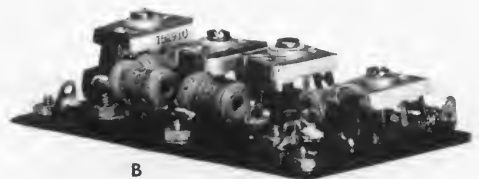
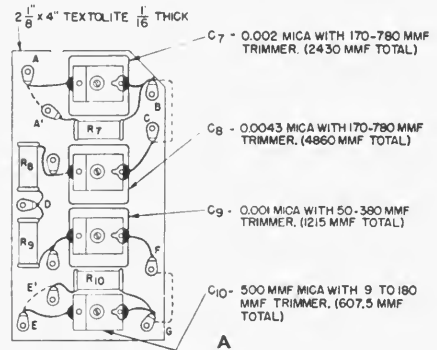

Fig. 3. (A) Mechanical arrangement of the audio phase-shift network. (B) Detail view of the audio phase-shift network

A word of caution about the coils. Make sure that the hot and cold ends are as specified on the circuit diagram—the asterisk indicates the end which is the mounting end, that is, the end with the long tuning screw.

The links on the coils are wound over the cold end, as indicated in Fig. 11. As a suggestion, wind the links with solid insulated hookup wire. This type of wire is convenient, holds on well, and makes a nice looking job. Twist the wires together when running from one coil to another coil, or to another connection point. A small terminal strip may be placed under L_1 to serve as a convenient junction point for the links coming from L_1 and L_2 and going to the balanced modulators.

The small fixed mica tuning condensers that connect across L_1 , L_2 and L_3 are mounted on the coil form terminals. The coupling capacitor between L_1 and L_2 (C_6) is shown dotted in the circuit diagram, since the amount of actual capacitance needed at this point will depend on stray coupling effects in the particular unit you build. More information will be given on this later.

Note that the grid connection of the 6AG7 is above the panel from the hot end of L_4 through a hole in the chassis right next to pin number 4 (the grid terminal) of the 6AG7 socket. Direct strapping of terminals 1, 3 and 5 of this socket to the chassis is desirable to ensure stable amplifier operation. Note also that a 2 by 2 $\frac{1}{2}$ inch brass or aluminum shield is placed between coils L_2 and L_3 below deck.

The unused transformer leads may be cut off close to the winding and forgotten. The secondary windings of T_2 and T_3 have several intermediate taps that are not used. All leads from the three transformers are fed through small rubber grommets in the chassis to circuits on the underside. All, that is, except the secondary leads from T_3 which remain above chassis. Twist these leads together before running them to the sideband reversing switch on the front panel.

Do not ground either heater lead in the chassis, as you may wish to use an a-c heater power supply or perhaps run your automobile engine while transmitting if the rig is used for mobile work.

Ample mounting space for C_1 and R_3 will be found near C_2 , the four-section electrolytic condenser. With reference to C_2 , one 20 mf section is C_{2A} , another is C_{2B} , etc. The heater leads that run from the 12AU7 may be cabled together with the other leads from T_1 , T_2 , T_3 .

The germanium diodes deserve special care in handling. Do not bend the leads close to the diode unit itself. The diodes are mounted by means of their leads between the coil terminals of L_3 and the appropriate ends of R_{16} and R_{17} . Protect the germanium diodes from heat while soldering by holding the lead with cold pliers between the diode itself and the end where the soldering is taking place. Further, use only as much heat as is necessary to make a good joint.

A four-wire shielded cable brings power from the power supply to the exciter. The shield serves as the negative plate supply lead and should be connected to chassis ground. A male plug at the other end of the cable makes a convenient connection to the power supply.

Power Supply Construction

The power supply is not unusual in any respect. Any source of power supplying 300 volts and 60 mils or more may be used. It is not necessary to use electronic bias either, and a standard battery supplying 10.5 volts may be used for bias.

The power supply used with the SSB Jr. rig pictured is shown in Fig. 7 and the circuit diagram given in Fig. 6. A 5V4-G rectifier tube feeds a single-section filter to supply 300 volts, and a 6H6 tube acts as a bias rectifier to supply 10.5 volts. Resistor R_1 adjusts the bias voltage obtainable.

The main a-c switch is S_1 , and the stand-by switch is S_2 . Note that resistor R_2 acts as a low resistance bleeder to drop the positive voltage to zero quickly when the rig is turned off. A double-pole switch is employed with the switch arms tied together, as this arrangement gives the effect of a double break contact.

There is nothing critical about the power supply layout, and any arrangement may be used to suit your convenience.

Microphone Considerations

The SSB Jr. rig as designed requires that a high-output microphone circuit be used. A single-button carbon microphone, connected as shown in Fig. 8B is quite adequate, even desirable, if mobile operation is contemplated.

On the other hand, low-level microphones, such as the usual type of crystal or dynamic microphone, may be used if a one-tube preamplifier is provided. A suggested circuit is shown in Fig. 8A. This preamplifier may be built as a separate unit or incorporated into the SSB Jr. rig. Either the preamplifier shown or the single-button carbon mike circuit will provide in excess of the 2 volt (RMS) signal level required as a minimum input signal to the SSB Jr.

Component Parts

As is true with many transmitter designs, there are some component parts used in the SSB Jr. rig that must be chosen carefully. Obviously, the precision resistors specified are important. If precision resistors are not available—although you should try to get them if at all possible—you may use non-precision resistors which have been checked on a good resistance bridge. You may find that these resistors will change value after they have been used for a while, and that is why it is desirable to use precision resistors initially.

The adjustable mica trimmers used in the audio phase-shift network may be any good grade of mica trimmer. Those actually used are El-Menco mica trimmers—T52910 for the 170 to 780 mmf range; T52510 for the 50 to 380 mmf range; and T52310 for the 9 to 180 mmf range.

Resistors R_4 , R_6 and R_{11} are specified as plus or minus 5% tolerance. This is because the values stated are required, and these values only come in the 5% tolerance series.

The germanium diodes are specified as 1N52 diodes. Other types, such as 1N48, 1N51 and 1N63 may be used instead. If possible, select four diodes which have about the same forward resistance. The forward resistance is the low resistance as checked on an ohmmeter. To determine approximately what it is, measure the resistance in one direction, then reverse the leads to the diode and make a second measurement. The two readings should be quite different. The lower resistance is the one of interest. Make this measurement on the four diodes you intend to use to make sure that the forward resistance of any one of the diodes is within ten per cent of the average resistance of the group.

The diodes used in the rig shown measured approximately 250 ohms on a Weston 772 analyzer when the analyzer was set to the RX10 scale. (Dif-



Fig. 4. Rear view of the SSB Jr.

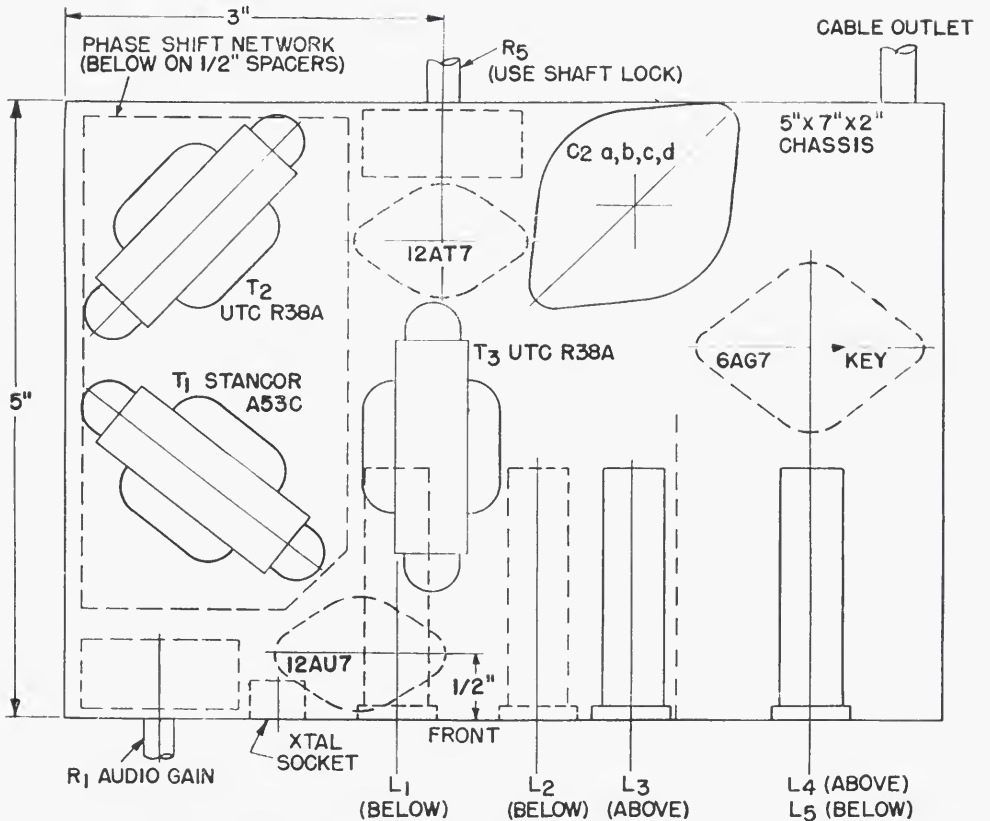

Fig. 5. Chassis layout for the SSB Jr. (top view)

ELECTRICAL CIRCUIT

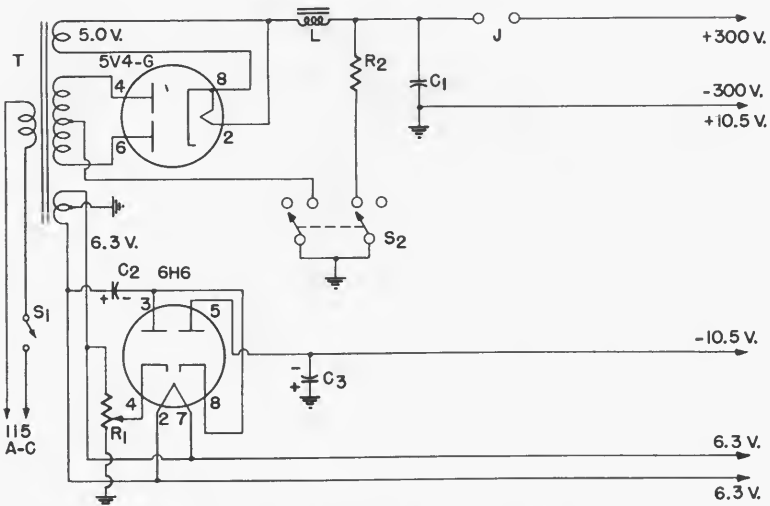

Fig. 6. Circuit diagram of the SSB Jr. power supply

Circuit Constants

(All resistors and capacitors = 20% tolerance unless specified otherwise)

C₁ 40 mf 450 volt electrolytic
 C₂, C₃ 50 mf 50 volt electrolytic
 J Closed circuit jack or terminal posts to permit metering with 0-100 mil meter
 L 7 henry choke, 160 mils (UTC R-20)
 R₁ 100 ohm potentiometer

R₂ 1000 ohm 1 watt
 S₁ SPST toggle switch
 S₂ DPDT toggle switch
 T Power transformer, 350-0-350 at 75 mils, 6.3 volts at 3 amperes, 5.0 volts at 3 amperes (UTC R-11)

ferent ohmmeters may give different readings, since the diodes are non-linear in nature.)

It is recommended that transformers T₁, T₂ and T₃ be as specified. Do not make any substitution unless you wish to duplicate a long series of tests to determine if the substitutes are suitable. The types indicated are standard parts, inexpensive, and easy to procure. Observe that the connections are indicated on the circuit diagram by their color code.

It is further recommended that you use Millen No. 69046 coil forms as specified. While the coils are not critical, they must have a certain inductance and distributed capacitance, and if you adhere to the specifications given you should encounter absolutely no difficulty coil-wise.

Initial Circuit Adjustments



Fig. 7. SSB Jr. Power supply

The adjustment of the audio phase-shift network circuits is most easily done with the phase-shift sub-assembly out of the chassis. The resistors R₇ and R₈ (and R₁₀ and R₉) should bear the ratio of 133,333 to 100,000, that is, 4 to 3, as closely as can be determined. If in doubt as to the ratio of the resistors you used, double-check their value on an accurate bridge. The adjustment of the phase-shift network now consists only of setting the four capacitors (C₇ through C₁₀) to their proper values. Several methods can be used. The most accurate will be described.

An audio oscillator capable of operation from 225 to 2750 cycles per second (with good waveform) is required, plus an oscilloscope. The oscillator should be carefully calibrated by the method described later. Connect the output of the audio oscillator through a step-down transformer (the Stancor A-53C will serve nicely) to a 1000 ohm or 2000 ohm potentiometer with the arm grounded.

Adjust the arm position so that equal (but opposite) voltages appear on each half of the potentiometer. A steady audio frequency signal of any convenient frequency may be used with an oscilloscope acting as a convenient voltmeter for this job. Swing the vertical deflection lead from one end of the potentiometer to the other and adjust the arm to obtain equal voltages (a true center tap). Set up a temporary double cathode-follower circuit using a 12AT7 with 500 ohms from each cathode to ground and connect as shown in Fig. 9. (It will be convenient to provide leads M, N, and 1 and 2 with clips at the ends to facilitate checking.) One may use the 12AT7 in the rig as the double cathode follower by temporarily short circuiting the plate of each tube to its respective center tap of the UTC R-38A transformers. Be sure to remove the 12AU7 and the 6AG7 at this time, and of course supply operating voltages for the

ELECTRICAL CIRCUIT

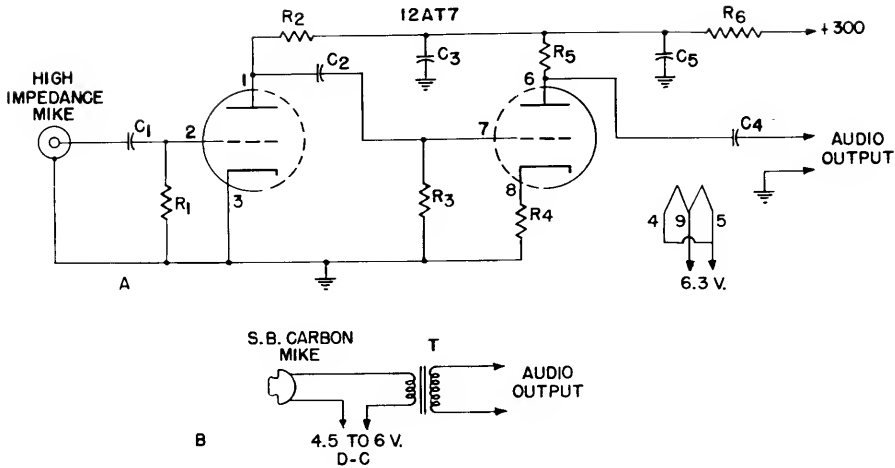

Fig. 8. Suggested microphone circuits for use with the SSB Jr.

Circuit Constants

(All resistors and capacitors $\pm 20\%$ tolerance unless specified otherwise)

C ₁ , C ₂ , C ₄	0.05 mf 400 volt paper	R ₁	470 ohm, ½ watt
C ₃ , C ₅	8 mf 450 volt electrolytic	R ₂	47,000 ohm, ½ watt
R ₁	2 megohm, ½ watt	R ₃	33,000 ohm, ½ watt
R ₂	0.1 megohm, 1 watt	T.....	Microphone to grid transformer
R ₃	0.5 megohm, ½ watt		

12AT7. Pins 3 and 8 should connect to the H and V deflection amplifiers in the oscilloscope, and the oscilloscope common connection should be made to the chassis.

First connect lead M to terminal A on the phase-shifter unit, and lead N to terminal A'. Connect leads 1 and 2 to terminal M. (Note that the dashed connections are missing at this stage of adjustment.) Adjust the horizontal and vertical gains on the oscilloscope to produce a line about 1½ inches long slanted at 45 degrees when the oscillator is set to a frequency of 490 CPS (an exact method of setting frequency will be described later). If the oscilloscope has negligible internal phase shift the display will be a straight line instead of a narrow slanting ellipse. If the latter display appears it is necessary to correct the oscilloscope phase shift externally by using an adjustable series resistance (a 50,000 ohm potentiometer) mounted at either the vertical or horizontal input terminal, depending on what correction is necessary.

At any rate, the objective here is to get a single straight line at 490 CPS. In some cases a series capacitor may be needed to provide the necessary correction. Try values from 0.05 to 0.0005 mf. Now shift lead 1 from terminal A to terminal B on the phase shifter. Adjust the trimmer of C₇ to obtain a circle on the oscilloscope. It will be noted that as this adjustment is made the display will shift from an ellipse "leaning" to one side through a circle or ellipse (with axes parallel to the deflection axes) to an ellipse which leans the other way. If desired or necessary, the appropriate gain control on the oscilloscope may be changed so that a circle instead of a "right" ellipse is obtained at the point of correct adjustment. After changing the gain control on the oscilloscope, check (and correct, if necessary) the phase shift in the oscilloscope by moving lead 1 back to terminal

A, and then repeat the setting of C₇ with lead 1 back on terminal B.

In general, always make certain that the oscilloscope is used in a phase-corrected manner. As a double-check (if the deflection plates in the oscilloscope are skewed, for instance) connect lead 2 to terminal A'. If the circle changes to a slanting ellipse, readjust C₇ to produce an ellipse "half-way" between the ellipse (obtained by switching lead 2) and a circle. Changing lead 2 from A' to A and back again should give equal and opposite skew to the display when C₇ is set correctly. Failure to get symmetrical ellipses (egg-shaped, or other display) is due to distortion, either in the oscilloscope, the oscillator, the transformer, or the cathode follower. Conduct the test at as low a signal level as possible to avoid distortion.

Next connect leads M and N to terminals E and E', respectively. Connect leads 1 and 2 to E, set the oscillator frequency to 1960 CPS, correct oscilloscope phase shift as before, and move lead 1 to terminal G. Adjust C₁₀ for a circle as was done for C₇, using the precautions outlined for that case.

Now connect lead M to terminal D, and lead N to terminal F. Connect leads 1 and 2 to terminal D, set the oscillator frequency at 1307 CPS, correct oscilloscope phase shift as before, and move lead 1 to the junction of R₅ and C₅. Adjust C₉ for a circle on the oscilloscope, as before.

Repeat the above procedure for the remaining R-C pair, R₄ and C₃. Use terminals D and C this time and set the oscillator for 326.7 CPS. This completes except for a final check the adjustment of the phase-shifter network. Connect A to A', E to E', B to C, F to G, and A to E. Be certain to remove the temporary short circuiting connections between the 12AT7 plates and T₂, T₃.

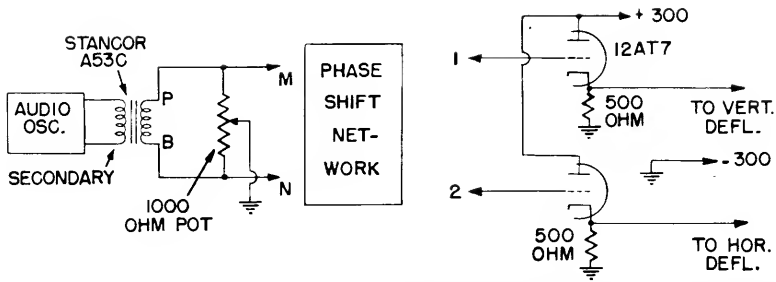

Fig. 9. Audio phase-shift network test layout

If the oscilloscope did not require changes in external compensation over the four frequencies used an over-all frequency check can now be made easily on the phase-shift network. To do this, connect lead 1 to point B, C, lead 2 to point F, G, lead M to point A, A', E, E', and lead N to point D. Now shift the arm of the potentiometer toward M until a circle appears on the oscilloscope screen at a frequency of 250 CPS. Then, as the oscillator frequency is varied from 250 CPS to 2500 CPS, this circle will wobble a little from one side to the other, passing through a perfect circular display at 440, 1225 and 2500 CPS.

The audio band over which the wobble indicates a plus or minus 1.3 degree deviation from 90 degrees is 225 to 2750 CPS, or 12 to 1 in range. This means that when other circuits are properly adjusted, a sideband suppression ratio of 39 db is possible at the *worst* points within this range. The average suppression ratio will be about +5 db. Proper phase-shift network operation is necessary to obtain this class of performance, so the adjustment procedures have been explained in great detail as an aid toward this goal. The phase shift network should never require read-

justment, so that when you are satisfied with the adjustment you may seal the trimmers with cement.

Audio Oscillator Calibration

It will be noted that the frequency ratios are such that the 12th harmonic of 326.7 CPS, the 8th harmonic of 490 CPS and the 3rd harmonic of 1306.7 CPS are all the same as the 2nd harmonic of 1960 CPS, namely, 3920 CPS. Thus, if a stable source of 3920 CPS frequency (such as a thoroughly warm audio oscillator) be used as a reference, the frequency of the test oscillator can be set very closely to one-half, one-third, etc., of this reference frequency if both oscillators feed an oscilloscope and the resulting Lissajous figures observed.

Use of a calibrating frequency in this manner assures that the frequency *ratios* used are correct, even though the exact frequencies used are unknown. The frequency ratios (just as the resistance ratio previously mentioned) are far more important than the actual values of frequency (or resistance) used.

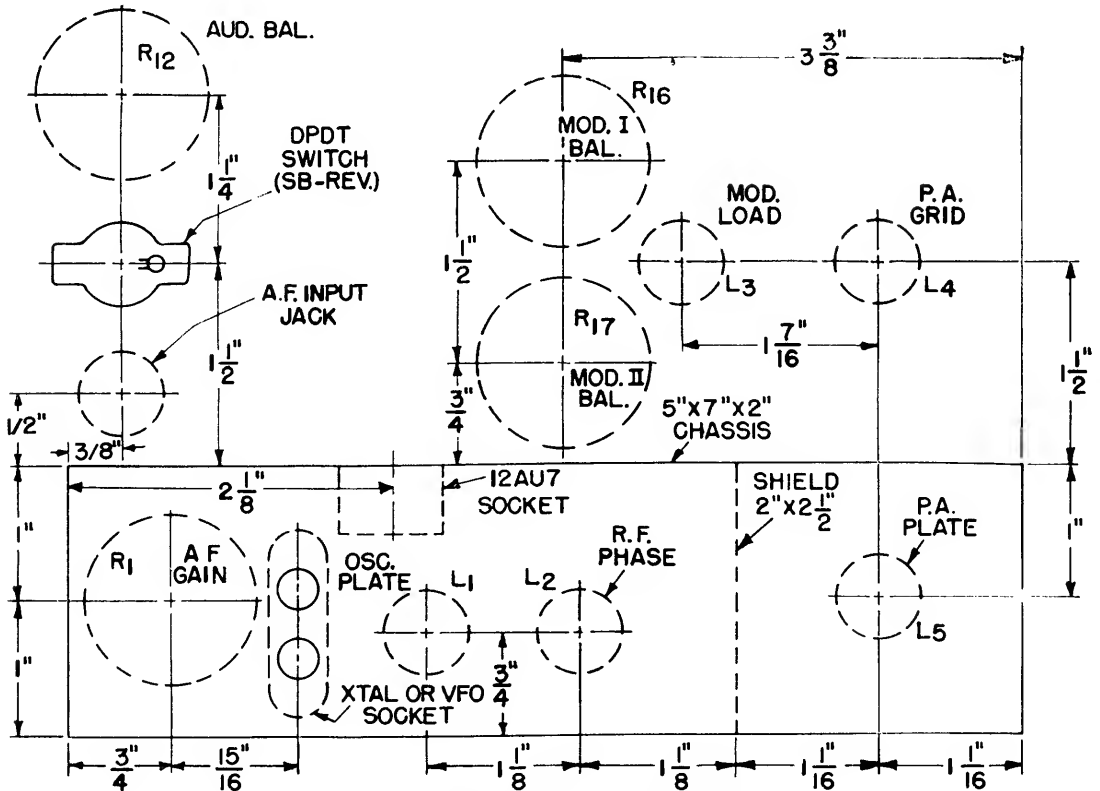

Fig. 10. SSB Jr. panel layout (front view)

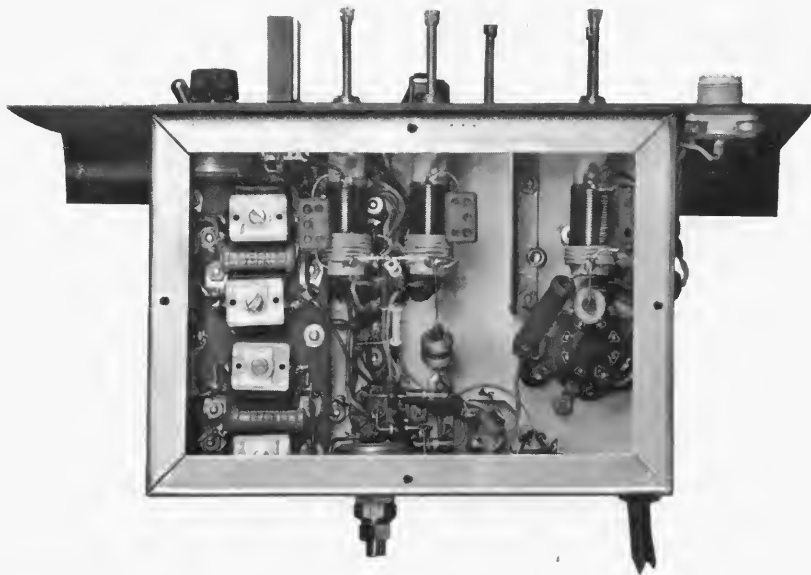

Fig. 11. Under-chassis view of the SSB Jr.

Transmitter Adjustment

Install the phase-shift network in the chassis, remove the 6AG7 output tube, plug in a crystal (3850 to 4000 KC) or supply a signal to the crystal socket from a VFO at not less than a 10 volt (RMS) level, set L_1 and L_2 for minimum inductance (slug out, counterclockwise) and apply power. The current drain should be about 35 to 40 MA at 300 volts under this condition with the oscillator operating. If the current drain is over 45 MA, turn off the B+ power, adjust L_1 , reapply power, etc., until the crystal oscillates. This may be checked by means of a receiver tuned to the crystal frequency. Continue to advance the slug in L_1 with the crystal operating until oscillation ceases. Then back the slug out a few turns to assure stable crystal operation. For VFO input simply adjust L_1 for minimum total current.

Apply an audio signal of 1225 CPS to the input jack of the exciter and connect the horizontal deflection of the oscilloscope to a cathode (pin 3) of the 12AT7, and the vertical deflection to the other cathode (pin 8) after making certain that the oscilloscope is phase-compensated at the frequency of 1225 CPS. Adjust R_5 to produce a circle on the screen. Adjust R_{12} to about mid-range. This test should be made at a reasonably low audio signal level (in general, the lower the better).

Now plug in the 6AG7, after checking to see that a bias of about $10^{1/2}$ volts is supplied. Connect the output link on L_3 to the vertical plates of the oscilloscope (no amplifier used). Deliberately unbalance one of the modulators by setting R_{16} appreciably off-center. Adjust L_5 for maximum vertical deflection at any convenient sweep speed. This deflection may be small at first since other circuits are not yet tuned. Adjust L_3 for further increase of deflection (maximize), and then finally tune L_4 for maximum output. As this tuning is done it may be necessary to reduce the modulator unbalance to keep from overloading the output stage. Check the tuning again on L_3 , L_5 , and L_4 , in that order. Next remove all audio input by turning R_1 to zero, and, by successive alternate adjustments of R_{16} and R_{17} , balance the modulators for zero output as seen on the oscilloscope. It will be noted that as the correct points are reached the mini-

mum point becomes successively sharper on each control.

Next apply some 1225 CPS audio tone to the exciter by advancing R_1 . Undoubtedly some RF envelope will be seen. Adjust L_2 (the RF phase control) in such a direction as to reduce the "modulation" appearing on the output. Remove the tone, check modulator balance (R_{16} and R_{17}), and repeat the adjustment of L_2 . The crystal (if used) may stop oscillation during this operation due to interaction between L_2 and L_1 tuning. If so, back out the slug on L_1 until stable crystal operation is obtained. With the 1225 CPS audio signal still applied continue to adjust L_2 for minimum "modulation" or ripple on the envelope, checking modulator balance periodically. When a minimum point is reached, adjust R_{12} to still further reduce this ripple, then adjust L_2 for more reduction, etc. until a substantially ripple-free display is seen.

With L_2 tuned it is now time to check the r-f voltages applied to the modulators. Temporarily remove the audio tone and connect the vertical deflection plate of the oscilloscope to the arm of R_{16} . Always keep the common connection of the oscilloscope grounded to chassis. Note the deflection and then check the voltage on the arm of R_{17} in a similar manner. If this is appreciably lower than the first voltage (on the arm of R_{16}) more coupling capacity (C_c) is necessary between L_1 and L_2 .

Usually very little capacity is required, and this can be provided conveniently by making a condenser of two pieces of insulated wire twisted together for half an inch or so. Adjust the amount of capacity by clipping off a little bit at a time to approximately equalize the RF signals appearing on the arms of R_{16} and R_{17} . (Note: check both voltages after each adjustment of capacity, since both voltages will change.) Connect the oscilloscope to read r-f output from L_3 as before, and then check modulator balance. Apply the 1225 CPS tone and make whatever slight adjustment is necessary in L_2 tuning to obtain the ripple-free display obtained before the coupling capacitor (if necessary) was installed. Remove the audio tone and check modulator balance (R_{16} and R_{17}). This completes the adjustment of SSB, Jr. A dummy load may now be connected, or the output used to drive a high power *linear* amplifier.

Operating Information

Note that when changing frequency, L_1 , L_2 , L_3 , L_4 , and L_5 should be readjusted, since these circuits constitute the tuning adjustments of the rig. The principal effect of mistuning L_2 , L_4 , and L_5 will be lower output or efficiency. *The principal effect of mistuning L_2 will be degraded sideband suppression. It is quite important, therefore, to adjust L_2 very carefully.* It may be noticed that when large audio signals are applied, the envelope develops some ripple. There are two possible causes for this action. The first is carrier unbalance (carrier shift), and the other is harmonic distortion in the audio circuits. (It is assumed that a pure sine wave of 1225 CPS is used as the input signal.) One may isolate these two effects by setting carrier balance at high-level audio operation (where these effects generally are most pronounced) to reduce the "ripple." With the carrier ripple (which is easily identified when the carrier balance controls R_{10} and R_{11} are moved) balanced out, adjust L_2 slightly (in conjunction with R_{12}) for minimum envelope ripple. The remaining ripple should be less than 5% of the display and is most probably caused by audio distortion, either in the audio source or in the audio system of the transmitter. In observing ripple, the oscilloscope should be synchronized from the 1225 CPS audio signal at a frequency of about 122.5 CPS to show ten cycles or so of carrier ripple. Unwanted sideband ripple will show twice as many peaks, and so will second harmonic audio distortion. Third harmonic audio distortion will show three times as many peaks, etc. Of course, all these distortions (and maladjustments) may occur simultaneously, so a little care and thought is advised. In the sample SSB Jrs. tested, third harmonic audio distortion is the principal component, and is

easily identified at high levels.

When feeding a load the total input current will rise to about 80 MA at full level with a single tone input. With speech input the current will rise syllabically from a resting value of about 60 MA to around 70 MA, depending on the waveform. Always use an oscilloscope to determine maximum operating levels. Overload will cause degradation of the sideband suppression, and so is to be avoided. Sideband cancellation adjustments performed at about half peak level are probably the most reliable ones. Carrier balance is best made with little or no audio input. Peak level is the audio signal level which causes flattening of the peaks due to amplifier overload. A higher input level can be used when working into a load, but the overload condition should be avoided while making adjustments and later, too, when operating the rig.

The sideband selector switch is used to control which sideband (upper or lower) is generated. Find out which switch position corresponds to upper sideband by tuning the exciter output signal on a receiver with its BFO supplying carrier. Conduct a talk test and tune the receiver for normal speech output. Then tune the receiver to a slightly lower frequency. If the voice pitch rises, the upper sideband is being generated. Identify switch positions accordingly.

It takes about 15 minutes from a "cold" start to make all the adjustments described here after a little experience is gained. Do not be frightened away from single-sideband because of a lengthy description of the adjustment procedure, since the adjustments are simple to do, and you will find that the description is actually very detailed and complete. Another reason for not being frightened away from single-sideband is that extremely modest equipment affords the most reliable phone communication yet developed.

NOTES ON THE DESIGN OF THE SSB, JR.

Because the SSB Jr. rig design is made possible by a new type of phase-shift network, and a new style modulator, it seemed desirable to have the designer, W2KUJ, explain these units in further detail for the benefit of the technically minded readers of *Ham News*.--Lighthouse Larry

The SSB Jr. is a superbly simple rig. Such things just don't happen by accident, however. Throughout the design many new ideas were employed to save space and reduce complication while not sacrificing performance in any way. Easy adjustment for optimum performance was a foremost point of design.

The phase-shift network is an example of simplification of this sort. Literally hundreds of laborious calculations were made along the way to the final solution. The result is a better performing network that has only eight parts and is really very easy to adjust properly. Two methods of adjustment are possible. The first (and preferred one) has already been explained in detail. The other one is obvious. Merely put in accurately measured values and call the job done. The problem here is to obtain the accuracy needed (absolute accuracy) since standards of resistance and capacity are obviously of a different nature. By making adjustments which involve both resistance and capacitance values simultaneously in conjunction with a single reference frequency, almost all sources of error are eliminated. And that is why the preferred method is preferred. All this accuracy is wasted, however, if the components used are not stable enough to hold their values after selection. This is why precision resistors are specified, and why only

a small range of adjustment is provided by the trimmer capacitors, since the trimmers are the most likely circuit elements to change. In this way good stability is obtained.

A word about operating conditions necessary for the phase-shift networks. The outputs must feed very high impedance circuits. The effective source impedance should be low, and the voltage supplied to A,E must be minus 0.2857 times the voltage supplied to D. Incidentally, the voltage output of each section is equal to the voltage at A,E from zero frequency to a matter of megacycles. The design center frequency for the two networks (yes, there are actually two) is 800 CPS. The differential phase-shift versus frequency curve is symmetrical about this point and holds to within 1.3 degrees from 225 CPS to 2750 CPS, as indicated in Fig. 12. A slight error in setting the reference frequency (3960 CPS) will result only in shifting this band up or down by the same percentage. The operating band is adequate—even desirable for voice communication. One need not fear reports of poor quality when using this rig.

Another simplification which deserves comment is the balanced modulator used in SSB Jr. Let's take a few moments to consider what takes place in the circuit. Fig. 13 shows just one modulator consisting of two germanium diodes, G_1 and G_2 with associated circuits. First, suppose a high frequency signal of a few volts is applied at point R. On the positive crest of signal, current passes through G_2 into the center tapped resonant circuit and tends to pull point S in the same direction. Point T naturally tends to go negative because of the phase inverting properties of the resonant circuit, but, of course, no current flows through G_1 . One half cycle later current passes through G_1 from

the source, tending to pull point T in the negative direction. But at this time point T would be at a positive potential because of the "inertia" of the resonant circuit. The net result of the battle between G_1 and G_2 to cause current to flow in the resonant circuit is a draw. No net voltage appears across this circuit at the source frequency and energy is dissipated in the balancing resistor and in G_1 and G_2 . Thus far, we have currents in the resonant circuit, but none at its operating frequency. This seems like a long way to go to get nothing, but wait.

Now, let us imagine a bias applied at U. If the voltage at U is positive, G_2 will pass more current into the resonant circuit, and G_1 will pass less current. This, in effect, unbalances the circuit and a radio frequency voltage will appear across the resonant circuit, with point S in phase with the voltage at R. If the bias voltage at U is negative, G_1 passes more current than G_2 , and the circuit is unbalanced in the other direction. Under this condition the voltage at T will be in phase with that at R. Obviously, if the voltage at U is an audio frequency voltage, the circuit is unbalanced in one direction or the other (at an audio frequency rate) and the resulting radio frequency voltage across the resonant circuit is actually two sets of sidebands with no carrier. When another pair of diodes (such as G_3 and G_4 of Fig. 2) is connected to feed currents into the resonant circuit from related audio frequency and radio frequency sources respectively 90° out of phase with the first, sideband currents caused by these signals flow through the resonant circuit in such a manner as to reinforce one set

of sidebands and to cancel the other set. The result is a single-sideband suppressed carrier signal. In the case of SSB Jr., it is a really high grade one.

The function of the balancing resistors (R_1 and R_2 of Fig. 2) is to equalize minor differences in the characteristics of the diodes and to balance out stray couplings. Thus, any one balanced modulator is not necessarily perfectly balanced, but the action of two such modulators fed with polyphase signals allows a complete composite balance.

What about operating SSB Jr. in other amateur bands or at other frequencies, in general? As described, the radio frequency circuit design is for the 75 meter band, 3850 to 4000 KC. There is no reason, however, to think that equally successful performance would not be obtained on 20 or 10, or even on what is left of 160. It's simply a matter of coil design.

The unit pictured in this issue of *Ham News* was the second one ever built. Ten minutes after the last solder joint had cooled down, the rig was perfectly adjusted and was delivering 5 watts peak power to a 75 ohm dummy load—and I followed the adjustment procedures described in the article. Maybe it will take some people a little longer to read the instructions than it did for me (after all, I wrote them), but 1, 2, 3 procedure really does the job. I didn't peek ahead in the instructions, either.

If you get one-tenth the fun out of building and operating SSB Jr. as I did in designing, building and using it, you are in for the most enjoyment you have ever had in ham radio. —W2KUJ

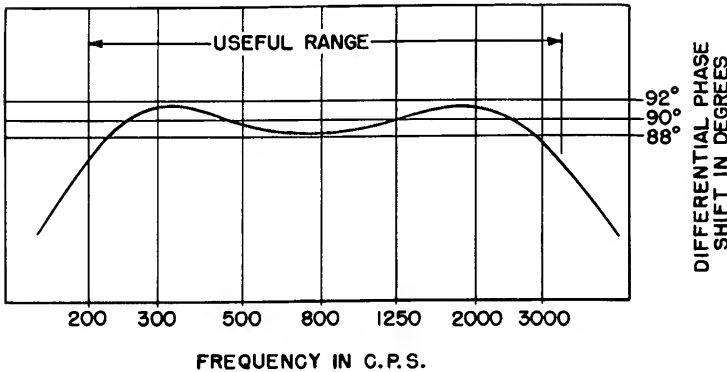
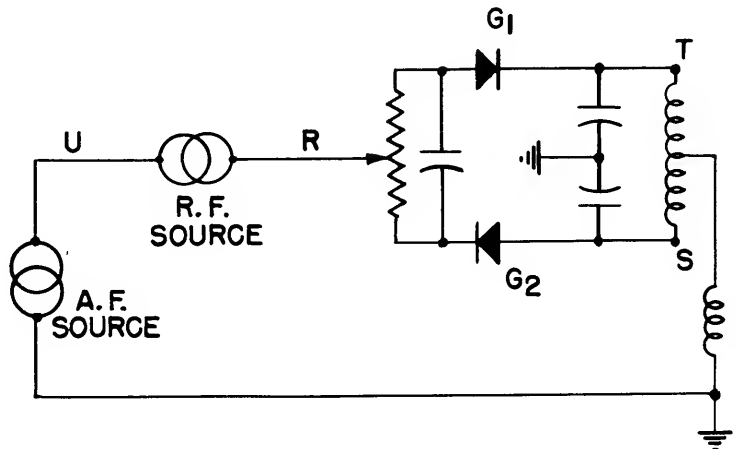

Fig. 12. Audio phase-shift network performance

Fig. 13. SSB Jr. modulator circuit



USING THE SSB, JR. ON OTHER BANDS

The G-E HAM NEWS SSB, Jr., may be operated on other than the original design frequency by one of two methods. First, a separate set of circuit constants may be plugged or switched into the circuit for each amateur band to be covered. Second, the SSB, Jr., may be placed on a fixed frequency outside the amateur bands, then heterodyned to the desired output frequency in a mixer stage that also is driven by a stable oscillator having the appropriate frequency range. A low-level mixer is preferred and may be driven directly from the diode balance modulator, instead of through the 6AG7 stage.

Operation on 50 megacycles is possible by either running the SSB, Jr., directly on that band, or by using single or double conversion. When heterodyning, the precautions outlined in the November-December, 1956 (Vol. 11, No. 6) issue of G-E HAM NEWS should be followed.

The SSB, Jr. can be placed directly on 50 megacycles by scaling down capacitors C_5 , C_{11} , C_{17} , C_{18} , C_{20} and C_{21} by the ratio of frequencies involved, or 4/50 of the original values. The corresponding coils L_1 to L_5 will then have to be reduced in inductance until the circuits tune to resonance at 50 megacycles. The correct value for C_5 , C_{11} and C_{17} is 10 mmf; C_{13} , 20 mmf; and C_{20} and C_{21} , 150 mmf. These values allow for the tube and stray circuit capacities that assume a large proportion of the total capacity at this frequency. Inductance L_1 to L_5 should be adjusted experimentally until all circuits tune to 50 megacycles.

A simpler method is to leave the SSB, Jr. on its fixed 4-megacycle frequency and feed the output into a frequency mixer, with

46 or 54 megacycles as the beating frequency. It will be necessary to use a double-tuned output circuit, such as used in an IF transformer, and tune traps to the 46 or 54-megacycle frequencies to prevent these from also showing up in the mixer output.

Another method is to place the SSB, Jr. on 9 megacycles, also by scaling down the capacitors and coils mentioned above, and use a 41 or 59 megacycle beating frequency in the mixer. This system will have lower spurious output than the previous one.

Circuit constants for 9 megacycles are given below:

These specifications apply to coils wound on the same forms used in the original model, Millen No. 69046, with iron tuning slugs. They are 1/2-inch diameter and have a winding length of 1-1/8 inches. Coil L_2 has the most critical adjustment, as it is the 180 degree RF phase shift network and will have to be retuned each time a shift of more than 5 kilocycles is made in the 9-megacycle frequency.

C_5 - 110 mmf.	L_1 - 19 turns No. 20 enameled wire spacewound 1 inch long. (2.8 uh)
C_{11} - 110 mmf.	L_2 - same as L_1
C_{20} - 880 mmf. } C_{21} - 880 mmf. }	L_3 - 9 turns No. 20 enameled wire spacewound 1-1/8 inches long. (0.6 uh)
C_{17} - 110 mmf.	L_4 - 17 turns No. 20 enameled wire spacewound 1 inch long. (2.4 uh)
C_{18} - 150 mmf.	L_5 - 14 turns No. 20 enameled wire spacewound 1 inch long. (1.75 uh)

From May-June, 1959

200-WATT DOUBLE SIDEBANDER

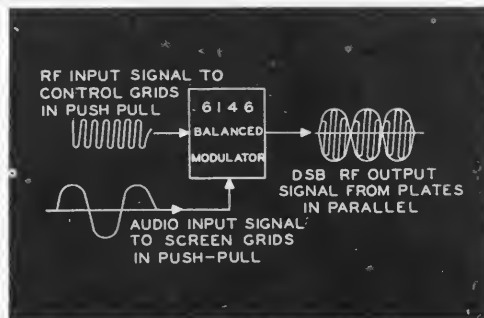

Our **DOUBLE SIDEBAND JUNIOR** article a year ago sparked much interest in a more powerful double sideband transmitter with bandswitching. Now several radio amateurs at General Electric have combined their ideas in this transmitter with 200-watt peak power input capability from a pair of 6146 beam pentodes in the output stage. The complete circuit, and constructional details on the plug-in r.f. unit, is in this issue. Part II, in the July-August, 1959 issue, describes the main chassis containing audio system, power supplies and control circuits.

200-WATT DOUBLE SIDEBANDER

Part I

THIS DOUBLE SIDEBAND transmitter is packed with ingenious circuits and construction features. Try them!

THE DOUBLE SIDEBANDER was designed specifically for this mode of transmission; and, in fact, was a prototype for military double sideband and synchronous communications equipment. The frequency coverage is continuous from 2 to 30 megacycles in four bands. It has a peak power output, with sine-wave modulation, of 150 and 120 watts at 2 and 30 megacycles, respectively.

THE R.F. SECTION of the transmitter—a separately shielded and filtered unit—employs an oscillator-driver-final circuit arrangement as shown in the schematic diagram, FIG. 1. All transmitter stages are provided with protective bias to prevent damage to the tubes in the absence of excitation. In the oscillator and driver stages cathode self-bias give the necessary protection. The final stage protective circuit removes its high voltage if the r.f. drive fails.

Switch $S1_A$ in the grid circuit of the 6AH6 oscillator stage provides selection of one of the four crystals or the V.F.O. input as the frequency source. With $S1_A$ in the V.F.O. position the 6AH6 is employed as a Class A amplifier. An input from a V.F.O. of 0.5 to 1 volt r.m.s. will excite the driver stage.

All frequency multiplying is accomplished in the oscillator and the 6CL6 driver always operates as a straight amplifier. Since the pi network in the 6146 balanced modulator plate acts as a low-pass filter, sub-harmonics of the carrier frequency may appear in the transmitter output if the driver stage is operated as a frequency multiplier.

Careful circuit layout and complete r.f. bypassing stabilize the driver stage. The 15,000-ohm, 4-watt potentiometer ("PA GRID DRIVE") adjusts the 6CL6 screen voltage and, in turn, its r.f. power output.

The 6146 balanced modulator stage has the usual push-pull control grids, push-pull screen grids and paralleled plates described in several previous double sideband transmitter articles.¹ The pi-network plate circuit is designed for a 50-ohm output, but will load into impedances up to 300 ohms.

THE MODULATOR SECTION is designed for use with a low-level, high-impedance microphone (crystal, ceramic or dynamic). Low impedance microphones will require a matching transformer. The preamplifier stage (V_7)

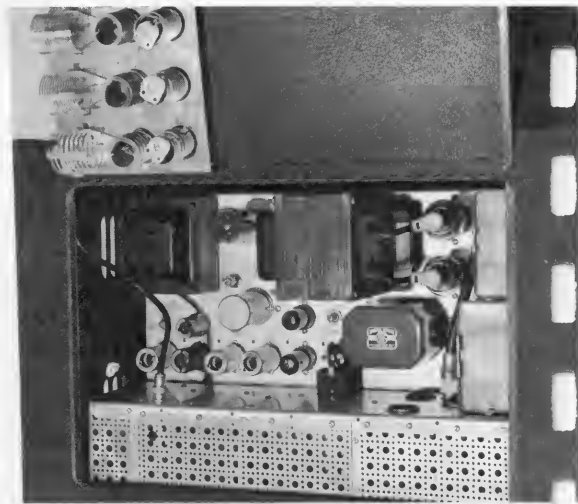

THE TRANSMITTER CABINET with the top lid open, showing the shielded r.f. compartment in the front, audio section in the middle and power supply at the rear. Note the method of storing spare plug-in coils on an aluminum plate, on which 4 and 5-pin sockets have been mounted. Coils are changed in the exciter simply by removing four self-tapping screws which hold the shield at left-center in place.

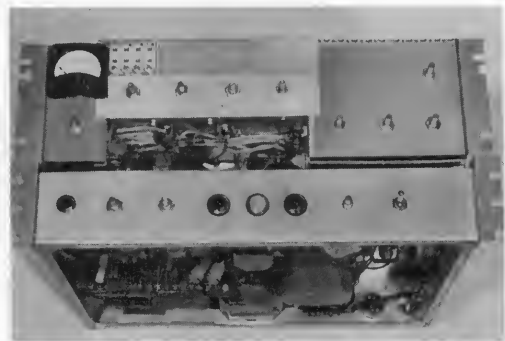

FRONT VIEW OF THE TRANSMITTER with cabinet and panel removed. The separate chassis containing the r.f. and metering section plugs into the main chassis, containing the remaining circuits.

has a push-to-talk feature that cuts off the second section until closing the microphone switch greatly reduces the cathode bias. A twin diode tube (V_9) serves as an audio peak clipper. The next tube (V_8) is a matching device for the maximally-flat (Butterworth) L/C 3,000-cycle low-pass filter.

A 400-cycle phase-shift R/C sine wave oscillator (V_{10B}) and a split-load phase audio phase inverter (V_{10A}) precede the push-pull driver (V_{11}). The modulator tube (V_{12}) provides about 300 volts peak on each screen grid of the 6146 balanced modulator stage. About 8 decibels of inverse feedback in the driver and modulator stages improves balance and linearity in the 6146 stage.

(continued on page 6)

¹See G-E HAM NEWS, March - April, 1959, for a bibliography of articles on double sideband techniques.

PARTS LIST—200 WATT DOUBLE SIDEBANDER

- C₁ 150-mmf mica, 500-volt rating.
 C₂ 10-mmf mica, 500 volt (change value if crystal is erratic).
 C₃ 500-volt, 10 percent mica mounted in L₁; (See coil table for values).
 C₄ 3—30-mmf midget ceramic trimmers mounted on L₁.
 C₅ 6—142-mmf variable, 0.020-inch air gap (Hammarlund HFA-140-A).
 C₆ 6—142-mmf per section, 2-section variable (Hammarlund HFD-140).
 C₇ 10—200-mmf variable, 0.024-inch air gap (Hammarlund MC-200-M).
 C₈ 0.001-mfd, 2500-volt mica (0.001-mfd, 5000-volt ceramic also suitable).
 C₉ 13.5—325-mmf air variable, 0.24-inch air gap (Hammarlund MC-325-M).
 C₁₀ 82-mmf, 500-volt mica (Change value to suit audio response).
 C₁₁ 0.0018-mfd, 500-volt mica (Value determines cutoff frequency of filter).
 C₁₂ 620-mmf, 500-volt mica (Value determines cutoff frequency of filter).
 C₁₃, C₁₄ 8-mfd, 1500-volt oil-filled paper capacitors.
 F₁, F₂ 5-ampere type AGC fuses and holders.
 L₁ 6.3-volt pilot lamp and jeweled bracket.
 L₂ 115-volt pilot lamp and jeweled bracket.
 J₁, J₂ chassis type coaxial cable connectors (SO-239).
 J₃ chassis type 2-pin recessed male power connector.
 J₄ chassis type 8-pin male power connector (Jones P-308-AB).
 J₅ chassis type 2-pin female microphone connector (Amphenol 80-PC2F).
 K₁ 2-pole, 2 position sensitive relay, 2-ampere contacts, 10,000-ohm coil with 3- to 5-ma energizing current (Potter & Brumfield LM-11 or KCP-11).
 K₂ 2-pole, 2-position power relay, 5-ampere contacts, 115-volt, 60-cycle coil.
 L₇, L₈ 10 henry, 175-milliampere smoothing filter choke.
 L₉ 5—25 henry, 175-milliampere swinging filter choke.
 L₁₀ 3 henry, iron core inductance (toroidal type core preferable).
 M₁ 0—1-milliampere panel meter, 2½ inches square (G.E. DW-71 or DW-91).
 P₁ 8-pin cable type female power connector (Jones S-308-CCT).
 RFC₁, RFC₂, RFC₃, RFC₄ 2.5-mh, 100-ma r.f. choke (National R-100).
 RFC₅ 2.5-mh, 300-ma r.f. choke (National R-300 or equivalent).
 S₁ 3-pole, 5-position, 2-section ceramic rotary tap switch (Centralab 2515).
 S₂ 1-pole, 4-position, 1-section 90-degree ceramic-insulated rotary tap switch, (Centralab No. 2542 or equivalent).
 S₃ 1-pole, 10-position, 1-section, progressive shorting ceramic-insulated rotary tap switch (Centralab P1-S wafer and P-121 index assembly).
 S₄ 2-pole, 11-position, 2-section rotary tap switch (Centralab 1413).
 S₅ 3-pole, 3-position, 1-section rotary tap switch (Centralab 1407).
 S₆ 2-pole, 2-position, 1-section rotary tap switch (Centralab 3122J).
 S₇ 2-pole, 2-position heavy duty toggle switch.
 T₁ audio driver transformer; turns ratio, primary to ½ secondary: 4 to 5. (Use primary of transformer as secondary in this application.)
 T₂ filament transformer: secondary, 2.5 volts at 5 amperes; 115-volt primary.
 T₃ plate transformer: 2400 volts, center tapped at 150 ma; 115-volt primary.
 T₄ power transformer: secondaries, 700 volts center tapped at 150 ma; 5 volts at 3 amperes; 6.3 volts at 6 amperes; 115-volt primary.

TABLE I—COIL WINDING DATA

NOTE: All coils are wound with tinned copper wire in the sizes specified below.
 L₁ wound on 1-inch diameter, 4-pin plug-in forms. Winding length is 1 inch. Copocitors C₃ and C₄ are mounted inside each coil form.
 L₂ wound on 1-inch diameter, 5-pin plug-in forms. Winding length is 1 inch. Link coil L₁ wound at grounded end of L₂ on each form.
 L₄, L₅ B & W "Baby" inductors, center tapped with center link coils, and

L₃ 5-pin base.
 L₃ 10.5 uh total, 28 turns 1½ inches in diameter, 4 inches long. Wound with 22 turns of No. 12 (7 turns per inch) and 6 turns of No. 10 (5 turns per inch) tinned copper wire, tapped at 6, 9 and 15 turns from the end with No. 10 wire.

Band, MC	L ₁ and L ₂			L ₂ Only		L ₁	L ₄ & L ₅	L ₃ Output Coil	
	Ind., uh.	Turns	Wire Size	Turns, L ₃	Wire Size	C ₃ mmf.	B & W Number	Turns in Use	Ind., uh.
3.5	17.4	31	24	3	16	82	30MCL-2925	28	10.5
7	4.6	16	18	3	16	68	40MCL-2924	15	5
14	1.4	8	16	2	14	56	20MCL-2923	9	2.4
21 ¹	0.75	6	16	—	—	39	—	—	—
28	0.45	4	14	2	14	27	10MCL-2921	6	1.3

¹28-megacycle coils tune to the 21-megacycle band. A separate 21-megacycle oscillator coil (L₁) is required only when crystals oscillating at this frequency, or a VFO having output at 21 megacycles, are used with transmitter.

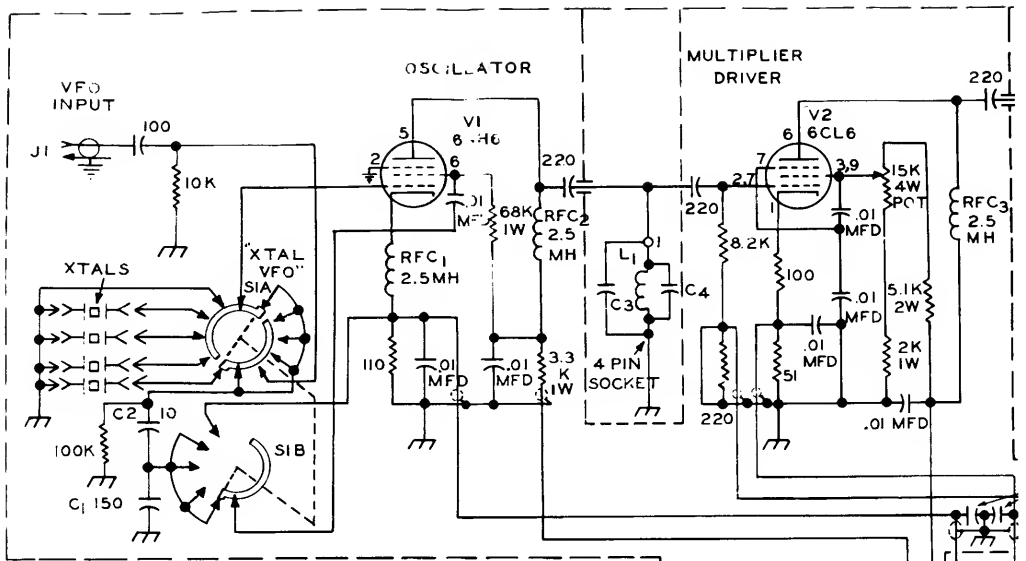

POSITION ON 54

	CIRCUIT MEASURED	FULL SCALE READING	NORMAL READING
1	OSCILLATOR CATHODE CURRENT IK1	20 MA	10 MA
2	DRIVER GRID CURRENT IG2	10 MA	2 MA
3	DRIVER CATHODE CURRENT IK2	40 MA	20 MA
4	FINAL GRID CURRENT, V3	IG3	10 MA
5	FINAL GRID CURRENT, V4	IG4	10 MA
6	FINAL CATHODE CURRENT, V3	IK3	100 MA
7	FINAL CATHODE CURRENT, V4	IK4	100 MA
8	FINAL PLATE CURRENT	IB3,4	200 MA
9	R.F. OUTPUT VOLTAGE	9	100 VOLTS RMS
10	MEDIUM SUPPLY VOLTAGE SUPPLY		400 VOLT ; DC
11	HIGH VOLTAGE SUPPLY		2,000 VOLT ; DC

* MEASURED WITH FULL SINE WAVE MODULATION

R.F. UNIT HEATER CIRCUIT

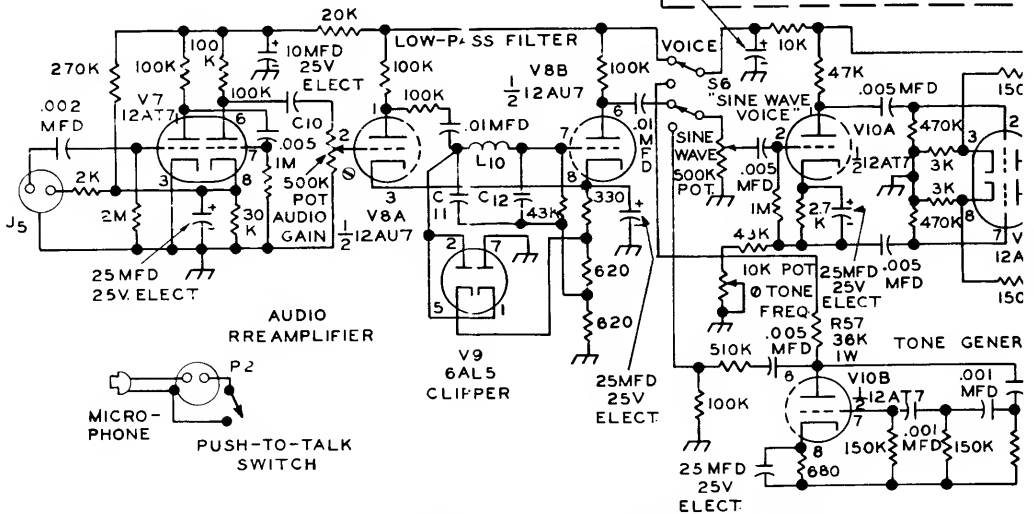
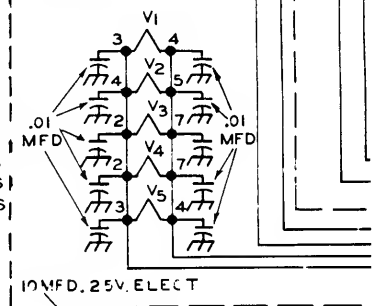
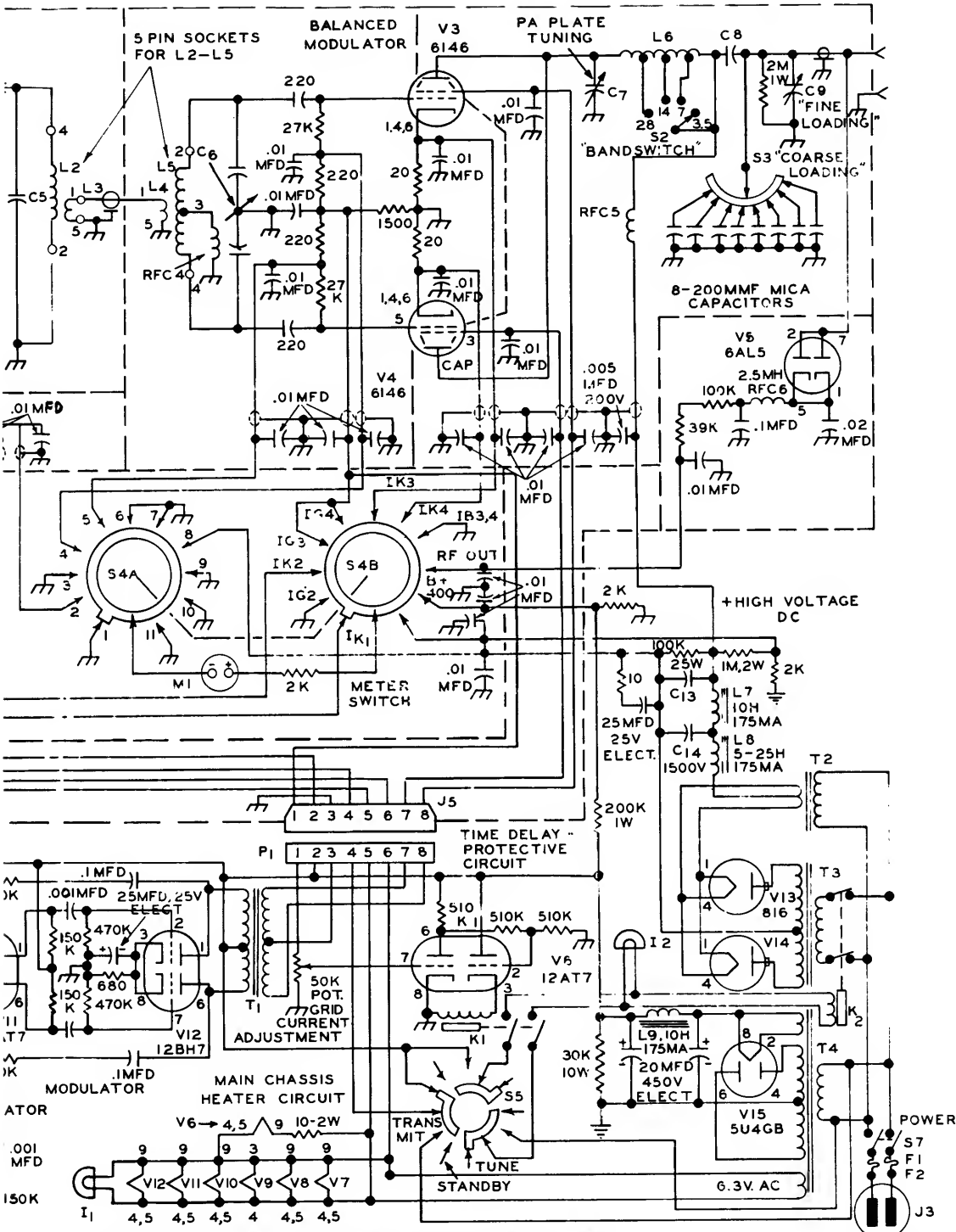

FIG. 1. COMPLETE SCHEMATIC DIAGRAM of the 200-watt double sideband transmitter. The r.f. circuit runs across the top of the diagram, with the meter switching circuit below it. The audio system is at the lower left and the power supplies at the lower right. The 12AT7 time delay-protective tube is just to the left of the power supplies.

All capacitances are in mmf, except where otherwise specified. All r.f.



coupling capacitors and the 200-mmf mica capacitors on S_3 are micas. All 0.01-mfd bypass capacitors are disc ceramic, 1000 volts working, unless otherwise noted. Resistances are in ohms (K=1000; MEG=1,000,000), $\frac{1}{2}$ -watt power rating, unless a higher rating is specified.

Data for winding all the r.f. coils (L_1 to L_6) appears in the COIL TABLE below. The tube types for V_1 to V_{15} appear on the diagram. Shielded wires are indicated by dotted loops encircling the wire. Shielding around r.f. circuitry is shown in dashed lines.

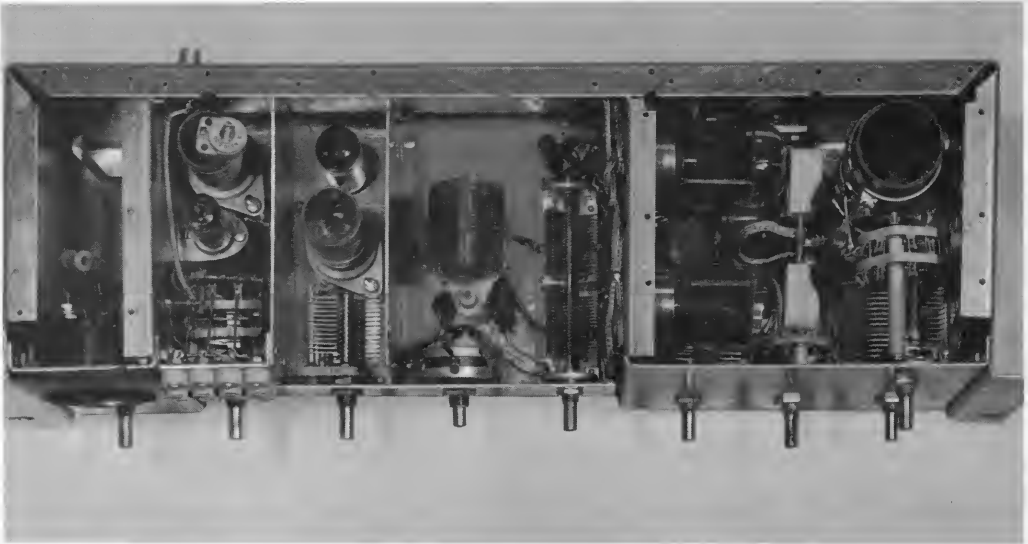

TOP VIEW of the r.f. unit with shield covers removed. Note shielding partitions between stages and horizontal mounting of 6146 tubes on shield to isolate

grid and plate circuits in the balanced modulator output stage. Main chassis is a 5¼-inch high panel chassis designed for relay rack mounting (Bud CB-1372, or equivalent).

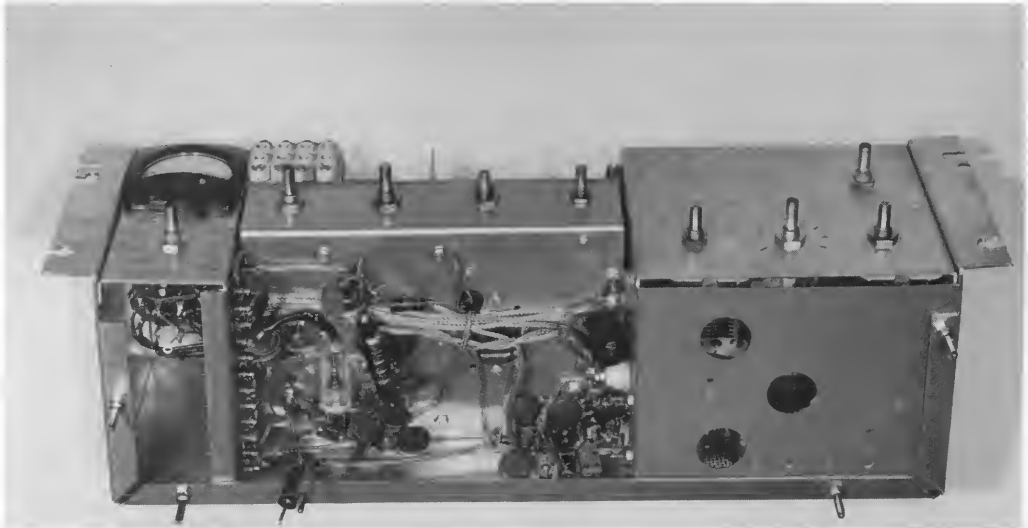

BOTTOM VIEW of the r.f. unit. The four banana plugs on the lower rim of the chassis plug into matching jacks on the main chassis. High voltage for the 6146's enters the r.f. unit via a Millen 37001 high voltage connector and the white feed-through insulator on the 6146 compartment shield. The phone-tip jack at the

lower left is for plate voltage to the oscillator. Two phono plugs, connected to the row of feedthrough terminals on the meter compartment, are for the 400 and 2000-volt metering circuits. Note the liberal use of 0.01-mfd disc ceramics bypass capacitors and shielded wire for the power and metering circuits.

DOUBLE SIDEBANDER

Both power supplies are of conventional design. The high voltage supply is rated at 1000 volts DC at 145 milliamperes; and the low voltage supply delivers 360 volts DC at 110 milliamperes, both continuous duty.

ADDITIONAL CIRCUITRY on the schematic diagram includes the power supply time delay and 6146 protective circuit. A 10-ohm resistor in series with the heater to this tube (V_6) increases its heating time. This prevents application of high voltage to the 816 mercury vapor rectifiers (V_{13} and V_{14}) for 30 seconds and allows their filaments to

reach operating temperature. When no r.f. drive is applied to the 6146's the left-hand triode of V_6 has no negative bias and draws sufficient plate current through its 500,000-ohm plate resistor to nearly cut off plate current in the right-hand triode. Application of sufficient r.f. drive to the 6146's reduces plate current flow in the left-hand section of V_6 . This swings the grid of the right-hand section more positive, resulting in increased plate current flow which energizes relay K_1 . This in turn energizes K_2 , if S_5 is in the "TRANSMIT" position, and applies primary voltage to T_3 .

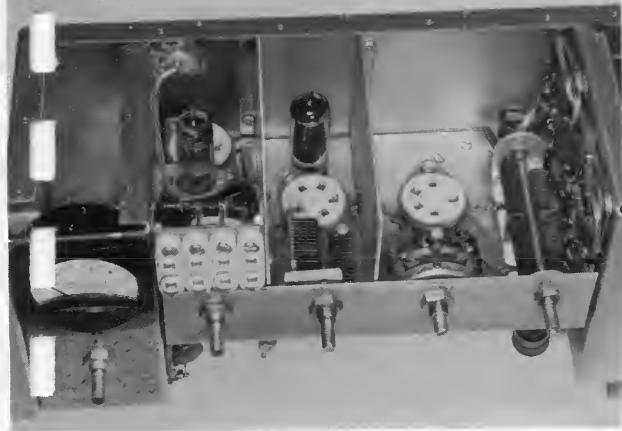

DETAIL VIEW of the wiring around the 6146 balanced modulator tube sockets. The standard technique of bypassing the ends of shielded wire has been used. The 6146 plate caps were joined with No. 12 tinned wire, then connected with thin copper strips to the circuit components shown in the schematic diagram, FIG. 1.

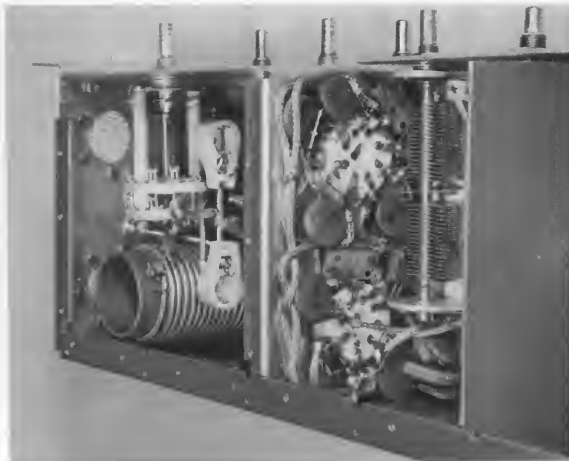

EXCITER COMPARTMENTS in the r.f. unit. Plug-in coils have been removed to show the coil sockets mounted on metal pillars $\frac{3}{4}$ of an inch high. All partitions and shelves were fabricated from 1/16-inch thick soft sheet aluminum. The crystal sockets were mounted on a bracket drilled to match the socket holes.

METERING OF ELEVEN CIRCUITS in the transmitter is accomplished with a single 0-1-milliamperemeter (M_1) and the meter switch (S_4). Switch positions—and the full-scale current or voltage reading in each position—are listed on the schematic diagram. The meter measures current by reading the voltage drop (2 volts for full-scale reading) across resistances in series with the various grid and cathode circuits.

Tube V_5 and its circuitry form a peak detector for measuring the r.f. output voltage of the transmitter. Since the meter reads 0.707 of the peak voltage, the average r.f. power output with sine-wave modulation can be calculated, if the transmitter is operated into a non-reactive load of known impedance.

MECHANICAL LAYOUT of the r.f. unit can be determined from the pictures and explanations accompanying them. Locations of the major components and approximate dimensions have been marked on each view. The usual modern r.f. construction practices have been followed: shielding, both over-all and between stages; shielded wire for all power and metering circuit connections; liberal use of bypass capacitors, etc.

Locations of the holes for the four banana plugs, shown in the bottom view, should be marked on the main chassis to insure proper alignment. Partitions and subchassis can be fastened in place with self-tapping screws; this is much easier than attempting assembly of nuts on machine screws in tight corners! The oscillator tube sits on a small angle bracket fastened to the partition between that stage and the metering compartment.

The oscillator plug-in coils (L_1) are assembled by first soldering two lengths of No. 14 tinned wire into pins 1 and 4 before winding the coil. Next the coil leads and C_3 are soldered to the wires. Finally, C_4 is soldered to the wires at the open end of the form.

TUNE-UP AND OPERATION will be described in this issue—since frequent reference is made to the schematic diagram—even though constructional details for the main chassis will be covered in the next issue. (In other words, we're tuning up the rig before you've finished building it—Ed.) The procedure is similar to any transmitter having class C amplifiers, with one exception: It is necessary to modulate the 6146 stage to obtain r.f. output.

After the usual check to see that all circuits have been wired correctly, plug in the power cord, the set of coils for the desired amateur band and turn the pi-network bandswitch (S_2) to the same position. Insert a crystal of proper frequency, or connect a stable VFO to J_1 and turn S_1 to the proper position. Connect a microphone to J_5 and a 50-ohm dummy antenna lead to J_2 .

Turn S_7 to the "ON" position and S_5 to the "TUNE" position. With S_4 in position 2, tune C_4 (on the oscillator coil form) with a screwdriver until about 2 to 3 milliamperes of grid current is indicated in the driver stage. Detune this capacitor slightly if the grid current exceeds 4 milliamperes.

Next, turn S_4 to position 3 and tune C_5 for a dip in driver cathode current. Turn S_4 to positions 4 and 5, and adjust C_6 for maximum grid current in the 6146 balanced modulator. Adjust the "PA GRID DRIVE" control for a reading of 3 milliamperes in each 6146. Now, turn the "GRID CURRENT ADJUSTMENT" potentiometer until relays K_1 and K_2 energize, as indicated by I_2 lighting. Turn the "PA GRID DRIVE" control until the 6146 grid current decreases to 2 milliamperes and again adjust the "GRID CURRENT ADJUSTMENT" until K_1 and K_2 open. The 6146 protective circuit is now adjusted.

To tune up the 6146 balanced modulator, set S_4 on position 6, S_5 on "TRANSMIT"

200-Watt Double Sidebander—Part II

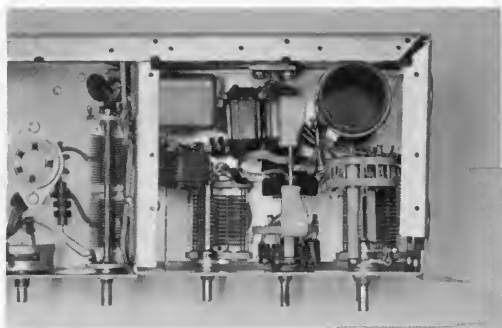

TOP VIEW of the 6146 compartment showing the positions of smaller components near the switches, capacitors and coils. The bandswitch, S_2 , was modified by adding longer side rods and spacers to shorten the connections to L_6 . This compartment was assembled before being fastened to the main r.f. chassis.

and S_8 on "SINE WAVE." Advance the "MOD. LEVEL" potentiometer (on main chassis) until the 6146 cathode current meter reading increases to 30 milliamperes. Tune C_7 for a dip in plate current. Turn S_4 to position 9 and adjust the "COARSE LOADING" (S_8) and "FINE LOADING" (C_9) controls for maximum output voltage on the meter. Readjust C_7 as necessary for maximum output.

Further advance the "MOD. LEVEL" control slowly to the setting at which little further increase in power output is indicated on the meter. Note this meter reading at which the balanced modulator begins to "flatten out." Next, turn S_6 to the "VOICE" position and adjust the "MOD. LEVEL" control, while talking or whistling into the microphone, until the peak output voltage reading on the meter reaches the maximum level noted with sine wave modulation.

Adjustment of the "AUDIO GAIN" and "CLIPPING LEVEL" controls is best made while listening to the transmitter signal, in addition to checking it for flattening of peaks on an oscilloscope. Too much clipping will introduce serious distortion. The "AUDIO GAIN" control setting will depend upon the sensitivity of the microphone and amount of room background noise in the shack.

CONSTRUCTIONAL DETAILS of the main chassis, and more operational data, are contained in the conclusion of this article on the latest in communication media.

The audio amplifier-modulator, control circuitry and power supplies for the 200-watt double sideband transmitter were constructed on a single 13 x 17 x 3-inch deep chassis (*Bud* AC-4, or equivalent). If the constructor desires, the power supplies could be built on a separate chassis—say 6 x 17 x 3 inches in size and attached in back of a 7 x 17 x 3-inch chassis for the audio section, and base for the r.f. unit.

Or, some constructors may prefer to utilize separate power supplies already available. If so the standard 7 x 17 x 3 or 8 x 17 x 3-inch chassis sizes will suffice. Tubes V_6 and V_9 can then be moved over in line with the audio tubes, and the whole line of tubes extended into the area occupied by L_7 .

Placement of major components on the main chassis is shown in the top and bottom views. No dimensions have been given, since the exact locations will depend on the sizes of the parts actually to be used in duplicating the transmitter. The same general configuration should be followed, since it has been found trouble-free.

Both control relays (K_1 and K_2) were located at the right side under the chassis, near the main power switch (S_1), fuses (F_1 and F_2), and the AC power input connector (J_3), but some distance from the time delay—grid current interlock tube (V_6).

The panel controls and indicator lamps line up vertically with the control shafts on the r.f. unit—spaced 2 inches—as shown in the front view on page 3 of the May-June, 1959 issue.

Grid and plate leads in the first few stages in the audio amplifier (V_7 , V_8 , V_9 and V_{10}) should be kept as short as possible to minimize hum pickup and the possibility of feed-back troubles. Medium voltage power and control circuits were wired with regular hookup wire; high voltage leads should be wire tested for several thousand volts. Pairs of wires carrying an alternating current should be twisted wherever possible.

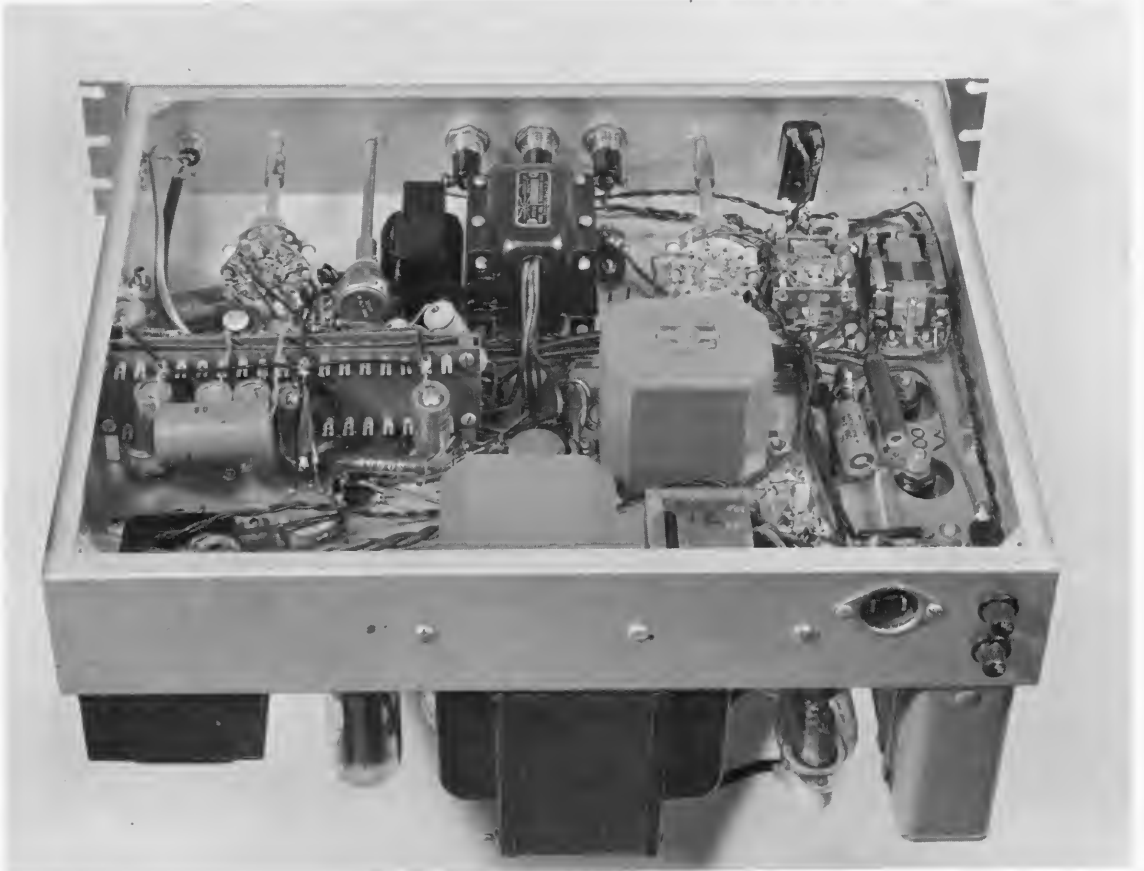

WELL-PACKED main chassis of the double sideband transmitter. Most small parts in the audio section were mounted on the two terminal boards shown back-to-back at the left side of the chassis in this view. The power input connector (J_3) and the fuse holders (F_1 and F_2) are on the rear apron of the chassis.

TOP VIEW of the main chassis with locations of the major parts indicated. The black jack near the front of the chassis is for high voltage to the r.f. unit. Three other jacks in front of the audio tubes are for metering circuit connections in positions 9 (r.f. output voltage), 10 (400-volt range) and 11 (2000-volt range) of the meter selector switch.

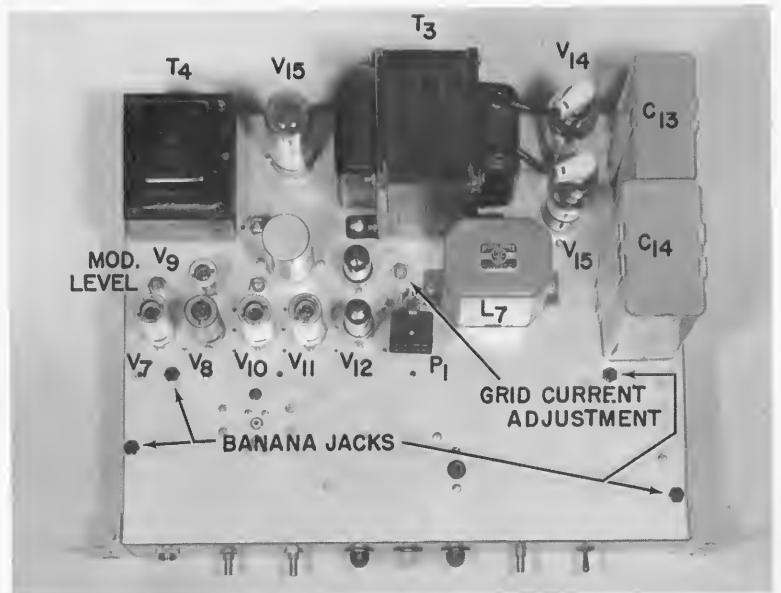

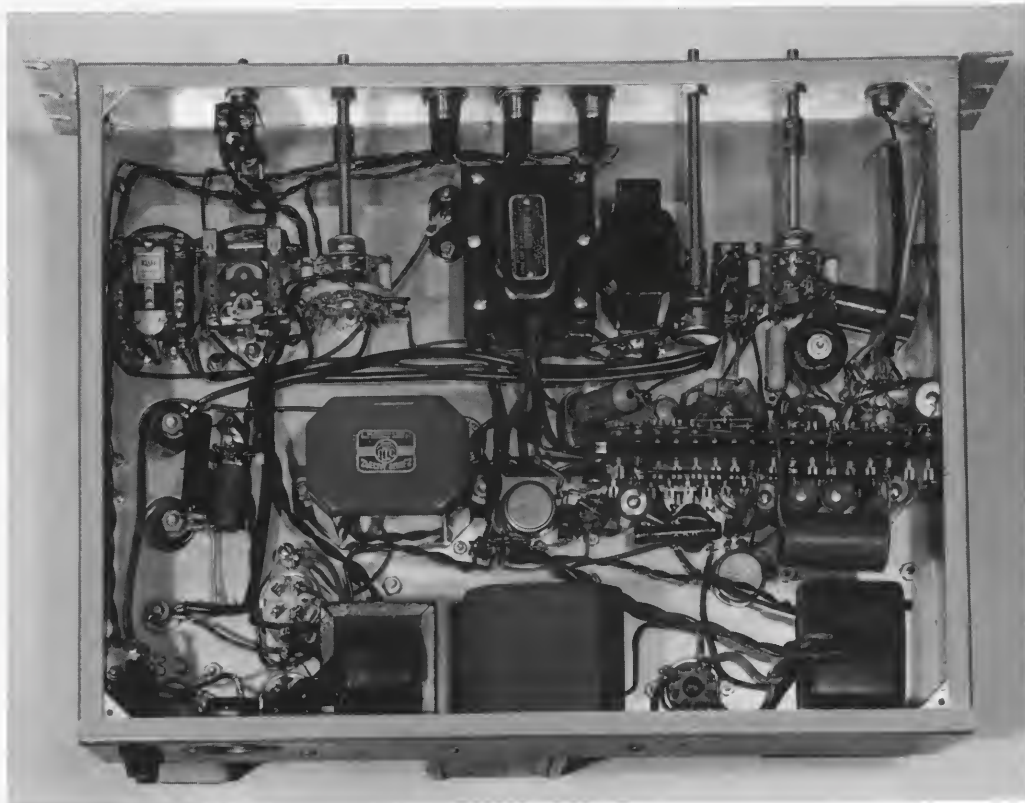

BOTTOM VIEW of the transmitter main chassis. Note the extension shafts on three of the panel controls. The doughnut-shaped coil just above the terminal boards is L_{10} , part of the audio low-pass filter. Wires carrying alternating current are twisted together wherever pos-

sible. Although the schematic diagram in the last issue showed all tube heaters operating from the 6.3-volt winding on T_4 , this model has a separate transformer for all the heaters in the r.f. unit, located just to the left of T_1 , and close to P_1 above the chassis.

INITIAL ADJUSTMENT and tuneup, as outlined on pages 6 and 7 of the May-June, 1959 issue, should first be completed. Normal tuneup when operating the transmitter into a dummy, or "live" antenna, is quite simple.

First, set S_3 in the TUNE position and adjust C_3 and C_6 for maximum grid current in the 6146 stage, with the meter switch (S_4) in position 4 or 5. Then, turn S_3 to the TRANSMIT position, S_6 to the SINE WAVE position, and S_4 to position 9. Adjust the 500,000-ohm potentiometer in the grid of V_{10A} so that the meter (M_1) reaches about half scale when C_7 , C_9 and S_3 are adjusted for maximum meter reading.

Check the signal frequently, both with tone modulation, and with voice modulation, to ensure that the 6146 balanced modulator is operating properly without "flat-topping." For a discussion of the correct and incorrect scope patterns produced by a DSB transmitter, refer to "DSB Considerations and Data," *CQ* magazine, October, 1957, page 64. This article was written by Dale S. Harris, K3CBQ, of G-E's Heavy Military Electronics Department.

MAY-JUNE, 1959 (Vol. 14, No. 3) ISSUE--

200-WATT DOUBLE SIDEBANDER--PART I. PART II Appeared in the July-August, 1959 Issue.

COMMENTS--

This section contains a revised schematic diagram larger in size than that on pages 4 and 5 of the May-June, 1959 issue, and additional notes on components and operation of the 200-watt Doublesidebander.

A. SCHEMATIC DIAGRAM REVISIONS

1. Both cathodes of V_8 (V_{8A} on pin 3; and V_{8B} on pin 8) should be connected together with a dot where the lines cross. This completes the DC cathode return path for V_{8A} and places the 25-mfd, 25-volt capacitor across the 330, and two 620-ohm resistors in series with the cathode return lead for V_{8B} .
2. The cathode resistor for V_{10B} , not marked on the original diagram, is 680 ohms.
3. The capacitor in the grid circuit of V_{10B} , between the 150,000-ohm resistors, not marked in value, is 0.001 mfd.
4. The resistor between the 2,700-ohm cathode resistor for V_{10A} and the 10,000-ohm potentiometer (TONE FREQ.) not marked, is 43,000 ohms.
5. The r.f. choke in series with the cathode of V_5 , RFC₆ on the diagram, is 2.5 millihenries, the same value and type as RFC₁.
6. The resistor between the cathode of V_5 and the "RF OUT" tap on S_{4B} , next to a 0.01-mfd capacitor and not marked, is 39,000 ohms.
7. The resistor in the exciter plate voltage lead between L_0 and the "B + 400 V." tap on S_{4B} , not marked is 200,000 ohms. (two 100,000-ohm, 1/2-watt resistors in series).
8. The full-scale current reading on the meter, M_1 , with S_4 in position 3 (Driver Cathode Current) should be 40 ma., with the 51-ohm resistor in series with the cathode of the 6CL6 (V_5). For a full-scale meter reading of 50 ma., change this 51-ohm resistor to 39 ohms.
9. Only two pilot lamps, I_1 and I_2 , are shown on the schematic diagram, although three lamps are shown in the front view picture on page 3 of the May-June issue. This extra pilot lamp actually was connected across the primary of T_3 and lit only when power was actually being applied to T_3 . The switch S_5 was wired somewhat differently, so that when K_1 closed, I_2 would light in the "TUNE" position, indicating that sufficient grid drive to the 6146's was available to permit application of high voltage when S_5 was turned to the "TRANSMIT" position.

B. COMPONENTS

1. Any audio driver type transformer having a center-tapped primary and secondary, with a turns ratio of 4 to 5, primary to 1/2 of the secondary, and capable of handling 25 milliamperes of current in the windings, should be suitable. The winding marked as the "primary" on the transformer should be connected as the secondary, driving the 6146 screen grids in this application. The transformer actually used in this transmitter was a Merit No. A-3123. A Thordarson type 20D80 also is suitable, as is any small multi-match type driver or modulation transformer with which the proper turns ratio can be obtained.
2. A 5763 pentode can be substituted for the 6CL6 driver by changing pin connections on the socket to match those for the 5763.
3. Bandswitching could be added to the exciter instead of the plug-in coils, but this would require a complete revision of the mechanical layout. For single knob bandswitching, layouts similar to those used in some of the commercially built transmitters, with 6146's in the final, could be followed.

DOUBLE SIDEBAND JUNIOR

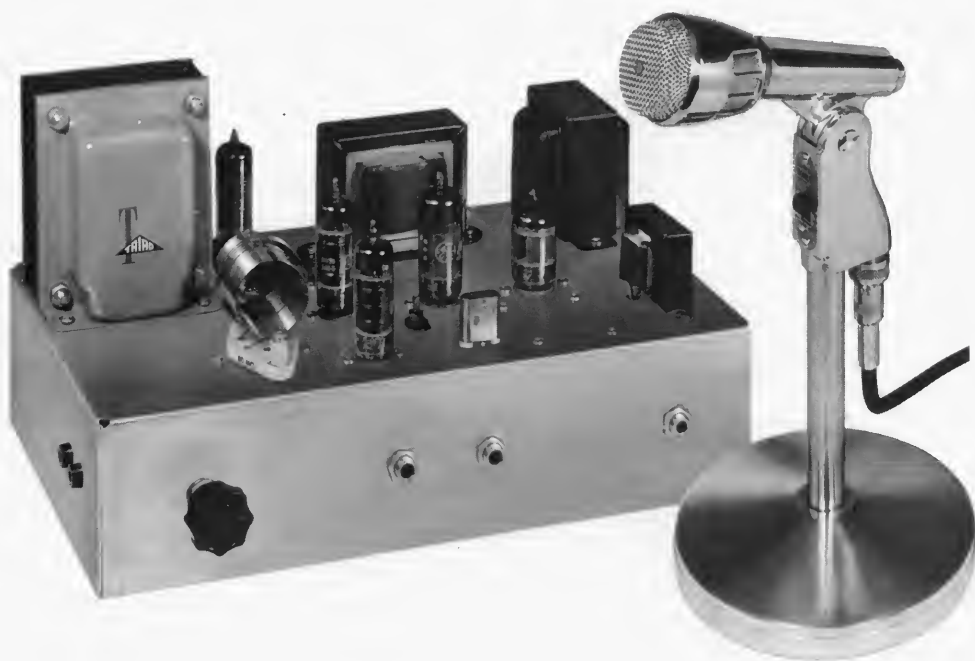

A 20-WATT DSB TRANSMITTER FOR 3.8-4.0 MEGACYCLES

Get started on rapidly growing double sideband with this simple, junior-sized—but complete—transmitter designed by K2GZT (ex-WφAHM). If this little rig looks familiar, you're one of literally thousands of radio amateurs who have examined it personally at ARRL conventions, and club meetings, during the past several months.

—Lighthouse Larry

To say that radio amateurs have been expressing considerable interest in the double sideband, suppressed carrier communications system could easily be the understatement of the year. This has been obvious from the wealth of articles on the subject in recent electronics journals (see bibliography on page 8); also from the steady flow of requests for more information on double sideband in Lighthouse Larry's mail box.

This has resulted in the design of a simple, low-cost double sideband transmitter in which several desirable features have been included. The peak power input capability is about 20 watts, sufficient for putting a respectable signal directly into an antenna; or as a driver for a higher powered linear amplifier.

Before describing the transmitter, let's first examine double sideband as a communications system, which will reveal that the following benefits may be obtained:

1. Double sideband is a suppressed carrier system. This is another step toward eliminating heterodyne interference—and the final amplifier power capability is not wasted on a carrier¹.
2. Since the output waveform is a replica of the modulating waveform, speech clipping may be employed to increase the average intelligence power.
3. A double sideband transmitter is quite inexpensive and simple compared to either amplitude modulated or single sideband equipment².
4. Modulation may be accomplished at the operating frequency.
5. Frequency diversity is inherent in the double sideband system. (The receiving operator has his choice of the more readable of two sidebands.)³
6. Double sideband can be received with either a single sideband or synchronous detection receiver. Therefore, it is compatible with single sideband. The synchronous receiver eases transmitter stability requirements by phase locking to the double sideband signal⁴.

CIRCUIT DETAILS

In a double sideband transmitter, the modulation process occurs in an amplifier using two tetrode or pentode tubes, called a balanced modulator. Recently published double sideband modulator circuits—a typical diagram is shown in Fig. 1—have shown the RF driving signal applied to the control grids in push-pull; and the audio modulating signal to the screen grids in push-pull. The tube plates are then connected in parallel to cancel out the RF carrier. This circuit is particularly suited to high power balanced modulators, since an expensive high voltage split-stator variable capacitor is not required in the plate circuit.

Examination of the schematic diagram for the DOUBLE SIDEBAND JUNIOR transmitter, Fig. 2, will reveal that the RF output stage consists of two Type 6AQ5 pentode tubes (V_2 and V_3) with the control grids in parallel, and the screen grids and plates in push-pull. This balanced modulator circuit was chosen because a compact receiving type two-section variable capacitor (C_1) can be used in the push-pull plate tank circuit. The RF output is link coupled from the center of the plate tank coil (L_2).

The grids are driven by a crystal controlled oscillator, one half of a 12BH7 twin triode tube (V_{1A}). The other half (V_{1B}) is the audio modulator stage. The RF output stage is screen modulated with the push-pull audio signal, transformer coupled from the modulator stage. The transformer specified for T_2 is connected backwards (primary to the screen grids of V_2 and V_3 ; secondary to plate of V_{1B}). The RF carrier signal applied in parallel to the control grids of the 6AQ5 tubes is cancelled out in the push-pull plate circuit.

With no modulation the plate current in both final tubes will be low because of the low screen voltage. If a sinusoidal audio tone is assumed as the modulating

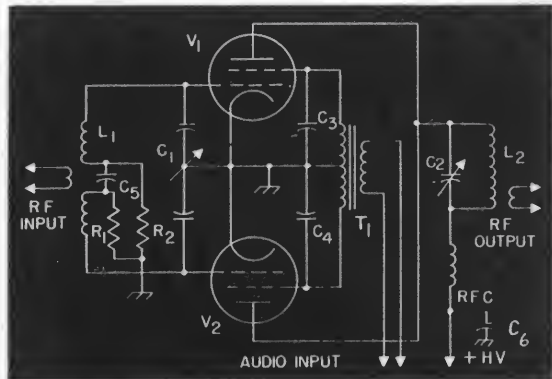

Fig. 1. Schematic diagram for the balanced modulator circuit used in most double sideband transmitter descriptions. Parts values are dependent on tube type and frequency.

signal, one screen is driven positive during the first half-cycle and the other is driven negative. The 6AQ5 having positive screen grid conducts and an RF current is supplied to the load by that tube. During the next half of the audio cycle, the other tube supplies RF power to the load and the first tube rests. Note that only one tube is working at any one time, except when there is no audio; then both tubes rest. Neutralization is no problem, as the balanced modulator circuit is self-neutralizing.

A positive bias for the 6AQ5 screen grids—about 13 volts—is developed across the 2000-ohm resistor in series with the cathode-to-chassis connection for the modulator tube (V_{1B}). Current for operating a carbon microphone is supplied through the 1500-ohm resistor.

The two audio voltage amplifier stages employ a 12AU7 twin triode (V_4). The first stage is driven by a single button carbon microphone through a matching transformer (T_3). The first audio stage drives a shunt-type diode clipper circuit which clips both positive and negative audio signal peaks. The clipping level is adjusted by varying the positive bias on the clipping diodes, D_1 and D_2 . This bias is obtained from a 1000-ohm potentiometer in series with the cathode-to-chassis circuit of the second audio amplifier stage (V_{4B}).

A simple pi-section audio filter (C_2 , C_3 and L_2) following the clipper suppresses the audio harmonics ("splatter") generated in the clipping process. The second audio stage then drives the modulator (V_{1B}).

Push-to-talk operation of the transmitter is obtained simply by grounding the cathode of the crystal oscillator tube (V_{1A}) through a single pole, single throw, normally open push-button switch of the type found on most single button carbon microphones (war surplus T-17, or Electro-Voice Model 210-KK). If the push-to-talk feature is not desired, substitute a two conductor phone jack for the three conductor jack (J_3) shown in the schematic diagram.

Additional audio amplification will be required if a low-output crystal, ceramic or dynamic microphone will be used with the transmitter in place of the carbon microphone. This extra gain can be obtained with a 12AX7 twin triode tube in a two-stage audio pre-amplifier. The circuit for this amplifier, which will deliver a voltage gain in excess of 1000, is shown in Fig. 2. The arm on the 250,000-ohm gain control at the output of the second stage (V_B) feeds directly into the grid of V_{4A} . The transformer (T_3) and carbon microphone voltage circuit can thus be eliminated.

The transmitter may be constructed with the high voltage power supply shown in the main schematic

diagram; or, any separate power supply capable of delivering 400 volts at 70 ma may be used instead. A lower plate supply voltage will result in reduced RF power output from the transmitter.

The transmitter may be operated in mobile service with a PE-103 dynamotor as a plate power supply. The microphone control circuit should be connected to switch the dynamotor rather than the oscillator.

If operation on other bands is desired, it will be necessary to change only L_1 and L_2 . L_1 should be self-resonant at the crystal frequency and L_2 should be a conventional balanced tank coil for the band in use. The transmitter may be operated on two bands, as it is possible to double in the final amplifier. For example, if an 80-meter crystal and a 40-meter tank coil (L_2) are used, the output will be in the 40-meter band. This method of operation is not highly recommended, but only mentioned as a possibility.

No special effort has been made to achieve a high order of carrier suppression. However, laboratory meas-

urements indicated 40 db of suppression in the original model. At least 30 db of carrier suppression should be obtained with reasonably symmetrical wiring in the RF output circuit. In most cases, the audio hum and noise level will be about equal to the carrier level.

MECHANICAL DETAILS

The transmitter shown on page 1 was constructed on a 7 x 12 x 3-inch aluminum chassis (Bud AC-408). A smaller chassis, or utility box, will easily hold the RF and audio components, especially if the power supply is constructed on a separate chassis. Of course, if a suitable high voltage supply already is available, utilize it instead.

The same relative locations for major parts, as shown in the chassis drilling diagram, Fig. 3, should be followed. If the audio preamplifier for low output microphones is to be included, the tube socket should be placed in the location indicated on this diagram. The

PARTS LIST—DOUBLE SIDEBAND JUNIOR

- C_1 ... two-section variable, 7—100-mmf per section (Hammarlund MCD-100S or equivalent)
- C_2 500-mmf, 500-volt mica
- C_3 300-mmf, 500-volt mica
- C_4, C_5, C_6 25-mfd, 50-volt electrolytic
- C_7, C_8 40-mfd, 450-volt electrolytic
- C_9 16-mfd, 450-volt electrolytic
- D_1, D_2 1N63 germanium diodes (G-E 1N63)
- J_1, J_2 two-conductor, closed-circuit phone jack
- J_3 three-conductor, open-circuit phone jack
- L_1 ... 15 μ h, 50 turns, No. 28 enameled wire, scramble wound $\frac{1}{4}$ of an inch long on a $\frac{3}{8}$ -inch diameter iron slug-tuned coil form (CTC LS-3)
- L_2 ... 44 μ h, 48 turns, No. 22 wire, $1\frac{1}{2}$ inches long, $1\frac{1}{4}$ inches in diameter, with 3-turn link at center (B&W 80JVL)
- L_3 ... 6 henry, 40-ma, 300-ohm iron core choke (UTC R-55 or equivalent)
- L_4 ... 14 henry, 100-ma, 450-ohm iron core choke (UTC R-19 or equivalent)
- R_1 1000-ohm, 2-watt potentiometer

- R_2 3100-ohm, 5-watt wire-wound resistor
- R_3 250,000-ohm potentiometer, audio taper
- $RF C_1$25 mh RF choke
- S_1 single pole, single throw toggle switch
- T_1 ... Power transformer, 880 volts center tapped, 75 ma DC, four 6.3-volt heater windings, 115-volt, 60 cycle primary (Triad R-70A or equivalent) (6 X 4 rectifier heater should be powered from separate 6.3-volt winding on T_1 .)
- T_2 ... driver transformer, turns ratio 5.2 to 1, primary to $\frac{1}{2}$ secondary; connect primary as secondary and vice versa.) (Thordarson 20D79 or equivalent)
- T_3 ... line or single button carbon microphone-to-grid transformer, turns ratio 31.4 to 1. (Triad A-1X)
- V_1 12BH7A tube
- V_2, V_3 ... 6AQ5 tube (G-E types 6005 Five-Star, or 6669 Communication series, also suitable)
- V_4 12AU7 tube
- V_5 6X4 tube (5Y3-GT if T_1 has 5-volt winding)
- V_6 12AX7 tube (optional audio amplifier)

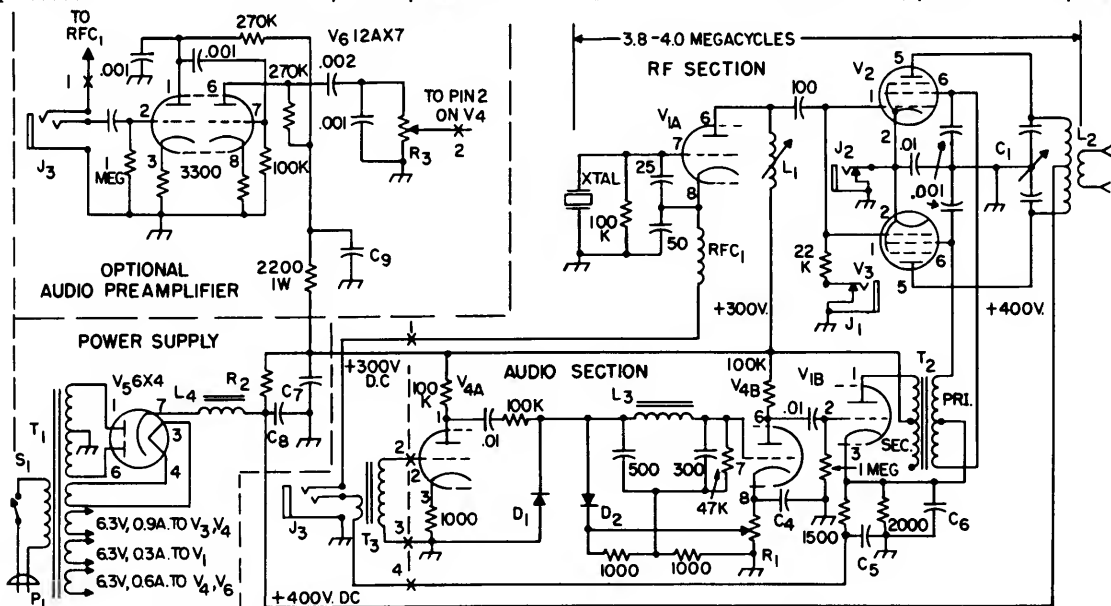

Fig. 2. Schematic diagram for the complete 20-watt double sideband transmitter. The high voltage power supply, shown within dotted lines, may be eliminated if a suitable supply already is available. The optional audio preamplifier appears in the upper left-hand corner. Capacitances given in whole numbers are mica, 500 volts working; those in decimals are disc ceramic, 500 volts working. Resistors are $\frac{1}{2}$ watt unless otherwise specified.

DRILLING LEGEND

- "A" drill—No. 32 for miniature tube socket hardware.
- "B" drill—No. 26 for fastening terminal strips and larger components.
- "C" drill— $\frac{9}{32}$ of an inch in diameter for L_1 .
- "D" drill— $\frac{3}{8}$ of an inch in diameter for controls, grommets, etc.
- "E" socket punch— $\frac{3}{8}$ of an inch in diameter for 7-pin miniature tubes.
- "F" socket punch— $\frac{3}{4}$ of an inch in diameter for 9-pin miniature tubes and grommet under T_1 .
- "G" socket punch— $1\frac{1}{4}$ inches in diameter for L_2 .

Fig. 3. Chassis deck and front panel drilling diagram for the double sideband transmitter. Dimensions are shown from the edges of a 7 x 12 x 3-inch deep chassis. Tube sockets should be mounted with pin 1 in the position indicated at each socket hole. The socket for the optional audio preamplifier tube (V_6) and gain control (R_3) are located as shown.

Fig. 4. Top view of the double sideband transmitter, showing the locations of major parts on chassis deck. Check to see that sufficient space is provided for components which differ in size and shape from those listed. The audio filter inductor (L_2) and the microphone transformer (T_3) should be oriented in the positions shown to prevent inductive hum pickup from the power transformer (T_1).

Fig. 5. Bottom view of the chassis, showing placement of smaller parts on the tube sockets and terminal strips. Power wiring is run in corners and across the center of the chassis. Wires carrying audio and RF voltages should be made as short as possible.

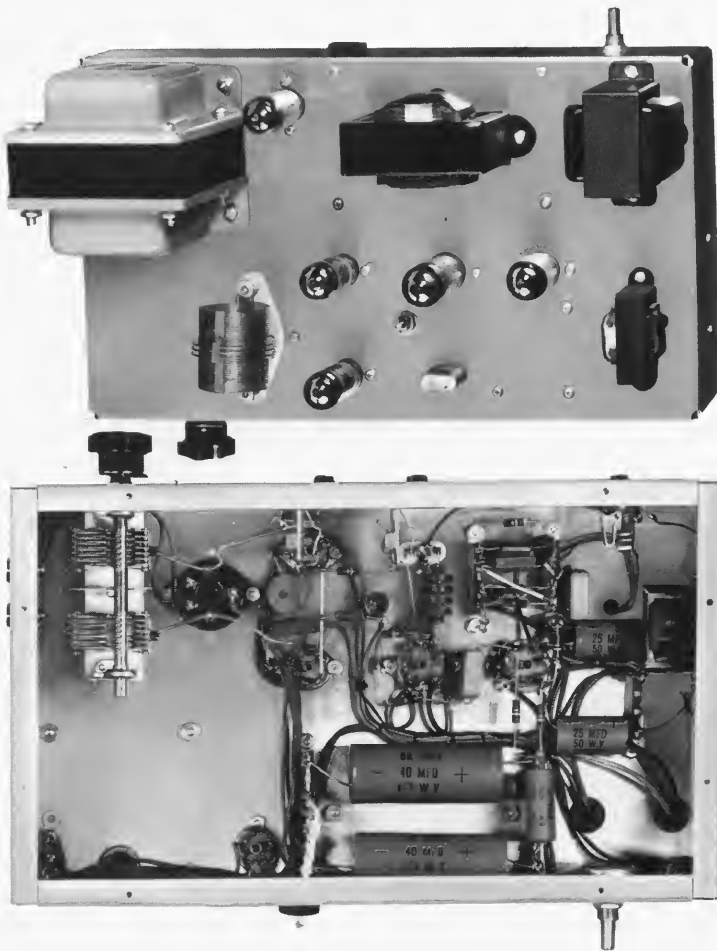
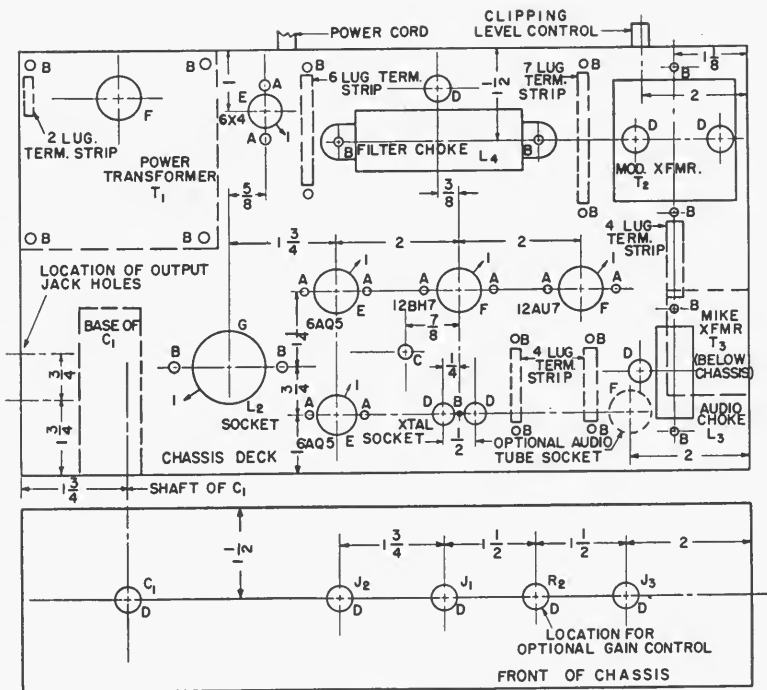

matching transformer for a carbon microphone, T_3 , is then not required. The audio low-pass filter inductor, L_2 , should be mounted beneath the chassis in place of T_3 . The gain control between stages in the extra audio amplifier may be mounted midway between J_1 and J_3 on the front of the chassis, as indicated on the drawing.

Small holes for component fastening hardware should be located directly from the matching holes on each part; the drilling diagram simply indicates the presence, but not the precise location, of these holes. Rubber grommets should be placed in all chassis holes for transformer leads before these parts are assembled in the locations shown in the top view photo, Fig. 4.

The smaller parts beneath the chassis are fastened between tube socket lugs and lugs on other parts, or on lug-type terminal strips (Cinch-Jones 2000 series). Most of the audio clipper and low-pass filter components were assembled between two four-lug strips, as shown in the bottom view photo, Fig. 5. Note that the tubular type electrolytic filter and cathode bypass capacitors fit neatly into unused portions of the chassis. Use of metal can type capacitors will require crowding of some components on the chassis deck.

All power and audio circuit wiring was run with No. 20 stranded, insulated hookup wire. Heavy tinned copper wire was used for the lead between the 6AQ5 control grid socket pins; also for connecting the 6AQ5 plate lugs to the socket for L_2 and stators on C_1 . Small insulated banana jacks were mounted on one end of the chassis for antenna terminals, but a suitable chassis type coaxial cable connector may be substituted.

The audio preamplifier stage, which may be added to the transmitter at any time, was constructed on a turret type 9-pin miniature socket (Vector No. 8-N-9T), as shown in the photo of Fig. 6. There is adequate room on this socket for all small parts, but the 16-mfd, 450-volt filter capacitor in the plate voltage decoupling filter should be placed in the corner behind T_3 .

ADJUSTMENT AND OPERATION

Once the transmitter has been completed, it should be tested on a dummy load consisting of a 15- or 25-watt, 115-volt incandescent lamp bulb. The test procedure consists of the following steps:

1. Apply power and insert a crystal for the 3.8-4.0-megacycle phone band. Depress the microphone push-

to-talk switch.

2. Adjust L_1 to resonance while observing the final amplifier grid current on a milliammeter inserted at J_1 . A grid current of 3 to 4 milliamperes is required for proper operation.

3. Set R_1 to its midpoint. Adjust L_2 for closest coupling. Whistle into the microphone and adjust C_1 for maximum output power or maximum brilliance of the dummy load lamp.

4. Observe the RF output voltage with an oscilloscope. Either the bowtie or envelope presentation may be used¹. Whistle into the microphone. Successively adjust the output coupling and clipping level (R_1) for maximum output voltage consistent with *linearity*⁶.

5. Upon successful completion of testing with a dummy load, the transmitter may be connected to a transmitting antenna. The antenna should preferably be a low impedance tuned antenna, such as a dipole or folded dipole. If a long wire antenna is used, an antenna tuner should be used to transform the antenna impedance down to a value suitable for link coupling. When the transmitter is connected to the antenna, step 4 should be repeated to ensure that the output stage is properly adjusted and not overloading on positive audio peaks. The final amplifier cathode current may be metered at J_2 . The plate current will have a resting value of about 20 ma and will rise to about 40 ma with modulation.

Although the basic transmitter is crystal controlled, the output of a variable frequency oscillator may be fed into the crystal socket with a short length of 300-ohm twinlead. It is important that this external oscillator have an isolating stage between it and V_{1A} to prevent frequency modulation of the signal. The VFO also should have good long-term frequency stability. Otherwise, the other participants in a round-table QSO will keep reminding you to get back on frequency.

DOUBLE SIDEBAND JUNIOR has sufficient RF output to drive a pentode linear amplifier in the one-kilowatt power class; or a triode linear amplifier in the 400-watt class, such as the LAZY LINEAR (See *G-E HAM NEWS*, July-August, 1949, Vol. 4, No. 4, for details). But even when operated "barefooted," it should have a normal working range of several hundred miles on the 3.8-megacycle band.

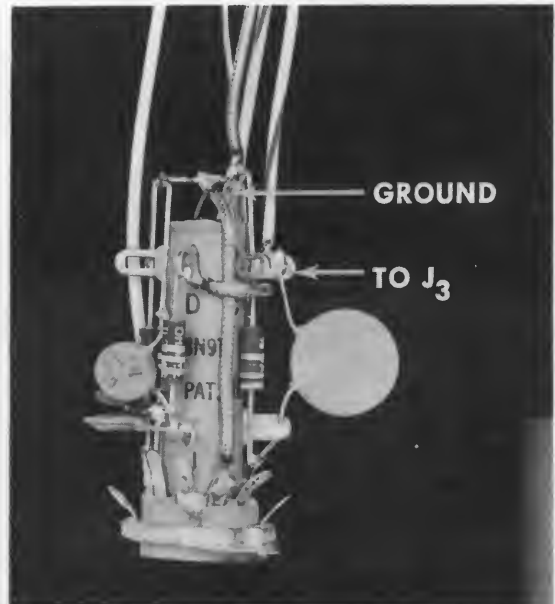
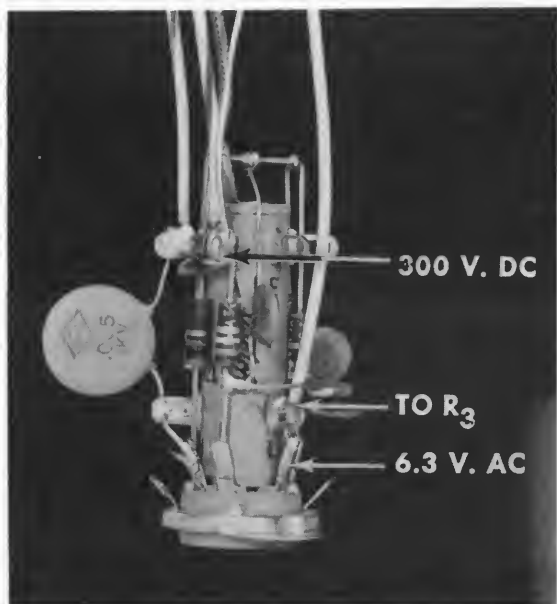

Fig. 6. Detail views of the audio preamplifier stage constructed on a turret type 9-pin miniature tube socket (Vector No. 8-N-9T). Terminals to which external connections are made have been labeled.

Added Information for Double Sideband Junior Transmitter

The following suggestions have been compiled to aid those persons who may wish to place the Double Sideband Junior transmitter on other bands, connect a VFO to it; or for those who require trouble-shooting information:

1. **HEATER CIRCUIT** -- The three separate 6.3-volt AC heater windings shown in the schematic diagram, Figure 1, on page 2, happened to be on the power transformer (T_1) actually used on the model transmitter. Of course, if another type of power transformer is substituted for the Triad No. R-70A, the heaters of V_1 , V_2 , V_3 and V_4 all can be powered from the same heater winding. The 6X4 rectifier tube heater should be powered from a separate 6.3-volt transformer winding. If the power transformer has a 5-volt winding, it probably will be more convenient to substitute a type 5U4-GB full-wave rectifier tube for the 6X4.
2. **HIGH VOLTAGE POWER** -- Although a capacitor-input type filter may be used on the high voltage supply if a fairly low resistance bleeder resistor is used to place a fairly high static current drain on the power supply, the choke-input type filter shown in our schematic diagram is recommended. The voltage regulation of a choke-input filter is much better, resulting in improved linearity in the balance modulator stage.
3. **6AQ5 PLATE VOLTAGE** -- The power output from the 6AQ5 balanced modulator stage will drop rapidly as the plate voltage is reduced below 400 volts. Actually, the DSB Jr., will deliver about 35 percent more power output with 500 volts on the plates, than with 400 volts. We cautioned users of this circuit against running more than 400 volts on the 6AQ5's in G-E HAM NEWS, but the tubes will easily handle 500 volts in DSB service. However, we have not tested the 6AQ5 stage at higher voltages -- say 600 volts -- even though they may withstand this voltage without breaking down. The combined plate dissipation of two pentode-connected 6AQ5's is 24 watts. This indicates that the tubes will handle up to 60 milliamperes of plate current with 400 volts on the plates without being overloaded, even though the tubes may not be delivering any RF output power, which might happen with the plate tank circuit tuned far off resonance. The higher-than-normal plate voltage rating follows the usual practice of operating tubes in a DSB balanced modulator at double the plate voltage rating for class C plate modulated RF amplifier service.
4. **DUMMY LOADS** -- The usual 50-ohm non-inductive resistors, or a 15 or 25-watt, 115-volt lamp bulb will provide a suitable dummy load resistance for the DSB Jr. With 400 volts on the 6AQ5's, a 15-watt lamp should light to nearly full brilliancy before non-linearity occurs in the 6AQ5 stage, especially when several

- db of clipping is being employed in the audio circuit. A 25-watt lamp should show about 2/3 of normal brilliancy (about what it would show with 80 volts AC applied to it).
5. **OUTPUT TANK CIRCUIT --** The 6AQ5 plate tank circuit, C_1 -- L_2 , should tune to resonance at 3.8 megacycles with C_1 near maximum capacitance. If it will not tune this low in frequency, add a small padding capacitor -- a 10 mmf, 2000-volt working mica is suitable-- across the ends of L_2 on the plug-in coil base. This tank circuit should tune to the 7-megacycle band with C_1 set near 45 degrees of rotation from minimum capacitance.
 6. **OPERATING DSB JR. FROM A VFO --** It was possible to feed the output from a Heathkit VFO directly into the crystal socket of the DSB Jr., on the 3.8 megacycle band, with good results. The connection may be made with a short length of RG-58/U coaxial cable. The triode oscillator circuit, acting as a buffer stage, did not go into oscillation. However, instability in this stage may be encountered with other types of VFO's. Make sure that the outer shield on the coaxial cable connects to the grounded terminal on the crystal socket.
 7. **OPERATION DSB, JR. ON OTHER BANDS --** The following coil table has been compiled (using our trusty Lightning Calculator) as a suggested means of operating DSB Jr. on higher frequencies than the 3.8 megacycle band for which it was designed. The recommended crystal frequencies should be used for each band:
 - 7-MC BAND --
 - Crystal--7.204 to 7.296 megacycles. (In United States).
 - L_1 --8.5 uh; 40 turns, No. 28 enameled wire, closewound 5/8 of an inch long on a 3/8-inch diameter CTC LS-3 iron slug-tuned coil form.
 - L_2 --16 uh; B & W type JVL-40 manufactured coil.
 - 14-MC BAND --
 - Crystal--14.204 to 14.296 megacycles.
 - L_1 --3.7 uh; 27 turns, No. 28 enameled wire, closewound 3/8 of an inch long on an LS-3 form.
 - L_2 --2.2 uh; B & W JVL-15 coil.
 - 21-MC BAND --
 - Crystal--21.254 to 21.446 megacycles.
 - L_1 --2.2 uh; 18 turns, No. 24 enameled wire, closewound 3/8 of an inch long on an LS-3 form.
 - L_2 --2.2 uh; B & W JVL-15 coil.
 - 28-MC BAND --
 - Crystal--28.504 to 29.696 megacycles.
 - L_1 --1.2 uh; 10 turns, No. 24 enameled wire, closewound 5/16 of an inch long on an LS-3 form.
 - L_2 --1.2 uh; B & W JVL-10 coil.
 8. The DSB, Jr. 6AQ5 balanced modulator circuit should work on 50 megacycles when driven by a small crystal controlled exciter, such as those described in the May-June, 1958 issue, under "PACKAGED VHF EXCITERS".
 9. About plus 10 volts should be measured at the junction of C_5 and the 1,500-ohm resistor in the cathode of the 12BH7A modulator tube. This supplies excitation voltage for a carbon microphone, and may drop to about plus 5 volts with a microphone plugged into J_3 .

K2GZT'S 6146 DOUBLE SIDEBAND TRANSMITTER

There have been many requests received from radio amateurs for information on the 7-megacycle DSB transmitter using a pair of 6146's, as mentioned on page 8 of the March-April, 1958 issue of G-E HAM NEWS. The schematic diagram below shows the balanced modulator circuit he is using, with the major component values marked thereon. The operating conditions for the 6146 tubes are listed below. Note that the plate voltage--1200 volts--is much higher than the usual maximum rating, but is in line with the usual practice in a DSB balanced modulator of operating the tubes at a DC plate voltage twice the recommended plate voltage for plate-modulated class C amplifier service. Thus, the 1200-volt value is equal to the positive peak modulating voltage.

AUDIO MODULATOR CIRCUIT -- A

two-stage modulator circuit is shown in Fig. 1. Inverse feedback voltage from the plates of the 12BH7 push-pull output stage is fed into the cathodes of the 12AT7 driver stage to reduce audio distortion. The 12AT7 should be preceded by a phase-splitter stage having about 1 volt peak-to-peak output. Audio clipping and low-pass filtering, as shown in the original DOUBLE SIDEBAND JUNIOR circuit, may be used for increased average power output from the 6146 balanced modulator.

MECHANICAL LAYOUT, 6146 DSB BALANCED MODULATOR--The usual practice of short leads in the RF circuitry should be followed during construction of the modulator stage. The final amplifier layout for any of the popular 100-watt class transmitters (DX-100, Valiant, etc.) may be used as a guide for this circuit.

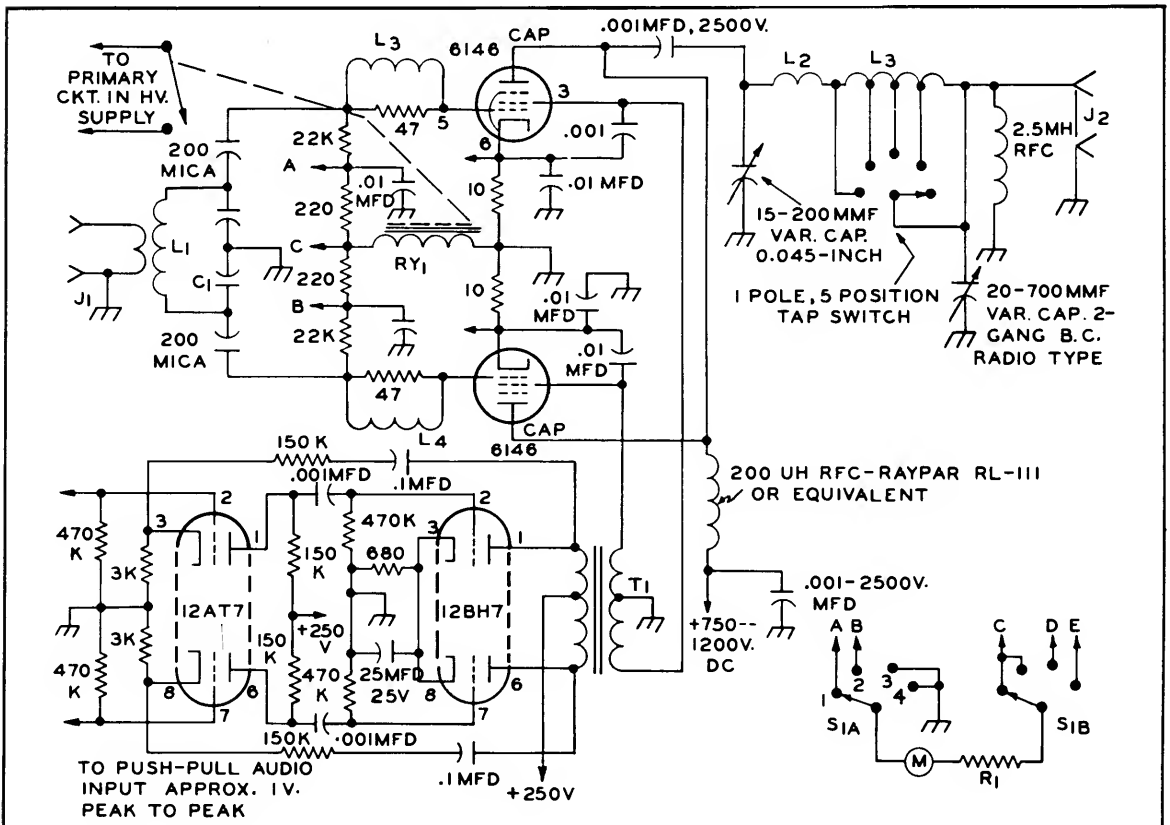

TABLE I — PARTS LIST

- C_1 -----10--100--mmf per section, two-section receiving type variable.
 J_1, J_2 ----chassis type coaxial cable connectors.
 L_3, L_4 ----VHF parasitic suppressors; 6 turns, No. 16 enameled space wound on 1/4-inch diameter, 47-ohm, 2-watt resistors.
 M -----low-range milliammeter, see TABLE I.
 R_1 -----Value depends upon full-scale current rating of meter, see TABLE I.
 RY_1 -----SPST relay with 3-ma DC coil.
 S_1 -----two-pole, four position tap switch.
 T_1 -----audio driver transformer, turns ratio 5.2 to 1, primary to 1/2 secondary (Thordarson No. 20D79); connect primary as secondary, and secondary as primary.

TABLE II — COIL TABLE

BAND	L_1	L_2
3.5 MC:	B & W MCL-80 coil:	L_2 ---6.5 uh, 18 turns, No. 16 wire, space-wound 8 turns per inch, 2.1/4 inches long, 1 1/2 inches in diameter.
7 MC:	B & W MCL-40 coil:	L_2 ---3.2 uh, 13 turns, No. 16 wire, space-wound 6 turns per inch, 2 1/6 inches long, 1 1/2 inches in diameter.
14 MC:	B & W MCL-15 coil:	L_2 ---1.6 uh, 9 turns, No. 14 wire, space-wound 4 turns per inch, 2 1/4 inches long, 1 1/2 inches in diameter.
21 MC:	B & W MCL-15 coil:	L_2 ---1.08 uh, 7 turns, No. 14 wire, space-wound 4 turns per inch, 1 3/4 inches long, 1 1/2 inches in diameter.

TABLE III — METER RANGES

METER RANGE	R_1	FULL SCALE READINGS	
		GRID	CATHODE
0--1 ma.	1000 ohms	4.5 ma.	100 ma.
0--1 ma.	470 ohms	2.2 ma.	50 ma.

TABLE IV — 6146 OPERATING CONDITIONS — DSB MODULATOR

DC Plate Voltage	1200 volts
DC Screen Voltage	0 volts
DC Control Grid Bias	0 volts
DC Plate Current (no audio signal on screens)	25 milliamperes
DC Plate Current (maximum for good linearity)	100 milliamperes
Peak Envelope Power Input	170 watts
Peak Envelope Power Output	125 watts

The trend by more and more amateurs to suppressed carrier phone communications is one of the greatest things that has ever happened to amateur radio. It is really a pleasure to operate in the segments of the bands which the sidebanders have pretty well taken over.

DSB offers a very easy way for anyone to try out suppressed carrier operation and it is hoped that this discussion will encourage more of you to try it. Let us not get off into any AM versus SSB versus DSB arguments—those arguments are for the professionals and the average amateur should steer clear.

Several DSB articles have appeared in recent issues of CQ showing the basic tetrode balanced modulator circuits used to suppress the carrier. These circuits may have either of two configurations:

1. Push-pull grids with parallel plates, or
2. Parallel grids with push-pull plates.

In either case, the screens are modulated with push-pull audio. Generally, the first configuration will be the best one to use since the push-pull components will be small and a pi-tank can be used in the output, the advantages of which are well known.

Hi-Level vs Linear

There are two approaches to medium or high power DSB. One is to make your final a high power balanced modulator. The other would be a low-power balanced modulator driving a linear amplifier. Unless you already have a *linear* amplifier (and know how to keep it linear) the high level approach is definitely recommended. If you do use a linear, don't forget that a single audio tone to the DSB exciter is a two-tone signal into the linear amplifier!

Most CW exciters have plenty of output to drive even the big tetrodes in a DSB final. Anyone with a two tube final (either push-pull or parallel) will only have to modify one RF circuit and split the screen grids to put the final on DSB.

Most any tetrodes may be used in the balanced modulator circuit and a tabulation of the recommended variables for the more common tubes is presented later. The general considerations of how to operate different tubes are best discussed one circuit at a time.

Grid Circuit

Each tube should definitely have its own grid bias resistor. Attempts at using a common bias resistor have resulted in aggravating any off-balance tendencies the tubes may have. The grid circuits should be operated as for nor-

mal class C Plate Modulated operation. The normal bias resistors for class C are used. The grid current is run up to normal values. It has considerable effect upon the resting plate current.

Bias may be partially from a battery, but should not be all battery bias. Partial battery bias will be found very handy if you want to include voice control operation.

Screen Circuit

The dc bias applied to the screens through the modulation transformer secondary has two effects. Most important is its effect upon the bow tie pattern crossover point. Just enough negative bias should be used to give a clean crossover and limit the resting plate current. Any further negative voltage will cause the two halves of the pattern to separate apart indicating distortion. The screen bias is necessary on some tubes to hold down the resting plate dissipation requirements. The bias battery or supply should have good regulation and should be by-passed heavily with several microfarads of capacitance. The smaller tubes (807's, 6146, etc.) work nicely with zero screen bias.

The screens must be by-passed for rf but not for audio, so the by-pass condensers should not be larger than .001 mfd and should be mica. The audio swing of the screens determines the amount of plate current the tubes can draw. As a conservative estimate of how much audio voltage you will need, take the normal plate modulated screen voltage and double it. Your audio *peaks* should hit this value (from center tap of mod. xfmr to screen) If you really want to run to full tube capability, you can check by heavily loading the final and running up the audio voltage till the RF no longer increases with increasing audio. At this point you are flattening on peaks because of emission limitation. Exceeding that audio voltage will only cause distortion. This maximum screen swing will be the same for a given tube type regardless of what plate voltage you run.

The screen modulator needs relatively small power output, but to modulate the larger tubes, voltage swings of about 800 volts peak are required. This is best accomplished with a step-up transformer. A pair of 6L6's in Class AB1 will modulate most any tubes, but step-up transformers with push-pull primary and secondary are a scarce commodity. The best solution available now seems to be to use a 10 or 20 watt class B driver transformer of 5:1 (pri to ½ sec) step down ratio. Using it backward will give you 1:1.25 primary to one-half secondary.

Before long perhaps the transformer manufacturers will make available more suitable transformers.

Another possibility is to use a single 6L6 into the 117 volt winding of a small power transformer. This will give you roughly a 1:3 step up to half of the HV winding and works quite well.

Clipper-filter

While talking about modulators, it should be pointed out that speech clipping can be used to good advantage in DSB and is a very worthwhile feature to put in the speech amplifier. Clipping will give you a big boost in average talk power. Just remember to reduce low frequency response before the clipper-filter, and preserve both lows and highs after the clipper-filter.

Plate Circuit

As previously mentioned, the plate current of the DSB stage is pretty well determined by the audio swing on the screens. The way to more power then is obviously higher plate voltage. Bearing in mind that on normal AM the plate voltage swings up to twice the dc plate voltage, you can use up to twice the AM plate voltage on your DSB stage, and up to that value, the higher the better. Any given tube will work satisfactorily at its normal plate voltage, but it's a similar situation to linear amplifiers, if you really want to sock them, you must run up the plate and screen voltages.

This means that you have the following choices based on voltages available:

- 400-600 volts 6L6's, 2E26's, 6V6's, 6Y6's
- 600-1200 volts 807's, 1625's, 6146's
- 1200-1600 volts ?
- 1600-3000 volts 813's
- 2000-4000 volts 4-125A's, 4-250A's

Paralleling tubes on each side of the balanced modulator offers a powerful little package (four 807's give 300 watts p.e.p. output), but the paralleled output capacitances may make it difficult to get above 20 meters with four tubes.

Since the plate current swing depends largely on the screen voltage swing, the best way to tune the DSB stage is not by plate current dip but by tuning for maximum output. With the tank circuit resonated, increase your loading to the maximum output point and stop. That's all there is to it. Some tank circuit conditions will cause greater plate current readings but reduced output.

The plate current meter, of course, does not read peak plate current, so if you want to figure your peak envelope power you must apply a factor. For sine wave modulation, the meter reading should be multiplied by 1.58 (1/.636). This figure and your plate voltage will give you peak envelope power input; you multiply by

about 75% efficiency to get your peak envelope power output. If you are running relatively high plate voltage on your tubes you can estimate your peak output as four times the carrier output rating for AM phone service. This is conservative estimating, however, since with the low duty cycle of speech you can get a little better than this before distortion sets in from emission limiting or instantaneous downward plate voltage hits the screen voltage level.

Half of your peak power appears in each sideband which means a 3db disadvantage compared to SSB. The ability to select the best sideband at the receiving end buys some of this back, and clipping buys even more.

Checking Patterns

Just as in AM and SSB, it's always best to check your signal with an oscilloscope. The handiest pattern for checking DSB is the familiar bow tie. Apply audio on your horizontal amplifiers and rf direct on the vertical plates. This procedure is described in the handbooks. It is recommended that the audio be taken off the secondary of the modulation transformer for minimum phase shift. The audio voltage here will be way too much for your scope input though, so rig yourself a voltage divider of 1 megohm in series with a 10K resistor and pick audio off across the smaller resistor. Your bow tie should look like fig. 1.

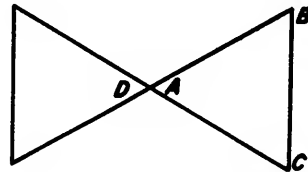

Line AB and AC should be nice and straight. The A end of these lines has a tendency to bulge slightly with too much grid drive and may become concave with too little drive, so experiment here. If you have negative bias on the screens, there will probably be a little kink near A where the screen goes through zero, but this does not cause bad distortion. Peaks at B and C should be nice and sharp. If they are rounded you are flattening and probably due to overdriving the screens. If points A and D are separated so the points don't meet, you have too much negative bias on the screens. With high plate voltage you will find it easier to get a good bow-tie pattern. If your tubes are not balanced, one half of the pattern will rise higher on peaks than the other side. One half of the pattern represents each tube, but has no relationship to the upper and lower sideband. The side-bands will be identical in any case.

The bow-tie pattern won't show up audio distortion so you will find it interesting to

6V6 6BQ6/ 807/ 6146 · 813 813 813 4-250A
6DQ6 1625

Plate Volts	500	600	1250	1000	1500	2000	2600	4000
Screen Volts	0	0	0	0	-22.5	-67.5	-90	-65
Plate Current Resting	10	25	30	25	100	55	60	80
Plate Current Full Whistle	50	150	100	125	205	245	265	300
PEP Output	30	100	150	150	380	600	840	1500

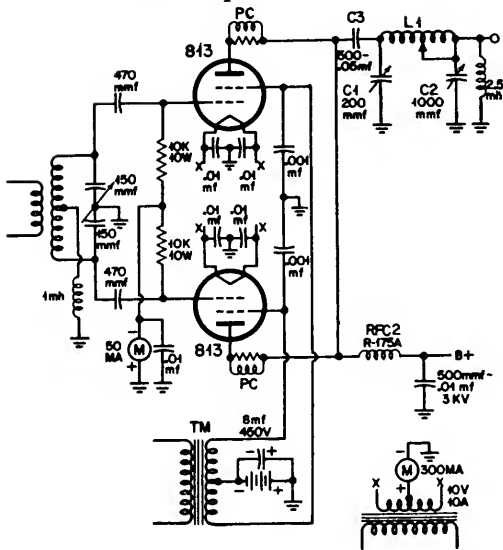

OPERATIONAL NOTES

EXCITER FOR 6146 DSB MODULATOR -- Approximately 4 to 5 watts of driving power should be available for the balanced modulator, even though the 6146's actually do not require all of this power for proper operation. The exciter output should be relatively free of spurious output frequencies, and have excellent frequency stability.

AUTHOR OF DSB JR. ARTICLE

MEET THE DESIGNER—John K. Webb, K2GZT, took a busman's holiday from his profession as electrical design engineer on synchronous and other communications systems at our Light Military Electronic Equipment Department in Utica, New York. Result—the **DOUBLE SIDEBAND JUNIOR** transmitter in this issue!

Some measure of Jack's enthusiasm for double sideband can be garnered from his many presentations on this subject at trade shows, amateur radio conventions, hamfests, and club meetings. Of course, this little transmitter usually accompanies him as his favorite "conversation piece."

First licensed as W ϕ AHM in Kansas during 1947, Jack's association with electronics includes AM broadcasting and the U.S. Army Signal Corps, before joining General Electric. Although he has tried 'em all—CW, FM, AM and SSB—Jack can now be found on 14-megacycle phone pushing a pair of GL-6146's in a— you guessed it—double sideband rig!

shift to an rf envelope pattern by switching to internal sweep on your horizontal axis. By using a steady audio note you can synchronize and see how well your audio is doing.

If you have established the proper conditions you will have a good bow-tie shape and you will be pleased to note that the tuning controls don't affect the shape much. If you detune anything, about all that happens is you get less than maximum output.

Fig. 2 is a complete circuit diagram for 813's. Exactly the same circuit is applicable for all tetrodes—you can use lower voltage components for smaller tubes of course.

Table 1 shows DSB operating conditions for some of the more common tubes. Don't worry if you don't have the exact voltages called for, these are the ones tried by W2CRR, W2HNH, W2SBI, and K2KID. Pick out the tubes you want and have a go at DSB. You'll like it!

(Continued from page II-32)

Preferably, any variable frequency oscillator used with the DSB modulator should have not more than 1-kilocycle of warmup drift during the first few minutes of operation, and should be capable of staying within 50 cycles of the desired operating frequency after the initial warmup.

BIBLIOGRAPHY OF ARTICLES ON DOUBLE SIDEBAND

- Costas, J. P., "Synchronous Communications," *Proceedings of the I.R.E.*, December, 1956.
- Costas, J. P., "Single Sideband. Is It Really Better Than Amplitude Modulation?," *CQ*, January, 1957.
- Costas, J. P., "Discussion of the Single-Sideband Issue," *Proceedings of the I.R.E.*, April, 1957.
- Webb, J. K., "A Synchronous Detection Adapter for Communications Receivers," *CQ*, June, 1957.
- Harris, D. S., "DSB Considerations and Data," *CQ*, October, 1957.
- Webb, J. K., "Modulating the DSB Transmitter," *CQ*, March, 1958.
- Eaton, R. C., "Two Sidebands for Less than the Price of One," *CQ*, September, 1957.
- Najork, Jack, "A 100 Watt DSB Mobile Transmitter," *CQ*, March, 1957.
- Stoner, D. L., "Double Sideband with the Heath DX-100," *CQ*, April, 1957.
- Jones, F. C., "Low Cost DSB-AM Amplifiers," *CQ*, November, 1957.
- Costas, J. P., "Phase-Shift Radiq Teletype," *Proceedings of the I.R.E.*, January, 1957.

HETRODYNE EXCITER WITH 6BU8 TWIN PENTODE BALANCED MIXER

HETRODYNE EXCITER ADVANTAGES:

1. No more complex than many conventional exciter circuits having a tunable oscillator, following by an isolating stage and a series of frequency multipliers.
2. Oscillator drift is the same on all bands. Drift is not multiplied as the exciter is operated on the higher frequency amateur bands, as is the case in a conventional exciter, where frequency drift at 28 megacycles can be up to 8 times higher than at 3.5 megacycles.
3. The tuning rate is the same for all bands. No switching of parallel and series capacitors is necessary in the tunable oscillator frequency determining circuits to prevent the higher frequency amateur bands from being squeezed into a small portion of the oscillator tuning dial scale.
4. Chirpless keying is simplified. Both the crystal and tunable oscillators can run continuously, but no signal will appear at the output frequency when the mixer stage is made inoperative by the keying system.
5. An adjustable negative bias can be fed to the mixer through a potentiometer, making possible setting the "zeroing in" signal in the receiver to a level which does not block or over-ride incoming signals.
6. The hetrodyne exciter can be easily adapted to single sideband operation by adding a sideband generator unit between the crystal controlled oscillator (F_2) and the mixer stage.

HETRODYNE EXCITER CIRCUIT:

The exciter, as summarized in the block diagram, consists of the solid high-c tunable oscillator signal (F_1), feeding through a link-coupled bandpass push-pull r.f. transformer into the separate No. 3 grids of a 6BU8 miniature twin pentode tube, operating as a balanced mixer. The hetrodying signal (F_2) from a crystal controlled oscillator is capacitance coupled to the common control grid for both pentode sections in the 6BU8 tube.

The two plates of the 6BU8 are connected to a push-pull tank circuit, tuned to either the sum or difference of the two input signal frequencies ($F_1 + F_2$; or, $F_1 - F_2$), and amplifies the mixer output signal (F_3). This signal drives a 6CL6 miniature pentode, operating in class A or class AB₁. The 6CL6 will deliver about 2 to 4 watts output, depending upon the output frequency.

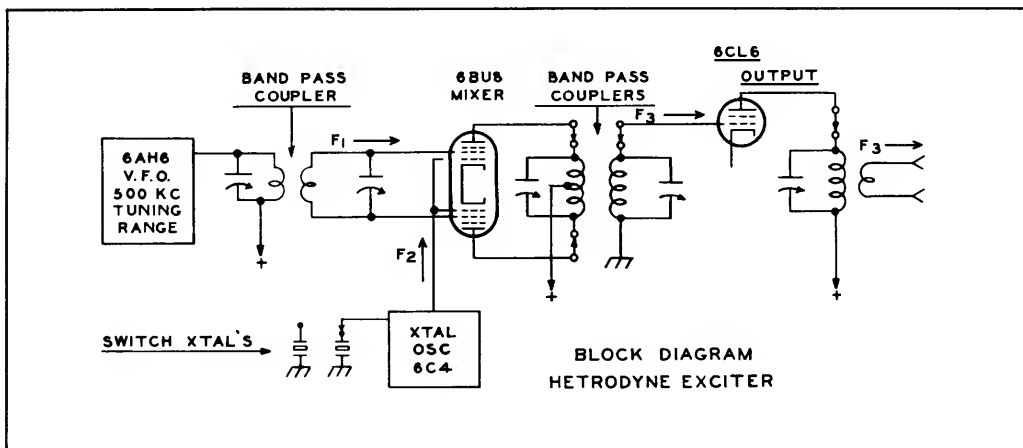

The preliminary schematic diagram of the crystal oscillator, mixer and amplifier is shown next page. Note that a ganged bandswitch (S₁A THROUGH S₁F) selects the proper crystal, oscillator plate tank coil, mixer plate circuit, and 6CL6 output circuit for the amateur bands from 3.5 to 29.7 megacycles. For simplicity, only one set of interstage coupling and output circuit coils are shown in the diagram. There are, of course, actually five sets of coils connected to switch sections S₁C, S₁D, S₁E and S₁F.

Parts values for the experimental heterodyne exciter are given in TABLE I. The chart of tunable oscillator, crystal oscillator and output frequencies for each popular amateur band are given in TABLE II. Coil data for operation of the experimental exciter on the 14-megacycle amateur band is given in TABLE III. Final coil data for L₅, L₆ and L₇, for the other amateur bands has not yet been determined, but persons interested in winding such coils should scale up and down the coil data given for 14 megacycles, keeping approximately the same L/C ratio in each tuned circuit.

The power output from the 6CL6 amplifier stage is sufficient to drive one or two of the popular 20 to 30 watt plate dissipation class beam pentode tubes in class AB₁, class B, or class C as a power amplifier (6CA7/EL34, 6DQ5, 6DQ6B, 6L6-GC, 5881, 6146, 7027, 7581, etc.). Class AB₁ operation of this 50 to 150-watt linear amplifier stage is recommended for those applications where not more than 40 watts of driving power is required by a high power amplifier stage which may follow the complete exciter. This will reduce harmonic output, as compared to operating the 50--150-watt amplifier in class C, and thus help prevent interference to nearby television receivers.

Table II · FREQUENCY CHART

(For 12-Megacycle Tunable Oscillator)

OUTPUT BAND, MC. (F ₃)	TUNABLE OSC. RANGE (F ₁) MC.	CRYSTAL FREQ. MC (F ₂)	MIXER
3.5 - 4.0	12.0 - 12.5	X ₁ = 8.5	F ₁ - F ₂ = F ₃
7.0 - 7.3	12.0 - 12.3	X ₂ = 5.0	F ₁ - F ₂ = F ₃
14.0 - 14.35	12.0 - 12.35	X ₃ = 2.0	F ₁ + F ₂ = F ₃
21.0 - 21.45	12.0 - 12.45	X ₄ = 9.0	F ₁ + F ₂ = F ₃
28.0 - 28.5	12.0 - 12.45	X ₅ = 16.0	F ₁ + F ₂ = F ₃
28.5 - 29.0	12.0 - 12.5	X ₆ = 16.5	F ₁ + F ₂ = F ₃
29.0 - 29.5	12.0 - 12.5	X ₇ = 17.0	F ₁ + F ₂ = F ₃
29.5 - 29.7	12.0 - 12.2	X ₈ = 17.5	F ₁ + F ₂ = F ₃

The final working version of this heterodyne exciter, designed, constructed and tested for a full year on all bands by W2FBS, is published in the July-August, 1961 issue of G-E HAM NEWS. It is a complete transmitter/exciter, with built-in power supply and differential keying system, and a single 7581 beam pentode in the power amplifier stage.

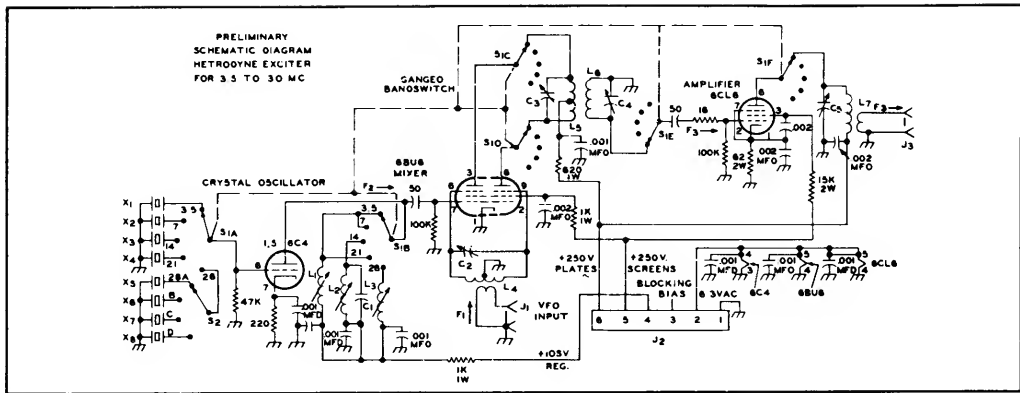

Table I · PARTS LIST

- C₁. 150-mmf mica capacitor¹
- C₂, C₃, C₄. 4--40-mmf adjustable mica trimmer capacitor² (ICA No. 611).
- C₅ 4--50-mmf air variable capacitor² (Hammarlund APC-50, or equivalent).
- J₁, J₃. chassis type coaxial cable connector; or, midget phontype jack.
- J₂. 6-pin power socket; or, 6-lug terminal strip.
- L₁ to L₇. See (Table III) COIL TABLE for details.
- S₁. 6-pole, 5 position ceramic insulated rotary tap switch (Made from Centralab P-123 index assembly and three Centralab "R" shorting type wafers spaced to suit parts layout of exciter).
- S₂. 1 pole, 4-position ceramic insulated rotary tap switch (Centralab No. 2500 6-position switch with stop set for 4 positions).

X₁ to X₈. Quartz crystals; frequencies as indicated in Table II.

¹Value across L₂ for 2-megacycle crystal, for 14-megacycle operation.

²Value required for 14-megacycle operation; capacitance will be larger for 3.5 and 7 megacycles, and smaller for 21 and 28 megacycles.

TABLE III · COIL TABLE

(For 12-megacycle tunable oscillator and 14-megacycle output)

- L₁. 6---13 uh, coil scramble wound on 3/8-inch diameter combination iron/brass slug tuned coil form (Cambion LS-3, 10 MC coil).
- L₂. 30--70 uh coil scramble wound on same form as L₁. (Cambion LS-3, 5-MC coil).
- L₃. 1.5--3.0 uh, 18 turns, No. 24 enameled wire closewound 3/8 of an inch long on same form as L₁.
- L₄. 5.4 uh, 32 turns, No. 24 tinned wire spacewound 32 turns per inch, 1 inch long and 1/2 of an inch in diameter (air-dux No. 432) and centertapped with 2-turn link coil at center, wound with No. 20 insulated hookup wire.
- L₅. 2.8 uh, 18 turns, same coil stock as L₄, center tap.
- L₇. 2.8 uh, same as L₆ with 2-turn link at bypassed end, wound from No. 20 insulated hookup wire.

HETRODYNE VFO FOR 9-MC. SSB GENERATORS

There has been much interest in our publishing an article on constructing a hetrodyne VFO for 9-megacycle type SSB exciters, so that the proper injection frequencies for output on 1.8, 7, 21 and 28 megacycles (and even 50 megacycles) can be obtained from these exciters. Most persons now have suitable VFO's which they use to provide the proper injection frequencies (5.0 to 5.5 megacycles for operation of the exciter on the 3.9 and 14-megacycle bands.

The block diagram shows a suggested method of taking the output from a stable VFO tuning the 5.0 to 5.5-megacycle range (F_1) and feeding it into another mixer, into which a crystal oscillator signal (F_2) also is fed. The mixer output (F_3), either the sum or difference of the two input frequencies, is used as the injection frequency (F_3) into the SSB exciter. On the block diagram, all blocks above the dashed line are inside the SSB exciter. The signal designated F_4 is from the 9-megacycle SSB generator, and the F_5 signal is the desired output signal on the amateur bands.

An experimental hetrodyning unit for a stable 5-megacycle VFO has been constructed and is being tested on a Central Electronics 20A exciter. Details will be published in a future issue of G-E HAM NEWS.

Block Diagram of Hetrodyne VFO

For SSB Exciters with 9-megacycle Sideband Generator
(CENTRAL ELECTRONICS 10A, 10B and 20A,
Lakeshore and W2EWL Exciters)

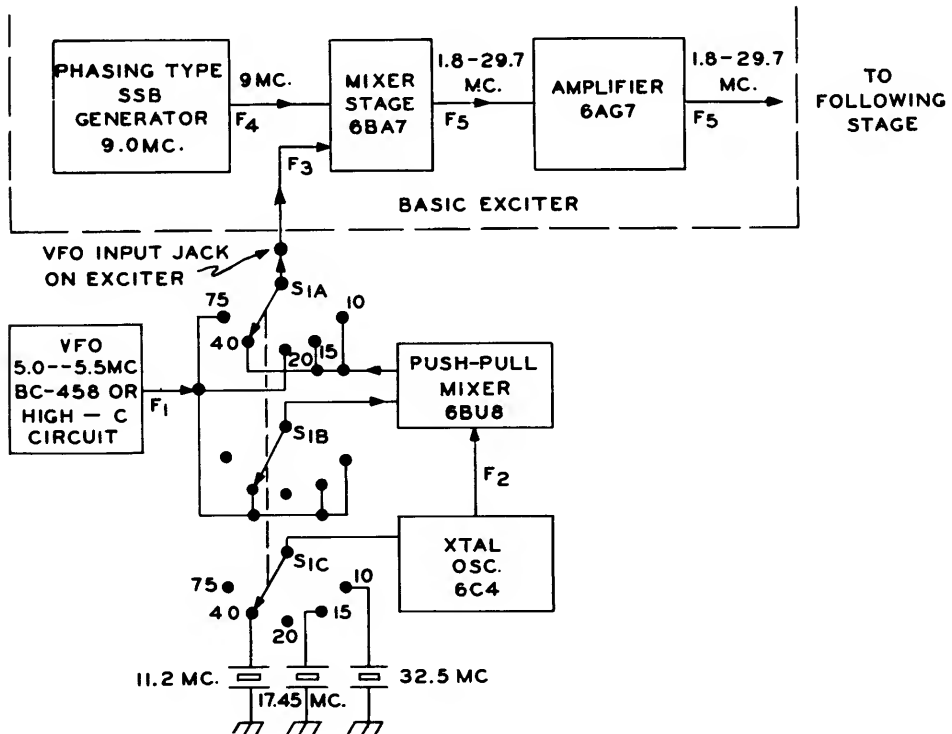

Table IV · FREQUENCY CHART

For Hetrodyne VFO for 9-megacycle Single Sideband Generators

OUTPUT BAND, MC. (F ₅)	SSB GEN. FREQ. (F ₄)	EXCITER INJECTION FREQ. MC. (F ₃)	CRYSTAL OSC. FREQ. MC. (F ₂)	TUNABLE OSC. FREQ. MC. (F ₁)
3.5 -- 4.0	9.0	5.5 -- 5.0	None	5.5 -- 5.0
7.0 -- 7.3	9.0	16.0 -- 16.3	11.0	5.0 -- 5.3
14.0 -- 14.35	9.0	5.0 -- 5.35	None	5.0 -- 5.35
21.0 -- 21.45	9.0	12.0 -- 12.45	17.0	5.45 -- 5.0
28.0 -- 28.5	9.0	37.0 -- 37.5 (19.0 -- 19.5)	32.0 (24.5)	5.0 -- 5.5 (5.5 -- 5.0)
28.5 -- 29.0	9.0	37.5 -- 38.0 (19.5 -- 20.0)	32.5 (25.0)	5.0 -- 5.5 (5.5 -- 5.0)
29.0 -- 29.5	9.0	38.0 -- 38.5 (20.0 -- 20.5)	33.0 (25.5)	5.0 -- 5.5 (5.5 -- 5.0)
29.5 -- 29.7	9.0	38.5 -- 38.7 (20.5 -- 20.7)	33.5 (26.0)	5.0 -- 5.5 (5.5 -- 5.0)

OTHER IDEAS:

The basic hetrodyne exciter circuit has several possibilities, among them:

1. A hetrodyne exciter for CW or AM operation, as shown on the previous three pages.
2. A single sideband exciter, by adding a suitable sideband generator at the crystal oscillator frequency.
3. A hetrodyne VFO unit for use with filter or phasing type single sideband generators operating on a fixed frequency outside the amateur bands (such as 9 megacycles, used in the Central Electronics 10A, 10B and 20A, Lakeshore Phasemaster, and W2EWL exciter described in QST).
4. A hetrodyne exciter for the higher frequency amateur bands, such as 21, 23 and 50 megacycles.
5. A converter unit with which to convert a single sideband signal from an exciter with output on 14 or 21 megacycles, to the 50 and 144-megacycle amateur bands, making SSB operation practical on those bands.

These projects are being investigated by the G-E radio amateurs who build equipment and write articles for G-E HAM NEWS and will be reported in future issues.

TRIODE LINEAR AMPLIFIERS

The LAZY LINEAR Amplifier was one of the most popular circuits published in G-E HAM NEWS during the 1940's, since it "arrived" just about the time that single sideband first appeared on the amateur bands. The low-cost, easy-to-drive GL-811-A zero bias triode tube made possible an efficient, reliable and practically foolproof linear amplifier design which could be driven by the 20-watt peak output SSB exciters then being used by many amateurs who pioneered this new mode of communication.

Records show that several hundred "Chinese" copies of the Lazy Linear Amplifier, and literally hundreds of additional amplifiers using the Lazy Linear circuit in different mechanical arrangements, were constructed by radio amateurs.

The original Lazy Linear Amplifier article is being repeated here. The original plug-in coil type grid and plate tank circuits are easily modified into bandswitching type circuits through the availability of modern ceramic-insulated tap switches, and ready-wound coil material.

LAZY LINEAR AMPLIFIER

Final Amplifier for AM, NBFM, CW or SSB

With Push-Pull GL-811-A Triodes

From July-August, 1949

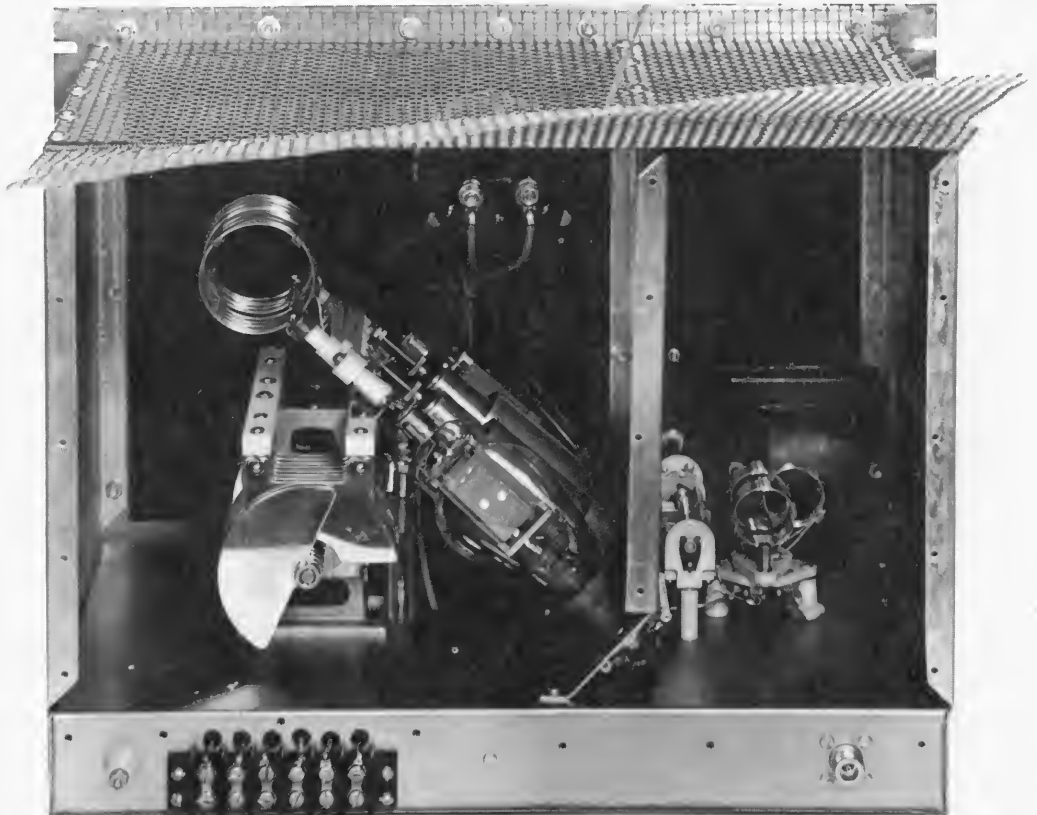

Fig. 1. Rear View of Lazy Linear with Shielding Mesh Raised to Show Detail

Why Use a Linear Amplifier?

High power linear amplifiers are very rarely used in amateur stations, although the average amateur uses linear amplifiers all the time, and may not realize it fully. All distortion-free audio amplifiers, as well as RF and IF amplifiers, in superheterodyne receivers are linear amplifiers (the limiter in an FM receiver is an exception).

Perhaps the amateur has kept away from high-power linear amplifiers because of their reputation for poor efficiency. This reputation is perhaps deserved only when AM signals are considered, as a check of Fig. 12 will show. However, a linear amplifier is ideally suited for single-sideband transmission where the peak efficiency is about 70 percent. The Lazy Linear was designed with this type of operation in mind, although data is given for operation on AM phone, NBFM phone, and CW.

The Lazy Linear is a final amplifier capable of 400 watts peak output on SSB, 400 watts peak output using a keyed carrier (CW), 180 watts peak output on NBFM phone, and 180 watts peak output (45 watts carrier power output) on AM phone. A complete comparison of these various types of emission is given in Fig. 12. In addition, the Lazy Linear has been designed to be practically TVI-proof. Complete shielding and filtering of power leads is employed in the Lazy Linear.

GENERAL LINEAR CONSIDERATIONS

linear amplifier is by definition an amplifier in which the output signal is directly proportional to the input signal. Since this is the case, the input and output signals are very much interdependent upon one another. This is emphasized because the average amateur is familiar with Class C amplifiers, and his experience with this type of amplifier will have to be forgotten temporarily when adjusting linear amplifiers. The adjustment is not difficult but the amateur must remember

that the grid current, driving power, plate current dip, etc., as applied to his experience with Class C amplifiers may mean something entirely different when working with linear amplifiers.

A linear amplifier has several very important advantages over Class C amplifiers. Because the driving power is materially lower with linear amplifiers there is far less probability of generating and radiating harmonics. This means that television interference caused by harmonics of the intended signal is much less likely. Further, the harmonic output of a linear amplifier of a given output rating is lower than is experienced with Class C amplifiers. This cuts down the amount of trouble that can be caused by harmonics and makes TVI elimination a simpler job.

For single-sideband transmission a linear amplifier is practically essential. The practical efficiency in this type of service is in the order of 70 percent on peaks. NBFM transmission could well employ a linear amplifier to take advantage of the low driving power requirements and the reduced harmonic output as compared with "Class C" amplifier operation.

In CW use, a linear amplifier opens the way to the solution of key-click elimination and bandwidth reduction. As before, of course, the driving power requirements are very low and the harmonic distortion is low. For CW work the keying and shaping may be done at a low power level point in the exciter without amplifier distortion undoing the job done at the low level point.

It is recommended that the prospective builder or user of the Lazy Linear read and digest the article "Linear R.F. Amplifiers" by S. G. Reque, which appeared in the May, 1949 QST. This article reviews the high points in the design and adjustment of linear amplifiers and will furnish good background material on the subject.

ELECTRICAL CIRCUIT

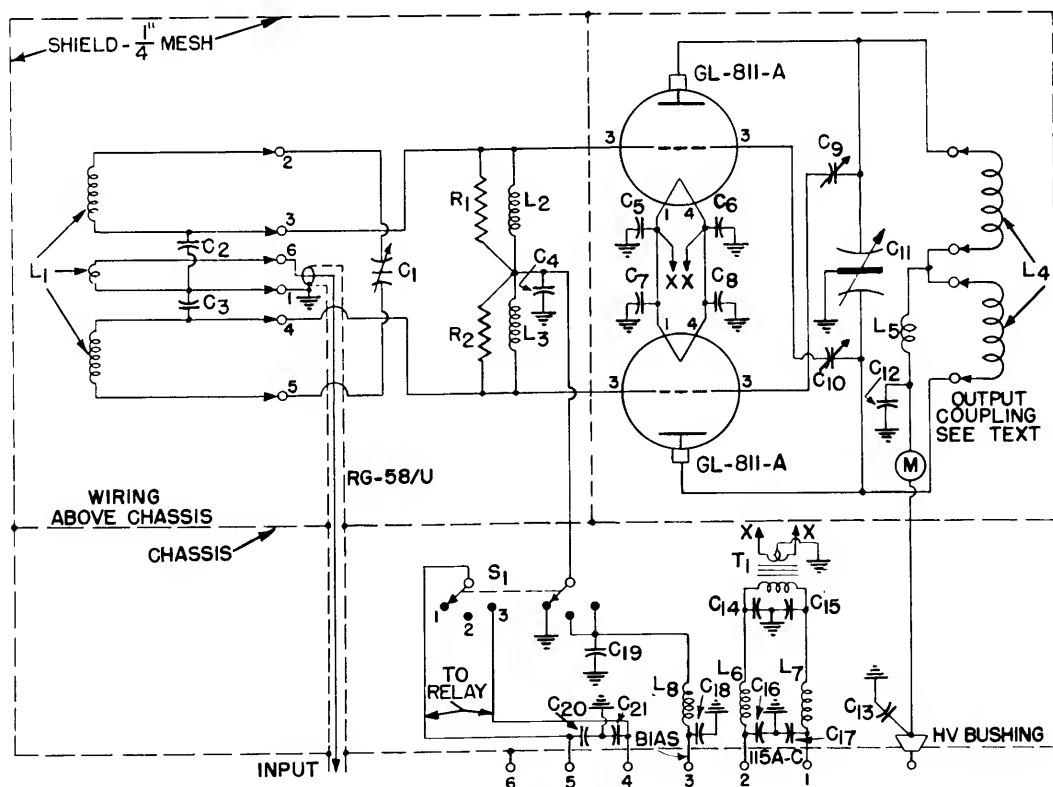

Fig. 2. Circuit Diagram of Lazy Linear

Design and Construction—Lazy Linear

ELECTRICAL DETAILS—GRID CIRCUIT

Fig. 1 will explain one reason for the name Lazy Linear. The name also applies because the tubes seem to loaf along when providing 400 watts of peak power output on SSB.

The circuit diagram for the Lazy Linear is given in Fig. 2. It will be seen that the diagram is that of the usual push-pull final with the exception of the grid circuit. In linear amplifier circuits the grid circuit is extremely important because it is necessary to provide a signal of good regulation to the tube grids. The choice of the GL-811-A tube simplifies the grid circuit design. Incidentally, the GL-811 tube will also work in the Lazy Linear, but the newer tube with its greater plate dissipation will permit a larger factor of safety in operation. The GL-811-A tubes are inexpensive and lend themselves readily to the requirements of linear amplifier operation at a power output level that is surprisingly high.

The input circuit is a combination transformer/resonant circuit/pi-matching network. Referring to the special grid circuit schematic in Fig. 3, the driving signal is coupled by means of an adjustable swinging link into a resonant circuit comprising L_{1A} , L_{1B} , C_{1A} , C_{1B} , C_2 and C_3 . If the inductance of L_{1A} and L_{1B} in series be considered as having a value of L_T , and the capacity of the four condensers C_{1A} , C_{1B} , C_2 and C_3 in series be considered as having a resultant value of C_T , resonance will be achieved when the inductive reactance of L_T equals the capacitive reactance of C_T . Further, if C_{1A} is equal to C_{1B} and C_2 equals C_3 , this relationship may be expressed in the formula:

$$C_T = \frac{C_{1A}C_2}{2(C_{1A} + C_2)}$$

Also, since C_2 will be equal to C_{1A} times a constant, K , we find that the resultant capacitance will then be expressed in the formula:

$$C_T = \frac{1}{2}K \frac{C_{1A}}{(1+K)}$$

In the design of the Lazy Linear K is equal to approximately 2.5, which calculates out to give the answer that C_2 (which is equal to C_3) equals 7 times C_T . It will be seen therefore that the choice of a coil fixes the values of the four condensers for any given frequency. Since C_{1A} and C_{1B} are variable (but equal) the ratio K will change somewhat over any given amateur band. Center-band frequencies were used in the calculations.

The foregoing information on the design of the grid circuit has been given mainly for one reason, and that is to point out the importance of the following statement. *It is absolutely necessary to use coils having the correct value of inductance in order to fulfill the combined requirements of tuning, coupling and matching in this circuit.*

The total operating Q of the circuit into which the exciter driving tube operates is approximately 20. This value of Q gives a reasonable amount of room for maladjustment without the danger of ending up with too low a Q for the driver. By the same token, the load on the grid circuit provided by the driver lowers the source impedance of the matching circuit and improves the voltage regulation of the driving system. Good grid circuit regulation is essential in order to provide the amplifier itself with a signal reasonably free from distortion.

It was found necessary to use a fixed source of grid bias in some cases. The amount of bias required (zero to -3 volts depending upon the plate voltage used) is most conveniently provided by a small 4½ volt battery. This battery should give at least "shelf life" but must be in good condition if distortion is to be held to a satisfactory point. While discussing distortion it might be well to point out that, contrary to a commonly held belief, a linear amplifier must be made as far as possible for SSB work. Amplifier distortion evidences as unwanted sideband components and cross products on either side of the carrier frequency despite the fact that the load into which the amplifier operates is a tuned load.

Resistors R_1 and R_2 and chokes L_2 and L_3 were not taken into account when making calculations on the grid circuit, but this approximation will not cause any serious error. The two resistors are loading or "swamping" resistors which serve to fix the source impedance and the operating Q of the grid circuit. Note, the rotor of C , is insulated from ground.

From the above discussion of the grid circuit of the Lazy Linear the average amateur may form the opinion that the unit is extremely complicated to build and adjust. The fact is that the design work has been carefully done so that, if the parts specified are used, the average amateur should not have any difficulties in building and using the Lazy Linear. The emphasis placed upon the design of the grid circuit has been deliberate in order to show why the circuit constants and the tune-up procedures should be followed exactly.

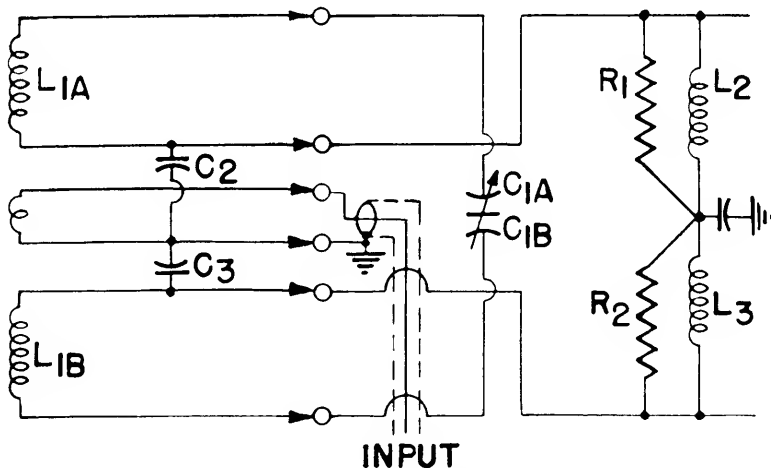

Fig. 3. Lazy Linear Grid Circuit

CIRCUIT CONSTANTS

C_1	Split-stator 140 mmf variable (Hammarlund HFD-140)
C_2, C_3	See Grid Coil Table
$C_4, C_5, C_6, C_7, C_8,$ $C_{14}, C_{15}, C_{16}, C_{17},$ C_{18}, C_{20}, C_{21}	0.005 mf ceramic or mica
C_9, C_{10}	Neutralizing condenser, 3-9 mmf, 6000 volt (Millen 15006)
C_{11}	200 mmf per section split-stator variable, 0.077 inch air-gap (Millen 14200)
C_{12}, C_{13}	0.002 mf, 2500 volt (working) mica
C_{19}	1.0 mf, 200 volt paper or oil-filled
L_1	National AR-17 swinging-link coils, modified as per text and coil table

L_2, L_3, L_8	500 microhenry r-f choke (Millen 34300-500)
L_4	Millen 44000 series "150 watt" coils, modified as per text
L_5	1.0 millihenry, 300 ma r-f choke (Millen 34107)
L_6, L_7	R-F chokes, one layer of No. 26 enamelled wire wound on new-style one watt, one megohm resistor
M	0-500 ma meter (G.E. DO-40)
R_1, R_2	1000 ohm, 10 watt non-inductive resistor (Sprague NIT)
S_1	Two-pole, three-position, non-shorting switch (Mallory 3223-J)
T_1	6.3 v, 10 ampere filament transformer (Thorndarson T-21F12 or T-19F99)

ELECTRICAL DETAILS—PLATE CIRCUIT

Push-pull operation of the GL-811-A tubes requires the use of a balanced plate tank condenser. The rotor of this condenser (C_{11}) is grounded securely to the chassis to provide a good return path to the filaments. Harmonic currents must flow through the condenser back to the filaments, and they need all the encouragement, that is, low impedance, that can be provided.

The remainder of the circuit is quite usual. Note that the high voltage required should be un-modulated d-c. No attempt should be made to employ high-level plate modulation.

No output coupling arrangement will be seen in Fig. 1. This does not mean that the Lazy Linear has not been tested on the air. As a matter of fact, the Lazy Linear was thoroughly tested on the air and some of you reading this may have had a QSO with W2KUJ while the unit was undergoing tests at his shack.

Output coupling may be by means of an adjustable link arranged to swing between the two halves of the plate tank coil. Or, a balanced pi-matching network with grounded neutral may be used. In any case, provision for adjustment of the coupling (or at least the reflected load) must be made. Ample space is available for mounting a swinging link on the chassis next to the tuning condenser. If a pi-network is used this should be connected to the stator plates of the tuning condenser by means of blocking condensers of ample voltage rating (0.001 mf at 2500 volts working should be suitable).

Approximately 8000 ohms plate-to-plate loading is correct, although the exact value depends upon the plate voltage used and the class of service employed. As was true in the grid circuit, coils of the proper value of inductance are necessary in order to preserve suitable L-C ratios on each band. Plate coil specifications are as follows: The Millen 44000 series coils are used. For example, 44010 is the 10 meter coil, 44020 is the 20 meter coil, etc. These coils are used without change with the following exceptions. Coil 44080 is used for 160 meters and extra padding capacitance is required in parallel with C_{11} . Two 200 mmf condensers should be used, one in parallel with each stator section of C_{11} . These capacitors may be fixed air condensers or vacuum condensers, or even a variable condenser from the junk-box set at the proper capacitance.

Coils 44010, 44020 and 44040 will work without alteration on 10, 20 and 40 meters. Coil 44080 must be altered by removing 6 turns from each half of the coil. (This means that two 44080 coils are required, one for 80 and one for 160.)

For those who desire to make their own coils, the desired inductance for the 160—10 meter coils, respectively, is 40, 20, 10, 5 and 2 microhenrys.

MECHANICAL DETAILS

The Lazy Linear is constructed on a 11 by 17 by 2 inch plated chassis and uses a 19 by 14 inch front panel. The entire unit must be shielded to minimize TVI. Figs. 4, 10, and 11 show the constructional details of the metal pieces which act to support the shielding mesh and also to shield the input circuit from the plate circuit. Two pieces of galvanized quarter-inch mesh hardware cloth are cut to size to provide the top shield and the rear shield. They are bent cut to size when the other metal pieces are mounted in position and properly aligned. In addition to all this shielding, a cover plate is used on the bottom of the chassis.

To make the shielding effective, remove the paint around the edges of the rear side of the front panel so that good electrical contact can be made between the front panel and the end plates, between the front panel and the quarter-inch mesh, between the front panel and the chassis, and between the front panel and the rack on which it mounts. The paint must also be removed from around the meter hole, on the rear face of the panel, so that the copper screen which covers the meter hole may be soldered to the panel. The meter itself is mounted on standoff posts to prevent breakdown between the meter and the panel. If the meter case is metal, insulated standoff posts must be used.

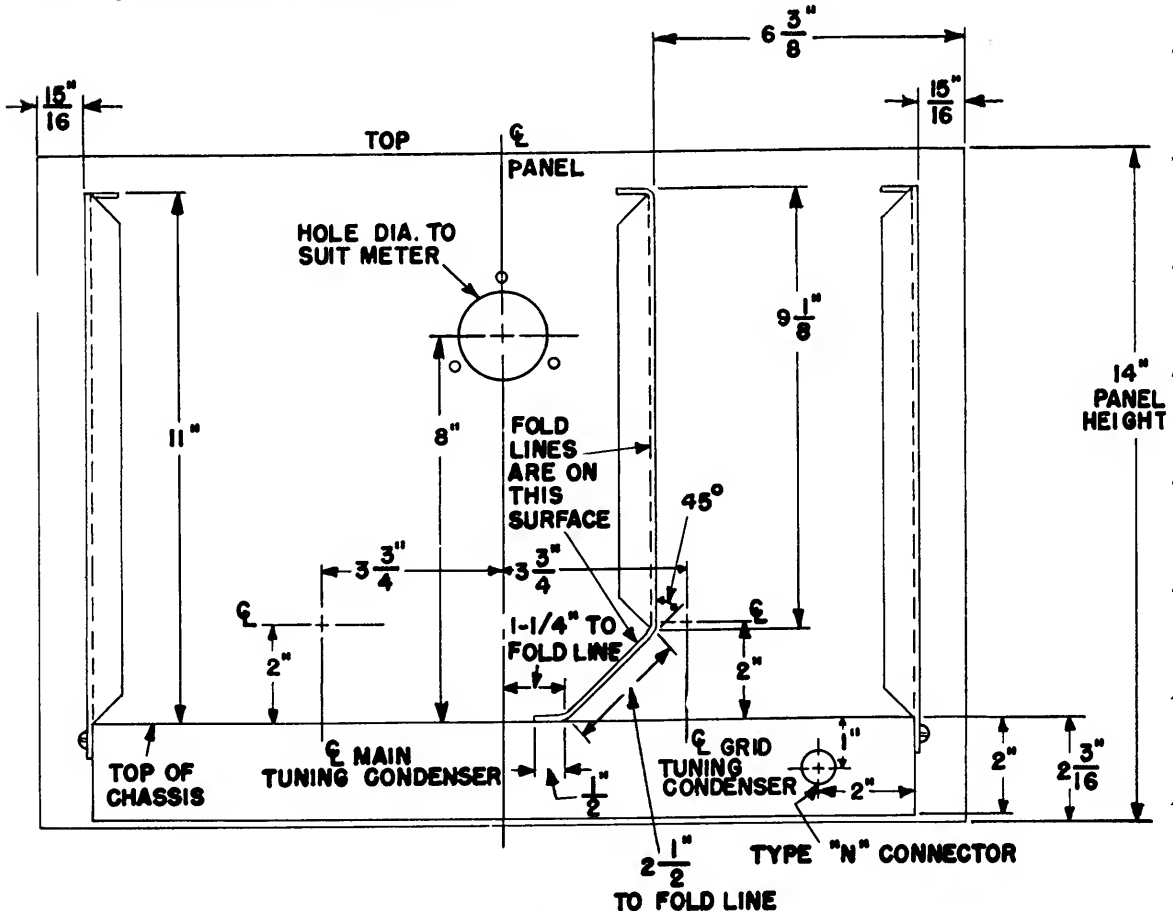

Fig. 4. Detail of Chassis and Panel Assembly (Rear View)

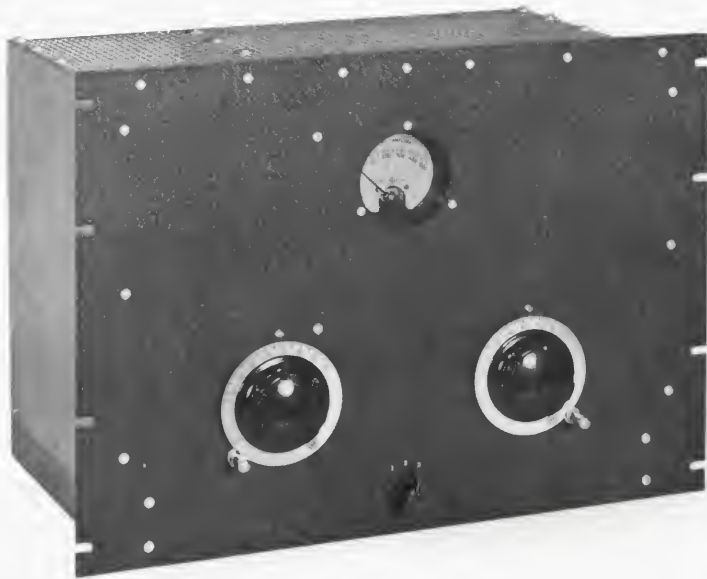

Fig. 5. Front Panel View of Lazy Linear

The rear shield of quarter-inch mesh is hinged to the top quarter-inch mesh by means of a length of flat half-inch wide copper braid. The braid should be soldered to the galvanized mesh at every point along the joint.

Detail photographs are given of the grid section and the plate section. The plate section detail, Fig. 8, shows how the Millen coil base is mounted on the Millen condenser. Two pieces of 1/16 inch brass, one inch by one inch, must be made. A half-way point fold is placed in these pieces at a 45 degree angle. When the 6-32 screw is removed from the tuning condenser in order to mount the brass plate it will be seen that the threaded area is too small to allow re-use of the same machine screw. A longer screw must be provided. However, take care that it is not too long, as it may strike the threaded rod on which the stator plates are mounted. It may be necessary to file the machine screw used to the proper length.

It will also be necessary to cut off approximately one inch of the stud which forms the top part of the neutralizing condenser so that it will fit in the space provided.

By following the photographs and the sketches, no difficulty should be encountered in the construction of the Lazy Linear. Make sure that you do a good job on the bypassing, especially where the power leads enter the rear of the chassis. Use as short leads as possible.

The dials shown in the front-panel view, Fig. 5, are Millen 10008 with Millen 10050 dial locks.

Grid coils required are the National AR-17 swinging link series. Because the input circuit is a pi network changes must be made on each of these coils. As received the coils have a center-tapped link and only one connection from the center point of the two main coils. Further, it is necessary to add C_2 and C_3 on each coil, and in the case of the 160 and 80 meter coil additional padding must be added so that it is effectively in parallel with C_1 .

The changes should be made as follows: Cut the wire which connects pin 3 to the center-tap of the link about $\frac{1}{4}$ of an inch below where it connects to the link. The two main coils are joined by a wire which is molded into the center piece of

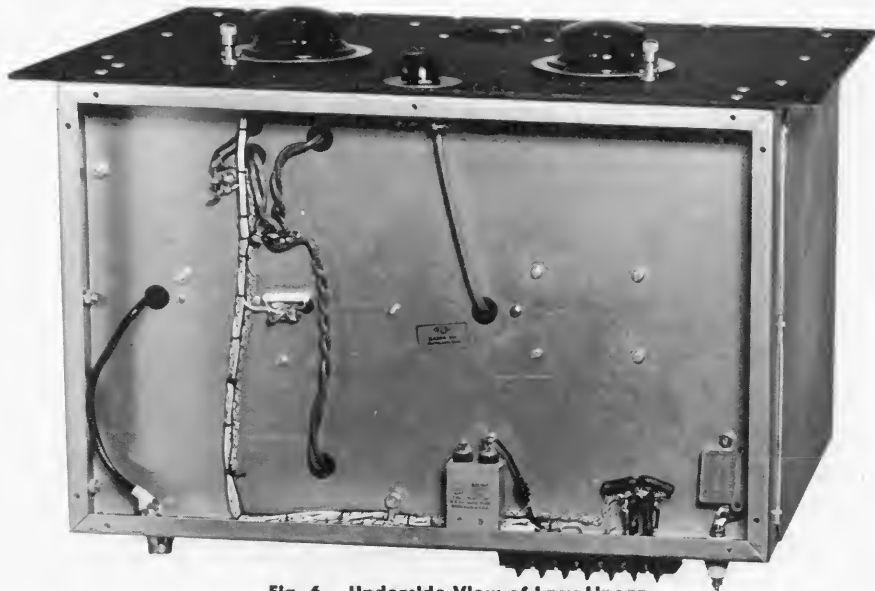

Fig. 6. Underside View of Lazy Linear

insulating material. Find the point on this wire where the connection to pin number 4 is made and cut the joining wire just below this point. The wire just cut now connects to the wire going to pin number 3. Add condensers C_3 and C_4 , and the padding condenser if required, and the job is done. It will be necessary to match C_3 and C_4 within 5 percent in all cases. Repeat for all grid coils. (See Grid Coil Table for proper values to add.)

GRID COIL TABLE

160 meters: (No National AR-17 series coil was available at time of writing.) A suitable coil can be made as follows:

Each half to be 50 turns, 1 inch in diameter, 32 TPI spacing. (B & W Miniductor No. 3016 cut in half.) Space two halves one-half inch apart. Make link also 32 TPI, 1 inch in diameter, 12 turns. Pad (pin 2 to 5) with 100 mmf. C_3 equals C_4 equals 1000 mmf.

80 meters: Use National AR-17-80S. C_3 equals C_4 equals 470 mmf. Use a 20 mmf mica padding condenser from pin 2 to pin 5.

40 meters: Use National AR-17-80S and remove 8 turns from each coil half. C_3 equals C_4 equals 250 mmf. Remove 5 turns from link.

20 meters: Use National AR-17-40S. C_3 equals C_4 equals 100 mmf.

10 meters: Use National AR-17-20S. C_3 equals C_4 equals 50 mmf.

Desired inductance, for those who wish to make their own, for the 160—10 meter coils, is, respectively, 65, 32, 16, 9 and 3 microhenrys.

EXCITER REQUIREMENTS

The table of Fig. 12 indicates various modes of operation and gives information on driving power, plate operating conditions, etc. In general the driving power requirements are very low. Any exciter which ends up in an 807 or a tube of similar power should be suitable to drive the Lazy Linear for any mode of operation, provided that the exciter itself provides the proper type of emission. The exciter described by W2KUJ in the March and April 1949 CQ will provide an adequate driving signal for all types of emission (SSB, AM, NBFM).

POWER SUPPLY REQUIREMENTS

The rating table, Fig. 12, gives plate current requirements for various modes of operation, where the type of emission allows this information to be given. The voltage required will depend upon the builder's personal choice of the types of operation desired. If only AM and NBFM operation is contemplated, the power supply may be of conventional design.

For CW and SSB operation the heavy bleeder normally used to achieve good regulation may be replaced by a high resistance bleeder which will serve to discharge the filter condensers. The stand-by current drain taken by the Lazy Linear takes the place of the heavy bleeder current. Because of the intermittent current drain which typifies CW and SSB speech transmission, special care must be taken in the power supply design to avoid power supply filter resonance. A practical means of achieving this is to use a 10 to 20 mf output condenser.

TUNE-UP ADJUSTMENTS

Before attempting to get the transmitter operating properly, re-read Reque's article on linear amplifiers, as the two-tone test described therein will not be described here.

Select your band and insert the proper coils. Couple an exciter to the grid so that an un-modulated signal drives the Lazy Linear. Tune for maximum grid current (measured by an external meter in the bias supply when switch S_1 is in position 2 or 3). The filaments must be on, and the plate supply disconnected from the rear high-voltage bushing. Any grid current from 50 to 100 mils will be satisfactory now.

Neutralize the final in the usual manner. Make sure the plate tank condenser is tuned to resonance during the neutralizing process. If opportune, neutralize on the highest frequency band you intend to use.

The next step is to match the grid and plate circuits. Couple the final to a dummy load. Arrange an oscilloscope with the vertical connections connected across the dummy load so that the plate output may be observed. Apply a small input signal to the grid circuit, making sure that the grid link is loosely coupled. Now apply plate voltage (not over 1000 volts) and resonate the plate tank for maximum output as shown by the scope. The plate current should be approximately 50 to 100 mils, depending on the excitation. This may be reached by 1) making a crude adjustment of the plate loading with the dummy load, or 2) detuning the plate tank slightly to get the desired plate current. Strive for approximately 75 mils.

Under these conditions you should now match the exciter to the grid circuit. The objective here is to present the right load to the exciter so that the exciter works properly. In other words, you are familiar with the operation of your exciter, its plate current when running properly, etc. Adjust the coupling between the exciter and the grid circuit, by means of the link, (while adjusting C_1) until the exciter is working as it should. If the exciter you chose supplies sufficient power output, then there should be sufficient drive to the Lazy Linear. (See the table in Fig. 12 for approximate driving powers required.) While making these coupling adjustments by adjusting the link, work from a lightly loaded condition toward heavier loading, making sure that the grid condenser is in tune at all

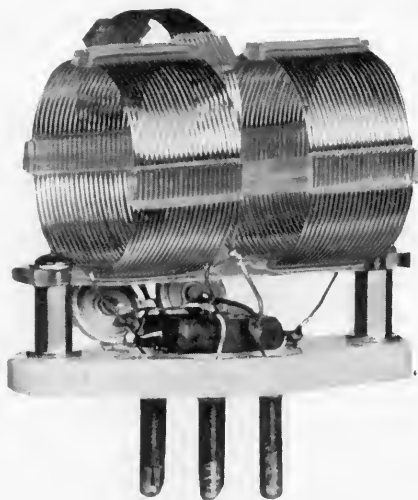

Fig. 7. Detail of Grid Coil

COIL TABLE FOR CONSTRUCTING GRID TANK CIRCUIT COILS FOR LAZY LINEAR AMPLIFIER

The following coils may be substituted for the National AR-17 series originally used in this circuit. The same padding and network capacitors, given in the grid coil table on Page 4 of the Volume 4, No. 4 issue of G-E HAM NEWS, must be used.

3.9 Mc. - Original coil was National AR-17-80S. Homemade coil - 32 uh total - make two 22 turn coils of B & W No. 3016 miniductor spaced 1/2". Link 1.7 uh, 8 turns of same material inserted in space.

7 Mc. - Original coil was National AR17-80S with 8 turns removed from each end. Homemade coil - 16 uh total - use No. 3015 miniductor - cut 2 coils each 19 turns and space 1/2 inches - link 1.7 uh - 6 turns same material in space.

14 Mc. - Original coil was National AR-17-40S. Homemade coil - 9 uh total, make 2 coils each 11 turns each of B & W No. 3015 miniductor and space 1/2". Link 0.92 uh, use 6 turns same material inserted in space.

21 and 28 Mc. - Original coil was National AR-17-20S. Homemade coil-3 uh, make 2 8-turn coils of No. 3014 miniductor with 3/4" spacing. Link 0.92 uh, use 5 turns of same material or 4 turns No. 3015.

ASSEMBLY AND BASE:

Allow 1 extra turn at each end of each coil section to form leads for connections to plug-in base. Connect as shown in circuit diagram, Fig. 2, on Page 2 of Volume 4, No. 4 issue. Make plug-in base from amphenol 86-CP6T Mica - Bakelite male 6 pin connector assembled with plate and retaining ring from amphenol 78-RS6 replacement socket. Coils mounted on 1/4 x 1/2-inch piece of polystyrene or lucite 3 inches long with 3/4-inch long spacers on fastening screws. Coils cemented to strip with low-loss coil cement.

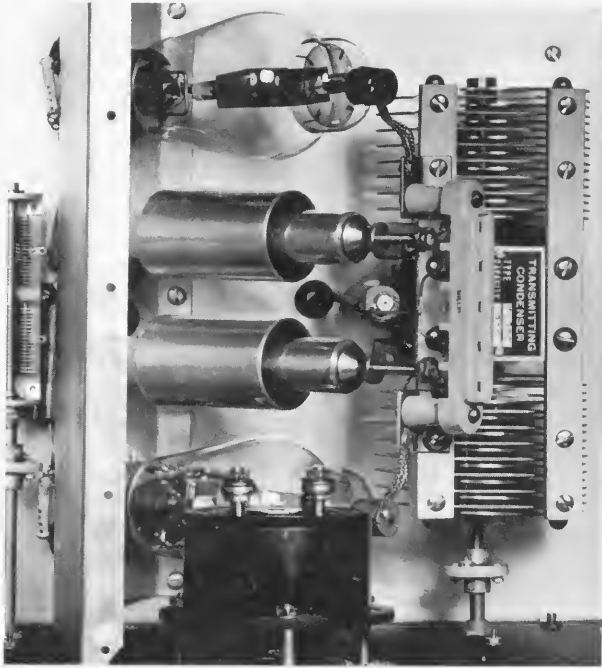

Fig. 8. Detail of Lazy Linear Plate Circuit

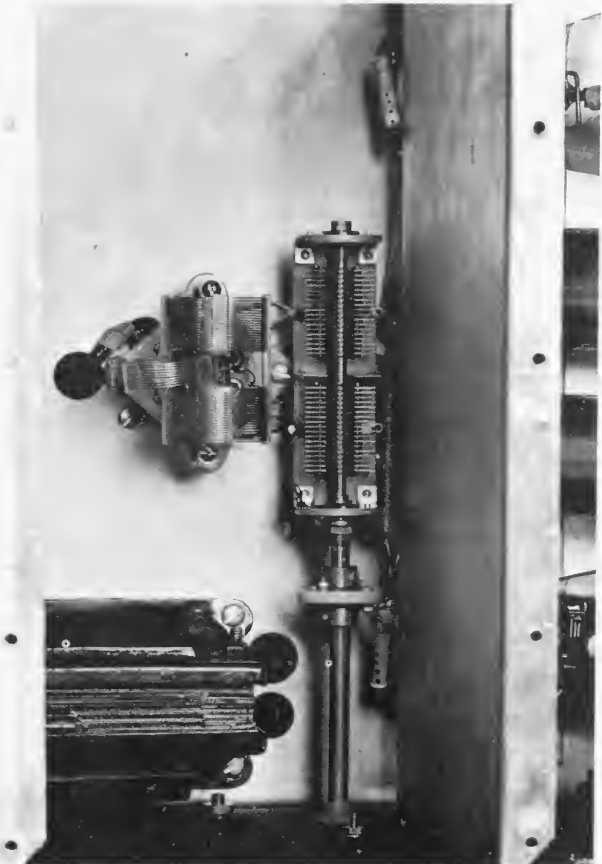

Fig. 9. Detail of Lazy Linear Grid Circuit

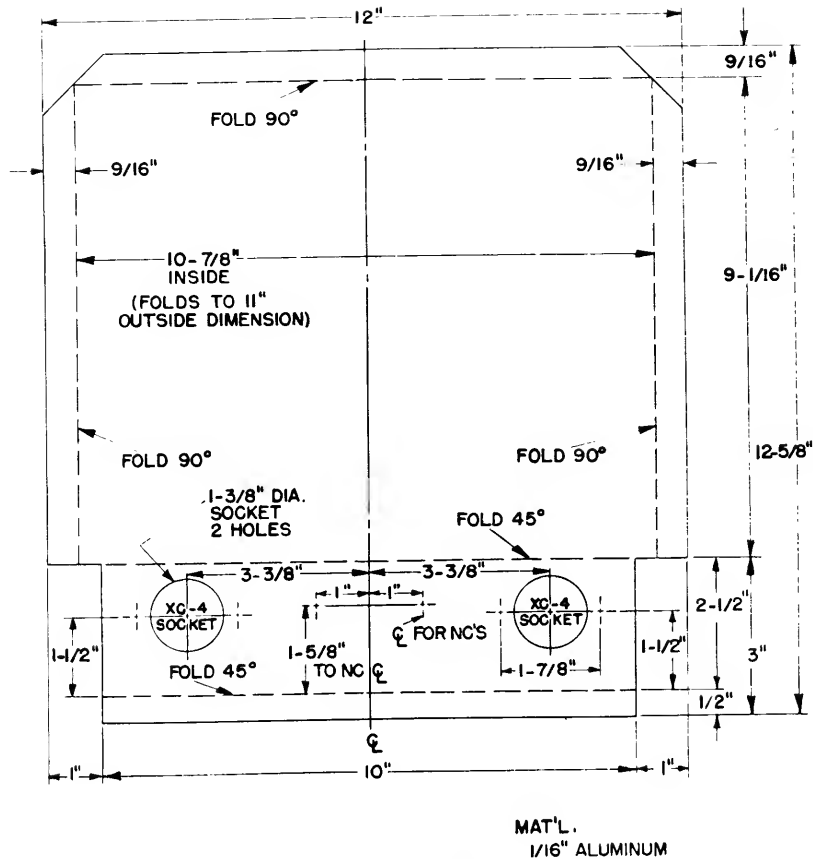

Fig. 10. Detail of Interstage Shield

times. The grid current will be significantly lower with plate voltage applied than it is with plate voltage off, so do not become concerned about the apparent loss of grid drive. An oscilloscope lightly coupled to the grid circuit can be a valuable adjustment aid.

No figure can be put on the grid current to be expected, as it may vary by a factor of perhaps five to one, depending on the plate loading, which has not yet been adjusted. However, do not exceed the maximum grid current rating of 100 ma for two tubes.

The amplifier has now been adjusted in a preliminary sort of way, and we are ready to proceed with the two-tone test as described in Reque's article, which has been referred to before. Apply a two-tone test signal to the grid circuit of the Lazy Linear. No more than 1000 volts d-c should be applied to the Lazy Linear plate circuit at this time. The envelope observed on the scope should now be as indicated in Fig. 4 of Reque's article, at least for low level inputs driving the final.

Now, with the plate load lightly coupled and C_{11} at resonance increase the input signal until the envelope flattens on peaks. The scope should be coupled to the output circuit for this test. (Note that this is *not* the distortion shown in Fig. 5 of Reque's article.) The envelope flattening may be caused by one or both of the following two conditions. 1) The driver may be improperly coupled or loaded, or it may be at the limit of its output capability, or, 2) the loading on the plate circuit may be too light, which means that the reflected load impedance is too high.

To check for point 1, couple the oscilloscope to the grid circuit of the Lazy Linear. If the envelope shows an undistorted signal (Fig. 4, Reque's article) then point 2 is causing the trouble. However, if the peaks are flattened, then the driver is supplying a distorted signal.

To check for point 2, couple the scope to the dummy load again, and watch the distorted pattern as the final tank condenser is detuned toward a higher capacity. If the plate current goes up more than 20 percent and the flattening effect seems to disappear, then the load should be coupled more tightly to the final. If this is the case, retune to resonance, couple tighter, and again check the pattern on the scope. Take care not to overload the tubes during this adjustment. Any

more than a very slight indication of color in the tube anodes should be avoided.

At 1000 volts plate supply and with the two-tone signal to the grid circuit, the plate current will be in the order of 160 ma, although this value is governed by the signal strength coming from the driving stage. Optimum plate loading is that which causes a flattening of the peaks of the scope pattern as the drive is slightly increased (assuming that the driver itself is not limiting). Very little dip in plate current will be noted when tuning through resonance with the plate condenser when the amplifier is properly loaded.

With conditions as just previously described, that is, 1000 volts on the plate, two-tone test signal coming in, the average power input to the final will be 160 watts, and the peak input 1.57 times this figure or 250 watts, and the peak output will be approximately 175 watts, with a realizable 70 percent overall plate efficiency.

With the loading adjustment unchanged, the plate voltage may be increased to 1500 volts, and the bias changed to minus 3.0 volts. This is the reason that switch S_1 was incorporated in the Lazy Linear. In position 1 the grid bias is zero and the external plate voltage relay is not energized. In position 2 external bias is switched into the circuit and the plate voltage stays the same. In position 3 the external bias is unchanged but a relay may be actuated to change the voltage from 1000 to some higher voltage.

When operating with 1500 volts on the Lazy Linear several precautions must be observed. First, the two-tone test signal will cause over-heating of the final tubes if applied for more than 5 seconds at a time. Also, the 1500 volt condition can be used only when the final is driven by an exciter which puts out a single-sideband speech signal, or driven by a keyed exciter.

When testing at 1500 volts, apply a SSB signal from the exciter and talk into the mike (use no prolonged whistle or other steady tones). Increase the drive until the voice f reach a definite saturation point as seen by the scope connection across the output. Assuming that the driver itself is not limiting, then this point represents the maximum peak output signal consistent with the loading and plate supply voltage used. It will be approximately 400 watts peak output. The loading of the output circuit will be the same as used with the 1000 volt tests.

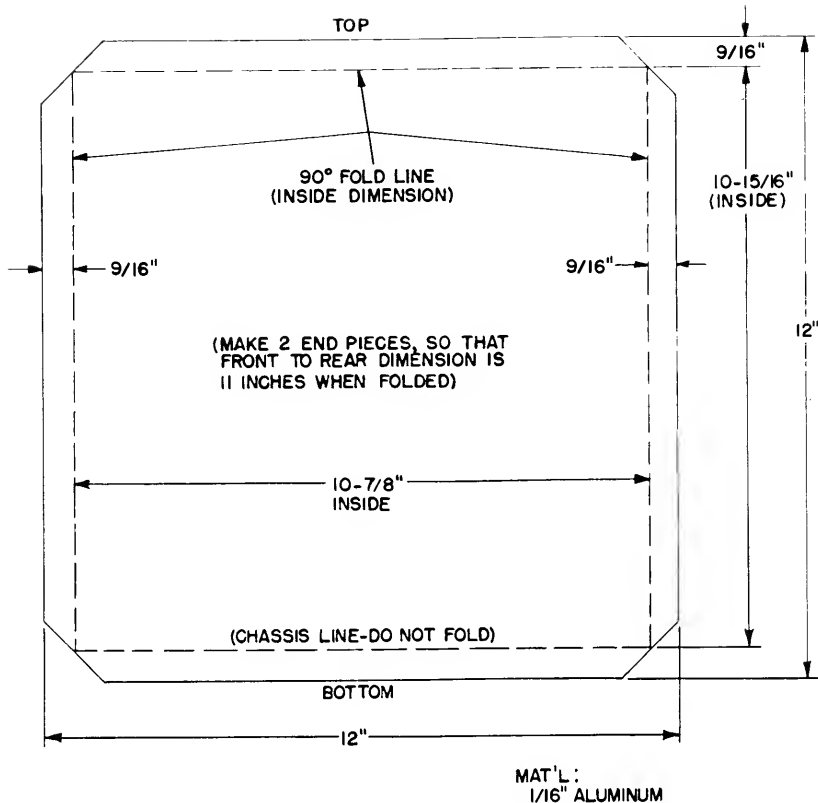

Fig. 11. Detail of Side Shields

Never attempt to operate the final beyond the saturation point just discussed. If desired, distortion may be checked by means of the two-tone test signal, when using 1500 volts, if the signal is left on for only a second or two (long enough for the plate current meter to settle down so that it may be read.) When making this test, the bias should be minus 3.0 volts and the average plate current as seen on the meter will be 240 ma, approximately. Make this test only after the tuning procedure and performance has been thoroughly checked at lower volt-

ages. Even then, do not leave the two-tone test on for more than a second or two. This is important if you wish to use the very same tubes in the future!

After one is satisfied with the tune-up procedure, then the dummy antenna may be replaced with the radiating antenna and the coupling checked, at 1000 volts, with the two-tone test signal for a quick on-the-air test. Always monitor the output signal with an oscilloscope when you are on the air. This is the most reliable method for monitoring a phone signal.

#	EMISS-ION TYPE	INPUT SIGNAL REQ'D	PLATE VOLT-AGE	PLATE CURRENT MA.	PLATE INPUT W.	CARR. OUT. W.	PEAK OUT. W.	NOTES
1	AM	100 % MOD. 2 WATTS	1000	CONSTANT 150	CONSTANT 150	45	180	A. PLATE TO PLATE IMPED. FOR ALL CONDITIONS IS 8000 OHMS. DETERMINE LOADING AT ONE KV. WITH TWO TONE TEST OR EQUIV. IS ZERO. B. CONDITIONS 1, 2, 3 AND 5 BIAS IS ZERO. C. CONDITION 4 BIAS - 3 V. D. CONDITION 6 BIAS - 3 V. E. RECOMMENDED CONDITION WHERE AM, NBFM, CW AND SSB USED INTERCHANGEABLY. F. CONDITION 4 FOR KEYED SIGNALS ONLY. G. CONDITIONS 6 FOR SPEECH ONLY.
2	NBFM	NBFM 8 WATTS	1000	CONSTANT 250	CONSTANT 250	175	180	
3	CW	CW 8 WATTS	1000	KEYDOWN 250	KEYDOWN 250	175	180	
4	CW	KEYED CARRIER ONLY-20 W.	1500	380	570 SEE NOTE F	400	400	
5	SSB	SSB 8 W. PEAK	1000	VARIABLE BUT STATIC PLATE CURRENT WILL BE 35 APPROX.	VARIABLE	SEE NOTE E	180	
6	SSB	SSB 20 W. PEAK	1500			SEE NOTE G	400	

Fig. 12. Performance Table for Lazy Linear

POWER PEAKER LINEAR AMPLIFIER

A 200-Watt Output Linear Amplifier

For Single Sideband Operation

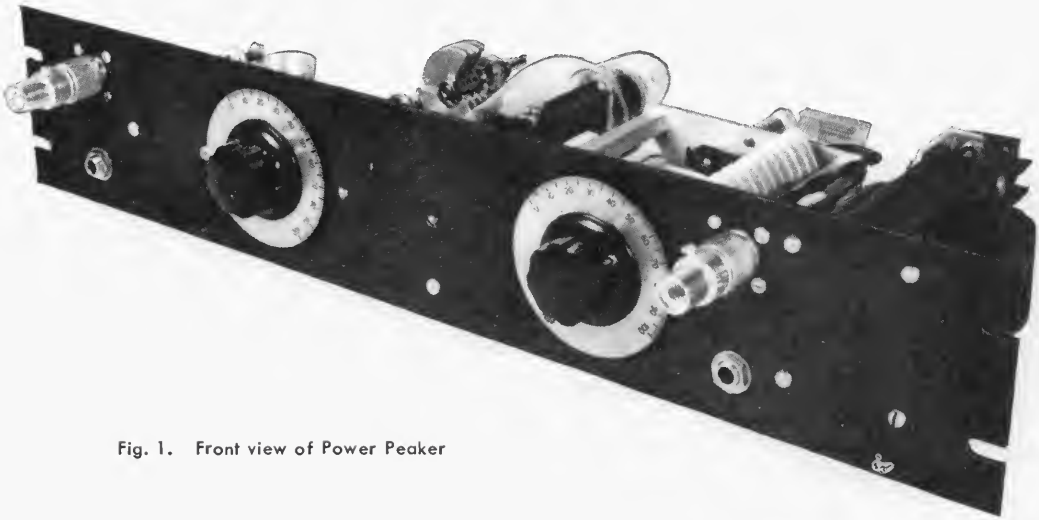

Fig. 1. Front view of Power Peaker

The Power Peaker is a complete single-tube linear amplifier featuring compact design for relay rack mounting. The r.f. driving power, for full 200-watt peak output, is less than 5 watts on any band from 80 meters to 10 meters. Thus, use of the Power Peaker driven by a single-sideband exciter, such as the SSB, JR (G-E HAM NEWS, VOL. 5 NO. 6), allows the single-sideband enthusiast to increase power by approximately 20 db. Two hundred watts of single-sideband is more than the communication equivalent of a half-kilowatt (plate input), high-level modulated AM rig operating at 80% efficiency. The Power Peaker will serve as an effective link between the 5-watt exciter and the antenna or a super-power (about 5 KW) final.

GENERAL DESCRIPTION

The Power Peaker amplifier is entirely self-contained (except for plate power supply) on a $3\frac{1}{2}$ x 19 inch relay rack panel. All parts mount directly from the panel so that construction is easy and straightforward. The power amplifier tube is the rugged and dependable GL-811-A mounted horizontally near the center of the panel. Coaxial fittings are used for the r.f. input and output connections. Input and output tuning controls are accessible on the front

panel as well as grid and cathode current jacks for circuit metering and tune-up. A filament transformer (T1) is mounted on the back of the panel to simplify the metering circuits and to avoid voltage drop in long filament leads.

Easily accessible plug-in coils are used for grid and plate circuits. Coupling adjustments may be made readily to match both input and output. These adjustments, once made for each band, "go with the coils" and need not be done again when changing bands. The neutralizing adjustment remains fixed from one band to another.

CIRCUIT DESIGN DETAILS

The circuit diagram of a linear amplifier is almost the same as that of a class "C" amplifier. Close inspection, however, will reveal an important difference between the Power Peaker and the conventional class "C" amplifier, that of bias. The GL-811-A is operated at zero bias and this feature makes additional swamping unnecessary. Actually this linear amplifier is self-swamped. Operating at zero bias reduces the driving power required, stabilizes the input impedance to reduce amplifier distortion, and, of course, eliminates the need for a bias supply.

The grid circuit is used as a phase inverter (accomplished with a split-stator tuning condenser) to per-

mit grid-circuit neutralization. This arrangement reduces complexity and cost in the output circuit since it allows a single-unit plate tuning condenser to be used. The center tap of the grid coil is brought out to a grid-current jack (closed circuit type) through a 2.5 millihenry r.f. choke. The operating Q of the grid circuit is approximately 25.

The plate circuit is shunt-fed, thus reducing the insulation requirements on both the output tank coil and tuning condenser. Shock hazard is also reduced by this method. Economy of the design of the Power Peaker is exemplified by the use of small exciter-size plate tank coils. Although the amplifier will deliver a peak power output of 200 watts when loaded and driven properly, the small-size coils do not overheat. This, of course, is true because the average power of speech is small compared to peak power. The operating Q of the plate tank circuit is approximately 12 when the amplifier is loaded properly.

The over-all electrical design of the Power Peaker is aimed at economy, high efficiency (70% on peaks) and low distortion. Complete fulfillment of these design aims will not obtain, unless the coils and tuning condensers have respective inductances and capacities that are compatible with the original design. Because of the wide tuning range available, it is not sufficient just to use coils that will resonate at the desired frequency—they must resonate with the correct capacity for the frequency band in use.

It is strongly recommended that the Power Peaker be used **ONLY** with single-sideband suppressed carrier signals. The rating given is for this mode of operation only. More than momentary testing with continuous signals is almost certain to damage several of the components due to overheating. Keep this in mind.

CONSTRUCTIONAL DETAILS

The Power Peaker linear amplifier uses standard components throughout except for modification of the coils. This is necessary to obtain the required L/C ratios. Fig. 4 gives the layout of the 3½ x 19 inch (steel or aluminum) panel. Remember to reserve a clear space of at least one inch at each end of the panel for mounting on the rack. The plate tank condenser, C7, is spaced ½ inch from the panel by the three spacers furnished with the Hammarlund TC-220K condenser. Before mounting this component, scrape the paint from the rear of the panel under the spacers to assure good electrical connection. The socket for the plate tank coil, L4, is mounted on the end of the plate condenser, C7, with ¼-inch spacers, and oriented so that the axis of the coil is as shown in Fig. 3. The coil socket pins 1 and 6 should be toward the top of the panel. Ground pin 6 and use pin 1 for the adjustable tap connection. It will be necessary to drill and tap the back of the plate tank condenser in order to mount the coil socket. Be certain to use fiber washers next to the ceramic socket to prevent cracking as it is tightened.

The grid tuning condenser, C1, is mounted on the rear of the front panel after the paint is removed from the area immediately around the mounting hole. In general, be certain to do this for all grounded components. The National STN neutralizing condenser, C2, is mounted on a metal bracket ½ inch by 1⅝ inch long fastened to the rear of the grid tuning condenser, C1. The rear shaft bracket of the Hammarlund MCD-100M condenser already has two tapped holes (No. 4-40 thread) which can be used to mount the bracket. The stator plate of the STN condenser must be insulated from this bracket by means of the two stand-off insulators supplied with the condenser.

Electrical Circuit

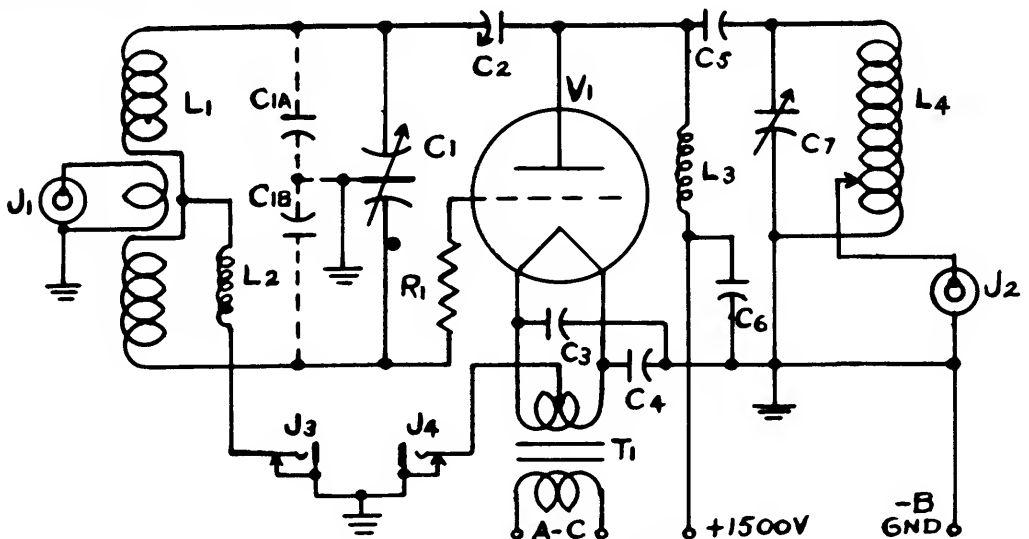

Fig. 2. Circuit diagram of Power Peaker

The tube socket should be spaced from the panel by two $\frac{3}{4}$ -inch metal or ceramic spacers. The plane of pins 1 and 4 (filament pins) must be vertical as the panel is to be mounted. This is necessary to protect the tube from damage due to filament sag. The two 0.01 mfd ceramic disc filament by-pass condensers are mounted between the socket and the panel using shortest possible connections to a lug securely grounded. The plate supply by-pass condenser, C6, stands alongside the socket and one end is grounded to a lug fastened under the other socket spacer. The B plus end of the condenser is soldered to a lug mounted on a ceramic stand-off insulator. This point also serves to support the cold end of the National R-100, 2.5 millihenry shunt-feed r.f. choke. The plate blocking condenser, C5, is mounted between the stator lug of the plate tank condenser, C7, and the hot end of the shunt-feed choke, L3. A solid wire connects from this last-named point to the stator of the STN neutralizing condenser, C2. The objective here is to provide a rigid mounting for the blocking condenser, C5, and the top of the plate choke, L3, and to provide a connection point for the short insulated stranded-wire plate lead. The top of the blocking condenser, C5, should be below (toward the panel) the plane of the bottom of the plate of the tube to prevent interception of large amounts of heat radiated from the tube. A straight-across mounting of the blocking condenser should be about right, with due allowance made for inserting the GL-811-A. Fig. 3 shows these details clearly. A solid wire connection should be made from the same lug that mounts one end of the blocking condenser to the hot pin of the plate coil socket mounted on the end-plate of the tuning condenser. Use No. 14 AWG (or larger) for these solid-wire leads.

The filament transformer, T1, is mounted $\frac{1}{2}$ inch from the panel on metal spacers to clear the leads which come out the bottom of the transformer. If the transformer you use does not have the leads coming out this way, it may be mounted flat against the panel. A terminal board is fastened to the top of the transformer by means of two right-angle metal brackets.

This terminal board serves to connect the a-c supply and the 1500-volt d-c plate supply to the amplifier. A barrier-type terminal board is recommended for the sake of safety and to prevent inadvertent short circuits.

The center tap of the 6.3-volt winding of transformer T1 should be connected to the tip spring terminal of the closed-circuit cathode current jack, J4. Be certain to ground this jack securely to the metal panel. There is space on the panel below the transformer for a primary filament switch, if separate control of the filament is desired.

The ceramic socket, for the grid coil L1, is mounted on stand-off insulators so that the axis of the coil is vertical as shown in Fig. 3. The socket pins used for the swinging link should be toward the end of the panel for convenience in wiring and adjustment of the swinging link. The end connections (pins 2 and 5) of the grid tank coil should be connected with solid wire to the two stator sections of C1. The stator section away from the panel should be connected to the rotor of the STN neutralizing condenser. The stator section nearest the panel should connect to the grid pin of the GL-811-A socket (pin 3) through a 10-ohm, 1-watt non-inductive resistor (R1). This resistor is mounted by its pigtail leads between the stator connection and the socket terminal. The center tap of the grid coil (socket pin 4) should connect through a National R-100, 2.5 millihenry r.f. choke, (L2), to the tip connection of the closed-circuit grid current meter jack, J3. This choke may be supported by its pigtail leads from the socket connection and the jack terminal. Ground pin 3 of the grid coil socket to the panel with as short a lead as possible.

The filament wires may be twisted together and run between the plate condenser and the panel from the transformer to pins 1 and 4 of the GL-811-A socket. The B plus lead should run from the terminal board to the ceramic post supporting the shunt-feed r.f. choke. This lead should be kept clear of the stator connection of the plate tank condenser. Be certain to use wire with adequate insulation to withstand the 1500 volts.

CIRCUIT CONSTANTS

(All resistors and capacitors $\pm 20\%$ unless specified otherwise)

C1.....	100-100 mmf variable condenser, Hammarlund MCD 100-M	L1, L4....	National AR-17 coil, modified. See coil table
C1 _A , C1 _B ...	See coil table	L2, L3....	2.5 mh r.f. choke, National R-100
C2.....	3-18 mmf neutralizing condenser, National STN	R1.....	10 ohm carbon, 1 watt resistor
C3, C4....	0.01 mfd disk type ceramic condensers	T1.....	6.3 volt, 4 amp., ct, Stancor P4019 or equivalent
C5, C6....	0.001 mfd, 2500 volt mica condenser	J1, J2....	coax jack
C7.....	220 mmf variable condenser, Hammarlund TC-220K	J3, J4....	Closed circuit phone jack
		V1.....	GL-811-A tube

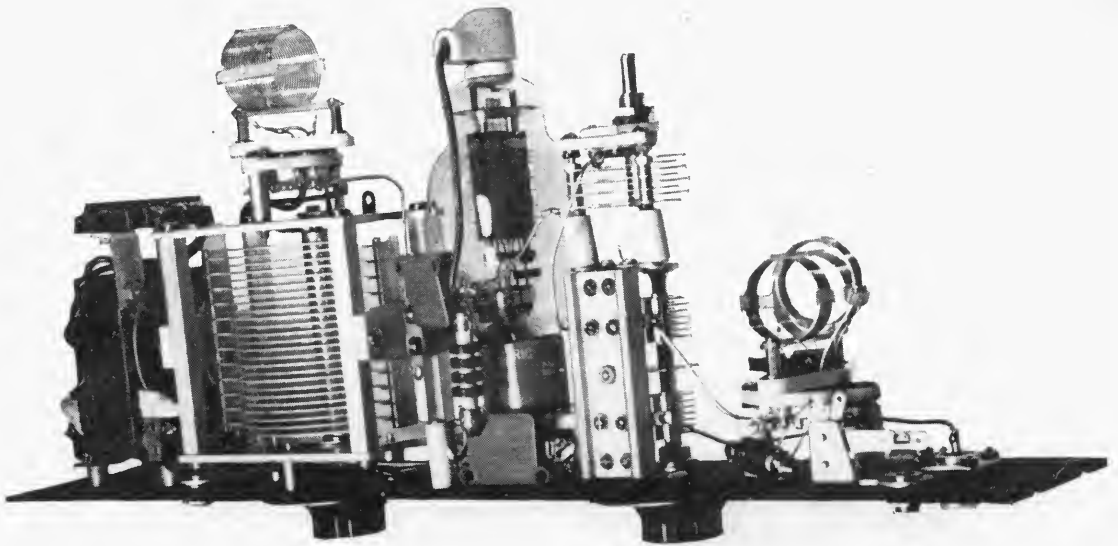

Fig. 3. Bottom view of Power Peaker

COIL DATA

It is essential to use coils having the correct inductance in order to meet the operating circuit Q's. The coils selected require modification in most cases in order to reach the required values. In addition, the two low-frequency-band grid coils require padding condensers mounted on the coil base as shown in Fig. 5.

Band	Coil	L μ hy	Description
3.5-4.0	L4	10	National AR17-40E. Remove end link. Remove 8 turns. Provide 10 taps at $\frac{1}{2}$ turn intervals from Pin No. 2 end. Connect Pin No. 6 to Pin No. 2 across top of coil base. Use a lead connected to Pin No. 1 for connection to taps.

	L1	14.5	National AR17-40S. Remove center tap of swinging link. Connect 150 mmf MICA condenser from each end of coil to Pin No. 3 of coil base. See Figs. 2 and 5.
--	----	------	---

7.0-7.3	L4	4.6	National AR17-20E. Remove end link. Tap each $\frac{1}{4}$ turn for 3 turns and make other connections as described for 3.5-4.0 MC plate coil.
---------	----	-----	--

	L1	7	National AR17-40S. Remove 3 turns from outer ends of each coil half. Remove center tap of swinging link from Pin No. 3 and connect a 50 mmf MICA condenser from each end of coil to Pin No. 3 of coil base. See Figs. 2 and 5.
--	----	---	--

14-14.4	L4	2.7	National AR17-20E. Remove end link. Remove 4 turns. Tap coil every $\frac{1}{4}$ turn for 3 turns and make other connections as described above for plate coils.
---------	----	-----	--

	L1	2.5	National AR17-20S—Remove CT from link.
--	----	-----	--

21, 27-30	L4	0.9	National AR17-10E. Remove end link. Remove 2 turns. Tap each $\frac{1}{8}$ turn for 2 turns and make other connections as described for plate coils.
-----------	----	-----	--

	L1	1.2	National AR17-10S. Remove CT from link.
--	----	-----	---

The inductance values for each coil are given for those who wish to make their own coils.

It might be necessary to remove some of the turns in the swinging links of the grid coils to facilitate matching the exciter into the Power Peaker. Do this if the exciter does not load properly when the link coil is fully meshed with the grid-tank coil.

POWER SUPPLY CONSIDERATIONS

A special word is in order concerning the plate

power supply used with the Power Peaker linear amplifier. The L/C ratio chosen for the plate tank circuit is based on the use of a power-supply voltage of 1500 volts. Use of materially lower voltage (such as 1200 volts) will result in a loaded Q that is too low for proper operation of the amplifier when it is loaded as described under the section entitled **MATCHING AND LOADING**. A serious consequence of low output circuit Q is an abnormally high harmonic output. Thus, to develop rated output power while providing suitable load conditions for the amplifier tube, the power supply should deliver 1500 volts under load.

Good power-supply regulation is desirable for achievement of the best performance from any linear amplifier. A power supply that can deliver, say, 1500 volts at a load current of 200 ma, but which allows the voltage to rise to 1800 volts at the resting or static current of the Power Peaker amplifier will cause even the stand-by dissipation within the GL-811-A to exceed its rating—this will mean a short and unsatisfactory life for the tube. Design of a satisfactory power supply is discussed in G-E HAM NEWS, Vol. 7, No. 2 and **THE RADIO AMATEUR'S HANDBOOK**.

The type of load presented by a linear amplifier with single sideband input is identical to that of a class B modulator stage. To the information given in Vol. 7, No. 2 should be added that dynamic regulation of the power supply be considered also. Without going into details, one will end up with a really satisfactory plate power supply by following the design information given (especially with regard to input chokes, which affects "static" regulation) and then increasing the size of the output capacitor of the filter to a value considerably more than that required for satisfactory ripple performance.

Generally speaking, a power supply which has sufficient input choke to take care of static regulation needs only a single capacitor to meet the ripple requirement. This is provided the total value of capacitance is sufficient to iron out syllabic voltage fluctuations created by the intermittent load characteristic imposed by speech. At W2KUJ, where the Power Peaker was tested, an output capacitance of 25 mfd is used in the power supply to obtain good dynamic voltage regulation. An input choke of 60 henries is used to obtain good static regulation.

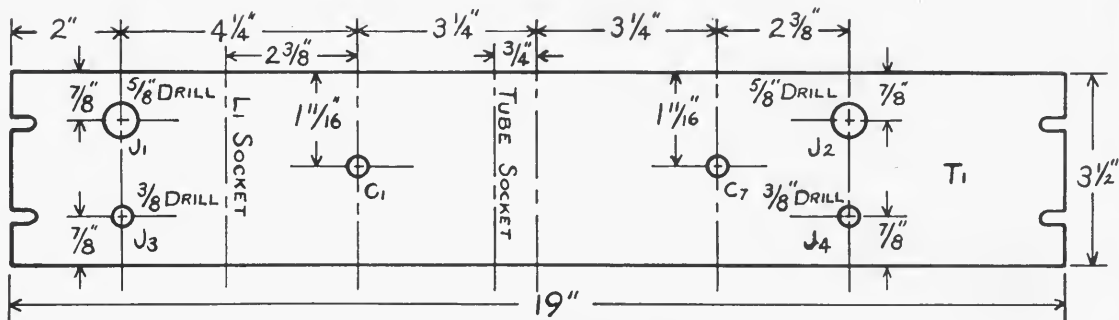

Fig. 4. Panel layout of the Power Peaker (Front Elevation)

Of course, transformer, rectifier tubes, and chokes of sufficient current rating (about 200 ma for the Power Peaker) and filter condensers of adequate voltage rating should be used.

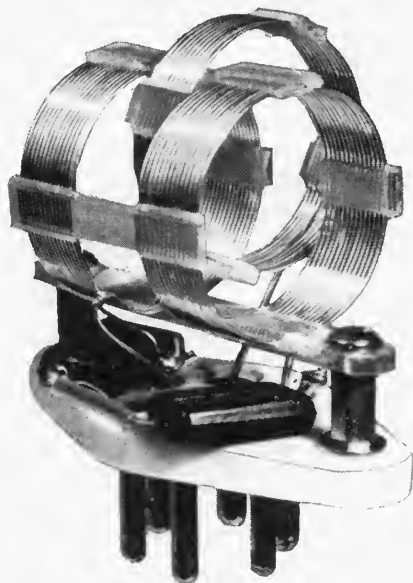

Fig. 5. Modification of grid tank coil

INITIAL TUNE-UP PROCEDURE

After checking the wiring and construction, apply power to the filament circuit. Insert the GL-811-A in its socket and connect the plate cap. Do not apply plate voltage—in fact, disconnect the plate power supply from the terminal board for the present. Plug in the set of coils covering the band you intend to operate and plug in a 0–50 ma meter in the grid current jack (J3). With power applied to the filament, it is normal to see about 2 or 3 ma grid current with no excitation.

Arrange to supply excitation to the amplifier at the desired frequency. Start with the center link loosely coupled and tune the grid circuit to resonance as indicated by maximum grid current. Set the neutralizing condenser about 90 degrees open and check grid circuit resonance. The amount of excitation used at this time is not critical—anywhere from 15 ma to 50 ma (maximum) will do. Adjust the coupling so that this order of magnitude is reached. If a single-sideband suppressed carrier exciter is used, it must be delivering some sort of a signal. A tone modulation, unbalanced carrier, or some reproducible signal will suffice.

NEUTRALIZATION

Disconnect the grid-current meter temporarily, but leave an open-circuited plug in the grid-current jack. Tune the plate tank circuit to resonance or near resonance as indicated by a lamp bulb connected to a loop of wire coupled to the plate coil, an oscilloscope connected to the output jack (use a one-turn tap on the coil) or any other neutralizing stunt you prefer. When fully neutralized, tuning the plate circuit through resonance will not affect the grid circuit. This may be verified by coupling the neutralizing indicator to the grid tank and tuning the plate circuit through its resonance point noted earlier.

With the amplifier neutralized, the plate supply may be connected, the grid-current meter reconnected, and a plate-current meter (0–250 ma) plugged into the cathode current jack (J4). With no excitation, the static plate current will be about 35 ma with 1500 volts applied. It will be noted that the static grid current will drop appreciably when plate voltage is applied. This is normal.

MATCHING AND LOADING

For further test, it is necessary to provide a load for the Power Peaker. Failure to do so will result in damaged coils. A dummy load which has the same resistance as your antenna is ideal for making coupling adjustments. Do not attempt to use incandescent lamp-bulb as a load because its resistance depends greatly on its temperature. An oscilloscope is also needed to check linearity and power when making a test with a two-tone signal. (See S. G. Reque, *Linear R.F. Amplifiers*, QST, May 1949, and R. W. Ehrlich, *How To Test and Align a Linear Amplifier*, QST, May 1952.)

Adjust the single-sideband exciter used as a driver for two-tone operation. Feed this signal into the input jack (J1), at a low level at first and connect the output link to a suitable load. Arrange the oscilloscope so that it can read the r.f. signal across the load. Enough signal will be available to see with the r.f. applied directly to the deflection plates. Apply plate voltage and resonate the grid tank (maximum grid current) and the plate tank (maximum load voltage) with fairly loose coupling to the output circuit.

(CAUTION—HIGH VOLTAGE! ALTHOUGH THE POWER PEAKER HAS BEEN DESIGNED WITH SAFETY IN MIND, IT IS WELL TO RECOGNIZE THE FACT THAT HIGH VOLTAGE IS USED AND THAT ALL "BACK OF THE PANEL" ADJUSTMENTS SHOULD BE MADE AFTER MAKING CERTAIN THAT THE HIGH-VOLTAGE SUPPLY IS NOT ONLY OFF BUT THAT THE FILTER CONDENSERS ARE DISCHARGED. WE DON'T WANT TO LOSE ANY OF OUR READERS JUST YET. STICK AROUND AND FIND OUT HOW WELL THE POWER PEAKER REALLY WORKS. 'NUFF SED?)

An arrangement should be made whereby the exciting signal can be turned off and on conveniently while making loading and matching adjustments. Do not run the test signal any longer at a time than is necessary to see the oscilloscope display and appraise it. Increase the input signal by either increasing the exciter output, or, the coupling in the grid circuit until the peaks of the two-tone output signal show definite flattening. Keeping the input signal at the level where flattening occurs, increase the coupling of the output by moving the tap up on L₄ until the flattening disappears. Go a little further with this coupling. Next, increase the input signal until flattening again occurs and then increase the output coupling and so on. The tuning of plate and grid circuits should be checked for maximum output for each coupling adjustment made. You will note as the job progresses that the peak amplitude of the output signal keeps increasing. Along with this increased output you will note that the plate current has been increasing and so has the grid current. The stopping point is reached when either:

(a) The exciter can no longer deliver an undistorted two-tone signal, or,

(b) The plate current, with a two-tone test signal, has reached a value around 165 ma.

When condition (b) is reached, the tune-up procedure is completed, however, condition (a) requires an investigation of the exciter. Make certain that the Power Peaker is presenting a favorable load to the exciter. This is just a matter of juggling the coupling from the exciter and into the amplifier along with the exciter gain control if it has one. A peak driving power of about 2.5 watts is required, so if the exciter can deliver 5 watts peak power you have only to present the right load to the exciter.

The grid current under correctly loaded condition (b), will be somewhere around 20 ma with a total cathode current of 185 ma. Do not become concerned if the grid current is less than this amount, but if it

is appreciably higher, increase the plate coupling or reduce the input signal or both.

If the procedure outlined has been followed carefully, the amplifier is loaded in an optimum manner. This may be checked by increasing the coupling to the output tank and noting the decrease in r.f. output signal (with fixed drive) and a slight decrease in grid current. Conversely, with fixed drive, decreasing the coupling from optimum will cause an increase in grid current and a flattening of the two-tone peaks as the signal passes through the amplifier. The plate current will drop. Bear in mind the objective is to load the amplifier for maximum output power for any given drive condition up to the maximum input current stated for condition (b). The objective is *not* to load the amplifier simply for maximum input, since the efficiency depends on the loading.

Although reading the tune-up procedure may raise several points not covered, remember that doing the job is probably not as bad as reading about it. The procedure is quite simple, as experience will show, and you will find that the description is quite detailed, perhaps needlessly so. Correct loading is essential to realize maximum output and efficiency together with low distortion.

OPERATING INFORMATION

Very little can be added here to what you already have learned in matching and loading the Power Peaker. Substitution of an antenna for the dummy load and a brief two-tone test with the oscilloscope as a monitor puts you on the air. Never try to exceed with speech signals the maximum peak level attained with the two-tone test. Not only will this fail, but also the quality of your single-sideband signal will be degraded. But worse than that, such practice destroys one of single-sideband's best points—a really narrow, minimum-interference, maximum intelligibility, signal. The Power Peaker linear amplifier can do a good job. Give it a chance and keep your sidebands clean.

Additional Coil Information

ADDED COIL DATA FOR POWER PEAKER LINEAR AMPLIFIER

Coil Substitutions for L₁

Band (Mc.)	National Number	uh	mmf	B & W Number
3.5-4.0	AR17-40S	14.5	145	3118-40JVL- Remove 5 turns each side
7.0-7.3	AR17-40S*	7.0	75	3118-40JVL- Remove 2 turns each side
14.0-14.3	AR17-20S	2.5	53	3116-15JVL- As is
21,27-30	AR17-10S	1.2	46-28	3115-10JVL- As is

Coil taps, padding capacitors and base connections should be made as listed in Coil Table on page 4 of the Volume 7, No. 5 issue of G-E HAM NEWS. Capacity listed is for low frequency end of each band.

*Remove 3 turns from each end.

Coil Substitutions for L₄

Band (Mc.)	National Number	uh	mmf	B & W Number	JEL
3.5-4.0	AR17-40E remove 8 turns	10	210	40BEL remove 4 turns	40JEL remove 4 turns
7.0-7.3	AR17-20E as is	4.6	115	20BEL	20JEL
14.0- 4.3	AR17-20E remove 4 turns	2.7	48	15BEL	15JEL
21,27-30	AR17-10E remove 2 turns	0.9	63-30	10BEL	10JEL

Remove end links and make coil taps as listed in Coil Table on page 4 of Volume 7, No. 5.

* Use the B & W BEL series of coils if CW operation of the amplifier is also desired. JEL series coils will handle the SSB average power only.

COMPACT TRIODE KILOWATT

featuring —
GL-810 Triodes in parallel
Simplified tuning controls

Rapid bandchanging from panel
Complete, simple TVI shielding



TRIODE TRANSMITTING TUBES have been historically associated with large, bulky final amplifier constructional techniques.

"But bulk is not essential," says K210W, "look at the compact triode final in my shack. It fits into a standard 8¾-inch high table rack cabinet, and has a pair of non-critical GL-810 triodes in parallel."

MEET THE DESIGNER . . .

K2IOW again — Bob Hall of Schenectady, N. Y. has gone on from his latest offering, described herein, to whipping up more interesting gadgets at his workbench. The innocent-appearing 'scope in his ham shack (see page 3) includes a special circuit for transmitter monitoring. You'll read about it in an early issue.

MODERN COMPONENTS, plus simplified circuitry, were primarily responsible for the evolution of this compact amplifier which can be operated in any of the popular transmission modes: class C for CW or AM phone; or as a class B linear amplifier for sideband. The two GL-810 triodes in parallel are fully capable of handling the maximum legal input in the above classes of service.

The amplifier can be driven by a transmitter with a power rating of from 75 to 150 watts, the range which spans most of the popular commercial transmitters. No power dissipating network is required, as is necessary when driving most tetrode and pentode kilowatt finals from these transmitters. Also, no screen voltage supply is needed.

TELEVISION INTERFERENCE is a most important consideration these days and the COMPACT TRIODE KILOWATT has passed interference tests with flying colors. It has been operated less than four feet away from a vintage television receiver without causing interference to local channels 6, 10 and 13; nor to a fringe-area signal on channel 2. Some old receivers with a 21-megacycle intermediate frequency may encounter interference from this final, as they would with any high power transmitter on this band.

Band changing and tuneup take very little time, since there are only four panel controls, as identified in the front panel view on page 3. The grid and plate circuit controls can be preset to the correct band from the calibrated indicators. Once an operator becomes familiar with the procedure, it should not be necessary to reduce plate voltage during tuneup.

THE CIRCUIT for the amplifier is quite standard. Since the triode tubes must be neutralized, a push-pull grid circuit, the multi-band tuner (National MB-150), shown in the schematic diagram, FIG. 1,



COMPLETE STATION at K2IOW with the Compact Triode Kilowatt at the right side of the operating desk. Other equipment includes an NC-240D receiver and speaker (extreme left); the 6L6-GC exciter which drives the 810 final; indicator for SWR bridge and High-C Bandswitching VFO atop the exciter; 5-inch 'scope for monitoring; and a 3-foot-high rack cabinet containing (top to bottom) class B GL-805 plate modulator, high voltage supply for the modulator, and a 2,000-volt DC supply for the 810 final.

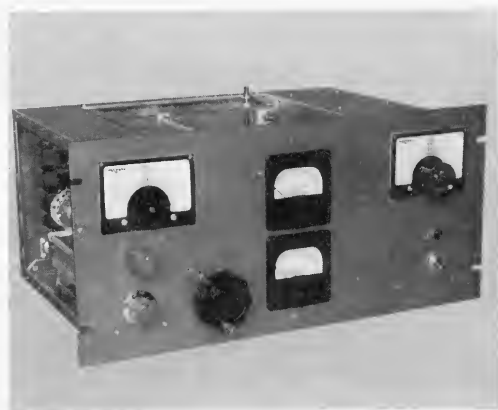

PANEL VIEW of the 810 final. The large knob turns both the rotary inductor and input variable capacitor in the pi-network plate tuned circuit. Indicator dial at left shows band to which plate circuit is tuned. Dial at right is coupled to MB-150 multi-band tuner in grid circuit and provides convenient tuning rate.

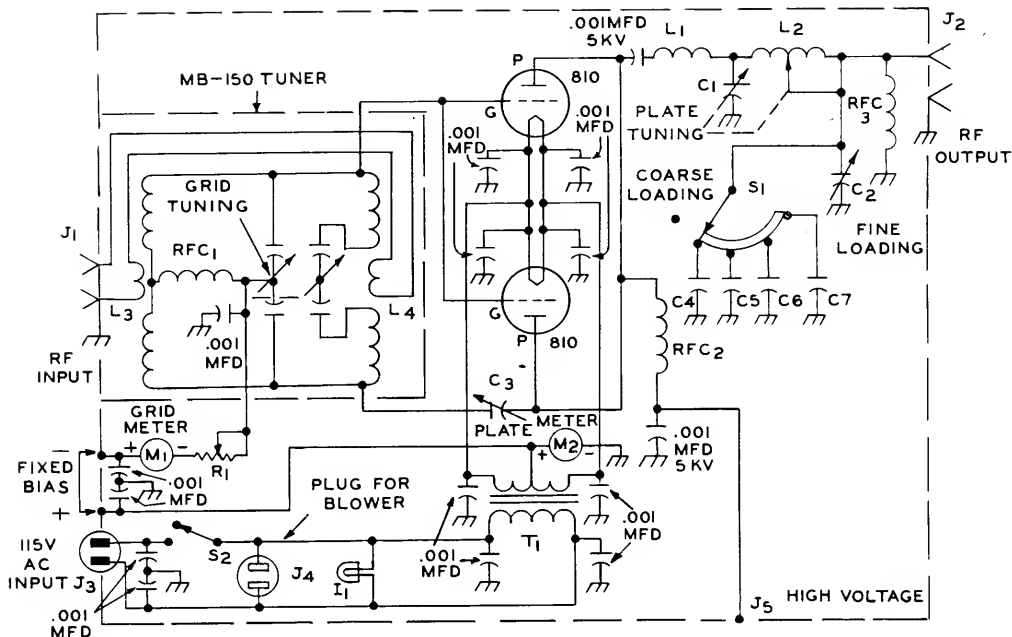

FIG. 1 SCHEMATIC DIAGRAM of the GL-810 triode final. Note that the grid bias return lead is connected directly to the center top on the filament transformer (T_1) without going through the plate current meter (M_2). Thus, M_2 reads only plate current and not combined plate and grid current. All 0.001-mfd bypass capacitors are disc ceramic, 1,000 volts working, unless otherwise specified. All power and meter circuit wiring should be shielded.

PARTS LIST

- | | |
|--|---|
| C_130 — 150-mmf variable, 0.175-inch air gap (Johnson 150D70; or Notional TMA-150). | L_38 turns, No. 16 insulated wire, 1 1/4 inches in diameter, mounted inside center of larger coil on MB-150 tuner. |
| C_220 — 500-mmf variable, 0.045-inch air gap (Johnson 500E20, Cot. No. 154-3). | L_42 turns, No. 16 insulated wire, wound over center of small coils on MB-150 tuner. |
| C_32 — 10-mmf air variable, 0.375-inch air gap (Johnson N375, Cot. 159-375 neutralizing cap). | M_10 — 150-ma DC millimeter (General Electric DO-41 or DO-71, 3 1/2 inches square; or new type DW-91, 2 1/2 inches square). |
| C_4, C_5, C_6500-mmf, 2,500-volt mica. | M_20 — 500-ma DC millimeter (to match M_1). |
| C_70.001-mfd, 2,500-volt mica. | MB-150 National MB-150 multi-band tuner, modified per instructions in mechanical details. |
| I_3115-volt candelabra base pilot lamp and bracket. | R_11,000 ohms, 25-watt potentiometer. |
| J_1, J_2chassis type coaxial cable connector. | RFC $_1$2.5-mh r.f. choke; part of MB-150. |
| J_3chassis type 2-prong male power connector. | RFC $_2$145-uh single layer r.f. choke (National R-175A; B & W No. 800, or Raypar No. RL-100 also suitable). |
| J_4chassis type 2-prong female power connector. | S_111-position, single section progressive shorting tap switch, stop set for 5 positions (Centralab P1S ceramic wafer and P-123 index). |
| J_5single prong high voltage connector (Millen type 37001, red plastic). | S_2single pole, 1 position toggle switch. |
| L_10.3 uh, 3 turns of 0.062 x 0.250-inch copper strip, 1 1/4 inches in diameter, 1 1/2 inches long, 2 turns per inch, with 1-inch leads. | T_110-volt, 10-ampere filament transformer, 115-volt primary. |
| L_215 uh, 5-ampere rotary inductor, 27 turns, No. 12 wire (B & W No. 3852, used in this model; or Johnson Cat. No. 229-202). | RFC $_3$2.5-mh pi-wound r.f. choke (National R-100). |

was necessary. An r.f. voltage of the proper phase and amplitude to prevent regeneration or oscillation is fed back to the lower end of this tuner through C_3 .

Greater link-coupling transfer efficiency was obtained in the multi-band tuner by replacing the original single link, only on the low-frequency coil, with individual links for it and the high frequency coils. This change is described in the construction details.

In the plate circuit, plate voltage is fed to the tubes through RFC_2 . The pi-network is formed by capacitors C_1 and C_2 , plus C_4 , C_5 , C_6 and C_7 in parallel, depending upon the setting of S_1 ; and coils L_1 and L_2 in series. All the capacitors across the pi-network output are needed when matching into low impedance loads — 100 down to 30 ohms — at 3.5 megacycles.

Mechanical ganging was employed between C_1 and L_2 to combine these controls and maintain a nearly constant L/C ratio in the plate tank circuit throughout the frequency range covered by this amplifier.

A pair of worm gears having the proper ratio drives C_1 from maximum to minimum capacitance while L_2 is being cranked from maximum to minimum inductance.

The 28-megacycle inductance, L_1 , was connected between the plates of the GL-810's and C_1 to remove C_1 's minimum capacitance from the input side of the pi-network at this frequency. Thus, only the output capacitance of the two tubes appears across the input of the pi-network. About one half to two turns of L_2 are in the pi-network at 28 megacycles, and C_1 and C_2 are across the output side.

The power connections are identified on the schematic diagram. Fixed negative bias of about 80 volts is sufficient with the GL-810's operating at 2,000 volts on the plates. The bias supply should have good voltage regulation. K2IOW uses the electronically regulated bias supply circuit which has appeared in the "Power Supplies" chapter of *The Radio Amateur's Handbook* (ARRL) for several years.

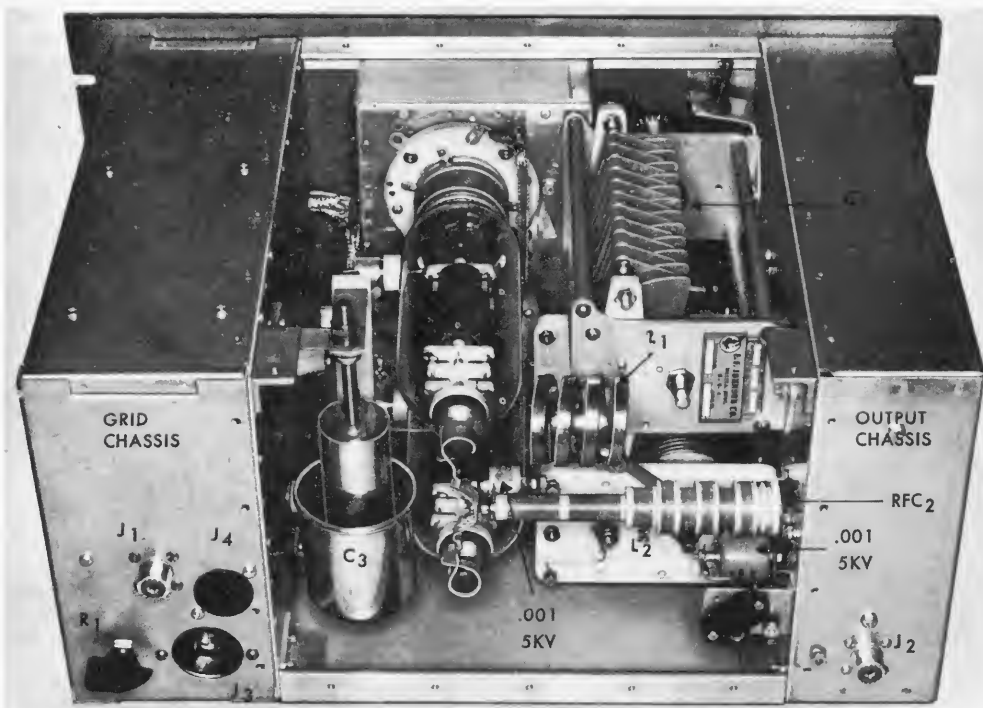

REAR VIEW, looking down into the final. A separate lead runs from each 810 plate cap to the plate circuit r.f. choke (RFC_2). Cylindrical blocking capacitor behind r.f. choke (0.001-mfd, 5,000 volts) connects to one end of 28-megacycle coil (L_1), made from

copper strap. Other end of L_1 fastens to terminal on L_2 . High voltage connector (J_2) is on small angle bracket just below base of r.f. choke, with bypass capacitor behind it. Aluminum angle in foreground connects upper rear corners of the chassis.

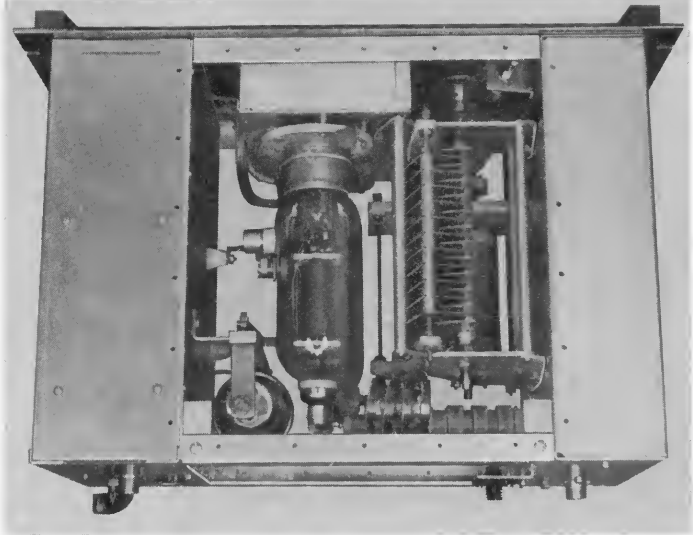

TOP VIEW, showing the white ceramic feedthrough insulator for connection between 810 grid caps and the MB-150 multi-bond tuner, located inside chassis at left. Meters are shielded from r.f. compartment by the 5 x 7 x 2-inch chassis on which the 810 tube sockets are mounted with $\frac{1}{4}$ -inch long spacers.

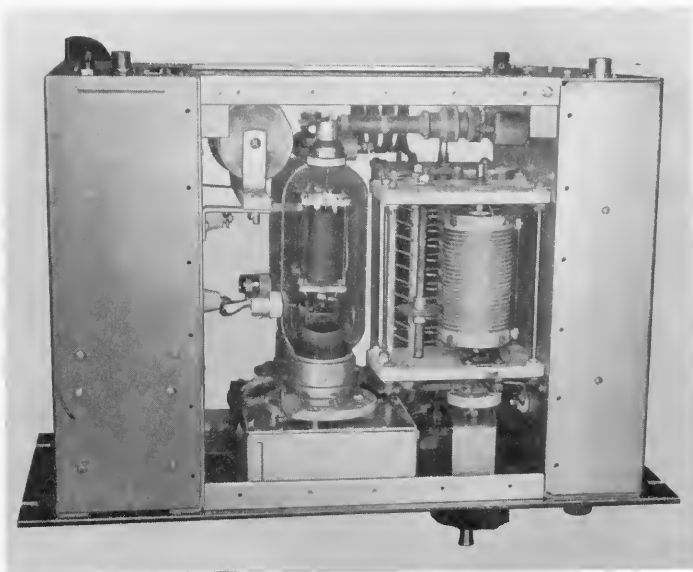

BOTTOM VIEW, showing the shielded leads running from the filament transformer (T_1) inside the grid chassis to the 810 tube sockets. Each filament pin is bypassed individually with shortest possible leads. Neutralizing capacitor (C_a) fastens to grid chassis with 2-inch long angle brackets.

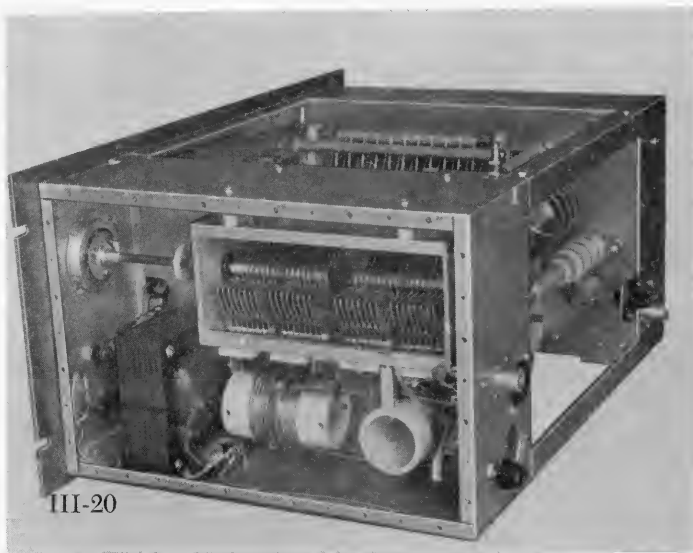

SIDE VIEW of the 4-inch deep grid circuit chassis, showing the modified MB-150 grid tuner. Note the 2-turn link coil (L_4) on the high frequency coil; see **PARTS LIST** for details. Insulated extension shaft runs between MCN dial and shaft on MB-150 tuner.

THE TRIODE KILOWATT was a pleasure to build, and it's a joy to operate. The vertical chassis arrangement lends itself to easy construction, requiring a minimum of framework to support shielding. The usual workshop hand tools, plus a $\frac{1}{4}$ -inch electric drill, were used for all the mechanical work except the meter and indicator dial holes. The latter can be cut with a circle cutter, hole saw or counterbore.

The pictures and accompanying captions on pages indicate placement of the major components in the amplifier. Precise locations of the chassis and holes on the panel, and critical dimensions, can be determined from the top and front view sketches in FIG. 2. The knob shaft which drives C_1 and L_2 may require slightly different placement, depending on the actual parts used, and the gear drive assembly.

BOTH CHASSIS and other components on the panel were fastened with No. 8-32 screws driven into tapped holes in the $8\frac{3}{4}$ x 19-inch aluminum rack panel (Bud PA-1105, or equivalent). All screws were cut off and filed flush with the panel surface before painting. During assembly, the three chassis were lined up and clamped to the back of the panel. Holes were drilled from the panel front with a No. 29 drill and threaded with an 8-32 tap. Use turpentine to prevent the tap from becoming clogged with aluminum chips. Matching holes in the chassis were enlarged.

THE GRID CHASSIS, which had to be 4 inches deep to house the MB-150 tuner, was assembled from *See-Zak* chassis plates and side rails. An 8 x 12-inch plate (P-812) forms the chassis deck, inside the amplifier. A pair of 4 x 8-inch side rails (R-48) form the chassis front and rear; while a pair of 4 x 12-inch side rails (R-412) form the top and bottom side

walls. The outside of the chassis was covered with shielding later.

The MB-150 tuner hangs upside down on pillars $\frac{3}{4}$ of an inch long inside the grid chassis, with the tuning shaft $6\frac{1}{4}$ inches above the bottom wall. Drill holes in the chassis top to match those in the capacitor frame on the tuner. There's sufficient room between the chassis front wall and the MB-150 tuner for a normal-size 10-volt, 10-ampere filament transformer (T_1), but some king-size transformers may not fit. Be sure to allow room for I_1 and S_2 in front of T_1 .

The shield box for the meters — also the mounting for the 810 tube sockets — is 5 x 7 x 2 inches over-all (see detail view on page 9). A *See-Zak* chassis plate (P-57) forms the deck; while the end and side rails are 2 x 5 inches (R-25), and 2 x 7 inches (R-27), respectively. A conventional aluminum chassis of this size can be used, but must be fastened in place with self-tapping screws driven into the bottom lip from the front of the panel.

THE PLATE CIRCUIT pi-network is mounted on the top deck of an 8 x 12 x 3-inch aluminum chassis (Bud AC-424, or equivalent), as shown in the detail view on page 10. The capacitor (C_1) and rotary inductor (L_2) are coupled together through a right angle drive on the shaft of L_1 ; in turn connected through a panel bearing and shaft assembly to a worm (Boston No. LTHB) and a worm gear (Boston No. G-1029) on the shaft of C_1 . The worm gear ratio — 50 to 1 — was selected to enable the rotor of C_1 to turn 180 degrees while the rotary inductor is being cranked through the 27 turns required to move the contact roller from end to end. The shafts on C_1 and L_2 are $4\frac{1}{4}$ inches apart.

INSIDE VIEW of the output chassis, showing the coarse (C_1 - C_2) and fine (C_2) loading capacitors in pi-network. Extension shafts are used to turn C_2 and S_1 . Note method of mounting plate circuit indicator shaft, and pulley for dial card, which runs to same size pulley on shaft of C_1 . (See view of pi-network on page 10).

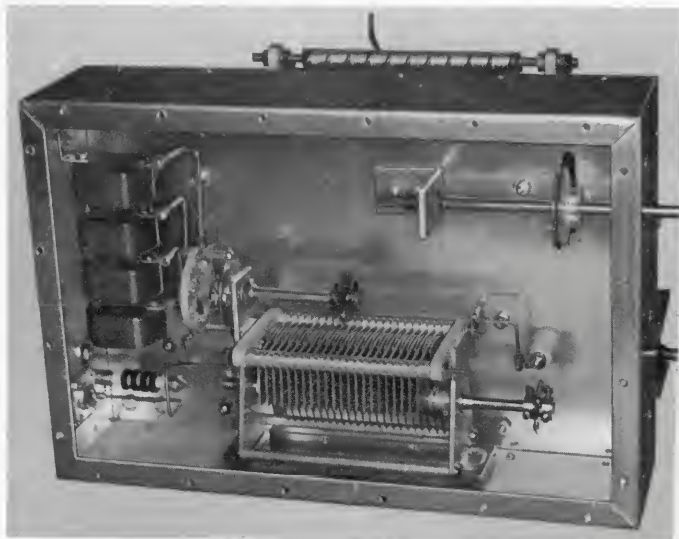

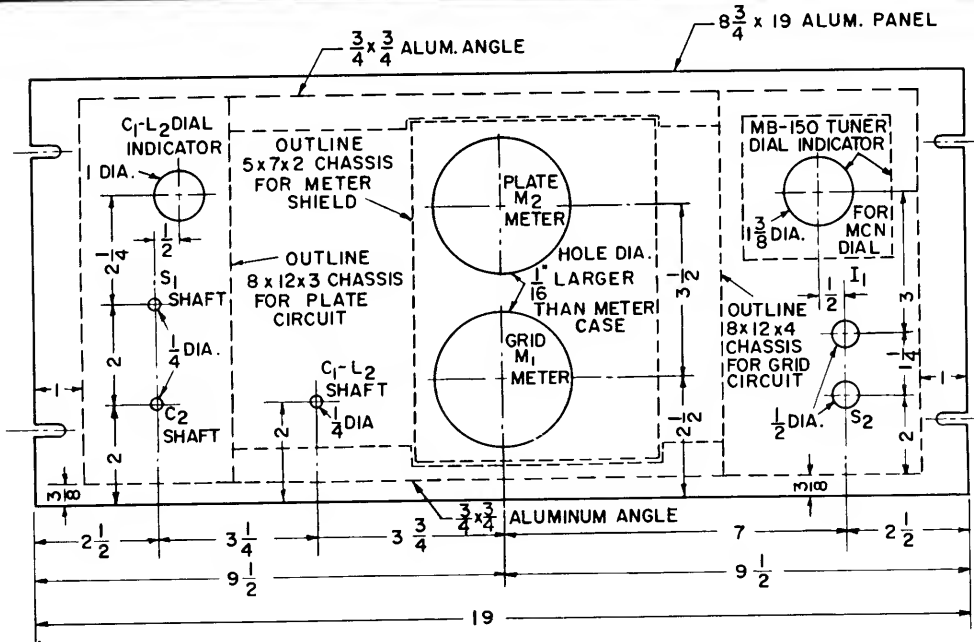
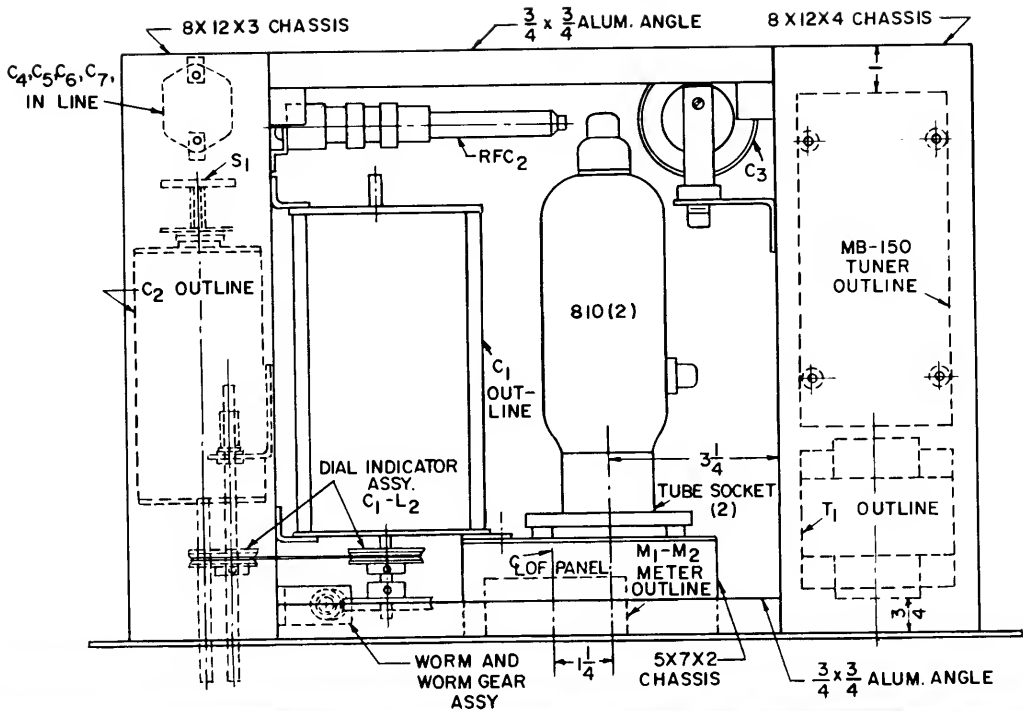

FIG. 2. TOP AND FRONT layout diagrams for the 810 triode final. Positions of all major components have been indicated, but may vary in accordance with the sizes of parts actually used in duplicating this amplifier. Panel layout allows room for meters with $3\frac{1}{2}$ -inch diameter flanges on cases. Spacing between the shafts on C_1 (top) and L_2 (bottom) is $\frac{1}{4}$ inches. Note notches in angle behind panel to clear meter shield.

The knob shaft for L_2 was run through a box-section aluminum extrusion which houses the miter gears (2-Boston No. G-464). However, the lower end of the vertical shaft could be supported by a panel bearing mounted in an angle bracket similar to that at the upper end of the shaft. A panel bearing on the knob shaft for L_2 could support it at the panel.

Alignment of the miter gears is accomplished simply by sliding them into the proper relative positions before tightening the set screws. The worm gear on C_1 is then lined up with the vertical shaft. Provide a slot in the upper angle bracket for the vertical shaft. This permits the shaft to be moved for proper meshing of the worm gears. Finally, tighten the nut on the upper panel bearing to lock the shaft in this position.

The capacitors, switch and other parts in the pi-network output section are mounted inside the plate circuit chassis. Parts locations and assembly details are shown in the end view on page 7.

Once all the holes in the panel and chassis have been drilled, the chassis should be temporarily assembled to the panel. Four 10-inch lengths of $\frac{3}{4} \times \frac{3}{4}$ -inch soft aluminum angle (do-it-yourself type) should then be cut. Two of them are fastened to the panel, as shown in the detail photo below. The others are fastened between the upper and lower rear corners of the chassis with small angle brackets cut from the same material. Shields are then cut from perforated sheet aluminum (do-it-yourself type) to cover the top, bottom and rear openings between the chassis; also the open ends of the two chassis. Drill holes for No. 6-32 machine screws in the aluminum angle; and for self-tapping screws in the chassis, spaced not more than $1\frac{1}{2}$ inches, using the perforated shields as templates.

SMALL PARTS, such as angle brackets, should be fabricated to fit the parts being

mounted. Remove the aluminum base from C_3 and make two angle brackets to support it from the grid chassis deck. A frame for the plate tuning indicator to match the grid tuning MCN dial was made by tracing around the MCN frame onto a piece of sheet aluminum. This frame was cut out and painted black wrinkle.

The hub for the plate tuning dial pointer was made from a Lucite disc $1\frac{1}{2}$ inches in diameter. It also was finished in black wrinkle paint. The pointer is of clear plastic to match the MCN dial pointer, with an indicator line scratched on it, and filled with black paint. The pointer was cemented to the back side of the hub. The hub was fastened to the indicator shaft with a 4-40 machine screw driven into a hole tapped in the end of the shaft.

Two plastic pulleys about 2 inches in diameter — one on the shaft of C_1 , and the other on the plate tuning indicator shaft inside the plate circuit chassis — drive the dial pointer. They can be adapted from table radio dial cord pulleys, or turned from sheet Lucite. Because the indicator rotates through only 180 degrees, the dial cord can be fastened at one point on each pulley to prevent slippage.

Modify the MB-150 tuner by removing the original link coil and substituting L_3 inside the low-frequency coil form. Make the leads on L_3 long enough to run out of the form, with one wire going to the r.f. input jack, J_1 ; and the other to L_1 . Install L_1 between the two coils on the high-frequency coil form, as shown in the grid circuit view at the bottom of page 6.

FINAL ASSEMBLY of the parts on the two chassis may begin after the burrs are removed from all holes. All parts should be mounted and the wiring completed before fastening the grid chassis to the panel. Be sure to leave the shielded leads to the meters and 810 tube sockets long enough. Next, install the panel and meters, wiring

DETAIL VIEW showing the sockets for the 810 tubes positioned so that the plates lie in a vertical plane. This prevents possible grid-to-filament short circuits due to filament sag when filaments are hot. Details on grid chassis and meter shield boxes are given in the constructional details. Outside cup on C_3 connects to plates of 810 tubes; inside cup to MB-150 tuner through small feedthrough insulator.

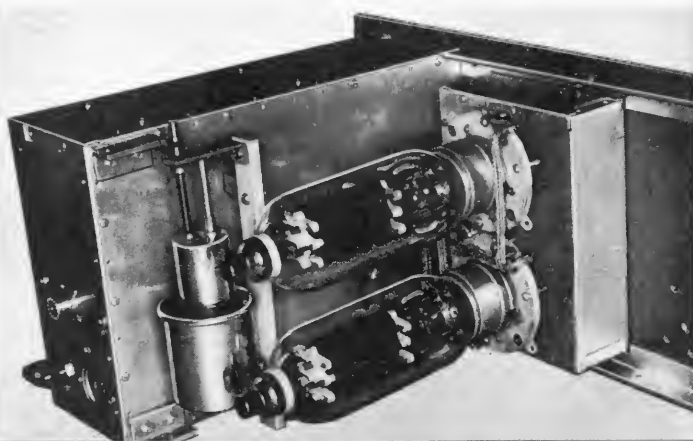

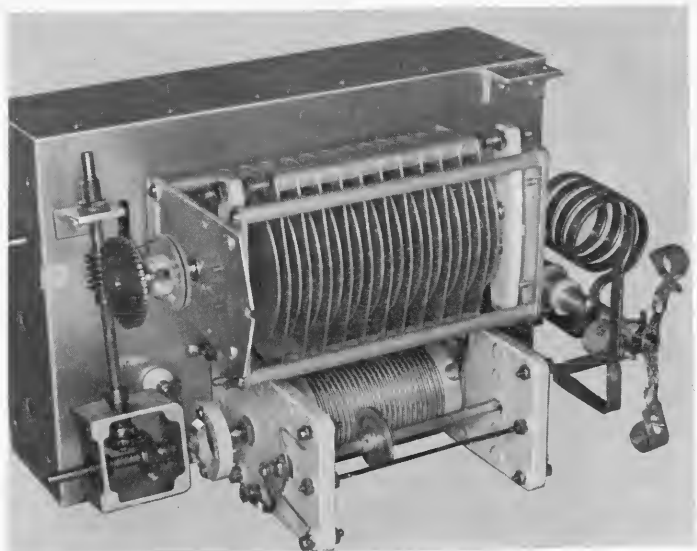

DETAIL VIEW of the pi-network assembly and the gear drive between the shaft which turns L_2 and C_1 . Shafts for the miter gears can be mounted on angle brackets, instead of the box-type housing shown. Note pulley for indicator dial with diol cord crossed for proper rotation of pointer. Insulated shaft coupling must be used on shaft of L_2 . Feedthrough insulator behind gear box is for connection from L_2 to stator of C_3 .

them before assembling their shield box. Mount the 810 sockets on the 5 x 7 shield cover and fasten it in place.

After the plate circuit chassis is in place, the $\frac{1}{16}$ x $\frac{1}{4}$ -inch, copper strap leads between the plate circuit components may be fitted in place. Flexible copper strap or braid should be used for the 810 grid and plate leads. One end of L_1 fastens to the 0.001-mfd ceramic capacitor at the top of RFC₂; the other end is bolted to the strap connecting the stator of C_1 and the input end of L_2 .

Forced ventilation of the table rack cabinet was accomplished by fastening a small fan — a phono motor with a 3-inch diameter fan — over a 3 $\frac{1}{8}$ -inch diameter hole in the back of the cabinet, in line with the lower 810 tube. A short duct made from a 3-inch diameter can was fastened inside the cabinet, extending to within $\frac{1}{8}$ of an inch of the amplifier shielding.

PRELIMINARY TUNEUP should be completed without the shields in place. Turn the plate tuning control until L_2 is about $\frac{1}{2}$ -turn from minimum inductance. Install the GL-810 tubes, turn C_2 to the half-meshed position, and set S_1 so that none of the fixed loading capacitors (C_4 - C_7) are in the circuit. Obtain a grid dip meter covering the 30-megacycle range and hold its coil near L_1 . A dip should be observed between 30 and 32 megacycles. If the dip is below 30 megacycles, spread the turns on L_1 and recheck. If necessary, decrease the diameter of L_1 slightly to shift the dip to above 30 megacycles.

Apply 115-volt AC power, bias voltage and about 50 to 75 watts of r.f. driving power at 14 or 21 megacycles through J_1 . Do not connect plate voltage at this time. Tune the MB-150 to resonance, as indicated by maximum grid current on M_1 . Leave C_2 and S_1 set as above and, while turning the plate tuning control with the

roller on L_2 about 6 or 8 turns from minimum inductance, watch M_1 for a fluctuation in grid current. Starting with C_3 at maximum capacitance, turn it toward minimum capacitance while rocking the plate tuning back and forth until virtually no fluctuation in grid current is observed.¹ The amplifier is now neutralized.

Shielding may now be installed and the neutralization adjustment rechecked. A small hole was cut in the top shield over C_3 for this purpose. Connect a suitable dummy load² to J_2 and apply about 1,000 volts to J_3 . With the same r.f. drive used for neutralizing, tune the MB-150 for maximum grid current, then tune the plate circuit for a dip in the plate current reading on M_2 . Turn C_2 toward minimum capacitance to increase the loading to about 200 milliamperes plate current, readjusting the plate tuning for a dip.

If the amplifier is operating properly, increase the plate voltage and current to the normal rating for the class of service in which the amplifier will be operated. A fixed bias supply is recommended, especially for CW operation; and it is essential for class B linear operation.

Normal tuneup consists simply of adjusting the exciter to supply the required driving power, tuning the grid and plate circuits to resonance, and loading with the coarse and fine loading controls.

Type GL-8000 triodes, electrically and mechanically similar to the GL-810 except for amplification factor (μ), were tested in the amplifier and found to require somewhat less driving power.

¹Other procedures for neutralization are given in the amateur radio handbooks.

²Four 150-watt lamps in series-parallel; or, see "Using Resistors as RF Loads," G-E HAM NEWS, January-February, 1951 (Vol. 6, No. 1), for other ideas.

1. A terminal into which fixed bias is applied to the control grids of the GL-810 tubes does not appear in the rear view on page 5, but was added by K21OW just above the bias adjustment potentiometer, R₁.
2. K21OW has since converted this amplifier from class C operation into a class B linear simply by shunting the MB-150 grid tank circuit with a 5,000-ohm, 25-watt non-inductive resistor. The resistor was placed between the GL-810 grid connection, and the connection to the neutralization capacitor, C₃, at the lower end of the MB-150 on the schematic diagram, Fig. 1, on page 4 of this issue. Normal bias for class B audio operation is given in the table below. Potentiometer R₁ should be set at minimum resistance.
3. GROUNDED-GRID OPERATION--Either GL-810 or GL-8000 triodes can be operated in a grounded-grid linear amplifier circuit constructed much the same as K21OW's amplifier, except that the grid tank circuit and neutralizing components are eliminated. Each tube grid is bypassed to ground separately through a 0.005-mfd disc ceramic capacitor with shortest possible leads. Normal class B bias is applied to the grids. A B & W FC-15 filament RF choke is inserted in the filament circuit, following normal grounded-grid techniques, and the r.f. input is fed from the coaxial cable input jack to both sides of each tube filament through 0.001-mfd disc ceramic capacitors.

TABLE I - CLASS B GRID BIAS FOR GL-810 and GL-8000

Tube Type	Operating Plate Voltage					Volts
	1,500	1,750	2,000	2,250	2,500	
GL-810	-38	-44	-50	-60	-70	Volts
GL-8000	-90	-105	-120	-130	-150	Volts

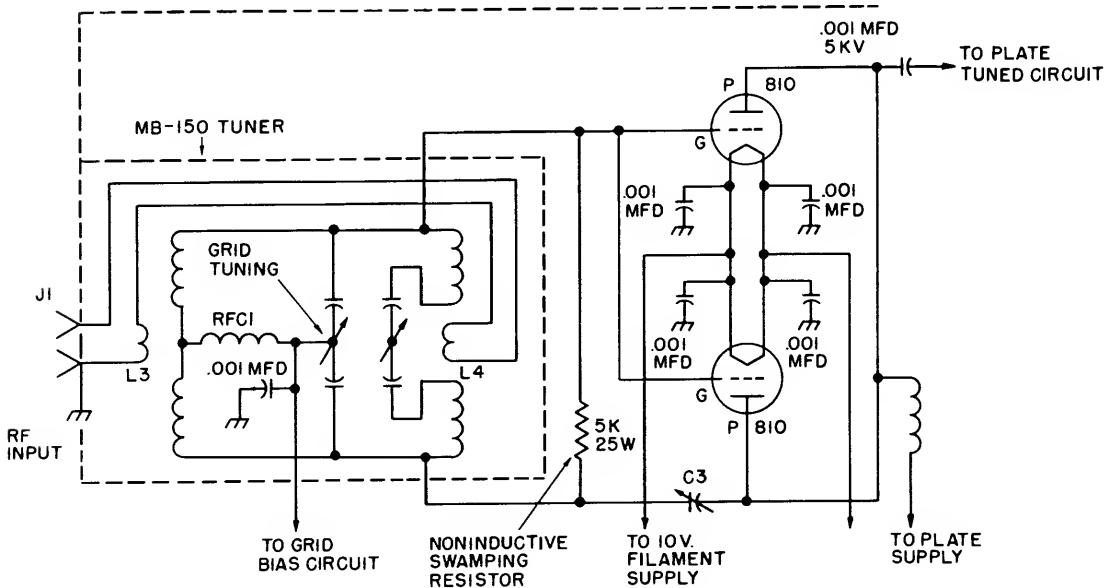

COMPARISON OF DSB AND SSB

Boy! What would we hams do for rag-chewing topics if new technical developments were not constantly coming along for us to hash over! Lately, one of the most popular topics for discussion—on the air, at radio club meetings, or wherever a group of amateurs congregates—is double-sideband, suppressed-carrier transmission and reception (DSB)¹.

Undoubtedly the big advantage of both SSB and DSB signals over conventional AM is that absence of that old heterodyne-producing carrier. Spacewise, the two sidebands of AM and DSB signals normally will make these signals twice as broad as that from a properly-adjusted SSB transmitter having adequate unwanted sideband suppression (30 db or greater). Overdriving a linear amplifier following either a SSB or DSB exciter usually results in a much too-broad signal containing an abundance of distortion products. (We've heard this condition far too often lately, so watch that gain!)

To many amateurs the big decision seems to be, "Should I convert my present AM rig to SSB or DSB?; and, which system offers the best results, plus the least complicated conversion?" The "best results" question is highly controversial², but two simple methods have been suggested for converting an AM transmitter to DSB, both of which utilize a greater portion of an existing AM rig than a similar conversion to SSB.

The same basic type of balanced modulator circuit is used in both DSB systems, but the DSB signal may be generated in either the final amplifier stage³, or a low-level exciter stage⁴. The low-level DSB signal is then amplified by operating succeeding stages as linear amplifiers, as in an SSB transmitter.

In contrast, even a low-power, all-band SSB exciter is quite complex, and the amateur who has built his own really deserves a pat on the back! The abundance of commercially-built SSB exciters on the air verifies this fact.

However, a one-band SSB exciter can be quite simple (see SSB, Jr., G-E HAM NEWS, November-December, 1950, Vol. 5, No. 6) without the extra frequency conversion and spurious signal problems that usually arise when designing an SSB exciter for several bands. This is an easy way for the build-it-yourself radio amateur to get started on SSB, since the phasing type circuit in the SSB, Jr., can later be incorporated into a heterodyne-type exciter for two or more bands.

The reception of DSB signals on a garden-variety communications receiver (one that will respond to both sidebands at once) is not so delightfully simple, however. The carrier that you re-insert with the receiver's BFO should be exactly the same frequency and phase as the DSB transmitter carrier for best readability. Mis-tuning a DSB signal only a few cycles on such a receiver results in greatly reduced audio intelligibility⁵. This problem can be avoided by means of a receiver or adapter unit that has a complex carrier phase synchro-

nization system. For the radio amateur, a much easier solution to receiving DSB signals is to use a SSB receiving adapter. This deliberately ignores one sideband of a DSB signal—and it lets you select the sideband on which there is least interference. Both SSB and DSB signals can be mis-tuned nearly 100 cycles on most receivers equipped with an SSB adapter and still be readable, even though the voice may sound like Donald Duck!

Thus, a DSB signal usually is as simple to generate as a conventional AM signal, and somewhat easier than generating an SSB signal. Conversely, DSB signals are more difficult to receive properly than AM or SSB signals without a special adapter on your receiver.

Now that we've briefly outlined the relative simplicity of the equipment required for SSB and DSB operation, let's talk a bit about what happens when you put either type of rig on the air. A lot of the SSB boys contact each other en-masse in round-table QSO's, some of which collect staggering numbers of participants! The ensuing conversations often greatly resemble the good old-fashioned party-line telephone circuits! Operating thusly practically requires all stations to be equipped for voice-controlled break-in operation.

After listening to—or operating in—one of these round tables, the advantages over the old system of long-winded alternate transmissions are obvious (and this applies equally to CW break-in). Being able to warn the other fellow instantly when some QRM lands on the channel is much easier than straining to maintain solid copy through heterodynes and other hash. It also eliminates note-taking—or relying on your memory—to be sure of commenting on all subjects the other fellow has covered. —And how many times have you patiently sweated out listening to a long transmission without being able to break in right after the XYL has told you that the steaks are on the table—and you had better get there fast before everything gets cold? Need I say more?

Of course, most boys using DSB transmitters also will want to equip their stations with voice-controlled break-in so that they can jump right into the round-table QSO's. There should be practically no detectable difference in sound between a SSB and DSB signal when copied on a SSB receiver, except that a DSB signal will be readable on both lower and upper sideband positions.

We seldom hear a roundtable QSO in which all three types of stations—AM, SSB and DSB—are participating. For this, it is simply desirable that all stations be within a few cycles of the same carrier frequency, and that voice-controlled or other means of fast break-in be employed. This could and should be a good way to make new acquaintances—as well as renew old ones—among amateurs using other modulation methods, and similarly increase your enjoyment of amateur radio as a hobby. Finally, let's coin an appropriate slogan, which obviously is: "Live modern—supress that carrier a d install rapid break-in at your station."

—Lighthouse Larry

¹Costas, "Synchronous Communications," *Proc. IRE*, December, 1956, page 1713.

²Costas, "Single-Sideband: Is It Really Better than Amplitude Modulation?" *CQ*, January, 1957, page 26.

³Najork, "100-Watt DSB Mobile," *CQ*, March, 1957, page 52.

⁴Stoner, "DX-100 to DSB," *CQ*, April, 1957, page 54.

⁵Grammer, "Suppressed-Carrier AM," *QST*, March, 1957, p. 21.

Maximum Ratings and Typical Operating Conditions for Transmitting Tubes

From September-October, 1950

Question: How are the Maximum Ratings that are generally included in transmitting tube data arrived at? Is it ever permissible to exceed these ratings and, if so, in what type of service and with what probable result as regards tube life?

Answer: The data sheet of almost any transmitting tube contains information of two types. One set of information is the Maximum Ratings referred to in the question, and the other set of information is called Typical Operating Conditions. The Maximum Ratings are intended to be just what the name implies, that is, ratings that should not be exceeded. Typical Operating Conditions are examples of various voltages and currents that are likely to occur when the tube is operated as specified. Let us discuss both types of information.

Maximum Ratings are placed on plate voltage, screen voltage, and grid voltage. These voltage ratings are those which the tube manufacturer knows it is safe to use, from the standpoint of the physical and mechanical properties of the tube. For example, if the rated maximum plate voltage is stated as 3000 volts, then the tube in question may be operated safely at this voltage. If a higher voltage were to be used, a voltage fault of some sort might occur, such as excessive leakage across an insulator, or perhaps even an arc between electrodes.

The same sort of reasoning applies to screen voltage and grid voltage. Of course, some safety factor is included in these ratings, but this safety factor is one which has been computed for the particular tube type in general. If you were to exceed some maximum voltage rating, it might just be that you would do it on a tube that was very close to the limit on internal spacing, and a voltage failure would occur.

Maximum Ratings are also placed on the various currents, such as plate current, screen-grid current and grid current. The tube manufacturer does his design work in terms of peak currents, and these allowable peak currents depend upon the amount of emission available from the filament. Knowing the available emission, the manufacturer computes the peak currents allowable, and then transfers these peak current figures into d-c current values which are then used as Maximum Ratings. This philosophy holds for plate and screen-grid currents, but the maximum allowable control-grid current is figured on a different basis.

The control grid is a relatively fragile element. It is capable of dissipating only so much energy before it melts or deforms. Therefore the Maximum Rating for control-grid current is set at a figure which will not permit the grid to overheat.

In exactly the same fashion, the Maximum Allowable Plate Dissipation is a figure which the plate or anode of the tube can dissipate safely without overheating.

Maximum Allowable Input is a rating based upon operation of the tube at the maximum expected efficiency. That is, if the maximum efficiency possible is known to be seventy-five percent, and the maximum allowable plate dissipation is 250 watts, then the maximum allowable input would be one kilowatt.

Another rating frequently given is the maximum frequency at which it is permissible to use the other Maximum Ratings. This rating is brought about because as tubes are operated at higher and higher frequencies, they reach a point where the efficiency begins to fall off rapidly. At this frequency it is necessary to derate all Maximum Ratings, else the various elements will overheat due to the lower efficiency.

From the above discussion it is obvious that Maximum Ratings cannot be used together. That is, if the maximum voltage is 3000, and the maximum plate current is given as 300, it would not be possible to run the tube at 3000 volts with a plate current of 300 mls, because by so doing you would be exceeding either the plate dissipation or the maximum allowable input.

To save the user of the tube from the bother of computing a set of operating conditions that are safe, the tube manufacturer has done this for a number of different voltages, and these are called Typical Operating Conditions. Let us examine a set of these for the GL-810.

For a d-c plate voltage of 2000 volts and a d-c grid voltage of minus 160, the peak r-f grid voltage should be approximately 330 volts. Under these conditions the d-c plate current should be adjusted to 250 mls. The typical grid current is listed as 40 mls, and the power output is shown to be 375 watts.

These are the conditions that you would find if your transmitter used a GL-810 that was exactly an average tube in all respects. However, rarely will you have a tube that has average characteristics. For that reason, do not be surprised if some of the currents do not turn out to be exactly as specified. In other words, if you apply a driving voltage of 330 volts, and you measure the d-c grid current and find it is as rated, that is, minus 160 volts, then it is quite possible that the d-c grid current could be 35 or 45 instead of the 40 mls specified.

The Typical Operating Conditions are intended as a guide to the tube user. They are not intended to be hard and fast figures. Use them merely as a guide, but observe carefully the Maximum Ratings, because they are intended to keep the tube safe from harm, for your protection.—Lighthouse Larry.

Computing Driving Power for Transmitting Tubes

From July-August, 1947

Question: How do you compute the driving power for RF amplifier circuits? All technical information sheets give data for single tube operation only. I am interested in both push-pull and parallel operation.

Answer: To compute the drive requirements when more than one tube is involved it is necessary to use the following data from the typical operating conditions for a single tube: Grid bias, peak r-f grid input voltage, grid current and driving power. The following two examples are based on the data for class C telegraphy use of the GL-812 using 1500 volts on the plate. For a typical case, a single tube requires a d-c grid bias of -175 volts, a peak r-f grid voltage of 285 volts, a grid current of .025 amperes, and a driving power of approximately 6.5 watts.

If GL-812 tubes are used in push-pull, the d-c

grid voltage will still be the same (-175 volts) but inasmuch as the grid current will be doubled (.050 amperes) the grid resistor should be one-half the value of that used with a single tube. Assuming no fixed bias, this resistor, for push-pull operation, would be computed by $R = E \div .05$. (3500 ohms). The required peak r-f grid voltage per tube (grid to ground) will be the same but the peak r-f grid to grid voltage will now be 570 volts. This means that the driving stage must be capable of supplying an r-f voltage of at least that amount. Driving power requirements are doubled, hence at least 13 watts is now required.

For parallel operation of two tubes, grid bias is still -175 volts and the grid current is again doubled, requiring a grid resistor of 3500 ohms. The peak r-f grid voltage required is 285 volts, but as before, the driving power required is double, or approximately 13 watts.

—Lighthouse Larry.

Frequency Limitations on Transmitting Tubes

From September-October, 1946

Question: As the frequency is continually increased will various tubes reach a certain limiting frequency and cut out in all their functions simultaneously or will certain tubes amplify at higher frequencies than they would oscillate or vice versa?

Answer: Every tube has its own resonant frequency—that is, a maximum frequency at which it will oscillate. This limit is brought about by tube capacitance and inductance and at this limiting frequency the entire circuit is effectively contained within the tube envelope.

It is possible that a tube would act as an amplifier at a slightly higher frequency than it could oscillate, but the difference in these two frequencies would be small. The important point is that the efficiency at these limiting frequencies is so very poor that it would not be practical to operate the tube at frequencies even close to the limiting or resonant frequency of the tube.

—Lighthouse Larry.

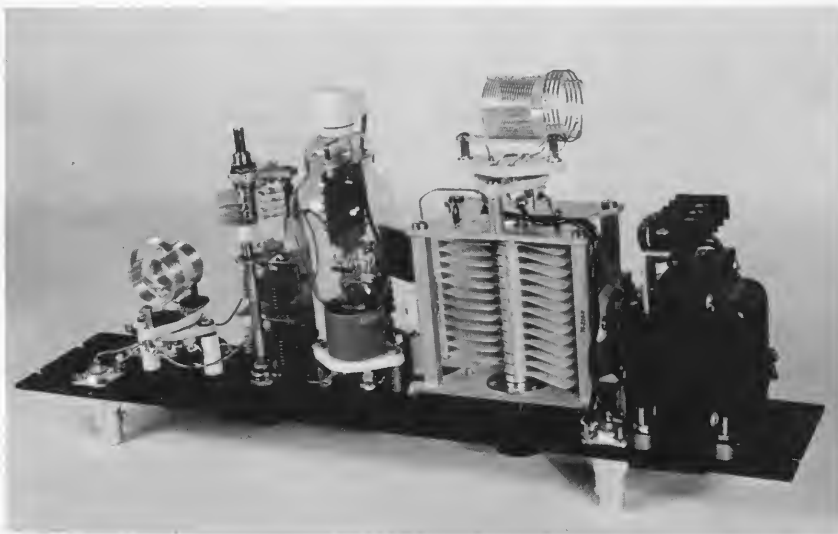

Top view of the Power Peaker Linear Amplifier described fully on pages III-10 to III-15 in this chapter.

PENTODE LINEAR AMPLIFIERS

KILOWATT GROUNDED-GRID LINEAR AMPLIFIER
WITH PARALLELED GL-813's



GL-813 pentodes have been popular with radio amateurs for years. And their smooth adaptability to grounded-grid linear amplifier circuits should continue their well-earned reputation for versatility.

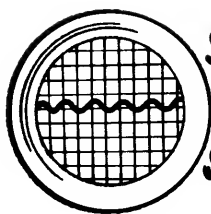

SCANNING the SPECTRUM

Some Comments on — GROUNDED-GRID OPERATION of TETRODE AND PENTODE TUBES IN LINEAR AMPLIFIERS

There has recently been greatly increased interest and popularity of using tetrode and pentode transmitting tubes in grounded-grid linear amplifier circuits. The information below has been compiled to serve as a guide to operating other tetrode and pentode tube types in the circuit published in this issue for the GL-813 beam pentode.

CAUTION: Although the 813 operates satisfactorily with the high- μ triode connection shown in the schematic diagram, Fig. 1, on page 4 of this issue, some other tube types should not be operated as high- μ triodes. With some tube types, the control grid may draw excessive grid current when the cathode is driven with sufficient power for grounded-grid operation. This is especially true when the tube is operated as a zero-bias high- μ triode (both control grid and screen grid grounded directly), since grid current can begin flowing as soon as driving power is applied because there is no grid bias voltage to overcome. A majority of the combined control-screen grid current, as read on a single meter, may flow through the control grid, thus greatly exceeding the grid dissipation rating of the tube. It is a good idea to determine experimentally, with meters connected in both control grid and screen grid DC connections to ground, how much current is drawn by each grid with the grounded grid amplifier operating with normal drive, plate voltage and plate current.

The use of fixed bias on the control grid in the GL-813 amplifier circuit tends to limit the control grid current, and keep grid dissipation within ratings.

A tabulation of the DC connections recommended for the popular types of amateur radio power tubes is given in TABLE 4. Technical data sheets for specific tube types can be obtained from the manufacturer of that type. For General Electric types, write to: Technical Data Section, Power Tube Department, General Electric Company, Schenectady, New York.

TABLE 4		RECOMMENDED DC CONNECTION FOR PENTODE AND TETRODE TUBES IN GROUNDED-GRID AMPLIFIER SERVICE
TUBE TYPE		COMMENTS
4-65A 4X150A 4D21/4-125A 701A	4-400A 4-1000A 5D22/4-250A	Only tetrode connection recommended, triode connection not recommended, but may be possible with careful checking of grid currents. Fixed bias should be used for triode connection, as in 813 circuit.
803 813 814	828 837	Triode connection suitable, first check grid current. Pentode connection also recommended.
807 1625		Not recommended for grounded-grid operation because of beam forming plates connected internally to cathode; may cause instability. Some tubes can be modified if these connections are brought out of bulb on separate leads; see QST and ARRL SSB Handbook for details. With modification, recommended for triode connection.

KILOWATT GROUNDED-GRID AMPLIFIER

Using only hand tools, an amateur can construct a high quality flexible linear amplifier in less time than it takes to round up the relatively few parts required.

The popularity of amateur transmitters in the 75- to 150-watt power class usually provides a ready-made exciter when the time comes to add a more powerful final amplifier to the amateur station. Because pentodes have a low driving power requirement, a power dissipating device must be employed when these tubes are driven from a 100-watt class rig.

A grounded-grid amplifier circuit provided a satisfactory solution; and, experience indicates that the GL-813 operates efficiently in grounded grid.¹ Also, this tube operates well as a high- μ triode, thus eliminating the need for a separate screen voltage supply.

To provide for a 1-kilowatt power capability as a linear amplifier, two GL-813 tubes are connected in parallel and operated in a grounded-grid circuit, with both the screen grids and beam forming plates at zero DC and r.f. potential. The tubes run in class B at an efficiency of 60 to 70 percent, depending upon the plate voltage.

THE CIRCUIT, shown in the schematic diagram, Fig. 1, is quite simple, since no

tuned grid circuit is required. The r.f. driving power is fed directly into the filaments of the two GL-813's. A dual r.f. choke (RFC₂) in the filament circuit isolates the filament transformer.

High voltage is applied to the GL-813 plates, connected in parallel, through RFCs. Three blocking capacitors in parallel keep high voltage from reaching the pi-network tuning plate circuit. A ready-made tapped coil (L₁) and split-stator tuning capacitor on the input side of the pi-network provide nearly optimum L/C ratios on all amateur bands from 3.5 to 30 megacycles. One section of C₁ is in the circuit on 14, 21 and 28 megacycles, when S₂ is open. Both sections are in parallel on 3.5 and 7 megacycles, where greater maximum capacitance is required, S₂ being closed by a linkage from the switch on L₁.

A large variable capacitor (C₂) — 1500 mmf maximum — across the output side of the pi-network eliminates the need for several fixed capacitors, and a tap switch to add them to the circuit as needed. The output circuit will match impedances from 50- or 70-ohm unbalanced feedline and loads.

THE CONTROL GRIDS on the GL-813's, bypassed to the chassis at each tube socket, receive from 0 to 100 volts of negative bias from the built-in bias supply, depending

¹As in the Barker & Williamson, Inc., models L-1000A, L-1001A and LPA-1.

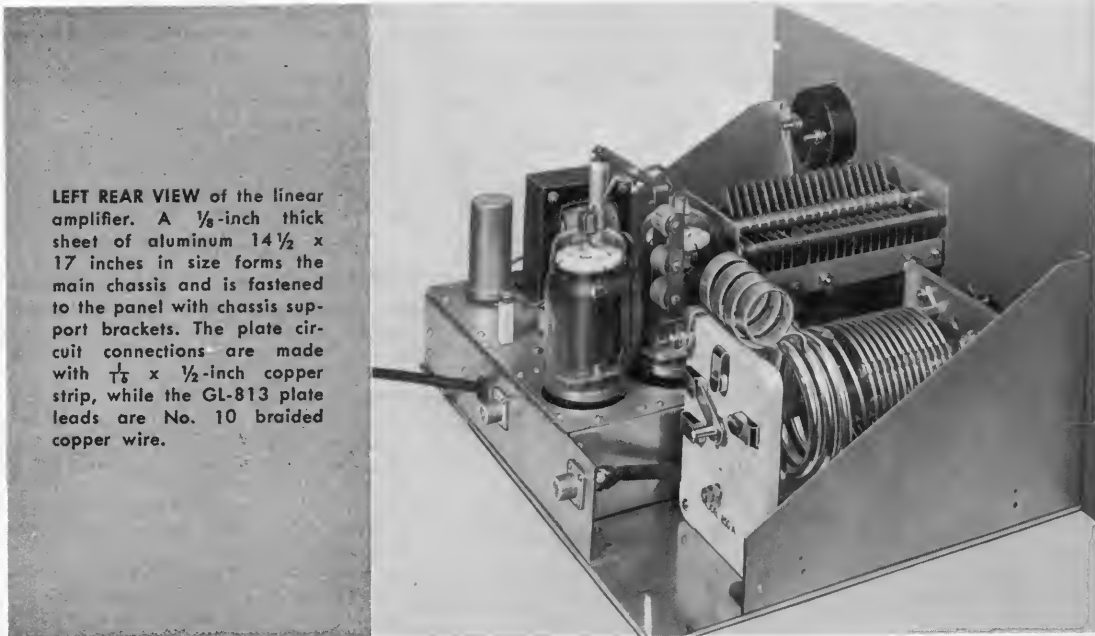

LEFT REAR VIEW of the linear amplifier. A $\frac{1}{8}$ -inch thick sheet of aluminum $14\frac{1}{2} \times 17$ inches in size forms the main chassis and is fastened to the panel with chassis support brackets. The plate circuit connections are made with $\frac{1}{16} \times \frac{1}{2}$ -inch copper strip, while the GL-813 plate leads are No. 10 braided copper wire.

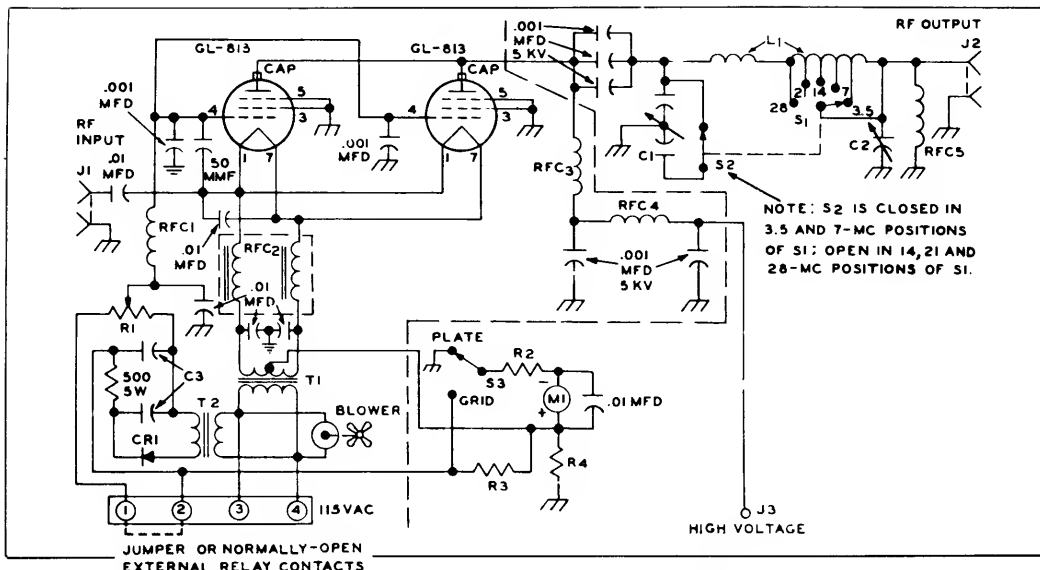

FIG. 1. SCHEMATIC DIAGRAM of the GL-813 grounded-grid linear amplifier. The five .001-mfd, 5KV fixed capacitors are of the cylindrical ceramic type with screw terminals (Centralab 8508-1000, or equivalent). All other bypass capacitances are of the disc ceramic, 500 volts working. Resistances are in ohms, with wattage ratings as specified. Resistances in the metering circuit are listed in TABLE I. No switch is shown in the 115-volt AC circuit, since it is controlled by external power switching circuits. All components to the left of the dashed line running down through the diagram are on the sub-chassis.

TABLE I — PARTS LIST

- C₁.....Split-Stator variable capacitor; front section, 28—160 mmf; rear section, 7-50 mmf; 0.125-inch air gap (Cardwell P-8359, or equivalent).
- C₂.....50—1500 mmf variable capacitor, 0.030-inch air gap (Cardwell P-8013, or equivalent).
- C₃.....2-section electrolytic capacitor, 40-mfd. 150 volts per section (Sprague TVL-2428).
- CR₁.....130-volt, 75 ma. selenium rectifier.
- J₁, J₂...Chassis type coaxial cable connectors (Amphenol 83-1H hood on J₂).
- J₃.....1 1/2 inch high standoff insulator.
- L₁.....10 uh pi-network band switching inductor (B & W 851 for up to 600 watts; B & W 850A for over 600 watts).
- M₁.....DC milliammeter, 0-1 ma., full scale.
- R₁.....500-ohm, 25 watt potentiometer.
- R₂.....Series resistance for M₁; 1200 ohms, 1 watt.

- R₃.....12 ohms, 1 watt, for 100-ma grid reading.
- R₄.....2.4 ohms, 1 watt, for 500-ma plate reading.
- RFC₁.....0.5-mh, 300-ma r.f. choke (National R-300).
- RFC₂.....15-ampere dual choke (B & W No. FC-15).
- RFC₃.....200 uh, 500-ma r.f. choke (National R-175A, or B & W No. 800).
- RFC₄, RFC₅.....1 mh, 300-ma r.f. chokes (Nat. R-300).
- S₁.....5 position single section tap switch; part of L₁ pi-network coil.
- S₂.....Special 2-position, single section switch; see FIGS. 4 and 5 for details.
- S₃.....2 position, single section tap switch.
- T₁.....10-volt, 10-ampere filament transformer.
- T₂.....115-volt, 200-ma power transformer.
- V₁, V₂...GL-813 power beam pentode tubes.

TABLE II PARTS LIST, CATHODE COUPLER

- C₁.....45—1260 mmf variable (3-section broadcast receiver variable, 15—420-mmf per section, all sections in parallel).
- C₂.....12 — 325-mmf variable, 0.024-inch air gap (Hammarlund MC-325-M).
- L₁.....4.2 uh, 17 turns, No. 16 tinned wire, 1 1/4 inches in diameter, 2 1/8 inches long, spaced 8 turns per inch, tapped 2 (21 MC, 4 (14 MC), and 10 (7 MC) turns from L₂ end of coil. (B & W No. 3018).
- L₂.....0.44 uh, 5 turns, No. 12 tinned wire, 1 inch in diameter, 1 inch long, spaced 5 turns per inch, self-supporting.
- S₁.....1 pole, 5 position tap switch, ceramic insulation (Centralab No. 2500, or equivalent).
- Shield Box....4 x 5 x 6-inch Minibox (Bud CU-3007), or 3 x 5 x 7-inch Minibox (Bud CU-3008).

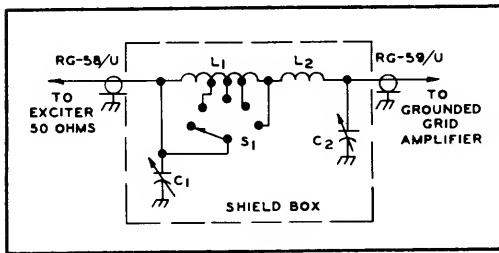

FIG. 2. SCHEMATIC DIAGRAM of an optional pi-network matching circuit. It will match the cathode circuit of the GL-813 amplifier to the 50-ohm output circuit of those exciters which otherwise might not be loaded heavy enough to fully drive the linear amplifier.

on the setting of R_1 . When no connection is made between terminals 1 and 2 on the terminal strip, the tubes are biased to cut off plate current flow. Jumpering these terminals reduces the bias to the value selected by R_1 . Leads should be run from these terminals to a switch, or relay contacts which close while transmitting.

Separate metering of current in the grid and plate circuits is accomplished by switching a single meter (M_1) across shunting resistors, R_3 and R_1 , respectively.

Only plate current is read in the PLATE position of S_2 , since the grid circuit is returned directly to the center tap on the filament transformer (T_1).

MOST EXCITERS will have a wide enough range in output impedance to match to the cathode circuit of the GL-813's (about 150 to 200 ohms, depending upon frequency). In case the exciter will only match into a 50- to 70-ohm load and will not drive the grounded grid amplifier hard enough, a pi-network matching circuit can be inserted between the exciter and amplifier.

The suggested circuit for this network is shown in Fig. 2. The parts values shown should have sufficient flexibility for most matching requirements. All components, for the matching network were housed in a 4 x 5 x 6-inch Minibox (Bud CU-3007). Lengths of coaxial cable for the input and output were cut to the proper dimensions to run to the exciter and final amplifier.

CONSTRUCTION is quite simple, due to the utilization of standard, readily available components throughout the amplifier. The main chassis is a $14\frac{1}{2}$ x 17 x $\frac{1}{8}$ -inch thick sheet of aluminum fastened with its bottom surface $\frac{1}{8}$ of an inch above the lower edge of a $10\frac{1}{2}$ x 19-inch aluminum relay rack panel. Only the pi-network components, meter and meter switch are on the main chassis, the remaining components being assembled on the 6 x 11 x $2\frac{1}{2}$ -inch sub-chassis.

The photographs and drawings illustrate the placement of the major components (Figs. 3 and 4). Either a $3\frac{1}{2}$ or $2\frac{1}{2}$ -inch meter may be used for M_1 .

The front and back plates of C_1 and C_2 are fastened to $\frac{1}{8}$ -inch thick sheet aluminum brackets 7 inches high and 4 inches wide. The shaft on which the linkage for switch S_2 is supported also runs between these plates. The parts in this linkage, and assembly details, are shown in Fig. 5. A U-shaped clip, made from spring brass or phosphor bronze, completes the connection between copper angle brackets fastened to

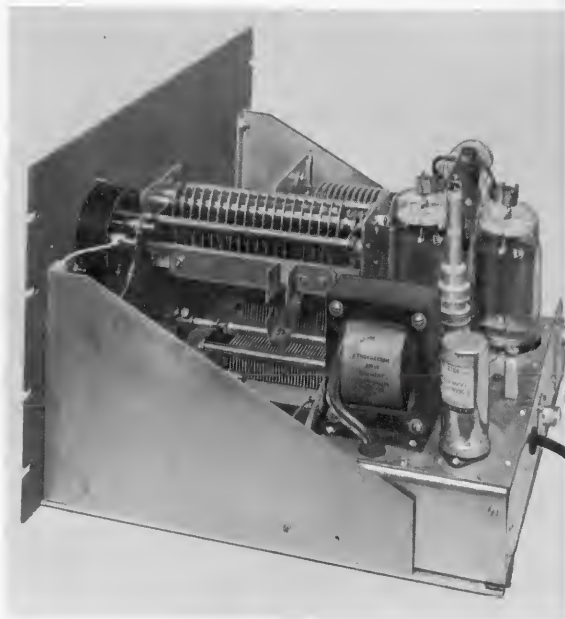

RIGHT REAR VIEW of the linear amplifier. Note how C_1 and C_2 are mounted on vertical brackets made from $\frac{1}{8}$ -inch thick sheet aluminum. The copper angle brackets and U-shaped angle bracket on C_1 is S_2 (See FIG. 5 for details). A 6 x 11 x $2\frac{1}{2}$ -inch aluminum chassis houses most of the smaller components in the amplifier.

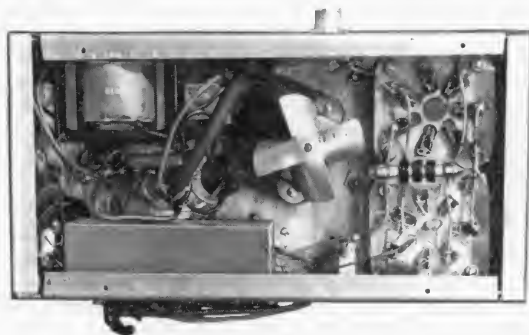
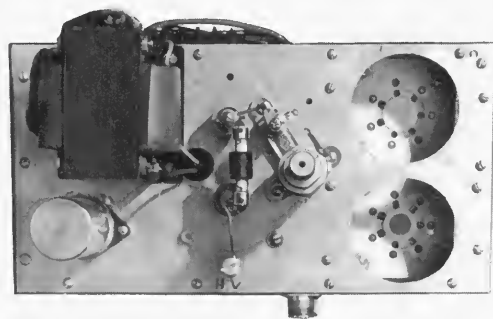

TOP AND BOTTOM VIEWS of the amplifier sub-chassis. The copper strip plate circuit connections have been removed from RFC's in the top view. Under-chassis wiring is insulated hookup wire, except for the filament leads, which are No. 12 tinned wire.

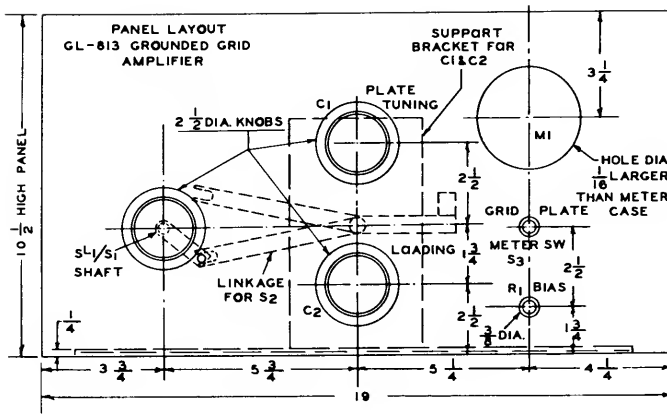

FIG. 4. PANEL LAYOUT DIAGRAM for the GL-813 linear amplifier. The linkage for S_2 pivots on the shaft located between C_1 and C_2 . Drill $\frac{3}{8}$ -inch diameter panel holes for this shaft, and the shafts on C_1 , C_2 , L_1 and the meter switch, S_3 . The aluminum chassis deck is positioned $\frac{1}{8}$ of an inch above the bottom edge of the panel.

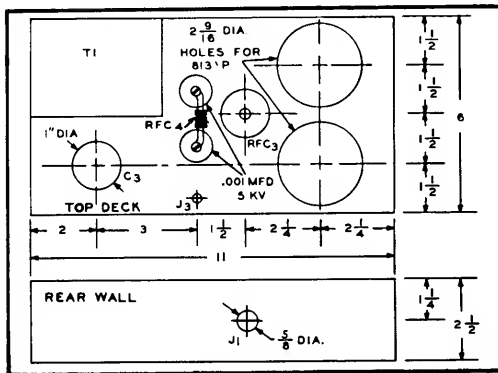

FIG. 3. LAYOUT DIAGRAM for the amplifier sub-chassis. Holes for the machine screws which secure the components in place are located from the holes on those components.

the two stator sections on C_1 , when L_1/S_1 is in the 3.5 and 7-megacycle positions. The arm on the L_1/C_1 shaft is adjusted so that it engages the forked arm, as shown in solid lines on the sketch, when S_1 is in the 7-megacycle position. Both arms should then move up so that the forked arm is in the position indicated by dotted lines when S_1 is in the 14-megacycle position.

Under-chassis wiring, except for the No. 12 tinned wire filament leads, is run with No. 18 insulated wire. The plate circuit connections were made with $1/16 \times 1/2$ -inch copper strip, as shown in the photos. A small 115-volt phonograph motor with a 3-inch diameter, 4-blade fan draws air up through holes in the aluminum base plate and out through the holes in the sub-chassis for the 813 tubes.

Once construction is finished, check the filament and bias voltage circuits before connecting the high voltage power supply to J_3 . A power supply with provision for reducing the output voltage to about one-

half or two-thirds of full voltage is recommended, especially if the full output is 2,000 volts or higher. Connect an antenna or dummy load to J_2 .

TUNEUP FOR SSB operation consists simply of applying full plate voltage and, with terminals 1 and 2 on the power strip shorted, setting R_1 for 40 milliamperes of plate current with S_3 in the PLATE position. Turn S_1 to the same band on which the driving exciter is operating and apply driving carrier power to the amplifier by injecting carrier on the SSB exciter. Adjust the exciter loading for a full-scale reading on M_1 with S_3 in the GRID position.

Turn C_2 to maximum capacitance, S_3 to the PLATE position and adjust C_1 for minimum plate current. Turn on partial high voltage and decrease the capacitance of C_2 for a plate current reading of 200 milliamperes, readjusting C_1 for minimum plate current, as necessary. Apply full plate voltage and adjust C_2 for about 400 milliamperes plate current. The grid current should read 100 milliamperes.

Switch the exciter to deliver SSB output and adjust its operation for the audio gain for normal r.f. power output. With speech, the 813 linear amplifier should swing up to about 150 milliamperes plate current; while with a steady whistle the plate current should reach 400 milliamperes. The amplifier is now tuned up.

TUNEUP FOR CW operation is similar, except that the bias voltage is adjusted initially for almost zero plate current. The exciter is adjusted to deliver 100 milliamperes of grid current in the amplifier without plate voltage. After applying partial plate voltage, load the amplifier to about 180 milliamperes plate current. With full plate voltage, the plate current should be about 350 milliamperes.

FIG. 5. DETAIL DRAWING of the linkage which actuates S_2 from the shaft driving the bandswitch (S_1) on L_1 . Three $\frac{1}{8} \times \frac{1}{2}$ -inch brass strips, soldered to brass shaft couplings, are the linkage arms. U-shaped clip-on plastic arm closes circuit between copper angle brackets on C_1 in the 3.5 and 7-megacycle positions of L_1 .

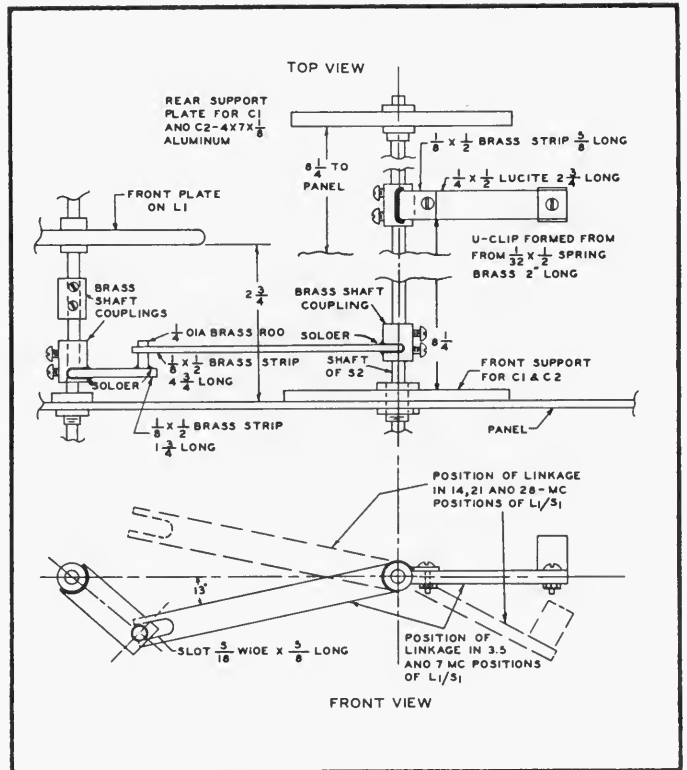

This amplifier also may be driven by a conventional amplitude modulated transmitter. The plate current is adjusted to 40 milliamperes at full plate voltage, the same as for SSB operation. Adjust the exciter for 90 to 100 milliamperes of amplifier grid current. Apply partial plate voltage and load the amplifier to about 150 milliamperes plate current. Next, apply full plate voltage and adjust for 300 milliamperes plate current.

Now, reduce the driving power from the exciter until the amplifier plate current reads 150 milliamperes. When the exciter is amplitude modulated 100 percent, the 813 amplifier plate current should rise not more than 5 percent, otherwise distortion of the output signal will result.

It's a good idea to check the operation of this amplifier with an oscilloscope during initial adjustment; and also periodically to ensure linearity of the output signal. The model amplifier constructed for this article has been operated on all bands for over a year at W2GFH without a failure for any reason. It is stable, easy to adjust and provides a really potent signal.

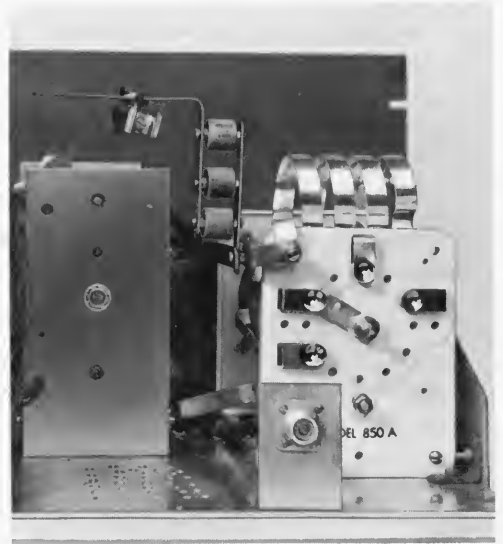

REAR VIEW of the amplifier plate circuit. Sub-chassis has been removed to show the holes in the aluminum plate through which cooling air is drawn into the chassis by the fan, and exhausted up through the chassis holes for the 6L-813 tubes.

Additional Information on G-G Linear

All changes listed below have been made in this reprint, but persons who have the original printing of the November-December, 1959 (Vol. 14, No. 6) issue of G-E HAM NEWS should note these changes if they wish to construct this amplifier.

CORRECTIONS:

1. There is an error in the plate current metering circuit in the schematic diagram, Fig. 1, on page 4. The contact on the meter switch, S₃, labeled "PLATE", should be connected to ground, and not connected to the center tap of the filament transformer, T₁. The corrected circuit is shown in Fig. 1 on the reverse side of this bulletin. The circuit as originally shown shorts out the meter in the "PLATE" position, resulting in practically no meter reading.
2. The plate spacing of C₁, the 15--300-mmf variable capacitor in the pi-network cathode input coupler diagram, Fig. 2, on page 4, should be 0.0245 inches, not 0.224 inches, as given in TABLE II - PARTS LIST, CATHODE COUPLER.
3. WATTAGE RATING FOR POTENTIOMETER R₁ - This rating, given as 2 watts, actually should be 25 watts. The low resistance of this potentiometer across the bias voltage supply stabilizes the bias, thus a high-wattage potentiometer is required at this point.
4. CAPACITANCES IN PI-NETWORK CATHODE COUPLER - The listings for capaci-

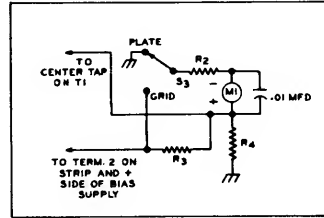

5. tors C₁ and C₂ in the pi-network cathode coupler (Fig. 2 on page 4) were reversed. C₁ should be the 3-section broadcast receiver capacitor; and, C₂ should be the 12--325-mmf capacitor to match into the cathodes of the 813 tubes.
5. The size of the main chassis plate, given as 13 inches deep x 17 inches wide, should be 14 1/2 inches deep, in order to accommodate both the capacitor mounting, which occupies 8 1/2 inches of depth, and the 6-inch depth of the subchassis on which the tubes are mounted. This dimension was given in the Left Rear View on page 3, and in the text on page 5.

COMMENTS ON COMPONENTS AND SUGGESTED SUBSTITUTIONS

Here is additional information on components used in the original model, and suggested substitutions for those components which are suitable both mechanically and electrically.

COMMENTS ON COMPONENTS:

1. THE BARKER & WILLIAMSON components used in the amplifier (L₁/S₁, RFC₂, and the plate RF choke, RFC₃) can be obtained from those radio parts distributors which specialize in amateur type components and equipment. These distributors will order
2. CONTROL KNOBS - B & W type 901 turned aluminum knobs (1-7/8 inches in diameter) were used on the bandswitch, plate tuning and plate loading controls. B & W type 903 knobs (11/16 inches in diameter) were used on the meter switch and bias control.
3. PLATE CIRCUIT RF CHOKE - A B & W type 800 RF choke is recommended for RFC₃, rather than the National R-175A choke shown in the model amplifier. The R-175A choke may have VHF resonances which could cause the choke to burn out.

these parts from B & W if they do not have them in stock.

4. CAPACITOR C_1 - This capacitor is a Cardwell type P-8359, no P-8060, as specified in TABLE I PARTS LIST of the original printing of this issue.
5. AVAILABILITY OF CARDWELL CAPACITORS - Some persons have reported difficulty in obtaining the Cardwell type P-8359 (C_1 about \$33.00 amateur net) and P-8013 (C_2 - \$19.50 amateur net) variable capacitors. We have been advised that these capacitors are currently available through electronic parts distributors. If these capacitors are not in stock, the distributor can order from the Cardwell Condenser Corporation, 80 East Montauk Highway, Lindenhurst, Long Island, New York.
6. SUBSTITUTE FOR C_1 - A conventional split-stator variable capacitor of suitable capacitance and voltage rating can be substituted for the Cardwell unit. The Johnson type 100ED45, Cat. No. 154-3, having 15--100-mmf per section, and a 0.125-inch air gap, is recommended. Install the switch between the stators of C_1 on the studs supporting the stator plates at the middle of the capacitor. Change the linkage running from S_1 to the shorting bracket on S_2 to suit the parts layout of your particular amplifier.

7. SUBSTITUTE FOR C_2 - Although the high maximum capacitance range of the Cardwell P-8013 capacitor (150-1500-mmf) makes it ideal for pi-network output circuits, a smaller variable capacitor and a tap switch to add fixed mica capacitors across the pi-network output, can be substituted. The circuit shown in the COMPACT TRIODE KILOWATT (See G-E HAM NEWS, September-October, 1959; Fig. 1, page 4, for details) is suitable. This circuit is repeated at right for your convenience.

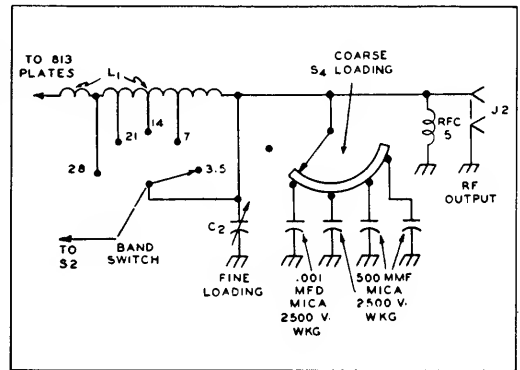

8. POWER RATING OF TANK CIRCUIT - If 2,000 volts or less will be run on the plates of the GL-813's, a capacitor for C_1 with 0.100-inch air gap will be suitable. The 0.125-inch air gap specified is suitable for up 3,500 plate volts. The B & W model 851 pi-network circuit is actually suitable for average power inputs of 800 watts in SSB service, as tests on the model amplifier have indicated.
9. RATING OF RFC₄ - Although the rating of the r.f. choke in the plate voltage lead is only 300 milliamperes, the amplifier plate current swings up to 400 milliamperes only on peaks, thus the 300-milliamperer f. choke is sufficient for the AVERAGE plate current drain.
10. OTHER PI-NETWORK INDUCTORS - The air-dux type 195-1 (500 watts) and 195-2 (1000 watts) inductors also may be used in this amplifier. A number of readers have inquired about this. A well-insulated tap switch capable of carrying 10 amperes of r.f. current is needed for the bandswitch, which is not a part of the air-dux inductors. Home-wound coils, and pi-network coils made up from ready-wound inductor stock, with a 28-megacycle coil wound from copper strip, also can be used for L_1 . The same inductance values shown in TABLE 3 - PI-NETWORK CHART FOR 813 AMPLIFIER, should be used to design home-wound coils, or to prune ready-wound inductor stock.

11. PLATE TANK CIRCUIT CONSTANTS - The plate circuit pi-network in the GL-813 grounded-grid amplifier was designed for a 2,500-ohm plate load, working into a 50-ohm antenna load. A tabulation of the inductance and capacitance values required in the circuit for bands from 3.5 to 28 megacycles is given in TABLE 3. Note that the number of active turns in the circuit on each band is given for air-dux type 195-1 and 195-2 coils. The turns figures do not include the strip-wound 28-megacycle coils, and are given from where the strip coil joins the coil wound with wire. The inductance values DO include the strip inductor, which is 0.4 microhenries.

TABLE 3

TABLE 3 - PI-NETWORK CHART FOR 813 AMPLIFIER					
LOAD IMPEDANCE (ohms)	BAND (MC)	C ₁ (mmf)	L ₁ (uh)	ACTIVE TURNS (see text)	C ₂ (mmf)
2,500	3.5	210	10.5	15	1,500
2,500	7	105	5.2	8.5	760
2,500	14	52	2.6	5	380
2,500	21	35	2.6	3	250
2,500	28	26	1.28	1	190

12. HEAVY-DUTY BANDSWITCH REQUIRED FOR S₁ - The G-E HAM NEWS lab has used Ohmite type 111-5 5-position, single section rotary tap switches with air-dux coils in other amplifiers and has found them capable of holding up in r.f. bandswitching service. They are rated at 10 amperes in 115-volt, 60 cycle AC switching service, and have a rotor contact insulated from the shaft for about 600 volts AC. However, we recommend mounting the switch on an insulated bracket, and using an insulated coupling on the shaft for r.f. service, especially in circuits having a plate voltage of 2000 or more.
13. INSTABILITY AT 28 MEGACYCLES - If instability is encountered in this amplifier at 28 megacycles, try connecting a 50-mmf mica capacitor between the control grid and one side of the filament (pin 4 to pin 1) on one 813 tube socket. This should help stabilize the amplifier at this frequency.
14. OTHER TUBE TYPES IN THE GL-813 GROUNDED-GRID CIRCUIT - Other tetrode and pentode transmitting tubes also may be used in this circuit. Of course, the cathode input impedance and plate load impedance will differ from the values given for this amplifier. The pi-network cathode coupler circuit, shown on page 4 (Fig. 2) of the November-December, 1959 issue, usually will provide a close impedance match between the exciter and the linear amplifier. For tubes operating at higher plate voltages and lower currents (higher plate load impedance) than the 813, less capacitance is needed in C₁ and C₂, and L₁ will have higher inductance. For tubes operating at lower plate voltages and higher currents (lower plate load impedance), more capacitance will be needed in C₁ and C₂, and less inductance needed in L₁. Excellent pi-network data can be found on Tele-Hints sheet No. 8 for air-dux coils. This sheet is published by Illumitronic Engineering, Sunnyvale, California.

A PREVIEW OF '63 MODEL --

PHOTO AT RIGHT shows preliminary model of repackaged parallel-GL-813 amplifier being readied for publication in G-E HAM NEWS late in 1962. Design is suited for either grounded-cathode pentode, or grounded-grid triode operation of GL-813's. Cabinet is made from a 13 x 17 x 3-inch, and a 13 x 17 x 4-inch chassis, for total height of only 7 inches.

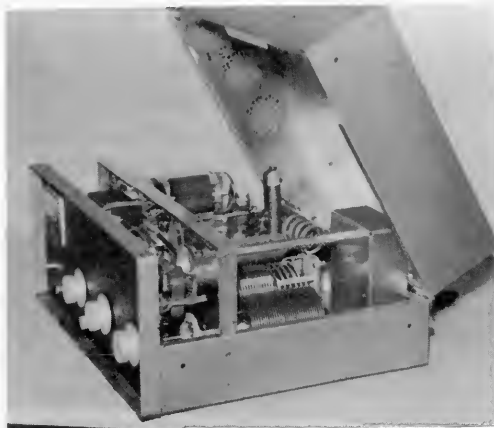

NOTE: The disclosure of any information or arrangements herein conveys no license under any patents of General Electric Company or others. In the absence of an express written agreement to the contrary, the General Electric Company assumes no liability for patent infringement (or any other liability) arising from the use of such information by others.

Operation of GL-813 as SSB Linear Amplifier

	Single Tube		Two Tubes (Parallel)			
	AB ₁	AB ₂	AB ₁	AB ₁	AB ₁	AB ₂
Plate voltage	1250 v	1500 v	1250 v	1500 v	2000 v	2500 v
Control grid voltage	-80 v	-90 v	-80 v	-90 v	-90 v	-95 v
Screen grid voltage ¹	750 v	750 v	750 v	750 v	750 v	750 v
Peak grid to grid ac voltage	80 v	95 v	160 v	190 v	212 v	234 v
Static plate current	45 ma	40 ma	90 ma	80 ma	90 ma	36 ma
Max. Sig. Plate current (sine wave input)	165 ma	158 ma	330 ma	315 ma	330 ma	360 ma
Static #2 grid current	3 ma	1.5 ma	6 ma	3 ma	4 ma	1.2 ma
Max. Sig. #2 grid current (sine wave input)	25 ma	29 ma	50 ma	58 ma	60 ma	56 ma
Max. Sig. driving power ²	0 w	0.1 w	0 w	0.2 w	0.2 w	0.36 w
Control grid current ²	0 ma	0 ma	0 ma	0 ma	0 ma	0.4 ma
RMS power output	110 w	160 w	220 w	320 w	430 w	650 w
RMS power input	206 w	254 w	412 w	508 w	660 w	840 w
Load impedance, ohms	3300	5000	1900	2300	3000	3400 ohms

¹ In pentode-connected grounded cathode circuits. In grounded-grid No.1 service, screen grids should be operated at 0 volts DC.

² In pentode-connected grounded cathode circuits. In grounded-grid No.1 service, driving power will run from 50 to 90 watts, and grid current from 70 to 100 milliamperes, depending on plate voltage and operating frequency.

Regulation of control grid and screen voltages should be within 5 percent or better for best linearity. A string of five OD3/VR-150 voltage regulator tubes in series will provide a suitable source of regulated screen voltage. A good power supply also may be used. Never apply screen voltage without plate voltage.

600-WATT ALL-BAND AMPLIFIER FOR CW, AM OR SSB LINEAR SERVICE

Featuring — Push-Pull GL-813's to Ease Your Steps to High Power

From November-December, 1954



There's no "easy" way to power — but this amplifier, designed and described by W2GYV, employs tested techniques and standard components to make the road to power as smooth as possible.

—*Lighthouse Larry*

GENERAL DESCRIPTION

Here's a husky all-band final that does not utilize any new or trick circuits or any substantially different mechanical layout. It will be recognized from the circuit diagram and photographs as a conventional push-pull tetrode amplifier constructed in a straightforward manner. It illustrates the use of modern components and practical design.

In this complicated age, there is much to be said for an occasional attempt at simplification; and those seeking a respectable amount of power may find this amplifier fills their needs without emptying their pocketbooks or fraying their nerves during construction and testing.

The amplifier employs a pair of GL-813 tubes in a neutralized push-pull circuit. A multiband grid tank allows the input circuits to be permanently shielded and simplifies band-changing. The plate circuit uses standard plug-in coils which are easily accessible for band changing through the shielded and RF weather-stripped panel door.

No metering is provided in the amplifier itself. The incorporation of meters would make shielding and circuit isolation more difficult. It is much simpler and forthright to install grid, screen and plate current meters in a standard three-hole panel mounted elsewhere in the rack and connected in the power leads going from the amplifier after all RF has been filtered from them.

A regulated bias supply is included in the unit since with the low grid currents encountered it can be a simple affair and is something that would probably have to be built up in any event.

All controls, including input and output coupling, are conveniently located on the front panel. Coaxial connectors are used for the RF input and output and HV plug connectors for plate and screen leads. The grid meter and interlock circuit connections are made with two-contact microphone plugs mounted under a small shield on the rear of the chassis—thus making it a short and easy operation to disconnect all leads and remove the amplifier from its rack. The AC input—for bias and filament power—is through a cord and plug leading to the control unit shown in G-E HAM NEWS of March-April, 1954. (Volume 9, No. 2).

CIRCUIT DETAILS

The only part of the circuit which may be out of the ordinary is the use of a four-section variable capacitor, C_{12} , in the plate tank. This capacitor is adapted from a standard unit as explained under the constructional details and allows optimum L/C ratio to be achieved on all bands. It also makes tuning less critical on the three highest bands. The proper sections of the capacitor are selected automatically by jumpers on the coils between pins 1 and 2 and 7 and 8.

The plate coils are standard 500-watt units and although the amplifier has been run for extended periods at inputs of over 600 watts no undue heating of the coils was experienced. Jacks 3 and 6 on the coil socket were not used in this design.

The output is through a shielded link as specified. These links are available in 1, 2, and 3 turns. Generally, a 1-turn link is considered satisfactory at 10 meters, a 2-turn link at 15 and 20 meters, and a 3-turn link for 40 and 80. However, during tests, a 2-turn link was found satisfactory for all bands when working into a 52-ohm coaxial line. Experimentation is recom-

mended here as each antenna system may be slightly different. What works at one installation may not work well at another, even though the same general system is used, since one line may have a different standing wave ratio than the other. At any rate, link coupling of this sort is probably the easiest of all coupling devices to adjust.

The vacuum capacitors C_6 and C_{11} are for the purpose of providing a short low impedance path for the higher harmonics which might cause TVI. It should be pointed out that they are not necessary to the normal satisfactory operation of the amplifier and may be omitted if TVI is not a problem.

Don't be misled, however, into thinking that these capacitors themselves will be a complete cure for all TVI. They are an aid in stubborn cases and you may well want to try the amplifier before installing them. However, the vacuum capacitors are part of the total plate tank capacitance and the coil modifications given in the coil table are based on their use. Leaving them out may not necessitate the coil modifications listed under "Coil Data."

The neutralizing capacitors, C_2 and C_5 , were found necessary to completely stabilize the amplifier. All normal checks failed to reveal the need for neutralizing; but on checking the amplifier for stability by operating it at zero bias, no RF drive, and with plate and screen voltages adjusted to give rated static plate and screen dissipation, it was found that a weak oscillation would occur when both grid and plate were tuned to the same frequency. The neutralizing wires were then adjusted until this did not occur. This should be done with the 10 meter coils in place and will then hold for all-band operation. The neutralizing wires are made from No. 14 copper wire and are brought through the chassis approximately one inch from the tubes. Small ceramic feed-through insulators were used for this purpose. Start off with wires reaching to the tops of the tube anodes and adjust them by clipping off $\frac{1}{2}$ inch at a time until a length is found which will give complete neutralization. Fine adjustment is made by changing the spacing between wires and tubes by means of an insulated rod through the $\frac{1}{4}$ -inch holes in the back of the shield.

The bias supply is conventional. It utilizes a GL-OA3/VR75 tube for regulation and so furnishes 75 volts of fixed bias. The remaining bias is developed across R_1 by the flow of grid current. This resistor may be seen in the photographs on top of the bias supply sub-chassis. The remaining resistors and selenium rectifier are mounted under this sub-chassis. The 75 volts is more than sufficient for plate current cutoff, allowing the driver to be keyed for CW work provided the screen is supplied from a fixed supply or from a voltage divider from the HV plate supply. Do not attempt CW operation if the screen is supplied through a dropping resistor.

Liberal use has been made of by-pass capacitors and RF chokes. All of these precautions make for stable, trouble-free operation and are well worth their cost.

An interlock switch S_1 , is provided to protect the absent-minded when changing coils. It should be connected in the power supply in such a manner that the primary voltage to the plate supply is removed when the door is opened. The micro-switch used is a SPDT switch and should be connected so that the switch opens the circuit when the door is open. In addition, provision should be made for shorting the high voltage

lead to discharge the filter capacitors before changing coils. Make up a shorting stick NOW. AND USE IT! A fellow isn't even allowed one mistake at these voltages!

MECHANICAL DETAILS

Much thought and time was given trying to evolve some novel and suitable mechanical layout—something that would be eye-catching and efficient. In fact, the whole project was delayed several months because of this. Several unique ideas were dreamed up but discarded because they were too expensive, too difficult to construct without metal-working facilities or else they just shouted over-design.

The old standby of chassis and panel construction proved to be not only the easiest to handle with the usual facilities but also promised to fit into most modern station layouts.

The biggest problem (and it was small compared to some of the layouts that were considered) was that of getting the plate tank capacitor and link controls out to the front panel. The solution was found with standard components. The capacitor is driven with a right-angle drive unit, two universal joints, and some $\frac{1}{4}$ -inch diameter shaft. Panel bushings are used wherever the shaft goes through the chassis or panel. The link control required only two flexible shafts. The arrangement should be evident by inspecting the photographs.

The parts layout is also clearly shown and no detailed drawings are given. The multiband tank is mounted on spacers so the tuning and link shafts are centered on the lower section of the front panel.

The bias supply is built on a separate sub-chassis easily shaped and mounted as shown and there is nothing critical about the placement of parts. The sub-chassis is fastened to the side of the main chassis by two screws in front and by the feed-through capacitors, C_{20} and C_{22} on the rear apron of the main

chassis. The AC line filter capacitors, C_{25} and C_{27} are mounted on the bias chassis and project through the main chassis in close-fitting holes.

Ventilation is provided through the panel door and the vent holes over each tube. Natural draft provides sufficient air to prevent overheating of the tubes.

CONSTRUCTIONAL DETAILS

All components are mounted as shown in the photographs on a 13 x 17 x 4-inch aluminum chassis. Aluminum is recommended rather than steel as it is both easier to work and will not rust in damp locations. Even a plated steel chassis will rust around the drilled holes. No special precautions are necessary in the layout that cannot be observed in the illustrations.

The front panel calls for special attention if satisfactory shielding is to be achieved. The panel used is a $12\frac{1}{4}$ -inch Par-Metal Grille Door Panel (Cat. No. G-682). In making the panel RF-tight, the paint was removed by soaking the entire panel in paint remover and then rinsing well. After this was done, the panel was copper-plated. While plating is not absolutely essential it will result in a more permanent shielding job.

After plating, a piece of standard bronze insect screen was carefully soldered to the inside of the grill door.

The next operation was to install the RF weather stripping. The particular material used was made by Instrument Specialties Co., Little Falls, N. J. (Cat. No. 97-112-H). This material is $\frac{1}{8}$ -inch-wide beryllium copper strip with $\frac{1}{8}$ -inch wide fingers, $5\frac{1}{2}$ fingers per inch. Similar stripping of other manufacture could also be used satisfactorily. This strip is held to the panel by a $\frac{1}{2}$ x $\frac{1}{2}$ -inch aluminum angle running completely around the sides and top of the door opening and secured to the panel with brass machine screws.

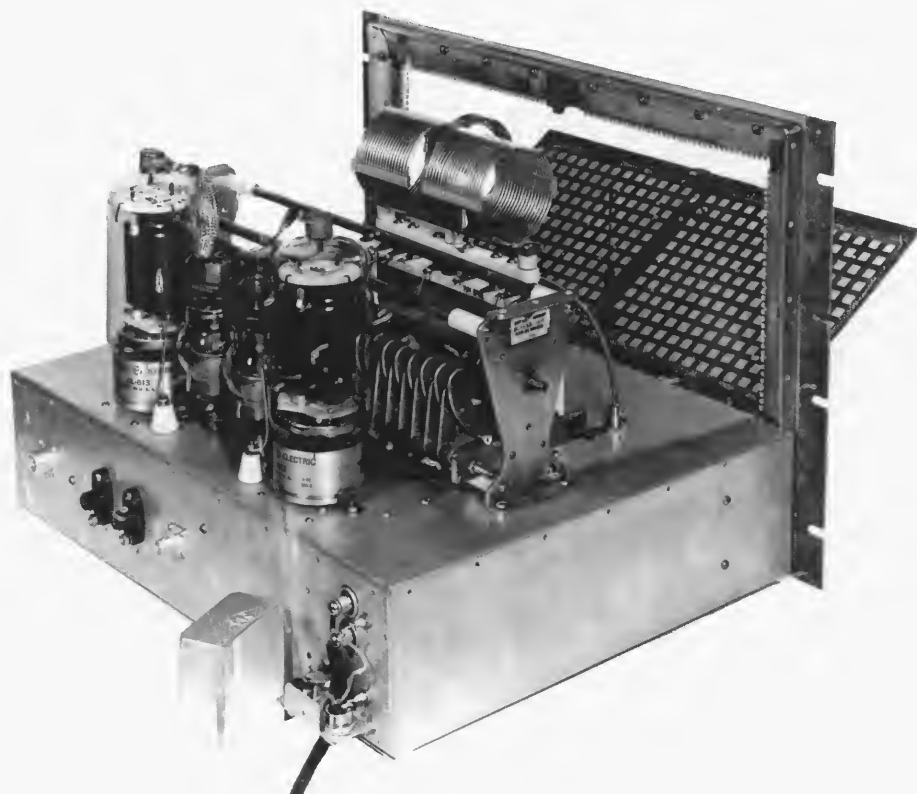

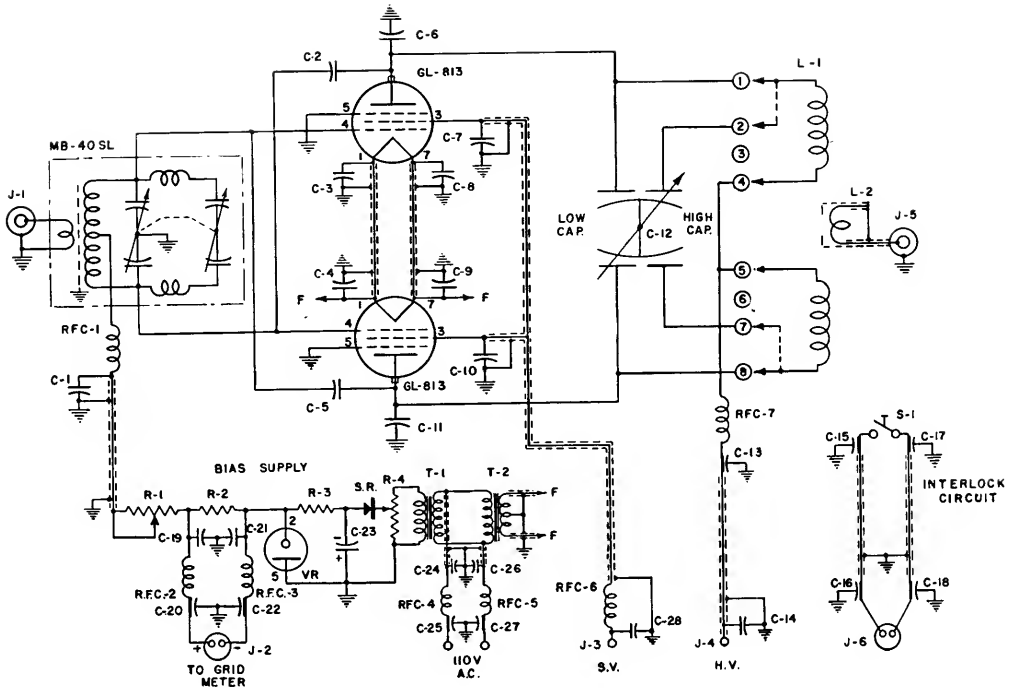

Parts List and Coil Winding Table

C₁, C₃, C₄, C₈, C₉—.002 mfd. disc ceramic (Centralab DD-202)
C₂, C₅—Neutralizing wires (see text)
C₆, C₁₁—12 mmf. vacuum capacitor (GL-1L21 or 1L25)
C₁₂—100 mmf. per section, split stator. (Bud 1633A modified as described in text.)
C₇, C₁₀, C₂₈—.0005 mfd., 1000-volt mica (Sprague 3CFM-35)
C₁₃—.002 mfd., 5 KV (Sprague Hypass 47P16)
C₁₄—500 mmf., 20 KV ceramic (Sprague 20DK-T5)
C₁₅, C₁₆, C₁₇, C₁₈, C₂₀, C₂₂—.001 mfd., 500-volt ceramic feed-thru (Centralab No. FT-1000)
C₁₉, C₂₁, C₂₄, C₂₆—.001 mfd., disc ceramic (Centralab DD-102)
C₂₃—10 mfd., 450 VDC electrolytic (Sprague EL-1)
C₂₅, C₂₇—.01 mfd., 250 VAC (Sprague Hypass 48P9)
R₁—5000-ohm, 25-watt, adjustable wire-wound
R₂—100-ohm, 2-watt
R₃—10,000-ohm, 5-watt, wire-wound
R₄—25,000-ohm, 25-watt, adjustable, wire-wound
T₁—Thardarson T-22R12, 117/120, 6.3-volt, selenium rectifier

power transformer. (6.3-volt winding not used.)
T₂—Thardarson T-21F19, 10-volt, 12-amp. filament transformer
SR—100 ma., 135-volt selenium rectifier (GE-6RS5GH1A)
MB-40SL—National multiband tank unit
L₁—B & W type TVH, 500-watt coils.
L₂—B & W shielded link No. 3282.
J₁—UG—90/U, BNC connector
J₂, J₆—Amphenol 80-PC2F locknut receptacles.
J₃, J₄—Millen 37001 HV connector
J₅—SO-239, UHF connector
S₁—Micraswitch (BZ-RQ1)
RFC₁—2.5 mh RF choke
RFC₂, RFC₃, RFC₆—Ohmite Z-50
RFC₄, RFC₅—25 turns, ¼" diameter, No. 16 en., close wound, self-supporting.
RFC₇—4 mh, 750 ma. (Miller No. 4336)
VR—GL-OA3/YR75 voltage regulator tube

PLATE TANK COIL DATA

All coils B & W TVH, 2½-inch inside diameter
 80—38 t. No. 14 spaced to 5¼-inch length with ¾-inch separation in center. (Jumpers between pins 1 & 2 and 7 & 8.)
 40—24 t.; other specifications same as 80-meter coil, including jumpers.
 20—12 t. No. 12 spaced to 4¾-inch length with ¾-inch separation in center. (TVH with one turn removed from each end.)

15—8 t. of ⅛-inch d. wire or tubing spaced to 6-inch length with ¾-inch separation in center. (TVH with one turn removed from each end.)
 10—4 t. of ⅛-inch d. wire or tubing spaced to 3-inch length with ¾-inch separation in center. (TVH with two turns removed from each end.)

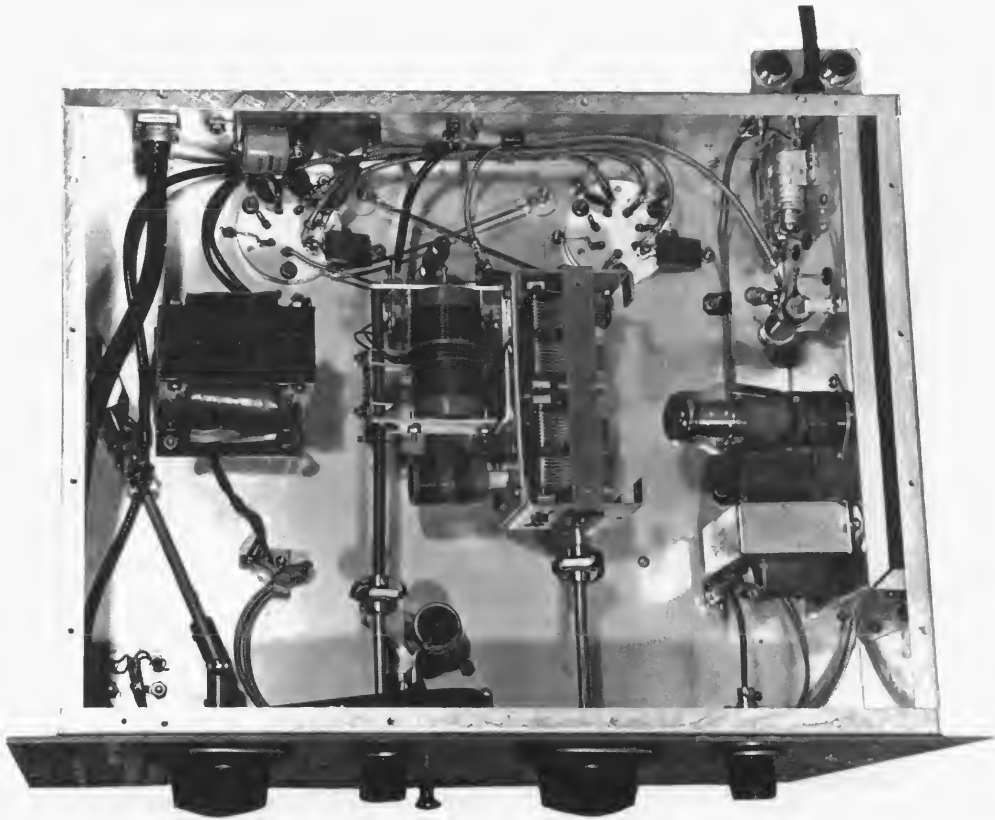

Bottom view clearly shows placement of components. Note RG-8/U output link runs from output connector at top right of picture around upper edge and down to similar connector at left center. Bias supply components mounted on sub-chassis. In close-up picture (below) note RFC₇, mounted underneath final tank coil. This view also shows lugs added to tank tuning capacitor when modified as described in text.

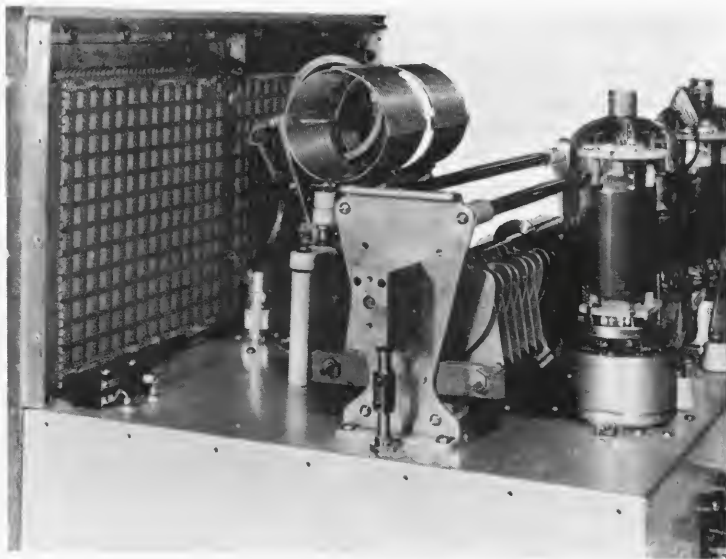

This angle serves the dual purpose of providing a support for the cover as well as holding down the RF weather strip.

The chassis cover is made of 1/16-inch soft aluminum, bent by clamping it over the edge of a work bench using a piece of angle iron and two "C" clamps. Lips should be bent on the edges of the back to be bolted to the sides after all bending is completed. Self-tapping screws are used to hold things together here. The ventilation holes over the tubes should be drilled before the cover is bent. (Those who notice the photographs show a plate with vent holes bolted over two large holes in the top of the shield are asked to excuse a mistake made during construction. It was intended to drill a fancy design in the top for vent purposes but the drill unfortunately slipped. Again, we recommend simplicity!)

The chassis for the bias supply was conveniently formed over a short length of 2 x 4-inch lumber. This made it exactly the right width and also furnished a back-up block for drilling operations.

Do not skimp on the number of screws used in holding the shielding together. Any gaps in the joints provide a chance for RF to leak out. The bottom plate should be fastened with several self-tapping screws along each edge rather than with the screws in each corner as provided by the manufacturer.

Two 1/4-inch diameter holes should be drilled in the back opposite the neutralizing wires for later use in adjusting the neutralization.

After the construction and wiring is complete, the outside of the panel and the cover can be painted with a hard machinery enamel.

After all mechanical details are complete, the amplifier may be wired. Shielded wire was used exclusively—RG-58/U coax for the high voltage leads and ordinary single-conductor shielded wire for the low voltage wiring. The filament leads should be No. 14 shielded wire. Ground the shielding at both ends of the leads and wherever else it may be convenient.

Lead lengths on all by-pass condensers should be kept as short as possible.

The Sprague Hy-Pass capacitor used for C_{13} was considered desirable as it allowed the return to be made to the under side of the chassis, providing a short and direct path to the cathode. If it were made to the top of the chassis, the RF would have to find its way through the chassis in order to complete the circuit to the cathodes and could well result in instability due to incomplete plate by-passing. This capacitor is mounted through a snug-fitting hole and held in place by a small brass angle on the underside of the chassis. This angle also provides the ground connection for the capacitor.

The interlock circuit and grid current meter terminals are protected by an aluminum cover cut from a coil shield can.

MODIFYING THE PLATE CAPACITOR

The modification of the plate tuning capacitor requires some careful workmanship. The capacitor, before modification, consisted of two sections—each with ten stator plates. The seventh stator plate from each end was removed by sawing through the support rods 1/4-inch from each side of the plates. Next, four pieces of 1/2-inch diameter insulating rod (mycalex was used) were cut to fit exactly the gaps left between the sixth to eighth plates. The ends of these insulating spacers were drilled and tapped to take the threads of the stator support rods. No changes were made in the

rotor assembly. This left a capacitor having four separate stator sections—the two inside sections consisting of three plates each, and the two outside sections six plates each. Suitable heavy solder lugs, visible in the photographs, are inserted between both ends of the insulated rod and adjacent plates to allow connections to be made to the stators.

The shielded link is plugged into an SO-239 coaxial connector mounted on top of the chassis, to allow the link line to feed through the chassis and connect to the output connector on the rear apron. Both connectors are shielded where the coaxial jumper connects by means of standard receptacle hoods designed for this purpose. The shielded link is supplied with a pair of shielded leads. To use the link with coaxial circuitry, it is necessary to connect one inner conductor to the shielding braid right at the link, leaving a single shielded lead for connection (see circuit diagram).

The bases of the GL-813's are grounded to the chassis by small metal clips from a socket for a GL-4-250A. Since these may not be readily available, a suitable clip can be made from spring brass or bronze.

TUNING UP

The first step in getting the amplifier into operation is to set the bias voltage. This can best be done before the supply is fastened in place. After checking to be sure all wiring is correct, apply power and adjust R_4 for a current of 5 milliamperes through the VR tube. The easiest way to check this is to measure the voltage drop across the 10,000-ohm series resistor, R_3 , using a VTVM or high resistance DC voltmeter. This will be 50 volts DC for 5 milliamperes of current. Bias resistor R_1 should be set at 3500 ohms for a plate supply voltage of 1600 volts and 3000 ohms for 2000 volts. If only CW operation is contemplated, set R_1 at 2500 ohms. The higher values will be satisfactory for both phone and CW work but it is recommended that slightly lower grid drive be used on CW, approximately 7 milliamperes per tube. It is good practice to use the minimum amount of drive for full output under all conditions as an aid to keeping down harmonic generation.

Neutralizing should be accomplished as explained under "Circuit Details" *only* if fully adjustable plate and screen voltages are available. Otherwise it should be done in the conventional manner by coupling a sensitive RF indicator to the plate tank and adjusting the neutralizing wires for minimum output.

It is recommended that all wiring to the power supplies and meters be shielded and the shields grounded at both ends.

Several methods of obtaining screen voltage are possible. A series dropping resistor from the plate supply may be used for phone work only or a voltage divider across the plate supply could be used for CW. The method used with this final was a fixed supply of 350 to 400 volts with choke output consisting of a standard 10-henry filter choke. This method allows the screens to modulate themselves and has the added advantage of not requiring any changes for CW work. When going from phone to CW it is only necessary to turn off the modulator supply and short the secondary of the modulation transformer.

This amplifier has proved itself in all respects. It is easy to build; provides a good quality signal; and offers sufficient power to compete with the best.

CONSTRUCTION NOTES FOR THE 600-WATT ALL-BAND AMPLIFIER

Additional construction information has been compiled about this amplifier, and to suggest alternate plate tank capacitors for the Bud No. 163A originally specified.

The National MB-40 grid tank circuit was mounted on small tubular metal spacers slipped over the machine screws that run between the underside of the chassis and the side bracket on the MB-40 capacitor. The other side bracket appears in the bottom view photograph.

RFC₄ and RFC₅ are located underneath the small sub-chassis and do not show in the pictures. One end of each of these chokes attaches to the ends of the feed-through capacitors which you can see clamped on top of this sub-chassis. The other ends of these chokes run to short standoff insulators underneath the sub-chassis. Also attached to these insulators are C₂₄, C₂₆ and the leads from T₁ and T₂.

RFC₇ is a Miller No. 4536, not 4336, as the parts list specified. Other RF chokes with similar ratings, such as the National R-152 and R-154; Bud CH-569; Johnson 102-754; or ICA 267 and 278, may be substituted, since the RF choke does not work very hard in this particular circuit. The choke is mounted directly beneath the amplifier plate tank coil, L₁. Incidentally, the jack bar for the tank coil is mounted on 3/4-inch diameter x 2-inch long steatite pillar insulators.

Two Millen right angle drive units, No. 10012, and a universal joint, Millen No. 39005, are required to drive the plate tank capacitor shaft from the front panel. The drive is attached onto the capacitor shaft by taking off the cover, loosening the set screw that holds the gear on one extension shaft, and removing this shaft. The capacitor shaft is then inserted into this gear, the set screw is again tightened, and the cover is replaced. The body of the right-angle drive is then fastened to the capacitor frame.

A short extension shaft is coupled to the right-angle drive, then run through a panel bearing to the second right-angle drive, located beneath the chassis between the filament transformer and the chassis side wall. This drive is fastened to the chassis at an angle, as shown in the bottom view, and another extension shaft runs to the universal joint near the panel. A shaft and panel bearing assembly mounted on the panel runs to the universal joint. This assembly work should be carefully done to insure a smooth running drive with no backlash.

Since the Mycalex insulation specified for the insulating bushings that must be added to the Bud plate tank capacitor, C₁₂, may not be readily available, 3/4-inch diameter polystyrene rod may be substituted. The overall length of this insulating spacer should be 0.953 inches. The holes for the stator plate rods should be carefully drilled and tapped, because the polystyrene is easily overheated and may clog the drill or even crack. A 10-32 tap size is required for the rods on the Bud 1633A capacitor.

Another good insulated spacer for the Bud capacitor may be made from a Centralab No. X-21 steatite pillar insulator. This pillar is 3/4 of an inch in diameter, 1 inch long and has 10-32 threaded holes at each end. If a small workshop grinder is available, the ends can be ground off to make the overall length 0.953 inches. Care should be taken to make the ends square with the sides of the pillar.

If the 1-inch long pillar cannot easily be shortened, a Centralab No. X-20 steatite pillar, 3/4 of an inch in diameter, 3/4 of an inch long, also with a 10-32 threaded holes, can be used with spacer washers. These washers should total 0.203 inches in thickness within a few thousandths of an inch. Otherwise, the both stator sections cannot be properly centered with respect to the rotor plates.

A Johnson Cat. 153-510, 150DD70 2-section variable capacitor can be substituted for the Bud capacitor. It had 10 stator plates per section, each of which was split to form two stators of three and six plates. One plate in each stator is eliminated when the insulator is inserted. The Johnson capacitor has 11 stator plates per section, and should be split between the third and fourth stator plates from the center of the capacitor. This leaves small stator sections having three and seven plates, respectively.

Since this capacitor also has 10-32 threaded rods holding the stator plates together, the same type of home-made bushing, or a Centralab No. X-21 bushing ground down to 0.853 inches long, will serve as the insulated spacer. Or, a Centralab No. X-20 3/4-inch long spacer can be used, along with 0.103-inch thick spacer washer.

The Allen D. Cardwell Co. has made a special 4-section split-stator variable capacitor, Cat. No. PL-8081, that also may be used for C₁₂ in this amplifier. Since this capacitor has an air gap of only 0.100 inches, the rotor must be insulated from ground. This may be done with small angle brackets fastened to the end plates, mounted in turn on suitable ceramic insulators about 1 1/2 inches high.

An insulated shaft coupling also must be inserted in the shaft drive. The best place for this seems to be in the shaft which runs down from the right-angle drive to the shaft bushing that passes through the chassis.

Since this capacitor has higher maximum capacity than the original, lower inductance tank coils may be used at L₁ on 80 and 40 meters. Both the original coils and the suggested substitute coils for the PL-8081 capacitor have been tabulated separately.

Meters were not included in this amplifier because of the complex shielding required around them. Instead, they may be mounted on a separate meter panel near the amplifier, or else the meters and power wiring used on another final amplifier in the transmitter may be switched to this amplifier. The following sketch suggests meter and switching connections for power wiring running to this amplifier.

Technical Tidbits

CAUTION—Screen Grid at Work

The screen grid is probably the most critical single element in modern high-gain tubes and yet it is undoubtedly the most abused element. The average ham looks upon the screen grid as an element which is *supposed to be* fixed in potential, and because the screen seems to go no place in particular in the circuit he completely neglects it. He feels that once he has connected the screen voltage lead that he is through with that part of the circuit until the rig wears out. (The latest census lists 1,269,321 cases of parasitics due to improperly bypassed and stabilized screen circuits. The adding machine broke down before the number of resultant key clicks was totaled.—Editor's note.)

If the screen is important, let us see why. The best way to do this is to compare triodes and screen-grid tubes. A comparison on this basis brings out the following points.

(a) In a triode there is a large capacitance between grid and plate. If this capacitance is not taken care of by neutralization, the resultant feedback voltage may cause oscillation. In a screen-grid tube, the screen, *if suitably bypassed*, acts as an electrostatic shield between grid and plate and therefore materially reduces the feedback.

(b) The plate voltage (and grid voltage) in a triode determines the amount of cathode current that flows. In a screen-grid tube the plate voltage has a negligible effect in determining the amount of cathode current because the screen acts as a shield between plate and cathode. It is the screen voltage (and grid voltage) which controls electron flow in a screen-grid tube, just as the plate voltage controls the electron flow in a triode. Obviously then, if the current flow is to be held constant, then the screen voltage must necessarily be held absolutely constant.

Thinking now of an actual circuit using a screen-grid tube, what do the above two points mean? Let us assume a screen-grid tube in the final of our rig. With the antenna tightly coupled to the final tank coil, we find that the plate current isn't high enough to suit us. The link is therefore coupled tighter and tighter in an endeavour to get more input. However, the plate current does not increase appreciably. At this point the average ham decides that his antenna won't load up properly. Actually all that happened was to be expected. In point "b" we stated that the current depended upon the screen voltage. Inasmuch as the screen voltage was not affected by increased loading, we found it difficult to change the plate current. All that was accomplished by the increased loading was a decrease in power output, because the plate voltage swing was decreased as the loading was increased and the plate dissipation went up.

Taking the other extreme of loading—too little load—we come to the exception in rule "b." That is, too little loading will bring on a condition where the plate voltage will affect the cathode current. Practically this means that if the final is lightly loaded,

the screen current will be high (even over rating), the plate current low, efficiency poor, and output low. This is true because a lightly loaded final (using screen-grid tubes) will have a large voltage swing, and the minimum voltage on the plate will occur when maximum current should flow. With a low enough plate voltage, the electrons in the tube will not be attracted to the plate as strongly as usual. These electrons will therefore tend to collect on the screen-grid. This large increase in screen current may harm the screen, as it is a flimsy element in comparison to the plate, and is not capable of dissipating too much energy.

Many amateurs have found from first-hand experience that this last point is true. When an ECO is lightly loaded so that this effect takes place, a slight change in loading will change the frequency quite a good deal, whereas the same ECO, when heavily loaded, will be less affected frequency-wise by a load change.

Adding up the information above gives us data by which we may formulate four rules for operating screen-grid tubes to make them do the fine job they were designed to do.

1. Carefully bypass and install the screen circuit so that it acts as a good shielding device. This means that the bypass condenser leads should be short and properly placed. Also, external shielding should be used on the tube if such is recommended.

2. Make certain that the screen voltage is accurately held to the design value. If the circuit is keyed this may require a separate, stable source of voltage. It is also important that an accurate voltmeter be used. The voltmeter part of volt-ohmmeters, especially home-made units, may easily be off 20—30% if the volt-ohmmeter is an old instrument.

3. Make all loading adjustments carefully for maximum power output and maximum circuit efficiency. Loading an amplifier or final too lightly or too heavily will cause poor circuit and tube efficiency. Maximum power output will be obtained when the loading is neither too light or too heavy.

4. Install a screen current monitoring position. A screen current meter, connected in the circuit at all times is to be preferred. This will help to avoid accidental damage to the screen due to overload. Also, a screen current meter is an invaluable aid in the tuning-up process, as this meter is much more sensitive as a tuning indicator than the plate current meter.

When a screen-grid circuit is unloaded, plate current will be very low and the screen-grid current will be high. As the loading is increased the screen current will drop off as the plate current rises. A point will be reached where further loading does not affect the screen current. This is the approximate point of proper loading. A further refinement would be to check power output as the loading was changed, and adjust the loading for maximum output.—Lighthouse Larry.

BANDSWITCHING MOBILE LINEAR AMPLIFIER

WITH GL-4D21/4-125-A's

By W. C. Louden, W8WFH



KILOWATT MOBILE LINEAR AMPLIFIER installed in W8WFH's station wagon over the left rear wheel housing. Power supplies delivering 2,500 volts DC for the GL-4D21/4-125A amplifier tube plates, and 600 volts DC for the screen grids, are in the metal

box under the floor. The metal box next to the amplifier contains a motor-driven, remote-tuned oscillator, heterodyning and driver stages for the amplifier. The SSB generator, and audio and VOX circuits are under the front seat.

STABILITY AND RELIABILITY are of prime importance in mobile radio equipment. This well-shielded linear amplifier meets these requirements and has components rated for a full kilowatt DC input in class AB₁ or AB₂ operation. It is also well-suited for home-station installations.

The high power sensitivity of modern tetrode and beam pentode transmitting tubes simplifies the construction of an amateur transmitter since they require only low driving power, and thus, a simple exciter. Two

GL-4D21/4-125A tetrodes were connected in parallel in this amplifier in a tuned-grid, tuned-plate circuit, as shown in the schematic diagram, Fig. 1.

COMMERCIALLY MADE GRID AND PLATE tank circuits, as specified in TABLE I — PARTS LIST, were found to have the correct inductances for the grid and plate circuits over the range of 3.5 to 30 megacycles. The plate pi-network loading capacitor C₄ is a standard 3-gang broadcast type variable.

TABLE I — PARTS LIST MOBILE LINEAR AMPLIFIER

- | | |
|--|--|
| <p>C₁.....10 — 200-mmf variable (Part of Harrington GP-50 tuned circuit).</p> <p>C₂.....1-11-mmf neutralizing capacitor.</p> <p>C₃.....15-250-mmf variable, 3,000 volt spacing.</p> <p>C₄.....30 — 1140-mmf variable (3-section broadcast receiver capacitor with 10 — 380-mmf per section).</p> <p>J₁, J₂chassis coaxial cable connectors.</p> <p>L₁.....grid coil assembly (part of GP-50).</p> <p>L₂.....10-microhenry coil with taps and switch S₂ (Barker & Williamson Model 851 pi-network tank circuit).</p> <p>L₃, L₄, L₅, L₆, L₇.parasitic suppressor chokes made from 6 turns of No. 16 enameled wire on 2 watt, 47-ohm composition resistors.</p> | <p>M₁.....0 — 50-milliampere DC milliammeter (G.E. Model DW-91, or equivalent).</p> <p>R₁, R₂.....0.667 ohms, 2 watts; resistance wire wound on 2-watt resistors.</p> <p>RFC₁, RFC₃.....2.5-milihenry, 4 pi r.f. choke, 125-milliampere rating.</p> <p>RFC₂.200-microhenry solenoid wound r.f. choke (National R-175A, or Barker & Williamson No. 800).</p> <p>S₁.....2-pole, 5-position ceramic rotary top switch (Part of GP-50).</p> <p>S₂.....1 pole, 5-position top switch (Part of B & W 851 coil).</p> <p>S₃.....2-pole, 5-position rotary tap switch.</p> <p>T₁, T₂.....5-volt, 6.5-ampere filament transformers, 12 or 115-volt primaries.</p> |
|--|--|

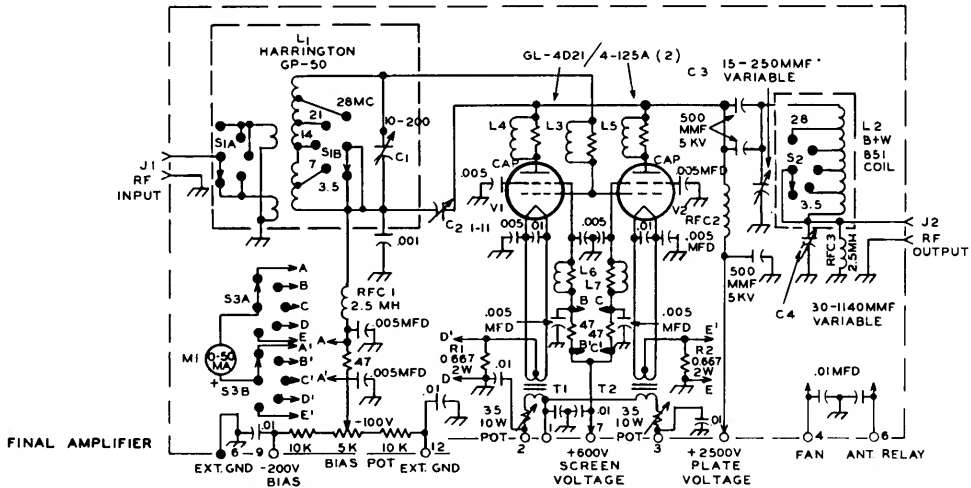

FIG. 1. SCHEMATIC DIAGRAM of the GL-4D21/4-125-A mobile linear amplifier. The 0.001, 0.005 and 0.01-mfd capacitances shown as bypasses in various circuits are disc ceramic capacitors, with DC voltage ratings at least double the operating voltage of each circuit. Resistances are in ohms, 1/2 watt rating unless otherwise specified. Components C₁, L₁ and S₁ are included in the Harrington GP-50 grid tank circuit; L₂ and S₂ are included in the B & W 851 pi-network plate tank circuit.

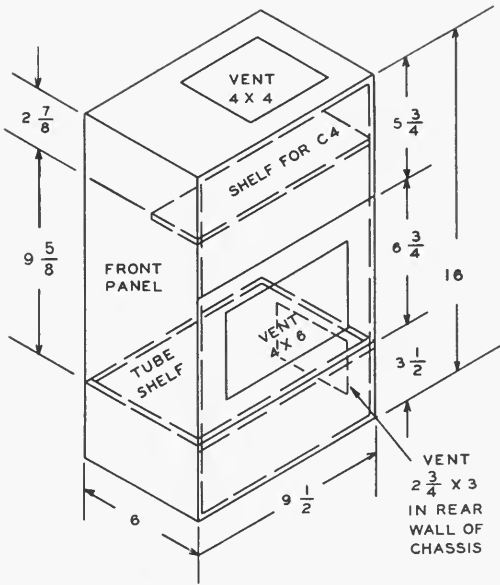

FIG. 2. CABINET DRAWING for the mobile linear amplifier. This cabinet was fabricated from $\frac{1}{8}$ -inch thick sheet aluminum, with flanges for side shields.

Capacitive bridge neutralization was included in the circuit to ensure stability on all bands. This bridge is formed by the tube capacitances, plus C_2 and the 0.001-mfd capacitor from C_1 to ground.

Separate current metering was provided for the screen grid and cathode circuits of each tube to check on the balance of power between them. A 0 to 50-milliamper DC current meter is switched across resistors in the control grid (A) and screen grid (B & C) metering positions of S_3 . In the cathode circuits (D & E), 0.667-ohm shunts multiply the meter reading by 4 times for a full scale reading of 200 milliamperes in each circuit. If the separate metering of cathode currents is not necessary, a single filament transformer may be used.

If GL-4-250A/5D22 or GL-4-400A tetrodes are used in this amplifier, larger filament transformers are needed. Also, if these tubes will be operated near maximum power, a heavier plate tank coil, the B & W Model 850A, which requires more space, should be substituted for the Model 851 coil. Type GL-813 pentodes also may be used in this amplifier by installing the proper sockets and filament transformers.

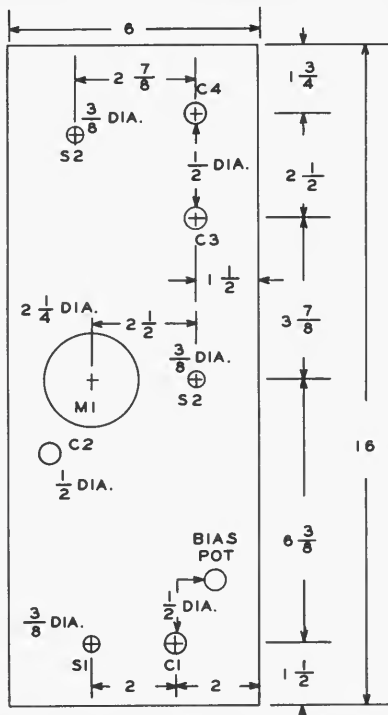

FIG. 3. PANEL LAYOUT DIAGRAM for the amplifier. Only major hole locations are shown. Locations of small holes for hardware should be located from the part being mounted. Cut meter hole to a diameter slightly larger than case of meter.



PANEL VIEW of the linear amplifier. Note that grid and plate bandswitches have separate knobs, and are not ganged. Snap-in buttons cover the holes through which the neutralizing capacitor (C_2) and bias potentiometer are adjusted.

THE SHIELDED ENCLOSURE for the amplifier, shown in Fig 2, was fabricated from $\frac{1}{8}$ -inch thick sheet aluminum. All sides were made as separate pieces with flanges on them for assembly to adjacent pieces with machine screws and nuts, or self-tapping screws. The shelves and vent holes should be added before holes are cut for mounting the components. Vent holes may be covered with aluminum screening or perforated sheet.

The front panel layout, Fig. 3, and the sub-chassis shelf layout, Fig. 4, are correct for the components specified in the PARTS LIST. Holes should be relocated to suit other brands of components as necessary. Locations for small parts can be determined from the pictures.

Although no commercially made enclosure of similar dimensions is available, a 6 x 10 x 3-inch aluminum chassis or Minibox (Bud CU-3010) could be used as a chassis base and fitted with the 6 x 16-inch front panel. A frame of aluminum angle covered with perforated sheet aluminum would make a good r.f. shield and support the upper shelf.

COMPONENT SUBSTITUTIONS may be made, as long as their electrical and mechanical characteristics are similar. The neutralizing capacitor, C_2 , may be a Bud NC-853, Millen 15011, or Johnson 159-125. Or, a suitable capacitor may be made by mounting two aluminum plates about 1 x 4 inches spaced about $\frac{1}{2}$ inch apart on standoff insulators.

The upper shelf may be dropped about an inch if necessary to allow room for a larger B & W Model 850A plate tank circuit which should be used with the larger tubes. The vernier tuning dials for the grid and plate circuits are Lafayette type F-346, 3 inches in diameter. National type AM dials also are suitable.

Power wiring was run with insulated wire of sufficient size to carry the voltages and currents in the various circuits. Leads carrying the grid and plate r.f. currents should be of $\frac{3}{32}$ x $\frac{1}{2}$ -inch copper strip. In the plate tank

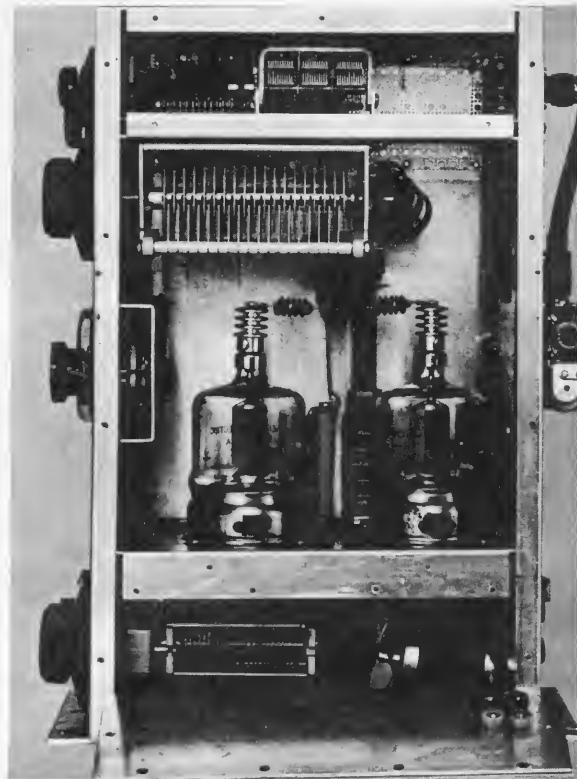

SIDE VIEW of the amplifier. A "U" shaped bracket (Bud CB-1628 miniature chassis) behind the panel shields the meter (M_1) and meter switch (S_2) from strong r.f. field present around the plate tank circuit.

circuit, use joints fastened with brass machine screws instead of solder when possible.

The fan shown is simply a small 12-volt DC motor with a fan blade. It pulls cool air into the chassis through the $2\frac{3}{4}$ x 3-inch vent in the chassis, forces it up through the holes in the tube sockets, and out through the upper vents in the box.

The antenna changeover relay was mounted on the outside of the cabinet where it would be easily accessible. Power for the

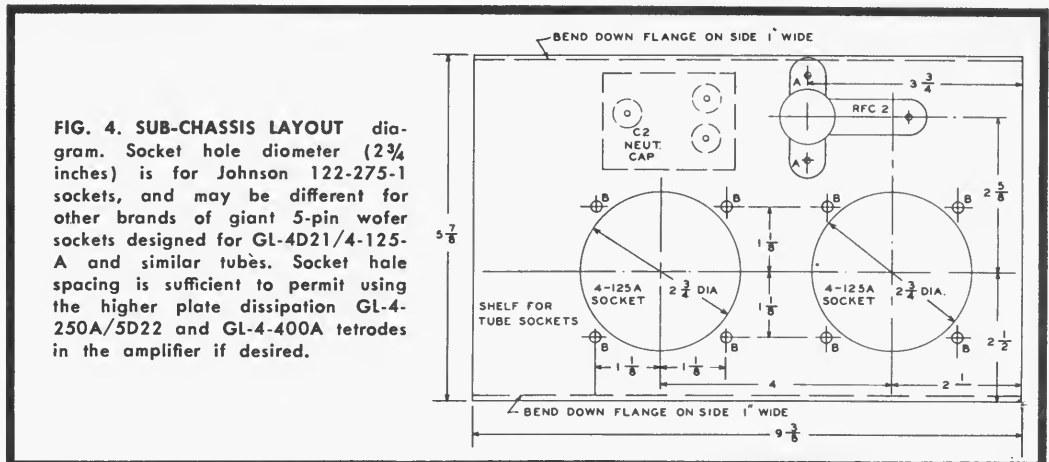
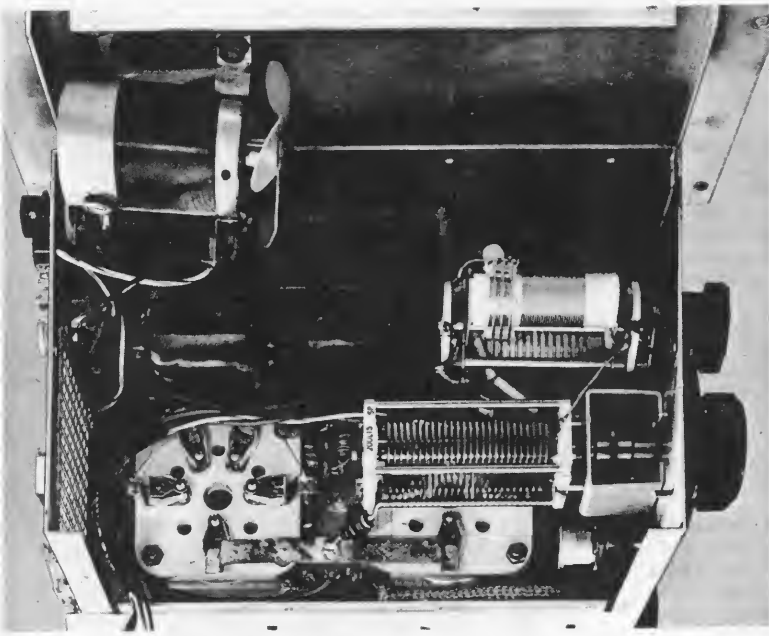

FIG. 4. SUB-CHASSIS LAYOUT diagram. Socket hole diameter ($2\frac{3}{4}$ inches) is for Johnson 122-275-1 sockets, and may be different for other brands of giant 5-pin wofler sockets designed for GL-4D21/4-125-A and similar tubes. Socket hole spacing is sufficient to permit using the higher plate dissipation GL-4-250A/5D22 and GL-4-400A tetrodes in the amplifier if desired.



BOTTOM VIEW of the linear amplifier. Note $\frac{3}{8}$ -inch wide copper strip connection between the control grid terminals on the tube sockets. Fan under the chassis forces air up through holes in the tube sockets, due to tight construction of lower part of box. Air cools seals in bases of tubes, then passes out through holes in bases and up along glass envelopes.

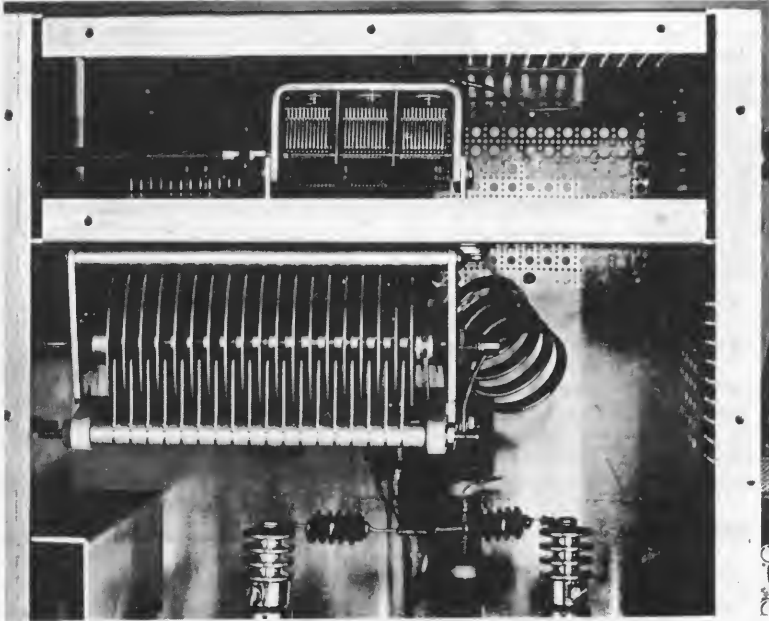

PLATE TANK CIRCUIT of the linear amplifier. Plate tuning capacitor, C_3 , is suspended from shelf, with pi-network loading capacitor C_4 mounted on shelf. The 28-megacycle coil was removed from the B & W Model 851 pi-network tank circuit frame and mounted between C_3 and the other section of coil. L_2 is mounted upside down from the top of the cabinet.

relay coil was brought into the amplifier through the 12-pin plug (Jones P-312-AB) along with the other low and medium voltage circuits. Bypass capacitors were connected to each pin on this plug, as well as used liberally throughout the amplifier, to keep r.f. currents off the power wiring.

INITIAL TESTING should preferably be done in a home station where checks and adjustments can be made more easily than in a vehicle. The test setup should preferably have a dummy antenna load, and have provision for reducing and turning off plate and screen voltages. First apply filament power, bias voltage and r.f. excitation to the am-

plifier so that the neutralizing adjustment can be made. About 5 watts of r.f. excitation at 14 megacycles or higher is necessary. This will give a grid current reading of 10 to 15 milliamperes.

Set S_1 in position "A" and tune the grid circuit for maximum current, making sure that the grid and plate bandswitches are in the proper position. Then, with loading capacitor C_4 near maximum capacitance, "rock" the plate tuning capacitor, C_3 , back and forth, watching for a quick fluctuation in grid current at one point on the dial for C_3 . Adjust the neutralizing capacitor, C_2 , until the grid current is constant.

BIBLIOGRAPHY OF INFORMATION ON LINEAR AMPLIFIER TESTING

"Adjustment of Class B Linear Amplifiers," *RADIO HANDBOOK*, 14th Edition, by Editors and Engineers, page 278.

"Two Tone Tests and Their Meaning," by Don Stoner, W6TNS, *NEW SIDEBAND HANDBOOK*, page 151.

"How to Test and Align a Linear Amplifier," by Robert W. Ehrlich, WØJSM, *SINGLE SIDEBAND FOR THE RADIO AMATEUR*, page 134; also in *QST*, May, 1952, page 39; and the *RADIO AMATEUR'S HANDBOOK*, page 314.

As a final check for neutralization, remove the r.f. drive, apply about half of normal plate and screen voltages, and reduce the grid bias so that the plate current increases to near maximum plate dissipation for the tubes used. Rotate both the grid and plate tuning capacitors to see if the amplifier will break into oscillation at any combination of settings. This test should be tried on all bands. If an oscillation is noticed, readjust C_2 slightly until the oscillation disappears.

After turning off power, connect the amplifier to a suitable dummy antenna load having a 50-ohm impedance and power capability of at least 500 watts. Insert a standing wave ratio bridge in the coaxial cable between the amplifier and dummy antenna. Apply r.f. drive, and about half of normal plate and screen voltages, and tune the amplifier for maximum output.

If the amplifier appears to function normally, apply full plate and screen voltages. Adjust C_1 so that each tube draws about 150 milliamperes plate current (for GL-4D21/4-125A tubes). Check to see if maximum power output on the SWR indicator occurs at the same setting of C_2 as the minimum plate current dip. Any major differences in plate or screen currents drawn by each tube indicates that one tube may be better.

Preferably, a SSB exciter should be used to drive the amplifier, so that linearity tests can be run on the amplifier before installation in the vehicle. If excess driving power is available from the exciter, a 5,000-ohm, 25-watt non-inductive resistor (Sprague 25NIT-5000 or equivalent) can be connected across C_1 to swamp the excess drive. Complete descriptions of linearity tests are given in the amateur radio handbooks, as listed in the bibliography on page 6.

INSTALLATION IN THE VEHICLE is simply a matter of mounting the amplifier securely so

that it will not shake or vibrate excessively while the vehicle is in motion. Connect each filament transformer primary across a different phase of the 3-phase AC power source in the vehicle. Heater power for the exciter should be obtained from the third phase to balance the heater load.

In W8WFH's installation, bias voltage is obtained from a small 200-volt negative single-phase AC supply, while 600 volts for the GL-4D21/4-125A screen grids is delivered by a 300/600-volt 3-phase star bridge rectifier supply which also powers the exciter from the 300-volt tap (Fig. 9 on page 7 of the July-August, 1960 issue). A 2500-volt 3-phase plate supply is used, but plate voltages up to 3000 are suitable.

W8WFH does not recommend regulating the bias and screen grid voltages for the amplifier. Plate voltage may fluctuate more than 10 percent due to variations in the alternator output voltage with engine speed — from 100 volts at idle, to 120 volts at road speeds — and plate current peaks during modulation. By allowing the bias and screen grid voltages to fluctuate in accordance with the plate voltage, a fairly *constant ratio* is maintained among these three voltages, and amplifier linearity is improved.

A husky mobile antenna is required for this amplifier. W8DLD and W8WFH have constructed their own antennas with separate center-loading coils for each band. Details will be published in a forthcoming issue. Check with the manufacturer of the mobile antenna you may be considering, to ensure that it will withstand the several hundred watts of power output delivered by this amplifier.

If you want real performance in your mobile amateur radio installation, follow the proven recommendations published in this 3-part series in *G-E HAM NEWS*.

TECHNICAL TIDBITS

Proper Tank Circuit Padding

There comes a time when practically every ham wants to take a high-frequency rig and by hook or crook, make it work on a lower frequency. This involves wiring around frequency multiplier stages and winding new coils. It also involves worrying about the fact that the tuning condensers are of too low a capacitance to meet the requirements for a proper Q. The usual reaction to this problem is to parallel the old condensers with fixed capacitance of some sort, vacuum capacitors, discarded tuning condensers or anything which will add the proper capacitance.

Unless proper procedures are followed in this padding stunt, it is very likely that a nice case of TVI will be developed, or perhaps a polite note from the FCC regarding harmonic emission. There is a right and a wrong way to add padding capacitance across a tuned circuit.

If the circuit considered is a single tube circuit with a single-ended plate tank, that is, one which has a single-section tuning condenser and a coil where the B plus voltage feeds in at the bottom,

then no further worrying need be done. Padding capacitance may be added directly across the tuning condenser and the circuit will not be changed effectively by the added capacitance.

However, if the circuit is a single tube circuit with a double-ended plate tank, which is needed if the tube is neutralized, or if the circuit is a push-pull circuit, where again a double-ended plate tank is used, then we must watch out for gremlins. These gremlins take the shape of undesired harmonic signal output. Second harmonic, third harmonic and other harmonic signals will be present in the plate tank coil and thus be radiated if we allow these various harmonic currents to flow through the coil and induce their own voltages in the coil. To minimize the possibility of radiating these harmonics, it is necessary only to keep these harmonic currents from flowing through the final tank coil.

With reference to Fig. 7A, this circuit is one which is commonly used with either a single tube or a push-pull stage. C_1 is the tuning condenser and C_x the usual bypass condenser. When this circuit is

tuned to resonance, it will have a very high impedance to current which comes from the tube and which is an r-f current at the fundamental frequency. However, current is also coming from the tube at radio frequencies which are harmonics of the fundamental frequency. These harmonic currents do not see the tank circuit as a resonant tank, but they merely see the tank circuit as a combination of inductance and capacitance, the inductance acting as a choke and the capacitance acting as a bypass condenser. These harmonic currents, like the fundamental current, are trying to find a path to ground. Naturally they will take the lowest impedance path. In Fig. 7A the only path for these harmonic currents is the path through the coil proper, through condenser C_x , and thence to ground.

If one tube is considered, then the path is through the top of the coil, whereas with a push-pull circuit, one tube sends its currents through the top of the coil and the other tube through the bottom of the coil. In any case, these harmonic currents are passing through the coil, and therefore they induce a harmonic voltage in the coil. Further, as higher and higher harmonics are considered the coil becomes a better and better choke, therefore the higher and higher a harmonic voltage will be induced. This means that the antenna link will pick up these voltages, send them on to the antenna, which will radiate these harmonics. Of course, many stunts are used in order to prevent the harmonic voltage from being coupled to the antenna, but we are interested here in preventing the harmonic voltage from existing.

How is this done? Refer to Fig. 7B. This is identical to Fig. 7A except that C_1 has been replaced with a split-stator condenser C_2 . Now, when harmonic currents come from the tube, they are faced with the problem of whether to go through the coil (with its increasingly high impedance to higher and higher frequency harmonics), or whether to go through the split-stator condenser, C_2 , (whose impedance is decreasing with frequency and which is becoming more and more effective as a bypass condenser as higher order harmonics are considered). Because of the difference in the impedance of these two paths, most of the harmonic current will take the path through C_2 .

Before we start praising this circuit too greatly, however, let us examine it more closely. The two halves of the coil are coupled together and the center-tap is rather firmly tied to ground through condenser C_x . If these two halves of the coil are overcoupled, as is usually the case, then the resonant curve for the entire coil may turn out to have a double hump. This is a nasty situation because it is then impossible to tune C_2 properly. If C_2 is set for the resonant frequency, then the impedance of the coil is not what it should be, and if C_2 is tuned so that the impedance is correct, then the circuit is not exactly at resonance.

This situation may be avoided by a few quick

twists of a soldering iron, so that the circuit resembles that in Fig 7C. Another equally correct circuit would be with C_z omitted and the center of C_3 grounded, with the r-f choke disconnected from the center of C_3 , or any combination of the above. The important thing is to omit the bypass condenser which you occasionally find tied to the center of the tank coil. The introduction of the r-f choke in the center-tap lead of the coil in Fig. 7C and the omission of the bypass condenser at the center-tap point practically guarantees that all of the harmonic current will flow through C_3 to ground.

Now what about this padding that we started to discuss early in this article? In Fig. 7A, a padding condenser (C_A) would normally be added directly across C_1 . Inasmuch as this circuit is already beyond hope, we are adding the last coffin nail by so doing. Ergo, don't add C_A as shown. If you insist on using that circuit, the least that can be done is to add two padding condensers in series across C_1 . Then, if the junction of these two padding condensers is tied directly to ground, or bypassed to ground, we have minimized harmonic radiation by providing a low impedance path to ground. Also, with these series padders in place, we can remove C_x and store it in the junk box. Now that that has been done, note that this circuit is now a brother of the circuit in Fig. 7C.

Fig. 7B is a circuit that it is best to stay away from, but if it were to be used, two padding condensers should be used, at C_B , one each across the two sections of the tuning condenser C_2 . If at this point you can talk yourself into removing the bypass condenser, C_x , you will have made this circuit into another brother of the one in Fig. 7C. Referring to this latter circuit, padding capacitance should be added as indicated at C_C . If a single padding condenser were added directly across the whole tank coil then the harmonic currents could get to ground only through the original split-stator condenser C_3 , which is now extremely small in capacitance compared to the rest of the circuit, and hence rather ineffectual. The current would divide, some going through this condenser, and the rest through the coil. This division of current would depend on the exact values of the capacitance and the inductance, but the point is that much current would be passing through the tank coil, and therefore producing harmonic voltages, which need not pass through if the padding capacitance were also made up in a split-stator arrangement.

Summing up all of the above, make sure that you have the proper circuit to start with. Then, when you add padding capacitance to this circuit to reach a lower frequency, make sure that you parallel both sections of the split-stator condenser with individual padding condensers. Your reward will be an improvement in tube efficiency and a silent muttered prayer from your neighbors.—Lighthouse Larry.

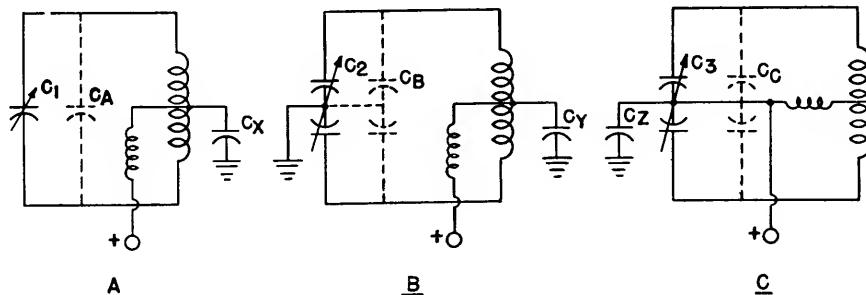

Fig. 7. Double-Ended Output Tank Circuits Discussed Above.

We have mentioned at several places in the article on the Power Peaker something about tank circuit Q's, which possibly might have left some of our readers wondering what significance it all has in the design and operation of radio gear. The fact is that operating Q's have a very profound effect on the performance of most of the equipment we have, so a little working knowledge of the subject might serve as a useful guide in the selection of components and operating conditions in equipment we hams use every day. Do not blame us if you are moved to check into some of your gear after reading this discussion and make changes which improve the operation (more output, less TVI, cooler tubes, and the like) of equipment at your station.

The term "Q" is applied to the ratio of reactive power (wattless power) in a circuit to real power. From this basic definition of Q follows many interesting corollary relations in electrical circuits, although the concept is not in the least limited to the field of electricity. Immediately one can say that the Q of resistance is zero, and that the Q of a perfect coil or condenser is infinite. These are the absolute limits of Q's, but they are broad enough to provide plenty of room for error—or design, whichever way you may look at it.

What can a person do about Q if he buys a coil that has a Q of 250, and the designer of a circuit says such and so circuit should have a Q of 25? Are the manufacturers kidding; are they soaking us for a lot of Q we do not need; or does the designer of the circuit think that any old coil will do if it will fit into the coil socket? No, the manufacturer is talking about his *product* when he says its Q is 250; the designer is talking about his *circuit* which generally involves more than the coil alone, and he should know enough about it to pick components which are the right ones for the job. One of the fundamental properties of a coil of wire is its inductance. Disregarding distributed capacity (which can become a headache sometimes), the reactance of a coil is proportional to the product of its inductance and the frequency at which it is operated. Pure reactances are nice to talk about, but coils are not actually 100% pure reactances by the time you buy or make one—the wire has resistance! This resistance is generally distributed throughout the coil, as is the reactance, but let us think of it as being all drained down to the bottom of the coil in one chunk of pure resistance, leaving pure reactance at the top. If the reactance portion of this *series* circuit of pure reactance and pure resistance has a value of 250 ohms, and the resistance is one ohm, the Q of the coil is 250; or, concisely,

$$Q \text{ coil} = \frac{\text{Reactance (X)}}{\text{Resistance (R)}} = \frac{250}{1} = 250.$$

This is consistent with the basic definition given earlier. What we have said about coils is equally true of capacitors, but it turns out that condensers can be made with much higher Q's than coils generally have, so we worry about coils a little more than capacitors when speaking about Q's of the circuit elements we use.

Well, if we apply 1000 volts RMS to this coil having a reactance of 250 ohms and a resistance of one ohm (the impedance is very, very nearly 250 ohms, not 251 ohms), 4 amperes of current will flow through both reactance and resistance, and the *real* power in the coil is 16 watts (which shows up as heat) and the reactive power is 4000 volt-amperes, so called to distinguish wattless power from real power. The heat generated in this transaction represents energy lost—or at least energy converted from electrical form (that can be used conveniently) into heat that warms the coil and does not ever show up as energy in the antenna. What of it? Why worry about

16 watts lost when we have 4000 volt-amperes reactive power in the coil? If volt-amperes were what we were after, this would be fine. Think of it—4000 volt-amperes that cost only 16 watts! A good bargain? Not bad if we know our P's (powers) and Q's, but that is the rest of the story. The circuit designer can now take over where the coil builder left off.

As we all know, a capacitor in parallel with a coil makes a tuned circuit. It turns out that at the resonant frequency of this circuit the reactance of the capacitor is equal to the reactance of the coil. If we tune our coil with a capacitor having a Q of 5000 (not unusual) we can truly neglect the 8/10 of a watt lost in the equivalent resistance of the capacitor compared with the 4000 volt-amperes of reactive power (not lost—yet) in the coil and capacitor, and the 16 watts loss in the coil. Now let us add a fourth circuit element to the reactance and resistance of the coil and the reactance of the capacitor comprising the tuned (tank) circuit we are talking about. Let us make this one a resistance, and let us put it across the condenser of the tank circuit. If 1000 volts is still supplied across the coil, it now appears across the resistance and the capacitor as well. A little over 16 watts has already been accounted for in the coil and condenser so what about the new resistor? Well, a current of E/R flows in it, and power is consumed in the resistance—no doubt about it. It is already pretty hot!

How much power goes into this resistor? That is an easy one. The power is

$$P \text{ (watts)} = \frac{E^2}{R} = \frac{1,000,000}{R \text{ (Ohms)}}$$

since the voltage E is 1000 volts, RMS, by hypothesis. If R is 5000 ohms, the power is 200 watts and the circuit Q is now

$$Q \text{ (circuit)} = \frac{\text{Reactive Power}}{\text{Real Power}} = \frac{4000}{216} = 18.5$$

according to our basic definition of Q stated at the outset.

Let us not be quite so crude about it. Suppose the *equivalent* of this resistance is put across the capacitor by *coupling* a load to the coil and adjusting the coupling until the power delivered to the load is 200 watts. If the coupling job did not disturb the tuning, the circuit Q is still 18.5, and the generator feeding this circuit is unable to detect the difference. It still has to supply 216 real watts as before and 4000 volt-amperes to the coil and the capacitor of the tank circuit. In fact, the generator does not even feel the 4000 VA in the coil because the 4000 VA in the capacitor happens to cancel the reactive power of the coil! That is co-operation on a pretty big scale, but nobody should be surprised about it—this is what happens at resonance. Has the bargain evaporated? Not entirely, although the 4000 VA has slipped through our fingers somehow. Pfoof! That was wattless power anyway. We did get 200 watts of good output from our circuit that loaded the generator to 216 watts, so the circuit efficiency is

$$\eta \text{ (circuit)} = \frac{200}{216} \times 100 = 92.6\%, \text{ a pretty fair bargain}$$

at that. Had we loaded the circuit to extract only 100 watts, the circuit efficiency would have been $100/116 \times 100 = 86.3\%$, not quite so good. The circuit Q in this case would have been 34.5. If the circuit were not loaded at all, the circuit efficiency would have been zero, with a Q of almost 250, about the same as that of the coil. Loading the circuit so that 400 watts is delivered would give a circuit efficiency of $100 \times \frac{400}{416} =$

96.2% with a circuit Q of 9.62. Which loading would you choose? To answer that we must consider the characteristics of the generator and the signal it generates.

If the generator had sinusoidal waveform (no har-

monics) the tank circuit would not be needed at all, and so the load circuit efficiency would be very close to 100% at any power level. But the generators we are interested in are vacuum tubes running as class B or C amplifiers, generally. A class B amplifier delivers a signal that is only half of a sine wave, and a class C amplifier does even less. The tank circuit helps the tube, which delivers only half of a sine wave (or less), to deliver a whole sine wave to the load. The degree to which this is done is almost directly proportional to the operating Q of the circuit. Thus, the tank circuit serves as a much needed coupling device between the tube and the load, and by various adjustments of coupling, we can make a fixed value of load resistance present a chosen value of load into which the tube (generator) actually delivers power. A little power loss in the tank circuit is justifiable, since we have limited control over the actual load resistance and the tube characteristics; i.e., the optimum load for the tube itself. We have seen that the power output of the generator depends on the load resistance presented to it, in this case across the capacitor of the tank circuit. For a given tube and mode of operation (class A, AB, B, or C) there is a definite best loading. Too light a load will not allow a reasonable output power; too heavy a load, on the other hand, wastes power in the tube (generator) and makes it overheat. All of these factors indicate a compromise, with the circuit designer as referee. It has been found that circuit Q's of about 10 or more make the tube happy—accept power for half a cycle or less and deliver power for a whole cycle. The numerical example showed us that the higher circuit Q's had lower efficiencies (with a fixed coil Q) so this tends to push the choice of circuit Q down.

The response of a tuned circuit to harmonics is approximately $\frac{1}{nQ}$, where n is the order of the harmonic (2 for second, 3 for third, etc.), so this consideration makes a choice of high Q desirable. A good all-around choice of operating Q is from 12 to 15, a compromise to be sure. Now we do some juggling. We want to present the optimum load to the tube, but we must keep it happy. We also want to have good discrimination against harmonics present in the output of the tube. In addition, we want to waste as little of the tube's output power as possible; that is, we want good over-all efficiency. Having chosen the operating voltage for the tube, the optimum resonant load resistance is fixed. Taking this and a value of

circuit Q around 12 to 15 we can solve for the reactance of the coil and the condenser by substituting values in the following equation:

$$\text{Reactance} = \frac{\text{Load Resistance desired}}{Q \text{ (circuit)}}$$

This is the value that must be used to obtain the desired output power at good tube efficiency, at reasonable circuit efficiency, and with reasonable harmonic attenuation. Circuit Q affects all these things. The Q of the coil alone determines the power loss in the coil, once its reactance is established. Doubling the Q of the coil alone will cut the power loss in the coil itself to half—a desirable move for the sake of the coil—but this is not so easy, and the circuit efficiency will be raised only a little bit (from 96%, say, to 98%, a little difficult to detect on the scale of the output power). Doubling the coil Q will not affect *in the least* the loss occurring in the tube itself. That loss is determined by the load into which the tube works, and by the mode of operation; i.e., class A, B, or C.

It takes no magician to apply the foregoing information intelligently. In the Power Peaker amplifier, for example, the output circuit Q was chosen at about 15. (This will vary somewhat throughout a given band because of tuning.) The choice of 1500 volts (the highest allowed by the tube manufacturer) was made to get the greatest useable output power, and this sets the value of load resistance and coil reactance at any operating frequency. The numbers used in the foregoing numerical examples are quite close to those actually appearing in the Power Peaker amplifier. That is all there was to it. Easy? You betcha!

One more comment. If a Q of 12 or 15 is so good for the output circuit why was a Q of 25 chosen for the input (grid circuit) of the Power Peaker? Two main considerations guided this choice. The input load of the GL811-A depends somewhat on the loading in the output circuit. In order to have some latitude for error, the Q of the input circuit was made higher than actually necessary so that things would be on the safe side. The other consideration was this: the exciter, when coupled to the amplifier grid circuit, lowers the grid-circuit Q. Thus, it is quite probable that the working Q of the grid tank circuit will be around 15, after all.

Watch your P's and Q's. Keep your tubes happy, get more power out of your rig, lower the harmonic output, and save money in the choice of suitable components.

SIDEBAND RECEPTION AND ADAPTERS— THE SIGNAL SLICER

Four-Tube Receiver Adapter for Improved Reception of
AM, NBFM, CW or SSB Signals

From July-August, 1951



Fig. 1. Front view of the Signal Slicer. The input cable is at the left of the unit.

Ever since the SSB, Jr. transmitter appeared in the G-E Ham News my readers have been asking whether it would be possible to design a simplified receiver adapter incorporating the same simple phase-shift network. The Signal Slicer described in this issue is W2KUI's answer to those questions.

—Lighthouse Larry

**ANOTHER
G-E HAM NEWS
SSB SPECIAL**

Signal Slicer

The Signal Slicer is a complete receiver adapter for converting the conventional communications receiver having 450-500 kilocycle I-F to a single-sideband receiver. The system utilized to obtain single-sideband response is of the phase-shift type, utilizing either a commercially made or a home-built phase-shift network of the type described for the SSB, Jr., transmitter (G-E *Ham News*, Vol. 5, No. 6). The name Signal Slicer has been applied to this adapter because of its ability to slice the selectivity curve of the conventional receiver in two, permitting one to listen at will to signals in either the upper or lower frequency portion of the receiver's normal I-F selectivity curve.

In contrast to the original SSB receiver adapter (G-E *Ham News*, Vol. 3, No. 6) the Signal Slicer requires no vacuum-tube probe, utilizes only four double-purpose tubes, and has no carrier synchronizing circuit. Notwithstanding a rather drastic reduction in its complexity, this adapter is a practical answer to the question, "Why not describe a simplified single-sideband receiver adapter?"

The Signal Slicer, when attached to a communications receiver, gives you a combination which permits you to do away with at least fifty percent of the QRM when receiving conventional AM or phase-modulated phone signals. The same holds true for the reception of CW signals, with the Signal Slicer supplying the heterodyning signal so that the BFO in the communications receiver is not required. True single-signal

reception of CW signals is possible with this combination.

For reception of single-sideband signals, this adapter furnishes a carrier against which the sidebands may be demodulated. By selecting the proper sideband with a switch, the modulation may be read. Although it is now pretty well understood that a special adapter is not required for reception of single-sideband signals, many amateurs who have heard or used the original *Ham News* SSB receiver adapter appreciate the benefits of such a device.

CIRCUIT DESCRIPTION

The complete circuit diagram for the Signal Slicer is shown in Fig. 2. As is the case for most equipment described in the *Ham News*, an effort has been made to utilize completely standard components wherever possible. The built-in power supply is a conventional voltage doubler with a selenium rectifier and a conventional resistance-capacitance filter. No further comment on this portion of the circuit is necessary except to point out that a transformer is used to isolate the circuits from the a-c line in order to prevent interconnection problems between the adapter and the communications receiver.

The phase-shift type of adapter consists basically of two detectors (demodulators) supplied by a signal to be received and signals from an oscillator which acts as a local carrier source. The outputs of the

Electrical Circuit

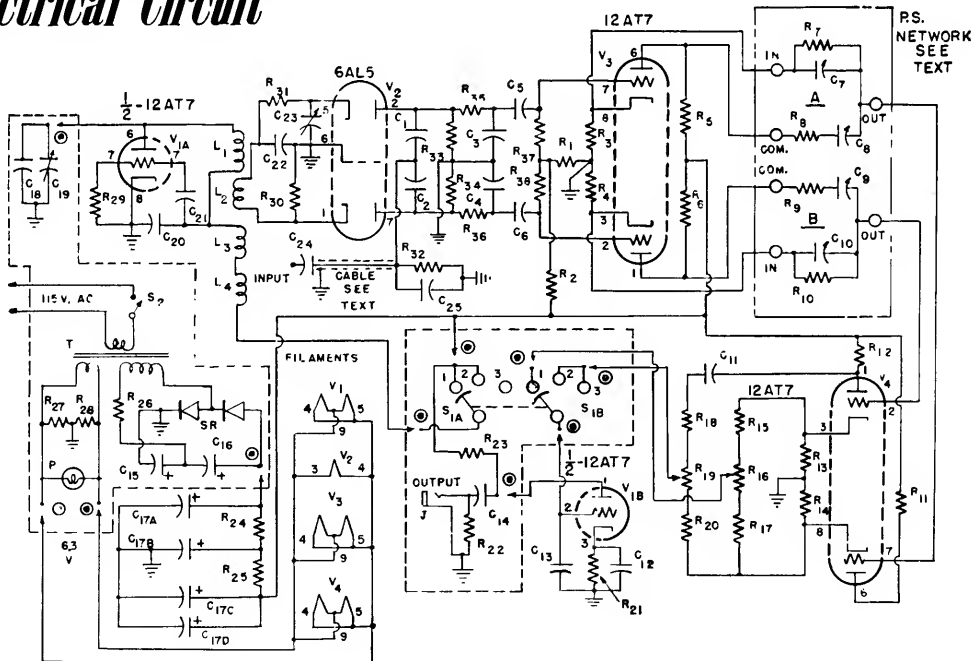

Fig. 2. Circuit diagram of the Signal Slicer.

separate demodulators are fed through a pair of phase shifters of such characteristics that the algebraic sum of their outputs consists of audio signals created by I-F signals which lie on one side of the local oscillator frequency, and the algebraic difference consists of audio signals created by I-F signals which are on the other side of the local oscillator frequency.

In the Signal Slicer half of the double triode V_1 is used as a Colpitts oscillator whose output is coupled into the two halves of the double-diode V_2 acting as the two demodulators. These demodulators are also supplied with signals from the I-F amplifier of the receiver with which the adapter is used. The demodulator outputs are supplied to the double triode V_3 which in turn feeds two phase-shift networks (Millen No. 75012 or a home-made equivalent).

The outputs of the phase-shift networks are then applied to the two triode sections of V_4 whose outputs are fed to the combining circuits (R_{15} , R_{16} , R_{17} and R_{18} , R_{19} , R_{20}). These, in turn, feed through a selector switch into an audio amplifier, the remaining section of V_1 . The purpose of the selector switch is to permit choice of sideband and to permit conventional receiver operation. With reference to the circuit diagram, positions 1 and 2 of switch S_1 are the two sideband positions, and position 3 is the proper position for normal operation of the receiver.

CONSTRUCTIONAL DETAILS

The Signal Slicer is simple to build, especially if a commercial unit is used for the phase-shift networks. The entire unit is built into a standard four by five by six inch utility box. Most of the components are mounted on one of the five by six inch removable cover plates. This plate will be referred to as the "top."

Refer to the circuit diagram, Fig. 2. Note that two groups of components are shown inside dotted-line boxes. The components that are in these two boxes are those that are mounted on the utility box proper. All the other components are mounted on the top plate, including the phase-shift network assembly which has been indicated in the circuit diagram inside a dashed-line box. This box is marked "P.S. Network." Don't confuse this with the two dotted-line boxes in the diagram.

It may be seen that each of the two dotted-line boxes has connection points indicated by a circle with a large dot inside. There are ten of these points. These represent the connections that must be made when the wiring of the box is complete and the wiring of the top plate is complete, and you are assembling the two sections. The leads shown with the arrow at each of these points indicate a length of wire which is left long so that the connection may be made after assembly. The photograph of the top plate in Fig. 3 shows these ten wires clearly. The wires are longer

CIRCUIT CONSTANTS

(All resistors and capacitors $\pm 20\%$ tolerance unless specified otherwise)

C_1, C_2	100 mmf mica or ceramic (matched within 5%)	R_3, R_9	94,000 ohm (100,000 ohm $\frac{1}{2}$ watt $\pm 1\%$ precision resistor in parallel with a 1.5 megohm $\frac{1}{2}$ watt $\pm 5\%$ resistor)
C_3, C_4	100 mmf mica or ceramic (matched within 5%)	$R_{11}, R_{12}, R_{13},$ R_{14}	3,000 ohm, $\frac{1}{2}$ watt ($\pm 5\%$)
C_5, C_6	0.01 mf mica, paper or ceramic	$R_{15}, R_{17}, R_{18},$ R_{20}	220,000 ohm, $\frac{1}{2}$ watt ($\pm 10\%$)
C_7	2430 mmf (0.002 mf mica $\pm 5\%$ with 170-780 mmf trimmer in parallel)	R_{16}, R_{19}	100,000 ohm potentiometer
C_8	4860 mmf (0.0043 mf mica $\pm 5\%$ with 170-780 mmf trimmer in parallel)	R_{21}	5,600 ohm, $\frac{1}{2}$ watt ($\pm 10\%$)
C_9	1215 mmf (0.001 mf mica $\pm 5\%$ with 50-380 mmf trimmer in parallel)	R_{22}	2.2 megohm, $\frac{1}{2}$ watt
C_{10}	607.5 mmf (500 mmf mica $\pm 10\%$ with 9-180 mmf trimmer in parallel)	R_{23}	47,000 ohm, 1 watt
C_{11}, C_{14}	0.1 mf 400 volt paper	R_{24}, R_{25}	470 ohm, 1 watt
C_{12}	0.5 mf 200 volt paper	R_{26}	400 ohm, 4 watt ($\pm 10\%$) (Two 200 ohm, 2 watt resistors in series)
C_{13}, C_{25}	470 mmf mica or ceramic	R_{27}, R_{28}	47 ohm, $\frac{1}{2}$ watt
C_{15}, C_{16}	40 mf 150 volt electrolytic	R_{29}, R_{32}	10,000 ohm, $\frac{1}{2}$ watt
C_{17A}, B, C, D	20—20—20—20 mf 450 volt electrolytic	R_{30}	1,000 ohm, 1 watt ($\pm 5\%$)
C_{18}	300 mmf mica $\pm 5\%$, for 456 to 465 KC. (Use 240 mmf for 500 KC, I-F receivers)	R_{31}	1,000 ohm, $\frac{1}{2}$ watt ($\pm 10\%$)
C_{19}	50 mmf variable (Hammarlund HF-50)	R_{33}, R_{34}	1.0 megohm, $\frac{1}{2}$ watt ($\pm 10\%$)
C_{20}	0.003 mf mica $\pm 10\%$	R_{35}, R_{36}	51,000 ohm, $\frac{1}{2}$ watt (matched within 5%)
C_{21}	1000 mmf mica or ceramic	R_{37}, R_{38}	3.3 megohm, $\frac{1}{2}$ watt ($\pm 10\%$)
C_{22}	330 mmf mica $\pm 5\%$	S_1	Double pole, three position shorting type rotary switch
C_{23}	5-50 mmf mica trimmer (El Menco T-52210)	S_2	SPST Toggle Switch
C_{24}	10 mmf mica or ceramic	SR	Voltage doubler type selenium rectifier, rated 160 RMS volts at 100 ma (Federal 1008A)
J	Open circuit jack	P	6.3-volt pilot lamp
L_1, L_2, L_3, L_4	All made from one R-F choke (see text)	T	Power Transformer, 135-volt A-C RMS secondary at 75 ma, 6.3 volts at 1.5 amps (Thordarson R-22R12)
R_1	10,000 ohm, $\frac{1}{2}$ watt ($\pm 10\%$)	$P.S. Net-$ $work$	Millen No. 75012 or home-made equivalent (see text)
R_2	680,000 ohm, $\frac{1}{2}$ watt ($\pm 10\%$)		
R_3, R_4	2,000 ohm, $\frac{1}{2}$ watt precision ($\pm 1\%$)		
R_5, R_6	7,000 ohm, $\frac{1}{2}$ watt precision ($\pm 1\%$)		
R_7, R_{10}	133,300 ohm, $\frac{1}{2}$ watt precision ($\pm 1\%$)		

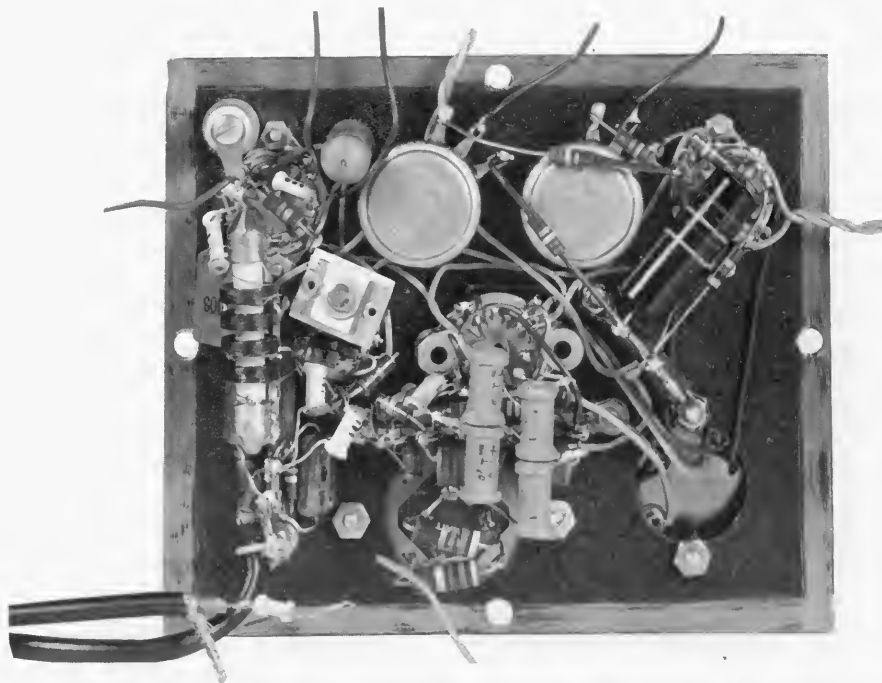

Fig. 3. Detail view of the wiring on the top panel of the Signal Slicer.

than the photograph shows. Make each one about 5 inches long, then cut them to length when assembling the adapter.

A drilling layout is shown in Figs. 6, 7 and 8 for those who wish to duplicate the original unit exactly. If another type of construction appeals to you, a reasonable duplication of the layout shown is suggested.

With reference to Fig. 4, the power transformer, the selenium rectifier, condensers C_{15} , C_{16} and resistor R_{25} are mounted on the rear apron of the utility box. This rear apron also has two grommets mounted on it to handle the a-c line and the input probe cable. On the front apron you mount the pilot light, power switch S_2 , resistors R_{27} , R_{28} , oscillator tuning control C_{18} , C_{19} , output jack, selector switch S_1 , condenser C_{14} and resistors R_{22} and R_{23} . All the wiring involved with these components can easily be completed if the two removable plates are not in place. Because of tolerances on certain components and the particular I-F of your receiver, it is well to mount C_{18} directly across C_{19} so that possible pruning operations may be done conveniently without removing the top plate.

The one inch diameter hole specified for the phase-shift network is used regardless of whether a Millen unit or a home-made unit is employed. Details of the home-made unit will be given later.

It is desirable to remove the paint from the top lip of the utility box, and from the four edges of the top plate, to ensure good electrical contact when the two parts are joined.

Coils L_1 , L_2 , L_3 and L_4 require explanation. All four coils are made by making some minor changes on a single National R-100 R-F choke. This choke has four pies, and each pie becomes a coil. To make the necessary changes, refer to Fig. 5, and proceed as follows. Examine the coil and the individual pies. You will note that one lead on each pie comes off the outside of the pie, and the other lead comes from the part of the pie nearest the ceramic support. Orient the choke in your hand until it is as shown in Fig. 5,

that is, so that the lead from the right-hand end goes to the outside of the farthest-right pie, L_1 .

Carefully loosen two turns on the outside of L_2 and then cut the wire to provide an inch or so of lead from the inside of coil L_1 . Remove the insulation and the enamel from the end of this lead. The two connections to coil L_1 are now the original pigtail and the inch or so of wire removed from the outside of coil L_2 .

Repeat this operation on coil L_3 to provide leads for coil L_2 , as well as a connecting lead from L_3 to L_1 . Continue as shown in Fig. 5 until you have L_1 in series with L_3 and L_4 , with L_2 having separate, unconnected leads. Tin the ends of all wires and solder the connection between L_1 and L_3 . Double-check to make certain that your leads are as shown in Fig. 5, that is, that the leads come from the top of the pie where so indicated and from the center of the pie, where so indicated. This is important, because this determines the direction of the winding on the form. The entire procedure probably will take less time to do than the time you have spent reading this. The inductance of each pie of the National R-100 choke is approximately 420 microhenries.

For wiring details of the top of the Signal Slicer, refer to Fig. 3. The coil assembly (L_1 through L_4) is mounted with the L_1 end fastened to a ceramic stand-off post and the other end connected to one lug of a terminal strip. The common connection of L_1 and L_3 should be made to the end lug of the terminal strip nearest V_1 , and the two connections from L_2 to the next two lugs. Make certain that the coil will clear the lip on the box as the chassis is mounted. The remainder of the wiring is quite straightforward and should present no difficulty. Note that R_5 and R_6 are actually each made up of a 3000 and a 4000 ohm resistor in series, since 7000 ohm resistors were not immediately available.

Remember to leave several inches of hookup wire at each of the ten connection points, so that the final assembly consists in cutting these wires to length and

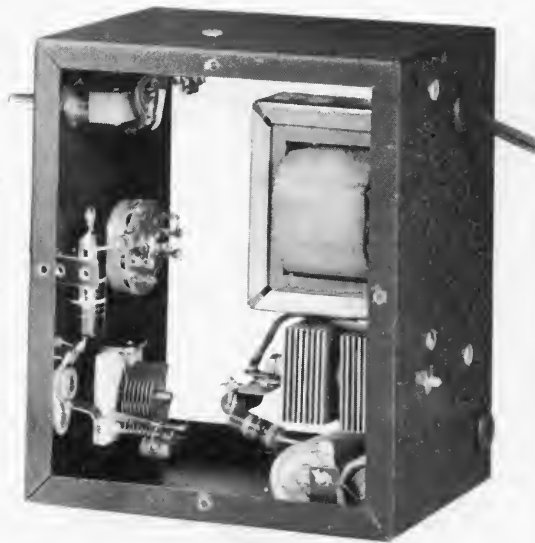

Fig. 4. Detail view of the completely wired interior of the Signal Slicer.

soldering them to the proper points on the box proper. Obviously, all wiring should be completed on the top plate before the final connections to the box are made. The probe cable should be made of approximately two feet of RG-58/U cable, and C_{24} soldered to the far end. The cable may be shorter or longer, but try to keep its length under six feet.

PHASE SHIFT NETWORKS

The Millen No. 75012 network is a complete and aligned pair of phase-shift networks. To use this unit in the Signal Slicer a slight modification is required to achieve optimum results. Each of the 100,000 ohm precision resistors (R_8 and R_9 in the circuit) should be paralleled with a 1.5 megohm five percent tolerance $\frac{1}{2}$ watt carbon resistor. To do this the can must be taken apart to permit access to the resistors. The photograph (Fig. 9) shows where these resistors have been added to the Millen unit. Make no other changes or adjustments, since these units are pre-aligned at the factory.

The change mentioned is beneficial in taking account of the effective source impedance presented by V_3 and associated circuits.

If desired, you may make your own phase-shift network unit. The home-made unit pictured in Figs. 10 and 11 is made in a Millen No. 74400 plug-in shield can. The octal base pictured is a part of this unit. The components are supported on a vertically-mounted piece of insulating material, such as bakelite, poly, etc. The size of this piece is $3\frac{5}{8}$ by $1\frac{3}{4}$ inches by $\frac{1}{8}$ inch thick. This is secured to the mounting posts by two small right-angle brackets. The suggested terminal arrangement is pictured quite clearly in Figs. 10 and 11. The fixed mica condensers are mounted on one side of the insulating material, and the adjustable trimmers and resistors on the other side. Mount, but do not solder these components in place until the phase-shift networks have been aligned.

The suggested pin connections for a home-made unit are as follows: Pin 1, ground; pins 2, 3 and 4, network "A"; and pins 6, 7 and 8, network "B."

Electrically the two networks in this can are identical to the ones used in the SSB, Jr., except for the modification noted above for the Millen unit. (For convenience, the symbol numbers indicated in Fig. 2 in this issue are the same as were used in Figs. 2 and 3A of the Vol. 5, No. 6, *Ham News* describing the SSB, Jr.)

After completing the phase-shift unit leave the can cover off until the adjustments are made and the two 1.5 megohm resistors added across R_8 and R_9 . Run a wire from pin 1 on the phase-shift unit to one of the mounting posts inside the No. 74400 can to allow grounding. To prevent inadvertent short circuits, a stiff piece of insulating material (such as waxed Kraft paper) should be placed inside the can as is usually done in commercial I-F transformers.

If a home-made phase-shift network is used, an octal socket will be required on the top plate to accommodate the Millen No. 74400 unit. The alignment of the home-made phase-shift network will be discussed later.

COMPONENT PARTS

As is true with many equipment designs, there are some component parts in the Signal Slicer that must be chosen carefully. The precision resistors specified are important if optimum results are to be obtained. Continental "Nobleloy" 1% resistors were used in the original models of the Signal Slicer (where 1% resistors are specified) although any other make of equal quality should work equally well.

Some of the other resistors are specified with tolerances of 5% or 10%. This has been done to ensure a piece of equipment which will be capable of being tuned up properly after you complete it. If you desire, use 20% tolerance resistors which you have measured to make certain that they are within the required tolerance. Certainly one or two of these values may vary as much as 20%, but if all the resistors varied this much, in the wrong direction, you might have a much harder job getting the unit to work properly.

The adjustable mica trimmers used in the phase-shift networks may be any good grade of trimmer. Those actually used are El Menco: T52910 for C_7 and C_8 ; T52510 for C_9 ; and T52310 for C_{10} .

It is important that you use a National R-100 2.5 mh. choke for L_1 , L_2 , L_3 and L_4 . Other chokes will undoubtedly work, but the National R-100 is universally available, and no attempt was made to check the suitability of other four-pie 2.5 mh. chokes.

Mica condensers should be used where mica only is specified. In the other cases the specifications call for "mica or ceramic" or "mica, ceramic or paper" condensers. In general, the ceramic condensers are smaller than either the mica or paper condensers and should therefore be used if feasible. Be certain to obtain condensers within the tolerances specified.

The selector switch, S_1 , should be of the shorting type. Loud switching transients will be produced unless this precaution is observed.

The selenium rectifier specified is capable of handling 160 volts RMS. Most small selenium rectifiers are rated for only 130 volts RMS, and these were not specified because the transformer, unloaded, supplies more than 130 volts RMS, which would damage the lower-rated rectifier.

CIRCUIT ADJUSTMENTS

With the exception of alignment of the phase-shift networks (if you build your own) very few adjustments are required in the Signal Slicer. The two

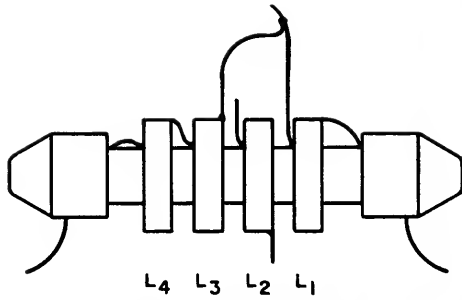

Fig. 5. Sketch of the altered R-100 choke

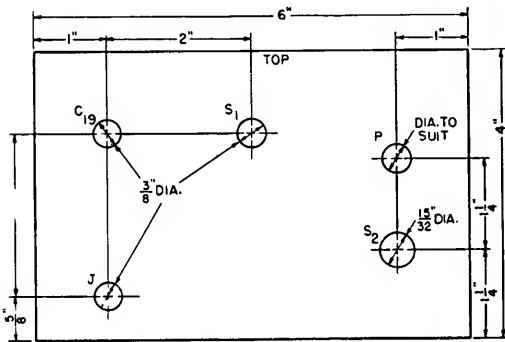

Fig. 6. Layout dimensions for the front of the Signal Slicer. The dimension on the left which is blank should be $1\frac{5}{8}$ inches. Note also that the holes for C_{19} and S_1 are not shown in true perspective, because they are actually closer to the bottom of the panel than the hole for the panel light. The dimensions shown are correct.

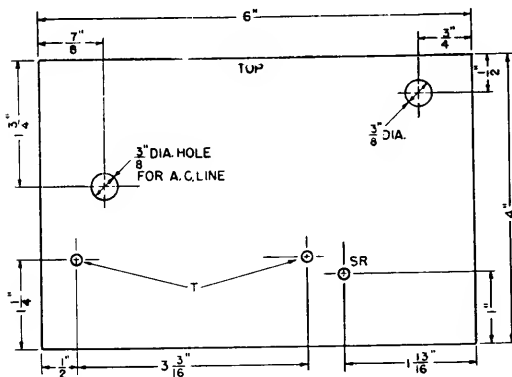

Fig. 7. Layout dimensions for the rear of the Signal Slicer.

methods for alignment of the home-made phase-shift networks are identical to those described for the SSB, Jr. The simpler method is to use accurately measured parts (R_7 through R_{10} and C_7 through C_{10}). The more exact method involves four test frequencies which enable one to adjust each of the four capacitors, C_7 through C_{10} for perfect alignment.

The adjustment procedure using the test frequencies is as follows. First, determine that the resistors R_7 and R_8 (as well as R_{10} and R_9) bear the ratio of 133,333 to 100,000, that is, 4 to 3, as closely as can be determined. If there is any doubt about the value of the resistors, double-check their values on an accurate bridge. Next procure the two necessary instruments, which are an audio oscillator capable of providing output frequencies in the range between 300 and 2000 cycles per second, with good waveform, and an oscilloscope. The oscillator may be calibrated by the method described later. Connect the oscillator output through a step-down transformer (a conventional audio transformer run "backward" will do nicely) into a 1000 or 2000 ohm potentiometer with the arm of the potentiometer grounded. See Fig. 12.

Adjust the arm position so that equal (but opposite) voltages appear on each half of the potentiometer. A steady audio frequency signal of any convenient frequency may be used with an oscilloscope acting as a convenient voltmeter for this job. Swing the vertical deflection lead from one end of the potentiometer to the other and adjust the arm to obtain equal voltages (a true center-tap). Set up a temporary double cathode-follower circuit using a 12AT7 with 500 ohms from each cathode to ground and connect as shown in Fig. 12. (It will be convenient to provide leads M, N, and 1 and 2 with clips at the ends to facilitate checking.) The horizontal and vertical plates of the oscilloscope should be connected to the 12AT7 cathodes as shown in Fig. 12 and the scope common connection should go to the arm of the potentiometer.

Now, refer to the circuit diagram, Fig. 2, and disconnect the elements in your home-made phase-shift network as follows. Disconnect the left-hand end of

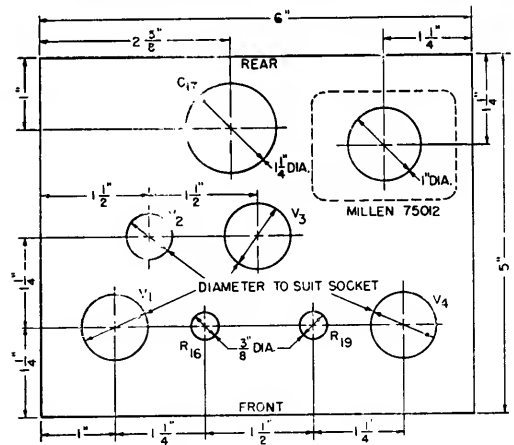

Fig. 8. Layout dimensions for the top panel of the Signal Slicer.

R₇ from C₇. Disconnect the left-hand end of R₁₀ from C₁₀. You are now ready to proceed with the alignment.

Connect lead M (Fig. 12) to the left-hand end of R₇ and connect lead N to the left-hand connection of C₇. Connect leads 1 and 2 (Fig. 12) to terminal M. Adjust the horizontal and vertical gains on the oscilloscope to produce a line about 1½ inches long slanted at 45 degrees when the oscillator is set to a frequency of 490 CPS. If the oscilloscope has negligible internal phase shift the display will be a straight line instead of a narrow slanting ellipse. If the latter display appears it is necessary to correct the oscilloscope phase shift externally by using an adjustable series resistance (a 50,000 ohm potentiometer) mounted at either the vertical or horizontal input terminal, depending on what correction is necessary.

At any rate, the objective here is to get a straight line at 490 CPS. In some cases a series capacitor may be needed to provide the necessary correction. Try values from 0.05 to 0.0005 mf. Now shift lead 1 from the left-hand end of R₇ to the junction of R₇ and C₇. Adjust the trimmer of C₇ to obtain a circle on the oscilloscope. It will be noted that as this adjustment is made the display will shift from an ellipse "leaning" to one side through a circle or ellipse (with axes parallel to the deflection axes) to an ellipse which leans the other way. If desired or necessary, the appropriate gain control on the oscilloscope may be changed so that a circle instead of a "right" ellipse is obtained at the point of correct adjustment. After changing the gain control on the oscilloscope, check (and correct, if necessary) the phase shift in the oscilloscope by moving lead 1 back to the left-hand end of R₇, and then repeat the setting of C₇ with lead 1 back again on the junction of R₇ and C₇.

In general, always make certain that the oscilloscope is used in a phase-corrected manner. As a double-check (if the deflection plates in the 'scope are skewed, for instance) connect lead 2 to the left-hand end of C₇. If the circle changes to a slanting ellipse, readjust C₇ to produce an ellipse half-way between the ellipse (obtained by switching lead 2)

and a circle. Changing lead 2 from the left-hand end of C₇ to the left-hand end of R₇ and back again should give identical skew to the display when C₇ is set correctly. Failure to get symmetrical ellipses (egg-shaped, or other display) is due to distortion, either in the oscilloscope, the oscillator, the transformer, or the cathode follower. Conduct the test at as low a signal level as possible to avoid distortion.

Next, connect lead M to the left-hand end of R₁₀ and lead N to the left-hand end of C₁₀. Connect leads 1 and 2 to lead M, set the oscillator frequency to 1960 CPS, correct 'scope phase-shift as before, and move lead 1 to the junction of C₁₀ and R₁₀. Adjust C₁₀ for a circle as was done for C₇, using the precautions outlined for that case.

Now connect lead M to the left-hand end of R₉ and lead N to the right-hand end of C₉. Connect leads 1 and 2 to lead M, set the oscillator frequency to 1307 CPS, correct 'scope phase-shift as before, and move lead 1 to the junction of R₉ and C₉. Adjust C₉ to obtain a circle on the oscilloscope, as before.

Repeat the above procedure for the remaining R-C pair, R₈ and C₈. Use an oscillator frequency of 326.7 CPS. This completes the alignment of the phase-shift network. None of the preceding alignment instructions need be carried out if a Millen No. 75012 network is used.

Re-connect the phase-shift units, connecting the left-hand end of R₇ to C₇, and the left-hand end of R₁₀ to C₁₀. Connect the phase-shift units to the base pins of the plug-in can assembly and solder all connections. Shunt R₈ and R₉ with the 1.5 megohm resistors previously mentioned, then place the cover on the plug-in assembly. Remember to use some insulating material inside the can as mentioned previously.

AUDIO OSCILLATOR CALIBRATION

It will be noted that the frequency ratios are such that the 12th harmonic of 326.7 CPS, the 8th harmonic of 490 CPS and the 3rd harmonic of 1306.7

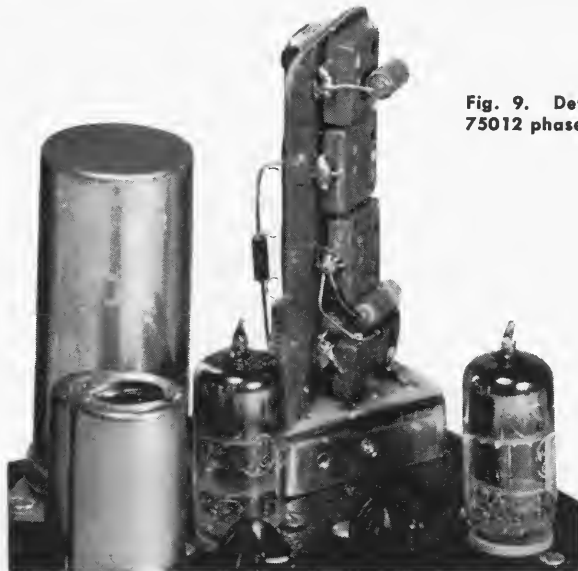

Fig. 9. Detail view of the Millen No. 75012 phase-shift network.

CPS are all the same as the 2nd harmonic of 1960 CPS, namely, 3920 CPS. Thus, if a stable source of 3920 CPS frequency (such as a thoroughly warm audio oscillator) be used as a reference, the frequency of the test oscillator can be set very closely to one-half, one-third, etc., of this reference frequency if both oscillators feed an oscilloscope and the resulting Lissajous figures observed.

Use of a calibrating frequency in this manner assures that the frequency ratios used are correct, even though the exact frequencies used are unknown. The frequency ratios (just as the resistance ratio previously mentioned) are far more important than the actual values of frequency (or resistance) used.

CONNECTION TO RECEIVER

After completion of the wiring and a thorough wire-check you are ready to connect the adapter to the receiver. The connection from the "hot" side of the I-F transformer to the diode plates of the detector in the receiver should be removed, and the audio connection from the detector output to the A-F gain control should be opened. The shield of the adapter cable connects to ground on the receiver, and the 10 mmf capacitor connects to the hot side of the I-F transformer, in place of the diode plates.

The output of the adapter may be used directly on headphones, or an audio lead may be plugged into the output jack of the adapter (J) and wired into the audio input of the receiver. It can be seen that the Signal Slicer essentially replaces the detector normally used in the receiver. The AVC action in most receivers so altered will now be completely out of service, as will the S-meter. (Even if the AVC is not disabled, it should not be used when using the Signal Slicer.) The RF gain control will be the main gain control of the receiver. It is difficult to give specific information for connection of the Signal Slicer to all receivers, but the above information covers most cases that will be encountered.

Some receivers have an accessory plug in the rear. Find out whether the amount of power available from this plug is ample to supply the requirements of the Signal Slicer if you contemplate borrowing the power from the receiver instead of using a built-in power supply. The heater power required is 6.3 volts at 1.2 amperes and the high voltage required is 250 to 300 volts at approximately 25 ma. It is recommended that the filter section consisting of R_{24} , R_{25} and C_{17} be retained regardless of the power supply used.

FINAL ADJUSTMENTS

Turn on both the receiver and the Signal Slicer and allow a few minutes warm-up time. The R-F gain control of the receiver should be all the way to zero and the AVC switch set for "manual" or "RF." Plug headphones into the output jack (J) on the adapter, set the selector switch to normal (position 3), advance the R-F gain until the receiver sounds "live" and tune in an AM station, governing the output with the R-F gain control. Keep this output reasonably low. Be certain to *tune* the receiver to maximum output (remember, there is no AVC and no S-meter) with minimum I-F bandwidth, if the receiver is so equipped, but do not use the crystal filter at this time. Trim the secondary of the last I-F transformer to compensate for any shift of its tuning caused by connection of the Signal Slicer input circuit. Set the two balance potentiometers (R_{16} and R_{19}) about midway and turn the selector switch on the adapter to one of the sideband positions (position 1 or 2). This actuates the oscillator in the Signal Slicer.

Tune the oscillator (with C_{19}) to zero beat with the received carrier, at which point good, clean audio reproduction should result. If the oscillator will not tune to zero beat within the range of C_{19} , replace C_{18} with different values of capacitance until zero beat can be obtained with C_{19} near mid-range.

Now, detune the receiver until a beat note of about 1000 CPS is heard. Try detuning first on one side, and then on the other, leaving the receiver set for the *weaker* heterodyne. Adjust the appropriate resistor (R_{16} or R_{19} , depending on the selector switch position) for a *minimum* heterodyne. Then detune the receiver to the other side of the signal, switch to the other sideband with the selector switch, and adjust the other potentiometer for a minimum heterodyne. Quite possibly neither minimum will be a complete null at this time.

Adjust C_{23} for a further reduction in heterodyne strength (readjusting the oscillator frequency with C_{19} if necessary to maintain the same beat note). Adjust the potentiometer (R_{16} or R_{19}) for still further reduction of heterodyne strength, switch to the other sideband position, retune the receiver for a beat note of 1000 CPS on the other side of zero beat, and adjust the other potentiometer for a minimum heterodyne signal strength. You will find that the sharpness of the minimum becomes more pronounced each time the above process is repeated until C_{23} is set at the optimum point, just as in balancing a bridge.

Throughout the above adjustment procedure it is assumed that the Signal Slicer is in working order other than for the correct settings of the few adjustments just covered. If no signal is heard at any time, or if excessive hum or other evidence of trouble appears, a thorough trouble-shooting routine is indicated.

OPERATING INFORMATION

After a short time of familiarization the user of the Signal Slicer will find that he listens almost exclusively to one or the other of the sideband positions, rarely ever going back to normal reception. In most cases reception of AM, NBFM, CW and Single-Sideband signals will be greatly improved over conventional reception methods. If interference appears when listening to one sideband of an AM or NBFM signal, simply switch to the other sideband to dodge the problem. Do not try to "tune out" interference—switch it out instead. Sometimes, even then, the going is rough, as we all know. That's the time to switch to normal reception to find out how rough it really is. At least, with the Signal Slicer, you can always get rid of the interference that appears on any one side of the received signal.

Since extremely close tuning (within 100 CPS) is generally necessary, the receiver should have a good bandspread arrangement, and should, therefore, have excellent stability. Some signals will be found where the Signal Slicer is of no advantage whatever because the signals themselves are characterized by excessive drift, syllabic instability, or other obvious faults. Then too, some receivers exhibit faults quite similar to those mentioned for transmitters. Do not expect the Signal Slicer to cure either a "rotten" signal or a receiver that, for instance, makes *all* CW signals sound rough, or one that has excessive drift.

In general, operate the receiver with the lowest R-F gain control setting that gives comfortable audio output. An overloaded receiver is just as bad as an overloaded transmitter (perhaps worse) as far as the listener is concerned. The crystal filter in the receiver may be used in the conventional manner.

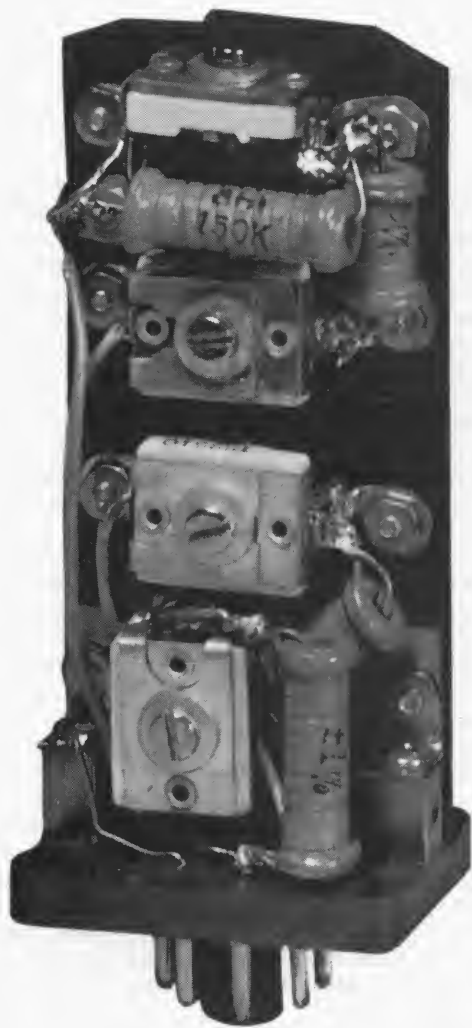

Fig. 10. Internal view of the front of the home-made phase-shift network.

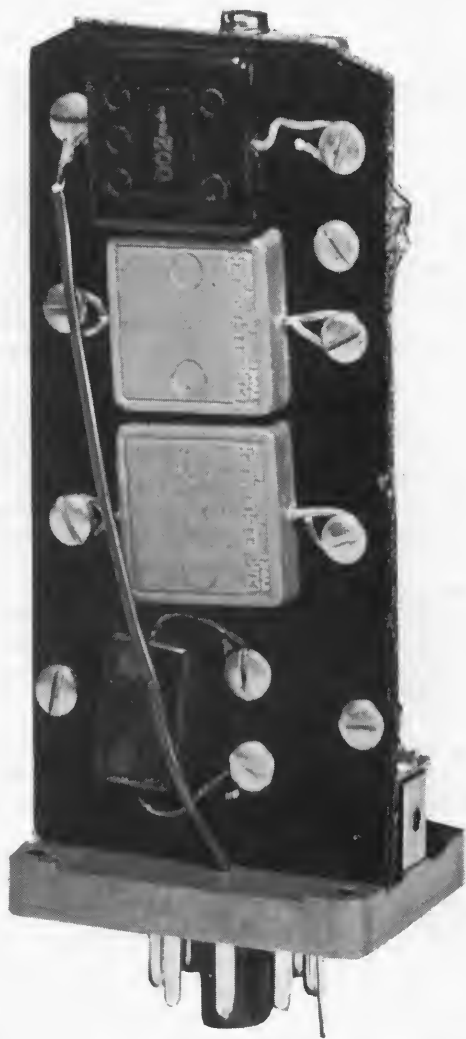

Fig. 11. Internal view of the rear of the home-made phase-shift network.

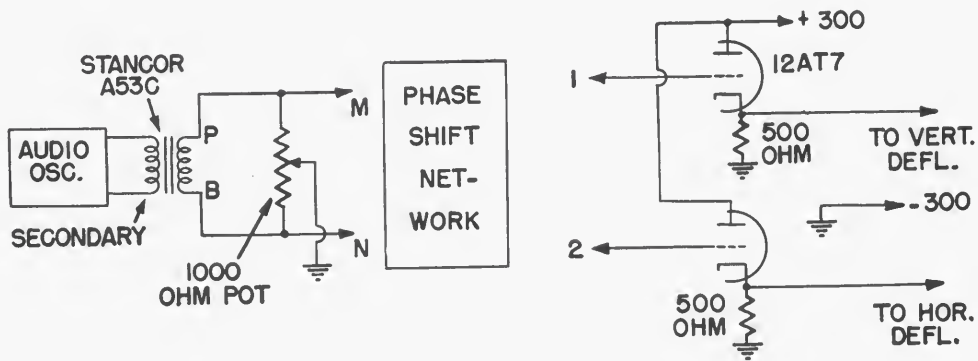

Fig. 12. Temporary layout required to test phase-shift networks.

Designers' Corner—Notes on the Application of the Signal Slicer

Many hams who do not operate single-sideband 'phone stations feel that a single-sideband receiving system would be of no use to them. The fact is, it is probably more useful to them for receiving CW and AM 'phone signals than it would be to a SSB enthusiast for receiving SSB signals (although the SSB ham has long since learned the usefulness of such a receiving system).

In other words, if the Signal Slicer is good for SSB 'phone reception (I can assure you it is—Ed.) it should be dandy for CW, especially traffic nets, where one or more of the stations may slip away from the crystal filter and turn up missing on a few receivers.

Going a bit further in our thinking, an AM 'phone station is just like two single-sideband stations (at the same carrier frequency) that just happen to be transmitting identical signals on opposite sidebands. Therefore, one isn't missing anything if he doesn't listen to one of the signals. The Signal Slicer allows the receiving operator to select which one of the signals he doesn't want to hear. This sounds ridiculous on the face of it, until you consider that one of these "stations" is liable to be severely heterodyned, which is a polite way of saying that the QRM on that station is terrible.

If this QRM situation exists, the operator can flip a switch and hear the same transmission on the other side, where no heterodyne exists. Obviously, the operator isn't choosy about which side he listens to, as long as he can hear the same thing on either side. This is what is known as broad-nosed selectivity with extremely steep side-slope—a rather valuable asset in many situations.

The Signal Slicer, however, goes one step beyond providing just usable selectivity as such. The demodulator is made as nearly distortionless as one could pray for, because *all* incoming signals are smaller by a factor of some 200 or better than the carrier signal that is supplied by the built-in oscillator to the detector system. This is exalted carrier operation with a vengeance, but it certainly pays handsome dividends.

One dividend is the elimination of "mushing up" when receiving a fading signal; another is in reduction of the apparent volume range of a fading signal—so much so that loss of the AVC function in a receiver using the Signal Slicer is actually a distinct gain. But, don't take my word for it—try it yourself.

A word about the demodulator circuit is in order at this point. You might be tempted (even as I was)

to use germanium diodes in place of the 6AL5 diode tube, and thus end up with a three-tube Signal Slicer. If you like to listen to noise this simplification is recommended. However, if you want a good SSB receiver adapter, use the 6AL5 or some other thermionic diode tube. My physicist friends tell me that the effective noise resistance of germanium diodes is extremely high, compared to a tube like the 6AL5, when you operate at low frequencies with only a few microamperes of d-c flowing in the circuit. My friends were correct. The tube is as quiet as a tomb lined with rock wool compared to the germanium diodes. For this particular application, a tube works out better than germanium diodes.

Somebody (perhaps it was Aesop or Confucius, I don't recall) said that the merit of a radio receiver was not in what it would receive, but in what it *wouldn't* receive. Of course, receivers have on-off switches, but what I mean is, doesn't your present receiver receive too much?

I am certain that you will agree that many, many times, on a single frequency, you have received more signals than you knew what to do with.

So, if these ancient philosophers were right, the Signal Slicer is a merit improver, although it's not perfect. The frequency range over which you can expect to get at least 40 db. signal rejection is controlled by the phase-shift network, and its range is 225 to 2750 cycles per second. This, of course, more than covers the region of most acute hearing, but what about the audio frequency range outside these limits?

At 4000 cycles the signal rejection due to the phase-shift network is between 36 and 37 db., and at 8000 cycles it is about 30 db. The audio amplifier in the Signal Slicer is deliberately designed to have a response which is down 3 db. at 4000 cycles, 9 db. down at 8000 cycles, etc. (This is at a rate of about 6 db. for each octave.) Thus, at the slight sacrifice of high fidelity it is fair to say that the signal rejection is about 40 db. all the way along, because the audio response has been tailored in an identical way on the low-frequency end of the spectrum.

Add to all of this the I-F selectivity curve of your receiver and you may begin to see why we think the Signal Slicer is really about as good as anyone might want when you consider the practical aspects of reception.—W2KUJ

—Lighthouse Larry

Added Information on the Signal Slicer

These comments should answer the many requests for information on substituting components and changing the operating frequency of the original G-E HAM NEWS SIGNAL SLICER.

SUBSTITUTING PHASE-SHIFT NETWORKS- Commercially-made phase-shift networks may be substituted for the network designed by Norgaard, shown on page 9 of the original article.

- a. **MILLEN No. 75012:** This network is housed in an aluminum can having about the same dimensions as the original. The parts values are the same, but connections are made through terminals on a recessed insulating board on the bottom of the network, as shown in Fig. 13 below.
- b. **CENTRAL ELECTRONICS No. PS-1 and LAKESHORE INDUSTRIES No. PS-Jr.:** Both of these networks are packaged in aluminum cans approximately the same size as the home-made network. Both have a special 9-pin octal type plug-in base. The matching socket for this plug is: Amphenol type 77MIP9; or 78RS9. Both of these networks have the same capacitance and resistance values as used in the original Norgaard network. Plug pin connections are shown in Fig. 14 below.
- c. **BARKER & WILLIAMSON Model 350, type 2Q4:** This popular network is very compact and is housed in an 8-pin octal based metal tube envelope the size of a 6J5 tube. Since the resistance values are higher, and the the capacitance values are smaller,

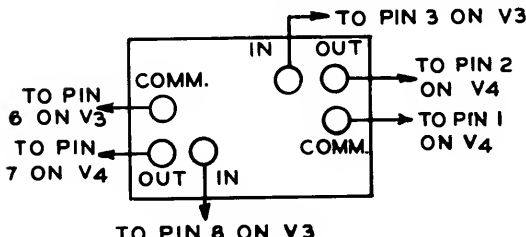

FIG. 1—CONNECTING DIAGRAM MILLEN NO. 75012 PHASE SHIFT NETWORK

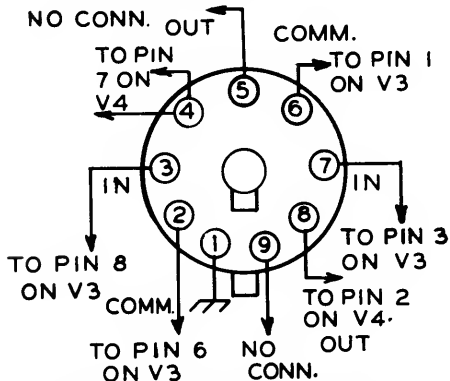

FIG. 2—CONNECTION DIAGRAM FOR CENTRAL ELECTRONICS PS-1 AND PS-JR. NETWORKS

stray and other external circuit capacitances may have a greater effect on the performance of this network than on the above types. This is the opinion of Norgaard, designer of the G-E HAM NEWS SSB equipment. Basing connections are shown in Fig. 15.

CHANGING THE MECHANICAL LAYOUT-- Although the original Signal Slicer was constructed in a 4 x 5 x 6-inch utility box, other sizes of chassis or boxes are equally suitable. The following precautions should be observed:

- a. Components should be kept approximately in the same relationship to each other as in the original model. This will keep stray circuit capacitances and coupling about the same.
- b. Since a portion of the Signal Slicer circuit operates at low audio level, it is best to keep the unit well away from components which have a strong magnetic field.

MODIFYING THE SIGNAL SLICER FOR OTHER INTERMEDIATE FREQUENCIES-- The recent appearance of receivers having intermediate frequencies other than the 450--500 kilocycle range for which the Signal Slicer was designed, has created a demand for information on modifying the Signal Slicer to work at these frequencies.

- a. Circuit constants in two tuned circuits must be changed, one circuit being formed by C_{18} , C_{19} and L_1 ; the other circuit consists of C_{22} and L_2 . Values for these components should be scaled up or down according to the ratio of the original frequency to the new frequency.
- b. For example, when shifting the Signal Slicer to 915 kilocycles (BC-348 receiver IF), values of the above components should be reduced by a ratio of 2:1; or, $1/2$ the value specified for 455 kilocycles. Windings L_1 and L_2 on the 2.5-mh RF choke should have about 30-percent of their turns removed to reduce the inductance to one-half the original value. Capacitor C_{18} should be 150 mmf; C_{19} , a 25-mmf variable; and C_{22} , about 165 mmf, for this frequency.

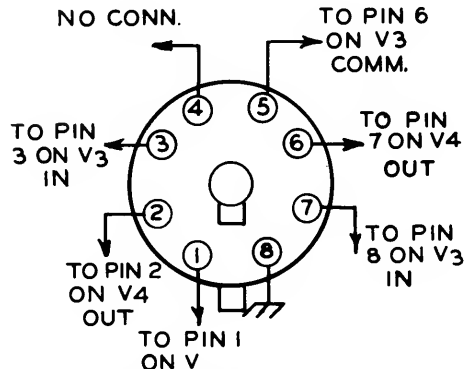

FIG. 3—CONNECTION DIAGRAM FOR B AND W MODEL 350, TYPE 2Q4 PHASE SHIFT NETWORK

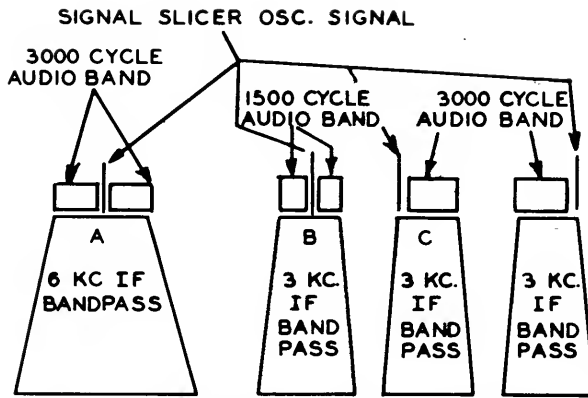

FIG. 4—DIAGRAM SHOWING RELATIVE POSITIONS OF OSCILLATOR SIGNAL AND AUDIO BANDS IF RECEIVER IF BANDPASS

- c. The oscillator tank (C_{18} , C_{19} , L_1) and the RF phase shift network (C_{22} and L_2) should be hooked up temporarily according to the schematic diagram. Remove what looks like an estimated 20-percent of the turns from L_1 , counting the number of turns removed. Check the resonant frequency of this circuit by listening for the oscillator signal on a broadcast receiver. Keep removing turns from L_1 until the oscillator tunes to 915 kilocycles with C_{19} about half meshed. Then remove the same number of turns from L_2 .

80--85- KILOCYCLE IF AMPLIFIERS--Increase C_{18} to 1600 mmf, C_{19} to a 100-mmf variable, and C_{22} to 1650 mmf. Also increase C_{23} to a 15--130-mmf mica trimmer capacitor. Substitute a National R-100 10-mh RF choke for the 2.5-mh RF choke. Make the same connections, but it should not be necessary to remove any turns from the windings. If the oscillator frequency is too high, add small mica capacitors (50 to 100 mmf) across C_{18} until the oscillator is on the correct frequency.

OPERATING THE SIGNAL SLICER WITH NARROW-BANDWIDTH RECEIVERS--The original Signal Slicer was designed to operate with receivers having an IF bandwidth of 6 kilocycles or more. The tuning procedure calls for setting the oscillator to the center of the IF passband (Fig. 4A).

- a. When using the Signal Slicer with receivers having a 2 to 3-kilocycle bandwidth, the oscillator frequency should be shifted when switching the sideband selector switch. If the oscillator in a Signal Slicer is set to the center of a 3-kilocycle IF passband, only audio frequencies below 1500 cycles will be heard, since the IF amplifier will pass only plus or minus 1500 cycles from the center frequency. This effect is shown in Fig. 4B.
- b. By setting the oscillator to one edge of the IF passband, as shown in Fig. 4C, the full 3000-cycle speech range will be within the IF passband of the

receiver. In order to change the oscillator frequency to the other side of the IF passband when shifting S_1 to receive the other sideband (Fig. 4D), a small fixed capacitor should be added across C_{18} . It will be necessary to add another section to S_1 to add this capacitance across C_{18} . This change is shown in Fig. 5. Just enough capacitance should be used for C_x to lower the oscillator frequency by 3 kilocycles. At 455 kilocycles, this will be about 5 to 10 mmf. It should be connected to both positions 1 and 2 on S_1C , to see which sideband position requires the lower oscillator frequency. This is best determined by experiment.

CRYSTAL CONTROLLED OSCILLATOR IN SIGNAL SLICER--The frequency stability of the oscillator in the Signal Slicer is sufficiently good for long-term operation without adjustment. However, amateurs who may wish to try crystal control of this oscillator can connect the crystal from control grid to ground in the 12AT7 tube, V_{1A} . Capacitor C_{21} (0.001-mfd) should be removed. Two crystals 3 kilocycles apart in frequency can be used if desired in the manner shown above.

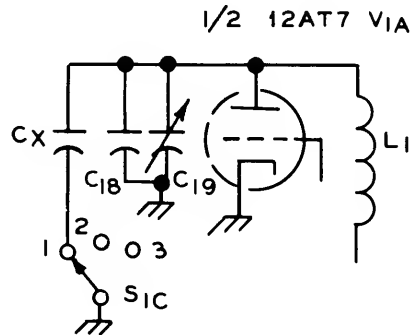

FIG. 5—DIAGRAM SHOWING CAPACITOR C_x AND EXTRA SWITCH ADDED TO OSCILLATOR IN SIGNAL SLICER. C_x IS 10 MMF AND SHOULD BE TRIED IN BOTH POSITIONS 1 AND 2 OF S_1C

PACKAGED SELECTIVITY

From March-April, 1957



Enjoy 1957-style selectivity and performance from your present receiver by plugging in this simple mechanical filter adapter that replaces the first IF amplifier tube.

—*Lighthouse Larry*

**455-KC
MECHANICAL
FILTER
RECEIVER
ADAPTER**

GENERAL INFORMATION

There are clear channels on today's crowded amateur bands even though you may not find them easily with your present communications receiver. Try tuning one of the new high-selectivity amateur receivers across a popular band and several clear channels usually will be found.

It is now possible to add this new order of selectivity to your present receiver—which otherwise may be quite satisfactory—by constructing a simple mechanical filter adapter unit that is substituted for the first 455-kilocycle intermediate-frequency amplifier tube (or the IF tube) without making any under-chassis changes in the receiver. Simply connect the adapter to a power source, remove an IF amplifier tube, and insert two short coaxial cables into the tube socket, as shown in Fig. 1. These cables carry the IF signal to and from the adapter, which may then be tucked away in an unoccupied corner of your receiver cabinet. An adapter that plugs directly into the tube socket could be constructed, but the available space is very restricted in many receivers.

The primary design and construction consideration of this adapter is to completely isolate the input and output circuits. Any stray coupling can cause signal leakage around the filter unit, thus impairing its effectiveness. For this reason, we recommend that the adapter be constructed as described.

Many modern medium-priced and older high-priced communications receivers now in general use are convenient to operate, have good frequency stability and sensitivity, but lack the necessary "skirt" selectivity to sufficiently reject strong signals that are only a few kilocycles higher or lower in frequency from a desired signal. The shaded area of curve "A" in Fig. 2 shows the typical selectivity characteristic of several popular medium-priced communications receivers. Although the peak, or "nose" of this curve is usually only a few kilocycles wide, the "skirt" selectivity 60 decibels down from the peak may be from 15 to 30 kilocycles broad! Small wonder that strong local signals a few kilocycles up the band from a station you are trying to copy may sometimes paralyze your receiver!

Incidentally, the curves at "A" are the bandwidth figures for a receiver with the selectivity control set for the sharpest bandwidth that does not utilize the crystal filter, if the receiver has one. Switching in the crystal filter will greatly sharpen the "nose" of the selectivity curve, but the width of the "skirts" may not be materially reduced.

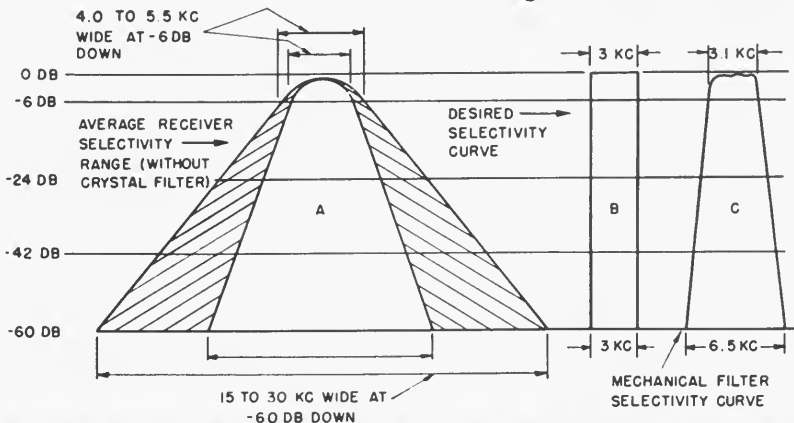

Fig. 2. Bandwidth curves showing: A—selectivity range of most medium-priced single-conversion receivers with crystal filter out of circuit; B—ideal selectivity curve for voice reception; and C—selectivity curve of a 455-kilocycle mechanical filter with a 3.1-kilocycle bandwidth.

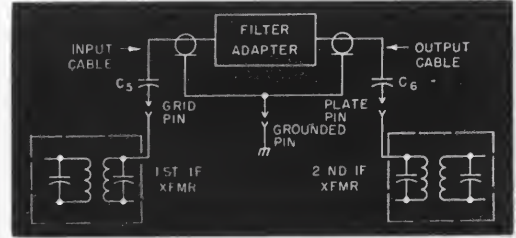

Fig. 1. Diagram showing how the mechanical filter adapter is connected to the first IF tube socket in the receiver.

When the "PACKAGED SELECTIVITY" adapter is installed in a receiver of this type, the crystal filter can then be utilized to reject, or "notch out" any heterodyne-type interference that may fall within the bandpass of the mechanical filter. Or, a "Q" multiplier may be connected into the receiver for this purpose. The mechanical filter has none of the characteristic "ringing" sound that sometimes results when a crystal filter is adjusted to produce an extremely sharp selectivity peak response curve. And lastly, the random noise output from the receiver will be reduced.

SELECTIVITY SYSTEMS

There are two systems generally used to obtain a bandpass characteristic that approaches the "ideal" communications receiver selectivity curve for voice-modulated signals, shown at "B" in Fig. 2. One system is the "packaged filter," including the mechanical filter as used in this adapter circuit, the crystal lattice filter, and certain toroidally-wound inductive filters. A good crystal lattice filter usually must be assembled from carefully matched war-surplus quartz crystals in this frequency range, while the toroidal filter operates at a lower frequency and requires a more complex frequency conversion adapter circuit.

The second method is to utilize a string of high "Q" circuits in the receiver's IF amplifier that are tuned to achieve the desired bandpass. This system can be space consuming, difficult to adjust and fairly expensive if quality components are employed.

Of the three packaged filters, the mechanical type has certain advantages. It is very compact, readily available in a variety of bandwidths, has an excellent selectivity curve, and is roughly equivalent in cost to the other systems having comparable selectivity. Curve "C" in Fig. 2 illustrates the selectivity of the 3.1-kilo-

PARTS LIST

C_1, C_4 —600-mmf ceramic (270- and 330-mmf in parallel).

C_2, C_3 —120-mmf ceramic.

C_5, C_6 —10-mmf tubular ceramic (Aerovox Type CI-1 or Erie Type 315).

FL_1 —455-kilocycle mechanical filter with 3.1-kilocycle bandwidth and 9-pin miniature plug-in base (Collins 455J-31).

L_1, L_2 —200-uh iron slug-tuned coil (Grayburne or Superex Vari-loopstick Model VL, or Miller No. 6300).

P_1 —male octal plug with retaining ring (Amphenol 86-PM-8).

V_1, V_2 —6BA6 or 6BJ6 tubes.

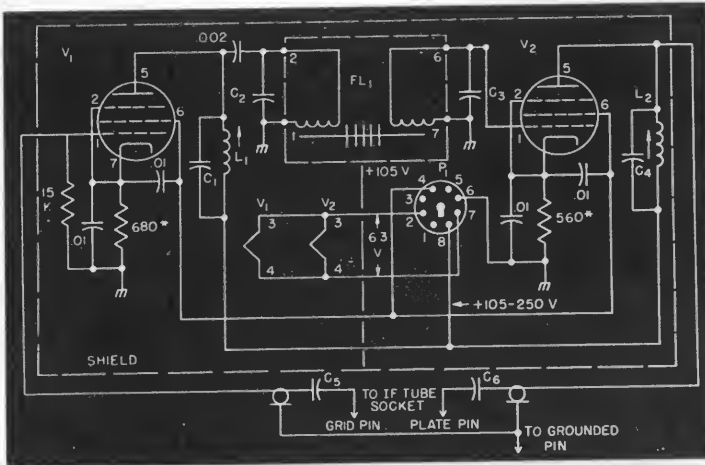

Fig. 3. Schematic diagram of the mechanical filter adapter.

cycle mechanical filter bandwidth suitable for AM and SSB reception. Compare this curve with "A," which is drawn to the same scale!

A mechanical filter is, as the name implies, a series of vibrating, mechanically resonant, disks tied together with small rods that transmit the vibrations from disk to disk. Small inductances coupled to the disks at both ends convert the electrical energy passing through them into mechanical vibrations at the input end and back into electrical energy at the output end. Each disk has a "Q" 20 times as high as an ordinary tuned circuit, so that several disks of slightly different resonant frequencies must be coupled together to achieve a nearly rectangular bandpass response curve.¹

Since the filter characteristic determines the overall intermediate frequency bandwidth, any other tuned circuits in the intermediate-frequency amplifier may utilize a low-cost, readily available coil, such as the vari-loopstick, instead of more expensive IF coupling transformers.

The adapter model pictured on the cover was assembled from parts that cost about five dollars (plus \$45.00 for the Collins F-455J-31 filter). W2FZW, designer of the adapter, was so pleased with his station receiver's new-found selectivity (formerly about 30 kilocycles broad at the -60-db points) after testing the adapter that he promptly added "A4" to the receiver's model number!

Receivers with an intermediate-frequency amplifier on 465 kilocycles (mostly found in pre-World War II receivers) must be re-aligned to the 455-kilocycle center frequency of the mechanical filter, otherwise very little signal will be heard when the adapter is added. This change in the intermediate frequency will render the crystal filter practically inoperative unless a 455-kilocycle filter crystal is substituted for the original.

ELECTRICAL DETAILS

The adapter picks up the signal from the control grid of the receiver's first IF amplifier tube socket through coupling capacitor C_5 , then feeds it to the grid of a pentode tube, V_1 , in the adapter unit, as shown in the schematic diagram, Fig. 3. The plate circuit of V_1 is capacity-coupled to the input terminals on the mechanical filter to keep plate current from flowing through this coil. A much wider signal voltage range can be handled by the filter without distortion when no current flows through the coils. Both filter coils are tuned to resonance at the operating frequency by fixed capacitors C_2 and C_3 .

¹A comprehensive discussion of mechanical filters may be found in the following articles: QST magazine, "Mechanical Bandpass Filters for IF Ranges," February, 1953, page 22; Proceedings of the IRE, January, 1957, page 5; and in Collins Application Bulletin No. 200.

The filter output terminals are connected directly to the control grid of V_2 and the chassis, since no grid current will flow in this stage. The output signal from V_2 is again capacity coupled back into the plate terminal of the receiver's IF tube socket. The tuned circuits connected to the plates of both V_1 and V_2 are composed of vari-loopstick coils, L_1 and L_2 , shunted by fixed capacitors C_1 and C_4 .

The input and output coaxial cables are 16-inch lengths of RG-58/U. This cable forms the 40-mmf ground leg of a capacitor voltage divider, C_5 being the other leg, that reduces the signal voltage applied to V_1 to about $\frac{1}{4}$ of the voltage across the secondary of the receiver's first IF transformer.

The over-all signal amplification of the adapter has been held down to a few decibels more than the 10-db loss through the filter through use of small input and output coupling capacitors and fairly large cathode bias resistors in both amplifier stages. This is suitable for receivers having two or more intermediate-frequency amplifier stages, but additional gain from the adapter may be obtained by reducing the value of one or both cathode resistors to 270 ohms. This may be desirable when the adapter is operated with a receiver having only one intermediate frequency amplifier stage. The capacity ratio in the input voltage divider may be reduced by shortening the input cable, or increasing C_5 to 25 mmf, for a further increase in gain, but the first IF transformer in the receiver may then have to be retuned to achieve maximum signal.

Power was brought into this unit through a male octal chassis plug, but a three- or four-wire cable may be substituted. The pin connections were made as shown so that this adapter could be plugged directly into the "NBFM" adapter socket on certain National receiver models. Most communications receivers have an accessory power socket on the rear of the chassis from which power may be obtained. If 6BJ6 tubes are used for V_1 and V_2 , the power required (6.3 volts at 0.3 amperes, and 105 to 250 volts at 10 ma) may be

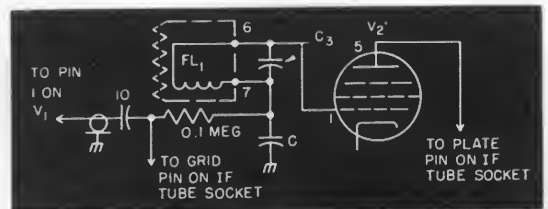

Fig. 4. Alternate output coupling and optional AVC connections in the adapter.

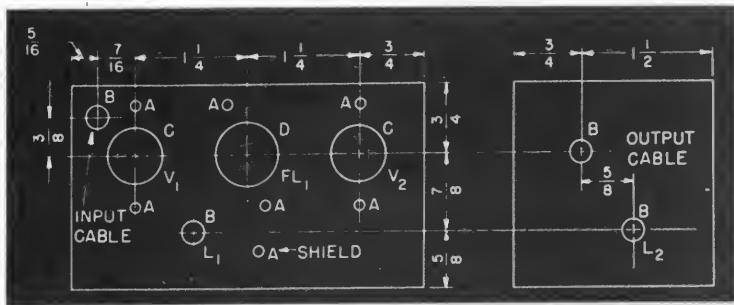

Fig. 5. Suggested parts layout for the adapter.

little more than was drawn by the IF tube replaced by the adapter. A single plate and screen voltage lead will suffice when the supply voltage is 130 or less. A single 250-volt DC source will require that an 18,000-ohm, 12-watt screen voltage dropping resistor be connected between pins 4 and 8 on the power plug.

An alternate output coupling circuit, and a method of applying AVC voltage from the receiver to the second amplifier stage in the adapter are shown in Fig. 4. This circuit is mainly useful when the adapter is connected to a receiver that has few AVC-controlled stages. The AVC voltage is taken from the control grid connection on the IF tube socket and is applied to the grid of V_2 through the output coupling coil of the mechanical filter. The lead from the plate of V_2 to the IF tube socket should be the shortest possible length of RG-59/U coaxial cable. The primary of the receiver's second IF transformer should be returned after plugging in this cable.

MECHANICAL DETAILS

This adapter unit was constructed in a $2\frac{1}{4}$ x $2\frac{1}{4}$ x 4-inch Minibox (Bud CU-3003), a good compromise that is compact, yet not too small for easy wiring. A larger box may be required if a "B" or "C" type rectangular mechanical case filter designed for horizontal mounting is used instead of the "J" model. A somewhat smaller Minibox will suffice if the circuit in Fig. 4, eliminating L_2 , is used.

For maximum isolation between input and output circuits, a parts layout similar to that shown in the drilling diagram, Fig. 5, should be followed. After

DRILLING LEGEND

- "A"—No. 32-drill for socket and shield
- "B"— $\frac{9}{32}$ -inch-diameter drill
- "C"— $\frac{5}{8}$ -inch-diameter socket punch
- "D"— $\frac{3}{4}$ -inch-diameter socket punch

drilling and punching all holes, the tube and mechanical filter sockets, power plug and rubber grommets may be assembled. Solder lugs were placed on all socket screws for ground connections. Then, a 3-x 3-inch piece of perforated sheet aluminum is formed into the shield shown in the bottom and oblique views, Figs. 6 and 7, respectively. A $\frac{3}{8}$ -inch-wide flange is formed along all edges of this shield except where it crosses the center of the 9-pin socket. A small notch is cut in the shield next to the socket for heater and plate power leads to V_2 . The shield passes between the lugs for pins 3 and 4, and 8 and 9, then is bolted to a soldering lug that has been soldered to pin 2 on the socket. The upper flange on the shield also is bolted to the box directly above L_2 , and two self-tapping screws are driven into the shield's side flanges when the other half of the box is assembled.

Assembling the two IF tube socket probes takes little more time than is required to explain it. First, cut two lengths of RG-58/U coaxial cable 17 inches long and remove $1\frac{1}{2}$ inches of the vinyl cover on one end of each piece. Slide the braided shield back over the outer cover, then trim the center conductor and insulation so that $\frac{1}{2}$ inch protrudes beyond the shield. Next, skin the insulation to expose $\frac{1}{4}$ inch of the center conductor, trim one lead of the 10-mmf capacitor, C_6 , and solder it to the center conductor with a $\frac{5}{16}$ of an inch overlap. Cut narrow strips of plastic insulating tape and wrap them around this joint up to the body diameter of the capacitor as shown in Fig. 8.

Slide the braided shield over the capacitor, pull it

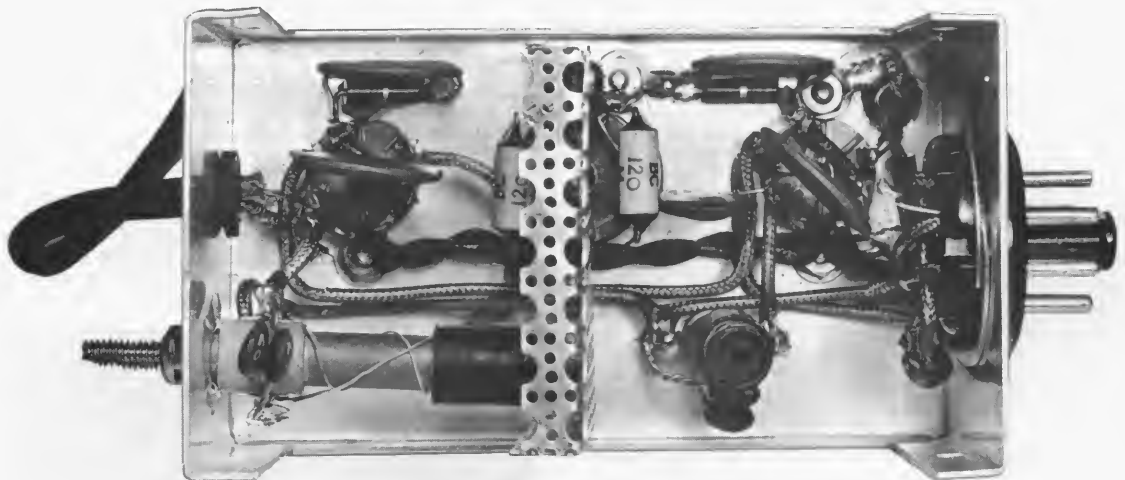

Fig. 6. Bottom view of the adapter showing locations of major parts.

carrier strength on the meter. On a receiver that has no "S" meter; L_1 and L_2 are best adjusted by turning the RF gain down, the audio gain up, and tuning both coils for maximum audio output from a modulated signal. Tuning adjustments on the first and second IF transformers in the receiver also may be touched up for highest output, although no improvement in gain may be noted if C_5 and C_6 are only 10 mmf.

TUNING TIPS

A somewhat different technique should be used for tuning AM and SSB signals on a receiver following installation of "PACKAGED SELECTIVITY." If any of your local hams have a receiver with built-in mechanical filters, you may wish to have him brief you on this subject. And it's also a good opportunity to compare the selectivity improvement you can expect from this adapter.

Modulated signals with carrier should be tuned in so that the carrier is placed on one edge, rather than the center of the IF passband shown in Fig. 1C. If you tune a bit too far, the carrier will drop off the edge and will be suppressed, and the modulation will sound like an SSB signal—practically unintelligible. Since only one sideband of a double-sideband signal will be heard at a time, the receiver tuning may be shifted so that the sideband on which a heterodyne is present may be "pushed off" the edge of the IF bandpass.

When receiving single-sideband, suppressed carrier signals—or for single-signal CW reception—the receiver's beat frequency oscillator is turned on and the "PITCH CONTROL" is adjusted so that the BFO carrier is near one edge of the IF passband. The proper pitch control setting may be determined by tuning the receiver across a carrier while adjusting the pitch control so that a beat note on only one side of zero beat is heard. After noting or marking this setting of the pitch control, again turn it so that the test signal on only the other side of zero beat is heard. Note this setting, then try tuning in an amateur SSB signal. If intelligible speech cannot be heard, shift the BFO pitch control to the first-noted setting and again carefully tune the receiver. Intelligible speech should now be heard.

As with the reception of 'phone signals with carrier, some interference can be removed from an SSB signal by shifting the BFO pitch control a small amount, then retuning the receiver so that the correct voice pitch is again heard.

This adapter will serve as a good signal slicer for SSB reception, especially if your receiver has strong BFO injection to the second detector circuit. When the usual diode second detector is replaced by a product detector, which can also be constructed as a plug-in adapter, a wide range of SSB signal strengths can be handled by the receiver without continually turning the RF gain control up and down. (See "CQ" magazine, November, 1956, page 19; and the ARRL's "Single Sideband for the Radio Amateur," page 86, for additional details on product detectors.)

In addition to the 3.1-kilocycle bandwidth filter previously mentioned, 455-kilocycle plug-in filters may be obtained in the following bandwidths: 0.5, 1.5, 2.1, 4.0, 6.0 and 12.0 kilocycles at the -6 db points.

The 2.1-kilocycle bandwidth model is ideal for reception of SSB and exalted-carrier reception of AM signals. The 0.5-kilocycle bandwidth model provides just about the maximum selectivity that is practical for CW reception. Devoted brass pounders may prefer this bandwidth, especially during DX and other contests. Samples of the 0.5- and 2.1-kilocycle filters were tested simply by plugging them into this adapter. The same shunting capacitors, C_2 and C_3 , may be used with both filters.

If you still have a soft spot in your heart for that old receiver, enjoy 1957 selectivity from it by installing "PACKAGED SELECTIVITY" that meets your bandwidth needs.

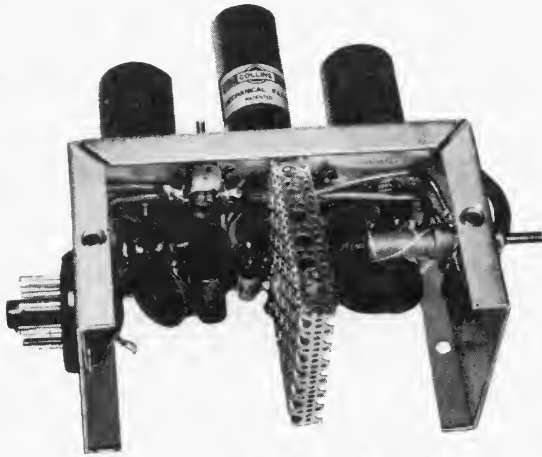

Fig. 7. Oblique view of the adapter.

- tight and wrap a short length of tinned copper wire twice around the middle of the capacitor. Solder the wire to the shield and trim off the excess shielding. The tinned wires from each cable are then soldered to a pin from an octal tube base for a plug-in ground connection. Similar pins are also soldered to the capacitor leads, and the excess lead trimmed off. The exposed cable shield is then wrapped with plastic tape.

- Capacitors C_5 and C_3 also may be soldered directly to a male octal plug, if desired, instead of making individual pin connections. If the receiver has a 7-pin miniature tube in the first IF amplifier, short lengths of No. 18 tinned wire may be used for the plug-in pins on the cables, or the capacitors and ground lead may be soldered to a special 7-pin miniature male adapter plug (Vector No. P-7).

- For easy parts assembly, the shield may be temporarily removed, and replaced when wiring is completed. Heater, screen and plate power wires are next installed, keeping all such leads close to the box wherever possible to minimize stray signal pickup. Small parts, resistors and capacitors, are now soldered in place, after which the coaxial cable input and output leads are connected. About $\frac{5}{8}$ of an inch of the outer vinyl jacket is skinned from these cables and the shield braid is twisted into a single conductor. These cable ends are then brought into the box through rubber grommeted holes. The cable shield is soldered to the closest ground lug and the center conductors are soldered to the correct tube socket pins. Finally, the vari-loopstick coils and capacitors C_1 and C_4 are assembled and wired.

OPERATION

- The adapter is connected to a communications receiver as previously described, following a wiring and power check to insure that the correct voltages are applied to the various tube elements. The receiver should then be tuned to the center of a strong, steady local amateur or broadcast station signal. If the receiver has an "S" meter, the AVC may be left "ON" while tuning the slugs in coils L_1 and L_2 for maximum

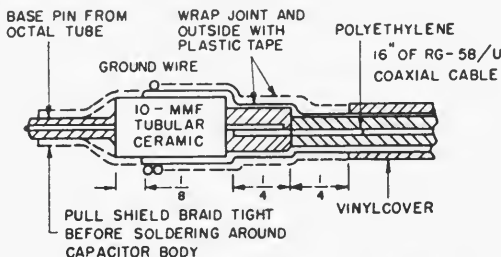

Fig. 8. Cross-section assembly view of signal cables.

MOBILE SSB RECEPTION

MOBILE SSB RECEPTION . . .

Successful reception of single and double sideband signals in a mobile radio system requires that the receiver have excellent frequency stability, on the order of cycles at several megacycles. Also, sufficient selectivity to attenuate signals on adjacent channels is highly desirable.

The double conversion superhetrodyne receiver circuit, when properly applied, will meet both of these major requirements. It makes possible using crystal control in the high frequency oscillator for the first frequency converter when a band only a few hundred kilocycles wide — such as an amateur band — will be tuned by the receiver.

The tunable portion of the receiver can then be operated much lower in frequency where tunable oscillators for the second converter can easily be built with a stability within a hundred cycles. Some top-performing amateur radio receivers utilize this principle.

The double conversion receiver principle has been applied by W8DLD and W8WFH to attain excellent stability and selectivity at low cost by using the BC-453 Command Set receiver, covering 190 to 550 kilocycles, as a tunable i.f. amplifier preceded by high-frequency converters with crystal-controlled oscillators. The selectivity and stability of the BC-453 are widely recognized in amateur radio circles.

The tunable oscillator in the BC-453 oper-

CRYSTAL FREQUENCY CHART

CRYSTAL FREQ. (MC)	HARMONIC	INJECTION FREQ. (MC)	BAND TUNED (MC)	BC-453 RANGE (MC)
3.2	Fund.	3.2	3.5- 3.85	0.2-0.55
3.5	Fund.	3.5	3.7- 4.0	0.2-0.5
6.8	Fund.	6.8	7.0- 7.3	0.2-0.5
6.9	2nd	13.8	14.0-14.35	0.2-0.55
4.6	3rd	13.8	14.0-14.35	0.2-0.55
6.933	3rd	20.8	21.0-21.35	0.2-0.55
5.2	4th	20.8	21.0-21.35	0.2-0.55
6.967	3rd	20.9	21.1-21.45	0.2-0.55
5.225	4th	20.9	21.1-21.45	0.2-0.55
6.975	4th	27.8	28.0-28.35	0.2-0.55
7.0	4th	28.0	28.2-28.55	0.2-0.55
7.075	4th	28.3	28.5-28.85	0.2-0.55
7.15	4th	28.6	28.8-29.15	0.2-0.55
7.225	4th	28.9	29.1-29.45	0.2-0.55
7.3	4th	29.2	29.4-29.75	0.2-0.55

ates sufficiently low in frequency, and is mechanically rugged, to minimize the effects of temperature and power supply voltage variation, and shock and vibration upon its stability. Of course, the crystal-controlled oscillators in the amateur band converters have excellent stability too.

Incidentally, here is a more complete listing of crystal frequencies which can be used in the converters described herein than the crystals covered in the coil tables. The listing also shows the harmonic of the crystal oscillator required for injection to the mixer, the signal frequency ranges covered, and the tuning range of the BC-453 receiver for each crystal.

The BC-453 receiver will work fine with 150 volts on the plates. If 300 or more plate volts are applied, bypass capacitors may fail. W8DLD suggests using a VR-150 or 0A2 regulator tube to hold the plate voltage down to 150 volts. Use a power supply with at least 200 volts output and drop the voltage with a 10-watt adjustable resistor, set so that the VR tube is ignited at all times.

Try the converter/BC-453 receiving combination described in this issue. I'm sure you'll be pleased with its performance.

W8WFH's bandswitching converter, and the metering panel and power control box, all form a neat under-dash package in the above view. The tuning dial on the converter actually tunes the BC-453 receiver—tucked up on the firewall at the right side of the car—through a flexible shaft.



BANDSWITCHING MOBILE CONVERTER · From September-October, 1960

By W. C. Louden, W8WFH

MOBILE OPERATION on several amateur bands requires that the transmitting and receiving equipment in the installation—as well as the antenna—be constructed to be switched readily to the band on which operation is desired at a particular time. A band-switching converter with crystal controlled oscillator, designed to work into a receiver covering an established intermediate frequency tuning range, can be constructed in little more space than is needed to house a converter covering only a single band.

The converter used at W8WFH/M, however, also incorporates a remote tuning dial which simply drives a flexible shaft coupled to the receiver, mounted up under the right

side of the dash in the car. Other controls for the i.f. receiver — r.f. gain, audio gain, AVC switch, and sideband selector switch — also were built into the converter, although these controls and the dial could easily have been located elsewhere.

SEPARATE COILS were used in each of the r.f. circuits of the converter shown in the schematic diagram, Fig. 1, to cover the five amateur bands from 3.5 to 30 megacycles. A 6CB6 sharp cutoff r.f. pentode functions as the r.f. amplifier, while the pentode section of a 6U8 (or 6U8-A) is the mixer. The triode 6U8 section is the crystal oscillator.

(continued on page 4)

TABLE I — PARTS LIST — BANDSWITCHING CONVERTER

C ₁	5-35 mmf midget air variable.	RFC ₁	0.5 millihenry pi-wound r.f. choke.
C ₂	5-140 mmf midget mica padder.	RFC ₂	2.5 millihenry pi-wound r.f. choke, tapped between first and second pies.
J ₁ , J ₂	auto radio type antenna connectors; or, midget phono jacks.	S ₁	(S _{1A} to S _{1E}) 5-pole, 5-position, 5-section midget rotary tap switch.
L ₁ to L ₄	r.f., mixer and oscillator coils on CTC LS-6 iron slug-tuned coil forms; see COIL TABLE for details on windings.	S ₂ , S ₃ , S ₄	1-pole, 2-position midget slide switches.
		X ₁	Quartz frequency control crystals, 5 required; see COIL TABLE for frequencies.

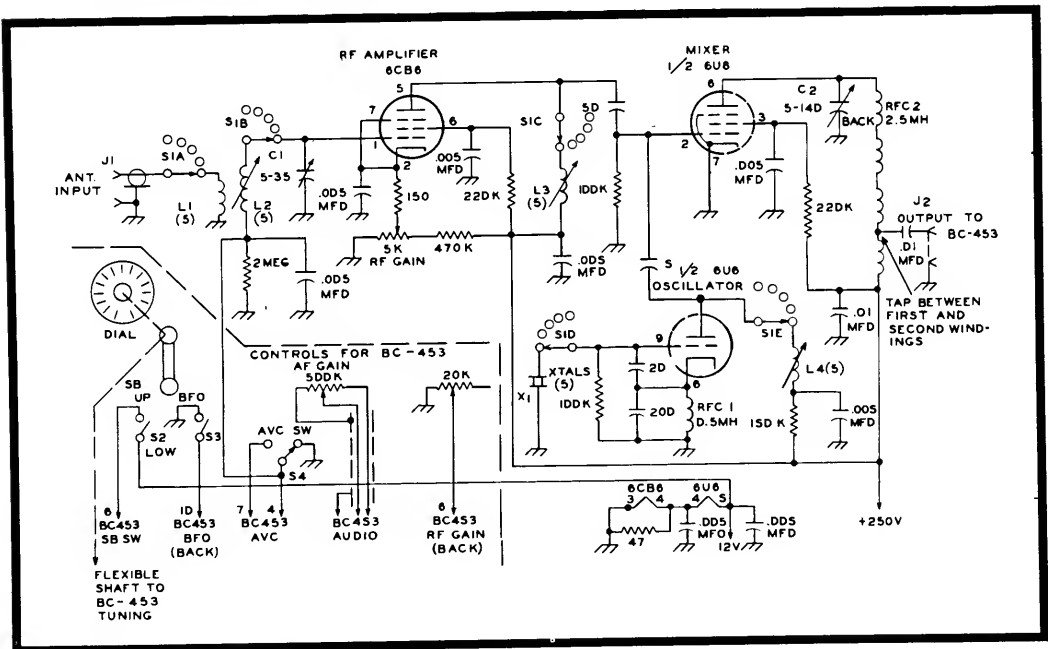

FIG. 1. SCHEMATIC DIAGRAM of the bandswitching mobile converter constructed by W8WFH. All resistances are in ohms, 1/2-watt rating, and capacitances are in micro-microfarads (mmf), unless otherwise marked. All controls at the lower left corner are for

the BC-453 receiver with which this converter is used. Only one set of coils is shown for L₁, L₂, L₃ and L₄; actually there are five coils in each of these locations, each connected to a separate position on S_{1A} to S_{1E}.



PANEL VIEW PHOTO of the bondswitching converter. Only the controls marked "RF GAIN," "ANT.," and "80-40-20-15-10" (the bandswitch) actually control circuits in the converter.

(continued from page 3)

The crystal oscillator functions at the crystal fundamental frequencies to cover the 3.65-4.0 and 7.0-7.3 tuning ranges, as shown in TABLE II—COIL TABLE. For 14.0-14.35 megacycles, the second harmonic (13 megacycles) of the 6.9-megacycle crystal is the injection frequency, while the fourth harmonic of a 5.25-megacycle crystal (21.0 megacycles) is used to cover 21.10-21.45 megacycles. Five crystals in the range of 6.95 to 7.2875 megacycles are required for complete coverage of the 28-megacycle band. However, the fourth harmonic (28.3 megacycles) of a 7.075-megacycle crystal will give coverage of 28.5 to 28.85 megacycles where most side-band operation occurs on this band. Other crystal combinations are suggested in

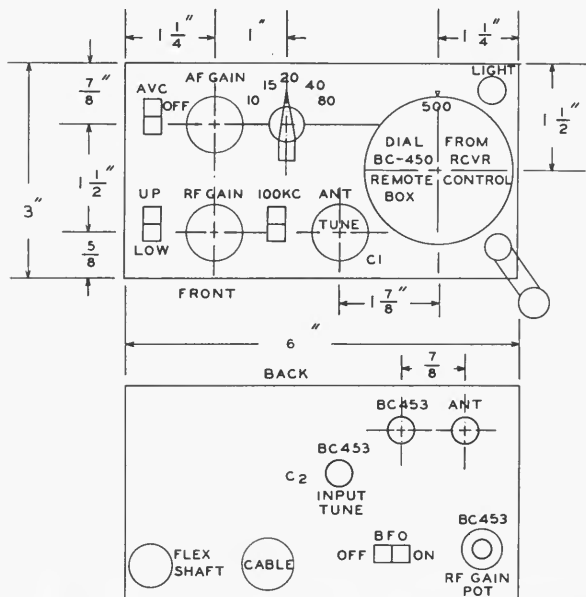

FIG. 2. FRONT AND REAR panel drilling diagrams for the bondswitching converter. The slide switch marked "100 KC" applies plate voltage to a 100-kilocycle crystal calibrator which the author included in his converter, but is not shown in the schematic diagram, Fig. 1. All the BC-453 controls could be mounted on a separate panel to reduce crowding in the converter, if desired.

TABLE II — COIL TABLE — BANDSWITCHING CONVERTER

AMATEUR BAND (MC)	CRYSTAL FREQ. (MC)	INJECTION FREQ. (MC)	COILS (inductance in uh and CTC Part No.)			
			L ₁ (turns)	L ₂	L ₃	L ₄
7	3.5	3.5	10 of #30 enam.	16-30 + 30* (X2060-5)	61-122 (X2060-7)	61-122 (X2060-7)
7	6.8	6.8	7 of #30 enam.	10-18 (X2060-4)	16-30 + 30* (X2060-5)	28-63 (X2060-6)
14	6.9	13.8	5 of #30 enam.	3.4-7.0 (X2060-2)	3.4-7.0 + 10* (X2060-2)	16-30 (X2060-5)
21	5.25	21.0	3 of #30 enam.	2.0-3.7 (X2060-1)	2.0-3.7 (X2060-1)	2.0-3.7 (X2060-1)
28	7.075	28.3	2 of #30 enam.	17 turns of #24 enam.	22 turns of #26 enam.	22 turns of #26 enam.

(Wind 28-MC coils on CTC LS-6 Forms)

*Small ceramic capacitor across coil where indicated — otherwise only circuit capacitance.

TOP VIEW PHOTO of the band-switching converter model. The 100-kilocycle crystal calibrator components are fastened to the small angle bracket in the upper portion of this view. The band-switch was built up from a Centralab midget tap switch index assembly (PA-302), and five switch wafers (PA-31). Although this 6 x 6 x 3-inch box was fabricated by the author, the converter can easily be housed in a 7 x 5 x 3-inch Minibox if the BC-453 controls are not included.

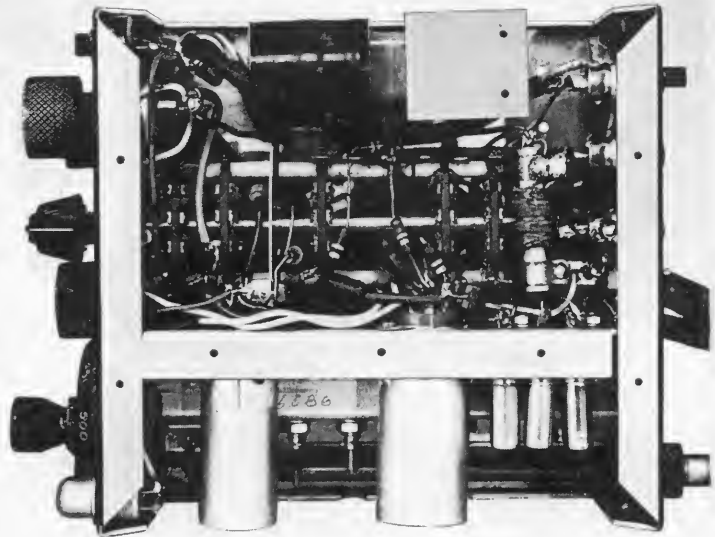

the **CRYSTAL FREQUENCY CHART** for the converters on page 2 of this issue. Oscillator coils (L₁) tune to the crystal harmonic frequency being used.

A 2.5-millihenry r.f. choke, tapped between the first and second pies from the end to which plate voltage is applied, serves as the converter output circuit and is peaked at the desired frequency in the 190 to 550-kilocycle tuning range of the BC-453 receiver with C₂. An alternate output circuit, shown in Fig. 2 of the single band converter article on page 8, also is suitable for this converter.

CONSTRUCTION of the model shown in the photos was accomplished in a 6 x 6 x 3-inch home-fabricated box made in two sections. However, the converter can be constructed into a 7 x 5 x 3-inch Minibox (Bud CU-3008) if the remote tuning dial and BC-453 controls are not included in the box. Or, these controls can be included when the converter is constructed in a Minibox 8 x 6 x 3½ inches (Bud CU-3009) in size.

Dimensions are given in the panel layout diagram, Fig. 2, the box layout diagram, Fig. 3, and the subchassis layout diagram, Fig. 4, for the 6 x 6 x 3-inch box, but will serve as a guide for the larger standard Miniboxes suggested above. It is best to select the box size to fit into the space available in each individual mobile installation.

Major parts were mounted in the locations shown in the above diagrams, and should be kept in the same relative positions in the larger boxes. The subchassis has a ½-inch step, as shown in the side view, and was made with narrow flanges along the upper, lower and rear edges to facilitate rigid mounting.

Wiring should be handled in the usual manner for high-frequency circuits: Shortest possible grid, plate and coil leads; disc ceramic bypass capacitors soldered with shortest possible leads; power wiring run well away from r.f. coils; and short lengths of coaxial cable for the antenna input and output connections to the BC-453 receiver.

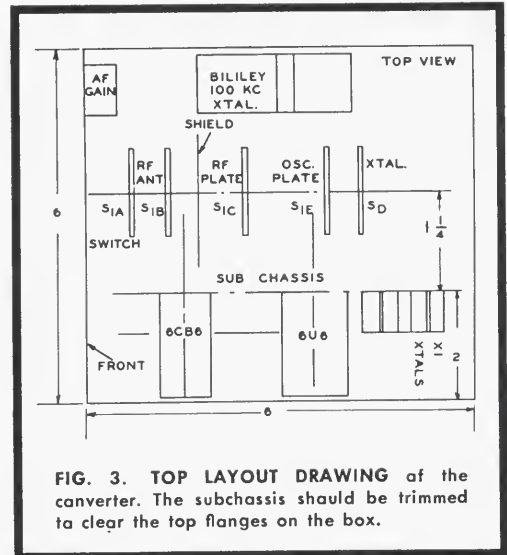

FIG. 3. TOP LAYOUT DRAWING of the converter. The subchassis should be trimmed to clear the top flanges on the box.

THE TUNEUP PROCEDURE is quite simple, once construction is completed and a check has been made of the heater and plate power circuits to ensure that the correct voltages appear on both tubes. Plate voltages will be the same as the power supply voltage, and screen voltages will range from 100 to 120 volts on both the 6CB6 and 6U8 tubes.

The crystal oscillator should be adjusted first. A general coverage receiver is helpful in checking to see that the oscillator works on all bands, and that the plate coils (L₁) are tuned to the correct harmonic frequency. Set S₁ to the 3.5-megacycle position, tune the receiver to 3.5 megacycles, and tune the 3.5-megacycle L₁ for maximum signal in the receiver.

Next, switch S₁ to 7 megacycles, set the receiver at 6.8 megacycles and tune the 7-megacycle L₁ for maximum signal. For 14

(continued on page 6)

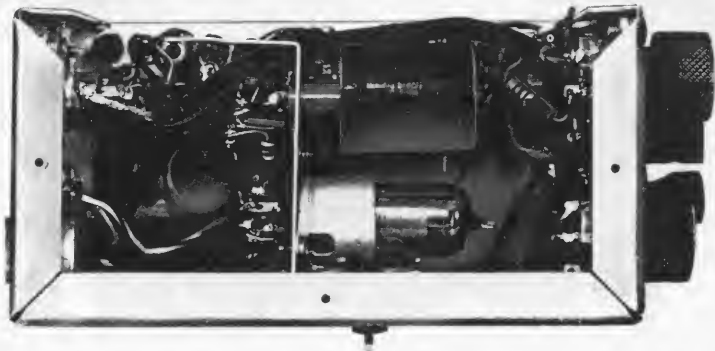

PHOTO SHOWING LEFT side of the converter. The crystal calibrator components—tube, crystal, tuning capacitor (extending out bottom) and angle bracket—are in the center. Flanges on box are $\frac{3}{8}$ of an inch wide.

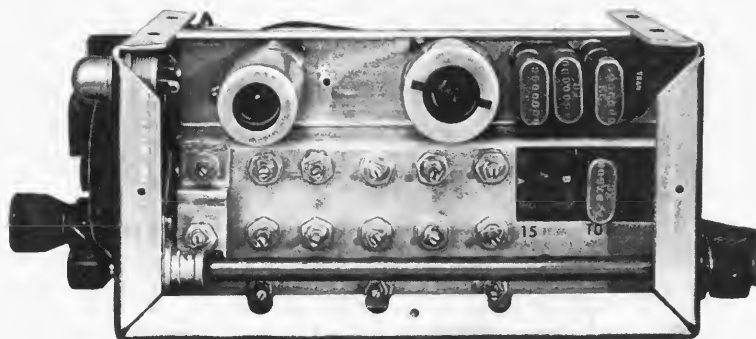

PHOTO SHOWING RIGHT side of the converter, with some crystals (X_1) removed to show double crystal sockets. Positions of the coils on the subchassis are shown in Fig. 4. The remote tuning diol shaft runs back through the converter just below the coils.

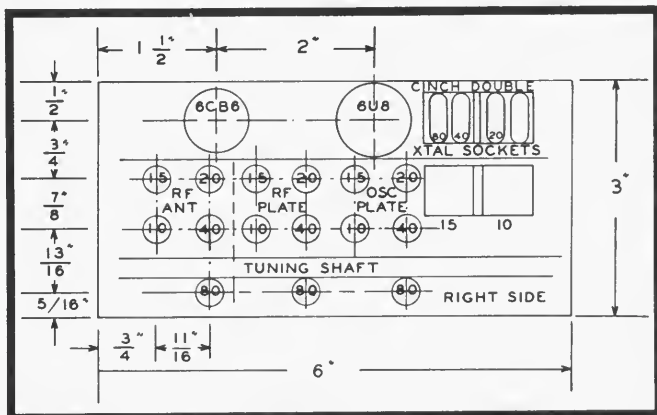

FIG. 4. LAYOUT DIAGRAM for the converter subchassis on which the tube sockets, coils and crystal sockets are mounted. Holes not marked for location and size should be drilled to suit the components used. The subchassis has a $\frac{1}{2}$ -inch step between the coils and tube sockets.

(continued from page 5)

megacycles, set S_1 , tune the receiver to 13.8 megacycles, and tune the 14-megacycle L_1 for maximum signal. For 21 and 28 megacycles, calculate the correct harmonic frequency of the crystal being used, set the receiver at that frequency, and peak the proper L_1 coils.

FRONT-END ALIGNMENT consists simply of peaking the mixer grid (L_3) and r.f. amplifier grid (L_1 - L_2) coils at the center of the tuning range for each band. The converter output should, of course, be connected to the BC-453 receiver, and a signal generator — or amateur band signals from an external antenna — should be fed into the converter input, J.

Set the BC-453 receiver at about 350 kilocycles and set C_1 —the r.f. stage grid peaking

capacitor — at mid-capacitance. Tune the mixer grid coils (L_3) first for maximum signal at these frequencies, and then peak the r.f. coils (L_1 - L_2) for each band. Either the signal generator, or external signals close to the specified frequencies, may be used.

The alignment may be completed before the converter is "buttoned up" by installing the top half of the box, since the coils are sufficiently removed from it to have little effect on the inductance values.

Both converter power and remote control connections were made through a 12-pin plug and cable running to the BC-453 receiver. Length of this cable, and the flexible shaft for tuning, will be determined by the space available in the constructor's car, and probably will be from 24 to 36 inches long.

TABLE II — COIL TABLE — SINGLE-BAND CONVERTERS		
AMATEUR BAND (MC)	PART NO. (MERIT)	ALTERATIONS TO BE PERFORMED ON COILS L ₁ TO L ₅ , INCLUSIVE
4	TV-108 (4.5-MC TV IF)	Remove coils from forms. Replace with single pies (same position) from 2.5-mh. r.f. choke. Remove turns from inside of pies until coils fit on forms at original coil positions. Remove more turns until circuits tune to 4.3 MC with slug out and 25-mmf capacitors across each coil in place of original capacitors.
7	TV-108	Remove 50-mmf capacitors across TV-108 coils and replace with 20-mmf capacitors. Remove turns from original coils until each circuit tunes to 7.5 MC with slug all the way out.
14	FM-251 (10.5-MC FM IF)	Turn slugs nearly all the way out of coils and remove turns from each coil until each circuit tunes to 14.8 MC. Use original capacitors across coils.
21	TV-104 (21-MC TV IF)	No alterations required in either coils or capacitors. Tune each circuit to 21-MC band to achieve proper bandpass.
28	TV-104	Turn slugs nearly all the way out of coils and remove turns from each coil until each circuit tunes to 30 MC.

(continued from page 7)

The second pair of coils, L₃ and L₄, couple the signal into the pentode section of a second 6U8, operating as a mixer. The triode section of this tube is the crystal oscillator, operating either on the fundamental or harmonics of the crystal, as described in the bandswitching converter. Oscillator signal injection is through a small coupling capacitor. Values from 2 to 5 mmf should be tried, to obtain optimum oscillator injection.

Plate circuit of the mixer is again a 2.5-millihenry r.f. choke (RFC₂), with the i.f. output signal tapped off between the first and second pies. An optional mixer output circuit, using a Miller No. 70-A broadcast receiver antenna coupling coil, is shown in Fig. 2. The antenna winding is used for the output link to the power plug, P₁.

THE CHASSIS on which all converters were constructed is a 5 1/4 x 3 x 2 1/8-inch Minibox (Bud CU-3006) and provides plenty of room

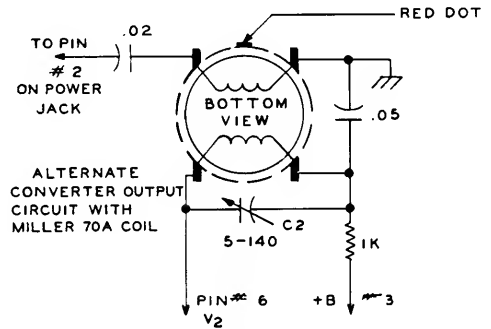

FIG. 2. OPTIONAL OUTPUT CIRCUIT for the converters, using a Miller 70A miniature broadcast receiver antenna coil with the primary as the output link coil. This circuit can be substituted for RFC₂ in either the bandswitching or single-band converters.

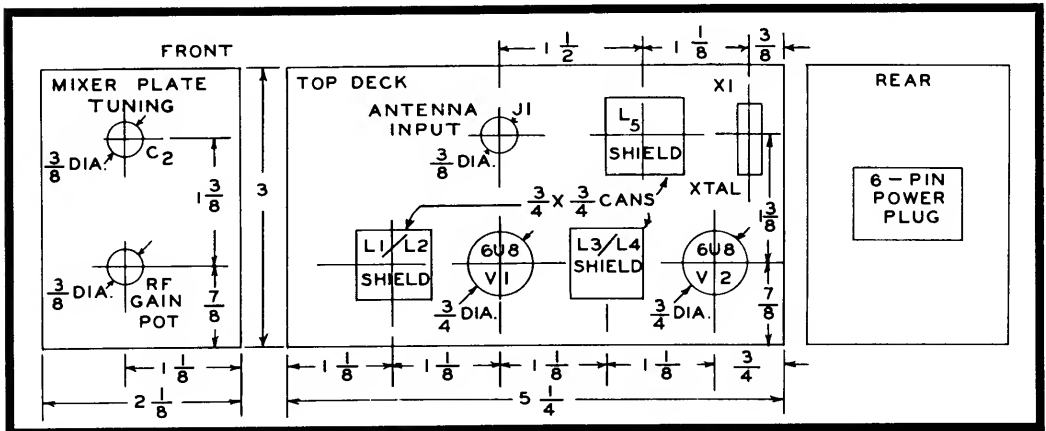
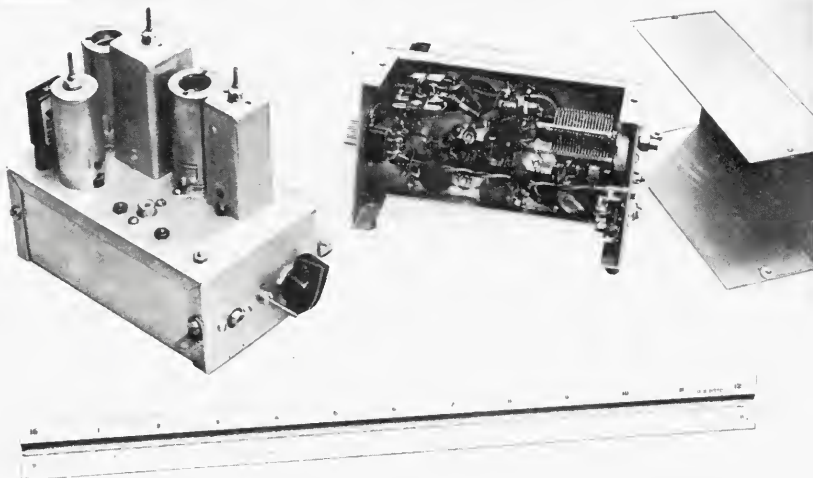

FIG. 3. CHASSIS LAYOUT DIAGRAM for the single-band converters. The chassis is a 5 1/4 x 3 x 2 1/8-

inch Minibox (Bud CU-3006). The same parts layout was used for all five of W8DLD's converters.

SINGLE-BAND converter views, with completely assembled model at left, and model with bottom cover removed at right. Placing all tuned circuits in shields above the chassis reduces interaction and leaves plenty of room for small components under the chassis.



COMPLETE RECEIVER, composed of BC-453, modified as described on pages 10 and 11, and the crystal controlled converter mounted on the top shield (at left). Rear view of right shows audio amplifier constructed on small plate, occupying space in which dynamotor mounts on original receiver.

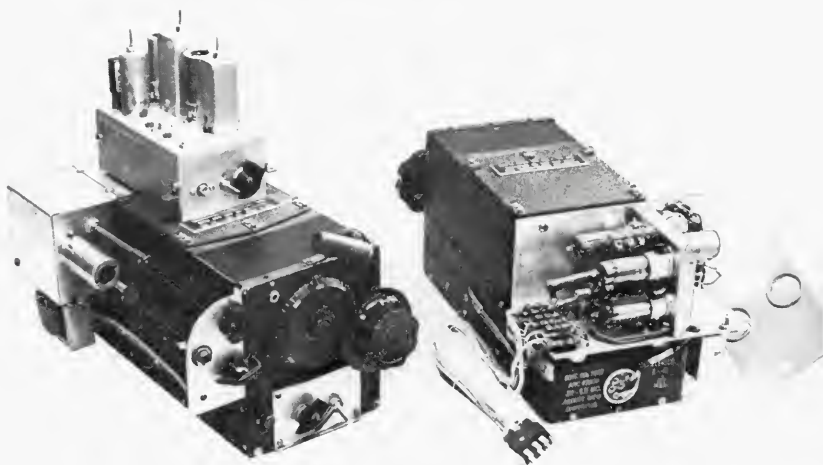

for the components specified in TABLE I—PARTS LIST. The same general parts layout, shown in the drilling diagram, Fig. 3, was used for all converters.

The alterations necessary on coils L_1 through L_5 — as described in TABLE II — COIL TABLE, and the coils checked for proper frequency coverage with a grid-dip oscillator — should be made before the shield cans are fastened to the chassis.

The usual precautions regarding short r.f. wiring and bypass capacitor leads apply to all converters, and especially the 21 and 28-megacycle models. The tube heaters may be operated from either a 6 or 12-volt supply by making the proper connections when wiring the Jones cable jack which connects to P.

ALIGNMENT of the crystal oscillator stage consists simply of peaking L_5 for maximum signal in a receiver tuned to the proper harmonic frequency for the crystal and band in use. After coupling the BC-453 receiver to the output, and feeding in a signal of the proper frequency into J_1 , the signal circuits, L_1 to L_4 , may be aligned. Peak coils L_2 and L_4 (the bottom adjustments) about 50 kilocycles inside the high edge of the amateur band for which the converter is designed (3.95 megacycles on the 4-megacycle converter). Peak coils L_1 and L_3 from 100 to 200 kilo-

cycles lower in frequency, so that the converter has nearly uniform gain across the portion of the amateur band most used. Coils L_1 and L_3 are made the top adjustments so that the converter bandpass can be easily changed for maximum performance either in the American phone, or CW assignments of the amateur bands.

The converters, when completed and aligned, may be mounted on top of the BC-453 receiver, as shown in the picture above.

At W8DLD/Mobile, the converters were mounted on top of the linear amplifier for the sideband transmitter in the rear of the station wagon (as shown in the view on the top left corner of page 7 in the July-August, 1960 issue). This permits a short connection to the antenna changeover relay — also on the linear amplifier — and changing converters when bands are switched in the amplifier. A coaxial cable feeds the i.f. output signal from the converter to the BC-453 receiver, mounted below the dash (see picture on page 4 of the July-August, 1960 issue).

Converters of this type have traveled over 120,000 miles in W8DLD's mobile installations, and the models described incorporate the lessons learned during this vast amount of "field testing."

By A. F. Prescott, W8DL D, and W. C. Loudon, W8WFH

CONVERSION DATA for the BC-453 Command Set Receiver has been widely published. However, here are suggestions for making the basic conversion, plus adding a more powerful audio amplifier, fast-acting AVC and S-meter circuit, and a sideband selector switch.

HEATER CIRCUIT—

To operate the BC-453 tube heaters from a 6-volt supply, rewire all heater connections to the sockets in parallel. Install 6-volt tubes: three 6SK7's, one 6K8, one 6SR7, and one 6J5 or 6C5 in the audio (V8), changing no socket connections other than tying pin 7 to pin 1.

For 12-volt heater supply operation, either rewire all heaters in parallel and use the original 12-volt tubes (three 12SK7's, one 12K8, one 12SR7, and substituting a 12J5 for the 12A6); or, use the original heater circuit and install 6-volt heater tubes which each draw 0.3 amperes (same 6-volt tubes as shown above).

AUDIO AMPLIFIER—

The original audio amplifier in the BC-453 may be sufficient for home-station operation under quiet conditions, but more volume is sorely needed to overcome the various noises encountered in mobile operation. A 5-watt amplifier and speaker in the 6 to 8-inch diameter range will provide plenty of sound.

A 3-stage amplifier circuit, shown in the schematic diagram, Fig. 1, was devised, and is easily driven by a 6J5 or 12J5, substituted for the original 12A6 pentode power audio amplifier in the BC-453. One section of a 12AX7 twin triode is a voltage amplifier; the other section functions as a phase inverter, driving the grids of a push-pull output stage with 12AQ5's (6AQ5's for a 6-volt heater supply).

The circuit constants shown provide good frequency response, but the higher audio frequencies will be accentuated if a 0.1-mfd capacitor is wired across the cathode resistor of the 12AX7 audio amplifier. A 0.006-mfd

capacitor across the output transformer attenuates higher audio frequencies.

The audio amplifier was constructed on a small metal plate about 4 inches square with flanges on all sides for mounting. Wiring should follow the usual practices for audio amplifiers. Note that the audio output signal from the BC-453 was taken from pin 2 of the plug on the rear of the chassis, as shown in the view on page 9.

FAST-ACTING AVC/S-METER CIRCUIT—

The operation of this fast-acting AVC circuit which can be added to the BC-453 receiver must be heard to be appreciated. The S-meter was designed to work on CW, sideband or amplitude modulated phone signals. The two-tube package, added in a small box to the left side of the receiver in the view on page 9, is well worth its weight in operating convenience.

Note in the schematic diagram, Fig. 2, that the 85-kilocycle signal from the BC-453 is picked up at the control grid of the first i.f. amplifier (V₅) so that the AVC amplifier stage, a 12AU6 pentode, will be completely free of stray BFO voltage. The selectivity of this amplifier must be broader than the signal channel in order to reduce the gain of the receiver when strong adjacent channel splatter is present. The "Q" of L₁ should not be too high, or the 85-kilocycle tuned circuit formed by it and the 190-760-mmf padder will be too sharp. A 5.5-millihenry iron core r.f. choke (Bud CH-922W, or equivalent) should be used for L₁.

The AVC voltage is rectified by the 1N34 diode and applied through a decoupling network back into the BC-453 receiver at the lower end of L₆, the secondary of the interstage i.f. transformer which drives the second i.f. amplifier stage (V₆). The AVC voltage also is applied to one control grid of a 12AT7 twin triode in a vacuum tube voltmeter type S-meter circuit. An SPDT switch provides for full AVC voltage for higher "DX" S-meter readings, or lower AVC for "Local" S-meter readings from strong signals.

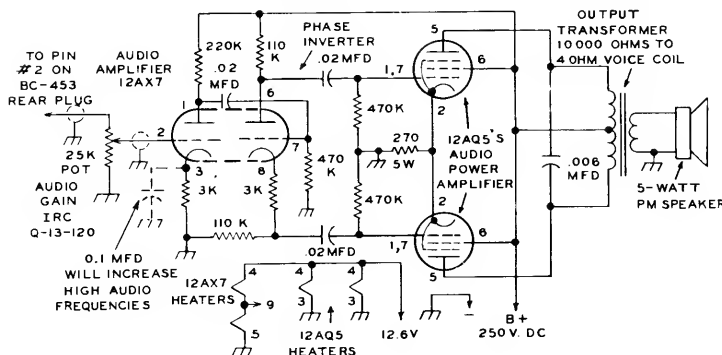
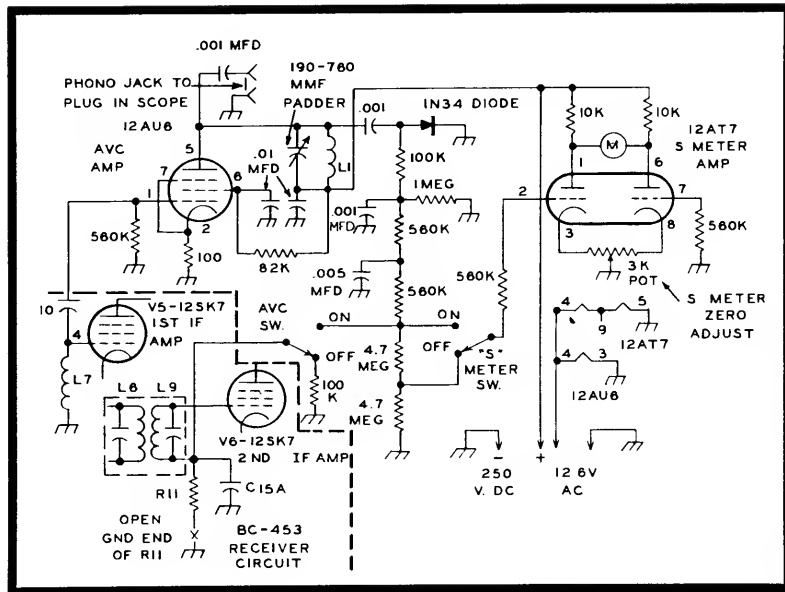

FIG. 1. SCHEMATIC DIAGRAM of a 5-watt audio amplifier for the BC-453 receiver. Audio output from the receiver is taken from the output transformer through pin 2 of the plug on the rear of the receiver chassis. Capacitances are in microfarads, and resistances are in ohms, 1/2-watt unless marked.

FIG. 2. FAST-ACTING AVC and S-meter circuit for the BC-453 receiver. Area inside dashed line at lower left corner of diagram shows points in the BC-453 circuit from which the i.f. signal is taken at pin 4 of the 12SK7 first i.f. amplifier; and connection to the lower end of L_9 into which AVC voltage from the AVC circuit is fed into the BC-453.



Note that a phono jack connection to the plate of the 12AU6 AVC amplifier provides a place to feed the i.f. signal to the vertical plates of an oscilloscope. By setting the horizontal sweep on the scope at 30 to 60 cycles, both incoming signals, and your own transmitter, may be checked for linearity.

The AVC/S-meter unit was constructed in a 4 x 2 1/4 x 2-inch Minibox (Bud CU-3015) and mounted on the left side of the BC-453. Extension shafts run from the controls to knobs, with the shafts supported on a small bracket. Exact arrangement of the AVC and S-meter circuit components will depend on the space available on each side of the BC-453 receiver in each mobile installation.

SIDEBAND SELECTOR SWITCH—

When properly aligned, the 85-kilocycle i.f. amplifier in the BC-453 has a bandwidth of about 2.5 kilocycles. This makes possible good SSB reception with considerable rejection of the unwanted sideband when the BFO signal is injected at either the upper or lower edge of the i.f. amplifier passband.

It is necessary only to install an SPST switch to add a 30-mmf capacitor across the BFO tuned circuit to change the frequency of the BFO so that it will provide the proper exalted carrier signal for reception of either upper or lower sideband signals. This addition, shown in the schematic diagram, Fig. 3, also includes increasing the plate voltage on the 12SR7 BFO tube by shunting R_{15} and R_{16} in the BC-453 with a 100,000-ohm, 1-watt resistor. This greatly increases the BFO injection for improved operation of the detector on SSB signals.

With the SPST switch open, adjust C_{28} in the BFO coil shield can so that upper sideband signals are properly received (BFO will

be at upper edge of i.f. amplifier passband). Then, close the sideband selector switch and tune in a signal transmitting lower sideband, which also should sound normal.

When a station transmitting, say, lower sideband is properly tuned in, and the station shifts to upper sideband, the SPST switch should then be opened, and the BC-453 receiver dial be tuned 3 kilocycles higher in frequency to properly receive the upper sideband. A bit of practice in changing sidebands will allow this shift to be made in a matter of seconds.

The combination of the amateur band converters and BC-453 receiver modified as described herein is capable of providing excellent amateur radio mobile reception.

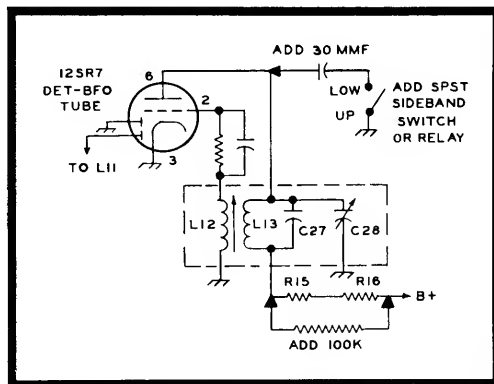

FIG. 3. SIDEBAND SELECTOR switch is added to BFO in BC-453 by adding a 30-mmf capacitor across BFO coil to shift BFO frequency. Locate switch and capacitor as close as possible to BFO tube to prevent radiation of signal from wiring.

12-TUBE ADAPTER FOR SINGLE SIDEBAND RECEPTION

AN ADAPTER TO CONVERT A SUPERHET INTO A TRUE SINGLE SIDEBAND RECEIVER
Materially Reduces QRM When Receiving AM, PM, CW or SSB Signals

From November-December, 1948



Fig. 1. Rear View of SSB Adapter

The single-sideband adapter, shown in Fig. 1 from a rear view, when attached to a superhet receiver will permit reception of single-sideband signals. Further, this combination will receive amplitude modulated phone signals, phase modulated signals, and c-w signals in a fashion which will enable the user to reduce the qrm on any frequency by at least fifty per cent.

In the case of reception of true single sideband signals with attenuated or suppressed carrier, the adapter furnishes a carrier against which the sidebands may be demodulated. By selecting the proper sideband with a switch, the modulation may be read. For reception of AM phone signals, this SSB receiver (adapter plus superhet) exalts the carrier component of the phone signal, making it effectively stronger than it would otherwise have been, and then allows reception of both sidebands, or either sideband singly. If qrm exists on one sideband, it can be avoided by receiving only the sideband on which the qrm does

not exist. Where qrm exists on both sidebands, one is selected which is qrm'ed the least.

Phase modulated or NBFM signals may be received in the same manner as AM signals. No special detection equipment need be added to the SSB receiver. For the reception of c-w signals, the SSB receiver furnishes the heterodyning signal so that the BFO in the superhet is not needed. True single-signal reception of c-w signals is achieved.

GENERAL PERFORMANCE

A single sideband receiver is not necessarily a "sharp" receiver, although the results obtained are usually superior to those obtainable with a receiver with steep-sloped IF curves. This means that if a signal has modulation with good audio fidelity, the SSB receiver will receive the full audio band, limited principally by the bandpass of the IF transformers in the superhet itself. Of course it is desirable to limit the audio range, both in transmission and reception,

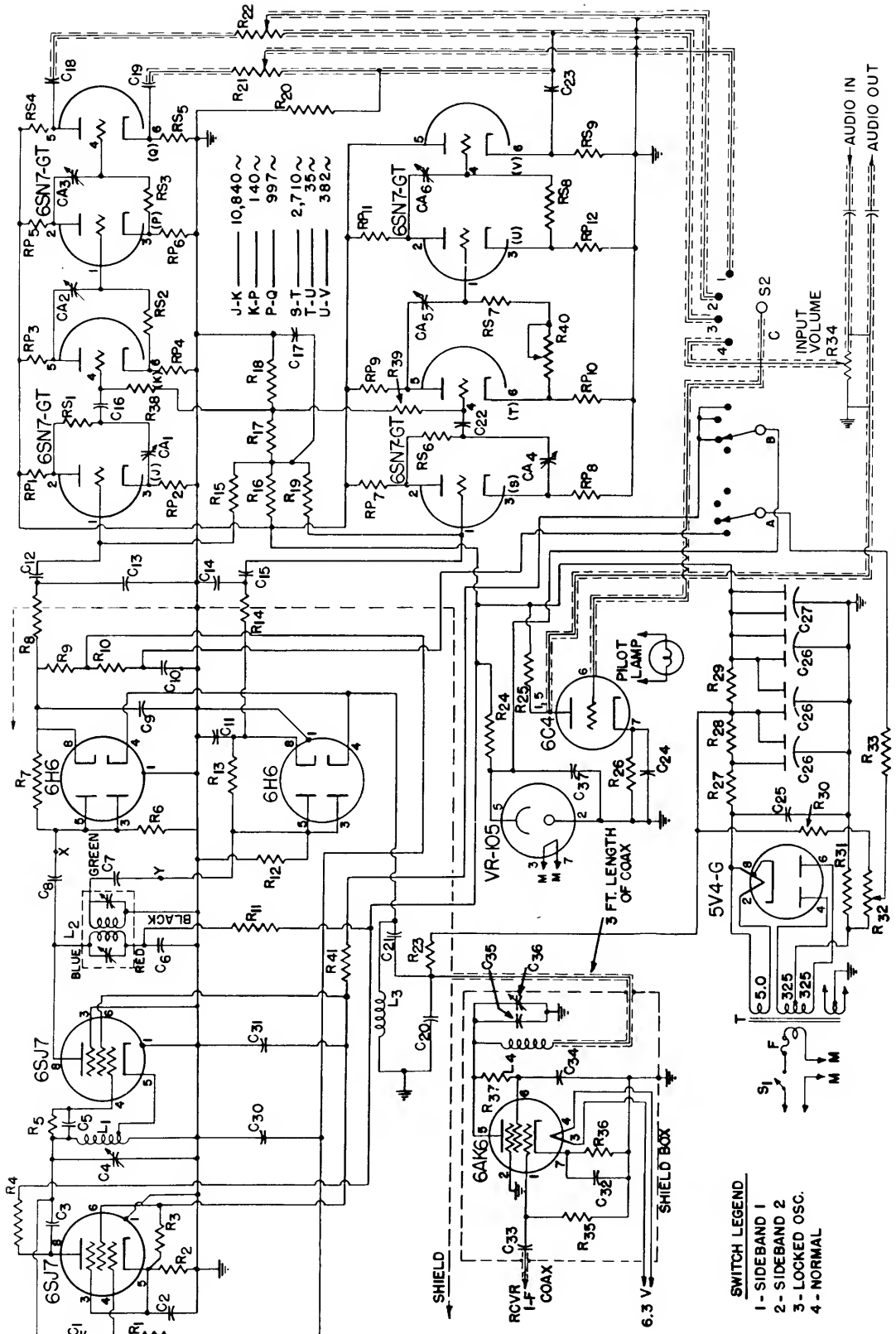

Fig. 2. Circuit Diagram of SSB Adapter

CIRCUIT CONSTANTS

$C_1 = 5$ mmf mica or ceramic
 $C_2, C_{30}, C_{31}, C_{32} = 0.1$ mf 200 V paper
 $C_3 = 0.001$ mf 600 V mica or paper
 $C_4 = 25$ mmf variable
 $C_5 = 100$ mmf mica
 $C_6, C_8, C_{29} = 0.01$ mf 600 V paper
 $C_7, C_9, C_{13}, C_{14}, C_{33} = 50$ mmf mica ($\pm 5\%$)
 $C_9, C_{11} = 500$ mmf mica ($\pm 5\%$)
 $C_{10}, C_{17} = 1.0$ mf 200 V
 $C_{12}, C_{16} = 0.05$ mf 200 V
 $C_{16}, C_{21}, C_{22}, C_{34} = 0.05$ mf 400 V
 $C_{18} = 0.5$ mf 400 V
 $C_{19}, C_{23}, C_{37} = 0.5$ mf 200 V
 $C_{20} = 0.006$ mf mica
 $C_{24} = 20$ mf 25 V (part of C_{27})
 $C_{25} = 20$ mf 450 V electrolytic
 $C_{26} = 40-40$ mf 450 V electrolytic
 $C_{27} = 40-40-20$ mf 450-450-25 V electrolytic
 $C_{35} = 750$ mmf mica
 $C_{36} = 150-500$ mmf mica trimmer

$CA_1 = 300$ mmf adjustable (see text)
 $CA_2 = 2200$ mmf adjustable (see text)
 $CA_3 = 1600$ mmf adjustable (see text)
 $CA_4 = 600$ mmf adjustable (see text)
 $CA_5 = 9000$ mmf adjustable (see text)
 $CA_6 = 800$ mmf adjustable (see text)

F = 3 amp. fuse

$L_1 = 2.5$ mH RF choke tapped at one pie
 $L_2 = 456$ KC IF Transformer (Millen No. 60456) (see text)
 $L_3 = 1$ pie of 2.5 mH RF choke
 $L_4 = 1$ pie of 2.5 mH RF choke with 100 turns removed (see text)

$R_1 = 470$ ohm $\frac{1}{2}$ watt
 $R_2 = 820$ ohm $\frac{1}{2}$ watt

$R_3 = 33,000$ ohm 1 watt
 $R_4, R_6, R_{23} = 0.1$ megohm $\frac{1}{2}$ watt
 $R_6, R_7, R_{12}, R_{13}, R_{15} = 0.22$ megohm $\frac{1}{2}$ watt ($\pm 5\%$)
 $R_8, R_{14} = 47,000$ ohm $\frac{1}{2}$ watt ($\pm 5\%$)
 $R_9 = 3.3$ megohm $\frac{1}{2}$ watt
 $R_{10}, R_{17} = 10,000$ ohm $\frac{1}{2}$ watt
 $R_{11} = 4700$ ohm $\frac{1}{2}$ watt
 $R_{15}, R_{19}, R_{20}, R_{28}, R_{29} = 2.2$ megohm $\frac{1}{2}$ watt
 $R_{16}, R_{30} = 0.33$ megohm 1 watt
 $R_{18}, R_{24}, R_{27} = 20,000$ ohm $\frac{1}{2}$ watt
 $R_{21}, R_{22} = 200,000$ ohm pot (linear taper)
 $R_{23} = 7500$ ohm 2 watt
 $R_{24} = 10,000$ ohm 10 watt
 $R_{25} = 1800$ ohm $\frac{1}{2}$ watt
 $R_{27}, R_{31} = 50$ ohm 2 watt
 $R_{28}, R_{29} = 300$ ohm 5 watt
 $R_{27} = 10,000$ ohm pot
 $R_{31} = 250,000$ ohm pot
 $R_{32} = 680$ ohm 1 watt
 $R_{10} = 100,000$ ohm pot
 $R_{11} = 500$ ohm 1 watt
 $RP_1, RP_2 = 4000$ ohm $\frac{1}{2}$ watt precision ($\pm 1\%$)
 $RP_2, RP_3 = 3000$ ohm $\frac{1}{2}$ watt precision ($\pm 1\%$)
 $RP_4 - RP_8 = 4000$ ohm $\frac{1}{2}$ watt precision ($\pm 1\%$)
 $RP_9, RP_{10} = 3000$ ohm $\frac{1}{2}$ watt precision ($\pm 1\%$)
 $RP_{11}, RP_{12} = 4000$ ohm $\frac{1}{2}$ watt precision ($\pm 1\%$)

$RS_1 = 50,000$ ohm $\frac{1}{2}$ watt ($\pm 5\%$) (not wire wound)
 $RS_2, RS_3, RS_4 = 0.5$ megohm $\frac{1}{2}$ watt ($\pm 5\%$) (not wire wound)
 $RS_5, RS_6 = 0.1$ megohm $\frac{1}{2}$ watt ($\pm 5\%$) (not wire wound)
 $RS_7, RS_8 = 5000$ ohm $\frac{1}{2}$ watt ($\pm 5\%$)
 $RS_9 = 5000$ ohm 1 watt ($\pm 5\%$)

$S_1 =$ SPST toggle
 $S_2 =$ six pole four position shorting type rotary switch (see text)
 $T =$ Power Transformer, 325-0-325 V. at 150 ma, 5 V. at 3A, 6.3 V. at 5A (Thordarson T-22R06)

to as narrow a range as possible, consistent with intelligibility. However, signals characterized by excessive frequency-modulated hum, carrier frequency drift, or overmodulated NFM will be immediately apparent. The amateur using a SSB receiver is thus able to spot difficulties of these sorts on any signal.

This SSB receiver does not cut out one sideband completely, but it attenuates it by approximately 40 db. This is the same as about 7 "S" points on the average receiver. Attenuation is such that signals which are no closer than 70 cycles and as far away as 5400 cycles from the carrier are attenuated at least 40 db. However, sufficient attenuation takes place between zero and 70 cycles so that unless an interfering signal is practically zero beat it can be eliminated in most cases sufficiently well to allow the desired signal to be copied.

The SSB receiver thus allows reception of all of the usual types of signals found on the ham bands, including single sideband signals. The principal advantage is that it allows the user to receive only one sideband at a time so that qrm is reduced by at least 50%.

ELECTRICAL DETAILS

The SSB adapter described here may be switched to any one of four types of reception by switch S_2 (see Fig. 2). Position 1 allows reception of one sideband of any type of signal described above. This will be either the upper or lower sideband, depending on which side of the received frequency the superhet oscillator operates. Position 2 permits reception of the other sideband. Position 3 is a locked-oscillator position. This means that the adapter is furnishing an artificial carrier (as it does also on positions 1 and 2) which augments (exalts) the carrier being received. This has the advantage of providing a strong non-fading carrier. The result is to reduce distortion on fading signals.

Position 4 of switch S_2 allows the receiver to function normally. The SSB adapter is not completely out of the circuit, since audio connections with the receiver require that audio be fed through the adapter. Experience has shown that position 4 is

seldom used once the operator is familiar with the operation of an SSB receiver.

The circuit diagram (Fig. 2) follows the principles set forth by D. E. Norgaard in his article "Practical Single-sideband Reception" in the July 1948 QST.

With reference to Fig. 2, the second 6SJ7 is the oscillator which generates the artificial carrier. Its frequency is the same as that of the receiver IF. Coil L_1 and condenser C_4 , along with the first 6SJ7 (reactance tube), are the frequency determining elements. Transformer L_2 is a 90 degree r-f phase shift circuit. The 6H6 tubes act as demodulators. The IF signal from the receiver is coupled through the 6AK6 tube (which functions as an impedance matching device) to both 6H6 tubes. The output of the 6SJ7 oscillator is also coupled to these 6H6 tubes. A portion of the output of the upper 6H6 is fed back through a low-pass RC filter ($R_9, R_{10}, C_{10}, C_{30}$) and acts on the 6SJ7 reactance tube so that automatic carrier synchronization is achieved.

The outputs from the two 6H6 demodulators are fed independently to two audio-frequency phase-shift networks. The upper two 6SN7-GT tubes with their associated components act as one network and the lower pair of 6SN7-GT tubes with their circuit components act as the other phase-shift network.

The audio outputs of these two networks are mixed by resistors R_{21} and R_{22} so that response from sideband 1, sideband 2 or both sidebands can be selected. The 6C4 is an audio amplifier tube.

The power supply circuit and the voltage regulator tube circuit are conventional. A large amount of capacitance is required because the two audio phase-shift networks must be supplied from a low impedance source of voltage.

CONSTRUCTIONAL DETAILS

Before starting the constructional work, it is wise to have all the necessary components on hand. Some of these need explanation at this point. Resistors RP_1 through RP_{12} are specified as $\frac{1}{2}$ watt precision resistors, with a resistance tolerance of $\pm 1\%$. These are an important part of the SSB adapter. Quantities

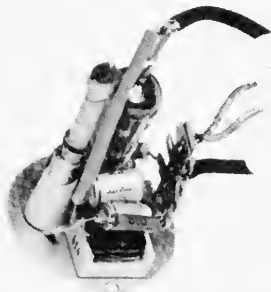

Fig. 3. Detail View of Probe with Cover Removed



Fig. 4. Detail View of Probe Shield Can

of this type are available at low prices. Naturally, one watt resistors may be used if $\frac{1}{2}$ watt ones are not available. It is possible to measure regular tolerance resistors until suitable values are found. This is not advisable unless the resistors chosen are certain to hold their measured values. A better alternative is to use stable resistors and pair them. For example, RP_1 and RP_2 need not be exactly 4000 ohms so long as they are the same value (within 40 or 50 ohms). Similarly, other pairs are RP_3, RP_4 ; RP_5, RP_6 ; RP_7, RP_8 ; RP_9, RP_{10} ; and RP_{11}, RP_{12} .

Resistors RS_1 through RS_9 are listed separately because it is desirable for them to be very stable although their exact value is not important as long as they hold that value. Precision resistors are usually stable types, and for this reason they are recommended although not required. Ordinary resistors are suitable, although the performance of the unit may suffer if these resistors change value with time.

Condensers CA_1 through CA_6 are shown as single condensers, but except for CA_1 , they are all multiple units. For example, CA_2 is listed as a 2200 mmf adjustable condenser. This made up by paralleling a 0.002 mf mica and a 150 to 500 mmf mica trimmer. Each of these specified condensers consist of a 150-500 mmf trimmer in parallel with mica condensers. CA_1 is simply a 100-500 mmf trimmer. The objective sought here is to permit adjustment of the RC products (RS_1 times CA_1 , RS_2 times CA_2 , etc.) to the proper value. This will be covered more thoroughly under "Tune-up Adjustments."

A Millen IF transformer is specified for L_2 . Other types will undoubtedly work, although difficulty may be experienced in obtaining the correct coupling between the primary and the secondary windings. Generally speaking, high stability air tuned IF transformers of the proper frequency are suitable. Switch S_2 is specified as a shorting type switch in order to provide smooth switching action.

Inductance L_4 should be approximately 0.15 millihenrys, for use with receivers having 450-470 kc IF amplifiers. This value of inductance was obtained from a 4 pie 2.5 mh choke, by removing 3 of the pies, then taking 100 turns off the remaining pie. The particular choke used was a Millen No. 34100.

The SSB adapter is built on a 17 by 10 by 3 inch chassis and uses a $8\frac{3}{4}$ inch relay rack panel. The 6AK6 probe (Figs. 3 and 4) is built into a $2\frac{1}{8}$ inch diameter by 4 inch long shield can (Millen No. 80006). It is desirable to follow the layout as shown. Fig. 1 indicates the general placement of parts, and Fig. 7 will serve as a drilling and layout guide. The rear of the chassis, referring to Fig. 1, is drilled for the two audio leads on the left, the coaxial connector on the right of center, and the fuse and a-c cord on the right. The front panel (Fig. 5) is drilled with four holes for the on-off switch, oscillator tuning control, control switch (S_2) and the pilot light. All holes are in a

center line $1\frac{1}{2}$ inches up from the bottom of the panel, and the side dimensions are three inches and five inches, respectively, in from either side of the panel.

The under-chassis view (Fig. 6) clearly shows the layout of parts. Note the shield which encloses the wiring for the two 6SJ7 and two 6H6 tubes. In order to better balance the layout in this shield compartment, the IF transformer could be moved toward the 6SJ7 oscillator tube.

It is necessary to make a small change in the IF transformer, assuming that the Millen No. 60456 is used. The blue lead should be unsoldered from the terminal point on the end of the coil form (which is a tap on the coil) and soldered instead to the stator of the primary tuning condenser. Also, the 24 mmf padding condenser across the primary coil should be removed.

The tune-up process will be simplified if a small piece of wire is soldered to the eight cathode connections of the four 6SN7-GT tubes. This wire should be about one inch long and arranged so that a clip lead may be attached to it.

The filaments of all the 6.3 volt tubes except the 6AK6 are wired to the 6.3 volt winding on the power transformer.

The 6AK6 tube is mounted in the probe chassis. The mounting piece is made of aluminum to fit the shield can. See Figs. 3 and 4. The coaxial lead which comes out the rear of this can connects to the receiver by means of a coaxial connector. The two filament leads and the coaxial line to the receiver are brought out the side of the can.

TUNE-UP ADJUSTMENTS

When the SSB adapter has been completed it is necessary to check the alignment carefully. In particular, the amount of attenuation obtainable on either sideband depends upon how well these adjustments are made.

Connect the adapter to the receiver in the following manner: The small can with the 6AK6 tube should be placed as close as possible to the last IF transformer in the receiver. The lead marked "receiver IF" should be soldered to the "hot" end of the secondary of the last IF transformer. Do not disconnect the lead from this point going to the second detector. The shielding braid on the coaxial cable should be stripped back only as far as necessary and then soldered to ground (receiver chassis). The 6.3 volt filament leads should be wired into a 6.3 volt a-c source in the receiver.

If the IF alignment of the receiver is questionable, it should be carefully realigned, following the manufacturer's directions. In any event, it is necessary to check the tuning of the secondary of the last IF transformer to compensate for the addition of the 6AK6 stage.

The other two connections are those marked "audio in" and "audio out." The audio connection to the input of the first audio amplifier must be opened. If the receiver has a phono input jack which accomplishes this, the two leads may be connected at this point. The "audio in" lead should be connected to the receiver connection which carries audio voltage from the second detector tube, and the "audio out" lead should be connected so that the audio signal on this lead is fed to the remainder of the audio system of the receiver. It is difficult to be specific about this because the adapter may be connected to a wide variety of receivers.

Turn on the receiver and the adapter. Allow both units to reach operating temperature. Turn off the avc on the receiver and set the adapter switch S_2 to position 4 (normal). Tune in a stable signal, such as a broadcast station. Adjust R_{34} and the receiver volume control until an adequate volume level is obtained. Change S_2 to position 3. Adjust condenser C_4 , which tunes the oscillator, until a beat note is heard. Adjust for zero beat. If no beat is heard, the oscillator is either not oscillating or is not able to reach the correct frequency. With the constants shown, the oscillator will operate in the 450 KC to 465 KC IF range. For higher or lower frequencies it may be necessary to change L_1 and C_4 .

Next, detune the receiver slightly so that a beat note is audible. Set the r-f gain on the receiver to ensure that no overloading is taking place. Adjust condenser C_{36} until this beat note is as loud as possible. If the receiver does not use a 450-465 KC IF, it may be necessary to change L_4 , C_{20} , C_{35} , and C_{36} in order to achieve resonance.

Tune the receiver to a low frequency beat note. Inability to hold a low-frequency beat note indicates that the r-f gain control should be reduced. Insert a 0-1 mil d-c meter between resistor R_6 and ground. The positive connection on the meter should connect to ground. A 0-5 mil d-c meter may also be used if a 0-1 mil meter is not available. The 0-1 milliammeter becomes, in effect, a 0-200 volt voltmeter (approximately). Adjust the tuning condenser in the primary of L_2 for a maximum reading of this meter. This adjustment probably will cause the oscillator to change frequency slightly and the beat note will change frequency. If so, adjust C_4 to get the original low-frequency beat note. Recheck for maximum meter reading and repeat if necessary. Remove the meter and connect R_6 to ground again. Place the meter between R_{12} and ground in the same way. Adjust the tuning of the secondary of L_2 for maximum meter reading. If the beat note changes, adjust C_4 as before.

The IF transformer L_2 is now tuned approximately to the receiver IF. It is next necessary to adjust the coupling of L_2 so that approximately equal voltages are fed to the two 6H6 tubes. This condition is satisfied when the voltages from "x" to ground and "y"

to ground are equal. (These voltages are those that were measured with the 0-1 millimeter.)

It may be desirable to connect a closed circuit jack between R_6 and ground and R_{12} and ground. Inserting a 0-1 mil d-c meter in the jack between R_6 and ground reads voltage "x" and between R_{12} and ground reads voltage "y".

Therefore, measure voltages "x" and "y." Normally "x" will be greater than "y," indicating that there is not sufficient coupling between the primary and the secondary of L_2 . Carefully heat the coil form of the Millen IF transformer with a soldering iron, through the large hole in the chassis, until the wax melts and the bottom coil can be pushed slightly toward the top coil. After this adjustment, retune C_4 to obtain the low-frequency beat note if this note changes frequency. Now measure voltages "x" and "y" by plugging the 0-1 mil meter into the two temporary jacks. Voltage "y" should increase as the coupling is increased. Several adjustments should be required as this process should be taken in easy steps to avoid too much coupling. Each time the coupling is adjusted the oscillator frequency should be adjusted to the low frequency beat with the signal in the receiver. Also the primary and secondary tuning condensers should be checked for proper tuning as indicated by a peak reading of the 0-1 mil d-c meter. (Peak the primary and read current in R_6 and peak the secondary by reading current in R_{12} .)

When voltages "x" and "y" are within ten per cent of one another the coupling adjustment may be considered complete. These voltages should normally be about 100 volts—half-scale on the 0-1 milliammeter.

The next step is to determine that transformer, L_2 is acting as a 90 degree phase-shift device. An oscilloscope is required for this and the following adjustments. The horizontal and vertical amplifiers in the scope may have differential phase shift, so first it is necessary to check for this condition.

Connect the "high" input leads of the horizontal and vertical amplifiers of the scope to pin 3 of the first 6SN7-GT tube (point J). The ground connections of the scope should be tied to the chassis of the SSB adapter. Detune the receiver so that a beat note of approximately 6000 cycles is obtained as heard in the speaker. Adjust the gain of the receiver (RF gain) until a relatively small signal is available. Adjust the horizontal and vertical amplifier gain controls on the scope until a straight line at a 45 degree angle is obtained. If the scope has no detrimental phase shift this line will be a thin straight line. If phase shift occurs, the line will be opened up, or split, so that it is in the form of a flat ellipse.

In order to correct this phase shift insert a 50,000 ohm potentiometer in the "high" lead of either the horizontal or vertical input at the scope. Adjust this potentiometer until the line becomes a solid line. If this is not possible, transfer the potentiometer to the other "high" lead. It should now be possible to adjust the resistance to give a straight line on the scope.

Next, remove one scope lead from point J and connect it to point S on the cathode of the first 6SN7-GT tube in the lower network. Do not remove the potentiometer and do not change the gain controls on the scope.

Change the receiver tuning to get a beat note of approximately 200 cycles. A circle should now appear on the scope tube. It may be lopsided, but it should resemble a circle. Adjust the condenser in the secondary of transformer L_2 until a perfect circle appears. If the best adjustment does not give a perfect circle then either the horizontal or vertical gain control should be adjusted to give equal horizontal and vertical deflections. This may upset the phase-shift compensation so check as before and readjust the 50,000 ohm potentiometer if necessary. Now repeat

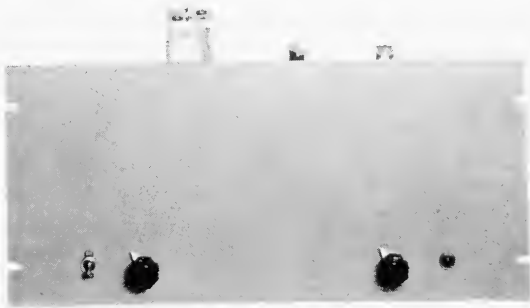

Fig. 5. Front View of SSB Adapter

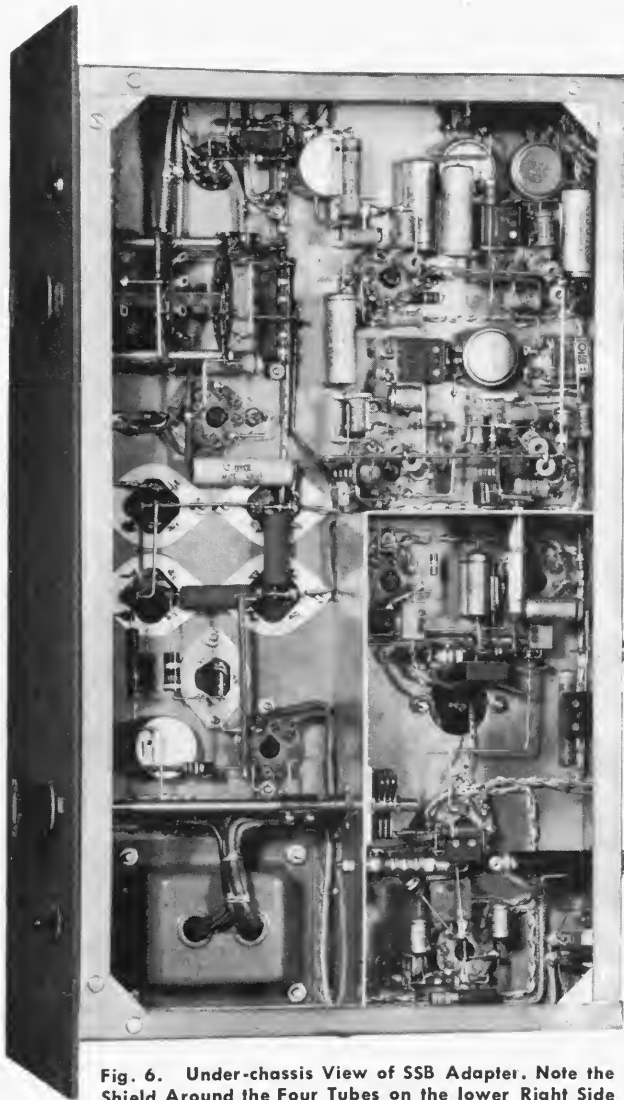

Fig. 6. Under-chassis View of SSB Adapter. Note the Shield Around the Four Tubes on the lower Right Side

the check for the circle by adjustment of the secondary tuning of L_2 . Detune the receiver to provide a 6000 cycle beat note. The circle may change size but it should hold its shape reasonably well. If not, the fault will probably lie in condensers C_7 , C_8 , C_9 , C_{11} , C_{13} , C_{14} or resistors R_6 , R_7 , R_8 , R_{12} , R_{13} , R_{14} . Ideally C_7 and C_8 should be the same value, that is, equal in capacitance. Also, C_9 and C_{11} should be equal, and C_{13} and C_{14} should be equal. Further, R_6 and R_{12} should be equal, R_7 and R_{13} equal, and R_8 and R_{14} should be equal. It may be necessary to measure them in order to pair them in the way which makes them as close to equal values as possible.

The final tune-up adjustment concerns the two audio frequency phase shift networks. In addition to the scope, an audio oscillator is required. This oscillator should be as good an instrument as can be obtained, since accurate calibration and good waveform is required in order to permit adjustment of the audio-frequency phase shift networks for optimum performance. This audio oscillator is required to generate the six audio frequencies shown in the circuit diagram (Fig. 2).

If the available oscillator is not accurately calibrated, it is not too difficult to calibrate it for the six frequencies involved. This can be done by means of a piano, if the piano is in tune. Using the proper key on the piano it is possible to produce a frequency which may be used as a calibration point, or in some cases as a sub-multiple of a required calibration. Of course, any other calibration means which is accurate may also be used.

When the oscillator is ready for use, turn on the adapter and remove both 6H6 tubes and set S_2 to position 4. The receiver need not be turned on. Connect the audio oscillator output to pin 8 of the upper 6H6 tube with the ground lead on the audio oscillator output going to the adapter chassis. Connect the ground connections of the horizontal and vertical amplifier inputs of the scope to adapter chassis. Connect the "high" connections of both amplifiers to point J. Set the audio oscillator at 10,840 cycles and adjust its output to approximately one volt.

The scope tube should now show a line at a 45 degree angle, or the gain controls should be adjusted

so that it does. If the line is thin and not split the phase compensation is correct. If not, adjust the 50,000 ohm potentiometer which should still be in series with one scope lead, as explained before. Next, move one lead from point J to point K. A figure which resembles a circle should now appear on the scope. Adjust the variable condenser CA_1 until a perfect circle is obtained. If this is not possible, then either the correct RC product (CA_1 times RS_1) is outside the range of adjustment or the gain controls on the scope are set in the wrong position. As before, adjust the gain controls so that equal horizontal and vertical deflection is obtained. Then check phase compensation again. This must always be done whenever the gain controls are changed. If the RC product is wrong change CA_1 , RS_1 or both in order to obtain the required values.

The next five steps are repetitions of the above as follows. Remove the scope lead from J and place it on K. Adjust the oscillator to 140 cycles. The phasing adjustment to get a single line, if it is required, may call for a condenser in series with one of the scope leads rather than the 50,000 ohm condenser. Try values between 0.001 and 0.1 mf. When phase compensation is correct, move one lead from K and place it on P. Adjust CA_2 until a perfect circle is obtained.

Next, move the lead that is on K to point P. Adjust oscillator frequency to 997 cycles. Check for phase compensation by getting a single line as before. Move one of the leads on P to point Q. Adjust CA_3 until a perfect circle is obtained. This completes the upper network adjustment.

Change the oscillator output so that it connects to pin 8 of the lower 6H6 in the circuit diagram. Connect both scope leads to point S and set the audio oscillator to 2710 cycles. Check for phase compensation as before, using either capacitance or resistance as required. Move one lead from S and place on point T. Adjust CA_4 until a perfect circle is obtained.

Change oscillator to 35 cycles and move the lead from S to T. Check for phase compensation. Move one lead from T to point U. Adjust R_{40} and CA_5 until a perfect circle is obtained. Usually adjustment of R_{40} alone is all that is required, but if a perfect circle

cannot be obtained, adjust CA_5 slightly and try again with R_{40} . Repeat until you get a perfect circle.

Change oscillator to 382 cycles and move the lead from T to point U. Check for phase compensation. Move a lead from U to point V. Adjust CA_5 until a perfect circle is obtained.

This completes the adjustment of the networks, and the balancing adjustments of R_{21} and R_{22} are next. Turn on the receiver, replace the 6H6 tubes in the adapter and allow the receiver to reach operating temperature. Set R_{21} and R_{22} to approximate mid-position. Connect the vertical input on the scope to the "audio out" lead. Set the horizontal plates to sweep frequency so that several sine waves will be visible on the scope screen after a 1000 cycle beat is obtained as described below. Tune in a steady signal, such as a broadcast station, while the adapter is in position 3. Set the r-f gain for a low signal level and make sure that the avc is turned off.

Tune the receiver slightly until the 1000 cycle beat note is obtained. Reduce the r-f gain until this heterodyne is just nicely audible with the audio gain opened most of the way. Now change S_2 to either position 1 or 2. On one of the positions the heterodyne will be weaker. This heterodyne will now be shown as a sine wave on the scope. Adjust the vertical gain until the sine wave covers about one-third of the screen. If the switch is in position 1, adjust R_{21} , or if in position 2, adjust R_{22} until the heterodyne sounds as weak as possible to the ear. At the same time the scope trace will decrease in amplitude. Next, retune the receiver through zero beat, to the opposite side of the signal until a 1000 cycle heterodyne note is obtained. Change switch S_2 to the other of the two sideband positions. Then adjust the other potentiometer (which was not touched before) for a minimum, checking both by the scope and by ear.

Finally, very carefully adjust the secondary tuning condenser of L_2 in conjunction with the potentiometer for a further reduction in volume of the heterodyne. Now retune the receiver for a 1000 cycle note on the other side of the signal and change S_2 to the other sideband. Readjust the potentiometer which controls this sideband for minimum heterodyne

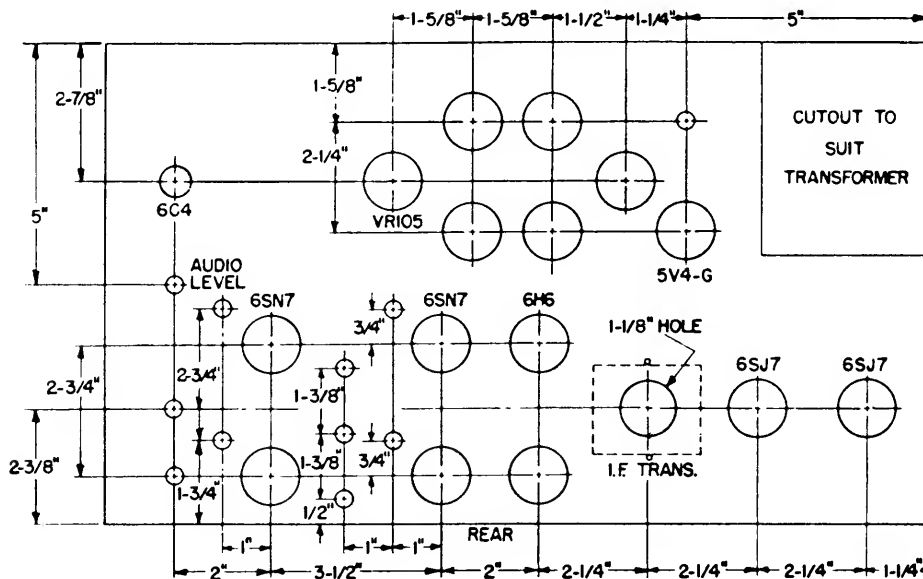

Fig. 7. Layout Guide for SSB Adapter

strength. If this is not as little as before, it will be necessary to go to the other sideband again and adjust L_2 secondary for equal rejection. It may be necessary to go back and forth several times to accomplish this. This rejection should be in the order of 40 db., which means a voltage ratio of about 100:1 as seen on the scope screen by switching S_2 back and forth between positions 1 and 2 while everything else is fixed.

Two more adjustments must now be made before the SSB receiver is really ready for use. Disconnect the scope. With S_2 in position 3, tune in a station. Be sure the input signal is small. Return to position 4. If the audio level changed, adjust R_{34} until no change in audio level is noted when going from position 3 to 4 or vice versa. (When in position 1 or 2 receiving AM signals the audio level will be lower by 6 db than the level observed in positions 3 and 4. This is normal.)

Lastly, tune in a signal zero beat in position 3 of S_2 . Make sure the unit is at operating temperature. Reduce r-f gain as far as practical. Switch to position 4, wait five seconds and switch to position 3. If a sliding frequency change is heard as the oscillator is pulling in, R_{32} needs adjustment. Make a slight adjustment, return to position 4, wait five seconds, then switch to 3. If the frequency change is less continue the adjustment process in that direction until no change of frequency is heard. If the frequency change was worse, adjust R_{32} the other direction and follow the above steps until no frequency change is heard.

The SSB adapter is now completely aligned and adjusted. If it is to be used on another receiver at some future date some of the previous steps in adjustment will need to be repeated. Condenser C_4 will have to be set for the new IF of the receiver and transformer L_2 may similarly need touching up. Also, R_{34} and R_{32} will probably need re-adjustment. It might be desirable further to check the settings of R_{21} and R_{22} in the manner previously described. The two audio phase shift networks should not require any re-adjustment at any time unless the components change value. This might be a good place to mention that the adjustments which have been described may seem very complicated, but they are much easier to perform than to describe in writing.

USE OF THE SSB RECEIVER

A person using a SSB receiver for the first time will be in a position very similar to that of a young child taking his first steps. That is to say, the child does not know how to walk until he has learned, and the user of a SSB receiver will not be able to use the SSB receiver to full advantage until he has had some experience with it. (And he is due for as big a thrill as the child gets—Editor's note.) However, there are

some basic rules to keep in mind. The *smaller* the r-f input, that is, the more the r-f gain can be turned down and still have a readable signal, the more certain one will be of obtaining maximum unwanted-sideband rejection. Always use the receiver with the avc off.

When the SSB receiver is used for the reception of c-w signals, it is not necessary to use the receiver BFO, as the necessary beat note is supplied by the oscillator in the adapter. Of course, when switch S_2 is in position 4 the BFO is used as usual with the receiver. Tuning is usually done in the locked oscillator position when the receiver is first in use, although with experience a c-w man will develop his own tuning patterns. For example, if the receiver is set to reject the high frequency sideband, and tuning is done from a low to a high frequency, then signals are not heard (unless they are very strong) until you have passed them frequency-wise.

For AM reception, the oscillator in the adapter will produce a heterodyne when tuning across phone signals, when in position 1, 2, or 3. This beat note disappears when the received signal is tuned to zero beat. It thus acts as a signal locator and is a real tuning aid.

For phase-modulated signals and narrow-band f-m signals reception is carried out in positions 1 or 2, assuming that the frequency swing is not excessive. It is not necessary to tune to one side of the signal to receive it. It might be well to emphasize that reception of PM and NBFM signals requires only the SSB adapter and a regular superhet—no special limiting device or FM adapter is necessary, or desirable, on the receiver. Merely tune in the signal to zero beat in position 3, and switch to either sideband (position 1 or 2) for reception.

Reception of single-sideband signals is obviously possible, whether the signal is transmitting a carrier or not. If a carrier is transmitted the SSB receiver will lock on it provided the carrier is of sufficient amplitude. If this is not true, it is only necessary to ensure that the receiver is kept properly tuned. After tuning in the signal, make certain that you listen on the sideband being transmitted.

The user of a SSB receiver will find that he switches back and forth between positions 1 and 2 rather often, during a QSO, in order to dodge QRM which comes up. (Unless he is listening to a single-sideband signal.) In addition, he will find that whatever interference is heard may also be further reduced by means of the crystal filter, assuming that the superhet has such a device.

For best results, the receiver to which this adapter is connected and the signals which are tuned, should have reasonably good frequency stability. The more perfect the receiver, the better the results will be.

THE G-E MODEL YRS-1 ADAPTER

FOR SINGLE SIDEBAND RECEPTION

The General Electric YRS-1 Single Sideband Adapter is a 14-tube unit which permits the single sideband reception of either modulated or unmodulated signals. It is designed to be used with any receiver having an intermediate frequency of approximately 455 kilocycles.

The YRS-1 functions essentially similar to the 12-tube single sideband adapter described in the November-December, 1948 issue of G-E HAM NEWS, which is repeated in this chapter on pages V-28 to V-35. The YRS-1 adapter has an additional 2-tube voltage regulating circuit to improve stability. Since instruction books for the YRS-1 are no longer available, the circuit and other essential details are repeated here.

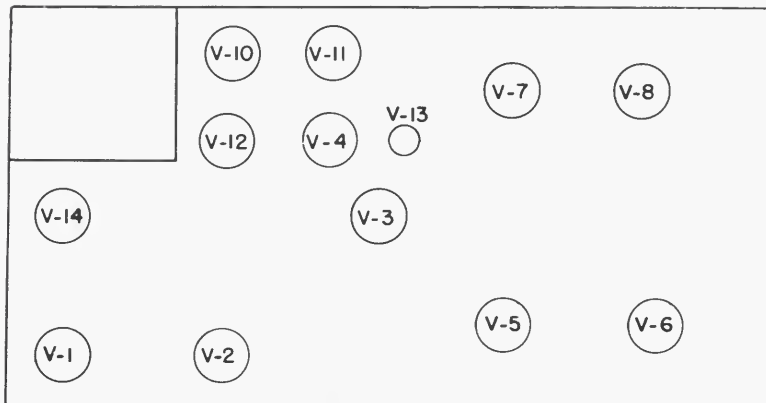
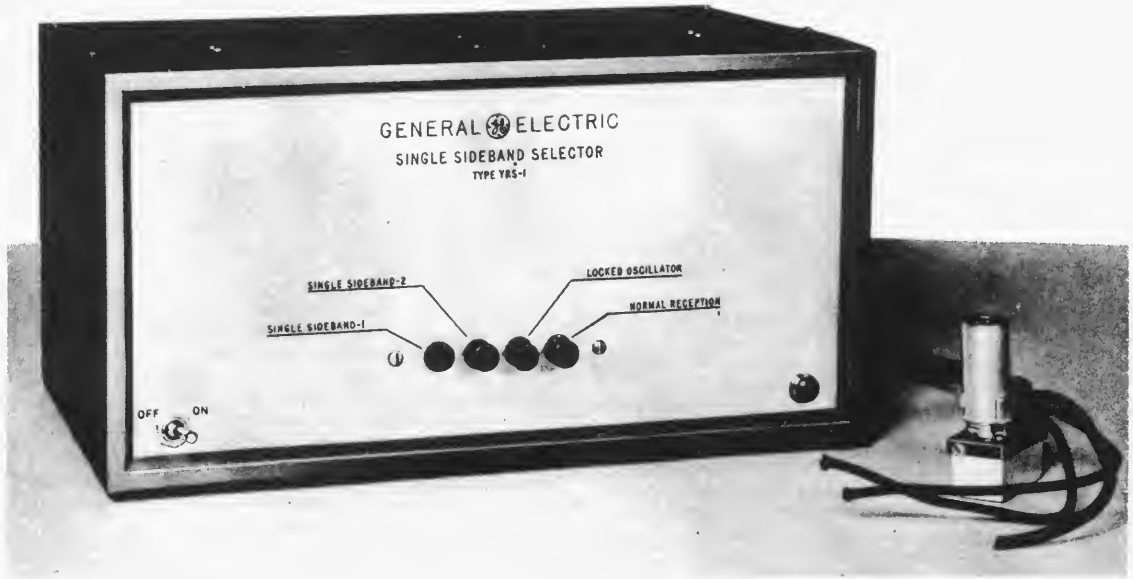

FRONT

Parts List for YRS-1 SSB Adapter



PART	DESCRIPTION	PART	DESCRIPTION
C ₁	Capacitor, ceramic, 5 mmf., 500v., 10%	C ₃₄	Capacitor, electrolytic, 10 mf., ±100%, -10%, 25 WVDC
C ₂	Capacitor, paper, .1 mf., 200v.	C ₃₅	Capacitor, electrolytic, 15 mf., ± 100%, -10%, 450WVDC
C ₃	Capacitor, paper, .001 mf., 600v.	C ₃₆	Capacitor, paper, .1 mf., 200v.
C ₄	Capacitor, ceramic, 15 mmf., 500v. 10%	C _{37, 38, 39}	Capacitor, paper, .01 mf., 600v.
C ₅	Capacitor, ceramic, 100 mmf., 500v., 20%	C ₄₀	Capacitor, paper, 1.0 mf., 200v.
C ₆	Capacitor, paper, .1 mf., 200v.	C ₄₁	Capacitor, paper, .01 mf., 600v.
C ₇	Capacitor, paper, .01 mf., 600v.	I ₁	Lamp, GE51 6-8v., .2 amp.
C _{10, C11}	Capacitor, ceramic, 50 mmf., 500v., 10%	L ₁	Coil, oscillator
C _{12, C13}	Capacitor, ceramic, 200 mmf., 500v., 10%	L ₂	Coil, choke
C ₁₄	Capacitor, mica, 2000 mmf., 500v., 5%	R ₁	Resistor, carbon, 470 ohms, 1/2w., 10%
C ₁₅	Capacitor, paper, .01 mf., 600v.	R ₂	Resistor, carbon, 100K., 1/2w., 20%
C _{16, C17}	Capacitor, ceramic, 200 mmf., 500v., 10%	R ₃	Resistor, carbon, 820 ohms, 1/2w., 10%
C _{18, C19}	Capacitor, paper, .05 mf., 200v.	R ₄	Resistor, carbon, 33K, 1/2w., 10%
C ₂₀	Capacitor, trimmer, 100-590 mmf.	R ₅	Resistor, carbon, 100K, 1/2w., 20%
C ₂₁	Capacitor, mica, 680 mmf., 500v., 10%	R _{7, 8, 9, 10}	Resistor, carbon, 220K, 1/2w., 20%
C ₂₂	Capacitor, trimmer, 100-590 mmf.	R ₁₁	Resistor, carbon, 10K, 1/2w., 20%
C ₂₃	Capacitor, trimmer, 600-1350 mmf.	R ₁₂	Resistor, carbon, 3.3 meg., 1/2w., 20%
C ₂₄	Capacitor, mica, 4300 mmf., 500v., 5%	R _{13, 14}	Resistor, carbon, 47K, 1/2w., 20%
C ₂₅	Capacitor, trimmer, 100-590 mmf.	R _{15, 16}	Resistor, carbon, 2.2 meg., 1/2w., 20%
C ₂₆	Capacitor, mica, 1100 mmf., 500v., 5%	R _{17, 18, 19, 20}	Resistor, precision, 1000 ohms, 1/2w., 1%
C ₂₇	Capacitor, mica, 10000 mmf., 300v., 5%	R _{21, 22}	Resistor, precision, 51K, 1/2w., 1%
C ₂₈	Capacitor, trimmer, 600-1350 mmf.	R _{23, 24, 25, 26}	Resistor, precision, 2000 ohms, 1/2w., 1%
C ₂₉	Capacitor, mica, 2000 mmf., 500v., 5%	R ₂₇	Resistor, precision, 82K, 1/2w., 5%
C ₃₀	Capacitor, paper, .05 mf., 600v.	R ₂₈	Resistor, precision, 100K, 1/2w., 5%
C ₃₁	Capacitor, paper, .05 mmf., 200v.	R _{29, 30, 31, 32}	Resistor, precision, 3000 ohms, 1/2w., 1%
		R ₃₃	Resistor, precision, 470K, 1/2w., 5%

PART	DESCRIPTION	PART	DESCRIPTION
R ₃₅ , 36, 37	Resistor, carbon, 3900 ohms, 1/2w., 5%	R ₅₆	Resistor, carbon, 330K, 1/2w., 10%
R ₃₈ , 39	Potentiometer, carbon, 500K 1/2w., 10%	R ₅₇	Resistor, carbon, 1 meg., 1/2w., 20%
R ₄₀	Resistor, carbon, 470 ohms, 1/2w., 10%	R ₅₈	Resistor, carbon, 2200 ohms, 2w., 10%
R ₄₃	Resistor, carbon, 100K, 1/2w., 20%	R ₅₉	Resistor, carbon, 10K, 1/2w., 20%
R ₄₄	Resistor, carbon, 39K, 1/2w., 10%	R ₆₀	Resistor, carbon, 470K, 1/2w., 10%
R ₄₅	Potentiometer, carbon, 150 ohms	R ₆₁	Resistor, carbon, 390K, 1/2w., 10%
R ₄₆	Resistor, carbon, 2200 ohms, 2w., 10%	R ₆₂ , 63	Resistor, carbon, 220K, 1/2w., 20%
R ₄₇	Resistor, carbon, 150K, 1/2w., 10%	R ₆₄	Potentiometer, carbon, 500K, 1/2w., 20%
R ₄₈	Resistor, carbon, 100K, 1/2w., 20%	R ₆₅	Resistor, carbon, 4700 ohms, 1/2w., 20%
R ₄₉	Resistor, carbon, 300 ohms, 2w., 20%	R ₆₆	Resistor, carbon, 100 ohms, 1/2w., 20%
R ₅₀	Resistor, carbon, 3900 ohms, 2w., 10%	S ₁	Switch, toggle, SPST
R ₅₂	Resistor, carbon, 22K, 1/2w., 10%	S ₂	Switch, pushbutton
R ₅₃	Resistor, carbon, 100 ohms, 1/2w., 20%	T ₁	Transformer, I. F., with trimmer capacitors, 455Kc.
R ₅₄	Resistor, carbon, 1800 ohms, 1/2w., 10%	T ₂	Transformer, power
R ₅₅	Resistor, carbon, 470K, 1/2w., 10%		

* Universal obtainable from any radio parts jobber.
All percentages shown are plus and minus.

Modifications to the YRS-1

I HAVE BEEN modifying my YRS-1 single-sideband adapter,¹ and some may be interested in certain changes I have made in this truly wonderful gimmick.

First, I replaced the toggle-type power switch on the panel with a gain-control-and-rotary-switch combination. The variable resistance is connected into the cathode circuit of the reactance modulator to control the frequency of the

¹ The YRS-1 is the commercial adaptation of the selectable-sideband adapter designed by W2KUJ. See Norgaard, "Practical S.S.B. Reception," *QST*, July, 1948.

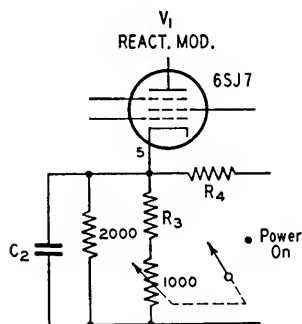

Fig. 1 — Wiring diagram of the modified YRS-1 reactance modulator to allow panel control. C₂, R₃ and R₄ refer to original components that are unchanged.

YRS-1 Modifications and Experiments

reinserted carrier (Fig. 1). This provides panel control for oscillator readjustment and for tuning s.s.b. stations, but, more important, it allows for compensation of warm-up drifts. After initial alignment, any drift in either the receiver or the adapter requires (otherwise) that the receiver be detuned. Oscillator frequency control further permits deliberate detuning of the receiver when desired, in order to favor the outer sideband frequencies or as an aid in avoiding interference.

Secondly, I provided a panel switch in the audio circuitry to permit normal operation of the receiver without turning on the 14 tubes in the YRS-1. This switch merely connects the audio from the receiver detector directly back into the receiver audio system.

Most interesting of all, I have wired the 6C4 audio output stage to take a 6J6, with the grids connected to the phasing networks, and the plates connected to two 'phone jacks (Fig. 2). This enables one to hear the sidebands separately on headphones, in addition to the operation through the receiver. With separate cords connected to each of the 'phones, the left ear hears the upper sideband, and the right ear hears the lower sideband.

This modification not only aids reception, but provides a certain "sense of direction." A heterodyne and the accompanying monkey-chatter associated with an interfering signal which appears on the right side of the panoramic adapter is heard in the right ear. Another interference on the left side may reach only the left ear. The brain tends to ignore the one-ear signals and favors the information from both ears. (Don Norgaard has mentioned this psychological effect.) With exalted-carrier reception, as you tune across a signal, the heterodynes seem to move right straight through your head. You know by "feel" which way to turn the tuning knob for oscillator lock-in.

With this binaural system, there seems to be a new realism. Voices (and music, too) seem to come to life. It is almost like walking into a broadcasting studio. Friends concur with me on

this. I cannot understand why the difference should be so great nor why the binaural way is more pleasant. Adjusting the level of the 'phones independently proves nothing. Tests made with both 'phones on show a marked difference in "realism" when one 'phone is switched from one sideband to the other, yet tests with only one 'phone show no difference when that 'phone is switched in the same manner.

Properly operated, the YRS-1 with exalted carrier greatly reduces the harmonic distortion normally heard on foreign 'phones, and makes listening to music from such stations much more pleasant. However, the selective fades on such stations, which affect the sidebands separately and produce dissimilarities between them, give a very interesting "three-dimensional effect" when heard this new way. It is very difficult to describe. Perhaps you have heard it. I don't mean to convey the impression that I am a dramatic type, but there is something mesmerizing about it. I have observed some interesting reactions and comments. Some people can't get enough of it; others seem to be a little frightened by the eerie sounds.

This new venture into "three-dimensional music" is startling, at first. The sound seems to flow around inside your head. There is a tendency at times to turn as though looking for the source of music. Choral music is weirdly beautiful and exciting. Pipe organ recitals reverberate mysteriously, and make you feel you are sitting high up in the belfry of a cathedral. To quote E.T. Canby,² switching from one to both sidebands gives "an impression of a tremendous bursting-outward into space." Sound suddenly "jumps away in all directions as though the performers had leaped into the air. Suddenly they are more than room distance away and fully sized, alive."

The usual question is, will it work with two loudspeakers? The answer is "yes and no." The effect is not nearly so interesting with speakers because both ears hear both speakers. However, I do often use the receiver speaker on the left side and a separate amplifier and speaker on the right side, and find it an improvement. I would like to get some more opinions and expressions from others who have tried dual single-sideband reception, or can be induced to make the simple changes (it took about half an hour) to add one more feature to the YRS-1.

² *Audio Engineering*, January, 1952.

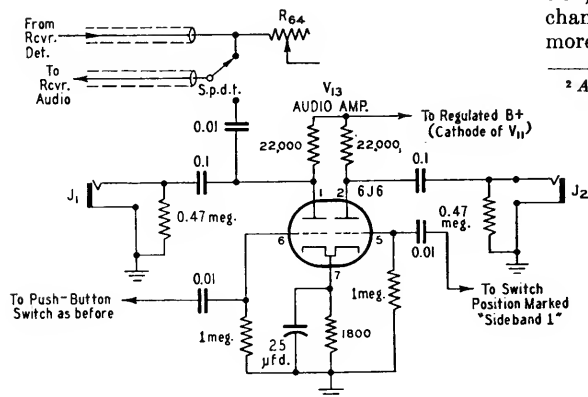

Fig. 2 — Wiring diagram of the modified audio amplifier to allow the use of split headphones. V_{13} is a 6C4 in the original unit — the connections to Pin 6 of the socket remain unchanged. With most receivers, J_2 will provide the upper sideband. The sideband from J_1 is selectable.

RF ACCESSORIES FOR SIDEBAND—

Easily Constructed Test Equipment—A Stable VFO, and a T-R Switch

SOLID HIGH-C VFO

For July-August, 1959

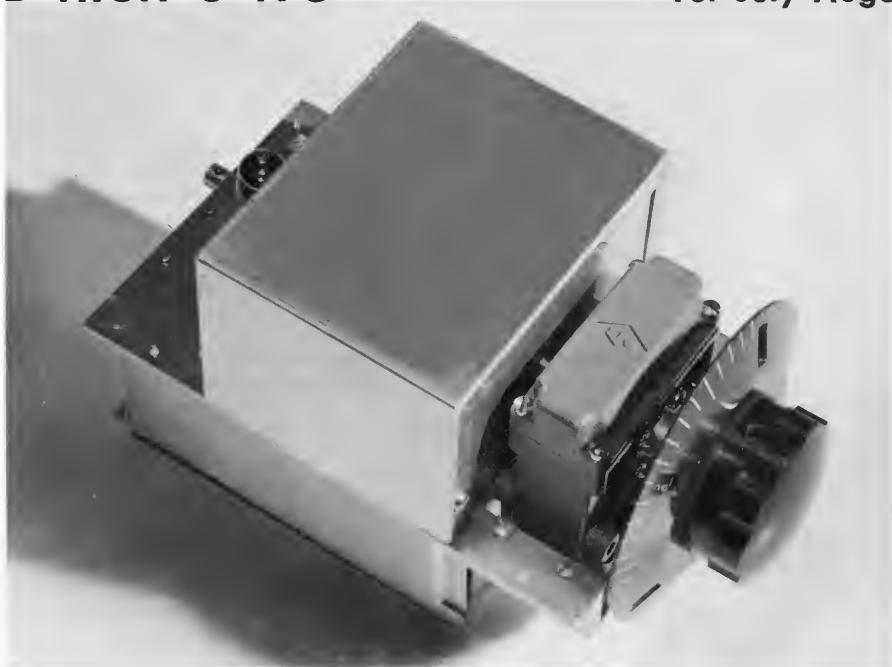

MEET THE DESIGNER . . .

W2FBS—Sam Johnson, needed a stable, tunable oscillator covering a single frequency range for the new heterodyne exciter he was building for his station. Having seen first hand the fine results obtained by ex-W2FZW (now K7BGI) with his high-C oscillator circuits for our 150-watt single band transmitters¹, Sam packaged his high-C circuit like the proverbial battleship. (See the cover photos and description starting on page 3.)

A long-time DX chaser with 230-odd countries confirmed, Sam can be heard almost daily on the CW DX bands, seeking new rare countries. W2FBS, incidentally, provided the technical guidance for our SPECIAL DX LOG ISSUE last year; also the 1959 supplement in this issue.

Vocationally, Sam is a mechanical engineer with General Electric's Gas Turbine Department at our king-sized manufacturing plant in Schenectady, N. Y.

¹See G-E HAM NEWS, November-December, 1957 (Vol. 12, No. 6) for details on this oscillator and transmitter.

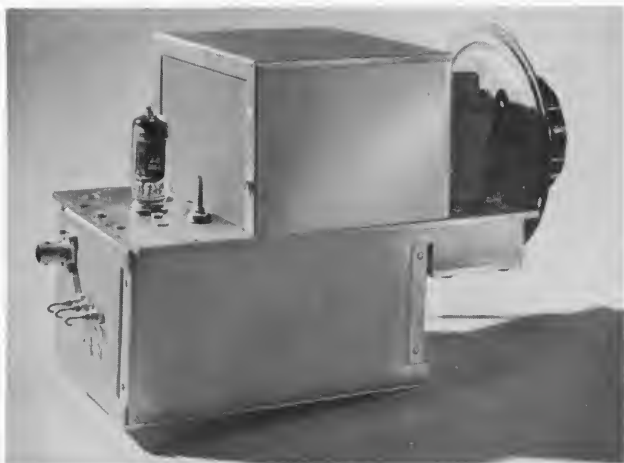

SOLID HIGH-C VFO

CHOOSE YOUR TUNING RANGE and build this completely shielded, stable oscillator for your new multiplying type, or heterodyne type, exciter.

There's a great many possible combinations of frequency-determining components for the high-C oscillator circuit. Several ranges for the popular amateur frequencies are covered here, along with constructional details for variable frequency oscillators with excellent mechanical rigidity. The oscillator shown was designed to be mounted in a hole cut in a larger chassis, with a rubber bushing under each corner.

The basic circuit, shown in the schematic diagram, FIG. 1, is essentially similar to our

(Continued on page 4)

TABLE I: PARTS LIST

- C₁... air variable with front and rear rotor bearings; see TABLE II for capacitance values (Bud or Hammarlund "MC" or Johnson "R" series).
- C₂, C₃... silvered mica or zero-temperature; see TABLE II, for capacitance values.
- C₄... silvered mica; 100 mmf above 5 megacycles in grid circuit; 200 mmf below 5 megacycles.
- C₅... 100-mmf silvered mica (use only for capacitive coupled output circuit).
- C₆... silvered mica; see TABLE II for values.
- J₁... chassis type coaxial cable connector.
- L₁... coils 1 inch long, wound on 1/2-inch diameter ceramic iron-slug tuned coil forms 2 1/2 inches long (CTC LS-7, or PLS7-2C4L); see TABLE II for inductance values and turns.
- L₂... CTC LS-3 ready-wound coils; or, wound on same forms as L₁; see TABLE II. Wind 2-turn coil over L₂ for link.
- RFC₁... pi-wound r.f. choke, 2.5 mh below 5 megacycles, 1 mh above 5 megacycles (National R-50, or equivalent).

TABLE II—TUNED CIRCUIT COMPONENT VALUES

FREQUENCY RANGE		CAPACITORS			COILS—WINDING LENGTH = 1 INCH			
"A" (MC)	"B" (MC)	C ₁ (mmf)	C ₂ , C ₃ (mfd)	C ₆ (mmf)	L ₁ (uh)	TURNS	L ₂ (uh)	TURNS
1.75—1.88	3.5—3.76	15—300	0.004	30	3.0	18	30—70	CTC LS-3 5-MC Coil
3.5—4.0	3.5—4.0	15—300	0.002	30	1.6	12	30—70	CTC LS-3 5-MC Coil
5.0—5.5	5.0—5.5	10—230	0.002	20	0.9	9	30—70	CTC LS-3 5-MC Coil
3.5—3.75	7.0—7.5	10—230	0.0025	50	1.3	11	6—13	CTC LS-3 10-MC Coil
3.5—3.72	7.0—7.44	15—300	0.004	50	0.9	9	6—13	CTC LS-3 10-MC Coil
6.0—6.5	6.0—6.5	10—200	0.002	20	0.6	7	14—20	44 on LS-7 Coil Form
6.0—6.25	12.0—12.5*	8—140	0.0025	20	0.5	6	5—9	22 on LS-7 Coil Form
7.0—7.2	14.0—14.4	8—140	0.002	20	0.5	6	4—8	19 on LS-7 Coil Form
8.0—8.22	24.0—24.66	6—100	0.002	60	0.35	5	0.5—1.0	CTC LS-3 30-MC Coil
8.33—8.66	25.0—26.0	6—100	0.002	60	0.35	5	0.5—1.0	CTC LS-3 30-MC Coil

FIG. 1. SCHEMATIC DIAGRAM of the high-C variable frequency oscillator. Components required to cover a given frequency range are listed in TABLE II. All capacitances are in mmf, unless otherwise specified. All resistances are in ohms, 1/2 watt (K=1000). Use either link coupling (L₂ and J₁) for the output; or capacitive coupling with C₅, depending on the driving requirements of succeeding stage.

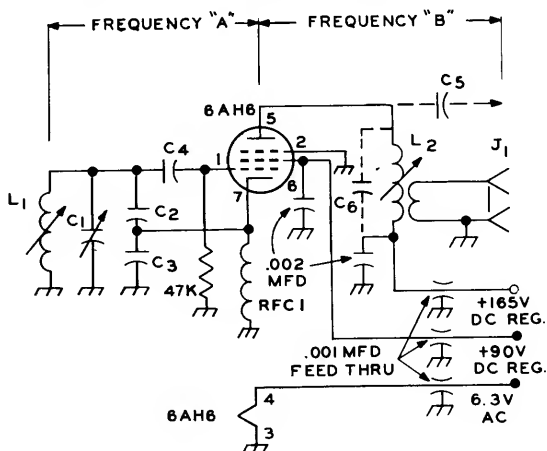

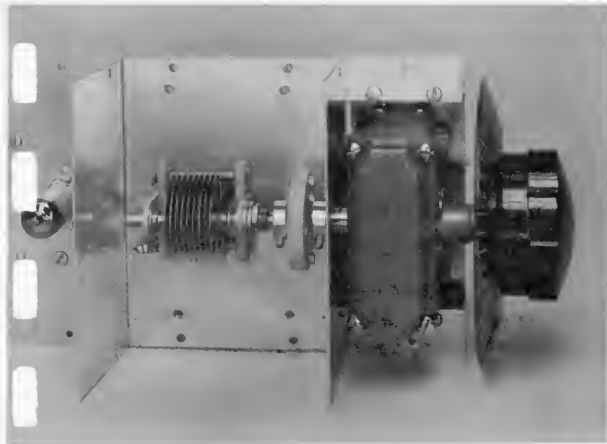

TOP VIEW of the oscillator with shield box over the tuning capacitor removed. Note how gear box on NPW dial fits into step-down shelf on chassis plate, permitting the dial shaft to line up with capacitor shaft. No spacers are used under feet on capacitor.

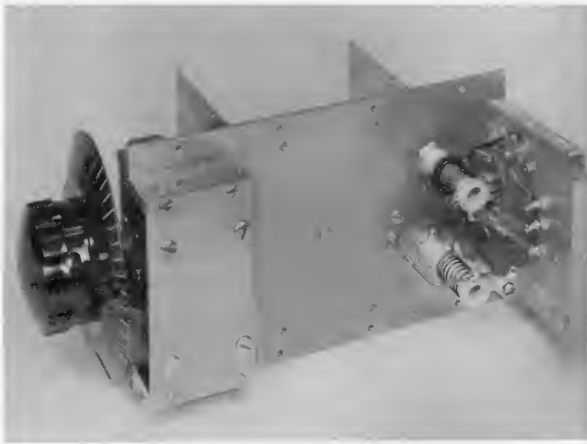

BOTTOM VIEW of the oscillator with bottom plate and side plates removed. The ceramic pillars for mounting C_2 and C_3 (see detail, FIG. 3) are just behind L_1 . The 0.001-mfd feedthrough capacitors for power connections are on the rear wall plate.

SOLID HIGH-C VFO

original high-C circuit (See "Technical Tidbits, High-C Oscillators," *G-E HAM NEWS*, November-December, 1957 Vol. 12, No. 6). Capacitors C_2 and C_3 form an r.f. voltage divider for feedback and also are in series across L_1 for determining the frequency of oscillation. The capacitance range of C_1 determines the frequency coverage.

A 6AH6 miniature pentode was chosen as the oscillator tube because of its high transconductance. The plate circuit (C_6-L_2) is usually tuned to the second harmonic of the grid circuit to lessen interaction caused by changes in load

on the oscillator output. Details on the critical components are given in TABLE I. A choice of component values for suggested tuning ranges is listed in TABLE II.

This particular oscillator was designed to cover an output tuning range of from 12.0 to 12.5 megacycles, a range of 500 kilocycles. With the National type NPW dial calibrated from 0 to 500, a tuning rate of about 1 kilocycle per dial division was achieved. However, the tuning rate was not precisely linear. A well-calibrated, smooth running tuning dial should be used on this—or any—VFO.

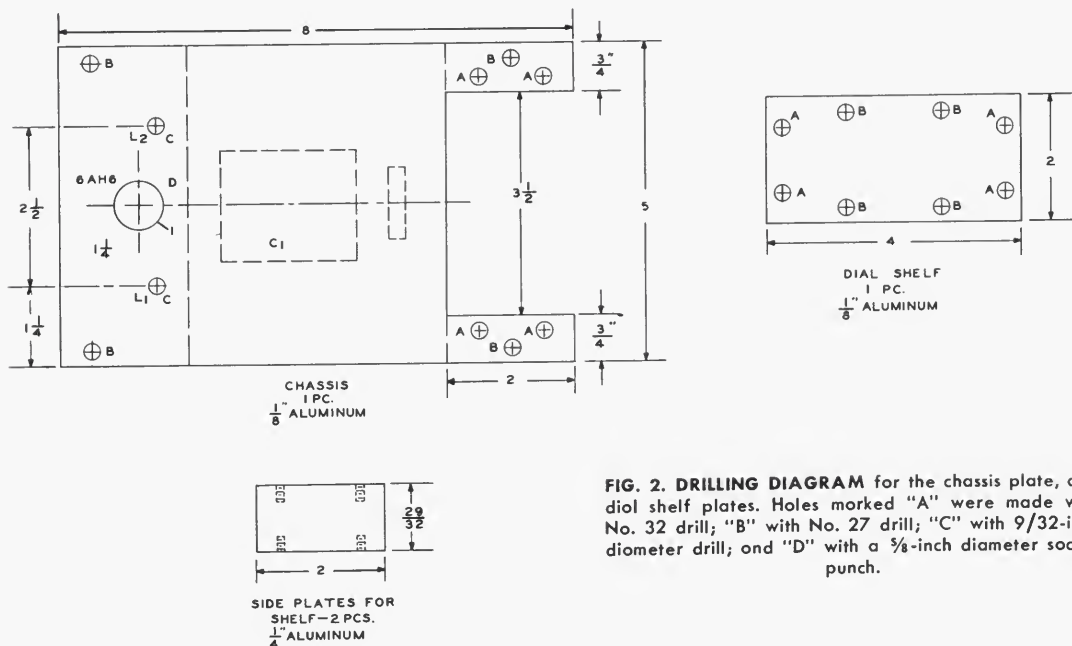

FIG. 2. DRILLING DIAGRAM for the chassis plate, and dial shelf plates. Holes marked "A" were made with No. 32 drill; "B" with No. 27 drill; "C" with 9/32-inch diameter drill; and "D" with a 3/8-inch diameter socket punch.

HIGH QUALITY insulation—steatite or ceramic—should be on the components selected for the oscillator wherever possible. This helps reduce frequency drift. The oscillator grid coil (L_1) had a measured "Q" of over 200 on the coil form specified, in spite of the small diameter.

CONSTRUCTIONAL DETAILS are covered in the photos and the drilling diagram for the chassis plate and shelf, FIG. 2. The shield box for C_1 is a 3 x 4 x 5-inch Minibox (*Bud* CU-30). The shield under the chassis plate was made from *See-Zak* aluminum expandable chassis parts. The front and rear side rails are *See-Zak* R-34 (3 inches high, 4 inches long). A *See-Zak* P-44 chassis plate forms the bottom cover. Hole locations in the chassis plate for this shield should be marked from the shield parts.

A special mounting, as shown in the detail drawing, FIG. 3, was made for C_2 and C_3 . This assembly is located next to L_1 , as shown in the bottom view. The three 0.001-mfd feedthrough capacitors for the power leads, and the r.f. output connector, (J_2), mount on the rear side rail. The power leads and link on L_2 were made with insulated hookup wire; tinned No. 12 bus wire was used for r.f. leads.

TUNEUP consists simply of adjusting the tuning slug in L_1 so that the desired tuning range is covered. A specific frequency at either the lower or upper end of the tuning range may be reached by setting C_1 at maximum, or minimum, capacity respectively, and adjusting L_1 .

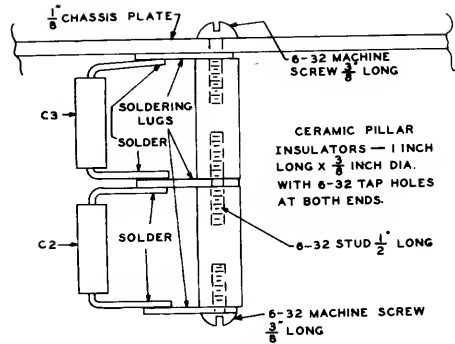

FIG. 3. ASSEMBLY DETAIL of the mounting for C_2 and C_3 . Leads were clipped short and bent at right angles, close to capacitor body for rigidity. Threaded stud between pillars was made from 6-32 x $\frac{3}{4}$ -inch machine screw with head removed.

Warmup frequency drift of the 12-megacycle model oscillator was about 1 kilocycle in ten minutes, after which the oscillator remained within 100 cycles of the nominal frequency. This was without temperature compensating capacitors and thus could have been reduced appreciably.

A bulletin is available with a full size chassis layout drawing, also a schematic diagram of a mixer, crystal oscillator and amplifier unit which, when used with this oscillator, forms a heterodyne type exciter.

Construction Notes for the Solid VFO

1. Size of the wire used to wind L_1 and L_2 was not given in the Parts List on page 3 of the July-August, 1959 issue of G-E HAM NEWS. The wire for L_1 is No. 18 enameled (try to use wire with Formex, Alkanex, or Formvar insulation; these insulations have higher r.f. resistance, as well as being more resistant to chipping and cracking). Use No. 24 enameled wire on all L_2 coils which must be home wound.
2. The CTC coil forms listed are products of the Cambridge Thermionic Corp., of Boston, Mass. They are available from several mail order radio parts distributors, including the Radio Shack Corp., 730 Commonwealth Ave., Boston (page 139 in 1959 catalog); Fort Orange Radio Dist. Corp. Co., 904 Broadway, Albany, N.Y. (page 79 in 1959 catalog); Allied Radio Corp., 100 N. Western Ave., Chicago 80, Ill. (page 114 in 1960 catalog); Walter Ashe Radio Co., 1125 Pine St., St. Louis 1, Mo. (page 69 in 1959 catalog); and World Radio Labs, 3415 W. Broadway, Council Bluffs, Iowa (page 46 in 1959 catalog).

Monitors Your AM or SSB Transmitter

From September-October, 1956



The problem of visually monitoring your audio is solved by building a HAMSCOPE, as shown, between your amplifier grid and plate meters—or, if you prefer, in a separate unit constructed to suit your needs.

—Lighthouse Larry

THE HAMSCOPE

DESIGN CONSIDERATIONS

The "HAMSCOPE" is a simplified cathode-ray oscilloscope—designed specifically for checking the operation of amplitude-modulated and single-sideband transmitters operating in the 1.8–30-megacycle frequency range. The screen patterns will tell a more complete story about linearity, distortion, percentage of modulation, than meters or similar indicators. Since a linear sweep, vertical and horizontal deflection amplifiers and other complications are not needed for examining transmitter output, this 'scope is reduced to essentials—the cathode-ray tube; a tuned circuit for applying RF voltage to the vertical deflection plates; a 60-cycle or audio frequency sweep on the horizontal plates; and a high-voltage power supply.

Choice of the cathode-ray tube determines other factors, such as over-all size and voltages, and will be considered first. Even though a late type, the 3KP1, was used in this circuit, older cathode-ray tubes—the 3AP1, 3BP1, 3CP1, 3GP1, 3MP1, or the 2AP1, 2BP1, etc.—should be suitable. Many amateurs already have these tubes stored away, with the intention of putting them to work in a unit of this type.

A cathode-ray tube is similar to other thermionic vacuum tubes in that electrons emitted from the hot cathode are attracted toward a more positively charged anode. The main difference in C-R tubes is that the cathode and several disk or cylindrical-shaped elements, called the electron gun, concentrate the electron stream into a thread-like beam. These elements each have a small axially aligned hole through which the beam passes. The control grid, adjacent to and negatively charged with respect to the cathode, controls the intensity of this beam. The next element is the focusing anode, operating at 30 to 50 percent of the total supply voltage. The accelerating anode, next in line and having a high positive charge, pulls the electron beam through the gun and hurls it toward a phosphor-coated screen on the faceplate. A small spot appears on this screen when voltages applied to the elements have the proper relationship. Last element in the gun, four deflection plates arranged in pairs about the electron beam axis, bend this beam in accordance with a difference in potential between the pairs. Because each point on the fluorescent screen continues to glow briefly after being energized by the beam, the spot traces a composite pattern of any varying deflection voltages applied to the plates.

The electron beam also will be deflected by stray magnetic fields. Presence of a permanent magnet or inductance energized by direct current near the tube neck will cause the spot to move from its normal position. An alternating-current field, such as that which surrounds power transformers, will cause the spot to sweep back and forth at right angles to the plane of the field. For this reason, selecting a location for the power transformer which causes no stray beam deflection is usually the most critical mechanical problem encountered in constructing cathode-ray oscilloscopes. Since the transformer may induce a field into a steel chassis if it is fastened directly to that chassis, an adjustable transformer mounting bracket helps overcome this difficulty.

CIRCUIT DETAILS

Since current flow through a cathode-ray tube is quite small, voltages for the elements may be tapped from a high resistance voltage divider connected across a power supply which need deliver only a few milliamperes of current. Resistance values in this voltage divider, shown in the schematic diagram, Fig. 1, have been selected to offer a wide adjustment range on the "INTENSITY" and "FOCUS" controls, and to place some load on the power supply. Different values should

not be necessary even with other cathode-ray tube types and higher supply voltages. Centering controls for positioning the pattern were considered an unnecessary refinement, since most cathode-ray tubes are constructed to place the undeflected spot within $\frac{1}{4}$ inch of the center of the screen.

If the cathode or control grid is operated near chassis potential (the "normal" method of connecting B-minus), the accelerating anode and deflection plates must have a high positive potential applied to them. This creates a dangerous shock hazard in circuits where the deflecting signal to be observed is connected directly to these plates. The danger is easily reduced by operating the latter elements near chassis potential and applying a negative high voltage to the control grid-cathode end of the voltage divider network. This system also avoids the necessity of using high-voltage coupling capacitors to isolate the deflection plates, the alternate method of reducing the shock hazard. Most 2- and 3-inch cathode-ray tubes will have sufficient pattern brightness for this application if at least 800 volts appear across the voltage divider, although operation at 1000 to 2000 volts insures some reserve brightness. One side of the cathode-ray tube heater is connected to the negative high voltage to insure that the heater-cathode potential difference will not rise above the rated value.

A built-in negative high-voltage supply is pictured in the schematic diagram, rather than depending upon the transmitter being monitored to furnish positive high voltage. Thus, the 'scope will check even *flea-powered* transmitters. Even though special oscilloscope power transformers are available (Merit P-3170 and Triad A-43-C), a conventional replacement-type power transformer delivering at least 600 volts across the *entire* secondary winding was used for T₁. Because of the low current drain, a simple half-wave rectifier and capacitor input filter, which charges up to the peak AC transformer voltage, is suitable. Capacitors C₁ and C₂ should have a working voltage rating at least $1\frac{1}{2}$ times the transformer secondary voltage.

As only a 5-volt rectifier heater winding with no center tap was available on this transformer, the 2.5 volts required by a 2X2A rectifier tube is supplied by inserting dropping resistor R₁ in series with the heater. One section of a 5R4-GY full-wave rectifier tube may be used in place of the 2X2A, R₁ not being required for this tube. The maximum AC voltage-per-plate ratings of most other full-wave rectifier tubes will be exceeded in this circuit, and should not be used.

Both power and horizontal sweep selection are controlled by S₁, wired so that the 'scope is "OFF" in one position. The second position applies line voltage to the power transformer and 25,000-ohm sweep control potentiometer, and the third position also connects the power and applies an external audio voltage, fed through J₁ into this control. The primary of a single plate to push-pull grid interstage audio transformer is connected between the arm and one side of the potentiometer and both ends of the secondary winding connect to the horizontal deflection plates. A transformer with a large step-up ratio, 1:4 or higher, will sweep the full width of most cathode-ray tubes with 20–30 volts RMS applied to the primary. A linear horizontal sweep generator would needlessly complicate the circuit, since the center portion of a sine wave sweep is sufficiently linear.

The vertical deflection plates are connected across tuned circuit C₃—L₁, resonant at the frequency of the RF signal being checked. A small RF voltage fed through a coaxial cable plugged into J₃ is link-coupled to the tuned circuit through L₂. Any combination of variable capacity and inductance which will tune to the desired frequency may be used in place of the parts specified for C₃, L₁ and L₂. The large maximum capacity specified for C₃ enables the tuned circuit to cover all popular bands with only 2 coils, but a bandswitching coil system may be incorporated for added convenience.

MECHANICAL DETAILS

Most relay rack panels with holes cut for three 3-inch meters have about $6\frac{1}{2}$ inches of space between the two outer meter holes, limiting one "HAMSCOPE" dimension to less than this figure. Over-all depth of the unit is regulated by the depth of the relay rack cabinet into which the 'scope will be mounted. Most cabinets are more than 14 inches deep, but the 6- by 14- by 3-inch chassis used on this model is the largest that may be safely accommodated. A chassis drilling diagram is not shown, since available transformers, capacitors, tubes, etc., may vary in size somewhat from the components pictured in Fig. 2. Instead, approximate dimensions for locating major parts have been marked on the side view illustration, Fig. 3. Actual parts to be

used should be placed in and about the chassis to find locations which will not conflict with the cathode-ray tube, control shafts, brackets, etc.

Holes for the "SWEEP" potentiometer and S_1 are drilled as close as possible to the upper chassis corners, and corresponding holes for panel-bearing assemblies are drilled at the lower corners. On this model, the hole centers were three quarters of an inch each way from the outside chassis wall. The four control knobs will then form a rectangle about the tube face.

The faceplate end of the tube is not held in a clamp, but rests between two strips of rubber cemented to the underside of the chassis deck and bottom lip. A square hole in the panel end of the chassis for the tube is preferable to a round hole, since the bottom lip must

COIL TABLE

1.8—7.5 MEGACYCLES

L_1 —32-uh, 34 turns No. 24 enameled wire, center tapped, wound in two 17-turn coils spaced $\frac{1}{4}$ inch, $1\frac{1}{2}$ inches long on a $1\frac{1}{2}$ -inch-diameter 5-prong molded phenolic plug-in coil form.

L_2 —3 turns No. 20 insulated hook-up wire at center of L_1 .

9—30 MEGACYCLES

L_1 —1.3-uh, 6 turns No. 24 enameled wire, center tapped, wound in two 3-turn coils spaced $\frac{1}{4}$ inch, $\frac{3}{4}$ inches long on same type form.

L_2 —2 turns No. 20 insulated hook-up wire at center of L_1 .

Commercially available coils which may be substituted for the above coils include the Bud CCL or OLS; or the B & W MCL, JCL and JVL series.

PARTS LIST

C_1, C_2 —0.1 to 0.5-mfd paper, working voltage 1.5 times secondary voltage of T_1 .

C_3 —Two-section variable, 10—400-mmf per section.

F_1 —Chassis-type fuse holder with 1-ampere fuse.

J_1 —Open circuit midget 'phone jack.

J_2 —Chassis-type male 2-prong power connector.

J_3 —5-prong ceramic tube socket.

J_4 —Chassis-type coaxial cable connector.

J_5 —5-prong ceramic tube socket.

R_1 —5-ohm, 10-watt adjustable resistor.

S_1 —4-pole, 3-position, single section non-shorting tap switch (Mallory 3243J).

T_1 —Replacement type power transformer with a 600—750-volt, 40-ma high voltage winding; 5-volt, 2-ampere and 6.3-volt, 0.6-ampere heater windings; 115-volt, 60-cycle primary.

T_2 —Single plate to push-pull grid interstage transformer having a step-up ratio of 1:3 or higher (Stancor A-53-C, A-64-C).

V_1 —2X2A or 5R4-GY rectifier tube (see "CIRCUIT DETAILS").

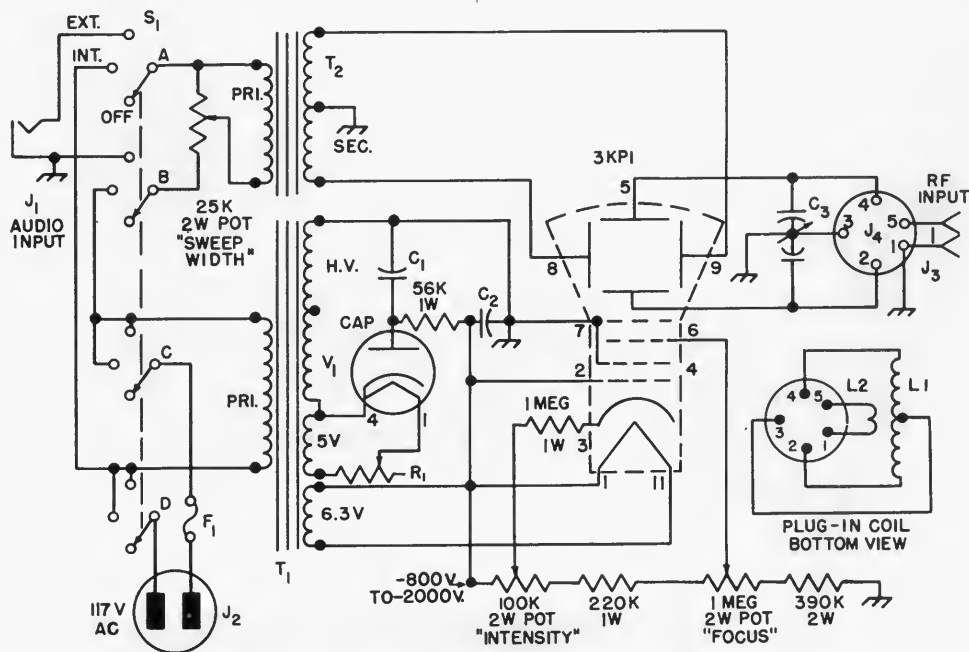

Fig. 1. Complete schematic diagram of the "HAMSCOPE."

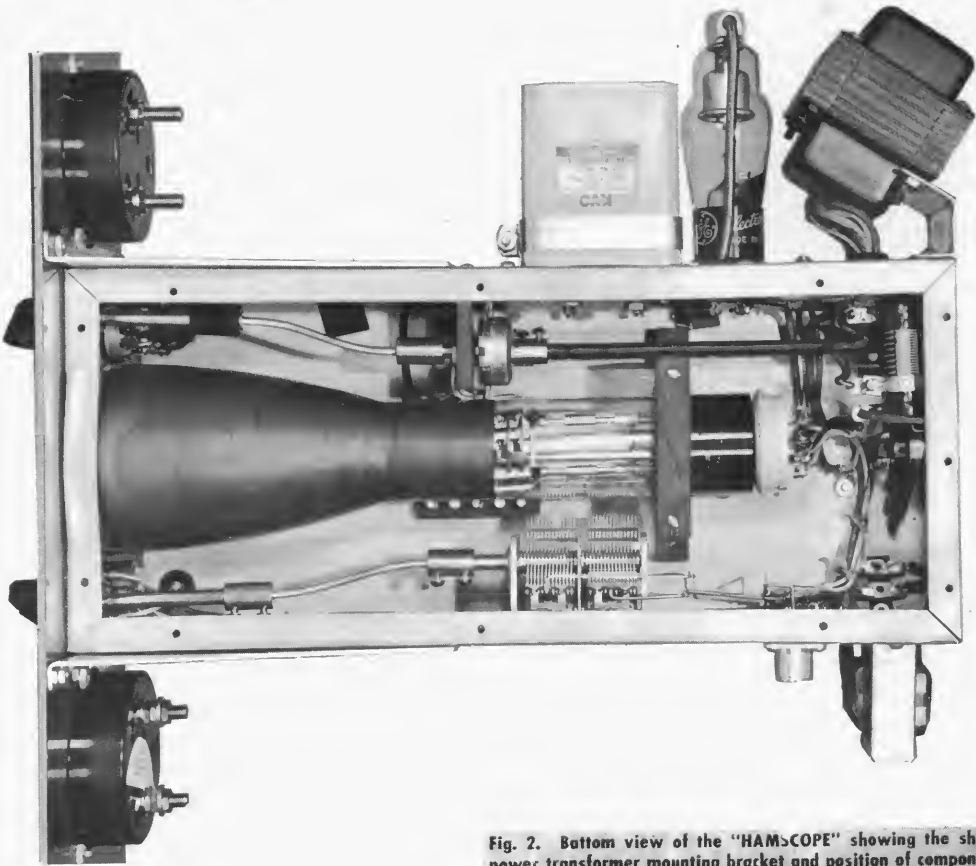

Fig. 2. Bottom view of the "HAMSCOPE" showing the shape of the power transformer mounting bracket and position of components inside the chassis. The plug-in coil has been removed.

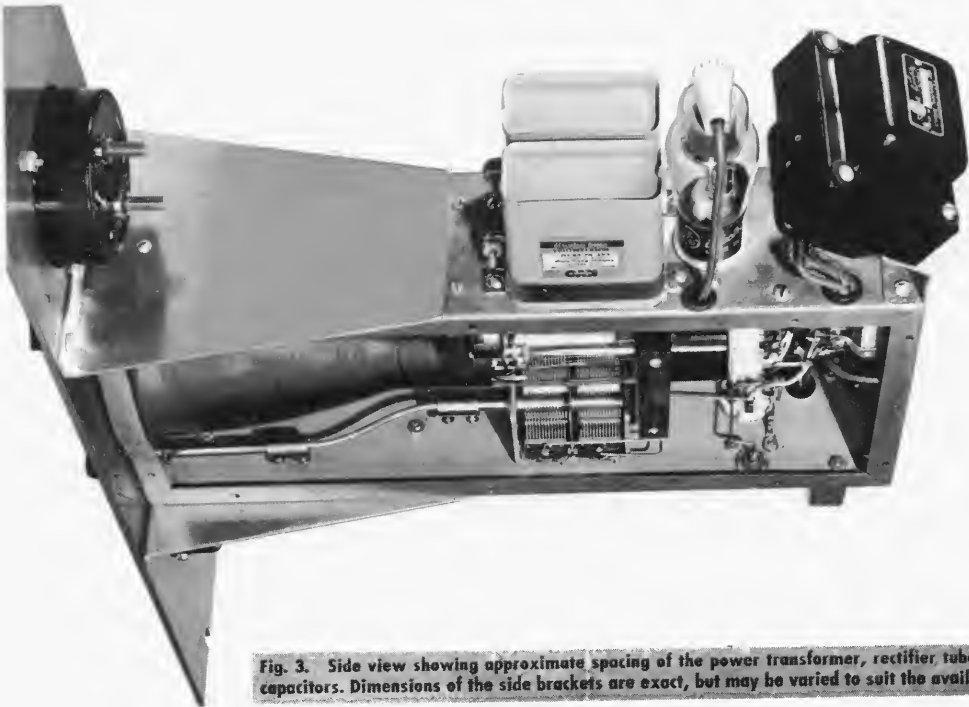

Fig. 3. Side view showing approximate spacing of the power transformer, rectifier tube and filter capacitors. Dimensions of the side brackets are exact, but may be varied to suit the available space.



Fig. 4. View from rear of chassis with C-R tube removed to show 3-inch-square cutout in chassis front wall and bulge in bottom lip.

be bent down to clear the large end of the tube as shown in Fig. 4. With the tube in place, the chassis is positioned behind the panel so that the tube is centered in the meter hole. The chassis top deck measured about 1 inch down from the top edge of the rack panel in the correct position. The $\frac{3}{8}$ -inch diameter chassis holes for the control shafts are now marked on the back side of the panel with a scribe or pencil and matching holes are drilled through the panel in these locations. Large holes for the fuse holder and J_1 , and small holes for the chassis support brackets are also drilled. These brackets, shown in the side view, were made of $\frac{1}{16}$ -inch-thick sheet aluminum and rigidly brace the chassis.

A clamp for the cathode-ray tube base end, pictured in Fig. 5, was fashioned from $\frac{1}{2}$ -inch thick phenolic insulating board. A hole $\frac{1}{8}$ -inch larger in diameter than the tube neck is bored, all small holes drilled, then the board is cut in half at the line indicated on the drawing. Finally, all holes are tapped, except the holes for the clamping screws on the top portion which are redrilled to clear the 6-32 by $1\frac{1}{2}$ -inch-long machine screws which hold the clamp together. Then, cement two strips of $\frac{1}{16}$ -inch-thick sheet rubber into the large hole to act as a cushion for the tube. A sheet aluminum bracket for fastening the power transformer may be fashioned after the proper transformer location has been determined by following the suggestions outlined under "OPERATION." Universal mounting transformers will require a bracket similar to that illustrated in Fig. 2. Upright mounting transformers normally have the bolting flange at the bottom, dictating a shorter type of bracket. Tubular-type filter capacitors with leads

may be substituted for C_1 and C_2 by supporting them on a terminal board which is placed in an unoccupied portion of the chassis. A steatite 4-prong socket for the 2X2A, or octal socket for a 5R4-GY, is preferable to phenolic types because of the fairly high voltage.

The deflection circuit components mount on the opposite side of the chassis. Sweep transformer T_2 was located at the rear corner, also to minimize the effect of its stray fields on the 'scope tube. The plug-in coil socket, J_4 , and the coaxial cable connector, J_3 , may be mounted side by side if L_1 and L_2 are to be wound on molded plug-in coil forms. However, if the larger manufactured air-wound coils specified in the "COIL TABLE" are preferred, additional coil space may be obtained by moving J_4 toward C_3 and centering it vertically on the side wall. The variable capacitor should be a fairly compact unit; otherwise the rotor plates may strike the cathode-ray tube neck when the capacitor plates are about half meshed. If necessary, the tube may be positioned slightly off center in the chassis to obtain this clearance. The capacitor shaft is driven through a panel-bearing and shaft assembly coupled to a 3-inch flexible shaft.

A strip of $\frac{1}{4}$ -inch-thick insulating board, shaped and drilled to dimensions shown in Fig. 6, is a convenient mounting for the "INTENSITY" and "FOCUS" potentiometers, both of which are insulated from the chassis. Insulated couplings, a 3-inch flexible shaft, and a shortened 3-inch shaft and panel-bearing assembly permit operation of the "INTENSITY" control from the front panel. A length of fiber shafting extends the "FOCUS" control to the rear of the chassis, since it

seldom requires adjustment. The voltage divider fixed resistances are fastened to a small terminal board suspended on machine screws, with extra nuts as spacers, just above the cathode-ray tube neck where they may be conveniently wired to the potentiometers.

WIRING DETAILS

Leads from the power connector, J_2 , on the rear of the chassis to S_1 are shielded wire, but all connections except the high-voltage leads are made with conventional hook-up wire. High-voltage wire was used on the rectifier anode, filter capacitor and voltage divider connections. Plastic insulating tubing was slipped over the transformer high-voltage and heater leads for added protection. Connections between the coil socket, variable capacitor and coaxial connector are made with tinned No. 14 copper wire. Leads to S_1 and the "SWEEP" control should be assembled before they are mounted in the rather restricted chassis corners. The cathode-ray tube socket leads should be connected so that pin 1 is *down* for a 3KP1 and have some excess length. For other tube types the pin number denoting the deflection plate axis is placed down.

The power transformer should be temporarily wired into the circuit with all leads left full length and running through rubber-grommets holes in the power supply side wall. The transformer is permanently mounted following preliminary tests, leads are cut to proper lengths and any unused leads are clipped short and taped. Wiring to the fuse holder and J_1 , above the chassis, runs up through rubber grommets placed in $\frac{3}{8}$ -inch diameter holes. Meters inserted in the outside panel holes are wired into the transmitter circuits by direct connection to the meter terminals. The power leads to J_2 may be connected to existing transmitter filament wiring.

OPERATION

After a final wiring check, set the slider on resistor R_1 to 1.5 ohms with an ohmmeter. Lay the power transformer, which is hanging by its leads, about 1 inch from the chassis in the position shown in Fig. 4. Insert the 2X2A rectifier tube, but do not connect its anode cap or plug in the cathode-ray tube at this time. Connect an AC voltmeter to pins 1 and 4 on the rectifier socket, turn S_1 to the "EXT." position and read the heater voltage. If 2.5 volts is not read, *turn off* the power and adjust the slider on R_1 until this voltage appears across the 2X2A socket with power on.

With the power off, connect the anode cap on the 2X2A, insert the cathode-ray tube and clamp it in place. Again turn S_1 to the "EXT." position and turn

the "INTENSITY" control clockwise until a pattern appears on the tube screen. Next, adjust the "FOCUS" control until the pattern resolves into a sharp spot or line. If a line is observed, turn S_1 to the "OFF" position and note whether the line changes to a small spot before it fades from view. If it does, the stray field from the power transformer is deflecting the spot. With S_1 again in the "EXT." position, turn the transformer in various positions until the line reaches minimum length. Leave the transformer in this position and take measurements for the mounting bracket, described under "MECHANICAL DETAILS." Tests with three types of transformers indicate that it should be spaced at least 1 inch from the chassis.

The internal 60-cycle horizontal sweep now can be tested by setting S_1 on the "INT." position and turning the "SWEEP" control clockwise until a full-width line appears on the screen. With the sweep transformer specified in the "PARTS LIST," it should be possible to extend the sweep far beyond the tube face.

An external RF voltage is applied to the "HAMSCOPE" by running a small coaxial cable from J_3 to the device being checked. This cable should terminate in a small coil placed near the output tuned circuit in that device. The loop also may be coupled to the antenna tuning network or *balun* coils used with some transmitters. For convenience in making connections, an extra coaxial cable connector may be added to the unit in which the coupling loop is placed.

After tuning C_3-L_1 to the output frequency, the RF voltage on the vertical deflection plates appears as a band across the C-R tube face. Maximum height of this pattern can be set by adjusting the coupling loop; then the C_3-L_1 tank can be detuned to reduce the vertical deflection if desired. A wide pattern is developed on a 3KP1 even from the low output of a grid-dip oscillator coupled to the tuned circuit, indicating good deflection sensitivity. The width of this pattern will vary in accordance with the modulation applied to the transmitter. A detailed description of the patterns obtained from amplitude- or frequency-modulated, and single-sideband-suppressed-carrier transmitters will be found in amateur radio handbooks and magazine articles covering these forms of modulation.

Final dressing up includes: adding control knobs which match those in your station; marking these controls with *decal* labels; cementing a bezel made from $\frac{1}{4}$ -inch-diameter plastic tubing around the C-R tube opening; and fitting a perforated sheet aluminum chassis bottom plate to the underside of the "HAMSCOPE."

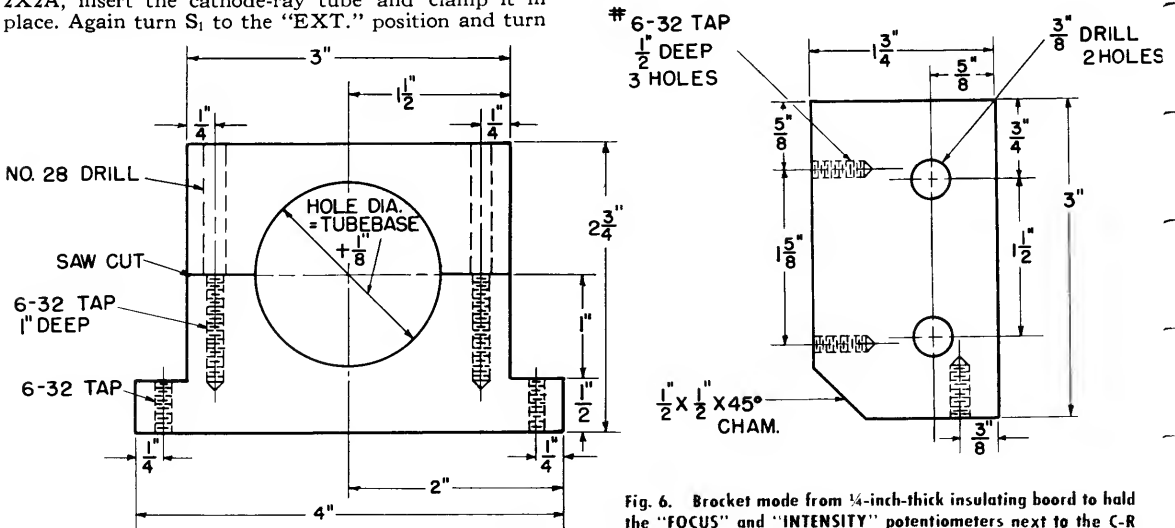

Fig. 5. Mounting bracket for C-R tube base made from $\frac{1}{2}$ -inch-thick phenolic insulating board or similar material.

Fig. 6. Bracket made from $\frac{1}{4}$ -inch-thick insulating board to hold the "FOCUS" and "INTENSITY" potentiometers next to the C-R tube neck. Mounting holes may be first drilled in the chassis, then marked on both brackets.

Other Ideas for the Hamscope

1. Several cathode ray tube types other than the 3KP1 tube recommended for the HAMSCOPE may be used if the changes listed below are followed.
2. For cathode ray tubes having the cathode connected internally to one side of the heater, (3AP1, 3CP1, 3EP1, 3GP1, 5AP1, 5BP1, 5GP1, 5HP1, 5JP1, 5NP1)
 - a. Connect the end of the 1-megohm resistor shown running to the cathode, pin 3, to one side of the tube heater circuit instead.
 - b. The cathode ray tube control grid should be connected to the negative side of the high voltage supply, as shown for the 3KP1, but the negative high voltage circuit should not be connected to one side of the heater circuit. This circuit is shown below.
3. The additional deflection plate shown on the basing diagram for a 3CP1 type cathode ray tube is an accelerating anode and should be operated at the same DC potential as the deflection plates. In the HAMSCOPE, ground this pin.
4. When a 5-inch cathode ray tube is operated in the HAMSCOPE circuit, it is recommended that at least 1000 volts DC be applied across the voltage divider
5. Cathode ray tubes which have one horizontal and one vertical deflection plate connected together and brought out to a common connection require some changes in the HAMSCOPE deflection circuit.
 - a. The pair of deflection plates connected to one pin should be grounded.
 - b. One end of the secondary winding on T_2 is grounded, and the other end is connected to the remaining horizontal deflection plate.
 - c. A single gang 365-mmf variable capacitor is substituted for the two-gang type specified for C_3 and the rotor is grounded. The stator on C_3 is connected to the remaining vertical deflection plate, and to pin 4 on J_4 .
 - d. Coil L_1 is wound with no center tap, and is connected between pins 3 and 4 on J_4 . The center tap on commercially made coils is not used, and the connection from pin 3 to ground on J_4 is removed from the circuit. Pin 2 on J_4 should then be grounded. This circuit is shown below.
6. In the wiring shown in Fig. 1 on page 3 of the September-October, 1957 issue, the schematic diagram for the plug-in coil form is correct, but the pins are numbered wrong, and should be numbered as shown for J_4 in that diagram.
7. Cathode ray tubes having short persistence green, blue or white screens (P1, P4 and P11) will work best in the HAMSCOPE, but medium and long persistence screens (P7 and P 4) are useful for checking a transmitter modulated by a steady audio tone. The P7 and P14 screens will retain a pattern too long to be very useful for continuously monitoring a voice-modulated transmitter, however.
8. Technical data sheets for several types of G-E cathode ray tubes are available, as listed below. These sheets may be obtained by writing to: Technical Data Section, Cathode Ray Tube Department, General Electric Co., Electronics Park, Syracuse, N. Y. These types are: 2AP1-A, 2BP1, 3AP1-A, 3BP1-A, 3KP1, 3MP1, 5AUP24, 5CP1-A, 5QP4-A, 5UP1, 14UP4.
9. Technical data for the above types, and for other types of cathode ray tubes, can be found in the ARRL Radio Amateur's Handbook. Look in the tube technical data chapter, under "Cathode Ray Tubes."

10. A number of readers have inquired about converting the war surplus BC-929 oscilloscope to the HAMSCOPE circuit. An article has been published in QST magazine for August, 1957, page 32, describing the conversion of this oscilloscope to a modulation monitor similar to the HAMSCOPE, but with more elaborate circuits.

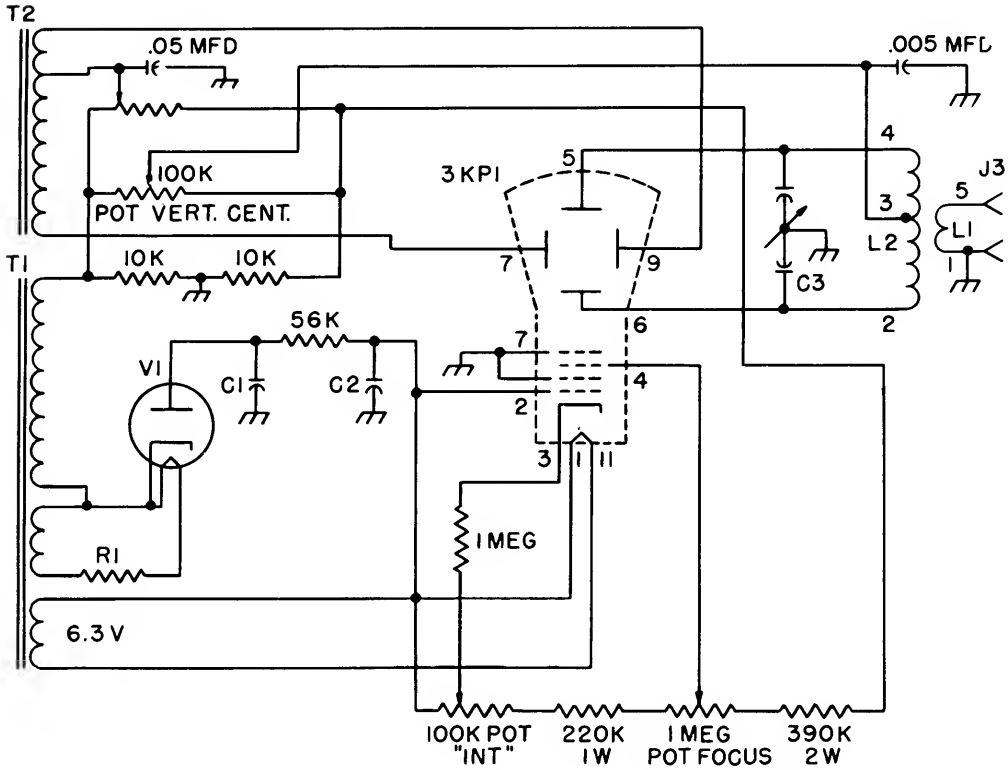

DIAGRAM SHOWING CIRCUIT CHANGES TO ADD CENTERING CONTROLS TO THE HAMSCOPE.

DEFLECTION CIRCUIT CHANGES FOR C-R TUBES HAVING TWO PLATES ON ONE BASE PIN

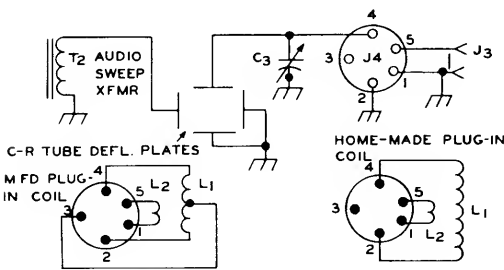

DIAGRAM SHOWING CHANGES IN HAMSCOPE CIRCUIT FOR C-R TUBES WITH CATHODE TIED INTERNALLY TO ONE SIDE OF HEATER.

CIRCUIT CHANGES FOR C-R TUBES HAVING CATHODE TIED TO HEATER INTERNALLY

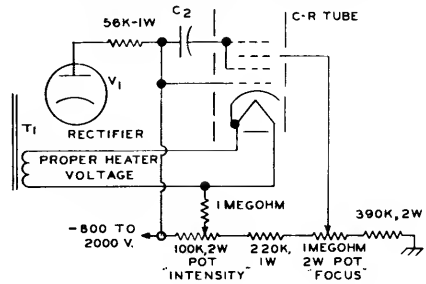

DIAGRAM SHOWING CHANGES IN DEFLECTION CIRCUIT FOR C-R TUBES HAVING 2 PLATES CONNECTED TOGETHER AND BROUGHT OUT TO ONE BASE PIN.

USING THE HAMSCOPE

Two types of patterns, wave envelope and trapezoidal, normally are used for checking AM or SSB transmitter modulation with an oscilloscope. The "HAMSCOPE" will present a wave envelope pattern simply by feeding the transmitter RF output into the vertical deflection circuit through J_3 and turning S_1 to the "INT." position. Modulation of the transmitter either by voice or an audio tone will cause the RF carrier band on the screen to vary in height. The pattern may move across the screen or remain stationary if the modulating frequency is an exact multiple of the 60-cycle horizontal sweep frequency.

When a trapezoidal-type test pattern is desired, an amplitude-modulated transmitter output is applied to J_3 , but S_1 is turned to the "EXT." position. An audio voltage which is in phase with the audio being applied to the modulated amplifier stage is fed into J_1 . With the transmitter unmodulated, no horizontal sweep appears, but the RF output is indicated by a vertical line. Applying 100-percent modulation should result in the usual trapezoidal pattern. Any phase difference between the sweep and modulator audio will cause oval-shaped traces to appear along the upper and lower edges of the trapezoid. This condition may be corrected by installing a 500-mmf capacitor and a 0.5-megohm potentiometer in series with the ungrounded audio lead to the "HAMSCOPE."

The modulation transformer secondary in plate, screen or control-grid type modulators, and the plate of a clamp-tube modulator, are suitable points to connect one end of a voltage divider from which the audio sweep voltage for the "HAMSCOPE" is obtained. This divider should include a: (1) coupling capacitor, (2) fixed resistance and (3) potentiometer, series-connected in that order between the tap-on point and the chassis. Suitable values for these components are:

(1) capacitor, 0.005-mfd per megohm of total divider resistance; (2) fixed resistance, 1 megohm per 1000 volts DC potential at the tap-on point; (3) potentiometer, 0.1 megohm. The capacitor should have a working voltage rating equal to 2.5 times the DC voltage, and the fixed resistance should have one resistor for each 500 volts at this point. Audio is fed from the potentiometer arm to J_1 through a shielded cable.

Audio sweep voltage for checking single-sideband transmitters with a trapezoidal pattern on the "HAMSCOPE" may be taken from the output of the separate audio amplifier stage for the voice-controlled break-in circuit with which most SSB exciters are equipped.

RANDOM IDEAS

A smaller chassis, 5 by 10 by 3 inches, may be chosen for a "HAMSCOPE" built around a 2-inch or one of the short 3-inch cathode-ray tubes (3MP1, 3UP1). In this narrower chassis, the tube still should be placed 3 inches from the power supply wall of the chassis. The variable capacitor should be mounted outside the chassis, preferably in a small box, which also could house the plug-in coil socket. The shorter chassis also permits locating the power transformer directly behind the cathode-ray tube base where it is less likely to cause stray deflection effects. Another variation is to select a chassis large enough to also enclose the meters on the panel, which gives the constructor space to add future accessories to the basic 'scope circuit.

If your meter panel has three holes for 2-inch meters, a "HAMSCOPE" using a 2-inch cathode-ray tube may be constructed in a chassis up to 7 inches wide. The "HAMSCOPE" also may be adapted for table mounting by selecting a utility cabinet proportioned to house all components. Again, the principal design problem is locating the power transformer where its stray field does not affect the cathode-ray tube operation.

BIBLIOGRAPHY OF MODULATION WAVEFORM PATTERNS

Amplitude-modulated patterns:

1. The Radio Amateur's Handbook, 1960 edition, "Amplitude Modulation" chapter, pages 297 - 301.
2. The Radio Handbook, 15th Edition, "Amplitude Modulation" chapter, page 290; "Sideband Transmission" chapter, page 330.
3. QST, "Some Principles of Radiotelephony", Part I, May, 1954, page 37; Part II, June, 1954, page 13; Part III, July, 1954, page 34; Part IV, October, 1954, page 22.

Single-Sideband patterns:

1. The Radio Amateur's Handbook, 1960 edition, "Sideband" chapter, pages 309, 315-319 (Also, "Single Sideband for the Radio Amateur", pages 109, 112, 132, 135-139, 141).
2. New Sideband Handbook, "Linear Amplifiers" chapter, pages 151, 152.

Double Sideband patterns:

1. CQ, "DSB Considerations and Data," October, 1957, page 64.
2. CQ, "Modulating the DSB Transmitter," March, 1958, page 32.
3. New Sideband Handbook, "Double Sideband" chapter, page 136.

Replaces the Antenna Relay in 50-ohm Coaxial Cable Antenna Circuits

From May-June, 1953



Here's the answer to the prayers of many a ham—an electronic circuit without switches or relays that permits a receiver to remain permanently connected to a transmitting antenna without damage to the receiver when the station transmitter is turned on.

The Dioplex taps into the transmission line and permits low-level incoming signals to pass into the receiver. However, when the transmitter is operating, the relatively high level signal voltage which appears on the line activates the Dioplex in such a way that the path to the receiver is blocked. Two words of caution at the outset: The unit is designed for 50-ohm coax; and as the operating frequency increases, the power-handling capacity of the Dioplex rapidly drops off. Of course, 80-meter boys are limited to 5000 watts!

—Lighthouse Larry



Fig. 4—Components of Dioplex mounted in space-saving arrangement

The Dioplex is a device for connecting a receiver to a transmitting antenna to obtain the advantage of as good an antenna for receiving as for transmitting. This is accomplished without moving parts—no relays with their clatter and possible erratic contacts to cause unexpected trouble. Since the action of the Dioplex not only is silent but instantaneous and positive, the receiver input circuits are afforded an even higher degree of protection from accidental or inadvertent damage than when a separate receiving antenna is used.

The Dioplex is used between a low impedance transmission line and the receiver as shown in Figure 1. With input and output impedances of 50 ohms, it is

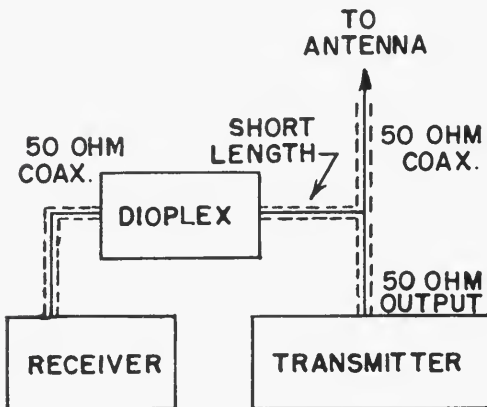

Fig. 1—How the Dioplex is connected

capable of protecting the receiver in accordance with the data in Table II. These figures are RF output—not d-c input. In most cases the allowable d-c input to the transmitter will be slightly higher. How much

higher will depend, of course, on the efficiency of the final stage of the transmitter.

It is fortunate that at low frequencies where the receiving insertion loss is greatest, the practical effect on the received signal, though measurable, is still negligible. It is unfortunate, however, that the continuous power rating drops so rapidly with increasing frequency, and that the transmitting insertion loss, while constant, becomes a greater percentage of the permissible transmitter output.

CIRCUIT DETAILS

The complete circuit diagram for the Dioplex is shown in Figure 2. The input goes from a coaxial connector to a plug-in coil. Two biased 6X4 diodes operated back-to-back serve as a voltage-sensitive shunting element. Also, half of one of these tubes is used as a 60-cycle half-wave rectifier to provide diode bias from the transformer. The two selenium rectifiers serve merely as bias voltage stabilizers. The bias will be .om 2 to 2.5 volts on each diode. A 3–30 micro-microfarad mica trimmer is used to compensate for variations in the internal tube capacities plus strays. Those interested in a more detailed description of the operation of the Dioplex are referred to the section headed "Thumbnail Theory."

CONSTRUCTION DETAILS

All components of the Dioplex except the transformer are mounted on one of the removable 4 x 5-inch plates of a Bud 3 x 4 x 5-inch utility box. The tube sockets are mounted on an L-shaped bracket that can be simply made of $\frac{1}{8}$ -inch aluminum. Before the coil sockets and coaxial connectors are mounted, the paint should be scraped from the plate to assure good grounding. If sockets with built-in by-pass condensers are used (as in the model shown), the by-pass straps should be removed from pin 1 of V_1 and from pin 7 of V_2 , since these points operate at RF potential. With ordinary sockets, ceramic by-pass condensers should be installed as close to the socket terminals as possible.

The transformer is mounted in the center of one of the 3 x 5-inch sides of the utility box with the leads from the secondary windings brought inside through a rubber grommet. The primary leads are left free for connection to the 110-volt a-c line. No switch is provided, since accidental damage to the Dioplex and possibly to the receiver can occur if the 6X4 tubes are not energized when transmitting.

Although wiring is not critical, a piece of tinned No. 14 wire is arched between the coil sockets. Keeping this lead in the clear reduces stray capacity and provides an easy method of connecting the plate of V_1 , the cathode of V_2 , and the "stator" of the mica compression trimmer. The "rotor" of the trimmer is bolted to the L-bracket next to the tube socket as shown so as to provide easy access to the adjusting screw through a $\frac{1}{4}$ -inch hole drilled in the top plate. Tinned No. 14 wire also is used to ground the unused pins on the coil sockets, thus providing a measure of

shielding.* Insulated wire is used for the other connections.

The high voltage and filament leads from the transformer—connected last—are left their original length and looped around inside the box after the top plate is attached. This makes it easy to remove the top plate should occasion rise.

COIL DATA

All coils are wound on Amphenol polystyrene 5-pin coil forms $\frac{3}{4}$ inch in diameter and $1\frac{1}{8}$ inches long. Two identical coils are required for each band. Winding data is given in Table I. Since none of the windings is more than 1 inch long, the bottom turns can start $\frac{3}{8}$ inch from the base of the forms. In each case, the

* Some eagle-eyed readers may notice that six-hole sockets are used in the model illustrated. This is because they were at hand when this unit was built. The Amphenol 24-5H plug-in forms fit in the six-hole sockets made for the 24-6H coil forms.

bottom of the coil winding should connect with pin 3 of the plug-in form and the top of the winding with pin 1—thus providing the widest possible separation at the coil socket. If the winding information is followed closely, it should not be necessary to reset the trimmer condenser when changing bands. The turns should be sealed on the forms with Duco or G-E Glyptal No. 1286 cement. The end turns on each coil should be cemented all the way around the form, and then four strips of cement can be run lengthwise at 90-degree intervals to hold the entire winding in place.

Since polystyrene melts at a relatively low temperature, caution is advised in soldering the coil ends to the pins. The inside of each pin to be soldered should be reamed clean with a drill and a hot iron used just long enough to flow the solder into the pin tips.

GENERAL INFORMATION

It is necessary to assure that a d-c circuit path is

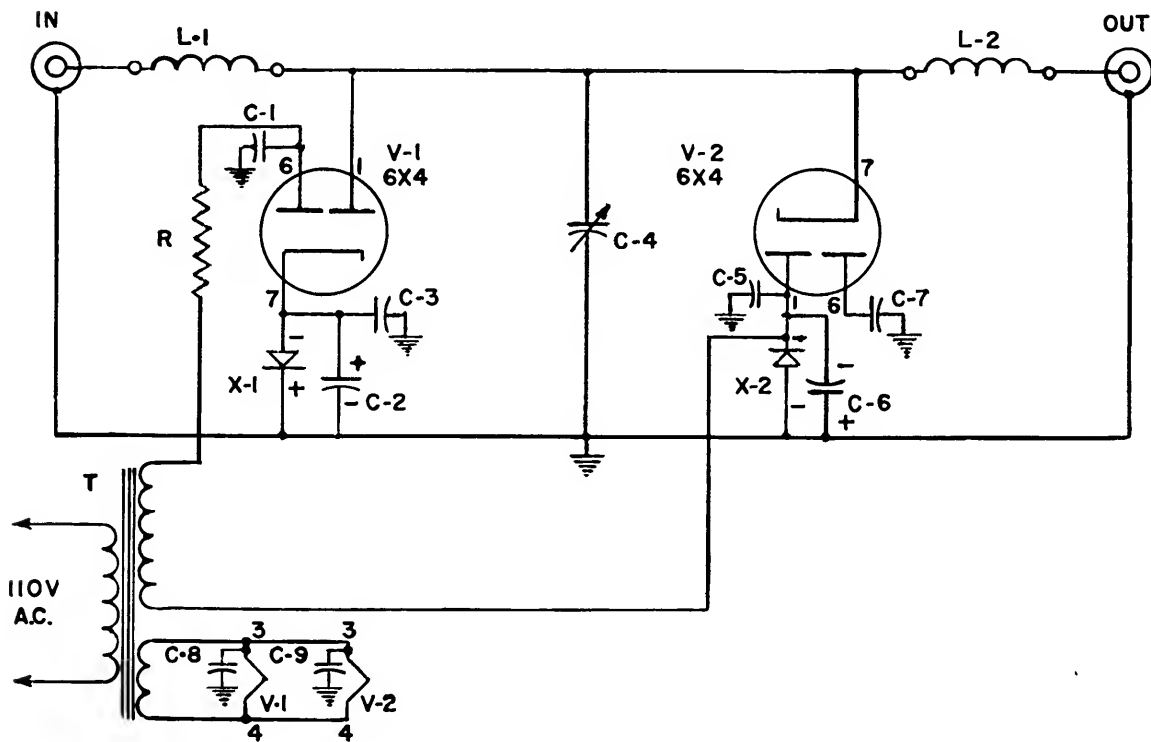

Fig. 2—Circuit diagram of the Dioplex

C₁, C₃, C₅, C₇, C₈, C₉—0.001 mfd ceramic bypass
 C₂, C₆—50 mfd. 50-volt electrolytic
 C₄—3–30 mmf mica compression trimmer
 L₁, L₂—(See text and Table I)

R—33,000 ohms, 1 watt
 X₁, X₂—100 ma, 380-volt selenium rectifier (GE-5GH1)
 T—Power transformer: Pri. 117 V 60 cy; sec. 117 V $\frac{1}{2}$ wave @
 50 ma d-c, 6.3 V @ 2 A (Stancor PA8421)

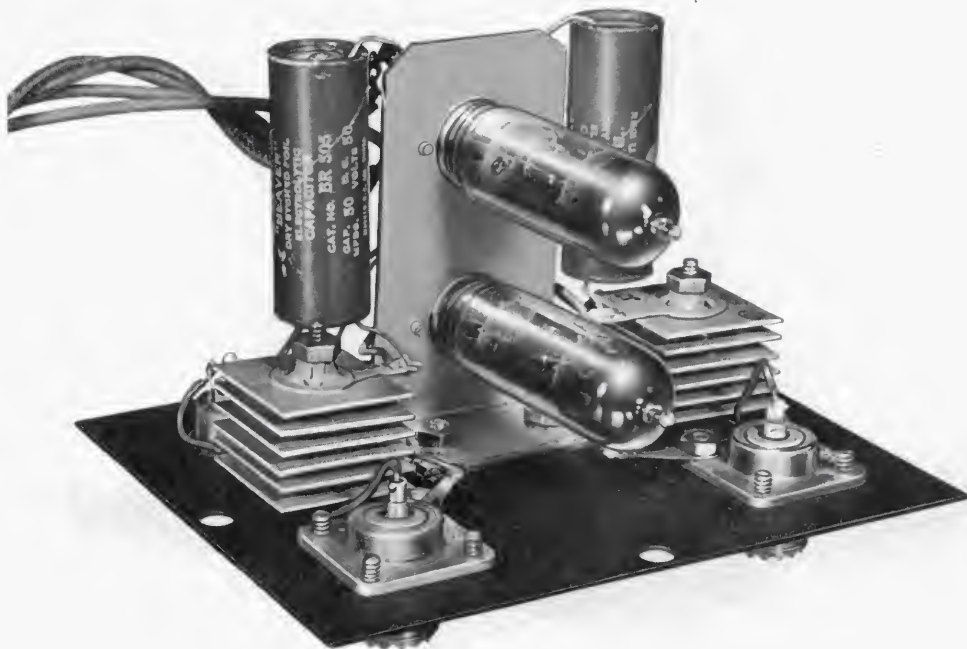

Fig. 3—The 6X4 diodes are mounted on a simple L-bracket

maintained between the coils and the chassis of the Dioplex. Ordinarily, the input coil of the receiver or the output link of the transmitter provides this path through the coax braid. In doubtful cases, this can be checked with an ohmmeter and if no d-c connection exists, a 2.5 millihenry pie-wound RF choke should be placed across one of the coaxial connectors of the Dioplex.

Since the Dioplex design is based on 50-ohm receiver input impedance, deviation from this value will affect principally the amount of power dissipated in the receiver when the transmitter is operating. If there is doubt about the input impedance of the receiver, a 51-ohm 1-watt resistor may be placed across the output connector of the Dioplex to assure that the combination of this artificial load and receiver never exceeds 50 ohms. In most cases, this shunting resistor will not degrade receiver performance.

The power ratings in Table I apply only when the input to the Dioplex—that is, the side that connects to the transmission line—is across a 50-ohm circuit. Simply using 50-ohm coaxial transmission line is not enough to assure that this condition exists unless the standing wave ratio on the transmission line is close to unity. The important consideration here, as far as the Dioplex is concerned, is that the RF voltage applied by the transmitter must not exceed 500 volts at 3.5 mc, 250 volts at 7 mc, 125 volts at 14 mc, 80 volts at 21 mc, and 56 volts at 28 mc. Keeping within these ratings will prevent a receiver from being burned out due to tube failure caused by overload.

The effect of a transmitter connection across the receiver input can be troublesome if the transmitter

output stage is not biased beyond cutoff during reception. And with the Dioplex in place, the coupling between transmitter output stage and receiver is very good indeed for low-level extraneous signals sometimes generated in a transmitter that normally is considered "off." Operators of single-sideband stations know that an active output stage coupled to the antenna can cause local receiving difficulties. These difficulties will be greatly magnified with the Dioplex. Blocked-grid

TABLE I—COIL DATA

All coils wound with enamel or Formex insulated wire on $\frac{3}{4}$ -inch plug-in forms (Amphenol 24-5H).

Band	Wire Size	No. of Turns	Length of Winding	Inductance (milli-henries)
3.5	#32	110*	1 in.	0.125
7	#26	57*	1 in.	0.035
14	#19	29*	1 in.	0.00875
21	#19	20**	1 in.	0.004
28	#19	13**	$\frac{3}{4}$ in.	0.0022

* Close-wound.

** Spaced.

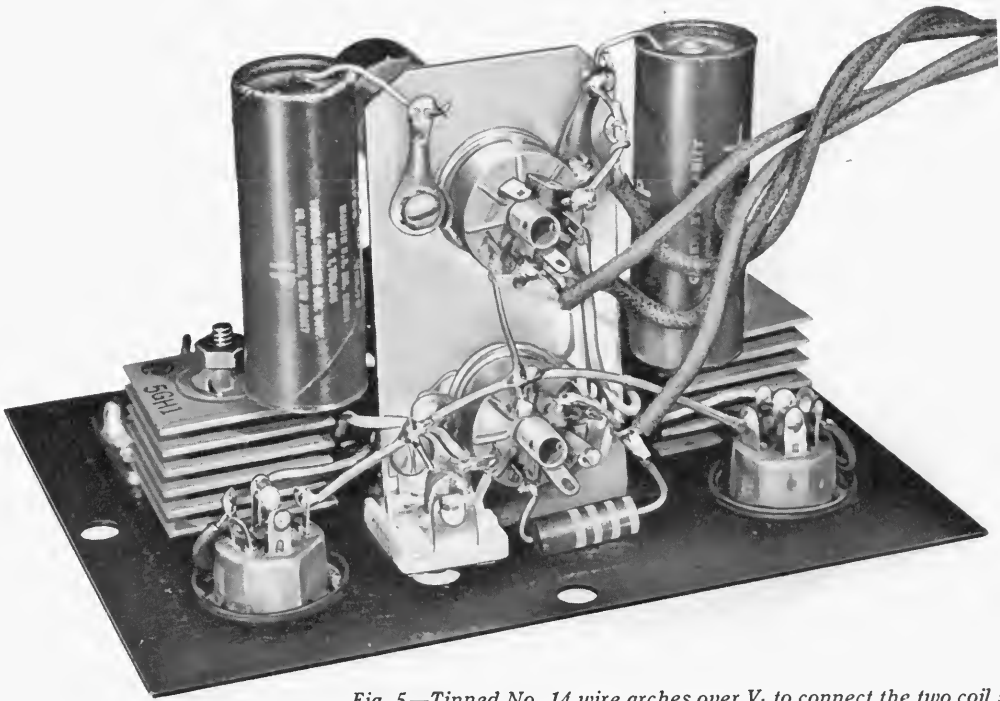

Fig. 5—Tinned No. 14 wire arches over V_1 to connect the two coil sockets

CW keying circuits or sufficient protective fixed bias on the output stage of the transmitter should prevent such troubles.

Note the polarities of the electrolytics and selenium rectifiers in the schematic. The cathode of V_1 should be positive with respect to ground, while plate 1 of V_2 should be negative with respect to ground. Thus the polarities indicated on the electrolytic condensers are correct. The selenium rectifiers are connected "backwards" to provide a stiff diode bias source without using much standby power. The GE-5GH1 rectifiers are marked with a red dot on one pole which in this case is connected where the plus signs are marked in the schematic. The d-c voltage across the electrolytic condensers should be checked before using the Dioplex to make certain only about 2 or 3 volts bias appears when the tubes warm up. Much more bias than this indicates either that the selenium rectifier connections should be reversed, or the rectifier is defective.

While in most applications the bias provided will be ample to prevent diode conduction during reception, exceptionally strong incoming signals reaching the Dioplex can cause cross-modulation. If this problem is encountered, two selenium rectifiers can be wired in series where one now is called for in the schematic. The bias then should be from 4 to 6 volts d-c on each 6X4 tube.

One final but important bit of advice. The transmitter never should be operated without the 6X4 tubes in place and the Dioplex energized. The primary of the Dioplex transformer can be connected in parallel with the primary of the filament transformer for the transmitter's output tube or tubes—thus assuring

that a major part of the transmitter output will not be dumped into the receiver. Always use the coils for the band on which the transmitter is operating.

INSTALLATION AND OPERATION

As indicated in Figure 1, the lead from the transmission line to the Dioplex should be as short as practical. This connection can be made with one of the coaxial T-connectors, or the Dioplex input can be connected directly on the transmitter output terminals if that method is more convenient. The cable from Dioplex to receiver can be any convenient length. With the transmitter off, the proper Dioplex coils in place and the 6X4 filaments warmed for at least 30 seconds, the mica trimmer should be adjusted for best received signal strength near the high portion of the band. The same adjustment should hold for all bands. The Dioplex can, of course, be peaked for a favorite frequency.

Never attempt to run more than 5000 watts output on CW, AM or NBFM or 10,000 watts peak output on SSB on 80 meters! Similarly, keep within the ratings of Table II on other bands.

THUMBNAIL THEORY

The Dioplex is based on the principle of radar's "T-R box," using lumped-circuit constants instead of the transmission lines or waveguides common in radar techniques. A better description might be that the Dioplex is electrically a half-wave filter similar to the Harmoniker (G-E HAM NEWS, Vol. 4, No. 6, Nov.-Dec. 1949). But while best operation of the Harmoniker requires a reasonable impedance match,

the Dioplex accomplishes its purpose by means of deliberate mismatch. In fact, the greater the degree of mismatch in this application, the better protection to the receiver.

A half-wave filter such as the Harmoniker effectively is "not in" a circuit of any impedance at the half-wave frequency. In describing the Harmoniker, a curve was given showing how the voltage on the center condenser varied with mismatch. The Dioplex takes advantage of this phenomenon so that a relatively light-duty short-circuiting device across the center condenser can thwart the efforts of a kilowatt rig to get into the receiver through the antenna terminals.

By placing biased diodes back-to-back across the center condenser of the half-wave structure, small signals do not cause conduction in the diodes—and the receiver is connected to the antenna feedline through the half-wave filter. However, when a signal from the transmitter appears across the input to the filter, the diodes become conducting and the receiver is substantially (but not entirely) isolated from the input. At the center condenser, the transmission line voltage is magnified by a factor approximately equal to the

ratio of the reactance of one of the coils to the resistance of the load until conduction commences in the diodes. At this voltage, and at any higher input voltage, the magnification ceases and a current flows through the input coil into the diodes which have a net forward resistance of about 400 ohms.

Thus the device becomes a voltage divider of two stages—the first stage being the reactance of the input coil and the diode forward resistance, while the second stage consists of the reactance of the second coil and the input impedance of the receiver. Simply stated, then, the design objectives are: (1) As high a coil reactance as practical, (2) as low a diode forward resistance as possible, and (3) a relatively low load impedance.

These objectives place certain restrictions on the application of the Dioplex, and in effect limit its practical realization to low-impedance receiver input—from 50 to 300 ohms or so—and to operation in a low impedance point in the transmission line feeding the transmitter output to the antenna. This system works out nicely for 50-ohm coaxial circuits, and the design given for the Dioplex is for this application.

TABLE II—PERFORMANCE DATA

Band	Transmitter Output (watts)		Voltage at Receiver*	RF Input to Receiver* (watts)	Insertion Loss*	
	Cont. (Col. 1)	Peak (Col. 2)			Rec'g (Col. 5)	Xmt'g (watts) (Col. 6)
3.5	5000	10000	1.25	.03	6 DB	10
7	1150	10000	2.2	.1	3 DB	10
14	290	4500	4.5	.4	..**	10
21	130	2000	6.4	.85	..**	10
28	64	1000	8.5	1.45	..**	10

NOTES

Col. 1—Determined by the safe continuous diode current.

Col. 2—Based on maximum safe input voltage, or an average duty cycle of one-quarter (whichever is lower) in the case of single-sideband suppressed carrier operation.

Cols. 3 & 4—Based on continuous CW, AM or NBFM output delivered to a 50-ohm receiver input. The RF power actually delivered to the receiver (Col. 4) will vary in direct proportion with the continuous transmitter output (Col. 1) in each band—i.e., 145 watts continuous output at 14 mc. would deliver .2 watt to receiver.

Col. 5—Based on a coil Q of 100. Coils in unit described have a Q of about 150, so this rating is conservative.

* Approximate.

**Negligible.

Inverted Speech Tricks That Can Be Performed with a Single Sideband Generator and Receiver. Here's an interesting demonstration that can be performed before amateur radio clubs and other groups by someone who is willing to do an hour or two of rehearsal in advance. In fact, it would make an entertaining program to hold a contest among members at some club meeting to see who can talk in inverted speech the best!

I recently had the pleasure of addressing the Evansville-Owensboro Section of the Institute of Radio Engineers. My subject was the SSB Jr. rig described in this issue of the *Ham News*. D. E. Norgaard, W2KUJ, had also been invited to talk to this group, but he was unable to appear, so I made a wire recording of Don's talk and took it along with me.

Whenever Don or I give talks on single-sideband we like to demonstrate inverted speech, because it is so easy to produce with SSB equipment. As you know inverted speech is that strange sounding stuff that you hear on the short-wave bands on transoceanic communication systems. At least, inverted speech used to be used a great deal, although now more complicated systems of scrambling are employed.

At any rate, you produce inverted speech by taking an upper sideband, let us say, and placing it on the low frequency side of a carrier. This can be done on a receiver by tuning it on the high frequency side of a so-called upper sideband. The effect is to make low pitched sounds high in pitch and vice versa. You should hear the wolf-whistle coming through on inverted speech! I can guarantee that you would never recognize it.

In fact, until you become familiar with inverted speech it is practically impossible to recognize any-

thing. For example, if you say "General Electric Company" into an inverted speech system, what comes out sounds like "Gwunree Oyucktruck Krinkino." Conversely, if you say the latter phrase into an inverted speech system, what comes out sounds like "General Electric Company."

In other words, you can form a new language, and if you speak this new language into an inverted speech system, what comes out is understandable English. As an example, "metz pee wee" means "nuts to you" and "eee wye" says "oh yeah." But you can go even further, as Don and I did. We decided that it would be nice to be able to recite the poem *Mary Had A Little Lamb* in inverted speech, and after an hour of intense concentration we succeeded in the decoding job.

We thought you would like to see this poem in "Sweeping the Spectrum," so here it is:

Naarow hod O yutty yarng,
Uts feious yiz yelt-uz snee,
Arnd I view hair naarow yump,
No yarng yiz sla pee bay.

A word of caution. When practising this poem in inverted speech language, make sure that you are alone. People have strange enough ideas of amateurs as it is!

AUDIO ACCESSORIES FOR SIDEBAND

RESTRICTING FREQUENCY RANGE IN TRANSMITTER AUDIO SYSTEMS

From July-August, 1949

TECHNICAL TIDBITS

RESTRICTING SPEECH RANGE IN SPEECH AMPLIFIERS

Note: The following article was prepared for publication before the April 27 FCC proposals regarding restricted bandwidth were made public. The attenuation of unwanted audio frequencies as discussed in this article is in the order of 12 db per octave. Because the FCC has given no details of the attenuation they consider necessary, there is no way of knowing whether 12 db per octave will be considered adequate.

This is a case of where you can get something for nothing, or at least, close to nothing. Before giving the punch line, though, let's examine the situation from the beginning.

Phone stations on the ham bands seem to fall into three categories regarding their speech quality. The first are the stations that will have no audio equipment in the shack unless it is capable of a flat response from 20 cycles to 15,000 cycles. Their quality is superb, and your ears would tell you so if it were possible to have a receiver and a reproducing system capable of handling this audio range at a time when propagation conditions allowed undistorted reception. These amateurs are taking up needless space in the limited ham spectrum by their activities, but as long as their carrier is inside the band edge by twenty to twenty-five kilocycles (in order to keep those wide sidebands inside the band) then, the FCC will not bother them, at least not yet.

On the other extreme is the second group, small though it be. These amateurs wish to have a transmitter that is as effective, communication-wise, as possible. Those who are on AM phone tailor their speech amplifier equipment until it transmits the narrowest possible audio range, leaving only enough audio range for complete understandability. A more rabid group goes even further, by partially eliminating the carrier and then transmitting only one sideband. These amateurs deserve a lot of applause, but we needn't bother to applaud them, because they did this not for applause but because they want their money's worth out of their equipment.

Which brings us to the third group, which must certainly include the majority of the world's phone men. This group is made up almost entirely of Mr. Average Phone Man and others of his ilk. Mr. Average Phone Man has a speech amplifier and a modulator which he copied faithfully from some handbook or some radio magazine. When he finished the audio end, he connected it to his c-w rig, got on the air, and asked the first ham he contacted the age-old question "How's my modulation?" Aside from the

fact that Mr. Average Phone Man should have checked his modulation with a scope, while transmitting into a dummy load, instead of depending on the advice of another Mr. A. P. M., this situation is quite normal and is to be expected.

All right, you say, this is old stuff, so where's the pitch? Here it is. Why continue to waste power by transmitting certain audio frequencies if these audio frequencies are unable to help the other fellow hear you, especially when you can almost get rid of these unwanted high and low frequencies at practically no cost? To be specific about cost, the change can be made by the use of four 600 volt paper or mica condensers.

Before explaining how and where to put which condensers, let's make certain that another point is clear. This article has nothing to do with speech compressors, speech clippers, or sharp cutoff low-pass filters. The latter will do an excellent job of tailoring the speech range, but these filters may be rather elaborate. Speech compressors and speech clippers, on the other hand, do not affect in any way the band-pass characteristics of an amplifier unit. They may, however, affect the fidelity from a distortion standpoint. This is especially true of speech clippers.

One other point might also be explained here. The changes to be described are suitable for practically any type of speech amplifier. However, a restricted bandwidth is not assured if these changes are made in an amplifier which is used for NBFM. If the swing is not carefully adjusted the bandwidth may still be excessive. In other words, it is worthwhile to make these changes in an NBFM speech amplifier, but the effect will be nullified if the signal is permitted to swing too far frequency-wise, due to improper adjustment.

Here, then, is what you may do to restrict the audio range of your speech amplifier in an economical way. First, attenuate the low audio frequencies by changing the value of two of the interstage coupling condensers and second, attenuate the high audio frequencies by adding a condenser from plate to ground on two of the audio stages.

The calculations to determine the proper size of condenser for each point are not difficult. It is first necessary to decide on the audio range you wish to cover. Let us assume that you want an audio characteristic which is down somewhat at 300 cycles on the low end and 3500 cycles on the high end. To be more exact, this is one which will be down 6 db at

300 and 3500 cycles, when changes are made to two of the stages. These two frequencies—300 and 3500 cycles—will be used in the calculations.

The next step is to examine the circuit diagram of your speech amplifier. Most amplifiers consist of a pentode preamplifier, driving a triode or pentode amplifier, driving a phase inverter or transformer coupled amplifier which in turn drives the output stage. We are interested only in the first two tubes. We want to put a condenser from the plate of the first tube to ground, and one from the plate of the second tube to ground. Also, we wish to change the values of the condensers which are between the plate of the first tube and the grid of the second tube, and between the plate of the second tube and the grid of the third tube.

If the third tube is a phase inverter, it is best not to attempt to change the coupling condenser between the second and third tubes. The reason is beyond the scope of this article but it might be necessary to change the grid circuit of the phase inverter in order to get the proper effect from the changed coupling condenser. In this case, the coupling condenser can be changed between the microphone and the input tube. This is completely satisfactory if a dynamic microphone is used. If a crystal microphone is used, a different approach is necessary. Again this is not within the scope of this article, so that you will have to be satisfied with changes on only one tube, instead of two.

The final step before starting the calculations is to check the value of the grid resistor to which the new coupling condenser will connect. This will be the grid resistor for the second and third tubes unless, as stated above, it is necessary to put one coupling condenser between microphone and grid, in which case examine the grid resistors for the first and second tubes. These resistors should be no greater than 250,000 ohms. If they are of a greater value, decrease them so they are 250,000 ohms or less. Incidentally, the grid resistor for the second tube is usually the gain control.

The proper value of coupling condenser will now be one whose capacitive reactance, at 300 cycles, is equal to the grid resistance in the grid circuit of the stage to which it connects. These words mean, simply, that the condenser value in micro-farads is equal to: $\frac{1,000,000}{(1884)(RG)}$ where RG is the value of the grid resistor in ohms. This assumes that the low frequency point selected was 300 cycles. The figure of 1884 is 300 times 2 times π . As an example, if the grid resistor is 250,000 ohms, the condenser should be 0.0021, so use a 0.002 mf condenser. Make this calculation for both stages, and replace your present coupling condenser with the calculated value of condenser if it is not already that value. The low frequency audio tones are now taken care of.

Before starting the calculation of the plate to ground condensers, find out the plate resistance (RP) of the two tubes involved. Most handbooks have this figure. Next, check the circuit diagram and get the value of the plate load resistor which you are using. This is the resistor which connects directly to the plate at one end and is bypassed to ground (and connects to B plus) at the other end. Next, get the value of grid resistor on the tube which follows the tube whose value of RP you just looked up. Now, calculate the effective parallel resistance of these three factors, that is, of RP, the plate resistance, of RL, the plate load resistance, and RG, the grid resistance, by the formula:

$$\frac{1}{R_T} = \frac{1}{R_P} + \frac{1}{R_L} + \frac{1}{R_G}$$

For example, assume that a 6J5 tube uses a plate load resistor of 50,000 ohms. The plate resistance of a 6J5 is approximately 7000 ohms. Assume also that the grid resistance of the next stage is 250,000 ohms. The effective resistance of these three in parallel is 5990 ohms. Call this RT for the 6J5 stage. Incidentally, the RP for triodes is low, as shown above. For pentodes, RP will be very high.

The proper value of shunt condenser to connect from plate to ground is one whose capacitive reactance, at 3500 cycles, is equal to RT. Stated again simply, the value in micro-farads is:

$$\frac{1,000,000}{(22,000)(R_T)}$$

This assumes that the high frequency point selected was 3500 cycles. The figure of 22,000 is 3500 times 2 times π . As an example, if RT is 5990 ohms, then the plate to ground condenser calculates out to be 0.0076 mf so use a 0.0075 mf condenser. Connect it to the plate of the tube and to a convenient ground point. Make this calculation for both stages. This takes care of the higher frequency audio tones.

Let us now examine the change we have brought about in the speech amplifier and also examine what we have gained from this change. To do this, we shall have to assume that the response of the speech amplifier, before the change, was fairly uniform from 150 to 6000 cycles. This is the sort of response which might be expected in a speech amplifier following general circuit practice. In addition, the response was probably only five or six db down at 100 and 10,000 cycles.

When you used your speech amplifier, before the change, you were modulating your carrier with all the complex audio tones that existed in the microphone output, over the 100 to 10,000 cycle range. Your sideband power, which is all that the other ham is using to hear your signal, was therefore spread over a wide frequency range. It so happens that it takes a fair amount of modulator power to transmit the lower and higher frequency audio components which are not necessary for intelligibility.

By making the change in your speech amplifier, you now still have the same power in your sidebands, assuming that the percentage of modulation is the same, but you now have a great deal more power available to transmit the range of frequencies that really count, those between 300 and 3500 cycles. Effectively, therefore, you have a "louder" signal, because you have increased power at the audio frequencies to which the other ham listens. In round numbers, the increase in signal strength is about 6 db, which is the same as a four to one increase in carrier power, or the same as putting up an antenna with a 6 db gain over the one you were using.

To get an idea of the response curve which is obtainable, let us look at a speech amplifier which uses, for example, a 6SL7 dual triode for the first two stages, driving a third stage which has a 250,000 ohm grid leak. Assume that the aforementioned changes have been made. Now let us apply a pure tone at 1000 cycles, the midband frequency, and measure the output of the speech amplifier. Next, apply a pure tone of 300 cycles. The output will be down 6 db, or four to one in power. The same thing is true for a 3500 cycle tone. A pure tone at 150 cycles (and at 7000 cycles) will be down 14 db, or twenty-five to one in power.

Thus, while the curve obtained is not of the sharp cutoff variety, it will give essentially the same results, and will certainly sound the same to the ear. Further, it was obtained at practically no cost.

—Lighthouse Larry.

RESTRICTED RANGE SPEECH AMPLIFIER

Audio Amplifier Designed Expressly for Speech Work

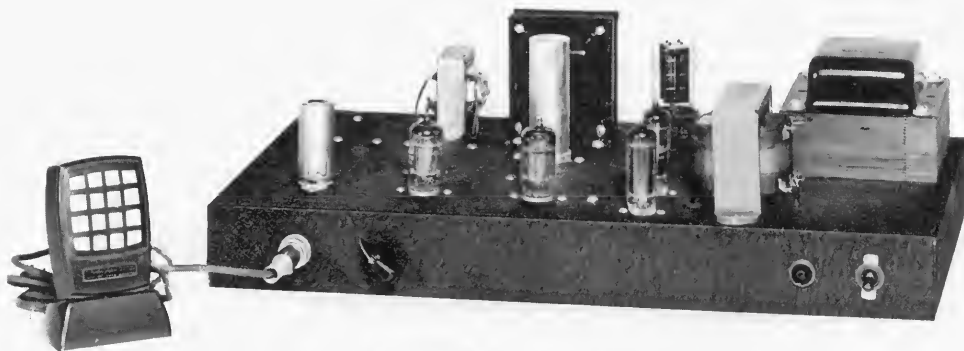

Fig. 1. Front View of the Restricted-range Speech Amplifier

From September-October, 1949

FEATURES—

"Speech" range from 500-2500 cycles

Five miniature tubes—one rectifier

Minimum distortion

Power output of 10 watts

GENERAL CONSIDERATIONS

A speech amplifier for amateur radio service has the job of amplifying the human voice until the complex waveform which forms the human voice has sufficient power to drive the modulator tubes. The amplifier's job, then, is relatively simple. However, the frequency characteristic of the audio amplifier—that is, the amount of amplification which will be obtained at various audio frequencies—determines to a large degree the type of radio-frequency signal which is put on the air.

For example, if you are using a speech amplifier capable of amplifying frequencies beyond ten thousand cycles, and your voice (or extraneous background noise) contains energy at this frequency, then the radio-frequency signal from your transmitter will extend out at least ten thousand cycles—10 kilocycles—on each side of your transmitted radio frequency. Stated another way, your signal has a minimum width of 20 kilocycles. Broad? Quite broad. Even aside from the fact that you have a broad signal, there is little point in transmitting a high fidelity signal. Primarily this is because the average communication receiver does not have an audio system capable of reproducing these high frequencies.

In addition, a highly selective receiver will further restrict the audio frequency characteristic.

If you use another amplifier which has practically no gain at 10,000 cycles, but which drops rapidly in gain past 5000 cycles, then this same voice, using this amplifier, will modulate the radio-frequency carrier so that energy exists out 5 kilocycles each side of the center frequency. This gives a signal with a width of 10 kilocycles. By using this second amplifier, have you lost naturalness, does your voice sound exactly the same to the amateur receiving it over the air as it would if he heard you in person? No. Can you be understood? Yes.

How far can this process be carried? How much can we restrict the bandwidth of the speech amplifier, and still have voice modulation which is adequate for communication purposes? While it is impossible to give an answer to this question which will satisfy everyone, most engineers agree that a bandwidth, for understandable speech, of 500 to 2500 cycles is adequate. This is not as narrow a band as might be imagined. For example, the major radio networks send their programs to their member stations on telephone lines. The best of these lines have a cutoff frequency of approximately 5000 cycles. Certainly

ELECTRICAL CIRCUIT

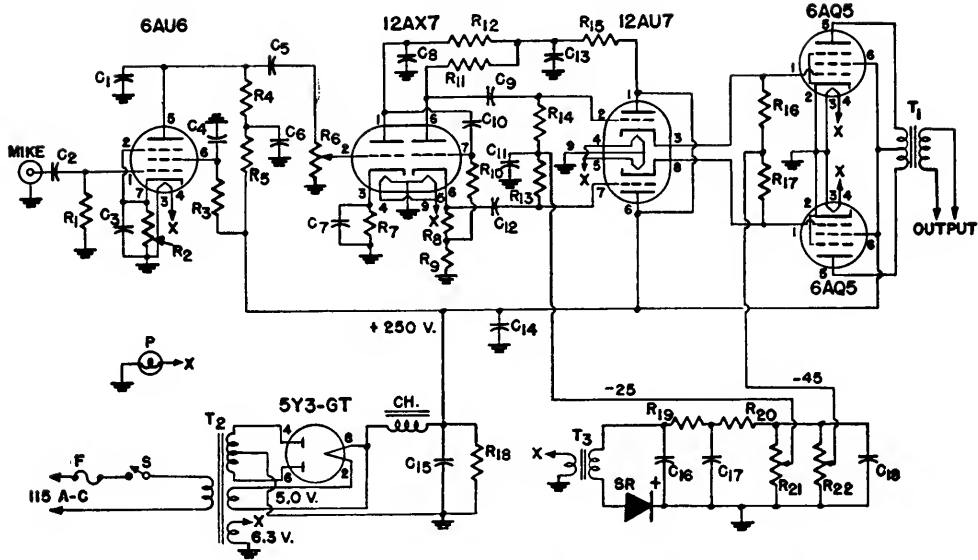

Fig. 2. Circuit Diagram of the Restricted-range Speech Amplifier

CIRCUIT CONSTANTS

C ₁1590 mmf mica (see text)	R ₇3500 ohm, 1 watt
C ₂0.005 mf 600 volt paper	R ₈2500 ohm, ½ watt
C ₃ , C ₇50 mf 50 volt electrolytic	R ₉17,500 ohm, ½ watt
C ₄ , C ₅ , C ₁₃ , C ₁₄8 mf 450 volt electrolytic	R ₁₀0.1 megohm, 1 watt
C ₅1275 mmf mica (see text)	R ₁₁20,000 ohm, 1 watt
C ₈1380 mmf mica (see text)	R ₁₂0.33 megohm, 1 watt
C ₉ , C ₁₂0.01 mf 600 volt paper	R ₁₃ , R ₁₄0.5 megohm, ½ watt
C ₁₀580 mmf mica (see text)	R ₁₅ ...6600 ohm, 6 watt (three 20,000 ohm, 2 watt resistors in parallel)
C ₁₁0.1 mf 600 volt paper	R ₁₆ , R ₁₇6000 ohm, 1 watt
C ₁₅40 mf 450 volt electrolytic	R ₁₈50,000 ohm, 10 watt
C ₁₆ , C ₁₇ , C ₁₈40 mf 150 volt electrolytic	R ₁₉ , R ₂₀1000 ohm, 2 watt
CH.....8 henry smoothing choke, 150 mils	R ₂₁ , R ₂₂10,000 ohm, 10 watt semi-adjustable
F.....2 ampere fuse	S.....SPST toggle switch
P.....6.3 volt pilot light	SR.....Selenium rectifier (G-E 6RS5GH2)
R ₁1 megohm, ½ watt	T ₁Output transformer (see text)
R ₂5500 ohm, 1 watt	T ₂ ...Power transformer, 350-0-350 at 150 mils, 6.3 volts at 4 amperes, 5.0 volts at 3 amperes
R ₃0.47 megohm, 1 watt	T ₃ ...Filament transformer, 6.3 volts at 1 ampere
R ₄47,000 ohm, ½ watt	
R ₅10,000 ohm, 1 watt	
R ₆0.25 megohm potentiometer	

we do not think of network broadcasts as having "poor quality," and yet 5000 cycles (approximately) is the highest audio tone which will be heard when listening to network programs.

The primary advantage in using a speech amplifier which has a restricted high-frequency response is that the radio-frequency signal resulting will occupy less space in the spectrum. Recent FCC amateur proposals which refer to the bandwidth of radio-frequency signals (on which no action has been taken at the time of this writing) can be complied with most easily by sufficient reduction in the response of the speech amplifier at the higher audio frequencies. This is because the radio-frequency bandwidth of a properly operated transmitter is dependent only upon the range of the audio frequencies used to modulate the transmitter. This assumes that the transmitter is free of parasitics, is operating on only one frequency, and the modulation applied is within the modulation

capability of the modulated stage, to cite a few of the effects which may give a broad signal, even though the modulating frequencies are within the proper range.

(However, in the case of NBFM, the use of a restricted-range speech amplifier will not assure that the radio-frequency signal does not occupy too much space. If the frequency swing caused by the modulation is excessive then the radio-frequency signal will be unnecessarily broad.)

Thus far we have discussed primarily the higher-frequency audio tones. However, it is also desirable to eliminate, or attenuate, the low frequency audio response of the speech amplifier. Elimination of all response below, say, 500 cycles, would have no effect on the width of our radio-frequency signal, but it would give us the effect of a stronger signal. It is difficult to put an actual number on the gain which could be achieved, but with relatively simple attenua-

tion means used in the speech amplifier a gain of 5 to 6 decibels would be possible. This is the sort of gain which can be expected from a good two-element parasitically excited beam, or by increasing your power by a factor of four.

The energy output of the male voice is concentrated at the lower frequency end of the audio frequency spectrum. Unfortunately these low frequency components of the male voice contribute little to the intelligence in speech. However, being of high amplitude, a great deal of modulator power and modulation capability is required to transmit them. Obviously we can increase the effective transmitted power by reducing the number of low frequency components in the system. Paradoxically a system with restricted high-frequency response, such as discussed previously, sounds more natural if the low frequency components are attenuated in a balanced manner.

There are many ways to accomplish the desired attenuation of the lower and higher frequency portions of the audio-frequency spectrum. All of these methods use an audio network, either simple or complex, which will attenuate certain frequencies either more or less than other frequencies. The amount of attenuation achieved will depend upon the type of network used.

Referring again to the April 27 FCC proposals no statement has been made public, at the time of this writing, as to the amount of attenuation that the FCC feel is adequate. The attenuation achieved in the amplifier about to be described is shown in Fig. 3. This attenuation averages 12 db per octave. Stated another way, the power is down by a factor of sixteen for each octave considered. For example, the power output of the speech amplifier at 10,000 cycles is one-sixteenth of the power output at 5000 cycles.

Referring again to Fig. 3, the calculated operating range of the speech amplifier is from 500 to 2500 cycles. Note that the curve is not flat over this portion, but that the 500 and 2500 cycle points are approximately 6 db down from the midpoint frequency, which is approximately 1000 cycles. For the first octave below 500 cycles and the first octave above 2500 cycles, the attenuation has not yet reached a slope of 12 db per octave. However, for further octave jumps the attenuation will be quite close to 12 db per octave, so that the 125 and 10,000 cycle points will be down by 26 db and the 62 and 20,000 cycle points down by 38 db.

Note this 62 cycle point. The attenuation at this point is theoretically 38 db or, as actually measured in the speech amplifier, 35 db. This means that the power output at 62 cycles will be only one four-thousandth of the power output at 1000 cycles. This

means that normal precautions regarding sixty cycle hum need not be taken. As a result, the filament wires in this speech amplifier were neither paired and twisted nor carefully handled. One side of each filament connection was grounded and the other lead run as a single wire. While this may not seem startling, those of you who have had trouble with hum in high-gain amplifiers will appreciate this statement.

The design procedure used in this speech amplifier is identical to that discussed in the "Technical Tidbits" section of the July-August, 1949 G-E Ham News. Readers are referred to this article for the background work on the present design. Suffice it to say that C₅ and C₁₀ (see Fig. 2) have the job of attenuating the low frequency end of the audio spectrum, and C₁ and C₈ handle the attenuation of the higher audio frequencies. In other words, the entire job is handled by the proper choice of four condensers, two of which would normally be employed in the amplifier even if a restricted bandwidth were not desired.

ELECTRICAL DETAILS

Referring to the circuit diagram, Fig. 2, the tube functions are as follows. The 6AU6 serves as a pentode voltage amplifier, giving a mid-band gain of well over 100. The first section of the high- μ double-triode 12AX7 serves as the second voltage amplifier, and gives a gain of approximately 50. The second section of the same tube acts as a phase inverter. The 12AU7 tube is a push-pull cathode follower which acts as a low-impedance driving source for the push-pull 6AQ5 output tubes. It is absolutely essential that distortion be held to as low a value as possible if full advantage is made of the restricted bandwidth of this speech amplifier. This is because distortion will cause the radio-frequency signal to become broad, and this is one of the effects that we wished to overcome by restricting the audio bandwidth.

One of the major causes of distortion in the audio systems of amateur transmitters is the use of driver stages with too high an internal impedance to properly drive class AB₁ or Class B stages. Distortion results, in this case, because of poor regulation in the driving voltage when the driver is called upon to supply the grid current drawn during voltage peaks. The 12AU7 cathode follower tube acts as a *low-impedance* driver. This permits more power output from the 6AQ5 tubes with less distortion than would be possible if the 6AQ5 tubes were driven directly from the phase inverter.

Essentially the 6AQ5 tubes are operated as class AB₁ amplifiers. Normally this means that no precautions need be taken with the driver stage to ensure minimum distortion provided that the grids are

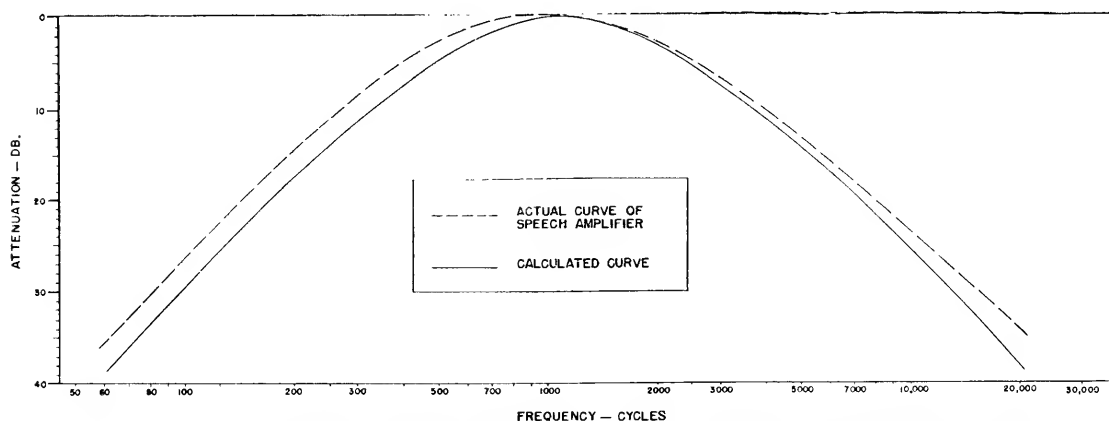

Fig. 3. Theoretical and Actual Frequency Response Curve for the Restricted-range Speech Amplifier

never driven positive. This condition is difficult to achieve unless the average level is kept quite low. By using a driver which presents a low source impedance, which the 12AU7 accomplishes, the average level may be pushed up quite high and the 6AQ5 tubes driven all the way up to the grid bias point. Even if an occasional voice peak causes this voltage point to be exceeded, no distortion will occur due to "folding-up" of the driver stage. The net result is high output, minimum distortion, and a "narrow" radio-frequency signal.

Condensers C_1 , C_5 , C_8 and C_{10} (the frequency controlling condensers) are listed in "Circuit Constants" with values which are not stock values. The values shown are those which calculation indicate to be correct. Try to obtain condensers moderately close to these values. It is not wise to trust the values marked on condensers, and it is recommended that a capacitance bridge be borrowed to check through your stock of mica condensers. It may be easier to parallel condensers in order to get the proper value. For example, C_1 could easily be made up with a 1000 mmf and a 600 mmf condenser in parallel.

One further point might be made, with reference again to the circuit diagram. Fixed bias is supplied to two stages, the 12AU7 stage and the 6AQ5 stage. The bias supply is unusual in one respect. Cathode current for the 12AU7 stage must flow through R_{22} . The total current for both 12AU7 sections is approximately 10 mils. In other words, this bias supply must be capable of supplying a voltage and a current, instead of just a voltage as in the usual case. If the circuit diagram is followed no difficulty will be encountered. However, if you attempt to use another source of bias, make certain that it can supply the required current.

MECHANICAL DETAILS

The amplifier was constructed on a 17 by 10 by 2 inch chassis. However, inasmuch as practically any layout scheme will work, the prospective builder can

use any convenient size chassis and change the layout to suit. The entire speech amplifier and power supply could fit easily in a chassis of half the size of the one just mentioned.

The placement of parts can best be seen in Fig. 1. The tubes are, from left to right, 6AU6, 12AX7, 12AU7, 6AQ5's, and the 5Y3-GT rectifier tube in the rear. Note that the 6AU6 uses a shield. On the rear of the chassis, at the left, is the bias transformer, T_3 , with the choke and C_{15} to the right. The power transformer occupies the rear corner and the output transformer is directly ahead of it.

Only two controls are employed—the on-off switch and the gain control. The microphone input jack and the pilot light are mounted on the front of the chassis, and the fuse on the rear of the chassis.

The underchassis view of the amplifier, Fig. 4, indicates the placement of the remainder of the components. No shielded wire was used, mainly because all leads to the first two stages were short. If the layout is altered from that indicated, it might be advisable to shield any long leads in the first two or three stages.

OPERATING ADJUSTMENTS

Once the amplifier has been completed, and it has been established that voltage can be applied without anything smoking, the 12AU7 bias voltage and cathode-return voltage should be adjusted. R_{21} should be adjusted so that the bias, as read from the arm of R_{21} to ground, is 25 volts. Adjust R_{22} until the voltage from the arm of R_{22} to ground is 45 volts. Next check the bias on the 6AQ5 tubes by reading the voltage from pin 1 of either tube to ground. This voltage should be 15 volts. If this is not true, change the tap on R_{21} slightly until the 6AQ5 bias (pin 1 to ground) reads 15 volts. The 45 volt cathode-return voltage should remain unchanged during this adjustment. It will not be necessary to have any input signal to the speech amplifier during the foregoing tests.

The last check to be made, assuming that the am-

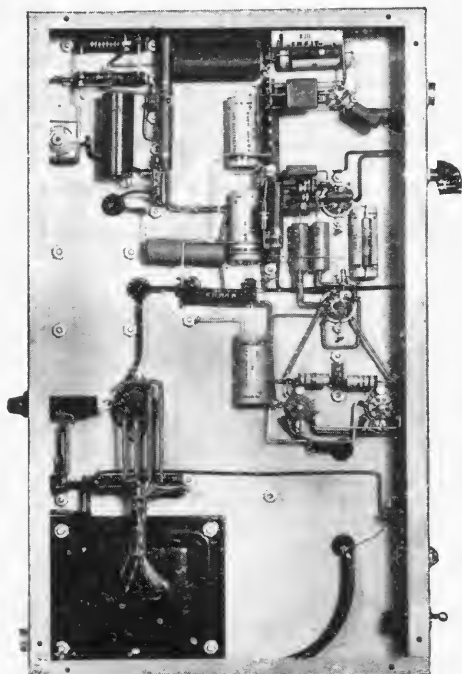

Fig. 4. Under-chassis View of the Restricted-range Speech Amplifier

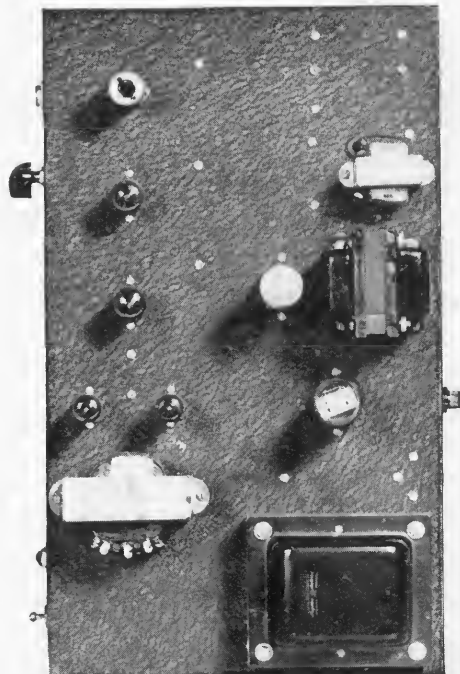

Fig. 5. Top View of the Restricted-range Speech Amplifier

plifier has been correctly wired and is operable, is to match the 6AQ5 tubes to their load. The amount of power that these tubes can deliver will depend to a great degree upon the output transformer. The selection of an output transformer will be governed primarily by the proposed application. It is recommended, however, that a transformer with a number of various impedances be used, so that minor changes in matching may be made.

It is further recommended that a transformer be purchased which has a generous power rating. For example, a 10 watt transformer will serve, but a 20 watt output transformer will permit more output to be achieved without distortion. The amplifier pictured uses a 10 watt output transformer. The highest output power which could be achieved without discernible distortion on an oscilloscope was 7.2 watts (measured output from the transformer). A second amplifier with an 18 watt output transformer permitted an output, under the same conditions, of 11.2 watts. In both cases the transformer was matched to the

output load impedance, which took the form of a resistor.

Therefore, procure a transformer which is capable of matching from an approximate impedance of 10,000 ohms (the plate-to-plate effective load resistance of the 6AQ5 tubes) to whatever class B grids you wish to drive. Or, you may wish to match 10,000 ohms to a 500 ohm line. In the latter case another transformer is required to match from the 500 ohm line to the modulator grids. If this system is used, approximately twice as much power is lost between the driver plates and the modulator grids as compared to the case where only one transformer is used. You may expect to get losses up to 3 db in each transformer. Three db is two-to-one in power.

Once the transformer is procured and the amplifier tested while driving the required load, it may be advisable to make small changes in the impedance ratio between driver and modulator to ensure that you have an impedance match which will give maximum power transfer with minimum distortion.

LOGARITHMIC COMPRESSOR

Aids in Preventing Overmodulation While Increasing Signal Effectiveness

From May-June, 1950



Fig. 1. The Logarithmic Compressor ready to plug into your present microphone jack. Controls are, left to right, in-out switch, compression control, output control and a-c on-off switch.

FEATURES—

Provides 10 db increased effectiveness

Uses self-contained speech-range filter

Three tubes, including rectifier

Small size—space saving

**TRANSFER CHARACTERISTIC OF BACK-TO-BACK
COPPER OXIDE INSTRUMENT RECTIFIER**

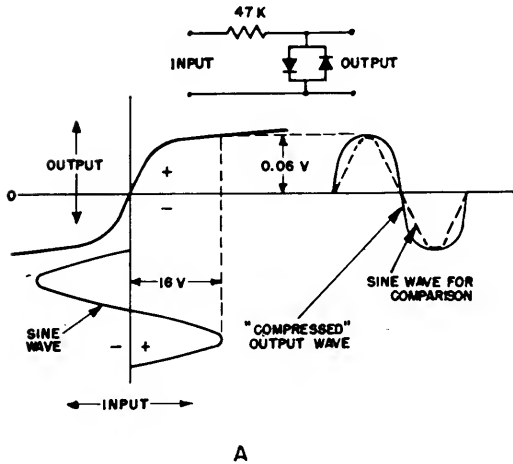

**TRANSFER CHARACTERISTIC OF
USUAL DIODE CLIPPER CIRCUIT**

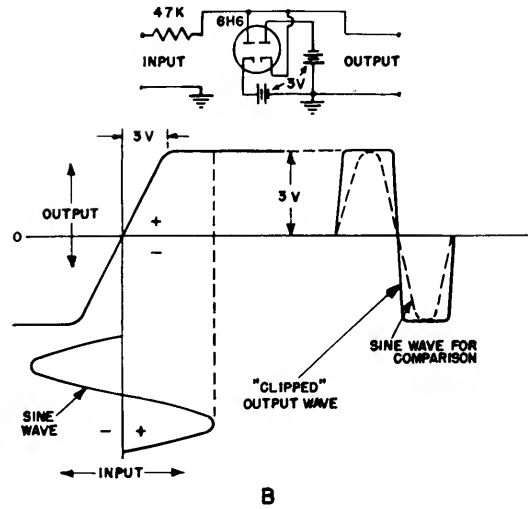

Fig. 2. A comparison between the output waveform of a Logarithmic Compressor and a diode clipper.

Every phone man, at some time in his QRM-ridden life, has wished that he had a small switch available which would permit him magically to increase his power tenfold. This would be Utopia—from one kilowatt to ten kilowatts by pressing a button.

This button is now available, and it is mounted on the front of the Logarithmic Compressor. This unit will give an effective signal gain which is adjustable from a few db up to as much as ten db (ten to one in power).

The Logarithmic Compressor is an audio amplifier device which is inserted between your microphone and your present speech amplifier. Its function is to push up the average modulation level, with the result that high percentage modulation is assured at all times, regardless of the sound level reaching the microphone.

COMPRESSION VS. CLIPPING

Those familiar with clippers or clipping circuits can see that the Logarithmic Compressor is intended to do the same sort of job as a clipper. There is, however, an important difference between logarithmic compression as used in the Logarithmic Compressor and clipping.

Fig. 2 compares the characteristics of the two different systems. In either case the input wave suffers distortion, but the distortion caused by the clipping action of the ordinary diode type clipper (Fig. 2B) is worse for a given amount of signal compression than that caused by the logarithmic compression of a copper-oxide instrument rectifier (Fig. 2A).

Distortion present in either circuit will add "harshness" to speech signals and without further treatment would result in excessively broad signals. Therefore, any distorting type circuit should be followed by a suitable filter to prevent the high frequency products produced by this distortion from reaching the modulated stage. With such a filter much of the "harshness" will still be present but the radio-frequency signal need not be broad. The harshness results from cross modulation (distortion) products that lie within the pass band of the filter.

The advantage of the logarithmic compression system is that the distortion is less severe (for a given amount of compression) than the clipper type, and this makes possible the use of a vastly simpler filter arrangement. Three "stages" of R-C type filtering used in the Logarithmic Compressor are as effective as more elaborate sharp-cutoff types of L-C filter virtually necessary with the clipper type of circuit.

Further, the transient response of the R-C type filter is such that no overshoot of signal peaks can occur. This is not the case with sharp-cutoff L-C filters. This means that the logarithmic compressor circuit with a properly designed R-C filter is superior to the ordinary clipper circuit followed by a sharp L-C filter. Repeated tests confirm this statement.

CIRCUIT DETAILS

With reference to Fig. 3 it will be seen that the first 12AT7 acts as a two stage audio amplifier to bring the signal from the microphone to a sufficient level so that the compression circuit itself operates at the proper level. Resistor R_1 in the first stage has been added as a precaution against radio-frequency feedback.

Special care has been taken to attenuate low audio frequencies prior to compression. Doing this gives a well balanced speech response as well as minimizing much of the distortion caused by cross-modulation between the low speech frequencies and the *intelligence-bearing* high speech frequencies. The values of condensers C_2 , C_3 and C_4 are chosen to attenuate the low frequencies adequately before speech compression. Condensers C_7 and C_9 serve the same purpose after compression has taken place.

Resistor R_4 , by varying the signal input to the second section of the first 12AT7, enables control of the amount of compression.

The audio transformer, T_1 , is necessary because the limiting circuit must be fed by a low-impedance, low-resistance source. Using the center-tap on this transformer accomplishes this function.

The actual limiting or compression circuit consists

ELECTRICAL CIRCUIT

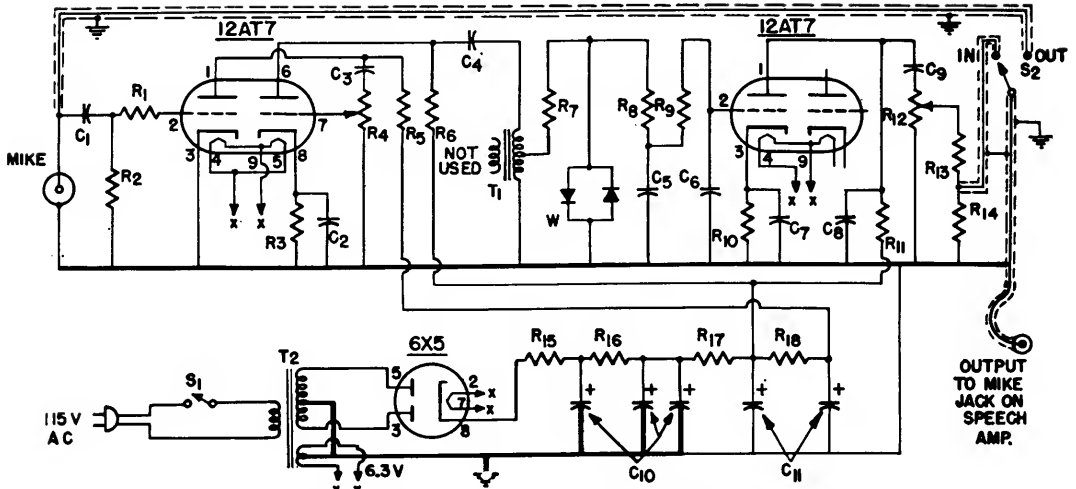

Fig. 3. Circuit diagram of the Logarithmic Compressor.

CIRCUIT CONSTANTS

(All resistors and capacitors = 20% tolerance unless specified otherwise)

C_1, C_9	0.01 mf 400 volt paper or mica	R_9	0.56 megohm, = 10%, 1/2 watt
C_2, C_7	1.0 mf paper (see text)	R_{12}	0.1 megohm potentiometer
C_3	1000 mmf mica	R_{13}	0.47 megohm, 1/2 watt
C_4	0.05 mf 400 volt paper	R_{15}470 ohm, 2 watt
C_5	1000 mmf = 10% mica	R_{16}2200 ohm, 2 watt
C_6	100 mmf = 10% mica	R_{17}	1000 ohm, 1 watt
C_8	0.005 mf = 10% mica	R_{18}	4700 ohm, 1 watt
C_{10}	15-15-15 mf 450 volt electrolytic (see text)	S_1	SPST toggle switch
C_{11}	10-10 mf 450 volt electrolytic	S_2	SPDT toggle switch
R_1, R_{14}	10,000 ohm, 1/2 watt	T_1	Push-pull plates to voice coil audio transformer, UTC R-38A (see text)
R_2	10 megohm, 1/2 watt	T_2	Power transformer, 300-0-300 volts at 50 mils, 6.3 volts at 2 amperes UTC R-54
R_3, R_{10}470 ohm, 1/2 watt	W	Copper-oxide instrument rectifier (see text)
R_4	0.5 megohm potentiometer		
R_5	0.1 megohm, 1 watt		
R_6, R_{11}	47,000 ohm, 1 watt		
R_7	47,000 ohm, 1/2 watt		
R_8	56,000 ohm, = 10%, 1/2 watt		

only of R_7 and W , the latter being two sections of a copper-oxide instrument rectifier. Resistors R_8 and R_9 , together with condensers C_5 and C_6 , act as a two-section R-C filter. The output of this filter feeds the second 12AT7 directly. Resistor R_{12} acts as an output control so that the output level from the speech compressor may be made to match the output level of the microphone. Thus when the speech compressor is switched out of the circuit no other adjustment need be made.

The output tube is required for two reasons. It is necessary to present the proper load to the two R-C filters and, secondly, to permit a third R-C stage to be utilized. Inasmuch as the second section of the 12AT7 tube is not used this may seem like wasting part of the tube, but the use of a high- μ triode was dictated and the 12AT7 fills this requirement nicely. Note that the heater of the unused section need not be energized. Many uses for this extra tube section will undoubtedly suggest themselves.

The in-out switch, S_2 , allows the unit to be switched in and out of the circuit easily. Note that shielded wire is specified for the connections to this switch. The output itself is carried by a shielded lead which

plugs into the mike jack of any speech amplifier designed to handle a high impedance dynamic or crystal microphone.

The power supply is conventional in all respects. Because of the low current drain on the power supply a resistor-capacitor filter is employed. Resistor R_{18} and condenser C_{11} provide decoupling and additional filtering for the first 12AT7 section plate voltage.

The connections indicated by the heavy black lines in the power supply section should all be made to one ground point. This will prevent the chassis from carrying the circulating capacitor current and help to keep the unit hum-free.

CONSTRUCTIONAL DETAILS

As may be seen from the photographs, the entire unit, including power supply, is mounted on a 5 by 7 by 2 inch chassis. While the layout is not critical, it is advisable to keep the power supply portion of the circuit as far away from the rest of the circuit as possible. The layout shown is quite satisfactory.

With reference to Fig. 1, the front panel layout, from left to right, is: mike jack, output lead, in-out

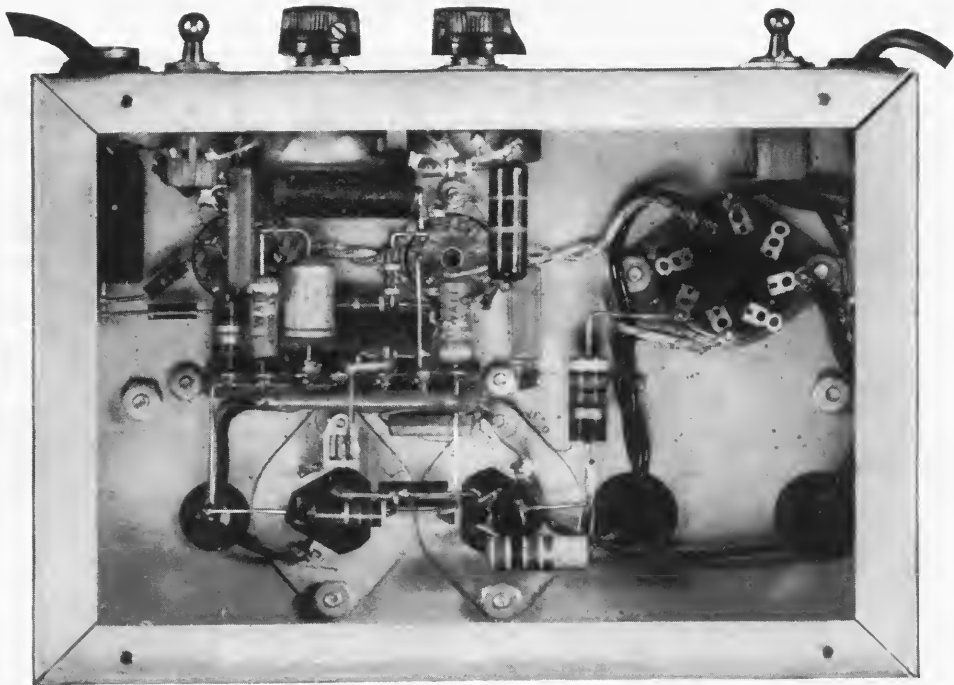

Fig. 4. Under-chassis view of the Logarithmic Compressor. There is ample room for all component parts.

switch, compression control, output level control, a-c on-off switch and a-c cord. The tubes are, left to right, input 12AT7, output 12AT7 and 6X5 rectifier. Note that the two 12AT7 tubes are shielded.

Fig. 4 gives the details of the wiring. Nothing here is critical if normal wiring procedure is followed. Note that R_1 is placed as close to the grid pin as possible.

The wiring can be made simpler if the unused leads from the power transformer are pulled inside the transformer case and securely taped to avoid shorts. This was done with the 2.5 volt and the 5.0 volt windings.

The unit pictured uses a bottom cover plate for the chassis. This is recommended to avoid r-f feedback. Any sort of thin metal will serve for this purpose, if your chassis comes without a bottom plate.

COMPONENT PARTS

While no extremely critical values are required, it is recommended that the specified values be used in all cases. For example, C_2 and C_7 are specified as 1.0 mf condensers. If lower values were to be used, the frequency response would suffer, and if higher values were used, the result would be insufficient low-frequency attenuation.

Condenser C_{10} is about the only component which could be changed. Here a 20-20 mf condenser could be used, with one of the 20 mf section on either side of R_{16} .

Almost any sort of push-pull plates to voice coil transformer will serve as T_1 . Wattage rating of this transformer is not important.

If possible, linear taper potentiometers should be used at R_4 and R_{12} . This sort of taper will give a smoother action than other types of taper.

Care must be taken in purchasing the limiter rectifier, W , because instrument rectifiers come in several different styles. Basically, of course, they are

used to make a-c meters out of d-c meters. However, they can be purchased as half-wave units, doubler units, full-wave units and bridge units.

Two separate half-wave units, connected as shown, will work, and the bridge-rectifier style will work if the proper leads are used. The "full-wave" unit will not serve because the two diode sections are connected improperly. In the doubler type rectifier the two diode units are connected as shown in Figs. 2 and 3 and therefore this type of instrument rectifier would be the best to use.

COMPRESSION ADJUSTMENT

The adjustment of the Logarithmic Compressor is done very easily. Plug in a mike and place the in-out switch, S_2 , in the "out" position so that the microphone is connected directly to your speech amplifier, then follow these three steps:

1. Adjust the audio gain control on the transmitter for normal modulation as seen on an oscilloscope (the best method) or some other instrument worthy of trust.

2. Put the output control on the unit to zero and set the compression control so that it is about half open. Switch the compressor to "in" and advance the output control while speaking into the microphone until the *peak* modulation is the same as in step 1. While an oscilloscope is not absolutely necessary in order to make this adjustment, it is strongly recommended.

3. Adjust the compression control so that the average plate current in the modulator stage on a sustained "00000—0" is, say, not over twice that obtained with the compressor out. Then try compressor "in" and "out" on a few QSO's to find the best operating point of the compression control for the microphone you are using and the receiving conditions prevalent at the other fellow's QTH.



Fig. 5. Top view of the Logarithmic Compressor. The audio section is on the right and the power supply section is on the left.

USE OF THE COMPRESSOR

With the Logarithmic Compressor in use the modulator tubes are required to handle much more average power than usual. In fact, it is possible that your modulator stage will not be capable of handling the extra average power required. Careful checking with an oscilloscope will determine if this is the case.

As a general rule, if your modulator can handle a sine wave signal at 100% modulation, then the average power capability of your modulator is adequate for use with the Logarithmic Compressor. (After all, this ten db gain has to come from some place!) This means that, for a kilowatt rig, your modulator should be capable of continuous operation at 500 watts output at 1000 cycles. For lower powers the same ratio holds.

In operation the compressor must be used with judgment—good judgment that is. Too much compression may make an otherwise acceptable signal almost intolerable. With a judicious amount of compression one can expect to add from 6 db (4 to 1 in power) to 10 db (10 to 1 in power) in the effectiveness of his signal *provided* conditions at the receiving point are such that understandability without the compressor is impaired by QRM or high background noise.

RESULTS WITH THE COMPRESSOR

In many months of test at W2KUJ the following information has been obtained. Nearby stations, or stations not experiencing QRM, prefer that the compressor *not* be used. Stations receiving a weak signal or listening through severe QRM prefer that the compressor *be* used.

Reports from the latter stations range from eight to ten db jump in effective signal strength when the

compressor is switched in. Reports from nearby stations are that the signal is *louder*, but somewhat less readable with the compressor in use than without it.

In no case has a report been given that the signal was broader when the compressor was used, even when this question was asked of nearby stations.

Tests made at W2RYT's shack indicate that different microphones give somewhat different results when used with the compressor. For example, an Electro-Voice Model 605 dynamic mike (pictured in Fig. 1) and an Electro-Voice Model 915 crystal mike seemed to have identical speech characteristics (although the dynamic mike had less output) when used without the compressor.

When used with the compressor, the dynamic mike was found to have a speech quality which was less harsh than that of the crystal mike. Further, it was found advisable to advance the compression control with the dynamic mike.

The foregoing is not intended as a recommendation for dynamic mikes, nor is it intended as an authoritative comparison between two Electro-Voice microphones. The comparison has been made to emphasize the importance of testing your compressor carefully with each microphone you may use with it.

In summary, one can expect to boost the effectiveness of his signal when it is needed most by use of the compressor (it frequently means the difference between making a contact or not) with some decrease in ease of reading the signal where the compressor is not needed.

Bear in mind that the compressor *can be* misused (to your disadvantage). Seek honestly to find the operating points which best exploit its use. In many cases it is best to *not* use the compressor. But in those cases where it is needed, the Logarithmic Compressor can really do a job for you.

Added Information for Logarithmic Compressor

The comments below answer many of the questions regarding the copper oxide rectifiers and other components in this unit, plus applying the circuit to existing audio equipment for single sideband and other amateur transmitters.

1. COMPONENTS PARTS - RECTIFIERS - Suitable copper oxide instrument rectifiers (W in schematic diagram) are made by several manufacturers. The following list includes rectifiers shown in the catalogs of several mail order electronic components suppliers (Allied Radio, Radio Shack, etc.):

Schauer Mfg. Corp. 1- doubler type A2MC,
4513 Alpine Ave. or,
Cincinnati, Ohio 2- half wave types A1P

Conant Laboratories 1- doubler type 160-
6500 "Q" st. BHS, or
Lincoln, Nebraska 2-half wave types 160B

Bradley Laboratories 1- doubler type CX2E
168 Columbus Ave. series, or
New Haven 11, Conn. 2- half wave types
CX2E series

2. COMPONENT PARTS - TRANSFORMER T_1 -- A UTC type R-38A universal output transformer (push-pull plates to voice coil) was recommended for this circuit. Any similar transformer made by other firms may be used instead. Similar transformers are: Stancor A-3856, Thordarson 24S60, Merit A-3936 or A2938, Halldorson Z1404, Triad S-15X, and Freed RGA-11. Certain center-tapped audio chokes may be used, if available. Try the choke you happen to have and check the operation of the compressor with an oscilloscope. A waveform similar to that shown in Fig. 2A in the May-June, 1950 issue should be obtained for best results.

3. SUBSTITUTING TUBE CATHODE FOLLOWER FOR T_1 -- Although some experimenters have reported moderate success with a cathode follower tube instead of T_1 (the unused half of one 12AT7 in the original circuit), best results will be obtained with the original circuit components. These parts

and values were determined by many hours of laboratory tests. The transformer, T_1 , provides a low-resistance path for the non-linear signal applied to the rectifiers. A positive bias (from the current flow through the cathode resistor) will be applied to the copper oxide rectifiers when they are driven from a cathode follower, unless a large coupling capacitor (about 20 mfd.) is placed between the tube cathode and the rectifiers.

4. SUBSTITUTING OTHER RECTIFIERS FOR "W" -- Tests have indicated that germanium, selenium and silicon rectifiers exhibit the same logarithmic characteristic as copper oxide rectifiers, but to a lesser extent. Thus, they will not perform as efficiently in this circuit over such a wide compression range (about 40 db with the copper oxide rectifiers).

5. INCORPORATING COMPRESSOR INTO EXISTING AUDIO GEAR -- The basic compressor circuit -- C_4 , C_5 , R_7 , R_8 , R_9 , T_1 and W -- may be connected into an existing speech amplifier circuit. However, the frequency response of the stages preceding the compressor should be tailored to attenuate frequencies below 300 cycles. Also, extra components (low-pass RC filter formed by R_8 , R_9 , C_5 , C_6 , C_7 , C_8 , etc.) should be added to the following stages to attenuate any harmonics generated in the compressor circuit.

6. LOGARITHMIC COMPRESSOR ON SSB TRANSMITTERS -- Several radio amateurs with filter-type SSB transmitters have reported that this type of compressor can be used successfully. Audio harmonics generated in the usual type of clipper can cause severe ringing in the sideband filter circuits, with disastrous effects on signal quality. Check the amount of compression with an oscilloscope so that the SSB exciter and linear amplifiers are not overloaded, since adding the compressor will increase the average power input of a linear SSB transmitter from TWO to TEN times.

HIGH ATTENUATION LOW-PASS AUDIO FILTER

From March-April, 1955



This audio filter for receiver or speech amplifier uses inexpensive unshielded coils plus a few of W2KUJ's slick tricks to obtain an attenuation slope approaching that possible with high-priced toroid coils.

—*Lighthouse Larry*

LOW-PASS AUDIO FILTER

A sharp cut-off low-pass filter is a great help in eliminating the annoyance of heterodynes and noise beyond the range necessary for completely satisfactory phone reception. The filter described here is an inexpensive and highly effective weapon in the fight against QRM. Used in the speech system of a transmitter, this filter reduces the spectrum space occupied by the signal, while actually increasing the effectiveness of the transmission. It is connected as shown in Fig. 1.

Because the filter is intended for a variety of applications, a vacuum tube is employed to provide high input and low output impedance. Thus, all the requirements of impedance matching for the passive elements of the filter are satisfied internally and are not disturbed when the filter is interposed between a wide variety of devices.

The design cut-off frequency of the filter pictured on the cover of this issue of G-E HAM NEWS is 3000 CPS, a figure generally considered adequate for voice communication. Design data is given for the prototype low-pass filter in "Thumbnail Theory" for those who want to design their filter for a different cut-off frequency. It is suggested that the 3000 CPS cut-off design be used unless it is certain that a different cut-off point is required for some specific application.

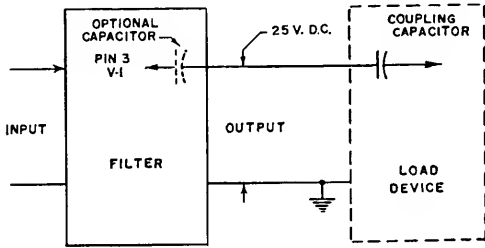

Fig. 1 Diagram for connecting the low-pass filter to the input and load devices.

CONSTRUCTION

The entire filter is housed in a 3 x 4 x 5-inch utility box drilled as shown in Fig. 2. The tube socket, input and output jacks are mounted on one cover. Although

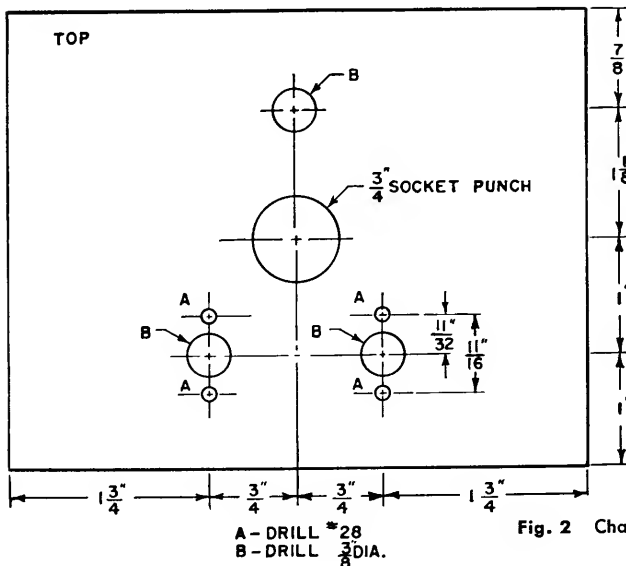

Fig. 2 Chassis drilling layout.

the filter elements are not in "cramped" space, a certain amount of clearance is required between coils in different filter sections. The circuit diagram and parts list are shown on page 5.

The six 125-mh coils are mounted on the aluminum brackets shown in Fig. 3 with 6-32 brass machine

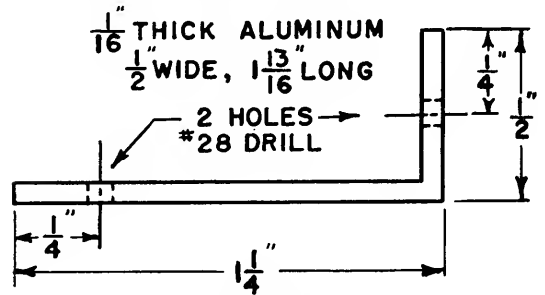

Fig. 3 Mounting brackets for the coils.

screws 1 inch long which pass through the centers of the coils. The brackets are then fastened to the 3 x 4-inch ends of the box, as pictured in Fig. 4. Note how L_1 and L_6 are mounted with respect to the other coils. All the wiring between the coils, condensers C_1, C_2, C_3 and the 2400-ohm terminating resistor is done with the covers removed. Attach 4-inch leads to the input end of L_1 and the output end of L_6 for later connection to the tube socket.

The brackets holding L_1 and L_6 should not be securely tightened until after performance tests are completed. Do not rely on the steel box to provide the ground path indicated in the circuit diagram. Instead, run a lead to the grounded ends of C_1, C_2 and R_4 , and bring this lead out to the ground points on the top cover. Heater and plate power are supplied through a four-conductor cable anchored to the cover.

TESTS

After a wiring check, heater and plate voltage can be applied. Approximately 25 volts DC should appear across the output resistor. If the correct values of inductors and capacitors have been used, the performance

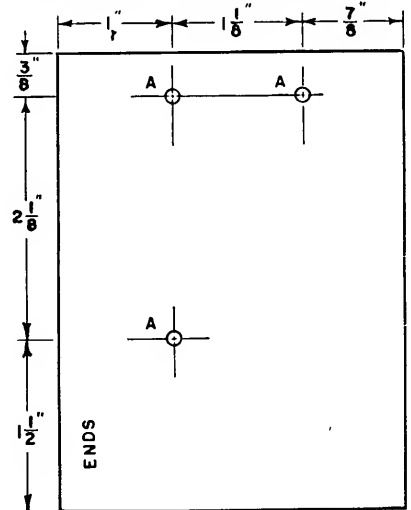

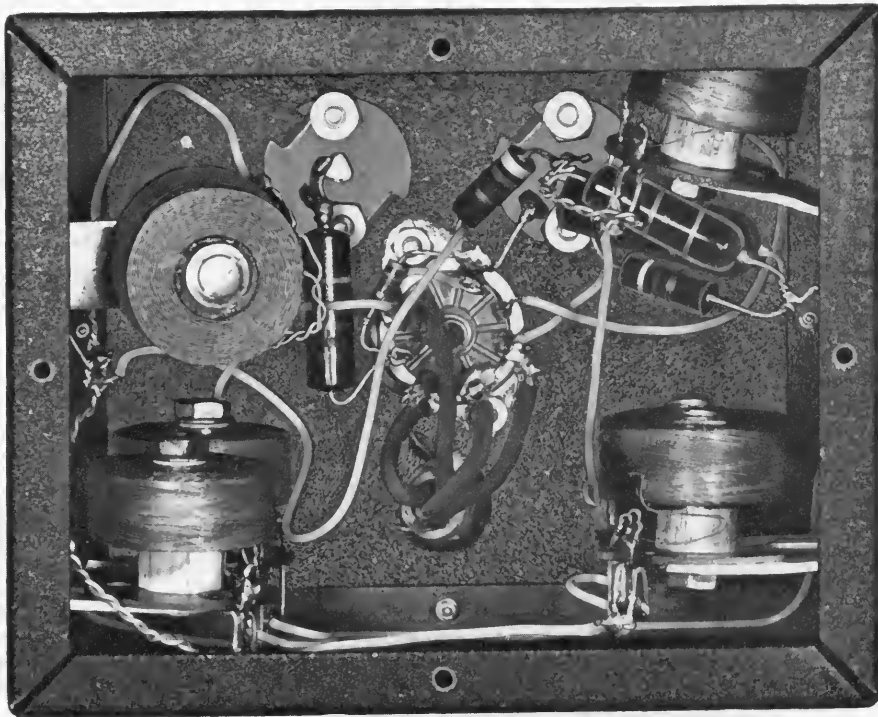

Fig. 4 Bottom view of filter showing socket placed with pins 1 and 9 toward phono jacks. Solder lugs under coil bracket mounting screws are used as ground tie-points for C_1 , C_2 and C_3 .

will be that shown by the curve "A" of Fig. 6, at least to an attenuation of 30 db without any further work on your part. Usually an improvement in attenuation at frequencies higher than 4000 CPS can be made by orientation of L_1 and L_6 , if suitable measuring equipment is available. Tests made by ear alone are not sufficiently reliable to warrant the effort. A reliably calibrated audio oscillator covering a range from 100 to 10,000 CPS at an output voltage of about 10 volts RMS, and an output indicator covering a range of at least 60 db (1000 to 1 in voltage) are required.

In case orientation of L_1 and L_6 through a few degrees does not allow an attenuation of 60 db or more to be obtained at 6000 CPS, reversal of connections to either L_1 or L_6 (but not both) should allow the performance shown in curve "B" to be equalled or surpassed in the region of high attenuation. The final adjustment of the filter model shown in the illustrations was obtained by setting the test frequency at 7000 CPS and bending the brackets holding L_1 and L_6 for minimum output. Tests with an oscilloscope revealed that the minimum was really a null at 7000 CPS and that the measured output 85 db below the reference level was hum and noise. Beyond 7000 CPS the output rose to about 70 db below reference level and dropped slowly above 10,000 CPS. The insertion loss of this filter is 7 db; that is, the output voltage at 100 CPS is 7 db less than the input voltage. This loss is a consequence mainly of the resistance of the choke coils used.

APPLICATION

The maximum operating level for the filter is 10 volts RMS at the input. Operation at higher levels will introduce distortion due to overloading of the input triode. Practical operating levels will range between 1 and 10 volts. Operation at lower levels will, of course, degrade the signal-to-hum ratio. It will be

observed that the hum level in the output is determined by the amount of stray magnetic field in the vicinity of the filter since the coils are not magnetically shielded. A power supply is not included as part of the filter for this reason. Ordinarily, the small amount of heater and plate power required can be borrowed from other apparatus with which the unit is used. If excessive hum is experienced, try moving the filter to a more favorable position, or orienting it for minimum hum pickup.

As a receiving accessory, the filter is inserted in an audio circuit where the operating levels are within range. In most receivers, the output of the first audio stage will provide a suitable signal level for the filter input. When used with the Signal Slicer (G-E HAM NEWS, Volume 6, No. 4) the filter should be inserted between the slicer output and its succeeding audio amplifier. Note that the 4700-ohm output resistor should not be short-circuited by the device into which the filter operates. A coupling capacitor with reactance equal to one-tenth the input impedance of the load at the lowest desired frequency should be provided at the input to any such load (see Fig. 1). Such a capacitor can be incorporated as part of the filter unit to avoid mistakes.

Whether the crystal filter in the receiver is used or not, this filter will improve CW reception somewhat even though the bandwidth is greater than needed for that application. The improvement obtained will depend on the characteristics of the receiver and the particular QRM problem encountered.

For use as a bandwidth control in transmission, the filter is inserted in the audio circuits at a point where the operating levels are suitable. The above precautions regarding the load circuit should be observed. When

Fig. 5 Schematic diagram

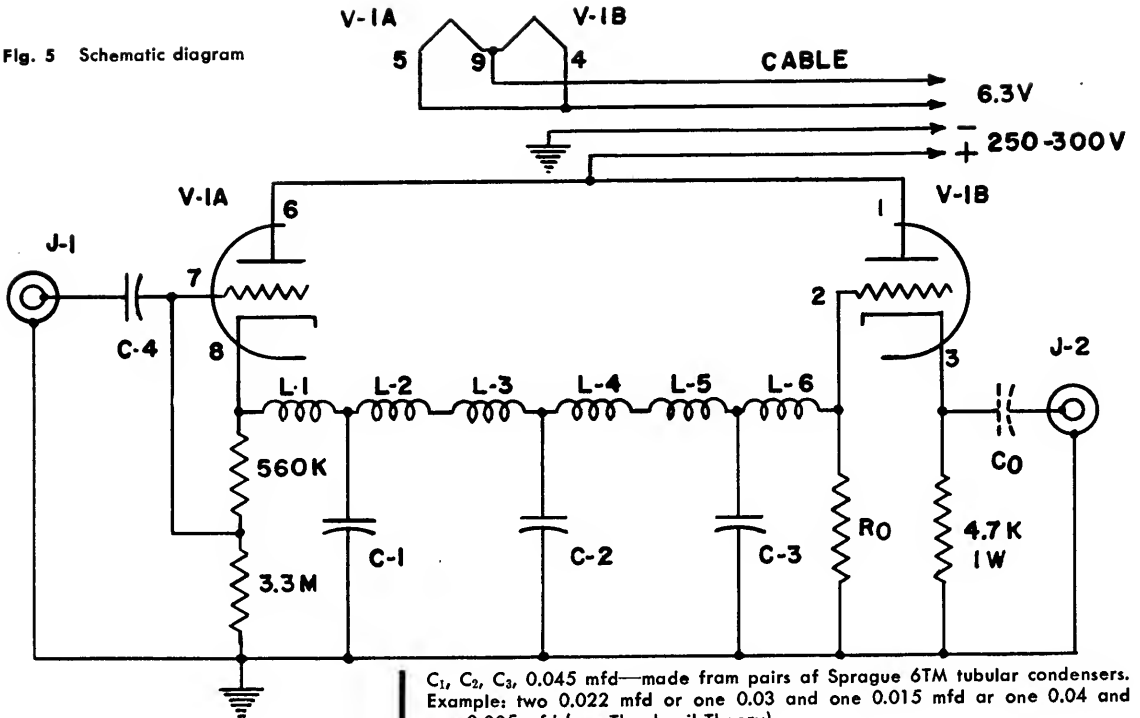

PARTS LIST

- C₁, C₂, C₃, 0.045 mfd—made from pairs of Sprague 6TM tubular condensers. Example: two 0.022 mfd or one 0.03 and one 0.015 mfd or one 0.04 and one 0.005 mfd (see Thumbnail Theory).
 - C₄—0.01 mfd, 600 volts.
 - C₀—Capacity dependent on load impedance, see text (Application).
 - J₁, J₂—Cinch shielded phano jacks.
 - L₁—L₆—125 mh RF chokes (Meissner 19-6848).
 - R₀—2400 ohms, 1 watt ±5%.
 - V₁—12AT7 tube.
- All resistance values in ohms, ½ watt ±20% except as nated. K=1000.

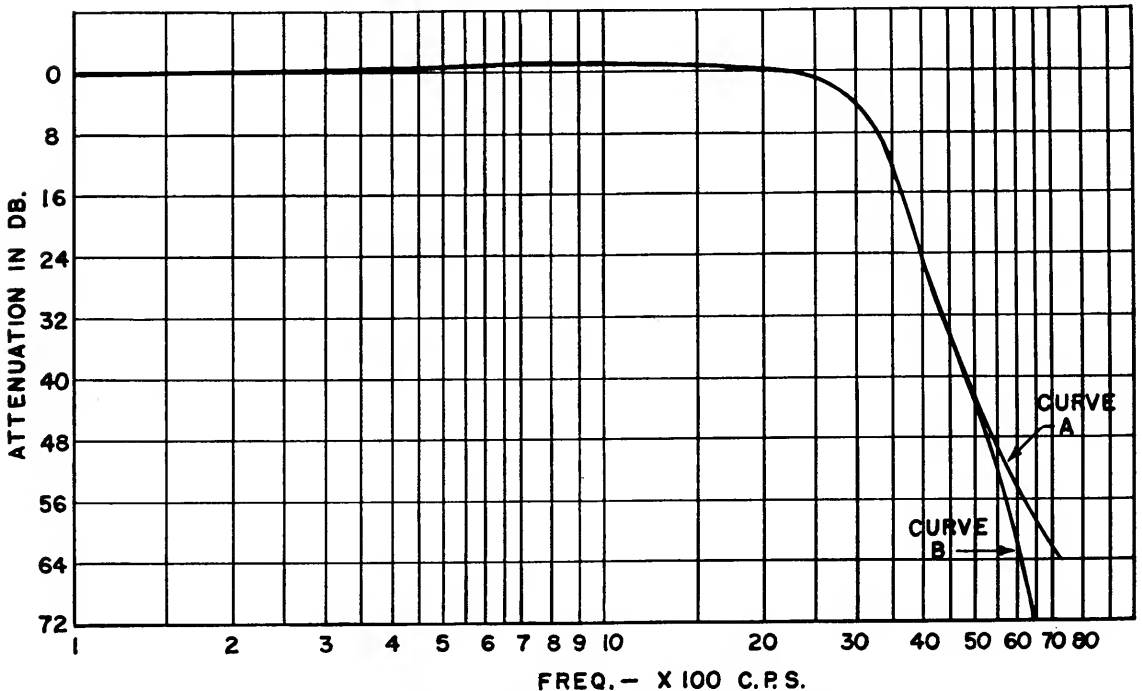

Fig. 6 Responce curves with and without calls oriented.

used in conjunction with the SSB Jr. exciter (G-E HAM NEWS, Volume 5, No. 6) the filter output can connect directly to the audio input jack of the exciter if an 0.01 mfd coupling condenser is inserted in either the filter output or exciter input.

The filter characteristics do not provide for attenuation of low frequencies. Where it is desired to tailor the audio response of the transmitter, this may be done in the circuits either preceding or following the filter. When low-frequency attenuation is introduced after the filter, hum pickup in the filter itself will be attenuated. (See G-E HAM NEWS, Volume 4, No. 4, for simple means of introducing low-frequency attenuation in speech amplifier circuits.)

The "dyed-in-the-wool" experimenter will find many other applications for a handy sharp cut-off filter such as the one described here. Even though the filter is normally used in only one place (say as part of the receiver setup) it will be found convenient to provide input and output jacks so that the device may be patched into other apparatus as the need occurs. In this way a single filter can be made to serve a variety of uses.

THUMBNAIL THEORY

The design of filters can not be covered very thoroughly in a few paragraphs. For those who want some background information on filters the following will be of interest.

The basic filter section used in the device described in this issue is called the "constant K prototype," shown in Fig. 7. Any number of these sections may be joined together for greater attenuation beyond the cut-off frequency. When this is done, the internal sections can be considered as either π or T sections. A multiple section filter is called a "composite" filter. In the ideal case, a constant K filter must be driven by a source having an internal impedance equal to the characteristic impedance of the filter section and

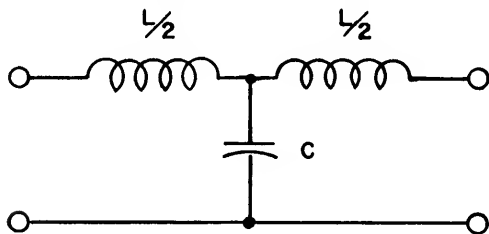
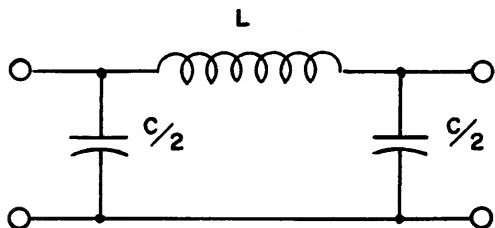

Fig. 7 Above is a T structure filter section. When several T's or π 's are joined in a complete filter, the internal sections lose their identity.

Fig. 8 Below is a π structure filter section.



the filter must be terminated by the same impedance. Ideally, too, the filter elements should be perfect reactances. Practically speaking, the characteristic impedance varies throughout the pass-band of the

filter. Of course, the filter elements do have loss (they are not perfect reactances) so that other considerations enter into the design of filters. Even when perfect filter elements are assumed, the variation of characteristic impedance within the pass-band presents a problem that is solved partially by more complex circuit arrangements known as "M-derived" filters.

In filter design, as in most things, a compromise must be made between performance and complexity, or cost. In our case, certain liberties were taken with classical filter theory to provide acceptably good performance with basically straightforward and simple circuits. A low source impedance is provided by the cathode follower input arrangement shown in the schematic diagram, while the terminating impedance is a resistor of a constant value. These departures cause minor variations of the attenuation within the pass-band. Fortunately, these variations are partially smoothed out by the loss in the filter coils and the approach to ideal operation is thereby improved. Non-ideal filter elements can be used with considerable saving in cost and a less complex filter arrangement can be built. The loss in the coils accounts for the bulk of the "insertion loss" mentioned earlier. About 2 db of the insertion loss is accounted for by the two tube sections used.

The composite filter in this article comprises three identical T sections joined together. Since a low driving impedance is used, no advantage could be achieved by a π structure. Rather than select a certain characteristic impedance and then prune commercial coils to necessary values in order to provide the desired cut-off frequency, the design equation for inductance *per section* was solved for R_0 , the low-frequency characteristic impedance. Thus:

(1) $R_0 = \pi f_c L$, where f_c is the cut-off frequency and L is twice the inductance value obtainable. When $f_c = 3000$ CPS, then $L = 0.25$ henry.

(2) $R_0 = \pi \times 3000 \times 0.25 = 2360$ ohms. Keeping f_c at 3000 CPS, and using $R_0 = 2360$ ohms

$$(3) C = \frac{1}{\pi f_c R_0} = \frac{1}{\pi \times 3000 \times 2360} = 0.000000045 \text{ farads.}$$

Thus $C = 0.045$ microfarads.

Equations (1) and (3) can be used in designing low-pass filter sections for other cut-off frequencies if desired. A filter is said to "cut-off" when its attenuation reaches 3 db.

The coils used in the sample filter had an inductance value of 0.125 henry each. The measured Q at 1000 CPS was 2.20. The total value of 0.25 henry required per section is twice the value of the individual coils obtainable. The filter capacitors were made up of two selected commercial plastic-encased paper capacitors connected in parallel to provide the calculated value of 0.045 ufd. The individual capacitors were checked for value and paired for as nearly matched composite values as possible, as well as adherence to the design value required.

The sharpness of cut-off obtained with this filter is greater than that indicated by classical filter theory when constant resistive source and load impedances of the value R_0 are used. This greater attenuation is paid for by the irregularities shown between 1000 and 2500 CPS, a really small price indeed. The additional attenuation obtained beyond the 40 db point by coupling between L_1 and L_6 to provide "infinite" attenuation at 7000 CPS serves to increase the slope of the characteristic between 4000 and 7000 CPS at the expense of smaller attenuation beyond about 10,000 CPS. Although this actual difference is measurable, its practical significance for most applications is very small.

COMBO MONITOR

From September-October, 1958

THE FIRST GADGET RACK ACCESSORY is a combination keying monitor, modulation indicator and field strength measuring instrument.

CONTINUOUSLY CHECKING your transmitter signal—and your *fist* too—is easy with this versatile unit. It requires only three tubes and two germanium diodes. A plate and post chassis, shown in the side view, Fig. 1, automatically provides a thru-panel mounting for the 6E5 indicator *eye* tube.

The signal to be monitored is fed into the unit from an external pickup antenna on pin 10 of the interconnecting cable system, as shown in the schematic diagram, Fig. 2. A 100-ohm potentiometer adjusts the signal level applied to the 6BE6 mixer tube. The position of the function switch, S_1 , determines the operation of the remaining circuits, as follows:

CW—An NE-51 neon lamp relaxation oscillator generates an audio tone which is mixed with the RF signal from the transmitter. This produces a modulated RF signal in the 6BE6 plate circuit, tuned to the transmitter frequency.

After detection by a 1N34 diode, the resulting audio signal is amplified in the left-hand 12AX7 triode and appears in the headphone circuit (pin 5 of the bus-bar system). Signals from the station receiver, applied on pin 11, are also fed into the headphone circuit by the right-hand 12AX7 triode.

However, whenever the transmitter key is pressed, rectified RF voltage from the 1N34 is applied to this stage as a negative bias, disabling it.

Thus, receiver audio is present in the headphone circuit when the key is *up*, and the NE-51 audio tone is heard when the key is *down*. This function is similar to the popular *Monitone* circuit¹.

CARRIER LEVEL—In this position of S_1 , an RF signal from the transmitter results in application of negative bias from the 1N34 to the grid of the 6E5 *eye* tube. This causes the unlighted portion of the circular fluorescent target on the end of the 6E5 to narrow or close entirely, indicating relative carrier level.

MODULATION—In this position of S_1 , modulation on a transmitter signal, detected by the 1N34 diode, appears in the headphone circuit. This audio signal also is rectified by a second 1N34 (located between S_1 and the 6E5 in Fig. 2), applied as a negative bias on the 6E5 grid and causes the *eye* to close in accordance with the modulation on the transmitter signal.

THE MODEL SHOWN was constructed on a 2½-inch-wide panel and a 2¼-inch-wide chassis plate. Parts locations on the chassis layout diagram, Fig. 3, are not critical and may be changed to suit available components. Good construction practice—short leads, isolation of signal and AC power circuits, related components grouped together, etc.—should be followed, however.



FIG. 1. SIDE VIEW of the COMBO MONITOR unit. Corner posts connecting the panel and chassis are 3 inches long. Those for the 2 x 2¼-inch mounting plate for the 1-megohm potentiometer are 1½ inches long. All posts are tapped for 6-32 screws at both ends.

PARTS LIST

C₁... Midget mica-insulated trimmer capacitors connected across L₁ in each coil; see COIL TABLE for values.

C₂... 100-mmf mica (Or, 75 to 150 mmf, see text, page 8).

NE-51... 1/25th-watt neon glow lamp; requires miniature bayonet socket.

P₁... Male 11-pin octal plug (Amphenol 86-PM11).

S₁... 2-circuit, 3-position, single section, non-shorting tap switch (Mallory 3223J).

FIG. 2. COMPLETE SCHEMATIC DIAGRAM for the COMBO MONITOR. Chassis grounds in the model were made at the points indicated. All capacitances are in mmf; all resistors 1/2-watt composition, unless otherwise specified.

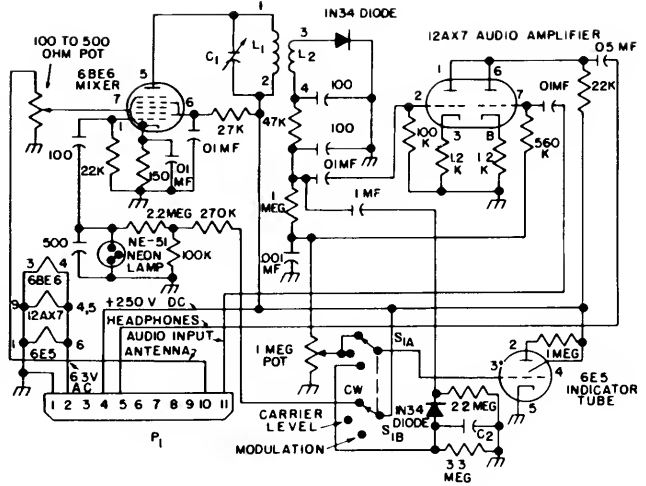

ADJUSTMENT IS SIMPLE, once all circuits in the COMBO MONITOR are working properly. Plug in a coil for the band on which the transmitter is operating before applying power to the unit. Modulate the transmitter 100 percent (check this with an oscilloscope, borrowed or otherwise), turn S₁ to **MODULATION** and adjust the 100-ohm signal level potentiometer until the 6E5 eye barely closes.

Remove the modulation from the transmitter, turn S₁ to **CARRIER LEVEL**, and adjust the 1-megohm potentiometer so that the 6E5 eye just closes, but does not overlap. The monitor is now calibrated to indicate 100-percent amplitude modulation of a transmitter. The 1-megohm potentiometer can

now be locked in position.

Each time the monitor is used on a different band, simply turn S₁ to **CARRIER LEVEL** and adjust the 100-ohm signal level control so that the 6E5 eye barely closes. Then return S₁ to the **MODULATION** position and the monitor is ready for use on a modulated signal.

1 J. W. Paddan, "The Manitone," September, 1948, QST, page 22; also C. V. Chambers, "The Manitone—Model 1951B," May, 1951, QST, page 29.

NOTE: The disclosure of any information or arrangements herein conveys no license under any patents of General Electric Company or others. In the absence of an express written agreement to the contrary, the General Electric Company assumes no liability for patent infringement (or any other liability) arising from the use of such information by others.

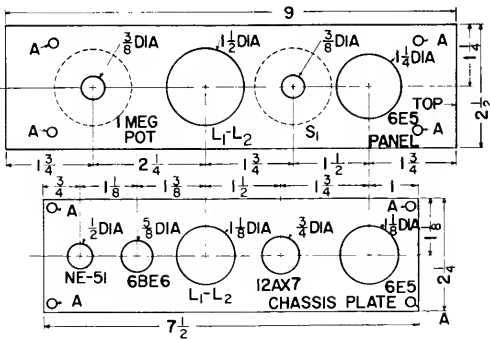

FIG. 3. PANEL AND CHASSIS PARTS LAYOUT used for this model. Small holes for socket and terminal strip hardware are not shown and should be located from those parts.

COIL TABLE—COMBO MONITOR

All coils wound with No. 24 enameled wire on 1-inch diameter, 4-prong coil forms (Millen, No. 45004; ICA, No. 1108B). On 3.5- and 7-megacycle coils, L₂ is wound over the pin-2 end of L₁, with a layer of plastic insulating tape between. On 14-, 21- and 28-megacycle coils, L₂ is wound next to pin-2 end of L₁.

BAND (MC)	uh	L ₁ turns	length	L ₂ turns	C ₁ (mmf)
3.5	42	52 (clasewound)	1 1/8"	16	4—50
7	13	24 (clasewound)	1/2"	12	4—50
14	7	16 (clasewound)	3/8"	8	3—12
21	3.6	12 (spaced wire dia.)	5/8"	6	3—12
28	2	7 (spaced wire dia.)	3/8"	4	3—12

Somehow the problem of how to switch the rig and associated equipment on and off seems to sneak up on a fellow unsuspectingly. He concentrates on his transmitter, receiver, converters, VFO and the other pieces of equipment and when he gets them all working suddenly realizes he doesn't have any way to operate them without flipping a dozen or so separate switches.

Then he has to scramble around hunting in handbooks and magazines and calling up his friends to get ideas for a control unit of some sort. Of course, it's not a difficult problem, and there are endless ways of solving it.

We present this solution—found in the shack of W2GYV—as one more suggestion to add to the pile. This is a 7-inch control panel with a 4 x 17 x 3-inch chassis mounted as shown.

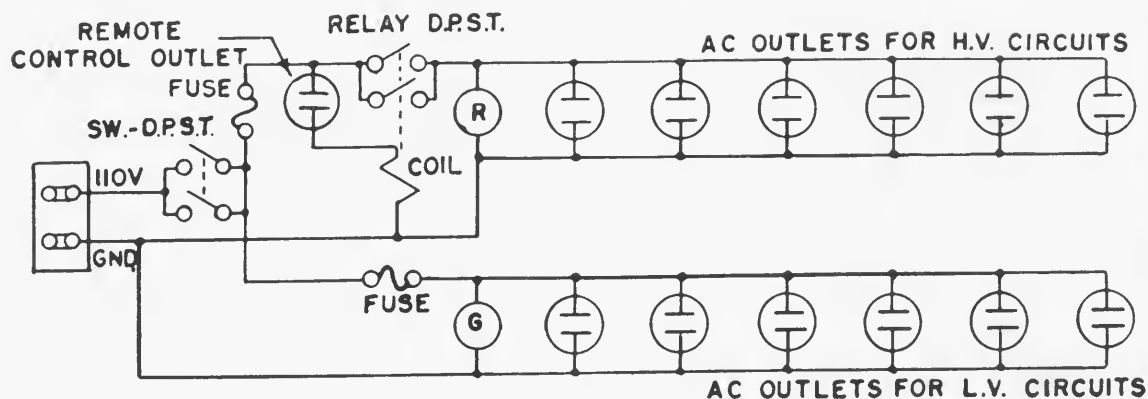
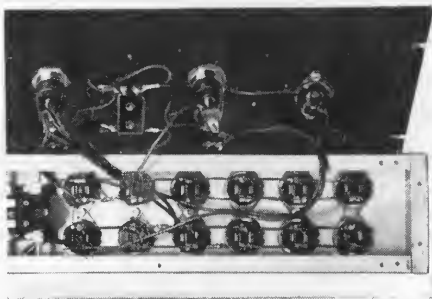

The circuit is simple and provides for remote control via the a-c type female outlet on the front of the panel. On the rear of the unit are two rows of a-c outlets—both supplying 110-volt a-c. The bottom row of six outlets is controlled by the front panel switch and is used for filament circuits in other pieces of equipment. The top row of outlets is controlled by the same switch plus the relay, and offers 110-volt a-c for the high-voltage plate transformers of various pieces of equipment.

An interesting feature of the circuit is that the relay coil is connected in the grounded side of the 110-volt a-c circuit. This method of connecting the coil eliminates any possibility of the relay being actuated if the hot lead in the remote control cable should accidentally become grounded. Incidentally, the relay used here is a double-pole type to provide a wide margin of current-carrying capacity and to halve the possibility of poor contact because of dirt or corrosion. A single-pole relay can be used.

The toggle switch shown is a heavy-duty, double-pole type to insure plenty of current-carrying capacity. The fuses used should be chosen to just carry the total current that will be drawn in their respective circuits.

The photographs show the construction clearly. Note that the mounting plates for the a-c outlets are overlapped to fit neatly in the chassis. Nothing in the construction is critical and the builder can make whatever variations are necessary to suit his purpose.

One excellent feature to add would be an interlock switch in series with the remote control outlet.

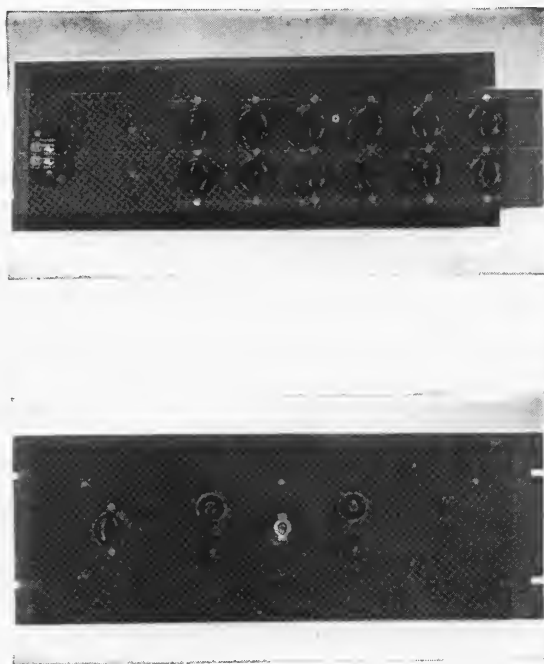

POWER SUPPLIES FOR SIDEBAND

ABOUT POWER SUPPLIES



another Ham News first

From January-February, 1954

Here, for the first time, is a revealing discussion of how transient oscillations in the conventional power supply filter spoil the performance of an otherwise good rig—and what can be done to correct the difficulty.

What is dynamic regulation in a power supply? Because the literature in this field is exceedingly sparse, perhaps a good way to start is to take two common definitions and directly relate them to the subject at hand, thus:

Static—Relating to forces in equilibrium (as d-c plate voltage and current in a rig transmitting a continuous unmodulated carrier).

Dynamic—Relating to moving forces (as d-c plate voltage and current under typical operating conditions in the average amateur CW, AM or SSB rig).

Keeping these definitions in mind will help in understanding just what goes on inside the conventional plate power supply which ordinarily consists of a center-tapped step-up transformer, rectifier tubes, and a two-section choke-input filter to reduce ripple. Since such supplies have been used since the introduction of the mercury-vapor rectifier, one might think that just about all the "bugs" would have been smoked out by now. Well, many bugs have been eliminated and, as a consequence, manufacturers of transformers and chokes now proudly offer what they term "matched power supplies"—sets of components for which they publish ratings, voltage regulation curves, and ripple output to be expected. These "matched" components make up power supplies that do perform as the published data indicates.

LOSS OF VOLTAGE

However, poor *dynamic* regulation in these conventional power supplies means distortion of signal output—alteration of actual radiated intelligence—almost without exception in CW, AM and SSB rigs. These faults exist no matter how good a *static* regulation figure is indicated by d-c input instrumentation. This comes about in the conventional power supply because transient oscillations excited in the filter rob the rig of voltage during a sizable portion of the time it is sorely needed. Hams who light-heartedly pass this effect off as "instantaneous," thereby implying it is of

no consequence, may want to examine their power supplies more critically after studying the test data presented below.

Consider the meaning of the voltage regulation curve usually given for the ordinary rectifier-filter combination. This is a "static" curve, obtained by loading the supply to certain currents, reading the voltages across each load, and then plotting the results. Such a curve is useful, but it tells us only what the *average* voltage will be at any *average* current value—*because the instruments used to measure these values respond only to average quantities*. Figure 1 shows just such an acceptably good regulation curve in which the voltage drops about 10% or so from no load to full load on an *average* basis.

But is it the average load, voltage and current alone that we are interested in? What kind of loads do our amateur transmitters present to their respective power supplies? Do we transmit intelligence with average loads—or with a complex pattern of instantaneous loads?

VOLTMETERS MISLEADING

Consider the final stage of a CW transmitter. At key-up the load is zero, or, at most, a rather small one. When the key is closed, the maximum load current is drawn. Now does the power supply follow the same curve that was plotted under static or slowly varying loads? An ordinary voltmeter might lead one to think so.

But look at Figure 2! This is a photograph of a cathode-ray oscilloscope which shows how the voltage varies with time in the ordinary power supply when the load is suddenly applied as in keying a CW rig. The solid upper line shows the no-load output of the supply—820 volts; the lower solid line represents zero volts. The lower waving line is a 60-cycle timing wave which permits reading the actual load voltage (represented by the upper oscillating line) at any fraction of a second from the instant the load was applied. The spot on the oscilloscope was started as the key closed to a 200-milliamper load. (The steady current

rating on the test supply is 250 milliamperes.)

Note how the load voltage dips suddenly to less than a third of the no-load voltage line, then wildly overshoots the line and oscillates about until it finally settles down to the average loaded voltage of 760 volts—which is the same as the static loaded output voltage shown in the curve of Figure 1 for a 200-milliamper load.

(Incidentally, the ripple under load is visible on the right-hand portion of the load voltage curve of Figure 2, but is fairly small compared with the extravagant excursion of the voltage in the period immediately following the application of the load.)

A d-c voltmeter that was connected across the line at the same time merely dropped from 820 to 760 volts and gave no indication of the actual turmoil immediately after keying!

EFFECT ON CW OPERATION

Is this turmoil anything to worry about? Well, the final stage in a CW transmitter generally runs Class C, and the transient oscillation shown across the power supply modulates each character with that same wave form quite independently of any keying filter that may be provided for click reduction. This, then, is the signal envelope—somewhat poorer than ideal!

How long is a dot or a dash in seconds? That depends on the operator for the most part, of course. But this transient oscillation certainly lasts for a considerable portion of the average CW dot or dash, because as can be seen from the timing wave of Figure 2, the voltage does not settle down to a steady ripple until more than a tenth of a second has elapsed. And as anyone who has played with timing in radio or photography work knows, a tenth of a second is far from what is normally thought of as "instantaneous."

When the load is removed (key up), the power supply voltage behaves as photographed in Figure 3—another wild peak, with the oscillation finally settling down to the no-load line. Of course, in this case there is no "on the air" effect, but the filter condensers and all other connected equipment are subjected once again to this voltage turmoil. This may explain why every once in a while a ham's whole rig is blown to kingdom come when he shuts it off.

The oscillograms shown apply only to single keying actions. Fast keying conditions intensify the transients shown in Figures 2 and 3.

EFFECT ON PHONE OPERATION

So much for CW loads on the common garden variety power supply. Now before the phone men start laughing up their sleeves at their brass-pounding brethren with "hand-modulated" rigs, let's take a close look at Class AB₁, AB₂, and B modulators operated with conventional power supplies.

It is characteristic of these modes of operation to draw average plate current which is a function of the modulating signal. Thus, the modulator load is similar to the on-off type of load experienced in a keyed CW transmitter, and the power supply transient so induced can be a real hazard to good quality. Because of the relatively sluggish action of a d-c plate current instrument (which tends to indicate current flow averaged over about half a second or so) the actual cyclic or syllabic transient load presented to the power supply is much greater than one would be led to believe by just reading the plate milliammeter.

What happens when the power supply behaves as in Figure 1? The answer is high distortion and loss of required peak power because most of the supply voltage just is not there part of the time it is needed by the modulator, and so the modulator tubes cannot draw the peaks of plate current that the grid drive on the modulator stage says should be drawn.

And remember, distortion tests made with steady tones will not show this "dynamic" distortion because the drain on a power supply induced by a steady tone is constant when averaged over one-half of the period of the test tone wave—relatively short compared to a filter transient which lasts more than a tenth of a second.

EFFECT ON SSB OPERATION

Single-sideband transmitters employing Class AB₁, AB₂, or B RF stages present the same type of load to their respective power supplies—and, as a result, also introduce considerable distortion in the radiated signal.

About the only types of emission in common use which do not suffer "on the air" losses as a result of transient filter oscillations are NBFM and FSK. (No transients are excited in the filter because the load is steady.) Linear amplifiers used with AM signals overcome this dynamic power supply regulation problem, but the carrier efficiency of this mode of operation is so low that use of linear amplifiers in amateur AM transmitters is not common. Similarly, constant current (or Heising) modulation for AM is another case where dynamic power supply regulation is not of primary importance. Grid modulation systems—control, screen or suppressor—also side-step the dynamic regulation problem but are inherently low-efficiency systems at best. In all these modes of operation, the only important power supply considerations are adequacy of rating and ripple filtering.

What can be done to improve the dynamic regulation of the conventional power supply? Let us follow the steps that were taken in the shack of W2KUJ to attack the problem.

THE SOLUTION

It became apparent that merely improving the ripple attenuation by adding more filter sections affected the dynamic regulation very little. So the first step was to increase the capacity of the existing filter from 2 microfarads to 5 microfarads per capacitor. The result appears in Figure 4—which shows excellent ripple filtering but only slightly reduced voltage excursions as compared with the transient of Figure 2.

Next, the two 5-microfarad capacitors of the two-section filter were connected in parallel to make a single-section filter (with the two chokes left in series). As shown in Figure 5, the voltage excursions are not greatly changed in magnitude, but have a less complex pattern—comparable, in fact, to that of a simple damped oscillation. But here again, the oscillation is excited in the filter by the suddenly-applied load.

The next step in the test was to use 45 microfarads of capacity as the final element of the filter. The dynamic regulation performance responded nicely, as shown in Figure 6. Note the reduction of magnitude of voltage swing and lowering of the resonant frequency of the filter as compared with Figures 2, 4 and 5.

FINAL DESIGN

This encouraged a final design in which 90 microfarads of capacity rendered the curve shown in Figure 7. Here the dynamic regulation is just slightly greater than the static regulation, which, incidentally, measures 9.34%—quite good enough for almost any amateur transmitter. The "break" characteristics of this final design are pictured in Figure 8. Use of more capacity would improve the dynamic characteristics of the power supply correspondingly because the resonant frequency of the filter would be lowered even farther. (For more detailed theory on the dynamic characteristics of plate power supplies see "Designer's Corner," page 8)

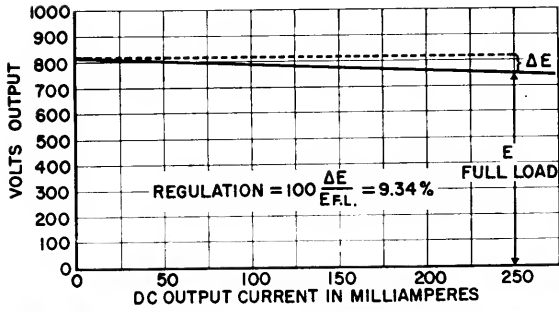

FIG. 1 Static regulation curve (C_a, C_b any value)

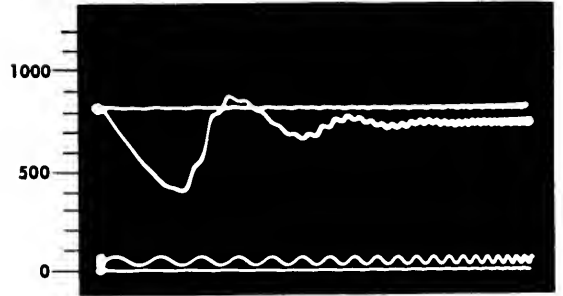

FIG. 5 Load applied ($C_a=0; C_b=10$ mfd)

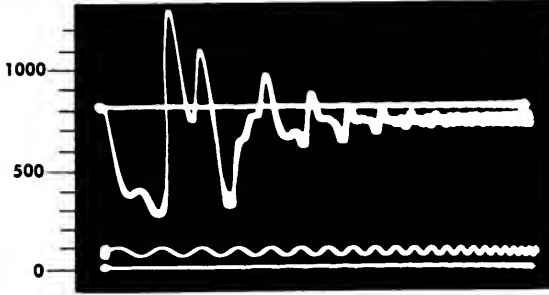

FIG. 2 Load applied ($C_a=C_b=2$ mfd)

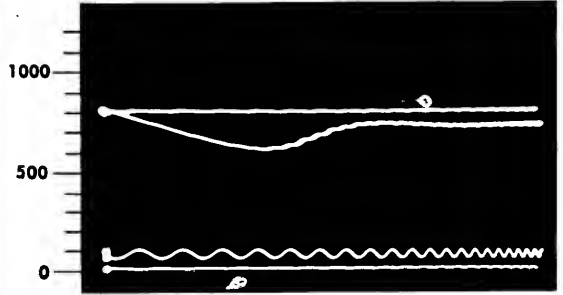

FIG. 6 Load applied ($C_a=0; C_b=45$ mfd)

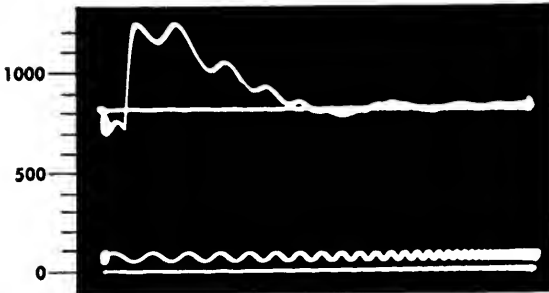

FIG. 3 Load removed ($C_a=C_b=2$ mfd)

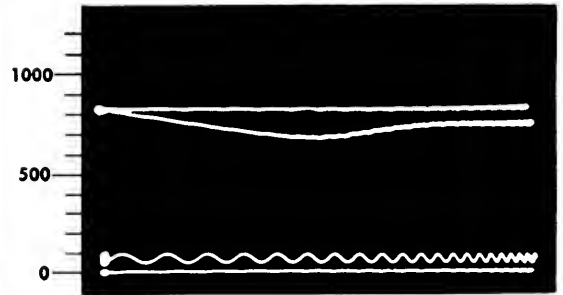

FIG. 7 Load applied ($C_a=0; C_b=90$ mfd)

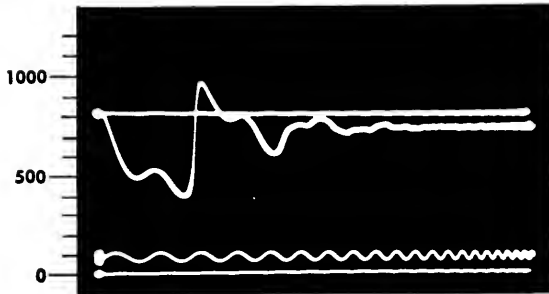

FIG. 4 Load applied ($C_a=C_b=5$ mfd)

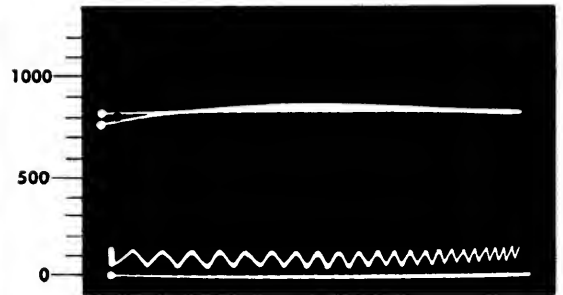
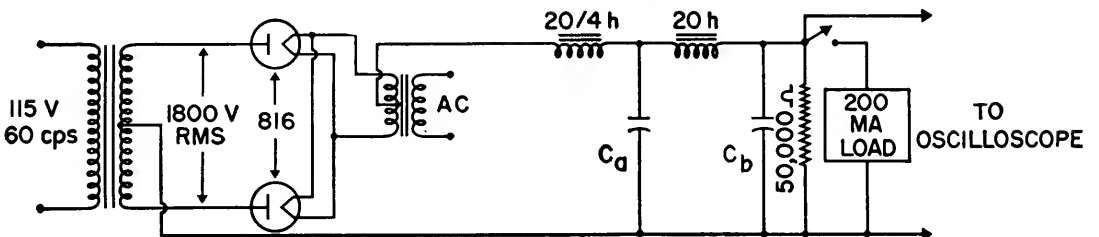

FIG. 8 Load removed ($C_a=0; C_b=90$ mfd)

Above data taken with this 750 V/250 ma d-c supply (see text):



two power supplies



1500 VOLT

750 VOLT

The dynamic characteristics of the average amateur power supply are those characteristics which become apparent in the operation of the supply when it is in actual use under average amateur operating conditions. In most amateur operations this means rapid intermittent application and removal of widely varying loads.

Meters will not measure the extensive voltage drops and peaks which are induced by varying the load—and as a result it has become somewhat traditional to regard such voltage excursions as “instantaneous” and “of little consequence.”

However, as demonstrated in the tests reported in the last issue of G-E HAM NEWS, these voltage excursions are somewhat more serious than is generally believed. The oscillograms showed that when normal load is applied d-c output voltage will drop to as low as a third of the no-load voltage, then wildly overshoot the no-load level, drop again, and so on—even in a power supply which has an acceptable static regulation figure.

Instantaneous oscillations? That depends on the definition of the word *instantaneous*. As these oscillations were actually photographed on an oscilloscope along with a 60-cycle timing wave, it was shown that the transient oscillations lasted well over a tenth of a second—enough time to competently modulate every CW character and distort at least a fair portion of the first syllable of every word a phone man utters.

Experiments showed the oscillations were directly related to the resonant frequency of the power supply filter—and that the simplest solution to the problem was to lower the resonant frequency by adding capacity to the filter. It was found that addition of sufficient capacity would smooth out the dynamic regulation curve so that it would nearly coincide with the conventional static regulation curve of the supply.

However, high-voltage oil capacitors cost money—lots of it. In order to economize, at least in the sense of

not running these newly designed power supplies a great deal higher in cost than conventional supplies of the same ratings, electrolytic capacitors have been specified in series-parallel combinations together with voltage-equalizing resistors.

Electrolytic capacitors generally are, we believe, better than they are cracked up to be in amateur circles. True, they may not last as long as oil capacitors, but as they have been improved considerably since first introduced, it was felt they were well worth trying. Those who still feel squeamish about using electrolytics may, of course, put in oil capacitors of the same value with equally good results. However, it is felt the electrolytics offer more capacity per year, per dollar.

In obtaining the unusually high capacity via the series-parallel methods shown in the circuit diagrams, it is important to make sure that all the equalizing resistors are used. This will insure operation of each capacitor well within its voltage rating.

The can of each electrolytic capacitor is its negative terminal. The capacitors in the series arrangement at the negative (chassis) end of the string may be mounted directly on the chassis with the metal mounting rings supplied with each capacitor. However, the remaining capacitors must be installed with cans insulated not only from the chassis but also insulated from the cans of the capacitors higher up in the string. Careful examination of the circuit diagrams will make this clear.

To provide this insulation a variety of mounting methods will suggest themselves to the builder. The method shown here is to mount capacitors that must be insulated on a piece of textolite which in turn is mounted in a hole of appropriate size cut in the chassis.

In addition, it is strongly recommended that a shield be placed over those capacitors whose cans operate above ground. *This shield is to protect the operator—not the capacitors!* Remember that the can of an electrolytic capacitor is generally thought of, subconsciously, as being grounded. The builder may have

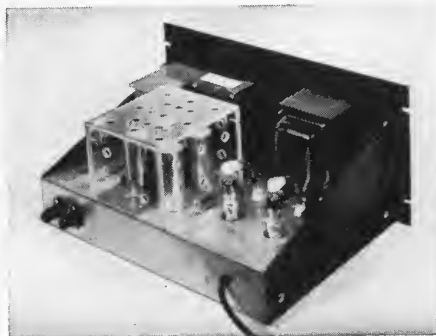
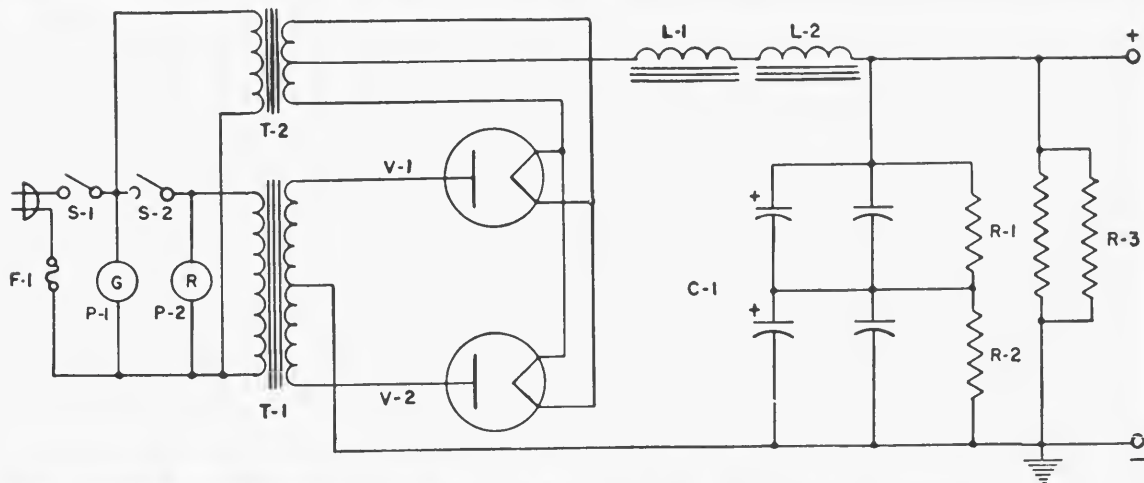
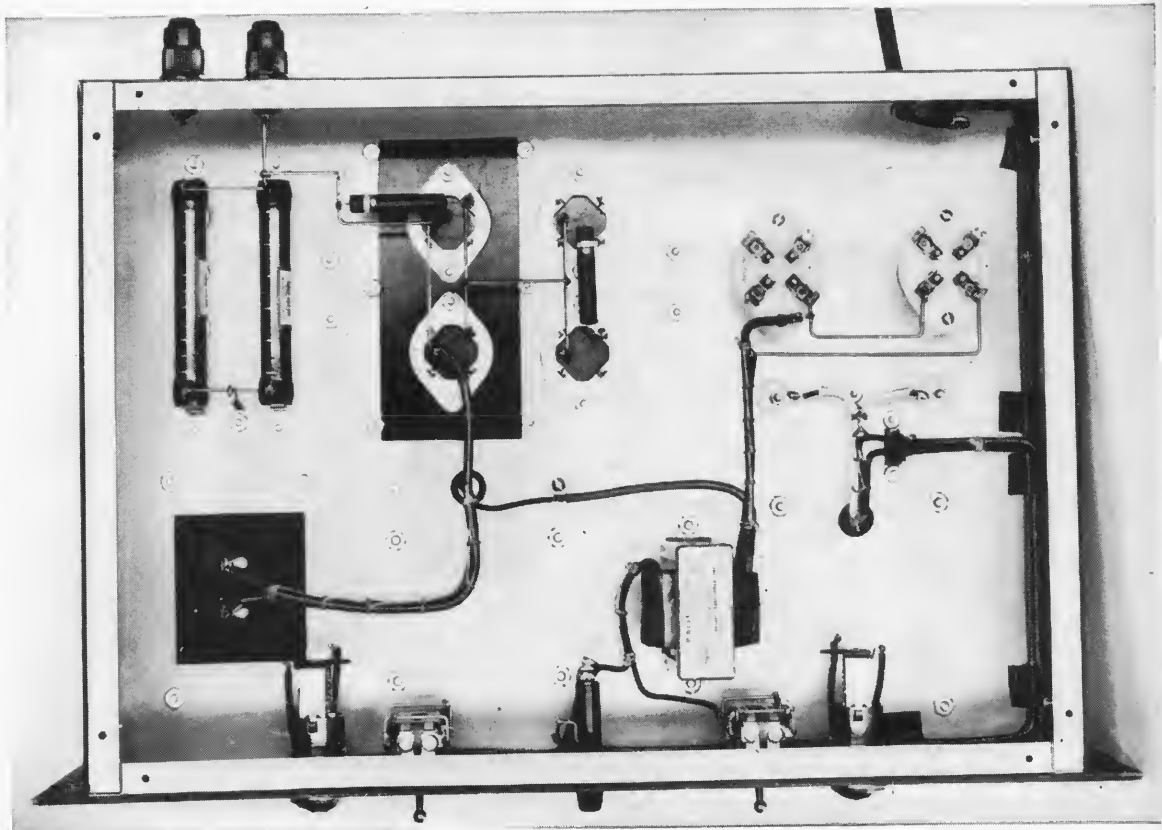

750 v/250 ma Power Supply

- S₁, S₂—SPST toggle switch (preferably power type, 12A)
- T₁—920-0-920 plate transformer (Stancor PC-8305)
- T₂—2.5 v, 5A filament transformer (Stancor P-6133)
- V₁, V₂—GL-816
- L₁—20/4 h at 30/300 ma, 80 ohms D-C resistance swinging choke (Stancor C-1720)
- L₂—20 h, 225 ma smoothing choke (UTC S-31)
- C₁—125 or 90 mfd (4 Sprague TVL-1760 or 1850)
- R₁, R₂—200,000 ohms, 2 w composition
- R₃—50,000 ohms, 25 w (see text)
- P₁, P₂—110 v pilot lamp
- F₁—5A slow-blowing fuse

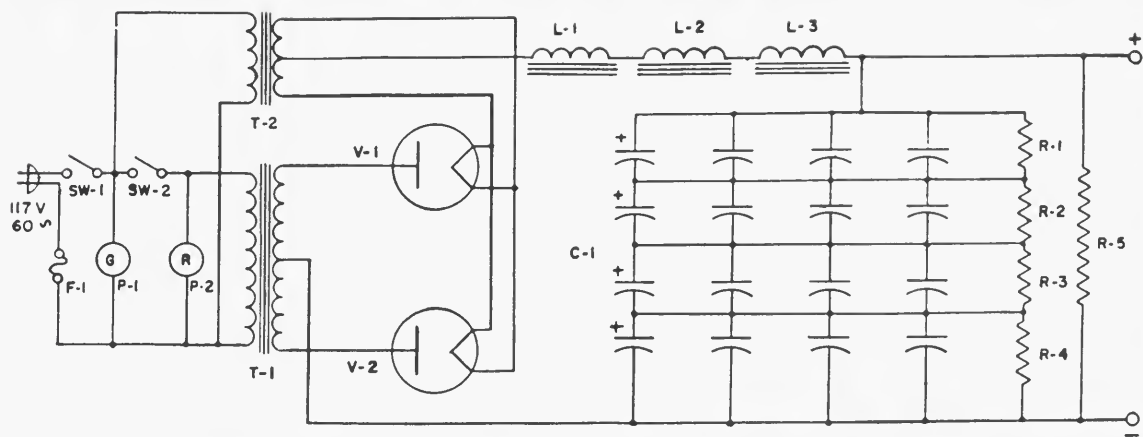
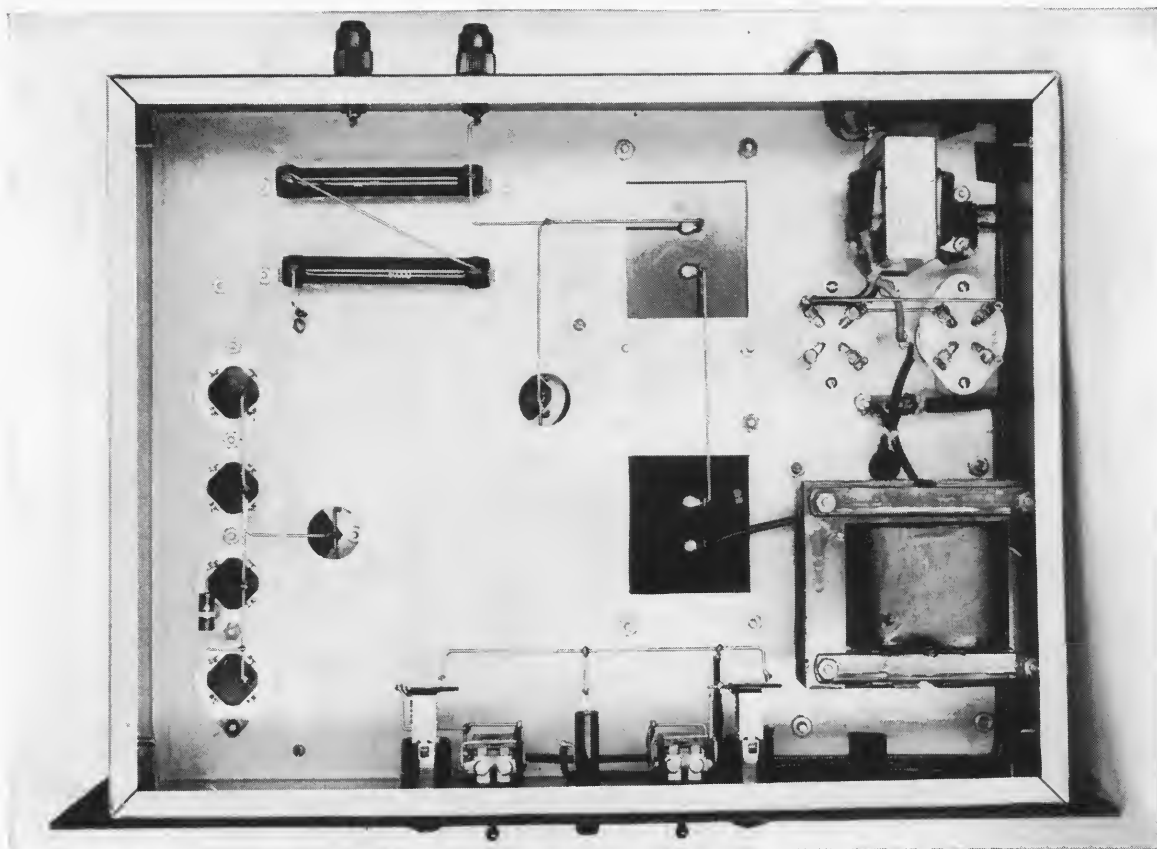

1500 v/250 ma Power Supply

- S_1, S_2 —SPST toggle switch (power type, 12A)
 T_1 —1790-0-1790 plate transformer (Stancor PT-8314)
 T_2 —2.5 v 5A filament transformer (Stancor P-6133)
 V_1, V_2 —6X4
 L_1 —20/4 h at 30/300 ma, 80 ohms D-C resistance swinging choke (Stancor C-1720)
 L_2, L_3 —20 h, 225 ma smoothing choke (UTC S-31)
 C_1 —125 or 90 mfd (16 Sprague TVL-1760 or 1850)
 R_1, R_2, R_3, R_4 —100,000 ohms, 2 w composition
 R_5 —100,000 ohms, 50 w (see text)
 P_1, P_2 —110 v pilot lamp
 F_1 —10A slow-blowing fuse

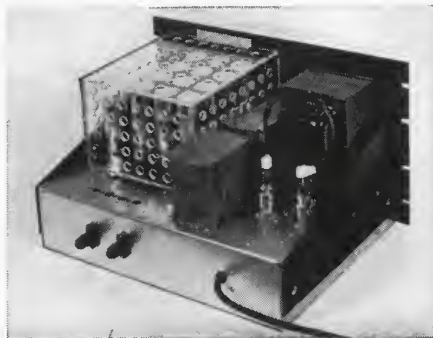

the danger fresh in his mind while he is constructing the power supply and for a relatively short time thereafter. But will he remember, say, a year from now when he opens the rig to service some component that some of those cans are well above ground? And will a visitor to the shack—or the junior operator—inquisitively poking around inside the supply, ever know—even after he touches one—that those cans are “hot”?

Take no chances! Time and effort taken now to build a shield for these above-ground cans can save a life in the future. The shields shown were fashioned out of sheets of plexiglass drilled with ventilation holes. Such refinement is not necessary, of course. Shields can be fabricated from almost any type of metal. Hardware cloth is inexpensive, easy to handle and when corner joints are soldered it makes a fairly solid shield.

While the sixteen capacitors in the 1500-volt supply may seem like a staggering number, this amounts only to a bank of four-by-four which can occupy as little space as an eight-inch square. Actually, of course, only 12 of these have to be insulated from the chassis.

Remember, the more output capacity, the better the dynamic performance of the power supply will be. If possible, it will be best to use the 125-microfarad capacitors (Sprague TVL 1760, or equivalent). As demonstrated in the previous article, it is difficult to see how one can get too much capacity built into the power supply.

On the other hand, it is important not to overdo the inductance, since the static regulation is proportional to the total d-c resistance of the chokes.

A word about the fact that 225-milliampere smoothing chokes are here used in 250-milliampere power supplies. In a search for chokes of the lowest possible cost and d-c resistance, the design work proceeded on the assumption that the published rating meant, in effect, that this choke has 20 henries inductance at a 225-milliampere load—and might very likely carry additional current. As a test, three of these chokes were put under continuous 250-milliampere loads for 24 hours with no adverse effects. Few amateurs run their power supplies at the so-called “maximum” ratings, but those who regardless of the foregoing wish to put in chokes of higher current rating and are willing to pay the additional cost can do so. The chokes specified in the accompanying circuits were chosen with this in mind—that is, to get as high inductance and as low resistance as possible at the lowest possible cost. If other chokes than those specified are used, the resistance should be checked.

A word about the bleeder resistors used in these two power supplies. To run the resistors as cool as possible, provide a maximum of safety and save space, two methods were tried. In the smaller supply, two 100,000-ohm, 25-watt resistors were used in parallel to obtain the 50,000 ohms required. (While “Dividohms” were used because they were readily available at the time, fixed resistors will serve, of course.) This method doubles the power rating and provides a measure of safety in the event one of the resistors burns out.

Of course, the larger the resistance, the smaller the wire used in a resistor—and the more prone it is to burn out. Frankly, we prefer the second method—employed in the 1500-volt supply—of using two 50,000-ohm, 50-watt resistors in series to obtain the 100,000 ohms of resistance necessary in this power supply. This, too, doubles the power rating and provides as large wire as feasible.

A multitude of refinements can be made on a power supply, of course—one of the most worth while being a safety interlock arrangement in the final installation. However, outside of including fuses, switches and pilot lamps in the accompanying circuit diagrams, refinements have been left to the individual builder to include as suits his purpose. In deviating from the power supplies described herein, however, care should be taken to insure proper insulation at all points.

Wire with insulation suitable for the voltage involved should be used not only in the power supply unit itself, but also in making interunit connections to control panels and transmitters. Adequate mechanical strength should be maintained in the mounting of the heavy transformers and chokes. Input and output connectors can be of any type suitable for the voltages concerned.

The two switches included in the diagrams permit separate control of the rectifier filament power and plate power. The first time the supply is used, a filament warm-up of at least one minute is recommended before applying plate power. This will allow the mercury within the GL-816 tubes to distribute itself properly. This also applies whenever the tubes are removed and replaced. In subsequent operation, it is necessary to allow at least ten seconds for heating the filaments before applying plate power. The power supply should be operated only when the tubes are in a vertical position.

When operated within ratings, these power supplies should give the builder the most satisfactory performance ever experienced with any power supply.

One more thing: **DON'T LOAD THE POWER SUPPLY WITH YOUR BODY!** Be certain to short-circuit the output terminals before working on anything connected with the supply—even when it is turned to the “OFF” position and even if the a-c line cord is pulled out. Remember that 100 microfarads of capacity holds a lot of “soup” and a burned-out bleeder will allow dangerous voltages to remain in the filter for a matter of *minutes* after it is turned off!

- Trapping Transients -

HOW TO PHOTOGRAPH VOLTAGE DROPS

The oscillograms shown on page 3 of this issue of G-E HAM NEWS were taken with a 5-inch cathode-ray oscilloscope fitted with an oscillograph camera.

The power supply output voltage is fed to the vertical deflection plates of the oscilloscope through a voltage divider while a single horizontal sweep is started by the same switch that applies the load to the power supply. The load, incidentally, was a vacuum tube biased to cut off for no-load conditions and made to take load by controlling the grid voltage with the switch. This type of load simulated the load applied to a power supply feeding a keyed stage in a transmitter.

On one occasion the transient voltage developed in the power supply was so high that the multiplier resistor of a voltmeter reading the output voltage of the supply under test arced across and burned out the meter. That time the voltmeter *did* give some indication of the turmoil in the power supply following a suddenly applied load!

* * *

Good dynamic regulation in a power supply (see G-E HAM NEWS, Volume 9, Nos. 1 & 2) is particularly important in an SSB transmitter to obtain the peak output of which the amplifier is capable. And with so many fellows turning to SSB (over a thousand, according to what we hear), the question continually has come up as to just what practical advantage you get with 100 or so microfarads of capacity in your power supply filter. In other words, a lot of fellows ask if 20 or 30 microfarads won't do just as well in practical operation.

The answer lies in the oscillograms of our issue of Volume 9, No. 1. They show the sort of dynamic regulation you get with varying amounts of capacity. They show how performance improves continually as you add capacity. You will note, however, that the performance has improved tremendously by the time the capacitance reaches a value of 45 microfarads. After that, although the improvement continues with additional capacitance, the improvement naturally is smaller.

Designer's Corner—Designing Power Supplies

Some time ago when checking out my SSB transmitter I ran into a dismaying situation.

Checks with a steady audio tone showed the rig was putting out all that could be asked for. But voice peaks measured on the oscilloscope would not come anywhere near the same level. The cause was not easy to determine, but it finally turned out to be tremendous voltage drops in the power supply during a considerable portion of each syllable as a result of filter oscillations. In a more recent test I actually photographed these voltage drops, as pictured in the foregoing article.

The problem is one which involves effective damping of filter resonance or reducing the coupling between the load variations and the resonant system of filter chokes and capacitors—or both—without sacrificing efficiency or static regulation, and without overloading the rectifier tubes or any other power supply component. All this must be done without increasing the cost of the final design appreciably over that of the conventional power supply. It sounds a lot like "eating your cake and having it too," since what we have seen in the oscillograms of Figures 2, 3, 4 and 5 is commonly accepted although rarely suspected performance.

THE SOLUTION

The practical solution of the filter resonance problem involves these basic steps:

1. Reducing the Q of the filter without increasing its series resistance, and
2. Increasing the energy storage in the last filter element.

The first step could be achieved by shunting capacitors and chokes with resistors, but if this is done the peak current handled by the rectifiers would go up, the static regulation would be poorer, and a great deal of power would be wasted in the damping resistors—that is, the efficiency of the power supply would be low.

Since the Q of the choke is $\frac{X_L}{R}$ where X_L is the inductive reactance at a given frequency, and R is the effective series resistance of the choke at the frequency considered, and since the Q of the filter is equal to the Q of the choke (if the capacitor has relatively little effective series resistance), Q can be lowered by decreasing X_L or increasing R . If R is increased the static regulation will suffer as a consequence, so the approach should be through decreased X_L . Since $X_L = 2\pi fL$ a low product of $f \times L$ is desired. In the interest of efficiency and static regulation, practical limits are placed on the value of L , the inductance of the choke, so the factor f is the only one left to be altered.

NEED LOWER FILTER Q

What determines f ? The resonant frequency of the filter is the quantity f in question. To a first approximation $f = \frac{1}{2\pi\sqrt{LC}}$ where C is the capacity of the filter condenser with which L resonates. Therefore, the Q of the filter can be lowered by increasing C , and this helps in attainment of the second basic step listed above.

What would have happened if L had been increased by a factor of 9, instead of increasing C by the same

factor? The resonant frequency would have been lowered as much, but the series resistance probably would increase by about the same factor (it certainly would if 9 times the number of identical chokes had been used) and the static regulation would be nine times that indicated by Figures 1, 2, 4, 5, 6, and 7, or 84%, a drop from 820 volts, no load, to 131 volts at 200 MA load! The Q would be the same in the filter, but the total performance would be so sadly degraded that such a supply would be valueless except for salvage of parts.

In some cases, the best design would be one in which both the chokes and the condensers were increased in value until suitable dynamic performance was obtained. In high-voltage supplies this begins to pay dividends since the "critical" inductance increases with voltage for a given minimum or bleeder current drain, and high-voltage capacitors begin to get expensive. Static regulation depends on the DC resistance of the chokes (together with the equivalent series resistance due to the plate transformer) but a given total equivalent resistance in the chokes and transformer yields less *percentage* voltage drop as the operating voltage is increased.

TWO POWER SUPPLY DESIGNS

We have designed two power supplies which promise to provide excellent dynamic regulation, good static regulation and good ripple filtering. Best of all, these supplies are not expensive ones. The first supply has a continuous rating of 750 volts/250 MA output for moderate and low power applications, while the second is rated at 1500 volts/250 MA. One nice thing about it all is that the builder may utilize the principle we have explained and proven in order to build other supplies which exhibit equally good (or better) dynamic regulation. Either power supply is ideally suited for CW transmitters, Class B modulators, linear amplifiers (such as the Lazy Linear² or the Power Peaker³), or any application where the voltage and average current requirements are within the ratings given. The final samples of these two power supplies were not completed by the time this issue of G-E HAM NEWS went to press, but construction details will be given in the March-April issue.

—W2KUJ

¹ See G-E HAM NEWS Volume 7, No. 2, page 6; also, the ARRL Handbook. In these treatments only static regulation is considered. Good background material, though.

² G-E HAM NEWS Volume 4, No. 4

³ G-E HAM NEWS Volume 7, No. 5

HOW TO PHOTOGRAPH VOLTAGE DROPS

The oscillograms shown on page 3 of this issue of G-E HAM NEWS were taken with a 5-inch cathode-ray oscilloscope fitted with an oscillograph camera. In this photograph Don Norgaard, W2KUJ, is shown just before he opens the shutter of the camera and applies the load to a power supply he is testing for dynamic regulation.

The power supply output voltage is fed to the vertical deflection plates of the oscilloscope through a voltage divider while a single horizontal sweep is started by the same switch that applies the load to the power supply. The load, incidentally, was a vacuum tube biased to cut off for no-load conditions and made to take load by controlling the grid voltage with the switch. This type of load simulated the load applied to a power supply feeding a keyed stage in a transmitter.

On one occasion the transient voltage developed in the power supply was so high that the multiplier resistor of a voltmeter reading the output voltage of the supply under test arced across and burned out the meter. That time the voltmeter *did* give some indication of the turmoil in the power supply following a suddenly applied load!

Don has been a regular contributor to G-E HAM NEWS and has been responsible for the design of the *Harmoniker*, the *Lazy Linear*, the *Signal Slicer*, the *SSB, Jr.*, and other pieces of ham gear described in G-E HAM NEWS.



The Detrimental Effects of Tuned Power Supply Filters

Since the G-E HAM NEWS issues covering dynamic power supply regulation were published, many radio amateurs have commented that a parallel-tuned circuit immediately following the rectifier would eliminate the need for placing high filter capacity across the power supply output. For full-wave or bridge rectifier fed from a 60-cycle power line, the resonant filter would be tuned to 120 cycles. Series-resonant circuits, shunted across the power supply, also have been suggested as a solution.

After extensive checking, the following reasons were found why resonant filters are not a practical solution to good dynamic power supply regulation problems.

1. It is very difficult to calculate the value of capacity which must be placed either in series or parallel with a given filter choke to form either a series or parallel resonant circuit, respectively, tuned to 120 cycles. The effective inductance of an iron-core choke changes with varying current drain, usually decreasing as the current flow increases, and therefore, the resonant frequency of the filter will increase with increasing current flow through the choke.

2. Although such a resonant portion of the filter can reduce ripple on a steady-

state basis, such action generally is at the expense of poor transient response, or ringing effects. The static regulation of such a filter can be better than the conventional type when due account is taken of the effective series resistance of the filter system. However, this is purely an economic consideration, since high Q (low resistance) chokes can be made but at relatively high cost.

3. Either of the resonant systems will cause rather high peak rectifier currents as compared with a properly designed choke-input filter, and in some cases can result in destruction of the rectifier tubes. Since we are interested in helping customers and radio amateurs obtain satisfactory tube life and operation, we have avoided suggesting methods such as resonant filters.

4. In conclusion, resonant filters are a step in the wrong direction, since it is resonance in power supply filters that causes poor transient voltage regulation. Our approach was as follows: (1) to lower the resonant frequency; (2) thereby lowering the Q of the filter; (3) increase the energy storage in the filter; and (4) decreasing the coupling of transient loads into the filter, considering the source of the transient to be the load circuit.

DUAL-VOLTAGE POWER SUPPLIES

From September-October, 1957

TUBE BRIDGE



GERMANIUM FULL BRIDGE



GERMANIUM HALF BRIDGE



DUAL FULL WAVE



Need two high voltages for your medium power transmitter? Build a dual-voltage power supply from one of these circuits, tailored to the contents of your junk box, or from inexpensive television receiver replacement components.

—Lighthouse Larry

Preparation of a simple and stable 100-watt transmitter for the November–December, 1957 issue demanded an equally simple dual-voltage power supply. Our solution: Combine plentiful replacement-type components in bridge and full-wave rectifier circuits, smooth with a high-capacity filter, and package compactly in a corner of the transmitter cabinet.

—Lighthouse Larry

GENERAL CIRCUIT DETAILS

A majority of amateur transmitters in the medium power class (60 to 200 watts) require at least two different high voltages, usually about 300 volts for the oscillator and intermediate stages, and 600 to 750 volts for the power amplifier.

These voltages may be obtained by any of three means: A separate power supply for each high voltage required; or single power supplies having either a transformer with a tapped high-voltage winding feeding separate full-wave rectifiers; or a single bridge rectifier with the lower DC voltage obtained from a center tap on the high-voltage winding. The two latter circuits will be described here.

As the simplified schematic diagram of a vacuum tube bridge rectifier in Fig. 1 shows, the cathodes of diode tubes A and B, connected to opposite ends of the high-voltage winding, each should be powered from a separate filament transformer having adequate insulation. In addition, a third filament transformer is required for diodes C and D, having their cathodes connected together. Thus, tube bridge rectifiers with directly heated cathodes have complex heater circuitry.

Development of rectifier tubes having separate cathodes electrically isolated from the heater has made possible tube bridge rectifiers with fewer filament transformers. Publication of the "Economy Power Supply" circuit¹ a few years ago suggested this innovation, in addition to more efficient utilization of replacement type radio and television receiver power transformers in dual-voltage power supplies. Type 6X5-GT indirectly-heated full-wave rectifier tubes were suggested for V_1 and V_2 in the original "Economy" type bridge circuit, shown in Fig. 2A. The 6X5-GT may be operated with the cathode 450 volts positive or negative with respect to the heater.

Since the DC output current rating of the 6X5-GT is only 70 milliamperes, connecting each pair of tube plates in parallel still limits the maximum output current of the original economy power supply to about 140 milliamperes. By substituting a pair of similar full-wave rectifier tubes, 6AX5-GT's, for the 6X5-GT's, the same circuit is capable of supplying up to 300 milliamperes total current when operated into a choke input filter with up to 700 volts AC applied to the bridge rectifier.

A single filament transformer, T_3 , powers both tube heaters, but three precautions should be taken to keep the heater—cathode voltage on V_1 and V_2 within the rating. First, one side of the heater circuit should be connected to the center tap on the high-voltage transformer winding. Second, the high-voltage transformer, T_1 , should not be turned on until the heaters of V_1 and V_2 reach operating temperature. Third, V_1 and V_2 should be hot before heater voltage is applied to V_3 , the full-wave rectifier forming the other two legs of the bridge circuit.

In the circuit of Fig. 2A, V_1 and V_2 are heated by T_3 when the main power switch, S_1 , is closed. Primary power for the high-voltage transformer, and the filament transformer for V_3 , T_4 , should be applied by closing S_2 at least 30 seconds later than S_1 . If S_2 is closed im-

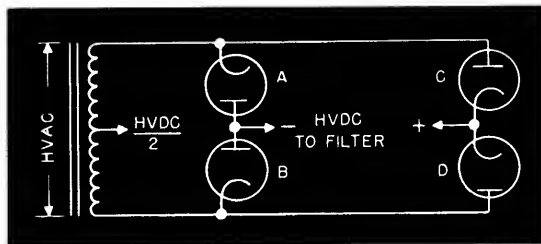

Fig. 1. Basic schematic diagram of a bridge rectifier circuit using four single diode tubes.

mediately after S_1 , a negative voltage will appear at the "HV/2" output terminal until the heaters of V_1 and V_2 warm up. Heater power for V_3 may be taken from T_1 if a suitable winding is available.

A single 5U4-GB or 5R4-GYA will suffice for V_3 with maximum current drains of 250 milliamperes or less. If sufficient heater power is available, two 5U4-GB, 5R4-GYA or 5V4-GA tubes may be connected in parallel to reduce the voltage drop through the tubes.

Choke input filters, as shown in Fig. 2B, are recommended for both the high-voltage and half-voltage outputs, even though the output DC voltage under full load will be about 10 percent lower than with a capacitor input filter. However, the peak current through the rectifiers is much lower with choke input.

Four 125-mfd, 450-volt electrolytic capacitors, C_1 to C_4 , connected in a series—parallel circuit, are desirable for good dynamic voltage regulation, as described in "ABOUT POWER SUPPLIES" (See G-E HAM NEWS, January-February and March-April, 1954, Vol. 9, Nos. 1 and 2, for details). These capacitors, plus a single smoothing choke in each filter, reduce the AC ripple appearing on the output voltage to a fraction of one percent. Additional low-resistance filter chokes may be connected in series with L_1 to further reduce the resonant frequency of the filter circuit.

A simple circuit by which the primary voltage applied to T_1 may be adjusted also is shown in Fig. 2A. All heater windings on T_1 are connected in series (the windings should be in phase) and placed in series with the primary. The actual voltage on the primary will then be either higher or lower by the total voltage of the heater windings. A single-pole, double-throw switch, S_3 , applies normal primary voltage with the switch arm as shown, or alternate primary voltage with the switch arm in the "up" position.

If single 6.3- and 5-volt windings are connected in series, the primary voltage can be changed to about 10 percent above and below normal. A 15 percent change either way will result from connecting one 5-volt and two 6.3-volt windings all in series. It is thus possible to boost the output voltage of a transformer high-voltage winding 50 to 80 volts if desired. Or, the high voltage can be reduced to a suitable value, if it is too high, by reversing the connections to the heater windings. However, the AC high voltage from T_1 should not exceed the rating of the rectifiers under any conditions.

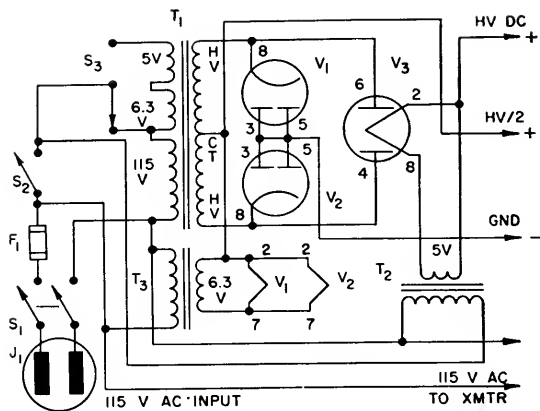

Fig. 2A. Schematic diagram of the "Economy" bridge rectifier circuit. Note that the heater supply winding for V_1 and V_2 is connected to the high-voltage-winding center tap.

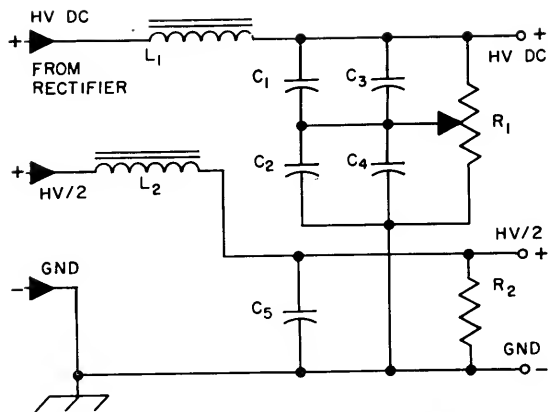

Fig. 2B. Schematic diagram of the dual choke input filter circuit recommended for use with all rectifier circuits described herein.

PARTS LIST

- C_1 — C_5 —125-mfd, 450-volt electrolytic (Sprague TVL-1760).
 F_1 —Small cartridge fuse and holder (3-ampere fuse for power supplies with up to 200 ma output, 5-ampere fuse for over 200 ma).
 D—Semiconductor rectifiers (See TABLE I).
 J_1 —2-prong male chassis power receptacle.
 J_2 —Female high-voltage connector.
 L_1 —8 to 20-henry, 200 to 500-ma smoothing choke, with 1600-volt insulation.
 L_2 —20-henry, 50-ma smoothing choke.
 R_1 —50,000-ohm, 50-watt adjustable resistor.
 R_2 —25,000-ohm, 25-watt resistor.
 S_1 —Double pole, single throw 3-ampere toggle switch.
 S_2 —Single pole, single throw 3-ampere toggle switch.
 S_3 —Single pole, double throw 3-ampere toggle switch.
 S_4 —2-pole, 3-position 3-ampere selector switch.

- T_1 , T_7 , T_8 —Replacement type radio or television receiver power transformer, approximately 700 volts, center-tapped, at 150–350-ma DC output, 5-volt and 6.3-volt heater windings.
 T_2 , T_9 , T_{10} —5-volt, 3-ampere transformer, 115-volt primary.
 T_3 —6.3-volt, 3-ampere transformer, 115-volt primary.
 T_4 , T_6 —Replacement type television receiver power transformer, up to 750 volts, center-tapped, at up to 400-ma DC output, 5-volt and 6.3-volt heater windings.
 T_5 —5-volt filament transformer; 3 amperes for one 5U4-GB; 6 amperes for two 5U4-GB's, 115-volt primary.
 V_1 , V_2 —G-E 6AX5-GT full-wave rectifier tubes.
 V_3 — V_6 —G-E 5R4-GYA, 5U4-GB, or 5V4-GA full-wave rectifier tubes (see text).
 V_7 —G-E 5R4-GYA or 5U4-GB full-wave rectifier tubes (see text).

By substituting the alternate primary circuit for T_1 shown in Fig. 3, any of three primary voltages may be selected. The center position on S_4 applies normal line voltage to T_1 ; the HIGH position connects the heater windings to add to the line voltage; and the LOW position reverses the heater windings and thus subtracts from the line voltage.

The primary voltage switching circuits and high-voltage filter circuit are recommended for the other rectifier circuits which follow. Of course, pilot lights, relay control circuits, cabinet safety interlock circuits, indicating meters, output voltage regulators and other extra features may be added as desired. Only the basic circuitry has been shown here.

The maximum output current rating given replacement type power transformers by most manufacturers apply for these conditions: One, continuous operation; two, a full-wave rectifier circuit; and three, a capacitor input filter. For intermittent amateur type operation, approximately the same output current (and nearly twice the output power) can be drawn from the same transformer without excessive heating under the following conditions: First, operating into a bridge rectifier which more efficiently utilizes the high-voltage winding; and second, a choke input filter which reduces the peak current and power loss in the high-voltage winding as compared with a capacitor input filter.

It is a fairly simple matter to add the additional components to a good full-wave power supply to convert it to a bridge rectifier circuit and thus considerably increase the total DC output power obtainable from the supply. The only chassis-top space needed is for the two

6AX5-GT rectifier tubes. The extra filament transformer (T_3) and metal can or tubular type electrolytic capacitors (C_1 and C_3) can be located beneath the chassis.

SEMICONDUCTOR BRIDGE RECTIFIERS

Recent developments in the field of semiconductors have resulted in the marketing of highly efficient, moderate cost germanium, silicon and selenium rectifiers. Even though the maximum ratings usually apply to half and full-wave rectifier circuits, several identical semiconductor rectifiers can be connected into a bridge rectifier circuit. In a bridge circuit, the peak inverse voltage across each leg will be only half as much as in a half or full-wave rectifier for a given DC output

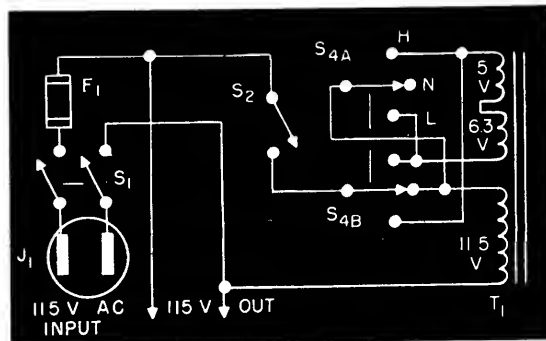

Fig. 3. Optional transformer primary voltage switching circuit. Additional heater windings may be added in series if available. All windings should be in phase.

¹Grammer, "More Effective Utilization of the Small Power Transformer," QST, November, 1952, page 18.

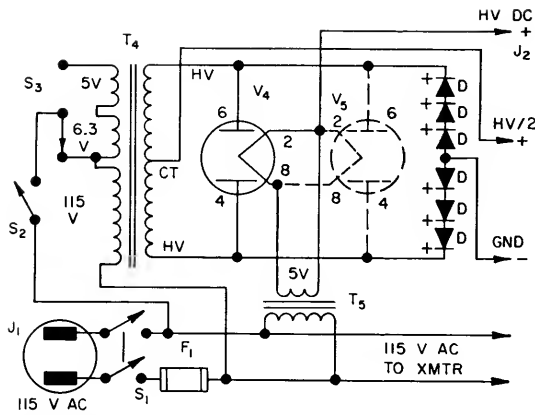

Fig. 4. Schematic diagram of a bridge rectifier converted from a full-wave rectifier by adding three series-connected semiconductor rectifiers in each leg. The optional rectifier tube, V_5 , should be included to handle maximum current drains between 275 and 550 milliamperes.

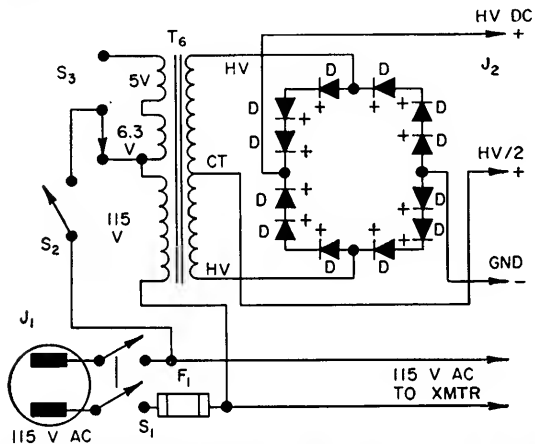

Fig. 5. Schematic diagram of a semiconductor bridge rectifier having three rectifier cells in each leg.

voltage. Thus, each rectifier in a bridge circuit will withstand nearly twice the rated AC voltage without exceeding the peak inverse voltage rating.

Series-connected semiconductor rectifiers can be employed in the place of rectifier tubes in the two added legs in the previously described "Economy" bridge circuit, as shown in Fig. 4. This arrangement is adaptable to a power supply in which the extra filament transformer winding is not readily available.

The DC high voltage is taken from the heater circuit of V_4 , and approximately half this voltage will be delivered from the center tap on the high-voltage winding, formerly connected to ground in the full-wave circuit. The lower voltage is rectified by the two strings of semiconductor rectifiers operating in a full-wave circuit. An additional full-wave rectifier tube, V_5 , may be connected in parallel with V_4 to reduce the tube voltage drop if the additional heater power is available from T_5 .

A bridge circuit in a new dual-voltage power supply can employ semiconductor rectifiers in all four legs. This circuit, shown in Fig. 5, also is suitable when an existing power supply is being rebuilt. Three series-connected rectifier cells are shown in each leg of these circuits. Only two rectifiers per leg may be necessary for certain operating conditions, as shown in the circuits of Fig. 6A and 6B.

Table I shows the maximum recommended operating voltages and currents for several popular semiconductor rectifiers in the aforementioned circuits. The 550-milli-

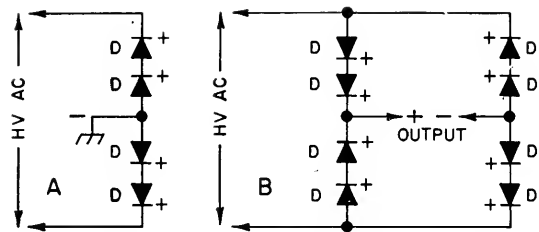

Fig. 6. Schematic diagrams showing (A) four and (B) eight rectifier cells used in half and full semiconductor bridge circuits in Figs. 4 and 5, respectively.

TABLE I—SEMICONDUCTOR RECTIFIER DATA

Rectifier	Ckt. Fig.	Quant. Rect.	Max. AC Input V.	Max. DC Current
1N93	4	6	660 V.	300 MA.
1N93	5	12	660 V.	300 MA.
1N153	4	6	660 V.	550 MA.
1N153	5	12	660 V.	1000 MA.
1N158	6A	4	810 V.	550 MA.
1N158	6B	8	810 V.	1000 MA.
1N539	6A	4	840 V.	550 MA.
1N539	6B	8	840 V.	1500 MA.
1N540	6A	4	1120 V.	550 MA.
1N540	6B	8	1120 V.	1500 MA.
300-MA Selen. Rect.	4	6	990 V.	500 MA.
	5	12	990 V.	500 MA.
	6A	4	660 V.	500 MA.
	6B	8	660 V.	500 MA.

ampere rating shown for the combination tube and semiconductor rectifier circuits is the maximum current that two 5U4-GB tubes in parallel will deliver. Note that the 1N158, 1N539 and 1N540 rectifiers are capable of handling far more current than the average power transformer will deliver.

A bridge rectifier made from replacement type selenium rectifiers costs less than a comparable germanium or silicon bridge, but the full-load voltage drop is about four times higher. Also, the temperature of the air surrounding selenium rectifiers should be kept below 115 degrees Fahrenheit. Germanium and silicon rectifiers are rated for normal operation in temperatures up to 130 degrees. In addition, the silicon rectifiers will operate at much higher temperatures with reduced current output.

TWO-TRANSFORMER DUAL FULL-WAVE RECTIFIER

The high-voltage windings of two similar power transformers may be connected in series, instead of in parallel, and used in a power supply having separate full-wave tube rectifiers for the full and half DC output voltages. As shown in Fig. 7, the midpoint between the windings becomes the negative output voltage connection. The center taps of the two windings are connected to one full-wave rectifier, V_6 , and the outer ends feed the other full-wave rectifier, V_7 . The windings must be in phase, otherwise there will be practically no DC output voltage from either rectifier.

The diagram shows four heater windings all connected in series to provide a greater adjustment in the primary voltage than is possible with two or three heater windings on a single transformer. All windings should be in phase.

A 5U4-GB, 5V4-GA, or 5Y3-GT full-wave rectifier is suitable for the moderate current usually drawn from the lower output voltage tap. A 5U4-GB may be used for V_7 only when the full secondary voltage of each transformer is below 550 volts. A 5R4-GYA full-wave rectifier at V_7 can be operated with up to 950 volts per transformer.

Even for intermittent amateur service, the total current drain from both DC output voltage taps should not exceed the rated current of each transformer by more than 40 percent. The voltage regulation of this circuit is not as good as with a single power transformer, because the rectified current flows through the high-voltage windings only in one direction and tends to saturate the transformer cores at high current drains.

CONSTRUCTION DETAILS

The test model power supplies shown on the front page, and in the top views, Fig. 8, were constructed on 7 x 12 x 3-inch-deep aluminum chassis (Bud AC-408). When power transformers and chokes weighing more than 10 pounds each are used, a steel chassis is advisable, even though it is harder to cut and drill. The heavy components were placed at opposite ends of the chassis mainly to balance the weight load, with the rectifiers between them. The chassis size and parts placement may be changed to suit the equipment which the supply is to power.

The electrolytic capacitors should not be crowded against components which radiate considerable heat, such as the tubes. Capacitors C_1 and C_3 in the filter circuit diagram, Fig. 2B, were mounted on the insulating fiber mounting plates furnished with the capacitors. Since the metal cans of these capacitors are several hundred volts positive with respect to the chassis, fiber insulating sleeves should be placed over them. Holes $1\frac{1}{2}$ inches in diameter were cut in the chassis for these capacitors to prevent the mounting lugs from shorting to the chassis.

Filament transformers, small filter chokes, bleeder resistors and other small parts are mounted under the chassis wherever convenient. The wiring is run along the chassis corners and between components, then laced into a cable upon completion. External connections are made through suitable plugs and terminal strips. A

high-voltage type connector is recommended for the full DC output voltage.

Semiconductor rectifiers should be mounted atop the chassis, rather than under it, to allow adequate circulation of air around them. Rectifiers having insulated mounting feet may be fastened directly to the chassis in one or two rows. Small rectifiers having only leads in one or two rows. Small rectifiers having only leads can be mounted on a terminal board like that shown in Fig. 9. Connecting leads to the rectifiers are run up through rubber-grommeted holes in the chassis.

Another mounting method is recommended for selenium rectifiers in the half and full bridge circuits,

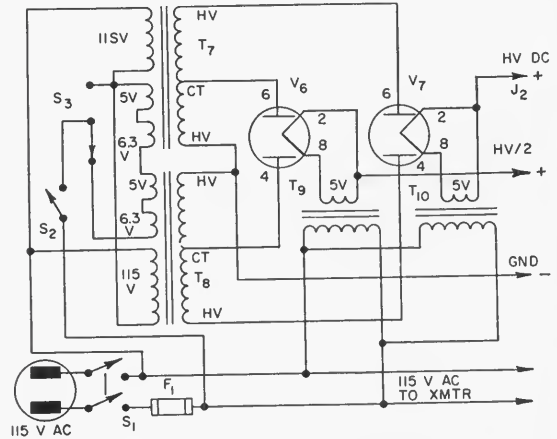

Fig. 7. Schematic diagram of a dual full-wave rectifier circuit using high-voltage windings of two replacement type power transformers in series. Extra "spaghetti" insulating tubing should be slipped over the transformer high-voltage leads to guard against insulation breakdown.

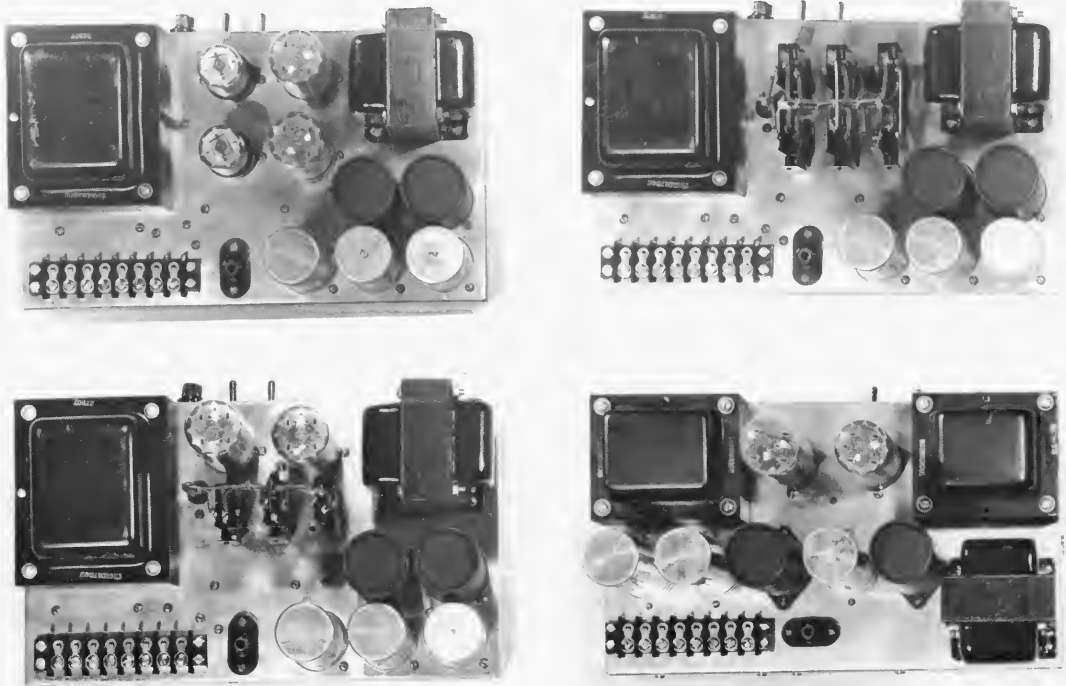

Fig. 8. Top views of the four types of power supplies shown on the cover. Note that the rectifiers are placed well away from the filter capacitors. Chassis size and layout may be varied to suit space requirements.

Figs. 4 and 5. The thin fiber tubes through which the rectifier fastening screws pass may not withstand the voltages involved, so four rows of three rectifiers each were fastened to the 5 x 5 x 1/4-inch-thick laminated insulating board (Textolite or bakelite), shown in Fig. 10. The bottom edge of this board was drilled and tapped for fastening screws which run up through the chassis. A perforated metal shield should be placed over both germanium and selenium rectifiers to prevent curious fingers from touching dangerous voltages!

OPERATION

Power supplies do not have to be tuned up or otherwise adjusted, but a wiring check is advisable before applying power for the first time. After turning on the AC power, both DC output voltages without a load, and with full load, should be checked. These may be raised or lowered by adjusting the transformer primary voltage, as previously outlined.

Output voltage tests were conducted on all power

supply circuits to obtain the comparative voltage regulation figures shown in Table II. When testing each power supply, the primary voltage was adjusted so that the high-voltage winding always delivered 700 volts AC regardless of the output current load. The figures thus will help determine the output voltage that can be expected from each type of rectifier when operated from a transformer having other than 700 volts AC output.

Other tests were run with the power supplies delivering twice the output current at which the power transformers were rated in full-wave rectifier service. After an hour of this torture, no components over-heated to the extent that they smoked or showed other signs of failure.

These tests, plus hundreds of hours of use in transmitters, offer proof that these simple power supplies made from low-cost components will "deliver the goods" in your 60 to 200-watt transmitter.

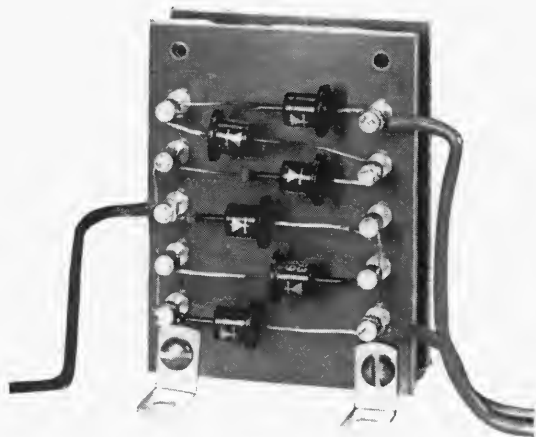

Fig. 9. View showing a suggested mounting arrangement for a group of lead-mounted germanium or silicon rectifiers on terminal boards. The boards were fastened together with bolts and spacers, then mounted on the chassis with small angle brackets.

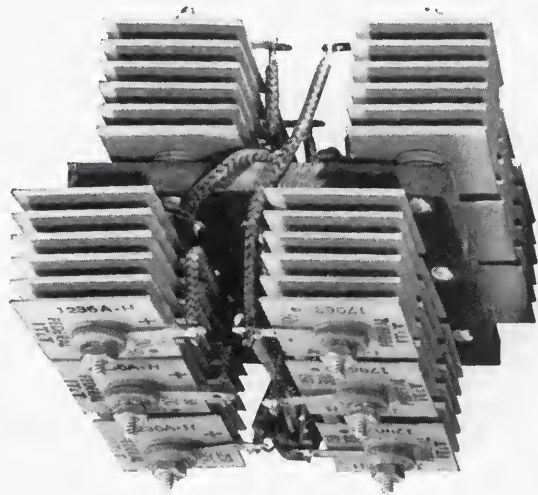

Fig. 10. Detail view of the suggested mounting method for the twelve selenium rectifiers. This assembly fits into the same area occupied by the other types of rectifiers shown in the top views.

TABLE II—POWER SUPPLY OUTPUT VOLTAGE MEASUREMENTS

POWER SUPPLY			OUTPUT—HV DC TERMINAL			OUTPUT—HV DC/2 TERM. WITH 50-MA LOAD AS LOAD IS VARIED ON HV DC TERM.		
CIRCUIT	FIG.	RECTIFIERS	NO LOAD	100-MA LOAD	200-MA LOAD	NO LOAD	100-MA LOAD	200-MA LOAD
TUBE BRIDGE	2A.	1—5U4-GB 2—6AX5-GT	720V.	580V.	550V.	300V.	260V.	240V.
TUBE BRIDGE	2A.	2—5U4-GB 2—6AX5-GT	725V.	590V.	560V.	300V.	260V.	240V.
COMBINATION BRIDGE	4.	1—5U4-GB 4—1N158	720V.	600V.	570V.	310V.	300V.	290V.
COMBINATION BRIDGE	4.	2—5U4-GB 4—1N158	725V.	605V.	575V.	310V.	300V.	290V.
GERMANIUM BRIDGE	6.	8—1N158	740V.	650V.	640V.	310V.	305V.	300V.
SELENIUM BRIDGE	6.	12—300-ma Selenium Rect.	735V.	630V.	610V.	305V.	280V.	265V.
TWO-XFMR FULL WAVE	9.	1—5U4-GB 1—5R4-GYA	725V.	580V.	520V.	290V.	275V.	265V.

Added Information on Dual-Voltage Power Supplies

Many requests have been received for information on whether transformers having higher voltage output can be used in the bridge rectifier circuits shown in Figs. 2A, 4 and 5 in the September-October issue; and in the full wave circuit of Fig. 7. In the circuit of Fig. 2A, the maximum total voltage from the transformer secondary we recommend is 750 volts. Otherwise, the maximum heater-to-cathode voltage rating of the tube 6AX5-GT tubes will be exceeded.

Type 6W4-GT, 6AX4-GT or 6AU4-GT single diode tubes used in the horizontal damping circuit of TV receivers have been timed in place of the type 6AX5-GT tubes. However, the 6.3-volt heater supply for these tubes should be connected to the negative side of the high voltage output, as shown in Fig. 11 below, (ground or chassis) instead of to the center tap on the transformer high voltage winding, as was done in Fig. 2A. in that issue. One or two 5U4-GB twin diode tubes, both powered from the same filament transformer, can be used for the other two legs of the bridge.

The TV damping diodes also may be used in all four legs of a bridge rectifier, as shown in Fig. 12 below. All four tube heaters may be powered from the same 6.3-volt heater supply, which should be tied back to the negative side of the high voltage output. Type 6W4-GT and 6AX4-GT tubes will deliver up to 250 ma of DC output current; and type 6AU4-GT's will deliver up to 380 ma.

Do not attempt to operate these tubes in the usual full-wave rectifier circuit, as shown in Fig. 13 below. Otherwise, the heater-to-cathode voltage rating will be exceeded when the tubes are operated from a transformer delivering more than 75 volts each side of the center tap. It is possible to operate these tubes in the same type of full-wave rectifier in which they are used in the grounded legs of bridge circuits; that is, with the plates tied together, and the cathodes connected to the ends of the high voltage winding. A DC output voltage just less than half the total transformer voltage will then be available from the transformer center tap, as shown in Fig. 14. (See below)

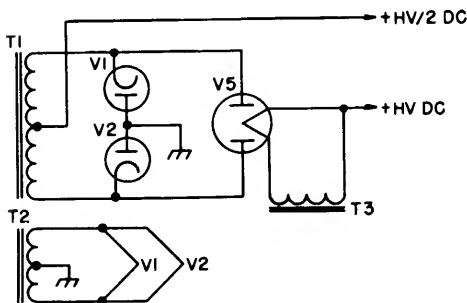

FIG. 11. "ECONOMY" TYPE BRIDGE CIRCUIT WITH TWO TV DAMPING DIODE TUBES AND ONE FULL-WAVE RECTIFIER TUBE.

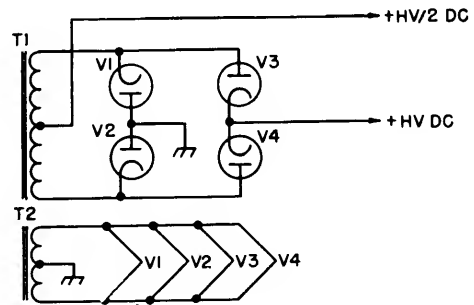

FIG. 12. BRIDGE RECTIFIER CIRCUIT USING FOUR TV DAMPING DIODE TUBES WITH ALL HEATERS POWERED FROM ONE LOW-VOLTAGE TRANSFORMER.

PARTS LIST FOR THESE CIRCUITS - FIGS. 11 TO 17

- D - Germanium, Selenium or Silicon semiconductor rectifiers. Sum of maximum peak inverse voltage ratings of rectifiers in each leg of bridge should be approximately equal to, but not less than the total RMS AC output voltage of high voltage winding on power transformer, T₁.
- T₁- Power transformer having total AC high voltage winding about 20 percent higher than desired full load DC output voltage from power supply. Current rating about equal to desired full load output current.
- T₂ - Filament transformer, 6.3 volts, current rating equal to total drawn by V₁ through V₄.
- T₃- Filament transformer, 5 volts, 3 amperes for one 5U4-GB or 5R4-GYA; 6 amperes for two such rectifiers.
- V₁--V₄--6W4-GT, 6AX4-GT or 6AU4-GT TV damping diode tubes.
- V₅--5U4-GB full wave rectifier for transformers having up to 550 volts output per plate; 5R4-GYA for up to 950 volts per plate.

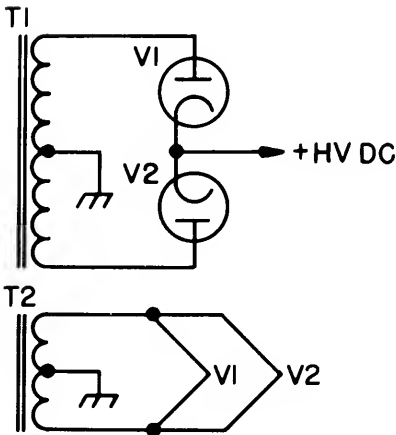

FIG. 13. FULL-WAVE CIRCUIT NOT RECOMMENDED FOR TV DAMPING DIODE TUBES.

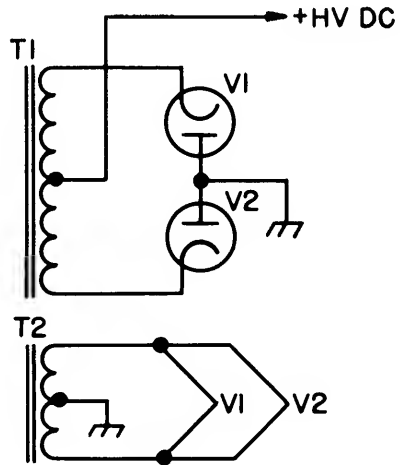

FIG. 14. FULL-WAVE CIRCUIT IN WHICH TV DAMPING DIODE TUBES MAY BE OPERATED WITHOUT EXCEEDING HEATER-CATHODE VOLTAGE RATING.

Some readers have expressed the opinion that we are operating the semiconductor rectifiers above their maximum peak inverse voltage ratings in the bridge circuits of Figs. 4, 5 and 6 of that issue. Note in Fig. 15 below that the current path through a bridge rectifier having two rectifier sections in each leg of the bridge actually flows through four rectifiers, and not two rectifiers, as apparently has been assumed. Thus, when 660 volts AC is applied across a bridge having a total of eight 130-volt RMS, 380-volt peak inverse rectifiers, each rectifier is withstanding a peak inverse voltage of only 234 volts. Even though the applied AC voltage per rectifier is 165 volts RMS, the peak inverse voltage in a bridge rectifier is only half that of a full-wave rectifier to which the same total AC voltage is applied.

The mathematics of this reasoning are as follows: With 660 volts AC (sine wave) applied across the bridge, the total peak inverse voltage will be 660 times 1.414, or about 935 volts. Dividing this across four rectifiers results in a peak inverse voltage per rectifier of only 235 volts. Although it should be possible to apply up to 266 volts RMS per rectifier to this circuit, it is best to be conservative and consider 212 volts RMS per rectifier as the maximum (300 volts peak inverse).

Germanium TV rectifiers produced by General Electric also may be used in these circuits, but they are recommended only for experimental and amateur type usage. The G-E commercial grade rectifiers specified in the G-E HAM NEWS article should be used for commercial applications. The G-E 1N1008 single section rectifier may be operated with up to 380 volts peak inverse, at a total bridge rectifier output current of 800 ma. The G-E 1N1016 two-section doubler type rectifier has two 380-volt peak inverse, 25-ma rectifiers in series. Thus, a single 1N1016 rectifier will replace two single section rectifiers having the same current rating.

Diagrams are shown below in Fig. 16 for connecting the G. E. 1N1016 dual section rectifier in a half-bridge circuit requiring three rectifiers, (top) and full-bridge (bottom) circuit requiring six rectifiers, with three rectifier sections in each leg. Connections for high voltage AC power, and the DC output voltage connections to the filter, are labelled.

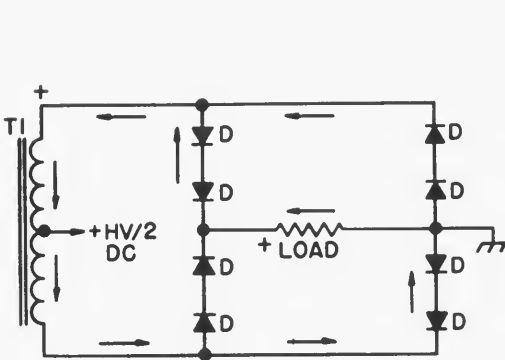

FIG. 15. SEMICONDUCTOR DIODE BRIDGE RECTIFIER CIRCUIT WITH ARROWS SHOWING PATHS OF DC CURRENT FLOW THROUGH RECTIFIERS FOR ONE-HALF OF THE A-C CYCLE. ARROWS REVERSE FOR OTHER HALF OF CYCLE.

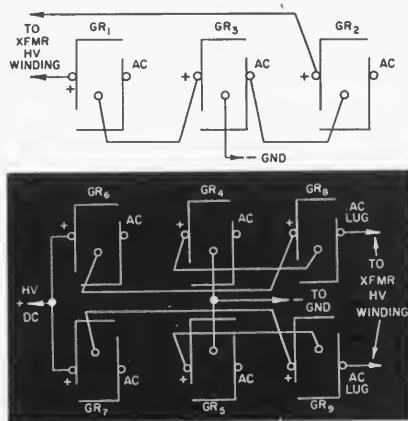

FIG. 16 CONNECTION DIAGRAMS FOR THREE G. E. 1N1016 RECTIFIERS IN HALF-BRIDGE CIRCUIT (TOP), AND SIX 1N1016 RECTIFIERS IN FULL BRIDGE CIRCUIT (BOTTOM).

In the G-E HAM NEWS diagram of Fig. 7 for a two-transformer full-wave rectifier circuit, transformers having higher voltage secondaries may be used, depending upon the ratings of the rectifier tubes used in the circuit. For example, a pair of transformers, each having up to 950 volts total secondary voltage, may be operated into a 5R4-GYA rectifier tube on the higher voltage output section. A 5U4-GB may be used with transformers delivering up to 550 volts each, or when the voltage taken from the center taps for the lower output voltage is less than 550 volts, provided that a choke input filter is used.

Another circuit for a dual-voltage power supply, which we did not publish may be made by connecting the output of two separate full-wave rectifiers in series. One full wave rectifier is operated with the high voltage winding center tap grounded, as shown in Fig. 17. The positive voltage from the cathode of this rectifier is then connected to the center tap on the high voltage winding of a second full-wave rectifier. A total current about one and one-half times the continuous duty current rating of the transformers may be drawn from this power supply when the transformer heater windings are not used.

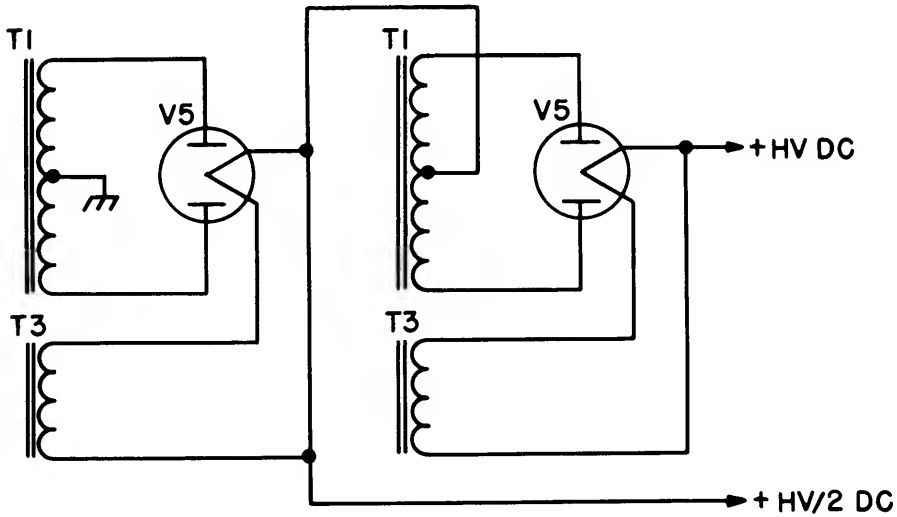

FIG. 17. CIRCUIT FOR CONNECTING TWO FULL-WAVE TUBE RECTIFIERS, EACH FED BY SEPERATE CENTER-TAPPED HIGH VOLTAGE TRANSFORMER WINDINGS, IN THE SERIES TO OBTAIN DOUBLE THE PLATE VOLTAGE OF ONE TRANSFORMER RECTIFIER COMBINATION.

HIGH POWER MOBILE POWER SYSTEMS



W8DLD and W8WFH, above, have designed and constructed high-power mobile amateur radio stations for their station wagons which give them home-station performance on the highway. *G-E HAM NEWS* is proud to present a series of three articles which describe their systems, starting in this issue. Techniques for power supplies, receivers, and linear amplifiers for CW and SSB communication will be covered.

MEET THE AUTHORS . . .

W8DLD — A. F. (Al) Prescott, is an engineer with the electronics laboratory at General Electric's Cuyahoga Lamp Plant.

W8WFH — W. C. (Bill) Loudon, is technical counselor in Discharge Advance Engineering at G-E's Large Lamp Department.

Both of these operations are located at General Electric's Nela Park, in Cleveland, Ohio, home of our world-famous Lighting Institute.

Al and Bill have amassed years of experience in developing radio equipment — and their 3-phase power system — for mobile use. Their present SSB installations reflect the results, and are nearly all home made, including the antennas, except for the Command set receivers. Their stations operate

on all frequencies from 3.5 to 29.7 megacycles, but their favorite channels for daily mobile operating are from 14,250 to 14,300 kilocycles.

Their phasing type SSB exciters have some unusual circuits and ideas, so the readers of *G-E HAM NEWS* will be seeing novel features of this equipment in coming issues. The receiving systems and a linear amplifier will be described in the next two issues.

Dramatic evidence of the reliability of their equipment was illustrated by their being able to keep three-times-daily schedules while separated at times by more than 2,000 miles during vacation motoring trips in 1959 and 1960.

MOBILE POWER SUPPLY IDEAS

From July-August, 1960

By A. F. Prescott, W8DLD, and W. C. Louden, W8WFH

TODAY'S MORE POWERFUL mobile amateur radio equipment can overload even the larger electrical systems in late model automobiles. Solve this problem by installing a constant voltage, variable-frequency, 3-phase, AC power system—large enough for even a kilowatt mobile rig—using the principles and ideas described in this article.

With many mobile radio installations now requiring 200 watts and more power from automotive electrical systems, it is usually necessary to run the car's engine when this equipment is operated for more than a few minutes at a time to avoid discharging the battery. The standard automotive electrical system, as shown in Fig. 1, just wasn't designed for this purpose.

Many commercial, police and taxi vehicles have 3-phase AC alternators installed to provide extra power for two-way radio equipment. One manufacturer, Leece-Neville, supplies either 6-volt, 100-ampere, or 12-volt, 50-ampere alternator systems, rated at 600 watts output (see page 2 for details).

However, the 600-watt limitation is due mainly to the rectifier connected to the alternator output to change the 3-phase AC cur-

rent into direct current, as shown in the block diagram of Fig. 2. Over 200,000 miles of field "testing" on the alternators installed to power W8DLD/M and W8WFH/M have proven this system capable of supplying more than 1-KVA of power, even under summer driving conditions.

Note that the rectifier is used mainly for battery charging and other normal needs of the automotive electrical system. The high voltage DC power supply can be fed directly from the alternator, avoiding the less efficient method of first rectifying the 3-phase AC power into direct current, and then obtaining high voltage with a dynamotor, transistorized D-C-to-DC converter, or vibrator power supply.

Voltage regulation of the alternator system is very good. The "variable frequency" mentioned above occurs from changes in engine speed, from 100 cycles with the engine idling, to nearly 1,000 cycles at top speed. However, modern power transformers, even though rated for 60-cycle operation, are capable of operating efficiently over this wide frequency range. And, usually the 60-cycle ratings may be considerably exceeded at the higher supply frequencies.

(continued on page 5)

FIG. 1. BLOCK DIAGRAM of a typical 12-volt DC automotive electrical system. Approximately 200 watts of power may be drawn on an intermittent basis to operate mobile radio equipment. Usually the automobile engine must be kept running if more than a few minutes operation of radio equipment is attempted to keep the storage battery charged.

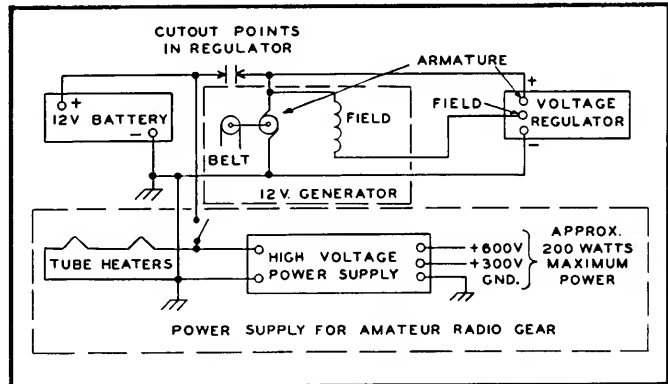
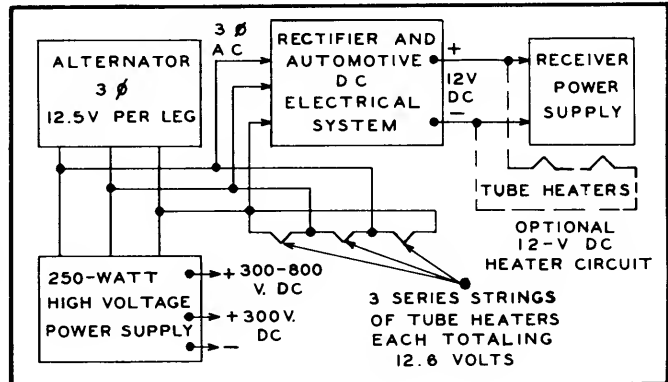

FIG. 2. BLOCK DIAGRAM of an alternator type automotive generating system which can be installed in place of the conventional DC generator. The alternator generates 3-phase AC power which is then rectified and used to charge the storage battery. The AC power is fed into a 3-phase high voltage power supply of up to 250 watts capacity. Tube heaters in radio equipment may be operated either from the DC battery power, or from the AC alternator output.



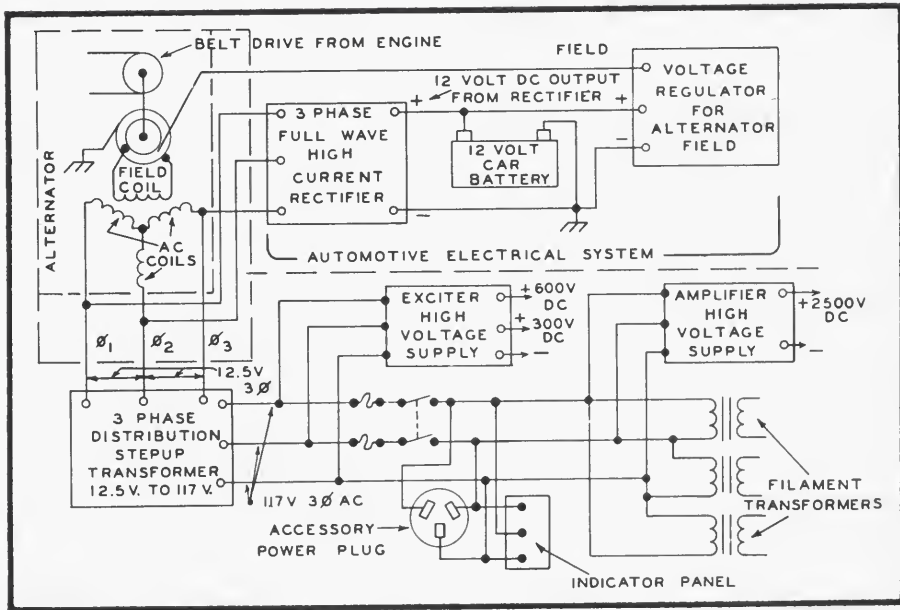

FIG. 3. DIAGRAM of the 3-phase automotive power system devised by the authors. The 3-phase 12.5-volt output from the alternator is stepped up to 117 volts with a home-made distribution transformer. Sufficient power for a full-kilowatt transmitter is available from the components specified in this article.

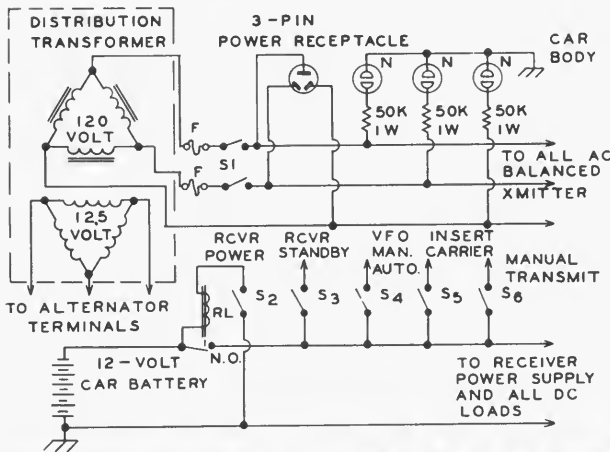

FIG. 4. CONTROL PANEL schematic diagram for the 3-phase AC electrical system. Fuses "F" and S_1 should be rated higher than the maximum current drawn from the AC circuit by the radio equipment. Switches S_2 to S_6 are SPST type taggles and energize DC relays which perform the functions indicated in the diagram.



W8DLD in the operator's seat of his high-power SSB mobile installation. Control panel is at center of dash, with voltmeters added to monitor the 12-volt DC and 117-volt AC circuits. Receiver is crystal converter into modified BC-453 Cammand Set tuner. Note hand key for CW operation just to left of steering wheel.

Up to about 300 watts of DC power can be obtained from a 3-phase high voltage supply having transformers that step up the 12-volt AC alternator output to a few hundred volts. For higher power requirements, it is desirable to first step up the 12 volts to about 120 volts AC, and then use standard transformers in the high voltage DC power supply. This concept is illustrated in the complete mobile power supply systems used by W8DLD and W8WFH, shown in the diagram of Fig. 3.

The 3-phase distribution step-up transformers used in these installations, pictured on this page, were made by the authors. Constructional details are given in a folder which is available from the *G-E HAM NEWS* office. It also is possible to use three 12-volt to 120-volt step-up transformers with primaries and secondaries in a delta connection, but the efficiency and regulation may be not as good.

An essential part of the system is the control and indicator circuit shown in Fig. 4. All three neon lamps should light with the system in operation; one lamp not glowing indicates that one of the three AC phases may be grounded to the car. The polarized 3-prong plug is handy for operating soldering irons and other accessories. Control switches S_2 to S_6 operate 12-volt DC relays to perform the required functions.

Once the alternator installation is complete and the regulator is working properly, test the regulation of the 120-volt distribution transformer with the lamp load shown in Fig. 5. Measure the voltage in each phase with the three 60-watt lamps connected; it should be about 120 volts. Then close the DPST switch; about 110 volts should be indicated. Try this test at different engine speeds. The engine idling speed should be set so that the voltage reads at least 100 volts, with the full 780-watt load.

When planning the filament and plate power supplies for the radio equipment, make sure that a load balanced to within 5 percent is presented in the 3-phase system, both at 12 and 120 volts AC. Use three filament transformers for the equipment, one across each phase, with approximately the same power drains on each.

Plate power supplies designed for a 3-phase supply usually are closely balanced. Suggested circuits for high-voltage supplies are shown in Figs. 6 through 10. Characteristics of the various circuits are shown in TABLE I. Note that 3-phase rectifier circuits — particularly the full-wave types — feature low ripple voltage, low peak inverse voltages on the rectifiers, and high output voltage.

Use whatever components are available — rectifier tubes if you have filament transformers for the circuits of Figs. 6 and 7 — or silicon rectifiers in the circuits of Figs. 8, 9 and 10. Only 4 to 6 mfd. or filter capacitance is required on power supplies for r.f. equipment; a small 4-henry choke and two

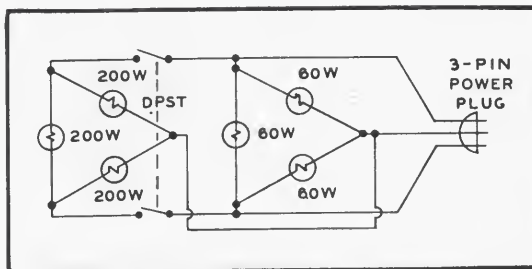
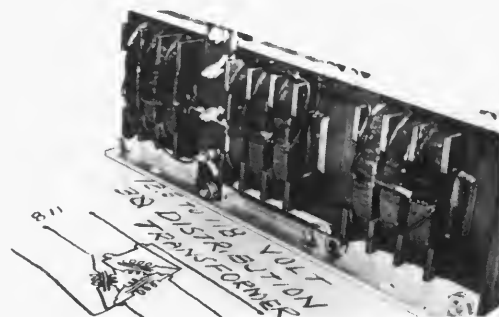

FIG. 5. CIRCUIT DIAGRAM for a 780-watt load with which the alternator may be tested after installation. Three 200-watt, and three 60-watt 117-volt lamps are used as loads across each of the three AC phases from the distribution transformer.



ENGINE COMPARTMENT VIEW of W8DLD's station wagon, showing Leece-Neville alternator in foreground and 3-phase distribution transformer mounted just ahead of it next to radiator.



DISTRIBUTION TRANSFORMER completely assembled and ready for installation. Entire transformer has been impregnated with insulating varnish to protect it from the moisture present in hot weather.

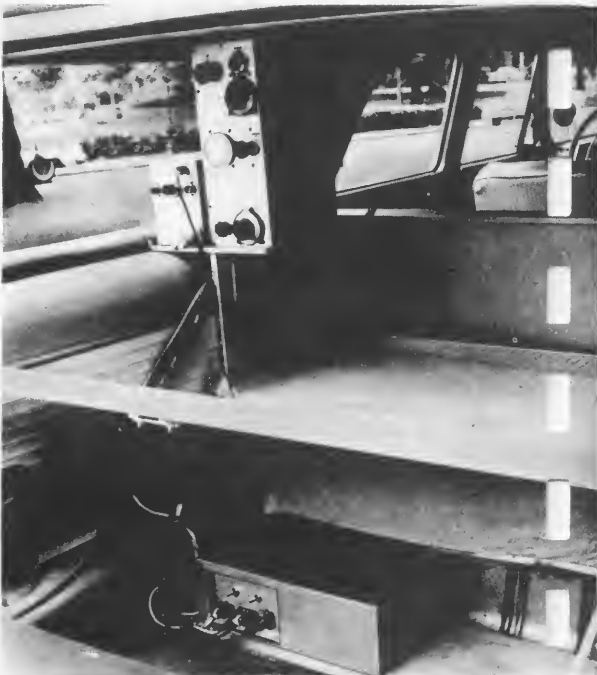

INSTALLATIONS OF POWER SUPPLIES and linear amplifiers in W8DLD's (left) and W8WFH's (right) station wagons. Storage compartments under cargo decks are handy locations for high voltage power supplies, while r.f. equipment is fastened to shelves atop rear wheel housings.

**BIBLIOGRAPHY OF ARTICLES
ON THREE-PHASE
MOBILE POWER SYSTEMS**

"A Different Approach to High-Power Mobile," by J. Emmett Jennings, W6EI; QST, April, 1953, page 28; also ARRL Mobile Manual, page 202.

"Three-Phase Power Supply for Mobile Use," by J. Emmett Jennings, W6EI; QST, January, 1958, page 28; also ARRL Mobile Manual, 2nd edition, page 183.

"Inside Leece-Neville," by D. W. Potter, W2GZD; CQ, May, 1955, page 16.

"High Power Three-Phase Mobile Power Supply," by M. Stevens, W8IWG; CQ, October, 1955, page 15.

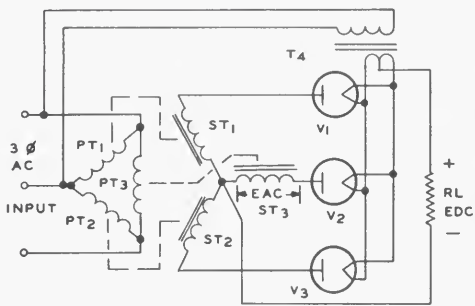

FIG. 6. 3-PHASE STAR HALF WAVE rectifier circuit for tube rectifiers. See Fig. 7 for component details.

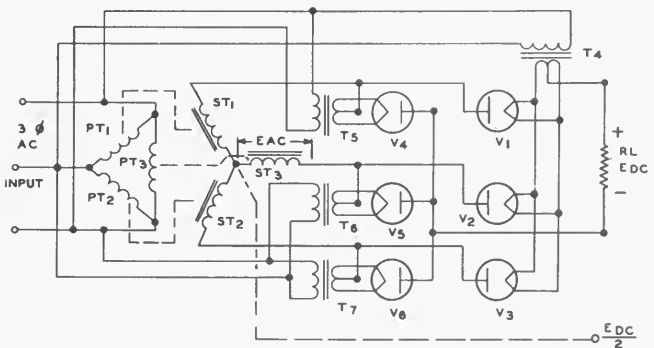

FIG. 7. 3-PHASE STAR BRIDGE full wave rectifier circuit for high vacuum (5U4-GB, 5AR4, etc.) and mercury vapor (GL-816, GL866A) rectifier tubes (V₁ to V₆). Transformers T₁, T₂ and T₃ (actually designated as "PT" and "ST" to indicate primary and secondary) are discussed in the text. Filament transformer T₄ should be rated for the current drain of three rectifier tubes; T₅, T₆ and T₇ are rated for one tube each. See TABLE I for voltage, current and peak inverse ratings.

TABLE I — 3-PHASE RECTIFIER CHARACTERISTICS

FIGURE NO.	6	7	8	9	10
AC secondary volts per 1,000 DC volts.....	855	428	855	428	740
DC volts output per 1,000 AC volts.....	1,170	2,340	1,170	2,340	1,350
Permissible DC output current above rating of single rectifier.....	300%	300%	300%	300%	300%
Peak inverse voltage per leg per 1,000 DC volts.....	2,090	1,050	2,090	1,050	1,050
Ripple frequency.....	3 f	6 f	3 f	6 f	6 f
Ripple voltage as percentage of DC output voltage.....	18%	4.2%	18%	4.2%	4.2%

(continued from page 5)

4-mfd. capacitors in a "brute force" filter are sufficient for exciter and audio equipment.

W8DLD uses the circuit of Fig. 7 with six GL-816 rectifiers and three 830-volt secondary transformers (Stancor PC-8301) in his 2,000-volt DC supply. A 300/600-volt dual output supply, using the circuit of Fig. 9, was made with three 120-to-240-volt, 50-watt step-down isolation transformers (Chicago SD-50). This powers his exciter and supplies screen voltage for a pair of GL-814 pentodes in his linear amplifier.

W8WFH uses a similar 300/600-volt power supply, plus a high voltage supply with the circuit of Fig. 9 and three 1,030-volt transformers (Stancor PC-8302) to obtain 2,500 volts DC to operate a pair of GL-4D21/4-125-A's in his linear amplifier.

Many amateurs will find the 3-phase alternator system to be the answer to their mobile power supply problems, just as W8DLD and W8WFH have found that it makes home-station results in signal reports possible from their mobile installation.

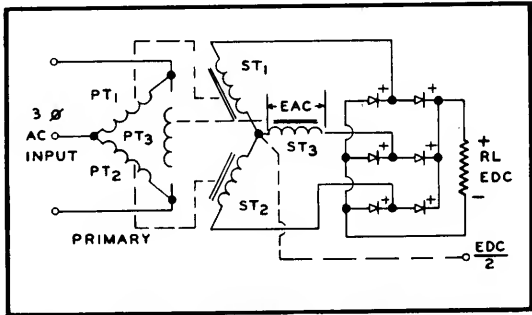

FIG. 9. 3-PHASE STAR BRIDGE rectifier circuit with silicon rectifiers. Approximately half to full DC output voltage can be obtained from the junction of the three high voltage windings, marked "EDC."

2

This half-voltage feature also can be obtained from the circuit in Fig. 7.

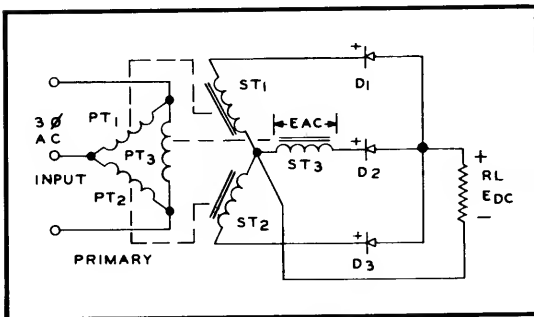

FIG. 8. 3-PHASE STAR HALF WAVE rectifier circuit with silicon rectifiers at D₁, D₂ and D₃. More than a single rectifier in each leg of the circuit will be necessary for output voltages above 200 volts. G-E type 1N1695 silicon rectifiers are suitable.

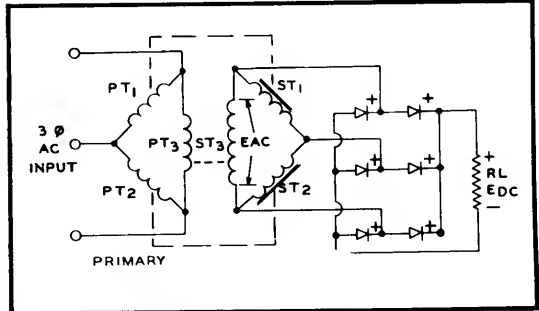

FIG. 10. 3-PHASE DELTA BRIDGE full wave rectifier circuit with silicon rectifiers. The "delta" connection of the high voltage windings reduces the DC output voltage to about 58 percent that of the star bridge circuit in Fig. 9, using the same transformers.

Added Information on Three-Phase AC Mobile Power Supply Systems

CONSTRUCTION DETAILS FOR 3-PHASE DISTRIBUTION STEPUP TRANSFORMER

An excellent, efficient 3-phase distribution transformer which will step up the 12-volt 3-phase AC output from automotive alternators to 120 volts AC can be constructed using home workshop facilities. This transformer has been designed to use three sets of identical standard "E" and "I" shaped laminations. The iron should preferably be of audio transformer quality for highest efficiency over the wide frequency range of 60 to 1000 cycles delivered by the alternator at various engine speeds.

The unusual design of the windings in "pies" was chosen for high efficiency over the wide frequency range which must be covered. Design data will not be given here, but is based on sound principles. Results achieved in several completed transformers verify the efficiency of this design.

Actually, three separate identical transformers are constructed, and then connected together physically with strips of angle stock, as shown in Fig. 1. The three primaries, and the three secondaries, are connected in a "Delta" circuit, as shown in this view.

FIGURE NO. 1.

COMPLETED TRANSFORMER WITH WINDINGS IMPREGNATED IN INSULATING VARNISH, READY FOR INSTALLATION IN VEHICLE.

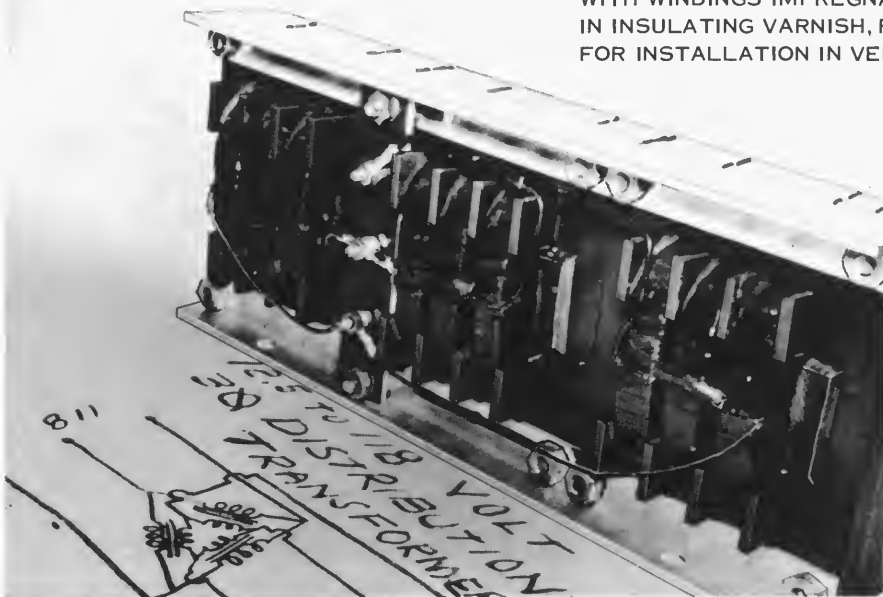

Figure No. 2 shows the winding mandrel. This one is made of brass, but could be made from plywood for the end pieces and clear maple for the split block. The core size will determine the exact size of this mandrel. This photo also shows one primary winding between two secondary windings. This is the way they look when taken off the mandrel. The three heavy wires out each side of the primary winding will later be cleaned and connected together. Obviously the secondary consists of two equal pies.

In Figure No. 3, the heavy wires on the primary have been connected and the windings wound with 1/2-inch wide varnished cambric tape. The core used is a 1-5/8 x 1-1/2 inch stack of good quality transformer iron. The wood spacers also show in the picture.

Note in Figure No. 4 that the primary has had connectors put on the heavy paralleled leads and the core has been assembled. Three of these transformers are then made into one unit with aluminum angle and 1/4-inch x 20 brass bolts. Also, the windings are connected in three phase delta as shown in Figure No. 1. The one foot long rule on top of the transformers shows the size.



FIGURE NO. 2. VIEW OF WINDING MANDREL AND ONE SET OF COMPLETED COILS.

Material necessary:

1. Three identical transformer cores with "E" and "I" type laminations. Core area should be at least $2\frac{1}{4}$ - square inches; this means a cross section of at least $1\frac{1}{2} \times 1\frac{1}{2}$ inches. The core described measured $1\frac{5}{8} \times 1\frac{1}{2}$ inches. Obviously the winding information is for this size core, but can be easily adapted to another size through simple arithmetic.
2. Two pounds of No. 14 Formex (type HF) magnet wire for primaries (three windings necessary). Four pounds of No. 16 Formex (type HF) magnet wire for secondary windings (six windings necessary).
3. 24 wood spacers (soft white pine) $\frac{1}{8} \times \frac{5}{8} \times 3\frac{1}{8}$ inches.
4. 6 wood spacers (soft white pine) $\frac{1}{8} \times 1\frac{1}{2} \times 3\frac{1}{8}$ inches.
5. One 4-inch diameter roll of $\frac{1}{2}$ -inch wide varnished cambric tape.
6. 36 feet of good lacing twine (Used to tie windings before removing from mandrel).
7. 1 Gal. No. 1201 GE red glyptal paint (or equivalent good insulating varnish).
8. 4 pieces aluminum angle to mount three transformers in a frame. My unit takes $12\frac{1}{4}$ inches long by $\frac{3}{4} \times \frac{3}{4} \times \frac{1}{8}$ inches in cross section.
9. 10 BRASS bolts and nuts $2 \times \frac{1}{4} \times 20$ inches.
 2 BRASS bolts and nuts $2\frac{1}{2} \times \frac{1}{4} \times 20$ inches (extra length to mount terminal strip).
10. Terminal strip for 3-phase 120 volt connections, $\frac{3}{4} \times 1 \times \frac{1}{8}$ inches (GE textolite, or other insulating board).
11. 3 - 8×32 brass bolts, lock washers and six nuts to complete terminal strip.



FIGURE NO. 3. VIEW SHOWING THE THREE SETS OF HEAVY WIRES FROM THE 12.6-VOLT PRIMARIES CONNECTED. SECONDARY LEADS SHOW AT TOP.

No terminal strip is necessary for primary of transformer. Connect three #8 flexible GE flannel wire leads permanently to connect transformer to alternator.

Primary (12.6 volt) 19 turns No. 14 Formex wire. Winding consists of 3 separate wires that are parallel connected after winding is complete. (Tied with string, dipped in 1201 red Glyptal, and taped with varnished cambric). Due to low voltage (12.6 volt) no insulation is used between layers or windings. Wind on first 19 turns, then second 19 turns, then third 19 turns. This completes winding. Try to keep each winding smooth so turns do not pile up or there will not be enough room to get third winding on mandrel.

Secondary: (120 volt) 94 turns No. 16 Formex wire. Wind on two 60 volt windings connected in series. Each half of the secondary has 94 turns or the total primary has 188 turns. Try to keep a smooth winding, layer by layer, or there will be trouble in getting the 94 turns on the mandrel. No insulation is used because the voltage (60 volts) is low and the 1201 red Glyptal and HF type wire give adequate insulation.

The finished transformer can be connected to 115 volt 60 cycle and allowed to run until temperature rises to 180 degrees F. and then given a final dip in 1201 Glyptal. Unless the 12.6 volt primary is loaded, it will take a couple of hours to get the transformer hot running from 115 volt 60 cycle power. Remember it is designed for a minimum of 100 cycles so will eventually get hot running on 60 cycles. You may prefer to heat the transformer in an oven if available.

This transformer bank must be mounted near the alternator. It will probably get wet. Do a good job on the dipping and insulation and you can forget it indefinitely.

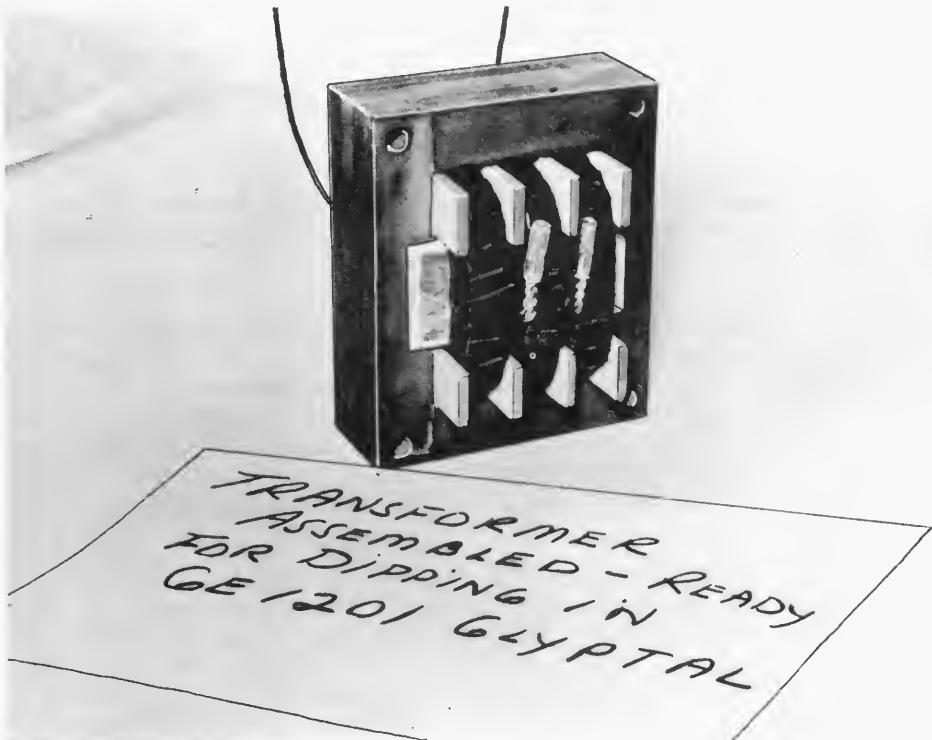

FIGURE NO. 4. ONE SECTION OF THE TRANSFORMER ASSEMBLED, READY FOR FINAL DIP IN INSULATING PAINT OR VARNISH.

It is also possible to use this same transformer design to wind a 3-phase transformer with higher voltage secondaries, rather than the 120-volt secondaries described here. Windings which will deliver several hundred volts can be substituted, thus making it possible to step up the 12-volt alternator output directly to high voltage. When the three transformer secondaries are connected in a 3-phase star fashion to a suitable rectifier, as shown in Figures 7 and 9 on pages 6 and 7 of the July-August, 1960 issue, the DC output voltage from the rectifier will be 2.34 times the voltage across one secondary winding.

For example, if 1,000 volts DC are required, each secondary may be wound to deliver 430 volts AC. Based on the 120-volt winding having two 94-turn coils, a 430 volt winding would have two coils of 340 turns each, or a total of 680 turns on each secondary. This wire size would be smaller, of course, since the output current requirements would be much lower than that of the 120-volt windings. Wire sizes from No. 20 to No. 24 would be chosen. Additional insulation would have to be used around the secondary, because of the higher voltages present.

HINTS AND KINKS

Before mounting anything in the car, get the alternator installed and tested. Complete installation kits are available for most cars. If one is not made for your car - trade the car! Once the alternator installation is complete and the regulator is working properly, holding the battery at 13.5 to 14.00 terminal volts, install the distribution transformer. Connect the primary solidly to the alternator terminals. Do not use fuses or a relay switch in this high current low voltage circuit. The alternator is belt driven so the protection is there if a direct short circuit happens.

Test the transformer regulation in this manner: Get six porcelain lamp sockets, a double pole single throw knife switch, three 60 watt lamps and three 200 watt lamps. Connect as shown in Figure No. 5 on page 5 of the July-August issue. The three 60 watt lamps present a balanced 180 watt load to the alternator. They represent the small load required by your equipment in the "stand-by" condition. Measure the voltage. It should be approximately 120 volts per phase.

Now close the switch and throw on the 600 watt load. Read the voltage. It should be at least 110 volts. This represents a "voice peak" when the transmitter is drawing full load. Try this test at different engine speeds. The carburetor idle adjustment must be set so the voltage will not fall below 100 volts at slowest speed. You may not like this with an automatic transmission but most cars creep a little anyway so yours will creep a bit more. This adjustment is made at full load of 780 watts. (600 180). I refer to the 100 volt idling limit. 110 volts should be just a few RPM's faster.

Summarizing the installation and operation of 3-phase AC power systems in automobiles for more efficient operation of mobile radio equipment, remember the following points:

1. The alternator manufacturer, such as Leece-Neville, puts a rating on the complete system he sells. You buy a 50-ampere, 12 volt system or 100 ampere, 6 volt system. On the surface this looks like the alternator is capable of supplying 600 watts at the battery terminals by way of a rectifier. This is all true. What is left out is that the rectifier carries an exact maximum current limit. It is responsible for the 600 watt limitation. The alternator is capable of delivering much more power. Years of field use indicate the rating of the alternator alone to be well above one KVA. This is under summer 85 degree F. temperature with the normal cooling in a car in motion.
2. Idling speed of an alternator in ordinary car usage is 100 or more cycles. Maximum frequency may go as high as 1000 cycles.
3. Three phase full wave rectification has only 5% ripple before filtering. Ripple frequency from a 3 phase full wave rectifier is six times the AC supply frequency.
4. Filtering a 3 phase full wave DC power supply is extremely easy because the ripple is always 6 times the AC cycle input frequency. (See statement #3) A condenser of 2 to 6 MF is usually adequate when supplying an RF stage. For audio stages a small 4 Henry choke is desirable along with two 4MF condensers in a 'brute force' filter.
5. Modern 115 volt 60 cycle transformers work well on 100 to 1000 cycles. Ratings can be exceeded considerably using a minimum of 100 cycles on a 60 cycle transformer design.

Heavy duty filament transformers can be used as step up transformers for high voltage power supplies operated directly from the output of a 12-volt, 3-phase alternator without the distribution transformer described in this bulletin. Simply take three 6.3-volt filament transformers and connect these windings in delta across the alternator supply. Then, each 115-volt secondary can be fed into a star bridge rectifier circuit, as shown on page 7 of the July-August, 1960 issue. The DC output voltage will be 2.34 times the 230-volt output of one secondary, or about 700 volts. Or, doubler type rectifier circuits could be used to obtain 1,000 to 1,400 volts DC.

Added Uses for Mobile Alternators . . .

The 3-phase AC alternator system described in the July-August, 1960 issue is a good source of emergency power, according to W8DLN. As long as the load on the alternator is closely balanced, a kilowatt of power is available for lighting, running appliances, and even AC-powered communication equip-

ment in an emergency. For the latter application, it is best to hold the engine speed below 1,000 r.p.m. so that the alternator frequency does not go above 200 cycles. Transformers in some equipment designed for 60-cycle operation may not operate efficiently on frequencies above this.

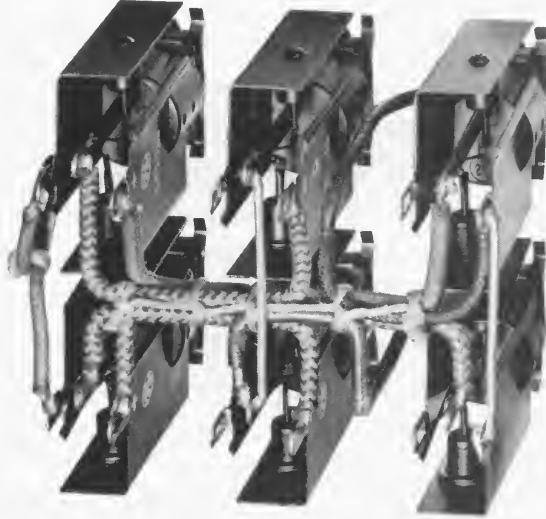

ABOVE — Top view of six G-E type 1N1016 two-section germanium TV rectifiers, assembled into bridge rectifier unit which will handle up to 750 Volts AC at 400 milliamperes DC output current.

BELOW — Bottom view of typical dual voltage power supply of the type described on pages VIII-10 to VIII-15.

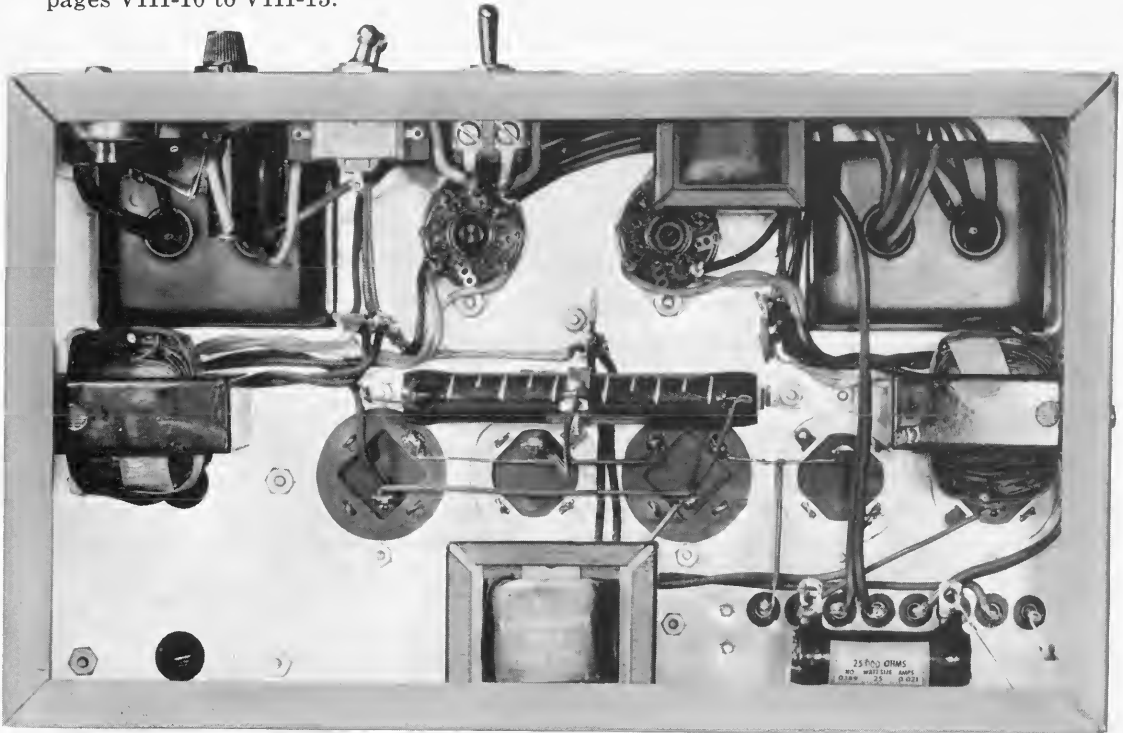

TRANSMITTING TUBE TESTING AND OPERATING HINTS

SIMPLIFIED TEST PROCEDURES FOR POPULAR TRANSMITTING TUBES

From May-June, 1951

TEST INSTRUCTIONS FOR:

GL-2E26	GL-810
GL-4D21/4-125A	GL-811A
GL-4-250A/5D22	GL-812A
GL-35T	GL-813
GL-100TH	GL-814
GL-203A	GL-815
GL-211	GL-829B
GL-592	GL-832A
GL-805	GL-837
GL-806	GL-838
GL-807	GL-8000

GL-8005

Whenever you suspect that a receiving tube is bad, you either plug in a new one (if you have a spare) or you make a trip to see your serviceman friend and use his tube tester. However, when something has gone wrong in your transmitter, you hesitate to try your spare transmitting tube in place of the suspect tube, and you certainly will not find a transmitting tube tester handy.

Or, if the ham in the next block wants to trade some tubes with you, you may end up with some low emission tubes that are good only for future trading with another unsuspecting ham.

All of the above points out the fact that it would be extremely nice to be able to test a transmitting tube when the need arises. It is the purpose of this article to explain how to run some simple (hence non-conclusive) tests on your favorite bottle.

GENERAL TESTING COMMENTS

Vacuum tube manufacturers spend a great deal of time and money in order to test their product completely. A transmitting tube such as the GL-813, for example, may have to pass twenty or more tests before it is considered good enough to bear the G-E trade-

mark. Many of the individual test sets used to run these tests will each be worth more than an elaborate ham transmitter.

Obviously, therefore, any simple tests which the amateur is able to run will not do as complete a job of quality testing as the tests the manufacturers make. However, the simple tests about to be described will permit the ham to roughly evaluate the quality of his transmitting tubes, and in most cases, these simple tests will give a true indication of whether the tube is generally good or generally bad.

It is possible for these simple tests to call a bad tube good, and a good tube bad, especially if the tests are not carefully conducted, but these cases will be the exception, so the following simple tests should give you a wealth of information about the quality of your transmitting tubes.

TUBE TYPES CONSIDERED

Testing instructions are given for most of the popular and widely used amateur tubes (see list above). If a certain type is not included, it is either because the testing would be more complicated and

involve special apparatus; or, it is a high-power type not deemed necessary to include.

TEST INSTRUCTIONS

Three different tests are suggested for each tube type. The first is a short and continuity test, the second a static characteristic test, and the third either an oscillation test or a limited peak emission test, depending on tube type. It will be necessary to run all three tests in order to completely test any particular tube.

Run the tests in order. If a tube fails Test I because of an internal short, there is no point in making any further tests. However, if a tube passes Test I and fails Test II, you could still run Test III to see if the tube has any emission, even though Test II showed you that the static characteristic of the tube was poor.

If the tests are to mean anything, you must run them carefully. Use accurate meters. Follow the instructions exactly.

For tests II and III, allow the filament to heat for five minutes before proceeding with the test.

TEST I

The data for Test I is given on page 3. The purpose of this test is to determine filament continuity and to check for undesirable shorts. The base connection diagram for each tube is shown. These diagrams are made looking at the bottom of the tube, with the base pins facing you.

Use an ohmmeter to check continuity. *Do not* use a lamp in series with the a-c line as a continuity indicator, as you may damage the filament of the tube. An ohmmeter with a range of zero to 50,000 ohms or zero to 250,000 ohms, or anything in that range will be satisfactory. It is not advisable to use an ohmmeter scale which will read too high a resistance, such as ten megohms or so, because you are looking for continuity and shorts, and not for leakage.

Check for filament continuity first, then check for shorts by probing between a given pin and all other pins, then another pin against all other pins, etc. If a pin is marked NC, for no connection, check it anyway to make certain no continuity exists. All electrodes, including grid and anode caps (if any), should be tested for continuity or shorts.

Consider a tube to have passed this test if you have filament continuity, and continuity between other electrodes as shown on the diagram—and, if all other electrodes are floating, that is, have no continuity to any other electrodes.

TEST II

The data for this test is given on page 4. The purpose of this test is to determine, approximately, the static characteristic of the tube in question. In other words, it is a check on the controlling ability of the grid (or grids). This test is intended to show up a grid that has been bent out of place due to dropping a tube, for example. Many other small internal faults may also be determined. This test *does not* show whether a tube has low emission, or is near the end of life.

All tubes are not tested in the same manner. One group (Test II-A) must have the grid bias adjusted until the plate current measures a predetermined value, then the grid bias voltage must be read to determine if it falls in the "good" range. The other group (Test II-B) must have the grid bias voltage set to a certain value, then the resultant plate current must fall within a certain "good" range.

The circuit diagram for the test set-up is shown in Fig. 1 on page 4. If the tube you are testing has no

cathode, disregard the cathode connection shown. Similarly, if the tube is a triode, disregard the dotted screen-grid lead. (One tube, the GL-837, requires a suppressor voltage. See note B on page 4.)

It is not necessary to construct a separate test set for Test II. You may use a socket in a rig you already have. Just remove, temporarily, the grid, screen grid and plate leads, and connect as shown in Fig. 1. It is desirable to be able to vary the filament voltage, so that it may be set exactly at the voltage specified in column 1, page 4.

To test a tube in the II-A group, apply filament voltage, apply a grid bias which is midway in the specified range, then apply plate voltage (and screen voltage if the tube is not a triode). Check the plate current and readjust grid bias until the plate current is as specified, then read the grid bias voltage you are using. The tube is "good" if the grid bias voltage is within the limits shown.

To test a tube in the II-B group, apply filament voltage, apply the exact grid bias voltage shown, and apply plate (and screen) voltage. Read plate current. The tube is "good" if the plate current is within the limits shown.

TEST III

The data for Test III-A is given on page 5, and that for Test III-B is given on page 6. Seventeen tubes are listed for the former test, and six tubes are more easily tested by the latter test. Test III-A is a power oscillation test, in which the tube is operating at 14 megacycles. Test III-B is a test which checks for the total emission, under the conditions shown, for a very brief moment.

The diagram on page 5 shows the test set-up necessary for Test III-A. This is a Hartley oscillator circuit. Because this test is run at a reduced filament voltage, it is absolutely necessary that a variable control be used in the filament circuit. This control need not be an autotransformer, as shown, but some sort of stepless control is needed.

In the circuit diagram for this test, the 0.005 mf condensers must have a voltage rating consistent with the tube being tested. They should be capable of handling the d-c plate voltage (E_B) plus some safety factor. The 0.005 mf condenser in the screen circuit should handle the d-c screen voltage (E_S), plus a safety factor. The two 0.002 mf condensers should be rated at 400 or 600 volts breakdown.

The tank coil should have an inductance of approximately 5 microhenrys. A regular 20 meter transmitting coil will serve, as long as the wire in the coil is bare, so that the proper point for the tap can be located.

If you already have a transmitter using the tube in question, it is not necessary to provide an oscillator circuit, as you may use the tube as an amplifier and run the test. In this case the tube must be run at as high a plate (and screen) voltage as specified, else the results will only be valid for the lower voltage you use.

To run Test III-A, put the tube in the circuit as shown, and turn on the filament, setting the control to give normal voltage. Make certain a dummy load is coupled to the tank, and apply plate (and screen) voltage. If the control grid current (I_C) is not as specified, adjust the tap on the coil (*with power off*) until the grid current is as specified.

Adjust the dummy load coupling (see *Ham News*, Vol. 6, No. 1, page 6 for a discussion of dummy loads), until the proper plate current (I_B) is being drawn, according to the table. Readjust the tap for proper grid current. Next, measure power output in some manner, and reduce the filament voltage until the power output drops down 10%. Read filament voltage. If this voltage is below the figure stated in

column 7 on page 5, the tube is "good." If the voltage is more than the stated figure, the tube is "bad."

(Power output may be read in a comparative manner by the device shown on page 8.)

If a tube passes Test III-A, you know that the tube has some life left in it. The lower the filament voltage reading, the better the emission. This test will permit you to compare the emission of two tubes quite easily.

If you use your transmitter for the test set, Test III-A is run in a similar manner. Turn on the filaments, wait five minutes, then apply grid drive until I_C is as specified. Apply plate (and screen) voltage and adjust your dummy load until I_B is as specified. Measure power output, lower filament voltage until this power drops to 90% of the original value, then read filament voltage.

When running test III-A, watch the tube envelope. If a bluish glow appears which seems to fill most of the envelope, the tube is gassy and hence "bad." Under these circumstances, plate and screen currents may run extremely high.

Test III-B is a different sort of test, but it gives

you approximately the same information as Test III-A. In Test III-B all electrodes except cathode (and/or filament) are connected together, then a positive voltage is applied to the electrodes, and the total current measured. Caution must be employed when running this test, as the grid will be damaged if the voltage is applied for more than a second or so.

To run this test, connect the tube as shown in Fig. 3. Apply the filament voltage specified in column 1, page 6, and allow the filament to heat for five minutes. Make certain you are using the right plate voltage (column 2, page 6) then throw the switch. The instant the plate current meter settles down, make a mental note of the reading and turn the switch off. *Under no circumstances should the plate voltage be applied for more than four seconds.*

If the current for a new tube is greater than the value indicated in column 4, page 6, then the tube is "good." If the current for a used tube is greater than the value specified in column 3, page 6, then the used tube is "good." If I_T is below this last figure, the tube is "bad." Tubes which have total currents (I_T) which are approximately the same value have approximately the same emission.

TEST I Continuity and Short Test

INSTRUCTIONS:

Use ohmmeter as discussed previously. Refer to proper diagram, below, and check for filament continuity, including filament or heater center-taps (if any). Check between other points where continuity should exist. Check the remainder of the pins, each to all others, to see if a short exists. Reject tube if undesired shorts exist or if continuity is not found where it should exist.

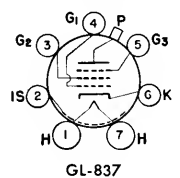
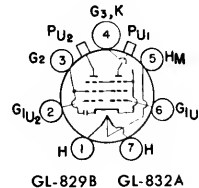
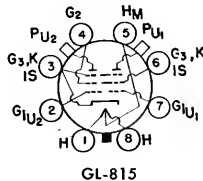
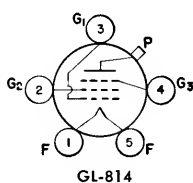
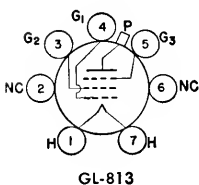
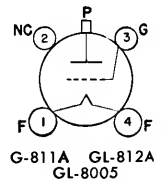
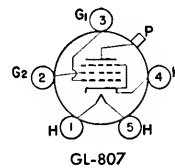
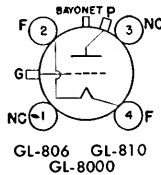
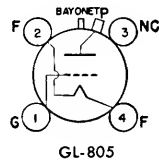
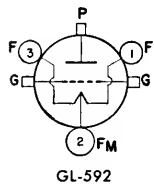
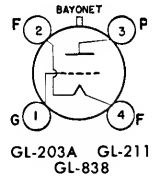
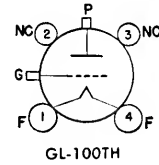
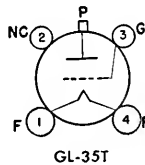
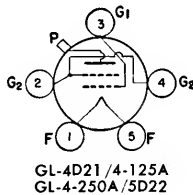
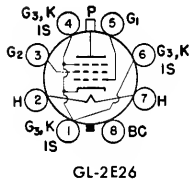

KEY:

Bc—Base Sleeve; F—Filament; Fm—Filament center-tap; G—Grid; H—Heater; Hm—Heater center-tap; Is—Internal Shield; K—Cathode; NC—No connection; P—Plate; S—Shell; U—Unit.

TEST II Static Characteristic Test

IIA

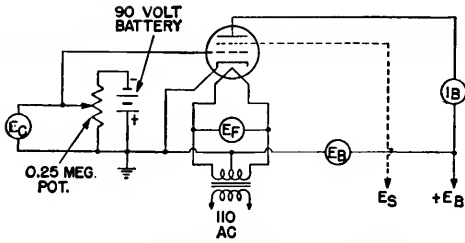

Fig. 1. Circuit diagram for static characteristic test set.

INSTRUCTIONS:

Apply filament voltage as shown in column 1; wait five minutes. Adjust grid bias to value half-way between those shown in column 4. Apply E_B and E_S . Readjust grid bias until I_B value is as shown in column 3. Read value of E_C on meter. Tube is "good" if this voltage falls inside the range indicated in column 4.

Column Number	1	2	3	4	5	6
Tube Type	E_F a-c volts	E_B d-c volts	I_B d-c ma.	$-E_C$ d-c volts	E_S d-c volts	Notes
GL-2E26	6.3	300	30	15/25	160	
GL-4D21/4-125A	5.0	1500	50	35/65	350	
GL-4-250A/5D22	5.0	2500	70	65/90	500	
GL-35T	5.0	1000	35	0/20	...	
GL-100TH	5.0	2000	40	20/50	...	
GL-806	5.0	1500	100	50/80	...	
GL-807	6.3	500	50	15/25	250	
GL-812A	6.3	1000	50	10/20	...	
GL-815	6.3	400	20	20/35	200	A
GL-829B	6.3	400	40	10/20	200	A
GL-832A	6.3	400	20	25/40	250	
GL-8005	10.0	1000	50	20/40	...	

IIB

INSTRUCTIONS:

Apply filament voltage as shown in column 1; wait five minutes. Set grid bias to value given in column 4, and apply E_B and E_S . Read I_B . Tube is "good" if this current falls inside the range of values indicated in column 3.

Column Number	1	2	3	4	5	6
Tube Type	E_F a-c volts	E_B d-c volts	I_B d-c ma.	$-E_C$ d-c volts	E_S d-c volts	Notes
GL-203A	10.0	1000	85/155	0	...	
GL-211	10.0	1000	55/85	50	...	
GL-592	10.0	2000	40/60	50	...	
GL-805	10.0	1500	60/100	0	...	
GL-810	10.0	2000	45/65	35	...	
GL-811A	6.3	1600	0/30	0	...	
GL-813	10.0	2000	35/65	35	400	
GL-814	10.0	1250	30/48	20	300	
GL-837	12.6	350	0/30	20	200	B
GL-838	10.0	1250	40/70	0	...	
GL-8000	10.0	2000	40/75	90	...	

NOTES:

- A. For one section only. The grid of the section not being tested should be connected to the negative terminal of a 90-volt battery, and the positive battery terminal connected to the common cathode.
- B. This tube requires a suppressor voltage during test. Connect +45 volts to the suppressor grid (pin 5). The negative voltage return goes to cathode (pin 6).

TEST IIIA 14 Megacycle Power Oscillation Test

INSTRUCTIONS:

Apply filament voltage as shown in Column 1. Wait five minutes. Apply plate and screen voltage (be sure dummy load is in place). If grid current is not as specified in column B, change tap on coil until value is correct. Change output coupling till plate current is as shown in column 5. Recheck grid current. Reduce filament voltage until output drops 10%. Read filament voltage. Tube is "good" if filament voltage is equal to or less than value shown in column 7.

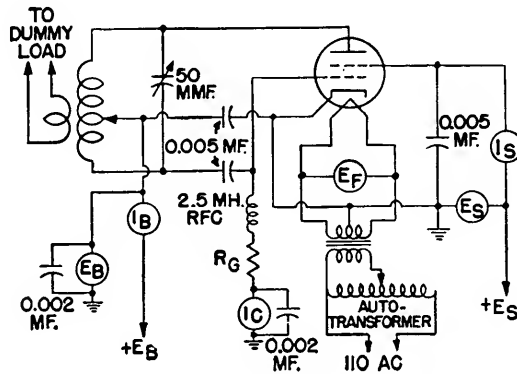

Fig. 2. Circuit diagram for power oscillator test set.

Column Number	1	2	3	4	5	6	7	8
Tube Type	E_F a-c volts	R_G ohms	I_C d-c ma.	E_B d-c volts	I_B d-c ma.	E_S d-c volts	E_M o-c volts	Notes
GL-4D21 /4-125A	5.0	15,000	10	3000	100	350	4.5	
GL-4-250A/5D22	5.0	15,000	8	3000	200	500	4.5	
GL-35T	5.0	3,000	40	1500	120	...	4.5	
GL-100TH	5.0	4,000	50	3000	150	...	4.5	
GL-203A	10.0	5,000	25	1250	175	...	9.0	
GL-211	10.0	5,000	30	1250	175	...	9.0	
GL-592	10.0	5,000	45	3000	200	...	9.0	
GL-805	10.0	5,000	57	1500	210	...	9.0	
GL-806	5.0	10,000	50	3000	200	...	4.5	
GL-810	10.0	5,000	50	2000	250	...	8.8	
GL-811A	6.3	3,500	40	1500	150	...	5.7	
GL-812A	6.3	3,500	40	1500	150	...	5.7	
GL-813	10.0	10,000	12	2000	180	400	9.0	C
GL-814	10.0	8,000	12	1250	150	300	9.0	D
GL-838	10.0	5,000	55	1250	175	...	9.0	
GL-8000	10.0	8,000	38	2250	275	...	8.8	
GL-8005	10.0	5,000	35	1500	200	...	9.0	

NOTES: C. Screen current on "good" tube should be between 25 and 55 ma.
D. Screen current on "good" tube should be between 15 and 30 ma.

Test IIIB Limited Peak Emission Test

INSTRUCTIONS:

Apply filament voltage as shown in column 1. Wait five minutes. Use battery indicated in column 2 for anode supply. Turn switch on and as soon as meter in anode circuit comes to rest, make a mental note of I_T and turn switch off. If switch is on for more than four seconds you may damage the tube. A new tube is "good" if I_T is greater than the value indicated in column 4. A used tube still has some life left if I_T is greater than the value shown in column 3 indicates a usable tube.

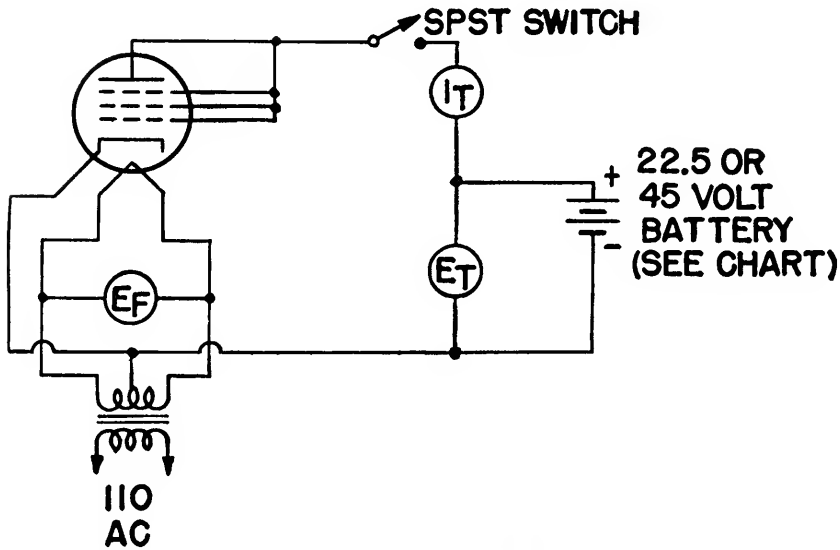

Fig. 3. Circuit diagram for limited peak emission test.

Column Number	1	2	3	4	5
Tube Type	E_F a-c volts	E_T d-c volts	I_T d-c ma.	I_T d-c ma.	Notes
GL-2E26	6.3	22.5	85	110	
GL-807	6.3	45.0	190	255	
GL-815	6.3	22.5	85	110	E
GL-829B	6.3	22.5	160	215	E
GL-832A	6.3	22.5	50	70	E
GL-837	12.6	22.5	65	85	

NOTES:

E. For one section only. The grid of the section not being tested should be connected to the negative terminal of a 90-volt battery, and the positive battery terminal connected to the common cathode.

R-F POWER INDICATOR

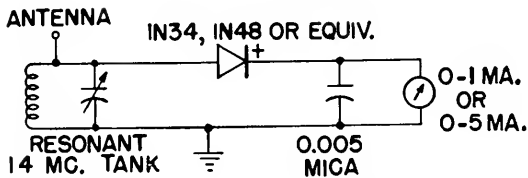

Fig. 4.
Circuit diagram for germanium diode r-f power indicator.
 This unit is used in conjunction with Test III-A.

Fig. 4 gives the circuit diagram for a simple power output indicator to be used in conjunction with Test III-A. It consists of a tank circuit, a germanium diode, and a d-c milliammeter. As shown, this instrument will not give a quantitative power reading, but it will read percentage changes in power, which is all that is required for Test III-A.

The inductance and capacitance in the tank circuit

TRANSMITTING TUBE TESTING--ADDITIONAL DATA

Many transmitting and special purpose tubes, not in existence when the original article appeared in G-E HAM NEWS, can be tested by the same procedures. In most cases, the technical data appearing in sheets published by the tube manufacturer, or in the Tube Data Section of the ARRL HANDBOOK, provides the necessary operating conditions required for tests I, II, IIIA, and IIIB. Suggestions for choosing pertinent data figures follow:

TEST I - Continuity and Short Test (Page 3).

Follow procedure as outlined, using connection diagram for tube being tested.

TEST II - Static Characteristic Test (page 4.).

1. Select proper heater voltage.
2. Apply one-half maximum rated DC plate voltage.
3. Apply one-half maximum rated DC plate current.
4. Vary negative DC bias from 25 to 45 percent of value given in technical

data for class C telegraphy operation at maximum rated plate voltage.

5. Apply rated screen voltage for class C telegraphy operation.

TEST IIIA - 14-Megacycle Power Oscillation Test (page 5).

1. Use circuit constants, and apply voltages and currents listed on data sheet for class C plate modulated service.
2. Tube can be considered serviceable if filament voltage can be reduced 10 percent or more before power output drops 10 percent.

TEST IIIB- Limited Peak Emission Test

1. Exact figures are not available for tubes other than those listed on page 6 of that issue. However, when about 30 volts DC is applied to most small and medium power transmitting tubes in the circuit of Fig. 3, approximately twice the normal maximum rated plate current should be observed on the milliammeter.

Additional Data -- 14 Megacycle Power Oscillation Test for Transmitting Tubes

Not Listed in G-E HAM NEWS, May-June, 1951 (Vol. 6, No. 3)

Test IIIA Table, Page 5

Col. No.	1 E_f	2 R_G	3 I_c	4 E_b	5 I_b	6 E_s	7 E_m
Tube Type	AC Volts	Oams	DC ma	DC Volts	DC ma	DC Volts	AC Volts
4X150A	6.0	9,000	10	1250	200	250	5.2
4CX300A	6.0	3,500	25	2000	250	250	5.2
4-400A	5.0	15,000	8	3000	200	500	4.5
4-1000A	7.5	6,500	30	5,500	600	500	6.7
250-TH	5.0	10,000	50	3,000	200	---	4.5

What about new information on Sideband?

The next edition of this book will cover subsequent articles published in *G-E HAM NEWS* from 1961 to the publication date of the revised edition, along with any other material on sideband that is timely.