



VXR-5000

Commercial-Grade VHF Repeater

YAESU MUSEN CO., LTD.

1-20-2 Shimomaruko, Ota-Ku, Tokyo, 146, Japan

YAESU U.S.A.

17210 Edwards Rd., Cerritos, CA 90703, U.S.A.

YAESU INTERNATIONAL SALES, (Caribbean, Central & So. America)

7270 NW 12th St., Suite 320, Miami, FL 33126, U.S.A.

YAESU EUROPE B.V.

Snipweg 3, 1118DN Schiphol, The Netherlands

YAESU UK LTD.

Unit 2, Maple Grove Business Centre,
Lawrence Rd., Hounslow, Middlesex, TW4 6DR, U.K.

YAESU GERMANY GmbH

Am Kronberger Hang 2, D-65824 Schwalbach, Germany

YAESU HK LTD.

11th Floor Tsim Sha Tsui Centre, 66 Mody Rd.,
Tsim Sha Tsui East, Kowloon, Hong Kong

Contents

Introduction	1-1
Repeater Version Type Identification	1-2
Specifications	1-3
Accessories & Options	1-4
Rear Panel Controls & Connectors	1-5
CNTL-1 Unit Status LEDs	1-6
Installation	1-7
Changing Power Transformer AC Mains Wiring	1-8
Repeater Mounting & Installation	1-9
Rack Mount	1-9
Wall Mount	1-9
VTS-100 VX-TRUNK Interconnection	1-11
VXR-5000 Accessory Connector	1-12
VXR-5000 Line Interface Port	1-15
Cover Removal and Unit Access	1-16
Circuit Description	2-1
EEPROM Programming Instructions	3-1
Alignment	4-1
Chip Component Description	5-1
Block Diagram & Connection Diagram	6-1
PCB Diagram & Parts List	
Control (CNTL) Unit 1	7A-1
Control (CNTL) Unit 2	7B-1
TX Unit	7C-1
RX Unit	7D-1
TX VCO Unit	7E-1
RX VCO Unit	7F-1
PA Unit	7G-1
REG Unit	7H-1
D SUB Unit	7I-1
MOD JACK Unit	7J-1
CAPA Unit	7K-1
Mechanical Details and Exploded View	8-1

Introduction



This manual provides technical information necessary for servicing the VXR-5000 FM Land Mobile Repeater. A reprint of the CE-8 channel-programming software manual is also included for easy reference.

Servicing this equipment requires expertise in handling surface-mount chip components. Attempts by non-qualified persons to service this equipment may result in permanent damage not covered by the warranty, and may be illegal in some countries.

Two PCB layout diagrams are provided for each double-sided circuit board in the repeater. Each side of the board is referred to by

the type of the majority of components installed on that side ("leaded" or "chip-only"). In most cases one side has only chip components, and the other has either a mixture of both chip and leaded components (trimmers, coils, electrolytic capacitors, ICs, etc.), or leaded components only.

While we believe the technical information in this manual to be correct, Yaesu Musen assumes no liability for damage that may occur as a result of typographical or other errors that may be present. Your cooperation in pointing out any inconsistencies in the technical information would be appreciated.

Repeater Version Identification

The VXR-5000 version can be determined from the identification label located on the rear panel. From the production code on the identification label, use the table below to determine the various hardware, options and operational features for which the repeater is configured, based on the example at the bottom of the table.

VXR-5000 Production Codes

Frequency Range	
13	134 - 147 MHz version A
14	146 - 160 MHz version B
15	156 - 168 MHz version BS-1
16	164 - 175 MHz version C
40	400 - 420 MHz version A
43	430 - 450 MHz version C
45	450 - 470 MHz version D
47	470 - 490 MHz version E
49	490 - 512 MHz version F
Channel Separation	
E	12.5 kHz
G	20 kHz
H	25 / 30 kHz
Power Output	
25	25 Watts RF Output
Not Used	
9	This digit not used (placeholder)
Control Units	
J	Standard Type
Options	
0	w / o Options
1	FTS-22 CTCSS Encoder/Decoder
AC Mains Voltage/AC Plug	
B	117 VAC 2P USA Plug w/o ground
C	117 VAC 3P USA Plug w/ground
E	220 VAC 2P USA Plug w/o ground
F	220 VAC 3P Europe Plug
G	234 VAC 3P Europe Plug
H	234 VAC 3P Australia Plug
L	220 VAC 3P Australia Plug
Z	12 VDC w/o AC Power Supply
Remarks	
A	without Special Instructions
X	with Special Instructions

VXR5000 15 E 25 9 J - 1 C

↑ This is an example of a typical Production Code and its meaning.

Specifications

General

Freq. Range (MHz):	Vers (A) 134 - 147 (B) 146 - 160 (BS1) 156 - 168 (C) 164 - 175
Max. Ch. Spread:	2 MHz (w/o degradation)
No. of Channels:	1 - 8
Ch. Separation:	12.5 kHz / 20 kHz / 25 kHz
Frequency Stability:	± 2 ppm
Emission Type:	F3E
Tx Activation System:	carrier-operated, CTCSS tone operated, or remote control
Power Requirements:	100/117/220/234 V AC (50/60 Hz), 13.8 VDC
Input Power:	200 W AC (25 watts RF output), 30 W standby 6.0 A DC (25 watts RF output), 500 mA standby
Operating Temp.:	-30 ~ +60 C
Case Size:	375 x 275 x 110 mm (WHD)
Weight:	12 kg

Transmitter

RF Power Output:	25 Watts, continuous-duty
Maximum Deviation:	± 2.5 kHz (12.5 kHz spacing) ± 4.0 kHz (20 kHz spacing) ± 5.0 kHz (25 kHz spacing)
Audio Response:	+ 6 dB/octave (+1.0/-3.0 dB)
Audio Distortion:	<5 %
FM Noise Ratio:	40dB
Spurious Emissions:	-80 dBc

Receiver

Receiver Type:	Double-conversion, Superheterodyne
Sensitivity:	0.5 μ V (0 dB μ) for 12 dB SINAD
1st & 2nd IF:	21.6 MHz (1st I.F.) 455 kHz (2nd I.F.)
Adj. Ch. Selectivity:	70 dB
Intermodulation:	70 dB
Spurious Response:	75 dB
AF Response:	750 μ s de-emphasis

Interface

Line Port:	600- Ω 4-wire (E+M signaling)
Accessory Port:	25-pin (DB-25F type)

Specifications subject to change without notice or obligation.

VXR-5000 Options & Accessories

<u>Model No.</u>	<u>Item</u>	<u>P/N</u>
YH-2	Intercom Headset w/Boom Microphone	D3000319
VTS-100	VX-TRUNK Unit	A06150001
MR-KIT 1	19" Cabinet Rack-Mount Unit	A06500001
PD-506	VHF Cavity Duplexer Unit	D3000275
VPL-1	Programming Connection Cable	
CE-8	Software Programming Disk	
FS-100	DC Local Controller with Line Interface Unit	A07410001

Rear Panel Controls & Connectors

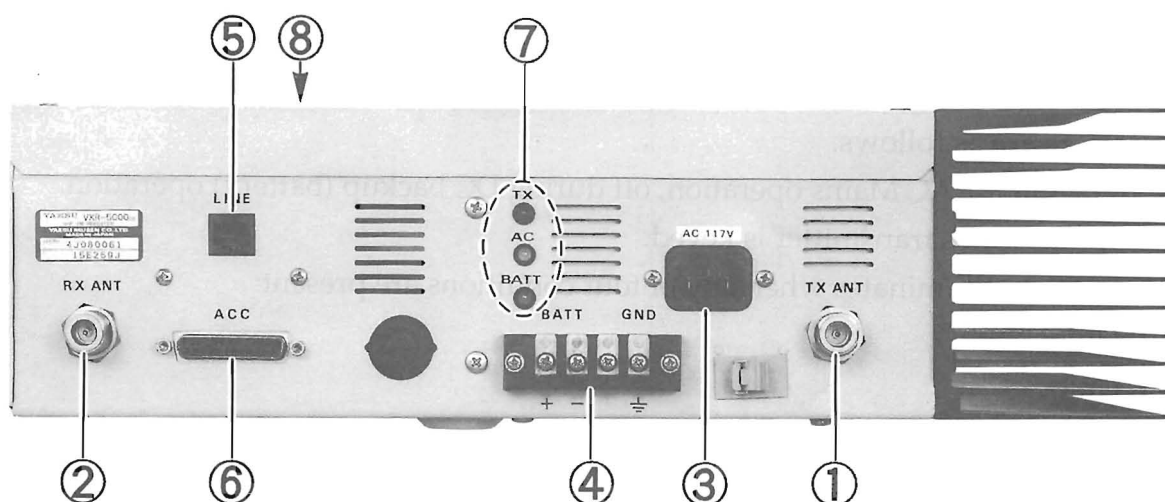

1. TX ANT

This N-type coaxial jack provides the transmitter output signal for connection to the transmitting antenna, or TX jack on the duplexer, if used. Impedance requirement is 50Ω.

2. RX ANT

This N-type coaxial jack accepts the receiver input signal from the receiving antenna or RX jack on the duplexer, if used. Impedance requirement is 50Ω.

3. AC

This receptacle accepts the AC power cord, which should be connected to the AC Mains supply or wall outlet. The AC line voltage must match that for which the repeater is wired.

4. BATT terminal posts

The terminal posts accept 12~15-V DC for operating the repeater from a battery or other DC source. When operating from AC mains, a small trickle current is present at these terminals to maintain battery charge. A battery rated for 12 volts, 55 Ah (minimum) is recommended for short-term emergency/backup operation.

5. LINE

This 8-pin modular jack is used for remote control and provides TX & RX audio, TX keying and squelch status output. Impedance is 600Ω.

6. ACC

This DB-25 connector provides a data interface between the microprocessor in the VXR-5000 and peripheral devices (such as the VTS-100 VX-TRUNK unit).

7. LED Indicators

TX - This LED glows red when transmitting.

AC - This LED glows green during AC operation.

BATT - This LED glows orange during DC operation.

8. Programming Jack (inside cabinet)

This 8-pin modular-type jack is located inside the repeater cabinet on top of the CNTL unit. The modular plug from the VPL-1 Cable or FRB-2 Service Kit cable is inserted here for channel programming using the CE-8 channel editor software, and an IBM PC®/PC-compatible personal computer with RS-232 serial port.

CNTL-1 Unit Status LEDs:

Three LED status indicators on the CNTL-1 Unit provide for visual monitoring of repeater operation while performing servicing and alignment. The repeater cabinet cover must be removed to view these.

LED indicators are as follows:

AC (D1002) - On for AC Mains operation, off during DC backup (battery) operation.

TX (D1008) - Indicates transmitter is keyed.

ALARM (D1001) - Illuminates when any of four conditions are present:

Rx PLL Unlock*

Tx PLL Unlock*

PA Module Hi Temp (PWR Reduction)*

EEPROM Data Error

**indicates parameter can also be monitored using the CE-8 Programming Software (see the EEPROM Programming Software Instructions chapter for details).*

Installation

Repeater operation without a duplexer requires that two antennas be installed, one for receiving and one for transmitting, so that the receiving antenna does not absorb energy from the transmitting antenna. There are a number of ways to do this, depending on the TX/RX frequency separation, and on the location available for antenna mounting. If a duplexer is used, a single antenna suffices for both transmitting and receiving. If using a reduced-size duplexer, a six-cavity model (minimum) is recommended.

Regardless of the above choice, it is of paramount importance that the antenna(s) be mounted as high as possible, and in the clear as possible, preferably within line-of-sight to all repeater users. Furthermore, losses in the feedline(s) must be minimized, so the feedline(s) should be high quality, and as short as possible. If a long feedline is necessary, use coaxial hardline cable to reduce losses.

Repeater antennas should have an impedance of 50 ohms at the operating frequency. When separate receive and transmit antennas are used, high-Q narrow-band types may serve to minimize interaction. However, when a single antenna is used with a duplexer, it should be a low-Q wide-band type.

NEVER TRANSMIT WITHOUT HAVING A TRANSMIT ANTENNA CONNECTED TO THE REPEATER.

AC Power Supply Voltage Selection

Each repeater is wired for a particular AC mains voltage between 100 and 234 VAC. This should be indicated by a label near the AC jack on the rear panel. If no label is present, or if the AC voltage on the label is different from the local AC line, check the wiring to the power transformer inside the repeater, and change the connections (and label) if necessary, as shown on the following page.

Changing the transformer wiring also requires changing the fuse in the power supply if the voltage is changed from below 117-V AC to above 200 VAC, or vice-versa. Use a

5-amp fuse for for 117 VAC or less, or a 3-amp fuse for 200 VAC or more.

Operation

DC Power Supply Backup

For uninterrupted operation during power failures, a 12-volt rechargeable type battery (55-Ah or more recommended) may be connected to the DC terminal posts on the rear panel. While the repeater is operating from the AC source, a slight charging current will maintain battery charge. In the event of AC power outage, the automatic power control circuit will automatically switch the repeater to the backup battery, and operation will not be interrupted.

After prolonged operation from the battery, it should be disconnected from the repeater and recharged separately before re-connecting, as the trickle charge is not sufficient for recharging a completely discharged battery. *Never reapply AC power to the repeater with a discharged battery connected, as the DC startup current can damage the repeater and battery.* While operating from a battery or DC supply, the repeater requires approximately 7 amperes at 12 volts during transmit.

Equipment Location

While the operating temperature range of the repeater is quite broad, the best location is still one in which the air temperature does not approach the extremes or change rapidly. Make sure to allow for free air circulation around the heatsink on the rear apron at all times. In warm climates, the repeater should not be sealed in a small closed room.

Protect the repeater from wind and rain, and extremes in temperature or humidity that may shorten the useful life of the equipment. Try to locate the repeater in an environment that is also comfortable for service personnel, if possible.

Changing Power Transformer AC Mains Wiring

Before attempting this wiring change, remove the AC power cord from the rear panel jack.

- ❑ Remove the four screws affixing the top cover of the repeater, and remove the cover.
- ❑ Note the location of the AC fuse, and the three screws affixing the clear protective plastic sheet to the repeater (one screw near the fuse block, and two on the PA Unit).
- ❑ Remove the four screws and the plastic sheet.

- ❑ Referring to the diagram below, determine the correct transformer primary jumper wiring for the AC Mains voltage used in your area.
- ❑ Next, using a medium power (approx. 30-watt) soldering iron, rewire the jumpers according to the diagram.
- ❑ If necessary, replace the AC fuse according to the AC Mains voltage range:
 - 100~117-V AC: 5A
 - 200~234-V AC: 3A
- ❑ Replace the clear protective sheet and cover, this completes the wiring change.

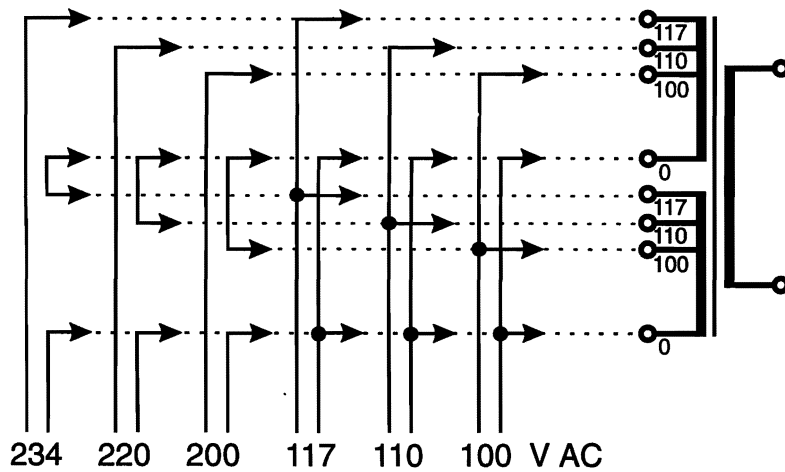

AC Mains Voltage Selection

Important!

If you change the AC voltage range, *you must also change the rear-panel AC fuse*. Do not replace with a slow-blow type fuse. Also make sure the voltage marking on the rear-panel label matches the new voltage setting.

Caution!

To avoid blowing the rear-panel AC fuse, wait at least 30 seconds after un-plugging the repeater AC power cord before plugging it in again. This allows the DC power supply capacitor-bank residual voltage to bleed down, and prevent a high start-up current when power is reapplied.

Repeater Mounting & Installation

Rack Mount

The optional MR-KIT 1 bracket kit is required for installation into an EIA-standard 19-inch rack. When stacking multiple VXR-5000 units in a rack, use forced air cooling. In addition, repeater output power should be reduced by approximately 50% when continuous duty operation is expected.

- ❑ To install the repeater, first remove the top cover and locate the three mounting holes.

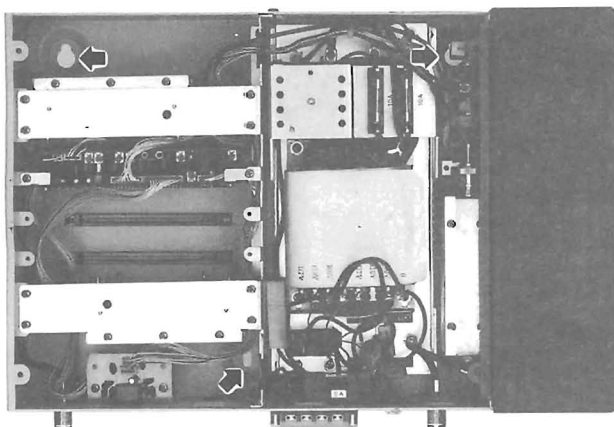

- ❑ Attach the VXR-5000 to the mounting cradle using the three supplied screws, then replace the protective sheet and top cover.
- ❑ Next, install the cradle front panel using three machine screws along the panel bottom, and one rack mount handle (two screws each) on each side.
- ❑ Insert the unit into the rack cabinet and secure it with four screws.

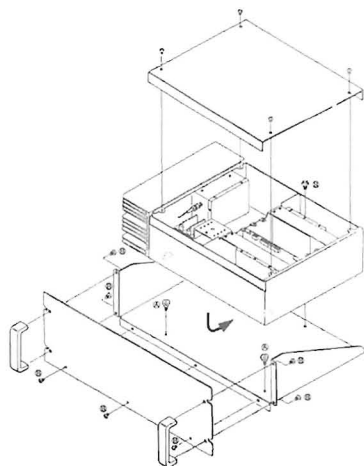

Wall Mount

The repeater can be affixed vertically to a wall using the three mounting holes in the bottom panel of the repeater chassis.

- ❑ Remove the top cover of the repeater and clear protective sheet, then locate the three mounting holes.
- ❑ Lay the repeater flat on a large sheet of paper or cardboard, and trace the outline of the mounting holes onto the paper to make a drilling template.

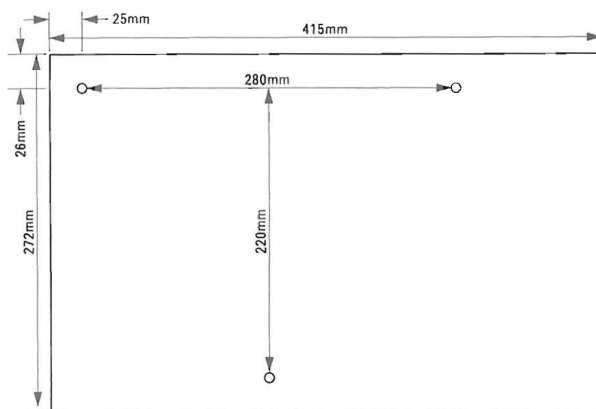

- ❑ Drive three large screws (not supplied) into the wall studs (anchor bolts can be used for concrete walls), leaving approximately 1 cm of the screw exposed.
- ❑ After aligning the repeater chassis mounting holes with the three exposed screws (or anchor bolts), hang the repeater in place, then drive the screws home to securely attach the repeater (see below).

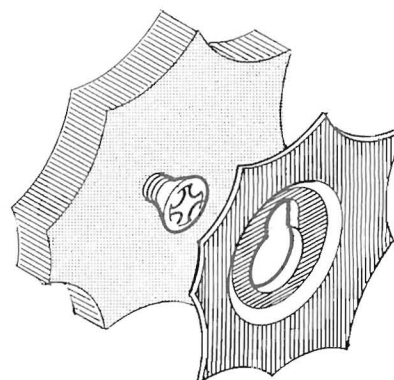

Notes:

VTS-100 VX-TRUNK I Interconnection

The VTS-100 VX-TRUNK I rack-mount unit is used with the VXR-5000 as part of a land-mobile trunking system. The VTS-100 connects to the repeater using the DB-25 connector (**ACC**). Interconnection requires a cable constructed according to the diagram below.

For VTS-100 operation, free the CNTL Unit card from the chassis as described later under *Cover Removal and Unit Access*, then slide switch S2001 on CNTL Unit 2 to the **HI** position, as shown at the right.

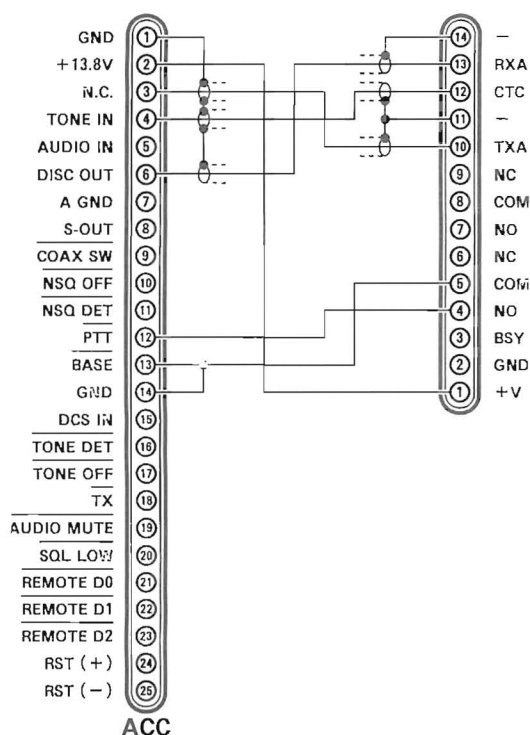
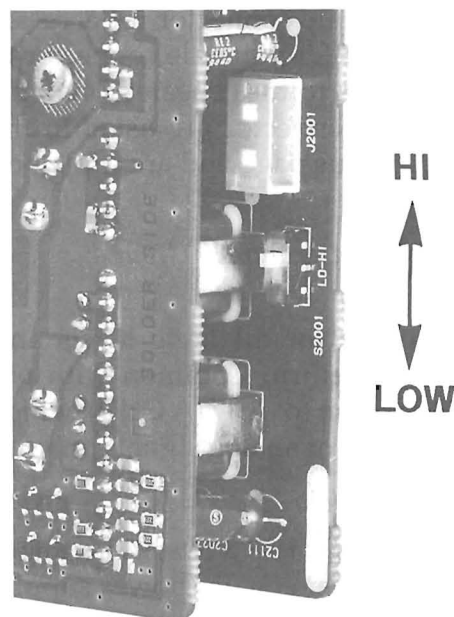

VXR-5000 VTS-100

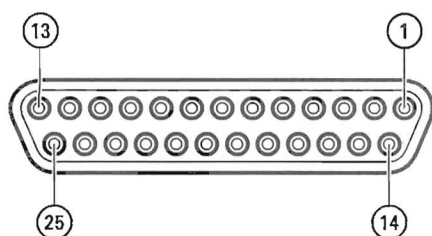

**ACC Jack
DB-25 Pin Numbering**

ACC Connector DB-25 Pin-Out Data

Pin	Signal	Logic I/O	Active State
1	GND	Logic & PS ground	N/A
2	+13.8 V	N/A	N/A
3	TX AUDIO IN	Analog Tx input	N/A
4	TONE IN	Analog TX input	N/A
5	AUDIO IN	Analog Input	N/A
6	DISC OUT	Analog Output	N/A
7	AUDIO GND	Analog Ground	N/A
8	S-METER OUT	Proportional output	N/A
9	COAXIAL SWITCH	Logic Output	Active Low
10	NSQ OFF	Logic Input	Active Low
11	NSQ DET	Logic Output	Active Low
12	PTT	Logic Input	Active Low
13	BASE	Logic Input	Active Low
14	GND	Logic & PS ground	N/A
15	DCS IN	DCS/LTR Data Input	< 2.5V = logic 0 > 2.5V = logic 1
16	TONE DET	Logic Output	Active Low
17	TONE OFF	Logic Input	Active Low
18	TX	Logic Output	Active Low
19	AUDIO MUTE	Logic Input	Active Low
20	SQL LOW	Logic Input	Active Low
21	DATA 0	Logic Input	Active Low
22	DATA 1	Logic Input	Active Low
23	DATA 2	Logic Input	Active Low
24	RST (+)	Logic Input	level of 3-5 V DC causes CPU reset
25	RST (-)	Logic Input	

VXR-5000 Accessory Connector

The VXR-5000 repeater is provided with a 25-pin DB-25F female connector for accessories. Use a DB-25M 25-pin male connector to connect accessories to the repeater. The pins on the accessory connector are listed in the table on the previous page and are explained in detail as follows:

1. GND Logic and Power Supply Ground Connection

Chassis ground for all logic levels and power supply return. Common with pin 13. Do not connect to pin 7 (A GND), which is for grounding of analog signals only.

2. +13.8 V Power Supply

This pin provides 13.8 volts, 1.0A, regulated DC from the repeater power supply. Use an 1A fuse to prevent damage to the repeater.

3. TX AUDIO Analog Transmitter Input (Voice Band 300 -3000 Hz)

Approximately 0.245 V_{rms} audio input on this pin will produce full system deviation at 1 kHz (i.e. with 25 kHz channel spacing, \pm 5-kHz deviation). Input impedance is 600 Ω . This audio is injected before transmitter pre-emphasis and limiting stages, so excess signal input levels are clipped.

This pin is intended to be used as a voice-band input to the repeater for telephone patch audio, line control panel audio or community repeater tone panel audio. The repeater must be in BASE mode (pin 13 grounded) for signals on this pin to be fed to the transmitter. The absolute level on this pin can be adjusted by VR2001 (LINE SENSITIVITY control) and also by S2003, which provides 10 dB attenuation, both on the CNTL-2 Unit. Use shielded cable to connect to this pin, connecting the shield to pin 7 (A GND).

4. TONE IN Analog Transmitter Input (Sub-Audible Band 67-250 Hz)

Applying a 0.1 V_{rms} sub-audible tone produces 10% of full system deviation. This input is high impedance (approx. 10 k Ω), and has a flat response characteristic (repeater deviation is constant for a given

signal level over the frequency range of 67-250 Hz). This pin is intended to be used for CTCSS transmission from a community repeater tone panel. This input is applied after limiting and pre-emphasis, and therefore exhibits flat direct FM input characteristics.

Injecting too high a voltage here causes over-deviation of CTCSS, degrading performance. Signals with DC content (DCS or LTR data) *should not* be connected here, but to pin 15. If the repeater is fitted with internal CTCSS, then its output will be present on this pin. Use shielded cable to connect to this pin, connecting the shield to pin 7 (A GND).

5. AUDIO IN Analog Input

Set S2005 on the CNTL-2 Unit to **EXT** to enable audio input to the LINE OUT using this pin. This allows Rx audio to be intercepted (at the DISC OUT pin, see below), and externally processed for special applications, such as descrambling. The normal position of S2005 is **INT**, and in this case, AUDIO IN signals come from Rx audio.

6. DISC OUT Analog Output (Wide-Band 0-3000 Hz)

Received signals with full system deviation produce 1 V_{p-p} audio at this pin. The output is low impedance, and is extracted before de-emphasis and squelch circuitry. This pin should be used as the Discriminator Audio Signal required by most community repeater tone panels and telephone patch units. Use shielded cable to connect to this pin, and connect the shield to pin 7 (A GND).

7. A GND Analog Ground

Connect the shields of any accessory analog signal lines to this pin. Do not connect this pin to pin 1 or pin 13, as an audio hum loop may result.

8. S-OUT S-Meter Output

A DC voltage proportional to the strength of the signal currently being received (Receiver Signal Strength) is output on this pin. This low impedance output is generated by the receiver IF sub-system and

buffered by an internal op-amp. Typical voltages are graphed as follows:

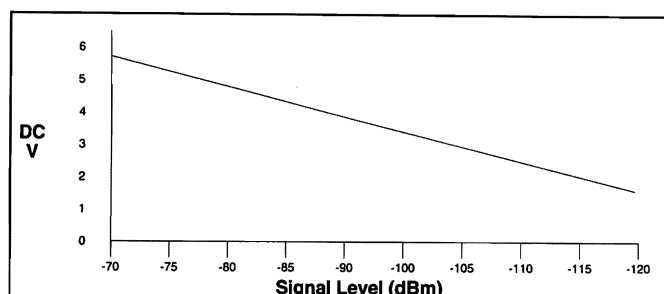

S-Meter Output Proportional Voltage Graph

9. COAX SW Logic Output (Active Low)

This output is intended for controlling an external coaxial switching relay. It is an open collector output which can sink approx. 100 mA when active. This signal only switches if the repeater has been programmed for simplex mode. If programmed for duplex, the signal remains open (at high impedance) at all times.

10. NSQ OFF Logic Input (Active Low)

This input is internally pulled up to 5-V DC. When pulled low by an external device, receiver squelch is canceled. If the internal CTCSS decoder is programmed, pin 17 (TONE OFF) should also be pulled low during monitoring. If the repeater is in the REPEATER mode, the transmitter is *not* keyed when this pin is activated, but an incoming signal on the receiver channel *does* cause the transmitter to be keyed and the signal repeated as normal. Do not apply more than 5 V to this pin, as this can damage the CNTL-1 Unit CPU.

11. NSQ DET Logic Output (Active Low)

This is an open-collector, active-low output capable of sinking about 100 mA. It indicates that the receiver squelch is open. If the squelch control is properly set, this indicates a carrier on the receiver channel, and is sometimes referred to as a COR (Carrier Operated Relay) signal. Some telephone interconnect panels and community repeater tone panels require this signal.

12. PTT Logic Input (Active Low)

This input is internally pulled up to 5-V DC. When pulled low by an external device, it keys the repeater transmitter, provided that the BASE signal is present on pin 13 (indicating the repeater is in the base mode of operation). The pin has no effect if the BASE signal on pin 13 is not present (i.e. the REPEATER mode is selected). Avoid voltage in excess of 5 V on this pin, or internal damage to the CPU on the repeater CNTL-1 unit may result.

13. BASE Logic Input (Active Low)

This input is internally pulled up to 5-V DC. In simplex mode, this pin is not normally used. However, after programming via CE-8 Software and pulled low by an external device, BASE or REPEATER modes of operation can be selected. In BASE mode, the receiver and transmitter operate independently: receiver signals do not key the transmitter. In the alternate (REPEATER) mode, a proper signal on the receive channel causes the transmitter to be keyed and modulated by receiver audio. Avoid voltage in excess of 5 V on this pin or internal damage to the CPU on the repeater CNTL-1 unit may result.

14. GND

This is the chassis ground for all logic levels and power supply return, and is also common with pin 1. Do not connect to pin 7 (A GND), which should only be used for grounding of analog signals.

15. DCS IN Digital Input for DCS / LTR data

This pin accepts sub-audible tones in the range of 6 - 136 Hz for modulation of the transmitter with DCS or LTR data. Internal buffering allows the data to be DC referenced from 5~9 VDC. Signals below 2.5 V are transmitted as Logic "0" while levels above 2.5 V are Logic "1". Voltage in excess of 9 V may cause internal damage.

16. TONE DET Logic Output (Active Low)

This open-collector output can sink about 100 mA, and is activated when the internal CTCSS detects a valid CTCSS tone at the demodulator.

17. *TONE OFF Logic Input (Active Low)*

This input is internally pulled up to 5-V DC. When pulled low by an external device, it disables the internal CTCSS decoder (if enabled). The internal CTCSS encoder section is not affected by this input. Use this input when channel monitoring with squelch action is required (e.g. tone monitor function). Voltage in excess of 5 V on this pin may damage the CPU on the repeater CNTL-1 Unit.

18. *TX Logic Output (Active Low)*

This open-collector logic output is pulled low when the transmitter is activated. It can sink approx. 100 mA. The signal on this pin is always true when the transmitter is on. It is intended to be used where an "ON-AIR" indication is required.

19. *AUDIO MUTE Logic Input (Active Low)*

This input is internally pulled up to 5-V DC. When pulled low by an external device, it disables receiver output to pins 5 & 6 of the modular LINE jack. In the REPEATER mode, the repeat audio is not affected by signals on this pin. Avoid voltage in excess of 5 V on this pin or internal damage to the CPU on the repeater CNTL-1 Unit may result.

20. *SQ LOW Logic Input (Active Low)*

This input is internally pulled up to 5-V DC. When pulled low by an external device it selects the low squelch mode. In low squelch mode, the hysteresis between squelch open and closed is only 3 dB (instead of the normal 6 dB). The squelch closing level is unchanged.

The absolute squelch closing level is set by VR4001 on the RX Unit. For example, if the squelch on the RX Unit has been set to open at -110 dBm in normal mode, then

with the SQ LOW pin grounded, the squelch will now open at about -113 dBm. In either case, the squelch will close at -116 dBm. Avoid voltage in excess of 5 V on this pin, which could damage the CPU on the repeater CNTL-1 Unit.

21, 22 & 23. *REMOTE D0, D1 & D2 Logic Inputs (Active Low)*

These inputs are internally pulled up to 5-V DC. When pulled low by an external device, they select one of the eight pre-programmed repeater operating channels. The logic truth table below shows the combinations for selecting all 8 channels.

In the truth table, "1" represents no connection, and "0" represents a ground connection on the pin.

The channel selection logic is not inhibited while the transmitter is keyed: the repeater will change frequency when instructed, even while transmitting.

Avoid voltage in excess of 5 V on these pins or internal damage to the CPU on the repeater CNTL-1 Unit may result.

VXR-5000 Channel Access (D0-D2, pins 21, 22 & 23)			
CH	D2	D1	D0
1	1	1	1
2	1	1	0
3	1	0	1
4	1	0	0
5	0	1	1
6	0	1	0
7	0	0	1
8	0	0	0

24 & 25. *RST+ & RST- Logic Inputs*

An opto-isolated RESET input is provided between pins 24 and 25. A voltage of between 3 and 15 V resets the repeater microprocessor.

VXR-5000 Line Interface Port

The VXR-5000 is provided with an 8-pin modular jack for line interfacing applications. A Western Electric modular-type RJ45 plug should be used to connect to the jack. The **LINE** jack provides -10 dBm line-level audio for two uses:

- Provides an impedance-balanced, 4-wire audio port with E+M auxilliary signalling.
- Provides audio for SINAD meter connection during alignment procedures (see diagram on page 4-1).

LINE jack pin-out is shown below.

Note that there are both 4-line and 8-line types of modular plugs. If a 4-pin modular plug is used, only the **LINE OUT** and **LINE IN** connections will be made. An 8-pin plug is required to access all lines. In accordance with standard telecommunications interfacing, the line connections on the **LINE** interface jack are impedance balanced, and are described as follows:

Pins 1 & 2. *RX SQ+*, *RX SQ-*

An opto-isolator is provided to facilitate E signaling (**EAR**). The opto-isolator comes on when a signal exceeding the receiver squelch appears on the receiver channel (with correct CTCSS tone, if enabled). The **RX SQ-** pin is the emitter, and **RX SQ+** is the collector.

Pins 3 & 4. *LINE IN Tx Line Audio*

Analog signals between 300 and 3000 Hz supplied to this pair are fed to the transmitter when the repeater is set to the **BASE** mode (**ACC** connector, pin 13 grounded) and keyed either by the **TX KEY** input signal (see below), or by the **PTT** signal on pin 12 of the **ACC** jack. Full system deviation is obtained with a line level of -10 dBm.

Pins 5 & 6. *LINE OUT Rx Line Audio*

Receiver audio is available from this pair, subject to internal CTCSS decode if the received signal strength is above the squelch threshold. Receiver audio can be monitored by activating the **NSQ OFF** signal on pin 10 of the **ACC** jack.

As shipped from the factory, a 1-kHz receiver signal with full system deviation gives -10 dBm on the line, but this can be varied over the range -55 dBm to +10 dBm by VR2006 and S2004 on the repeater **CNTL-2** Unit.

Pins 7 & 8. *TX KEY+*, *TX KEY-*

An opto-isolator is provided to facilitate M signalling (**MIC**). That is, a voltage presented to these pins turns on the opto-isolator and keys the transmitter. The **TX KEY+** pin is the anode of the opto-isolator and **TX KEY-** is the cathode.

Socket J8201

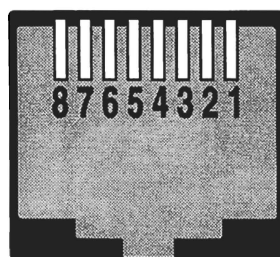

- 1 Rx SQL +
- 2 Rx SQL -
- 3 Line IN
- 4 " "
- 5 Line OUT
- 6 " "
- 7 Tx Key +
- 8 Tx Key -

LINE jack pin-out

Cover Removal and Unit Access

The VXR-5000 repeater uses professional modular card-style unit construction and mounting. Major units are secured in a miniature rack-mount cage for easy access and servicing. Each unit can be removed by unscrewing the mounting-tab screws, unplugging the cables to the unit, then sliding the unit out from the chassis. Plastic guide rails on the chassis body ensure positive insertion and support the units firmly in place.

Opening the Repeater Cabinet

- To remove the cover, remove the 4 screws as shown below and lift the cover off. Unit identification and locations are shown below.

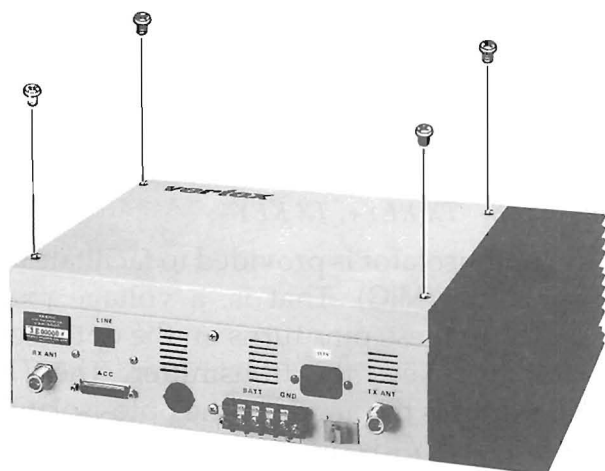

Control Unit Access

- Remove the two screws from the Control Unit mounting tabs to loosen it from the chassis.

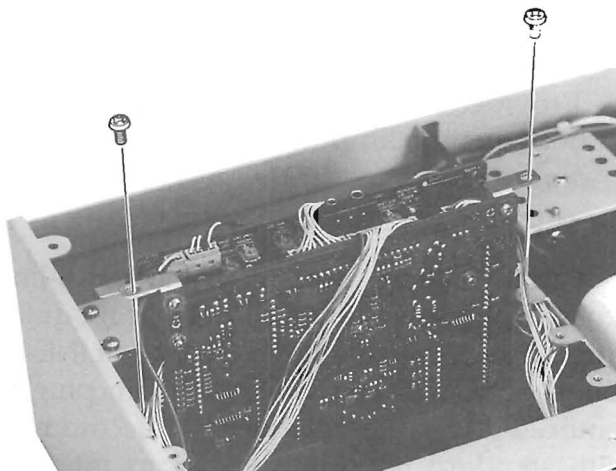

CNTL Units 1 & 2

TX Unit Access

- Remove 4 screws from the TX unit mounting tabs to loosen it from the chassis.
- Remove the 10 screws affixing the top cover, and lift it off (note the type of screws used) to expose the VCO Unit.

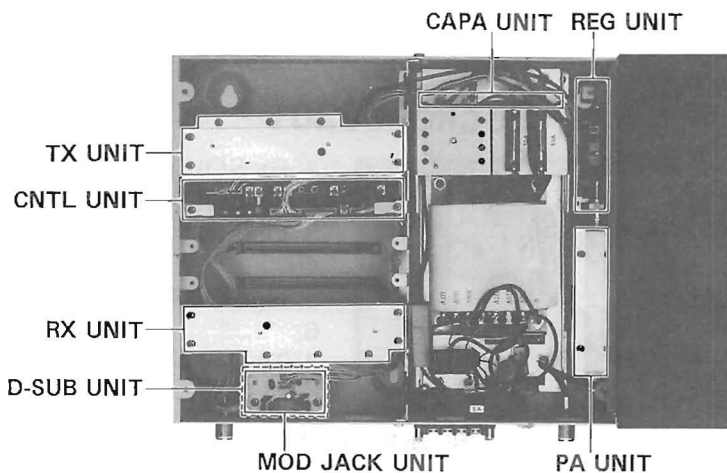

Unit Location & Identification

- This completes normal disassembly for servicing, to completely remove the unit, disconnect the TX coaxial cable from the BNC jack, and unplug the two cables leading to the CNTL Unit from J3001 & J3002.

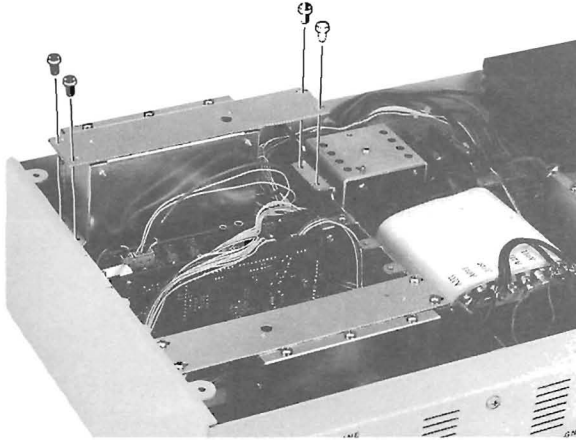

TX Unit

PA Unit Access

- First remove the 6 large screws affixing the heat sink/PA Unit to the chassis. Loosen the heat sink unit from the chassis.

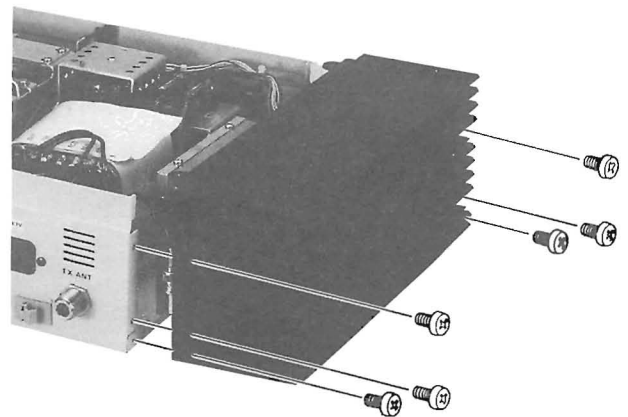

RX Unit Access

- This unit is removed in the same manner as described for the TX Unit. Control Unit cables connect to J4001 & J4002. To completely remove the unit, disconnect the coaxial cable leading to the RX ANT jack from the BNC jack.

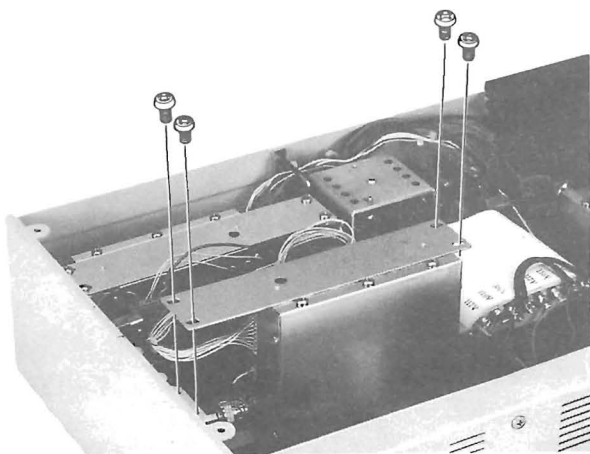

RX Unit

- Next remove the TX ANT cable from the BNC connector on the TX Unit, and remove the 8 screws affixing the top cover to expose the PA Unit (see below).

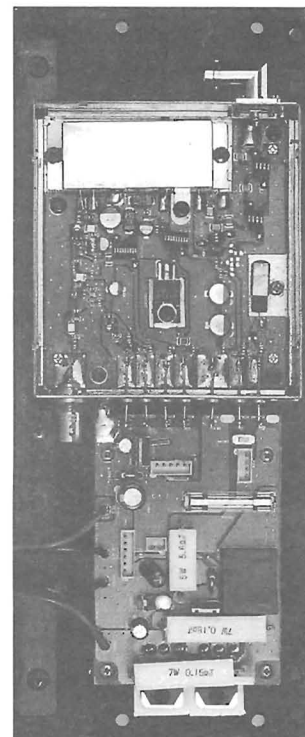

TX PA Unit

Notes:

Circuit Description

Receive Signal Path

Incoming RF from the RX antenna jack is delivered to the RX Unit and passes through the bandpass filter consisting of coils L4002, L4003 and L4005, capacitors C4016, C4017, C4019, C4021 & C4023. Signals within the frequency range of the receiver are then amplified by Q4010(3SK131). The amplified RF is then bandpass filtered again by L4011, L4013, L4015, and C4046, C4050, C4054, C4057, C4061 and C4067 to ensure pure in-band input to the first double-balanced mixer D4003 (DBM0135).

Buffered output from the VCO Unit is amplified by Q4011 (2SC3357) and low-pass filtered by L4014, L4016, C4056, C4060, C4062 and C4066, to provide a pure first local signal between 112.4 MHz and 152.4 MHz to the first double-balanced mixer. The 21.6 MHz first mixer product is amplified by Q4018 (2SC3356), then passed through dual monolithic crystal filter (± 7.5 kHz BW) XF-4001 (21P15BU-1), to strip away all but the desired signal, which is then amplified by Q4024 (2SC3356).

The amplified 1st IF signal is then applied to FM IF subsystem IC Q4017 (MC3372ML), which contains the 2nd mixer, 2nd local oscillator and limiter amplifier. A 2nd L.O. signal generated from the 22.055 MHz crystal X4003, produces the 455 kHz 2nd IF when mixed with the 1st IF within Q4017. The 2nd IF then passes through ceramic filter CF4001 (CFW455E), to strip away any unwanted mixer products, and is then applied to the limiter amp in Q4017, which removes any amplitude variations in the 455 kHz IF before detection of speech by ceramic discriminator CD4001 (CDB455C16). The detected audio is amplified by Q4016 (NJM2902M) and delivered to J4002-pin-1 (DISC OUT).

Squelch Control

When no carrier is received, noise at the output of the detector stage from Q4017, pin 9 is sampled and fed to squelch gate Q4021 (2SA1179), VR-4001 adjusts the squelch threshold before delivery to the 3-pole active bandpass filter formed by Q4025 and Q4026

(both 2SC2812), where the audio is de-emphasized and audio frequencies above 5-kHz are rejected. The noise signal is next amplified by Q4023 and Q4020 (both 2SC2812), then rectified by diode D4004(1SS226) to produce a DC control voltage for the squelch switch section in Q4022. This resulting DC voltage is amplified by Q4016-4(NJM2902M), then compared with a reference voltage of 9 VDC at Q4016-3. The open-collector output voltage from analog switch Q4022 (DTC144EK) is delivered to J4001 pin 7 (NSQ DET) and on to microprocessor Q1009 pin 26 (NSQ DET).

Then, microprocessor pin 14 (LINE OUT) goes high, turning on analog mute gate Q2001 (NJU4066DM) on Control Unit 2, allowing audio to pass from J2007, pin 1 (DISC IN) through audio stages Q2008 and Q2006 to line selector Q2004 (uPD4052BG).

CTCSS Operation

A CTCSS (Continuous Tone-Coded Squelch System) is provided by programming via CE-8 Software. The CTCSS IC Q2008 (MX165CLH) contains a CTCSS tone encoder for any one of 39 subaudible tones. The CTCSS audio level output from pin 16 of Q2008 is amplified by Q2005-1(NJM2902M), and adjusted by VR2003 before injection into the audio chain at Q2003-2 (NJM2902M).

S-Meter

S-meter signal is output from pin 13 of Q4017(MC3372ML) to C4118 where the 455 kHz signal is rejected(filtered), to buffer amplifier Q4016-2(NJM2902M) through J4001 pin 1 to CNTL Unit-1.

RX PLL & VCO Circuit

PLL circuitry on the RX unit consists of PLL subsystem IC Q4014(MC1415190F), which contains a reference oscillator/divider, serial to parallel data latch, programmable divider, phase comparator and a swallow counter. Stability is obtained by a regulated 5-VDC supply via Q4001 (TA78L05) to Q4009 (DTA143EK) and temperature compensating capacitors associated with the 12.8 MHz frequency standard X4002 (GFS-720).

RX Unit VCO Q5502 (2SK302GR) oscillates between 112.4 and 152.4 MHz according to the programmed receiving frequency and repeater version type. A sample of the VCO output is amplified by Q4015 (2SC3356) and returned to the prescaler/swallow counter in Q4014. There the VCO signal is divided by 64 or 65, according to a control signal from the data latch section of Q1009 on CNTL Unit 1, before being applied to the programmable divider section of the PLL chip.

The data latch section of Q4014 also receives serial dividing data from microprocessor Q1009 on CNTL Unit 1, which causes the pre-divided VCO signal to be further divided by 11,240 ~ 15,240 in the programmable divider section, depending upon the desired receive frequency, so as to produce a 10-kHz or 12.5 kHz derivative of the current VCO frequency. Meanwhile, the reference divider section of Q4014 divides the 12.8 MHz crystal reference by 1280 (or 1024) to produce the 10-kHz (or 12.5-kHz) loop reference.

The 10-kHz or 12.5 kHz signal from the programmable divider (derived from the VCO), and that derived from the crystal are applied to the phase detector section of Q4014, which produces a dual phase-detected 9-VDC pulsed output with pulse duration depending on the phase difference between the input signals. This pulse train is then converted to DC, low-pass filtered, then fed back to varactor diodes D5501, D5502, D5503 & D5504 in the RX VCO Unit.

Changes in the DC voltage applied to the varactor diodes affect the reactance in the tank circuit VCO Q5507, changing the oscillating frequency according to the phase difference between the signals derived from the VCO and the crystal reference oscillator. The VCO is thus phase-locked to the reference frequency standard. The output of RX VCO Q5507, after buffering by Q5501, is delivered for amplification to Q4012 (2SC3356) & Q4011 (2SC3357) before application to the first mixer, as described previously.

Transmitter

Transmitter VCO Q5002 (2SK302GR) oscillates between 134 -174 MHz according to the programmed TX frequency and repeater version type. The theory of operation of the remainder of the PLL circuitry is similar to that of the RX VCO Unit, however, dividing data from the microprocessor is such that the VCO frequency is the actual transmit frequency.

IDC-processed speech audio from CNTL Unit 2 is pre-emphasized by C2010, R2006 and Q2002-4(uPC4747) before application to the TX VCO. To prevent over-deviation, the audio is processed by IDC (instantaneous deviation control) circuitry on CNTL Unit 2 before delivery to the TX Unit. Speech audio is delivered to diode D5006 (1T363) from Control Unit 2, frequency modulating the PLL carrier up to ± 5 kHz from the unmodulated carrier at the transmitting frequency.

DCS modulation from control Unit 2 is low pass filtered by Q3002 (NJM2904M), then applied to both the VCO and to the PLL frequency reference, via reference frequency standard X3001(GFS-720). The modulated signal from TX VCO unit is buffered by Q5001 (2SC3356) and Q3011 (2SK1577), then passes through buffer-amp Q3010 (2SC3356). The signal then passes through RF diode switch D3003 (HSU277) and amplifier Q3009 (2SC3356). The signal level is then attenuated before delivery to the PA Unit. The signal first passes through the low-pass filter formed by inductor L6001 and capacitor C6003 and then buffer amp Q6001 (2SC2954) before being applied to pre-driver amplifier Q6002 (2SC2954).

The transmit signal is then finally amplified by PA module Q6003 (M67741[[H] in C-versions, M67741[L]-in A&B Versions) up to 25 watts. Harmonic and spurious radiation in the final output is suppressed by a 5-pole low-pass filter formed by inductors L6008, L6009 and L6010 and capacitors C6016, C6017, C6018, C6019 and C6020 on the PA Unit before delivery to the TX antenna jack. If a CTCSS tone is enabled for transmission, the sub-audible tone from the unit is low-pass filtered, then mixed with the IDC-processed speech audio.

APC (Automatic Power Control)

RF power output from final amplifier Q6003 (M67741H) is sampled by C6023 and delivered to detector diode D6003(1SS319) where it is rectified. The resulting DC voltage then passes to the REG Unit (DET). There the APC voltage is fed through buffer amplifier Q7003-1 (NJM2902M) to comparator Q7003-4 (NJM2902M) where the voltage is compared with a reference voltage from the CPU (POWER REF) to produce a control voltage for the Automatic Power Controller Q6005 (2SB1134R) on the PA Unit, which regulates supply voltage to RF power module Q6003, to maintain stable high or low output power under varying antenna loading conditions.

CNTL-1 Unit

CNTL-1 Unit consists of 8-bit CPU Q1008 (M38063EGP), 256-kByte EPROM Q1015 (TMS27C256), EEPROM Q1002 (BR93C56), and various analog switches. Microprocessor operational code is stored in Q1015, while channel and optional data, and repeater configuration information, is programmed from an external PC at 4800 bits/sec. connected to J2008 on CNTL-2 Unit, and stored in Q1002 via programming cable connection to J2008 on CNTL Unit 2.

The output from CPU Q1008 contains three-line serial control data (DATA, CLOCK & ENABLE) used for repeater/base mode control, TX and RX PLL data, and to control analog switch Q2004 (NJU4066-BM) on CNTL-2 Unit. Crystal X1001 oscillates at 4.9152 MHz, and provides stable clock timing for the microprocessor. When the repeater is powered on, the voltage at pin 71 becomes stable, and the output of voltage detector IC Q1017 (Q1008 pin 25-RST) becomes high, resetting the CPU.

The CPU initialization routine loads the operating program from RAM, frequency and other system data from Q1002. The CPU then sends PLL and analog switch control data (J1001 pins 2, 3, & 4; and J1002 pins 2, 3 & 4), to prepare the repeater for operation. If an abnormal signal (such as PLL unlock or HI TEMP) is detected at pin 2 or pin 6 of the CPU, CPU pin 12 becomes low, inhibiting transmission by disabling the TX voltage rail.

Watch-Dog Timer

Watch-Dog Timer Q1018 (MC74HC4060F) monitors the CPU for thrashing. When abnormal CPU operation occurs, Q1008, pin 70 goes low, pulling diode OR gate D1018 (DAN202K), which in turn enables the pulse train generated by Q1018 to be input to pin 12.

Q1018, pin 1 then outputs a control pulse to transistor driver Q1020 (FMG2), which in turn switches the output of 5-V DC regulator Q1017 low, resetting microprocessor Q1009 at pin 25.

Three LEDs are used on CNTL-1 Unit for TX, ALARM and AC indications. The TX LED indicates the repeater is transmitting, the ALARM LED warns of four possible conditions: PLL unlock (TX & RX), high final amplifier temperature, EEPROM programming data loss and microprocessor thrashing.

CNTL-2 Unit

CNTL-2 Unit contains most of the analog switching gates used to control the various repeater interconnections. RX & TX speech audio is processed here.

Base Operation (TX, line-input audio)

Line input from J2001 pins 3 & 4 is impedance matched by transformer T2001, then delivered to audio selector Q2001 (MC14053BF). Line level can be attenuated by switch S2001 and line sensitivity can be adjusted to $-10 \text{ dB} \pm 10 \text{ dBm}$ by potentiometer VR2001 to compensate for audio line level variations. Part of this audio is amplified by Q2015 (TDA7233D) for local speaker output.

Line audio then passes through analog switch Q2004-3 (NJU4066BM) where the audio is pre-emphasized (+6dB/octave) by C2013 & R2018 and Q2002-4 (NJM2902). The audio then passes through IDC (instantaneous deviation control) amplifier Q2003-1 (NJM2902M). Potentiometer VR2002 sets maximum deviation. The signal is then amplified by Q2003-2 before passing through the 5-section active low-pass filter formed by Q2003-4 and Q2003-3, where frequencies above 3 kHz are attenuated and bandwidth is limited to prevent over-deviation.

The CTCSS Tone audio level output is adjusted by VR2006 then delivered to Q2002-3 and the transmitter line input.

Modulated audio from the Rx unit is delivered to J2008-1 where it is fed through int/ext audio select switch S2002 to Chebyshev Filter Q2008-3 (NJM2902M) and then high-pass filtered by R2118 and R2146. The output is then delivered to five-section, active HPF Q2008-1 which rejects audio frequencies below 300 Hz. 3-pole active LPF Q2006-3 rejects audio frequencies above 3000 Hz.

Audio is de-emphasized by Q2006-2 (uPC4741G2) and R2043 & C2036, providing flat audio response from 300 Hz ~ 3 kHz. The filtered audio then passes through attenuator S2004 and LINE output level potentiometer VR2003 to buffer amplifier Q2006-4 (uPC4741G2) and impedance matching transformer T2002 to LINE jack J2001 pins 1 & 2.

Repeater Operation

Duplex Operation

The demodulated audio is delivered from the RX unit to Q2008 and is high-pass filtered and de-emphasized as described above. Repeater "sensitivity" is adjusted using VR2005 before delivery to Q2005 (uPC4741G2) via repeater switch S2001-3. When the repeater mute switch Q2001-4 is closed, the gain of Q2005 is reduced to 0, effectively muting repeater audio. Repeater audio deviation is controlled by potentiometer VR2004 before the signal is delivered to audio amplifier Q2003-4, where the signal is processed in the same manner as previously described.

Intercom Function

Inserting a standard speaker/mic headset into the **INTERCOM** jack (J2010) provides closed-loop audio for test/communications with an installed remote base, for use by service technicians. Inserting the headset into the jack disables speaker audio via J2002, pins 1 & 2. Headset microphone audio is delivered to buffer amplifiers Q2007-3 and Q2007-4 (both NJM2902) before application to line audio selector Q2004.

Note!

If using the optional YH-2 headset, you can connect into either the line or Tx/Rx circuits for maintenance or testing.

Insert the **MIC/EAR** plug of the YH-2 into J2009 on the CNTL-2 unit, then slide the **INTERCOM** switch (S2003) to the desired position:

NOR - normal operation, the line is connected to the Tx/Rx circuits.

TRCV - the YH-2 is connected to the radio Tx/Rx circuits, and the base station can be keyed by pressing the blue PTT button on the CNTL-1 Unit.

LINE - the YH-2 is connected to the line; keying is not required.

Headset level is adjusted by **MON-LVL** (VR2007) on the CNTL-2 Unit. The default setting is minimum (fully counter-clockwise). Note! - remember to set the switch at **NOR** for normal operation *when the YH-2 is removed*.

Power Supply

The power supply includes the power transformer and bridge rectifier D0002 (S25VB20) on the chassis, a filter capacitor bank on the CAPA Unit, and various regulation and switching circuitry on the REG Unit.

AC power is applied to the primary of T0001 through fuse FH0001 and relay RL0001. The 16.5 VAC at the secondary is then dual-fused by FH0002 and FH0003 before delivery to full-wave bridge rectifier D0002 and the CAPA Unit.

The output of D0002 is then filtered by capacitor bank C8501 and C8502 and the resulting DC is applied to the collectors of Q7002 and Q7004 (both 2SD1842Q) on the REG Unit, and regulator IC Q7013 (FMW1). The control output of Q7103 is applied to the base of Q7007 (2SB1134R), the emitter of which then controls the bases of Q7002 and Q7004, thus highly regulating the voltages at the emitters. This output voltage is then delivered through relay RL7001 (FBR631D012) and fuse FH7001 to supply the 13.5 VDC bus for the rest of the repeater. A sample of the 13.5 VDC from the pass transistors is also

delivered to 9-volt regulator IC Q7001 (AN6541) to provide a regulated 9-volt output for repeater circuitry that requires it.

While operating from the AC power, regulated 13.5 VDC is fed through R7004 and D7002 (1SS226), providing a trickle charge for a battery that might be connected. If the AC power source is interrupted, the DC current from the battery then flows back through Q7016 (2SC2812), RL7001 and DC fuse, which is now switched (when AC fails) to bypass R7004 and D7002, and apply full battery voltage directly to the DC bus.

Notes:

EEPROM Programming Software Instructions

To program the Vertex VXR-5000 repeater, you will need the VPL-1 connection cable, programming diskette and an IBM PC/AT or PS/2-compatible type computer with:

- at least 512 K RAM
- PC DOS or MS DOS 2.0 or later
- one 5 1/4" (360 K or 1.2 MB) floppy drive
- a monochrome or color monitor
- one serial port (COM 1) with 25-pin connector (or suitable 9-pin adapter).

Of course you also need a printer if you want to get hard copy of the data.

The Vertex programming diskette contains the following files:

- CE8.EXE - The EEPROM programming program
- CE8.HLP - The help file used by the main program
- INSTRUCT.DOC - A text file containing a copy of these instructions (in case you mislay these instructions)

Before connecting the repeater for programming, turn off your computer and the repeater, and connect the VPL-1 programming interface cable to the computer and repeater as shown below. Then restart the computer. Turning off the equipment during interconnection avoids damage to the electronics.

When ready to run the program (after booting DOS), place your copy of the Vertex diskette (not the original!) into drive A, and log on to this drive (type A:Enter). Then type CE8 -A Enter to start the program. You should be greeted briefly by an introductory screen, as shown at the top of the next page. Depending on which data you will be editing in the VXR-5000, you may have to add a different software "switch" to the command line, see the the next page for details.

Important!

Do not work directly with the CE-8 programming diskette! Make a copy of it and use the copy when programming the repeater, since you will be storing data on it. Keep it in a safe place in case you need to make another copy of it later. The manuals that come with your computer should explain how to make a copy of the diskette, using the DOS COPY command. If you want to be able to boot your computer from the programming diskette copy, use the FORMAT command with /S parameter (on a blank diskette) to make a system disk, and then copy the files from the original diskette.

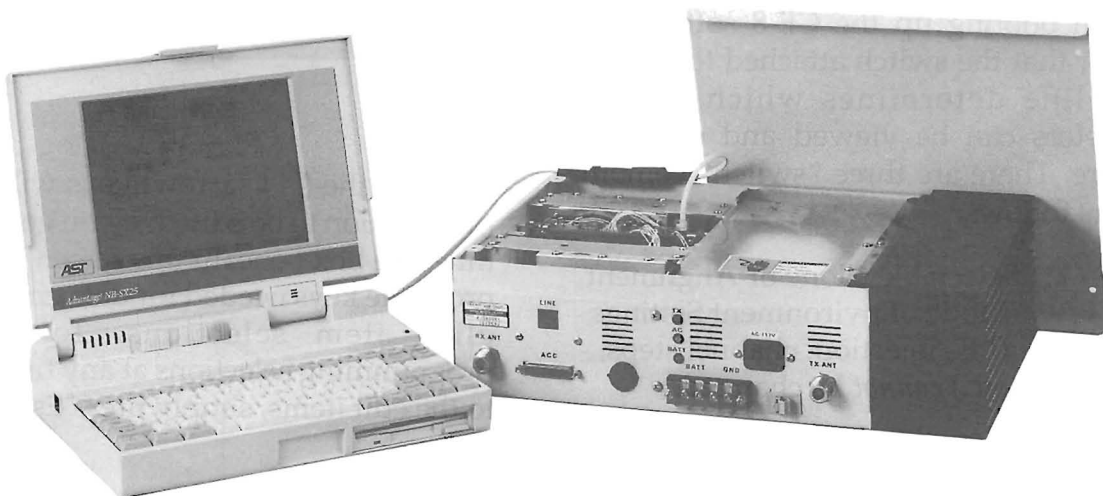

VXR-5000 Programming Setup

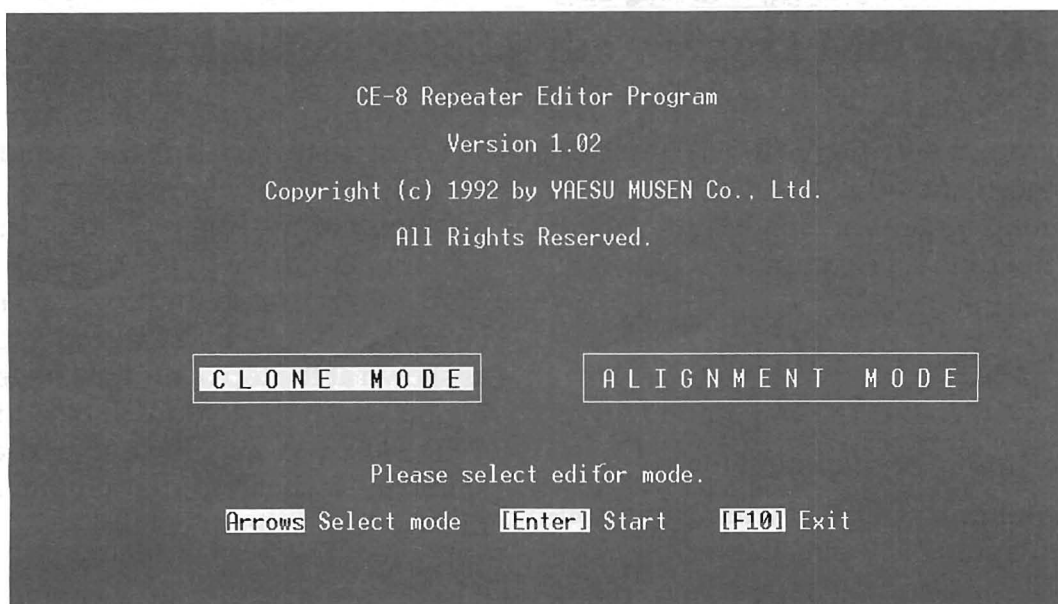

CE-8 Introductory Screen (using "-A switch)

The Programming Screen

The introductory screen (above) prompts you with a choice of "CLONE" or "ALIGNMENT" selections. Clone mode is used to program operating and repeater hardware information (such as channel data, TX/RX frequencies, IF parameters, etc).

The alignment mode is used to change I/O parameters that affect repeater/base station configuration (i.e. remote control, tone squelch settings), and when servicing the repeater (to adjust power output).

For now you will want to start with the CLONE mode, use your \leftrightarrow arrow keys to select the appropriate mode and press the Enter key to begin.

CE-8 Software "Switches"

When booting up the CE-8 software, remember that the switch attached to the command line determines which repeater parameters can be viewed and edited via software. There are three "switch" combinations, as follows;

- CE8 -A: Selectable Clone or Alignment Mode. Environment Settings (I.F., injection, channel steps, etc.) *cannot* be changed.
- CE8 -P: Clone Mode only, Environment Settings can be edited

CE8 : Clone Mode only, Environment Settings *cannot* be edited

Main Screen Display (Clone Mode)

The main screen for the CLONE mode includes five major edit items: Environment, Frequency, Timer, Setup, & Option, and, along the bottom of the screen, Function Key Selections. These are described in a bit more detail next.

Main Screen Edit Items

Each edit item at the top of the screen can be selected by using the keyboard (\leftrightarrow arrow) keys, edit programming selections will appear below in the center frame on the screen.

To choose a specific selection for data entry,

```

Environment  Frequency  Timer  Setup  Option

```

Edit Items

pressing the (\updownarrow arrow) keys will highlight the selection to be edited. If you get lost at any time, the box beneath this screen lists the appropriate keys needed for data entry and toggling item selections. To leave the programming selections at any time to return to the edit items, simply press Esc.

A brief explanation of the five main screen edit items are as follows:

Environment

Contains operating parameters used by hardware(circuitry) in the VXR-5000, including 1st I.F. selection, L.O. Injection Side, and Channel Step information. This information is hardware-specific for the repeater version-type you have, and should not need to be changed, except in the event of hardware or version-type modification. Changing environment parameters requires the CE8 -P extension when booting the program.

Frequency

Contains channel data information. Up to eight individual Tx and Rx channel frequencies are edited here, and channels can also be locked-out if so desired.

Timer

Repeater Time-Out Timer, TX Hang-Timer and Penalty Timers are edited from these selections, time values in seconds or minutes can be entered, while others preset values can be toggled on-off.

Setup

System operating configuration and parameters such as simplex/duplex operation, power output on auxiliary DC power, Hi-Temp power reduction, alarm beeper and TX Hang-Time audio selection are selected and edited here.

Option

CTCSS Tone Encode/Decode frequency selection can be made. One of thirty-nine EIA standard CTCSS tones can be programmed for each channel (TX & RX), CTCSS operation can also be disabled completely for individual or all channels.

Sub Help Messages

In the box below the editing selection are Sub-Help Messages. These briefly instruct you how to select items, enter channel data, toggle default settings on/off and accept changes. New messages automatically appear pertaining to the edit menu and edit item currently selected. Instructions such as frequency entry format, time-values and

ranges, and keys used to toggle or increment/decrement a setting are given here.

Arrows Select Item [Enter] Accept

Sub-Help Information

Function-Key Help Messages

At the bottom of the screen appears Function-Key selections and their corresponding functions. While the Main Edit Item Screen is selected, F1-Help, F2-Print, F3-Upload, F4-Download, F5-Disk Load, F6-Disk Save, F7-Dump and F10-Exit appear showing options available for this screen. When individual programming selection is done, only three options (F1-Help, F2-Print and F10-Exit) are available.

What to do First

Reading data from the Repeater

If you have the repeater connected to the computer, first download the data from the repeater and save it to disk before doing anything else. Press the ~~F4-Down~~ Load key to do this, and follow the prompts. If an error message is displayed when attempting to download data, check the VPL-1 connection cable and connectors at both the computer and repeater. After downloading the data from the repeater, save it to disk right away as described next in "Saving Data to Disk".

Important Note!

Before entering new channel data from the keyboard, you must either download from the repeater, or from a (valid) data file.

Some EEPROM data, such as I.F. and reference frequencies, is specific to the repeater hardware, and cannot be changed without modifying the circuitry. This data is, however, read-from/written-to the EEPROM. If it does not match the hardware for the repeater to be programmed, the repeater will not operate properly.

Loading Data from Disk

If no repeater is connected to the computer and you just want to view or edit data file already on disk, press F5-Disk Load. A window similar to that below appears, asking for the name of the file to load, which must be the name of a channel data file already on the disk.

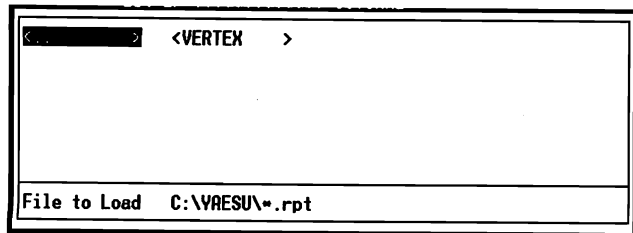

There are no such files provided on the original diskette (you must first download data from the repeater, and save it).

If an error message appears during the loading, either no file could be found on the disk with that name, or the file data was corrupted since the last time it was stored. If the data was corrupted, you will have to build a new file from scratch, or enter another file name. We suggest you erase any corrupted files from the disk to avoid confusion. Just enter DEL filename.rpt Enter from the DOS prompt (substituting the name of your file for *filename*).

Editing Repeater Data

After loading data from a repeater or a data file, you are ready to edit it. Just move the cursor from one field to another, and enter the new data as desired. Refer to the Sub-Help messages and Function-Key functions as you go along, and you can always press the

Listing Data to Screen or Printer

To get a printed copy of a set of data, or to view data without making any changes, press F2-Print from the main screen. To print a displayed page on the printer, if you have a PC keyboard with the Print Screen key also serving as an asterisk key, press Shift and Print Screen together. Otherwise, if you have an enhanced AT keyboard, just press the Print Screen key.

F1-Help key for additional help on each field, as needed. The CTCSS decoder/encoder field (under the Option menu) will allow you to choose tone frequencies from a selection table, shown later.

When you have entered all of the channel and operating data as desired, we recommend that you first save it to disk before uploading it to the repeater.

Saving Data to Disk

You can save data to a disk file at any time by pressing the F6-Disk Save function key. A file list window like that illustrated for Disk Load will appear. Remember that you must save a file if you have just edited data and want to see it again later, but we also suggest you do this whenever you have downloaded from a repeater (so you can restore it if a problem develops later). You will be asked for a file name to save to. This can be any valid DOS file name, but we recommend you choose a name that you will be able to recognize easily later, and be careful not to select a name that already exists.

Sending Data to the Transceiver

After editing data and saving it to a file on disk, you can upload to a repeater, if connected. If the cables are not connected, however, you should press F10 - Exit after making sure you have saved any edited data to a file, and then turn off the computer to connect the cable and repeater. Then turn the computer back on, restart the program, reload the saved file from disk (F5-Disk Load), and then press function key F4-Download and follow the prompts on the screen, pressing the spacebar then starts the download. If an error message is displayed when attempting to download, check your cables and connections carefully. Any key returns you to the Main Menu where you can try again, if necessary. To program another repeater with the same data, you can change the cable connection without having to reboot and start the program again.

Editing Common Data

Environment Data

Environment Data (most of which cannot be changed without changing the hardware), can be viewed by entering the first Main Menu item. These parameters are stored in EEPROM along with the changeable parameters, but they must match the circuitry of the repeater being programmed.

Remember to be careful whenever editing this data as *entering an incorrect IF frequency or Injection Offset will render the repeater non-operational*. To change any of the environment parameters, you must restart the program with the -P switch ("CE8 -P").

- **1st IF** - should be set to 21.6 MHz for VHF versions, 47.9 MHz for UHF. Do not alter this setting unless making hardware changes.
- **L.O. Injection**- selectable upper/lower offset determines the local oscillator injection. Can be changed to improve intermodulation performance in urban areas or high RF environments. Do not alter this setting, as receiver re-alignment is necessary.
- **Channel Steps**- determine the minimum channel step size. Select 5 kHz, 6.25 kHz, 10 kHz, or 12.5 kHz, according to your spacing requirements.
- **Serial Number** - up to 12 digits can be entered here to identify the repeater being programmed. We recommend entering the VXR-5000 identification code found on the side panel of the repeater cabinet for easy future reference.

```

Environment Frequency Timer Setup Option
SERIAL: 000000000000
C:\VAESU\CLONE.RPT

1st IF ..... 21.6MHz
L.O. Injection ..... Low
Channel step ..... 5.0,6.25kHz

Serial Number ..... 000000000000

[Arrows] Select Item [Enter] Accept

F1-Help F2-Print F3-Upload F4-Download F5-DiskLoad F6-DiskSave F7-Dump F10-Exit

```

Repeater Environment Window (using "-P" switch)

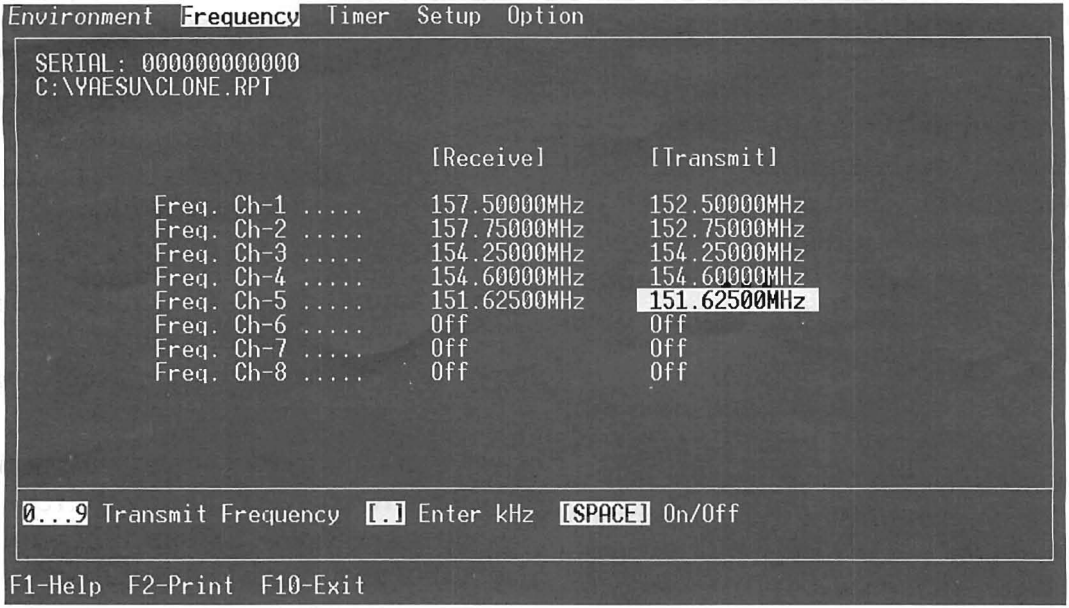

Channel Editor Window

Frequency

Channel data (TX and RX) must be entered individually for channels 1 ~ 8, as shown above. Channels are enabled/disabled by toggling the SPACE bar. Frequencies are entered using the numeric keypad or top-row keys. Up to eight digits can be entered and displayed, however, frequencies will be rounded to the nearest channel-step (as set in the environment window). Confirm that the frequencies entered are within the operating range of the repeater version-type you are programming.

Timer

Time-Out Timer, Hang-Timer and Penalty-Timer settings for both repeater and remote-base operation can be edited in this menu (shown below). These affect overall system operation, and therefore should be configured according to user requirements.

- **Time-Out Timer** - this selects a maximum time period for continuous transmission (1 ~ 60 mins.), or is disabled by pressing the SPACE bar.
- **Hang-Timer** - this controls how long the repeater will remain keyed after a transmitting station's carrier drops (stops transmitting). Hang-Time can be adjusted

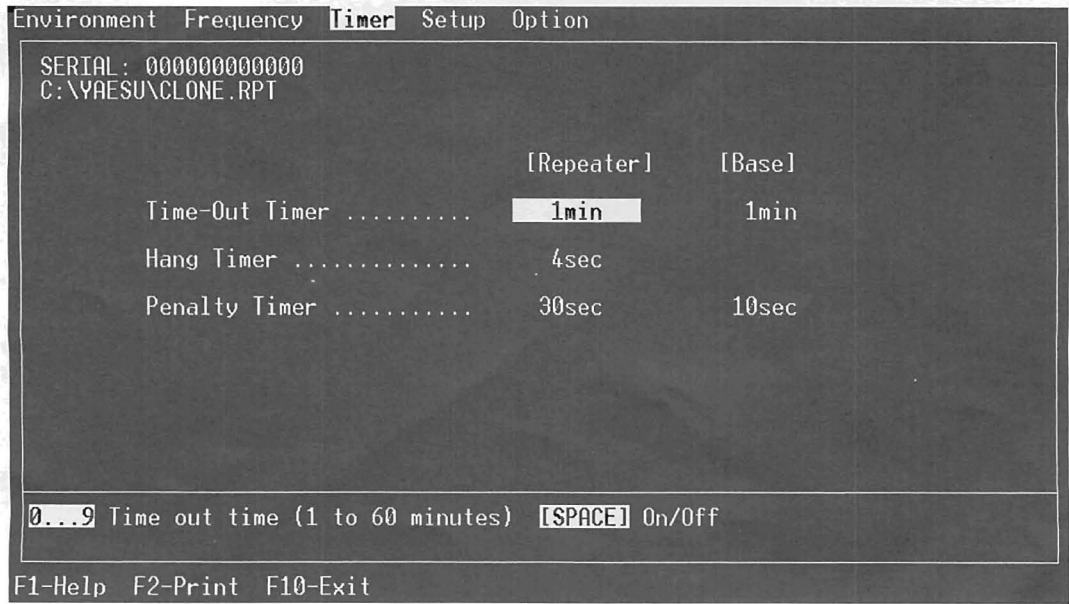

Timer Settings Window

from 1 ~ 60 secs. or disabled by pressing the SPACE bar.

- **Penalty-Time** - this determines the repeater "dead"- or penalty-time after the Time-Out Timer has expired before any station can access the repeater again. Timer is adjustable from 10 ~ 360 seconds.

Set Up

The following repeater system operation can be programmed according to user requirements from this menu:

- **Mode** - Use the SPACE bar to toggle between Simplex or Duplex operation.
- **DC RF PWR LVL** - When operation shifts to auxiliary DC power source, selecting low power will result in TX power automatically switching to low power to extend operation time under battery power.

Normal selection retains TX power at the default power setting (as set in the alignment mode).

- **Hi Temp Pwr Red** - This feature automatically monitors repeater TX power amplifier temperature, and, if safe operating temperatures are exceeded, reduces TX output power (or disables the transmitter) to prevent damage from over-heating.
- **Alarm Beeper** - Enables/disables the Alarm beep tone as the Time-Out Timer is about to expire.
- **Hang-Time Audio Sel** - Determines if channel audio (noise) will be heard during TX hang-time (repeater keyed with carrier not present). With *Quiet* selected, receiver audio will remain squelched, *Noise-Out* enables open-channel noise (muted -10 dB) to be heard. Use the SPACE bar to make a selection.

```

Environment  Frequency  Timer  Setup  Option
-----
SERIAL: 000000000000
C:\YAESU\CLONE.RPT

Mode ..... Simplex
DC RF PWR LVL ..... Normal
Hi Temp Pwr Red. .... Enabled
Alarm Beeper ..... Enabled
Hang Time Audio Sel. .. Noise Out

[Arrows] Select Item  [Enter] Accept

F1-Help F2-Print F3-Upload F4-Download F5-DiskLoad F6-DiskSave F7-Dump F10-Exit

```

Repeater System Configuration Setup

Option

CTCSS tone encode/decode options are selected in this menu. Toggling the SPACE bar enables/disables the encoder/decoder for each channel. CTCSS tone frequencies can then be entered numerically (if the exact frequency is already known), or else selected from a standard tone table by pressing Enter and using the ↔ arrow keys to select the desired EIA-standard tone.

[Decode]		[Encode]	
Tone Select			
67.0	69.3	71.9	74.4
77.0	79.7	82.5	85.4
88.5	91.5	94.8	97.4
100.0	103.5	107.2	110.9
114.8	118.8	123.0	127.3
131.8	136.5	141.3	146.2
151.4	156.7	162.2	167.9
173.8	179.9	186.2	192.8
203.5	210.7	218.1	225.7
233.6	241.8	250.3	

CTCSS Tone Selection Window

This completes operational and programming information for the CLONE mode, for repeater internal system alignment and monitoring I/O (input/output) status, proceed with the ALIGNMENT mode covered next.

```

Environment Frequency Timer Setup Option
SERIAL: 000000000000
C:\YAESU\CLONE.RPT

                [Decode]      [Encode]
CTCSS Ch-1 ..... 103.5Hz    103.5Hz
CTCSS Ch-2 ..... 141.3Hz    141.3Hz
CTCSS Ch-3 .....  67.0Hz    250.3Hz
CTCSS Ch-4 .....  Off         Off
CTCSS Ch-5 .....  Off         Off
CTCSS Ch-6 .....  91.5Hz     91.5Hz
CTCSS Ch-7 .....  Off         Off
CTCSS Ch-8 .....  Off         Off

Arrows Select Item [Enter] Accept

F1-Help F2-Print F3-Upload F4-Download F5-DiskLoad F6-DiskSave F7-Dump F10-Exit
    
```

Option - CTCSS Entry Window

Alignment Mode

This mode is selectable from the introductory screen as selected with the “-A” switch from DOS (type A: CE8 -A Enter), forgetting the “-A” switch permits opening the CLONE mode only. The Alignment Mode enables you to view current repeater I/O status and adjust repeater output power level during battery operation. Two items are selectable here; Status and Alignment (see the full-screen display on the bottom of the next page).

Repeater System Status Display

This window displays three areas: Alarm, Logic In and Logic Out. Note that these parameters cannot be modified, only viewed. Along the bottom of the screen, Function Key selections appear as before. After pressing Enter, a different function key submenu will appear, as shown below.

F1-Help F2-Print F3-PTT F4-Read F10-Exit

Alignment Mode Sub-Menu

To monitor the present I/O status of the repeater, press F4. An “Accessing Repeater” message appears briefly as the I/O data is loaded, then all parameters are displayed. This feature is useful for network monitoring, confirming system programming changes, or to assist in troubleshooting in the event that an repeater system alarm is received.

Repeater System Status Parameters

A brief explanation of system I/O parameters are explained below:

VXR-5000 System Parameters		
Parameter	Indication	Comment
[Alarm]		
Tx Unlock	Normal / Unlock	TX PLL state
Rx Unlock	Normal / Unlock	RX PLL state
[Logic In]		
BASE	L - base H - rptr	Mode of Operation from pin 13, BASE
PTT	L - tx H - rx	TX keyed from pin 12, PTT
RX MUTE	L - muted H - unmuted	Line audio from pin 19, RX MUTE
TONE OFF	L - off H - on	CTCSS Audio Off from pin 17, TONE OFF
NSQ OFF	L - off H - on	Noise Squelch Off from pin 10, NSQ OFF
SQ LOW	L - low H - high	Squelch Status from pin 20, SQL LOW
HI TEMP	L - reduced tx power H - normal tx power	PA Unit High Temp from Thermal Sensor
BATT	L - Battery Operation H - AC Mains Operation	Aux. Battery Oper.
REMOTE	1 - 8	Channel of Operation from pins 21-23, REMOTE D0, D1, D2
[Logic Out]		
TONE DET	L - active H - none	CTCSS Tone Receive
NSQ DET	L - low H - high	Noise Squelch
COAXIAL SW	L - relay energized H - relay de-energized	Antenna Relay from pin 9, COAX SW
TX CNTL	L - low H - high	Logic Output from pin 18, TX

```

Status Alignment
SERIAL: 000000000000 <PTT Off>
C:\YAESU\ADJUST.RPT

=== Repeater Status ===

[Alarm]                                [Logic In]                                [Logic Out]
Tx Unlock .....                       BASE .....                               TONE DET .....
Rx Unlock .....                       PTT .....                               NSQ DET .....
                                           RX MUTE .....                           COAXIAL SW ...
                                           TONE OFF .....                          TX CNTL .....
                                           NSQ OFF .....
                                           SQ LOW .....
                                           HI TEMP .....
                                           BATT .....
                                           REMOTE .....

Arrows Select Item [Enter] Accept

F1-Help F2-Print F3-Upload F4-Download F5-DiskLoad F6-DiskSave F7-Dump F10-Exit
    
```

Repeater I/O Status Window

Power Alignment

When enabled from the CLONE mode, transmitter RF output automatically switches to a reduced level as soon as operation switches to DC (battery) power. In addition, continued transmit capability during a high-temperature condition (HI TEMP) at reduced power is possible if this setting is enabled. In either case, the reduced RF power level is set in the alignment mode.

From this window you can view or adjust reduced RF power output level as described above, and the normal RF output power level. Two bargraphs show each RF power output for comparison, along with a discrete power level calibration value (0-255) displayed above the graph (see display at page bottom).

To change either level, press Enter to bring up the function-key sub-menu.

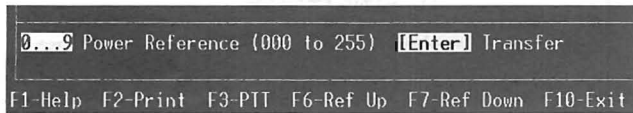

Power Adjust Sub-Menu

Use the F6 & F7 keys to adjust the desired power level, or else you can enter a discrete level from 0-255 using the keyboard and pressing Enter.

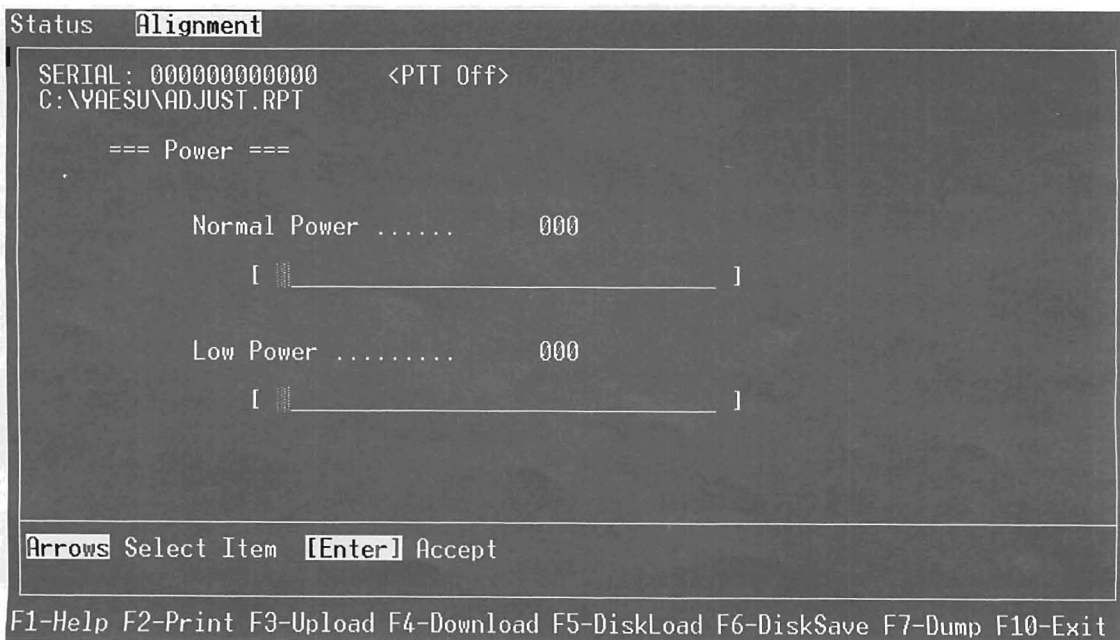

Alignment Power Settings Window

Battery Operation

When under battery back-up power, repeater operational time is influenced by three factors:

1. Current capacity of the storage battery (rated in Amp-Hours)
2. Preset RF power output level for DC operation.
3. TX duty cycle

To maximize repeater operational time, we suggest the following advice:

Utilize a storage battery with a rated load capacity of at least 50-Ah or more as a minimum back-up supply.

Set the reduced RF power level for DC operation and during HI TEMP conditions to approximately half (12 W) or less for conservative operation.

If possible, inform repeater users that the system is under a back-up power source, and to limit non-essential communications to conserve battery life.

To manually key the transmitter, press F3. You can do this now, with a wattmeter connected to the **TX ANT** jack to check actual power with software reference level. You will also need to do this as part of the transmitter alignment step in the *Alignment* Chapter, covered later.

Alignment

The VXR-5000 has been factory aligned for the specified performance across the entire operating frequency range. Realignment should not be necessary except in the event of a component failure. All component replacement and service should only be performed by an authorized Yaesu service representative, or the warranty policy may be voided.

Required test equipment

- IBM PC/compatible computer
- Yaesu CE-8 Channel Programming Diskette and VPL-1 connection cable.
- RF Signal Generator with calibrated output level at 200 MHz.
- Deviation Meter (linear detector)
- Oscilloscope
- AF millivoltmeter
- SINAD Meter
- In-line Wattmeter with 5% accuracy at 200 MHz.
- Regulated DC Power Supply adjustable from 10 -17 VDC, 15 A.
- 50-Ohm, non-reactive Dummy Load: 100 W @ 200 MHz.
- Frequency Counter ± 0.2 ppm accuracy at 200 MHz
- AF Signal Generator
- DC Voltmeter: high input impedance
- Spectrum Analyzer
- VHF Sampling Coupler

Before alignment, connect the repeater and PC to the VPL-1 connection cable as described in the Channel Programming Chapter, and download the EEPROM data from the transceiver to the computer. Then store this data in a file so that it can be uploaded when alignment is finished.

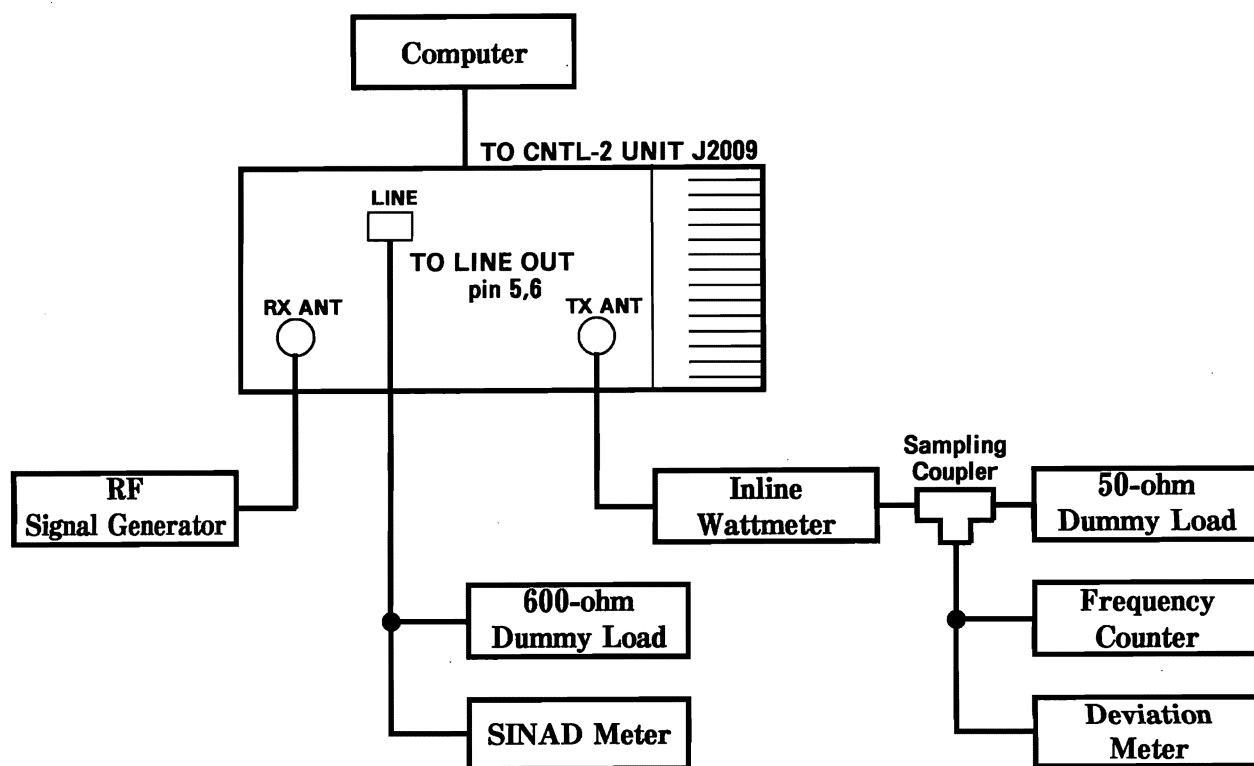

Alignment Setup

Note!

To start the CE-8 software in the *Alignment Mode*, use the `-a` command line switch. eg. `C:>ce8 -a (enter)`

Next, using the CE-8 Channel Editor and referring to the table below, program channels 1, 2 and 3 according to version type. Set these three channels to simplex and, and turn off any tone settings for these channels. Upload this data to the repeater.

VER.	Low Ch.	Center Ch.	High Ch.	Frequency Range
A	140.1	141.1	142.1	134 - 146 MHz
B	152.1	153.1	154.1	146 - 160 MHz
BS-1	161.1	162.1	163.1	156 - 168 MHz
C	168.1	169.1	170.1	164 - 174 MHz

note: above channels are the band-center for each version type
maximum receiver spread w/o degradation is 2 MHz

Note: When finished with alignment, make certain to reload the original channel data from disk, and upload it back to the repeater.

Before beginning alignment, preset the following controls and switches as follows.

- VR2002-VR2005 & VR2006: center, 12 o'clock position

- L4002, L4003, L4005, L4011, L4013, L4015
T4001, T4002: flush with the top of coil form
- VR7071: centered
- VR4001: fully clockwise
- S2003: NOR
- S2005: INT
- S2001 & S2004: LOW
- S2006: NOR
- pin 10 of ACC connector to GND

Power Supply Voltage Alignment

- Connect the positive (+) lead of the DC voltmeter to P7001 on the REG Unit, and negative (-) to P7002, then adjust VR7001 for 13.8 ± 0.1 VDC.

Transmitter

- Set up the test equipment as shown below for TX alignment. Adjust the supply voltage to 13.8 VDC (as above) for all steps.

VCV Adjustment

- Select the high band-edge channel, connect the DC voltmeter between VCV land and GND on the TX Unit. Then key the repeater and adjust TC5001 on the TX VCO Unit for 7.5 VDC.
- Connect a frequency counter to the **TX ANT** jack via a sampling coupler (attenu-

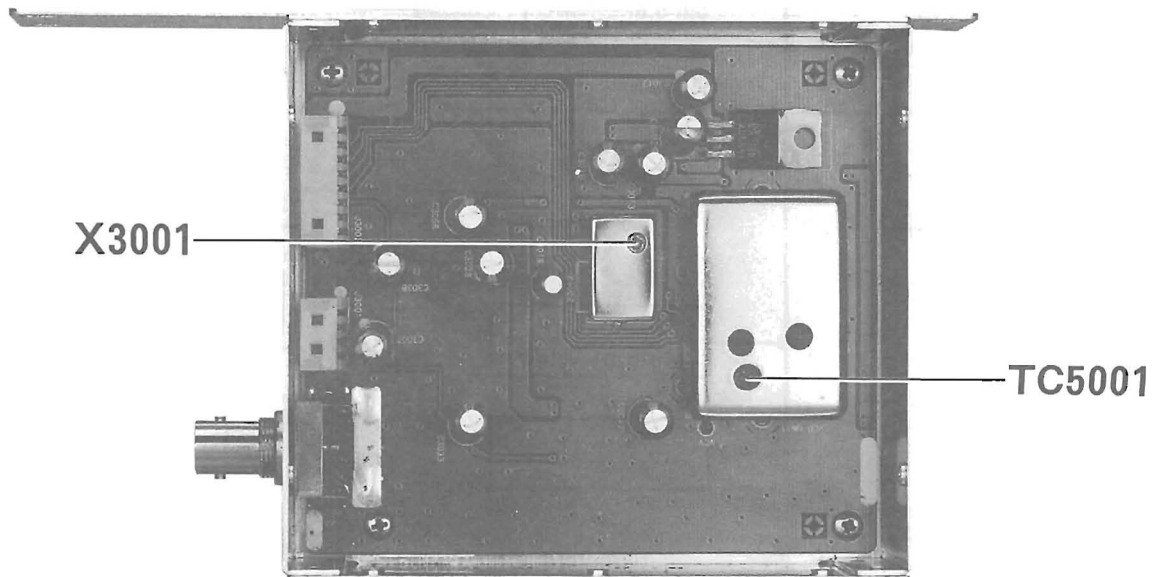

TX Alignment Points

ator pad), key the transmitter and adjust X3001, so that the TX frequency is within ± 150 Hz of the programmed TX frequency.

RX Unit

Set up the test equipment as shown here for receiver alignment.

VCV Adjustment

- Select the highest receive frequency, then connect a DC voltmeter between the VCV land and GND on the RX Unit. Adjust TC5501 on the RX VCO Unit for 7.5 VDC.

Sensitivity Adjust

- Inject a 0 dBu signal modulated with 1 kHz tone at 20 mV RMS and 5 kHz deviation to the RX ANT connector.
- Adjust L4002, L4003, L4005, L4011, L4013 and L4015 for maximum SINAD indication. Confirm that the 12 SINAD level does not exceed $.35 \mu\text{V}$ on the low, mid and high receive frequencies.
- Increase SG output to +40 dBu, then adjust T4001 and T4002 for minimum distortion level indicated on the SINAD meter.

TX Output Power

- Connect a dummy load wattmeter to the **TX ANT** connector.

Full Power Set

- Connect the VPL-1 connection cable to J2008 on CNTL Unit 2, then load the CE-8 programming software. Recall the alignment adjustment file, and press the return key. Key the repeater and press the function key indicated in the program for an indication of 25 watts (± 0.5 watt) on the wattmeter.

Low Power Set

- Repeat the above procedure for an indication of 12.5 Watts (± 0.5 watts) on the wattmeter.
- Press the F10 key to exit the adjustment mode, then press F4 to save the settings to memory. Disconnect the VPL-1 cable.

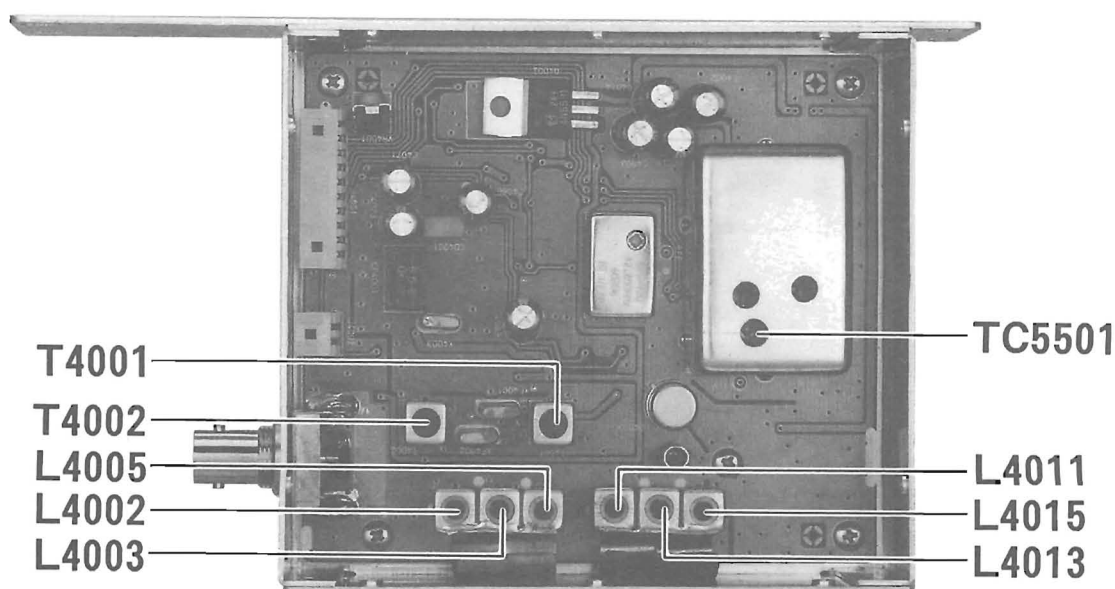

RX Unit Alignment Points

Repeater Mode

Squelch Adjust

- First ensure the DUPLEX mode of operation is enabled via CE-8 programming.
- Inject a standard deviation 0 dB μ signal into the **RX ANT** jack. Adjust VR4001 on the RX Unit to the point where the TX is activated.

Deviation Adjustment

- Inject a 1-kHz, 40 dBu 3-kHz signal to the **RX ANT** jack, and adjust VR2005 for 3.0 kHz (± 0.1 kHz) TX deviation.

Base Mode

Note: When making Base Mode adjustments, connect pin 13 of the **ACC** jack to GND.

Audio Level Adjust

- Connect the SG to the **RX ANT** jack and adjust the SG output level to 40 dBu and standard deviation level. Adjust VR2005 for -10 dBm ± 0.1 dBm line out audio level.

Deviation Adjustment

- Connect an audio signal generator to line-in jack, then adjust generator output level to 10 dBm @ 1 kHz. Adjust VR2002 for 3.0 kHz ± 0.1 kHz deviation.

Chip Component Information

The diagrams below indicate some of the distinguishing features of common chip components.

Ceramic Capacitors

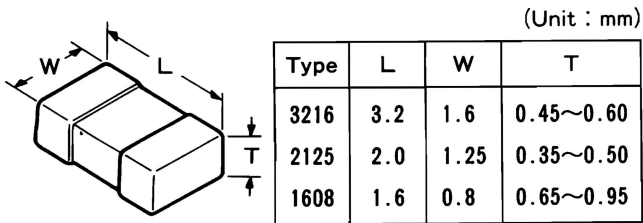

Tantalum Capacitors

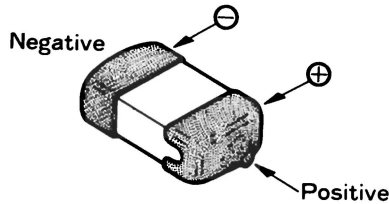

Polarized, Unmarked
(determine value from layout and Parts List)

Type RMC 1/10W,1/16W

Marking* 100,222,473.....

473		
Ten unit	One unit	Multiplier code
0	0	10 ⁰
1	1	10 ¹
2	2	10 ²
3	3	10 ³
4	4	10 ⁴
5	5	10 ⁵
6	6	10 ⁶
7	7	10 ⁷
8	8	10 ⁸
9	9	10 ⁹

Examples :

100 = 10Ω

222 = 2.2kΩ

473 = 47kΩ

Resistors

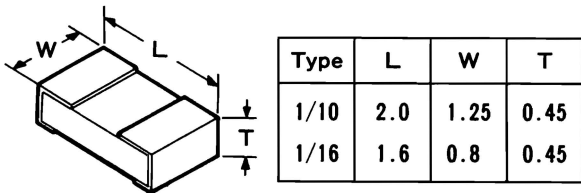

Indicated Letters

1 2 3 4
5 6 7 8
9 0 .

Replacing Chip Components

Chip components are installed at the factory by a series of robots. The first one places a spot of adhesive resin at the location where each part is to be installed, and later robots handle and place parts using vacuum suction.

For single-sided boards, solder paste is applied to the board and then baked to harden the resin and flow the solder. For double-sided boards, no solder paste is applied, but the board is baked (or exposed to UV light) to cure the resin before dip-soldering.

In our laboratories and service shops, small quantities of chip components are mounted manually by applying a spot of resin, placing with tweezers, and then soldering by very small dual streams of hot air (without physical contact during soldering). We remove the parts by first removing solder using a vacuum suction iron, which applies a light, steady vacuum at the iron tip, and then breaking the adhesive with tweezers.

The special vacuum soldering/de-soldering equipment is recommended if you expect to do a lot of chip replacements. Otherwise, it is usually possible to remove and replace chip components with only a tapered, temperature controlled soldering iron, a set of tweezers and braided copper solder wick. Soldering iron temperature should be below 280°C (536°F).

Precautions for Chip Replacement

- ✗ Do not disconnect a chip forcefully, or the foil pattern may peel off the board.
- ✗ Never re-use a chip component. Dispose of all removed chip components immediately to avoid mixing with new parts.
- ✗ Limit soldering time to 3 seconds or less to avoid damaging the component and board.

Removing Chip Components

- Remove the solder at each joint, one joint at a time, using solder wick wetted with non-acidic flux as shown below. Avoid applying pressure, and do not attempt to remove the tinning from the chip's electrode.

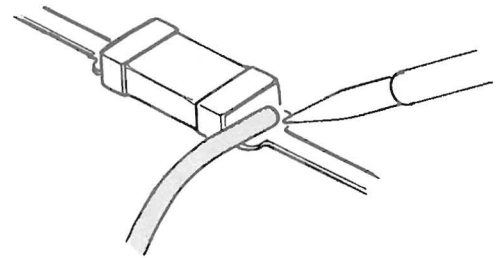

- Grasp the chip on both sides with tweezers, and gently twist the tweezers back and forth (to break the adhesive bond) while alternately heating each electrode. Be careful to avoid peeling the foil traces from the board. Dispose of the chip when removed.

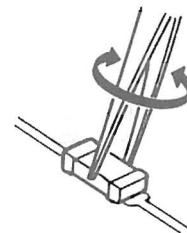

- After removing the chip, use the copper braid and soldering iron to wick away any excess solder and smooth the land for installation of the replacement part.

Installing a Replacement Chip

As the value of some chip components is not indicated on the body of the chip, be careful to get the right part for replacement.

- Apply a small amount of solder to the land on one side where the chip is to be installed. Avoid using too much solder, which may cause bridging (shorting to other parts).

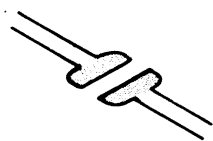

- Hold the chip with tweezers in the desired position, and apply the soldering iron with a motion line that is indicated by the arrow in the diagram below. Do not apply heat for more than 3 seconds.

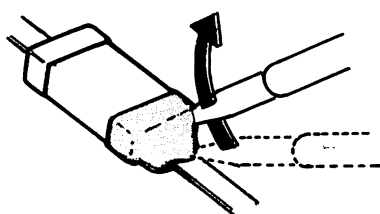

- Remove the tweezers and solder the electrode on the other side in the manner just described.

Notes:

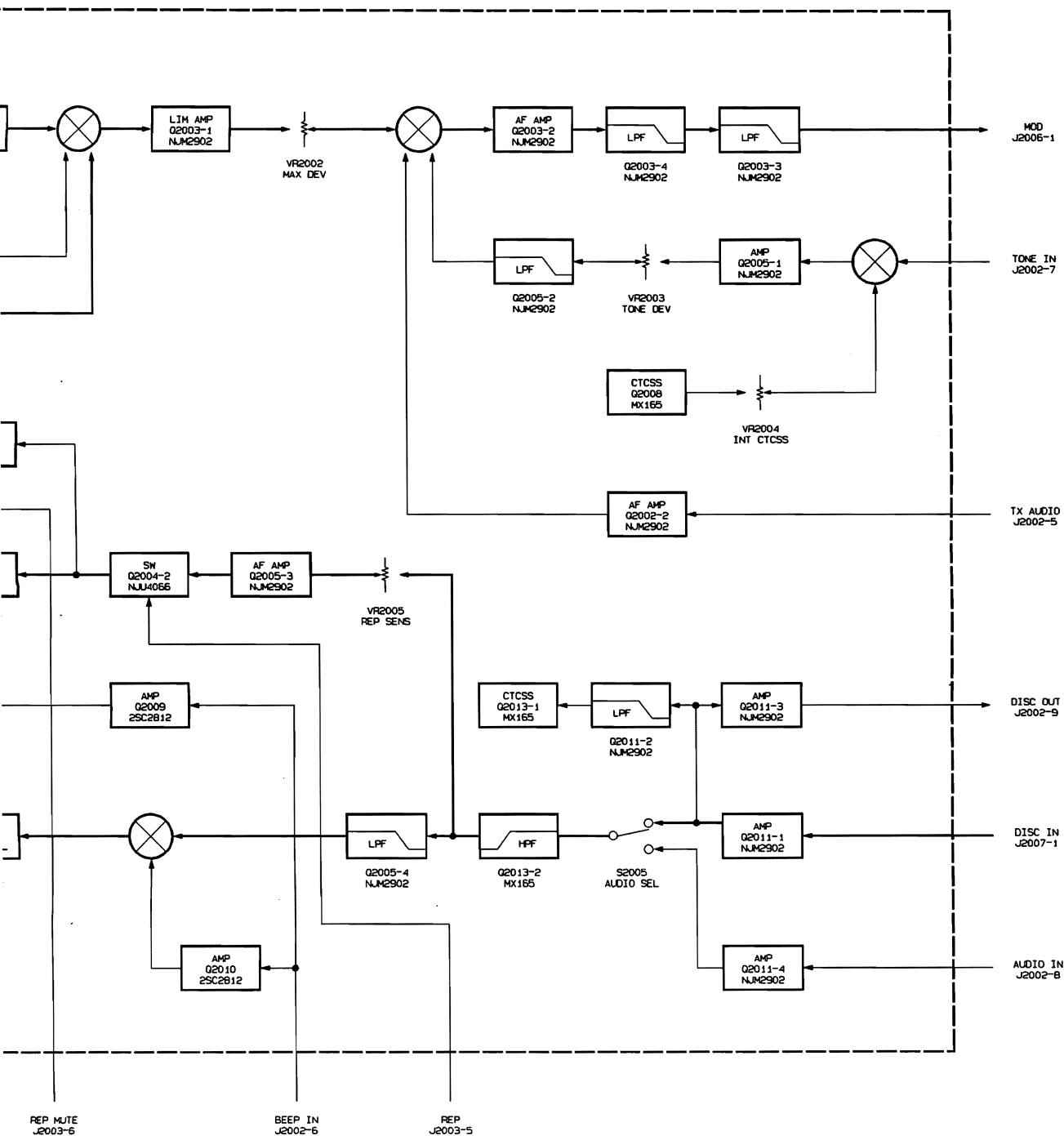

Block Diagram

A:134-147
B:146-160
BS:156-168
C:164-174

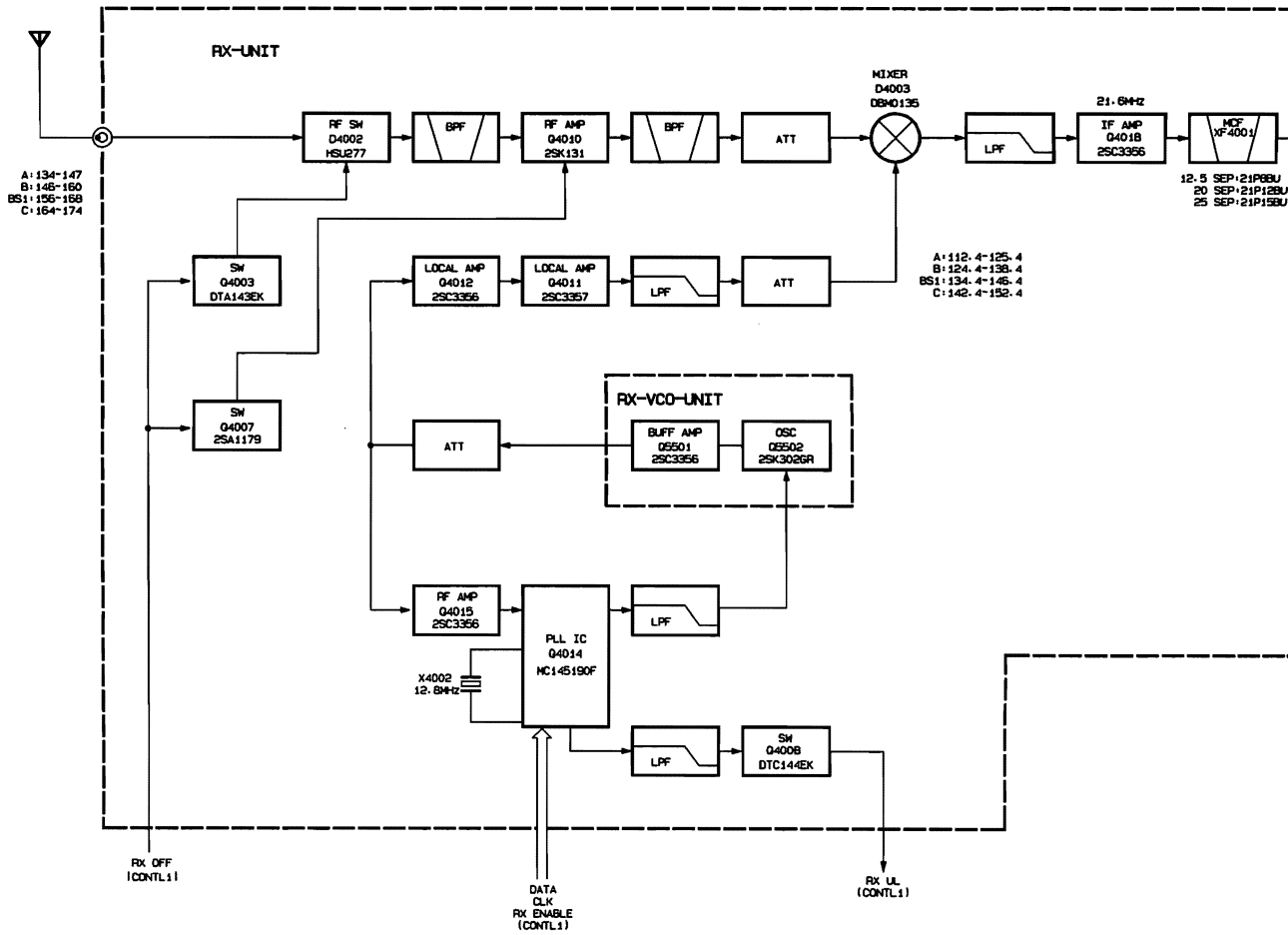
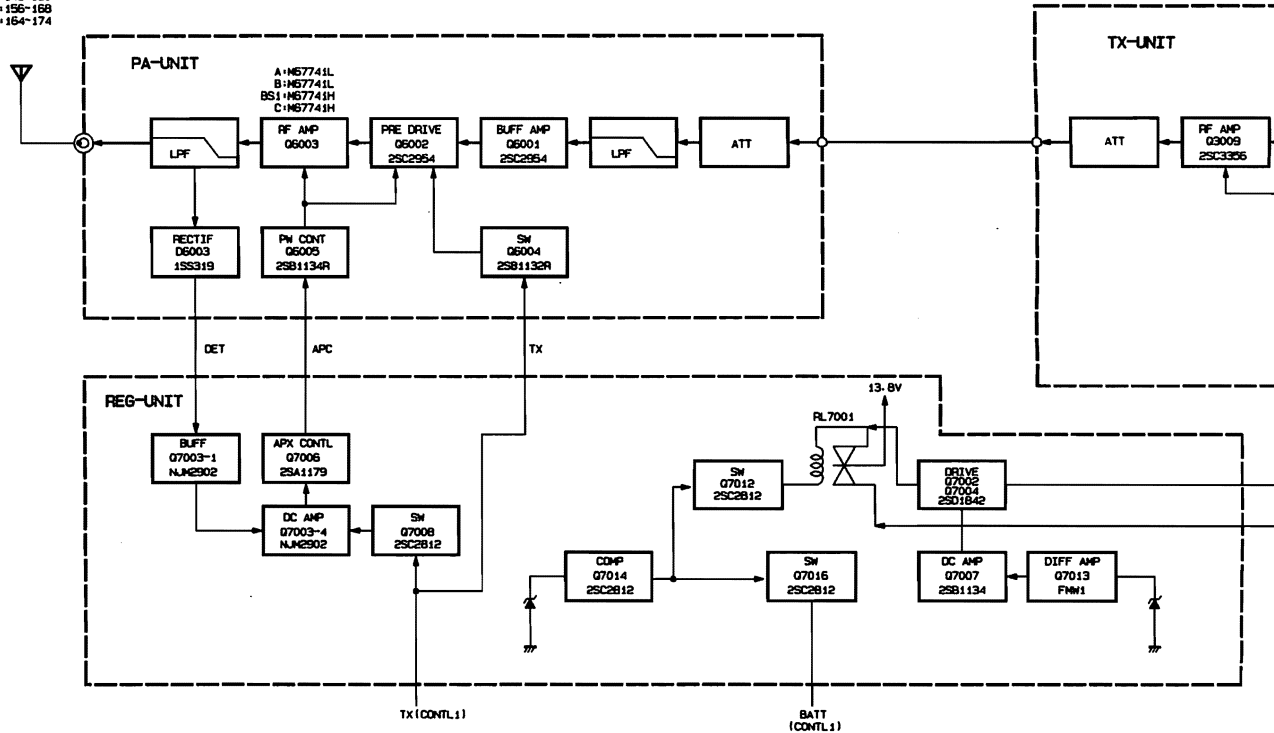

A:134-147
B:146-160
BS:156-168
C:164-174

A:112.4-125.4
B:124.4-138.4
BS:134.4-146.4
C:142.4-152.4

12.5 SEP-21P8BU
20 SEP-21P15BU
25 SEP-21P15BU

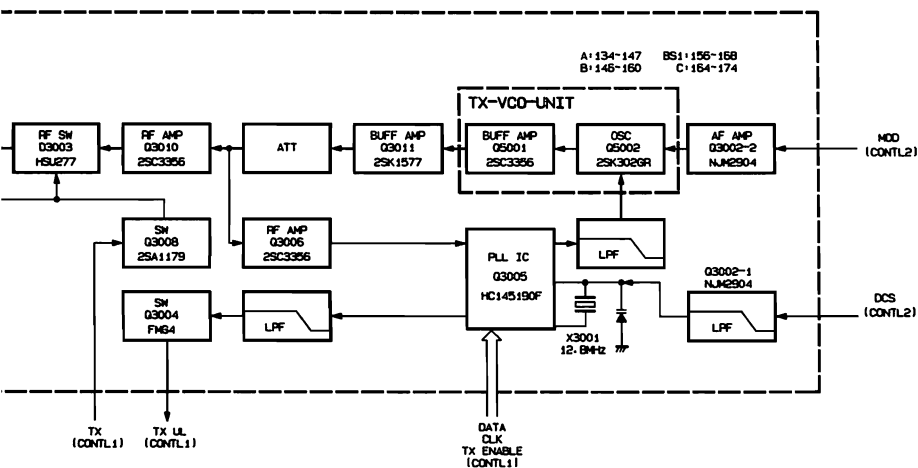

— V+ (CAPA)
 — B+ (EXT BAT.)

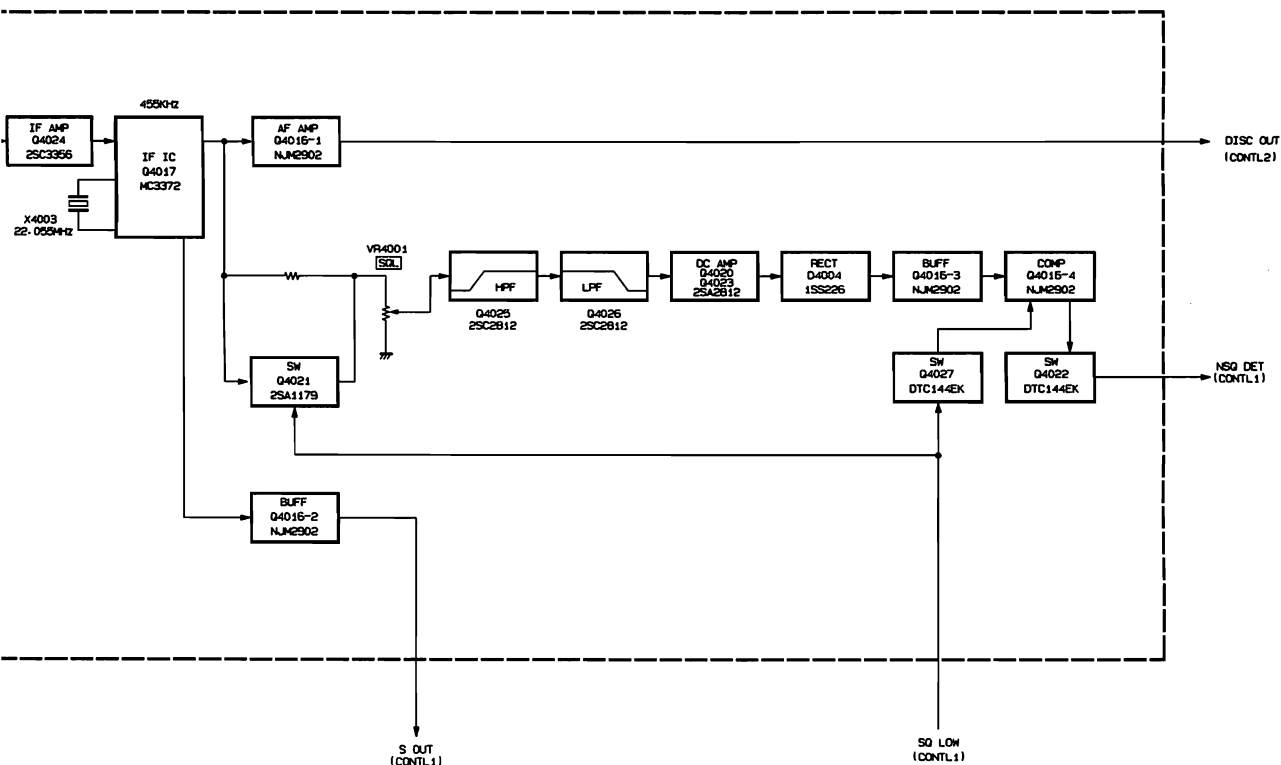

AF Block Diagram

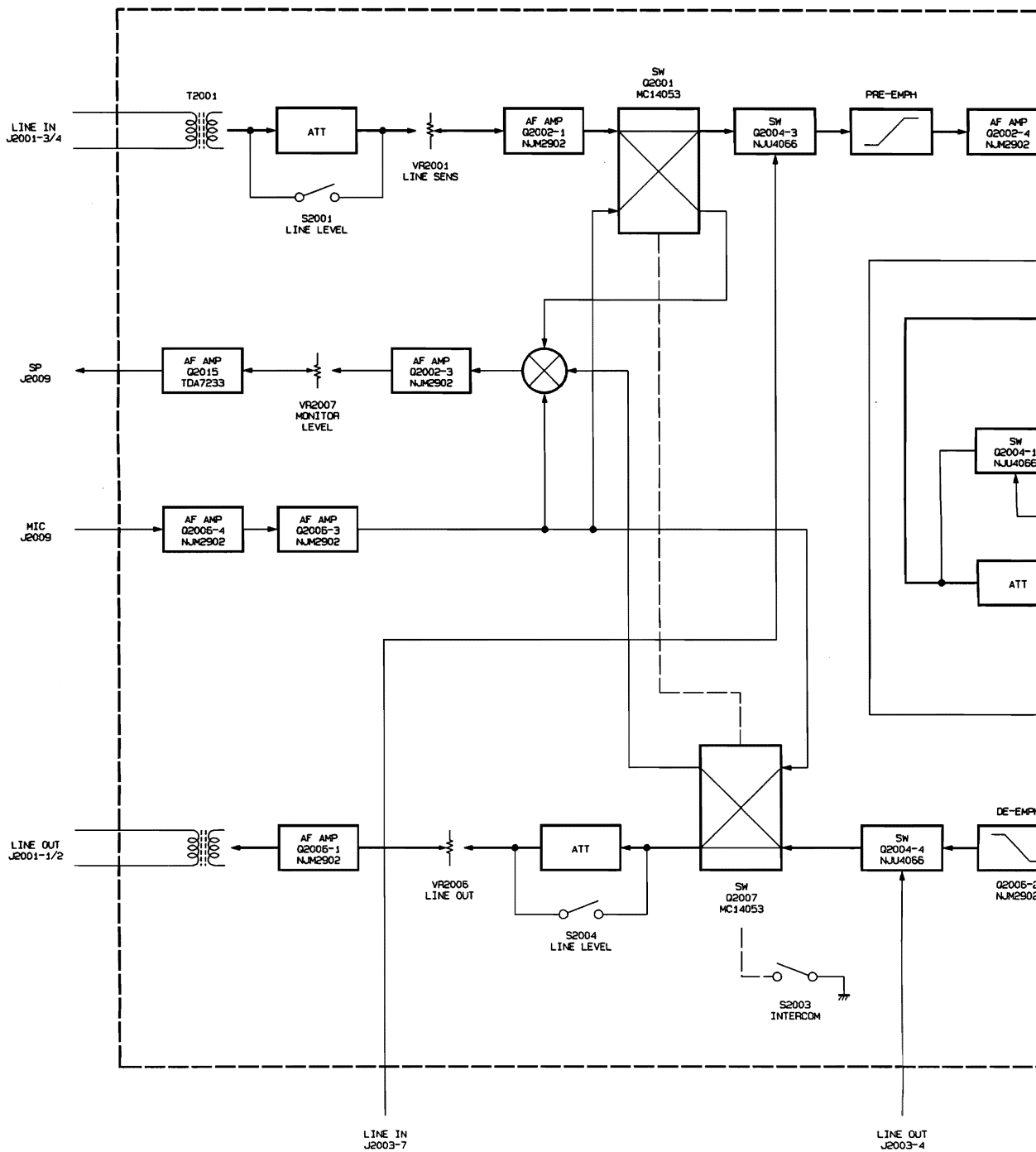

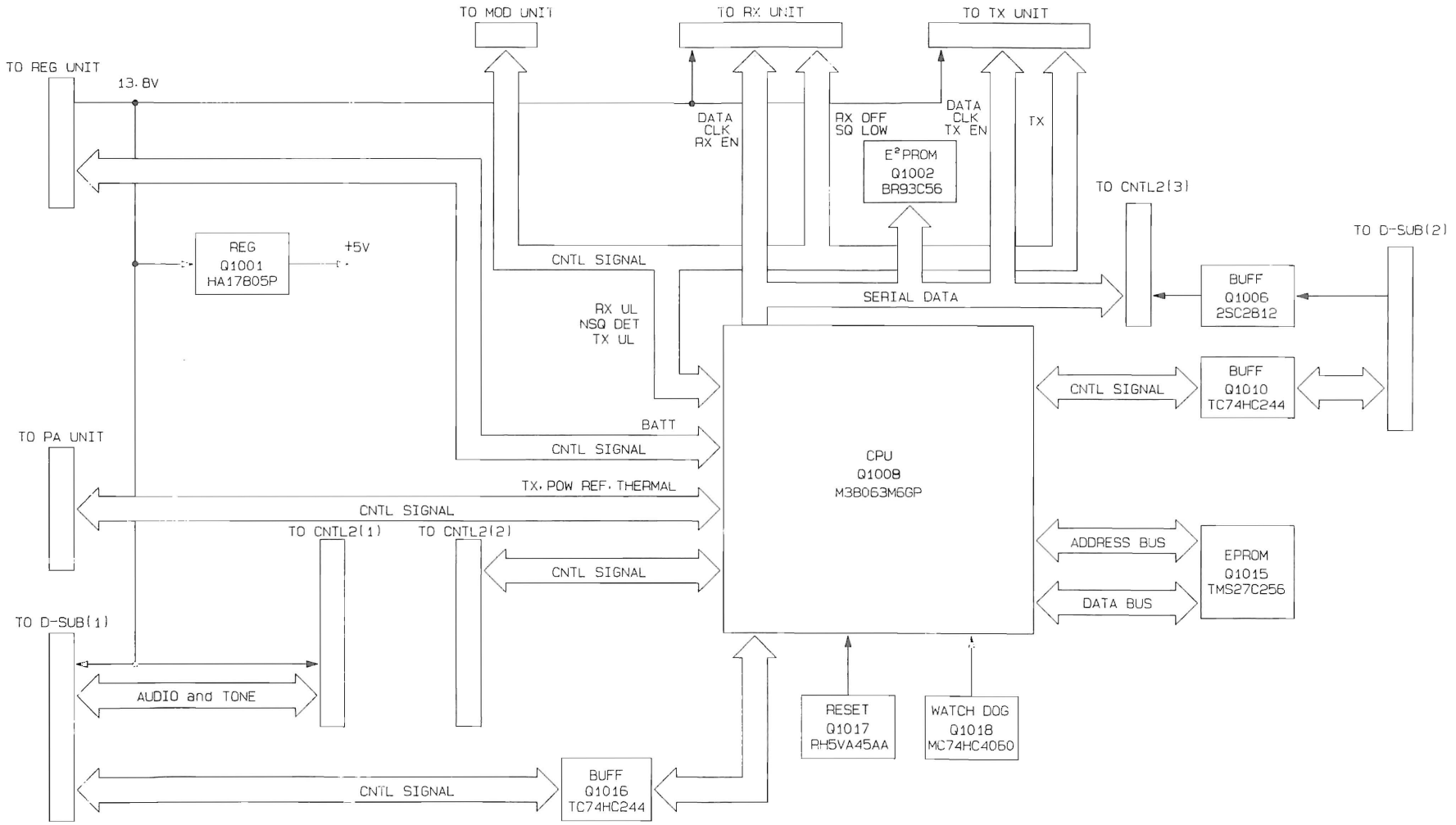

CNTL1 Block Diagram

CONNECTION-DIAGRAM

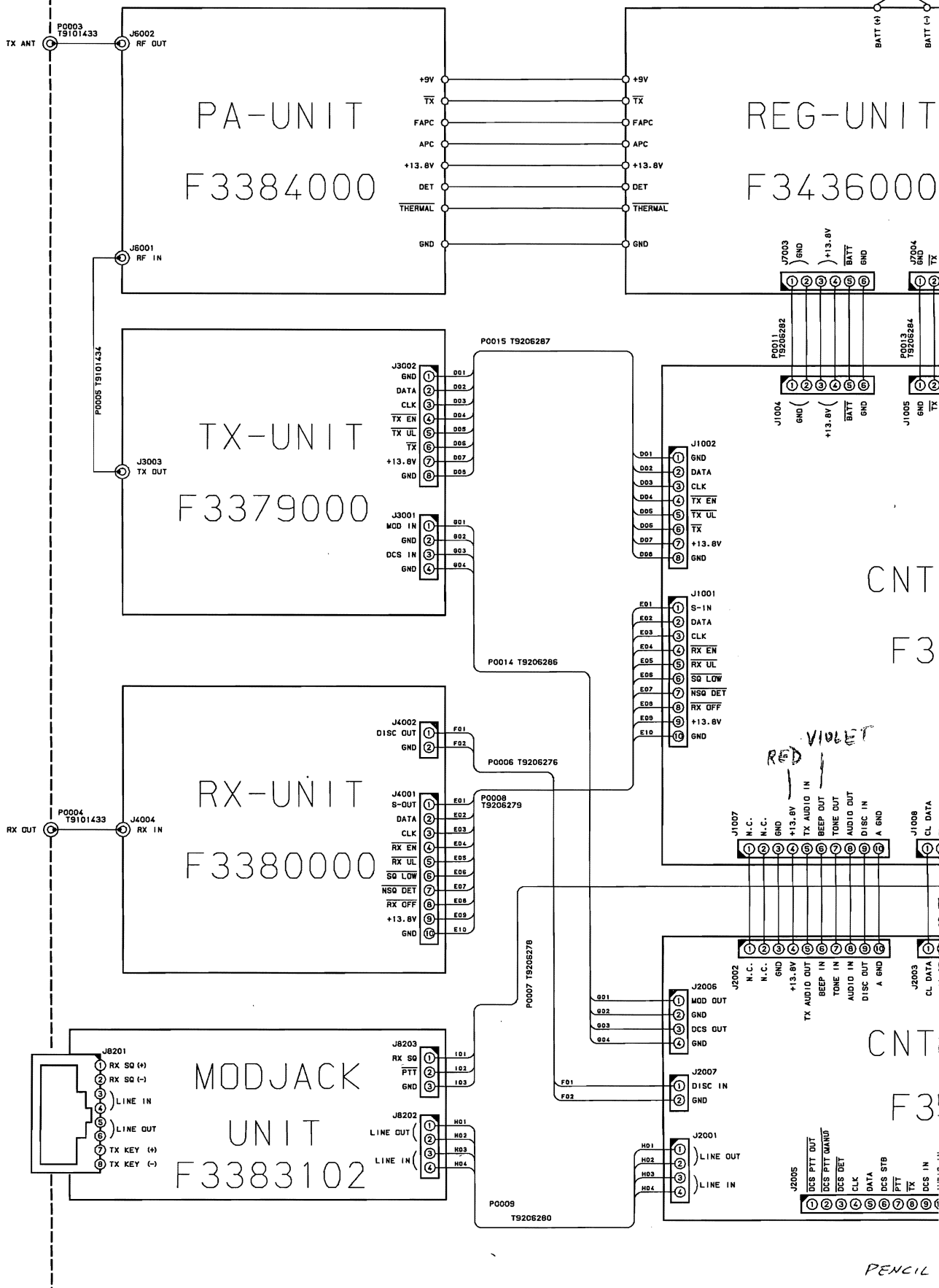

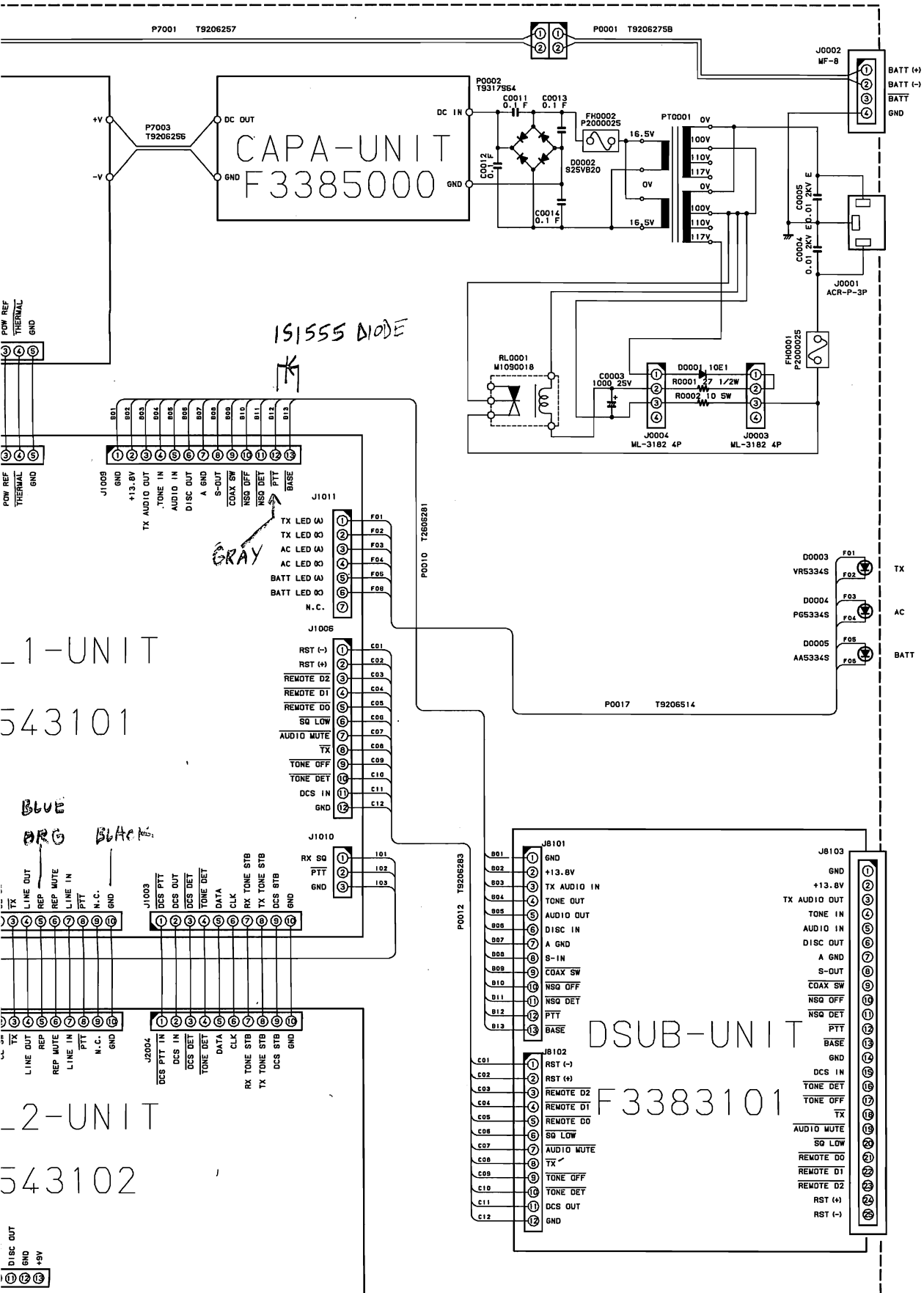

1S1555 DIODE

GRAY

1-UNIT
543101

BLUE
ORG
BLACK

2-UNIT
543102

DSUB-UNIT
F3383101

INDICATES ID-8 CONNECTIONS - 6/98

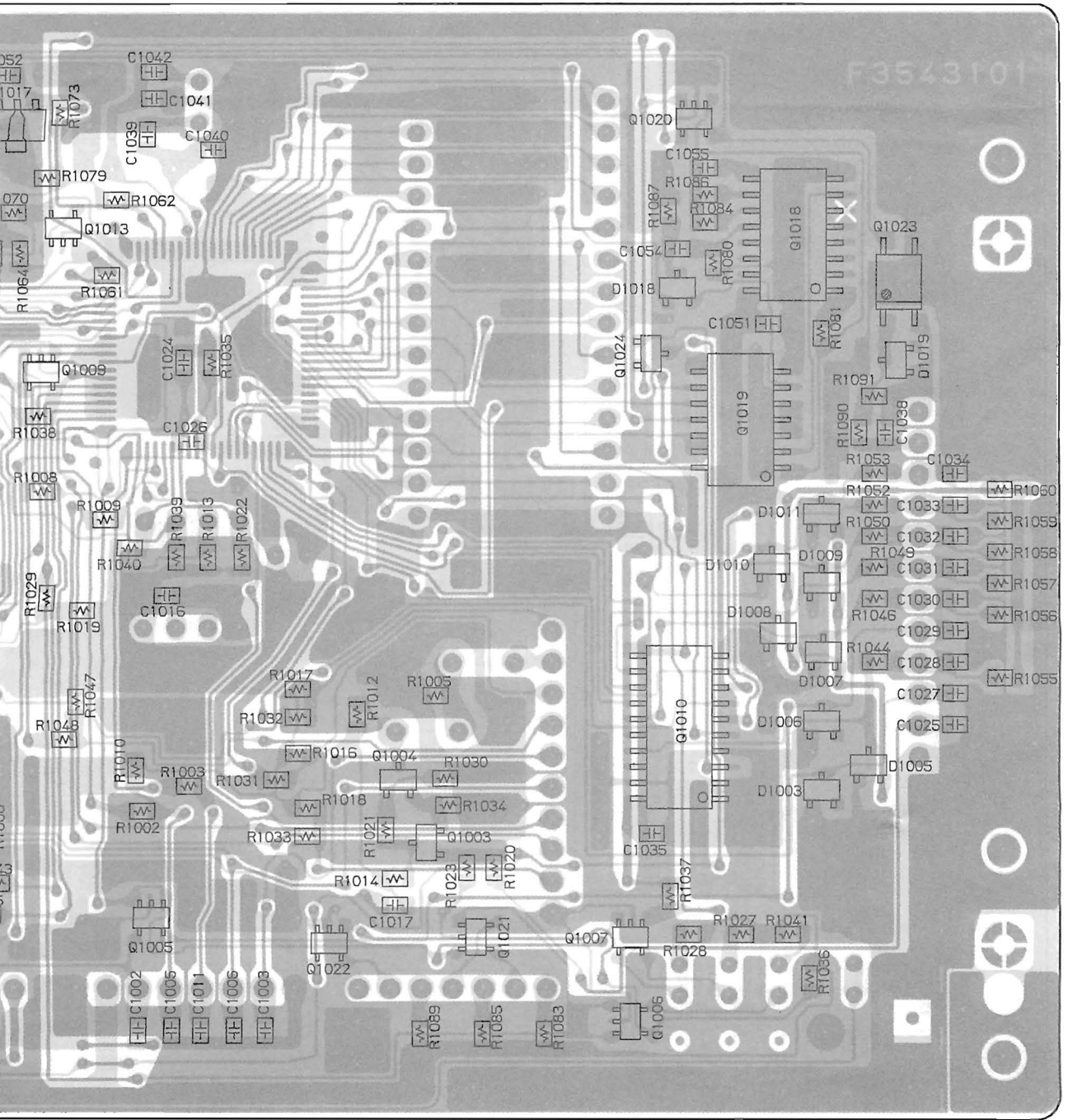
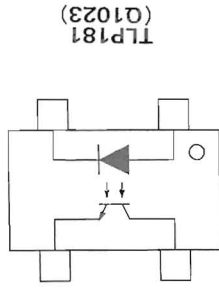
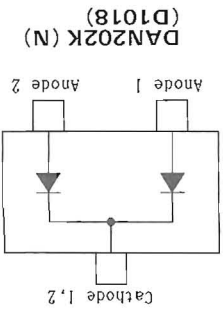
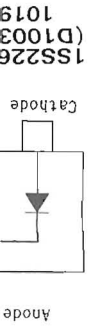

Parts Layout

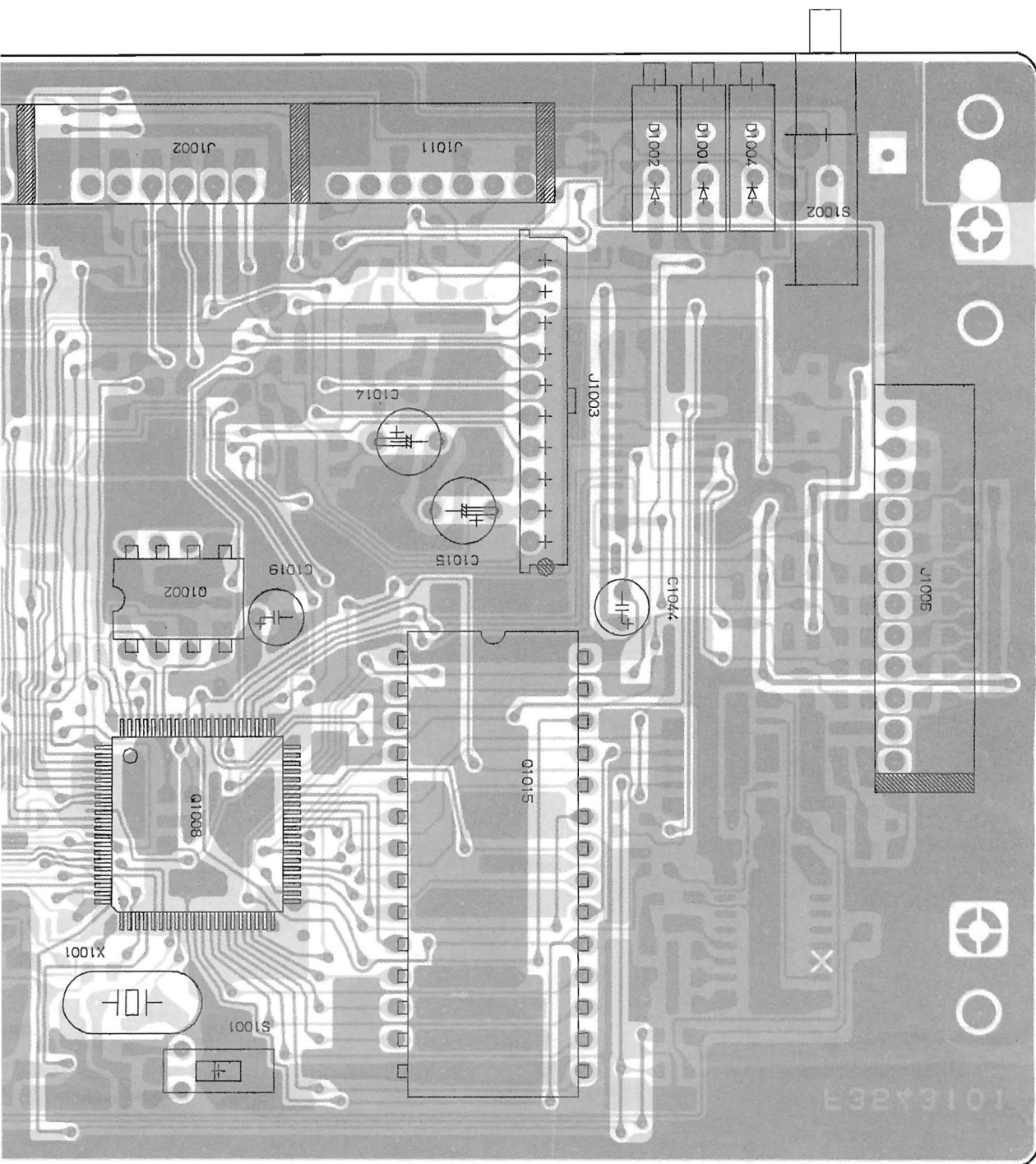

obverse view of component side

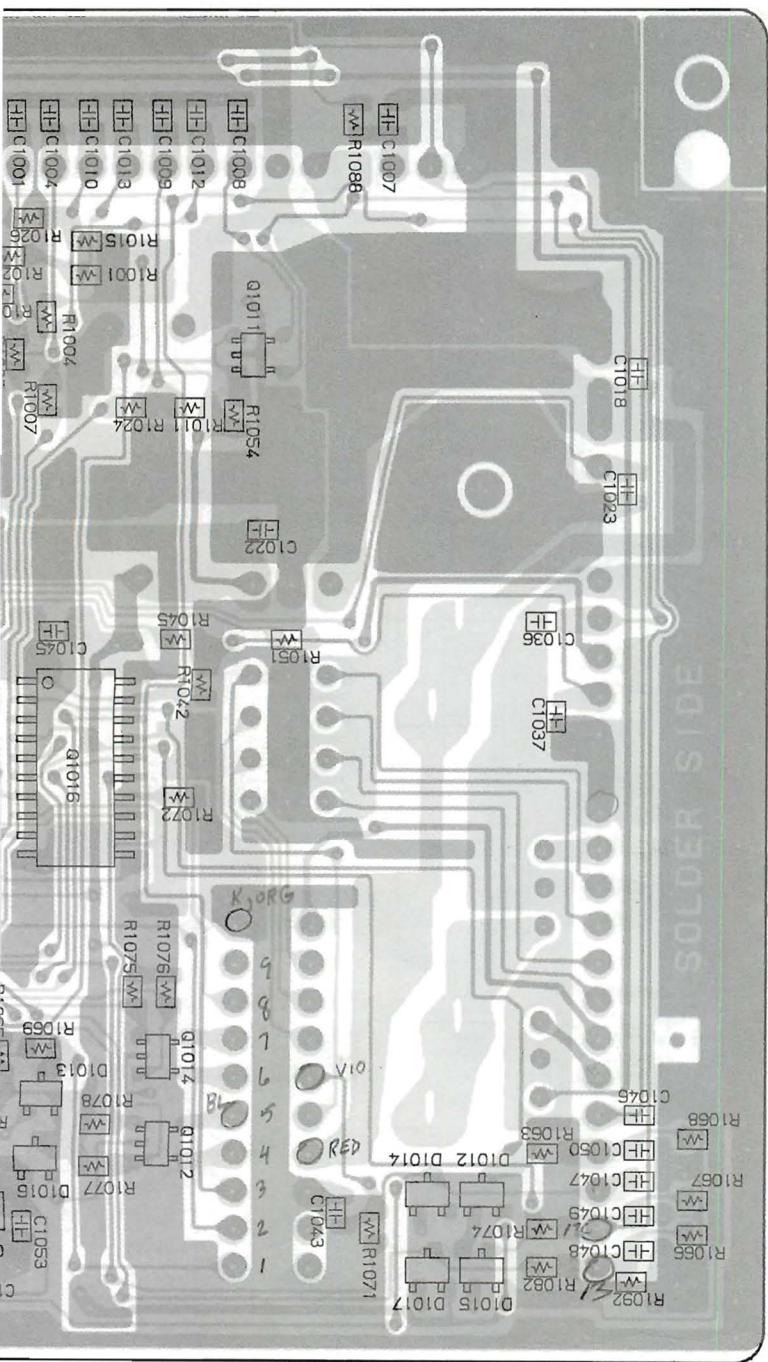

J1008 J1007

J1009

obverse view of chip side

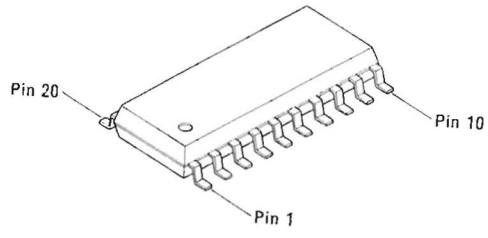

TC74HC244AF
(Q1010, 1016)

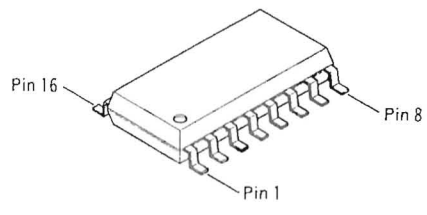

MC74HC4060FL
(Q1018)

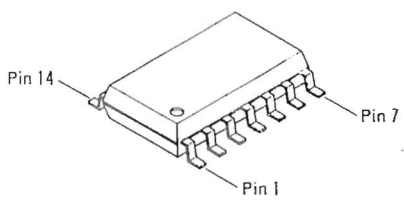

MC74HC00FL
(Q1019)

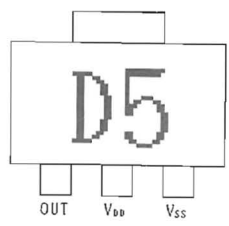

RH5VA45AA (D5)
(Q1017)

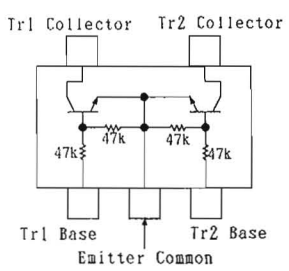

FMG2 (G2)
(Q1005-1007, 1009,
1011-1014,
1020-1022)

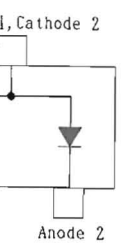

(C3)
1005-1017,

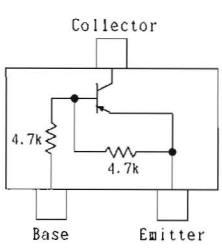

DTA143XK
(Q1024)

REF.	DESCRIPTION	VALUE	WV	TOL.	MFGR'S DESIG	YAESU P/N	VERS.	LOT.
*** CNTL1 UNIT ***								
	PCB with Components					CP5280001		
	Printed Circuit Board					F3543101		
C 1001	CHIP CAP.	100pF	50V	CH	GRM40CH101J50PT	K22170235		
C 1002	CHIP CAP.	100pF	50V	CH	GRM40CH101J50PT	K22170235		
C 1003	CHIP CAP.	100pF	50V	CH	GRM40CH101J50PT	K22170235		
C 1004	CHIP CAP.	100pF	50V	CH	GRM40CH101J50PT	K22170235		
C 1005	CHIP CAP.	100pF	50V	CH	GRM40CH101J50PT	K22170235		
C 1006	CHIP CAP.	100pF	50V	CH	GRM40CH101J50PT	K22170235		
C 1007	CHIP CAP.	100pF	50V	CH	GRM40CH101J50PT	K22170235		
C 1008	CHIP CAP.	100pF	50V	CH	GRM40CH101J50PT	K22170235		
C 1009	CHIP CAP.	100pF	50V	CH	GRM40CH101J50PT	K22170235		
C 1010	CHIP CAP.	100pF	50V	CH	GRM40CH101J50PT	K22170235		
C 1011	CHIP CAP.	100pF	50V	CH	GRM40CH101J50PT	K22170235		
C 1012	CHIP CAP.	100pF	50V	CH	GRM40CH101J50PT	K22170235		
C 1013	CHIP CAP.	100pF	50V	CH	GRM40CH101J50PT	K22170235		
C 1014	AL. ELECTRO. CAP.	10uF	50V		50V100M5X11TR5	K46170021		
C 1015	AL. ELECTRO. CAP.	10uF	50V		50V100M5X11TR5	K46170021		
C 1016	CHIP CAP.	0.01uF	50V	B	GRM40B103M50PT	K22170817		
C 1017	CHIP CAP.	0.001uF	50V	B	GRM40B102M50PT	K22170805		
C 1018	CHIP CAP.	0.001uF	50V	B	GRM40B102M50PT	K22170805		
C 1019	TANTALUM CAP.	22uF	6.3V		DNOJ220M1S	K70087226		
C 1020	AL. ELECTRO. CAP.	100uF	25V		25V101M6X11TR5	K46140005		
C 1021	AL. ELECTRO. CAP.	100uF	25V		25V101M6X11TR5	K46140005		
C 1022	CHIP CAP.	0.01uF	50V	B	GRM40B103M50PT	K22170817		
C 1023	CHIP CAP.	100pF	50V	CH	GRM40CH101J50PT	K22170235		
C 1024	CHIP CAP.	0.01uF	50V	B	GRM40B103M50PT	K22170817		
C 1025	CHIP CAP.	100pF	50V	CH	GRM40CH101J50PT	K22170235		
C 1026	CHIP CAP.	0.01uF	50V	B	GRM40B103M50PT	K22170817		
C 1027	CHIP CAP.	100pF	50V	CH	GRM40CH101J50PT	K22170235		
C 1028	CHIP CAP.	100pF	50V	CH	GRM40CH101J50PT	K22170235		
C 1029	CHIP CAP.	100pF	50V	CH	GRM40CH101J50PT	K22170235		
C 1030	CHIP CAP.	100pF	50V	CH	GRM40CH101J50PT	K22170235		
C 1031	CHIP CAP.	100pF	50V	CH	GRM40CH101J50PT	K22170235		
C 1032	CHIP CAP.	100pF	50V	CH	GRM40CH101J50PT	K22170235		
C 1033	CHIP CAP.	100pF	50V	CH	GRM40CH101J50PT	K22170235		
C 1034	CHIP CAP.	100pF	50V	CH	GRM40CH101J50PT	K22170235		
C 1035	CHIP CAP.	0.01uF	50V	B	GRM40B103M50PT	K22170817		
C 1036	CHIP CAP.	100pF	50V	CH	GRM40CH101J50PT	K22170235		
C 1037	CHIP CAP.	100pF	50V	CH	GRM40CH101J50PT	K22170235		
C 1038	CHIP CAP.	100pF	50V	CH	GRM40CH101J50PT	K22170235		
C 1039	CHIP CAP.	13pF	50V	CH	GRM40CH130J50PT	K22170214		
C 1040	CHIP CAP.	2pF	50V	CK	GRM40CK020C50PT	K22170203		
C 1041	CHIP CAP.	2pF	50V	CK	GRM40CK020C50PT	K22170203		
C 1042	CHIP CAP.	13pF	50V	CH	GRM40CH130J50PT	K22170214		
C 1043	CHIP CAP.	0.01uF	50V	B	GRM40B103M50PT	K22170817		
C 1044	TANTALUM CAP.	22uF	6.3V		DNOJ220M1S	K70087226		
C 1045	CHIP CAP.	0.01uF	50V	B	GRM40B103M50PT	K22170817		
C 1046	CHIP CAP.	100pF	50V	CH	GRM40CH101J50PT	K22170235		

REF.	DESCRIPTION	VALUE	WV	TOL.	MFR'S DESIG	YAESU P/N	VERS.	LOT.
C 1047	CHIP CAP.	100pF	50V	CH	GRM40CH101J50PT	K22170235		
C 1048	CHIP CAP.	100pF	50V	CH	GRM40CH101J50PT	K22170235		
C 1049	CHIP CAP.	100pF	50V	CH	GRM40CH101J50PT	K22170235		
C 1050	CHIP CAP.	100pF	50V	CH	GRM40CH101J50PT	K22170235		
C 1051	CHIP CAP.	0.01uF	50V	B	GRM40B103M50PT	K22170817		
C 1052	CHIP CAP.	0.001uF	50V	B	GRM40B102M50PT	K22170805		
C 1053	CHIP CAP.	0.1uF	25V	B	GRM40B104M25PT	K22140811		
C 1054	CHIP CAP.	0.01uF	50V	B	GRM40B103M50PT	K22170817		
C 1055	CHIP CAP.	0.01uF	50V	B	GRM40B103M50PT	K22170817		
D 1001	LED				TLR211	G2090342		
D 1002	LED				TLR211	G2090342		
D 1003	DIODE				1SS226 TE85R	G2070003		
D 1004	LED				TLR211	G2090342		
D 1005	DIODE				1SS226 TE85R	G2070003		
D 1006	DIODE				1SS226 TE85R	G2070003		
D 1007	DIODE				1SS226 TE85R	G2070003		
D 1008	DIODE				1SS226 TE85R	G2070003		
D 1009	DIODE				1SS226 TE85R	G2070003		
D 1010	DIODE				1SS226 TE85R	G2070003		
D 1011	DIODE				1SS226 TE85R	G2070003		
D 1012	DIODE				1SS226 TE85R	G2070003		
D 1013	DIODE				1SS226 TE85R	G2070003		
D 1014	DIODE				1SS226 TE85R	G2070003		
D 1015	DIODE				1SS226 TE85R	G2070003		
D 1016	DIODE				1SS226 TE85R	G2070003		
D 1017	DIODE				1SS226 TE85R	G2070003		
D 1018	DIODE				DAN202K T146	G2070182		
D 1019	DIODE				1SS226 TE85R	G2070003		
F 1001	FUSE					Q0000002		
FH1001	FUSE (2pcs)				HC1	P2000049		
J 1001	CONNECTOR				SC25-10WL	P0090717		
J 1002	CONNECTOR				SC25-08WL	P0090715		
J 1003	CONNECTOR				9130S-10	P1090794		
J 1004	CONNECTOR				SC25-06WL	P0090639		
J 1005	CONNECTOR				SC25-05WL	P0090638		
J 1006	CONNECTOR				SC25-12WL	P0090719		
J 1007	CONNECTOR				9130S-10	P1090794		
J 1008	CONNECTOR				9130S-10	P1090794		
J 1009	CONNECTOR				SC25-13WL	P0090720		
J 1010	CONNECTOR				SC25-03WL	P0090637		
J 1011	CONNECTOR				SC25-07WL	P0090714		
NF1001	FILTER				DSS706-351D221M25	Q9000642		
NF1002	FILTER				DSS706-351D221M25	Q9000642		
NF1003	FILTER				DSS706-351D221M25	Q9000642		
NF1004	FILTER				DSS706-351D221M25	Q9000642		
NF1005	FILTER				DSS706-351D221M25	Q9000642		
NF1006	FILTER				DSS706-351D221M25	Q9000642		

REF.	DESCRIPTION	VALUE	WV	TOL.	MFGR'S DESIG	YAESU P/N	VERS.	LOT.
Q 1001	IC				HA17805P	G1090936		
Q 1002	IC				BR93LC56A	G1091191		
Q 1003	TRANSISTOR				ZSC2812L6-TA	G3328127F		
Q 1004	TRANSISTOR				ZSC2812L6-TA	G3328127F		
Q 1005	TRANSISTOR				FMG2 T99	G3070015		
Q 1006	TRANSISTOR				FMG2 T99	G3070015		
Q 1007	TRANSISTOR				FMG2 T99	G3070015		
Q 1008	IC				M38063M6-331GP	G1092025		
Q 1009	TRANSISTOR				FMG2 T99	G3070015		
Q 1010	IC				TC74HC244AF(EL)	G1091566		
Q 1011	TRANSISTOR				FMG2 T99	G3070015		
Q 1012	TRANSISTOR				FMG2 T99	G3070015		
Q 1013	TRANSISTOR				FMG2 T99	G3070015		
Q 1014	TRANSISTOR				FMG2 T99	G3070015		
Q 1015	IC				TMS27C256-15JL	G1092023		
Q 1016	IC				TC74HC244AF(EL)	G1091566		
Q 1017	IC				RH5VA45AA-T2	G1090922		
Q 1018	IC				MC74HC4060FL	G1090984		
Q 1019	IC				MC74HC00FL	G1090997		
Q 1020	TRANSISTOR				FMG2 T99	G3070015		
Q 1021	TRANSISTOR				FMG2 T99	G3070015		
Q 1022	TRANSISTOR				FMG2 T99	G3070015		
Q 1023	PHOTO COUPLER				TLP181-GB(TPR)	G0090021		
Q 1024	TRANSISTOR				DTA143XK T97	G3070032		
R 1001	CHIP RES.	22K	1/10W	5%	RMC1/10T 223J	J24205223		
R 1002	CHIP RES.	1K	1/10W	5%	RMC1/10T 102J	J24205102		
R 1003	CHIP RES.	330	1/10W	5%	RMC1/10T 331J	J24205331		
R 1004	CHIP RES.	22K	1/10W	5%	RMC1/10T 223J	J24205223		
R 1005	CHIP RES.	100K	1/10W	5%	RMC1/10T 104J	J24205104		
R 1006	CHIP RES.	330	1/10W	5%	RMC1/10T 331J	J24205331		
R 1007	CHIP RES.	330	1/10W	5%	RMC1/10T 331J	J24205331		
R 1008	CHIP RES.	330	1/10W	5%	RMC1/10T 331J	J24205331		
R 1009	CHIP RES.	330	1/10W	5%	RMC1/10T 331J	J24205331		
R 1010	CHIP RES.	22K	1/10W	5%	RMC1/10T 223J	J24205223		
R 1011	CHIP RES.	22K	1/10W	5%	RMC1/10T 223J	J24205223		
R 1012	CHIP RES.	1.2K	1/10W	5%	RMC1/10T 122J	J24205122		
R 1013	CHIP RES.	22K	1/10W	5%	RMC1/10T 223J	J24205223		
R 1014	CHIP RES.	10K	1/10W	5%	RMC1/10T 103J	J24205103		
R 1015	CHIP RES.	22K	1/10W	5%	RMC1/10T 223J	J24205223		
R 1016	CHIP RES.	22K	1/10W	5%	RMC1/10T 223J	J24205223		
R 1017	CHIP RES.	22K	1/10W	5%	RMC1/10T 223J	J24205223		
R 1018	CHIP RES.	22K	1/10W	5%	RMC1/10T 223J	J24205223		
R 1019	CHIP RES.	1.5K	1/10W	5%	RMC1/10T 152J	J24205152		
R 1020	CHIP RES.	1.2K	1/10W	5%	RMC1/10T 122J	J24205122		
R 1021	CHIP RES.	330	1/10W	5%	RMC1/10T 331J	J24205331		
R 1022	CHIP RES.	22K	1/10W	5%	RMC1/10T 223J	J24205223		
R 1023	CHIP RES.	4.7K	1/10W	5%	RMC1/10T 472J	J24205472		
R 1024	CHIP RES.	1K	1/10W	5%	RMC1/10T 102J	J24205102		
R 1025	CHIP RES.	1K	1/10W	5%	RMC1/10T 102J	J24205102		
R 1026	CHIP RES.	330	1/10W	5%	RMC1/10T 331J	J24205331		

REF.	DESCRIPTION	VALUE	WV	TOL.	MFGR'S DESIG	YAESU P/N	VERS.	LOT.
R 1027	CHIP RES.	2. 2K	1/10W	5%	RMC1/10T 222J	J24205222		
R 1028	CHIP RES.	2. 2K	1/10W	5%	RMC1/10T 222J	J24205222		
R 1029	CHIP RES.	1K	1/10W	5%	RMC1/10T 102J	J24205102		
R 1030	CHIP RES.	3. 3K	1/10W	5%	RMC1/10T 332J	J24205332		
R 1031	CHIP RES.	1K	1/10W	5%	RMC1/10T 102J	J24205102		
R 1032	CHIP RES.	1K	1/10W	5%	RMC1/10T 102J	J24205102		
R 1033	CHIP RES.	1K	1/10W	5%	RMC1/10T 102J	J24205102		
R 1034	CHIP RES.	180	1/10W	5%	RMC1/10T 181J	J24205181		
R 1035	CHIP RES.	47	1/10W	5%	RMC1/10T 470J	J24205470		
R 1036	CHIP RES.	10K	1/10W	5%	RMC1/10T 103J	J24205103		
R 1037	CHIP RES.	22K	1/10W	5%	RMC1/10T 223J	J24205223		
R 1038	CHIP RES.	10K	1/10W	5%	RMC1/10T 103J	J24205103		
R 1039	CHIP RES.	22K	1/10W	5%	RMC1/10T 223J	J24205223		
R 1040	CHIP RES.	22K	1/10W	5%	RMC1/10T 223J	J24205223		
R 1041	CHIP RES.	2. 2K	1/10W	5%	RMC1/10T 222J	J24205222		
R 1042	CHIP RES.	22K	1/10W	5%	RMC1/10T 223J	J24205223		
R 1043	CHIP RES.	1K	1/10W	5%	RMC1/10T 102J	J24205102		
R 1044	CHIP RES.	33K	1/10W	5%	RMC1/10T 333J	J24205333		
R 1045	CHIP RES.	1K	1/10W	5%	RMC1/10T 102J	J24205102		
R 1046	CHIP RES.	33K	1/10W	5%	RMC1/10T 333J	J24205333		
R 1047	CHIP RES.	22K	1/10W	5%	RMC1/10T 223J	J24205223		
R 1048	CHIP RES.	1K	1/10W	5%	RMC1/10T 102J	J24205102		
R 1049	CHIP RES.	33K	1/10W	5%	RMC1/10T 333J	J24205333		
R 1050	CHIP RES.	33K	1/10W	5%	RMC1/10T 333J	J24205333		
R 1051	CHIP RES.	22K	1/10W	5%	RMC1/10T 223J	J24205223		
R 1052	CHIP RES.	33K	1/10W	5%	RMC1/10T 333J	J24205333		
R 1053	CHIP RES.	33K	1/10W	5%	RMC1/10T 333J	J24205333		
R 1054	CHIP RES.	22K	1/10W	5%	RMC1/10T 223J	J24205223		
R 1055	CHIP RES.	22K	1/10W	5%	RMC1/10T 223J	J24205223		
R 1056	CHIP RES.	22K	1/10W	5%	RMC1/10T 223J	J24205223		
R 1057	CHIP RES.	22K	1/10W	5%	RMC1/10T 223J	J24205223		
R 1058	CHIP RES.	22K	1/10W	5%	RMC1/10T 223J	J24205223		
R 1059	CHIP RES.	22K	1/10W	5%	RMC1/10T 223J	J24205223		
R 1060	CHIP RES.	22K	1/10W	5%	RMC1/10T 223J	J24205223		
R 1061	CHIP RES.	100K	1/10W	5%	RMC1/10T 104J	J24205104		
R 1062	CHIP RES.	100K	1/10W	5%	RMC1/10T 104J	J24205104		
R 1063	CHIP RES.	33K	1/10W	5%	RMC1/10T 333J	J24205333		
R 1064	CHIP RES.	4. 7K	1/10W	5%	RMC1/10T 472J	J24205472		
R 1065	CHIP RES.	10K	1/10W	5%	RMC1/10T 103J	J24205103		
R 1066	CHIP RES.	22K	1/10W	5%	RMC1/10T 223J	J24205223		
R 1067	CHIP RES.	22K	1/10W	5%	RMC1/10T 223J	J24205223		
R 1068	CHIP RES.	22K	1/10W	5%	RMC1/10T 223J	J24205223		
R 1069	CHIP RES.	330	1/10W	5%	RMC1/10T 331J	J24205331		
R 1070	CHIP RES.	10K	1/10W	5%	RMC1/10T 103J	J24205103		
R 1071	CHIP RES.	10K	1/10W	5%	RMC1/10T 103J	J24205103		
R 1072	CHIP RES.	330	1/10W	5%	RMC1/10T 331J	J24205331		
R 1073	CHIP RES.	47K	1/10W	5%	RMC1/10T 473J	J24205473		
R 1074	CHIP RES.	33K	1/10W	5%	RMC1/10T 333J	J24205333		
R 1075	CHIP RES.	22K	1/10W	5%	RMC1/10T 223J	J24205223		
R 1076	CHIP RES.	22K	1/10W	5%	RMC1/10T 223J	J24205223		
R 1077	CHIP RES.	22K	1/10W	5%	RMC1/10T 223J	J24205223		
R 1078	CHIP RES.	22K	1/10W	5%	RMC1/10T 223J	J24205223		

REF.	DESCRIPTION	VALUE	WV	TOL.	MFGR'S DESIG	YAESU P/N	VERS.	LOT.
R 1079	CHIP RES.	47K	1/10W	5%	RMC1/10T 473J	J24205473		
R 1080	CHIP RES.	22K	1/10W	5%	RMC1/10T 223J	J24205223		
R 1081	CHIP RES.	0	1/10W	5%	RMC1/10T 000J	J24205000		
R 1082	CHIP RES.	33K	1/10W	5%	RMC1/10T 333J	J24205333		
R 1083	CHIP RES.	2.2K	1/10W	5%	RMC1/10T 222J	J24205222		
R 1084	CHIP RES.	68K	1/10W	5%	RMC1/10T 683J	J24205683		
R 1085	CHIP RES.	2.2K	1/10W	5%	RMC1/10T 222J	J24205222		
R 1086	CHIP RES.	33K	1/10W	5%	RMC1/10T 333J	J24205333		
R 1087	CHIP RES.	22K	1/10W	5%	RMC1/10T 223J	J24205223		
R 1088	CHIP RES.	470	1/10W	5%	RMC1/10T 471J	J24205471		
R 1089	CHIP RES.	2.2K	1/10W	5%	RMC1/10T 222J	J24205222		
R 1090	CHIP RES.	820	1/10W	5%	RMC1/10T 821J	J24205821		
R 1091	CHIP RES.	330	1/10W	5%	RMC1/10T 331J	J24205331		
S 1001	SLIDE SWITCH				SSSS22	N6090057		
S 1002	PUSH SWITCH				SPPJ3-EN1-PLB	N4090130		
X 1001	XTAL	4.9152MHz				H0103064		
Z 1001	LED HOLDER				H-2RV-4	S6000323		
Z 1002	LED HOLDER				H-2RV-4	S6000323		
Z 1003	LED HOLDER				H-2RV-4	S6000323		
	FITTING R					R0136960		
	FITTING L					R0136970		
	FIBER					R7107410		

Parts Layout

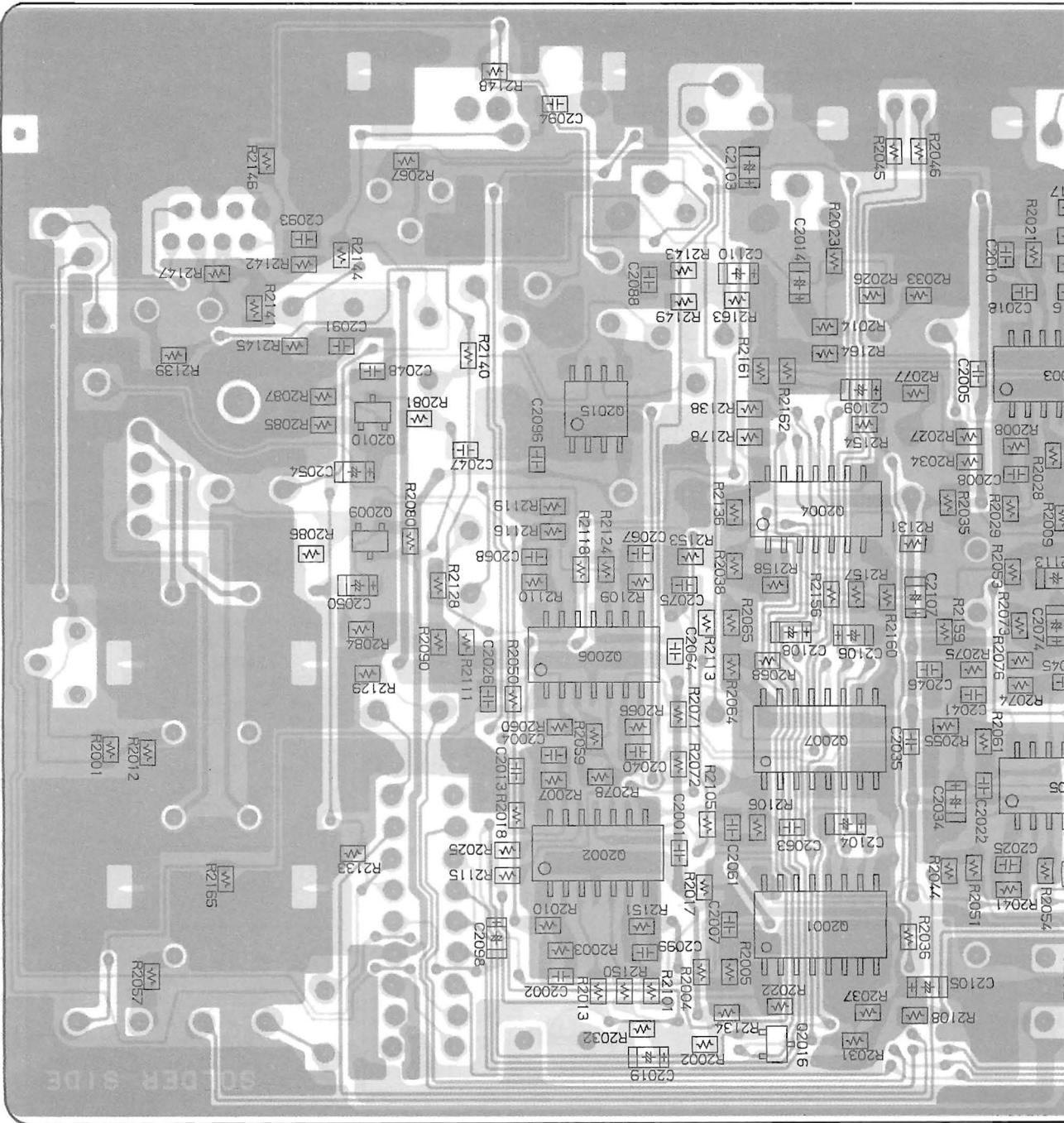

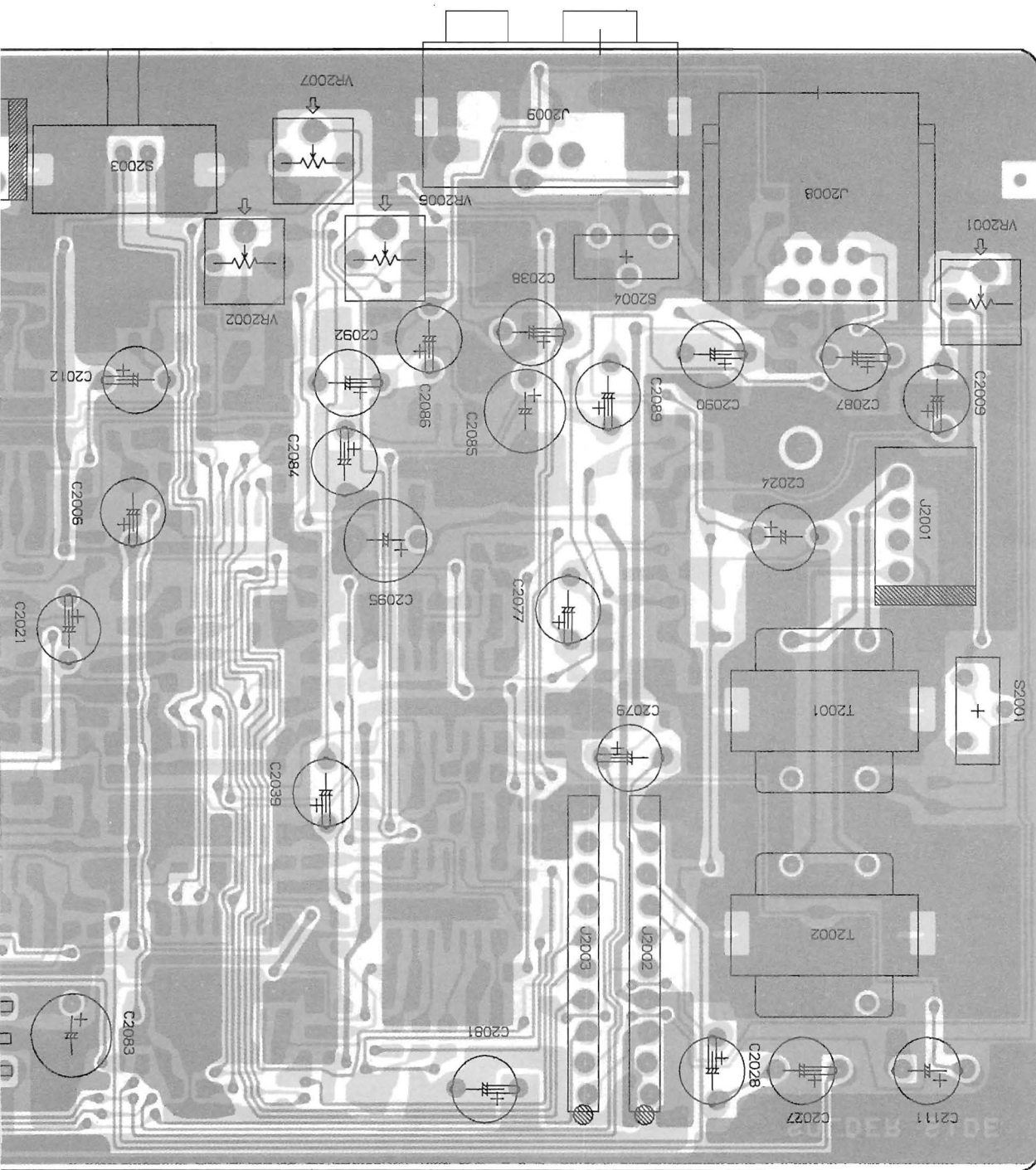

obverse view of component side

Parts Layout

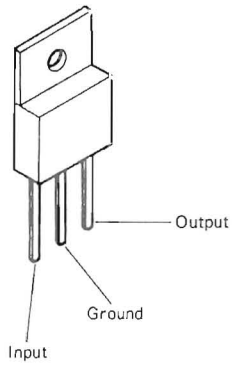

AN6541
(Q2014)

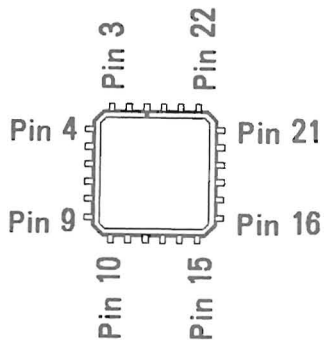

MX165CLH
(Q2008, 2013)

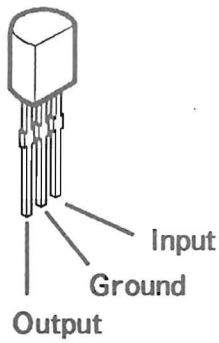

μ PC78L05
(Q2012)

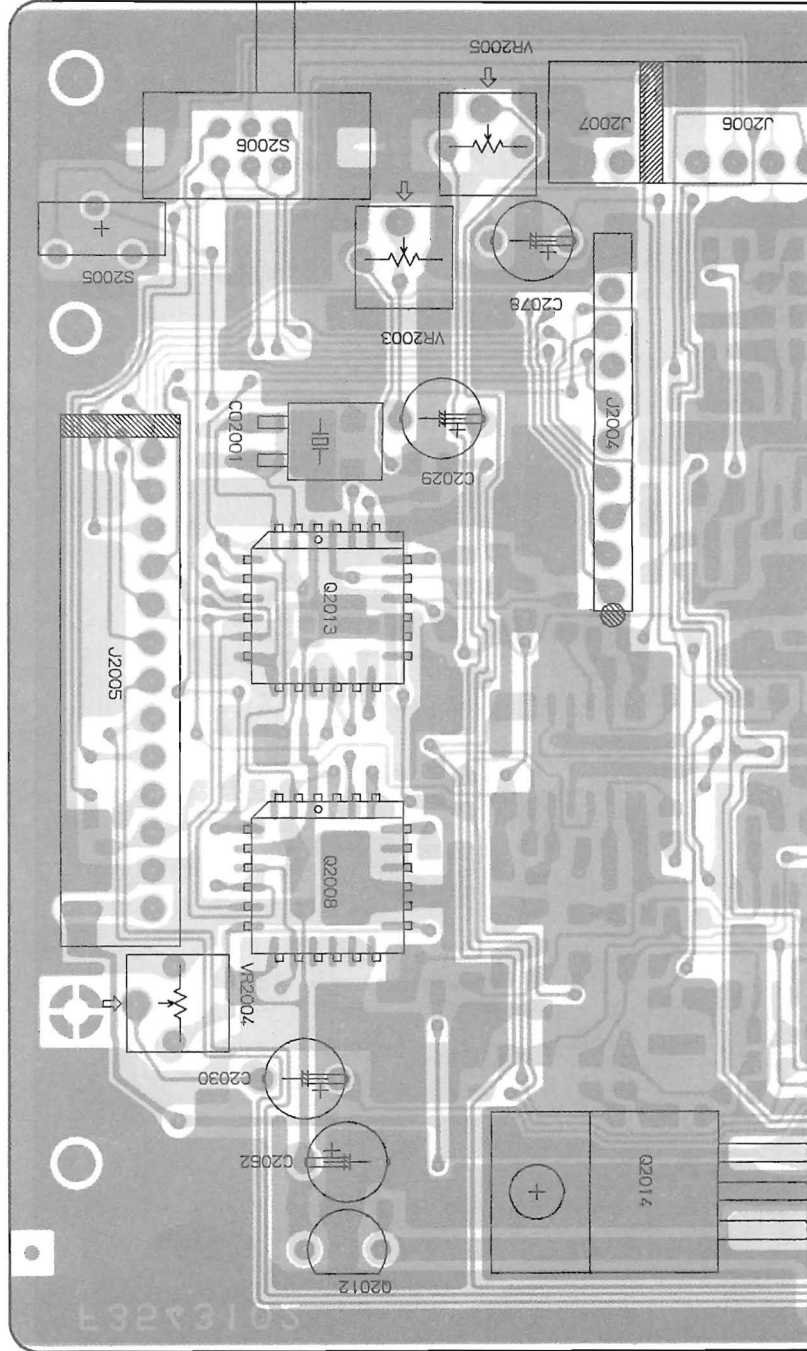

REF.	DESCRIPTION	VALUE	WV	TOL.	MFR'S DESIG	YAESU P/N	VERS.	LOT.
*** CNTL2 UNIT ***								
	PCB with Components					CP5281001	SEP 25	
	PCB with Components					CP5281002	SEP 20	
	PCB with Components					CP5281003	SEP 12.5	
	Printed Circuit Board					F3543102		
C 2001	CHIP CAP.	0.01uF	50V	B	GRM40B103M50PT	K22170817		
C 2002	CHIP CAP.	150pF	50V	CH	GRM40CH151J50PT	K22170239		
C 2003	CHIP CAP.	150pF	50V	CH	GRM40CH151J50PT	K22170239		
C 2004	CHIP CAP.	82pF	50V	CH	GRM40CH820J50PT	K22170233		
C 2005	CHIP CAP.	0.01uF	50V	B	GRM40B103M50PT	K22170817		
C 2006	AL. ELECTRO. CAP.	10uF	50V		50V100M5X11TR5	K46170021		
C 2007	CHIP CAP.	0.01uF	50V	B	GRM40B103M50PT	K22170817		
C 2008	CHIP CAP.	47pF	50V	CH	GRM40CH470J50PT	K22170227		
C 2009	AL. ELECTRO. CAP.	10uF	50V		50V100M5X11TR5	K46170021		
C 2010	CHIP CAP.	470pF	50V	CH	GRM40CH471J50PT	K22170251	SEP 12.5	
C 2010	CHIP CAP.	470pF	50V	CH	GRM40CH471J50PT	K22170251	SEP 20	
C 2010	CHIP CAP.	330pF	50V	CH	GRM40CH331J50PT	K22170247	SEP 25	
C 2011	CHIP CAP.	820pF	50V	W5R	CM21W5R821K50AT	K22170829	SEP 12.5	
C 2011	CHIP CAP.	820pF	50V	W5R	CM21W5R821K50AT	K22170829	SEP 20	
C 2011	CHIP CAP.	0.001uF	50V	B	GRM40B102K50PT	K22170825	SEP 25	
C 2012	AL. ELECTRO. CAP.	10uF	50V		50V100M5X11TR5	K46170021		
C 2013	CHIP CAP.	0.001uF	50V	B	GRM40B102K50PT	K22170825		
C 2014	TANTALUM CHIP CAP.	4.7uF	16V		TEMSVA1C475M-8R	K78120031		
C 2015	TANTALUM CHIP CAP.	4.7uF	16V		TEMSVA1C475M-8R	K78120031		
C 2016	CHIP CAP.	68pF	50V	CH	GRM40CH680J50PT	K22170231	SEP 12.5	
C 2016	CHIP CAP.	68pF	50V	CH	GRM40CH680J50PT	K22170231	SEP 20	
C 2016	CHIP CAP.	100pF	50V	CH	GRM40CH101J50PT	K22170235	SEP 25	
C 2017	CHIP CAP.	330pF	50V	CH	GRM40CH331J50PT	K22170247	SEP 12.5	
C 2017	CHIP CAP.	330pF	50V	CH	GRM40CH331J50PT	K22170247	SEP 20	
C 2017	CHIP CAP.	180pF	50V	CH	GRM40CH181J50PT	K22170241	SEP 25	
C 2018	CHIP CAP.	100pF	50V	CH	GRM40CH101J50PT	K22170235	SEP 12.5	
C 2018	CHIP CAP.	100pF	50V	CH	GRM40CH101J50PT	K22170235	SEP 20	
C 2018	CHIP CAP.	220pF	50V	CH	GRM40CH221J50PT	K22170243	SEP 25	
C 2019	TANTALUM CHIP CAP.	1uF	16V		TESVA1C105M1-8R	K78120009		
C 2020	TANTALUM CHIP CAP.	1uF	16V		TESVA1C105M1-8R	K78120009		
C 2021	AL. ELECTRO. CAP.	10uF	50V		50V100M5X11TR5	K46170021		
C 2022	CHIP CAP.	0.01uF	50V	B	GRM40B103M50PT	K22170817		
C 2023	CHIP CAP.	0.01uF	50V	B	GRM40B103M50PT	K22170817		
C 2024	AL. ELECTRO. CAP.	10uF	50V		50V100M5X11TR5	K46170021		
C 2025	CHIP CAP.	0.0022uF	50V	B	GRM40B222M50PT	K22170809		
C 2026	CHIP CAP.	330pF	50V	CH	GRM40CH331J50PT	K22170247		
C 2027	AL. ELECTRO. CAP.	10uF	50V		50V100M5X11TR5	K46170021		
C 2028	AL. ELECTRO. CAP.	10uF	50V		50V100M5X11TR5	K46170021		
C 2029	AL. ELECTRO. CAP.	10uF	50V		50V100M5X11TR5	K46170021		
C 2030	AL. ELECTRO. CAP.	10uF	50V		50V100M5X11TR5	K46170021		
C 2031	CHIP CAP.	0.01uF	50V	B	GRM40B103M50PT	K22170817		
C 2032	CHIP CAP.	0.01uF	50V	B	GRM40B103M50PT	K22170817		
C 2033	CHIP CAP.	68pF	50V	CH	GRM40CH680J50PT	K22170231		
C 2034	TANTALUM CHIP CAP.	1uF	16V		TESVA1C105M1-8R	K78120009		

REF.	DESCRIPTION	VALUE	WV	TOL.	MFGR'S DESIG	YAESU P/N	VERS.	LOT.
C 2035	CHIP CAP.	0.01uF	50V	B	GRM40B103M50PT	K22170817		
C 2036	TANTALUM CHIP CAP.	0.47uF	25V		TESVA1E474M1-8R	K78140009		
C 2037	TANTALUM CHIP CAP.	4.7uF	16V		TEMSVA1C475M-8R	K78120031		
C 2038	AL. ELECTRO. CAP.	10uF	50V		50V100M5X11TR5	K46170021		
C 2039	AL. ELECTRO. CAP.	10uF	50V		50V100M5X11TR5	K46170021		
C 2040	CHIP CAP.	0.0022uF	50V	B	GRM40B222M50PT	K22170809		
C 2041	CHIP CAP.	0.0015uF	50V	B	GRM40B152M50PT	K22170807		
C 2042	CHIP CAP.	0.1uF	25V	B	GRM40B104M25PT	K22140811		
C 2043	CHIP CAP.	0.1uF	25V	B	GRM40B104M25PT	K22140811		
C 2044	CHIP CAP.	0.1uF	25V	B	GRM40B104M25PT	K22140811		
C 2045	CHIP CAP.	100pF	50V	CH	GRM40CH101J50PT	K22170235		
C 2046	CHIP CAP.	0.001uF	50V	B	GRM40B102K50PT	K22170825		
C 2047	CHIP CAP.	0.01uF	50V	B	GRM40B103M50PT	K22170817		
C 2048	CHIP CAP.	0.0047uF	50V	B	GRM40B472M50PT	K22170813		
C 2049	CHIP CAP.	330pF	50V	CH	GRM40CH331J50PT	K22170247		
C 2050	TANTALUM CHIP CAP.	4.7uF	16V		ECST1CY475R	K78120039		
C 2051	TANTALUM CHIP CAP.	0.47uF	35V		TEMSVA1V474M-8R	K78160029		
C 2052	TANTALUM CHIP CAP.	4.7uF	16V		ECST1CY475R	K78120039		
C 2053	CHIP CAP.	0.1uF	25V	B	GRM40B104M25PT	K22140811		
C 2054	TANTALUM CHIP CAP.	4.7uF	16V		ECST1CY475R	K78120039		
C 2055	TANTALUM CHIP CAP.	4.7uF	16V		ECST1CY475R	K78120039		
C 2056	CHIP CAP.	0.1uF	25V	B	GRM40B104M25PT	K22140811		
C 2057	CHIP CAP.	0.01uF	50V	B	GRM40B103M50PT	K22170817		
C 2058	CHIP CAP.	0.1uF	25V	B	GRM40B104M25PT	K22140811		
C 2059	CHIP CAP.	0.01uF	50V	B	GRM40B103M50PT	K22170817		
C 2060	CHIP CAP.	0.01uF	50V	B	GRM40B103M50PT	K22170817		
C 2061	CHIP CAP.	330pF	50V	CH	GRM40CH331J50PT	K22170247		
C 2062	AL. ELECTRO. CAP.	10uF	50V		50V100M5X11TR5	K46170021		
C 2063	CHIP CAP.	0.1uF	25V	B	GRM40B104M25PT	K22140811		
C 2064	CHIP CAP.	0.01uF	50V	B	GRM40B103M50PT	K22170817		
C 2065	CHIP CAP.	0.01uF	50V	B	GRM40B103M50PT	K22170817		
C 2066	CHIP CAP.	0.01uF	50V	B	GRM40B103M50PT	K22170817		
C 2067	CHIP CAP.	330pF	50V	CH	GRM40CH331J50PT	K22170247		
C 2068	CHIP CAP.	270pF	50V	CH	GRM40CH271J50PT	K22170245		
C 2069	CHIP CAP.	0.01uF	50V	B	GRM40B103M50PT	K22170817		
C 2070	TANTALUM CHIP CAP.	1uF	16V		TESVA1C105M1-8R	K78120009		
C 2071	CHIP CAP.	330pF	50V	CH	GRM40CH331J50PT	K22170247		
C 2072	CHIP CAP.	220pF	50V	CH	GRM40CH221J50PT	K22170243		
C 2073	CHIP CAP.	220pF	50V	CH	GRM40CH221J50PT	K22170243		
C 2074	TANTALUM CHIP CAP.	1uF	16V		TESVA1C105M1-8R	K78120009		
C 2075	CHIP CAP.	0.1uF	25V	B	GRM40B104M25PT	K22140811		
C 2077	AL. ELECTRO. CAP.	10uF	50V		50V100M5X11TR5	K46170021		
C 2078	AL. ELECTRO. CAP.	10uF	50V		50V100M5X11TR5	K46170021		
C 2079	AL. ELECTRO. CAP.	10uF	50V		50V100M5X11TR5	K46170021		
C 2080	CHIP CAP.	0.01uF	50V	B	GRM40B103M50PT	K22170817		
C 2081	AL. ELECTRO. CAP.	100uF	10V		10V101M5X11TR5	K46100004		
C 2082	CHIP CAP.	0.01uF	50V	B	GRM40B103M50PT	K22170817		
C 2083	AL. ELECTRO. CAP.	100uF	25V		25V101M6X11TR5	K46140005		
C 2084	AL. ELECTRO. CAP.	22uF	50V		50V220M5X11TR5	K46170022		
C 2085	AL. ELECTRO. CAP.	100uF	25V		25V101M6X11TR5	K46140005		
C 2086	AL. ELECTRO. CAP.	10uF	50V		50V100M5X11TR5	K46170021		
C 2087	AL. ELECTRO. CAP.	10uF	50V		50V100M5X11TR5	K46170021		

REF.	DESCRIPTION	VALUE	WV	TOL.	MFGR'S DESIG	YAESU P/N	VERS.	LOT.
C 2088	CHIP CAP.	0.1uF	25V	B	GRM40B104M25PT	K22140811		
C 2089	AL. ELECTRO. CAP.	10uF	50V		50V100M5X11TR5	K46170021		
C 2090	AL. ELECTRO. CAP.	47uF	25V		25V470M5X11TR5	K46140004		
C 2091	CHIP CAP.	0.01uF	50V	B	GRM40B103M50PT	K22170817		
C 2092	AL. ELECTRO. CAP.	10uF	50V		50V100M5X11TR5	K46170021		
C 2093	CHIP CAP.	100pF	50V	CH	GRM40CH101J50PT	K22170235		
C 2094	CHIP CAP.	100pF	50V	CH	GRM40CH101J50PT	K22170235		
C 2095	AL. ELECTRO. CAP.	100uF	25V		25V101M6X11TR5	K46140005		
C 2096	CHIP CAP.	0.1uF	25V	B	GRM40B104M25PT	K22140811		
C 2097	TANTALUM CHIP CAP.	1uF	16V		TESVA1C105M1-8R	K78120009		
C 2098	TANTALUM CHIP CAP.	1uF	16V		TESVA1C105M1-8R	K78120009		
C 2099	CHIP CAP.	330pF	50V	CH	GRM40CH331J50PT	K22170247		
C 2100	TANTALUM CHIP CAP.	4.7uF	16V		TEMSVA1C475M-8R	K78120031		
C 2101	TANTALUM CHIP CAP.	4.7uF	16V		TEMSVA1C475M-8R	K78120031		
C 2102	TANTALUM CHIP CAP.	4.7uF	16V		TEMSVA1C475M-8R	K78120031		
C 2103	TANTALUM CHIP CAP.	4.7uF	16V		ECST1CY475R	K78120039		
C 2104	TANTALUM CHIP CAP.	4.7uF	16V		ECST1CY475R	K78120039		
C 2105	TANTALUM CHIP CAP.	4.7uF	16V		ECST1CY475R	K78120039		
C 2106	TANTALUM CHIP CAP.	4.7uF	16V		ECST1CY475R	K78120039		
C 2107	TANTALUM CHIP CAP.	4.7uF	16V		ECST1CY475R	K78120039		
C 2108	TANTALUM CHIP CAP.	4.7uF	16V		ECST1CY475R	K78120039		
C 2109	TANTALUM CHIP CAP.	4.7uF	16V		ECST1CY475R	K78120039		
C 2110	TANTALUM CHIP CAP.	4.7uF	16V		ECST1CY475R	K78120039		
C 2111	AL. ELECTRO. CAP.	10uF	50V		50V100M5X11TR5	K46170021		
C 2112	TANTALUM CHIP CAP.	1uF	16V		TESVA1C105M1-8R	K78120009		
C 2113	TANTALUM CHIP CAP.	4.7uF	16V		ECST1CY475R	K78120039		
C 2114	CHIP CAP.	100pF	50V	CH	GRM40CH101J50PT	K22170235		
C02001	CERAMIC OSC				CSB1000J221T	H7900550		
D 2003	DIODE				1SS184 TE85R	G2070009		
J 2001	CONNECTOR				SC25-04WL	P0090713		
J 2002	CONNECTOR				6027B-10Z103-T	P0090956		
J 2003	CONNECTOR				6027B-10Z103-T	P0090956		
J 2004	CONNECTOR				6027B-10Z103-T	P0090956		
J 2005	CONNECTOR				SC25-13WL	P0090720		
J 2006	CONNECTOR				SC25-04WL	P0090713		
J 2007	CONNECTOR				SC25-02WL	P0090712		
J 2008	CONNECTOR				R41-2736H	P1090677		
J 2009	CONNECTOR				HSJ1468-01-120	P1090691		
Q 2001	IC				MC14053BFR1	G1091524		
Q 2002	IC				NJM2902M-T2	G1090908		
Q 2003	IC				NJM2902M-T2	G1090908		
Q 2004	IC				NJU4066BM(T2)	G1091433		
Q 2005	IC				NJM2902M-T2	G1090908		
Q 2006	IC				NJM2902M-T2	G1090908		
Q 2007	IC				MC14053BFR1	G1091524		
Q 2008	IC				MX165CLH-TR	G1092010		
Q 2009	TRANSISTOR				2SC2812L6-TA	G3328127F		
Q 2010	TRANSISTOR				2SC2812L6-TA	G3328127F		

REF.	DESCRIPTION	VALUE	WV	TOL.	MFGR'S DESIG	YAESU P/N	VERS.	LOT.
Q 2011	IC				NJM2902M-T2	G1090908		
Q 2012	IC				UPC78L05J	G1090848		
Q 2013	IC				MX165CLH-TR	G1092010		
Q 2014	IC				AN6541	G1091146		
Q 2015	IC				TDA7233D-TR	G1091112		
Q 2016	TRANSISTOR				DTC144EK T147	G3070033		
R 2001	CHIP RES.	18K	1/10W	5%	RMC1/10T 183J	J24205183		
R 2002	CHIP RES.	6.8K	1/10W	5%	RMC1/10T 682J	J24205682		
R 2003	CHIP RES.	56K	1/10W	5%	RMC1/10T 563J	J24205563		
R 2004	CHIP RES.	47K	1/10W	5%	RMC1/10T 473J	J24205473		
R 2005	CHIP RES.	47K	1/10W	5%	RMC1/10T 473J	J24205473		
R 2006	CHIP RES.	68K	1/10W	5%	RMC1/10T 683J	J24205683		
R 2007	CHIP RES.	220K	1/10W	5%	RMC1/10T 224J	J24205224		
R 2008	CHIP RES.	68K	1/10W	5%	RMC1/10T 683J	J24205683		
R 2009	CHIP RES.	1.5K	1/10W	5%	RMC1/10T 152J	J24205152		
R 2010	CHIP RES.	4.7K	1/10W	5%	RMC1/10T 472J	J24205472		
R 2011	CHIP RES.	560	1/10W	5%	RMC1/10T 561J	J24205561		
R 2012	CHIP RES.	560	1/10W	5%	RMC1/10T 561J	J24205561		
R 2013	CHIP RES.	47K	1/10W	5%	RMC1/10T 473J	J24205473		
R 2014	CHIP RES.	33K	1/10W	5%	RMC1/10T 333J	J24205333		
R 2015	CHIP RES.	220K	1/10W	5%	RMC1/10T 224J	J24205224	SEP 12.5	
R 2015	CHIP RES.	180K	1/10W	5%	RMC1/10T 184J	J24205184	SEP 20	
R 2015	CHIP RES.	150K	1/10W	5%	RMC1/10T 154J	J24205154	SEP 25	
R 2016	CHIP RES.	220K	1/10W	5%	RMC1/10T 224J	J24205224	SEP 12.5	
R 2016	CHIP RES.	180K	1/10W	5%	RMC1/10T 184J	J24205184	SEP 20	
R 2016	CHIP RES.	150K	1/10W	5%	RMC1/10T 154J	J24205154	SEP 25	
R 2017	CHIP RES.	560K	1/10W	5%	RMC1/10T 564J	J24205564		
R 2018	CHIP RES.	15K	1/10W	5%	RMC1/10T 153J	J24205153		
R 2019	CHIP RES.	220K	1/10W	5%	RMC1/10T 224J	J24205224	SEP 12.5	
R 2019	CHIP RES.	180K	1/10W	5%	RMC1/10T 184J	J24205184	SEP 20	
R 2019	CHIP RES.	150K	1/10W	5%	RMC1/10T 154J	J24205154	SEP 25	
R 2020	CHIP RES.	220K	1/10W	5%	RMC1/10T 224J	J24205224	SEP 12.5	
R 2020	CHIP RES.	180K	1/10W	5%	RMC1/10T 184J	J24205184	SEP 20	
R 2020	CHIP RES.	150K	1/10W	5%	RMC1/10T 154J	J24205154	SEP 25	
R 2021	CHIP RES.	220K	1/10W	5%	RMC1/10T 224J	J24205224	SEP 12.5	
R 2021	CHIP RES.	180K	1/10W	5%	RMC1/10T 184J	J24205184	SEP 20	
R 2021	CHIP RES.	150K	1/10W	5%	RMC1/10T 154J	J24205154	SEP 25	
R 2022	CHIP RES.	4.7K	1/10W	5%	RMC1/10T 472J	J24205472		
R 2023	CHIP RES.	33K	1/10W	5%	RMC1/10T 333J	J24205333		
R 2024	CHIP RES.	33K	1/10W	5%	RMC1/10T 333J	J24205333		
R 2025	CHIP RES.	47K	1/10W	5%	RMC1/10T 473J	J24205473		
R 2026	CHIP RES.	2.2K	1/10W	5%	RMC1/10T 222J	J24205222		
R 2027	CHIP RES.	4.7K	1/10W	5%	RMC1/10T 472J	J24205472		
R 2028	CHIP RES.	47K	1/10W	5%	RMC1/10T 473J	J24205473		
R 2029	CHIP RES.	4.7K	1/10W	5%	RMC1/10T 472J	J24205472		
R 2030	CHIP RES.	47K	1/10W	5%	RMC1/10T 473J	J24205473		
R 2031	CHIP RES.	47K	1/10W	5%	RMC1/10T 473J	J24205473		
R 2032	CHIP RES.	6.8K	1/10W	5%	RMC1/10T 682J	J24205682		
R 2033	CHIP RES.	4.7K	1/10W	5%	RMC1/10T 472J	J24205472		
R 2034	CHIP RES.	4.7K	1/10W	5%	RMC1/10T 472J	J24205472		
R 2035	CHIP RES.	15K	1/10W	5%	RMC1/10T 153J	J24205153		

REF.	DESCRIPTION	VALUE	WV	TOL.	MFGR'S DESIG	YAESU P/N	VERS.	LOT.
R 2036	CHIP RES.	4.7K	1/10W	5%	RMC1/10T 472J	J24205472		
R 2037	CHIP RES.	1.2K	1/10W	5%	RMC1/10T 122J	J24205122		
R 2038	CHIP RES.	10K	1/10W	5%	RMC1/10T 103J	J24205103		
R 2039	CHIP RES.	1.2K	1/10W	5%	RMC1/10T 122J	J24205122		
R 2040	CHIP RES.	47K	1/10W	5%	RMC1/10T 473J	J24205473		
R 2041	CHIP RES.	6.8K	1/10W	5%	RMC1/10T 682J	J24205682		
R 2043	CHIP RES.	5.6K	1/10W	5%	RMC1/10T 562J	J24205562		
R 2044	CHIP RES.	6.8K	1/10W	5%	RMC1/10T 682J	J24205682		
R 2045	CHIP RES.	100K	1/10W	5%	RMC1/10T 104J	J24205104		
R 2046	CHIP RES.	100K	1/10W	5%	RMC1/10T 104J	J24205104		
R 2047	CHIP RES.	22K	1/10W	5%	RMC1/10T 223J	J24205223		
R 2048	CHIP RES.	82K	1/10W	5%	RMC1/10T 823J	J24205823		
R 2049	CHIP RES.	82K	1/10W	5%	RMC1/10T 823J	J24205823		
R 2050	CHIP RES.	47K	1/10W	5%	RMC1/10T 473J	J24205473		
R 2051	CHIP RES.	3.3K	1/10W	5%	RMC1/10T 332J	J24205332		
R 2053	CHIP RES.	1K	1/10W	5%	RMC1/10T 102J	J24205102		
R 2054	CHIP RES.	47K	1/10W	5%	RMC1/10T 473J	J24205473		
R 2055	CHIP RES.	4.7K	1/10W	5%	RMC1/10T 472J	J24205472		
R 2056	CHIP RES.	47K	1/10W	5%	RMC1/10T 473J	J24205473		
R 2057	CHIP RES.	560	1/10W	5%	RMC1/10T 561J	J24205561		
R 2058	CHIP RES.	220K	1/10W	5%	RMC1/10T 224J	J24205224		
R 2059	CHIP RES.	47K	1/10W	5%	RMC1/10T 473J	J24205473		
R 2060	CHIP RES.	5.6K	1/10W	5%	RMC1/10T 562J	J24205562		
R 2061	CHIP RES.	4.7K	1/10W	5%	RMC1/10T 472J	J24205472		
R 2062	CHIP RES.	0	1/10W	5%	RMC1/10T 000J	J24205000		
R 2063	CHIP RES.	47K	1/10W	5%	RMC1/10T 473J	J24205473		
R 2064	CHIP RES.	47K	1/10W	5%	RMC1/10T 473J	J24205473		
R 2065	CHIP RES.	47K	1/10W	5%	RMC1/10T 473J	J24205473		
R 2066	CHIP RES.	560K	1/10W	5%	RMC1/10T 564J	J24205564		
R 2067	CHIP RES.	18K	1/10W	5%	RMC1/10T 183J	J24205183		
R 2068	CHIP RES.	560K	1/10W	5%	RMC1/10T 564J	J24205564		
R 2069	CHIP RES.	47K	1/10W	5%	RMC1/10T 473J	J24205473		
R 2071	CHIP RES.	68K	1/10W	5%	RMC1/10T 683J	J24205683		
R 2072	CHIP RES.	82K	1/10W	5%	RMC1/10T 823J	J24205823		
R 2073	CHIP RES.	100K	1/10W	5%	RMC1/10T 104J	J24205104		
R 2074	CHIP RES.	39K	1/10W	5%	RMC1/10T 393J	J24205393		
R 2075	CHIP RES.	270K	1/10W	5%	RMC1/10T 274J	J24205274		
R 2076	CHIP RES.	39K	1/10W	5%	RMC1/10T 393J	J24205393		
R 2077	CHIP RES.	4.7K	1/10W	5%	RMC1/10T 472J	J24205472		
R 2078	CHIP RES.	47K	1/10W	5%	RMC1/10T 473J	J24205473		
R 2079	CHIP RES.	47K	1/10W	5%	RMC1/10T 473J	J24205473		
R 2080	CHIP RES.	10K	1/10W	5%	RMC1/10T 103J	J24205103		
R 2081	CHIP RES.	10K	1/10W	5%	RMC1/10T 103J	J24205103		
R 2082	CHIP RES.	47K	1/10W	5%	RMC1/10T 473J	J24205473		
R 2083	CHIP RES.	330K	1/10W	5%	RMC1/10T 334J	J24205334		
R 2084	CHIP RES.	10K	1/10W	5%	RMC1/10T 103J	J24205103		
R 2085	CHIP RES.	10K	1/10W	5%	RMC1/10T 103J	J24205103		
R 2086	CHIP RES.	1K	1/10W	5%	RMC1/10T 102J	J24205102		
R 2087	CHIP RES.	1K	1/10W	5%	RMC1/10T 102J	J24205102		
R 2088	CHIP RES.	47K	1/10W	5%	RMC1/10T 473J	J24205473		
R 2089	CHIP RES.	47K	1/10W	5%	RMC1/10T 473J	J24205473		
R 2090	CHIP RES.	100	1/10W	5%	RMC1/10T 101J	J24205101		

REF.	DESCRIPTION	VALUE	WV	TOL.	MFGR'S DESIG	YAESU P/N	VERS.	LOT.
R 2091	CHIP RES.	4.7K	1/10W	5%	RMC1/10T 472J	J24205472		
R 2093	CHIP RES.	2.2M	1/10W	5%	RMC1/10T 225J	J24205225		
R 2094	CHIP RES.	47K	1/10W	5%	RMC1/10T 473J	J24205473		
R 2096	CHIP RES.	4.7K	1/10W	5%	RMC1/10T 472J	J24205472		
R 2097	CHIP RES.	22K	1/10W	5%	RMC1/10T 223J	J24205223		
R 2098	CHIP RES.	82K	1/10W	5%	RMC1/10T 823J	J24205823		
R 2099	CHIP RES.	4.7K	1/10W	5%	RMC1/10T 472J	J24205472		
R 2100	CHIP RES.	82K	1/10W	5%	RMC1/10T 823J	J24205823		
R 2101	CHIP RES.	47K	1/10W	5%	RMC1/10T 473J	J24205473		
R 2102	CHIP RES.	6.8K	1/10W	5%	RMC1/10T 682J	J24205682		
R 2103	CHIP RES.	6.8K	1/10W	5%	RMC1/10T 682J	J24205682		
R 2104	CHIP RES.	1M	1/10W	5%	RMC1/10T 105J	J24205105		
R 2105	CHIP RES.	10K	1/10W	5%	RMC1/10T 103J	J24205103		
R 2106	CHIP RES.	47K	1/10W	5%	RMC1/10T 473J	J24205473		
R 2107	CHIP RES.	2.2K	1/10W	5%	RMC1/10T 222J	J24205222		
R 2108	CHIP RES.	0	1/10W	5%	RMC1/10T 000J	J24205000		
R 2109	CHIP RES.	56K	1/10W	5%	RMC1/10T 563J	J24205563		
R 2110	CHIP RES.	100K	1/10W	5%	RMC1/10T 104J	J24205104		
R 2111	CHIP RES.	6.8K	1/10W	5%	RMC1/10T 682J	J24205682		
R 2112	CHIP RES.	3.9K	1/10W	5%	RMC1/10T 392J	J24205392		
R 2113	CHIP RES.	470K	1/10W	5%	RMC1/10T 474J	J24205474		
R 2114	CHIP RES.	47K	1/10W	5%	RMC1/10T 473J	J24205473		
R 2115	CHIP RES.	47K	1/10W	5%	RMC1/10T 473J	J24205473		
R 2116	CHIP RES.	4.7K	1/10W	5%	RMC1/10T 472J	J24205472		
R 2117	CHIP RES.	47K	1/10W	5%	RMC1/10T 473J	J24205473		
R 2118	CHIP RES.	47K	1/10W	5%	RMC1/10T 473J	J24205473		
R 2119	CHIP RES.	4.7K	1/10W	5%	RMC1/10T 472J	J24205472		
R 2121	CHIP RES.	4.7K	1/10W	5%	RMC1/10T 472J	J24205472		
R 2122	CHIP RES.	47K	1/10W	5%	RMC1/10T 473J	J24205473		
R 2123	CHIP RES.	150K	1/10W	5%	RMC1/10T 154J	J24205154		
R 2124	CHIP RES.	47K	1/10W	5%	RMC1/10T 473J	J24205473		
R 2125	CHIP RES.	0	1/10W	5%	RMC1/10T 000J	J24205000		
R 2127	CHIP RES.	560	1/10W	5%	RMC1/10T 561J	J24205561		
R 2128	CHIP RES.	6.8K	1/10W	5%	RMC1/10T 682J	J24205682		
R 2129	CHIP RES.	4.7K	1/10W	5%	RMC1/10T 472J	J24205472		
R 2130	CHIP RES.	22K	1/10W	5%	RMC1/10T 223J	J24205223		
R 2131	CHIP RES.	47K	1/10W	5%	RMC1/10T 473J	J24205473		
R 2132	CHIP RES.	22K	1/10W	5%	RMC1/10T 223J	J24205223		
R 2133	CHIP RES.	10K	1/10W	5%	RMC1/10T 103J	J24205103		
R 2134	CHIP RES.	47K	1/10W	5%	RMC1/10T 473J	J24205473		
R 2135	CHIP RES.	22K	1/10W	5%	RMC1/10T 223J	J24205223		
R 2136	CHIP RES.	47K	1/10W	5%	RMC1/10T 473J	J24205473		
R 2137	CHIP RES.	22K	1/10W	5%	RMC1/10T 223J	J24205223		
R 2138	CHIP RES.	47K	1/10W	5%	RMC1/10T 473J	J24205473		
R 2139	CHIP RES.	33K	1/10W	5%	RMC1/10T 333J	J24205333		
R 2140	CHIP RES.	4.7K	1/10W	5%	RMC1/10T 472J	J24205472		
R 2141	CHIP RES.	2.2K	1/10W	5%	RMC1/10T 222J	J24205222		
R 2142	CHIP RES.	1K	1/10W	5%	RMC1/10T 102J	J24205102		
R 2143	CHIP RES.	4.7	1/10W	5%	RMC1/10T 4R7J	J24205479		
R 2144	CHIP RES.	2.2K	1/10W	5%	RMC1/10T 222J	J24205222		
R 2145	CHIP RES.	560	1/10W	5%	RMC1/10T 561J	J24205561		
R 2146	CHIP RES.	8.2K	1/10W	5%	RMC1/10T 822J	J24205822		

REF.	DESCRIPTION	VALUE	WV	TOL.	MFGR'S DESIG	YAESU P/N	VERS.	LOT.
R 2147	CHIP RES.	1K	1/10W	5%	RMC1/10T 102J	J24205102		
R 2148	CHIP RES.	220	1/10W	5%	RMC1/10T 221J	J24205221		
R 2149	CHIP RES.	10K	1/10W	5%	RMC1/10T 103J	J24205103		
R 2150	CHIP RES.	47K	1/10W	5%	RMC1/10T 473J	J24205473		
R 2151	CHIP RES.	47K	1/10W	5%	RMC1/10T 473J	J24205473		
R 2152	CHIP RES.	33K	1/10W	5%	RMC1/10T 333J	J24205333		
R 2153	CHIP RES.	4.7K	1/10W	5%	RMC1/10T 472J	J24205472		
R 2154	CHIP RES.	47K	1/10W	5%	RMC1/10T 473J	J24205473		
R 2155	CHIP RES.	4.7K	1/10W	5%	RMC1/10T 472J	J24205472		
R 2156	CHIP RES.	47K	1/10W	5%	RMC1/10T 473J	J24205473		
R 2157	CHIP RES.	47K	1/10W	5%	RMC1/10T 473J	J24205473		
R 2158	CHIP RES.	47K	1/10W	5%	RMC1/10T 473J	J24205473		
R 2159	CHIP RES.	4.7K	1/10W	5%	RMC1/10T 472J	J24205472		
R 2160	CHIP RES.	1.2K	1/10W	5%	RMC1/10T 122J	J24205122		
R 2161	CHIP RES.	47K	1/10W	5%	RMC1/10T 473J	J24205473		
R 2162	CHIP RES.	47K	1/10W	5%	RMC1/10T 473J	J24205473		
R 2163	CHIP RES.	1.2K	1/10W	5%	RMC1/10T 122J	J24205122		
R 2164	CHIP RES.	4.7K	1/10W	5%	RMC1/10T 472J	J24205472		
R 2165	CHIP RES.	4.7K	1/10W	5%	RMC1/10T 472J	J24205472		
R 2166	CHIP RES.	4.7K	1/10W	5%	RMC1/10T 472J	J24205472		
R 2177	CHIP RES.	4.7K	1/10W	5%	RMC1/10T 472J	J24205472		
R 2178	CHIP RES.	47K	1/10W	5%	RMC1/10T 473J	J24205473		
R 2179	CARBON FILM RES.	560	1/6W	5%	RD16PJ561	J01225561		
S 2001	SLIDE SWITCH				SSSS21	N6090069		
S 2003	SLIDE SWITCH				SSSF113-S06N1	N6090098		
S 2004	SLIDE SWITCH				SSSS21	N6090069		
S 2005	SLIDE SWITCH				SSSS21	N6090069		
S 2006	SLIDE SWITCH				SSSF122-S06N1	N6090099		
T 2001	TRANS.					L2190039		
T 2002	TRANS.					L2190039		
VR2001	POT.	10K			EVN-DCAA03B14	J50784103		
VR2002	POT.	10K			EVN-DCAA03B14	J50784103		
VR2003	POT.	10K			EVN-DCAA03B14	J50784103		
VR2004	POT.	5K			EVN-DCAA03B53	J50784502		
VR2005	POT.	10K			EVN-DCAA03B14	J50784103		
VR2006	POT.	10K			EVN-DCAA03B14	J50784103		
VR2007	POT.	10K			EVN-DCAA03B14	J50784103		

Circuit Diagram

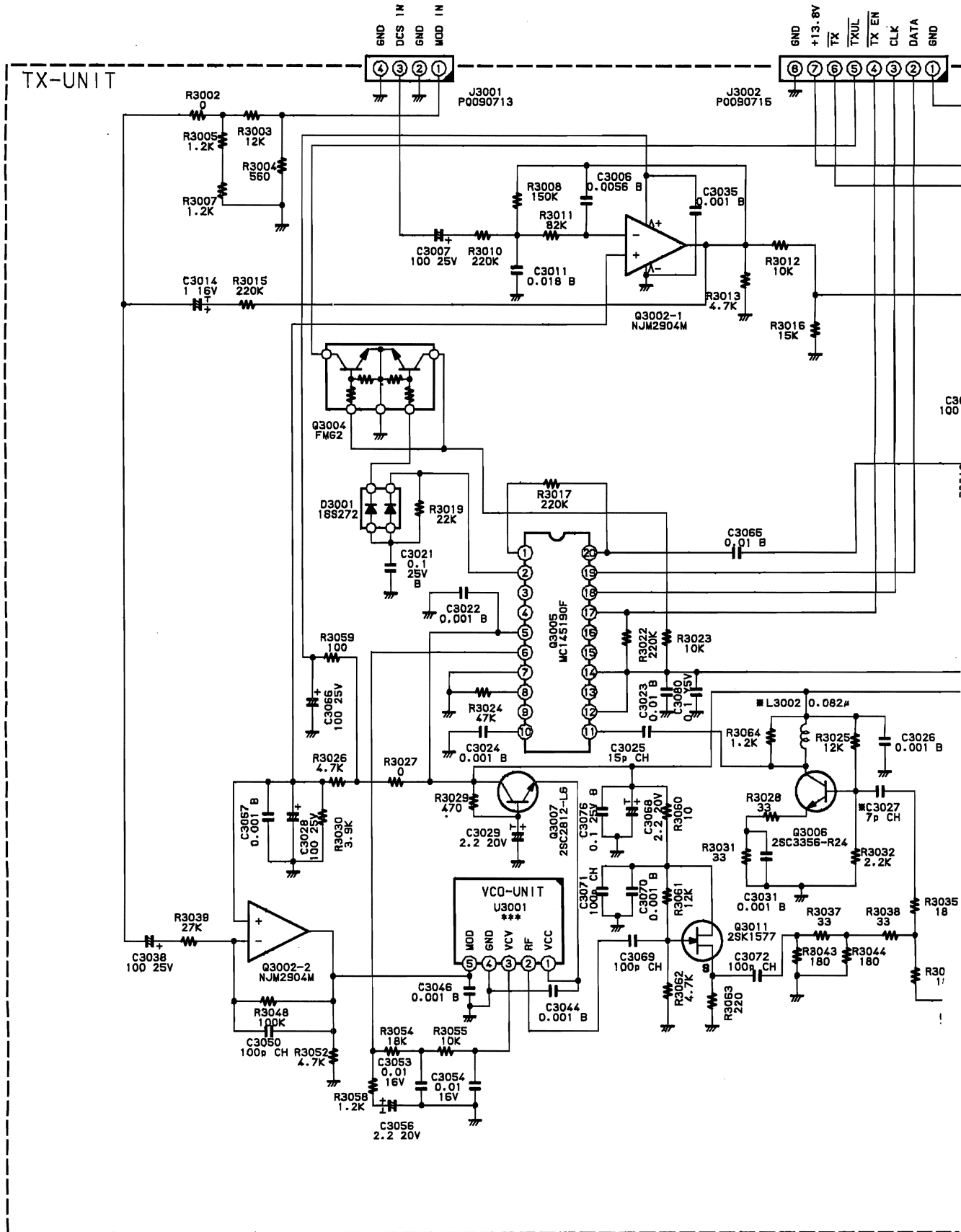

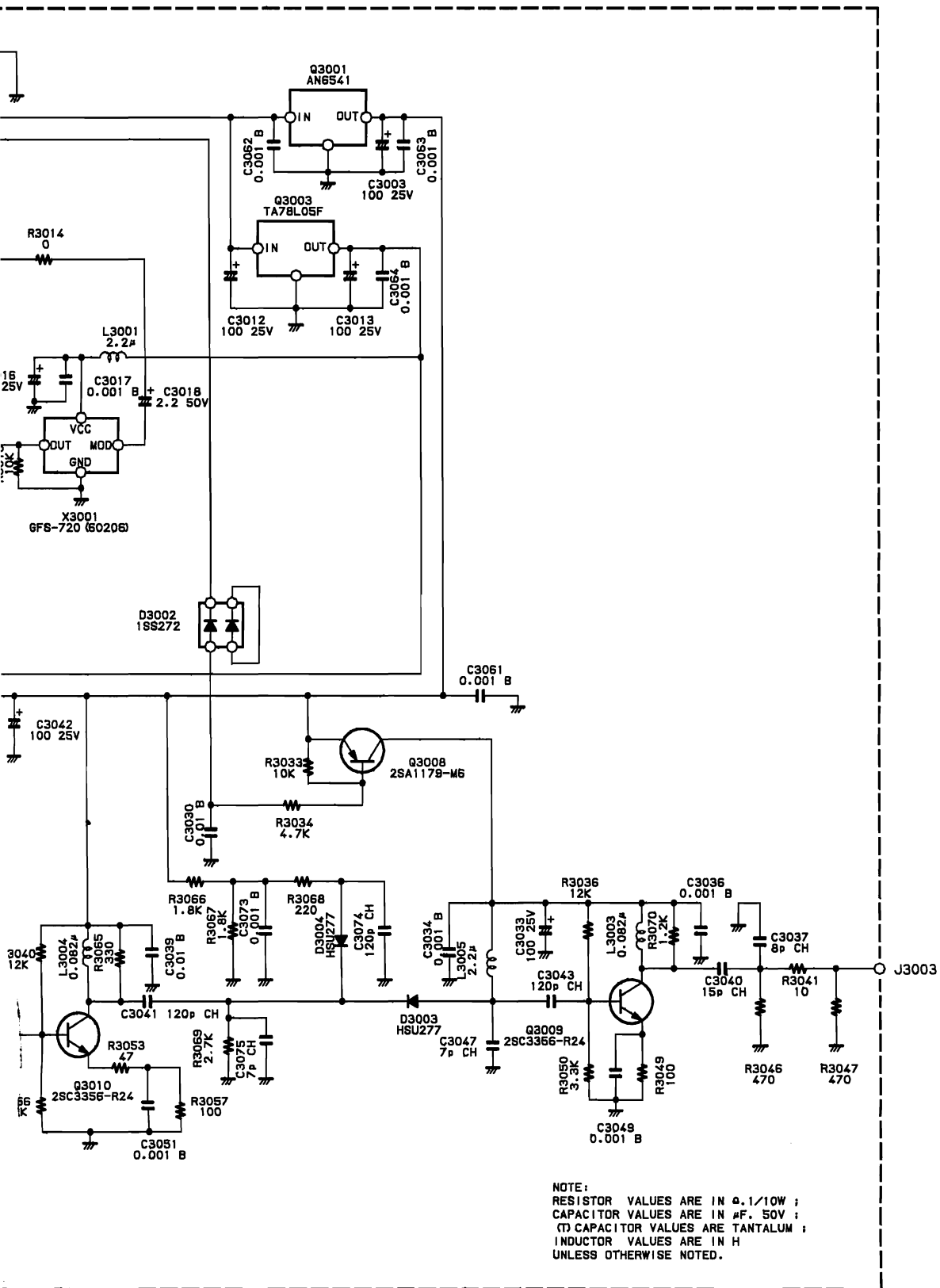

Parts Layout

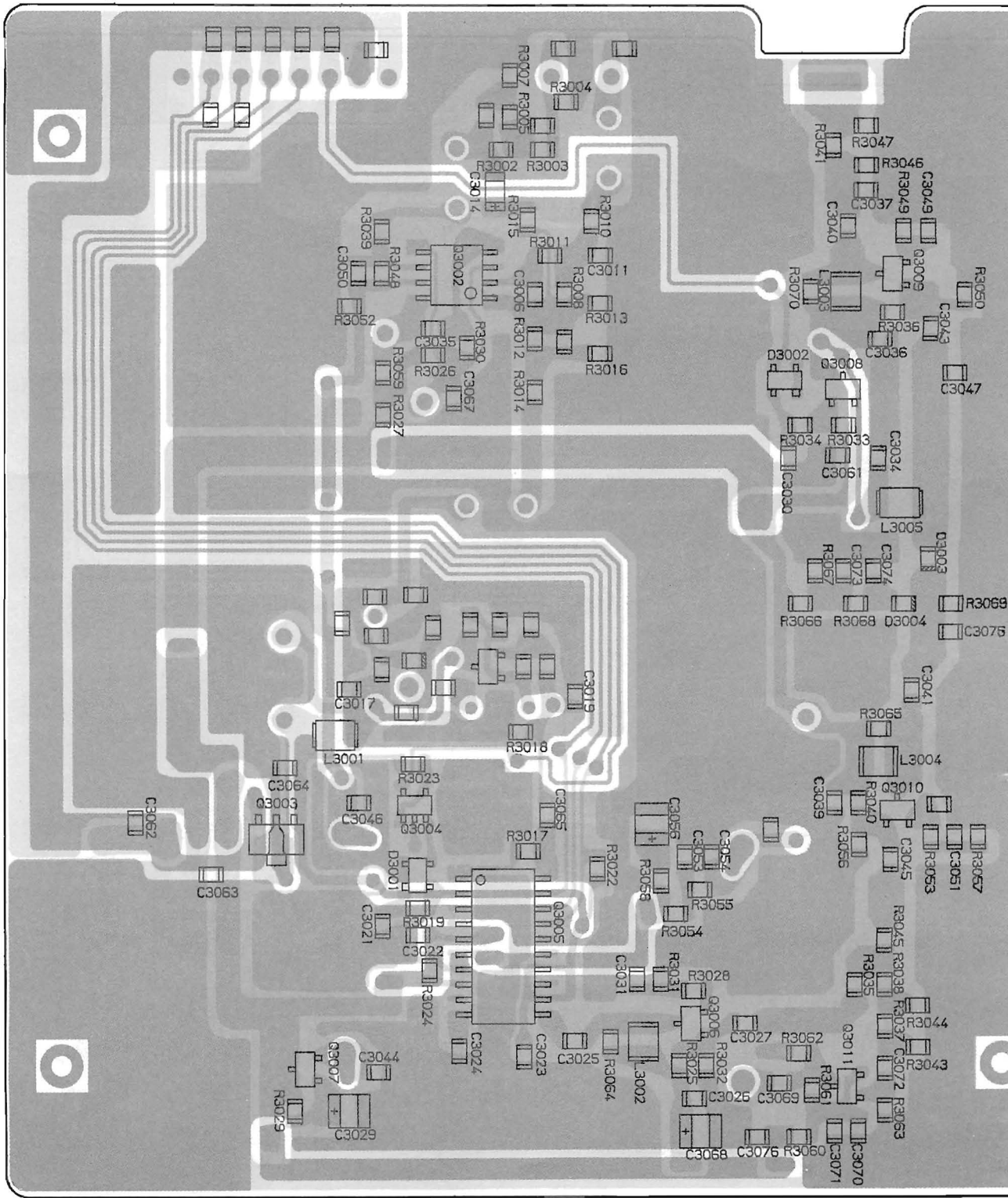

obverse view of chip

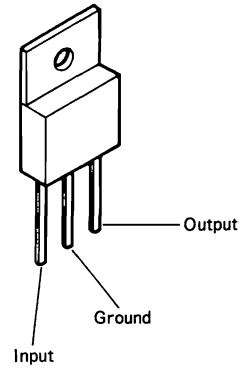

**AN6541
(Q3001)**

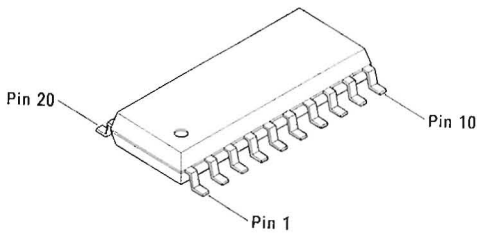

MC145190FER
(Q3005)

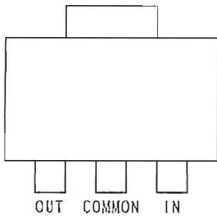

TA78L05F
(Q3003)

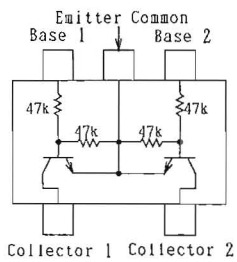

FMG2 (G2)
(Q3004)

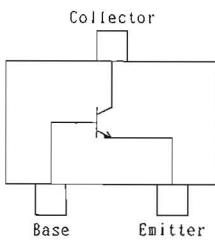

2SC2812 (L6)
(Q3007)
2SC3356 (R24)
(Q3006,3009,3010)

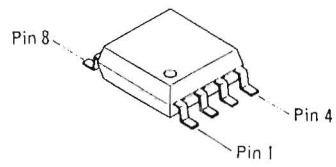

NJM2904M
(Q3002)

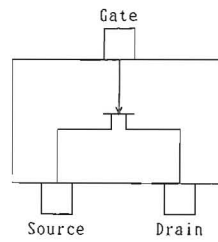

2SK1577 (P1)
(Q3011)

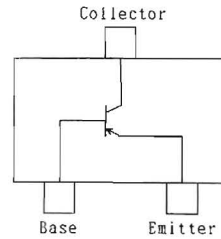

2SA1179 (M6)
(Q3008)

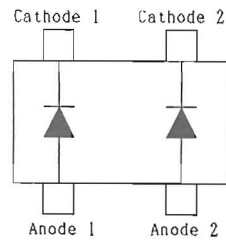

1SS272 (A1)
(D3001,3002)

side

REF.	DESCRIPTION	VALUE	WV	TOL.	MFGR'S DESIG	YAESU P/N	VERS.	LOT.	LAY	ADR
*** TX UNIT ***										
	PCB with Components					CA0970001	TYP BS1			
	(W/O TX VCO UNIT, J3003 CONNECTOR, SHIELD CASE					CA0970002	TYP A	6-		
	SHIELD FRAME, SPECIAL NUT(4pcs), LEAF SPRING)					CA0970003	TYP B	6-		
						CA0970004	TYP C	6-		
	PCB with Components					CS1291001	TYP BS1			
	(W/O J3003 CONNECTOR, SHIELD CASE, SHIELD FRAME,					CS1291002	TYP A	6-		
	SPECIAL NUT(4pcs), LEAF SPRING)					CS1291003	TYP B	6-		
						CS1291004	TYP C	6-		
	Printed Circuit Board					F3379000				
C 3003	AL. ELECTRO. CAP.	100uF	25V		25V101M6X11TR5	K46140005				
C 3006	CHIP CAP.	0.0056uF	50V	B	GRM40B562M50PT	K22170814				
C 3007	AL. ELECTRO. CAP.	100uF	25V		25V101M6X11TR5	K46140005				
C 3011	CHIP CAP.	0.018uF	50V	B	GRM40B183M50PT	K22170820				
C 3012	AL. ELECTRO. CAP.	100uF	25V		25V101M6X11TR5	K46140005				
C 3013	AL. ELECTRO. CAP.	100uF	25V		25V101M6X11TR5	K46140005				
C 3014	TANTALUM CHIP CAP.	1uF	16V		TESVA1C105M1-8R	K78120009				
C 3016	AL. ELECTRO. CAP.	100uF	25V		25V101M6X11TR5	K46140005				
C 3017	CHIP CAP.	0.001uF	50V	B	GRM40B102M50PT	K22170805				
C 3018	AL. ELECTRO. CAP.	2.2uF	50V		50V2R2M5X11TR5	K46170018				
C 3021	CHIP CAP.	0.1uF	25V	B	GRM40B104M25PT	K22140811				
C 3022	CHIP CAP.	0.001uF	50V	B	GRM40B102M50PT	K22170805				
C 3023	CHIP CAP.	0.01uF	50V	B	GRM40B103M50PT	K22170817				
C 3024	CHIP CAP.	0.001uF	50V	B	GRM40B102M50PT	K22170805				
C 3025	CHIP CAP.	15pF	50V	CH	GRM40CH150J50PT	K22170215				
C 3026	CHIP CAP.	0.001uF	50V	B	GRM40B102M50PT	K22170805				
C 3027	CHIP CAP.	2pF	50V	CK	GRM40CK020C50PT	K22170203	TYP A	6-		
C 3027	CHIP CAP.	7pF	50V	CH	GRM40CH070D50PT	K22170208	TYP B	6-		
C 3027	CHIP CAP.	7pF	50V	CH	GRM40CH070D50PT	K22170208	TYP BS1			
C 3027	CHIP CAP.	7pF	50V	CH	GRM40CH070D50PT	K22170208	TYP C	6-		
C 3028	AL. ELECTRO. CAP.	100uF	25V		25V101M6X11TR5	K46140005				
C 3029	TANTALUM CHIP CAP.	2.2uF	20V		TESVB21D225M8R	K78130010				
C 3030	CHIP CAP.	0.01uF	50V	B	GRM40B103M50PT	K22170817				
C 3031	CHIP CAP.	0.001uF	50V	B	GRM40B102M50PT	K22170805				
C 3033	AL. ELECTRO. CAP.	100uF	25V		25V101M6X11TR5	K46140005				
C 3034	CHIP CAP.	0.001uF	50V	B	GRM40B102M50PT	K22170805				
C 3035	CHIP CAP.	0.001uF	50V	B	GRM40B102M50PT	K22170805				
C 3036	CHIP CAP.	0.001uF	50V	B	GRM40B102M50PT	K22170805				
C 3037	CHIP CAP.	8pF	50V	CH	GRM40CH080D50PT	K22170209				
C 3038	AL. ELECTRO. CAP.	100uF	25V		25V101M6X11TR5	K46140005				
C 3039	CHIP CAP.	0.01uF	50V	B	GRM40B103M50PT	K22170817				
C 3040	CHIP CAP.	15pF	50V	CH	GRM40CH150J50PT	K22170215				
C 3041	CHIP CAP.	120pF	50V	CH	GRM40CH121J50PT	K22170237				
C 3042	AL. ELECTRO. CAP.	100uF	25V		25V101M6X11TR5	K46140005				
C 3043	CHIP CAP.	120pF	50V	CH	GRM40CH121J50PT	K22170237				
C 3044	CHIP CAP.	0.001uF	50V	B	GRM40B102M50PT	K22170805				
C 3045	CHIP CAP.	7pF	50V	CH	GRM40CH070D50PT	K22170208				
C 3046	CHIP CAP.	0.001uF	50V	B	GRM40B102M50PT	K22170805				
C 3047	CHIP CAP.	7pF	50V	CH	GRM40CH070D50PT	K22170208				
C 3049	CHIP CAP.	0.001uF	50V	B	GRM40B102M50PT	K22170805				

REF.	DESCRIPTION	VALUE	WV	TOL.	MFGR'S DESIG	YAESU P/N	VERS.	LOT.	LAY	ADR
C 3050	CHIP CAP.	100pF	50V	CH	GRM40CH101J50PT	K22170235				
C 3051	CHIP CAP.	0.001uF	50V	B	GRM40B102M50PT	K22170805				
C 3053	FILM CAP.	0.01uF	16V		ECHU1C103JB5	K57120007				
C 3054	FILM CAP.	0.01uF	16V		ECHU1C103JB5	K57120007				
C 3056	TANTALUM CHIP CAP.	2.2uF	20V		TESVB21D225M8R	K78130010				
C 3061	CHIP CAP.	0.001uF	50V	B	GRM40B102M50PT	K22170805				
C 3062	CHIP CAP.	0.001uF	50V	B	GRM40B102M50PT	K22170805				
C 3063	CHIP CAP.	0.001uF	50V	B	GRM40B102M50PT	K22170805				
C 3064	CHIP CAP.	0.001uF	50V	B	GRM40B102M50PT	K22170805				
C 3065	CHIP CAP.	0.01uF	50V	B	GRM40B103M50PT	K22170817				
C 3066	AL. ELECTRO. CAP.	100uF	25V		25V101M6X11TR5	K46140005				
C 3067	CHIP CAP.	0.001uF	50V	B	GRM40B102M50PT	K22170805				
C 3068	TANTALUM CHIP CAP.	2.2uF	20V		TESVB21D225M8R	K78130010				
C 3069	CHIP CAP.	100pF	50V	CH	GRM40CH101J50PT	K22170235				
C 3070	CHIP CAP.	0.001uF	50V	B	GRM40B102M50PT	K22170805				
C 3071	CHIP CAP.	100pF	50V	CH	GRM40CH101J50PT	K22170235				
C 3072	CHIP CAP.	100pF	50V	CH	GRM40CH101J50PT	K22170235				
C 3073	CHIP CAP.	0.001uF	50V	B	GRM40B102M50PT	K22170805				
C 3074	CHIP CAP.	120pF	50V	CH	GRM40CH121J50PT	K22170237				
C 3075	CHIP CAP.	7pF	50V	CH	GRM40CH070D50PT	K22170208				
C 3076	CHIP CAP.	0.1uF	25V	B	GRM40B104M25PT	K22140811				
C 3080	CERAMIC CAP.	0.1uF	50V	Y5V	D33Y5V1H104Z51	K23170032				
D 3001	DIODE				1SS272 TE85R	G2070048				
D 3002	DIODE				1SS272 TE85R	G2070048				
D 3003	DIODE				HSU277	G2070118				
D 3004	DIODE				HSU277	G2070118				
J 3001	CONNECTOR				SC25-04WL	P0090713				
J 3002	CONNECTOR				SC25-08WL	P0090715				
J 3003	CONNECTOR				BNC-RM-1 (W/O LUG)	P1090773A				
L 3001	M. RFC	2.2uH			FLC32T-2R2K	L1690207				
L 3002	CHIP COIL	0.22uH			LQN2A822K	L1690003	TYP A	6-		
L 3002	CHIP COIL	0.082uH			LQN2A82NM	L1690010	TYP B	6-		
L 3002	CHIP COIL	0.082uH			LQN2A82NM	L1690010	TYP BS1			
L 3002	CHIP COIL	0.082uH			LQN2A82NM	L1690010	TYP C	6-		
L 3003	CHIP COIL	0.082uH			LQN2A82NM	L1690010				
L 3004	CHIP COIL	0.082uH			LQN2A82NM	L1690010				
L 3005	M. RFC	2.2uH			FLC32T-2R2K	L1690207				
Q 3001	IC				AN6541	G1091146				
Q 3002	IC				NJM2904M-T2	G1091374				
Q 3003	IC				TA78L05F TE12R	G1091014				
Q 3004	TRANSISTOR				FMG2 T99	G3070015				
Q 3005	IC				MC145190FER	G1091621				
Q 3006	TRANSISTOR				2SC3356-T2B R24	G3333567D				
Q 3007	TRANSISTOR				2SC2812L6-TA	G3328127F				
Q 3008	TRANSISTOR				2SA1179M6-TA	G3111797F				
Q 3009	TRANSISTOR				2SC3356-T2B R24	G3333567D				
Q 3010	TRANSISTOR				2SC3356-T2B R24	G3333567D				
Q 3011	FET				2SK1577	G3815777				
R 3002	CHIP RES.	0	1/10W	5%	RMC1/10T 000J	J24205000				

REF.	DESCRIPTION	VALUE	WV	TOL	MFGR'S DESIG	YAESU P/N	VERS.	LOT.	LAY	ADR
R 3003	CHIP RES.	12K	1/10W	5%	RMC1/10T 123J	J24205123				
R 3004	CHIP RES.	560	1/10W	5%	RMC1/10T 561J	J24205561				
R 3005	CHIP RES.	1.2K	1/10W	5%	RMC1/10T 122J	J24205122				
R 3007	CHIP RES.	1.2K	1/10W	5%	RMC1/10T 122J	J24205122				
R 3008	CHIP RES.	150K	1/10W	5%	RMC1/10T 154J	J24205154				
R 3010	CHIP RES.	220K	1/10W	5%	RMC1/10T 224J	J24205224				
R 3011	CHIP RES.	82K	1/10W	5%	RMC1/10T 823J	J24205823				
R 3012	CHIP RES.	10K	1/10W	5%	RMC1/10T 103J	J24205103				
R 3013	CHIP RES.	4.7K	1/10W	5%	RMC1/10T 472J	J24205472				
R 3014	CHIP RES.	0	1/10W	5%	RMC1/10T 000J	J24205000				
R 3015	CHIP RES.	220K	1/10W	5%	RMC1/10T 224J	J24205224				
R 3016	CHIP RES.	15K	1/10W	5%	RMC1/10T 153J	J24205153				
R 3017	CHIP RES.	220K	1/10W	5%	RMC1/10T 224J	J24205224				
R 3018	CHIP RES.	10K	1/10W	5%	RMC1/10T 103J	J24205103				
R 3019	CHIP RES.	22K	1/10W	5%	RMC1/10T 223J	J24205223				
R 3022	CHIP RES.	220K	1/10W	5%	RMC1/10T 224J	J24205224				
R 3023	CHIP RES.	10K	1/10W	5%	RMC1/10T 103J	J24205103				
R 3024	CHIP RES.	47K	1/10W	5%	RMC1/10T 473J	J24205473				
R 3025	CHIP RES.	12K	1/10W	5%	RMC1/10T 123J	J24205123				
R 3026	CHIP RES.	4.7K	1/10W	5%	RMC1/10T 472J	J24205472				
R 3027	CHIP RES.	0	1/10W	5%	RMC1/10T 000J	J24205000				
R 3028	CHIP RES.	33	1/10W	5%	RMC1/10T 330J	J24205330				
R 3029	CHIP RES.	470	1/10W	5%	RMC1/10T 471J	J24205471				
R 3030	CHIP RES.	3.9K	1/10W	5%	RMC1/10T 392J	J24205392				
R 3031	CHIP RES.	33	1/10W	5%	RMC1/10T 330J	J24205330				
R 3032	CHIP RES.	2.2K	1/10W	5%	RMC1/10T 222J	J24205222				
R 3033	CHIP RES.	10K	1/10W	5%	RMC1/10T 103J	J24205103				
R 3034	CHIP RES.	4.7K	1/10W	5%	RMC1/10T 472J	J24205472				
R 3035	CHIP RES.	18	1/10W	5%	RMC1/10T 180J	J24205180				
R 3036	CHIP RES.	12K	1/10W	5%	RMC1/10T 123J	J24205123				
R 3037	CHIP RES.	33	1/10W	5%	RMC1/10T 330J	J24205330				
R 3038	CHIP RES.	33	1/10W	5%	RMC1/10T 330J	J24205330				
R 3039	CHIP RES.	27K	1/10W	5%	RMC1/10T 273J	J24205273				
R 3040	CHIP RES.	12K	1/10W	5%	RMC1/10T 123J	J24205123				
R 3041	CHIP RES.	10	1/10W	5%	RMC1/10T 100J	J24205100				
R 3043	CHIP RES.	180	1/10W	5%	RMC1/10T 181J	J24205181				
R 3044	CHIP RES.	180	1/10W	5%	RMC1/10T 181J	J24205181				
R 3045	CHIP RES.	18	1/10W	5%	RMC1/10T 180J	J24205180				
R 3046	CHIP RES.	470	1/10W	5%	RMC1/10T 471J	J24205471				
R 3047	CHIP RES.	470	1/10W	5%	RMC1/10T 471J	J24205471				
R 3048	CHIP RES.	100K	1/10W	5%	RMC1/10T 104J	J24205104				
R 3049	CHIP RES.	100	1/10W	5%	RMC1/10T 101J	J24205101				
R 3050	CHIP RES.	3.3K	1/10W	5%	RMC1/10T 332J	J24205332				
R 3052	CHIP RES.	4.7K	1/10W	5%	RMC1/10T 472J	J24205472				
R 3053	CHIP RES.	47	1/10W	5%	RMC1/10T 470J	J24205470				
R 3054	CHIP RES.	18K	1/10W	5%	RMC1/10T 183J	J24205183				
R 3055	CHIP RES.	10K	1/10W	5%	RMC1/10T 103J	J24205103				
R 3056	CHIP RES.	2.2K	1/10W	5%	RMC1/10T 222J	J24205222				
R 3057	CHIP RES.	100	1/10W	5%	RMC1/10T 101J	J24205101				
R 3058	CHIP RES.	1.2K	1/10W	5%	RMC1/10T 122J	J24205122				
R 3059	CHIP RES.	100	1/10W	5%	RMC1/10T 101J	J24205101				
R 3060	CHIP RES.	10	1/10W	5%	RMC1/10T 100J	J24205100				
R 3061	CHIP RES.	12K	1/10W	5%	RMC1/10T 123J	J24205123				
R 3062	CHIP RES.	4.7K	1/10W	5%	RMC1/10T 472J	J24205472				

REF.	DESCRIPTION	VALUE	WV	TOL.	MFGR'S DESIG	YAESU P/N	VERS.	LOT.	LAY ADR
R 3063	CHIP RES.	220	1/10W	5%	RMC1/10T 221J	J24205221			
R 3064	CHIP RES.	1.2K	1/10W	5%	RMC1/10T 122J	J24205122			
R 3065	CHIP RES.	330	1/10W	5%	RMC1/10T 331J	J24205331			
R 3066	CHIP RES.	1.8K	1/10W	5%	RMC1/10T 182J	J24205182			
R 3067	CHIP RES.	1.8K	1/10W	5%	RMC1/10T 182J	J24205182			
R 3068	CHIP RES.	220	1/10W	5%	RMC1/10T 221J	J24205221			
R 3069	CHIP RES.	2.7K	1/10W	5%	RMC1/10T 272J	J24205272			
R 3070	CHIP RES.	1.2K	1/10W	5%	RMC1/10T 122J	J24205122			
X 3001	XTAL				GFS-720(60206)	H9500210			
	LEAF SPRING					R0136330A			
	SHIELD FRAME					R0147200			
	SHIELD CASE					R0519070A			
	SPECIAL NUT (4pcs)					R6068590			

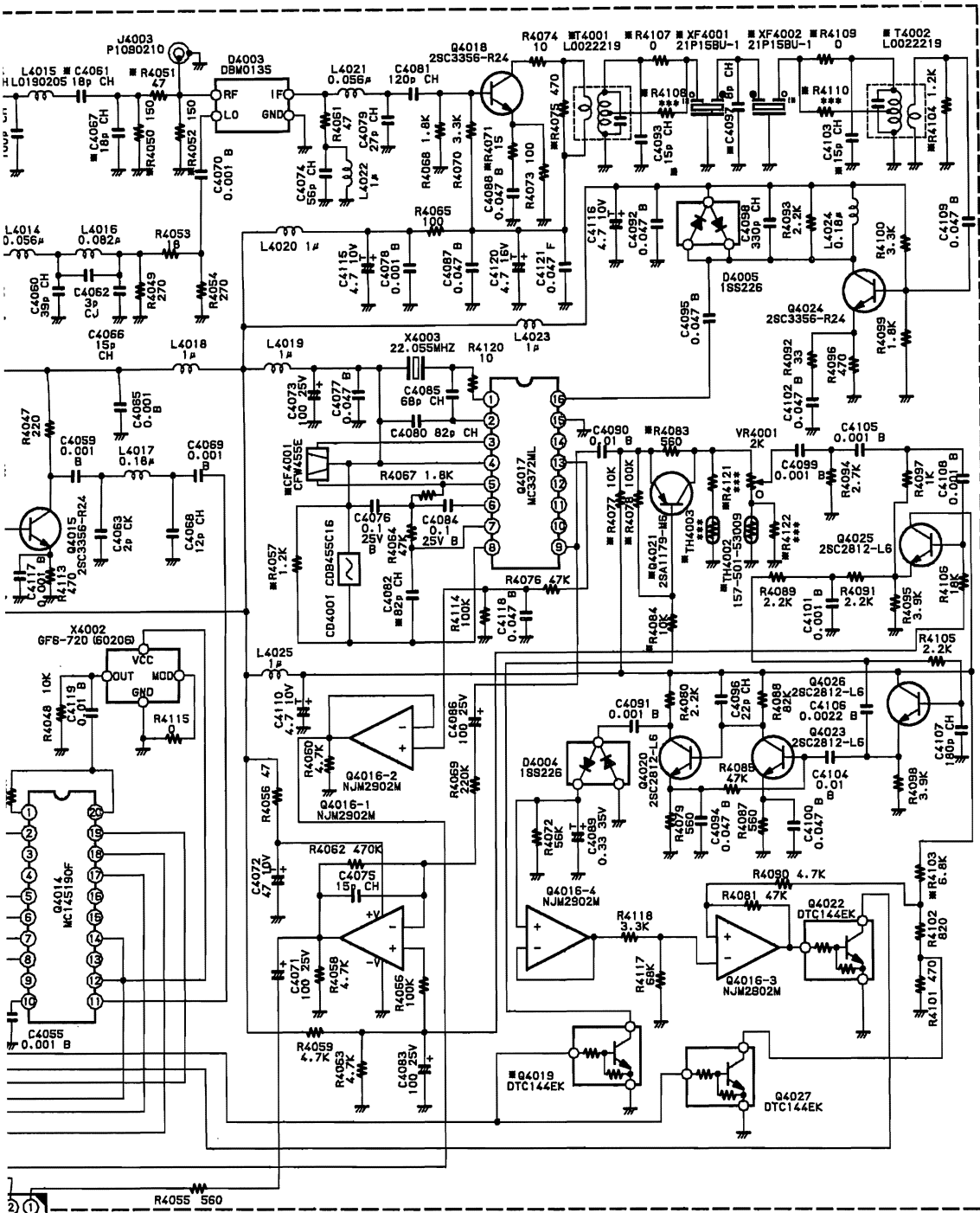

J4002 P0050712

GND		D18C OUT	
20K	12.5K		
100K	-		
560	680		
10K	-		
6.8K	3.3K		
1.5K	1.5K		
0	-		
-	0		

	25K	20K	12.5K
R4109	0	0	-
R4110	-	-	0
R4121	-	-	390
R4122	-	-	0
C4082	82P	82P	120P
C4093	15P	15P	8P
C4097	8P	9P	18P
C4103	15P	15P	8P
CF4001	CFW455E	CFW455F	CFW455G

	25K	20K	12.5K
Q4019	DTC144EK	DTC144EK	-
Q4021	2SA1179	2SA1179	-
XF4001	21P15BU-1	21P12BU-1	21P8BU-1
XF4002	21P15BU-1	21P12BU-1	21P8BU-1

	25K	20K	12.5K
TH4002	157-501	157-501	-
TH4003	-	-	157-501
T4001	L0022219	L0022219	L0022174
T4002	L0022219	L0022219	L0022174

obverse view of chip

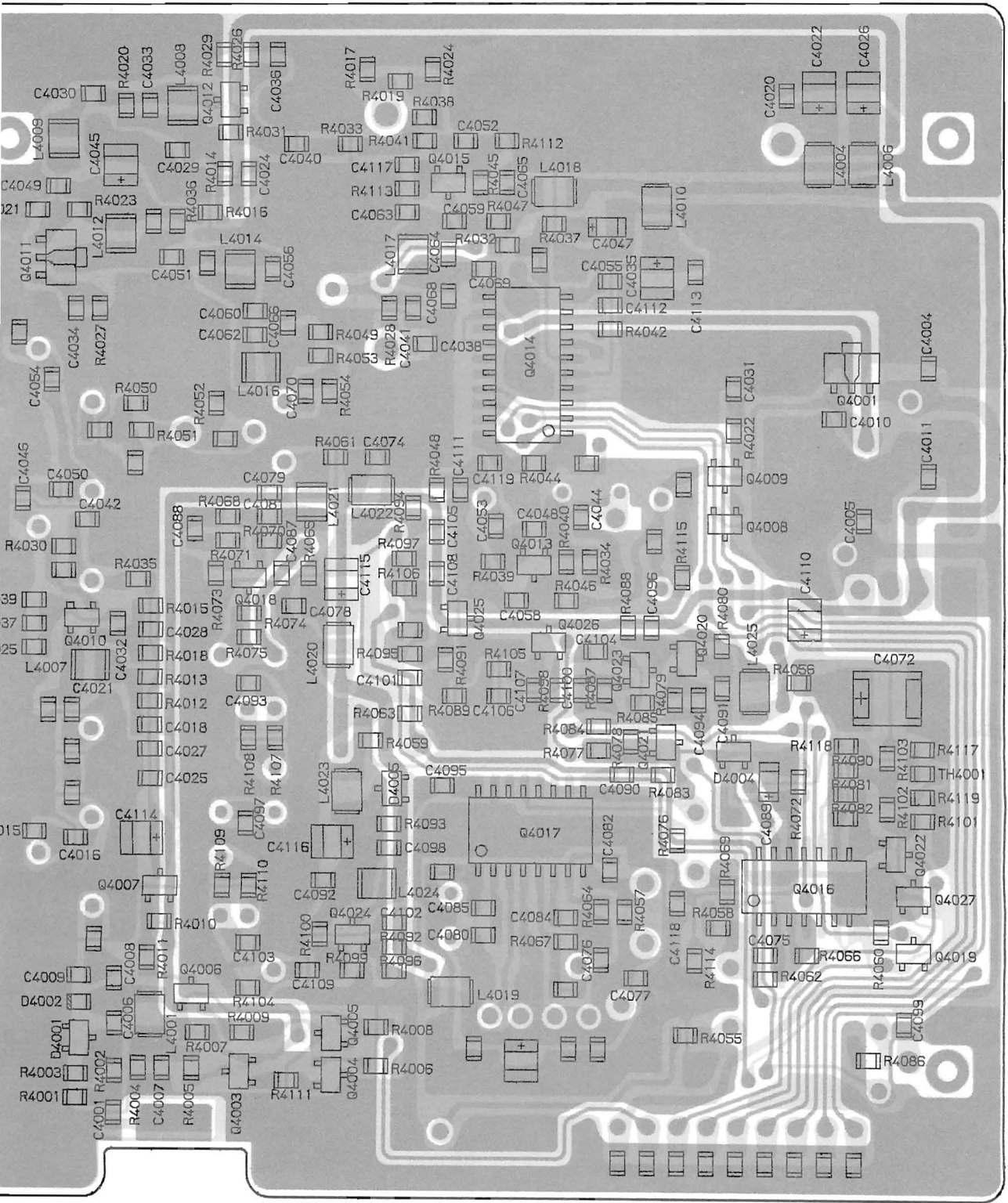

Parts Layout

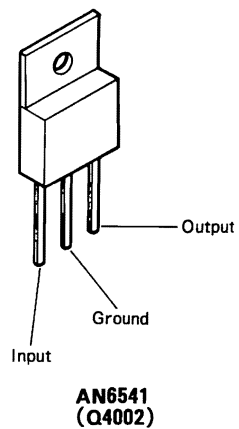
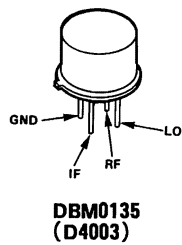

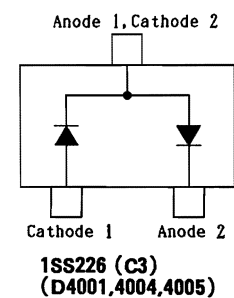
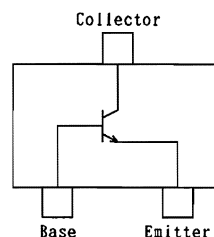
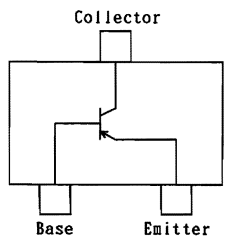
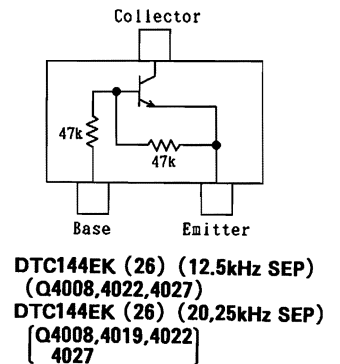
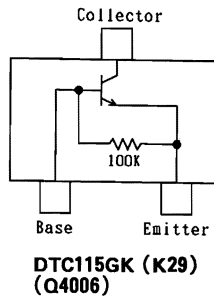
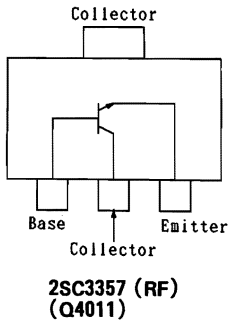
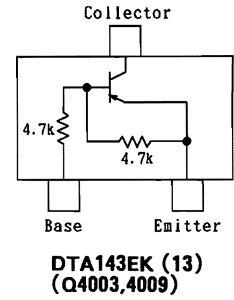
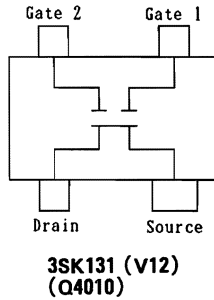
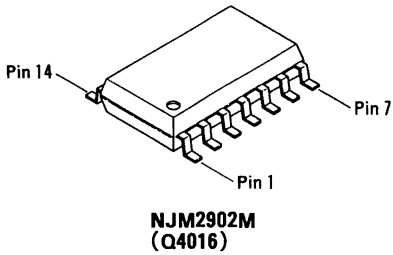
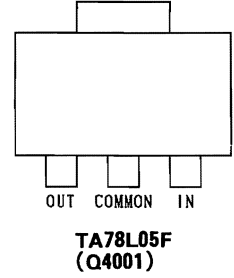
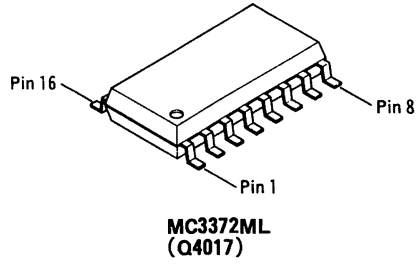
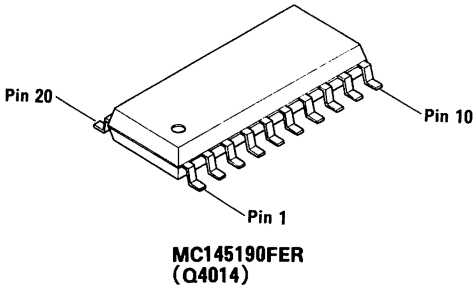

side

REF.	DESCRIPTION	VALUE	WV	TOL.	MFGR'S DESIG	YAESU P/N	VERS.	LOT.	LAY	ADR
*** RX UNIT ***										
	PCB with Components					CA1031001	BS1, 25K			
	(W/O RX VCO UNIT, J4003 CONNECTOR, SHIELD CASE,					CA1031002	BS1, 20K	5-		
	SHIELD FRAME, SHIELD COVER, SPECIAL NUT(4pcs),					CA1031003	BS1, 12.5K	5-		
	STICK FINGER(3pcs))					CA1031004	A, 25K	6-		
						CA1031005	A, 20K	6-		
						CA1031006	A, 12.5K	6-		
						CA1031007	B, 25K	6-		
						CA1031008	B, 20K	6-		
						CA1031009	B, 12.5K	6-		
						CA1031010	C, 25K	6-		
						CA1031011	C, 20K	6-		
						CA1031012	C, 12.5K	6-		
	PCB with Components					CS1292001	BS1, 25K			
	(W/O J4003 CONNECTOR, SHIELD CASE, SHIELD FRAME,					CS1292002	BS1, 20K	5-		
	SHIELD COVER, SPECIAL NUT(4pcs), STICK FINGER(3pcs))					CS1292003	BS1, 12.5K	5-		
						CS1292004	A, 25K	6-		
						CS1292005	A, 20K	6-		
						CS1292006	A, 12.5K	6-		
						CS1292007	B, 25K	6-		
						CS1292008	B, 20K	6-		
						CS1292009	B, 12.5K	6-		
						CS1292010	C, 25K	6-		
						CS1292011	C, 20K	6-		
						CS1292012	C, 12.5K	6-		
	Printed Circuit Board					F3380000				
C 4001	CHIP CAP.	0.001uF	50V	B	GRM40B102M50PT	K22170805				
C 4002	AL. ELECTRO. CAP.	100uF	25V		25V101M6X11TR5	K46140005				
C 4003	AL. ELECTRO. CAP.	100uF	25V		25V101M6X11TR5	K46140005				
C 4004	CHIP CAP.	0.001uF	50V	B	GRM40B102M50PT	K22170805				
C 4005	CHIP CAP.	0.001uF	50V	B	GRM40B102M50PT	K22170805				
C 4006	CHIP CAP.	0.001uF	50V	B	GRM40B102M50PT	K22170805				
C 4007	CHIP CAP.	0.001uF	50V	B	GRM40B102M50PT	K22170805				
C 4008	CHIP CAP.	0.001uF	50V	B	GRM40B102M50PT	K22170805				
C 4009	CHIP CAP.	56pF	50V	CH	GRM40CH560J50PT	K22170229	TYP A	6-		
C 4009	CHIP CAP.	22pF	50V	CH	GRM40CH220J50PT	K22170219	TYP B	6-		
C 4009	CHIP CAP.	22pF	50V	CH	GRM40CH220J50PT	K22170219	TYP BS1			
C 4009	CHIP CAP.	18pF	50V	CH	GRM40CH180J50PT	K22170217	TYP C	6-		
C 4010	CHIP CAP.	0.001uF	50V	B	GRM40B102M50PT	K22170805				
C 4011	CHIP CAP.	0.001uF	50V	B	GRM40B102M50PT	K22170805				
C 4012	CHIP CAP.	22pF	50V	CH	GRM40CH220J50PT	K22170219	TYP A	6-		
C 4012	CHIP CAP.	22pF	50V	CH	GRM40CH220J50PT	K22170219	TYP B	6-		
C 4012	CHIP CAP.	18pF	50V	CH	GRM40CH180J50PT	K22170217	TYP BS1			
C 4012	CHIP CAP.	18pF	50V	CH	GRM40CH180J50PT	K22170217	TYP C	6-		
C 4013	AL. ELECTRO. CAP.	100uF	25V		25V101M6X11TR5	K46140005				
C 4014	AL. ELECTRO. CAP.	100uF	25V		25V101M6X11TR5	K46140005				
C 4015	CHIP CAP.	270pF	50V	CH	GRM40CH271J50PT	K22170245	TYP A	6-		
C 4015	CHIP CAP.	220pF	50V	CH	GRM40CH221J50PT	K22170243	TYP B	6-		
C 4015	CHIP CAP.	220pF	50V	CH	GRM40CH221J50PT	K22170243	TYP BS1			
C 4015	CHIP CAP.	220pF	50V	CH	GRM40CH221J50PT	K22170243	TYP C	6-		

REF.	DESCRIPTION	VALUE	WV	TOL.	MFGR'S DESIG	YAESU P/N	VERS.	LOT.	LAY	ADR
C 4016	CHIP CAP.	18pF	50V	CH	GRM40CH180J50PT	K22170217	TYP A	6-		
C 4016	CHIP CAP.	12pF	50V	CH	GRM40CH120J50PT	K22170213	TYP B	6-		
C 4016	CHIP CAP.	12pF	50V	CH	GRM40CH120J50PT	K22170213	TYP BS1			
C 4016	CHIP CAP.	12pF	50V	CH	GRM40CH120J50PT	K22170213	TYP C	6-		
C 4017	CHIP CAP.	1pF	50V	CK	GRM40CK010C50PT	K22170202	TYP A	6-		
C 4017	CHIP CAP.	0.5pF	50V	CK	GRM40CK0R5C50PT	K22170201	TYP B	6-		
C 4017	CHIP CAP.	0.5pF	50V	CK	GRM40CK0R5C50PT	K22170201	TYP BS1			
C 4017	CHIP CAP.	0.5pF	50V	CK	GRM40CK0R5C50PT	K22170201	TYP C	6-		
C 4018	CHIP CAP.	0.001uF	50V	B	GRM40B102M50PT	K22170805				
C 4019	CHIP CAP.	1pF	50V	CK	GRM40CK010C50PT	K22170202	TYP A	6-		
C 4019	CHIP CAP.	2pF	50V	CK	GRM40CK020C50PT	K22170203	TYP B	6-		
C 4019	CHIP CAP.	2pF	50V	CK	GRM40CK020C50PT	K22170203	TYP BS1			
C 4019	CHIP CAP.	2pF	50V	CK	GRM40CK020C50PT	K22170203	TYP C	6-		
C 4020	CHIP CAP.	0.001uF	50V	B	GRM40B102M50PT	K22170805				
C 4021	CHIP CAP.	33pF	50V	CH	GRM40CH330J50PT	K22170223	TYP A	6-		
C 4021	CHIP CAP.	22pF	50V	CH	GRM40CH220J50PT	K22170219	TYP B	6-		
C 4021	CHIP CAP.	22pF	50V	CH	GRM40CH220J50PT	K22170219	TYP BS1			
C 4021	CHIP CAP.	22pF	50V	CH	GRM40CH220J50PT	K22170219	TYP C	6-		
C 4022	TANTALUM CHIP CAP.	4.7uF	10V		TESVB21A475M8R	K78100010				
C 4023	CHIP CAP.	27pF	50V	CH	GRM40CH270J50PT	K22170221	TYP A	6-		
C 4023	CHIP CAP.	22pF	50V	CH	GRM40CH220J50PT	K22170219	TYP B	6-		
C 4023	CHIP CAP.	18pF	50V	CH	GRM40CH180J50PT	K22170217	TYP BS1			
C 4023	CHIP CAP.	18pF	50V	CH	GRM40CH180J50PT	K22170217	TYP C	6-		
C 4024	CHIP CAP.	0.001uF	50V	B	GRM40B102M50PT	K22170805				
C 4025	CHIP CAP.	0.001uF	50V	B	GRM40B102M50PT	K22170805				
C 4026	TANTALUM CHIP CAP.	4.7uF	10V		TESVB21A475M8R	K78100010				
C 4027	CHIP CAP.	0.001uF	50V	B	GRM40B102M50PT	K22170805				
C 4028	CHIP CAP.	0.001uF	50V	B	GRM40B102M50PT	K22170805				
C 4029	CHIP CAP.	0.001uF	50V	B	GRM40B102M50PT	K22170805				
C 4030	CHIP CAP.	100pF	50V	CH	GRM40CH101J50PT	K22170235				
C 4031	CHIP CAP.	0.01uF	50V	B	GRM40B103M50PT	K22170817				
C 4032	CHIP CAP.	0.001uF	50V	B	GRM40B102M50PT	K22170805				
C 4033	CHIP CAP.	18pF	50V	CH	GRM40CH180J50PT	K22170217				
C 4034	CHIP CAP.	0.001uF	50V	B	GRM40B102M50PT	K22170805				
C 4035	TANTALUM CHIP CAP.	4.7uF	10V		TESVB21A475M8R	K78100010				
C 4036	CHIP CAP.	0.001uF	50V	B	GRM40B102M50PT	K22170805				
C 4037	CHIP CAP.	0.001uF	50V	B	GRM40B102M50PT	K22170805				
C 4038	FILM CAP.	0.01uF	16V		ECHU1C103JB5	K57120007				
C 4039	CHIP CAP.	0.001uF	50V	B	GRM40B102M50PT	K22170805				
C 4040	CHIP CAP.	3pF	50V	CJ	GRM40CJ030C50PT	K22170204				
C 4041	FILM CAP.	0.0047uF	16V		ECHU1C472JB5	K57120003				
C 4042	CHIP CAP.	0.001uF	50V	B	GRM40B102M50PT	K22170805				
C 4043	CHIP CAP.	12pF	50V	CH	GRM40CH120J50PT	K22170213	TYP A	6-		
C 4043	CHIP CAP.	8pF	50V	CH	GRM40CH080D50PT	K22170209	TYP B	6-		
C 4043	CHIP CAP.	7pF	50V	CH	GRM40CH070D50PT	K22170208	TYP BS1			
C 4043	CHIP CAP.	7pF	50V	CH	GRM40CH070D50PT	K22170208	TYP C	6-		
C 4045	CHIP CAP.	22pF	50V	CH	GRM40CH220J50PT	K22170219				
C 4046	CHIP CAP.	2pF	50V	CK	GRM40CK020C50PT	K22170203	TYP A	6-		
C 4046	CHIP CAP.	1pF	50V	CK	GRM40CK010C50PT	K22170202	TYP B	6-		
C 4046	CHIP CAP.	1pF	50V	CK	GRM40CK010C50PT	K22170202	TYP BS1			
C 4046	CHIP CAP.	1pF	50V	CK	GRM40CK010C50PT	K22170202	TYP C	6-		
C 4047	TANTALUM CHIP CAP.	0.33uF	35V		TESVA1V334M1-8R	K78160028				
C 4049	CHIP CAP.	0.001uF	50V	B	GRM40B102M50PT	K22170805				
C 4050	CHIP CAP.	2pF	50V	CK	GRM40CK020C50PT	K22170203				

REF.	DESCRIPTION	VALUE	WV	TOL.	MFGR'S DESIG	YAESU P/N	VERS.	LOT.	LAY	ADR
C 4051	CHIP CAP.	100pF	50V	CH	GRM40CH101J50PT	K22170235				
C 4052	CHIP CAP.	0.001uF	50V	B	GRM40B102M50PT	K22170805				
C 4054	CHIP CAP.	18pF	50V	CH	GRM40CH180J50PT	K22170217	TYP A	6-		
C 4054	CHIP CAP.	12pF	50V	CH	GRM40CH120J50PT	K22170213	TYP B	6-		
C 4054	CHIP CAP.	12pF	50V	CH	GRM40CH120J50PT	K22170213	TYP BS1			
C 4054	CHIP CAP.	12pF	50V	CH	GRM40CH120J50PT	K22170213	TYP C	6-		
C 4055	CHIP CAP.	0.001uF	50V	B	GRM40B102M50PT	K22170805				
C 4056	CHIP CAP.	33pF	50V	CH	GRM40CH330J50PT	K22170223				
C 4057	CHIP CAP.	120pF	50V	CH	GRM40CH121J50PT	K22170237	TYP A	6-		
C 4057	CHIP CAP.	120pF	50V	CH	GRM40CH121J50PT	K22170237	TYP B	6-		
C 4057	CHIP CAP.	100pF	50V	CH	GRM40CH101J50PT	K22170235	TYP BS1			
C 4057	CHIP CAP.	100pF	50V	CH	GRM40CH101J50PT	K22170235	TYP C	6-		
C 4059	CHIP CAP.	0.001uF	50V	B	GRM40B102M50PT	K22170805				
C 4060	CHIP CAP.	39pF	50V	CH	GRM40CH390J50PT	K22170225				
C 4061	CHIP CAP.	47pF	50V	CH	GRM40CH470J50PT	K22170227	TYP A	6-		
C 4061	CHIP CAP.	22pF	50V	CH	GRM40CH220J50PT	K22170219	TYP B	6-		
C 4061	CHIP CAP.	18pF	50V	CH	GRM40CH180J50PT	K22170217	TYP BS1			
C 4061	CHIP CAP.	18pF	50V	CH	GRM40CH180J50PT	K22170217	TYP C	6-		
C 4062	CHIP CAP.	3pF	50V	CJ	GRM40CJ030C50PT	K22170204				
C 4063	CHIP CAP.	2pF	50V	CK	GRM40CK020C50PT	K22170203				
C 4065	CHIP CAP.	0.001uF	50V	B	GRM40B102M50PT	K22170805				
C 4066	CHIP CAP.	15pF	50V	CH	GRM40CH150J50PT	K22170215				
C 4067	CHIP CAP.	22pF	50V	CH	GRM40CH220J50PT	K22170219	TYP A	6-		
C 4067	CHIP CAP.	22pF	50V	CH	GRM40CH220J50PT	K22170219	TYP B	6-		
C 4067	CHIP CAP.	18pF	50V	CH	GRM40CH180J50PT	K22170217	TYP BS1			
C 4067	CHIP CAP.	18pF	50V	CH	GRM40CH180J50PT	K22170217	TYP C	6-		
C 4068	CHIP CAP.	12pF	50V	CH	GRM40CH120J50PT	K22170213				
C 4069	CHIP CAP.	0.001uF	50V	B	GRM40B102M50PT	K22170805				
C 4070	CHIP CAP.	0.001uF	50V	B	GRM40B102M50PT	K22170805				
C 4071	AL. ELECTRO. CAP.	100uF	25V		25V101M6X11TR5	K46140005				
C 4072	TANTALUM CHIP CAP.	47uF	10V		TEMSVD21A476M12R	K78100019				
C 4073	AL. ELECTRO. CAP.	100uF	25V		25V101M6X11TR5	K46140005				
C 4074	CHIP CAP.	56pF	50V	CH	GRM40CH560J50PT	K22170229				
C 4075	CHIP CAP.	15pF	50V	CH	GRM40CH150J50PT	K22170215				
C 4076	CHIP CAP.	0.1uF	25V	B	GRM40B104M25PT	K22140811				
C 4077	CHIP CAP.	0.047uF	50V	B	GRM40B473M50PT	K22170823				
C 4078	CHIP CAP.	0.001uF	50V	B	GRM40B102M50PT	K22170805				
C 4079	CHIP CAP.	27pF	50V	CH	GRM40CH270J50PT	K22170221				
C 4080	CHIP CAP.	82pF	50V	CH	GRM40CH820J50PT	K22170233				
C 4081	CHIP CAP.	120pF	50V	CH	GRM40CH121J50PT	K22170237				
C 4082	CHIP CAP.	120pF	50V	CH	GRM40CH121J50PT	K22170237	SEP 12.5	5-		
C 4082	CHIP CAP.	82pF	50V	CH	GRM40CH820J50PT	K22170233	SEP 20	5-		
C 4082	CHIP CAP.	82pF	50V	CH	GRM40CH820J50PT	K22170233	SEP 25			
C 4083	AL. ELECTRO. CAP.	100uF	25V		25V101M6X11TR5	K46140005				
C 4084	CHIP CAP.	0.1uF	25V	B	GRM40B104M25PT	K22140811				
C 4085	CHIP CAP.	68pF	50V	CH	GRM40CH680J50PT	K22170231				
C 4086	AL. ELECTRO. CAP.	100uF	25V		25V101M6X11TR5	K46140005				
C 4087	CHIP CAP.	0.047uF	50V	B	GRM40B473M50PT	K22170823				
C 4088	CHIP CAP.	0.047uF	50V	B	GRM40B473M50PT	K22170823				
C 4089	TANTALUM CHIP CAP.	0.33uF	35V		TESVA1V334M1-8R	K78160028				
C 4090	CHIP CAP.	0.01uF	50V	B	GRM40B103M50PT	K22170817				
C 4091	CHIP CAP.	0.001uF	50V	B	GRM40B102M50PT	K22170805				
C 4092	CHIP CAP.	0.047uF	50V	B	GRM40B473M50PT	K22170823				
C 4093	CHIP CAP.	8pF	50V	CH	GRM40CH080D50PT	K22170209	SEP 12.5	5-		

REF.	DESCRIPTION	VALUE	WV	TOL.	MFGR'S DESIG	YAESU P/N	VERS.	LOT.	LAY	ADR
C 4093	CHIP CAP.	15pF	50V	CH	GRM40CH150J50PT	K22170215	SEP 20	5-		
C 4093	CHIP CAP.	15pF	50V	CH	GRM40CH150J50PT	K22170215	SEP 25			
C 4094	CHIP CAP.	0.047uF	50V	B	GRM40B473M50PT	K22170823				
C 4095	CHIP CAP.	0.047uF	50V	B	GRM40B473M50PT	K22170823				
C 4096	CHIP CAP.	22pF	50V	CH	GRM40CH220J50PT	K22170219				
C 4097	CHIP CAP.	18pF	50V	CH	GRM40CH180J50PT	K22170217	SEP 12.5	5-		
C 4097	CHIP CAP.	9pF	50V	CH	GRM40CH090D50PT	K22170210	SEP 20	5-		
C 4097	CHIP CAP.	8pF	50V	CH	GRM40CH080D50PT	K22170209	SEP 25			
C 4098	CHIP CAP.	330pF	50V	CH	GRM40CH331J50PT	K22170247				
C 4099	CHIP CAP.	0.001uF	50V	B	GRM40B102M50PT	K22170805				
C 4100	CHIP CAP.	0.047uF	50V	B	GRM40B473M50PT	K22170823				
C 4101	CHIP CAP.	0.001uF	50V	B	GRM40B102M50PT	K22170805				
C 4102	CHIP CAP.	0.047uF	50V	B	GRM40B473M50PT	K22170823				
C 4103	CHIP CAP.	8pF	50V	CH	GRM40CH080D50PT	K22170209	SEP 12.5	5-		
C 4103	CHIP CAP.	15pF	50V	CH	GRM40CH150J50PT	K22170215	SEP 20	5-		
C 4103	CHIP CAP.	15pF	50V	CH	GRM40CH150J50PT	K22170215	SEP 25			
C 4104	CHIP CAP.	0.01uF	50V	B	GRM40B103M50PT	K22170817				
C 4105	CHIP CAP.	0.001uF	50V	B	GRM40B102M50PT	K22170805				
C 4106	CHIP CAP.	0.0022uF	50V	B	GRM40B222M50PT	K22170809				
C 4107	CHIP CAP.	180pF	50V	CH	GRM40CH181J50PT	K22170241				
C 4108	CHIP CAP.	0.001uF	50V	B	GRM40B102M50PT	K22170805				
C 4109	CHIP CAP.	0.047uF	50V	B	GRM40B473M50PT	K22170823				
C 4110	TANTALUM CHIP CAP.	4.7uF	10V		TESVB21A475M8R	K78100010				
C 4113	CHIP CAP.	0.001uF	50V	B	GRM40B102M50PT	K22170805				
C 4114	TANTALUM CHIP CAP.	4.7uF	10V		TESVB21A475M8R	K78100010				
C 4115	TANTALUM CHIP CAP.	4.7uF	10V		TESVB21A475M8R	K78100010				
C 4116	TANTALUM CHIP CAP.	4.7uF	10V		TESVB21A475M8R	K78100010				
C 4117	CHIP CAP.	0.001uF	50V	B	GRM40B102M50PT	K22170805				
C 4118	CHIP CAP.	0.047uF	50V	B	GRM40B473M50PT	K22170823				
C 4119	CHIP CAP.	0.01uF	50V	B	GRM40B103M50PT	K22170817				
C 4120	TANTALUM CAP.	4.7uF	16V		TPDN1C4R7M8S (MX0)	K76120017				
C 4121	CERAMIC CAP.	0.047uF	50V	F	DD110F473Z50	K13179009				
C 4122	CHIP CAP.	0.001uF	50V	B	GRM40B102M50PT	K22170805				
CD4001	CERAMIC DISC				CDB455C16	H7900740				
CF4001	CERAMIC FILTER				CFW455G	H3900392	SEP 12.5	5-		
CF4001	CERAMIC FILTER				CFW455F	H3900202	SEP 20	5-		
CF4001	CERAMIC FILTER				CFW455E	H3900200	SEP 25			
D 4001	DIODE				1SS226 TE85R	G2070003				
D 4002	DIODE				HSU277	G2070118				
D 4003	DOUBLE-BALANCED-MIXER				DBM0135	Q7000183				
D 4004	DIODE				1SS226 TE85R	G2070003				
D 4005	DIODE				1SS226 TE85R	G2070003				
J 4001	CONNECTOR				SC25-10WL	P0090717				
J 4002	CONNECTOR				SC25-02WL	P0090712				
J 4003	CONNECTOR				TMP-J01X-V6	P1090210				
J 4004	CONNECTOR				BNC-RM-1 (W/O LUG)	P1090773A				
L 4001	CHIP COIL	10uH			LQH3N100K02M00-	L1690087				
L 4002	COIL				S7-M1 R12-M944D	L0190205				
L 4003	COIL				S7-M1 R12-M944D	L0190205				

REF.	DESCRIPTION	VALUE	WV	TOL.	MFGR'S DESIG	YAESU P/N	VER.S.	LOT.	LAY	ADR
L 4004	M. RFC	1uH			FLC32T-1R0K	L1690203				
L 4005	COIL				S7-M1 R12-M944D	L0190205				
L 4006	M RFC	1uH			FLC32T-1R0K	L1690203				
L 4007	CHIP COIL	10uH			LQH3N100K02M00-	L1690087				
L 4008	CHIP COIL	0.082uH			LQN2A82NM	L1690010				
L 4009	CHIP COIL	0.01uH			LQN2A10NM	L1690001				
L 4010	M. RFC	1uH			FLC32T-1R0K	L1690203				
L 4011	COIL				S7-M1 R12-M944D	L0190205				
L 4012	CHIP COIL	0.082uH			LQN2A82NM	L1690010				
L 4013	COIL				S7-M1 R12-M944D	L0190205				
L 4014	CHIP COIL	0.056uH			LQN2A56NM	L1690008				
L 4015	COIL				S7-M1 R12-M944D	L0190205				
L 4016	CHIP COIL	0.082uH			LQN2A82NM	L1690010				
L 4017	CHIP COIL	0.18uH			LQN2AR18K	L1690014				
L 4018	M. RFC	1uH			FLC32T-1R0K	L1690203				
L 4019	M. RFC	1uH			FLC32T-1R0K	L1690203				
L 4020	M. RFC	1uH			FLC32T-1R0K	L1690203				
L 4021	CHIP COIL	0.056uH			LQN2A56NM	L1690008				
L 4022	M. RFC	1uH			FLC32T-1R0K	L1690203				
L 4023	M. RFC	1uH			FLC32T-1R0K	L1690203				
L 4024	CHIP COIL	0.18uH			LQN2AR18K	L1690014				
L 4025	M. RFC	1uH			FLC32T-1R0K	L1690203				
Q 4001	IC				TA78L05F TE12R	G1091014				
Q 4002	IC				AN6541	G1091146				
Q 4003	TRANSISTOR				DTA143EK T146	G3070010				
Q 4004	TRANSISTOR				2SA1179M5-TA	G3111797E				
Q 4005	TRANSISTOR				2SA1179M5-TA	G3111797E				
Q 4006	TRANSISTOR				DTC115GK T146	G3070092				
Q 4007	TRANSISTOR				2SA1179M5-TA	G3111797E				
Q 4008	TRANSISTOR				DTC144EK T147	G3070033				
Q 4009	TRANSISTOR				DTA143EK T146	G3070010				
Q 4010	FET				3SK131-T2B V12	G4801317B				
Q 4011	TRANSISTOR				2SC3357-T2 RF	G3333577F				
Q 4012	TRANSISTOR				2SC3356-T2B R24	G3333567D				
Q 4014	IC				MC145190FER	G1091621				
Q 4015	TRANSISTOR				2SC3356-T2B R24	G3333567D				
Q 4016	IC				NJM2902M-T2	G1090908				
Q 4017	IC				MC3372ML	G1091108				
Q 4018	TRANSISTOR				2SC3356-T2B R24	G3333567D				
Q 4019	TRANSISTOR				DTC144EK T147	G3070033	SEP 20			5-
Q 4019	TRANSISTOR				DTC144EK T147	G3070033	SEP 25			
Q 4020	TRANSISTOR				2SC2812L6-TA	G3328127F				
Q 4021	TRANSISTOR				2SA1179M6-TA	G3111797F	SEP 20			5-
Q 4021	TRANSISTOR				2SA1179M6-TA	G3111797F	SEP 25			
Q 4022	TRANSISTOR				DTC144EK T147	G3070033				
Q 4023	TRANSISTOR				2SC2812L6-TA	G3328127F				
Q 4024	TRANSISTOR				2SC3356-T2B R24	G3333567D				
Q 4025	TRANSISTOR				2SC2812L6-TA	G3328127F				
Q 4026	TRANSISTOR				2SC2812L6-TA	G3328127F				
Q 4027	TRANSISTOR				DTC144EK T147	G3070033				
R 4002	CHIP RES.	0	1/10W	5%	RMC1/10T 000J	J24205000	SEP 12.5			5-
R 4002	CHIP RES.	0	1/10W	5%	RMC1/10T 000J	J24205000	SEP 20			5-

REF.	DESCRIPTION	VALUE	WV	TOL.	MFGR'S DESIG	YAESU P/N	VERS.	LOT.	LAY	ADR
R 4002	CHIP RES.	0	1/10W	5%	RMC1/10T 000J	J24205000	SEP 25			
R 4004	CHIP RES.	4.7K	1/10W	5%	RMC1/10T 472J	J24205472				
R 4005	CHIP RES.	1.8K	1/10W	5%	RMC1/10T 182J	J24205182				
R 4006	CHIP RES.	47K	1/10W	5%	RMC1/10T 473J	J24205473				
R 4007	CHIP RES.	47K	1/10W	5%	RMC1/10T 473J	J24205473				
R 4008	CHIP RES.	47K	1/10W	5%	RMC1/10T 473J	J24205473				
R 4009	CHIP RES.	560	1/10W	5%	RMC1/10T 561J	J24205561				
R 4010	CHIP RES.	4.7K	1/10W	5%	RMC1/10T 472J	J24205472				
R 4011	CHIP RES.	4.7K	1/10W	5%	RMC1/10T 472J	J24205472				
R 4012	CHIP RES.	1.5K	1/10W	5%	RMC1/10T 152J	J24205152				
R 4013	CHIP RES.	12K	1/10W	5%	RMC1/10T 123J	J24205123				
R 4014	CHIP RES.	100	1/10W	5%	RMC1/10T 101J	J24205101				
R 4015	CHIP RES.	3.3K	1/10W	5%	RMC1/10T 332J	J24205332				
R 4016	CHIP RES.	47	1/10W	5%	RMC1/10T 470J	J24205470				
R 4017	CHIP RES.	270	1/10W	5%	RMC1/10T 271J	J24205271				
R 4018	CHIP RES.	4.7K	1/10W	5%	RMC1/10T 472J	J24205472				
R 4019	CHIP RES.	18	1/10W	5%	RMC1/10T 180J	J24205180				
R 4020	CHIP RES.	560	1/10W	5%	RMC1/10T 561J	J24205561				
R 4021	CHIP RES.	470	1/10W	5%	RMC1/10T 471J	J24205471				
R 4022	CHIP RES.	2.2K	1/10W	5%	RMC1/10T 222J	J24205222				
R 4023	CHIP RES.	1.5K	1/10W	5%	RMC1/10T 152J	J24205152				
R 4024	CHIP RES.	270	1/10W	5%	RMC1/10T 271J	J24205271				
R 4025	CHIP RES.	150	1/10W	5%	RMC1/10T 151J	J24205151				
R 4026	CHIP RES.	220	1/10W	5%	RMC1/10T 221J	J24205221				
R 4027	CHIP RES.	56	1/10W	5%	RMC1/10T 560J	J24205560				
R 4028	CHIP RES.	8.2K	1/10W	5%	RMC1/10T 822J	J24205822				
R 4029	CHIP RES.	1K	1/10W	5%	RMC1/10T 102J	J24205102				
R 4030	CHIP RES.	560	1/10W	5%	RMC1/10T 561J	J24205561				
R 4031	CHIP RES.	3.3K	1/10W	5%	RMC1/10T 332J	J24205332				
R 4032	CHIP RES.	8.2K	1/10W	5%	RMC1/10T 822J	J24205822				
R 4033	CHIP RES.	18	1/10W	5%	RMC1/10T 180J	J24205180				
R 4035	CHIP RES.	47	1/10W	5%	RMC1/10T 470J	J24205470				
R 4036	CHIP RES.	560	1/10W	5%	RMC1/10T 561J	J24205561				
R 4037	CHIP RES.	4.7K	1/10W	5%	RMC1/10T 472J	J24205472				
R 4038	CHIP RES.	18	1/10W	5%	RMC1/10T 180J	J24205180				
R 4041	CHIP RES.	18	1/10W	5%	RMC1/10T 180J	J24205180				
R 4042	CHIP RES.	47K	1/10W	5%	RMC1/10T 473J	J24205473				
R 4044	CHIP RES.	220K	1/10W	5%	RMC1/10T 224J	J24205224				
R 4045	CHIP RES.	10K	1/10W	5%	RMC1/10T 103J	J24205103				
R 4047	CHIP RES.	220	1/10W	5%	RMC1/10T 221J	J24205221				
R 4048	CHIP RES.	10K	1/10W	5%	RMC1/10T 103J	J24205103				
R 4049	CHIP RES.	270	1/10W	5%	RMC1/10T 271J	J24205271				
R 4050	CHIP RES.	270	1/10W	5%	RMC1/10T 271J	J24205271				
R 4051	CHIP RES.	18	1/10W	5%	RMC1/10T 180J	J24205180				
R 4052	CHIP RES.	270	1/10W	5%	RMC1/10T 271J	J24205271				
R 4053	CHIP RES.	18	1/10W	5%	RMC1/10T 180J	J24205180				
R 4054	CHIP RES.	270	1/10W	5%	RMC1/10T 271J	J24205271				
R 4055	CHIP RES.	560	1/10W	5%	RMC1/10T 561J	J24205561				
R 4056	CHIP RES.	47	1/10W	5%	RMC1/10T 470J	J24205470				
R 4057	CHIP RES.	2.2K	1/10W	5%	RMC1/10T 222J	J24205222	SEP 12.5	5-		
R 4057	CHIP RES.	1.5K	1/10W	5%	RMC1/10T 152J	J24205152	SEP 20	5-		
R 4057	CHIP RES.	1.2K	1/10W	5%	RMC1/10T 122J	J24205122	SEP 25			
R 4058	CHIP RES.	4.7K	1/10W	5%	RMC1/10T 472J	J24205472				
R 4059	CHIP RES.	4.7K	1/10W	5%	RMC1/10T 472J	J24205472				

REF.	DESCRIPTION	VALUE	WV	TOL.	MFGR'S DESIG	YAESU P/N	VERS.	LOT.	LAY	ADR
R 4060	CHIP RES.	4.7K	1/10W	5%	RMC1/10T 472J	J24205472				
R 4061	CHIP RES.	47	1/10W	5%	RMC1/10T 470J	J24205470				
R 4062	CHIP RES.	470K	1/10W	5%	RMC1/10T 474J	J24205474				
R 4063	CHIP RES.	4.7K	1/10W	5%	RMC1/10T 472J	J24205472				
R 4064	CHIP RES.	47K	1/10W	5%	RMC1/10T 473J	J24205473				
R 4065	CHIP RES.	100	1/10W	5%	RMC1/10T 101J	J24205101				
R 4066	CHIP RES.	100K	1/10W	5%	RMC1/10T 104J	J24205104				
R 4067	CHIP RES.	1.8K	1/10W	5%	RMC1/10T 182J	J24205182				
R 4068	CHIP RES.	1.8K	1/10W	5%	RMC1/10T 182J	J24205182				
R 4069	CHIP RES.	220K	1/10W	5%	RMC1/10T 224J	J24205224				
R 4070	CHIP RES.	3.3K	1/10W	5%	RMC1/10T 332J	J24205332				
R 4071	CHIP RES.	47	1/10W	5%	RMC1/10T 470J	J24205470	SEP 12.5		5-	
R 4071	CHIP RES.	15	1/10W	5%	RMC1/10T 150J	J24205150	SEP 20		5-	
R 4071	CHIP RES.	15	1/10W	5%	RMC1/10T 150J	J24205150	SEP 25			
R 4072	CHIP RES.	56K	1/10W	5%	RMC1/10T 563J	J24205563				
R 4073	CHIP RES.	100	1/10W	5%	RMC1/10T 101J	J24205101				
R 4074	CHIP RES.	10	1/10W	5%	RMC1/10T 100J	J24205100				
R 4075	CHIP RES.	560	1/10W	5%	RMC1/10T 561J	J24205561	SEP 12.5		5-	
R 4075	CHIP RES.	560	1/10W	5%	RMC1/10T 561J	J24205561	SEP 20		5-	
R 4075	CHIP RES.	470	1/10W	5%	RMC1/10T 471J	J24205471	SEP 25			
R 4076	CHIP RES.	47K	1/10W	5%	RMC1/10T 473J	J24205473				
R 4077	CHIP RES.	10K	1/10W	5%	RMC1/10T 103J	J24205103	SEP 20		5-	
R 4077	CHIP RES.	10K	1/10W	5%	RMC1/10T 103J	J24205103	SEP 25			
R 4078	CHIP RES.	100K	1/10W	5%	RMC1/10T 104J	J24205104	SEP 20		5-	
R 4078	CHIP RES.	100K	1/10W	5%	RMC1/10T 104J	J24205104	SEP 25			
R 4079	CHIP RES.	560	1/10W	5%	RMC1/10T 561J	J24205561				
R 4080	CHIP RES.	2.2K	1/10W	5%	RMC1/10T 222J	J24205222				
R 4081	CHIP RES.	47K	1/10W	5%	RMC1/10T 473J	J24205473				
R 4083	CHIP RES.	680	1/10W	5%	RMC1/10T 681J	J24205681	SEP 12.5		5-	
R 4083	CHIP RES.	560	1/10W	5%	RMC1/10T 561J	J24205561	SEP 20		5-	
R 4083	CHIP RES.	560	1/10W	5%	RMC1/10T 561J	J24205561	SEP 25			
R 4084	CHIP RES.	10K	1/10W	5%	RMC1/10T 103J	J24205103	SEP 20		5-	
R 4084	CHIP RES.	10K	1/10W	5%	RMC1/10T 103J	J24205103	SEP 25			
R 4085	CHIP RES.	47K	1/10W	5%	RMC1/10T 473J	J24205473				
R 4087	CHIP RES.	560	1/10W	5%	RMC1/10T 561J	J24205561				
R 4088	CHIP RES.	82K	1/10W	5%	RMC1/10T 823J	J24205823				
R 4089	CHIP RES.	2.2K	1/10W	5%	RMC1/10T 222J	J24205222				
R 4090	CHIP RES.	4.7K	1/10W	5%	RMC1/10T 472J	J24205472				
R 4091	CHIP RES.	2.2K	1/10W	5%	RMC1/10T 222J	J24205222				
R 4092	CHIP RES.	33	1/10W	5%	RMC1/10T 330J	J24205330				
R 4093	CHIP RES.	2.2K	1/10W	5%	RMC1/10T 222J	J24205222				
R 4094	CHIP RES.	2.7K	1/10W	5%	RMC1/10T 272J	J24205272				
R 4095	CHIP RES.	3.9K	1/10W	5%	RMC1/10T 392J	J24205392				
R 4096	CHIP RES.	470	1/10W	5%	RMC1/10T 471J	J24205471				
R 4097	CHIP RES.	1K	1/10W	5%	RMC1/10T 102J	J24205102				
R 4098	CHIP RES.	3.9K	1/10W	5%	RMC1/10T 392J	J24205392				
R 4099	CHIP RES.	1.8K	1/10W	5%	RMC1/10T 182J	J24205182				
R 4100	CHIP RES.	3.3K	1/10W	5%	RMC1/10T 332J	J24205332				
R 4101	CHIP RES.	470	1/10W	5%	RMC1/10T 471J	J24205471				
R 4102	CHIP RES.	820	1/10W	5%	RMC1/10T 821J	J24205821				
R 4103	CHIP RES.	3.3K	1/10W	5%	RMC1/10T 332J	J24205332	SEP 12.5		5-	
R 4103	CHIP RES.	6.8K	1/10W	5%	RMC1/10T 682J	J24205682	SEP 20		5-	
R 4103	CHIP RES.	6.8K	1/10W	5%	RMC1/10T 682J	J24205682	SEP 25			
R 4104	CHIP RES.	1.5K	1/10W	5%	RMC1/10T 152J	J24205152	SEP 12.5		5-	

REF.	DESCRIPTION	VALUE	WV	TOL.	MFGR'S DESIG	YAESU P/N	VERS.	LOT.	LAY	ADR
R 4104	CHIP RES.	1.5K	1/10W	5%	RMC1/10T 152J	J24205152	SEP 20	5-		
R 4104	CHIP RES.	1.2K	1/10W	5%	RMC1/10T 122J	J24205122	SEP 25			
R 4105	CHIP RES.	2.2K	1/10W	5%	RMC1/10T 222J	J24205222				
R 4106	CHIP RES.	18K	1/10W	5%	RMC1/10T 183J	J24205183				
R 4107	CHIP RES.	0	1/10W	5%	RMC1/10T 000J	J24205000	SEP 20	5-		
R 4107	CHIP RES.	0	1/10W	5%	RMC1/10T 000J	J24205000	SEP 25			
R 4108	CHIP RES.	0	1/10W	5%	RMC1/10T 000J	J24205000	SEP 12.5	5-		
R 4109	CHIP RES.	0	1/10W	5%	RMC1/10T 000J	J24205000	SEP 20	5-		
R 4109	CHIP RES.	0	1/10W	5%	RMC1/10T 000J	J24205000	SEP 25			
R 4110	CHIP RES.	0	1/10W	5%	RMC1/10T 000J	J24205000	SEP 12.5	5-		
R 4111	CHIP RES.	33K	1/10W	5%	RMC1/10T 333J	J24205333				
R 4112	CHIP RES.	2.7K	1/10W	5%	RMC1/10T 272J	J24205272				
R 4113	CHIP RES.	470	1/10W	5%	RMC1/10T 471J	J24205471				
R 4114	CHIP RES.	100K	1/10W	5%	RMC1/10T 104J	J24205104				
R 4115	CHIP RES.	0	1/10W	5%	RMC1/10T 000J	J24205000				
R 4117	CHIP RES.	68K	1/10W	5%	RMC1/10T 683J	J24205683				
R 4118	CHIP RES.	3.3K	1/10W	5%	RMC1/10T 332J	J24205332				
R 4120	CHIP RES.	10	1/10W	5%	RMC1/10T 100J	J24205100				
R 4121	CHIP RES.	390	1/10W	5%	RMC1/10T 391J	J24205391	SEP 12.5	5-		
R 4122	CHIP RES.	0	1/10W	5%	RMC1/10T 000J	J24205000	SEP 12.5	5-		
T 4001	COIL				21.4M R12-L925A	L0022174	SEP 12.5	5-		
T 4001	COIL				21.4M R12-M943A	L0022219	SEP 20	5-		
T 4001	COIL				21.4M R12-M943A	L0022219	SEP 25			
T 4002	COIL				21.4M R12-L925A	L0022174	SEP 12.5	5-		
T 4002	COIL				21.4M R12-M943A	L0022219	SEP 20	5-		
T 4002	COIL				21.4M R12-M943A	L0022219	SEP 25			
TH4002	THERMISTOR				157-501-53009TP	G9090058	SEP 20	5-		
TH4002	THERMISTOR				157-501-53009TP	G9090058	SEP 25			
TH4003	THERMISTOR				157-501-53009TP	G9090058	SEP 12.5	5-		
VR4001	POT.	2K			EVN-DCAA03B23	J50784202				
X 4002	XTAL				GFS-720(60206)	H9500210				
X 4003	XTAL	22.055MHz			UM-1	H0102774				
XF4001	XTAL				21P8SBU-1	H1102138	SEP 12.5	5-		
XF4001	XTAL				21P12BU-1	H1102132	SEP 20	5-		
XF4001	XTAL				21P15BU-1	H1102137	SEP 25			
	LEAF SPRING					R0121430				
	SHIELD FRAME					R0147200				
	SHIELD COVER					R0147210				
	SHIELD CASE					R0519070A				
	XTAL HOLDER (3pcs)					R3129530				
	SPECIAL NUT (4pcs)					R6068570				
	STICK FINGER (2pcs)				97-505-01 2BLOCK	S5000159				

Parts Layout

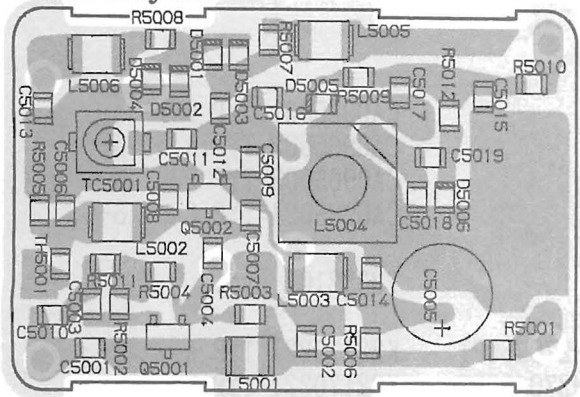

obverse view of component side

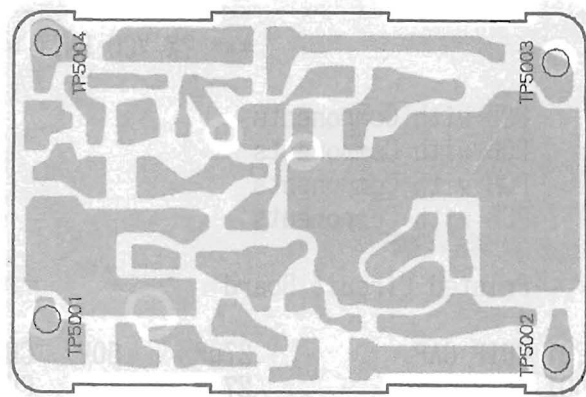

obverse view of solder side

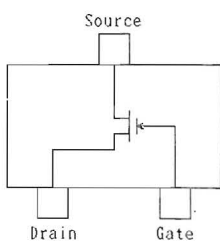

2SK302GR (TG)
(Q5002)

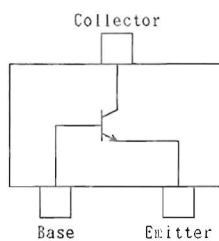

2SC3356 (R24)
(Q5001)

Circuit Diagram

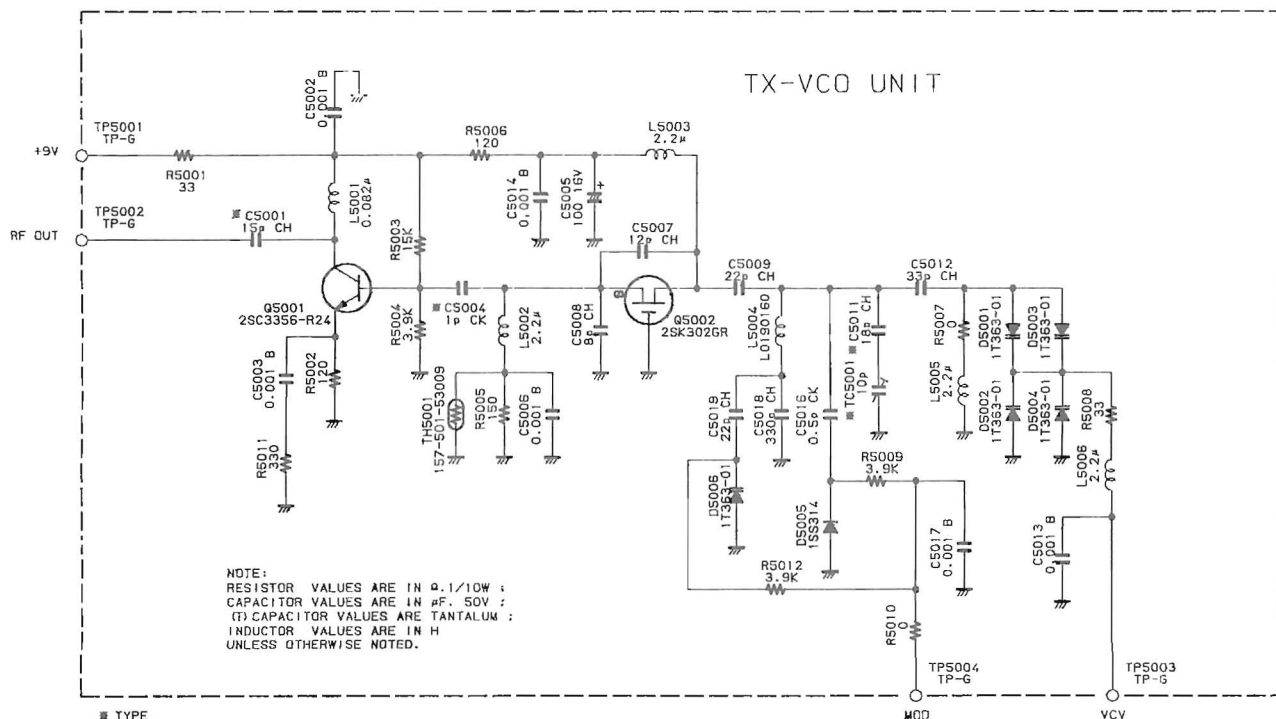

※ TYPE

	A	B	BS1	C
C5001	27P	27P	15P	15P
C5004	2P	1P	1P	1P
C5011	47P	27P	18P	18P
TC5001	20P	20P	10P	10P

REF.	DESCRIPTION	VALUE	WV	TOL.	MFGR'S DESIG	YAESU P/N	VERS.	LOT.	LAY ADR
*** TX VCO UNIT ***									
	PCB with Components					CA0965001	TYP BS1		
	PCB with Components					CA0965002	TYP A	6-	
	PCB with Components					CA0965003	TYP B	6-	
	PCB with Components					CA0965004	TYP C	6-	
	Printed Circuit Board					F3382101			
C 5001	CHIP CAP.	27pF	50V	CH	GRM40CH270J50PT	K22170221	TYP A	6-	
C 5001	CHIP CAP.	27pF	50V	CH	GRM40CH270J50PT	K22170221	TYP B	6-	
C 5001	CHIP CAP.	15pF	50V	CH	GRM40CH150J50PT	K22170215	TYP BS1		
C 5001	CHIP CAP.	15pF	50V	CH	GRM40CH150J50PT	K22170215	TYP C	6-	
C 5002	CHIP CAP.	0.001uF	50V	B	GRM40B102M50PT	K22170805			
C 5003	CHIP CAP.	0.001uF	50V	B	GRM40B102M50PT	K22170805			
C 5004	CHIP CAP.	2pF	50V	CK	GRM40CK020C50PT	K22170203	TYP A	6-	
C 5004	CHIP CAP.	1pF	50V	CK	GRM40CK010C50PT	K22170202	TYP B	6-	
C 5004	CHIP CAP.	1pF	50V	CK	GRM40CK010C50PT	K22170202	TYP BS1		
C 5004	CHIP CAP.	1pF	50V	CK	GRM40CK010C50PT	K22170202	TYP C	6-	
C 5005	AL. ELECTRO. CAP.	100uF	16V		RC2-16V101MS(6X7)	K40129038			
C 5006	CHIP CAP.	0.001uF	50V	B	GRM40B102M50PT	K22170805			
C 5007	CHIP CAP.	12pF	50V	CH	GRM40CH120J50PT	K22170213			
C 5008	CHIP CAP.	8pF	50V	CH	GRM40CH080D50PT	K22170209			
C 5009	CHIP CAP.	22pF	50V	CH	GRM40CH220J50PT	K22170219			
C 5011	CHIP CAP.	47pF	50V	CH	GRM40CH470J50PT	K22170227	TYP A	6-	
C 5011	CHIP CAP.	27pF	50V	CH	GRM40CH270J50PT	K22170221	TYP B	6-	
C 5011	CHIP CAP.	18pF	50V	CH	GRM40CH180J50PT	K22170217	TYP BS1		
C 5011	CHIP CAP.	18pF	50V	CH	GRM40CH180J50PT	K22170217	TYP C	6-	
C 5012	CHIP CAP.	33pF	50V	CH	GRM40CH330J50PT	K22170223			
C 5013	CHIP CAP.	0.001uF	50V	B	GRM40B102M50PT	K22170805			
C 5014	CHIP CAP.	0.001uF	50V	B	GRM40B102M50PT	K22170805			
C 5016	CHIP CAP.	0.5pF	50V	CK	GRM40CK0R5C50PT	K22170201			
C 5017	CHIP CAP.	0.001uF	50V	B	GRM40B102M50PT	K22170805			
C 5018	CHIP CAP.	330pF	50V	CH	GRM40CH331J50PT	K22170247			
C 5019	CHIP CAP.	22pF	50V	CH	GRM40CH220J50PT	K22170219			
D 5001	DIODE				1T363-01-T08A	G2070114			
D 5002	DIODE				1T363-01-T08A	G2070114			
D 5003	DIODE				1T363-01-T08A	G2070114			
D 5004	DIODE				1T363-01-T08A	G2070114			
D 5005	DIODE				1SS314 TPH3	G2070122			
D 5006	DIODE				1T363-01-T08A	G2070114			
L 5001	CHIP COIL	0.082uH			LQN2A82NM	L1690010			
L 5002	M. RFC	2.2uH			FLC32T-2R2K	L1690207			
L 5003	M. RFC	2.2uH			FLC32T-2R2K	L1690207			
L 5004	COIL				MC131	L0190160			
L 5005	M. RFC	2.2uH			FLC32T-2R2K	L1690207			
L 5006	M. RFC	2.2uH			FLC32T-2R2K	L1690207			
Q 5001	TRANSISTOR				2SC3356-T2B R24	G3333567D			
Q 5002	FET				2SK302GR TE85R	G3803027G			
R 5001	CHIP RES.	33	1/10W	5%	RMC1/10T 330J	J24205330			

REF.	DESCRIPTION	VALUE	WV	TOL.	MFGR'S DESIG	YAESU P/N	VERS.	LOT.	LAY	ADR
R 5002	CHIP RES.	120	1/10W	5%	RMC1/10T 121J	J24205121				
R 5003	CHIP RES.	15K	1/10W	5%	RMC1/10T 153J	J24205153				
R 5004	CHIP RES.	3.9K	1/10W	5%	RMC1/10T 392J	J24205392				
R 5005	CHIP RES.	150	1/10W	5%	RMC1/10T 151J	J24205151				
R 5006	CHIP RES.	120	1/10W	5%	RMC1/10T 121J	J24205121				
R 5007	CHIP RES.	0	1/10W	5%	RMC1/10T 000J	J24205000				
R 5008	CHIP RES.	33	1/10W	5%	RMC1/10T 330J	J24205330				
R 5009	CHIP RES.	3.9K	1/10W	5%	RMC1/10T 392J	J24205392				
R 5010	CHIP RES.	0	1/10W	5%	RMC1/10T 000J	J24205000				
R 5011	CHIP RES.	330	1/10W	5%	RMC1/10T 331J	J24205331				
R 5012	CHIP RES.	3.9K	1/10W	5%	RMC1/10T 392J	J24205392				
TC5001	CHIP TRIMMER	20pF			TZBX4R200BA110T00	K91000190	TYP A		6-	
TC5001	CHIP TRIMMER	20pF			TZBX4R200BA110T00	K91000190	TYP B		6-	
TC5001	TRIMMER CAP.	10pF			TZBX4N100BA110T00	K91000192	TYP BS1			
TC5001	TRIMMER CAP.	10pF			TZBX4N100BA110T00	K91000192	TYP C		6-	
TH5001	THERMISTOR				157-501-53009TP	G9090058				
TP5001	TP-G				MK1095	Q5000036				
TP5002	TP-G				MK1095	Q5000036				
TP5003	TP-G				MK1095	Q5000036				
TP5004	TP-G				MK1095	Q5000036				
	SHIELD CASE					R0146370				

Notes:

REF.	DESCRIPTION	VALUE	WV	TOL.	MFGR'S DESIG	YAESU P/N	VERS.	LOT.	LAY	ADR
*** RX VCO UNIT ***										
	PCB with Components					CA0966001	TYP BS1			
	PCB with Components					CA0966002	TYP A	6-		
	PCB with Components					CA0966003	TYP B	6-		
	PCB with Components					CA0966004	TYP C	6-		
	Printed Circuit Board					F3382102				
C 5501	CHIP CAP.	18pF	50V	CH	GRM40CH180J50PT	K22170217	TYP A	6-		
C 5501	CHIP CAP.	15pF	50V	CH	GRM40CH150J50PT	K22170215	TYP B	6-		
C 5501	CHIP CAP.	15pF	50V	CH	GRM40CH150J50PT	K22170215	TYP BS1			
C 5501	CHIP CAP.	10pF	50V	CH	GRM40CH100D50PT	K22170211	TYP C	6-		
C 5502	CHIP CAP.	0.001uF	50V	B	GRM40B102M50PT	K22170805				
C 5503	CHIP CAP.	0.001uF	50V	B	GRM40B102M50PT	K22170805				
C 5504	CHIP CAP.	1pF	50V	CK	GRM40CK010C50PT	K22170202	TYP A	6-		
C 5504	CHIP CAP.	1pF	50V	CK	GRM40CK010C50PT	K22170202	TYP B	6-		
C 5504	CHIP CAP.	2pF	50V	CK	GRM40CK020C50PT	K22170203	TYP BS1			
C 5504	CHIP CAP.	2pF	50V	CK	GRM40CK020C50PT	K22170203	TYP C	6-		
C 5505	AL. ELECTRO. CAP.	100uF	16V		RC2-16V101MS (6X7)	K40129038				
C 5506	CHIP CAP.	0.001uF	50V	B	GRM40B102M50PT	K22170805				
C 5507	CHIP CAP.	8pF	50V	CH	GRM40CH080D50PT	K22170209	TYP A	6-		
C 5507	CHIP CAP.	8pF	50V	CH	GRM40CH080D50PT	K22170209	TYP B	6-		
C 5507	CHIP CAP.	8pF	50V	CH	GRM40CH080D50PT	K22170209	TYP BS1			
C 5507	CHIP CAP.	7pF	50V	CH	GRM40CH070D50PT	K22170208	TYP C	6-		
C 5508	CHIP CAP.	12pF	50V	CH	GRM40CH120J50PT	K22170213	TYP A	6-		
C 5508	CHIP CAP.	12pF	50V	CH	GRM40CH120J50PT	K22170213	TYP B	6-		
C 5508	CHIP CAP.	12pF	50V	CH	GRM40CH120J50PT	K22170213	TYP BS1			
C 5508	CHIP CAP.	10pF	50V	CH	GRM40CH100D50PT	K22170211	TYP C	6-		
C 5509	CHIP CAP.	12pF	50V	CH	GRM40CH120J50PT	K22170213	TYP A	6-		
C 5509	CHIP CAP.	12pF	50V	CH	GRM40CH120J50PT	K22170213	TYP B	6-		
C 5509	CHIP CAP.	10pF	50V	CH	GRM40CH100D50PT	K22170211	TYP BS1			
C 5509	CHIP CAP.	9pF	50V	CH	GRM40CH090D50PT	K22170210	TYP C	6-		
C 5511	CHIP CAP.	22pF	50V	CH	GRM40CH220J50PT	K22170219	TYP A	6-		
C 5511	CHIP CAP.	10pF	50V	CH	GRM40CH100D50PT	K22170211	TYP B	6-		
C 5511	CHIP CAP.	10pF	50V	CH	GRM40CH100D50PT	K22170211	TYP BS1			
C 5511	CHIP CAP.	7pF	50V	CH	GRM40CH070D50PT	K22170208	TYP C	6-		
C 5512	CHIP CAP.	39pF	50V	CH	GRM40CH390J50PT	K22170225	TYP A	6-		
C 5512	CHIP CAP.	39pF	50V	CH	GRM40CH390J50PT	K22170225	TYP B	6-		
C 5512	CHIP CAP.	27pF	50V	CH	GRM40CH270J50PT	K22170221	TYP BS1			
C 5512	CHIP CAP.	22pF	50V	CH	GRM40CH220J50PT	K22170219	TYP C	6-		
C 5513	CHIP CAP.	0.001uF	50V	B	GRM40B102M50PT	K22170805				
C 5514	CHIP CAP.	0.001uF	50V	B	GRM40B102M50PT	K22170805				
D 5501	DIODE				1T363-01-T08A	G2070114				
D 5502	DIODE				1T363-01-T08A	G2070114				
D 5503	DIODE				1T363-01-T08A	G2070114				
D 5504	DIODE				1T363-01-T08A	G2070114				
L 5501	CHIP COIL	0.1uH			LQN2AR10K	L1690011	TYP A	6-		
L 5501	CHIP COIL	0.082uH			LQN2A82NM	L1690010	TYP B	6-		
L 5501	CHIP COIL	0.082uH			LQN2A82NM	L1690010	TYP BS1			
L 5501	CHIP COIL	0.082uH			LQN2A82NM	L1690010	TYP C	6-		
L 5502	M. RFC	2.2uH			FLC32T-2R2K	L1690207				

REF.	DESCRIPTION	VALUE	WV	TOL.	MFGR'S DESIG	YAESU P/N	VERS.	LOT.	LAY	ADR
L 5503	CHIP COIL	10uH			LQH3N100K02M00-	L1690087				
L 5504	COIL				MC131	L0190147				
L 5505	CHIP COIL	10uH			LQH3N100K02M00-	L1690087				
L 5506	M. RFC	2.2uH			FLC32T-2R2K	L1690207				
Q 5501	TRANSISTOR				2SC3356-T2B R24	G3333567D				
Q 5502	FET				2SK302GR TE85R	G3803027G				
R 5501	CHIP RES.	33	1/10W	5%	RMC1/10T 330J	J24205330				
R 5502	CHIP RES.	120	1/10W	5%	RMC1/10T 121J	J24205121				
R 5503	CHIP RES.	15K	1/10W	5%	RMC1/10T 153J	J24205153				
R 5504	CHIP RES.	3.9K	1/10W	5%	RMC1/10T 392J	J24205392				
R 5505	CHIP RES.	120	1/10W	5%	RMC1/10T 121J	J24205121				
R 5506	CHIP RES.	680	1/10W	5%	RMC1/10T 681J	J24205681				
R 5507	CHIP RES.	0	1/10W	5%	RMC1/10T 000J	J24205000				
R 5508	CHIP RES.	33	1/10W	5%	RMC1/10T 330J	J24205330				
R 5511	CHIP RES.	330	1/10W	5%	RMC1/10T 331J	J24205331				
TC5501	CHIP TRIMMER	20pF			TZBX4R200BA110T00	K91000190	TYP A	6-		
TC5501	CHIP TRIMMER	20pF			TZBX4R200BA110T00	K91000190	TYP B	6-		
TC5501	TRIMMER CAP.	10pF			TZBX4N100BA110T00	K91000192	TYP BS1			
TC5501	TRIMMER CAP.	10pF			TZBX4N100BA110T00	K91000192	TYP C	6-		
TP5501	TP-G				MK1095	Q5000036				
TP5502	TP-G				MK1095	Q5000036				
TP5503	TP-G				MK1095	Q5000036				
	SHIELD CASE					R0146370				

Notes:

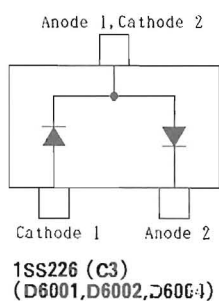
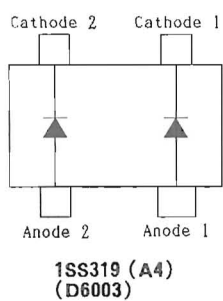
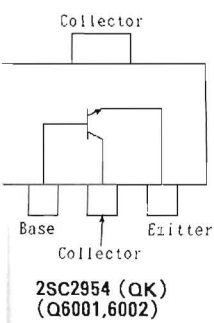
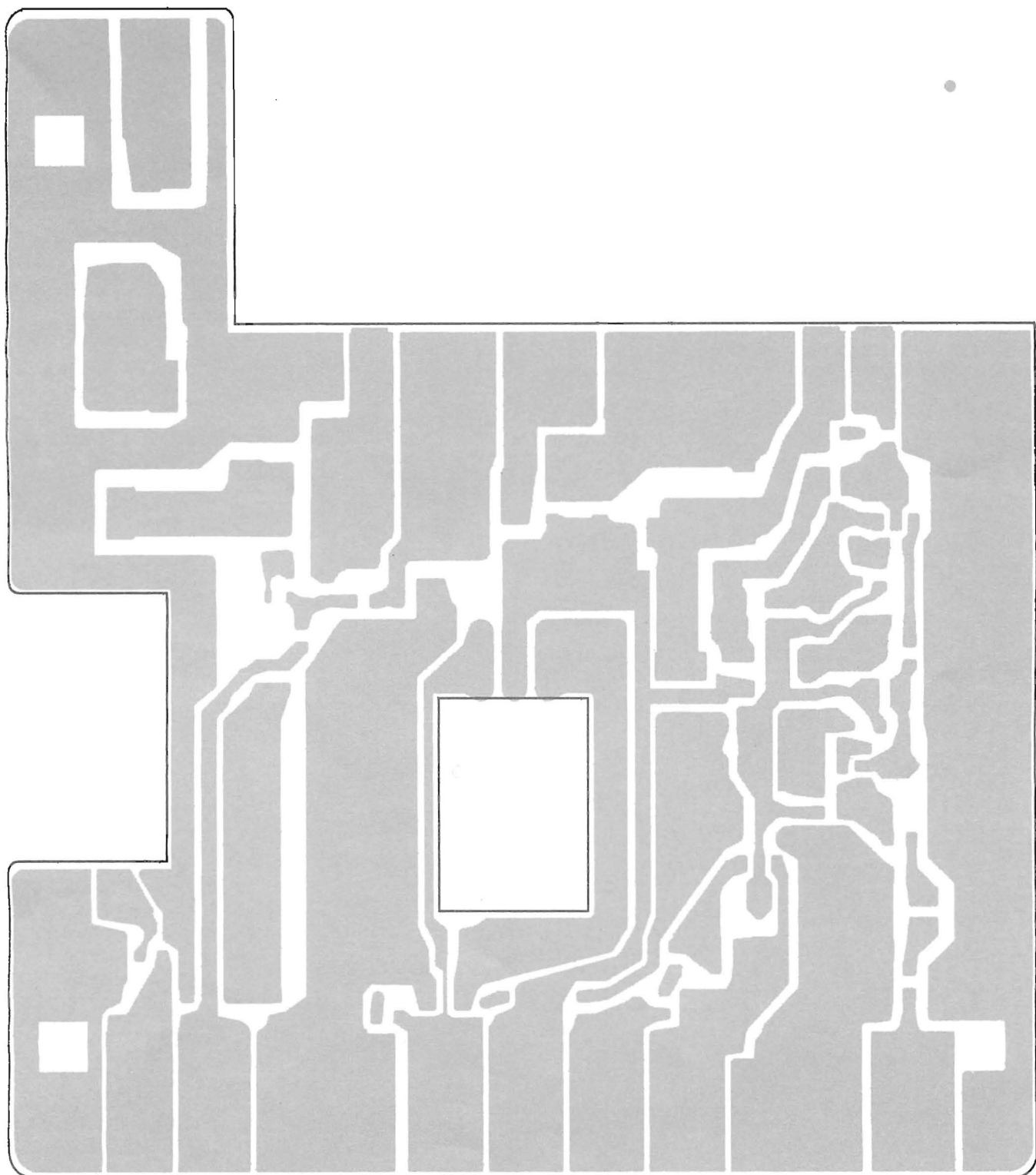

obverse view of solder side

Parts Layout

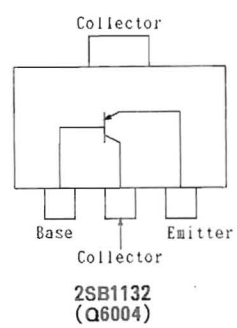
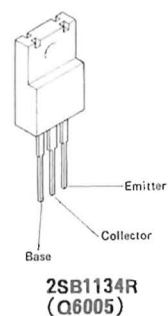
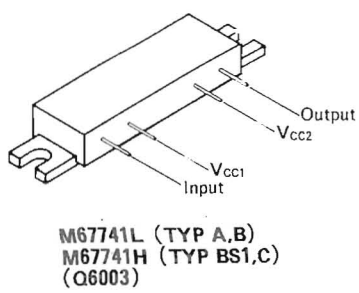
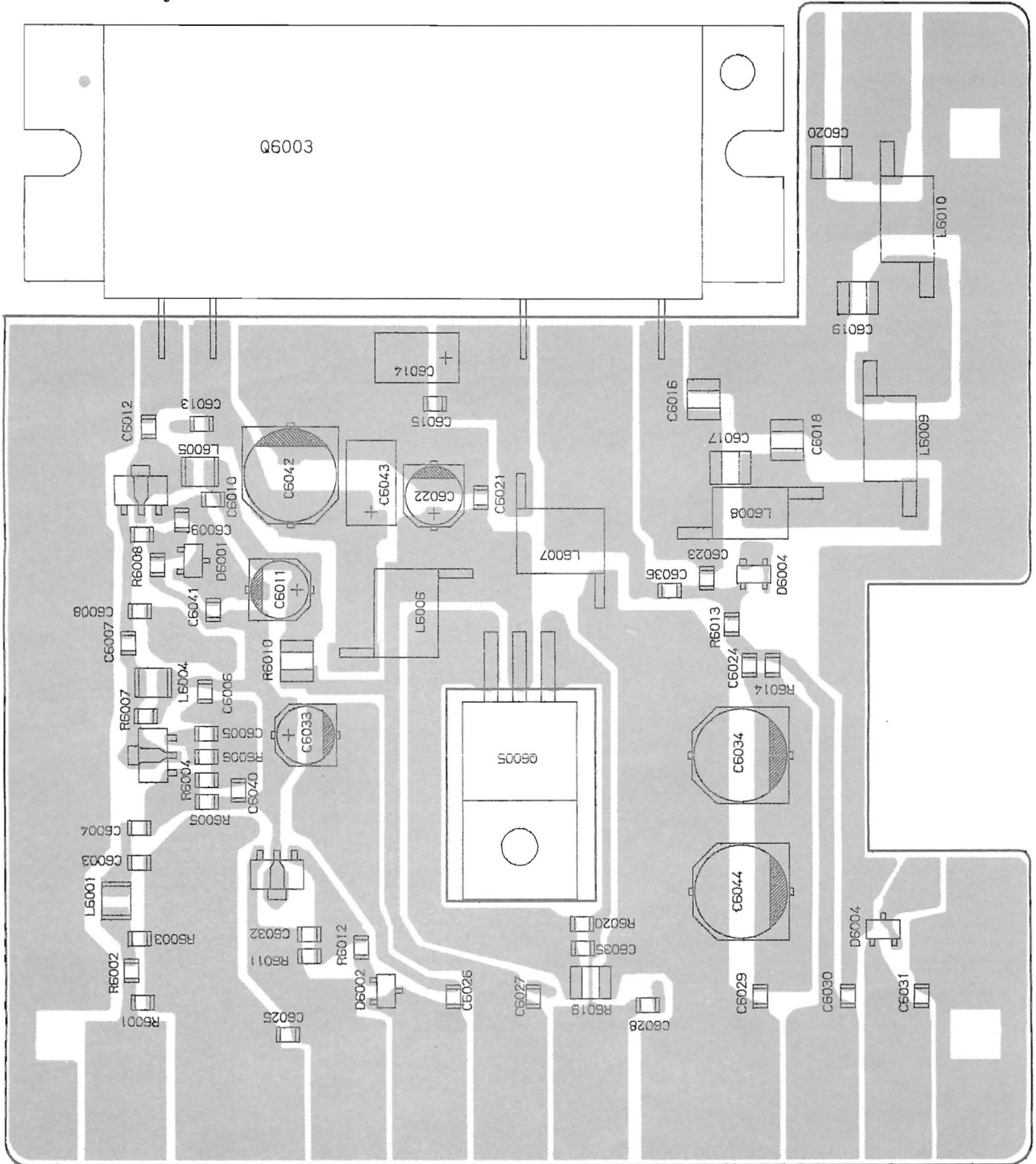

obverse view of component side

REF.	DESCRIPTION	VALUE	WV	TOL.	MFGR'S DESIG	YAESU P/N	VERS.	LOT.	LAY	ADR
*** PA UNIT ***										
	PCB with Components (W/O Q6003)					CS1293001	TYP BS1	6-		
	PCB with Components (W/O Q6003)					CS1293002	TYP A	6-		
	PCB with Components (W/O Q6003)					CS1293003	TYP B	6-		
	PCB with Components (W/O Q6003)					CS1293004	TYP C	6-		
	Printed Circuit Board					F3384000				
C 6003	CHIP CAP.	5pF	50V	CH	GRM40CH050C50PT	K22170206	TYP A	6-		
C 6003	CHIP CAP.	5pF	50V	CH	GRM40CH050C50PT	K22170206	TYP B	6-		
C 6003	CHIP CAP.	8pF	50V	CH	GRM40CH080D50PT	K22170209	TYP BS1			
C 6003	CHIP CAP.	8pF	50V	CH	GRM40CH080D50PT	K22170209	TYP C	6-		
C 6004	CHIP CAP.	47pF	50V	CH	GRM40CH470J50PT	K22170227	TYP A	6-		
C 6004	CHIP CAP.	47pF	50V	CH	GRM40CH470J50PT	K22170227	TYP B	6-		
C 6004	CHIP CAP.	0.001uF	50V	B	GRM40B102M50PT	K22170805	TYP BS1			
C 6004	CHIP CAP.	0.001uF	50V	B	GRM40B102M50PT	K22170805	TYP C	6-		
C 6005	CHIP CAP.	0.01uF	50V	B	GRM40B103M50PT	K22170817				
C 6006	CHIP CAP.	0.001uF	50V	B	GRM40B102M50PT	K22170805				
C 6007	CHIP CAP.	15pF	50V	CH	GRM40CH150J50PT	K22170215	TYP A	6-		
C 6007	CHIP CAP.	15pF	50V	CH	GRM40CH150J50PT	K22170215	TYP B	6-		
C 6007	CHIP CAP.	39pF	50V	CH	GRM40CH390J50PT	K22170225	TYP BS1			
C 6007	CHIP CAP.	39pF	50V	CH	GRM40CH390J50PT	K22170225	TYP C	6-		
C 6008	CHIP CAP.	27pF	50V	CH	GRM40CH270J50PT	K22170221	TYP A	6-		
C 6008	CHIP CAP.	27pF	50V	CH	GRM40CH270J50PT	K22170221	TYP B	6-		
C 6008	CHIP CAP.	15pF	50V	CH	GRM40CH150J50PT	K22170215	TYP BS1			
C 6008	CHIP CAP.	15pF	50V	CH	GRM40CH150J50PT	K22170215	TYP C	6-		
C 6009	CHIP CAP.	0.001uF	50V	B	GRM40B102M50PT	K22170805				
C 6010	CHIP CAP.	0.001uF	50V	B	GRM40B102M50PT	K22170805				
C 6011	AL. ELECTRO. CAP.	10uF	25V		ECEV1EV100SP	K48140003				
C 6012	CHIP CAP.	12pF	50V	CH	GRM40CH120J50PT	K22170213	TYP A	6-		
C 6012	CHIP CAP.	18pF	50V	CH	GRM40CH180J50PT	K22170217	TYP B	6-		
C 6012	CHIP CAP.	18pF	50V	CH	GRM40CH180J50PT	K22170217	TYP BS1			
C 6012	CHIP CAP.	18pF	50V	CH	GRM40CH180J50PT	K22170217	TYP C	6-		
C 6013	CHIP CAP.	0.001uF	50V	B	GRM40B102M50PT	K22170805				
C 6014	TANTALUM CHIP CAP.	10uF	25V		TESVD1E106M12R	K78140018				
C 6015	CHIP CAP.	0.001uF	50V	B	GRM40B102M50PT	K22170805				
C 6016	CHIP CAP.	12pF	500V	CH	GRM42-2CH120J500PT	K22275215	TYP A	6-		
C 6016	CHIP CAP.	12pF	500V	CH	GRM42-2CH120J500PT	K22275215	TYP B	6-		
C 6016	CHIP CAP.	18pF	500V	CH	GRM42-2CH180J500PT	K22275219	TYP BS1			
C 6016	CHIP CAP.	12pF	500V	CH	GRM42-2CH120J500PT	K22275215	TYP C	6-		
C 6017	CHIP CAP.	6pF	500V	CH	GRM42-2CH060D500PT	K22275209	TYP A	6-		
C 6017	CHIP CAP.	5pF	500V	CH	GRM42-2CH050C500PT	K22275208	TYP B	6-		
C 6017	CHIP CAP.	7pF	500V	CH	GRM42-2CH070D500PT	K22275210	TYP BS1			
C 6017	CHIP CAP.	5pF	500V	CH	GRM42-2CH050C500PT	K22275208	TYP C	6-		
C 6018	CHIP CAP.	33pF	500V	CH	GRM42-2CH330J500PT	K22275225	TYP A	6-		
C 6018	CHIP CAP.	33pF	500V	CH	GRM42-2CH330J500PT	K22275225	TYP B	6-		
C 6018	CHIP CAP.	39pF	500V	CH	GRM42-2CH390J500PT	K22275227	TYP BS1			
C 6018	CHIP CAP.	27pF	500V	CH	GRM42-2CH270J500PT	K22275223	TYP C	6-		
C 6019	CHIP CAP.	33pF	500V	CH	GRM42-2CH330J500PT	K22275225				
C 6020	CHIP CAP.	12pF	500V	CH	GRM42-2CH120J500PT	K22275215	TYP A	6-		
C 6020	CHIP CAP.	12pF	500V	CH	GRM42-2CH120J500PT	K22275215	TYP B	6-		
C 6020	CHIP CAP.	22pF	500V	CH	GRM42-2CH220J500PT	K22275221	TYP BS1			
C 6020	CHIP CAP.	18pF	500V	CH	GRM42-2CH180J500PT	K22275219	TYP C	6-		

REF.	DESCRIPTION	VALUE	WV	TOL.	MFGR'S DESIG	YAESU P/N	VERS.	LOT.	LAY	ADR
C 6021	CHIP CAP.	0.001uF	50V	B	GRM40B102M50PT	K22170805				
C 6022	AL. ELECTRO. CAP.	10uF	25V		ECEV1EV100SP	K48140003				
C 6023	CHIP CAP.	1pF	50V	CK	GRM40CK010C50PT	K22170202				
C 6024	CHIP CAP.	0.001uF	50V	B	GRM40B102M50PT	K22170805				
C 6025	CHIP CAP.	0.001uF	50V	B	GRM40B102M50PT	K22170805				
C 6026	CHIP CAP.	0.001uF	50V	B	GRM40B102M50PT	K22170805				
C 6027	CHIP CAP.	0.001uF	50V	B	GRM40B102M50PT	K22170805				
C 6028	CHIP CAP.	0.001uF	50V	B	GRM40B102M50PT	K22170805				
C 6029	CHIP CAP.	0.001uF	50V	B	GRM40B102M50PT	K22170805				
C 6030	CHIP CAP.	0.001uF	50V	B	GRM40B102M50PT	K22170805				
C 6031	CHIP CAP.	0.001uF	50V	B	GRM40B102M50PT	K22170805				
C 6032	CHIP CAP.	0.001uF	50V	B	GRM40B102M50PT	K22170805				
C 6033	AL. ELECTRO. CAP.	10uF	25V		ECEV1EV100SP	K48140003				
C 6034	AL. ELECTRO. CAP.	47uF	25V		ECEV1EG470P	K48140004				
C 6035	CHIP CAP.	0.001uF	50V	B	GRM40B102M50PT	K22170805				
C 6036	CHIP CAP.	3pF	50V	CJ	GRM40CJ030C50PT	K22170204				
C 6040	CHIP CAP.	0.001uF	50V	B	GRM40B102M50PT	K22170805				
C 6041	CHIP CAP.	0.001uF	50V	B	GRM40B102M50PT	K22170805				
C 6042	AL. ELECTRO. CAP.	47uF	25V		ECEV1EG470P	K48140004				
C 6043	TANTALUM CHIP CAP.	10uF	25V		TESVD1E106M12R	K78140018				
C 6044	AL. ELECTRO. CAP.	47uF	25V		ECEV1EG470P	K48140004				
D 6001	DIODE				1SS226 TE85R	G2070003				
D 6002	DIODE				1SS226 TE85R	G2070003				
D 6003	DIODE				1SS319 TE85R	G2070080				
D 6004	DIODE				1SS226 TE85R	G2070003				
J 6001	CONNECTOR				BNC-RM-1(W/O LUG)	P1090773A				
J 6002	CONNECTOR				BNC-LR	P1090254				
L 6001	CHIP COIL	0.022uH			LQN2A22NM	L1690002				
L 6004	CHIP COIL	0.1uH			LQN2AR10K	L1690011	TYP A	6-		
L 6004	CHIP COIL	0.1uH			LQN2AR10K	L1690011	TYP B	6-		
L 6004	CHIP COIL	0.056uH			LQN2A56NM	L1690008	TYP BS1			
L 6004	CHIP COIL	0.056uH			LQN2A56NM	L1690008	TYP C	6-		
L 6005	CHIP COIL	0.1uH			LQN2AR10K	L1690011	TYP A	6-		
L 6005	CHIP COIL	0.056uH			LQN2A56NM	L1690008	TYP B	6-		
L 6005	CHIP COIL	0.056uH			LQN2A56NM	L1690008	TYP BS1			
L 6005	CHIP COIL	0.056uH			LQN2A56NM	L1690008	TYP C	6-		
L 6006	COIL				8. 5T4. 0D0. 8UEW R	L0022203				
L 6007	COIL				8. 5T4. 0D0. 8UEW R	L0022203				
L 6008	COIL				3. 5T4. 5D1. 2UEW R	L0022258	TYP A	6-		
L 6008	COIL				3. 5T4. 5D1. 2UEW R	L0022258	TYP B	6-		
L 6008	COIL				2. 5T4. 5D1. 0UEW R	L0022204	TYP BS1			
L 6008	COIL				2. 5T5. 0D1. 0UEW R	L0022261	TYP C	6-		
L 6009	COIL				3. 5T5. 0D1. 2UEW R	L0022205	TYP A	6-		
L 6009	COIL				3. 5T5. 0D1. 2UEW R	L0022205	TYP B	6-		
L 6009	COIL				3. 5T5. 0D1. 2UEW R	L0022205	TYP BS1			
L 6009	COIL				3. 5T4. 5D1. 2UEW R	L0022258	TYP C	6-		
L 6010	COIL				3. 5T4. 5D1. 2UEW R	L0022258	TYP A	6-		
L 6010	COIL				3. 5T4. 5D1. 2UEW R	L0022258	TYP B	6-		
L 6010	COIL				3. 5T5. 0D1. 2UEW R	L0022205	TYP BS1			
L 6010	COIL				3. 5T4. 0D1. 0UEW R	L0022260	TYP C	6-		

REF.	DESCRIPTION	VALUE	WV	TOL.	MFGR'S DESIG	YAESU P/N	VERS.	LOT.	LAY ADR
Q 6001	TRANSISTOR				2SC2954-T2	G3329547			
Q 6002	TRANSISTOR				2SC2954-T2	G3329547			
Q 6003	IC				M67741L-01	G1091623	TYP A	6-	
Q 6003	IC				M67741L-01	G1091623	TYP B	6-	
Q 6003	IC				M67741H-01	G1091622	TYP BS1		
Q 6003	IC				M67741H-01	G1091622	TYP C	6-	
Q 6004	TRANSISTOR				2SB1132 T100 R	G3211327R			
Q 6005	TRANSISTOR				2SB1134R	G3211340R			
R 6001	CHIP RES.	470	1/10W	5%	RMC1/10T 471J	J24205471			
R 6002	CHIP RES.	12	1/10W	5%	RMC1/10T 120J	J24205120			
R 6003	CHIP RES.	470	1/10W	5%	RMC1/10T 471J	J24205471			
R 6004	CHIP RES.	1.2K	1/10W	5%	RMC1/10T 122J	J24205122			
R 6005	CHIP RES.	6.8K	1/10W	5%	RMC1/10T 682J	J24205682			
R 6006	CHIP RES.	56	1/10W	5%	RMC1/10T 560J	J24205560			
R 6007	CHIP RES.	100	1/10W	5%	RMC1/10T 101J	J24205101			
R 6008	CHIP RES.	1.5K	1/10W	5%	RMC1/10T 152J	J24205152			
R 6009	CHIP RES.	100	1/10W	5%	RMC1/10T 101J	J24205101			
R 6010	CHIP RES.	10	1/4W	5%	RMC1/4 100JATP	J24245100			
R 6011	CHIP RES.	1.2K	1/10W	5%	RMC1/10T 122J	J24205122			
R 6012	CHIP RES.	5.6K	1/10W	5%	RMC1/10T 562J	J24205562			
R 6013	CHIP RES.	4.7K	1/10W	5%	RMC1/10T 472J	J24205472			
R 6014	CHIP RES.	100K	1/10W	5%	RMC1/10T 104J	J24205104			
R 6019	CHIP RES.	0	1/4W	5%	RMC1/4 000JATP	J24245000			
R 6020	CHIP RES.	220	1/10W	5%	RMC1/10T 221J	J24205221			
TS6001	THERMAL SWITCH				OHD1-90M	Q9000611			

Notes:

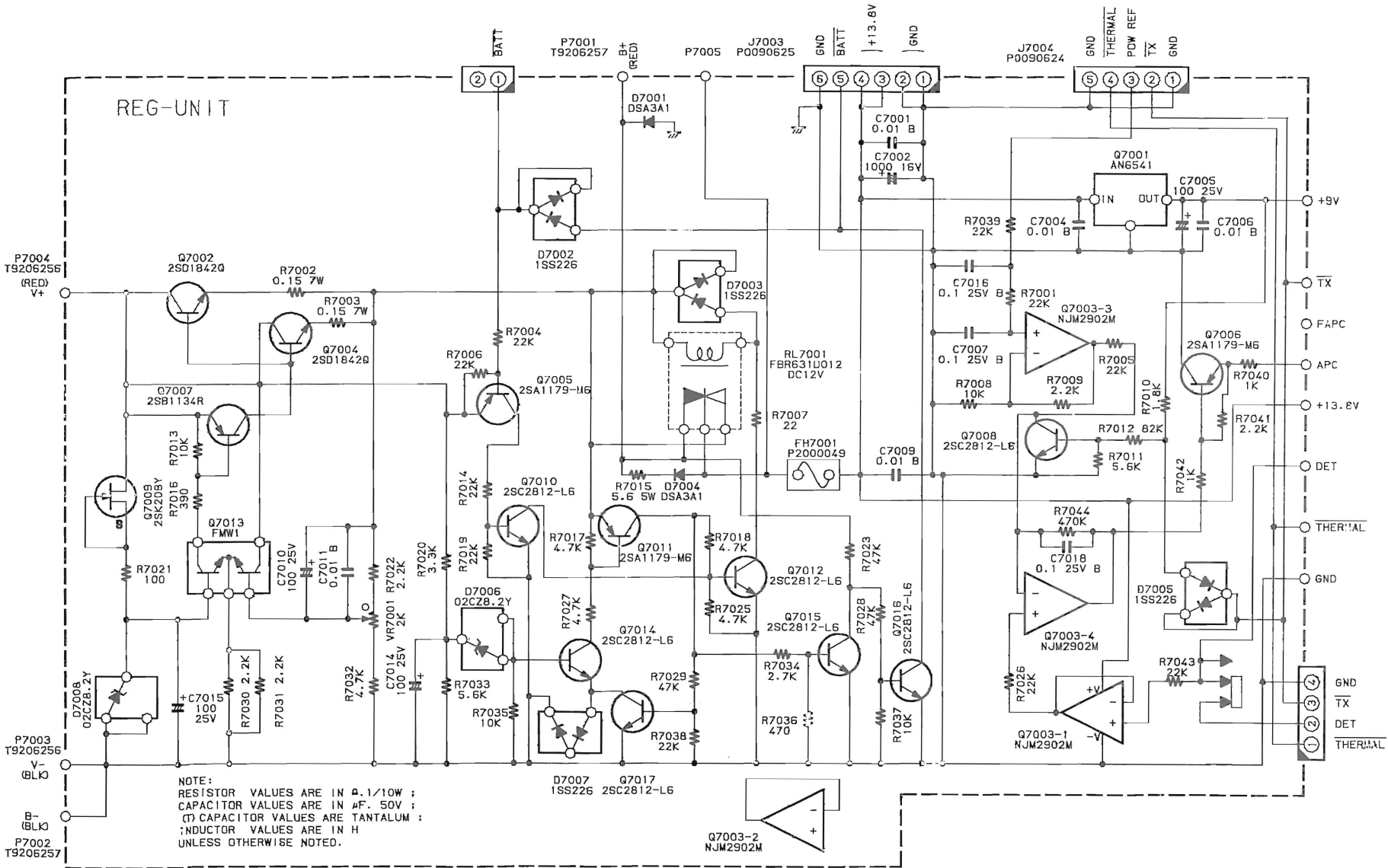

Circuit Diagram

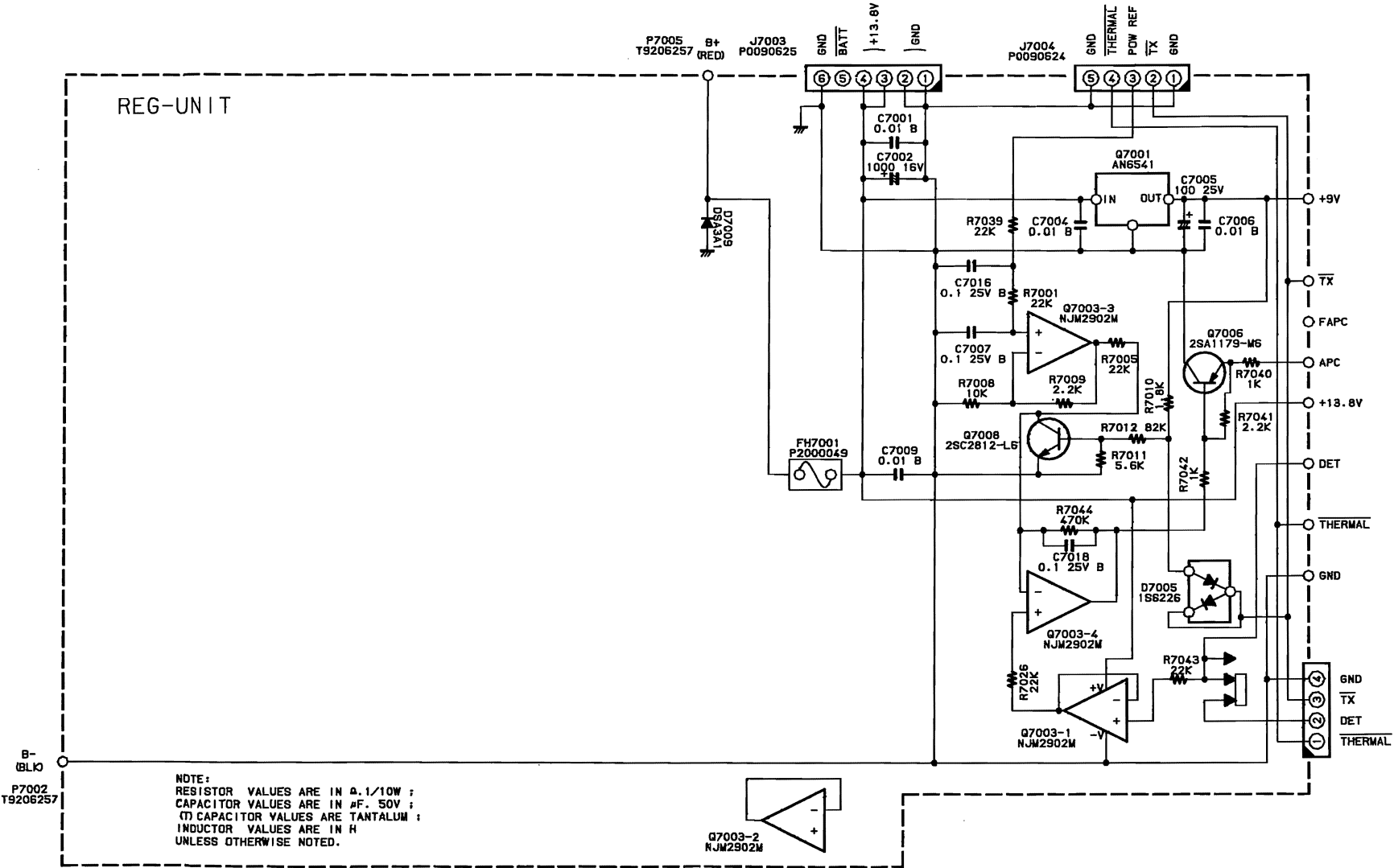

Parts Layout

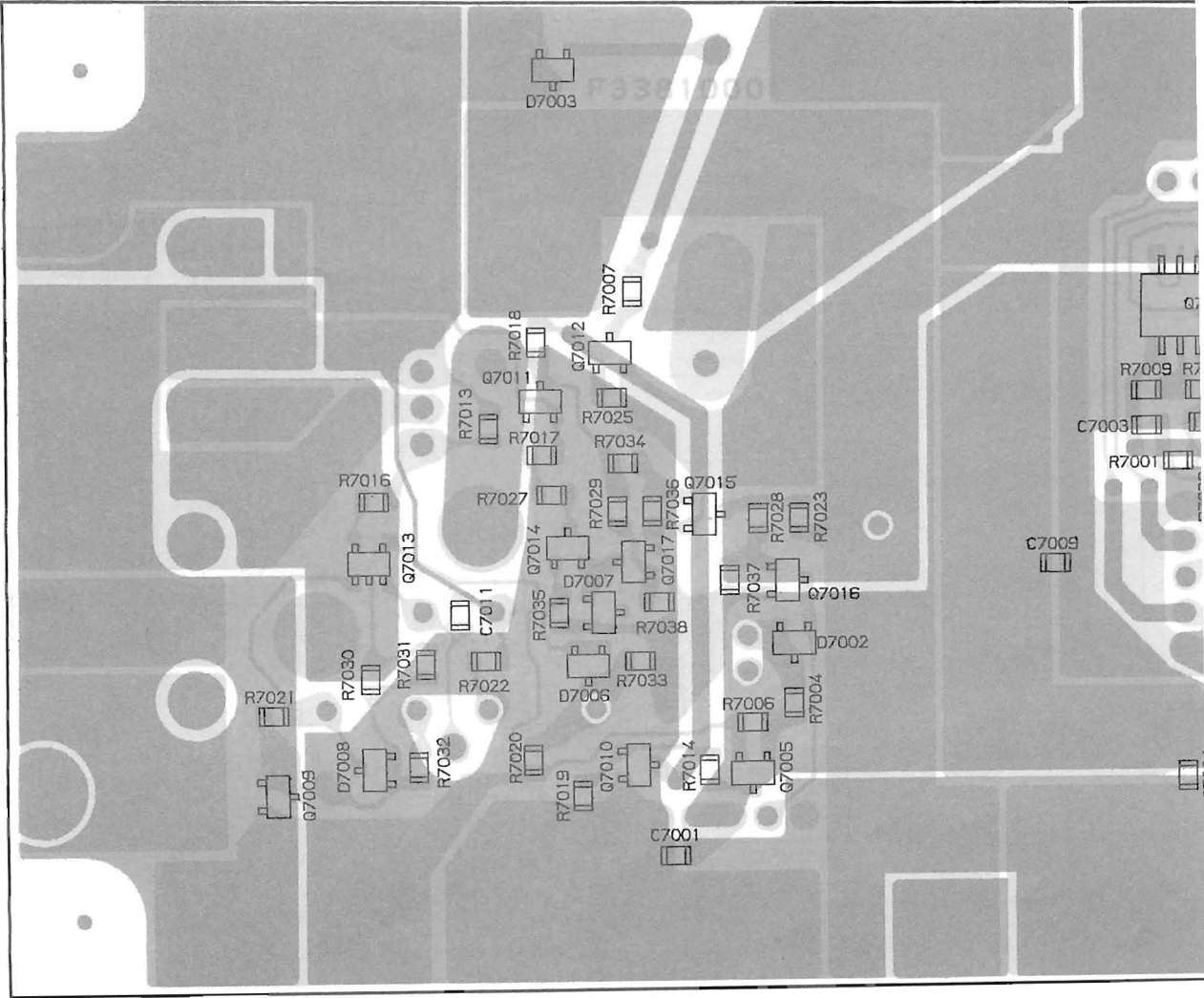

obvers

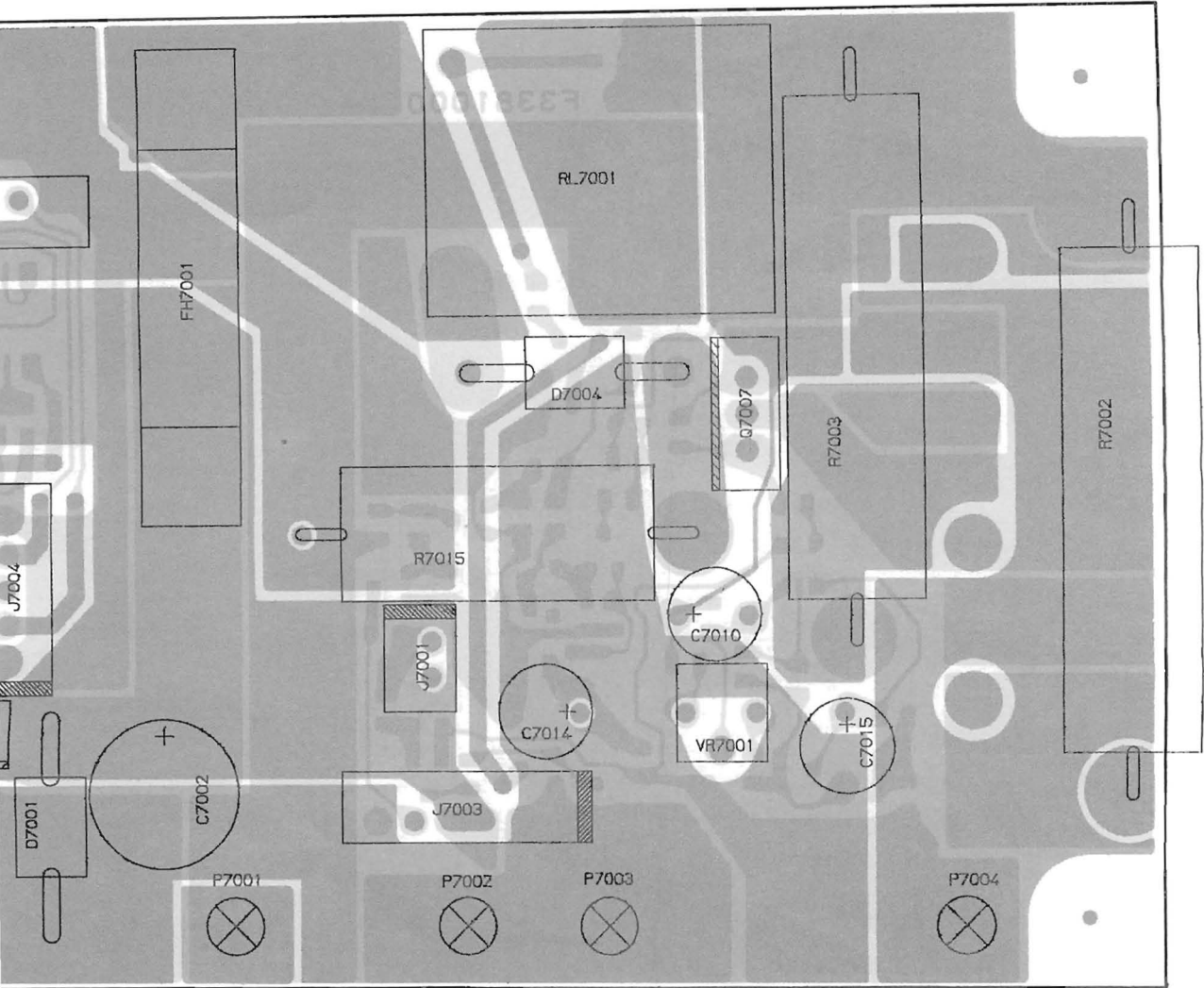

obverse view of component side

Parts Layout

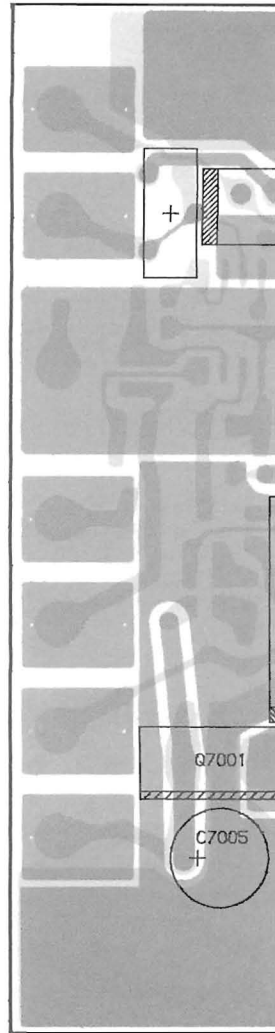
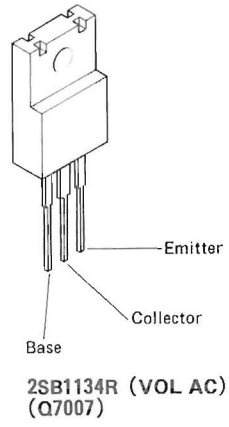
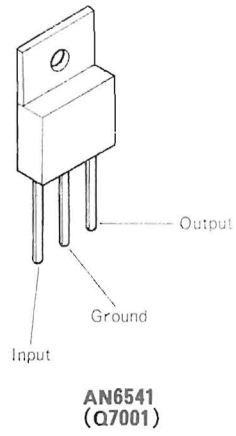

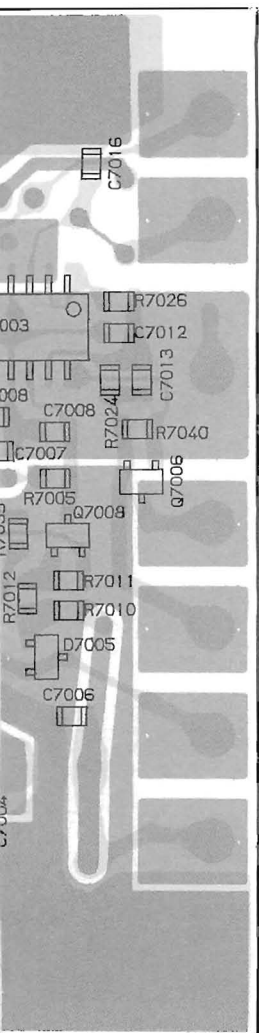

view of chip side

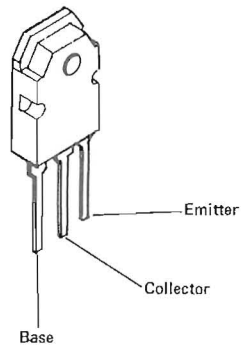

2SD1842Q (VOL AC)
(Q7002,7004)

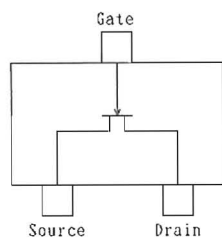

2SK208Y (JY) (VOL AC)
(Q7009)

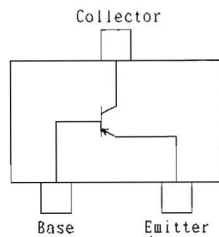

2SA1179 (M6) (VOL AC)
(Q7005,7006,7011)
2SA1179 (M6) (VOL DC)
(Q7006)

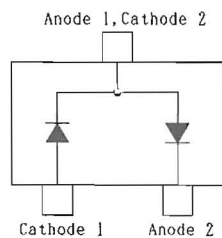

1SS226 (C3) (VOL AC)
(D7002,7003,7005)
7007
1SS226 (C3) (VOL DC)
(D7005)

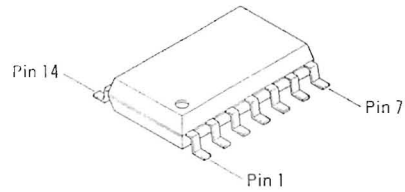

NJM2902M
(Q7003)

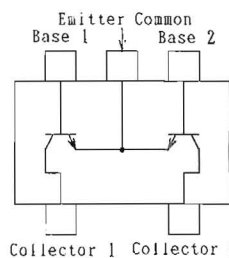

FMW1 (W1) (VOL AC)
(Q7013)

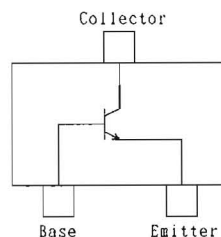

2SC2812 (L6) (VOL AC)
(Q7008,7010,7012)
7014,7015,7016
7017
2SC2812 (L6) (VOL DC)
(Q7008)

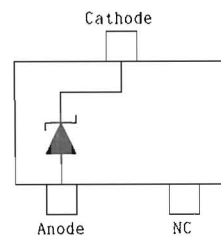

02CZ8.2Y (82) (VOL AC)
(D7006,7008)

REF.	DESCRIPTION	VALUE	WV	TOL.	MFR'S DESIG	YAESU P/N	VERS.	LOT.	LAY	ADR
*** REG UNIT ***										
	PCB with Components					CS1294001	VOL AC			
	PCB with Components					CS1294002	VOL 13.8	5-		
	Printed Circuit Board					F3381000				
C 7001	CHIP CAP.	0.01uF	50V	B	GRM40B103M50PT	K22170817				
C 7002	AL. ELECTRO. CAP.	1000uF	16V		RE3-16V102MS	K40129067				
C 7004	CHIP CAP.	0.01uF	50V	B	GRM40B103M50PT	K22170817				
C 7005	AL. ELECTRO. CAP.	100uF	25V		25V101M6X11TR5	K46140005				
C 7006	CHIP CAP.	0.01uF	50V	B	GRM40B103M50PT	K22170817				
C 7007	CHIP CAP.	0.1uF	25V	B	GRM40B104M25PT	K22140811				
C 7009	CHIP CAP.	0.01uF	50V	B	GRM40B103M50PT	K22170817				
C 7010	AL. ELECTRO. CAP.	100uF	25V		25V101M6X11TR5	K46140005	VOL AC			
C 7011	CHIP CAP.	0.01uF	50V	B	GRM40B103M50PT	K22170817	VOL AC			
C 7012	CHIP CAP.	0.1uF	25V	B	GRM40B104M25PT	K22140811	VOL AC	4-		
C 7014	AL. ELECTRO. CAP.	100uF	25V		25V101M6X11TR5	K46140005	VOL AC			
C 7015	AL. ELECTRO. CAP.	100uF	25V		25V101M6X11TR5	K46140005	VOL AC			
C 7016	CHIP CAP.	0.1uF	25V	B	GRM40B104M25PT	K22140811				
C 7017	CHIP CAP.	0.1uF	25V	B	GRM40B104M25PT	K22140811	VOL AC	4-		
C 7018	CHIP CAP.	0.1uF	25V	B	GRM40B104M25PT	K22140811				
D 7001	DIODE				DSA3A1	G2090445	VOL AC			
D 7002	DIODE				1SS226 TE85R	G2070003	VOL AC			
D 7003	DIODE				1SS226 TE85R	G2070003	VOL AC			
D 7004	DIODE				DSA3A1	G2090445	VOL AC			
D 7005	DIODE				1SS226 TE85R	G2070003				
D 7006	DIODE				02CZ8.2Y TE85R	G2070146	VOL AC			
D 7007	DIODE				1SS226 TE85R	G2070003	VOL AC			
D 7008	DIODE				02CZ8.2Y TE85R	G2070146	VOL AC			
D 7009	DIODE				DSA3A1	G2090445	VOL 13.8	5-		
F 7001	FUSE				10A	Q0000007				
FH7001	FUSE HOLDER				HC1 (2pcs)	P2000049				
J 7003	CONNECTOR				SC25-06WS	P0090625				
J 7004	CONNECTOR				SC25-05WS	P0090624				
P 7001	WIRE-ASS'Y					T9206257	VOL AC			
P 7002	WIRE-ASS'Y					T9206257	VOL 13.8	5-		
P 7002	WIRE-ASS'Y					T9206256	VOL AC	4-		
P 7003	WIRE-ASS'Y					T9206256	VOL AC			
P 7003	WIRE-ASS'Y					T9206257	VOL AC	4-		
P 7004	WIRE-ASS'Y					T9206256	VOL AC	4-		
P 7005	WIRE-ASS'Y					T9206257	VOL 13.8	5-		
Q 7001	IC				AN6541	G1091146				
Q 7002	TRANSISTOR				2SD1842Q	G3418420Q	VOL AC			
Q 7003	IC				NJM2902M-T2	G1090908				
Q 7004	TRANSISTOR				2SD1842Q	G3418420Q	VOL AC			
Q 7005	TRANSISTOR				2SA1179M6-TA	G3111797F	VOL AC			
Q 7006	TRANSISTOR				2SA1179M6-TA	G3111797F				

VXR-5000

REF.	DESCRIPTION	VALUE	WV	TOL.	MFGR'S DESIG	YAESU P/N	VERS.	LOT.	LAY	ADR
Q 7007	TRANSISTOR				2SB1134R	G3211340R	VOL AC			
Q 7008	TRANSISTOR				2SC2812L6-TA	G3328127F				
Q 7009	FET				2SK208Y TE85R	G3802087Y	VOL AC			
Q 7010	TRANSISTOR				2SC2812L6-TA	G3328127F	VOL AC			
Q 7011	TRANSISTOR				2SA1179M6-TA	G3111797F	VOL AC			
Q 7012	TRANSISTOR				2SC2812L6-TA	G3328127F	VOL AC			
Q 7013	TRANSISTOR				FMW1 T98	G3070009	VOL AC			
Q 7014	TRANSISTOR				2SC2812L6-TA	G3328127F	VOL AC			
Q 7015	TRANSISTOR				2SC2812L6-TA	G3328127F	VOL AC			
Q 7016	TRANSISTOR				2SC2812L6-TA	G3328127F	VOL AC			
Q 7017	TRANSISTOR				2SC2812L6-TA	G3328127F	VOL AC			
R 7001	CHIP RES.	22K	1/10W	5%	RMC1/10T 223J	J24205223				
R 7002	CEMENT RES.	0.15	7W	5%	RWBS7 0.15J	J30399001	VOL AC			
R 7003	CEMENT RES.	0.15	7W	5%	RWBS7 0.15J	J30399001	VOL AC			
R 7004	CHIP RES.	22K	1/10W	5%	RMC1/10T 223J	J24205223	VOL AC			
R 7005	CHIP RES.	22K	1/10W	5%	RMC1/10T 223J	J24205223				
R 7006	CHIP RES.	22K	1/10W	5%	RMC1/10T 223J	J24205223	VOL AC			
R 7007	CHIP RES.	22	1/10W	5%	RMC1/10T 220J	J24205220	VOL AC			
R 7008	CHIP RES.	10K	1/10W	5%	RMC1/10T 103J	J24205103				
R 7009	CHIP RES.	2.2K	1/10W	5%	RMC1/10T 222J	J24205222				
R 7010	CHIP RES.	1.8K	1/10W	5%	RMC1/10T 182J	J24205182				
R 7011	CHIP RES.	5.6K	1/10W	5%	RMC1/10T 562J	J24205562				
R 7012	CHIP RES.	82K	1/10W	5%	RMC1/10T 823J	J24205823				
R 7013	CHIP RES.	10K	1/10W	5%	RMC1/10T 103J	J24205103	VOL AC			
R 7014	CHIP RES.	22K	1/10W	5%	RMC1/10T 223J	J24205223	VOL AC			
R 7015	CEMENT RES.	5.6	5W	10%	ERF-5AK5R6	J30376569	VOL AC			
R 7016	CHIP RES.	390	1/10W	5%	RMC1/10T 391J	J24205391	VOL AC			
R 7017	CHIP RES.	4.7K	1/10W	5%	RMC1/10T 472J	J24205472	VOL AC			
R 7018	CHIP RES.	4.7K	1/10W	5%	RMC1/10T 472J	J24205472	VOL AC			
R 7019	CHIP RES.	22K	1/10W	5%	RMC1/10T 223J	J24205223	VOL AC			
R 7020	CHIP RES.	3.3K	1/10W	5%	RMC1/10T 332J	J24205332	VOL AC			
R 7020	CHIP RES.	3.9K	1/10W	5%	RMC1/10T 392J	J24205392	VOL AC	4-		
R 7021	CHIP RES.	100	1/10W	5%	RMC1/10T 101J	J24205101	VOL AC			
R 7022	CHIP RES.	2.2K	1/10W	5%	RMC1/10T 222J	J24205222	VOL AC			
R 7023	CHIP RES.	47K	1/10W	5%	RMC1/10T 473J	J24205473	VOL AC			
R 7025	CHIP RES.	4.7K	1/10W	5%	RMC1/10T 472J	J24205472	VOL AC			
R 7026	CHIP RES.	22K	1/10W	5%	RMC1/10T 223J	J24205223				
R 7027	CHIP RES.	4.7K	1/10W	5%	RMC1/10T 472J	J24205472	VOL AC			
R 7028	CHIP RES.	47K	1/10W	5%	RMC1/10T 473J	J24205473	VOL AC			
R 7029	CHIP RES.	47K	1/10W	5%	RMC1/10T 473J	J24205473	VOL AC			
R 7030	CHIP RES.	2.2K	1/10W	5%	RMC1/10T 222J	J24205222	VOL AC			
R 7031	CHIP RES.	2.2K	1/10W	5%	RMC1/10T 222J	J24205222	VOL AC			
R 7032	CHIP RES.	4.7K	1/10W	5%	RMC1/10T 472J	J24205472	VOL AC			
R 7033	CHIP RES.	5.6K	1/10W	5%	RMC1/10T 562J	J24205562	VOL AC			
R 7033	CHIP RES.	4.7K	1/10W	5%	RMC1/10T 472J	J24205472	VOL AC	4-		
R 7034	CHIP RES.	2.7K	1/10W	5%	RMC1/10T 272J	J24205272	VOL AC			
R 7035	CHIP RES.	10K	1/10W	5%	RMC1/10T 103J	J24205103	VOL AC			
R 7036	CHIP RES.	470	1/10W	5%	RMC1/10T 471J	J24205471	VOL AC			
R 7037	CHIP RES.	10K	1/10W	5%	RMC1/10T 103J	J24205103	VOL AC			
R 7038	CHIP RES.	22K	1/10W	5%	RMC1/10T 223J	J24205223	VOL AC			
R 7039	CHIP RES.	22K	1/10W	5%	RMC1/10T 223J	J24205223				
R 7040	CHIP RES.	1K	1/10W	5%	RMC1/10T 102J	J24205102				
R 7041	CHIP RES.	2.2K	1/10W	5%	RMC1/10T 222J	J24205222				

REF.	DESCRIPTION	VALUE	WV	TOL.	MFGR'S DESIG	YAESU P/N	VERS.	LOT.	LAY	ADR
R 7042	CHIP RES.	1K	1/10W	5%	RMC1/10T 102J	J24205102				
R 7043	CHIP RES.	22K	1/10W	5%	RMC1/10T 223J	J24205223				
R 7044	CHIP RES.	470K	1/10W	5%	RMC1/10T 474J	J24205474				
RL7001	RELAY		DC12V		FBR631D012	M1190062	VOL AC			
VR7001	POT.	2K			EVN-DCAA03B23	J50784202	VOL AC			
	THERMAL CONDUCTOR (2pcs)					Q9000609	VOL AC			

Notes:

Parts Layout

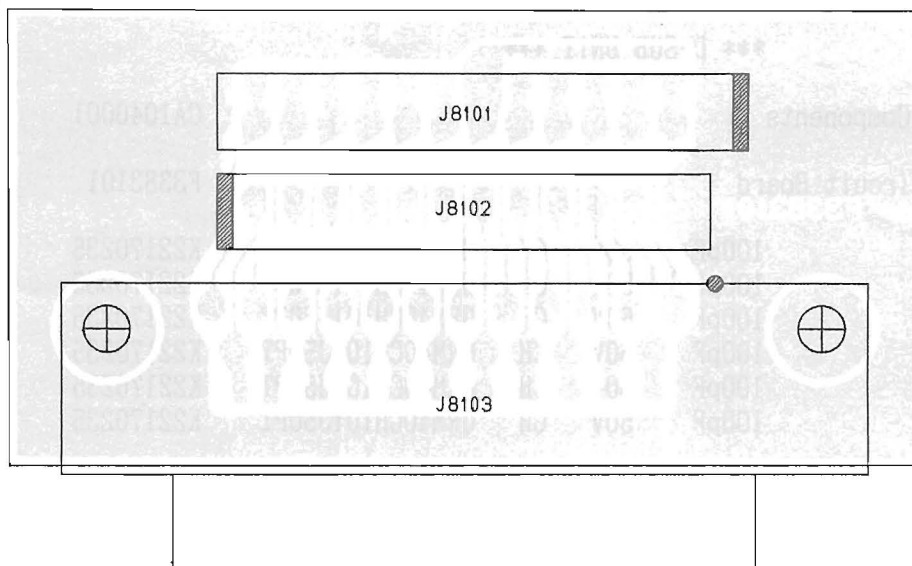

obverse view of component side

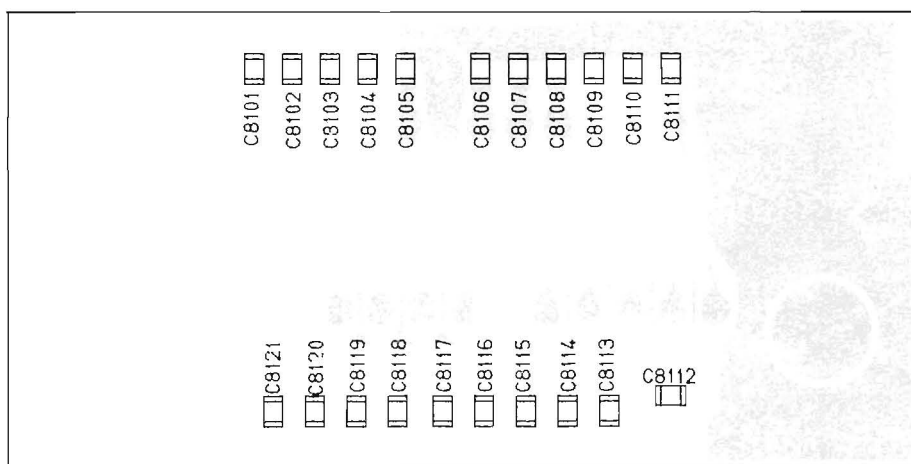

obverse view of chip side

Circuit Diagram

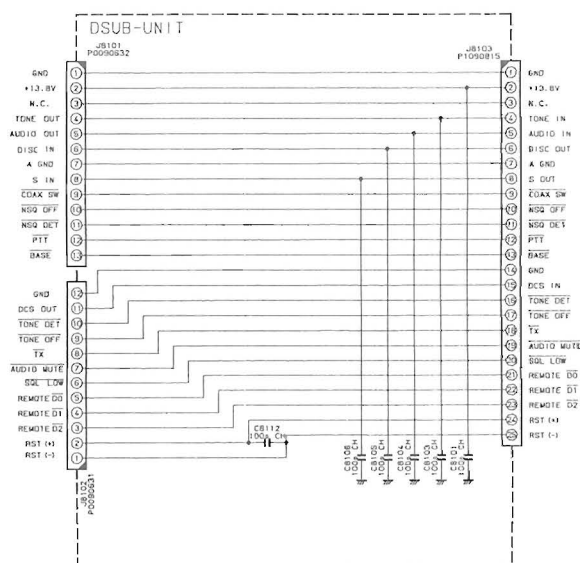

REF.	DESCRIPTION	VALUE	WV	TOL.	MFGR'S DESIG	YAESU P/N	VERS.	LOT.	LAY	ADR
*** D-SUB UNIT ***										
	PCB with Components					CA1040001				
	Printed Circuit Board					F3383101				
C 8101	CHIP CAP.	100pF	50V	CH	GRM40CH101J50PT	K22170235				
C 8103	CHIP CAP.	100pF	50V	CH	GRM40CH101J50PT	K22170235				
C 8104	CHIP CAP.	100pF	50V	CH	GRM40CH101J50PT	K22170235				
C 8105	CHIP CAP.	100pF	50V	CH	GRM40CH101J50PT	K22170235				
C 8106	CHIP CAP.	100pF	50V	CH	GRM40CH101J50PT	K22170235				
C 8112	CHIP CAP.	100pF	50V	CH	GRM40CH101J50PT	K22170235				
J 8101	CONNECTOR				SC25-13WS	P0090632				
J 8102	CONNECTOR				SC25-12WS	P0090631				
J 8103	CONNECTOR				JBY-25S-1A3F	P1090815				

Parts Layout

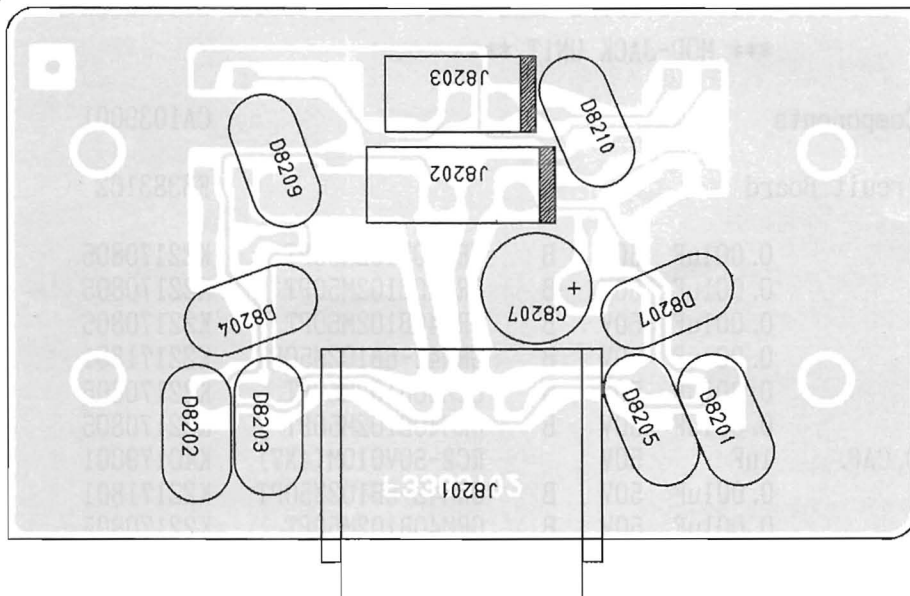

obverse view of component side

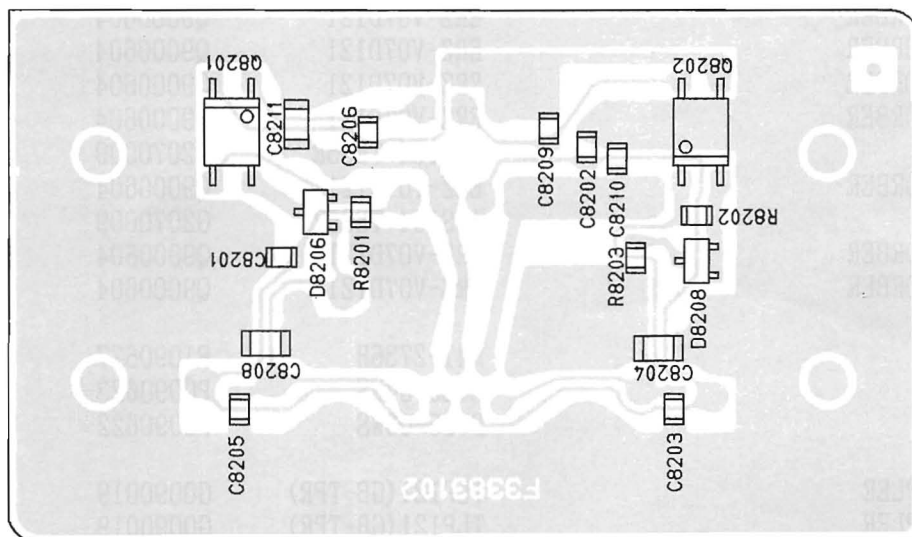

obverse view of chip side

Circuit Diagram

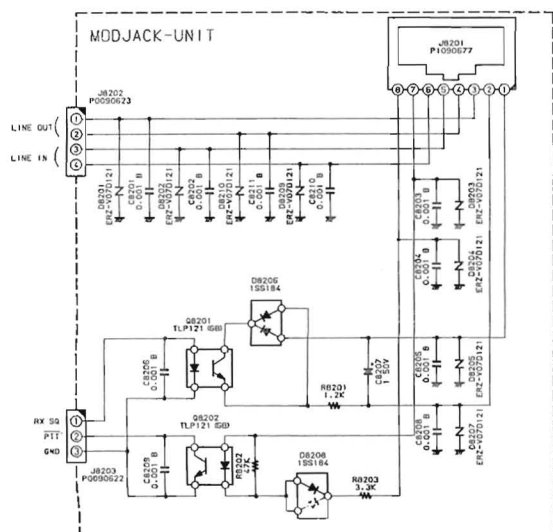

- ① RX SD (+)
- ② RX SD (-)
- ③ LINE IN
- ④ LINE OUT
- ⑤ TX KEY (+)
- ⑥ TX KEY (-)

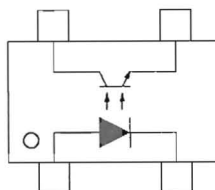

TLP121 (Q8201,8202)

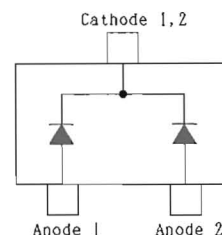

1SS184 (B3) (D8206,8208)

REF.	DESCRIPTION	VALUE	WV	TOL.	MFGR'S DESIG	YAESU P/N	VERS.	LOT.	LAY	ADR
*** MOD-JACK UNIT ***										
	PCB with Components					CA1039001				
	Printed Circuit Board					F3383102				
C 8201	CHIP CAP.	0.001uF	50V	B	GRM40B102M50PT	K22170805				
C 8202	CHIP CAP.	0.001uF	50V	B	GRM40B102M50PT	K22170805				
C 8203	CHIP CAP.	0.001uF	50V	B	GRM40B102M50PT	K22170805				
C 8204	CHIP CAP.	0.001uF	50V	B	GRM42-6B102M50PT	K22171801				
C 8205	CHIP CAP.	0.001uF	50V	B	GRM40B102M50PT	K22170805				
C 8206	CHIP CAP.	0.001uF	50V	B	GRM40B102M50PT	K22170805				
C 8207	AL. ELECTRO. CAP.	1uF	50V		RC2-50V010M(4X7)	K40179001				
C 8208	CHIP CAP.	0.001uF	50V	B	GRM42-6B102M50PT	K22171801				
C 8209	CHIP CAP.	0.001uF	50V	B	GRM40B102M50PT	K22170805				
C 8210	CHIP CAP.	0.001uF	50V	B	GRM40B102M50PT	K22170805				
C 8211	CHIP CAP.	0.001uF	50V	B	GRM42-6B102M50PT	K22171801				
D 8201	SURGE ABSORBER				ERZ-V07D121	Q9000604				
D 8202	SURGE ABSORBER				ERZ-V07D121	Q9000604				
D 8203	SURGE ABSORBER				ERZ-V07D121	Q9000604				
D 8204	SURGE ABSORBER				ERZ-V07D121	Q9000604				
D 8205	SURGE ABSORBER				ERZ-V07D121	Q9000604				
D 8206	DIODE				1SS184 TE85R	G2070009				
D 8207	SURGE ABSORBER				ERZ-V07D121	Q9000604				
D 8208	DIODE				1SS184 TE85R	G2070009				
D 8209	SURGE ABSORBER				ERZ-V07D121	Q9000604				
D 8210	SURGE ABSORBER				ERZ-V07D121	Q9000604				
J 8201	CONNECTOR				R41-2736H	P1090677				
J 8202	CONNECTOR				SC25-04WS	P0090623				
J 8203	CONNECTOR				SC25-03WS	P0090622				
Q 8201	PHOTO COUPLER				TLP121 (GB-TPR)	G0090019				
Q 8202	PHOTO COUPLER				TLP121 (GB-TPR)	G0090019				
R 8201	CHIP RES.	1.2K	1/10W	5%	RMC1/10T 122J	J24205122				
R 8202	CHIP RES.	47K	1/10W	5%	RMC1/10T 473J	J24205473				
R 8203	CHIP RES.	3.3K	1/10W	5%	RMC1/10T 332J	J24205332				

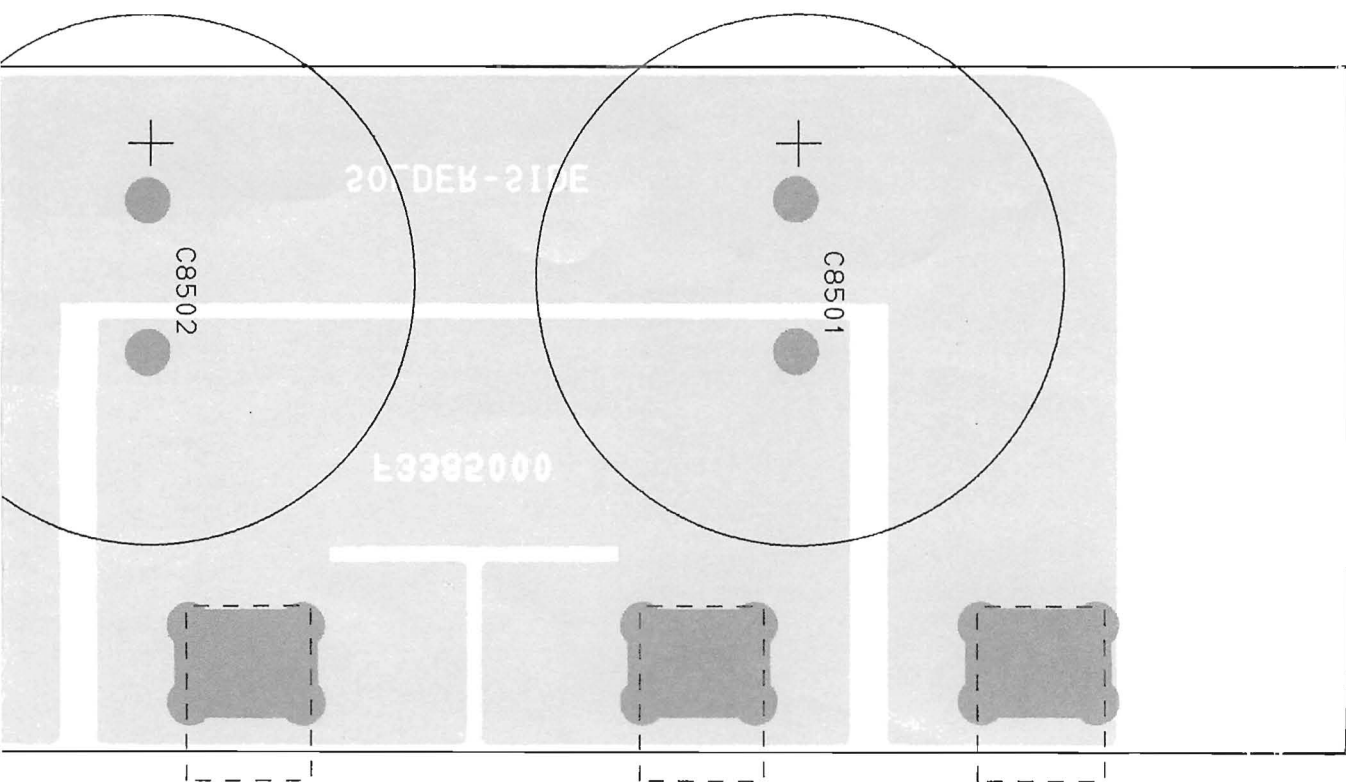

obverse view of component side

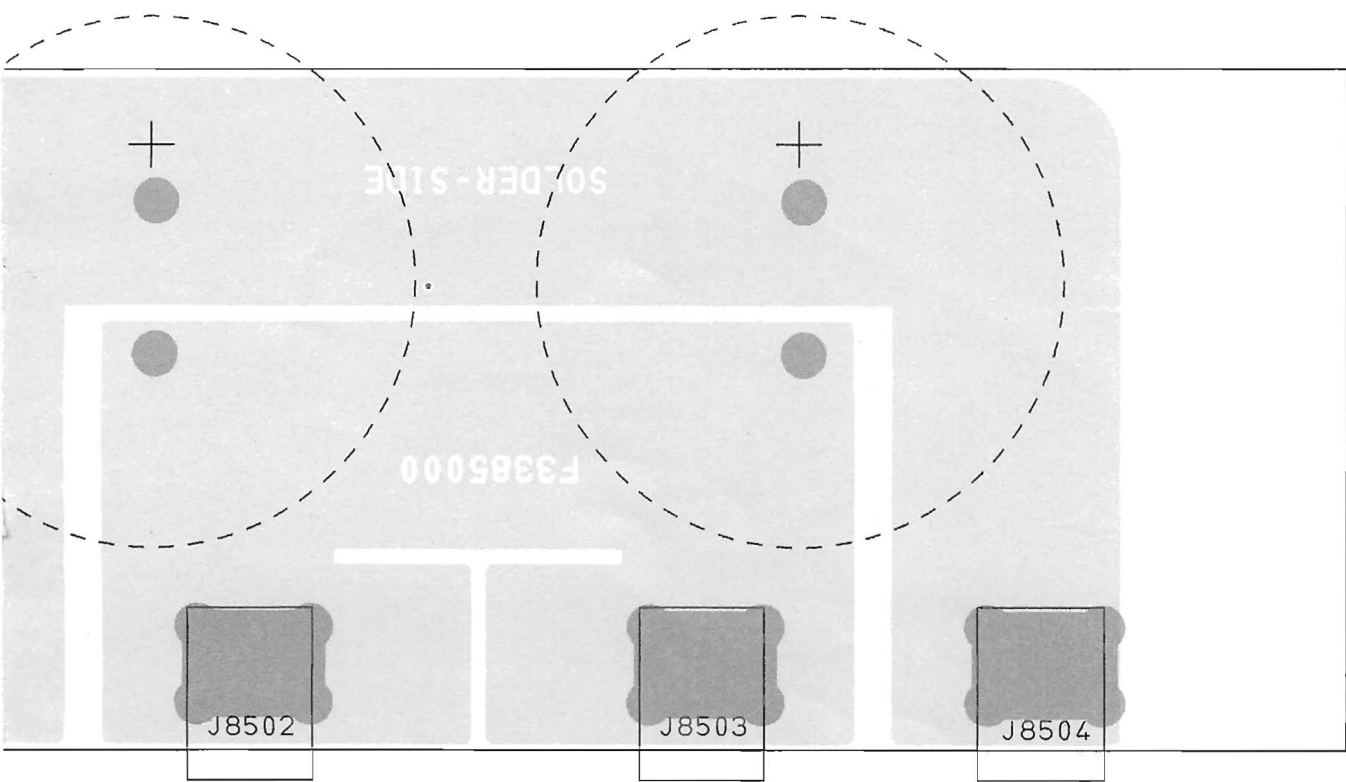

obverse view of solder side

Circuit Diagram

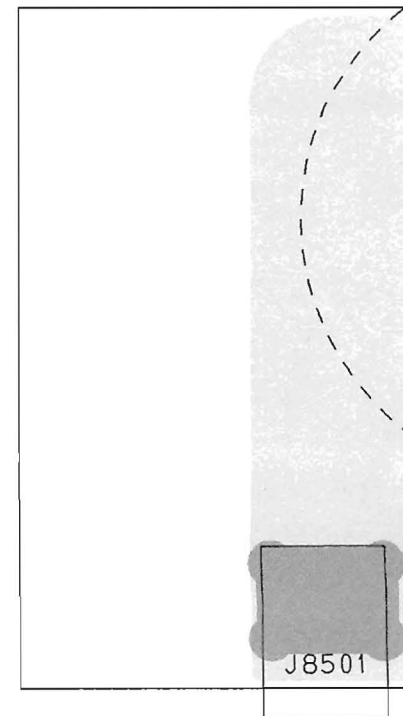
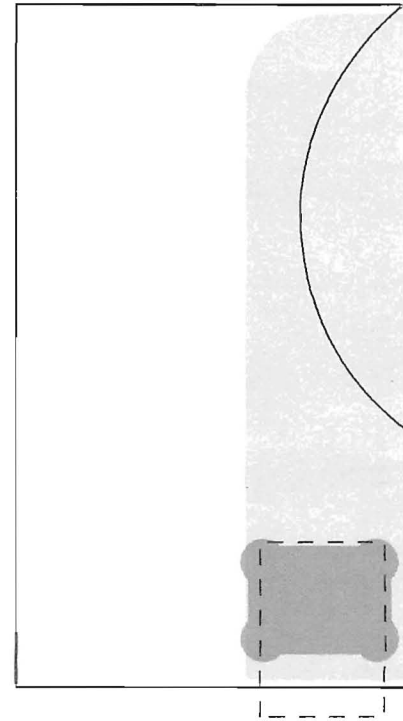
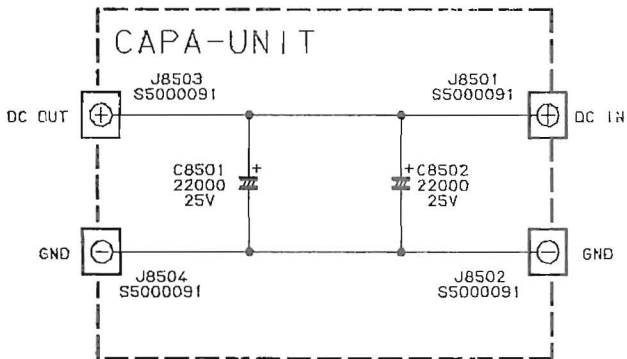

REF.	DESCRIPTION	VALUE	WV	TOL.	MFGR'S DESIG	YAESU P/N	VERS.	LOT.	LAY	ADR
*** CAPA UNIT ***										
	PCB with Components					CA1112001	VOL AC			
	Printed Circuit Board					F3385000				
C 8501	AL. ELECTRO. CAP.	22000uF	25V		ECOS1E223EA	K42140007				
C 8502	AL. ELECTRO. CAP.	22000uF	25V		ECOS1E223EA	K42140007				
J 8501	TERMINAL				Y-105	S5000091				
J 8502	TERMINAL				Y-105	S5000091				
J 8503	TERMINAL				Y-105	S5000091				
J 8504	TERMINAL				Y-105	S5000091				

Notes:

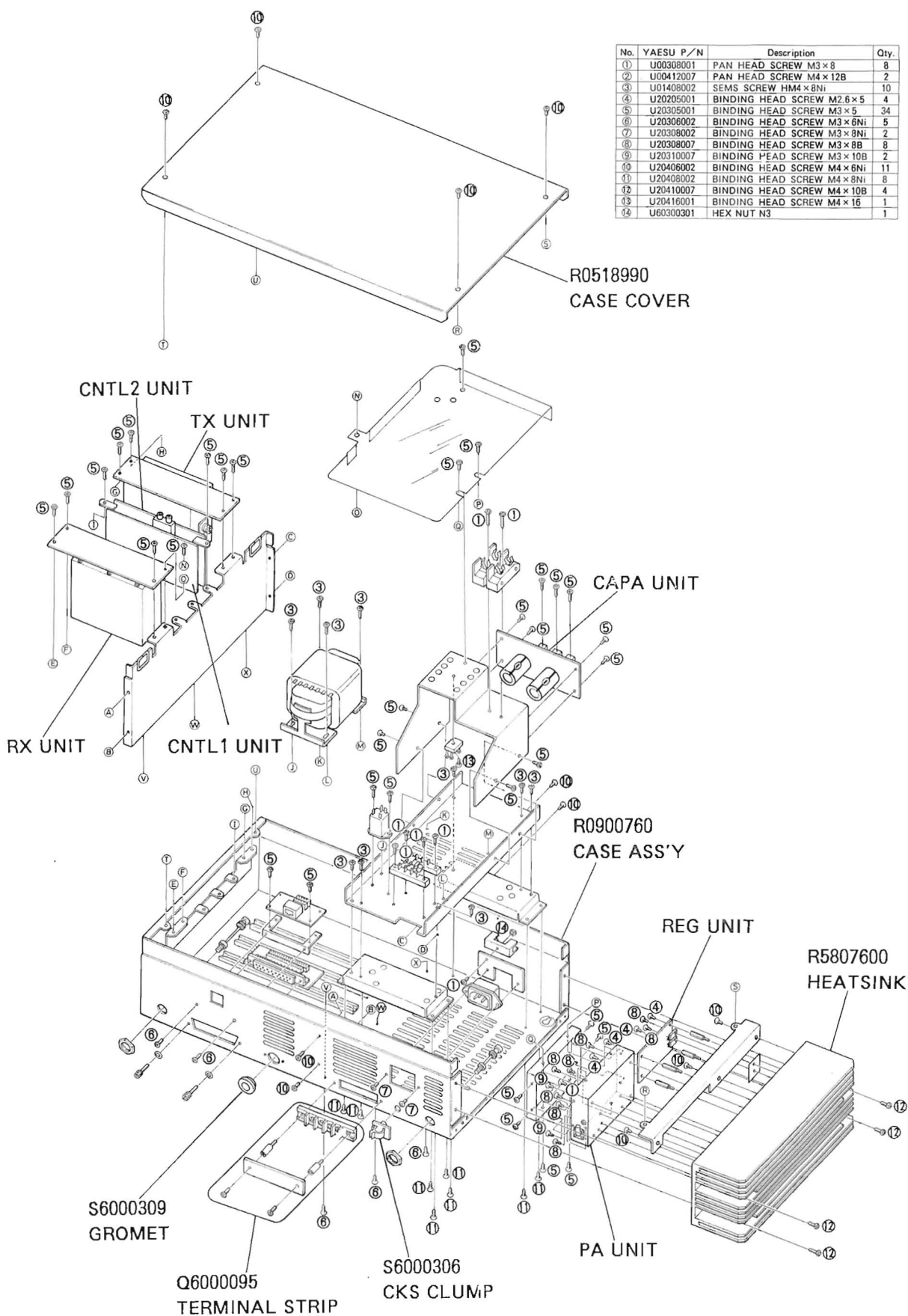

Non-designated parts are available only as part of a designated assembly.

REF.	DESCRIPTION	VALUE	WV	TOL.	MFGR'S DESIG	YAESU P/N	VERS.	LOT.	LAY	ADR
C 0001	AL. ELECTRO. CAP.	1000uF	25V		RE2-25V102M	K40149034				
C 0002	CERAMIC CAP.	0.01uF	2KV	E	ECKDNS103ME	K12329001	VOL AC			
C 0003	CERAMIC CAP.	0.01uF	2KV	E	ECKDNS103ME	K12329001	VOL AC			
C 0004	FEED THRU CAP.	0.001uF	50V	E	ECKY1H102ZE2	K21170006				
C 0005	FEED THRU CAP.	0.001uF	50V	E	ECKY1H102ZE2	K21170006				
C 0006	FEED THRU CAP.	0.001uF	50V	E	ECKY1H102ZE2	K21170006				
C 0007	FEED THRU CAP.	0.001uF	50V	E	ECKY1H102ZE2	K21170006				
C 0008	FEED THRU CAP.	0.001uF	50V	E	ECKY1H102ZE2	K21170006				
C 0009	FEED THRU CAP.	0.001uF	50V	E	ECKY1H102ZE2	K21170006				
C 0010	FEED THRU CAP.	0.001uF	50V	E	ECKY1H102ZE2	K21170006				
C 0011	CERAMIC CAP.	0.1uF	50V	F	UP050F104Z-A-B	K28179003				
C 0012	CERAMIC CAP.	0.1uF	50V	F	UP050F104Z-A-B	K28179003				
C 0013	CERAMIC CAP.	0.1uF	50V	F	UP050F104Z-A-B	K28179003				
C 0014	CERAMIC CAP.	0.1uF	50V	F	UP050F104Z-A-B	K28179003				
D 0001	DIODE				10E1	G2090306				
D 0002	DIODE				S25VB20	G2090361				
F 0001	FUSE				5A	Q0000005	VOL 22			
F 0001	FUSE				3A	Q0000004	VOL 43			
F 0002	FUSE				20A	Q0000009	VOL AC			
FH0001	FUSE HOLDER				H203	P2000025	VOL AC			
FH0002	FUSE HOLDER				354021-BL	P2000051				
J 0001	CONNECTOR				AP-300-3A1 (V)	P0090811	VOL AC			
J 0002	TERMINAL STRIP				MT8-4C	Q6000095				
J 0003	TERMINAL				ML-3182 4P	Q6000075				
J 0004	TERMINAL				ML-3182 4P	Q6000075				
P 0001	WIRE-ASS'Y					T9206275B				
P 0002	WIRE-ASS'Y					T9317964				
P 0003	CT-CORD				BNC-N 170mm	T9101433				
P 0004	CT-CORD				BNC-N 170mm	T9101433				
P 0005	CT-CORD				BNC-BNC 400mm	T9101434				
P 0006	WIRE-ASS'Y					T9206276				
P 0007	WIRE-ASS'Y					T9206278				
P 0008	WIRE-ASS'Y					T9206279				
P 0009	WIRE-ASS'Y					T9206280				
P 0010	WIRE-ASS'Y					T9206281				
P 0011	WIRE-ASS'Y					T9206282				
P 0012	WIRE-ASS'Y					T9206283				
P 0013	WIRE-ASS'Y					T9206284				
P 0014	WIRE-ASS'Y					T9206286				
P 0015	WIRE-ASS'Y					T9206287				
P 0016	WIRE-ASS'Y					T9317963				
PT0001	PWR-TRANSFORMER					L3030142				
R 0001	CARBON FILM RES.	27	1/2W	5%	RD12TJ270 27	J01275270				
R 0002	CEMENT RES.	10	5W	5%	ERF-5AJ100	J30375100				
RL0001	RELAY		DC12V		G4W-11123A-B	M1090018				
S 0001	SCREW (2pcs)				KFS-4S-BIW	S5000158				

This device complies with part 15 of the FCC rules. Operation is subject to the condition that this device does not cause harmful interference.

The users manual or instruction manual for an intentional or unintentional radiator shall caution the user that changes or modifications not expressly approved by the party responsible for compliance could void the user's authority to operate the equipment.

YAESU

Performance without compromise.SM

Copyright © 1993
Yaesu Musen Co., Ltd.
All rights reserved.

*Team Support 2-67 1/1/2/1/1/1
(1/1/1/1/1/1)*

No portion of this manual
may be reproduced
without the permission of
Yaesu Musen Co., Ltd.