

## Introduction

This application note provides examples of high speed LVCMOS driver clock drivers. For high-speed LVCMOS drivers, general rules for high-speed digital board design must be followed. Proper termination is required to ensure signal quality and Electro-Magnetic Interference (EMI) reduction.

There are many different termination schemes for single-ended LVCMOS drivers. This application note discusses parallel termination, AC termination and series termination. The following termination approaches are only general recommendations under ideal conditions. Board designers should consult with their signal integrity engineers or verify through simulations in their system environment.

## Parallel (DC) Termination

The standard termination of an LVCMOS driver in a  $Z_0=50$  ohm transmission line environment is shown in [Figure 1](#). The driver is terminated with 50 ohm pull down to  $V_{TT}=V_{DDO}/2$  at the receiver end. The LVCMOS clock buffer characterization set up is terminated in similar manner using split power supplies approach (see test condition in the datasheet of an LVCMOS driver). In actual applications, the equivalent parallel termination shown in [Figure 2](#) can be used. The LVCMOS parallel termination has the same effect as the standard LVCMOS shown in [Figure 1](#). The parallel termination shown in [Figure 2](#) can eliminate the need of  $V_{TT}=V_{DDO}/2$  power supply (or reference voltage). The power dissipation calculation is described further in application note AN-809.

**Figure 1. LVCMOS Driver Standard Termination**

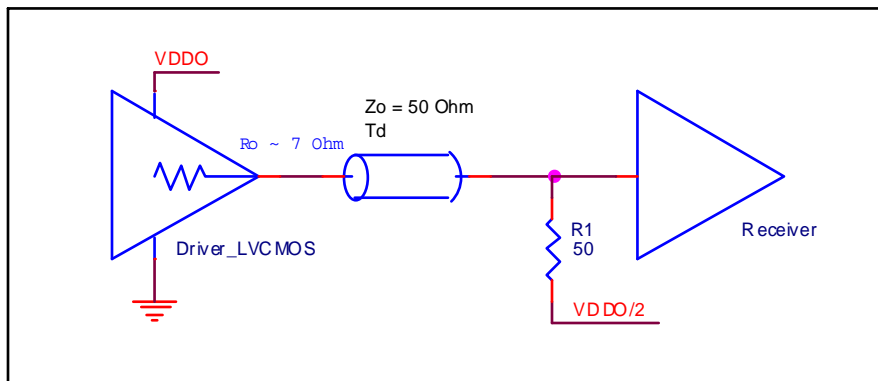

**Figure 2. LVCMOS Parallel Termination**

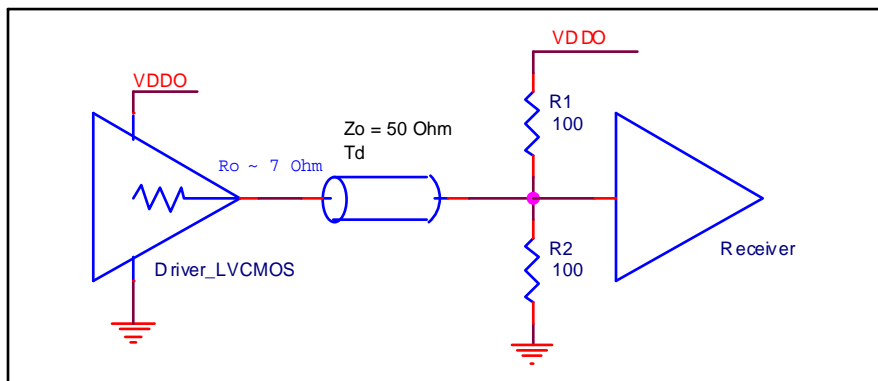

## AC Termination

The LVCMOS driver AC termination in a 50 ohm transmission line environment is shown in [Figure 3](#). The majority of load current is drawn during transient region (i.e. rising edge and falling edge). This termination consumes less power than the parallel termination. The proper value of capacitor C1 depends on the trace delay and capacitance of the transmission line. Some PC board layout or simulation software tools provide a feature of calculating the transmission line capacitance by entering the trace information (see [References](#), [1]).

**Figure 3. AC Termination**

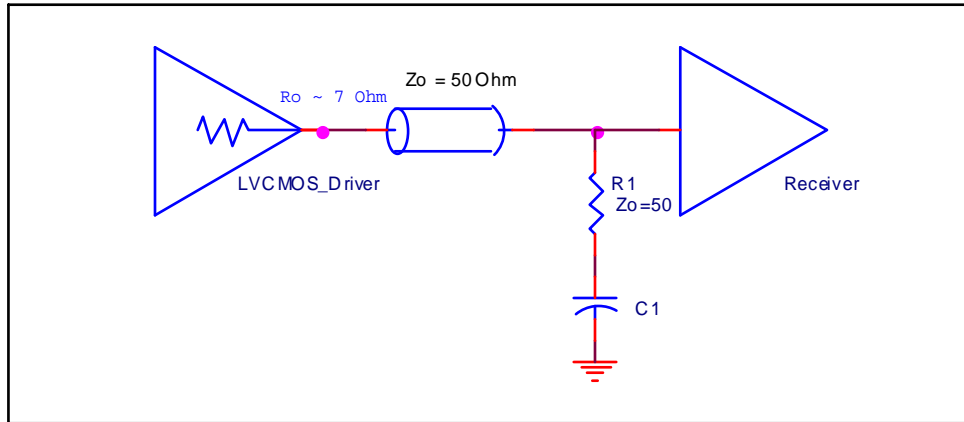

## Series Termination

Series termination is a popular termination scheme for LVCMOS drivers. [Figure 4](#) shows a simple series termination for LVCMOS drivers with output impedance of 7 ohm. The Power Dissipation of this termination scheme is described in a separate document.

The typical output impedance  $R_O$  of a high speed LVCMOS driver is approximately 7 to 16 ohms (some parts might have different  $R_O$  value. Refer to datasheet for the output impedance). For example,  $R_O=7$  ohm, the closest series resistor value,  $R_S$ , can be calculated as follows:

$$R_s = Z_o - R_o = 43 \text{ ohms}$$

In the [Figure 4](#), the footprint for optional series resistor R3 or optional capacitor C1 at the receiver input is recommend for adjusting edge rate or overshoot if necessary.

**Figure 4. One-to-One LVCMOS Series Termination**

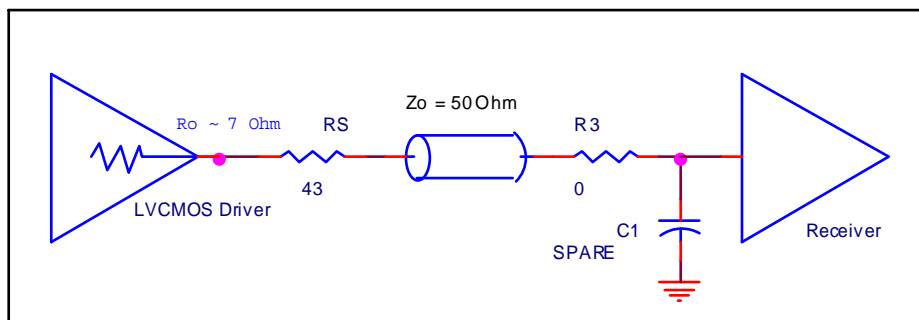

When the number of drivers is not equal to number of receivers as shown in [Figure 6](#), the series resistor value  $R_S$  is calculated as follows:

$$R_s = Z_o - (R_o \times M)/(N)$$

where  $N$  = number of driver;  $M$  = number of receiver

This configuration assumes that all the trace delays and load conditions are equally matched.

For example, one driver driving 2 receivers as shown in Figure 5, with N=1 and M=2, the series resistor is calculated to be  $R_S = 36$  ohms. The trace delays  $T_d$  on TL1 are equal. The loading conditions on both receivers should also be equal.

**Figure 5. Series Termination for One LVC MOS Driver Driving Two Receivers**

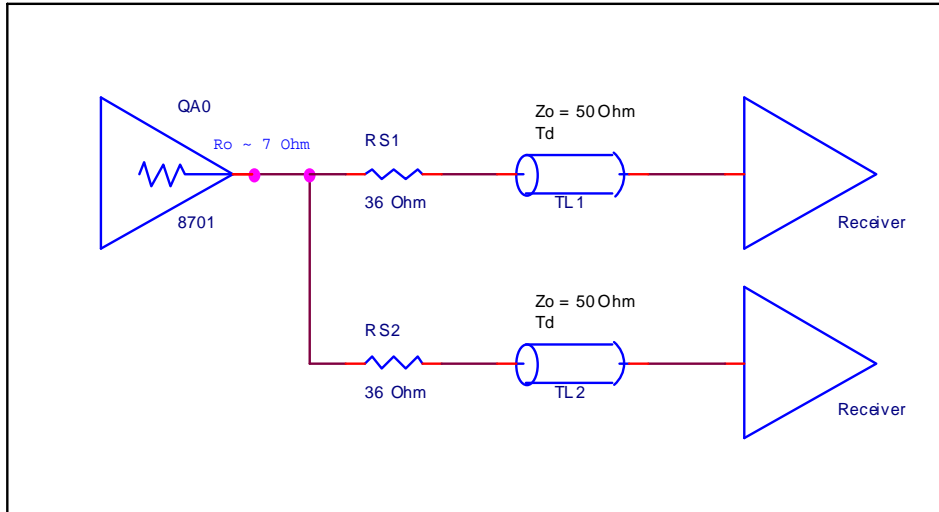

For 5 drivers driving 6 receivers, the closest series resistor can be calculated as follows:

**$N=5, M=6, Z_0=50$  Ohms,  $R_o = 7$  ohm**

**$R_s = 50 - (7 \times 6)/5 = 41.6$  ohm**

The result above is straight from calculations. The closest available resistor value should be chosen.

**Figure 6. Tie N Outputs Together to Drive M Receivers**

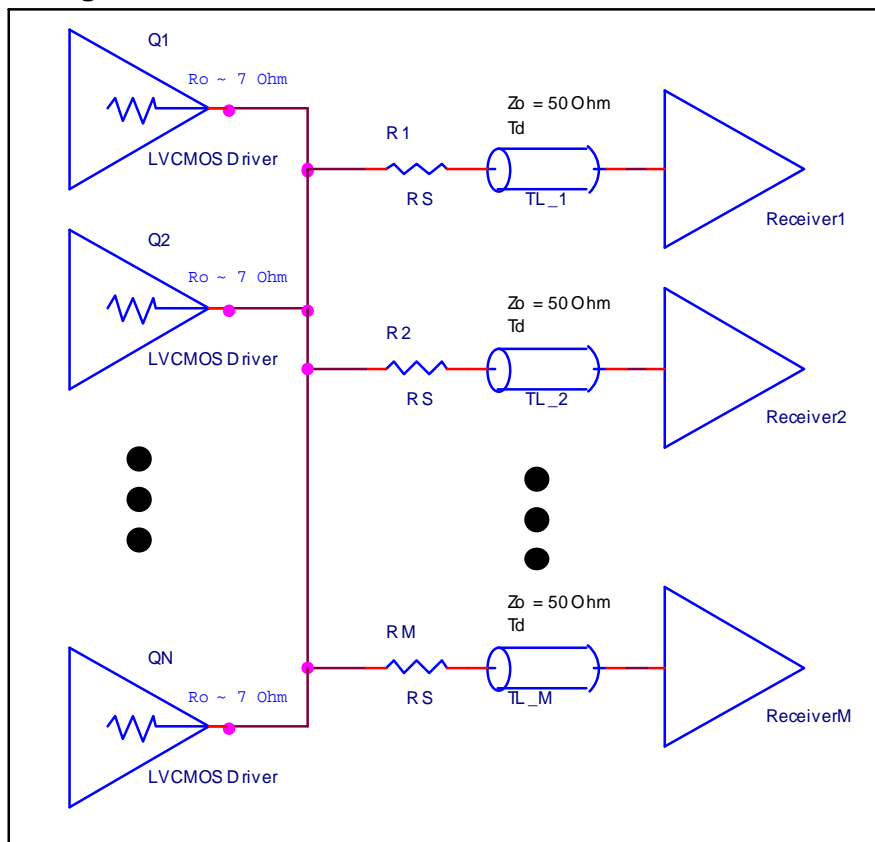

## PC Board Layout with Option of Multiple Termination Scheme

For signal integrity, take the necessary precaution and follow the high-speed digital design rules as much as possible. In most cases, the board design cannot fully comply the high-speed design rules due to constrains on the board environment, e.g. space available, cost, etc. There is always some unknown parameters or interference in the system environment. The signal quality can only be optimized through the experiment; one termination scheme may work better then the other. While capturing a schematic for PC Board layout, if there is space available, it is recommended to provide options to choose different termination schemes. Figure 7 shows an example schematic for a PC board footprint that provides an option of choosing various types of terminations.

**Figure 7. PC Board Layout Provides Footprint to Choose Various Termination Options**

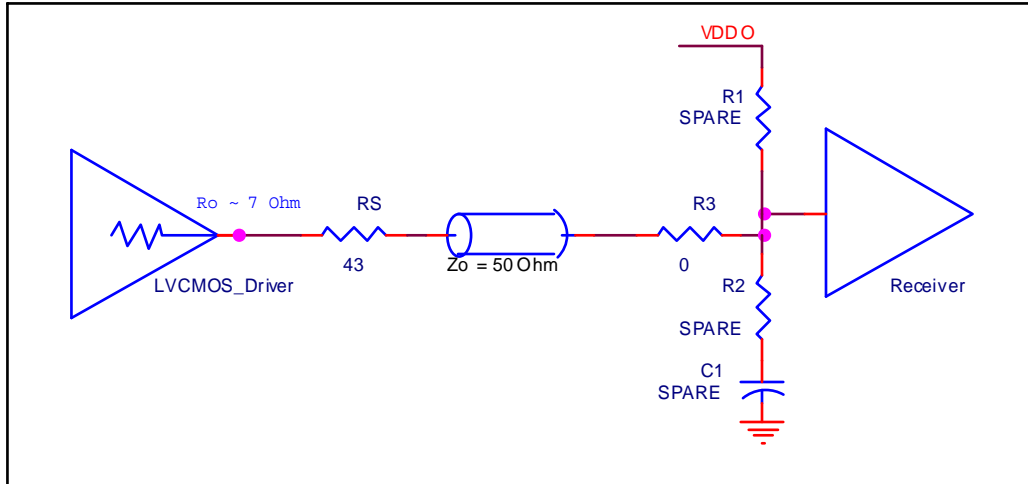

## References

- [1] Kaufer, Steve, Crisafulli, Kellee, Terminating Trace on High-Speed PCBs, Printed Circuit Design, March 1998
- [2] Dr. Johnson, Howard, Dr. Graham, Martin, High-Speed Digital Design, A Handbook of Black Magic, Prentice Hall, 1993



## Notice

1. Descriptions of circuits, software and other related information in this document are provided only to illustrate the operation of semiconductor products and application examples. You are fully responsible for the incorporation or any other use of the circuits, software, and information in the design of your product or system. Renesas Electronics disclaims any and all liability for any losses and damages incurred by you or third parties arising from the use of these circuits, software, or information.
2. Renesas Electronics hereby expressly disclaims any warranties against and liability for infringement or any other claims involving patents, copyrights, or other intellectual property rights of third parties, by or arising from the use of Renesas Electronics products or technical information described in this document, including but not limited to, the product data, drawings, charts, programs, algorithms, and application examples.
3. No license, express, implied or otherwise, is granted hereby under any patents, copyrights or other intellectual property rights of Renesas Electronics or others.
4. You shall not alter, modify, copy, or reverse engineer any Renesas Electronics product, whether in whole or in part. Renesas Electronics disclaims any and all liability for any losses or damages incurred by you or third parties arising from such alteration, modification, copying or reverse engineering.
5. Renesas Electronics products are classified according to the following two quality grades: "Standard" and "High Quality". The intended applications for each Renesas Electronics product depends on the product's quality grade, as indicated below.
  - "Standard": Computers; office equipment; communications equipment; test and measurement equipment; audio and visual equipment; home electronic appliances; machine tools; personal electronic equipment; industrial robots; etc.
  - "High Quality": Transportation equipment (automobiles, trains, ships, etc.); traffic control (traffic lights); large-scale communication equipment; key financial terminal systems; safety control equipment; etc.Unless expressly designated as a high reliability product or a product for harsh environments in a Renesas Electronics data sheet or other Renesas Electronics document, Renesas Electronics products are not intended or authorized for use in products or systems that may pose a direct threat to human life or bodily injury (artificial life support devices or systems; surgical implantations; etc.), or may cause serious property damage (space system; undersea repeaters; nuclear power control systems; aircraft control systems; key plant systems; military equipment; etc.). Renesas Electronics disclaims any and all liability for any damages or losses incurred by you or any third parties arising from the use of any Renesas Electronics product that is inconsistent with any Renesas Electronics data sheet, user's manual or other Renesas Electronics document.
6. When using Renesas Electronics products, refer to the latest product information (data sheets, user's manuals, application notes, "General Notes for Handling and Using Semiconductor Devices" in the reliability handbook, etc.), and ensure that usage conditions are within the ranges specified by Renesas Electronics with respect to maximum ratings, operating power supply voltage range, heat dissipation characteristics, installation, etc. Renesas Electronics disclaims any and all liability for any malfunctions, failure or accident arising out of the use of Renesas Electronics products outside of such specified ranges.
7. Although Renesas Electronics endeavors to improve the quality and reliability of Renesas Electronics products, semiconductor products have specific characteristics, such as the occurrence of failure at a certain rate and malfunctions under certain use conditions. Unless designated as a high reliability product or a product for harsh environments in a Renesas Electronics data sheet or other Renesas Electronics document, Renesas Electronics products are not subject to radiation resistance design. You are responsible for implementing safety measures to guard against the possibility of bodily injury, injury or damage caused by fire, and/or danger to the public in the event of a failure or malfunction of Renesas Electronics products, such as safety design for hardware and software, including but not limited to redundancy, fire control and malfunction prevention, appropriate treatment for aging degradation or any other appropriate measures. Because the evaluation of microcomputer software alone is very difficult and impractical, you are responsible for evaluating the safety of the final products or systems manufactured by you.
8. Please contact a Renesas Electronics sales office for details as to environmental matters such as the environmental compatibility of each Renesas Electronics product. You are responsible for carefully and sufficiently investigating applicable laws and regulations that regulate the inclusion or use of controlled substances, including without limitation, the EU RoHS Directive, and using Renesas Electronics products in compliance with all these applicable laws and regulations. Renesas Electronics disclaims any and all liability for damages or losses occurring as a result of your noncompliance with applicable laws and regulations.
9. Renesas Electronics products and technologies shall not be used for or incorporated into any products or systems whose manufacture, use, or sale is prohibited under any applicable domestic or foreign laws or regulations. You shall comply with any applicable export control laws and regulations promulgated and administered by the governments of any countries asserting jurisdiction over the parties or transactions.
10. It is the responsibility of the buyer or distributor of Renesas Electronics products, or any other party who distributes, disposes of, or otherwise sells or transfers the product to a third party, to notify such third party in advance of the contents and conditions set forth in this document.
11. This document shall not be reprinted, reproduced or duplicated in any form, in whole or in part, without prior written consent of Renesas Electronics.
12. Please contact a Renesas Electronics sales office if you have any questions regarding the information contained in this document or Renesas Electronics products.

(Note1) "Renesas Electronics" as used in this document means Renesas Electronics Corporation and also includes its directly or indirectly controlled subsidiaries.

(Note2) "Renesas Electronics product(s)" means any product developed or manufactured by or for Renesas Electronics.

(Rev.4.0-1 November 2017)

## Corporate Headquarters

TOYOSU FORESIA, 3-2-24 Toyosu,  
Koto-ku, Tokyo 135-0061, Japan  
[www.renesas.com](http://www.renesas.com)

## Contact Information

For further information on a product, technology, the most up-to-date version of a document, or your nearest sales office, please visit:  
[www.renesas.com/contact/](http://www.renesas.com/contact/)

## Trademarks

Renesas and the Renesas logo are trademarks of Renesas Electronics Corporation. All trademarks and registered trademarks are the property of their respective owners.