

Doc 9626



Manual on the Regulation of International Air Transport

Approved by the Secretary General
and published under his authority

Second Edition — 2004

International Civil Aviation Organization

Doc 9626



Manual on the Regulation of International Air Transport

**Approved by the Secretary General
and published under his authority**

Second Edition — 2004

International Civil Aviation Organization

AMENDMENTS

The issue of amendments is announced regularly in the *ICAO Journal* and in the monthly *Supplement to the Catalogue of ICAO Publications and Audio-visual Training Aids*, which holders of this publication should consult. The space below is provided to keep a record of such amendments.

RECORD OF AMENDMENTS AND CORRIGENDA

AMENDMENTS			
No.	Date applicable	Date entered	Entered by

CORRIGENDA			
No.	Date of issue	Date entered	Entered by
1	12/8/05	—	ICAO
2	25/10/05	—	ICAO

FOREWORD

The main purpose of this *Manual on the Regulation of International Air Transport* is to meet an ever-increasing need for a comprehensive and objective source of information about the many facets of this dynamic activity. This need was foreseen by the ICAO Assembly which, by Resolution A24-11, directed the preparation and publication of this manual.

The need for and expected usefulness of this manual is not confined to any particular State or category of States, whether small or large, whether least developed, developing, or having developed economies. Rather, it was prepared to meet the needs of all ICAO Contracting States.

The air transport authorities of these States may well become the most frequent users of this manual. Yet many others in these States may also find it very useful. International air transport evokes considerable interest of many people: those associated with airlines; airports and communities seeking new air services; users of air transport; air carrier labour; aircraft manufacturers; certain international organizations; people involved with aviation financing, tourism development and trade; people in academia and the communications media; and, at times, members of the general public as well. This manual is intended to also meet the needs of and be useful to these broader constituencies within ICAO Contracting States and, in so doing, to increase its value to air transport authorities who interact with such constituencies.

BASIC COMPOSITION OF THE MANUAL

As international air transport developed and became more complex over the past half century, so too has its regulation. Also, much new terminology evolved, often without widely accepted definitions (or with conflicting ones) and sometimes with more than one term applied to the same subject. Thus the approach taken in the preparation of this manual has been to provide clear and adequate explanations and guidance in a well ordered context. Each relatively short chapter is, in effect, a narrative composed largely of a series

of definitions and explanations in a logical order of presentation derived from the topic itself.

Regulation is the giving of authoritative direction to bring about and maintain a desired degree of order. All regulation involves **regulatory process**, various patterns of activity by people interacting to establish and maintain some desired result for the subject or entities being regulated. Similarly, all regulation involves **regulatory structure**, i.e. the organizations or other entities involved and the legal framework (such as licences, regulations and agreements). Finally, all regulation involves **regulatory content**, the particular subjects being regulated (such as market access, pricing and capacity).

The process and structure of international air transport regulation have three distinct venues — national, bilateral and multilateral; therefore, each venue has been assigned a separate part in this manual, i.e. Parts 1, 2, and 3, respectively. Regulatory content topics, which States deal with in all three venues, are in Part 4. General terminology, i.e. that which is common or supplemental to all parts of this manual, forms Part 5. Appendices contain certain reference materials.

FUNCTIONS AND SCOPE OF THE MANUAL

This manual is designed to be “user friendly” and to serve three distinct functions. First, it can be used as a dictionary of international air transport terms: each term listed in the **Index** has a definition or an explanation on the page indicated. On that page, the term is highlighted in bold italic and its definition or explanation is presented in italics.

Second, it can be used as an encyclopedia. Each broad regulatory topic has its own chapter or section of a chapter in the manual, written to compress essential facts into one or a few pages. The **Table of Contents** assists the reader to determine the location of material on broader topics (e.g. the bilateral regulatory process, traffic rights, etc., each of which may involve many related definitions and explanations).

Third, this manual as a whole can be useful as a textbook for academic or other educational and training purposes.

The **scope of the manual** is limited to the economic aspects of international air transport regulation as distinguished from the technical aspects thereof such as those involving navigation, safety and security. Nevertheless, these other areas of regulation are not totally separable from economic regulation and can affect such matters as airline licensing, airport access and the structure of agreed routes. Although air transport regulators sometimes also regulate commercial non-transport operations, such as aerial crop dusting and surveying, as well as non-commercial flying, such as overflight and landing by private, military and State aircraft, both topics are outside the scope of this manual. The term “aviation” is often used incorrectly in lieu of the term “air transport”. While *air transport* is more specific, referring to those aspects related to the carriage by air (usually commercial air transport), *aviation* is generic and includes far more topics such as military, state and private flying, aircraft manufacturing, air navigation, non-commercial transport and specialty air services.

<p style="text-align: center;">WHAT IS NEW IN THE SECOND EDITION</p>

Along with the trend of globalization and liberalization, international air transport has also undergone significant

changes in the last ten years. This second edition has been updated and expanded to take account of the developments in international air transport and its regulation since 1996 when the manual was first published.

This edition includes many new topics (e.g. State aids, competition laws, airline alliances, franchising, aircraft leasing, passenger rights, and privatization of airports), which are emerging issues drawing increasing regulatory attention. A number of new air transport terms and definitions have been added, including many that were non-existent when the first edition was published (e.g. mega-alliance, e-commence, B2B, etc.). Additionally, new websites and e-mail addresses (primarily of air transport-related international organizations and entities) have been added, enabling computer-equipped readers to vastly expand their knowledge base.

The updating of established topics, as well as the addition of new information, adds significantly to the manual’s value as a user-friendly tool for those who are interested in knowing more about the regulatory aspects of international air transport.

This manual both complements and supplements ICAO Doc 9587 — *Policy and Guidance Material on the Economic Regulation of International Air Transport*, which is a compendium of all the formal policies and guidance adopted by ICAO in this field (such as Assembly resolutions, Council decisions, and conclusions and recommendations of air transport conferences).

TABLE OF CONTENTS

	<i>Page</i>		<i>Page</i>
Part 1 — NATIONAL REGULATION		2.2 Structure of Bilateral Regulation 2.2-1	
1.0 Introduction to National Regulation	1.0-1	— Basic Document Types	2.2-1
1.1 Process of National Regulation	1.1-1	— Typical Provisions of Bilateral Air Transport (Services) Agreements	2.2-2
— The Legislative Component	1.1-1	— Types of Bilateral Agreements on Subjects Closely Related to Air Transport	2.2-4
— The Licensing Component	1.1-1	2.3 Key Issues of Bilateral Regulatory Process and Structure 2.3-1	
— The Ad hoc Authorization Component	1.1-2	— Balancing Benefits in a Liberalizing Environment	2.3-1
— Comity and Reciprocity	1.1-3	— Shortcomings of Bilateral Regulatory Structure	2.3-3
1.2 Structure of National Regulation	1.2-1	— Bilateral Relations Involving Groups of States	2.3-4
— The Organizational Component	1.2-1	— Application of Competition Laws to Air Transport	2.3-5
— The Legal Component	1.2-2	— Effects of State Aids and Subsidies	2.3-6
1.3 Key Issues of National Regulatory Process and Structure 1.3-1		2.4 Types of International Air Services Negotiations 2.4-1	
— The Relationship Between Air Transport Regulators and Interested Parties	1.3-1		
— The Optimum Location of the International Air Transport Regulatory Function	1.3-2		
Part 2 — BILATERAL REGULATION		Part 3 — MULTILATERAL REGULATION	
2.0 Introduction to Bilateral Regulation	2.0-1	3.0 Introduction to Multilateral Regulation	3.0-1
— Evolution of the Bilateral Regulation of International Air Services	2.0-1	— A Brief History of the Multilateral Regulation of International Air Transport	3.0-2
2.1 Process of Bilateral Regulation	2.1-1	3.1 Process of Multilateral Regulation	3.1-1
— Initiation of and Preparation for a Formal Bilateral Consultation	2.1-1	— Formal Multilateral Meetings	3.1-1
— Consultations and Negotiations: Types of Meetings and Documents	2.1-4	— Process within Formal International Organizations	3.1-3
— Consultations and Negotiations: Strategic and Tactical Considerations	2.1-5	— The Multilateral Treaty Process	3.1-3
— Conclusion, Implementation, Management, Dispute Resolution, Amendment and (Exceptionally) Termination of an Agreement	2.1-7	3.2 Structure of Multilateral Regulation	3.2-1
		— Basic Elements of the Organizational Component	3.2-1
		— Basic Terminology of the Legal Component	3.2-2

	<i>Page</i>		<i>Page</i>
— The Chicago Conference Documents	3.2-3	— Main Components of the IATA Organizational Structure	3.8-1
— The Warsaw System and the Montreal Convention of 1999	3.2-4	— The IATA Traffic Conference Structure	3.8-1
— Other Air Law Instruments	3.2-5	— Tariff Coordination Process	3.8-2
— Regional Multilateral Agreements	3.2-5	— Trade Association Activities	3.8-3
3.3 Key Issues of Multilateral Regulatory Process and Structure	3.3-1	3.9 Non-governmental Organizations	3.9-1
— Why the Multilateral Approach?	3.3-1	— Air Carrier Organizations	3.9-1
— Possible Processes in the Quest for a New Multilateralism	3.3-2	— Other Aviation Organizations	3.9-2
— The Likely Generic Structural Elements of a New Multilateral Air Transport Agreement	3.3-3	— Other Organizations Interested in Air Transport	3.9-3
— The General Agreement on Trade in Services (GATS) and its Air Transport Annex	3.3-4		
3.4 International Civil Aviation Organization (ICAO)	3.4-1		
— Policy Development Bodies	3.4-1		
— Air Transport Bureau	3.4-3		
— ICAO Policy, Guidance and Information	3.4-4		
3.5 Worldwide Intergovernmental Organizations	3.5-1		
— Organs of the United Nations	3.5-1		
— Specialized Agencies of the United Nations	3.5-2		
— Other Worldwide Intergovernmental Organizations	3.5-2		
3.6 Regional Intergovernmental Civil Aviation Organizations	3.6-1		
— Africa	3.6-1		
— Europe	3.6-1		
— Latin America and the Caribbean	3.6-2		
— Middle East	3.6-2		
3.7 Regional and Trans-regional Intergovernmental Organizations and Trade Areas	3.7-1		
— Regional Intergovernmental Organizations	3.7-1		
— Formal Trans-regional Groups	3.7-6		
— Informal Trans-regional Groups	3.7-6		
3.8 International Air Transport Association (IATA)	3.8-1		
		Part 4 — REGULATORY CONTENT	
		4.0 Introduction to Regulatory Content	4.0-1
		4.1 Basic Market Access	4.1-1
		— Route Rights	4.1-2
		— Operational Rights	4.1-5
		— Traffic Rights	4.1-8
		— Market Access as Affected by the So-called “Sixth Freedom”	4.1-12
		4.2 Air Carrier Capacity	4.2-1
		— Capacity Regulation by Governments	4.2-1
		— Capacity as Viewed by Air Carriers	4.2-3
		4.3 Air Carrier Tariffs	4.3-1
		— Why States Regulate Tariffs	4.3-1
		— Definition of Tariff	4.3-1
		— Types and Characteristics of Tariffs	4.3-2
		— Methods for Regulating Tariffs	4.3-6
		— Key Tariff Issues	4.3-8
		4.4 Air Carrier Ownership	4.4-1
		— The Discretionary Criteria	4.4-1
		— Use of the Criteria	4.4-1
		— Some Exceptions	4.4-2
		— Foreign Investment in Air Carriers	4.4-3
		— Key Issues	4.4-3
		4.5 Air Cargo	4.5-1
		— Distinct Features of Air Cargo	4.5-1
		— Regulation of Air Cargo	4.5-1
		4.6 Non-scheduled Air Services	4.6-1

	<i>Page</i>		<i>Page</i>
— Characteristics of Non-scheduled Air Services	4.6-1	4.10 Airport-related Matters	4.10-1
— Kinds of International Non-scheduled Air Services	4.6-1	— Ground Handling	4.10-1
— Regulation of Non-scheduled Air Services	4.6-3	— Slot Allocation	4.10-2
		— Privatization of Airports	4.10-2
4.7 Airline Commercial Activities	4.7-1		
— Currency Conversion and Remittance of Earnings	4.7-1	Part 5 — GENERAL TERMINOLOGY	
— Employment of Non-national Personnel	4.7-2	5.0 Introduction to General Terminology	5.0-1
— Sale and Marketing of International Air Transport	4.7-2	5.1 Air Carriers	5.1-1
— Airline Product Distribution and Electronic Commerce	4.7-3	5.2 Aircraft	5.2-1
— Aircraft Leasing	4.7-5	5.3 Air Services	5.3-1
4.8 Airline Cooperative Activities	4.8-1	5.4 Airports	5.4-1
— Airline Alliances	4.8-1		
— Airline Codesharing	4.8-2	APPENDICES	
— Airline Franchising	4.8-4	1. Formats for Tariff Filings	A1-1
4.9 Airline Passengers	4.9-1	2. IATA Currency Conversion System	A2-1
— Passenger Rights	4.9-1	3. Prorating	A3-1
— Airline’s Condition of Contract/Carriage	4.9-4	4. Guidance Material for Users of Air Transport	A4-1
— Unruly or Disruptive Passengers	4.9-5		
— Improperly Documented Passengers	4.9-6	INDEX	

Part 1

NATIONAL REGULATION

Chapter 1.0

INTRODUCTION TO NATIONAL REGULATION

National regulation of air transport is regulation undertaken by a State within its territory in its exercise of sovereignty over that territory and the airspace above it. Thus national regulation extends to both domestic and international air services and to both national and foreign air carriers. The national regulation of international air services must take into account the State's international obligations pursuant to bilateral and multilateral agreements and arrangements and should give due regard to the actions and concerns of other States.

The particular aims of national regulation in the field of international air transport vary from State to State and are influenced by national economic policies, territorial size and location, the degree of national development, domestic and international politics, etc. Those aims are, however, likely to include all or several of the following:

- to provide for the transport requirements of foreign commerce;
- to promote particular service sectors (such as tourism);
- to provide employment;
- to earn foreign exchange;
- to meet the needs of the postal system;
- to create the conditions for a viable, healthy air transport sector;

- to aid in national development;
- to serve national defence; and
- to meet disaster assistance needs.

The process of national regulation involves three distinct kinds of actions — legislating; licensing; and determining ad hoc authorizations. Chapter 1.1 describes these three components and explains the concepts of comity and reciprocity used in the national regulation of international air services.

The structure of national regulation has an organizational component made up of governmental bodies and a legal component embodied in national laws, policies, rules and regulations with respect to air transport services. Chapter 1.2 explains the organizational component by identifying the primary as well as other governmental bodies that are involved in air transport regulation and explains the legal component by describing its major elements.

Chapter 1.3 examines certain key issues of process and structure in the national regulation of international air transport.

The topics which make up the subject matter or content of regulation, such as traffic rights, tariffs and capacity, are presented in Part 4 of the manual.

Chapter 1.1

PROCESS OF NATIONAL REGULATION

The **process of national regulation** of air transport services has three basic components:

- *legislative (i.e. the making of laws, policies, rules and regulations);*
- *licensing (i.e. the granting, conditioning, denying or withholding of permission to conduct air transport services on a continuous or long-term basis); and*
- *ad hoc authorization (i.e. the granting, conditioning, denying or withholding of permission for individual tariffs, flights, etc.);*

each of which are complemented by enforcement actions taken if and when required.

These three elements are described in the next three sections. The last section discusses the concepts of comity and reciprocity employed in the national regulation of international air services.

THE LEGISLATIVE COMPONENT

The legislative component of the process of national regulation has three elements: law-making, policy-making and the writing of rules and regulations. Each element of the process is likely to differ from the others and to vary from State to State according to its particular legislative system, governmental structure and customary practices. In general, however, the law-making element tends to come into use least often and be employed for establishing laws and fundamental policies. Once enacted, such laws are usually changed only when issues of far-reaching significance are involved. The details of implementation are typically left to the rule-making process.

In contrast to the law-making element, the process involved in the writing or amending of rules and regulations tends to be used more frequently, to be more rapid and to be initiated and completed by air transport authorities with or without public comment. Rules and regulations are likely to be more detailed and flexible than laws and to provide possibilities for making exceptions or granting exemptions.

The policy-making element is perhaps the most flexible and most likely to vary from State to State and even within a given State. This is because a State may choose to express policy within a law or decree, in a rule or regulation, in a separate policy statement, or by other means. (A State may also establish some policies, usually more detailed and specific, in certain licensing or ad hoc approval determinations which can serve as precedents for future similar situations.)

THE LICENSING COMPONENT

The licensing component of the process of national regulation involves the consideration of and action upon applications received from national and foreign air carriers for authority to provide commercial air services on a continuous basis and for extended periods of time (for example, scheduled services on a specified route or routes). In addition to licensing national and foreign air carriers, air transport authorities may also engage in licensing certain intermediaries in air transportation such as tour organizers, freight forwarders or travel agents.

The regulatory authority typically makes its licensing decision on the basis of an evaluation of the pertinent facts in the light of established legal and policy criteria. The authorization issued often takes the form of a **licence** or **permit**, *i.e. a formal statement of permission from a constituted authority to carry out some service or business activity.* In

some States, a licence is issued to a national carrier and a permit to a foreign applicant, while in some others, a licence is granted for scheduled operations and a permit is given for charter flights. A licence or permit may be valid indefinitely or for a specified period of time only.

The criteria used in licensing a national carrier vary from State to State but generally include:

- a national ownership and control requirement;
- proof of the applicant carrier's fitness, i.e. its financial health, its willingness to provide the proposed services and its ability to meet established operational and safety standards; and
- a finding that granting the authority will be in the public interest.

In addition, in some cases, criteria agreed upon at the international level may be included.

The scope of the authority granted to a national carrier may cover domestic or international air services, or both. When the requested authority involves operation of an international air service, consideration is also given to the rights available to the licensing State under pertinent air transport agreement(s). In situations where more than one air carrier applies for a route which only one such carrier may serve, a selection process is required. Such a selection process may involve analysis and evaluation of the proposals or intended services of each contender and may or may not be public.

In considering the grant of a permit or licence to a foreign air carrier, air transport authorities usually rely on decisional criteria established in the relevant air transport agreement as well as national laws or regulations. Such criteria are likely to include the requirement that substantial ownership and effective control of the foreign air carrier be vested in the designating State or its nationals and the willingness and the ability of the applicant to comply with relevant national laws and regulations.

The requested authority may be approved in whole or in part, conditioned, denied or withheld on the grounds established in the applicable national laws and regulations and the relevant air transport agreement. One condition, for example, could be a requirement that the carrier obtain a certain amount and type of liability insurance.

**THE AD HOC AUTHORIZATION
COMPONENT**

Unlike the licensing component which deals with relatively general and longer-term authorizations for air services, the ad hoc authorization component of the process of national regulation primarily involves making day-to-day decisions regarding specific matters, such as permitting a single flight or a series of non-scheduled flights or approving or disapproving a particular tariff or schedule filing. This process could have some or all of the following phases:

- a fact-finding or information-gathering phase (often the initial responsibility of the applicant) which includes assembly of the basic elements necessary to reach a decision, i.e. an adequate description of the approval being sought; the relevant international rights and obligations; the applicable national laws, policy, rules and regulations; relevant precedents; and views of interested parties;
- an analysis phase which includes examination of the gathered information and the production of options for the decision-maker with a rationale for each, including the advantages and disadvantages of each option;
- a decision phase which includes weighing the facts and options presented and may also include, in significant cases, taking into account the views received from other regulatory officials or other governmental elements as to the course of action to be taken; and
- an optional review/reconsideration phase which may take place either within the governmental entity that undertook the previous three phases, or elsewhere in the government; may be done publicly or in private; and may, in some instances, also involve judicial review.

This process may be quite brief (for example, when a regulator considers a single non-controversial fare or rate) or very long if it concerns a complex or controversial matter (for example, a commercial arrangement involving codesharing).

COMITY AND RECIPROCITY

Of particular importance in the national regulation of international air services are the concepts of comity and reciprocity, especially where a commercial activity is not covered by a specific provision in an air transport agreement. *Comity is due deference given by the authorities of one State to the official acts of another State.* In regulatory practice, comity sometimes underlies the unilateral grant of a right or benefit to a foreign airline with no necessary expectation of the same treatment by that airline's State in similar circumstances. For example, a State may, on the basis of comity, approve reduced fares or rates which a foreign government has ordered its national airline to provide to its officials.

In contrast, *reciprocity is the granting of a right or benefit by a State to a foreign entity such as an air carrier when it has no international obligation to do so, on the condition that the same treatment will be accorded to its comparable entity (entities) by the home State of that foreign entity.* For example, a State might approve a non-scheduled flight or flights by a foreign airline if that foreign

airline's State has in the past approved, or promises in the future to approve, a non-scheduled flight or flights for the first State's airline(s).

Reciprocity may be narrowly or broadly defined. For example, in relation to non-scheduled air services, reciprocity in a narrow context might require approval only of a specific type and number of non-scheduled flights, for example, four non-scheduled flights to carry livestock. A broader concept of reciprocity would make no such distinction as to the type or number of non-scheduled flights but might require merely that all non-scheduled flights in a general category, for example, those to/from a third country, be approved.

Comity and reciprocity are often employed together. One such case arises when an air transport agreement has been terminated and no new agreement or arrangement has been reached to replace it. In such a situation, when authorizing scheduled services, a State might, as a matter of comity, approve services by a foreign airline or airlines of its former bilateral partner which involve routes not served by its national airline(s) but insist on reciprocity with respect to the capacity operated by such foreign airlines on routes also served by its national airline(s).

Chapter 1.2

STRUCTURE OF NATIONAL REGULATION

The *structure of national regulation of international air transport* has:

- *an organizational component consisting of a governmental entity or entities which function as the State's air transport authorities as well as certain other non-aviation governmental bodies, the actions of which affect international air transport; and*
- *a legal component embodied in the pertinent national laws, rules and regulations, judicial and administrative decisions, licences and/or permits and declared policies as well as relevant international agreements to which the State is a party.*

The next two sections of this chapter explain the organizational and legal components, respectively.

THE ORGANIZATIONAL COMPONENT

The primary element of the organizational component of the structure of national regulation is that of the State's air transport authorities. National *air transport authorities* (also called *aeronautical or civil aviation authorities*) are the governmental entity or entities, however titled, that are directly responsible for the regulation of all aspects of civil air transport, technical (i.e. air navigation and aviation safety) and economic (i.e. the commercial aspects of air transport). The functions performed by such entity or entities with respect to the economic regulation of international air transport are likely to include:

- the development of economic policies and strategies with respect to air transport;

- the formulation of specific rules and regulations to implement basic aviation law and to further national policy goals and objectives;
- the issuance (or denial or withholding) of national and foreign air carrier licences and permits;
- the authorization of air carrier schedules, tariffs, etc.;
- the coordination of air transport policy and regulation with other governmental entities such as those responsible for trade and commerce, tourism, financial controls, taxation, national development, etc.; and
- the conduct of bilateral and multilateral international relations with respect to air transport.

These functions (other than that of international aviation relations where the lead role may be taken by the ministry or department responsible for foreign affairs) are generally located in a single national entity such as a ministry of transport or a department of civil aviation. The functions may, however, be divided among two or more entities, for example, with one responsible for technical regulation and another responsible for economic regulation. In some States the primary air transport economic regulatory entity may be a quasi-judicial body which is relatively independent and which performs some or all of the above functions (e.g. a board or commission).

The effective operation of any national organizational structure requires skilled people. The primary skills needed by air transport regulators include those essential for:

- the collection and presentation of traffic, financial and other air service statistics;

- the analysis of relevant quantitative and qualitative data such as that relating to tariffs and air transport agreements;
 - the forecasting of future traffic in order to meet infrastructure requirements, a proposed establishment of a new route or routes, etc.;
 - decision making, particularly in licensing and other authorization matters;
 - effective writing of decisions, agreements, policy statements, etc.;
 - foreign relations, both with foreign air carriers and with foreign governments as part of air service consultations;
 - multinational affairs, particularly relationships with worldwide international organizations such as the International Civil Aviation Organization and the International Air Transport Association, as well as with regional and trans-regional organizations;
 - legal matters regarding the interpretation of laws and agreements, the licensing process, etc.;
 - administration, including matters of finance, personnel, information storage and retrieval, etc.; and
 - public relations and coordination with other governmental entities.
- financial controls, i.e. on currency conversion and remittance, including the earnings of foreign airlines;
 - taxation, i.e. of air carriers' earnings, traffic, fuel, supplies, etc.;
 - competition maintenance, which can involve the prohibition of certain activities by both national and foreign air carriers;
 - environmental controls, for example, curfews at airports where aircraft noise is a concern;
 - tourism development, i.e. to promote air travel by foreigners to the State; and
 - labour, whose actions can affect the terms and conditions of employment of air carrier staff, both of national and, in some instances, of foreign companies.

In a small air transport regulatory entity, the skills to perform the above tasks could be possessed collectively and in varying degrees by as few as one or two persons who may rely on a larger body, such as a governmental department or ministry, for certain services (such as legal, administrative, and public relations).

The other element of the organizational component of the structure of national regulation, i.e. the non-aviation governmental entities, the actions of which affect international air transport, includes (but is not necessarily limited to) those national authorities responsible for:

- customs controls, i.e. on the importation (and sometimes the exportation) of goods;
- immigration controls, i.e. on the entry and departure of international airline passengers;
- public health standards (including inspection and quarantine which affect both passengers and goods);

Air carriers can also expect a certain degree of regulation by local authorities under laws and rules applied to all commercial activities, for example, regarding the safety of premises on or off airports used for sales offices, warehouses, etc. Certain other actions taken by a government below the national level in a federal State can also affect international air services. One example is the imposition of local taxes on fuel and supplies used in international air services. Another is the levy of income taxes on the earnings of international air services by foreign air carriers. Such actions can be very controversial and may or may not be affected by international agreements on taxation.

THE LEGAL COMPONENT

The legal component of the structure of national regulation of international air transport is embodied in each State's:

- basic aviation laws, which typically govern other regulatory actions such as rule-making, licensing, and enforcement, as well as provide the legal foundation for the organizational structure and process employed;
- pertinent national laws which affect particular regulatory actions (for example, a law requiring that due process be followed in any licensing matter);

- international agreements, multilateral and bilateral, to which the State is a party, to the extent that the international rights and/or obligations they contain must be taken into account in the basic process of national regulation of international air services;
- policy statements or directives in various forms (for example, as in a *White Paper*, i.e. an authoritative report which provides information about the policies, positions and intended course of action of the issuing party), which set forth goals, objectives, approaches or general or specific guidelines for international air transport regulation;
- rules and/or regulations which implement its basic aviation laws by specifying particular requirements which are imposed on air carriers or others (for example, to provide traffic data, information on the rights of air transport users, filing schedules and tariffs, etc.);
- judicial decisions on specific air transport matters (for example, a court or competition authority ruling in a dispute between companies on computer reservation system issues);
- licences and/or permits which authorize the ongoing operation of international air services by national and foreign air carriers, in particular to the extent these permissions constitute or contain precedents which may influence or determine future licensing actions;
- ad hoc decisions (for example, approval of a commercial arrangement for cooperation between two airlines) which may become precedents for future regulatory action in similar situations; and
- ad hoc authorizations (for example, approval of a schedule or a tariff) which remain a part of the legal component while they are in effect.

Transparency (the making known of governmental legal decisions to the public) is often carried out by publication in a *gazette*, *register*, or *journal*, i.e. a periodic (often daily) official government publication which sets out laws, rules, regulations and decisions taken by the government during the period of time covered by the particular issue (except for minor ad hoc decisions), including those pertaining to civil aviation.

Because of differences between each State's governmental structure, legal system, culture and customary practices, national rules and/or regulations tend to differ in relation to:

- terminology (for example, an authorization for ongoing air services by a foreign air carrier may be called a licence by one State and a permit by another);
- subject matter (for example, some States have rules and/or regulations for computer reservation systems but many do not);
- the treatment of subject matter (for example, most States have distinctive policies and practices for the authorization, withholding, denial or conditioning of international charter flights);
- format (for example, there is no standardization among States in writing their national regulations); and
- language or languages used.

The topics covered by national rules and regulations affecting the commercial aspects of air transport are likely to include, *inter alia*:

- the provision of air carrier (and airport) traffic and financial and other data as may be required including definitions, deadlines, filing formats, etc.;
- the organization, pricing, authorization and operation of charter flights and other non-scheduled air services;
- the filing of tariffs for monitoring or approval; (Formats developed by ICAO which may be used by national air transport authorities for the filing of airline passenger tariffs can be found in Appendix 2 of the manual.)
- the application for and processing of licences, permits and ad hoc authorizations for air services; and
- the protection of users, such as in rules requiring compensation for denied boarding of aircraft.

In some States the governmental requirements on many of the above matters may be set forth in decisions or orders issued by the air transport authorities.

Chapter 1.3

KEY ISSUES OF NATIONAL REGULATORY PROCESS AND STRUCTURE

This chapter discusses two of the key issues of the process and structure of national regulation of international air transport: first, how international air transport regulators should deal with interested governmental or non-governmental parties and their different input in the regulatory process and, second, where the international air transport regulatory function can best be located in the governmental structure.

THE RELATIONSHIP BETWEEN AIR TRANSPORT REGULATORS AND INTERESTED PARTIES

In the national regulatory process (i.e. legislating, policy-making, licensing and ad hoc authorization), international air transport regulators are likely to receive input from at least some members of the following three types of interested parties:

- governmental entities which have not necessarily been assigned the international air transport regulatory function but have a direct interest in the outcome of that function and which may at times seek to control or shape particular policies or decisions; these entities include departments responsible for foreign affairs, tourism, trade and commerce, and transport and communications;
- non-aviation governmental entities whose actions may intentionally or otherwise impact upon air transport regulation; these include departments responsible for customs, immigration, public health, taxation, finance, currency control, the environment, competition regulation and, in some cases, sub-

national (e.g. provincial/state) authorities or supra-national authorities such as those of a grouping of States; and

- interested non-governmental parties which may seek to influence policy or decision making; these include airlines, airports, consumers, communities, business or tourism interest groups, air carrier labour and possibly aircraft manufacturers.

Each of these parties has its own interests in and emphasis to place on the formulation of policies, decisions, rules and regulations vis-à-vis international air transport. National regulation is also influenced by the policies and actions of other States. The issue faced by the international air transport regulators is how to deal with these parties and their various, often conflicting, input.

As far as the parties in the first group (aviation-related governmental entities) are concerned, the decision on which entity to consult and how much weight to give to its views may depend largely on their respective primary regulatory functions relative to that of international air transport regulation, taking into account the priority accorded to foreign policy goals, tourism, national development considerations, trade and commerce interests, and any government requirement for formal or informal intergovernmental coordination.

Of the parties in the second group (non-aviation governmental entities), the customs, immigration, public health, finance and taxation departments are traditionally the ones whose actions affect certain aspects of international air transport regulation. In recent years, air transport activities have become increasingly affected by regulatory actions taken by other government bodies, particularly those dealing with trade, competition law,

taxation and the environment. The primary function/responsibility of these bodies includes regulatory actions outside the aviation field and therefore their policy objectives may not be the same as those of the air transport authorities. Consequently, their regulatory actions can have a significant impact on the operating environment of the air transport industry. The overlapping of certain regulatory functions and responsibilities may also give rise to potential conflicts between governmental entities. In such situations, national air transport regulators may need to strengthen coordination with these other government bodies to harmonize their international air transport regulations, policies and decisions.

Among the parties in the third group (interested non-governmental parties), international air transport regulators traditionally consult national airline(s) on most matters relating to international air services and give considerable weight to their views since the regulation of these matters directly affects the livelihood of the airline(s). However, as the air transport industry matures in many countries, other parties are likely to become interested in influencing the process, increasingly seeking to have their views taken into account in decision making because international air transport regulation can have a direct or indirect economic impact on them; for example:

- airport development depends on revenues earned from air traffic;
- passengers and shippers are the direct users and revenue generators of air services;
- communities see an important role for air services in local economic development;
- local commerce or tourism benefit from increased air transport services;
- aircraft manufacturers depend a great deal on aircraft orders from airlines which may be affected by regulatory decisions;
- airline labour's well-being is affected by the financial health of the airlines; and
- other modes of transport (such as road and rail) might have concerns about competition from air services.

Should air transport regulators change their traditional attitude? Should they broaden the basis for their policies

and decisions? On the one hand, giving greater weight to the interests of above parties may help to formulate more balanced air transport policies and decisions. On the other hand, consultation with more parties may lead to a longer, more complicated process, possibly requiring more staff to handle the increased workload.

The decision on which party to consult may depend on the subject matter. A major policy decision such as the making of the government's basic international air transport policy may involve consultation with all three types of parties. For licensing decisions, consideration may be given primarily to input from those parties directly involved; for example, input on the safety record of the airline applicant from the office for aviation technical regulation and/or comments on possible effects on competition in the market from airline(s) which may be affected by the grant of the licence. In making specific authorizations such as approving schedules, tariffs or charter flights, the decision-making process may involve only those parties concerned with the particular matter in question; for example, an air navigation office or airport authority for input on the availability of take-off and landing slots, and competing airlines for capacity or tariff matters.

Certain air transport regulatory actions taken by foreign governments may also influence national air transport policy and decision making; for example, the international air policy or competition law decisions of another country which is a major market for the national air carrier(s). In some cases, national air transport regulators will need to take into account regulations of a supranational authority constituted by a group or union of States to which the State is a party; for example, the requirement to apply the internationally agreed criteria in licensing a national air carrier for international air services.

**THE OPTIMUM LOCATION OF THE
INTERNATIONAL AIR TRANSPORT
REGULATORY FUNCTION**

Each State is in the best position to determine the optimum location for its international air transport regulatory function within its national governmental structure, taking into account its general structural division of responsibilities, the degree of its national development, its economic policy, the state of its air transport industry and the available human and physical resources. States have found a variety

of such locations and from time to time individual States re-evaluate and change their optimum locations for air transport matters.

When the optimum location of the international air transport regulatory function becomes an issue, the basic consideration is whether the entity (of whatever size) performing such a function should be:

- independent of or under the control of an entity that regulates the technical aspects of civil aviation;
- separate from or a part of the domestic air transport regulatory entity;
- part of a larger government organization (e.g. a department of transport or a ministry of tourism);
- a quasi-judicial body; or
- an autonomous or semi-autonomous authority.

In many States, air transport regulation, both economic and technical, is carried out through a single governmental entity, under the overall control of a minister or director general of civil aviation. The advantages of having a single entity handling all aspects of civil aviation regulation include consistent, coherent and efficient discharge of functions; closer coordination between aviation economic and technical regulation, both national and international; and possibly more responsiveness to the needs of the air transport industry. One weakness may be that too much emphasis on promotion of civil aviation could result in insufficient attention being paid to its role in serving broader national interests.

In States where domestic air transport activity is limited, the office responsible for international regulation may have reasons to incorporate any relevant domestic air service regulations into its own regulations. On the other hand, the placement of international regulation in an office in charge of domestic regulation could result in lessened responsiveness to distinctly international matters.

As regards whether the international air transport regulatory function should be placed within some other governmental entities having different or broader responsibilities than air transport, each possibility has its distinct strengths and weaknesses.

A department or ministry of transport or communications may argue that it should be responsible for

international air transport regulation because a single governmental body which regulates all modes of transportation (i.e. road, water, railways, air, etc.) could better coordinate the different forms of transport to build an integrated national transport network. The weakness of this argument may be that the activities of other modes of transport are mostly domestic, that they have few characteristics in common and that interface between these modes is relatively rare in cases other than that of intermodal freight movements.

A department or ministry of tourism may also see itself better placed to assume the functions of international air transport regulation, particularly in States where foreign tourism is a major component of the national economy. The rationale is likely to be that the two industries are closely related and largely interdependent because air service may be the primary means to bring in foreign tourists; thus the benefits of both could be maximized by close coordination under the same governmental entity. However, decisions made primarily on tourism promotion considerations may be perceived as compromising the interests of the national airline(s) (for example, by permitting unreciprocated market access to the State by foreign airlines) and could also have implications for air freight and mail services.

A department or ministry of trade may find logic in having international air transport regulation under its responsibility because international air services are an important part of international commerce (particularly in a State where air services are largely or totally international). Furthermore, because air transport has come to be one of the sectors in trade in services, putting it under a trade department's control may help to achieve a better overall trade balance. However, there is the possibility that air transport interests may be subordinated to other economic interests and may even be "traded-off" and that air transport regulations produced under influence of trade policies may create potential regulatory conflicts with other States where the airline industry is still being operated largely under a different regulatory regime than that of trade.

A department or ministry responsible for foreign affairs may believe that it should have some or even a predominant role in international air transport regulation because of the international relations aspects and its expertise in dealing with other countries. It may assert that bilateral air service agreements and their negotiation are a part of broader international relations and thus involve foreign policy consideration or coordination. However, the foreign affairs officials may not be familiar with the specificities of civil aviation and lack the necessary knowledge of the

technical or economic aspects of air transport operations and regulation. They could even subordinate air transport to other foreign policy goals.

A department or ministry of defence may (rarely) claim a role in civil air transport regulation based on the strategic military importance of the national airline(s) and the aviation experience found in the State's air force. Yet, the needs of strategic defence and international air transport are unlikely to coincide and the commercial experience and expertise required in air transport regulation are not normally found in military organizations.

Some States, typically where the air transport industry is well developed with multiple air carriers of different ownership and size and in different stages of development (e.g. well-developed incumbents, new entrants, etc.), may find it preferable to establish a quasi-judicial body to perform certain or all air transport regulatory functions, for example, to license air carriers and award route authority. The main reason for this is to achieve fairness in regulation and avoid decisions being made based purely on political rationales. A weakness may be that such an independent entity may not take full account of government policies which are different and/or envision a different role for air transport.

Some other States may find it desirable to set up an autonomous or semi-autonomous civil aviation authority, a partially or fully independent, perhaps even quasi-private, entity entrusted by the State with some or many of civil aviation functions. This has the attraction of possibly greater

operating efficiency and flexibility and an ability to be at least partially supported by funds generated by its services and facilities (as well as non-aviation revenues) rather than full government funding. Such an authority, with more control of its human and financial resources, could function under government policy guidance with due regard to economic factors and thus may achieve better results both in air transport regulation and in the financial viability of its operation. The major disadvantage is a structural inability (inherent in autonomy from its government) to perform the functions required of that government under international treaties and agreements.

Along with the trend of liberalization and privatization, recent years have seen a growing number of States establish autonomous authorities, particularly in the provision of airports and air navigation services. Experience gained worldwide indicates that where airports and air navigation services have been operated by autonomous entities (commercialized or even privatized), their overall financial situation and managerial efficiency tend to improve. ICAO therefore recommends that where this is in the best interest of providers and users, States consider establishing such autonomous entities (*ICAO's Policies on Charges for Airports and Air Navigation Services* (Doc 9082)). ICAO has also developed guidance material on the establishment of such entities (e.g. their organizational structures, scope and responsibilities), which may be found in the *Airport Economics Manual* (Doc 9562), the *Manual on Air Navigation Services Economics* (Doc 9161) and *Privatization in the Provision of Airports and Air Navigation Services* (Cir 284).

Part 2

BILATERAL REGULATION

Chapter 2.0

INTRODUCTION TO BILATERAL REGULATION

***Bilateral regulation** is regulation undertaken jointly by two parties, most typically by two States, although one or both parties might also be a group of States, a **supra-State** (i.e. a community or other union of States acting as a single body under authority granted to it by its member States), a regional governmental body or even two airlines (for example, in the determination of capacity or prices).*

The goal of bilateral regulation in the international air transport field is typically the conclusion, implementation or continuance of some kind of intergovernmental agreement or understanding concerning air services between the territories of the two parties.

A brief history of the evolution of the bilateral regulation of international air services follows this introduction.

A significant amount of intergovernmental bilateral regulatory activity involves formal consultation undertaken to conclude, interpret, expand or amend, or resolve a dispute under an intergovernmental agreement, arrangement or understanding concerning international air services. The many steps and aspects of this process are identified and discussed in Chapter 2.1 of the manual.

Unlike national and multilateral regulation, the bilateral regulation of international air transport has no organizational structure. It does have an extensive legal regulatory structure composed of several thousand bilateral agreements and understandings. Chapter 2.2 explains this structure by identifying the basic document types used in bilateral regulation, by defining and describing the typical provisions of bilateral air transport agreements and by identifying several types of bilateral agreements on subjects closely related to air transport.

The bilateral regulation of international air transport has not evolved without challenges and persistent issues. Chapter 2.3 sets forth certain key issues of process or structure in bilateral regulation.

In recent years, States have chosen to relate to one another in new and different ways, especially with the formation of economic communities or other unions of States. As its definition indicates, bilateral regulation can now, and could increasingly in the future, involve States in various relations other than simply one-to-one. Chapter 2.4 presents a typology of existing and possible future air services negotiations.

The content subjects of bilateral regulation, for example, traffic rights, capacity, pricing, etc., are presented in Part 4 of the manual.

EVOLUTION OF THE BILATERAL REGULATION OF INTERNATIONAL AIR SERVICES

The bilateral regulation of international air services evolved over many decades. Although international air transport services were first developed in the 1920s, few bilateral intergovernmental agreements were concluded in those early decades due to the small volume of international air transport activities and then to the virtual cessation of many commercial flights during the 1939–1945 (World War II) period.

Bilateral agreements now in force, which constitute the largest volume of international air transport regulatory documents, largely date from after the 1944 International Civil Aviation Conference held in Chicago (see Chapter 3.0). This extensive use by States of bilateral agreements to regulate international air transport is a consequence of agreement in the Convention on International Civil Aviation (hereinafter referred to as the Chicago Convention) on the principle of national sovereignty over territorial airspace (Article 1), agreement on the requirement for special

permission or other authorization to operate scheduled international air services over or into the territory of a Contracting State (Article 6), and the lack of success of efforts to establish a multilateral regulatory regime for the commercial aspects of international air transport. Thus bilateral negotiations and the agreements they produced emerged as the preferred method for States to exchange commercial rights for air services and to agree on ways of regulating capacity, tariffs and other matters.

Among the post-1944 bilateral air agreements, the most significant and influential to the development of international air transport regulation was the 1946 agreement between the United Kingdom and the United States (now known as the Bermuda I Agreement). This agreement was the result of a compromise between the two broad approaches to the regulation of international air transport services that had emerged at the Chicago Conference and been left unresolved. At one extreme it was held that there should be no regulation of capacity or tariffs nor narrow definitions of routes. The opposite view was that capacity should be predetermined, tariffs regulated by an international agency and routes specified. Under the compromise agreement, tariffs were to be established by the airlines through the International Air Transport Association (IATA), subject to the approval of both parties. Capacity was to be determined by airlines subject to certain agreed principles and to possible joint review by the parties or their aviation authorities after a period of operation. Routes were specified.

Many agreements of the Bermuda type were subsequently signed by each of the original partners with other States, and by other pairs of States. The Bermuda Agreement thus became a model which predominated during the next four decades although a large number of agreements, while incorporating the Bermuda principles, also employed

predetermination of capacity. Bilateral agreements produced a relatively stable and balanced regulatory foundation on which the international air transport system has sustained steady growth.

In the 1970s and 1980s various States adopted more liberal policies for the regulation of international air transport. As a consequence, some new liberal bilateral agreements were concluded, generally characterized by a removal of capacity restraints, greatly reduced government involvement in tariff matters, increased market access and the ability of each party to name more than a single airline to use that access.

The 1990s witnessed rapid changes in both the regulatory and the operating environments of international air transport, as well as structural changes to the airline industry. Liberalization became widespread. To adapt to the changes, many States made regulatory adjustments and adopted more liberal policies, typically by relaxing regulation to varying degrees. Some States concluded new liberal bilateral agreements which essentially remove all restrictions on market access, capacity and pricing (so-called "open-skies" agreements). There was also growing regionalism in international air transport regulation, converting some bilateral regulations to regional or subregional multilateral regulations.

In the decade which began in the year 2000, liberalization is expected to continue and grow, both under new or revised bilateral agreements and under other new arrangements, including collective regulation by groups of States, for example, on a regional or subregional multilateral basis. It could also include the use of new types of agreements such as a plurilateral agreement among like-minded States (see Chapter 2.4).

Chapter 2.1

PROCESS OF BILATERAL REGULATION

The process involved in bilateral regulation is very different from that of national or multilateral regulation. It typically begins when one State (or organization of States) proposes a joint quest for an air services agreement or understanding with another State (or organization of States) and the involved parties undertake their preparations. It continues through the actual meetings and negotiations between their representatives. The process does not end with the formal signing of a binding document; the formal conclusion marks the first step in managing the implementation of what was agreed. In that activity, States often return to the cycle of preparation, talks and outcomes to interpret, amend or expand their understandings, or at times to terminate them.

Thus the basic *process of bilateral regulation* is that of *consultation*, the communication and interaction between two parties, typically but not always two States, carried out over a period of time to question or inform, to establish or change a relationship or to resolve a dispute between them. The term consultation (or consultations) is applied to a broad range of such bilateral communications and interactions.

Formal consultation typically involves meetings of multi-person delegations led by designated chairpersons, each having appropriate delegated powers.

Informal consultation, on the other hand, may involve solely written, solely oral, or a combination of written and oral communication. It can take place in meetings between only two or a few persons (for example, an embassy civil aviation attaché of one State and a civil aviation official of the host State) at which a paper or papers may be provided or exchanged. Alternatively, it may occur by telephone, by electronic transmission of a message or, more traditionally, by the sending and receiving of an official document, usually through diplomatic channels.

A *negotiation* is a consultation, usually a formal one, which has become (or which, from the beginning, was intended to be) a process of bargaining between the parties. Thus, although all negotiations are also consultations, not all consultations are negotiations.

The next three sections of this chapter discuss the initiation of and preparation for a formal bilateral consultation, the types of meetings and documents employed in consultations and negotiations, and the strategic and tactical considerations involved in consultations and negotiations. It should be noted that the information provided in these three sections represents the optimum in States' practices; the process may well be less sophisticated in many bilateral consultations/negotiations. The final section describes the formal conclusion of an agreement and the processes involved in the implementation, management, dispute resolution and amendment or termination of an agreement.

INITIATION OF AND PREPARATION FOR A FORMAL BILATERAL CONSULTATION

A formal bilateral consultation usually begins with a request by one governmental party to another governmental party to hold talks. In the vast majority of cases, each party will be a national government; however, one or both could be an organization of States which has requisite authority from its members to hold the consultation. An informal consultation is then likely to take place about the venue and dates of the initial meeting, or possibly to determine whether a consensus exists about the desirability of holding a formal consultation.

Prior to requesting a formal consultation, the potential initiator has numerous determinations to make internally.

The most fundamental determination is that of the character or kind or basic type of consultation (and potential negotiation) that could occur. In the field of inter-governmental international air transport relations five such types are distinguishable by their basic objective.

An **innovation consultation** is one by which the initiating party seeks to establish a relationship for the first time (such as that characterized by a first air transport agreement between the parties) or to very significantly alter that relationship (such as by entry into an entirely new agreement in place of an existing one).

A **modification consultation** is one by which the initiating party seeks some mutually beneficial alteration in an established relationship (such as a mutual expansion in access, a mutual change in agreed capacity, or the addition of an aviation security article).

A **redistribution consultation** is one by which the initiating party seeks to obtain some net increase in opportunities or benefits for itself under an established relationship (such as new market access, carrier revenues or other gains measurably greater than its possible new concessions) so as to correct a perceived imbalance.

A **dispute resolution consultation** is one by which the initiating party seeks normalization, i.e. conformity of a situation to what that party perceives as appropriate under their agreement (for example, a situation such as that of a capacity increase by a carrier or carriers of the other party which the first party deems objectionable).

An **extension consultation** is one by which the initiating party seeks continuation of an agreed arrangement beyond a previously agreed date (such as the termination date of an agreement or some side understanding, for example one which established a temporary capacity regime).

Some consultations may possess the attributes of more than one type; however, certain attributes are likely to predominate. Knowing the character of a potential formal consultation is likely to be useful at all stages of the process.

Timing is another important preliminary consideration, not so much as regards detailed administrative arrangements and the availability of personnel, but as regards the broader setting or context:

- Are the parties involved in some major dispute in another (non-aviation) area?

- Is either party in a period of possible or actual change in government during which its internal policies and/or decision-making capabilities are in temporary flux?
- Would a time-related linkage of air transport consultations to some major future event (for example, visit by a head of State or head of government) have probable adverse or favourable effects on the outcome?
- Are the parties allied in some cooperative and important diplomatic effort during which one or both feels compelled to avoid any confrontation about an air transport dispute?

These considerations are likely to be undertaken by the diplomatic/foreign office component of a State's air transport authorities. While unlikely to be determinative of timing in most cases, they can be significant in some cases.

Other preliminary (although not necessarily determinative) considerations include:

- the degree of internal consensus (both within the requesting government and with and among its national air carriers and other interested parties);
- an assessment of the negotiating leverage available;
- some idea of what would constitute a successful consultation; and
- the probability of success.

Upon receipt of a request for formal consultation (or even in advance of a possible request) the other party has much the same determinations to make, but in many cases clearly from very different perspectives. For example, the receiving party in a dispute resolution consultation may well perceive its conduct to be fully in accord with the agreement. It may wish to avoid or defer consultation within the constraints of the dispute resolution procedures in the case of an existing agreement. In another example, the receiving party in a redistribution consultation may wish to avoid entirely, or at least to defer for the longest time possible, the outcome sought by the requesting party. However, most bilateral agreements contain a provision to reply to a request for consultation within a specified period of time (e.g. within 30 or 60 days).

If both parties agree to initiate a formal consultation, they are likely to consult informally on relevant adminis-

trative arrangements such as the date of initiation of the talks, the likely maximum period of availability of the respective delegations at the talks (or at the opening round) and the *negotiating venue*, a site in the territory of one of the two parties, typically a seat of government, or some other mutually agreed location. Some States follow a custom whereby the delegation of the requesting party travels to the territory of the bilateral partner for the first round, with subsequent rounds alternating between the two territories. In addition, the rank of an intended delegation chief can be a matter of concern to the other party, particularly if it is perceived to be too low or too high for the intended consultation.

Also as part of pre-consultation contacts, one or both parties may provide the other with proposed concepts or even proposed texts for consideration. This provision could include, when no agreement is already in place, a party's *model bilateral air transport agreement*, a standard format document which contains the regulatory arrangements the providing party typically seeks to include in such agreements, and the wording formulations it prefers.

During the pre-consultation contacts, the parties are also likely to indicate to each other the topics they wish to have considered and even a preferred order of consideration. Disagreements about the topics and their consideration may arise and persist or an informal or formal agenda may be agreed. Arrangements for interpretation may require agreement.

The amount and kinds of preparation undertaken by the parties during the pre-consultation period may differ widely. They will depend upon perceptions of the importance of the consultations, available personnel resources and the degree of time and effort the State is willing and able to apply to the task. Generally, each party gathers and analyses relevant quantitative and qualitative data.

The quantitative data gathered and analysed in preparation for a consultation are likely to include, *inter alia*:

- existing and projected air service and traffic volumes, market shares and relevant load factors (overall, in particular city-pair markets and on particular types of air services);
- historic or potential carrier revenues; and
- airports, tourism and trade data;

as related to known or anticipated issues.

The qualitative data gathered and analysed in preparation for a consultation are likely to include:

- facts about each party's relevant policies and overall air transport negotiating objectives;
- the known concerns of the air carriers of each party and of other interested entities;
- detailed information about matters in dispute or potentially at issue;
- information about positions taken or results achieved by the other party in similar circumstances;
- historical information on the bilateral air services relationship;
- information about members of the other delegation and how their particular interests might diverge from the general interests of that delegation; and
- information about bilateral air transport relationships of the other party with third parties (the *Digest of Bilateral Air Transport Agreements* (Doc 9511) contains summaries of the main provisions of all bilateral air transport agreements filed by Contracting States and a computer database maintained by ICAO keeps the information updated).

To prepare for the talks, each party is also likely to hold internal consultations (or further internal consultations) among the concerned governmental entities (typically those responsible for civil aviation and for foreign affairs, and sometimes others), as well as with the national airline(s) and interested non-governmental parties. Based on such consultations, and the prepared data, each party develops its confidential negotiating position. A *negotiating position* or *position paper* is an expression of international negotiating objectives and priorities which reflects the party's air transport policies, as well as possible negotiating fall-backs or alternative objectives, if any. It may also set out the major issues, scenarios for their outcome, strategies to be followed, data and analyses, the relevant views of interested parties, as well as comments on the anticipated positions of the other party. It usually requires the approval of higher authorities. When approved, it constitutes the instructions of the delegation.

The *delegation* or *negotiating team* is typically composed of civil aviation and diplomatic officials, representatives of the national airline(s) and in some cases other

interested parties (e.g. airport, city, labour, tourism), and is usually chaired by a designated civil aviation or foreign affairs official. When the consultation takes place outside the home territory, an embassy official is likely to be on the team. In some States, officials of relevant organizations will represent groups such as airlines, airports, cities and labour.

Decisions made when putting together the negotiating team can have important consequences both during the consultation and for its outcome:

- Should the head of delegation be the highest ranking official or should that person be an official from the customary lead ministry or department, even if of a lower rank? Alternatively, should diplomatic and negotiating knowledge, experience and skills be determinative of the selection?
- Should individual team members be chosen or assigned based solely upon required knowledge, experience and skills (such as in route analysis or tariff evaluation) or should the selection criteria include and give weight to the adequate representation of interested departments, bureaux, or interest groups?
- Should the number of individuals on the team be maximized within available resources so as to ensure a variety of potential contributions to the team effort or should it be minimized for greater efficiency in internal team decision making during the consultation or negotiation?
- When consultation with a second party tends to occur with some frequency, if not regularity, is it more important to maintain continuity of experience with the issues involved with that second party by assigning the same people, or more important to assign people on some other basis?

In practice, a scarcity of available personnel resources may dictate the team composition for all or many consultations. Alternatively, the decisions taken on team composition may reflect adherence to established practices and/or practical compromises.

The names and positions of the delegation or negotiating team are usually provided in advance to the other party, both as a matter of courtesy and for practical administrative considerations, such as for entry into secured premises, seating at the meeting table and representational social events.

CONSULTATIONS AND NEGOTIATIONS: TYPES OF MEETINGS AND DOCUMENTS

A formal bilateral consultation or negotiation usually begins with welcoming remarks by the chairperson of the host delegation and the chairperson of the visiting delegation, which are likely to include or be followed by introductions of the members of each delegation.

Administrative arrangements, such as agreed working hours and the availability of rooms where delegations may caucus privately, are indicated and possibly discussed. Agreement may be sought on what confidentiality the talks should have, in particular on whether there should be independent or joint statements to the communications media. The order in which topics are to be considered, which may or may not constitute a formal agenda, is likely to be mutually determined (if not done in advance). Social arrangements are announced.

Substantive oral communication between the delegations can take place in various fora, the most common being the *plenary*, any formal meeting between the two delegations. This contrasts with a *principals' meeting*, which is one limited to the chairpersons and most senior members of the delegations, or a *chairpersons' meeting*, a private meeting of the heads of delegations. The chairpersons may also appoint as appropriate, a *working group*, or *expert group* consisting of one or a few expert members from each delegation who are given the task of working out matters of detail or technical issues. When agreement on major issues is imminent or is reached in the plenary, the chairpersons may appoint a *drafting group*, which is composed of one or a few experts from each side who prepare the relevant texts covering the matters being agreed.

The terms *round*, *round of consultations*, *round of negotiations*, *consultation round* and *negotiating round* are imprecise ones variously used to denote either a period of time, usually one of days or weeks, during which the consulting or negotiating teams are together at the same venue or (alternatively) a series of such gatherings spaced over a longer period and held for a single purpose such as the conclusion of a new air services agreement.

Documents examined during a consultation or negotiation (after having been previously transmitted) or otherwise employed during or at the conclusion of a round of talks, are likely to have names used in diplomatic practice

which may be unfamiliar to air transport regulators, airline officials and other non-diplomats on or in communication with the negotiating team.

The **diplomatic note**, or simply **note**, is the most widely used form of written communication between an Ambassador or Embassy of one State and the host State's foreign minister (secretary) or ministry (department). The diplomatic note takes various forms. A **formal note** or **first person note** is a diplomatic note from the signer or initialling person which is likely to begin "Excellency (Sir), I have the honour to ... etc." as distinct from a **third person note**, which is a signed or initialled communication not written in the first person, a form which is most often reserved in modern practice for routine messages. It typically begins "The Embassy of ... presents its compliments to the Ministry of Foreign Affairs and ... etc." or "The Ministry of ... etc.". A **note verbale** is a note in the third person which, as a rule, is neither addressed nor signed. Some States consider a third person note to also be a note verbale, i.e. that there are only two types of notes, formal notes and notes verbales.

During a consultation or negotiation, one party to the discussion may present to the other an **aide-mémoire**, a paper which serves as a memorandum or written reference regarding the topic(s) of discussion. Alternatively, a **non-paper**, a rarely used document type which serves the same purpose but has no identified source, title, or attribution and no standing in the relationship involved, may be presented.

In the course of a formal consultation or negotiation, either delegation or both may employ some form of **consultation (negotiation) working paper**, however titled, a paper which provides information, sets forth a proposal, suggests draft language or serves some other temporary purpose confined to the talks themselves. In modern practice, in the course of a consultation or negotiation, whether formal or informal, either party's representatives may simply address the other party's representatives by letter, delivered by hand or electronically.

An **agreed minute** is an official record, agreed by both parties (typically State delegations to a consultation or negotiation) of what was said or done at a meeting. A **memorandum of consultation** is a less formal record of the outcome of a meeting which typically, but not invariably, does not constitute in itself an agreement or an understanding. An **agreed press release** or an **agreed joint press release** is sometimes issued to inform the public about progress in a consultation or negotiation.

When a consultation or negotiation results in an agreement on substance and text, the chairperson of each delegation will initial each page and each correction of the prepared text. This exercise of initialling their agreement serves as a guarantee of the text's authenticity prior to its reproduction in a form suitable for formal signature. An **ad referendum agreement** or **agreement ad referendum** is one which has been initialled and is being examined and reviewed by the competent authorities of each party (either because the negotiators do not have the power to commit their governments to the agreement or wish to have it reviewed by their governments, a process during which modifications of an editorial/technical nature, and sometimes agreed substantive changes, may be made) before it takes effect.

**CONSULTATIONS AND
NEGOTIATIONS: STRATEGIC
AND TACTICAL CONSIDERATIONS**

There are numerous strategic considerations and decisions which a head of delegation is likely to have to resolve, ones which may well have lasting impacts upon the entire round of meetings.

All negotiations and some consultations concern issues of actual or potential conflict between the parties and all deal with common interests. The common interests may be identical (for example, in the provision of needed air services by a carrier of one party to an airport in the territory of the other party), or complementary (for example, the opening of one new route by a carrier of one party and another new route by a carrier of the other party).

Each head of delegation has a basic choice between attempting to focus discussion on the issues in conflict, setting out the position of that delegation and perhaps the distinctions between it and that of the other party or, on the other hand, identifying and focusing on aspects of common interest which could form bases for agreement while de-emphasizing or remaining silent on the areas of conflict. The former approach may be seen as evidence of a firm resolve not to back down or compromise. The latter approach can produce a less confrontational and more positive climate. Its use, however, requires care to avoid conveying unintentionally an erroneous impression, either one of lack of resolve and determination to achieve objectives, or one of unimportance of the issues involved.

Some heads of delegation prefer to have statements of position or objectives on every issue “on the table” early in the round. Others prefer to remain silent or vague on their preferred or possible positions on various issues until they can assess the results achieved on other issues.

In a complex negotiation either or both negotiators may take the position that all issues must be resolved before any are agreed. This has the advantage of assuring interested parties that certain individual interests will not be forsaken in order to achieve agreement on other matters which might be deemed of greater importance. The principal disadvantage of this approach is that it stretches out the overall negotiating period and in so doing increases the risk that unforeseen outside factors may intervene to unravel the individual understandings reached but not definitively agreed pending an overall understanding on all issues.

Also, in a complex or otherwise difficult negotiation in which an impasse has been reached, either negotiator may suggest an exchange of papers presenting new ideas on how to overcome the impasse and proceed with the negotiation. Fresh ideas can have a positive aspect. The danger is that a comprehensive paper may be prepared by each side which is likely to focus on and exacerbate issues of conflict while locking in (assuming the position was achieved by an internal consensus) the party to a particular position from which compromise may not be possible. An even more risky result could come about should one party agree to negotiate on the basis of the other’s idea (position) paper.

A negotiator’s own role perception is also quite important. One view is that the principal role should be one of defender and advocate of the position of the negotiator’s government. An alternative view holds that the principal role of a negotiator is one of solving the other negotiator’s problems (in ways which, of course, resolve the problems and meet the objectives of the first negotiator).

Some negotiators may focus on reaching agreement to employ a particular regulatory arrangement or regulatory device (for example, a specific capacity formula). Others may focus on the broader objectives behind the use of a regulatory arrangement or device, thus increasing the probability of finding common grounds for agreement through some alternative arrangement or device.

Where negotiations are deadlocked after several rounds, some States have found it helpful to each assign, as negotiators/team leaders, higher level officials or appropriately experienced professionals not previously involved. Fresh, and without memories of failed bargaining efforts, yet with

the same or greater negotiating authority, they could employ new skills, strategies, tactics, etc. to break the impasse.

Alternatively, or additionally, negotiators could make greater or exclusive use of delegation chairpersons’ meetings, principals’ meetings, working groups or expert groups (all previously defined). Using yet another approach, each State could assign a prominent and experienced person not involved in the negotiations who would communicate privately with each other, attempting to devise a **framework agreement**, *in this situation a document containing the broad outlines of a package of mutually acceptable solutions, with the details left to be inserted later, possibly by a drafting group (with the risk, however, of a future deadlock over some details)*. Such an agreement could, in theory, also be reached using any of the above types of sub-delegation meetings, but in practice, a successful outcome by that route is less likely.

Another strategic consideration is whether or not to use any confidential side understanding(s). Such use denies transparency to the agreement and either means that a confidential understanding would lose its confidentiality when it became available to the public upon filing with ICAO (as required by Article 83 of the Chicago Convention) or that it would not be filed with ICAO and consequently each State’s obligation to file would not be fulfilled.

On the tactical side, a negotiator is likely to consider it objectionable for the other side to introduce a new issue of conflict or to make a new demand without adequate warning or an opportunity for that negotiator’s team to fully consider the matter. One approach which ameliorates this effect is to present the issue or demand as one which could be examined in a future round.

A negotiator may choose to employ warnings, threats, bluff or commitments. A warning is an effort to make the other negotiator or negotiating team aware of the consequences that are likely to follow from a failure on the other’s part to act in a certain way. A threat, on the other hand, is an assertion that the negotiator or the government the negotiator represents will act explicitly in some way to bring about some loss to the government represented by the other negotiator. A bluff is a threat which the threatener is not determined to carry out. A commitment, in this context, is some action taken or to be taken by a negotiator, or the government of that negotiator, to lock either one into a difficult-to-change position (for example, one created by new legislation which is difficult to amend or repeal). When presented as a warning or a threat before any action is taken, a commitment may provide negotiating leverage.

The use of specificity and ambiguity have both tactical and strategic considerations. Each has different purposes.

Specificity can lock in one party's interpretation of a particular arrangement and make the arrangement clear to all. The danger is that as specificity increases, the usefulness of the text can be reduced when circumstances change over time.

Ambiguity, in which each party may be tacitly left free to provide its own interpretation, is an often useful tactical device to get around some issue which cannot be resolved. To the extent a text is purposely ambiguous, it might be termed equivocal. Strategically, like a partial agreement it intentionally leaves some issue for possible future conflict and possible future resolution. (Note that equivocation in expressing a negotiating position is quite a different matter and adds to the user's flexibility while increasing the difficulties of the other negotiator.)

**CONCLUSION, IMPLEMENTATION,
MANAGEMENT, DISPUTE RESOLUTION,
AMENDMENT AND (EXCEPTIONALLY)
TERMINATION OF AN AGREEMENT**

The text(s) of a formal agreement, as prepared during the *ad referendum* process, will normally be identical for each party in all respects except one. That is, each State is entitled to **precedence**, *i.e. placement of the name of one State in the title, opening, and signature block, before that of the other State in the basic agreement document retained by the first State.*

The formal signing of an agreement sometimes takes place at a ceremony at which designated officials of the governments party to the agreement sign the agreement. Before a formal signing, the designated officials of each party may make available to the other their **Full Powers**, *i.e. a document emanating from the competent authority of a State designating a person or persons to represent that State for negotiating and concluding a treaty/agreement with another State.* Agreements can also be formally concluded by an exchange of diplomatic notes. Some States have a national requirement that bilateral agreements be subject to **ratification**, *a process of examination and approval by the appropriate governmental elements or legislature which must be concluded before the agreement can take effect definitively.*

States may decide, for practical reasons, to have the agreement enter into force on a provisional basis immediately after the signature, followed by a final entry into force after each party has notified the other that it has performed the acts necessary for ratification.

A State may also assume the rights and obligations of an agreement between two other States by **succession to a bilateral agreement**, *a formal statement by a State formerly under the jurisdiction of a party to a bilateral agreement that it will assume the rights and obligations that pertain to it under that agreement.* This arrangement is often temporary, for example, until a State newly independent of the jurisdiction of one of the parties can negotiate its own agreements, but in some cases the arrangement may continue indefinitely. Succession to air transport agreements has been accomplished by unilateral declaration to that effect made to the Secretary General of the United Nations or by entry into a memorandum of understanding or exchange of notes with the former sovereign party or the other party to the relevant agreement.

Typically the first action taken by a State to implement a bilateral air transport agreement is the designation or formal naming of its air carrier(s) to perform services under the agreement. It is normally done by diplomatic note. The carrier(s) may then apply to the second State for appropriate operating authority.

States use consultation on a continuing basis to manage the relationships established by their bilateral air transport agreements. Technical problems in bilateral air services relationships are typically handled by routine consultation between the air transport authorities of the two States.

Consultation is virtually the only means of dispute resolution used between parties to bilateral air transport agreements. The principal advantage of consultation for dispute resolution is the use of a familiar method, usually by people who understand the issues. The principal disadvantage is that the only parties involved are those who are likely to have well-established views on the issues and are thus less likely to be sufficiently objective and flexible to resolve the dispute.

Bilateral agreements may also provide for **arbitration**, *a means of dispute settlement where the issues are referred to an arbitral tribunal for resolution. An arbitral tribunal is usually made up of three arbitrators, one nominated by each party and the third (usually a national of a third State) nominated by the first two, the third person acting as its*

President, who decide specific, mutually agreed question(s) concerning actions in dispute under the bilateral air transport agreement.

Some agreements provide that if the parties or their nominees fail to name their arbitrators within the specified time a prominent person such as the President of the Council of ICAO or the President of the International Court of Justice be requested to do so. The tribunal usually decides on its own procedures. The two States may, however, negotiate the questions to be decided, what documents will be presented and the order in which each State will present its witness(es) and written and oral arguments. A decision of an arbitral tribunal is binding on both parties. Arbitration is rarely used because it is a costly and time-consuming process.

The use of **good offices**, *i.e. impartial assistance by a third State, an international organization, or prominent individual to persuade the two parties to negotiate their differences* is rare in air transport dispute resolution. Similarly exceptional is the use of **mediation**, *i.e. conciliatory efforts by a third State, an international organization, or a prominent individual which not only bring about negotiation between the parties but do so on the basis of proposals made by the mediator.*

Some States consider that an adverse unilateral action in a bilateral dispute (for example, suspending a foreign airline's authorization) is not permissible until the dispute resolution procedures of the agreement (including arbitration if agreed) have been exhausted. Other States maintain that a **proportionate action**, *i.e. one taken by a party which preserves or restores but does not enhance that*

party's position, may be taken before or during consultation or arbitration, or failing the implementation of an arbitral decision.

Amendments or modifications to the bilateral agreements are agreed upon through consultation between the parties. They may be embodied in a memorandum of understanding, agreed minute, exchange of letters, or protocol, but are usually effected by an exchange of diplomatic notes.

Most bilateral air transport agreements do not have an expiry date, but almost all have a termination article or denunciation article. (Certain parts of a bilateral agreement, for example possible temporary understandings on capacity, may expire on their own terms after a specified period of time or some agreed occurrence.) **Denunciation** of an agreement is the formal notice given by one party to the other party to the agreement of the first party's intent to cease being bound by the agreement, usually as of the end of a period specified in the agreement. (In a rare case, it may be possible to denounce an agreement only in part.)

Denunciation is uncommon, but may follow a failure of dispute resolution procedures. The normal expectation is that during the period between denunciation of an agreement and its consequent expiry, the parties will be able to negotiate a new agreement. Should renegotiation fail, in the absence of a new agreement States are likely either to make ad hoc arrangements to enable air services to continue between the two countries or choose to end air services between their territories by the respective air carriers and rely upon the air carriers of third countries to provide services.

Chapter 2.2

STRUCTURE OF BILATERAL REGULATION

The *structure of bilateral regulation* of international air transport is that of a large and growing body of documents, each of which constitutes an agreement, understanding or arrangement between two States, and thus a part of international law. In contrast to both national and multilateral regulation, bilateral regulation involves no permanent institutions or organizations.

To explain the structure of bilateral regulation, the first section of this chapter identifies the basic document types used in the bilateral regulation of international air transport. The second section defines or describes the typical provisions of bilateral air transport (services) agreements. The final section identifies several types of bilateral agreements on subjects closely related to air transport.

BASIC DOCUMENT TYPES

A bilateral *Air Transport Agreement* or *Air Services Agreement*, the basic document most often used by States to jointly regulate their international air services relationships, is likely to consist of a textual body (preamble, articles, signatures), an annex or annexes, possible attachments and any agreed amendments. Such an agreement is often referred to by those who work regularly in the regulation of international air transport simply as a “*bilateral*”.

Most bilateral air transport agreements cover only scheduled international air services, but a few also regulate non-scheduled international air services. A *Non-scheduled Air Services Agreement* or a *Charter Agreement* regulates non-scheduled or charter air services separately from scheduled international air services. A *Memorandum of Understanding (MOU)* is a less formal type of agreement which, notwithstanding the lesser formality, may be as

binding as a formal agreement and may cover either or both types of international air services.

A *Chicago Agreement* or *Chicago-type Agreement* is one patterned on a standard form bilateral international air transport agreement drafted at the 1944 Chicago Conference for use as an interim measure to exchange routes and traffic rights pending the conclusion of a multilateral air transport regulatory regime, an objective which was not reached. (The text may be found in Recommendation VIII of the Final Act of the Chicago Conference, 7 December 1944.) Capacity and tariffs were not to be regulated under such a regime, therefore a Chicago Agreement typically does not have capacity and tariff provisions, with an assumption that their exclusion implies non-regulation of these matters by either party. Relatively few Chicago-type agreements remain in effect.

The *Bermuda Agreement* between the United Kingdom and the United States, signed at Bermuda on 11 February 1946, effected a compromise between advocates of detailed regulation and those of non-regulation of basic matters such as capacity and tariffs and in effect, established the *Bermuda-type Agreement* as a model for many other bilateral air transport agreements worldwide. However, a large number of agreements subsequently concluded between States (over half of the bilateral agreements registered with ICAO), while incorporating the Bermuda principles and terminology (see Chapter 2.0), also employ a predetermined approach to capacity regulation. On 23 July 1977 the original Bermuda Agreement was replaced by a more complex and detailed *Bermuda II Agreement*, thus the original agreement and agreements patterned after it have come to be known as the *Bermuda I Agreement* and the *Bermuda I type Agreement* respectively.

Soon after conclusion of the Bermuda II Agreement, and following the start of deregulation in the United States in 1978, a number of States entered into agreements

generally known as **liberalized air agreements** which are characterized by greater market access, minimal (if any) capacity regulation and significantly reduced governmental controls on air carrier pricing. Some include other liberalizing provisions as well, on matters such as charter flights, all-cargo services, and computer reservation systems.

With the spread of liberalization in the 1990s and in a return to an idea first espoused in 1942, and subsequently during and immediately after the Chicago Conference, some partner States have concluded a so-called **Open Skies Agreement**, a type of agreement which, while not uniformly defined by its various advocates, would create a regulatory regime that relies chiefly on sustained market competition for the achievement of its air services goals and is largely or entirely devoid of a priori governmental management of access rights, capacity and pricing, while having safeguards appropriate to maintaining the minimum regulation necessary to achieve the goals of the agreement.

To facilitate and assist States in their regulatory reform and adjustment, ICAO has developed, for optional use by States, two **template air services agreements (TASAs)**, one for the bilateral context and the other for regional or plurilateral situations; each includes provisions on traditional, transitional and most liberal approaches, including optional wording, to the various elements in an air services agreement of its type. Explanatory notes are also provided for the use of the corresponding options or alternative approaches. The TASAs can be found in Doc 9587 — *Policy and Guidance Material on the Economic Regulation of International Air Transport*.

**TYPICAL PROVISIONS OF
BILATERAL AIR TRANSPORT
(SERVICES) AGREEMENTS**

Although bilateral air transport agreements and air services agreements, which number in the thousands, generally tend to have the characteristics of a particular type of agreement, each one is unique. Nevertheless, these agreements typically have in common numerous types of essential provisions most of which, while not identical, have a similar thrust. Such commonly found provisions are identified in the following paragraphs.

The **Preamble**, which is the initial part of the agreement, identifies the **contracting parties** or simply **parties** (the two involved governments), presents their reasons for

entering into the agreement, and declares that they have agreed to what will follow in subsequent parts of the agreement.

An **article** is the primary sub-part of the agreement, is typically numbered sequentially, and may or may not be titled; may in some cases identify several such sub-parts taken collectively when they deal with aspects of the same subject (such as capacity or tariffs); and, in the latter sense, is identical in meaning to **bilateral clause** (although **clause** also identifies a subsection of an article).

A **definitions article**, often the first article of the agreement, assigns meanings for the purposes of that agreement to terms used in the text, typically those used more than once.

A **grant of rights article** expresses the main purpose of the agreement, that of the grant by each contracting party to the other contracting party of rights specified in that article or elsewhere, such as in the route schedule(s), to operate the agreed air services.

A **fair and equal opportunity article** (or some variant thereof such as “fair and equitable” or “fair”) sets forth a general principle which each party to an agreement may rely upon to ensure against discrimination or unfair competitive practices affecting its designated carrier(s). Alternatively, the principle may be stated in a clause in the capacity article or elsewhere in the agreement. The article is sometimes expanded to specifically require consideration of the interests of the other party and its air carrier(s). The opportunity provided is for the designated carrier(s) of each party and may be stated as “to compete” or “to operate”.

A **designation and authorization article** grants the right to name an air carrier, or more than one air carrier, to operate the agreed services and establishes the limited conditions under which the other party may deny an operating authorization to such carrier(s). The conditions for denying (including withholding) of an operating authorization are typically those of substantial ownership and effective control not being vested in the designating party or in its nationals, and/or an insufficient disposition to conform to the laws and regulations of the receiving party and/or an inability to meet airworthiness standards. More recently, some agreements have used an alternative to the typical ownership and control requirement by allowing the acceptance of a designated airline which is incorporated and has its principal place of business in the territory of the designating State.

A **revocation or suspension of operating authorization article** grants each party a right to revoke or suspend the operating authorization already granted to an air carrier of the other party if the carrier no longer meets a specified condition, usually one of the same conditions established for the grant of such authorization.

A **capacity article** lays down the agreed principles or method for regulation of the amount(s) of services offered or to be offered under the agreement. Detailed models of a pre-determination type capacity article, a Bermuda I type capacity article, and a free-determination type article were developed by ICAO to provide guidance on three alternative regulatory approaches to capacity clauses and may be found in Doc 9587.

A **tariff article** establishes procedures for the establishment and regulation of prices on the agreed air services. Detailed models of a double approval clause, a country of origin clause and a dual disapproval clause were developed by ICAO to provide guidance on three alternative regulatory approaches to tariff clauses or articles and may be found in Doc 9587, along with discussion of further alternative approaches to tariff regulation, such as “tariff zone” and “country of designation”.

A **statistics article** typically provides for exchange of airline traffic data related to the agreed services, either periodically or as needed for the regulation of capacity, for route evaluations, or for other purposes.

A **commercial operations article** or **commercial opportunities article** (or articles) specifies the rights granted to each party’s designated air carrier(s) to carry out commercial activities in the territory of the other party. These rights are sometimes referred to as “**doing business rights**” or “**soft rights**” and are likely to include the establishment and extent of foreign staffing of airline offices, sales in local or convertible currency, ground handling options, currency conversion and remittance of funds by airlines, and in some cases, airline cooperative arrangements such as codesharing and/or leasing arrangements. It may also cover access to landing and take-off slots at airports and/or use of computer reservation systems (CRS). An **airport slots article** and/or a **computer reservation systems article** are sometimes used to cover these two “soft rights” separately.

“**Hard rights**” has come into some use as a collective term of contrast to include route, traffic, operational and capacity rights which are considered more valuable and enduring, hence “hard”. Pricing rights are sometimes

placed in one category and sometimes in the other. In some agreements, one or more of the “doing business rights” listed above are given their own distinct articles.

A **fair competition article**, a relatively new inclusion in some recent bilateral agreements, especially liberal ones, lays down agreed general principles and/or specific provisions governing competition in the provision of air services by the parties’ designated airlines.

An **airworthiness article** typically provides for the mutual recognition by the parties of each other’s certificates of airworthiness, certificates of competency and licences. This provision is sometimes placed in a **safety article**, which also covers an agreed course of action for the parties to take concerning the maintenance of safety standards (such as consultation procedures and corrective action requirements).

An **aviation security article**, an addition in recent years to many bilateral air transport agreements, sets forth procedures for cooperation between the parties to avoid or deal with situations involving acts or threats of unlawful interference with the security of civil aviation. In 1986 the Council of ICAO adopted a model bilateral aviation security clause for the use of Contracting States (see Doc 9587).

A **customs duties and taxes article** requires each party to exempt from duties, taxes and charges, the aircraft fuel, spare parts and supplies used by the other party’s air carrier(s) (see also ICAO’s Policies on Taxation in the Field of International Air Transport (Doc 8632)).

A **taxation article** (in the absence of a separate tax agreement) exempts from taxation the corporate earnings of the air carrier(s) of the other party and may, in some cases, extend to cover the earned incomes of air carrier employees (see also Doc 8632).

A **user charges article** sets forth agreed principles regarding charges for the use of airports and route air navigation facilities by the designated air carrier(s) of the other party (see also ICAO’s Policies on Charges for Airports and Air Navigation Services (Doc 9082)).

An **application of laws article** establishes that the national laws of one party related to the operation, navigation, and admission and departure of aircraft apply to the air carrier(s) of the other party.

A **consultation article** sets forth the agreed procedures for consultation between the parties or their aeronautical

authorities (often with a time requirement for the consultation to take place) and may include an **amendment clause** (sometimes a separate **amendment article**) which establishes procedures for amending or modifying the agreement.

A **settlement of disputes article** sets forth agreed measures for resolving disputes between the parties. Such measures routinely include consultation and sometimes arbitration.

A **termination article** or **denunciation article** specifies how a party may end its commitments under the agreement, typically one year after receipt by the other party of a formal notice to that effect. Some agreements provide for a shorter notice period, such as six months, or in exceptional cases, allow for denunciation or termination of only parts of the agreement.

A **multilateral agreement article** provides that if a multilateral agreement accepted by both parties, concerning any matter covered by the agreement, enters into force, the agreement shall be amended so as to conform with the provisions of the multilateral agreement.

A **registration article** reiterates the obligation of the contracting parties (when both are Contracting States of ICAO) to register the agreement with ICAO, as required under Articles 81 and 83 of the Chicago Convention.

An **entry into force article** establishes how and when the agreement will take effect, typically upon the conclusion of an exchange of diplomatic notes. It may specify provisional effectiveness and may or may not anticipate a process of ratification by either or both parties.

The **signature provisions** at the end of the agreement indicate the date and place of signature and specify the language versions. Although most agreements having more than one language version provide that each version is equally authentic, agreements can provide that in the event of conflict between the language versions, the text of one specified language will prevail.

The agreement may have one or more than one **annex**, an attachment usually considered to be part of the agreement, which typically sets forth route, traffic and operational rights but may also or separately cover other topics (e.g. capacity, charter flights). The subjects of an annex are usually ones which, in contrast to the articles in the main body of the agreement, are likely to be modified from time to time by the parties or their aeronautical authorities to

respond to changed circumstances. An annex can usually be amended more quickly than an article of an agreement, particularly if formal ratification of an amendment to an article is required under the laws of either party. The most common annex is the **route annex** which contains the **route schedule(s)** or descriptions of the routes over which the designated airline(s) of each party may operate the agreed services, and the conditions or restrictions applicable to certain or all routes.

To facilitate and assist States in their regulatory liberalization, ICAO has developed a comprehensive bilateral template air services agreement which has all the articles typically found in a bilateral air services agreement (*Policy and Guidance Material on the Economic Regulation of International Air Transport* (Doc 9587)).

A **protocol** is an attachment to an agreement which clarifies, adds to, or in some cases, amends it. An **exchange of letters**, or more than one such exchange, supplements an agreement or understanding, typically by setting forth in the initiating letter one party's statement on a particular action, interpretation, policy, supplemental understanding, etc., and in the letter of response, the other party's acceptance or acknowledgement.

**TYPES OF BILATERAL AGREEMENTS
ON SUBJECTS CLOSELY RELATED
TO AIR TRANSPORT**

In addition to bilateral air transport agreements, States have concluded certain other types of bilateral agreement on subjects closely related to air transport.

An **agreement on the avoidance of double taxation relating to air transport services** is an agreement not to tax the corporate earnings of airlines of the other party, and in some cases, the incomes of the airline employees of the other party. Alternatively, two States may have a more general agreement on taxation which obviates the need for one limited to air services tax matters.

A **preclearance agreement** is an agreement which permits some or all of each party's or only one party's entry formalities (e.g. customs, immigration, agriculture, public health) to be carried out in the territory of the other State.

An **agreement on airline crew visas** is one which facilitates the entry of airline crew members of one party into the territory of the other party, often by waiving the visa

requirement or by granting multiple entries. Some States may extend such treatment to resident airline staff of the other State.

Agreements on certificates of airworthiness, agreements on communications, agreements on duties on fuel (now rare, this topic typically being included in air transport agreements), *agreements on meteorology* and *agreements*

on search and rescue cover the topics indicated by their titles and may also be concluded by those who negotiate air services agreements.

An *aviation security agreement* serves the same function as an aviation security article in the absence of a comprehensive air transport agreement or air services agreement.

Chapter 2.3

KEY ISSUES OF BILATERAL REGULATORY PROCESS AND STRUCTURE

This chapter discusses five key issues of the bilateral regulatory process and structure:

- 1) balancing benefits in a liberalizing environment;
- 2) the shortcomings of bilateral regulatory structure, such as lack of transparency and inadequacy of dispute resolution mechanisms;
- 3) bilateral relations involving groups of States;
- 4) application of competition law to air transport; and
- 5) effects of State aids/subsidies.

The practice of using bilateral agreements and arrangements to regulate international commercial air services is content-neutral, that is, the regulatory regime may range from one of detailed governmental regulation of tariffs, capacity and routes, to one where the bilateral partners allow their airlines wide latitude to serve the market as they wish. Thus, the question is not whether bilateral agreements are, by their nature, restrictive or liberal, but whether or not States wish to continue to use such agreements (and if so, how) to meet their need to participate in a more competitive international air transport system marked by new commercial and marketing initiatives of air carriers.

**BALANCING BENEFITS IN A
LIBERALIZING ENVIRONMENT**

States have consistently used the bilateral regulatory process to create bilateral regulatory structures to achieve the

numerous benefits they seek. The negotiating process thus necessarily seeks such benefits, and the resulting structures (i.e. air transport agreements) thus necessarily are devised to provide such benefits. When concluding the negotiating process, each Party independently satisfies itself that a balance of benefits (or an imbalance favourable to it) has been achieved.

While “fair and equal opportunity” has been accepted by many States as a general principle in the bilateral exchange of rights, traditional bilateral air service agreements are often based in practice on the concept of a balance of measurable benefits (traffic carried or revenues earned or projected to be carried/earned) by the respective air carriers of each State. Market access is thus granted (or restricted) in an effort to achieve an approximate equality of results for those air carriers in the carriage of traffic between the two States (the “penetration” approach). However, many other bilateral air service agreements are based on a balance of opportunities or equal access to the markets in each State, without an expectation that the air carriers of the respective States should or would achieve a quantitative balance in results (the “access” approach).

Bilateral regulation of international air transport has the flexibility to accommodate the policies of a wide range of States of different sizes and at different stages of economic development, with air carriers of varying strengths and capabilities. States often rely on bilateral air service agreements to promote and/or protect the international air service of their national air carrier(s). Consequently, a State’s participation in the international air transport system is largely measured in terms of the commercial operations of its national carrier(s).

The tendency of international air carriers to seek to maximize their access to and penetration of global and

regional markets by using cooperative commercial arrangements (such as pooling and interlining) with other international air carriers has always been present but is now taking new forms (joint ventures, code sharing, alliances, mergers, franchising) with several implications for the process and structure of bilateral regulation.

The implications of these developments for the process of bilateral regulation include the following:

- Where the air carriers involved in cooperative arrangements such as code sharing have extensive market access in third States, they can substantially affect traffic flows to and from such States. This may require either or both bilateral partner States to consult or negotiate with a substantial number of third States to secure any necessary authorization for the aspect of the cooperative activity which occurs in their jurisdictions.
- Negotiating a bilateral balance of benefits becomes more difficult when a substantial portion of the benefits are derived in third States and when benefits must be apportioned between and among air carriers in, for example, a joint venture. In the future, negotiators may have difficulty in determining on behalf of which air carrier(s) they are negotiating, for example, where there is substantial investment by a foreign air carrier in a national air carrier.
- The value of the benefits themselves becomes more difficult to quantify when several international air carriers are involved in, for example, a joint marketing arrangement.

The implications of these developments for the structure of bilateral regulation include the following:

- Some cooperative arrangements, for example involving air cargo, can be seen as efforts to avoid restrictions in bilateral air services agreements and thereby, in effect, to operate outside the bilateral framework.
- Other cooperative activities, such as code sharing, could be prevented on some routes and permitted on others because of the inconsistent treatment or definition of traffic rights among the bilateral agreements with involved third countries.

- Extensive investment by foreign air carriers in national ones could undermine the concept of a bilateral balance of benefits based on nationally owned and controlled airlines.

The growth in the number of bilateral air services agreements itself has tended to undermine the traditional concept of a balance of benefits between air carriers of the two States. As bilateral air services agreements proliferate, there are more and more potential opportunities for air carriers of third States to serve bilateral city pairs indirectly, via their homeland. This increase in opportunities for so-called “sixth freedom” services may be heightened by air carriers resorting to “hubbing” operations within their States. As more and more traffic between city-pairs of bilateral State partners moves indirectly via third countries, it becomes more difficult to measure the bilateral traffic flow which has its true origin/destination in the two bilateral partner States.

Adapting bilateral air services agreements to new cooperative activities of international air carriers may require the use of new criteria to determine a bilateral balance of benefits. These might include, for example, measuring the balance in terms of international air services per se (regardless of which air carrier provides them) or in terms of according the same market access in both countries for all designated air carriers (without the need, for example, to balance the opportunities in terms of an equal number of traffic points for the designated air carriers of the respective States). At present, in some instances, States consider the benefits of increased tourism and/or exports by air to be sufficiently important, in effect, to justify exceptions to the principle of a bilateral balance of benefits measured in terms of the results for the respective designated air carriers.

Use of the foregoing criteria may overcome or ameliorate the balance of benefits issue. It would not, however, eliminate a need in some circumstances to deal with a substantial number of third States which are affected by cooperative arrangements authorized bilaterally. This could perhaps be lessened somewhat if States could agree on standard definitions of terms which reflect the rights air carriers seek via cooperative arrangements. For example, if a substantial number of States were to agree that the term “traffic rights” included the right to code share or use a blocked space arrangement to serve a market, there would be less need to deal bilaterally with all the States affected by a cooperative air carrier activity.

SHORTCOMINGS OF BILATERAL REGULATORY STRUCTURE

One shortcoming of the bilateral regulatory structure is a lack of transparency, i.e. openness of agreements and understandings reached and accessibility by non-party States and individuals with an interest in their contents. Although States are required by Articles 81 and 83 of the Chicago Convention to file all aeronautical agreements with ICAO where they are open to inspection, some agreements, especially side agreements such as memoranda of understanding, are kept confidential and not filed with ICAO, other agreements are filed only after delays of many years and some agreements are not filed by either party.

Full compliance with the requirement of the Chicago Convention to file all agreements with ICAO could significantly increase badly needed transparency. One possible way to improve this situation, as recommended by ICAO, is to include a provision in their bilateral agreement which clearly designates a party (for example, the party of the place of signature of the agreement) to be responsible for the registration of their agreement upon its signature or entry into force (which can be found in Doc 9587).

A second and perhaps more serious shortcoming is the inadequacy of the dispute resolution mechanisms contained in bilateral air transport agreements. These agreements generally provide a consultation mechanism, arbitration procedures and a termination clause. When a dispute arises between the parties that is resolved in a fairly short time by informal or formal consultation procedures, no shortcoming exists. If, however, the parties remain deadlocked in the consultation process, their only options are:

- to consult again, with the probability that positions would not have changed and the additional consultation would fail; and/or
- to invoke arbitration, a process so costly and time-consuming that its use in air transport regulation has been extremely rare; and/or
- to take unilateral action which the other party is most likely to regard as a violation of the agreement and a basis for similar action on its part; and/or
- to give notice of termination of the agreement (typically one year's notice is required) and, following termination, to attempt to resolve the problem on the basis of comity and reciprocity.

This shortcoming could possibly be overcome by the use of impartial experts (acting as individuals or in panels), preferably independently selected, under rules and procedures designed for very rapid dispute resolution at minimal cost. Based on this concept, ICAO has developed a mediation mechanism, in the form of a model clause, for optional use by States additional to and in between the traditional consultation and arbitration processes (which can be found in Doc 9587).

A third and significant shortcoming stems from its ad hoc character. Although the use of bilateral air services agreements allows States to take into account each other's differing circumstances and situations, it also produces a wide variation in how certain key issues, such as traffic rights, capacity and tariffs, are treated. Thus, each bilateral air transport agreement tends to be somewhat unique in nature and can only be reliably implemented with an understanding of its particular circumstances rather than by reference to standard terminology. For example, an agreement may:

- adhere to the standard format of preamble, articles and one or more annexes, yet have its own particular order of articles, subject titles, placement of agreed elements, annex structure, etc.; and/or
- mix standard texts for capacity and price regulation but have deviations or inconsistencies (such as incorporating so-called "Bermuda principles" of capacity regulation yet intending or allowing for the predetermination of capacity); and/or
- have been intended to be a State's standard form or model text, yet contain many deviations sought by the partner State that reflect compromises reached.

A fourth shortcoming that can create significant problems for multi-country operations is the difficulty in obtaining and maintaining the essential consistency in route descriptions in each of the agreements involved. For example, an air carrier would generally find it helpful and perhaps necessary, when operating a long linear route which requires stops in several countries, to have the ability to take on and discharge passengers and cargo at each stop. This would require the State designating the air carrier to secure the appropriate rights from each State where a stop is made which may take an inordinate amount of time or which may not be possible. However, with the trend of liberalization, this situation may be improved when States concerned conclude liberal (e.g. open skies) agreements providing for more open market access and route rights.

A fifth shortcoming is the lack of standard definitions of terms, i.e. the terminology employed in various bilateral agreements may be defined differently, even in conflicting ways, by different States (for example, fifth and “sixth” freedoms).

One way to ameliorate or overcome these shortcomings would be to continue to expand the practice of using “model clauses” (such as various ones developed by ICAO) in addition to certain standard terminology taken from the Chicago Convention. A second way might be to create a multilateral framework agreement composed of standardized articles or clauses on relatively non-controversial subjects to serve as an “umbrella” for bilateral agreements which would contain provisions for sensitive topics such as agreed market access and capacity and pricing regulation. A third way would be to create a well drafted plurilateral or multilateral agreement text; however, its design would have to ensure adequate recognition of the differences between particular bilateral relationships that are now reflected by the ad hoc character of bilateral agreements. In this regard, the template air services agreements recently developed by ICAO (Doc 9587) could be a useful tool that will assist in the standardization process.

BILATERAL RELATIONS INVOLVING GROUPS OF STATES

With the growth of regionalism, at times accompanied by some unification in the economies, as well as the inter-governmental relations of the States involved, issues arise over whether, and if so how, other member States of a group (such as an economic union) or the regional body itself should become involved in the extraregional bilateral air transport relations of individual member States. Each ascending level of such involvement presents separate issues.

The first level of involvement by a non-party (to a bilateral relationship between a member State of a regional group and an extraregional State) could occur when such a member State consults and/or coordinates with another or other member State(s). Such consultation and/or coordination could:

- help standardize the extraregional bilateral agreements of member States;
- mitigate possible concerns of other member States that the results of the consultation or negotiation could prejudice their interests;

- lengthen and/or complicate the consultation or negotiation; and
- increase the difficulties of reaching agreement because non-party interests are involved.

A second level of involvement could be the physical presence at the bilateral consultation or negotiation of a representative or representatives of other member States of the group or of a group representative, as observer(s). Considerations for both parties to the bilateral meeting include:

- what would be the benefits or disadvantages;
- whether the non-member party would accept the presence of any such observer(s);
- how would the role of non-party observer be delineated; and
- which non-party States would be represented, with the assumption that the interests of those not represented would either be adequately represented or not be affected by the negotiation.

Note that the above considerations would not exist in joint bilateral negotiations where one member of a regional group has been duly authorized to negotiate on behalf of all members of the group.

A third level of involvement could be the actual conduct of the bilateral consultation or negotiation by a representative of the regional group on behalf of a member party. Such involvement could raise questions of:

- acceptability to the extraregional party of dealing with a non-party negotiator;
- potential uneasiness on the part of the member State party about being represented by a non-national negotiator; and
- possible doubts on the part of the extraregional party about the ability and willingness of the member State party to fully carry out the terms of any agreement reached.

Note that the above questions need not arise in a joint bilateral negotiation with member State parties on one side and an extraregional party on the other.

A fourth level of involvement could be the conduct of the bilateral consultation or negotiation by a representative

of the regional group where the two signatory parties are or would be the extraregional State and the regional group as a single entity. Such a potential consultation or negotiation:

- may have, as a *raison d'être* of the regional group, the perception of greater negotiating leverage than possessed by member States acting individually;
- may well be perceived by outside States, in particular developing countries, as threatening;
- can only be undertaken by a supra-State that has powers over member States sufficient to ensure that what it has agreed will be carried out; and
- may produce an agreement which could be perceived by the group members as benefiting one of the member States more than (or to the detriment of) another.

Note that a regional body that lacks the legal and institutional structure of a supra-State and thus could not be an obligated signatory party could nevertheless conduct joint bilateral negotiations, i.e. at the third level of involvement.

A final consideration is that while consultations or negotiations at the above levels are or could be considered as being multinational, they are all bilateral or joint bilateral, not multilateral, in character. The distinctions are that:

- multilateral consultations/negotiations/agreements deal with binding relationships of each party to each other party or to all other parties as a collective, whereas at each of the above levels the regional group member State parties maintain separately governed relationships with each other; and
- the relationships at each of the above levels are with only one outside party; therefore, withdrawal by that party from the agreement would terminate it (as in the case of any other bilateral agreement and in contrast to a multilateral agreement which would normally continue after denunciation by a single party).

**APPLICATION OF
COMPETITION LAWS TO
AIR TRANSPORT**

International air transport is a commercial activity where strongly differing views exist among States as to desirable

levels of protection, competition and industry cooperation. Prior to the 1990s, States, individually or collectively, generally either did not apply national competition laws to international air transport, or exempted it from the scope of such laws, sometimes with certain conditions designed to mitigate perceived anti-competitive effects. Consequently, bilateral air transport agreements contained no clauses which dealt specifically with the application of competition laws, although some agreements did contain certain competition principles and commitments to avoid unfair or predatory practices.

Since then, with increasing globalization and widespread adoption of the market economy, there has been a marked rise in the adoption of competition laws by States, spreading gradually from developed economies to other parts of the world. By 2003, some 90 countries had competition laws of some sort. As liberalization progresses and takes hold in more States, the traditional concepts to ensure fair competition tend to gradually give way to the application of competition laws, particularly in cases where States have agreed to an open competition system.

In recent years, the use of such laws to deal with air transport has occurred not only with more frequency but also has encompassed an increasing number of issues, ranging from antitrust immunity, mergers and alliances, abuse of dominant position, capacity dumping and predatory pricing, sales and marketing, to airport charges and fees, State aid and loan guarantees.

A major challenge facing air transport regulators is how to define or distinguish between normal and anti-competitive practices. While efforts have continued at national and international levels to devise competition guidelines, reliance has increasingly been placed on analyses and development of standards through a case-by-case approach. To address this issue, ICAO has developed, as part of a safeguard mechanism in the form of a model clause, an indicative list of possible anti-competitive practices which States may use in identifying unacceptable behaviour in the marketplace and in considering appropriate regulatory action (which can be found in Doc 9587).

One of the potential problems associated with the application of national competition laws is the differing, sometimes even conflicting, regimes employed by States (for example, regulations dealing with mergers or alliances, denied boarding). This could cause particular difficulties for airlines operating international air services when they have to cope with different rules in different countries. While repeated efforts have been made at the international

level with a view to harmonizing competition regimes, global consensus has proven to be difficult to obtain, due to the different legal systems involved and the disparity in their scope and content. It is therefore important that States, when dealing with competition issues involving foreign air carriers, give due consideration to the concerns of other States involved and avoid taking unilateral action.

The extra-territorial application of national competition laws could also undermine certain airline cooperative arrangements (for example, interlining, tariff coordination) which are regarded by many as essential for the efficiency, regularity and viability of international air transport. Where antitrust or competition laws apply to such arrangements, States often grant immunity or exemptions, sometimes with certain conditions, to permit inter-carrier cooperation where they benefit users and air carriers.

With respect to disputes that may arise from applying national competition laws or the various safeguard measures, States usually rely on the consultation process available under relevant air services agreements. In this regard, ICAO has also developed a number of specific guidelines for States and a model clause for air transport agreements on the avoidance or resolution of conflicts between States over the application of national competition laws (which can be found in Doc 9587).

While national and regional approaches to competition laws continued to differ, a number of bilateral antitrust enforcement cooperation agreements have been entered into by States, particularly between developed countries. These agreements have proven useful for dealing with matters such as cartels and mergers/alliances. At the same time, there has been recognition that enforcement cooperation alone would not resolve some significant areas of procedural and substantive differences among antitrust regimes, and that these differences would need to be addressed.

**EFFECTS OF
STATE AIDS AND SUBSIDIES**

Unlike other commercial sectors, participation is an expectation in international civil aviation. This could be traced to Article 44 of the Chicago Convention which mandates ICAO, as an objective of the Organization, to “Insure that the rights of contracting States are fully respected and that every contracting State has a fair opportunity to operate international airlines.”

The ability of an airline to sustain its operations and continue participating in international air transport is not only dependent upon its relative input cost base and productive efficiency, realized under different market circumstances, but also is often supported by various direct, indirect or implicit State assistance.

State aids/subsidies to air carriers by governments have existed since the beginning of commercial air transport. They have been provided at all stages of national or aviation development and have taken a wide variety of forms.

At the bilateral level, State assistance has also in effect been common because the bilateral air transport framework itself has conventionally provided a non-monetary form of implicit assistance to national air carriers in their own markets by limiting the scope of competition. Liberal air services agreements concluded in recent years have substantially reduced or eliminated such implicit assistance by a State in some markets.

The objectives of State assistance are varied, but as regards the international arena, have often been aimed at maintaining the participation of national air carriers in the air transport markets concerned and at ensuring continuity of air services to/from their territories. Developing countries, in particular, are concerned about overdependence on foreign carriers to provide international air services, especially in bad times when the services may be adversely affected. Some States also regard the survival of their own air carriers as a definite means of providing an effective assurance of services.

However, State aids/subsidies which confer financial benefits on national air carriers that are not available to competitors in the same international markets could distort trade in international air services and can constitute or support unfair competitive practices.

For example, a national air carrier which receives a fuel subsidy for all international flights would potentially enjoy an unfair competitive advantage in all international markets in which it competes directly or on an interline basis. If the national air carrier uses its fuel subsidy to consistently charge less on routes on which it is a significant competitor, there would be an adverse impact on competing air carriers.

There are a number of different State aids/subsidies that may distort competition. In the form of financial aids to national air carriers, they include but are not limited to:

- the provision of State funds for the purposes of covering operating losses, avoiding insolvency, financing of restructuring or expansion;

- partial or full cancellation of air carrier debt to the government;
- the guarantee of loans;
- the giving of “soft” loans (i.e. at below-market rates of interest or with insufficient collateral); and
- the assumption of air carrier debt owed to other parties.

Other State aids/subsidies may take a less direct form, yet still provide the air carrier with a financial benefit. These include such items as:

- preferential tax treatment;
- funding of unemployment benefits to national air carrier workers whose services are declared redundant;
- measures in bankruptcy laws which, after a declaration of insolvency, grant legal relief from certain financial obligations for extended periods in order to permit the air carrier to continue operations while attempting to reorganize; and
- cross-subsidization measures, for example, charging higher airport fees for international than domestic flights, thereby benefiting national air carriers which operate both types of flights.

All the foregoing State aids/subsidies have the potential to enable the air carrier receiving them to engage in anti-competitive actions, such as excessive capacity, and predatory pricing.

There are also State aids/subsidies which can adversely and unfairly affect competing non-national air carriers. These include, for example, State aids/subsidies of a direct nature, such as payment of security costs for national air carriers (but not those of foreign air carriers).

Other types of State aids/subsidies may distort competition and adversely impact competing international air carriers by reserving certain segments of the market to national air carriers. Examples include the requirement that originating international mail be shipped only or predominantly on national air carrier(s) and so-called “buy national” policies, which require that all or most governmentally paid air transport be on a national air carrier.

In an increasingly competitive environment, an increasing number of air carriers, particularly privatized ones, are concerned about competitors that continue to receive State aids/subsidies. To minimize the potential adverse effects on competition in the marketplace, particularly in the case of direct financial aids/subsidies, several States (and groups of States) have developed rules on State aids/subsidies, which provide criteria to meet very specific objectives only where better alternatives are unavailable.

The major practical complication is the difficulty in quantifying the full scale of State assistance owing to the existence of various indirect or implicit assistance measures. Only direct aids/subsidies in monetary form can be quantified to some extent, although different accounting methods and reporting practices make it difficult to produce a comparative assessment of them. Furthermore, actions by States over perceived levels of assistance that may be considered to distort competition have the potential to lead to retaliatory actions by other States in view of differing attitudes towards such assistance.

The legitimacy of a State aid or subsidy depends upon its capacity to cause an adverse or distortive effect on competition. It can do so, for example, by enabling the benefited carrier to offer a below-cost tariff. Yet objectively the correct cost data to back up a claim of distortive effect is problematic. The allocation of costs to particular city-pairs involves an arbitrary decision. There may be a plethora of discount fares and conditions. Modern yield management techniques and marginal pricing allow some seats on a flight to be sold below fully allocated cost while still covering the marginal cost of filling an otherwise empty seat.

It is also very difficult to determine the impact of a one-time State aid granted to certain carriers in order to compensate them for losses incurred in situations such as government-imposed closure of airspace or an airport. The situation becomes worse in cases where such financial aid is considered by competing foreign carriers as beneficial to the recipient carriers to the extent that it represents a figure that is more than the actual loss incurred by the compensated carriers. An anti-competitive effect may also come from a State’s (typically a developed State) provision of unlimited war risk insurance coverage to its airlines. Similarly, State aid in the form of an unfair allocation of scarce airport landing and take-off slots can be considered distortive of competition. Again, a variety of assumptions and arbitrary conclusions could be involved in any assessment.

In a situation of transition to liberalization or in an already-liberalized market, there may be exceptional

circumstances where State assistance can produce economic and/or social benefits even though such assistance may affect market competition. So far as the ad hoc aids/subsidies are concerned, financial restructuring may serve to facilitate the transforming process of less efficient airlines as was the experience in the European Union.

The government decisions on airline restructuring finances are usually made against a background of social and political pressures to save national airlines and to ensure that the transition to more efficient operations is achieved at the lowest cost to those most affected, in particular to labour and creditors. However, without well-defined conditions (including goals, adequate time frame and long-term plans) and stringent regulatory mechanisms for enforcement, information disclosure and monitoring, restructuring finances could have the effect of simply protecting less productive airlines without fostering internal efficiency. Restructuring finance of airlines, therefore, needs to be accompanied by clear criteria and methodology if it is to achieve its intended purpose.

Some forms of subsidies in support of minimum levels of air services to remote areas may also be justified from the social interest perspective, provided that they are allocated transparently and effectively. In such circumstances, they can ensure the provision of a service satisfying fixed standards of continuity, regularity, capacity and pricing, standards which the air carrier may not assume if it were solely considering its commercial interest.

A traditional method to meet such social needs has been to rely on implicit ways such as cross-subsidization across the network through the strict regulation of market entry and tariffs, but the regulatory cross-subsidization system is considered neither transparent nor likely to stimulate efficiency.

A more effective and transparent alternative may be to provide direct financial subsidies for non-remunerative local services with institutional arrangements such as competitive tendering/bidding systems that clearly define selection criteria applicable to the ways in which subsidies are awarded. Since the tendering/bidding systems grant subsidies and operating rights to the most efficient carriers,

they may serve to keep the costs of subsidies low, as demonstrated by the domestic experiences in several States. At issue is to what extent this mechanism used in domestic contexts could be applied to international services.

With respect to participation aspects of State assistance through air services agreements, some special supportive measures deviating from the traditional bilateral arrangements based strictly on reciprocity may be justified to help instil the required level of confidence among various States to pursue diligently the processes of liberalization.

For example, in the case of air services arrangements with a developing country, such assistance may take the form of *preferential measures*, i.e. *non-reciprocal regulatory arrangements which States in a regulatory relationship agree are needed by a developing country for its effective and sustained participation in international air transport*.

In other cases, States may consider *participation measures*, i.e. *regulatory arrangements which are available to all States and are designed to build confidence for States involved in progressively moving to a less restrictive regime and to ensure that the results of increasing competition, while not equal, do not become too unequal* (e.g. in respect of capacity, tariffs and market access).

In this regard, ICAO has developed a list of potential preferential measures and participation measures which can be found in Doc 9587. In addition, a model clause has also been included in the ICAO template air services agreements (also contained in Doc 9587) to address the participation issues as transitional measures. All these are designed to provide less competitive carriers with an unreciprocated right or preparation time to enable them to develop a service that cannot be contested fully by competitors in a certain period. In this way, States with less competitive carriers may be more likely to commit to stepping forward to progressive liberalization. For example, preferential measures can provide a “head start” for less-competitive airlines wishing to have greater opportunities (for example, by granting more traffic points), and allow a developing country to introduce liberalization progressively (for example, to open up its market at a later stage).

Chapter 2.4

TYPES OF INTERNATIONAL AIR SERVICES NEGOTIATIONS

The growth of regional economic communities or unions of States, and the public consideration being given in some such communities and by individual States to group negotiations involving an organization of States (and/or intra-group consultations regarding negotiations by a member State), has created a need for a typology of possible patterns. The initial diagrams in this chapter show a typical **bilateral negotiation** (Type 1), *i.e. a negotiation between two parties, most often between two sovereign States*, and a much less typical **joint bilateral negotiation** (Type 2), *i.e. a simultaneous negotiation between one State and two or more other States regarding separate bilateral agreements* (which are likely to occur when two or more States have the same airline). They then set forth various types which do or would involve an organization or organizations of States (Types 3 through 8). The diagrams identified as Types 9a, 9b and 9c show variants of ways to develop a new form of agreement, one which could arise through a process which overlaps the typical bilateral negotiation and the multilateral negotiation (Type 10).

The type of international air services negotiation that occurs most frequently is the typical bilateral negotiation between two sovereign States (see Type 1).

In some situations, joint bilateral talks may facilitate reaching separate but similar agreements, particularly when certain States have the same airline (for example, Denmark, Norway and Sweden) (see Type 2).

Bilateral agreements can sometimes be facilitated by working through an organization of States. This occurred, for example, in the negotiation of detailed annexes to the 1982–1991 Memorandum of Understanding between the United States and certain European Civil Aviation Conference (ECAC) States about North Atlantic pricing (see Type 3).

A State which is a member of an organization of States may consult with and receive input from partner States of a group as it carries on bilateral talks with a non-group member State (for example, negotiations between one European Union State and a non-EU State) (see Type 4).

A variant of this could be negotiation between two States, each being a member of a group of States and each consulting with and receiving input from partner States of their respective organizations (for example, talks between a State in the Caribbean Community (CARICOM) and a State in the European Union) (see Type 5).

Another type of bilateral negotiation could involve a State on the one hand and a group of States on the other (for example, the negotiation between the European Union and Switzerland concerning the integration of the latter into the European Economic Area (EEA)) (see Type 6).

Similarly, it could involve two States jointly negotiating separate agreements (with much in common) with a group of States, but wishing to exclude air services between their territories (for example, possible talks between two North American States and the European Union) (see Type 7).

Future bilateral negotiations could even occur between two groups of States (for example, between the Andean Pact and the European Union) (see Type 8).

Negotiations could also occur for a **plurilateral agreement**, *i.e. an agreement that could initially be bilateral but be capable of being expanded to involve additional parties* (the so-called “**expanding bilateral**”) (see Type 9a) or could, from the start, involve three or more parties, in both cases parties that share similar regulatory objectives which are not so widely held as to make feasible a typical multilateral negotiation (see Type 9b). It would likely be open to other States to join. This is exemplified in the “open skies”

agreement concluded by several members of the Asia-Pacific Economic Cooperation Forum (the “Kona Agreement”).

A variant of the plurilateral agreement could come about if certain parties wish to exclude the coverage of air services between their territories (see Type 9c).

In contrast to all of the above types, the typical multi-lateral negotiation involves many more parties within a global, regional or other multi-party grouping, which may or may not all share similar regulatory objectives but negotiate together to create an agreement, usually one open to other States to join (see Type 10).

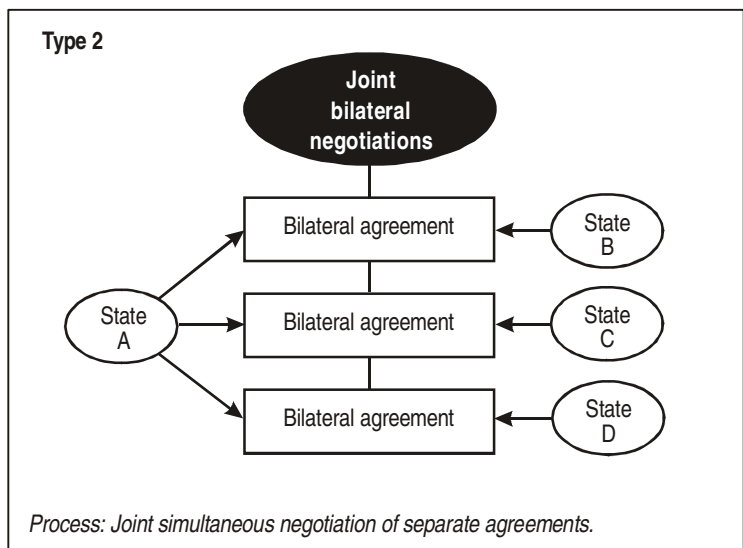
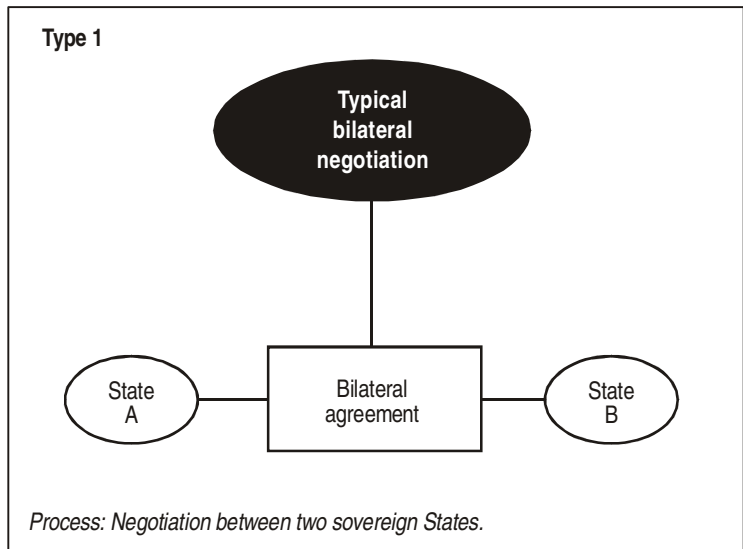

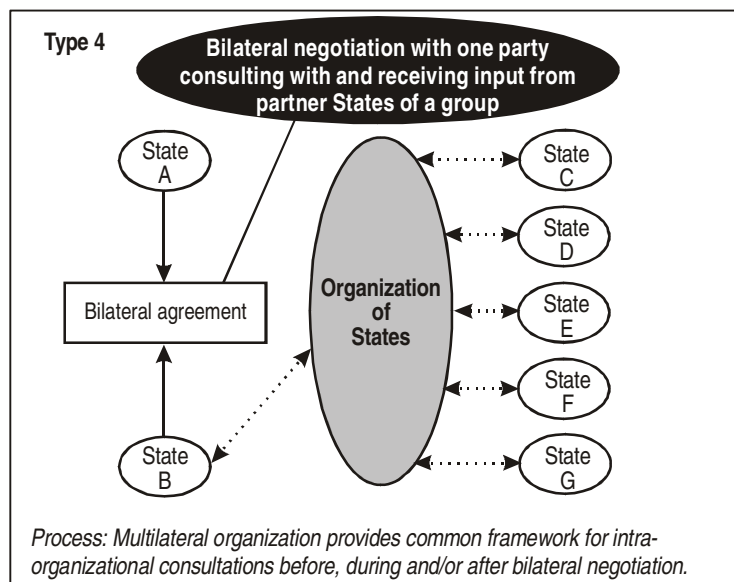
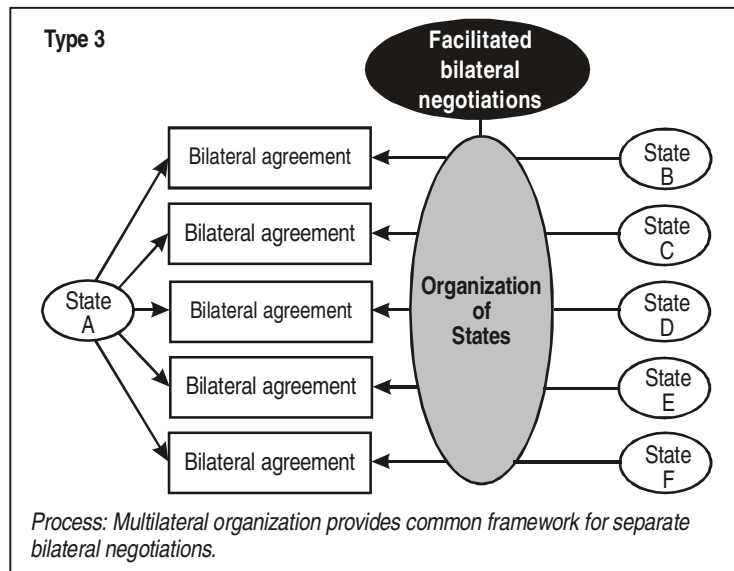

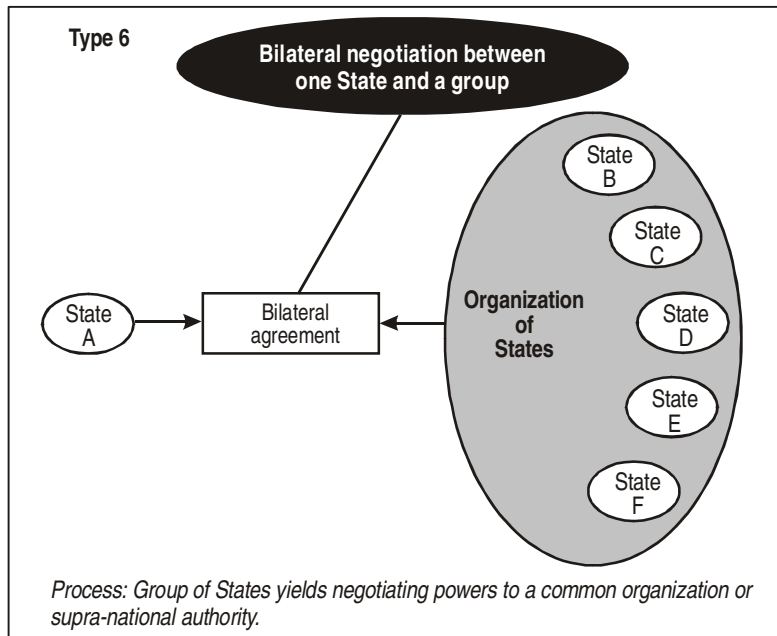
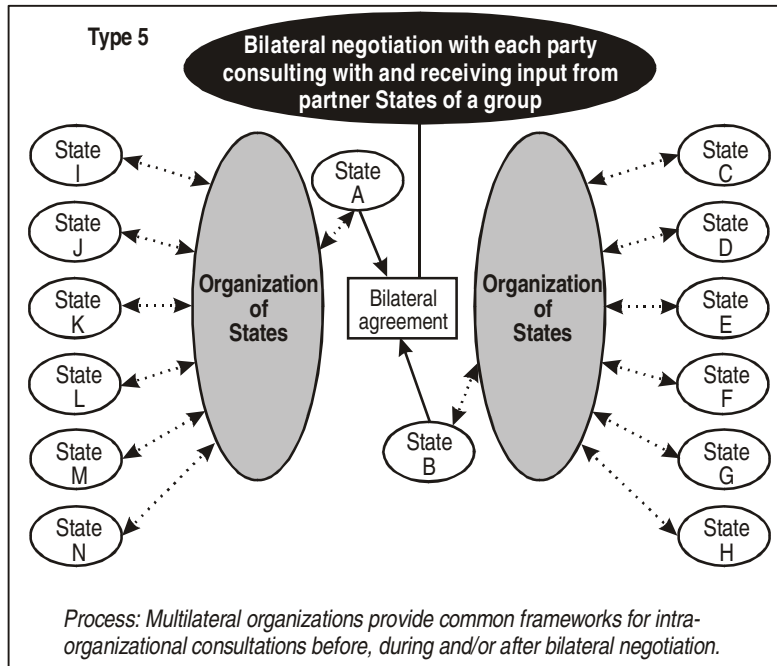

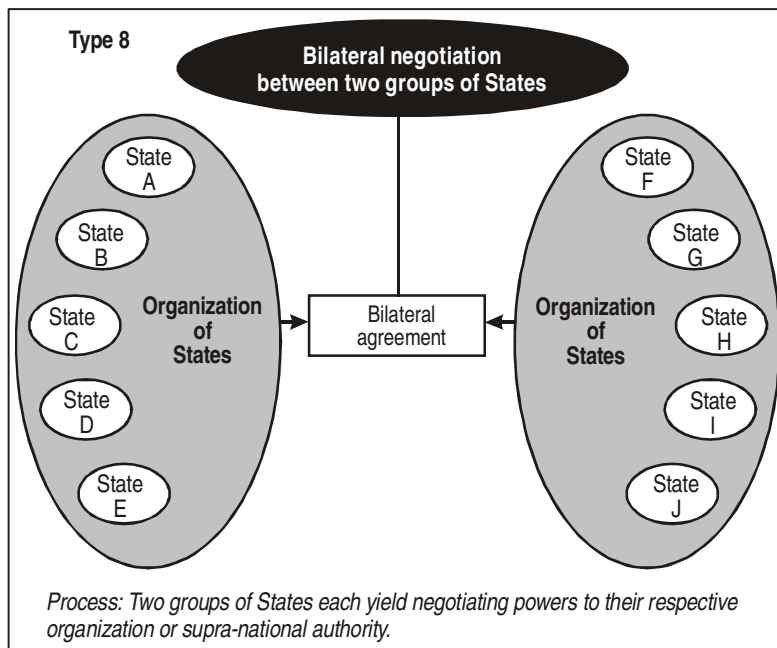
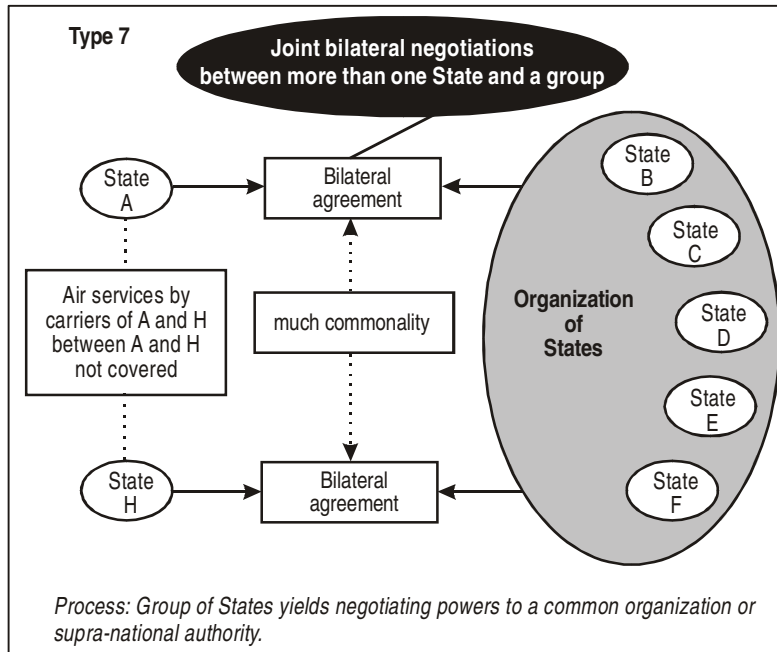

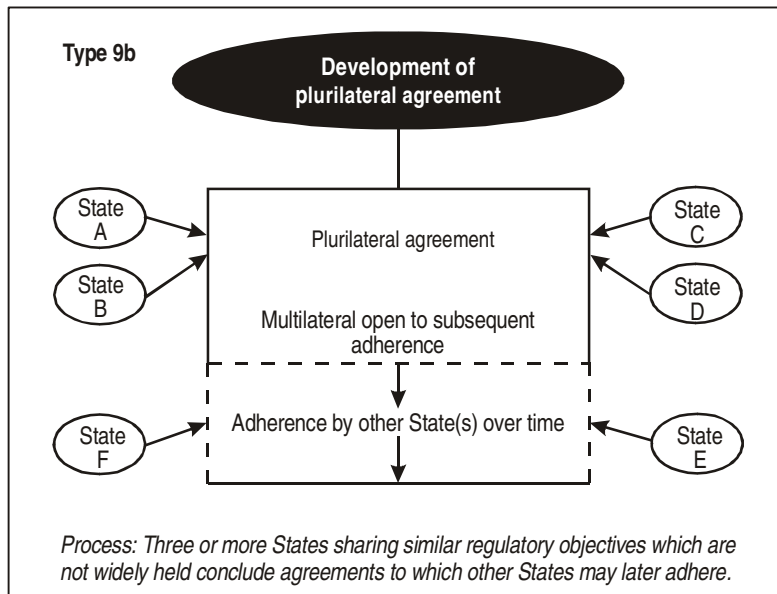
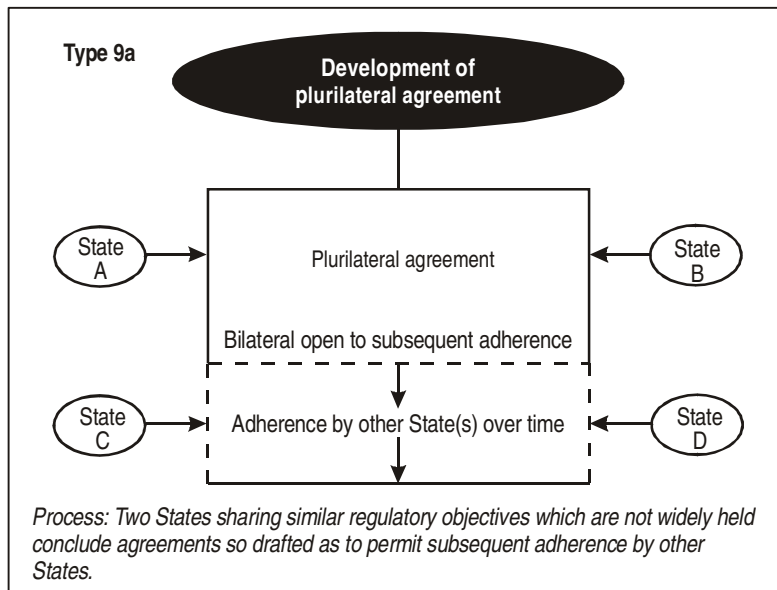

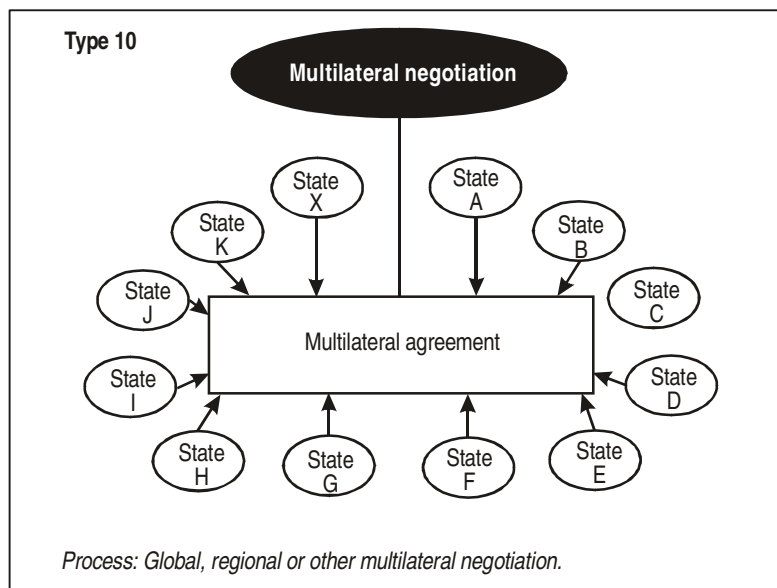
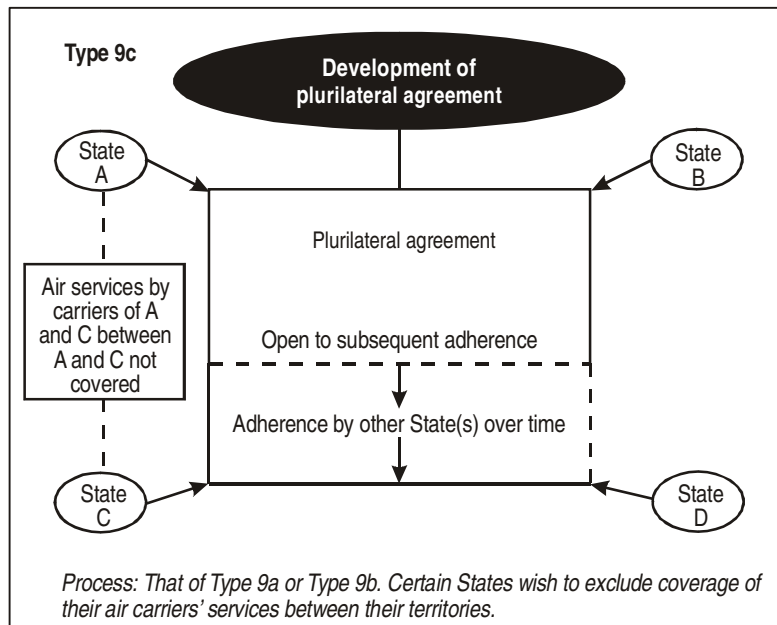

Part 3

MULTILATERAL REGULATION

Chapter 3.0

INTRODUCTION TO MULTILATERAL REGULATION

Multilateral regulation is regulation undertaken jointly by three or more States, within the framework of an international organization and/or a multilateral treaty or agreement, or as a separate specific activity, and may be broadly construed to include relevant regulatory processes and structures, outcomes or output written as treaties or other agreements, resolutions, decisions, directives, or regulations, as well as the observations, conclusions, guidance and discussions of multinational bodies, both intergovernmental and non-governmental.

The goal of multilateral regulation in the air transport field is, for the most part, the conclusion, implementation, or continuance of common arrangements, policies, agreements or regulations on matters of interest to the various parties. This chapter provides a brief history of the multilateral regulation of international air transport.

The most basic process of multilateral regulation is that of communication and interaction at multinational meetings undertaken to examine issues, adopt recommendations or resolutions, or conclude or amend intergovernmental or non-governmental agreements. Multilateral processes also include ad hoc and recurrent interactions between international organizations as well as activities particular to the operation of treaties. Chapter 3.1 explains process in the field of multilateral regulation.

The structure of multilateral regulation has an institutional component made up of many intergovernmental and non-governmental organizations. In addition, the structure of multilateral regulation has a legal component embodied in numerous multilateral treaties and similar instruments as

well as in binding and non-binding resolutions, recommendations and decisions of international organizations. Chapter 3.2 explains the first component by describing features such organizations have in common and the second by identifying certain generic terminology of the legal component as well as relevant worldwide and regional treaties and agreements.

Chapter 3.3 examines certain key issues of process and structure in the multilateral regulation of international air transport.

Chapter 3.4 is devoted exclusively to the International Civil Aviation Organization (ICAO).

Chapters 3.5 to 3.7 identify certain other intergovernmental organizations: Chapter 3.5, worldwide intergovernmental organizations other than ICAO; Chapter 3.6, regional intergovernmental civil aviation organizations; and Chapter 3.7, other regional and trans-regional intergovernmental organizations.

Chapter 3.8 is devoted solely to the International Air Transport Association (IATA).

Chapter 3.9 identifies other worldwide, regional and trans-regional non-governmental organizations which represent air carriers or other aviation interests or otherwise have air transport interests.

Part 4 of the manual presents the topics which make up the subject matter or content of regulation.

A BRIEF HISTORY OF THE MULTILATERAL REGULATION OF INTERNATIONAL AIR TRANSPORT

The history of multilateral regulation in the field of international air transport could be said to have begun in 1910 when the Government of France invited twenty-one European States to an *International Conference of Air Navigation* in Paris. This was the first multilateral diplomatic conference convened to consider international aspects of flight across State boundaries. No agreement was reached, but the notion arising from and debated at the meeting that States have and should exercise sovereignty over their airspace ultimately became the basis for air transport regulation.

The 1910 conference laid the groundwork for a 1919 diplomatic conference during which an *Aeronautical Commission of the Peace Conference* drafted the *Paris Convention for the Regulation of Aerial Navigation*, also known simply as the *Paris Convention*, an accord (adopted by the 1919 Paris Peace Conference) which, *inter alia*, confirmed the notion of States' sovereignty over their airspace. Ultimately, 38 States became parties to this accord. The *International Commission on Air Navigation (ICAN)*, a permanent Paris-based organization with a full-time Secretariat, was entrusted with the execution, administration and updating of the Paris Convention. Due to serious shortcomings of the Paris Convention, however, several major aviation States of that time chose not to ratify it and some States sought alternative accords.

In 1926, an abortive attempt was made at Madrid, Spain, to create an *Ibero-American Convention Relating to Air Navigation*, also known as the *Madrid Convention*, an accord virtually identical to the Paris Convention but with equality for States rather than weighted voting. It did not enter into force. A *Pan-American Convention on Commercial Aviation*, also known as the *Havana Convention*, similar to the Paris Convention in content but with no provisions for a governing body, was signed in 1928 and subsequently ratified by 16 States in the Americas. In the 1930s several other multilateral conventions to regulate international civil aviation were concluded for application mainly on a regional basis including, in Latin America, the *Buenos Aires Convention of 1935* and, in Europe, the *Bucharest Convention of 1936* and the *Zemun Agreement of 1937*.

The *Chicago Conference*, called by the United States at the time of World War II and opened at Chicago on 1 November 1944, had as its most important outcome the signing of the *Convention on International Civil Aviation* (the *Chicago Convention*) at the ending of the Conference on 7 December 1944. This Conference also produced the International Air Services Transit Agreement, the International Air Transport Agreement, drafts of 12 technical Annexes to the Chicago Convention and a Standard Form of Bilateral Agreement. The *Interim Agreement on International Civil Aviation*, also produced at the Chicago Conference, brought into being the *Provisional International Civil Aviation Organization (PICAO)*. PICAO as well as its permanent successor, the International Civil Aviation Organization (ICAO), sought, *inter alia*, to produce a more widely acceptable alternative to the International Air Transport Agreement, but without success.

The negotiation and conclusion of a relatively large body of worldwide air law conventions, chiefly involving liability and security, then became the focus of multilateral activity in this field. Also, the increasing regionalization of international economic activities came to be reflected in the development of air transport policies, regulations and even air transport agreements at a regional level. Increasing internationalization, globalization, liberalization and trans-nationalization, as well as the inclusion of some aspects of air transport under a General Agreement on Trade in Services (see Chapter 3.3), have created renewed interest in new multilateral arrangements for the regulation of international air transport.

Chapter 3.1

PROCESS OF MULTILATERAL REGULATION

The multilateral regulatory process is very different from that of national or bilateral regulation. The chief distinctions are that:

- more entities are involved (governments, international organizations, companies) and they are based in numerous States;
- the decisions taken and agreements reached have limited enforceability, if any, in most cases; and
- relatively little use is made of this process to exchange air transport market access rights or to regulate their use.

The basic *process of multilateral regulation* is that of communication and interaction:

- among parties from three or more States at formal or informal meetings (typically but not always conducted by or under the auspices of an inter-governmental organization or a non-governmental organization) undertaken to exchange information and views on matters of common regulatory concern and/or to develop and seek agreement on joint policies and/or practices regarding aspects of regulation;
- between an international organization and other entities (such as its members or other organizations) in other than a meeting context; and
- between entities involved in a multilateral treaty.

The multilateral meeting is the most fundamental element of the multilateral regulatory process. The first section of this chapter describes, in generic terms, the basic steps, procedures and documentation likely to occur at formal multilateral meetings. (Informal multilateral meetings are likely to have many of the same elements.)

The next section identifies, also in generic terms, the basic processes likely to be undertaken by an international organization having a formal structure and staff and involving itself in some way with multilateral regulation.

The final section discusses the multilateral treaty process.

FORMAL MULTILATERAL MEETINGS

A formal multilateral meeting called by and held under the auspices of an international organization (intergovernmental or non-governmental) is the most typical way taken to exchange information and views on matters of common regulatory concern to participating entities from various States and/or to develop and seek agreement among such parties on joint policies and/or practices regarding aspects of regulation. The meeting could be convened as well by a State or States, especially when no appropriate organization exists or when an objective of the meeting is to create such an organization.

Multilateral meetings are convened at regular, predetermined times or as needed for specific purposes. A multilateral agreement establishing an international organization usually specifies when regular meetings of the principal body or bodies will be held and the procedure to be followed in convening such meetings.

Any meeting among numerous parties having equal status requires a more formal process than that typically found in national or bilateral regulation (which requires some formality due to diplomatic protocol and agreed consultation procedures). The multilateral process typically involves a large number of parties having equal status (which are likely to have varying outlooks and objectives)

and thus requires a far more structured order if it is to succeed. Questions of what is to be discussed, in what order, with what documentation, in which languages and with what kind of record keeping can assume much greater significance in a multilateral context. An absence or failure of an agreed, orderly process can introduce confusion and an unproductive shift in discussion and debate from substantive topics to procedural questions.

Once a decision has been taken to convene a meeting, invitations are extended and invitees are informed about the purpose, dates, venue, provisional agenda and/or topics to be discussed, as well as administrative arrangements, and are requested to name those who will attend as representatives of the invited entity.

The formal multilateral meeting may use an accreditation process to ensure that participants do in fact represent the particular invited entities. *Accreditation is an official designation, made by the accrediting government, organization or other entity, of a person or persons to represent it at the meeting concerned.*

Delegations may be asked to submit their *credentials*, i.e. documents naming them and signed by or on behalf of the entity they represent which provide evidence of their accreditation. A very formal and large meeting may establish a credentials committee to ensure that only those authorized to do so participate in the meeting.

The accredited participants from a State or organization are referred to collectively as a delegation. A large formal multilateral meeting is likely to register participants and to classify them, e.g. as chief delegates, delegates, alternates, advisers or observers.

A formal multilateral meeting is likely to be conducted under some pre-established rules which may govern:

- what constitutes a *quorum*, i.e. the agreed minimum number of delegations required to be present at the meeting before it can validly conduct business;
 - discussion procedures;
 - voting procedures;
 - the use and establishment of subsidiary bodies of meetings, e.g. working groups or committees;
 - situations in which the meeting is open to the general public and/or the communications media; and
 - other possible activities or occurrences.
- The documentation of the meeting will be in one or more pre-agreed languages. Translation and/or simultaneous interpretation may also be provided.
- The documentation used at a formal multilateral meeting is likely to have been prepared by a secretariat, a delegation or delegations or, in some cases, by a *rapporteur*, a person appointed to prepare reports, studies, etc., for a meeting or conference. Each kind of documentation for a formal multilateral meeting is likely to have a particular type name customarily assigned to it; however, certain document type names have acquired widespread international usage. They include:
- *agenda*, a list of topics to be discussed/decided at the meeting, including a possible *provisional agenda* which, after review and acceptance by the meeting, becomes an *adopted agenda*;
 - *order of business*, or *provisional order of business*, a paper which indicates the order or tentative order in which agenda items and various papers relevant to them are to be discussed;
 - *working paper*, a paper which provides information, sets forth a proposal, suggests draft language or serves a similar purpose and invites action by the meeting;
 - *information paper*, a paper intended solely to provide information, not to be acted upon, but to be noted;
 - *flimsy*, a brief paper having no formal status typically used to provide a written formulation of a proposal or statement made during the discussion;
 - reference or background material;
 - delegation list;
 - administrative announcement;
 - *addendum*, an addition to any paper;
 - *corrigendum*, a correction to any paper; and
 - other documentation as required.
- The discussion, debate and decision making at a formal meeting is typically managed by an elected or appointed

chairperson who grants or withholds recognition to a delegate or delegation wishing to make an **intervention**, an oral statement of fact or opinion and/or a question to the chairperson of the meeting or to another delegate through the chairperson. In large multilateral meetings delegates are expected, out of courtesy, to limit their interventions and to make them brief so that all delegations have an opportunity to speak. Given that a chairperson, to be fair, usually “recognizes” delegations, i.e. calls upon them to speak, in the order in which they request that opportunity, and given that numerous interventions may occur between the time a delegation requests that opportunity and the time it is granted, multilateral discussions can be somewhat disjointed and discontinuous compared to bilateral discussions. During the discussion **minutes**, a chronological record of the discussion and actions of a meeting (but not a verbatim record) may be taken and subsequently provided to participants.

At the conclusion of each item on the agenda, the chairperson of a meeting often will summarize the results of the discussion of that topic and, if a decision is called for, determine whether a consensus exists or a vote is necessary. Decisions not made by consensus are likely to be made by a simple majority of votes cast, each delegation typically having a single vote. In certain specified circumstances established rules may require a qualified majority (e.g. two-thirds or three-fourths of the votes cast or some minimum number within a category of voters) to reach a decision. A decision by a meeting of an international body is likely to take the form of a resolution or recommendation and may be embodied in a report of the meeting. The decision(s) of a diplomatic conference may be set forth in a **final act**, a diplomatic conference document which includes the treaty or treaties and/or other agreements(s) reached.

**PROCESS WITHIN FORMAL
INTERNATIONAL ORGANIZATIONS**

An organization engaged multilaterally in some aspect of air transport regulation, whether as an intergovernmental or a non-governmental body and having a formal structure and staff, is likely to undertake several or all of the following basic, generically identified functions:

- supportive functions in advance of and during formal and informal meetings, such as the preparation of working papers and other documentation, translation and interpretation services as necessary and physical arrangements at the venue;
- relational functions with its members, the host State(s) in which its office(s) is/are located, potential members, other organizations, the public and communications media;
- continuous substantive functions, such as the collection and dissemination of data and the monitoring of relevant external activities;
- recurrent substantive functions, such as the preparation of annual reports;
- discrete substantive functions, such as undertaking non-recurrent studies;
- legal functions associated with organizational activities;
- administrative functions, such as those of personnel and finance; and
- associative functions or activities performed in support of or in association with other organizations.

**THE MULTILATERAL TREATY
PROCESS**

A treaty is typically the final product of a **diplomatic conference**, a meeting of sovereign States convened for the purpose of adopting a multilateral legal instrument (e.g. the Convention on International Civil Aviation, the International Air Services Transit Agreement, and other multilateral treaties). The meetings process involved in drafting a treaty is likely to be that described in the first section of this chapter, with some important variations, which include:

- the likelihood of there being a preparatory phase in which States, groups of States and other interested/affected parties seek to build a consensus on the purpose and basic outline of the contemplated treaty via a variety of means, including the use of diplomatic channels, bilateral and multilateral meetings and supportive activities within the international organization(s);
- the possibility of advance circulation of a draft text of the treaty (typically prepared by the international organization concerned) for the views and comments of States; and

- the probability that each delegation will have full powers.

The preparations and the strategic and tactical considerations involved are likely to be similar to those of the bilateral negotiating process.

Once the conference participants agree to the text of a draft treaty, the next step is adoption of the text by the representatives of all States present or by some agreed voting majority. This is followed by authentication of the text in one or more languages. The *authentication of the text of a treaty is usually done by the signature, signature ad referendum or initialling of the text (or of a final act of the conference which contains the text) by the representatives of the States attending the meeting who are so empowered. A signature ad referendum must be confirmed by the signer's State, for example, by that State's subsequent action of ratification of the treaty.*

The treaty itself may provide that it will enter into force or effect only after the deposit of a certain minimum number of *instruments of ratification, acceptance or approval, documents which formally express the consent of a State to be bound by a treaty. Acceptance or approval are ways by which a State that participated in the diplomatic conference but did not sign or initial the treaty may express its consent to be governed by it. An accession is the giving of the formal consent of a State, which did not participate in the drafting and adoption of a treaty, to be bound by it.* Accession can take place only if the treaty so provides or all the parties have agreed that consent to be bound may be expressed in such a way.

The *depository of a treaty, a State or international organization as stipulated in the treaty, assumes a responsibility to maintain the official record of which States are parties to a treaty and to inform other participating States when new expressions of consent to be bound by the treaty are deposited or other actions calling for such notification occur.* If the diplomatic conference at which the treaty was drafted was held under the auspices of a State or an international organization, that State or organization is likely to be named the depository.

A State, when signing, ratifying, accepting, approving or acceding to a treaty, may declare a *reservation, i.e. a statement indicating other than full acceptance of the treaty, which has the effect of modifying, interpreting, or*

simply not applying certain provisions in so far as the reserving State is concerned. A treaty may prohibit reservations, may provide that only specified reservations may be made, or may not provide for reservations. A reservation should not be incompatible with the object and purpose of the treaty. The treaty may require acceptance of any reservation by other parties, either tacit or explicit.

All of the above can occur at any time after the text of a treaty has been adopted. A treaty may also be applied provisionally pending its entry into force if this is provided for in the treaty or is otherwise agreed by the parties. Sometimes, it may take a long time for a treaty or an amendment to a treaty to enter into force because of the difficulty in obtaining the requisite number of ratifications.

Once a treaty has entered into force a copy is sent to the United Nations Secretariat for registration or filing and recording. An aviation-related treaty involving any ICAO Contracting State is required to be registered with the Council of ICAO.

The most fundamental action in the treaty process is that of observance by the parties of what they have agreed. The international law principle of *pacta sunt servanda means that every treaty in force is binding upon the parties to it and must be performed by them in good faith.* Other actions in the treaty process may include interpretation of the terms of the treaty and dispute resolution, each undertaken by the means provided for it under the treaty.

Once in force, a treaty may be changed in two ways. A *modification to a treaty is a change to it brought about when certain of the parties conclude an inter se agreement, i.e. an agreed alteration of some part of the application of the treaty solely as between those parties.* An *amendment to a treaty is a change to it, likely to be negotiated by all or most of the parties, that takes effect when an agreed number of parties have formally accepted it.*

There are essentially two ways for a State to cease being a party to a treaty. *Denunciation of a treaty is the giving of formal notice of withdrawal of consent to be bound by the treaty after the period of time provided for such action by the treaty.* *Withdrawal from a treaty by a party may take place with the consent of all the parties as a result of an occurrence such as a material breach, the impossibility of performance of a treaty obligation, or a fundamental change of circumstances affecting the party.*

Chapter 3.2

STRUCTURE OF MULTILATERAL REGULATION

The *structure of multilateral regulation* of international air transport *has*:

- *an organizational component consisting of a large and growing number of international organizations, including intergovernmental and non-governmental, worldwide and regional, trans-regional, formal and informal organizations; and*
- *a legal component embodied in multilateral treaties and similar instruments as well as relevant resolutions, recommendations and decisions of international organizations, both binding or non-binding on their members.*

The first section of this chapter discusses the basic elements of the organizational component of that structure that are generic to most international bodies.

The second section defines the basic generic terms used to identify the legal component of multilateral regulation.

The third section identifies the three principal multilateral instruments produced by the Chicago Conference.

The fourth section lists and briefly identifies the major components of the Warsaw System and the Montreal Convention of 1999.

The fifth section identifies other air law instruments related to air transport.

The final section identifies the principal regional multilateral agreements that regulate specific aspects of international air transport.

BASIC ELEMENTS OF THE ORGANIZATIONAL COMPONENT

An *international organization*, in the narrow meaning given in the Vienna Convention, is an *intergovernmental organization*, i.e. a body composed of two or more States, and in the broader idiomatic sense (used in the manual) means any organization having chiefly international activities and membership from more than one State, thus including the *non-governmental organization (NGO)*, a private body having international activities and membership (such as an association of air carriers from various States). An international organization can:

- be a formal one, with some written constitutional arrangement, or an informal one;
- have membership criteria, responsibilities and privileges;
- be worldwide, regional or *trans-regional* (i.e. less than worldwide but not confined to a single region);
- have or not have a headquarters;
- have or not have other than headquarters offices;
- have or not have a *secretariat*, a staff working within an established organizational structure in support of the organization;
- have a *sovereign body*, such as an assembly or a general membership meeting, however titled, which is convened regularly or at an agreed time and constitutes the final authority of the organization, setting its policy and conducting its business;

- have or not have a **governing body**, a group which directs and carries out the work of the organization when the sovereign body is not in session; and
- have or not have subsidiary bodies or advisory bodies on a standing basis, or special bodies to serve ad hoc purposes, usually set forth in **terms of reference**, i.e. an approved statement of the goals, objectives, tasks and constraints or limitations of the endeavour.

**BASIC TERMINOLOGY OF THE
LEGAL COMPONENT**

The most basic term in the legal component of the structure of multilateral regulation is “treaty”. The word **treaty**:

- is defined in the Vienna Convention on the Law of Treaties as “an international agreement concluded between States in written form and governed by international law, whether embodied in a single instrument or in two or more related instruments and whatever its particular designation” (the **Vienna Convention on the Law of Treaties**, which came into force on 27 January 1980 and is widely but not universally accepted, is a primary source of international law applicable to treaties between States);
- is sometimes designated as an **act, agreement, arrangement, charter, convention, covenant, declaration, final act or protocol**;
- in the broadest meaning of the term, is any written international agreement concluded between two or more States, even an exchange of letters or a memorandum of understanding; and
- in a more narrow meaning, designates only the most formal (and typically multilateral) agreements, particularly those which require ratification.

A multilateral treaty is likely to be structured to include:

- a preamble which typically expresses the underlying reasons for, and aims and objectives of, the treaty;
- a main body (which may be divided into several parts) having sequentially numbered articles which

provide definitions, substantive content (i.e. particular agreed rights and obligations) and modalities for the entry into force and continued operation of the treaty itself; and

- possible annexes and/or accompanying related documents forming part of the treaty.

While some form of treaty is the intended decisional output of a diplomatic conference, the decisional output of a formal meeting of an international organization is likely to be:

- a **resolution**, which is a formal expression of the collective opinion or will of an international organization, having a binding character, typically concerned with a single topic and including **preambular clauses** (typically beginning with “whereas”) which explain the background, circumstances and reasons for the decisions found in the subsequent **resolving clause(s)**, which set forth the decision(s) reached by the meeting; or
- a **recommendation**, which refers to an action which is advisory in nature rather than one having any binding effect; or
- a decision in some other form customarily used by the international organization.

Certain Latin words are used without translation in various international treaties, agreements and other regulatory contents. Those most frequently encountered, but not defined elsewhere, include:

- **a posteriori** — based on observation or experience, for example, a review of the progress achieved in implementing a particular regulatory arrangement (see also *ex post facto*);
- **a priori** — before examination or analysis, or before actual experience, for example, an *a priori* decision taken without first gaining actual experience with that activity;
- **ab initio** — from the beginning, for example, the discussion of a regulatory topic restarted from the beginning;
- **bis** — literally means *twice or second*, used to insert a new provision without affecting the

subsequent numbering, for example, Article 83 *bis* of the Chicago Convention inserted between Article 83 and Article 84;

- **de facto** — *in actual fact but not by legal establishment or official recognition*, for example, an air service being offered but not yet lawfully approved;
- **de jure** — *by law, lawful, legally established*, for example, a fully licensed and approved air service;
- **de minimus** — *very small*, for example, too minor to be included in a treaty text;
- **ex parte** — *on, or in the interests of one side only*, for example, an *ex parte* representation regarding a regulatory proceeding, *or by an interested non-party*, for example, by a non-governmental organization regarding the negotiation of a treaty;
- **ex post facto** — *after the fact*, for example, a bilateral review of the capacity offered and traffic carried on an agreed air route (see also *a posteriori*);
- **inter alia** — *among other things*;
- **mala fide** — *bad faith*;
- **mutatis mutandis** — *with the necessary changes being made*, for example, to adapt the terms of a multilateral arrangement clause for use in a bilateral clause;
- **per se** — *as such, by itself*;
- **prima facie** — *at first sight, before further examination*, for example, an initial interpretation of a treaty based on what it appears to say (that may later be contradicted and overcome by other evidence such as the negotiating record);
- **status quo** — *as things are*;
- **status quo ante** — *as things were* (before some event); and
- **suo moto** — *in its own way*.

**THE CHICAGO CONFERENCE
DOCUMENTS**

The Chicago Conference, held from 1 November to 7 December 1944, produced, *inter alia*, three major agreements of significance to the multilateral regulation of international air transport, the most important being the **Convention on International Civil Aviation**, signed at Chicago on 7 December 1944, also known simply as the **Chicago Convention** (Doc 7300), which provides the fundamental legal foundation for the regulation of world civil aviation, is the constitution of ICAO, and contains several articles which bear on the economic regulation of international air transport including:

- Article 1 on State sovereignty over airspace;
- Article 5 on non-scheduled flight;
- Article 6 on scheduled air services;
- Article 7 on cabotage;
- Article 15 on airport and similar charges;
- Articles 17 to 21 on nationality and registration of aircraft;
- Article 22 on facilitation;
- Articles 23 and 24 on customs and immigration;
- Articles 37 and 38 in so far as standards and recommended practices regarding facilitation are concerned;
- parts of Article 44 on the aims and objectives of ICAO;
- Articles 77 to 79 on joint operating organizations;
- Articles 81 and 83 on the registration of agreements; and
- Article 96 on air transport related definitions.

Two amendments to the Chicago Convention, which are of air transport regulatory significance, are **Article 83 bis**

which allows the transfer of certain functions and duties from a State of registry of an aircraft to the State of the operator in case of lease, charter, or interchange, and **Article 3 bis** which reconfirms the prohibition against the use of weapons against civil aircraft in flight and sovereignty over airspace.

The other two Chicago Conference documents of importance to the multilateral regulation of international air transport are:

- the **International Air Services Transit Agreement** (Doc 7500; also reproduced in Doc 9587), also known as the **Two Freedoms Agreement**, which provides for the multilateral exchange of rights of overflight and non-traffic stop for scheduled air services among its Contracting States; and
- the **International Air Transport Agreement** (reproduced in Doc 9587), also known as the **Five Freedoms Agreement**, which established five freedoms of the air for scheduled international air services but had no provisions on fair competition or for the regulation of capacity or fares and rates and came into force for nineteen States, eight of which subsequently denounced it.

**THE WARSAW SYSTEM AND THE
MONTREAL CONVENTION OF 1999**

The **Warsaw System**, a group of air law documents, governs air carrier liability with regard to passengers and consignees, and includes:

- the **Warsaw Convention**,¹ which is in force and unified the rules concerning the documents of carriage and the liability of air carriers;
- **The Hague Protocol**,² which is in force and substantially redrafted, modernized and simplified the rules relating to the documents of carriage as well as doubled the limit of carrier liability (specified in the Warsaw Convention) with respect to persons;
- the **Guadalajara Convention**,³ which is in force and extended the application of the Warsaw Convention to the carrier actually performing the

transport by air when a passenger or shipper contracted with a charterer or freight forwarder;

- the **Guatemala City Protocol**,⁴ which is not yet in force and would, inter alia, subject the carrier to strict liability regardless of fault, with respect to personal injury and damage and destruction or loss of baggage;
- the **Additional Protocol No. 1**,⁵ which is in force and replaces the “gold clause” by the **Special Drawing Rights (SDR)** (i.e. a kind of international money created by the International Monetary Fund (IMF) to supplement the use of gold and hard currencies in settling international payment imbalances), without increasing the actual limits of liability specified in the original Warsaw Convention (gold having been demonetized and no longer being an objective, reliable and stable yardstick of value);
- the **Additional Protocol No. 2**,⁶ which is in force and replaces the gold clause by the SDR, without increasing the actual limits of liability specified in The Hague Protocol;
- the **Additional Protocol No. 3**,⁷ which is not yet in force and would also replace the gold clause by the SDR, without increasing the actual limits specified in the Guatemala City Protocol; and
- the **Montreal Protocol No. 4**,⁸ which is in force and further amends the Warsaw Convention as Amended at The Hague, 1955, in respect of postal items and of cargo, by simplifying cargo documentation, introducing strict liability for cargo, and replacing its currency unit by the SDR, without increasing the actual limits of liability (specified in The Hague Protocol).

The so-called **Montreal Agreement of 1966**, which is not an international agreement but only an arrangement regarding the liability among the air carriers operating passenger transport to, from, or with an agreed stopping place in the United States, was adopted by the then-Civil Aeronautics Board of the United States on 13 May 1966 and followed by a withdrawal of the denunciation of the Warsaw Convention by the United States which was to take effect on 16 May 1966. By this agreement, the parties thereto have de facto amended the application of the Warsaw Convention as amended at The Hague (1955) by providing for a limit of liability for each passenger in the case of death or bodily

injury of U.S.\$75 000 inclusive of legal fees and costs and U.S.\$58 000 exclusive of legal fees and costs.

The **Montreal Convention of 1999**⁹, which enters into force on 4 November 2003, in effect, modernizes and consolidates all Warsaw System instruments, and prevails over all Warsaw System instruments, as between two States both Parties to the Convention. As between two States not both Parties to the Convention, the relevant Warsaw System instruments will remain in effect, if such States are both Parties thereto. This Convention enhances the rights of claimants in cases involving the death or injury of passengers engaged in international air travel.

The relationships between the conventions and protocols comprising the Warsaw System/Montreal Convention of 1999, as well as the limits of liability for the air carriers, can be seen in Figure 3.2-1. Further information on the Warsaw System and the Montreal Convention may be obtained from the Legal Bureau of ICAO.

OTHER AIR LAW INSTRUMENTS

Other international air law regulatory documents which affect international air transport include:

- the **Geneva Convention**,¹⁰ which is in force and recognizes various rights in aircraft (property, acquisition, possession, etc.);
- the **Rome Convention**,¹¹ which is in force and entitles any person who suffers damage on the surface caused by an aircraft in flight or by any person or thing falling from the aircraft to claim just compensation;
- the **Tokyo Convention**,¹² which is in force and establishes jurisdiction of the State of registration of the aircraft over offenses and acts that do or may endanger the safety of the aircraft in flight or of persons or property therein;
- **The Hague Convention**,¹³ which is in force and originated the concept of universal jurisdiction over unlawful acts of seizure or exercise of control of aircraft in flight (hijacking) and obliges Contracting States to institute proceedings against such acts;

- the **Montreal Convention**,¹⁴ which is in force and expands the concept of unlawful acts to offences against aircraft in service, air navigation facilities and the safety of civil aviation in general;
- the **Protocol Supplementary to the Montreal Convention of 1971**,¹⁵ which is in force and is aimed at suppressing acts of violence at international airports that endanger or are likely to endanger the safety of persons or the safe operation of such airports; and
- the **Convention on the Marking of Plastic Explosives for the Purpose of Detection**,¹⁶ which is in force and is intended to prevent unlawful acts against aircraft undertaken by the use of plastic explosives.

REGIONAL MULTILATERAL AGREEMENTS

Although States have not succeeded in reaching a globally acceptable multilateral agreement for the exchange of commercial air transport rights, certain regional multilateral intergovernmental agreements and arrangements have been developed to regulate specific aspects of international air transport. They include, in a chronological order:

- the **Multilateral Agreement on Commercial Rights of Non-scheduled Air Services in Europe** concluded by the European Civil Aviation Conference (ECAC) member States, signed at Paris on 30 April 1956, which established a policy that aircraft engaged in non-scheduled commercial flights within Europe which do not harm their scheduled services may be freely admitted;
- the **International Agreement on the Procedure for the Establishment of Tariffs for Scheduled Air Services**, signed at Paris on 10 July 1967, which provided ECAC member States with uniform principles and procedures regarding tariff establishment and supported the IATA conference machinery;
- the **Multilateral Agreement on Commercial Rights of Non-scheduled Air Services among the Association of South-East Asian Nations (ASEAN)**, signed at Manila on 13 March 1971, which liberalized non-scheduled air services within the subregion;

- the **International Agreement on the Procedure for the Establishment of Tariffs for Intra-European Scheduled Air Services** by ECAC member States, signed at Paris on 16 June 1987, which provided uniform principles and procedures for the establishment of tariffs and introduced the zone system of tariff regulation;
- the **International Agreement on the Sharing of Capacity on Intra-European Scheduled Air Services** by ECAC States, signed at Paris on 16 June 1987, which provided uniform principles and procedures for the sharing of capacity on intra-European scheduled services and introduced a zonal scheme of capacity sharing;
- the **Yamoussoukro Declaration on a New African Air Transport Policy**, signed by the ministers for civil aviation of African States in October 1988 and revised in September 1994, which established a programme for the integration of African airlines and guidelines for cooperation in the air transport field among States in Africa;
- **Decision 297 of the Commission on the Cartagena Accord** to implement the Act of Caracas, signed in May 1991 and approved by the presidents of the five Andean Pact countries (Bolivia, Colombia, Ecuador, Peru and Venezuela), which established an “open skies” air transport arrangement for this subregion;
- the **Multilateral Agreement Concerning the Operation of Air Services within the Caribbean Community (CARICOM)**, commonly called the **CARICOM Multilateral Air Services Agreement (MASA)**, which was concluded on 6 July 1996 by 11 of its 14 member States and entered into force in November 1998;
- the **Fortaleza Agreement**, signed on 17 December 1996, which liberalized intra-regional air services over routes not under bilateral agreements among the four MERCOSUR States and their two associate member States;
- the **Banjul Accord for an Accelerated Implementation of the Yamoussoukro Declaration**, commonly called the **Banjul Accord**, signed by Ghana, Gambia, Guinea, Nigeria and Cape Verde, in 1997, which liberalized air services between each State;
- the **Agreement Among Directors General of Civil Aviation of the Kingdom of Cambodia, the Lao People’s Democratic Republic, the Union of Myanmar, and the Socialist Republic of Viet Nam on the Establishment of Subregional Air Transport Cooperation**, commonly called the **CLMV Agreement**, concluded 15 January 1998, by Cambodia, Lao People’s Democratic Republic, Myanmar and Viet Nam, which established a sub-regional cooperation regime aimed at achieving air transport liberalization;
- the **COMESA Agreement** among the 21 member States of the Common Market for Eastern and Southern Africa (COMESA), which moved them in 1999 from the full liberalization of cargo services in the first phase of their air services liberalization programme to the second phase of liberalization involving passenger service;
- a phased programme for the liberalization of air services between members of the Arab Civil Aviation Commission (ACAC), which was finalized in 2000 and envisages full liberalization of air services amongst member States by 2005;
- the **Multilateral Agreement on the Liberalization of International Air Transportation**, also known as the **Kona Agreement**, signed on 1 May 2001 by Brunei Darussalam, Chile, New Zealand, Singapore and the United States, which is a plurilateral open skies arrangement among the signatory parties and which is open for accession by any APEC members as well as other States (Peru and Samoa subsequently adhered to the Agreement); and
- the **Protocol to the Multilateral Agreement on the Liberalization of International Air Transportation**, signed on 1 May 2001 by Brunei Darussalam, New Zealand and Singapore, which provides for the exchange of cabotage and so-called “Seventh Freedom” rights;
- a **Multilateral Air Services Agreement for Liberalization among States of the Pacific Islands Forum**, endorsed in August 2003 by the Leaders of the Forum States, which provides for phased liberalization of air services among Parties to the Agreement and is open for conditional accession by other non-member States.

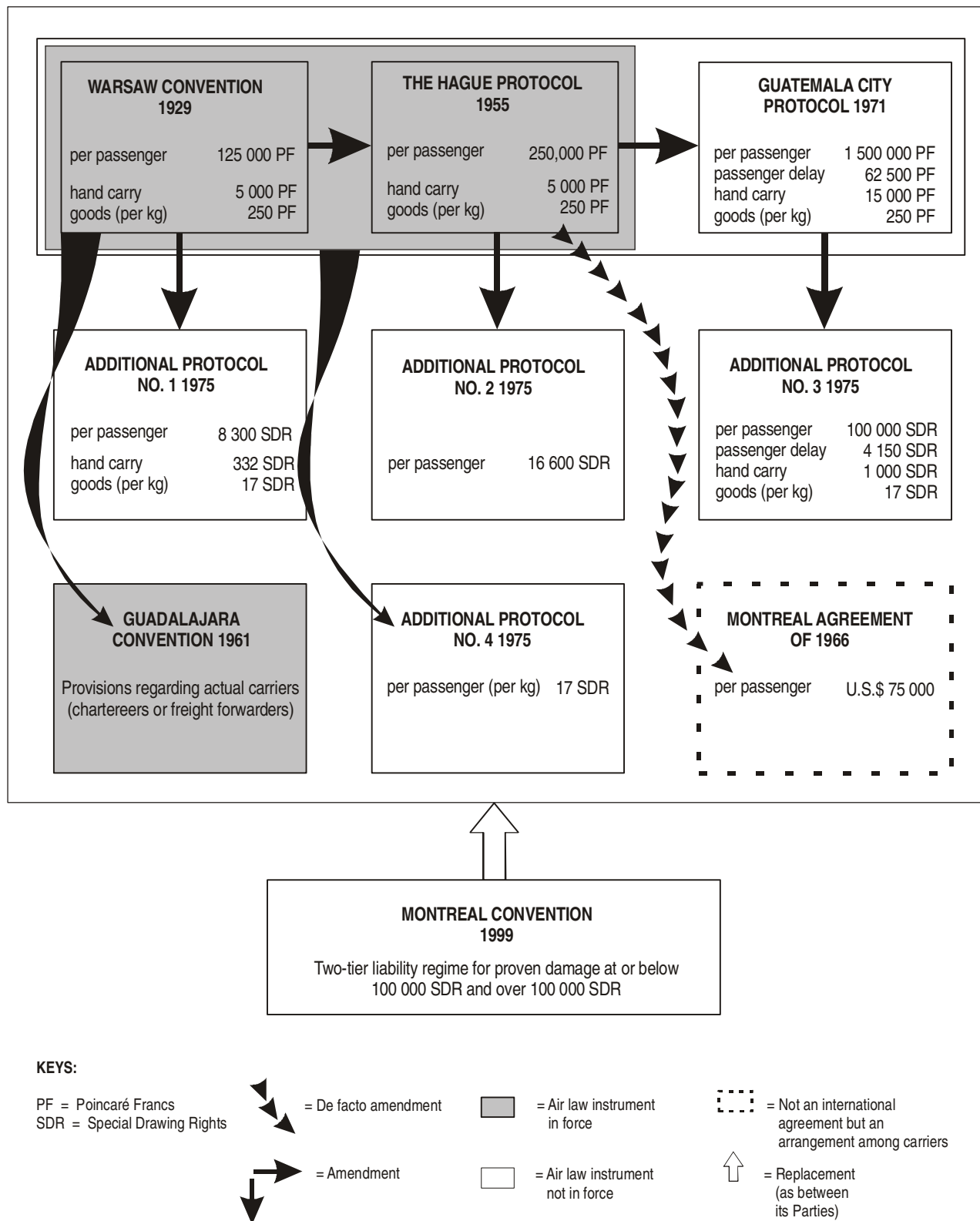

Figure 3.2-1. The Warsaw system, the Montreal Convention of 1999, and the limits of carrier liability

NOTES

1. Convention for the Unification of Certain Rules Relating to International Carriage by Air signed at Warsaw on 12 October 1929.
2. Protocol to Amend the Convention for the Unification of Certain Rules Relating to International Carriage by Air Signed at Warsaw on 12 October 1929, signed at The Hague on 28 September 1955 (Doc 7632).
3. Convention, Supplementary to the Warsaw Convention, for the Unification of Certain Rules Relating to International Carriage by Air Performed by a Person Other than the Contracting Carrier, signed at Guadalajara on 18 September 1961 (Doc 8181).
4. Protocol to Amend the Convention for the Unification of Certain Rules Relating to International Carriage by Air Signed at Warsaw on 12 October 1929 as Amended by the Protocol Done at The Hague on 28 September 1955, signed at Guatemala City on 8 March 1971 (Doc 8932).
5. Additional Protocol No. 1 to Amend the Convention for the Unification of Certain Rules Relating to International Carriage by Air Signed at Warsaw on 12 October 1929, signed at Montreal on 25 September 1975 (Doc 9145).
6. Additional Protocol No. 2 to Amend the Convention for the Unification of Certain Rules Relating to International Carriage by Air Signed at Warsaw on 12 October 1929 as Amended by the Protocol Done at The Hague on 28 September 1955, signed at Montreal on 25 September 1975 (Doc 9146).
7. Additional Protocol No. 3 to Amend the Convention for the Unification of Certain Rules Relating to International Carriage by Air Signed at Warsaw on 12 October 1929 as Amended by the Protocols Done at The Hague on 28 September 1955 and at Guatemala City on 8 March 1971, signed at Montreal on 25 September 1975 (Doc 9147).
8. Montreal Protocol No. 4 to Amend the Convention for the Unification of Certain Rules Relating to International Carriage by Air Signed at Warsaw on 12 October 1929 as Amended by the Protocol Done at The Hague on 28 September 1955, signed at Montreal on 25 September 1975 (Doc 9148).
9. Convention for the Unification of Certain Rules for International Carriage by Air, done at Montreal on 28 May 1999 (Doc 9740).
10. Convention on the International Recognition of Rights in Aircraft, signed at Geneva on 19 June 1948 (Doc 7620).
11. Convention on Damage Caused by Foreign Aircraft to Third Parties on the Surface, signed at Rome on 7 October 1952 (Doc 7364).
12. Convention on Offences and Certain Other Acts Committed on Board Aircraft, signed at Tokyo on 14 September 1963 (Doc 8364).
13. Convention for the Suppression of Unlawful Seizure of Aircraft, signed at The Hague on 16 December 1970 (Doc 8920).
14. Convention for the Suppression of Unlawful Acts against the Safety of Civil Aviation, signed at Montreal on 23 September 1971 (Doc 8966).
15. Protocol for the Suppression of Unlawful Acts of Violence at Airports Serving International Civil Aviation, Supplementary to the Convention for the Suppression of Unlawful Acts against the Safety of Civil Aviation, Done at Montreal on 23 September 1971, signed at Montreal on 24 February 1988 (Doc 9518).
16. Convention on the Marking of Plastic Explosives for the Purpose of Detection, done at Montreal on 1 March 1991 (Doc 9571).

Chapter 3.3

KEY ISSUES OF MULTILATERAL REGULATORY PROCESS AND STRUCTURE

The key issues of multilateral regulatory process and structure are long-standing ones which focus on whether to seek, and how to achieve, a viable multilateral agreement or agreements (either worldwide or trans-regional) to supplant or supplement bilateral air transport agreements. (These issues are distinct from those of regulatory arrangements within regional economic communities of States whose memberships are limited geographically and whose internal structures and processes regulate other activities in addition to air transport.) ICAO Assembly Resolution A33-19 (in force) states that "... multilateralism in commercial rights to the greatest possible extent continues to be an objective of the Organization."

The first section of this chapter presents arguments for and against seeking multilateral air transport regulation. The next section explores possible negotiating processes that might be used to seek a multilateral agreement. The third section identifies likely generic structural elements of such an agreement. A final section discusses the General Agreement on Trade in Services and its Air Transport Annex, an attempt at multilateral regulation outside any traditional framework.

WHY THE MULTILATERAL APPROACH?

The arguments favouring and those opposing multilateral international air transport regulation both focus upon its adaptation to broader economic phenomena, and its relative efficiency compared to bilateralism.

The favouring arguments related to adaptation to broader economic phenomena include:

- that air transport is a service industry increasingly affected by the same forces changing other service industries (i.e. the privatization of, and foreign equity holdings in, national companies; inter-company alliances aimed at global market access; and regulatory liberalization), yet it remains separately and differently regulated from such other service industries in ways which retard the air transport industry's growth;
- that air transport does not require distinctive regulation because, having developed, it is no longer an "infant" or entirely "special" industry;
- that the bilateral bartering process tends to reduce the opportunities available to the level considered acceptable by the least competitive and most restrictive party, thus bilateral air agreements are increasingly seen by entrepreneurial airline managements as imposing unacceptable restrictions on industry development;
- that air transport users, airports and airlines deserve to be freed from the constraints of bilateral air transport regulation (which can sometimes hamper the development of tourism and trade); and
- that such freedom can best be achieved by multilateralism, which can aggregate gains and offset constraints more easily than could a series of bilateral agreements and thus is gaining increased recognition as a better vehicle than bilateralism for achieving widespread liberalization.

The favouring arguments which focus on relative efficiency maintain that multilateralism could:

- rapidly create many new bilateral air service relationships within a single multilateral framework as each new party joined the multilateral arrangement without having to negotiate bilaterally with existing parties to the agreement;
- thus end the waste of time and the expense of negotiating and renegotiating a large number of bilateral air agreements, a process which strains the development of the air transport system;
- achieve more objective results (in particular as regards market access) than numerous bilateral negotiations because the outcome of bilateral negotiations can be affected by the subjective circumstances of differing negotiating capabilities and bargaining leverage of the parties;
- end incompatibilities in market access conditions which now complicate or preclude various multi-stop route operations; and
- further promote increased standardization of numerous regulatory arrangements included in bilateral air service agreements (on matters such as customs exemptions, aviation security, and currency conversion and remittance).

The opposing arguments related to adaptation to broader economic phenomena include:

- that multilateral air transport agreements are not needed because bilateralism has been used successfully to achieve the liberalization of air services between partner States wishing to liberalize;
- that advocates of multilateralism are mistaken in believing that because it is likely to be very difficult under a multilateral agreement to limit access to individual bilateral markets (for example, in order to seek some balance of benefits), such limitations would necessarily be excluded;
- that if a liberal multilateral air transport agreement is achieved with few limitations it would most likely favour large and well-established airlines, advancing their interests against those of airlines of the developing countries (which may not be sufficiently helped to ensure their continued international presence), thus threatening the continuing access of such countries to adequate air services; and

- that apart from the concerns it raises, multilateralism is simply not feasible in the foreseeable future in the absence of a broader consensus.

The opposing arguments related to relative efficiency maintain that multilateralism:

- inherently tends toward a “least common denominator” result which could reduce the scope and effectiveness of any agreement;
- is less flexible because a revision to a multilateral agreement is much more difficult to achieve than that to a bilateral agreement (it requires not two, but numerous parties to be motivated to bring it about);
- prevents States from tailoring each regulatory arrangement to individual bilateral situations; and
- lessens the ability of a State to protect a national air carrier or carriers by use of ad hoc and micro-level bilateral controls.

The supporters of continued bilateralism also tend to point out that international air traffic has grown at a prodigious rate under bilateralism and that bilateralism has not inhibited technological and marketing innovations such as the introduction of jet aircraft and computer reservation systems.

Whether or not to pursue, or to support the pursuit of, some kind of multilateral air transport agreement entails weighing the above (and possibly other) arguments (noting that some on both sides are conjectural) in conjunction with an exploration of the possible multilateral processes and the likely structural components involved.

**POSSIBLE PROCESSES
IN THE QUEST FOR A
NEW MULTILATERALISM**

The traditional and other processes that might be used in an attempt to reach some new multilateral agreement(s) or arrangement(s) to regulate international air transport include:

- a worldwide diplomatic conference to negotiate and draft a multilateral agreement; or
- a conference of “like-minded” States at which a multilateral agreement, presumably one open to

accession by non-participating States, would be negotiated and drafted by participating parties; or

- a State-to-regional body or a regional body-to-regional body negotiation to produce an agreement between them designed to be open to accession by third parties; or
- a negotiation and drafting of some form of comprehensive multilateral air transport agreement under non-air transport (presumably trade) auspices.

Each of these possible processes presents difficult and as yet unresolved problems:

- successful worldwide diplomatic conferences require some broad advance consensus on the goals to be sought and the means to achieve them, a consensus not yet evident in this field;
- a “like-mindedness” sufficient to bring together any substantial number of States from different regions of the world to seek a new agreement has yet to be demonstrated (given the disparity of national conditions and the need for each State to act in its national interest, an interest which is rarely if ever identical to that of any other State);
- a process by which a regional body can formulate a common negotiating position and carry out, as a unit, a bilateral negotiation with a second party, can be a very difficult one to establish and can tend to raise legitimate concerns among smaller States and uninvited or otherwise non-participating parties that their interests could be prejudiced; and
- a non-air transport forum (the Group of Negotiations on Services under GATT auspices) explored a broad multilateral agreement to include air transport market access rights but failed to find more than minimal support largely due to proposed mandatory (but not necessarily reciprocal) most-favoured nation treatment.

Some preliminary process of very detailed analysis and design (at an expert level) of the essential elements of a comprehensive multilateral regulatory structure, carried out over a period of time longer than typically devoted to a conference, could conceivably develop certain potentially viable regulatory arrangements. If such arrangements were to have sufficient tentative acceptability, they could bring about a consensus sufficient to begin one or more of the above negotiating and drafting processes.

**THE LIKELY GENERIC
STRUCTURAL ELEMENTS OF A
NEW MULTILATERAL
AIR TRANSPORT AGREEMENT**

The structure of a new multilateral arrangement could theoretically be that of a traditional multilateral treaty: it would enter into effect only when a predetermined number of instruments of ratification, acceptance or approval by the States that negotiated the agreement were deposited; it could be amended only by approval of a pre-agreed number of parties; it could provide for limited reservations and for accessions by other States; etc. Alternatively, the structure could: take a non-traditional form; enter into effect (between consenting parties) when as few as two instruments of ratification, acceptance or approval were deposited; have flexibility sufficient to minimize the need for amendments; provide for the application of amendments as accepted by each party; provide for accessions by other States; etc.

The principal objective of such an agreement presumably would be liberalization; however, it could have additional objectives such as increasing the participation of developing countries and achieving greater regulatory efficiency. The agreement could be oriented towards immediate liberalization, towards progressive liberalization or possibly to accommodate both liberalization and some aspects of more traditional regulation. It could be designed with consideration of the needs of air transport users and workers, of airports and their communities, and of tourism and trade interests as well as those of airlines and their regulators.

A question fundamental to the design of the new agreement would be whether it would replace existing bilateral arrangements or complement them. If the multilateral agreement were to complement bilateral agreements, the question would arise of how such a hybrid regime would work.

A multilateral agreement could:

- include both scheduled and non-scheduled air services between the parties;
- cover only scheduled or only non-scheduled air services between the parties;
- cover only certain traffic, initially or long term, i.e. only passengers or only freight and mail, or could cover both;

- include market access (route, traffic and operational rights) possibly subject to further bilateral understanding, but not necessarily access to all markets (e.g. the drafters might exclude so-called Seventh Freedom and exclude or limit cabotage rights); and
- very likely would include some regulatory arrangements specifically for use by a party when and if ever needed to respond to actions deemed contrary to the aims and terms of the agreement.

In addition to requiring much innovative work in order to express, in a multilateral context, some kind and level of (presumably liberalized) regulation of the principal matters of bilateral concern (chiefly market access rights, capacity, tariffs and commercial considerations), a new multilateral structure may possibly:

- employ or adapt the language used in the ICAO template air services agreement (TASA, contained in Doc 9587);
- employ or adapt some or many elements of multilateral agreements that are in effect (e.g. the Kona Agreement) or proposed (such as the model Multilateral Agreement for the Liberalization of Air Cargo Services developed by the OECD Secretariat);
- employ, and perhaps adaptively improve upon, some concepts and approaches used, or proposed to be used, in trade agreements (as explained in the following section of this chapter);
- introduce new dispute resolution approaches not traditionally found in bilateral air transport agreements; and
- include provisions for the possible collective consent by States acting as a regional unit.

**THE GENERAL AGREEMENT ON
TRADE IN SERVICES (GATS) AND
ITS AIR TRANSPORT ANNEX**

The *General Agreement on Trade in Services (GATS)*, produced by the *Group of Negotiations on Services (GNS)* (a group of Contracting Parties set up by the GATT for this purpose during the Uruguay Round), entered into effect on 1 January 1995 and applies various trade principles and practices to certain services including, in an Annex, certain

air transport services, a departure from their traditional frameworks for regulation. At this writing, the GATS Annex on Air Transport Services excludes traffic rights, however granted, and services directly related to the exercise of traffic rights, with exceptions for three soft rights:

- 1) **aircraft repair and maintenance services**, meaning such activities when undertaken on an aircraft or a part thereof while it is withdrawn from service; these activities do not include so-called line maintenance;
- 2) **selling and marketing of air transport services**, meaning opportunities for the air carrier concerned to sell and market freely its air transport services including all aspects of marketing such as market research, advertising and distribution; these activities do not include the pricing of air transport services nor the applicable conditions; and
- 3) **computer reservation system (CRS) services**, meaning services provided by computerized systems that contain information about air carriers' schedules, availability, fares and fare rules, and through which reservations can be made or tickets may be issued.

The Annex further provides that the dispute settlement procedures of the Agreement may be invoked only where obligations or commitments have been assumed by the parties concerned and where dispute settlement procedures in bilateral and other multilateral arrangements have been exhausted. It also confirms that any specific commitment or obligation assumed under the Agreement will not reduce or affect a party's obligations under bilateral or multilateral agreements that are in effect at the entry into force of the Agreement establishing the World Trade Organization (see Chapter 3.7). It also requires the Council on Trade in Services to "review periodically, and at least every five years, developments in the air transport sector and the operation of the Annex with a view to considering the possible further application of the Agreement in this sector." (The first review of the Annex began in 2000.)

The GATS itself, under which the Annex on Air Transport Services functions, identifies four *modes of supply* or *different ways services can be supplied in markets that are foreign to the supplier*, namely:

- **cross-border**, i.e. the supply of a service from the territory of one Party to the territory of another Party (such as international flights or telephone calls). This does not require the supplier of the first Party to be admitted to the territory of the second Party, only the service itself crosses national borders;

- **consumption abroad**, *i.e. the supply of a service in the territory of one Party to the service consumer of any other Party*. Typically this involves the consumer travelling to the supplying country, for example, for tourism or study. Repair of aircraft outside its home country is another example;
- **commercial presence**, *i.e. the supply of a service through the commercial presence of the foreign supplier in the territory of another Party* (e.g. an airline ticket office, a subsidiary or branch office to deliver such services as banking or legal advice); and
- **presence of a natural person**, *i.e. the supply of a service through the presence of foreign nationals or individuals in the territory of another Party* (e.g. a lawyer, doctor, architect).

The focus of the GATS is on liberalization. There are three **GATS core liberalization principles**, those of:

- **market access** or specification of the levels of access to be granted other parties through the four modes of supply;
- **national treatment**, *i.e. treatment of foreign services and suppliers of services no less favourable than that accorded a party's own services and service suppliers*; and
- **most-favoured nation (MFN) treatment**, *i.e. non-discrimination, the provision of treatment to all parties no less favourable than that accorded to any party*.

There is an important distinction between these principles. Market access and national treatment are **specific principles under the GATS**, *i.e. principles which each individual party can choose to apply or not apply to any particular service or aspect thereof under conditions and limitations contained in its specific commitment for that service*. In contrast, MFN is a **GATS general obligation**, *i.e. one applicable unconditionally to all services, including those for which a party has made no specific commitment to market access or national treatment*.

However, parties may make an exception to MFN for specific services by including that service in their exemption list. Thus, a party can vary the degree of its liberalization of a specific service by (1) filing an exemption from MFN for that service or (2) making specific commitments

for market access and national treatment, including any conditions and limitations. This can result in variations in the obligations of different parties with respect to the same service, a circumstance that critics charge results in **free riders**, *parties which enjoy liberalized access with regard to supplying a specific service in the territories of other parties without having to provide the same degree of liberalized access for that service in their own markets*. In response, those taking a broader view point out that liberalization with respect to other services by parties which are free riders tends to mitigate a lack of liberalization for a particular service with respect to certain parties. They also contend that, over time, progressive liberalization through future negotiations will result in the removal of MFN exemptions and additional specific commitments to market access and national treatment, making the free-rider phenomenon less frequent.

Other general obligations in the GATS include those of:

- **transparency**, *a requirement for prompt publication of all relevant rules and regulations, administrative guidelines and all other decisions, rulings, or measures of general application which pertain to or affect the operation of the Agreement* (except for certain confidential information the disclosure of which would impede law enforcement, or otherwise be contrary to the public interest, or which would prejudice the legitimate commercial interests of particular enterprises);
- **increasing participation of developing countries**, *to be achieved by improving their access to technology, distribution channels and information networks; by the liberalization of market access in sectors, and modes of supply, of export interest to them; and by taking particular account of the serious difficulty of the least-developed countries in accepting negotiated commitments*;
- not preventing (under certain circumstances) signatories from being a party to or entering into economic integration agreements which liberalize trade in services;
- ensuring that all measures of general application with respect to domestic regulation affecting trade in services, in sectors or subsectors where specific commitments are undertaken, are administered in a reasonable, objective and impartial manner;
- according recognition to licences or certification granted, or to education or experience obtained or

requirements met, in a particular country, without discrimination between countries in the application of its standards or criteria for the authorization, licensing or certification of service providers;

- ensuring that monopoly service providers in its territory comply with MFN and specific commitments on market access and national treatment; and
- not applying restrictions on international transfers and payments for current transactions relating to specific commitments under the GATS, except for restrictions to respond to serious balance-of-payments difficulties (which must be applied in a non-discriminatory manner to all parties).

A trade negotiation procedure in the GATS of possible use in a broad multilateral or plurilateral air transport

agreement is that of *offers and requests*, a procedure in which each party lists the services it is prepared to liberalize and those it wishes other parties to liberalize. Bilateral or multilateral parties modify their lists in terms of offers to secure from other parties liberalization of services which they have requested. The expansion of the offers lists of all parties reduces the lists of requests until parties are no longer prepared to make further changes in their list of offers.

Applying the basic GATS principle of MFN to traffic rights remains a complex and difficult issue. While there is some support to extend the GATS Annex on Air Transport Services to include some soft rights as well as some aspects of hard rights, there is no global consensus on whether or how this would be pursued. Whether the GATS is an effective option for air transport liberalization remains in question.

Chapter 3.4

INTERNATIONAL CIVIL AVIATION ORGANIZATION (ICAO)

The *International Civil Aviation Organization (ICAO)* is the worldwide intergovernmental organization created by the Convention on International Civil Aviation signed at Chicago on 7 December 1944 to promote the safe and orderly development of international civil aviation throughout the world (website: www.icao.int). A specialized agency of the United Nations, it sets international standards and regulations necessary for safe, regular, efficient and economical air transport and serves as the medium for cooperation in all fields of civil aviation among its 188 Contracting States (as of August 2003).

As with most intergovernmental organizations, policy is developed in multinational meetings of various kinds. This chapter deals only with those aspects relating to economic regulation. The first section identifies the various bodies of ICAO which, in their meetings, develop policy including that regarding the regulation of international air transport. It also explains how these bodies are organized (structure) and carry out their work (process).

Policy development typically requires a significant volume of preliminary research and analysis, the support of meetings of policy development bodies, and consequent implementation and monitoring of the decisions taken. The many related tasks involved for the Organization are largely undertaken by the *ICAO Secretariat*, a permanent organizational structure with staff recruited from the Contracting States of ICAO. The next section of this chapter identifies those parts of this structure which are involved in international air transport matters and describes their principal activities.

The activities of both the policy development bodies and the ICAO Secretariat produce policy, guidance and information for Contracting States. The final section of this chapter identifies the principal output of both the policy development bodies and the Secretariat which are related to international air transport regulation.

POLICY DEVELOPMENT BODIES

The *Assembly of Contracting States*, the sovereign body of the Organization, is convened by the ICAO Council once every three years. An extraordinary session may be called at any time by the Council or at the request of not less than one-fifth of the ICAO Contracting States.

The work of each Assembly is carried out by accredited delegations from the ICAO Contracting States. Each Contracting State has one vote in the Assembly and in its subsidiary bodies. The accredited persons register as delegates, alternates or advisers, with one person on each delegation being designated as the Chief Delegate. Observers from invited non-Contracting States and international organizations may participate in the deliberation in open sessions, without votes. Communications media representatives and the general public may also attend open meetings. Documentation used at an Assembly is provided in English, Arabic, Chinese, French, Russian and Spanish. Simultaneous interpretation is provided for these languages as well.

Each Assembly is opened by the President of the Council and meets in plenary sessions to: elect a president and various vice-presidents from among Contracting State delegations, adopt an agenda, establish various committees and commissions and elect their chairpersons, elect States to be Council members, review the work of the committees and commissions, and adopt resolutions to establish policy as well as a budget and work programme for the forthcoming triennium.

The *Economic Commission* is the subsidiary body which is generally established at each ordinary Session of the Assembly for discussion and resolution of economic issues (including those affecting regulation) in the field of international air transport. The Economic Commission

examines all matters referred to it, usually on the basis of working papers submitted by Contracting States, the Council, the Secretariat, or accredited observers, and submits reports on its work for consideration at plenary meetings of the Assembly.

The **Council** is the permanent governing body of ICAO responsible to the Assembly, composed of 36 Contracting States elected by the Assembly for a three-year term. It usually convenes for three sessions per year. The Council elects its President for a term of three years and three Vice-Presidents for a one-year term. The Secretary General of ICAO serves as the Secretary of the Council. Any Contracting State may participate, without a vote, in the consideration by the Council of any question which especially affects its interests.

The Council submits annual reports to the Assembly, carries out the directives of the Assembly, and discharges its duties and obligations as laid down in the Convention. In the air transport field, the Council implements relevant resolutions of the Assembly, adopts policy by Council resolutions and decides the tasks and priorities for the ICAO air transport work programme.

The **Air Transport Committee** is the standing subsidiary body of the Council which deals with air transport matters. The Committee is composed of representatives of the Council Member States who are appointed by the Council and act in their individual capacities. Its duties and obligations are defined by the Council pursuant to the Convention. The Committee elects its Chairperson and Vice-Chairpersons for a one-year term. The Director of the Air Transport Bureau of the Secretariat is the Secretary of the Air Transport Committee. Its meetings are frequently attended by the President of the Council and the Secretary General.

The Committee has three groups of meetings each year during the Committee phase of each Council session, typically a period of several weeks preceding the Council phase. Any Contracting State may participate, without a vote, in the consideration by the Committee of any question which especially affects its interests.

The work programme of the Committee for each session is decided by the Council. The Committee examines working papers and reports on its work to the Council whenever relevant. From time to time, the Committee also examines proposed changes to international standards and recommended practices in Annex 9 — *Facilitation* — to the Convention.

As the Committee is responsible to the Council, its role is essentially a recommendatory one. It serves as a sounding board for items on which a Council decision is necessary by allowing a free exchange of the personal viewpoints of members and detailed discussion of items.

Apart from diplomatic conferences and meetings of the ICAO bodies concerned with policy development in the air transport field, special worldwide meetings are convened, from time to time, by ICAO for the same purpose, at which each Contracting State can be represented.

An **air transport conference** is a special worldwide meeting held to discuss regulatory issues in the air transport field. (While it is at the same level as an air navigation conference, it does not share the same broad scope, since it does not encompass all air transport matters.)

A **divisional session** is a special worldwide meeting convened for the purpose of discussing issues in a specific area in the air transport field such as statistics or facilitation.

The agenda of a conference is normally approved by the Council and that of a divisional session by the Air Transport Committee. A special worldwide meeting may establish such committees, subcommittees and working groups as it may consider to be necessary or desirable. The Chairperson of a special worldwide meeting submits a report to the Council.

A **panel** is a group of qualified experts established to advance, within specified time frames or on a standing basis, the resolution of special problems which cannot be solved adequately or expeditiously by established ICAO bodies or the Secretariat. The deliberations and conclusions of a panel focus on the resolution of technical problems and are advisory in nature. When a panel is being formed, all Contracting States are invited to nominate members. Between 12 and 15 persons are typically chosen from among the nominees to be panel members.

In the air transport field, a panel may be established by the Council or by the Air Transport Committee (as were the **Airport Economics Panel**, the **Panel on Air Navigation Services Economics** and the **Air Transport Regulation Panel**).

When a panel is established, its terms of reference and work programme are set in order to define clearly and concisely the nature and scope of the work assigned to the panel, and to specify the objectives sought. A panel elects

its Chairperson and Vice-Chairpersons for each meeting and conducts its work in the ICAO working languages required by the participants. A Secretariat official serves as secretary of the panel. The Chairperson transmits the report of each panel meeting to the Air Transport Committee, which usually considers the report in conjunction with a Secretariat paper regarding action on the conclusions or recommendations reached.

A **Secretariat study group** is a less formal group appointed by the Secretary General to provide the Secretariat with outside assistance and expertise in carrying out a particular task (e.g. the **Study Group on Computer Reservation Systems (CRS)** established in 1987 to assist the Secretariat in undertaking studies relating to computer reservation systems). A study group differs from a panel in several respects: its function is to advise the Secretariat; a Secretariat official leads the discussion of a study group; meetings are usually conducted in a single language; and study group reports are submitted by the appointed Secretariat official.

AIR TRANSPORT BUREAU

The **Air Transport Bureau** of the ICAO Secretariat is responsible for the air transport programme of the Organization and aviation security and provides expertise and assistance on air transport matters to the various bodies and meetings of ICAO. More specifically, it is responsible for:

- the provision of expert assistance required by the Assembly, Council, Air Transport Committee, Joint Support Committee, Committee on Unlawful Interference and the specialized divisional, conference, panel, working and study group meetings that may be convened in the air transport field;
- the maintenance and amendment of the air transport and joint support work programmes, preparation of studies and documentation and the formulation of recommendations on these programmes for consideration, as appropriate, by the Air Transport Committee, Committee on Unlawful Interference or Joint Support Committee;
- the preparation of statistical digests and other statistical publications;

- the preparation and revision of manuals on aviation security, regulation of air transport services, airport and air navigation facility tariffs, route air navigation facility economics, airport economics, the ICAO statistical programme, and air traffic forecasting; preparation of documentation and meeting reports in the economic regulatory, statistical, aviation security, facilitation and joint financing fields; and preparation of annual publications of *The World of Civil Aviation* and Chapter I of the *Annual Report of the Council* which provide a worldwide survey of international civil aviation;
- the planning of periodic air transport meetings and the preparation of the agenda and supporting documentation; preparation, for publication, of approved amendments to Annex 9 — *Facilitation* and Annex 17 — *Security*, and the compilation and promulgation of lists of differences to these Annexes which are notified by Contracting States; provision of advice and assistance to States on implementation of these Annexes;
- the coordination of environment-related activities, both within the Secretariat and with other international organizations; and
- the coordination of the work of the regional civil aviation organizations with ICAO air transport programmes; and liaison and cooperation with international and regional organizations on air transport matters.

The Bureau also provides technical support and assistance to other Bureaux of the Organization and contributes to the Organization's work in multi-disciplinary areas such as environmental matters and the implementation of communications, navigation and surveillance/air traffic management (CNS/ATM) systems. The Director of the Air Transport Bureau serves as the Secretary to the Air Transport Committee.

Outside of ICAO's Montréal Headquarters, Air Transport Regional Officers are stationed at ICAO Regional Offices in Bangkok, Cairo, Dakar, Lima and Nairobi to provide assistance and expertise to the Contracting States to which each office is accredited and to the regional civil aviation bodies based in Dakar and Lima. They regularly attend meetings and conferences involving air transport as well as make periodic visits to Contracting States in their regions. They also provide liaison between ICAO Headquarters and those States on air transport matters.

<p>ICAO POLICY, GUIDANCE AND INFORMATION</p>

ICAO provides Contracting States with various published statements of its policy on international air transport regulatory matters, as developed or endorsed by the Assembly or the Council, as well as guidance materials and information developed by ICAO bodies or the Secretariat.

The ICAO publication entitled *Policy and Guidance Material on the Economic Regulation of International Air Transport (Doc 9587)* is a comprehensive reproduction of the conclusions, decisions and guidance material produced by ICAO on air transport which have received the endorsement of either the Assembly or the Council and are addressed to States or which directly impinge on the conduct by States of their air transport activities, and of Assembly Resolutions which are directed to ICAO as well as to States.

In addition to the present manual (Doc 9626), other relevant ICAO guidance material includes:

- *ICAO's Policies on Taxation in the Field of International Air Transport (Doc 8632)*, which contains the consolidated Council Resolution on taxation of international air transport, and an associated commentary;
- Statements by the Council, such as *ICAO's Policies on Charges for Airports and Air Navigation Services (Doc 9082)*, setting forth its recommendations and conclusions on these topics;
- definitions, such as the *definition of a scheduled international air service* (in Doc 9587) which, with notes on its application, provides guidance to Contracting States on the interpretation and application of the provisions of Articles 5 and 6 of the Convention;
- model clauses, such as those on capacity and tariff regulation found in Doc 9587;
- digests of information, such as the *Digest of Bilateral Air Transport Agreements (Doc 9511)*, a reference guide to the main provisions of existing bilateral agreements which Contracting States concluded or amended and filed with ICAO. A database of existing bilateral agreements is being prepared for release in CD ROM format;
- manuals, such as this manual and the *Manual on the ICAO Statistics Programme (Doc 9060)*, which is a guide for reporting and using ICAO civil aviation statistics, the *Manual on Air Traffic Forecasting (Doc 8991)*, which sets forth forecasting methods and case studies for civil aviation forecasters, the *Manual on Air Navigation Services Economics (Doc 9161)*, which provides guidance material to assist those responsible for the management of air navigation services and the *Airport Economics Manual (Doc 9562)*, which provides guidance to those responsible for airport management;
- studies, such as study on aircraft leasing and on the *Regulatory Implications of the Allocation of Flight Departure and Arrival Slots at International Airports (Cir 283)*; and
- State Letters, for the timely dissemination of information on particular topics, such as reports on developments in trade in services.

From time to time, articles on air transport regulatory topics are presented in the *ICAO Journal*, a monthly magazine which gives a concise account of ICAO activities and features additional information of interest to Contracting States and to the international aeronautical world.

Each item of ICAO policy, guidance and information material is usually disseminated in one of three types of ICAO publications: document, circular or digest.

An *ICAO document* is the publication type used for material considered to have a permanent character or special importance to all Contracting States, such as:

- resolutions, decisions and recommendations formally adopted by the Assembly or the Council, texts approved by the Council, and the minutes of the and of the Council;
- Council Statements on policy relating to air transport questions;
- reports of meetings such as worldwide conferences and divisional sessions convened by the Council or by the Air Transport Committee; and
- guidance and information on international air transport.

An **ICAO circular** is the publication type used to disseminate specialized information of interest to Contracting States.

An **ICAO digest of statistics** is the publication type used when considerable quantitative information is involved.

In addition, an **ICAO State Letter** (which is not published as a saleable ICAO document) is used to convey information on specific topics in a timely manner and often contains a request for a response or action by States.

Apart from the dissemination of printed materials and distinct from the policy development bodies identified earlier, **ICAO regional workshops** are used to inform persons in national administrations or related autonomous agencies about relevant ICAO policies, advice and

information and to provide an opportunity to informally exchange information and views.

ICAO Regional Workshops on Air Transport Regulatory Policy focus on current air transport regulatory issues, including international air transport regulation at the national, bilateral and multilateral levels, both as regards regulatory process and structure and particular areas of regulatory content (e.g. market access, airline ownership and control, codesharing, and airline product distribution) and issues of economic regulation and liberalization.

An **ICAO Regulatory Policy Seminar** has a purpose similar to regional regulatory policy workshops but is shorter in duration and more focussed on the issues and needs of a smaller group of States, typically in a subregion where the seminar is held.

Chapter 3.5

WORLDWIDE INTER- GOVERNMENTAL ORGANIZATIONS

Various worldwide intergovernmental organizations, although not primarily responsible for civil aviation matters, may influence the regulation of international air transport, directly or indirectly, in the course of discharging their broader responsibilities. Most maintain relations with civil aviation bodies, in particular ICAO, on matters of mutual concern. The following sections of this chapter identify three types of such organizations: the organs of the United Nations, the specialized agencies within its system, and other worldwide intergovernmental organizations.

ORGANS OF THE UNITED NATIONS

The *United Nations (UN)*, headquartered in New York City in the United States, was established in 1945 under the *Charter of the United Nations* with the primary objectives of maintaining international peace and security, developing friendly relations among nations, and achieving international cooperation (www.un.org).

The *UN General Assembly* is the sovereign body of the organization, composed of its member States, which convenes every year to discuss and decide matters within the scope of the Charter. On occasion its resolutions on broader matters have affected the regulation of international air services to and from various States.

The *UN Security Council*, consisting of five permanent members (China, France, Russian Federation, United Kingdom, United States) and ten non-permanent members, has primary responsibility for maintaining international peace and security. When it deals with issues of armed conflict or sanctions, its decisions are likely to directly

affect international air transport to and from the relevant national territory or territories.

The *UN Economic and Social Council (ECOSOC)*, composed of 54 UN member States, coordinates the economic and social work of the United Nations. *UN regional commissions* established by the ECOSOC are headquartered in Addis Ababa, Beirut, Bangkok, Geneva and Santiago. In Africa and Asia these commissions sponsor *United Nations Transport and Communications Decades*, each one a ten-year programme designed to mobilize States, intergovernmental organizations, the UN system and external support agencies for cooperative action in the development of transport and communications in the respective regions, with air transport being one of the seven sectors involved.

The *International Court of Justice (ICJ)*, composed of 15 judges and located in The Hague, Netherlands, is the principal judicial organ of the UN and functions in accordance with the Statute of the ICJ. It has jurisdiction over all legal disputes referred to it by States regarding the Charter of the United Nations and treaties in force. It has adjudicated matters involving international air transport regulation, such as the imposition of sanctions in cases of unlawful interference with civil aircraft.

The *UN Secretariat*, headed by a Secretary-General, services the other UN organs, administers the programmes of the organization, and implements its policies. Among other tasks it maintains the *United Nations Treaty Series (UNTS)*, a formal collection of registered treaties and agreements, including air services agreements, on file with the UN. The Secretariat also coordinates with ICAO and other UN specialized agencies on matters of mutual concern.

**SPECIALIZED AGENCIES
OF THE UNITED NATIONS**

Apart from the International Civil Aviation Organization, the specialized agency of the United Nations responsible for civil aviation, six other such agencies have certain limited international air transport-related activities.

The **International Labour Organization (ILO)**, headquartered in Geneva, Switzerland, was established in 1919 with the primary objective of raising working standards throughout the world and seeking to eliminate social injustice. The ILO is concerned, *inter alia*, with the social and labour consequences of economic, regulatory and technological changes in civil aviation (www.ilo.org).

The **International Organization for Standardization (ISO)**, headquartered in Geneva, Switzerland, was established in 1947 to promote the development of standardization and related activities in the world with a view to facilitating the international exchange of goods and services and to developing cooperation. In the international air transport area, the ISO is involved, *inter alia*, in uniform specifications for machine-readable travel documents (passports and visas) as developed by ICAO (www.iso.ch).

The **International Telecommunication Union (ITU)**, headquartered in Geneva, Switzerland, was established in 1865 with the primary objective of maintaining and extending international cooperation between all member States for the improvement and rational use of all types of telecommunications. The ITU's air transport-related tasks centre on its management of the radio frequency spectrum, particularly those parts allocated to aeronautical services (www.itu.int).

The **United Nations Conference on Trade and Development (UNCTAD)**, headquartered in Geneva, Switzerland, was established in 1964 to promote international trade and more particularly, trade between and with developing countries. It serves, *inter alia*, as a forum for the discussion of air transport issues, particularly those facing the least developed, land-locked and island developing countries (www.unctad.org).

The **Universal Postal Union (UPU)**, headquartered in Berne, Switzerland, was established in 1874 to promote the development of communication between peoples by the efficient operation of postal services. The UPU is involved in airmail matters such as conveyance rates, the carriage of

dangerous goods by mail and adaptation of postal services to the increasing competition from private couriers and express/small package operators (www.upu.int).

The **International Bank for Reconstruction and Development (IBRD)**, headquartered in Washington, D.C., USA, part of the **World Bank Group**, has a mission of strengthening economies and expanding markets to improve the quality of life for people everywhere, especially the poorest, by lending money to developing countries for projects, *inter alia*, that build or upgrade airports and other civil aviation related facilities. It was conceived during World War II in meetings at Bretton Woods, New Hampshire, USA, and initially helped rebuild Europe after that war. It does not make grants (www.worldbank.org).

**OTHER WORLDWIDE
INTERGOVERNMENTAL
ORGANIZATIONS**

The **World Trade Organization (WTO-OMC)**, headquartered in Geneva, Switzerland, came into being on 1 January 1995 as the global forum for multilateral trade negotiations and the facilitator of the implementation, administration and operation of multilateral trade agreements. It replaced the entity, also headquartered in Geneva, Switzerland, informally known as the **General Agreement on Tariffs and Trade (GATT)**, one dedicated to the promotion of freer trade worldwide (taking this name from the multilateral trade treaty of the same name which entered into force in January 1948 and remains in effect), and less known by its formal name of **Interim Commission of the International Trade Organization**. Although provisional and intended to last only until its replacement by a proposed specialized agency of the United Nations to be called the **International Trade Organization (ITO)**, it continued to function as the world's only global trade organization until the WTO-OMC came into being. The WTO-OMC was established by an agreement within the Final Act of the **Uruguay Round** of GATT trade negotiations which began at Punta del Este, Uruguay, in 1986, ended at Marrakesh, Morocco, on 15 April 1994, and was the first series of trade negotiations to consider trade in services (including air transport) in addition to trade in goods (www.wto.org).

The **World Tourism Organization (WTO-OMT)**, headquartered in Madrid, Spain, was established in 1975 and entrusted by the United Nations to promote and develop

tourism. Leading this field, it serves as a global forum for tourism policy issues and a practical source of guidance. WTO-OMT's membership includes States and territories and, by affiliation, representatives of local governments, tourism associations and private sector companies, including airlines, hotel groups and tour operators (www.world-tourism.org).

The ***Organisation for Economic Cooperation and Development (OECD)***, headquartered in Paris, France, was established in 1961 to offer its member States a unique forum to discuss, develop and refine economic and social policies. It provides input to policy debates on current and

emerging issues. In air transport (air cargo), the key issues revolve around regulatory reform and trade liberalization (www.oecd.org).

The ***United Nations Framework Convention on Climate Change Secretariat (UNFCCC Secretariat)***, headquartered in Bonn, Germany, was established in 1995 as the permanent Secretariat to the UNFCCC to offer its member States practical arrangements for sessions of Convention bodies. It is institutionally linked to the United Nations and administered under the UN rules and regulations; however, the UNFCCC is not a specialized agency of the United Nations (www.unfccc.int).

Chapter 3.6

REGIONAL INTERGOVERNMENTAL CIVIL AVIATION ORGANIZATIONS

Three regional intergovernmental civil aviation organizations (in Africa, Europe and Latin America and the Caribbean) are headquartered in three ICAO Regional Offices (Dakar, Paris and Lima respectively). These organizations, which bring together national civil aviation officials, seek common regional policies and approaches on air transport regulatory matters. (Appendix 4 of Doc 9587 summarizes policies adopted by these regional organizations.) The three regional organizations, as well as certain subregional ones and that of the Arab States, are identified in the following three sections of this chapter.

AFRICA

The *African Civil Aviation Commission (AFCAC)*, a specialized agency of the Organization of African Unity (OAU) now known as (AU), was established in Addis Ababa, Ethiopia, in January 1969. Membership is open to all African States which are members of the OAU, and to other member States of the United Nations Economic Commission for Africa (ECA), subject to the approval of the OAU. Forty-three States are members of AFCAC (as at this writing) (www.afcac-cafac.org).

AFCAC provides members with a framework for coordination to achieve better utilization and development of the African air transport system and to encourage the application of ICAO standards and recommendations.

The *AFCAC Plenary* is the sovereign body of the organization which convenes every three years to establish the work programme and budget, and to conduct other business. The *AFCAC Bureau*, composed of a President and five Vice-Presidents (representing Northern, Eastern, Central, Western and Southern Africa) who are elected by the Plenary, directs and coordinates the work programme between Plenary sessions.

AFCAC's general air transport policy emphasizes the integration of African airlines via mergers, joint operations, the formation of consortia, the liberal exchange of traffic rights among member States and a common external policy.

AFCAC is a sponsor of the *African Air Tariff Conference*, which was designed to negotiate, coordinate and act upon all air tariff matters of concern to its members. Since 1982, pending ratification of the convention establishing the Conference, the African Airlines Association (AFRAA) has used the Tariff Conference machinery, envisioned in the convention, on an experimental basis for annual meetings in which airline officials discuss and coordinate positions on a variety of tariff issues, generally in advance of IATA tariff coordination meetings.

EUROPE

The *European Civil Aviation Conference (ECAC)* was established in Strasbourg in 1954 pursuant to an initiative by ICAO and the Council of Europe. The primary objective of ECAC is the development of European civil aviation through coordination and cooperation. Forty-one States are members of ECAC (as of August 2003) (www.ecac-ceac.org).

The *ECAC Plenary Conference* is the sovereign body of the organization which meets in Triennial and Intermediate Sessions to consider the work programme and to take basic policy decisions. *ECAC Meetings of Directors General of Civil Aviation (DGCA)* are held frequently for consultations, sometimes on a relatively informal basis, to deal with urgent matters. ECAC also uses numerous working groups, task forces and groups of experts. The *ECAC Coordinating Committee* harmonizes the work of the four Standing Committees and the Meetings of the DGCA, and also supervises the finances of ECAC.

The Conference issues **ECAC resolutions** and **ECAC policy statements** which may be incorporated into the national regulations of each member State. For example, the Conference adopted a Code of Conduct on Computer Reservation Systems in March 1989 with the objective of its unified application among member States. It also acts as a forum for joint discussions between Europe and other regions or States and concludes international agreements, arrangements and memoranda of understanding.

Associated with ECAC is the **Joint Aviation Authorities (JAA)**, a body established in 1979 responsible regionally for air safety including airworthiness, operations and maintenance.

In December 1991, 12 **Commonwealth Independent States (CIS)** (i.e. Armenia, Azerbaijan, Belarus, Georgia, Kazakhstan, Kyrgyzstan, Republic of Moldova, Russian Federation, Tajikistan, Turkmenistan, Ukraine and Uzbekistan) signed at Minsk, Belarus, the **Intergovernmental Agreement on Civil Aviation and Airspace Use**, which established the **Council on Aviation and Airspace Use (CAAU)** and the **Interstate Aviation Committee (IAC)**, a subordinate body responsible for the implementation of the Agreement and coordination of a wide spectrum of civil aviation activities including safety regulation and air transport policy development.

LATIN AMERICA AND THE CARIBBEAN

The **Latin American Civil Aviation Commission (LACAC)** was established at the **Second Conference of Aeronautical Authorities of Latin America**, held in Mexico City in 1973. Membership is open to all American States. Twenty-one States and associates are members of LACAC (as at August 2003).

The primary objective of LACAC is to provide the civil aviation authorities of member States with an appropriate framework within which to discuss and plan cooperative measures and to coordinate their civil aviation activities.

The **LACAC Assembly**, the sovereign body of the Commission, is convened every two years to establish the work

programmes for the Commission and subordinate bodies such as committees, working groups and groups of experts.

The **LACAC Executive Committee**, composed of a President and four Vice-Presidents elected by the LACAC Assembly, administers and coordinates the work programme established by the Assembly. It is assisted by a number of working groups including, in the field of air transport regulation, the **LACAC Group of Experts on Air Transport Policies (GEPTA)** and the **LACAC Group of Experts on Costs and Tariffs (GECOT)**.

The **Andean Committee of Aeronautical Authorities (CAAA)**, composed of national civil aviation authorities of the subregion, was created by a Resolution of the Fifth Meeting of Ministers of Transport, Communications and Public Works of member States of the Andean Pact (Bolivia, Colombia, Ecuador, Peru and Venezuela). It is responsible, *inter alia*, for ensuring compliance with the "Open Skies Policy" adopted by the Commission of the Cartagena Agreement in May 1991, and its overall application.

The **Central American Air Transport Commission (COCATRAE)** was established in September 1991 under the auspices of the Permanent Secretariat of the General Treaty on Central American Economic Integration (SIECA) as a subregional forum on air transport matters.

MIDDLE EAST

The **Arab Civil Aviation Commission (ACAC)** was established in 1995 under the auspices of the League of Arab States and succeeded the **Arab Civil Aviation Council**. Sixteen States are members of ACAC (as at August 2003). Headquartered in Rabat, Morocco, its membership is open to all States that are members of the **League of Arab States**. Objectives of ACAC are: to establish a plan to develop Arab civil aviation and ensure its safety; to promote cooperation and coordination among member States in the field of civil aviation and set the necessary rules and regulations to achieve its uniformity; and to ensure the growth and development of civil aviation to meet the needs of Arab nations for safe, efficient and regular air transport.

Chapter 3.7

REGIONAL AND TRANS-REGIONAL INTERGOVERNMENTAL ORGANIZATIONS AND TRADE AREAS

In addition to worldwide intergovernmental organizations, there exist numerous regional and trans-regional multilateral intergovernmental organizations and trade areas. Certain of these organizations, from time to time, or in a few cases on a continuous basis, participate in the regulation of international air transport. They typically do so by seeking consensus among member States on uniform approaches to policy matters affecting air services of concern to them, and/or through the use of regulations or directives. Others may undertake or sponsor studies, the conclusions of which could affect international air transport regulation. Still others are not active in air transport matters, but could become active or may establish policies which affect such matters.

The first section of this chapter identifies, by world region, regional intergovernmental organizations and arrangements. More extensive information has been provided about the European Union because of its size, complexity and significant involvement with air transport regulation.

A second section identifies various formal trans-regional groups of States. A third section identifies a number of informal trans-regional intergovernmental groups.

REGIONAL INTERGOVERNMENTAL ORGANIZATIONS

AFRICA

Arab Maghreb Union (AMU)

Founded: 1988.

Members: Algeria, Libyan Arab Jamahiriya, Mauritania, Morocco, Tunisia.

Central African Economic Union (CAEU)

Founded: 1964 as the *Central African Customs and Economic Union (CACEU)*.

Headquarters: Yaoundé, Cameroon.

Members: Cameroon, Central African Republic, Chad, Congo, Equatorial Guinea, Gabon.

Council of the Entente (CE)

Founded: 1959.

Headquarters: Abidjan, Côte d'Ivoire.

Members: Benin, Burkina Faso, Côte d'Ivoire, Niger, Togo.

Economic Commission for Africa (ECA)

United Nations regional body.

Founded: 1958.

Headquarters: Addis Ababa, Ethiopia.

Members: 53 States of the region.

Website: www.uneca.org/

E-mail: ecainfo@uneca.org

Economic Community of Central African States (ECCAS)

Founded: 1981.

Headquarters: Libreville, Gabon.

Members: Burundi, Cameroon, Central African Republic, Chad, Congo, Equatorial Guinea, Gabon, Rwanda, Sao Tome and Principe, Democratic Republic of the Congo.

Economic Community of the Great Lakes Countries (CEPGL)

Founded: 1976.

Headquarters: Kigali, Rwanda.

Members: Burundi, Rwanda, Democratic Republic of the Congo.

Economic Community of West African States (ECOWAS)

Founded: 1975.
Headquarters: Abuja, Nigeria.
Members: 16 States of the subregion.
Website: www.ecowas.int/
E-mail: info@ecowasmail.net

Indian Ocean Commission (IOC)

Founded: 1982.
Headquarters: Quatre-Bornes, Mauritius.
Members: Comoros, France (Réunion), Madagascar, Mauritius, Seychelles.
Website: www.coi-info.org
E-mail: coi7@intnet.mu

Organization of African Unity (OAU)

Founded: 1963.
Headquarters: Addis Ababa, Ethiopia. Co-founder of the African Civil Aviation Commission (AFCAC).
Members: 54 African States.
Website: www.oau-oua.org

Common Market for Eastern and Southern Africa

Founded: 1994.
Replaced: the *Preferential Trade Area for Eastern and Southern African States (PTA)*, founded in 1981.
Headquarters: Lusaka, Zambia.
Members: 20 member States of the subregion.
Website: www.comesa.int
E-mail: comesa@comesa.int

Southern African Development Community (SADC)

Founded: 1992.
Replaced: the *Southern African Development Coordination Conference (SADCC)*, founded in 1980.
Headquarters: Gaborone, Botswana.
Members: Angola, Botswana, Democratic Republic of the Congo, Lesotho, Malawi, Mauritius, Mozambique, Namibia, South Africa, Seychelles, Swaziland, United Republic of Tanzania, Zambia, Zimbabwe.
Website: www.sadc.int
E-mail: registry@sadc.int

Southern Africa Transport and Communications Commission (SATCC)

Founded: 1980 as a Sectoral Commission of the SADCC with the same membership as SADCC.
Headquarters: Maputo, Mozambique.
Website: www.satcc.org
E-mail: director@satcc.org

West African Economic Community (CEAO)

Founded: 1994.
Replaced: the *West African Economic Community (CEAO)*, founded in 1959.
Headquarters: Ouagadougou, Burkina Faso.
Members: Benin, Burkina Faso, Côte d'Ivoire, Guinea Bissau, Mali, Niger, Senegal, Togo.

ASIA AND THE PACIFIC

Asean Free Trade Area (AFTA)

Regional trade accord among ASEAN member States. A larger regional group, to be known as the *East Asian Economic Caucus (EAEC)*, has been under consideration to include all the ASEAN members, China, Japan and some other Asian countries.
Website: www.aseansec.org
E-mail: afta@asean.org

Asia-Pacific Economic Cooperation (APEC)

Founded: 1989.
Members: Australia, Brunei Darussalam, Canada, Chile, China, Indonesia, Japan, Malaysia, Mexico, New Zealand, Papua New Guinea, Peru, Philippines, Republic of Korea, Russian Federation, Singapore, Thailand, United States, Viet Nam, and two non-State members, Chinese Taipei and Hong Kong.
Website: www.apecsec.org.sg
E-mail: info@mail.apecsec.org.sg

Association of South East Asian Nations (ASEAN)

Founded: 1967.
Headquarters: Jakarta, Indonesia.
Members: Brunei Darussalam, Cambodia, Indonesia, Lao People's Democratic Republic, Malaysia, Myanmar, Philippines, Singapore, Thailand, Viet Nam.
Website: www.aseansec.org
E-mail: termsak@aseansec.org

Economic and Social Commission for Asia and the Pacific (ESCAP)

United Nations regional body.
Founded: 1947.
Headquarters: Bangkok, Thailand.
Members: Governments of 38 countries of the region, but not including those of certain Western Asian countries which belong to ESCWA (see *FORMAL TRANS-REGIONAL GROUPS*).
Website: www.unescap.org
E-mail: webmaster@unescap.org

Pacific Community

Founded: 1947.
 Former name: *South Pacific Commission (SPC)*.
 Headquarters: Noumea, New Caledonia.
 Members: 27 States/territories of the subregion.
 Website: www.spc.org.nc
 E-mail: spc@spc.int

South Asian Association for Regional Cooperation (SAARC)

Founded: 1985.
 Headquarters: Kathmandu, Nepal.
 Members: Bangladesh, Bhutan, India, Maldives, Nepal, Pakistan, Sri Lanka.
 Website: www.saarc-sec.org
 E-mail: saarc@saarc-sec.org

South Pacific Forum

Founded: 1972.
 Former name: *South Pacific Bureau for Economic Cooperation (SPEC)*.
 Headquarters: Suva, Fiji.
 Members: 16 States/territories of the subregion.
 Website: www.forumsec.org.fj
 E-mail: info@forumsec.org.fj

EUROPE**Central European Initiative (CEI)**

An intergovernmental forum, founded in 1989, for dialogue and cooperation among 17 Central and Eastern Europe countries and the European Bank for Reconstruction and Development (EBRD).
 Website: www.ceinet.org
 E-mail: cei-es@cei-es.org

Council of Europe (CE)

Founded: 1949.
 Headquarters: Strasbourg, France. Was instrumental in the establishment of the European Civil Aviation Conference (ECAC). The *Parliamentary Assembly of the Council of Europe* is the principal legislative body of the CE.
 Website: www.coe.int
 E-mail: webmaster@coe.int

Economic Commission for Europe (ECE)

United Nations regional body.
 Founded: 1947.

Headquarters: Geneva, Switzerland.
 Members: 55 States of the region.
 Website: www.unece.org
 E-mail: infor.ece@unece.org

European Economic Area (EEA)

The EEA Agreement unites the 15 EU member States and the three EFTA EEA States (Iceland, Liechtenstein and Norway) into one single market governed by the same basic rules which facilitate free movement of goods, capital, services and persons and competition rules.

European Union (EU)

A unique, treaty-based, institutional framework that defines and manages economic and political cooperation among its 15 European member States (expected to expand to 25 by 2004).

The EU's origins go back to 9 May 1950, when French Foreign Minister Robert Schuman proposed pooling European coal and steel production under a common authority. Building upon this idea, on 18 April 1951, the *European Coal and Steel Community (ECSC)* was established by six European States (Belgium, France, the Federal Republic of Germany, Italy, Luxembourg and the Netherlands) and given portions of their sovereign powers. Its success led to the creation by the six, by means of the *Rome Treaties* signed on 25 March 1957, of the *European Atomic Energy Community (EAEC or EURATOM)* to further the development of nuclear energy for peaceful purposes and the *European Economic Community (EEC)* to merge national markets into a single market. Collectively, the three became known in 1967 as the *European Communities*, the institutions of which were merged into the dominant EEC by treaty signed on 8 April 1965. The United Kingdom, Ireland, and Denmark joined in 1973; Greece in 1981; Spain and Portugal in 1986; and Austria, Finland and Sweden in 1995. Ten additional eastern European States are expected to join in 2004.

The *Treaty on European Union*, also known as the *Maastricht Treaty*, which entered into effect on 1 November 1993, significantly changed the founding treaties and created the European Union (EU). The three founding treaties of the European Communities now formed the *European Community (EC)*, one of three parts of the EU, the other parts being the *Common Foreign and Security Policy (CFSP)* and *Justice and Home Affairs (JHA)*, the latter two operating by intergovernmental cooperation rather than by

the *Community institutions*. The Maastricht Treaty also cleared the completion of the **Economic and Monetary Union (EMU)**, which launched the Euro currency on 1 January 1999. The treaty additionally created a **European Central Bank**.

The EC operates with five principal institutions, each with a specific role:

The **European Commission**, consisting of 20 Commissioners, proposes policies and legislation, ensures that provisions of treaties and Community decisions are implemented and is supported by an administrative staff divided into 23 administrative departments called **Directorates-General (DG)**. Those which are most involved in air transport matters are **DG VII (Transport)**, **DG IV (Competition)**, and **DG XI (Environment, Consumer Protection and Nuclear Safety)**. Draft legislation is usually developed within one or more of these directorates-general, and then submitted for approval to the Commission. The Commission represents the EC at ICAO meetings.

Once approved by the Commission, legislative proposals are submitted to the **Council of the European Union**, a decision-making body composed of ministers of member States (changing according to the subject discussed) which, inter alia, exercises legislative power, coordinates economic policies, and concludes international agreements. Proposals which have been adopted by the Council usually take the form of **Council Regulations**, which apply directly to member States and/or other entities, or **Council Directives**, which lay down compulsory objectives for member States to achieve by regulation. Where it has been given the necessary powers on certain subjects the Commission may itself issue **Commission Regulations** for direct application to member States and/or other entities, without following the above process.

The third principal institution, the **European Parliament (EP)**, its 626 members directly elected by the citizens of the EU, acts as a public forum on issues of importance, has limited legislative and budgetary roles shared with the Council, and exercises democratic supervision over the Commission.

The other two such institutions are the **European Court of Justice (ECJ)**, comprised of 15 judges assisted by 9 advocates-general, which interprets EU law, and the **European Court of Auditors (ECA)**, with 15 appointed members, which monitors the EU's finances.

Two advisory bodies to the Council also exist: the **Economic and Social Committee (ECS)**, which has 222 members who represent employees, farmers, consumers and other such groups and express views on economic and social issues; and the **Committee of the Regions (COR)**, which also has 222 members, in this case representing local and regional authorities who express views on regional policy, the environment and education.

Website: www.europa.eu.int

European Free Trade Association (EFTA)

Founded: 1960 under **Stockholm Convention**.

Headquarters: Geneva, Switzerland.

Members: Austria, Finland, Iceland, Liechtenstein, Norway, Sweden, Switzerland.

Website: www.efta.int

E-mail: efta-mailbox@efta.int

Nordic Council (NC)

Founded: 1952.

Headquarters: Stockholm, Sweden.

Members: Denmark, Finland, Iceland, Norway, Sweden and three autonomous territories (the Aaland Islands, the Faeroe Islands, Greenland).

Website: www.norden.org

E-mail: nordisk-rad@nordisk-rad.dk

Single European Market

A unified economic area with the free movement of goods, persons, services and capital among member States of the EU. The EU's single market for air transport is based on a phased programme of three "liberalization packages", the last of which took effect on 1 January 1993. A transitional period was laid down for access to intra-community air routes, which became reality on 1 April 1997. Community policy on liberalizing air transport covers four main areas: market access, capacity control, fares and the issue of operating licenses for companies.

LATIN AMERICA AND THE CARIBBEAN

Andean Community

Founded: 1969 under **Cartagena Agreement**.

Headquarters: Lima, Peru.

Members: Bolivia, Colombia, Ecuador, Peru, Venezuela. (See Decision 297 of the Commission on the Cartagena

Accord, which established an “open skies” air transport policy for the Andean Pact member States, in Chapter 3.2 of the manual.)

Website: www.comunidadandina.org

E-mail: contacto@comunidadandina.org

Caribbean Community and Common Market (CARICOM)

Founded: 1973 under *Treaty of Chaguaramas*.

Headquarters: Georgetown, Guyana.

Members: Antigua and Barbuda, Bahamas, Barbados, Belize, Dominica, Grenada, Guyana, Jamaica, Montserrat, Saint Kitts and Nevis, Saint Lucia, Saint Vincent and the Grenadines, Suriname, Trinidad and Tobago.

Associate members: British Virgin Islands, Haiti, Turks and Caicos Islands.

Website: www.caricom.org

E-mail: indrad@caricom.org

Central American Common Market (CACM)

Founded: 1960.

Headquarters: Guatemala City, Guatemala.

Members: Costa Rica, El Salvador, Guatemala, Honduras, Nicaragua. The same group signed a framework free trade agreement with Mexico in 1992.

Economic Commission for Latin America and the Caribbean (ECLAC)

United Nations regional body.

Founded: 1948.

Headquarters: Santiago, Chile.

Members: 41 States of the region.

Website: www.eclac.org

E-mail: info@eclac.org

Latin American Economic System (SELA)

Founded: 1975.

Headquarters: Caracas, Venezuela.

Members: 28 States of Latin America.

Website: www.sela.org

E-mail: difusion@sela.org

Latin American Integration Association (LAIA)

Founded: 1980 under *Montevideo Treaty*.

Headquarters: Montevideo, Uruguay.

Members: Argentina, Bolivia, Brazil, Chile, Colombia, Cuba, Ecuador, Mexico, Paraguay, Peru, Uruguay, Venezuela.

Website: www.aladi.org

E-mail: sgaladi@aladi.org

Central American Integration System

Founded: 1951 as *Organization of Central American States (OCAS)*.

Headquarters: San Salvador, El Salvador.

Members: Costa Rica, El Salvador, Guatemala, Honduras, Nicaragua.

Organization of Eastern Caribbean States (OECS)

Founded: 1981.

Headquarters: Castries, Saint Lucia.

Members: Anguilla, Antigua and Barbuda, Dominica, Grenada, Montserrat, Saint Kitts and Nevis, Saint Lucia, Saint Vincent and the Grenadines, British Virgin Islands.

Website: www.oecs.org

E-mail: oesec@oecs.org

Permanent Secretariat of the General Treaty on Central American Economic Integration (SIECA)

Founded: 1960.

Headquarters: Guatemala City, Guatemala.

Members: Belize, Costa Rica, El Salvador, Guatemala, Honduras, Nicaragua, Panama.

Website: www.sieca.org.gt

Southern Cone Common Market (MERCOSUR)

Founded: 1990 under *Mercosur Treaty*.

Headquarters: Montevideo, Uruguay.

Members: Argentina, Brazil, Paraguay, Uruguay.

Associate member: Bolivia.

MIDDLE EAST

Cooperation Council for the Arab States of the Gulf (GCC) (Also referred to as *Gulf Cooperation Council*)

Founded: 1981.

Headquarters: Riyadh, Saudi Arabia.

Members: Bahrain, Oman, Kuwait, Qatar, Saudi Arabia, United Arab Emirates.

Website: www.gcc-sg.org

NORTH AMERICA

North American Free Trade Agreement (NAFTA)

Founded: 1994.

Members: Canada, Mexico, United States.

Website: www.nafta-sec-alena.org

E-mail: webmaster@nafta-sec-alena.org

FORMAL TRANS-REGIONAL GROUPS

African, Caribbean and Pacific Group of States (ACP Group)

Founded: 1975 under *Lomé Convention*.
 Headquarters: Brussels, Belgium.
 Members: 78 developing countries which relate through this group to the European Community.
 Website: www.acpsec.org
 E-mail: info@acpsec.org

Arab Common Market (ACM)

Founded: 1964.
 Headquarters: Amman, Jordan.
 Members: Egypt, Iraq, Jordan, Libyan Arab Jamahiriya, Mauritania, Syrian Arab Republic, Yemen.

Economic and Social Commission for Western Asia (ESCWA)

United Nations regional body.
 Founded: 1973.
 Headquarters: Beirut, Lebanon.
 Members: Bahrain, Egypt, Iraq, Jordan, Kuwait, Lebanon, Oman, Palestine, Qatar, Saudi Arabia, Syrian Arab Republic, United Arab Emirates, Yemen.
 Website: www.escwa.org.lb
 E-mail: webmaster-escwa@un.org

Economic Cooperation Organization (ECO)

Founded: 1984 under the *Treaty of Izmir*.
 Headquarters: Tehran, Islamic Republic of Iran.
 Original members: Islamic Republic of Iran, Pakistan, Turkey. Expanded in 1992 to include Afghanistan, Azerbaijan, Kazakhstan, Kyrgyzstan, Tajikistan, Turkmenistan, Uzbekistan.
 Website: www.ecosecretariat.org
 E-mail: registry@ecosecretariat.org

League of Arab States (LAS)

Founded: 1945.
 Headquarters: Cairo, Egypt.

Members: 22 Arab States. The *Council of Arab Ministers of Transport* deals with civil aviation.
 Website: www.leagueofarabstates.org

Organization of American States (OAS)

Founded: 1890 as the *International Union of American Republics*, which became the *Pan American Union* in 1910, then the OAS in 1948.
 Headquarters: Washington, D.C., United States.
 Members: 35 States of North and South America and the Caribbean.
 Website: www.oas.org
 E-mail: svillagran@oas.org

INFORMAL TRANS-REGIONAL GROUPS

Group of Eight (G-8)

Group of major industrialized States. Formerly the *Group of Seven (G-7)* until joined by the Russian Federation.
 Members: Canada, France, Germany, Italy, Japan, Russian Federation, United Kingdom, United States.

Group of Seventy Seven (G-77)

Group of developing States organized to promote their views on international trade and development in UNCTAD.
 Members: 133 States (originally established with 77 States).
 Website: www.g77.org
 E-mail: g77off@unmail.org

Paris Club or Club of Paris

A forum for officials of creditor governments to collaborate on debt collection and debt forgiveness policies. The composition of the group is likely to vary according to the particular creditor States involved and the debtor States in question. Based in Paris, the “club” is run by the French Treasury.
 Website: www.clubdeparis.org
 E-mail: webmaster@clubdeparis.org

Chapter 3.8

INTERNATIONAL AIR TRANSPORT ASSOCIATION (IATA)

The **International Air Transport Association (IATA)** is the worldwide non-governmental organization of scheduled airlines established in 1945 to promote safe, regular and economical air transport, to provide means for collaboration among air transport enterprises, and to cooperate with ICAO, other international organizations and regional airline associations (website: www.iata.org). IATA has two main offices (one in Montreal and the other in Geneva) and over 90 regional offices.

IATA membership is open to any operating company which has been licensed to provide international air service. IATA active membership is open to airlines engaged directly in international operations, while IATA associate membership is open to domestic airlines. IATA has over 270 member airlines.

The first section of this chapter identifies the main components of the IATA organizational structure.

The second section explains the IATA Traffic Conference structure.

The third section provides a brief general description of the process of multilateral tariff coordination within the IATA Traffic Conferences. The final section identifies various trade association activities (other than Procedures Conferences, which are explained in the second section).

MAIN COMPONENTS OF THE IATA ORGANIZATIONAL STRUCTURE

The **IATA Annual General Meeting (AGM)** is the sovereign body of the association. All active members have an equal vote in its decisions. It is convened every year as the “World Air Transport Summit” in recognition of its status

as the premier, industry-wide platform for the debate of critical issues at the highest level.

The **IATA Board of Governors (BG)**, composed of elected Chief Executives of member airlines, provides year-round policy direction.

IATA Special Committees are established from time to time, with the approval of the Board of Governors, to advise on subjects of special concern to the industry. Other bodies such as subcommittees, boards, panels and working groups are also established from time to time with specific terms of reference.

The four **IATA Standing Committees** (Financial, Industry Affairs, Operations and Cargo) are composed of experts nominated by individual member airlines. The **IATA Industry Affairs Committee (IAC)** advises the Board of Governors and the Director General on all commercial matters connected with international air transport and oversees the work of the Traffic Conferences (as explained in the next two sections).

The **IATA Secretariat**, a staff headed by the Director General and Chief Executive Officer, supports general and committee meetings and the various Traffic Conferences and also performs several functions for, and provides various services to, member airlines and others. Some of these functions and services are identified in the final section of this chapter.

THE IATA TRAFFIC CONFERENCE STRUCTURE

The **IATA Traffic Conference** structure consists of Procedures Conferences and Tariff Coordinating Conferences

and is governed by the Provisions for the Conduct of Traffic Conferences, which provide government-approved terms of reference for conferences.

The **IATA Procedures Conference** structure coordinates commercial practices (a trade association activity) and includes the:

- **IATA Passenger Services Conference (PSC)** which takes action on passenger services including passenger and baggage handling, documentation, procedures, rules and regulations, reservations, ticketing, schedules and automation standards;
- **IATA Passenger Agency Conference (PAConf)** which takes action on relationships between airlines and accredited passenger sales agents and other intermediaries but excluding remuneration levels;
- **IATA Cargo Services Conference (CSC)** which takes action on facilitating and improving the processing of air cargo through standardization of procedures, data exchanges and systems; and the
- **IATA Cargo Agency Conference (CAConf)** which takes action on relationships between airlines and intermediaries engaged in the sale and/or processing of international air cargo but excluding remuneration levels.

The **IATA Tariff Coordinating Conference (TC)** structure conducts tariff negotiations (an optional-participation activity) and includes the:

- **IATA Passenger Tariff Coordinating Conferences (PTCs)** which develop passenger fares and related conditions; and
- **IATA Cargo Tariff Coordinating Conferences (CTCs)** which develop cargo rates and related conditions.

Both the PTCs and the CTCs consist of a number of **Area Conferences** based on three geographical conference areas:

- **Area 1**, which encompasses all of the North and South American continents and the islands adjacent thereto, Greenland, Bermuda, the West Indies and

islands of the Caribbean Sea, the Hawaiian Islands (including Midway and Palmyra);

- **Area 2**, which encompasses all of Europe (including that part of the Russian Federation in Europe) and the islands adjacent thereto, Iceland, the Azores, all of Africa and the islands adjacent thereto, Ascension Island, and that part of Asia lying west of and including the Islamic Republic of Iran; and
- **Area 3**, which encompasses all of Asia and the islands adjacent thereto except the portion included in Area 2, all of the East Indies, Australia, New Zealand and the islands adjacent thereto, and the islands of the Pacific Ocean other than those included in Area 1.

Area Conferences TC1, TC2 and TC3 determine tariffs within the respective areas 1, 2 and 3. Area Conferences TC12, TC23, TC31 and TC123 determine tariffs between Areas 1 and 2, 2 and 3, 3 and 1, and those involving all three Areas, respectively. Each Area Conference is further divided by so-called **Sub-Area Conferences** based on sub-areas within and between the above three areas.

In addition to the Area/Sub-Area Conferences, there are **Composite Meetings** of the PTC and the CTC, which deal with global features of tariff levels and conditions such as fare/rate construction and currency rules, conditions of service, baggage allowances and charges, and remuneration levels.

TARIFF COORDINATION PROCESS

The **IATA tariff coordination process** is one of negotiations among participating airlines of passenger fare and cargo rate levels and conditions to develop and adopt agreements (in the form of resolutions) for submission to governments for approval.

A **TC member**, i.e. an airline that has chosen to participate in passenger and/or cargo tariff coordination, automatically becomes a voting member of each Area Conference (and Sub-Area Conference) in which it operates services under Third and Fourth Freedom traffic rights. A TC member may also elect to become a voting member of any Area/Sub-Area Conference in which it operates a service under Fifth Freedom traffic rights. Additionally, a TC

member may elect to become a voting member of TC12, TC23, TC31 and TC123 if it does not operate in such an area, but does operate as a voting member in a component area; for example, a voting member operating only in TC2 may elect to become a voting member in TC12, TC23, TC123 but not TC31.

Each Tariff Coordinating Conference meeting must be called at least once every two years on 90 days' notice. In practice, however, most meetings of Passenger Area/Sub-Area Conferences are held once a year in areas where the markets are reasonably stable. Areas with rapidly changing fares may need to meet up to three times a year. Composite Meetings are usually held once a year. Special meetings can be called at short notice (as little as 15 days in advance) to discuss urgent tariff-related issues as required, globally or on an area basis.

In principle, each Conference meeting aims to reach a consensus on both the general levels of tariffs and specific tariff proposals on a full conference basis. Whenever it does, the agreements reached apply to all TC members, whether or not represented at the meeting.

All agreements of a Conference must be adopted by a unanimous vote. However, if a full conference agreement cannot be achieved, "sub-area" agreements and/or "limited" agreements (limited in respect of the TC members participating in the agreements and/or the countries covered by the agreements), may be reached to meet particular needs of TC members operating services in the region concerned.

Towards the end of a meeting, a **Package** which consists of changes to rules/conditions that are shown in the form of draft **Resolution Documents (Res. Docs.)** and changes to fare/rate levels/structures that are shown in an attachment of the Resolution, is presented by the chairman to the attending TC members. The Package stipulates the positions of each TC member up to final voting, and reflects all the agreements and any compromises tentatively reached during the Conference meeting. If adopted, the Package is converted into **Resolutions**, which together with the minutes of the meeting, tables of fares and/or rates and memoranda reflecting the agreement, are circulated to TC members and submitted for approval to governments. If not adopted, the conference area or any sub-area concerned becomes an **open area**, i.e. one in which there is no formal IATA agreement.

Resolutions agreed at a Conference are assigned a filing period by the Conference. Each TC member determines

which resolutions must be submitted to its own governmental authorities with a request for action on them within that period. TC members must notify IATA of any action, intended action, or extension of the time being taken for consideration by its authorities. IATA notifies TC members of the government approval status. When all known and necessary government approvals have been received, IATA declares the agreement effective and TC members are able to implement it.

TC members may change existing agreements between Conference meetings by:

- using specified Conference-adopted procedures to introduce "innovative" passenger fares or cargo rates without necessarily affecting a passenger fares or cargo rates agreement in the area concerned; and/or
- making a tariff proposal to be circulated for mail vote consideration by all TC members concerned who have relevant voting rights (which can be declared adopted if no negative vote is cast).

TRADE ASSOCIATION ACTIVITIES

In common with similar organizations, IATA conducts trade association activities in which all member airlines participate. Apart from tariff coordination (which is not a trade association activity) and the previously explained Procedures Conferences, IATA engages in three distinct types of trade association activity:

- certain core functions, including representation on behalf of industry, governmental and consumer relations, technical activities, legal support and industry automation;
- various other industry coordination activities including facilitation and fraud prevention; and
- numerous self-financing services such as publications, financial services, agents accreditation, aviation training, yield management programmes and symposia.

Among the most noteworthy IATA services which are related to air transport regulation are:

- the **IATA Schedules Conference**, held twice yearly, where airlines coordinate their schedules and airport **slots** (specific times allotted for an aircraft to land or take off);
- the **Billing and Settlement Plan (BSP)**, which provides for the computerized processing of accounts between airlines and their passenger agents;
- the **Cargo Accounting Settlement System (CASS)**, which provides for the computerized processing of accounts between airlines and their cargo agents;
- the **Clearing House**, which includes proration services and enables airlines (and suppliers) to settle credits and debits between themselves at one location, thus minimizing the need to make actual transfers of money on a worldwide basis;
- the **IATA/SITA baggage tracing (BAGTRAC) system**, to recover checked baggage that is lost or misdirected; and
- the **Multilateral Interline Traffic Agreement (MITA)**, i.e. a legally binding agreement relating to issuance of passenger tickets and cargo waybills and the acceptance of each other's passengers, baggage and cargos.

The **Electronic Data Interchange for Administration, Commerce and Transport (EDIFACT)** is used by IATA to develop message formats for the exchange of passenger, cargo, fuel invoice and fuel delivery information among airlines and their business partners. Recently, IATA and SITA have joined together to offer connectivity between airlines using EDIFACT messaging to facilitate the use of electronic tickets (e-tickets) in the interline environments.

Chapter 3.9

NON-GOVERNMENTAL ORGANIZATIONS

Apart from intergovernmental organizations, there exist numerous worldwide, regional and trans-regional non-governmental organizations. Some of these organizations, from time to time, or in some cases on a recurring basis, seek to influence the governmental regulation of international air transport directly or indirectly. Many typically do so by aggregating the commonly held views of their members on matters relating to international air transport and articulating such views, publicly and/or through communications with (and participation in various meetings of) governmental and intergovernmental bodies. Others undertake or sponsor studies which can inform or influence those conducting international air transport regulation. Their degree of focus on air transport issues, as distinct from other issues, varies by organization.

This chapter identifies numerous non-governmental organizations which may influence air transport regulation. The list is not necessarily exhaustive.

The first section of this chapter identifies air carrier organizations (except for the International Air Transport Association (IATA) which is treated separately in Chapter 3.8).

The second section identifies other aviation organizations.

The final section identifies other organizations interested in air transport.

AIR CARRIER ORGANIZATIONS

African Airlines Association (AFRAA)

Founded: 1968.

Headquarters: Nairobi, Kenya.

Members: air carriers owned by member States of the OAU or controlled by nationals of OAU States.

Website: www.afraa.org

E-mail: afraa@africanonline.co.ke

Air Charter Carriers Association (ACCA)

Founded: 1971.

Members: non-scheduled operators based in Europe which are affiliates or subsidiaries of IATA airlines.

Air Transport Association of America (ATA)

Founded: 1936.

Headquarters: Washington, D.C., United States.

Members: 22 principal airlines in the United States and 5 associate non-US airlines.

Arab Air Carriers Organization (AACO)

Founded: 1965 under the auspices of the League of Arab States.

Headquarters: Beirut, Lebanon.

Members: airlines of States which are members of the League.

Website: www.aaco.org

E-mail: info@aaco.org

Association of Asia Pacific Airlines (AAPA)

Founded: 1966, as the *Orient Airlines Research Bureau*. In 1970 it became the *Orient Airlines Association (OAA)*.

Headquarters: Kuala Lumpur, Malaysia.

Members: seventeen scheduled international airlines in the region.

Website: www.aapairlines.org

E-mail: aapahdq@aapa.org.my

Asociación Internacional de Transporte

Aéreo Latinoamericano (AITAL)

Founded: 1980.

Headquarters: Bogotá, Colombia.

Members: airlines based in Latin America.

Website: www.aital.org

E-mail: contactenos@aital.org

Association Internationale de Transporteurs Aériens (ATAF)

Founded: 1950.

Headquarters: Paris, France.
 Members: 16 airlines based in Francophone African States, France and overseas territories.
 E-mail: ataf@wanadoo.fr

Association of European Airlines (AEA)

Founded: 1954 as the *European Airlines Research Bureau (EARB)*.
 Headquarters: Brussels, Belgium.
 Members: major European scheduled airlines.
 Website: www.aea.be
 E-mail: aea.secretariat@aea.be

Association of South Pacific Airlines (ASPA)

Founded: 1979.
 Headquarters: Nadi, Fiji.
 Members: 16 regional airlines, 2 associates and 18 industry providers in 15 countries and territories.

European Regions Airlines Association (ERA)

Founded: 1980.
 Headquarters: Chobham, United Kingdom.
 Members: some 70 airlines and 160 associate and affiliate members comprising regional airports, aircraft and engine manufacturers, and avionic suppliers and service providers.
 Website: www.eraa.org
 E-mail: info@eraa.org

International Air Carrier Association (IACA)

Founded: 1971.
 Headquarters: Brussels, Belgium.
 Members: air carriers engaged in non-scheduled air services.
 Website: www.iaca.be
 E-mail: iaca.hq@iaca.be

OTHER AVIATION ORGANIZATIONS

Airports Council International (ACI)

Previously known as the *Airports Association Council International (AACI)*, a union of the former *Airport Operators Council International (AOCI)* and the former *International Civil Airports Association (ICAA)*.
 Founded: 1991.
 Headquarters: Geneva, Switzerland.
 Members: over 400 international airports, airport authorities and national airport associations in over 110 States.

Website: www.airports.org
 E-mail: info@airports.org

International Business Aviation Council (IBAC)

Founded: 1981.
 Headquarters: Montreal, Canada.
 Members: business aviation companies in over 20 States and territories.
 Website: www.ibac.org
 E-mail: info@ibac.org

International Council of Aircraft Owner and Pilot Associations (IAOPA)

Founded: 1964.
 Headquarters: Frederick, Maryland, United States.
 Members: national general aviation organizations representing 400 000 pilots in over 53 States.
 Website: www.iaopa.org
 E-mail: iaopa@aopa.org

International Federation of Air Line Pilots' Associations (IFALPA)

Founded: 1948.
 Headquarters: Surrey, United Kingdom.
 Members: national airline pilots associations in over 70 States and territories.
 Website: www.ifalpa.org
 E-mail: globalpilot@ifalpa.org

**OTHER ORGANIZATIONS
 INTERESTED IN AIR TRANSPORT**

Consumers International, formerly known as the *International Organization of Consumers Unions (IOCU)*

Founded: 1960.
 Headquarters: London, United Kingdom.
 Members: consumer associations, government-financed consumer councils, labour unions and similar groups.
 Website: www.consumersinternational.org
 E-mail: consint@consint.org

Federation of Air Transport User Representatives in Europe (FATURE)

Founded: 1983, as the *Federation of Air Transport User Representatives in the European Community*.
 Headquarters: Paris, France.
 Members: various user organizations in the European community.

Institut du Droit International (IDI)

Founded: 1873.
Headquarters: Geneva, Switzerland.
Members: individuals and national associations in 49 countries concerned with international law including air transport studies.
E-mail: gerardi@hei.unige.ch

Institut du Transport Aérien (ITA)

Founded: 1954.
Headquarters: Paris, France.
Members: individuals and national organizations concerned with air transport studies in over 70 States.
Website: www.ita-paris.com
E-mail: contact@ita-paris.com

International Business Travel Association (IBTA)

Headquarters: Brussels, Belgium.
Members: European national business travel federations of travel services in industrial and commercial enterprises.
Website : www.ibta.com
E-mail: info@ibta.com

International Chamber of Commerce (ICC)

Founded: 1920.
Headquarters: Paris, France.
Members: national committees representing commerce, industry, transportation and finance in over 50 States.
Website: www.iccwbo.org
E-mail: webmaster@iccwbo.org

International Federation of Freight Forwarders Associations (FIATA)

Founded: 1926 as *International Federation of Forwarding Organizations*.
Headquarters: Zurich, Switzerland.
Members: national associations of freight forwarders in some 90 States and territories.
Website: www.fiata.com
E-mail: info@fiata.com

International Federation of Tour Operators (IFTO)

Founded: 1970.
Headquarters: Lewes, United Kingdom.
Members: national associations of tour operators.

International Foundation of Airline Passengers' Association (IFAPA)

Founded: 1985.
Headquarters: Geneva, Switzerland.
Members: airline passengers' associations.

International Law Association (ILA)

Founded: 1873.
Headquarters: London, United Kingdom.
Members: individuals and national associations concerned with international law, including aviation law.
Website: www.ila-hq.org
E-mail: info@ila-hq.org

International Transport Workers' Federation (ITF)

Founded: 1896 as the *International Federation of Ship, Dock and River Workers*.
Headquarters: London, United Kingdom.
Members: national transport workers' unions in over 80 States and territories.
Website: www.itf.org.uk
E-mail: mail@itf.org.uk

Pacific Asia Travel Association (PATA)

Founded: 1951.
Headquarters: Bangkok, Thailand.
Members: governments, airlines, travel agents, hotels.
Website: www.pata.org
E-mail: patabkk@pata.th.com

Société Internationale de Télécommunications Aéronautiques (SITA)

Founded: 1949.
Headquarters: Paris, France.
Members: over 400 airlines and air transport related organizations (including telecommunication and information processing services).
Website: www.sita.int
E-mail: info@sita.int

Universal Federation of Travel Agents' Associations (UFTAA)

Founded: 1966.
Headquarters: Monaco.
Members: national associations representing over 50 000 travel agents in more than 80 States and territories.
Website: www.uftaa.com
E-mail: uftaamc@tekworld.mc

World Travel and Tourism Council (WTTC)

Headquarters: Brussels, Belgium.
Members: about 40 chief executive officers from companies in all sectors of the travel industry including transportation, accommodation, catering, recreation, cultural and travel services.
Website: www.wttc.org
E-mail: enquiries@wttc.org

Part 4

REGULATORY CONTENT

Chapter 4.0

INTRODUCTION TO REGULATORY CONTENT

Regulatory content is defined in the Foreword as “the particular subjects being regulated (such as market access, pricing and capacity)”. Part 4 of the manual deals with subjects which make up the regulatory content in the economic field of international air transport. Air transport regulators face these regulatory content subjects in all three venues of regulation, i.e. national, bilateral and multilateral. Though distinct from one another, these subjects, in practice, are rarely treated in isolation because of their interrelationships.

Chapter 4.1 uses a building block approach to identify and explain the three basic market access rights, i.e. route, operational and traffic rights, which are the most important element of international air transport regulation. The chapter also discusses market access in terms of the so-called “Sixth Freedom”.

The subject of capacity, an important element of air transport regulation, is examined in Chapter 4.2. This chapter describes the involvement of governments in air carrier capacity regulation, and capacity regulation viewed from an air carrier perspective.

Air carrier tariffs, another principal element in economic regulation, are discussed in Chapter 4.3. Tariff-related terms, different types and characteristics of tariffs, and methods for regulating tariffs, as well as some key tariff issues are examined.

Chapter 4.4. discusses air carrier ownership and control, a subject that has evoked considerable interest in recent times because of the changes in the airline industry brought about by globalization, liberalization and privatization (which often involves transnational investment in air carriers). The chapter describes the traditional criteria used by States for airline designation and authorization, the rationale for their use, and some exceptions. It also briefly discusses the implications of foreign investment in air carriers

and, lastly, examines some key issues in liberalizing airline ownership and control.

Chapter 4.5 deals with air cargo, an increasingly important component of international air transport, identifying the distinct features of air cargo and describing how air cargo service is regulated.

The subject of non-scheduled air services is covered in Chapter 4.6. It describes the characteristics which set it apart from scheduled air services, identifies the numerous kinds of international non-scheduled operations and discusses how governments regulate them.

Chapter 4.7 is devoted to airline commercial activities (sometimes referred to as “doing business” matters) which can be important in the provision of international air services in a foreign country. The activities described in this chapter are currency conversion and remittance of earnings, employment of non-national personnel, sale and marketing of international air transport, airline product distribution and electronic commerce, and aircraft leasing. They can, in certain circumstances, be regarded by air carriers and States with the same degree of importance as the three principal regulatory elements of market access, capacity and tariffs.

Chapter 4.8 provides information on three major airline cooperative activities, namely, airline alliances, codesharing and franchising, and discusses their regulatory implications.

Chapter 4.9 is devoted to air passengers. It discusses passenger rights, the relatively new topics of unruly or disruptive passengers, and improperly documented passengers.

Chapter 4.10 covers airport-related matters. It contains information on ground handling, slot allocation at international airports and privatization of airports.

Chapter 4.1

BASIC MARKET ACCESS

An **air transport market** between any two places consists of the actual and potential traffic in persons and goods that does move or may move between such places on commercial air services. International air transport markets can fall into four categories in a hierarchical structure: a **city-pair market**, i.e. the air route linking two cities (e.g. New York-London); a **country-pair market**, consisting of all city-pair routes linking two countries (e.g. United States-United Kingdom); a **region-to-region market**, one that includes all routes linking two regions (e.g. North America-Europe, also known as the North Atlantic market); and the **global market** which includes all points served in the world by the airline industry. A scheduled air service is likely to carry traffic moving in numerous city-pair markets on each flight; a non-scheduled air service typically, but not always, serves a single city-pair market on each flight.

Air transport market access, by any particular air carrier or carriers, is the nature and extent of the basic rights (with any accompanying conditions and limitations) that are granted/authorized by the relevant governmental authorities (and identified and discussed in this chapter) as well as ancillary rights such as those covering product distribution. **Air transport market penetration** by any particular air carrier or carriers is the extent to which access is actually used to obtain and carry traffic. Rights can be subject to numerous constraints (outside the scope of this chapter) such as aircraft range and payload limitations, airport congestion and distribution system problems.

Access by an air carrier to a State's domestic air transport market is typically obtained (with relatively few exceptions) only if it is a carrier of that State and is usually acquired by a licensing process. Access to an international air transport market is also usually acquired by a licensing or approval process in each State involved. The reason for this dates back to the earliest period of flight when States recognized that every State has and may exercise complete and exclusive sovereignty over the airspace above its territory. This principle is reaffirmed in Article 1 of the Chicago Convention, and this exercise of sovereignty is usually

expressed in a licensing or approval process. Thus, primarily because of the need to use the territorial airspace of another State in order to serve an international market, access to such air transport markets by foreign air carriers has come to be regulated in very different ways than access by foreign entities in other service industries (e.g. hotel chains and telecommunications companies).

Commercial air transport services, when performed as other than scheduled international air services involving ICAO Contracting States, are subject to Article 5 of the Chicago Convention. Under that Article, the foreign aircraft of such a State have the right to fly into or in transit non-stop across the territory of any other ICAO Contracting State and to make stops for non-traffic purposes (such as refuelling or repairs) without the necessity of obtaining prior permission, and subject to the right of the State flown over to require landing. That Article also extends the privilege of taking on or discharging traffic (i.e. obtaining access to the non-scheduled market), subject to the right of any State where such embarkation or discharge takes place to impose such regulations, conditions or limitations as it may consider desirable. In actual practice, such impositions may result in denial of or various constraints on market access by non-scheduled services, and in the absence of agreement between the States concerned, it is regulated unilaterally, usually on the basis of comity and reciprocity.

Scheduled international air services are regulated in a basic way by Article 6 of the Chicago Convention. That Article prohibits such services without the special permission or other authorization of the foreign State involved. In practice, a State extends such permission or authorization for scheduled international services by foreign air carriers in licences or permits of fixed or conditioned duration and does so (with rare exceptions) on the basis of the service being the utilization of market access rights which that State has granted to the home State(s) of the air carrier.

A basic market access right is a conditioned or limited right or privilege (usually set out in an international

agreement) granted by one State to another State for use by an air carrier or carriers designated by that other State and may consist of agreed: geographic specifications of routes along which the air service may take place; physical specifications regarding designation of an air carrier or carriers and how a designated carrier may employ aircraft; and physical and/or geographic specifications of what kinds of traffic may be carried. Such rights in total determine the extent of market access granted.

Market access rights are usually granted in exchange for similar rights by means of some agreement(s) or arrangement(s) between States and are usually limited to scheduled international air services. Although a market access right fundamentally provides an opportunity to serve a market, it is also a limitation on market access because of its specifications. States limit market access for various reasons including to bring about some perceived balance in rights exchanged; to retain leverage for possible future exchanges; to avoid or minimize competitive impacts on their national carriers; to be precise in order to avoid misinterpretation; and to promote or favour some market segment (such as that of a particular city or national region). Ancillary rights, which relate to how an air carrier may conduct its business in a foreign State, are sometimes treated by States as elements of market access. These are identified and discussed separately in the manual.

Foreign investment or inward investment in the air carrier(s) of a State, including investment by foreign air carriers, i.e. the purchase of equity holdings with some possible degree of influence in management decisions if not control, is an additional means of obtaining market access. Yet another is that of obtaining a **right of establishment, i.e. the freedom to establish an air carrier in the territory of a foreign State.** Both additional means are in limited use in liberalized markets, either as exchanges between or among States or unilateral grants. (See also Chapter 4.4.)

This chapter uses a building block approach to identify and explain three types of basic market access rights which, in practice, States tend to intermix rather than keep separate in the annexes, articles, paragraphs and sentences of their air transport agreements and sometimes even intermingle with capacity or other subjects. The treatment accorded the many types of market access conditions and limitations in current use is fairly comprehensive; however, this chapter does not explore the topics of liberalization of market access, simplification of its regulation, or bilateralism versus multilateralism. Neither does it examine new concepts of **progressive liberalization in the grant of basic market access, i.e. the incremental removal of regulatory restraints,**

or of a **safety net, i.e. some regulatory arrangement for use in the exceptional event of a clear threat to the ability of a State to sustain some level of market participation.**

The first section of this chapter identifies various kinds of geographic specifications of the routes along which an air service may take place. The next section focuses on carrier designation and various specifications regarding the use of aircraft on such routes. The third section deals with specifications of categories of traffic that may be transported on the routes. The final section discusses market access as affected by the so-called “Sixth Freedom”.

ROUTE RIGHTS

A **route right** is a market access right which is expressed as an agreed geographic specification, or combination of geographic specifications, of the route or routes over which an air service or services may be held out and performed and of the order in which authorized places may be served. Generally, route rights are found in the route annex of an air transport or air services agreement between States, the annex itself setting forth separately a route or routes for use by the airline or airlines of each party to the agreement. In all following examples, “A” represents the State receiving the route right and “C” the State granting the route right (typically in exchange for a similar right or rights).

The most basic way of describing the grant of a route right to a State is to name one city in the territory of that State and a second city in the territory of the State granting the right, for example:

From City A1 to City C1.

The basic approach need not be limited to a single city in each State, for example:

From City A1 to City C1/City C2.

From City A1/City A2 to City C1.

From City A1/City A2 to City C1/City C2.

A **point** is a city, named or unnamed, on the route granted. The basic approach can be expanded to describe a route as:

From any point or points in State A to City C1.

A more expansive variation of the basic grant is:

From any point or points in State A to any point or points in State C.

An *intermediate point* is a point outside but between the territories of the granting and recipient States. (In exceptional cases, points within the territory of the recipient State lying along the general path of the route may be considered as intermediate points.) When the territories of the States involved in the grant are not adjacent and the territories and cities of other States lie between them, the route description may include an intermediate point or points, for example:

From City A1, via City B1, to City C1.

There are many other ways to indicate the grant of an intermediate point or points on a route with varying degrees of specificity, for example:

... **via City B1 and City X1** ...

... **via City B1, City B2 and City X1** ...

... **via State B** ...

... **via State B or State X** ...

... **via State B and State X** ...

... **via an intermediate point** ...

... **via two intermediate points** ...

... **via an intermediate point or points** ...

In the latter three examples, greater specificity may be achieved when desired by adding a particular continent, region, or country, for example:

... **via an intermediate point in Africa** ...

... **via two intermediate points in Europe** ...

... **via an intermediate point or points in the Indian Ocean** ...

The provision of an intermediate point or points on a route also serves to indicate a general direction that the route must follow. There may be an implicit or explicit expectation that the route employed on an actual operation

will be a reasonably direct one (between “A” and “C” in the examples). There may also be a desire to specify one general route in order to exclude another, for example:

... **via the South Pacific** ... to exclude ...
via the North Pacific ...

... **via a Polar route** ... to exclude ...
via a trans-Pacific route ...

... **via the North Atlantic** ... to exclude ...
via the mid-Atlantic ...

In lieu of various specifications, the parties may make a general grant of the right to serve intermediate points on any routes granted.

A *beyond point* is a point on a route which is generally more distant from the territory of the route recipient than the territory of the granting State (i.e. is situated beyond the latter) and which forms a part of a route description. For example, a basic route description for use by State A — from City A1, via City B1, to City C1 — may have added to it:

... **and beyond to City D1.**

... **and beyond to one (two) (three) point(s).**

... **and beyond to a point or points in Asia.**

Note that the latter example, apart from setting a general direction for continuation of the route, confines the beyond points to a single continent. Note also that the “beyond rights” on the route may be stated simply as:

... **and beyond.**

Additional flexibility may also be provided by allowing the air carrier operating the route to choose intermediate points, exchange them, omit them, or vary the order in which they are used. A *rover point* is an intermediate point, a second country destination point, or a beyond point to be chosen by the recipient State from among several named or unnamed points, the choice being notified to (and, if so stated, needing the concurrence of) the granting State, that choice then precluding service to other such points until some future change of points is made. For example:

... **and beyond to any two points to be chosen from among City X1, City X2, City Y1, City Y2 and City Z1.**

A route granted to a State in a traditional agreement is most likely to begin in the territory of the recipient State, follow a single general direction and be capable of being operated (and anticipated to be served) both outbound from the recipient State and inbound to it on a return service. A route granted to a State in an “open skies” agreement may well be described as beginning in or behind the territory of the home State. It is extremely rare for a route to be described for use in a single direction only, and when that occurs, it is likely to be for air freight service and to be either circular in structure or continuing around the world. In other unusual cases a State may be granted **cargo flexibility**, i.e. the right of a designated carrier or carriers to serve points outside the right-granting and right-receiving States with complete flexibility in the order of points served as intermediate and beyond points for the purpose of picking up and/or discharging international traffic in cargo and/or mail. It is much less unusual to allow a named point to be served either as an intermediate or as a beyond point (as in example route 7 on Table 4.1-1) on a given flight, particularly where relatively little deviation from the general path of the route is involved.

The majority of route descriptions in bilateral agreements are in sentence form. However, numerous route exchanges use an alternative tabular format as shown in Table 4.1-1.

A **behind point** is any point outside the route as described and usually geographically “behind” the

beginning point or points of the route. “Behind points” can be points within the territory of the route recipient and/or points in third countries. They are usually not included in traditional route descriptions. However, there may be an explicit or implicit understanding that either or both kinds of behind points may be served (explicit regarding third country behind points in typical “open skies” agreements), and the through service held out and advertised as such. Alternatively, such services involving points in third countries may be subject to conditions or be proscribed.

Other terms used in route right grants include:

- **gateway** or **gateway point**, i.e. any point of last departure/first arrival of an air service in the territory of the recipient State or the granting State;
- **route terminal** or **terminal point**, which may be a gateway or gateway point or a behind point;
- **co-terminal** or **co-terminal point**, i.e. any one of two or more points on the same route and in the same territory (of the recipient State or of the granting State) which may be served separately or in combination on any service over the route;
- **double tracking**, a term borrowed from the railroad industry to describe establishing a **double track route**, i.e. a route for use by a carrier or carriers designated by one State party to a bilateral agree-

Table 4.1-1. Routes for State A (tabular format)

Route	Points in State A	Intermediate points	Points in State C	Beyond points
1	City A1		City C1	
2	City A2	City B1	City C1	
3	City A3 City A4		City C2 City C3	Country D
4	City A1	City B2	City C1	City D1
5	Any point or points in A	North Africa	Cities C1, C2, C3	One point
6	Any point or points in A	Middle East and South Asia	Any point or points in C	Australasia
7	City A3	City B2	City C1	City B2

ment which has a mirror-image counterpart route for use by a carrier or carriers designated by the other State party to such agreement; and

- **single tracking**, also a term borrowed from the railroad industry to describe establishing a **single track route**, i.e. a route for use by a carrier or carriers designated by one State party to a bilateral agreement which has no mirror-image counterpart route for use by a carrier or carriers designated by the other State party to such agreement. A route that has some sector that is not matched may still be considered as a double-tracked rather than single-tracked route if the principal sector between the two States is double-tracked.

OPERATIONAL RIGHTS

An **operational right** is a market access right which is expressed as an agreed physical specification of how many carriers may be designated; of how aircraft may be operated; or of what aircraft types, parts of aircraft, or substitute conveyances may be employed and assigned flight designators over an agreed route or routes. In practice, operational rights may be found in air transport agreements in the route annex, in various articles or in side understandings, or may or may not be implicitly included.

One of the most basic operational rights is that of carrier designation. **Designation** is the formal notification by one State to another State, usually by diplomatic note, of the name of an air carrier chosen by the designating State to use all or certain of the market access rights received by that State under its air transport agreement with the second State. Depending upon the terms of the relevant agreement, a designation may be made for use of any or all market access rights granted, for a particular route or routes or for a particular part of a route.

Single designation is the right to designate only one carrier (with an implicit right to substitute another carrier). **Dual designation** is the right to designate up to two carriers (with the right to substitute). **Multiple unlimited designation** is the right to designate any number of carriers. **Multiple controlled designation** is the right to designate a specified number of airlines in total or a certain number per route, per gateway, or per route sector (with the right to substitute).

Bilateral agreements usually do not contain the explicit right for one State to reject the other's designation, carrier choice being a sovereign right of the other State, but typically do include the right of the first State to deny, revoke, suspend, or impose conditions on operating authorizations for such designated airline on specific grounds. These grounds normally are limited to a failure to satisfy the requirement that substantial ownership and effective control of the airline be vested with the designating State or its nationals, or a failure to comply with the national laws and regulations (of the State receiving the designation) which are applicable to the operation of such services.

* * *

Operational rights which deal with how aircraft may be operated over an agreed route or routes include those of overflight, technical stop, optional omission of stops, mandatory stop, positioning flight, extra section flight and change of gauge.

An **overflight right** or **right of overflight** is the right or privilege granted to a State of flying across the territory of the State making the grant, without landing, on a scheduled or other than scheduled international air service. The International Air Services Transit Agreement identifies the related term of **First Freedom of the Air** — the right or privilege, in respect of scheduled international air services, granted by one State to another State or States to fly across its territory without landing (also known as a **First Freedom Right**).

A **technical stop right** or **right of technical stop** is the right or privilege granted to a State to land in the territory of the granting State for non-traffic purposes, on a scheduled or other than scheduled international air service. This right is most commonly exercised to refuel the aircraft, to make unexpected essential repairs or to respond to some emergency need to land the aircraft. It may also be used in some instances to carry out the national entry requirements of a State before proceeding to a traffic point in that State. Even though a technical stop is, by definition, not made for traffic purposes, it may be necessary or desirable to discharge traffic for a time (even for an overnight stay) with a requirement to reboard it for onward movement (which could be accomplished on a substitute aircraft or other conveyance). The International Air Services Transit Agreement identifies the related term of **Second Freedom of the Air** — the right or privilege, in respect of scheduled international air services, granted by one State to another State or States to land in its territory for non-traffic purposes (also known as a **Second Freedom Right**).

A **right of optional omission of stops** or **optional stop right** is a right or privilege, normally granted for use on a route, authorizing multiple traffic points, provided at least one stop is made in the recipient State and one in the granting State on each flight. For example: **Any point or points specified on the route may be omitted on any or all services at the option of the designated airline(s); however, all flights must originate or terminate in the territory of the Contracting party designating the airline(s).**

On the other hand, a **mandatory stop requirement** is used to clearly establish the general path of a route or to preclude a non-stop operation. The first use clarifies the intended extent of the grant. The second use provides protection for the granting State's national carrier(s) — the mandatory stop makes the service of the foreign carrier less attractive to traffic.

A **positioning flight** is, in the broad meaning of the term, any flight, whether revenue-earning or non-revenue, whether scheduled or other than scheduled, flown to position the aircraft to be used on some revenue-earning services and is also, in the narrow meaning of the term, any **ferry flight**, i.e. a non-revenue flight flown for a positioning or other purpose (such as to enable the aircraft to undergo maintenance).

An **extra section flight**, typically a **second section flight**, is a revenue flight in scheduled service operated to carry overflow traffic on essentially the same schedule as that of the flight being augmented. The terms “extra section” and “second (third, etc.) section” were borrowed from the railroad industry. The **right to operate extra section flights** is normally considered as implicit under air transport agreements even when capacity is predetermined; however, this right does not extend to operating extra services at times entirely unrelated to those of the basic flight being augmented.

A **change of gauge** is a change of aircraft, at an en-route point on an international flight outside the home territory of the carrier, to (on an outbound trip) or from (on an inbound trip) another aircraft having a smaller capacity. A **“Y” change of gauge** is a change of gauge to (outbound) or from (inbound) two such aircraft. A **“fan” change of gauge** is a change of gauge to (outbound) or from (inbound) more than two such aircraft. A **second-country change of gauge** is a change of gauge, as seen in the context of an air service relationship between two States, carried out in the territory of one bilateral partner State by an air carrier of the other bilateral partner State. A **third-country change of gauge** is a change of gauge, as seen in

the context of an air service relationship between two States, carried out in the territory of a third State, which is included in an authorized international route.

A change of gauge enables an air carrier to operate more economically over international route sectors distant from its home territory by more closely matching the capacity of its flights on such sectors to the lower volumes of traffic to and from its home State normally expected in the case of the more remote sectors of a long-haul route. The international term “change of gauge” is not applied to a change of aircraft within the home territory of the carrier in that such change is domestic or national in character and under the sole jurisdiction of the sovereign State involved. Nor is any change of aircraft, wherever made, to one of the same size or capacity considered to be a change of gauge. Historically, the term “change of gauge” derives from the railroad term for the changing, at an en-route point on a rail route, from operations over tracks with one fixed distance (or gauge) between the two rails to operations over tracks with a different gauge, usually undertaken by replacing the wheel units (bogies or trucks) with those of appropriate gauge for the onward movement of the train.

A bilateral air services agreement may not specifically mention change of gauge because one or both partner States may consider it as implicitly allowed or disallowed; alternatively, it may be expressly provided for under specified conditions or it may be expressly prohibited. When States agree to specify the right of change of gauge in a bilateral air services agreement, they are likely to include an operational right grant along the lines of the following provision and one of the five options below:

An air carrier designated by one Contracting party may make a change of gauge in the territory of the other Contracting party, or at a point on the specified route intermediate to or beyond the territory of the other Contracting party, provided that:

option (a)

operations beyond the point of change of gauge shall be with an aircraft having a capacity less, for an outbound service, or more, for a service returning to its home territory, than that of the arriving aircraft;

or option (b)

operations beyond the point of change of gauge shall be with one aircraft having a capacity, or with two aircraft having a combined capacity, less, for an outbound service, or more, for a service returning to its home territory, than that of the arriving aircraft;

or option (c)

operations beyond the point of change of gauge shall be with one or two aircraft each having a capacity less, for an outbound service, or more, for a service returning to its home territory, than that of the arriving aircraft;

or option (d)

operations beyond the point of change of gauge shall be with any number of aircraft, each having a capacity less, for an outbound service, or more, for a service returning to its home territory, than that of the arriving aircraft;

or option (e)

for an outbound service, operations beyond the point of change of gauge are the continuation of a service from the territory of the Contracting party which has designated the air carrier and, for an inbound service, a continuation of a service to such territory, in both cases without limitation as to type or number of aircraft, or capacity thereof, to and from such point.

* * *

Operational rights which are specifications of what aircraft types, parts of aircraft, or substitute conveyances may be employed and of what flight designators may be assigned take numerous forms.

As regards specifications of aircraft types, States may, for example, agree that certain rights may be exercised only with narrow-bodied aircraft, only with wide-bodied aircraft, only with “small” aircraft or “large” aircraft (as defined by the States concerned), only with all-cargo aircraft or only with combination (passenger/cargo) aircraft. Note that such specifications, while they affect capacity, are generally intended for purposes other than capacity regulation (for example, to preclude significant freight carriage on a route).

As regards parts of aircraft, States may, for example, proscribe the use of aircraft (such as a combination aircraft) to carry cargo on the main deck or may specify that cargo may be carried in the belly-hold only. Similarly, they may explicitly or tacitly agree that a service may be performed using *blocked space*, i.e. a number of passenger seats and/or specified cargo space purchased by an air carrier for the carriage of its traffic on an aircraft of a second air carrier. They may also agree to permit *codesharing*, i.e. the use of the flight designator code of one air carrier on a service performed by a second air carrier, whose service is

usually also identified (and may be required to be identified) as a service of, and being performed by, the second air carrier.

Codesharing, where authorized, may occur on any parts of a route and may involve a second country air carrier, a third country air carrier or a domestic air carrier. States may choose to grant and receive certain access rights that may be used solely on a codesharing basis. Generally, States will require that both carriers in a codesharing arrangement have proper authorization.

Codesharing and blocked-space arrangements are usually, but not always, found together. The use of codesharing permits the holding out and sale of transportation involving more than one airline (interline) as if it were transportation on one airline (online), in particular in an airline distribution system such as a computer reservation system. This topic is discussed in more detail in Chapter 4.8 of this manual.

Closely related to codesharing is the concept of *franchising*, i.e. the granting by an air carrier of a *franchise* or right to use various of its corporate identity elements (such as its flight designator code, livery and marketing symbols) to a *franchisee*, i.e. the entity granted the franchise to market or deliver its air service product, typically subject to standards and controls intended to maintain the quality desired by the *franchiser*, i.e. the entity granting the franchise. Unlike codesharing which has become a widespread practice for both domestic and international air services, franchising is still not common for international routes (see also Chapter 4.8 for more detailed discussion).

A joint service flight is a flight identified by the designator codes of two airlines that typically have agreed with each other to share revenues and/or costs with the concurrence of their respective States. Some States consider a joint service flight as a codesharing flight and some do not.

The aircraft used to exercise market access may be owned by the carrier or may be leased. The use of a leased aircraft may or may not entail a need for some special authorization to exercise a right of access. Generally, when an aircraft is performing the air service of one air carrier but is under the operating control of another air carrier, any State whose territory is involved has a right to require that both carriers have its authorization of the arrangement. Such State may also require that both the State of the air carrier in operational control of the aircraft and the State of the air carrier holding out the service have received from it a right of market access of the route involved. A more

detailed discussion of this topic including its safety and economic implications is presented in Chapter 4.7.

Aircraft interchange arrangements normally present no need for specific access rights, conditions or limitations. An **aircraft interchange** or **interchange flight** is a regularly scheduled, single-plane through service linking a route of one air carrier at the interchange point to a route of a second air carrier, with the same aircraft being crewed by and under the operational control of the respective authorized carrier on each route. An interchange provides passengers with the benefit of a single-plane service on what is essentially an interline operation and may provide additional benefits to the carriers involved in terms of better aircraft utilization.

An **intermodal right** is a right of access granted by a State for use by a designated carrier or carriers of another State to extend, substitute for or supplement air services by use of surface conveyances. Examples of **surface conveyances** used intermodally (along with their IATA general type designators) include **bus (BUS)**, **hovercraft (HOV)**, **launch (LCH)**, **limousine (LMO)**, **train (TRN)** and **truck/road feeder service (RFS)**. Specific market access rights and/or authorization by the air transport authority may or may not be required for the use of surface conveyances to carry traffic under air transport tickets or waybills, depending upon the circumstances of each case. In one example, the area in which a foreign air carrier may carry out its own pickup and delivery services may be limited by a State to a certain radius of the airport used. In a second example, an air carrier's international services to/from a particular State, when carried out entirely by surface conveyances, even when such services are assigned an air carrier designator code and "flight" numbers for product distribution purposes, may require the authorization of surface transport authorities only or, if carried out under a contract with an authorized surface carrier, may require no special authorization. In a third example, surface movements between two points of an air route authorized to the air carrier, which are held out as substitution for or supplementation of flights over the route, may be considered as utilizing the market access rights associated with the route and may be subject to air transport regulation.

TRAFFIC RIGHTS

A **traffic right** is a market access right which is expressed as an agreed physical or geographic specification, or

combination of specifications, of who or what may be transported over an authorized route or parts thereof in the aircraft (or substitute conveyance) authorized. Note, however, that the term **traffic rights** is, in one usage, applied collectively to have about the same meaning as market access rights.

The most basic way a traffic right is expressed as a physical specification is that of the right to transport **passengers, cargo and mail, separately or in any combination**. If the agreed right is limited to the carriage of **passengers only**, it would normally include implicitly the baggage or courier pouches accompanying passengers or couriers and could include unaccompanied baggage not shipped as air freight. Similarly, cargo normally means freight and express shipments; however, a right to carry **cargo only** of necessity includes human attendants when required, in particular for live cargo. Traffic rights encompass revenue traffic and certain non-revenue traffic (if under a passenger ticket, freight waybill or other appropriate documentation) such as the carrier's company cargo or company mail.

* * *

The most basic way traffic rights are expressed as geographic specifications is that of one of the freedoms of the air which relates to traffic (the first two freedoms being operational ones). Figure 4.1-1 provides a graphic representation of the Freedoms of the Air.

The **Third Freedom of the Air** is the right or privilege, in respect of scheduled international air services, granted by one State to another State to put down, in the territory of the first State, traffic coming from the home State of the carrier (also known as a **Third Freedom Right**).

The **Fourth Freedom of the Air** is the right or privilege, in respect of scheduled international air services, granted by one State to another State to take on, in the territory of the first State, traffic destined for the home State of the carrier (also known as a **Fourth Freedom Right**).

The **Fifth Freedom of the Air** is the right or privilege, in respect of scheduled international air services, granted by one State to another State to put down and to take on, in the territory of the first State, traffic coming from or destined to a third State (also known as a **Fifth Freedom Right**).

Difficulties arise in assigning a freedom classification to a particular movement or part of a movement because some States classify particular traffic movements by their

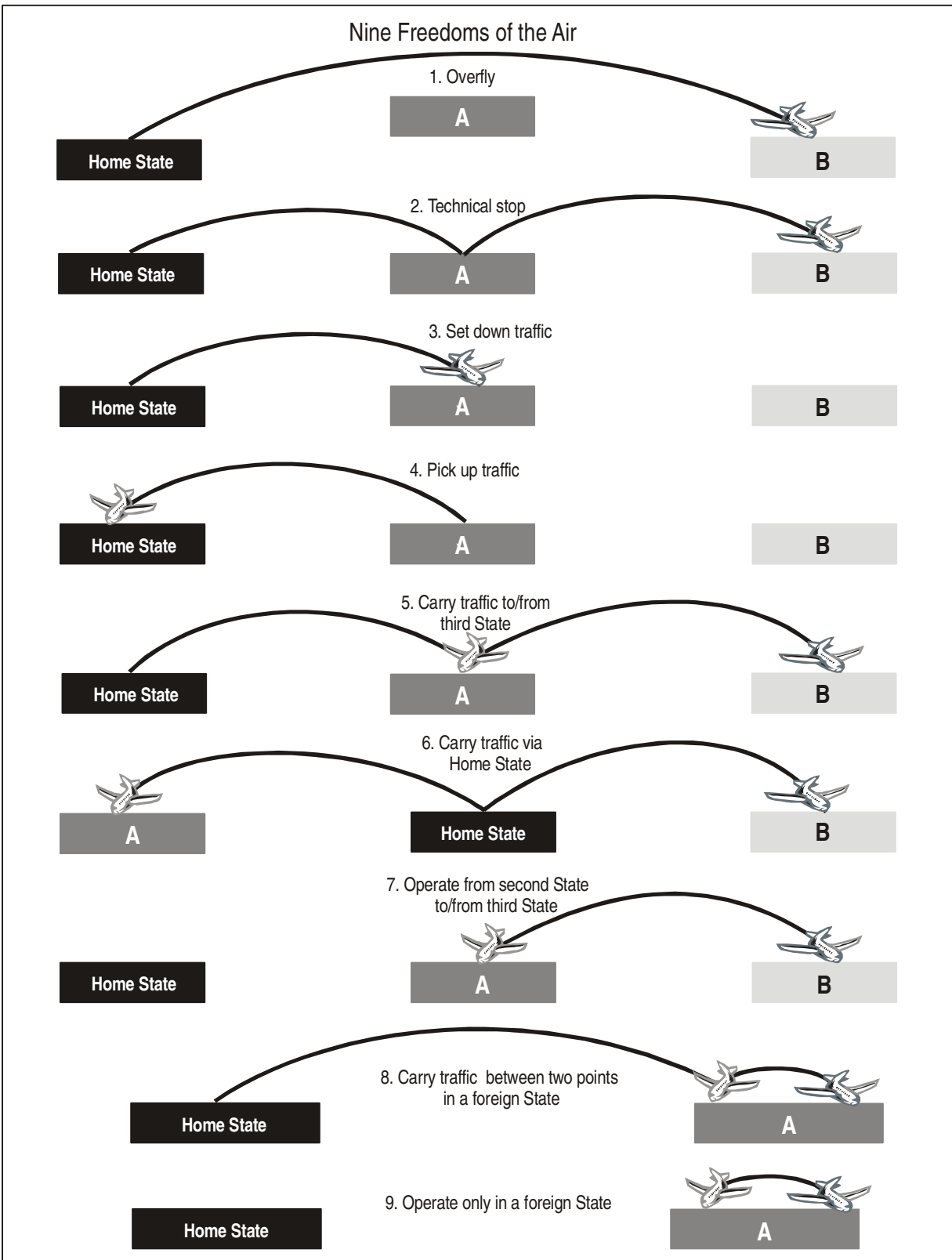

Figure 4.1-1. The Nine Freedoms of the Air

true origin and destination, i.e. **ticket or waybill origin and destination**, the origin being the first point named on the transportation document and the destination being the last point on a one-way movement or the point located furthest from the point of origin on a return (round trip) movement. Other States assign a freedom classification by **coupon or flight sector origin and destination**, i.e. the origin being any boarding point (initial or en route) at which traffic is first taken on board a particular flight and the destination being the first subsequent point at which it is put down (without regard to where the traffic initially began and ultimately will end its movement on the same ticket or waybill).

This difference in freedom classification under the two approaches can be seen in the case of a traffic movement that starts in State A and ends in State C with a flight change en route at State B, either directly or after a stop-over at State B, when there are three possible carriers: carrier AA of State A; carrier BB of State B; and carrier CC of State C. Note that using the true origin and destination method produces no change in freedom classification, even when a different carrier is used on each flight sector (see Figure 4.1-2), whereas the coupon or flight sector origin and destination method always produces a change in freedom classification (see Figure 4.1-3).

The so-called **Sixth Freedom of the Air** is the right or privilege, in respect of scheduled international air services, of transporting, via the home State of the carrier, traffic moving between two other States (also known as a **Sixth Freedom Right**). The so-called Sixth Freedom of the Air, unlike the first five freedoms, is not incorporated as such into any widely recognized air services agreement such as the “Five Freedoms Agreement”. It is a contentious subject which is discussed in the final part of this chapter.

The so-called **Seventh Freedom of the Air** is the right or privilege, in respect of scheduled international air services, granted by one State to another State, of transporting traffic between the territory of the granting State and any third State with no requirement to include on such operation any point in the territory of the recipient State, i.e. the service need not connect to or be an extension of any service to/from the home State of the carrier.

The terms **cabotage** and **cabotage traffic** in air transport usage:

- are derived, respectively, from maritime terms for the prohibition of coastwise carriage of traffic by foreign carriers and from the traffic thus prohibited

which could be equated with **domestic traffic**, i.e. traffic moving on a single transportation document (ticket or waybill) involving no origination, stop-over or termination outside the territory of one State;

- are sometimes expanded to also include (and thus prohibit) certain portions of international movements such as those between two points on an international route which are located in the territory of the same State (of which the carrier is not a national), before or after a connection or stopover at one such point, with an exception sometimes made to allow online on-route connections and stopovers;
- are sometimes erroneously applied to traffic moving between two States in the same group of States or economic union of States, when the group or union decides to reserve such traffic for its own air carriers; and
- can be applied to a traffic movement that constitutes *prima facie* cabotage such as a movement by air or surface across a national border followed immediately by a similar movement back across the same border, even when pursuant to separate tickets or waybills.

A **cabotage right** or **cabotage privilege** is a right or privilege, granted to a foreign State or a foreign carrier, to transport otherwise prohibited cabotage traffic. **Petit cabotage** involves traffic movements between two ports on the same coast of the same country (in maritime usage) and, by extension to air transport, between two airports in the same contiguous territory of a State. **Grand cabotage** involves traffic movements beginning and ending on different coasts of the same country (in maritime usage) and, by extension to air transport, movements between a State and a noncontiguous territory of that State.

The so-called **Eighth Freedom of the Air** is the right or privilege, in respect of scheduled international air services, of transporting cabotage traffic between two points in the territory of the granting State on a service which originates or terminates in the home territory of the foreign carrier or (in connection with the so-called Seventh Freedom of the Air) outside the territory of the granting State (also known as an **Eighth Freedom Right** or “consecutive cabotage”).

The so-called **Ninth Freedom of the Air** is the right or privilege of transporting cabotage traffic of the granting

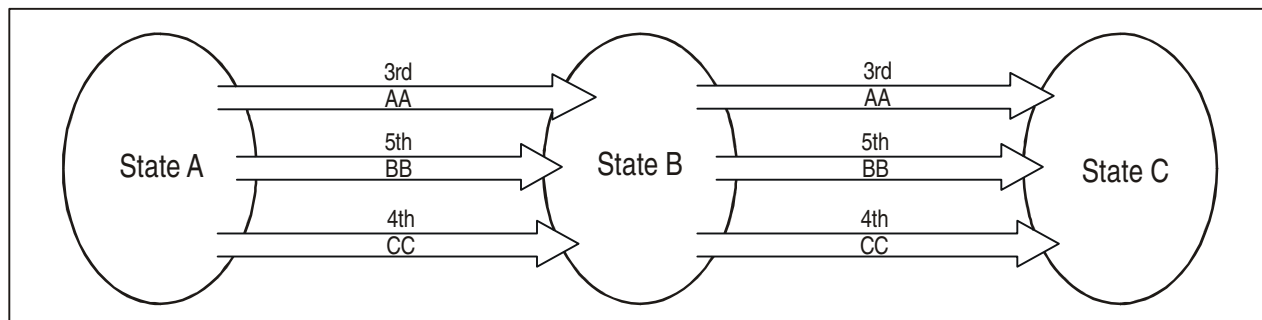

Figure 4.1-2. True origin and destination method

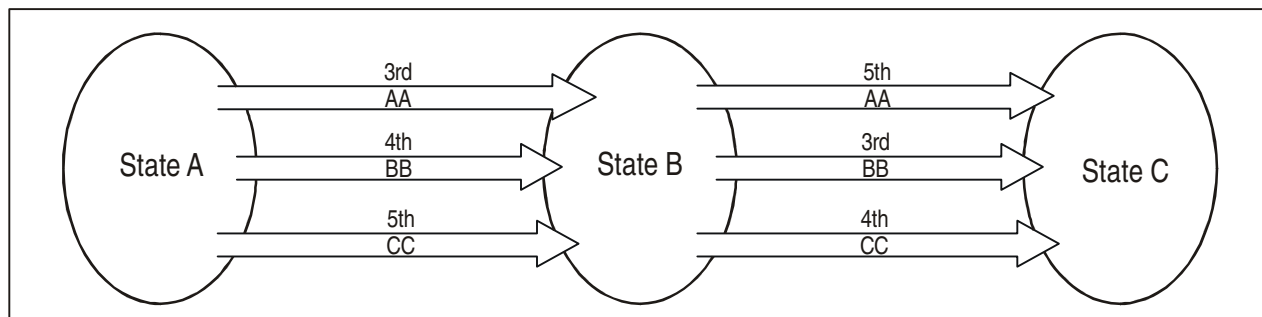

Figure 4.1-3. Coupon or flight sector origin and destination method

State on a service performed entirely within the territory of the granting State (also known as a **Ninth Freedom Right** or “stand alone” cabotage).

* * *

Another way by which traffic rights at a given point or in a given market are specified is by according different treatment (i.e. authorization or limitation) to enplaning traffic vis-à-vis direct transit traffic to be transported over a given flight sector. **Enplaning traffic** is traffic being taken on board a flight for the first time and consists of:

- **originating traffic**, i.e. traffic which is beginning its outbound movement by air or its return movement by air after a stay at its final outbound destination;
- **connecting traffic**, i.e. traffic which arrives at a point on one flight and departs the point (transits

the point) on another flight as part of a continuous movement under a single air ticket or waybill, without a stopover at the point; and

- **stopover traffic**, i.e. traffic which has taken a **stopover**, an intentional interruption of movement through a point under a single air ticket or waybill for a period of time beyond that required for direct transit through or, when changing flights, for a period normally extending to the departure time of the next connecting flight and (exceptionally) including an overnight stay. (Note that for the purpose of clarifying the number of stopovers that may be allowed for certain round trip travel, an airline may count the period spent at the final or most distant destination on such journey as a “stopover”.)

Direct transit traffic is traffic which both arrives and departs the point (transits the point) as part of a continuous

movement under a single air ticket or waybill, without a stopover, on the same or different aircraft identified by the same airline designator and flight number. A **flight sector** consists of any two points along a route at which a take-off and/or landing is made and may involve one or more **flight stage(s)**, i.e. operation of an aircraft from take-off to its next landing.

The right to enplane traffic may be denied or restricted on a particular flight sector or flight sectors other than the principal international flight sector of the route. On a two-sector or multi-sector route, the traffic that may be prohibited is all or some part of the enplaning traffic. When enplaning traffic is restricted, a “blind sector” or a “partial blind sector” is created. A **blind sector** is a flight sector for which no traffic may be enplaned. A **partial blind sector** is a flight sector for which only specified traffic may be enplaned, such as connecting and stopover traffic only or connecting traffic only. These two categories may be further limited to:

- **online stopover traffic**, i.e. stopover traffic which continues its onward movement (after the interruption of the journey) on the same airline, as distinct from **interline stopover traffic**, i.e. stopover traffic which continues its onward movement (after the interruption of the journey) on a different airline; and/or
- **online connecting traffic**, i.e. traffic connecting between aircraft identified by the same airline designator but different flight numbers, as distinct from **interline connecting traffic**, i.e. traffic connecting between aircraft identified by different airline designators and flight numbers. Note that “local traffic” is sometimes prohibited on a given flight sector. **Local traffic** is an ambiguous term and can signify all enplaning traffic or all originating traffic or all traffic other than **transit traffic**, i.e. direct (same flight number) transit traffic plus connecting traffic.

A blind sector or partial blind sector restriction on an international route inevitably limits the traffic opportunities of an air carrier, with resultant economic costs to its operation. A State, in its bilateral air service relationship with another State, may nevertheless insist on a blind sector or partial blind sector restriction between two points on an international route or routes of the other State to safeguard the revenues of its own carrier(s) (and possibly the carrier(s)’ pool partners), to reduce the value of the agreed route(s) for the other State so as to achieve some perceived

overall balance of benefits between the two States or, if both the points named are in its own territory, to impose a cabotage restriction.

Note that one State requires foreign air carriers to obtain the prior permission of its authorities to transport what it calls “**blind sector traffic**”, by which it means *traffic enplaned and deplaned on flight sectors between foreign countries that are “blind” only in the sense that they are not otherwise authorized by the agreed route description and the corresponding licence or permit granted by that State.*

Flight sectors entirely within a foreign country may or may not be blind sectors or partial blind sectors. For example, a carrier’s operation of a **circle flight**, i.e. a flight that initially serves one point in a second State, goes on to another point in that State, then returns to the home State of the carrier, is likely to entail the authorized deplanement of inbound international traffic and the enplanement of return international traffic bound at the first point, and the further deplanement of inbound international traffic and the enplanement of return international traffic at the second point. Similarly, if a State that determines the freedom classification of traffic by its initial origin and final destination, rather than by its coupon origin and destination, wishes to be consistent, it will treat online stopover, interline stopover, online connecting, and interline connecting traffic with a foreign initial origin or final destination as international traffic, rather than as cabotage traffic, and allow its carriage by second country air carriers on flight sectors within its territory.

**MARKET ACCESS AS AFFECTED
BY THE SO-CALLED
“SIXTH FREEDOM”**

In 1944 the Chicago Conference formally established only five “freedoms” of the air, two concerning aircraft operations and three involving movements of traffic. The three traffic-related freedoms, the Third, Fourth and Fifth Freedoms, encompassed the full range of possible opportunities for international carriage by air (although, as set forth in the International Air Transport Agreement, their exercise was limited to movement of traffic having both origin and destination in a signatory State on through services over a reasonably direct route to/from the carrier’s homeland). The creation of three such freedoms (distinguished from each other by the national origin and destination of the traffic) rather than of a single freedom to pick up and set down

international traffic in the territory of any signatory State encouraged subsequent development of the concept of “ownership” by pairs of States (and by extension by their airlines) of air traffic picked up in the territory of one and set down in the territory of the other. The Bermuda principles of 1946 strengthened that concept by establishing the primacy (and primary “ownership” claim) of each pair of States to such traffic and built upon it by relegating to a secondary and subsidiary role traffic picked up or set down in the territories of third States.

As carriers, routes and traffic volumes grew, so too did the opportunities for airlines to attract varying amounts of traffic moving between two foreign States via their home States. Given the further entrenchment of the concept of national “ownership” of traffic resulting from the bilateral process of exchanging market access rights, it was inevitable that the “freedom” classification of such “homeland bridge” traffic had to be established.

Rather than agree that this traffic between two foreign States constituted secondary Fifth Freedom traffic to which they may not be entitled, States whose airlines benefited from such homeland bridge carriage developed the concept of a new “freedom”, the so-called “Sixth Freedom of the Air”. (ICAO characterizes all “freedoms” beyond the Fifth as “so-called” because only the first five “freedoms” have been officially recognized as such by international treaty.) The creators of this new concept maintained that the so-called “Sixth Freedom” consisted of a combination of the Fourth and Third Freedoms. Thus, by this definition, the traffic originating in a second State moved as Fourth Freedom traffic to the homeland of the carrier, then as Third Freedom traffic to the State of final destination. In so doing, by this definition, the traffic was “primary” for the homeland bridge carrier on each segment of the passenger’s journey.

The second and third States involved, to the extent of their concern with this capture of some or much of “their” rightful traffic (and to the extent their own carrier(s) had few or no opportunities to attract homeland bridge traffic in other markets), had every incentive to maintain that the so-called “Sixth Freedom” was nothing more than “Fifth Freedom” and that such traffic could at best provide only a “secondary” justification for air service capacity provided by the homeland bridge carrier. By extension, this point of view contended that the “freedom” classification of a passenger should be determined by the ticket or “true” origin and destination, not the coupon/flight sector origin and destination. Those with the opposing point of view maintained the opposite position.

As the regulation of bilateral air transport developed, States concerned with the potential or actual diversion of “their” traffic by a homeland bridge carrier undertook various strategies to attempt to prevent, cope with, or end such diversion. These strategies included:

- declining to negotiate any routes to/from the homeland of the bridge carrier;
- severely limiting the capacity allowed the homeland bridge carrier if such routes were established;
- refusing to allow the homeland bridge carrier to participate in some or all discount tariffs authorized to their own carrier(s) in markets between their home territories;
- prohibiting the homeland bridge carrier from holding out and advertising any single-plane services on a so-called Sixth Freedom basis in their country;
- attempting to compromise by treating traffic having a “legitimate” stopover in the bridge carrier’s homeland for one or a few days more favourably than directly connecting traffic for capacity regulation purposes; and
- refusing to grant Fifth Freedom rights to the government of a homeland bridge carrier or limiting the ability of the carrier to exercise such rights.

Generally, such regulatory strategies were only marginally successful. The reasons for this included the difficulty in countering the natural inclinations of carriers to maximize their profitable carriage by seeking traffic from all sources, and the preference of air transport users (who are not concerned about esoteric concepts of “freedoms of the air” or of the national “ownership” of air traffic) to accomplish their travel in the most convenient manner, usually by movement on a single airline. (This inclination to use online rather than interline connections is reinforced when free overnight accommodations/tours, etc., are offered at the homeland base of a bridge carrier.)

Notwithstanding the above, the reasons why homeland bridge operations attract traffic, when they do, involve more than airline market promotion or passenger desires. A carrier can participate substantially in homeland bridge carriage only when two other factors are present: its home territory is geographically situated to permit it to do so, and the relevant traffic flows have certain characteristics.

The first factor, the geographic one, comes into play because only those States well situated on a reasonably direct routing between other States which originate or terminate significant traffic volumes have opportunities to serve as bridges. For example, airlines based in southern Africa, southern South America and Australia have virtually no “Sixth Freedom” opportunities because there is literally no place for them to find or take traffic behind their homelands. Carriers based in northeastern Asia can attract North America-East Asia/Southeast Asia traffic flows on a bridge basis. Carriers based in the Middle East, South Asia and Southeast Asia have opportunities to attract Europe-other South Asia/Southeast Asia and Australasia traffic. Carriers based in North America are best situated to attract the limited volumes of available Asia-South America traffic and some Europe-Latin America traffic. Western Europe-based carriers are best located to have access to the most bridge traffic flows, i.e. Africa to/from North America, South Asia/Middle East to/from North/South America, Eastern Europe to/from North/South America and other Western Europe to/from the rest of the world.

The geographic location of a carrier’s home base also plays a role in its ability to attract intraregional bridge traffic. Thus a carrier based at or near the centre of Western Europe is well placed to attract Baltic-Mediterranean traffic; one centre-based in North America to attract northern climate traffic to Mexico/Central America/Caribbean sun destinations; and one based in eastern Asia near the Tropic of Capricorn to attract Northeast Asia-Southeast Asia traffic.

The second factor is that of the volume of traffic or capacity on the flight sectors on either side of the bridge State relative to the direct second-third State flight sector size and strength. In the following diagrams the width of the sectors indicates relative traffic and/or airline capacity volumes; States A and C provide the origin/destination points for the traffic; State B constitutes the bridge and its carrier the homeland bridge carrier; price and airline preference factors are assumed to be neutral.

In Figure 4.1-4, a State B-based carrier (BB) is unlikely to attract sufficient A-C traffic away from carriers AA and CC to cause concern to either State A or State C, as long as both its AB and BC markets and services remain small relative to AC services.

In Figure 4.1-5, the relative thinness of the A-C traffic and services (in both directions) enhances the attractiveness of movement via State B on carrier BB. States A and C may have to wait until the A-C traffic volume merits direct service competitive with or better than that given via State B and its carrier BB. In some circumstances the movement of traffic via State B on carrier BB may stimulate the market sufficiently to actually encourage services between A and C by their respective airlines.

A third situation may pertain. Assume that the carriers of both States A and B have agreed access to the A-B originating/terminating traffic. Assume that State A’s geographic situation is near the far tip of a continent and its carrier thus has virtually no opportunity to attract any bridge traffic through its home base, but that State B’s geographic situation is such that its carrier can attract bridge traffic to numerous countries behind its home territory. The additional “flow” traffic thus gives State B’s carrier(s) a clear advantage in serving the A-B market.

In the situation portrayed in Figure 4.1-6, carrier AA could attempt to attract traffic moving via State B, but not without difficulties, because passengers generally prefer to move on a single carrier rather than on an interline basis. While difficulties are unlikely to be fully overcome, States and carriers are increasingly turning to relatively newer approaches such as codesharing, blocked-space arrangements and operating a second country hub which, properly used, can ameliorate the relative disadvantages of the non-bridge carriers. Because geographic facts are immutable, this problem and efforts to deal with it promise to be on the regulatory scene for some time.

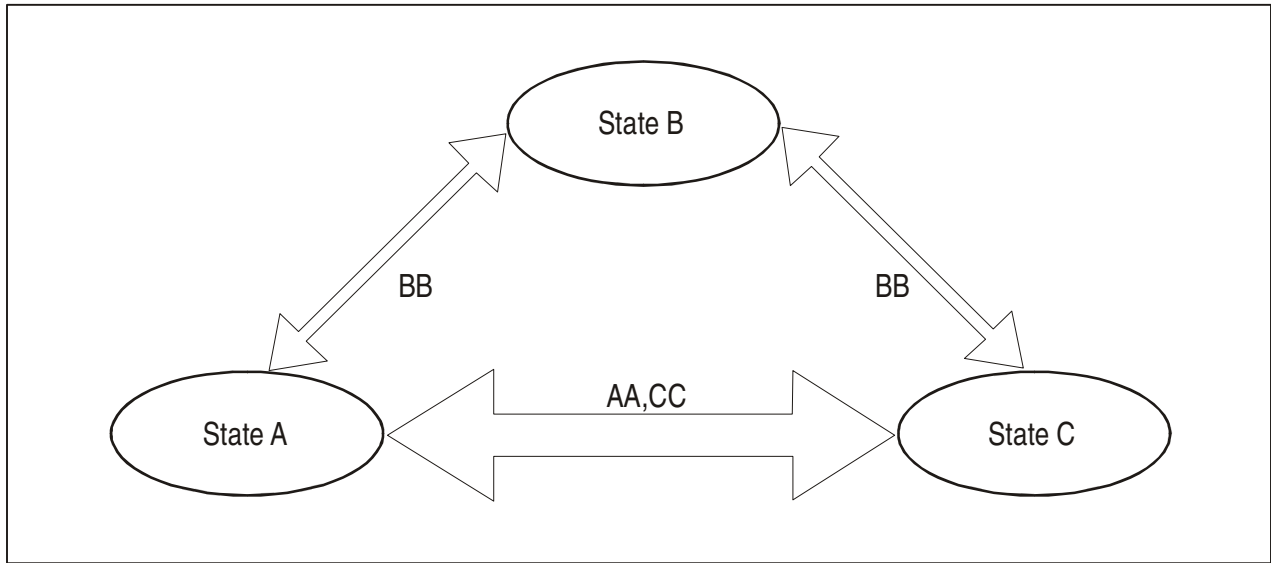

Figure 4.1-4

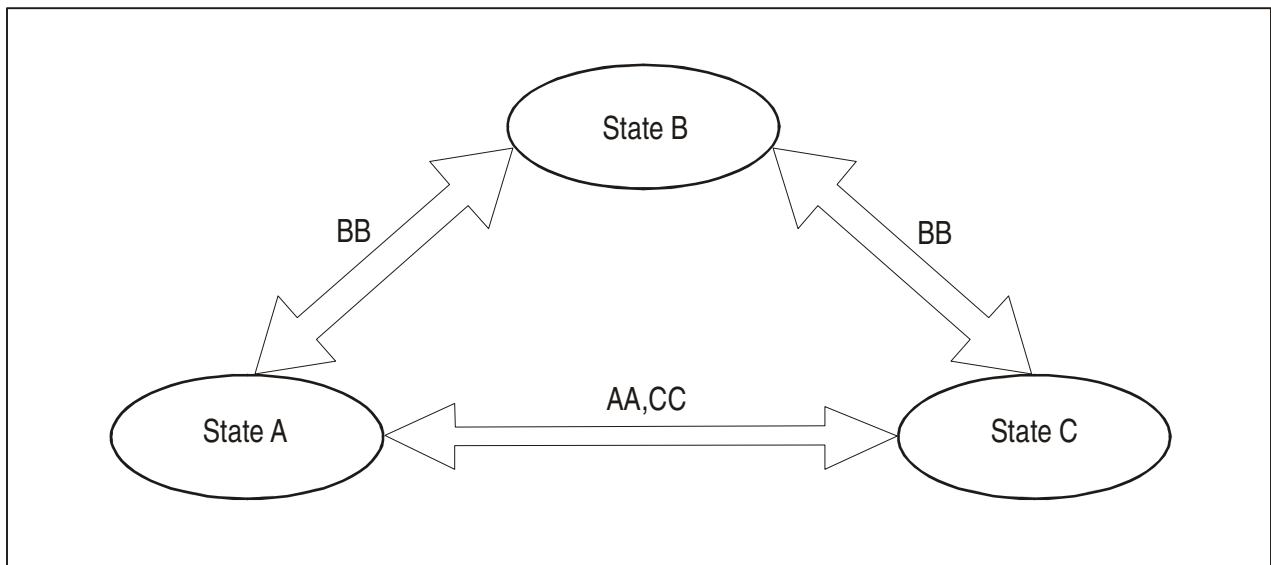

Figure 4.1-5

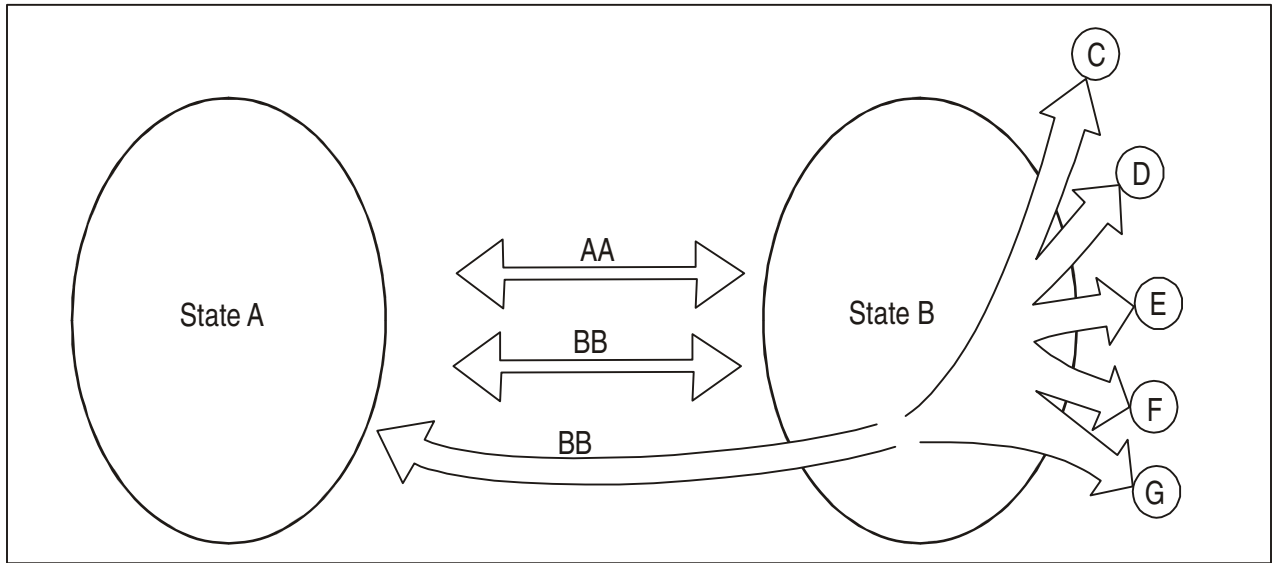

Figure 4.1-6

Chapter 4.2

AIR CARRIER CAPACITY

Air carrier capacity is the quantitative measure of air transport services offered or proposed to be offered by one or more air carriers in a city-pair or country-pair market or over a route. It may be expressed in terms of aircraft size, aircraft type, number of seats and/or cargo space (by weight and/or volume), frequency of operation, or some combination of such terms.

Capacity regulation is any method used by governments, separately or jointly, to control the capacity that is being or may be offered.

Although capacity regulation is a concern of both governments and airlines, it presents different issues for each, reflecting their different interests and concerns. The first section of this chapter describes the involvement of governments in air carrier capacity regulation. The next section presents capacity regulation from an air carrier perspective. When applied to an airport, capacity is usually measured in terms of the number of aircraft movements (i.e. take-offs or landings) the airport can safely accommodate in a specified period of time. Airport capacity can also be measured by passenger/freight throughput (expressed in passengers/freight tonnes per hour).

CAPACITY REGULATION BY GOVERNMENTS

Governments typically regulate the capacity of international air services through negotiation and implementation of their bilateral air transport agreements. States often consider international traffic originating in their territories as national property and as an article of international commerce which must be traded on the best possible terms, whether involving reciprocal rights or other considerations. In bilateral air services negotiations, this “ownership of traffic” concept has enabled States to claim a capacity share proportional to their homeland originating traffic in the

market and to treat such traffic between the bilateral partner States as “belonging” to them.

National governments generally view capacity in a broader context than do air carriers. Consequently, capacity regulation inevitably involves a wide spectrum of national interests extending beyond the economics of air transport. In making capacity decisions, governments must take into account national policy goals (such as promoting international trade, tourism and economic development) and their general responsibility for the public interest. For example, governments may want more capacity for passengers and/or cargo to be provided in certain areas or on certain routes than airlines believe economically justified.

National airlines designated to perform international air services are often regarded as national instruments or flag carriers and are treated as part business enterprise and part public utility. In this role, they may at times be required to operate in accordance with the needs of their country’s foreign or other general commercial policies rather than the needs of an economically viable air service. Thus, although States generally give high priority to the interests of their own national airlines, they must also bear in mind the air transport capacity requirements of their tourism industries and international trade.

Terms commonly used with respect to air carrier capacity and its regulation include the following:

- **load factor**, i.e. the percentage of available capacity that is actually sold and used by revenue passengers and/or freight, on a single flight over a single flight sector;
- **passenger load factor** or **seat factor**, i.e. the load factor applied solely to utilized passenger capacity;
- **average load factor**, i.e. the mean load factor achieved over a period of time, on a given flight, flight sector or route; in a particular market; or by a particular air carrier;

- **break-even load factor**, i.e. the load factor at which revenue achieved equals the operating cost, averaged to reflect results over a specified period of time;
- **authorized capacity**, i.e. the amount of capacity, determined by a regulating State or States, that may be operated on a specific flight or route, between city-pairs or between two States;
- **conversion factor** or **formula**, which is used to equate capacity when aircraft of different capacities are employed in circumstances in which frequency is used as the unit for capacity regulation by States seeking to maintain a strict balance in the capacity offered by competing airlines (for example, two B767 aircraft might be considered to have the same capacity as one B747 aircraft);
- **capacity allocation**, i.e. the amount of capacity each airline is permitted to operate when more than one designated airline from a State wishes to use the authorized capacity.

In developing capacity policy or positions for bilateral air services negotiations, which usually involve direct participation of or input from their national airlines, air transport regulatory authorities face three basic decisions:

- how capacity for each type of service (scheduled and non-scheduled, passenger, cargo, combination, etc.) will be regulated;
- how capacity will be apportioned among airlines providing those types of services; and
- how adjustments in capacity will be made.

As policies on commercial air transport regulation vary (sometimes widely) from State to State, the attitudes and approaches of States toward capacity regulation also differ. Over the last five decades, States have developed many forms of capacity regulation in their bilateral relations. However, the methods used fall into three basic categories, for which model clauses have been developed by ICAO as guidance to States and for possible inclusion in their bilateral agreements. Each model clause is accompanied by a set of criteria, related objectives and guidelines. (See Part 1, Section C, of Doc 9587.) The three categories are:

- the **predetermination method**, which requires that capacity be agreed upon prior to the commencement

of operation, either by governments or their aeronautical authorities, or between their designated airlines subject to governmental approval;

- the **Bermuda I type method**, which is a form of capacity control modelled after the one negotiated between the United Kingdom and the United States in Bermuda in 1946, in which the governments set out the capacity principles for the designated airlines to follow but allow each airline the freedom to determine its own capacity, subject only to *ex post facto* review by the governments through their consultation procedure; and
- the **free-determination method**, which allows capacity to be decided by air carriers free of government control, but may require each party to eliminate all forms of discrimination or unfair practices that would adversely affect competition.

In the bilateral negotiation of capacity regulation arrangements, difficulties are likely to arise between States with differing policies or views on:

- the interpretation of “reciprocity” and “fair and equal opportunity” to operate or compete; and/or
- the need for capacity to be predetermined and for air carrier coordination of capacity; and/or
- the probable effects of increasing or decreasing capacity (e.g. on load factor, yields and quality of service); and/or
- the provision and validity of traffic data as a means of determining capacity requirements; and/or
- non-aviation considerations involved in capacity negotiation (e.g. international trade balance, development of exports, tourism needs).

In such situations, the involved parties have to make compromises to narrow or overcome their differences, often resulting in agreements which contain combinations or variations of the three basic methods of capacity regulation. For example, some agreements on capacity reached by States after 1980 combine aspects of predetermination of capacity with the flexibility and rapid adjustment associated with the free-determination method. These arrangements essentially give air carriers freedom to determine capacity within predetermined limits. Included among the methods used are:

- giving advance approval for minimum levels of service (such as daily) and for annual or seasonal increases in the number of frequencies in specific city-pair markets;
- allowing an air carrier to operate a specified percentage, for example 150 per cent, of the capacity operated by competitor(s) from another State, or to match the capacity offered by competitor(s), or to operate the unused capacity assigned to another air carrier;
- allowing the capacity shares between airlines of each State on a route or city-pair to vary by up to, for example, forty per cent for one and sixty per cent for the other;
- utilizing formulas which provide for specified increases in capacity provided a certain average load factor is achieved during a specified period of time; and
- allowing air carriers to determine capacity provided that the aircraft used does not exceed a specified capacity (e.g. sixty seats).

One major problem in capacity regulation concerns the capacity for the carriage of Fifth Freedom traffic. Although the right to carry Fifth Freedom traffic is generally regarded as supplementary to that of the right to carry Third and Fourth Freedom traffic, it is at the same time considered by many to be essential to the economic viability of multi-stop international services. In bilateral negotiations, the State granting Fifth Freedom rights is often concerned about the potential effect of the capacity offered by the Fifth Freedom air carrier(s) of the other State on traffic to/from the third State which may be served by its national airline(s) on a Third and Fourth Freedom basis. The problem also stems from the fact that it is difficult to define precisely when the capacity offered by Fifth Freedom carrier(s) has become so substantial that it is no longer supplemental and is adversely affecting the Third and Fourth Freedom traffic share of national air carrier(s).

Regulation of scheduled and non-scheduled services in the same markets used to be a major problem to some States. In the 1960s and 1970s, non-scheduled services grew rapidly and had become quite important in some major markets (e.g. Europe and the North Atlantic), competing directly with scheduled services. The absence of an agreed capacity regime for non-scheduled operations aroused serious concerns among some governments and

scheduled air carriers. It was claimed that the significant capacity then offered by non-scheduled operators had or could have an adverse impact on scheduled air carriers and, therefore, should be subject to stricter control. To address the issue with a view to maintaining a reasonable balance between the involved interests, States developed several regulatory devices for authorizing capacity for non-scheduled services, including:

- permitting a fixed number of flights by type (passenger, cargo, combination) per year or per season;
- adopting directional ratios for specific markets per year or per season;
- using a criterion of no undue effect on scheduled services, while preserving a desired balance between scheduled and non-scheduled services;
- allowing air carriers operating non-scheduled services to operate only or primarily between points which do not have scheduled services;
- allowing air carriers to operate only certain types of non-scheduled flights (e.g. cargo, inclusive tour charters); and/or
- limiting non-scheduled capacity to a fixed percentage (e.g. 20 per cent) of scheduled service flights.

As liberalization progresses and along with the recognition that scheduled and non-scheduled services generally cater to distinct markets, the capacity of non-scheduled services has now become less of a regulatory issue. An additional factor has been the blurring of the regulatory distinction between the two types of services in certain markets.

**CAPACITY AS VIEWED BY
AIR CARRIERS**

Capacity is of vital operational and financial importance to air carriers mainly because of the nature of the commercial air transport business, which has several distinctive features in terms of the economics of its operations:

- the means of production (commercial transport aircraft) it uses are very expensive and must be utilized effectively to generate sufficient revenue to cover the investment;

- the product (passenger seats and cargo space) it offers is perishable (though in a sense renewable) and, unlike manufactured goods, cannot be stored because once an aircraft leaves the terminal, seats or space cannot be sold and are therefore lost; and
- the customers (passengers and freight shippers) it serves are time and/or price sensitive and have different service requirements.

As a consequence, the financial success of an air carrier will depend largely on how efficiently it utilizes its aircraft and how well it matches capacity to demand.

Where possible, air carriers seek to match capacity to traffic demand in order to maximize profits and minimize unused capacity on each flight. This is relatively easy for non-scheduled service operators, since the entire capacity of the aircraft (or major portions thereof) are usually sold (or contracted for) well in advance of operation. However, it can be very difficult for scheduled air carriers because:

- a scheduled service by definition must maintain a regular pattern of operation and generally is expected to fly according to the published timetable regardless of how much of the capacity has been sold;
- there is normally a need to provide sufficient capacity to cater to on-demand traffic (usually higher yield passengers) with seats which may be booked near or up to the time of departure;
- where a multiple stop service is involved, certain seats/space may need to be left vacant for use by en-route joining traffic;
- while traffic demand may vary by direction and time of day, operational constraints may require use of the same type of aircraft (with a fixed capacity) for all flights in both directions; and
- while increases or decreases in demand for a particular service often occur gradually and may not be concentrated at a specific day and time, capacity cannot be added or subtracted in small amounts, but only by an entire aircraft.

Due to these reasons, scheduled air carriers generally provide on average more capacity than the actual traffic (for example, the average passenger load factor worldwide for international scheduled services was 70 per cent in 2001).

Individual air carriers use historical experience and their best estimates of future demand as well as other techniques to determine the capacity to be offered on a route or in a particular market. However, scheduling the right amount of capacity can be difficult because the process is subject to, or complicated by, many factors outside the air carrier's control.

One significant factor is the regulatory regime within which the air carrier is operating. Certain aspects of the regime may inhibit its freedom of action. For example, the air carrier may be required to agree with its competitor(s) on the capacity to be offered on a route. Alternatively, it may be forbidden for competitors to agree on the capacity to be offered on a route. Desired capacity increases may need to be approved by government(s) and/or competitor(s).

A second and important factor is the nature of demand for international scheduled air services. Traffic demand can be affected by numerous factors, many of which are inter-related and some subject to regulatory constraints, such as:

- price (a tariff, if set too high, may discourage use, while a low tariff may result in a higher load factor but produce lower yields);
- frequency (a high frequency service which provides more choices could attract more users, but may not be economically viable on a route with a low volume of traffic);
- route structure (a multiple-stop service is not as attractive as a non-stop service serving the same two cities);
- service via a hub (the required en-route change of aircraft lessens the attraction although the increased frequency typically provided adds to the attraction);
- type of aircraft (passengers generally prefer a wide-body to a narrow-body aircraft, or a jet to a propeller aircraft);
- season (summer may see more people travelling than winter, warm destinations are more popular in winter; a pre-holiday period may produce more freight and a holiday period may produce more passengers);
- the state of the economies of each involved State and/or the regional or global economy (demand will be less during an economic recession);

- the security situation in the destination State which, if adverse, can reduce demand; and
- concerns about flight security in general.

A third factor is the capacity and pricing actions, actual and potential, of competing air carriers in the same market. In a competitive market, capacity becomes an essential means for an air carrier to maintain its market share. Where competing carriers are allowed to decide, independently, capacity and tariffs, there is a tendency that under competitive pressures each carrier seeks to operate more capacity than the other, or to match another's capacity in order to maximize or maintain its share of the traffic. This may lead to a situation of excessive capacity. Viewed strictly from the airline's standpoint, excessive capacity may not be considered to exist in terms of economics if the airline can achieve sufficient revenue to cover cost, even at a low load factor, for example 50 per cent. To individual air carriers, excessive supply means waste of product (i.e. empty seats/space) and tends to cause prices to go down, resulting in reduced yield and financial losses; conversely, inadequate capacity risks turning away passengers/shippers, hence losing potential sales.

Other factors which may have a potential impact on the demand and supply relationship include the availability of other capacity in the form of indirect routings between the involved States (e.g. services provided by Fifth Freedom or "Sixth Freedom" operators) or in the form of air charter operations and, in some cases, the availability of alternative means of transport, such as high-speed rail.

Yet another predicament for air carriers in adjusting capacity to demand is the lead time usually required to acquire new aircraft (i.e. new capacity). Air carriers usually order additional aircraft according to their forecast of future demand and arrange deliveries over a number of years. As demand has a close relationship to the performance of national economies, and collectively to the global economy, which influences airline traffic forecasts, air carriers tend to place their orders when the economy is growing or at its peak. However, because the performance of the economy is usually cyclical and sometimes beyond accurate prediction, it may happen that years later when the carriers' new capacity arrives, the economy is in a slump or at the bottom of the cycle and traffic demand has fallen off. To mitigate such situations, air carriers are increasingly adjusting their capacity by leasing aircraft, deferring delivery, or even cancelling orders.

Given all these features of the industry, air carriers generally deal with capacity in three ways. First, air carriers participate in, or seek to influence, government policy and decision making with respect to capacity regulation in order to secure a favourable regulatory environment and to ensure that their interests are taken into account. They also generally participate in the bilateral consultation process involving capacity arrangements and often rely on government assistance in solving capacity problems or settling disputes which they themselves are not able to resolve.

Second, in order to achieve optimum operating results, individual air carriers seek to enhance their aircraft capacity utilization through:

- better fleet planning based on more accurate traffic forecasts so that capacity will better match demand; and/or
- better scheduling, e.g. flying at user-preferred times to the extent possible, minimizing the ground time of an aircraft spent at arrival/departure gates, and otherwise maximizing aircraft utilization; and/or
- adjusting the **configuration**, i.e. the seating and/or cargo space arrangement of an aircraft to better cater to currently perceived market demands; for example, a passenger aircraft can be arranged to have a **multiple class seating** (e.g. first and/or business, and economy class), or a **single class seating** (e.g. business only or all economy class).

Optimum operation results may also be sought by employing **yield management**, a widely used form of **inventory control** involving the allocation and frequent adjustment of seat availability for the booking of each of many **booking classes** (fare types, e.g. normal economy, various discount tickets, free frequent flyer, etc.) and origin/destination combinations, in ways calculated to produce the maximum revenue for each flight sector at the fares offered. **Revenue management** adds close and ongoing coordination between the price managers who create the fares and yield managers.

Yet another tool to achieve optimum operating results is **overbooking**, i.e. accepting more reservations than the actual seating capacity of one or more classes of services on a given flight sector, typically placing some limits on the volume of overbooked seats, with the expectation that there will be a sufficient number of cancellations or "no shows" by departure time to avoid or minimize denied boarding with the passenger compensation costs it entails. When

actual denied boarding is about to occur the carrier will typically seek volunteers to give up their seats for compensation (such as a free future trip) and re-booking on a later flight, usually of the same carrier. Alternatively, a carrier may reduce or not utilize overbooking but employ *standby lists of potential passengers who, shortly before departure, may be assigned the seats of confirmed passengers who have failed to appear*. Costs can be reduced because standby passengers are not entitled to compensation; however, this can entail ensuring that the standby passenger's checked baggage/luggage is loaded, but only if the standby passenger is allowed to and does board the aircraft.

Third, air carriers coordinate among themselves, where permitted, capacity and tariffs on routes they operate so as to avoid excessive capacity supply and destructive competition or to obtain benefits from their alliance. Some air carriers also enter into *pooling arrangements, commercial agreements which may involve agreed capacity, conditions of operation, and the sharing between the parties of one or more of the elements of traffic, frequencies, equipment, revenues and costs*. Though this method has been endorsed and sometimes required by governments, it has now become less important in capacity regulation and is not permitted in an increasing number of markets.

Chapter 4.3

AIR CARRIER TARIFFS

Air carrier tariffs are one of the three major elements in the regulation of international air transport (the other two being market access and capacity), although their regulatory importance has gradually decreased along with the general trend of air transport liberalization.

ICAO has done extensive work on tariffs and developed relevant guidance which is reflected in Part 4 (International Fares and Rates) of *Policy and Guidance Material on the Economic Regulation of International Air Transport* (Doc 9587).

This chapter lists some of the reasons why States regulate tariffs, defines the term “tariff”, provides information on different types and characteristics of tariffs including terms and expressions used by the airline industry, describes methods for establishing tariffs as well as international and national regulatory mechanisms, and discusses some key tariff issues.

WHY STATES REGULATE TARIFFS

Among the reasons why a State regulates international tariffs are the following:

- to ensure that its national carrier or carriers have a fair opportunity to compete in providing international air services;
- to support pertinent national goals and objectives, such as encouraging international tourism and trade;
- to promote competition in international air transport by, for example, seeking flexibility for individual air carriers to use tariffs of their choice; and
- to respond to the needs of users of international air transport.

The types of tariff regimes States have developed reflect both their reasons for regulating tariffs and the fact that those reasons are often not shared by all States concerned. Thus, several tariff regimes are compromises which reflect the different reasons States have for regulating international air tariffs.

This situation, combined with air carrier efforts to use tariffs which respond to different markets and to different segments of the same market, has resulted in a complex system of international air tariffs which is described in more detail in the sections below.

DEFINITION OF TARIFF

The regulatory importance of how a tariff is defined lies in what aspects of pricing are included (and are therefore subject to the applicable international and national regimes) and what aspects are in effect left to air carriers’ commercial practices. A State’s definition of a tariff will therefore reflect the extent it wishes to regulate this aspect of international air transport. States wishing to control all aspects of tariffs will use a broad, all-encompassing definition. States wishing to liberalize air carriers’ pricing will use a more limited definition.

*A tariff is: 1) the price to be charged for the carriage of passengers, baggage or cargo (excluding mail) in air transportation, including any other mode of transportation in connection therewith, if applicable, charged by airlines, and the conditions governing its availability and use; and, in some States, 2) the document (also known as a **tariff filing**) containing such prices and conditions which a carrier or its agent files (either in electronic or paper form) with the appropriate regulatory authorities.*

An **international tariff** is for transportation between two or more States (and includes as well any domestic segment of an international journey); a **domestic tariff** is for transportation between two or more points of a single State. The international tariff between Canada and the United States is specifically called a **transborder tariff**.

Both international and domestic tariffs are divided into two categories, based on what is being transported. Generally, a **fare** is a tariff for the carriage of passengers and a **rate** is a tariff for the carriage of cargo. The term rate also applies to the charter of an entire aircraft or a part thereof (on scheduled services, referred to as blocked space).

The ICAO definition of an international tariff (see Doc 9587, Part 4) was developed with emphasis on scheduled services as well as with the aim to include all relevant areas while removing all areas of uncertainty as to what is encompassed by the term “tariff”. This definition includes a **tariff rule** or **condition**, i.e. an expressed restriction or condition governing the applicability of the tariff or the price for carriage.

There are two types of tariff rules. **General rules** are those which are applicable to many different types of tariffs, for example, fare/rate construction rules, currency conversion rules, refund and claims procedures, conditions of services, baggage allowances and excess baggage charges, reservation/ticketing conditions, rules of discounts, and denied boarding compensation. Each tariff filing will have reference to the general rules which apply to it. **Specific rules** are those which are associated with each fare and rate or those which override the general rules for a specific fare or rate. With respect to a passenger tariff, specific rules govern the elements of, *inter alia*, reservation/ticketing, length of stay (maximum and minimum stay), stopovers, transfers, fare combination, re-booking/re-routing, and cancellation (refund, if any).

In some cases, general rules contain **conditions of carriage**, i.e. the terms and conditions established by an air carrier in respect of its carriage. Conditions of carriage are incorporated by reference into **conditions of contract**, i.e. the terms and conditions shown on the travel documents, i.e. the **passenger ticket** or **freight air waybill**. Both conditions spell out the various benefits and limitations associated with the air transportation being provided. These benefits and limitations, along with the price, constitute a **contract for carriage** between the air carrier and the user. Often associated with the use of an air waybill are the term **consignee**, i.e. a person or an entity named as the receiver

of a shipment (one to whom the shipment is consigned) and the term **consignor**, i.e. one who designates the person or entity to whom goods are to be sent (usually the shipper).

The ICAO definition of “tariff” also includes **commissions** or **standard commissions**, i.e. a fixed public level of remuneration paid by an airline to intermediaries such as travel agents and freight forwarders/consolidators, and the conditions governing the applicability of the commission payment; any significant benefits provided to users, such as reduced rates on lodging and car rental, and **frequent flyer programmes**, in which members earn free or reduced fare transportation or other benefits on the basis of the amount of their travel on certain airlines or for their purchase of certain goods and services; and a **visit another country tariff**, i.e. a kind of domestic or international tariff not available in the country or region visited and sold only abroad in conjunction with an international carriage.

TYPES AND CHARACTERISTICS OF TARIFFS

In contrast to surface modes (such as rail and water), international air transport has developed a wide variety of tariffs for several reasons. For example, this variety may result from efforts by air carriers to fashion tariffs to respond to different markets as well as to different segments of the same market. The price disparity among air carriers may reflect the degree of competition and carriers’ relative strengths in the marketplace, which may depend on the network scale, flight schedules and frequency, market penetration, goodwill and service levels, etc., of each carrier. The prices maximizing revenue, therefore, may not be the same for each airline. In addition, States’ reasons for regulating tariffs and the different tariff regimes developed as a consequence have further complicated the international air tariff situation.

Passenger fares

There are broadly two types of passenger fares — published and unpublished — from the air carriers’ pricing perspective. A **published fare** or a **public fare** is a fare publicly displayed and distributed and if necessary filed with a government or governments for approval. An **unpublished fare** or a **private fare** (sometimes also called a **market fare** or an **off-tariff fare**) is a fare which is neither publicly distributed nor submitted to the government for approval. A published

fare is distinguished by the following five main criteria, which sometimes overlap.

First, there is a distinction based on how published fares are developed. An **IATA fare** is a published fare developed by the Traffic Conferences of the International Air Transport Association (IATA), while a **non-IATA fare** is any published fare other than an IATA fare. A non-IATA fare includes a **bilateral/multilateral fare** collectively determined through bilateral or regional tariff consultation among two or more airlines, a **government order fare** which is introduced by order of a government, and a so-called **carrier fare** which is determined individually based on each airline's judgement or is jointly determined by the cooperation of a group of allied airlines. Carrier fare usage has grown rapidly in recent years because of liberalization. The term **agreed fare** or **fare agreement** refers to both an IATA fare and a bilateral/multilateral fare.

Second, published fares can be classified in terms of the number of air carriers which transport the passenger. An **interline fare** or a **joint fare** is one which applies for interline carriage and which is published as a single amount, while an **online fare** or a **local fare** is one for transportation on one air carrier. The term **interlining** refers to transportation on more than one air carrier (see also the section on key tariff issues). All IATA fares, most bilateral/multilateral fares and government order fares, and some carrier fares (for example, alliance partners fares) are interline fares, although the scope of interlining may vary. Most carrier fares are online fares.

Third, there is a distinction of published fares in terms of the specification of a **through fare**, i.e. a total fare from point of origin to point of destination. In general, airlines specify through fares between a limited number of gateway city-pairs. The amount of each such **specified fare**, i.e. a through fare specifically set out either as a one-way fare or a round trip fare, is different depending on the point of origin from which the passenger's journey begins. Through fares for other city-pairs are constructed by combining a specified fare and an **add-on**, an **arbitrary** or a **proportional fare** which are specific amounts used only to construct unspecified through fares to be displayed and quoted. For example, normal fares from Tokyo to Montreal are constructed over Vancouver by combining a specified normal fare from Tokyo to Vancouver and an applicable add-on from Vancouver to Montreal. These unspecified through fares created by the use of add-ons are known as **constructed fares**. When there are neither specified fares nor applicable add-ons to create constructed fares from point of origin to destination, through fares can be constructed for

the purpose of applying fare construction rules by using the **lowest combination principle**, i.e. the lowest combination of separate specified fares or specified fare(s) and applicable domestic fare(s) over an intermediate ticketed point(s).

Fourth, there is also a distinction based on the routing control method. A **mileage fare** is a direct route fare governed by the mileage principle in calculating the applicable through fare amount for indirect travel. The **mileage principle** compares the passenger's actual itinerary or sum of each **ticketed point mileage (TPM)**, i.e. the shortest operated mileage between each sector, with the comparable **maximum permitted mileage (MPM)** from point of origin to destination, which is generally 120 per cent of the shortest operated mileage. If the sum of TPMs for each sector is less than the MPM from point of origin to destination, the direct route fare is used. If the sum of the TPMs is in excess of the MPM, a graduated table of percentages from 5 to 25 per cent is used to calculate a surcharge to be added to the direct route fare. In contrast, a **routing fare** or a **single-factor fare** is a direct route fare governed by the specified diagrammatic or linear routing, disregarding the mileage principle. As long as the passenger's itinerary is in line with the specified routing, a direct route fare can be used.

Fifth, published fares are divided into two general categories — normal and special — based on the availability of certain benefits and how they are priced. A **normal fare** is a fully flexible fare established for first-, business- (intermediate), or economy- (coach, sometimes also premium economy) class service, which allows maximum flexibility in terms of reservation/ticketing, length of stay, stopovers, transfers, fare combination, re-booking/re-routing and cancellation, etc. In some markets, there is also a **restricted normal fare** or a **point-to-point normal fare**, which retains most of the characteristics historically associated with normal fares but has restrictions, for example, on the availability or number of stopovers and, in some cases, on the ability to interline transfers. While a normal fare is regarded as a **bundled fare**, which includes all the primary facilities for the passenger for a single price, a restricted normal fare is regarded as an **unbundled fare**, one which is based on the provision of point-to-point travel only with additional charges for use of extra facilities such as stopovers and transfers

A **special fare** is any fare other than a normal fare. There are two types of special fares — non-promotional and promotional. A **non-promotional-type special fare** or a **status fare** is a discount fare the availability of which is

restricted to persons having specified personal attributes, such as student, youth, child, spouse, family, senior citizen, disabled, government official, military, seaman, voter, worker, refugee, emigrant, travel agent, airline employee, or pilgrim, some of which have traditionally been established by government orders. Status fares are targeted only to narrow groups of the population so that airlines can effectively minimize the number of passengers who would have previously paid higher-priced fares. In contrast, a **promotional-type special fare** is a discount fare available to anybody who can meet conditions on reservation/ticketing, length of stay, cancellation, etc. The restrictions attached to lower-priced fares act as “fences” to minimize the revenue dilution from higher-priced fares. The typical examples include:

- **excursion fare**, which is usually the highest and most flexible special fare but with some travel conditions such as restrictions on length of stay and stopovers;
- **special excursion fare (or instant purchase fare, public excursion fare, PEX fare)**, i.e. a special fare at a lower level but with more restrictive conditions than an excursion fare in terms of reservation/ticketing, length of stay, stopovers, re-booking/re-routing and cancellation, etc.;
- **advance purchase excursion fare (APEX fare)**, i.e. a special fare with the condition that the passenger books and pays for a ticket within a specified period of time before travel begins in addition to similar conditions to those of a PEX fare;
- **group inclusive tour fare (GIT fare)**, i.e. a special fare used by travel agents for groups of specified minimum sizes consisting of passengers who have purchased an inclusive tour; and
- **individual inclusive tour fare (IIT fare)**, i.e. a special fare used by travel agents for individual passenger travel as part of an inclusive tour.

In many markets, airlines apply **peak-load pricing**, i.e. pricing calculated to smooth the fluctuation of demand where peak hours/days are experienced. The level and availability of special fares, especially lower-priced ones, may have two or more seasonal variations known as **seasonalities** based on the time of year. Some normal and special fares also vary depending on the day of the week on which travel begins. Airlines also develop a **sell-up tariff**

structure, i.e. one with a stepped series of restricted, capacity-controlled special fares in addition to normal fares. The fares are arranged in booking classes for purposes of inventory control, and typically the lower the fare level, the more onerous the fare conditions. When the limited capacity devoted to the lower, more restrictive fare is filled, passengers are offered only higher, less restrictive fares. This dynamic seat allocation process is dealt by the latest yield management (revenue management) system, which aims to maximize revenue by ensuring that passengers buying lower special fares (mainly leisure passengers) are not allocated seats which passengers buying higher normal fares (mainly business passengers) might otherwise occupy (see Chapter 4.2).

Published fares are disseminated in paper format, such as tariff manuals and publications, and more widely in electronic format through the computer reservation systems (CRSs) and the Internet websites. For this purpose, most airlines use the electronic systems operated either by the Airline Tariff Publishing Company (ATPCO) or SITA (formerly Société Internationale de Télécommunications Aéronautiques), which collect information on published fares from airlines and distribute it to CRSs and tariff publishers and, in some cases, submit it to governments as a filing agent. Then, published fares are sold to passengers directly by airlines and indirectly through travel agents (including third-party websites) at the same prices without regard to where or by whom. Travel agents will receive standard commissions on published fares from the airline, though some airlines have abolished commissions altogether or for online sales.

In contrast to a published fare, an unpublished fare has a limitation on distribution and use, based on a special negotiation or contract deal between an airline and a travel agent (including a **consolidator**, i.e. an intermediary who purchases blocks of airline seats and resells them to other retail agencies and a **wholesaler**, i.e. an intermediary who coordinates air travel and land content and sells the package mostly to other travel agents), an electronic reservation service provider including an Internet website, or other entity such as a corporation and an organization.

Most unpublished fares fall into **negotiated fares**, i.e. unpublished fares which are offered selectively to customers and generally have three layers of linked fare amounts — gross, net and selling. A **gross fare** is a full amount of a published fare, which is often shown on the actual ticket's passenger coupon. A **net fare** or a **starting net** is an amount charged by an airline to a contracting

travel agent or other entity, exclusive of any commission paid at the **back end**, i.e. after the sales reports are processed. The net fare takes various forms from a specific flat rate to a fixed amount (so-called knock-off value) deduction or a percentage discount from gross fares. Airlines also usually pay a **commission override**, i.e. an amount over and above the standard commission according to route, sales volume, etc., as an incentive and bonus at the back end. The amount due to the airline after payment of all these back-end commissions, bonuses and incentives is called a **net/net**. A **selling fare** which a contracting travel agent offers to an end-customer is set at a price higher than a net fare, not only giving the agent its margin but also giving the end-customer a discount from the published fare.

The most prevailing unpublished fare is a so-called **discounted fare** or a **discount ticket**, i.e. a fare available only through travel agents at an amount below a gross fare. Discounted fares are rarely sold by consolidators and wholesalers, but by their retail agents including so-called **bucket shops**, i.e. no-frill smaller agents selling heavily discounted fares. Other examples of unpublished fares include contract discounts for corporations, bulk discounts for conventions and meetings, auction fares, promotional off-tariff products such as direct-mail special offers and upgrade coupons for customers. Recently, more airlines use ATPCO to disseminate their unpublished fare information that is transmitted only to their contracting travel agents and other entities.

Since an unpublished fare differs from any published fare with respect to fare level and/or conditions, some unpublished fares may constitute a **tariff malpractice**, i.e. excessive discounting, under certain jurisdictions. This raises a matter of **tariff enforcement**, i.e. measures taken to ensure that international air transport is sold only at approved prices and conditions. The particular regulatory focus has been placed on fares sold directly to passengers by airlines through the new distribution outlets. For example, some States believe that an **Internet fare** or a **Web fare**, i.e. a fare available only through the Internet, if it is offered via the websites of individual airlines or alliances, is no different from any other published fare and so require airlines to file such Internet fares for approval.

Cargo rates

Cargo rates have some of the same distinctions made with respect to passenger fares and are determined using similar pricing practices and concepts, but with different terminology. The **general cargo rate** varies with weight by applying

different prices per kilogram depending on whether the weight of the shipment falls above or below a **break point** which is a specified weight level at which the price per kilogram changes. General cargo rates do not vary according to the nature and value of the property transported and are used when the property being shipped does not qualify for any other cargo rate. As a reference for calculating other rates, the general cargo rate serves a similar purpose to a normal economy-class fare.

A rate which combines the pricing features of both premium and special fares is a **class rate**, one determined by applying a discount or surcharge to a general cargo rate for certain commodities (for example, a discount for newspapers and a surcharge for commodities requiring special treatment during shipment, such as livestock, gold and securities).

A rate which has a similar purpose to special fares is a **specific commodity rate**, used for certain types of cargo, which is generally lower in price than the general cargo rate at comparable weights but may also include restrictions (such as minimum shipment size). As in the case of special fares, airlines use restrictions to minimize the dilution of revenue from general cargo rates. Where more than one mode of transport is involved, fares for air/sea or air/rail transport are similar to the **intermodal rate**, i.e. the rate for the transportation of cargo by more than one mode (air, rail, road, maritime).

Some rates have no counterpart on the fares side. For example, a **container rate** is applied to cargo shipped in containers. Two container rates are: 1) a **ULD (unit load device) discount rate** which provides reductions on general cargo, class or specific commodity rates for cargo in owner-supplied and owner-packed containers; and 2) a **freight-all-kinds rate** which is not calculated by applying a discount or a surcharge to other rates but is determined separately and applied to cargo in airline-owned or shipper-owned containers.

Charter rates/fares

A **charter rate** is a tariff for the charter or lease of all or a part of the capacity of an aircraft. In contrast, a **charter fare** is the price charged an individual passenger on a charter flight by the charter organizer or charter tour operator. Charter fares have some of the characteristics of comparable fares on scheduled services. For example, a group inclusive tour charter fare and an individual inclusive charter fare are comparable to GIT and IIT fares on

scheduled services, although charter fares are usually lower and more restrictive, inter alia, in terms of changes in itinerary and refund availability.

**METHODS FOR
REGULATING TARIFFS**

There exist two different but interrelated regulatory mechanisms governing air carrier tariffs. The first one is an international framework based on the relevant tariff provisions of bilateral or multilateral air services agreements. The second one is a national tariff regulatory regime based on relevant national laws, regulations or policies, which each State applies to the tariffs used for the air services generally touching its territory.

International tariff regimes

In the bilateral or multilateral agreements, States have developed different tariff regimes based on how many States must approve a tariff before it becomes effective. These include *double approval* in which both States concerned must approve a tariff; *country of origin* in which only the State in which the transportation originates need approve the tariff; *double disapproval* or *dual disapproval* in which both States concerned must disapprove a tariff to prevent it from coming into effect; *flexible pricing zones* in which States agree to approve tariffs falling within a specified range of prices and meeting corresponding conditions (outside of the zone, one or a combination of the above-mentioned regimes may apply); and *free pricing* in which tariffs shall not be subject to the approval of any States, though some agreements may allow States to require notification of tariffs for informational purposes only. (Model clauses and explanatory notes for the double approval, country of origin and dual disapproval regimes are contained in Part 4 of Doc 9587.)

The traditional type of double approval regime has usually been accompanied by the requirement that designated airlines have to consult with other air carriers to develop an agreed tariff or a tariff agreement on all or part of the route, if necessary and possible. It also has required, implicitly or explicitly, that air carriers use an appropriate international rate fixing mechanism (often within the IATA Traffic Conferences) wherever possible. If the designated airlines cannot agree on tariffs, or if the required approval is not given to agreed tariffs, the States themselves seek agreement on the tariffs concerned. More recent bilateral

agreements, however, liberalize the procedure of double approval by relaxing such requirement. In this case, designated airlines are allowed to develop any tariffs unilaterally at their option, while the governments refrain from exercising disapproval authority unless filed tariffs are contrary to the pre-determined relevant factors.

Both regimes, country of origin and flexible pricing zones, generally have a transitional nature towards more liberal regimes such as double disapproval and free pricing. At the bilateral level, few agreements contain both these regimes. As explained below, flexible pricing zone arrangements are often adopted unilaterally at the State level. At the multilateral level, the country of origin regime has been introduced by two regional agreements — the Andean Pact in 1991 and the Forteleza Agreement in 1997. On the other hand, the zone pricing arrangement within the European Union was replaced by a free pricing regime in 1993, and one by the Memorandum of Understanding (MOU) on North Atlantic Pricing between the United States and member States of ECAC expired without further renewal in 1991.

The double disapproval regime allows the prices of air transportation to be established by each designated airline based upon commercial considerations in the marketplace. Unilateral intervention by each State is limited to, for example, prevention of predatory or discriminatory prices or practices, protection of consumers from prices that are unreasonably high or restrictive due to the abuse of a dominant position, and protection of airlines from prices that are artificially low due to direct or indirect governmental subsidy or support. Each State may request consultation with the other State regarding tariffs for which a notice of dissatisfaction has been given, but the tariff in question shall go into or continue in effect if mutual agreement is not reached.

There are also an increasing number of hybrid approaches of more than one regime. One example is a distinction between the approval process of passenger and cargo tariffs. In this approach, a liberal scheme is applied only to cargo tariffs. Another notable example of hybrid systems is a *country of designation* arrangement, under which each State agrees to follow double disapproval, country of origin or zone pricing schemes, subject to the condition that each State can unilaterally disallow any tariff in question filed by one of its own designated airlines. By taking this approach, even under the double disapproval regime, each State can effectively preserve its disapproval authority against its designated airlines' tariffs subject to certain conditions.

Some recent agreements also developed a *single disapproval regime*, under which one State may unilaterally disapprove a tariff, but only when it believes that such tariff is contrary to pre-established conditions. By nature, this regime is a variation of the double disapproval regime. The only difference is in that the tariff in question may not go into or continue in effect when States cannot reach mutual agreement during consultation. This regime can also be used in conjunction with the free pricing regime. For example, within the European Economic Area, community air carriers have been allowed to set their tariffs freely since 1993, but each member State can withdraw a *basic fare*, i.e. the lowest fully flexible fare available on a one-way and round trip basis, which is excessively high to the disadvantage of users. In a non-discriminatory way, a member State can also stop further fare decreases that would result in widespread losses among all air carriers on a route or group of routes for the air services concerned, taking into account the long-term fully allocated relevant costs of the air carriers.

National tariff policies and practices

Most States have national laws, regulations or policies for *evaluating tariffs* or *deciding whether to approve or disapprove tariffs filed by air carriers*. If a State chooses unilaterally not to exercise its right to regulate tariffs, that right would in effect pass to the bilateral or multilateral partners, leaving regulation in their hands. However, partners would have as their primary concern the interests of their airlines and users. It is therefore important for a State to be able to intervene, whenever necessary, to protect its interests under any bilateral and multilateral agreements.

Similar to the terms used in the bilateral or multilateral agreements, the terms used in the national laws, regulations or policies are generally vague and subjective in nature. For example, the term *predatory tariff* may be applied by a party alleging injury from a tariff such party believes is intended to drive it out from a market, yet predation is particularly difficult to define with any degree of certainty, and there is no definitive approach to distinguishing between anti- and normal competitive pricing actions. In order to avoid such ambiguity and administrative difficulties in implementation, some practical schemes have been developed. Examples are:

- limitation of *price leadership*, i.e. the ability to initiate new fares or changes in existing ones in a market. States sometimes commit themselves bilaterally or unilaterally to limit price leadership to air

carriers exercising Third and Fourth Freedom traffic rights, although the extent of price leadership or pricing flexibility they wish to permit varies. Price leadership by other air carriers is allowed on a case-by-case basis or on the condition of reciprocal treatment for their air carrier(s). In contrast, States generally approve *matching tariffs*, i.e. fares at the same level and with virtually similar conditions to those already approved for use in a market, for all air carriers including ones exercising Fifth, “Sixth” and “Seventh” Freedom rights;

- a *sum of sectors* policy, under which any through fare to or from a non-gateway behind point should be constructed as the sum of an international fare between gateway points and one or more domestic fares (or approved add-ons) between the gateway(s) and the behind point(s). The applicable domestic fare chosen (such as a published fare with the same conditions as the international fare with which it is combined) is one which can be used on an interline basis by the foreign State’s airline, thereby allowing it to compete for passengers in cities other than the gateway(s) it serves in another State. This policy is used by States that wish their air carriers to compete on an interline basis for traffic to and from cities in the territory of another State other than those being served directly by their air carriers. If this policy is strictly applied, *commonrating*, i.e. applying the same fare level to two or to more cities (e.g. Miami and Fort-Lauderdale), is not allowed even if the gateway and behind points are in general proximity to each other and approximately the same distance from the origin city; and
- various *zone fare systems* based on the concept of flexible pricing zones, the most detailed version relying on a series of so-called *zones of reasonableness* or *zones of flexibility* for different types of fares. A certain range of percentages relating to *reference levels* defines each zone, which in some cases has certain types of tariff conditions. Automatic or prompt approval is granted for fares falling within their appropriate bands and conforming to the prescribed conditions, though this approval does not guarantee the similar treatment by other States concerned. There are several derivative versions, for example, the so-called *fare-band system*, under which airlines are obliged to file a specified range of prices instead of actual selling levels for each fare that can be decided at their discretion without

*any further filing, and the **maximum tariff system**, under which airlines are obliged only to file a maximum level of fare, and at their option they can then sell, either directly or indirectly, at any price below that maximum level.* Both fare-band and maximum tariff systems are used by States that wish to legitimize discounted fares in the marketplace.

Processes for tariff approval/disapproval

The term **proposed tariff** is applied to a tariff in the initial phase of a government approval process. Filing or notification of tariffs may be required by applicable national laws, regulations or policies, and/or bilateral or multilateral agreements, except when a filing requirement is specifically exempted by them. A **statutory-notice filing** is a tariff filing with the appropriate authorities a specific period prior to its proposed effective date in accordance with the governing requirements. In contrast, a **short-notice filing** is a tariff filing in less than the statutory notice period, usually pursuant to permissive provisions in the governing requirements. In some recent bilateral and multilateral agreements containing dual disapproval or free pricing tariff regimes, States have agreed to dispense with the requirement for formal tariff filing altogether for their designated airlines. Even when States are allowed to require notification or filing of tariffs, such tariffs will be notified or filed for informational purposes only. Also some States unilaterally eliminate an entire tariff filing requirement or exempt a part of the requirement on a case-by-case or reciprocal basis in certain circumstances.

A few airlines file tariff material for themselves, but most use tariff agents such as ATPCO to handle the filing process. Airlines transmit their instructions to their agents, who have some discretionary authority to manipulate the data to comply with regulatory specifications. As for the tariff agreements resolved by IATA Traffic Conferences, depending on the States, filings are handled by national carriers or by IATA on behalf of the industry. For many years, tariff filing has been based on manual procedures. Generally, a page in a paper tariff manual is replaced by a new one whenever a single item on that page is changed. Faced with the sheer volume of tariff changes, some States have introduced an **electronic tariff filing system**, an automated system that enables airlines and their agents to transmit tariff changes to a central database via a telecommunication network or an Internet and to provide public access to tariff information in an electronic format.

The form of approval of tariffs by States may be either explicit, in which there is a specific action taken to approve tariffs; or tacit, in which tariffs are deemed approved if no negative action is taken within a specified period of time. Generally, the tariff agreements resolved by IATA Traffic Conferences are subject to explicit approval and to the clearance of applicable antitrust or competition laws. Once approved, the tariffs in such agreements may also have to be filed separately with governments to comply with the applicable national laws, regulations or policies. Disapproval is normally explicit.

Each tariff filing contains an **effective date**, the earliest date on which the tariff can be used for transportation, and a **selling date**, the earliest date on which the tariff may be sold. States often permit tariffs that have been filed, but not yet approved, to be sold subject to government approval (except IATA fares and rates which can be implemented only after receiving all the necessary States' approvals). An **approved tariff** has received the required regulatory approvals; it becomes an **established** or **effective tariff** on its effective date. Generally, established or effective tariffs remain in force until replaced by another approved tariff. Some tariffs, however, include **expiry dates**, a date beyond which the tariff may not be used, as a result of an airline's own volition, of multilateral tariff coordination, or because of a requirement of a State.

Since the late 1970s, many States have relaxed their regulatory control of air carrier tariffs, leaving pricing matters to each airline's discretion based on commercial considerations in the marketplace. The relaxation of tariff regulation, which is often regarded as one of the major elements of overall liberalization of international air transport regulation, might also be necessitated by States' administrative difficulties in exercising control due to the increased complexity and technicality of tariffs. In addition, the proliferation of unpublished fares has significantly undermined the effectiveness of the existing tariff regulations on published fares, which States might consider no longer appropriate or enforceable.

KEY TARIFF ISSUES

This section highlights four key issues in the current regulatory and competitive environments, namely multilateral tariff coordination, interlining, Internet fares, and predatory

pricing. The order of presentation of these key issues does not indicate their relative importance.

Multilateral tariff coordination

Tariff coordination or tariff consultation refers to the process by which two or more airlines negotiate passenger fare and cargo rate levels and conditions to develop and adopt agreed tariffs or tariff agreements for submission to governments for approval. The oldest and most widely used system of tariff coordination is that provided by the IATA Traffic Conferences (see Chapter 3.8). In addition, several regional airline associations, such as the African Airlines Association (AFRAA), the Arab Air Carriers Organization (AACO) and the International Association of Latin American Air Transport (AITAL), have taken actions involving, or related to, tariff coordination within their respective regions, often prior to meetings of the applicable IATA Traffic Conference.

The IATA system of multilateral tariff coordination has evolved over the years into a more flexible, transparent and less compulsory means of determining international interline tariffs. No tariff discussed gives rise to a binding agreement that must be implemented, and thus participating air carriers may file different tariffs. Under certain circumstances, air carriers that are not tariff coordination members may participate in the meeting. These changes, although required by States, also reflect a response to an increasingly competitive international air transport environment. Consequently, one issue is whether the changes in the process of multilateral tariff coordination will permit the IATA system to adapt to a more competitive environment or make it ultimately incapable of producing effective results which satisfy the needs of air carriers, consumers and governments.

Since inter-carrier activities through the IATA Traffic Conferences involve competitors cooperating, in some jurisdictions exemptions from competition laws have been granted, where necessary, especially recognizing the public benefit of the multilateral interline system. In recent years, however, more States have introduced competition laws or looked more closely at the application of existing rules to the IATA system. With the aim of mitigating the anti-competitive aspects of the process, some States, individually and collectively, have conditioned or limited their exercise (for example, by requiring that airlines participating in one of the immunized alliance agreements withdraw from IATA tariff coordination activities on certain country-pair routes, or that coordinated tariffs be available

to all airlines on an interline basis). This raises the issue of whether the IATA system can function effectively if one or more major air transport States choose not to authorize it in whole or in part. In 2001, IATA decided to end cargo tariff consultations for shipments between points in the European Economic Area after failing to secure exemption from competition law requirements for such activity from the European Commission.

Interlining

The interline system is a global network of scheduled international air transport services linking most cities in the world. On a worldwide basis, for a large proportion of journeys, the services of two or more airlines are necessary for a passenger to complete a single air trip. No single airline, no matter how large a network it may have, can serve every point in the world. Relatively few pairs of international cities have direct online air services. The rest depend on online or interline connecting services. The interline system provides choice and, in so doing, enhances competition. It is supported by agreed standards and procedures for inter-carrier reservations, ticketing, baggage, passenger/cargo handling and financial clearance. Technically, there exists two different types of interline methods: *IATA interlining* and *non-IATA interlining known as club interlining or bilateral interlining*.

IATA interlining occurs multilaterally based on IATA fares fixed at the same levels regardless of airline, which simplifies administrative procedures for the interchangeability of tickets. The revenues for interline carriage are prorated in accordance with either the *Multilateral Prorate Agreement (MPA)* operated by the IATA Prorate Agency or the *Special Prorate Agreement (SPA)* concluded individually by two or more airlines (Appendix 4 to this manual explains briefly how this is accomplished). The important point here is that almost all IATA carriers, including non-tariff coordinating members, assume that passengers using IATA fares can have a full interline privilege with generally high booking availability as long as the transporting carrier is a party to the Multilateral Interline Traffic Agreement (MITA) or has a bilateral interline traffic agreement with an *issuing carrier*, i.e. a carrier whose ticket is issued to the passenger. This industry commitment has served to facilitate a wide-ranging multilateral interline system, even though the actual membership does not cover all the airlines.

Non-IATA interlining occurs based on carrier fares even without any pre-agreements about fare levels and conditions

as well as scope of transporting carriers and available routing options. Routing is determined solely by the issuing carrier and thus the transporting carrier does not know it in advance (except in the case of joint fares determined by member airlines of an alliance where all the participating carriers know the fare levels and conditions in advance). The transporting carrier simply accepts any ticket issued by another carrier subscribing to MITA or bilateral interline traffic agreements (normally, except a voluntary change of carrier that is not written on the original coupons), and receives the prorate revenues for interline carriage from the issuing carrier in accordance with the MPA or SPA. If the transporting carrier finds its interline revenue too small after the accounting report is processed, then it would ultimately stop further acceptance of such interline tickets or limit the number of seats providing for interline carriage by downgrading the booking classes on an ad hoc basis. Compared to IATA interlining, the flexibility to change routing or use other carriers is therefore limited, but the fare levels are usually lower than IATA fares.

The issue here is whether tariff coordination through the IATA machinery is an indispensable element in order for the multilateral interline system to work efficiently, or whether the same or similar interline benefits from the current IATA tariff coordination could be secured by a less restrictive system. The proliferation of inter-carrier alliances and the liberalization of tariff setting are creating a rapidly changing competitive environment, with non-IATA interlining growing more popular. To respond to a decline in the scope of immunized activities through the IATA machinery and to enhance the attractiveness of IATA's multilateral interline system, IATA has developed the concept of *IATA standard premium service fares (SPS fares)*, i.e. *revamped and simplified IATA fares that guarantee a full multilateral interline privilege at levels more closely related to costs*.

Internet fares

Airline fares shown on the Internet come through different channels. Most of the fares shown are published fares distributed through the CRSs. Unpublished fares such as a contract discount for corporations and organizations are posted on the private websites of airlines and the CRSs, which are visible only to contracting travel agents and other entities who have negotiated them. Some travel agents' websites sell discounted fares on their own initiative. Airlines directly offer auction fares to bid-based websites. In addition, airlines sell Internet fares to the public, quite often lower than any other published and unpublished fares, exclusively on their own website and on specific third-party

websites in which they participate. Since airlines do not usually provide the CRSs with complete information on Internet fares, the CRSs do not display Internet fares as part of their normal offering to travel agents (but third-party search software allows travel agents to access a significant number of Internet fares).

Among the issues concerning Internet fares is whether travel agents should be given full access to Internet fares offered outside the CRSs. On the one hand, the airlines' refusal to make lower Internet fares available to travel agents through the CRSs and the lack of integrated information on Internet fares may be an impediment to the operations of travel agents, undermining the quality of services they provide to their customers in comparing fares and generating best travel options. On the other hand, airlines have traditionally made use of limited distribution channels to sell specific types of inventory to target market segments. Examples are unpublished fares, which are available only to contracting travel agents and some of which are not available in public retail channels. Internet fares are no different from these unpublished fares by nature. Mandating across-the-board access to Internet fares, therefore, would eliminate lower Internet fares altogether by discouraging airlines from marketing them.

Another contentious issue is a most-favoured nation (MFN) type of agreement between a specific third-party website and its participating airlines. Under such an agreement, participating airlines must provide a website in which they participate with all the Internet fares offered through their own website and other third-party websites. In theory, there is a potential risk that such an agreement might reduce competition and make competing distributors less attractive to consumers. For example, a MFN agreement may undercut the participating airlines' incentives to compete by offering lower Internet fares, and may also provide a convenient means for participating airlines to monitor each other's Internet fares, facilitating collaboration and coordination of their prices. Recent regulatory attention to third-party websites (particularly those jointly owned by groups of airlines) reflects these competition concerns.

Predatory pricing

The practice of predatory pricing had been regarded as a relatively unlikely or irrational event simply because it would be costly and not credible. Along with liberalization, however, more States have expressed their concern that a major airline with a dominant market position might reduce fares

specifically to drive out smaller rivals, or to discourage future entry, expecting to recoup any losses incurred by subsequently raising its fares above competitive levels. A dominant airline might also engage in predatory pricing to develop its reputation as a tough competitor and to send a “signal” to current and prospective rivals that the potential for profitable entry is slight. In addition, an airline, which receives a subsidy directly or indirectly from the State, could reduce their fares down to levels otherwise impossible to offer.

In dealing with predatory pricing through competition laws and consultation mechanisms, overly inclusive assessment rules may impose a restraint on the ability of airlines to compete vigorously on price, while a no-rule approach may have a risk of greater monopoly power or more collusion among competitors. Although there is no universally accepted clear-cut or so-called “bright-line” rule about what constitutes predatory pricing or how to prove its occurrence, many courts have used an *Areeda-Turner rule*, i.e. *a firm’s pricing is predatory if its price is less than its short-run marginal cost, i.e. an increment to cost that results from producing one more unit of output in a brief time period such that some factors of production cannot be varied without cost, or its average variable cost, i.e. a variable cost divided by output, as a more practical proxy.* In the airline industry, however, a short-run marginal cost of adding some extra passengers is close to zero at any given time once capacity is provided. Therefore, some have suggested the use of a *long-run marginal cost*, i.e. an

increment to cost in a sufficiently lengthy period of time such that all factors of production can be varied without cost, as a yardstick for judging predatory pricing. Since the longer the planning horizon the more likely it is that a fixed cost will become a variable cost, a marginal cost or an average variable cost becomes greater in the long-run.

In addition to these simple cost-based rules, several more complex rules have also been developed. For example, some argue that a firm’s pricing is predatory if its output is expanded in response to entry and its price is less than its average variable cost, while others suggest that a price cut made in response to entry is not predatory if a firm keeps its price for a considerable period of time after a new entrant has been driven off. There is also a two-tier approach that focusses first on market structures to examine whether predatory pricing is a workable strategy, followed by a number of cost-based tests.

Most of these rules which try to define illegal action can, however, be difficult to implement in a straightforward way because of the data limitations and the existence of related factors (such as capacity changes, yield management for seat allocation, sales and marketing activities). Given these difficulties, States (and groups of States) tend to rely on a *rule-of-reason approach*, which involves taking each case on its merits with a thorough examination of the factual circumstances such as market structures and dominant airlines’ conduct in a relevant market, as a starting point for assessing alleged cases (see Chapter 2.3).

Chapter 4.4

AIR CARRIER OWNERSHIP

States regulate air carrier ownership and control at the international level primarily in terms of discretionary criteria for licensing air carriers to use the market access rights granted under the relevant air services agreements. At the national level, regulation of air carrier ownership and control can have implications both for discretionary criteria and for other aspects of international air transport.

The first three sections describe the criteria traditionally used by States for airline designation and authorization, their use and some exceptions. The fourth section briefly discusses the implications of transnational investment in air carriers, and the last section examines some key issues in this area and possible ways to liberalize.

THE DISCRETIONARY CRITERIA

To establish an international air service, a State, under the bilateral regulatory regime, must not only secure the necessary market access rights from all its partner States but also their acceptance of the airline(s) it has designated to use those rights.

The criteria used by States in most bilateral air services agreements for airline designation and authorization have been that the airline must be substantially owned and effectively controlled by the designating State or its nationals. States also generally retain the right to withhold, revoke or impose conditions on the operating authorization if the foreign designated airline does not meet such criteria; however, use of this provision by the State receiving the designation is discretionary.

Some of the main reasons for this approach are that the criteria will allow a State:

- to refuse to authorize air services by air carriers owned or controlled by certain other States;

- to establish a link between the air carrier using international commercial rights and the State to which these rights pertain, thereby preventing a situation of potentially non-reciprocated benefits when an air carrier from one State uses another State's rights;
- to implement a balance of benefits policy in terms of the air carriers of the States involved;
- to ensure, in certain circumstances, that national air carriers do not use the rights of a foreign State to serve their own State.

With respect to regulation of airline ownership and control at the national level, many States, in their national legislation or regulations dealing with air carrier licensing or foreign investment, set statutory limits on permissible foreign ownership in national carriers (e.g. not more than 49 per cent). Some of the reasons for such rules include:

- national carrier(s) are considered to be a strategic asset;
- foreign-owned airlines should be excluded from the domestic market;
- aircraft of nationally owned firms are readily available for national defence or emergency needs.

USE OF THE CRITERIA

The use of the criteria for airline designation and authorization involves a two-fold test to determine:

- a) who has substantial ownership; and
- b) who exercises effective control.

In assessing what constitutes “substantial ownership”, States generally focus on the amount of ownership of the air carrier held by certain parties, usually considering that more than 50 per cent of the equity in an air carrier constitutes “substantial ownership”. States having a national law or regulation that specifies the percentage of equity in a national air carrier that may be held by non-nationals consider that ownership in excess of this specified limit is “substantial”.

Defining “effective control” has generally been more difficult than defining “substantial ownership” because, while ownership is usually transparent and can often be determined by public or other records of shareholders, effective control may be exercised in a variety of ways, many of which may not be readily apparent. Moreover, “effective control” may be exercised by different entities depending on the activity of the air carrier. For example, air carrier management may exercise effective control over certain operations, such as opening a new route, while financial entities, shareholders or a government might exercise effective control for the purpose of increasing the air carrier’s capital, merging it with another air carrier or dissolving the company. Consequently, some States have used the ability to take or to prevent certain actions (such as increasing the capital of the air carrier) as evidence of “effective control”. Most States rely on a case-by-case approach, using either the applicable national laws and regulations concerning corporate responsibility for decision making; or special laws, regulations and policies specifically related to determining who exercises control of air carriers, or a combination of the two.

SOME EXCEPTIONS

While the substantial ownership and effective control requirement are the most prevailing criteria used by States, some exceptions or deviations have long existed, including the following:

- Parties to the International Air Services Transit Agreement (IASTA) grant overflight rights for scheduled air services to an “air transport enterprise” that is substantially owned and effectively controlled by nationals of a Contracting State to the IASTA. (The text of the IASTA may be found in Doc 9587.)
- Multinational carriers created by intergovernmental agreement, such as the Scandinavian Airline System

(SAS) established by 3 Scandinavian countries; Air Afrique (now defunct) created by 11 African States; Gulf Air founded by 4 Middle East States. When one of these States wishes to designate their multinational air carrier to serve a third State, a modified ownership and control provision or other means can be used to ensure that the multinational air carrier will be authorized to use the commercial rights which the designating State has negotiated with that third State.

- A regulation of the Council of the European Union, effective 1 January 1993, allows a community air carrier (i.e. an air carrier majority owned and effectively controlled by member States of the Union and/or their nationals, with its principal place of business and registered office located in a member State) to operate air services anywhere within the European Common Aviation Area (ECAA).
- Under the Andean Pact (concluded by 5 Latin American States), an air carrier entitled to operate services within the Pact will be determined by national law of the Pact State designating the airline.
- The Caribbean Community Air Service Agreement requires that a CARICOM airline providing services under the agreement be owned and controlled by one or more member States or their nationals.
- The bilateral agreements involving Hong Kong, China, as a party allow the airlines designated by Hong Kong to be those which are incorporated and have their principal place of business in Hong Kong, China. The designated airlines of the other party may, however, be subjected to the traditional substantive ownership and effective control criteria.
- The plurilateral open skies agreement concluded by some APEC members in 2001 permits the designated airline of a party to be one whose effective control is vested in the designating party and is incorporated and has its principal place of business in the territory of the designating party. The traditional substantial ownership requirement is no longer a condition.
- The single aviation market (SAM) arrangement between Australia and New Zealand allows a “SAM carrier” (an air carrier at least 50 per cent owned and effectively controlled by Australian and/or New Zealand nationals, with its head office

and operational base in Australia or New Zealand) to operate air services within and between both countries, but with limits on beyond rights.

In addition, some States have used the discretionary right under the bilateral agreement to accept, on an ad hoc basis, foreign designated carriers that do not meet the traditional national ownership and control criteria, although usually this involves negotiated concessions as a *quid pro quo* for the acceptance.

**FOREIGN INVESTMENT IN
AIR CARRIERS**

The other area of airline ownership that has implications for international air transport is the extent of foreign ownership in national air carriers providing international air services. Where the extent of foreign ownership raises questions of substantial ownership and effective control, the discretionary criteria will be a factor. However, the extent of foreign ownership has other implications for international air transport which can also be present with or without the discretionary criteria.

Recently there has been increased activity and regulatory interest in foreign investment in national air carriers. Some of the reasons for this include:

- in some instances foreign international air carriers have acquired an equity interest through the privatization of formerly nationally owned air carriers;
- some international air carriers have made transnational investments in national air carriers as an indirect means of market access (for example, to increase their ability to compete to/from domestic cities beyond an international gateway through a closer relationship with a domestic carrier serving those domestic cities to and from the same gateway);
- in some instances, cooperative marketing arrangements, joint ventures, franchise operations, alliances and mergers between international air carriers or between international and domestic air carriers have involved transnational investment intended to increase both the effectiveness of the specific cooperative arrangements as well as the commercial benefits for all parties concerned.

Among the factors that States consider with respect to foreign investment in their national airline(s), other than the potential effect on the discretionary ownership and control criteria, are:

- the identity of the foreign investor; in particular, when it is an air carrier, what management expertise and commercial benefits might accompany the investment;
- reciprocity with respect to the State that is the source of the investment; and
- the potential effect on international air services including, for example, competition.

Individual States will apply these and other factors that are consistent with their particular goals for international air transport and the means chosen to achieve them. Attitudes toward the permissible limits of foreign investment in national air carriers will therefore vary widely, depending on the State and its specific circumstances.

KEY ISSUES

The traditional nationality-based ownership and control criteria were widely accepted during the time when most national carriers were owned by the designating State or its nationals, and viewed as having important strategic, economic and developmental roles. However, along with the trend of liberalization and globalization as well as regional economic unification since the late 1980s, significant changes have taken place in both the operating and regulatory environment of international air transport.

International air carriers have sought to adapt to increasing cost pressures, the need for capital, and heightened competition in a number of ways, including through cooperative arrangements such as airline alliances, codesharing, joint ventures and franchise operations, some of which have involved transnational investment (obtaining equity in air carriers from other States). Many States have adjusted their policies to relax restrictions on foreign investment in national carriers, particularly when privatizing them. Transnational investments in air carriers have also occurred against a backdrop of widespread multinational ownership in other service industries, for example, hotels and the travel industry.

As a result of these developments, the ownership of national air carriers has become increasingly diverse, many are no longer State-owned, and some are approaching the point where homeland nationals hold a bare majority of shares. However, most bilateral agreements including liberal open skies agreements have continued to use the traditional criteria. This phenomenon is seen by many as increasingly at odds with the changed global business environment in which the airline industry must operate. There is a growing call both from airlines and governments for regulatory change in this area and for the application of broadened criteria beyond national ownership and control to obtain market access.

From the perspective of an air carrier, the traditional criteria can pose severe limitations for its operations, for example, limiting capital sources, expansion opportunities or rationalization possibilities.

Some developing countries recognize that their economies and markets may not be able to sustain a national carrier without regional cooperation and/or outside capital. Others have adopted a policy of welcoming new services from all sources to promote tourism. Some developed States advocate change because they have policies aimed at developing the overall market and economy; many see a need for cross-border investment and industry rationalization; some others see more open rules as a means of creating competition for national carriers.

Liberalizing air carrier ownership and control could produce many benefits. For example, it could provide air carriers with wider access to capital markets and reduce their reliance on government support. It could permit airlines to build more extensive networks through mergers and acquisitions or alliances. It could also help improve economic efficiency of the airline industry by enabling more competitive carriers and a greater variety of services in the market, which in turn could feed through into consumer benefits.

At the same time, liberalization also carries certain risks which may be cause for concern, such as: the potential emergence of “flags of convenience” (explained below) in the absence of effective regulatory measures to prevent them; potential deterioration of safety and security standards with increasing emphasis on commercial outcomes; and possible flight of foreign capital which could lead to less stable operation.

There could be impacts on labour, national emergency requirements and assurance of service. Finally, and in the

long run, there may also be potential implications for airline competition as a consequence of industry concentration (i.e. the air transport system being dominated by a few mega-carriers through mergers or acquisitions), a reality that exists in most other service sectors. Therefore, when considering liberalization, each State needs to take into account all the benefits and risks.

From a regulatory perspective, the debate on liberalizing air carrier ownership and control in international air services has revolved mainly around two major issues: a) the link with the designating State; and b) the ability to liberalize.

As explained in the first section of this chapter, one of the main reasons for the traditional criteria is that it helps to establish the link between the carrier and the designating State. Under the current regulatory regime for international civil aviation, which is well established and has been functioning since 1944, the lack of, or weakening of, such a link could have both safety and economic implications.

On the safety side, a clear link is essential in maintaining safety standards because the Chicago Convention imposes upon each ICAO member State the responsibility for compliance with standards and practices related to safety and security, including regulatory oversight of its national carriers.

One main concern about liberalizing the traditional criteria is that it may lead to the possible emergence of “*flags of convenience*”, a term derived from the maritime industry which denotes a situation in which commercial vessels, owned by nationals of a State but registered in another State (i.e. the flag State) are allowed to operate freely between and among other States. As safety is of paramount importance in civil aviation, there is a need for safeguard measures to prevent any weakening of safety and security standards.

With respect to economic rights, there is concern that air carriers may improperly gain access under broadened criteria to routes which they would not be allowed to operate otherwise. Therefore, there is also a need to prevent “flags of convenience” in order to ensure an orderly economic regulatory regime.

With respect to the second issue, the ability to liberalize, the continuing use of the traditional criteria is seen by some States as a constraint to liberalization. It is argued that each State should be allowed to pursue air transport liberalization at its own choice and own pace, but the traditional provision, by virtue of the right of refusal held

by other States, effectively prevents a State which chooses to liberalize more rapidly from doing so in respect of airline designation for the use of market access.

In this regard, the current bilateral mechanism creates two distinctive yet interlocking issues for States: a) for those who wish to liberalize, how to remove the potential risk that their designated airlines might be rejected by the bilateral partners; and b) for those who want to retain the national ownership and control requirement for their own carriers, whether to accept foreign designated airlines with liberalized ownership and control, and if so, how to ensure that they could still identify the link between the airline and the designating State to prevent “flags of convenience”, and for matters of safety and security.

In the case of a), a State would be reluctant to liberalize if it might risk losing its traffic rights because of its designated airline’s foreign ownership. As for the case of b), the approach of the State to accepting designations can help or hinder the liberalization efforts of the designating States. A major challenge is how to have States that do not wish to liberalize at present not inhibit others from doing so.

The objective of regulatory liberalization in this area should be to create an operating environment in which air carriers can operate efficiently and economically without compromising safety and security. Liberalization should also help increase the participation opportunities of States, particularly developing countries, in international air transport while ensuring that change will not adversely affect the interest of all stakeholders.

There are a number of ways States can liberalize or facilitate the liberalization of air carrier ownership and control regulation. For example, States may mutually agree to apply certain broadened criteria for airline designation and authorization, including the following alternative arrangements developed by ICAO:

- The airline is and remains substantially owned and effectively controlled by the nationals of any one of more States that are parties to an agreement, or by one or more of the parties themselves.
- The airline is and remains substantially owned and effectively controlled by the nationals of any one of more States that are not necessarily parties to an agreement but are within a predefined group with a community of interest.
- The airline has its principal place of business and/or permanent residence in the territory of the designating State; and is under effective regulatory control by the designating State. In the context of this arrangement, the evidence of *principal place of business* may be predicated upon the following: *the airline is established and incorporated in the territory of the designating party in accordance with relevant national laws and regulations, has a substantial amount of its operations and capital investment in physical facilities in the territory of the designating party, pays income tax, registers and bases its aircraft there, and employs a significant number of nationals in managerial, technical and operational positions.*

The evidence of *effective regulatory control* may be predicated upon but is not limited to the following: *the airline holds a valid operating licence or permit issued by the licensing authority such as an air operator certificate (AOC), meets the criteria of the designating party for the operation of international air services, such as proof of financial health, ability to meet public interest requirements, obligations for assurance of service; and the designating party has and maintains safety and security oversight programmes in compliance with ICAO standards.*

States may also treat the ownership and control requirement of foreign designated airlines with more flexibility to accommodate the needs of other States wishing to liberalize in this area. Some of the measures a State may take include:

- allowing its bilateral partners to use the broadened criteria for those partners’ designated carriers while retaining the traditional criteria for its own designated carriers (such as that practised in the bilateral agreements involving the Hong Kong Special Administrative Region of China as a party);
- accepting the designated carriers of its bilateral partners which may not meet the traditional ownership and control criteria if that carrier meets other overriding requirements such as safety and security; and
- making public its position on the conditions under which it would accept foreign designations. Such information, when available from a large number of States (for example, via ICAO), would greatly enhance transparency and help bring about the certainty needed by governments, from the regulatory perspective, and the airlines for the planning and operation of international air services.

Chapter 4.5

AIR CARGO

Air cargo or *freight* refers to any property carried on an aircraft other than mail, stores and passenger baggage (see Annex 9 to the Convention on International Civil Aviation). The term air cargo is also used in a broader sense by the airline industry to mean any property (freight, express and mail) transported by air except baggage. An ***all-cargo service*** is an air service that carries cargo only, whether scheduled or non-scheduled.

In the field of international air transport, attention is often paid to passenger air services, yet air cargo is also an important component of air transport. To many States, air cargo services are important to their national development and international trade, for example, landlocked countries and States whose main export commodities are high value goods or perishables.

To freight shippers, air services render a competitive alternative to other forms of transport (rail, trucking or shipping) in meeting their shipping requirements in terms of speed, quality (much less en-route damage) and cost. As more companies adopt the philosophy of “***just in time***” (*i.e. goods arrive when needed for production or for use rather than being stockpiled and becoming expensive inventory*), aircraft will be used increasingly as, in effect, airborne extensions of warehouses in order to reduce inventory carrying cost.

To airlines, air cargo can be an important revenue generator. On some major international routes (e.g. across the North Atlantic, between Europe and Asia and across the North/Mid Pacific), air cargo has contributed roughly one-fifth of the total revenue on international scheduled air services.

A more recent development that adds importance to air cargo is the huge expansion of the ***courier*** and ***express/small package business***, which offers door-to-door air service for time-sensitive documents or small packages, usually with the delivery guaranteed within specified time limits (e.g. same day or next day) but subject to size or

weight limitations. Some airlines have also become more involved in door-to-door services, rather than limiting themselves to provision of the air component. Air cargo transportation has become increasingly integrated and globalized via cross-equity investments between airlines and cooperative arrangements such as ***co-branding*** (*i.e. a commercial arrangement under which involved air carriers market a service under one brand name, but carry out the operation with each carrier’s own aircraft bearing both the brand name and its own carrier identity*) and franchising.

This chapter identifies some distinct features of air cargo transportation and provides information on how governments regulate air cargo operations.

DISTINCT FEATURES OF AIR CARGO

Cargo, by nature, is generally less sensitive than passengers to time between origin and destination (except express), routes and stops. While passengers must be transported to their destinations without delay, cargo can often wait if space is not immediately available, can move on different routes and make numerous stops.

While passengers tend to make round trips, air cargo generally moves only one way. There are few routes where the volume of cargo traffic is the same or similar in both directions, but many where the volume is several times greater in one direction than the other.

Air cargo tends to use more ***intermodal transport***, *i.e. more than one form of transport, e.g. aeroplane, truck, rail or ship between origin and destination*. Special devices are often used for air cargo, such as standardized ***pallets*** (*i.e. platforms on which goods are assembled and secured by nets or straps*) and ***containers*** (*i.e. specially designed receptacles that fit in the cargo compartments of the wide-*

body aircraft) — such devices are often referred to by the generic term **ULDs (unit load devices)**. The use of these devices has not only helped enhance efficiency, but has also facilitated interlining and intermodal transport.

Most scheduled international airlines regard air cargo carried in the aircraft's lower deck compartment as an additional source of revenue, treating it as a by-product of their passenger services. However, air cargo can assume greater importance on a route with a sufficient volume of cargo traffic to justify using a combi aircraft (which carries both passengers and cargo on the main deck) and is the sole generator of revenue with respect to an all-cargo aircraft or a freighter.

Although airlines sell air cargo transportation directly to customers, a substantial proportion of their cargo sales activity involves intermediaries, such as:

- **cargo agents**, who act as retailers, selling air cargo transportation to shippers on behalf of airlines on a commission basis; and
- **freight consolidators/forwarders**, who act for shippers as forwarding agents (though some may also operate their own aircraft) and often consolidate shipments from more than one shipper into larger units which are tendered to airlines, benefiting from reduced freight rates for bulk shipments.

In many countries, commercial enterprises that are freight consolidators/forwarders are also cargo agents, although in some States this is prohibited by law.

REGULATION OF AIR CARGO

In terms of economic regulation of international air transport, air cargo transportation is generally treated as a component of government regulation with respect to market access, tariffs, capacity and non-scheduled operations, etc. These elements are examined in separate chapters of the manual.

Most governments traditionally regard air cargo as part of passenger air services, because most national airlines carry cargo in combination with their scheduled passenger services, with relatively few having all-cargo operations (e.g. in 2000, some 716 airlines provided international scheduled passenger services and about 91 operated international scheduled all-cargo services). Thus, in the bilateral

exchange of market access rights (discussed in Chapter 4.1), States typically grant the right for their designated airlines to transport passengers, cargo and mail on the agreed scheduled international air services. The right to operate all-cargo air services is generally considered as implicit in such grant, but some bilateral agreements are more specific, referring to “passengers, cargo and mail, separately or in any combination”.

Some bilateral air transport agreements assign special routes for all-cargo services. Recognizing the distinct nature of air cargo, some agreements provide for special route flexibility for all-cargo services, for example, by allowing the use of different intermediate points than those authorized for passenger or combination services, while permitting such services to be operated by the designated airlines on any combination service routes.

Government regulation on air carrier capacity (covered in Chapter 4.3) also extends to all-cargo operations, but tends to be less restrictive than that applied to passenger air services because cargo is generally of less concern to national airlines in terms of revenue generation and market share. Air transport regulators also deal with cargo rates as part of the government regulation of airline tariffs (see Chapter 4.2).

A great number of non-scheduled international air transport activities are all-cargo charter operations, such as those operated by or for freight forwarders/consolidators, couriers and express/small package services. These charter flights are regulated by States as part of the non-scheduled air transport services (see Chapter 4.6).

One major problem all-cargo operators experience is the lack of flexibility in market access rights under bilateral agreements in which air cargo is treated as part of passenger services. In such agreements, the limitations usually imposed on passenger services in respect of routes, traffic rights, frequency, etc., may also apply to all-cargo services. Since there are minimal synergies between passenger and cargo operations (e.g. different customers, different departure/arrival time requirements, directional imbalance of traffic movement), such regulatory restrictions often make it difficult for air carriers to sustain an economically viable all-cargo service.

Other regulatory problems all-cargo operators may encounter include:

- airport curfews which often limit the flexibility in flight scheduling, particularly for courier and express services which tend to wait until late in the

day to receive their shipments and operate overnight for next day delivery; and

- in some cases, limitation on airport slots that can be used by cargo flights, especially at congested airports where all-cargo operations are often given lower priority than passenger services.

As the air cargo market's size and importance grow, more States are adopting more flexible regulatory approaches that facilitate its development. ICAO has also developed guidance, in the form of model clauses for air transport agreements, for optional use by States in liberalizing air cargo services, which can be found in Doc 9587.

Chapter 4.6

NON-SCHEDULED AIR SERVICES

A **non-scheduled air service** is a commercial air transport service performed as other than a scheduled air service. A **charter flight** is a non-scheduled operation using a chartered aircraft. Though the terms non-scheduled and **charter** (i.e. a contractual arrangement between an air carrier and an entity hiring or leasing its aircraft) have come to be used interchangeably, it should be noted that not all commercial non-scheduled operations are charter flights.

Non-scheduled air services emerged as an important category of air carriage first in Europe, spreading later to North America and other regions. They experienced rapid development in the 1960s and 1970s, fostered by the growing demand for low-cost air travel. Though often considered by States as supplementary to scheduled services, non-scheduled services have been instrumental in some regions (notably in Europe) in the development of international mass tourism, which has assumed considerable economic and social importance for many countries, developed and developing.

Unlike scheduled international air services which are regulated primarily on the basis of bilateral agreements between States, non-scheduled international air services are generally authorized on the basis of national regulation. Although aviation regulators sometimes also regulate commercial non-transport operations (such as aerial crop dusting and surveying) as well as operations such as overflight and landing by private, corporate, military and State aircraft, whether for transport or not, these are outside the scope of this chapter and this manual.

The first section of this chapter describes some characteristics of non-scheduled air services which set them apart from scheduled services. The next section identifies the numerous kinds of international non-scheduled air services. The last section discusses how governments regulate international non-scheduled air services.

CHARACTERISTICS OF NON-SCHEDULED AIR SERVICES

Non-scheduled air services may be performed by all types of air carriers and may be distinguished from scheduled services by the following characteristics. They are usually operated:

- pursuant to a charter contract on a point-to-point and often plane-load basis (but several charterers may share the capacity of an aircraft);
- either on an ad hoc basis or on a regular but seasonal basis;
- not subject to the public service obligations that may be imposed upon scheduled air carriers such as the requirement to operate flights according to a published timetable regardless of load factor;
- with the financial risk for underutilized payload being assumed by the charterer rather than the aircraft operator;
- generally without the air carrier maintaining direct control over retail prices (the aircraft capacity is usually sold wholesale by the carrier to tour operators, freight forwarders or other entities); and
- subject to seeking permission, or giving prior notification, for each flight or series of flights, to/from the country of origin or destination or both.

KINDS OF INTERNATIONAL NON-SCHEDULED AIR SERVICES

Over the years, international non-scheduled air services have developed to meet changing air transport market

demands and the various regulatory environments. Indeed their evolution could be described as a demand inspired growth from a small base with fairly simple regulation into a sizeable field of air transport with more complex regulation. Their growth encouraged the development of liberalized scheduled air services, which in turn diminished both the non-scheduled market size and the complexity of its regulation. Thus many of the distinct types defined below have ceased to be used but the descriptions have been retained for historical purposes. The current and historical types fall into four categories.

The first category is passenger charter flights. Those that are open to the general public include:

- the **advance booking charter (ABC)** or **non-affinity group charter**, a charter whereby all or part of the passenger capacity of an aircraft is chartered by a **charter/travel organizer** who resells seats to the general public, subject to rules that are or were likely to include various requirements such as advance payment, pre-listing, minimum stay, cancellation penalties, stopover restrictions and other conditions;
- the **inclusive tour charter (ITC)**, a charter whereby all or part of an aircraft is chartered for the carriage of passengers who have purchased an inclusive tour from a **tour operator** (i.e. a travel organizer who resells seats in conjunction with accommodation and/or other ground arrangements for a comprehensive price); and
- the **public charter**, a generic charter type where capacity is sold to members of the general public through recognized intermediaries, often without regulatory requirements such as round trip, advance booking, etc.

Passenger charters that are or were open solely to eligible segments of the public or that are for the charterer's own use rather than resale include four types most often rendered obsolete by liberalization, namely:

- the **affinity group charter**, one chartered for the exclusive use of a group (or groups) consisting of members of an association or club having principal aims and objectives other than travel and sufficient affinity prior to the application for charter transportation to distinguish it and set it apart from the general public;

- the **common purpose charter**, one chartered by an organizer for resale to persons who share a common purpose in travel (such as attending a particular event) but are not necessarily members of any association or club;
- the **special event charter**, a charter for the carriage of people attending a special event of a religious, sporting, cultural, social, professional or other nature;
- the **student charter**, a charter bought entirely for the carriage of students at a recognized establishment of higher education, usually subject to certain age limitations; and
- the most basic and timeless type, the **single entity charter** or **own-use charter**, one chartered by one entity (e.g. an individual, corporation, government) solely for its own use for the carriage of passengers and/or freight, with the cost borne solely by that entity and not shared directly or indirectly by others.

The second category is cargo charter flights, including those that are chartered for resale purposes by freight forwarders, consolidators, shipper's associations, express/small package/courier services and similar charterers, and those for the charterer's own use rather than resale.

The third category is combinations or variants of the above, including:

- the **mixed passenger/cargo charter**, one used by the same charterer to carry both passengers and cargo (e.g. people attending a trade fair and exhibits); and
- the **split charter**, a charter involving more than one charterer where the capacity of the chartered aircraft is shared or split.

Also, two practices created other variants, namely that of **comingling**, i.e. carrying on the same flight more than one kind of passenger charter traffic, such as advance booking and inclusive tour; and **intermingling**, i.e. carrying on the same flight traffic originating its travel in the origin country of the round trip flight and traffic starting its travel in the destination country, both outmoded concepts where regulation has been liberalized.

The fourth category of international non-scheduled air services is non-scheduled non-charter flights for the carriage of individually ticketed or individually waybilled traffic

(sometimes referred to as on-demand air taxi service). These are flights not operated according to a published schedule but sold to individual members of the public (usually freight shippers). They fly authorized routes but only make stops at en-route points where there is traffic to be set down or picked up.

International non-scheduled air services are generally not considered to include certain scheduled services that may be confused with non-scheduled operations, such as:

- inaugural flights;
- positioning flights;
- extra sections of scheduled services;
- scheduled flights using wet-leased or dry-leased aircraft; and
- “part charters” on scheduled service flights. Note that a *part charter* is in effect a marketing method which allows part of a scheduled service flight (seats or space) to be sold in the manner of a charter service under a carrier-charterer contract.

**REGULATION OF
NON-SCHEDULED AIR SERVICES**

The Convention on International Civil Aviation (Chicago Convention) distinguishes between the rights to be accorded by Contracting States to international non-scheduled flights (Article 5) and to scheduled international air services (Article 6). It refers to non-scheduled flights as the flights of all aircraft “not engaged in scheduled international air services”. The first paragraph of Article 5 requires that each Contracting State grant the rights of transit and non-traffic stops to all international non-scheduled flights by aircraft of other Contracting States “without the necessity of obtaining prior permission”. The second paragraph of this Article states that commercial non-scheduled flights shall also “have the privilege of taking on or discharging passengers, cargo or mail, subject to the right of any State where such embarkation or discharge takes place to impose such regulations, conditions or limitations as it may consider desirable”. As a practical consequence of Article 5, the regulation of international non-scheduled services has generally been governed by rules laid down by individual States, with only a few bilateral and multilateral agreements existing to create joint regulation.

For the guidance of States in their interpretation or application of Articles 5 and 6 of the Chicago Convention, the Council of ICAO has developed a definition for the term “scheduled international air service” which is accompanied by “Notes on the Application of the Definition and an Analysis of the Rights Conferred by Article 5 of the Convention” (see Doc 9587). The Council recognized, when developing the definition, that the right of Contracting States to impose regulations, conditions and limitations on the taking on or discharging of passengers, cargo or mail by commercial non-scheduled air transport is unqualified. It has expressed the opinion, however, that it should be understood that the right would not be exercised in such a manner as to render the operation of this important form of air transport impossible or non-effective.

Under a unilateral framework where international non-scheduled/charter operations continue to be regulated, States of origin and destination regulate independently of each other such services between their territories. In this situation the charterer and carrier must follow the rules of both States for the operation to be *charterworthy*, i.e. being a valid charter under the relevant regulation. These rules generally appear in national laws, government regulations, policy statements dealing with air transport and authorizing the regulation of such operations, or in the licence/permit authorizing the non-scheduled flight or flights. In some cases, ad hoc decisions are made by regulatory authorities.

National policies with respect to international non-scheduled commercial operations have taken a variety of forms, ranging from severe limitation to complete freedom. Most State policies lie between these approaches. In developing policies and regulations concerning non-scheduled air services, individual States usually take into account the role of such services in the satisfaction of the demand of the public for low-price air transport; their place in the overall air transport system; and their contribution in meeting some general national priorities and interests (e.g. promotion of tourism, expansion of airport utilization, job creation and community development).

A carrier must be licensed by its home State to engage in international non-scheduled air transport. Some States require evidence of this from foreign carriers. Air transport authorities may authorize international non-scheduled operations by a national or foreign carrier by issuing a licence or permit (i.e. general authorization or permission given on a relatively long-term, continuing basis, for example, for a year or a season), or an ad hoc authorization for a flight or flights.

States may also adopt procedures to a) require advance approval of charter programmes or individual flights; or b) not require pre-flight approvals; and c) require pre-flight notification and/or post-flight reporting. Some States may continue to use the procedure of advance placement of carriers on a list of those eligible to perform charter flights.

Various States use combinations of the above and take into consideration reciprocity, the origin of the traffic, the region involved, the nationality of the carrier (national versus foreign), the type of carrier or size of aircraft, the kind of charter or other determinants. It is general practice for States to require the filing of a flight plan or some form of prior notification (usually 24 hours in advance) for air traffic control, customs, immigration and public health purposes (note that Annex 9 to the Convention on International Civil Aviation also contains provisions requiring Contracting States to minimize such procedures to facilitate non-scheduled operations).

Some States have concluded bilateral non-scheduled air services agreements or bilateral air transport agreements covering both scheduled and charter services to allow operation of non-scheduled services under mutually agreed terms. These agreements normally include provisions regarding charterworthiness rules (for example, acceptance of country of origin rules or harmonization of rules), points which may be served, fair and equal opportunity, pricing, traffic freedoms covered, designation and licensing of carriers; provisions similar to those found in other agreements covering technical subjects, such as customs exemption and consultation and arbitration.

Only a few multilateral agreements have been concluded on non-scheduled air services, all on a regional basis (such as the 1956 Multilateral Agreement on Commercial Rights of Non-scheduled Air Services in Europe between ECAC States, and the 1971 Multilateral Agreement on Commercial Rights of Non-scheduled Air Services Among the Association of South-East Asian Nations (ASEAN)). These agreements generally provided for a more liberalized regime in authorizing non-scheduled operations between the signatory States, for example, by permitting free admission of certain types of non-scheduled flights (e.g. humanitarian, emergency charters, single entity charters or charter flights serving routes not being directly served by scheduled services), subject only to prior notification.

A basic problem experienced by many States in respect of regulating international non-scheduled services is how to strike a balance between the commercial interests of the

scheduled services operators and those of the charter operators in the same markets, while taking into account the overall economic interests of the country concerned. States that maintain significant regulation generally impose various restrictions or controls to ensure that non-scheduled air services do not impair the profitability and efficiency of their scheduled air services and/or to satisfy a need for some balance in the charter benefits received by carriers of each involved State. The controls which such States may use on commercial non-scheduled operations include:

- marketing restrictions through charter definitions and rules (for example, by not permitting certain types of charters);
- geographical and route restrictions (for example, by allowing the operation of certain types of charters only to defined areas or only on specified routes);
- capacity control (involving, for example, a specific numerical limit or one related to a specific percentage of scheduled flights); and
- price control.

Another problem encountered by various States in regulating international non-scheduled services stems from the absence of an agreed clear definition of a non-scheduled service (it is defined only as other than a scheduled air service). This is especially true in situations when the distinction between the two types of air services has become blurred. For example, as charter services became more readily open to use by members of the public they came to be called “*schedulized charters*” or “*programmed charters*”, i.e. *charter flights open to the public that are so regular or frequent that they constitute a recognizable systematic series*.

Most scheduled carriers now offer reduced fares and conditions which were once more common to charter services. As the air transport industry has evolved and as more States have adopted a liberal policy towards international air transport regulation, the usefulness of making such distinctions for charters has been questioned. In the case of the European Union, the “third package” of air transport liberalization has effectively eliminated the regulatory distinction between the two (by allowing non-scheduled/charter carriers to operate scheduled flights and sell flights directly to the public), although the distinction tends to be retained by the industry in terms of how non-scheduled services are marketed and operated.

Chapter 4.7

AIRLINE COMMERCIAL ACTIVITIES

This chapter discusses the commercial and related aspects of international air transport (sometimes referred to as “doing business” matters). Although not given as much importance by regulators as the principal regulatory elements of market access, capacity and tariffs, they are of regulatory interest because of their potential for increasing or decreasing market access and the effectiveness and/or profitability of air carriers.

The first three sections of this chapter present subjects that have been regulated since the beginning of international air services, namely, currency conversion and remittance of earnings, employment of non-national personnel and the sale and marketing of international air transport.

The fourth section of this chapter presents the ever-evolving environment of airline product distribution and electronic commerce including computer reservation systems and the Internet. The fifth section discusses regulation of the growing activity of aircraft leasing.

The sale and marketing of international air transport services, airline product distribution (including computer reservation systems), and aircraft leasing are regulated to various extents largely by air transport authorities. In contrast, two other activities (currency conversion and remittance of earnings, and employment of non-national personnel) are regulated primarily by non-aviation authorities using exchange controls and immigration laws, respectively, along with regulations of general applicability. Internet activities (such as online sales via the Internet) are virtually unregulated at the time of this writing but may become topics of future governmental regulation.

CURRENCY CONVERSION AND REMITTANCE OF EARNINGS

The extensive worldwide network of travel agents and the ability to provide international air transport on an interline basis combine to permit air carriers to sell tickets in many countries in the world, including those which they do not serve directly. Thus, air carriers accumulate revenues in many currencies, some of which are subject to exchange controls. *Currency conversion and remittance*, changing local currency remaining after local expenses have been subtracted from local revenues into a convertible currency which can be transferred by the air carrier to its head office or elsewhere, have been long-standing problems in cases where States, for a variety of reasons, have imposed exchange controls which do not permit, which restrict, or which result in extensive delays in currency conversion and remittance.

In a number of instances, air carriers have, often under the auspices of the International Air Transport Association (IATA), made collective efforts to secure the conversion and remittance of their blocked earnings in certain countries. There have also been a few instances of joint representations by the governments concerned for the same purpose.

Formal regulatory efforts to ensure currency conversion and remittance have, however, tended to fall in the bilateral area. A small minority of the bilateral air services agreements registered with ICAO contain provisions according designated airlines the right to convert and remit any excess of local receipts over local disbursements. In this regard, ICAO developed a model bilateral clause for currency conversion for use by States in their bilateral air services agreements. (The text of the model clause can be found in Doc 9587.)

In almost all cases where conversion and remittance of local currency are dealt with bilaterally, there is some type of limitation, such as subjecting the process to an agreed formula or special payment regime, limiting the transfer to the air carrier's head office, or specifying the convertible currency. In some cases the provisions require that the conversion be prompt or at a particular rate of exchange (e.g. the rate of exchange in effect on the date of conversion, the rate for current transactions, or the official rate) and that remittance be without tax or other limitation.

A more general condition (whether stated or not) which can in some instances unduly lengthen the conversion and remittance process is that the conversion and remittance be in accordance with the procedures established in the State's exchange control regime. In many cases, this will result in the civil aviation authorities having to convince officials of another government department and/or a private entity, such as a bank, of the importance of complying with the bilateral commitment to convert and remit.

EMPLOYMENT OF NON-NATIONAL PERSONNEL

International air carriers, by the nature of their business, employ personnel of different nationalities. With respect to some activities, they prefer to employ *non-national personnel*, persons who do not have the nationality of the State in which they are to work (and who usually have the nationality of that State in which the air carrier has its headquarters). Consequently, such personnel require authorization from that State to reside and work therein. Depending on the laws and regulations of the State concerning residence and employment and how they are applied, these personnel may be able to qualify for admittance for residence and employment with the air carrier. Where this is not the case, however, States have sought other means to ensure that their air carriers could employ non-national personnel in some categories of activities.

A small minority of the bilateral air services agreements registered with ICAO contain provisions allowing a foreign air carrier to bring in and maintain in a State certain types of non-national employees. Almost all of these provisions contain some type of restriction, such as:

- a reciprocal numerical limit;
- a requirement that a certain percentage of the foreign air carrier's local employees be nationals;

- a requirement that employees be located at airports/cities served directly by the air carrier; and
- a requirement that their entry and stay be governed by national law or mutual agreement between air carriers.

The principal difficulty in this area lies in the requirement (explicit or implicit) that the admittance for residence and work of the non-national employee of the air carrier be subject to national law and regulations. In some cases, national law and regulations either make no provision for non-national employees of air carriers or impose requirements that the non-national employee cannot meet. Consequently, a few of the bilateral provisions on employment of non-national personnel are stated in fairly broad, unrestricted terms; for example, work permits will not be required.

Another aspect of the situation concerning non-national personnel is that, as in the case of conversion and remittance, civil aviation authorities find themselves in the position of having to convince officials of another government department (in this case, immigration authorities) of the importance of complying with a bilateral commitment to allow the entry and residence of certain non-national personnel employed by foreign air carriers. In this regard, ICAO also developed a bilateral model clause on non-national personnel and access to local services for use by States, which can be found in Doc 9587.

SALE AND MARKETING OF INTERNATIONAL AIR TRANSPORT

The ability to sell and market international air transport is an important element of an air carrier's operations. Although there are provisions on the sale of air transport services in over one-third of the bilateral air services agreements registered with ICAO, *marketing*, the promotion of sales by such means as advertising and incentives, can be subject to several different regimes, depending on the activity.

Almost all of the provisions in bilateral air services agreements concerning the sale of international air transport include the right of a foreign air carrier to maintain sales offices and to sell its products directly or through agents. Some of these provisions specify the right to sell in certain currencies and require that users be free to purchase the air services of the carriers concerned.

Among the restrictions found in sales provisions are a requirement for airline agreement on all commercial matters and a requirement allowing sales offices only *online*, i.e. at airports/cities directly served by the foreign air carrier (though in some other cases, a foreign designated airline may be allowed to set up sales offices *off-line*, i.e. at cities not within the system of scheduled services of that airline). ICAO developed a bilateral model clause on the sale and marketing of air service products which is provided in Doc 9587.

Although the term “marketing of international air transport” is not found in bilateral air services agreements, some States consider that the term “freely sell its services” or that the right to a fair and equal opportunity to compete with air carriers of the other party necessarily includes marketing activities. The term does appear in the Annex on Air Transport Services of the General Agreement on Trade in Services (GATS — see Chapter 3.3). In the Annex, the marketing of air transport services includes “all aspects of marketing such as market research, advertising and distribution”. The Annex states, however, that the activities of selling and marketing do not include “the pricing of air transport nor the applicable conditions”.

Depending on the type of marketing activity involved, States have relied on one or more of the following types of regulation:

- for incentives (such as frequent flyer programmes), some States use the applicable tariff regime, including such incentives in the definition of tariff;
- for advertising, some States use national laws designed to ensure fair trading and consumer protection; and
- in general, most States use the bilateral provision according air carriers a fair and equal opportunity to compete or to operate air services covered by the agreement.

**AIRLINE PRODUCT DISTRIBUTION
AND ELECTRONIC COMMERCE**

Airline product distribution generally refers to the ways and means by which air transport services are marketed and sold, such as the traditional sales outlets of airlines and travel agents, and the more modern means of computer reservation systems and the Internet.

Airline product distribution had traditionally its principal locus in airlines’ own sales outlets and travel agents, but has gained a very effective and valuable tool with the advent of *computer reservation systems (CRSs)*, which provide information on air carrier schedules, space availability and tariffs, and through which reservations on air transport services can be made.

Computer reservation systems provide travel agents, on whom airlines rely heavily in conducting their sales, with up-to-date information not only on airlines’ flight schedules, fares and seat availability but also on a range of other travel and leisure services. CRSs also facilitate their work in making reservations and issuing tickets. In large markets, many air carriers regard participation in one or more computer reservation systems as essential.

Soon after their introduction, however, CRSs attracted considerable regulatory attention because of their increasing influence on the sale and distribution of international air transport services. A number of States were concerned that as a powerful marketing tool, CRSs could have the potential to be abused to unfairly favour certain air carriers or air services because most CRSs were then owned by major airlines. During the introduction and early development of CRSs, regulatory activity centred around four general areas:

- display of information (the sequence in which flights are displayed, how different types of flights (online, codeshared) should be treated);
- participation of air carriers (including conditions, charges, inclusion of schedules of non-participating air carriers and participation by dominant air carriers in certain markets);
- data questions (releasing information on individual bookings, safeguarding the privacy of personal data, releasing aggregated data); and
- the inclusion (or exclusion) of non-scheduled flights.

Regulation of CRSs has occurred at both national and international levels. At the national level, several States (such as the United States and Canada) have developed detailed CRS regulations. At the regional level, there also exist a few codes of conduct on CRSs, including the ones adopted by the European Community (EC), the European Civil Aviation Conference (ECAC) and the Arab Civil Aviation Commission (ACAC).

At a general, worldwide level, ICAO has developed a Code of Conduct for the Regulation and Operation of

Computer Reservation Systems for States to follow (adopted by the Council in 1991 and revised in 1996), and two alternative model clauses on CRSs for optional use by States in their air services agreements (contained in Doc 9587). As noted in Chapter 3.3, the GATS also includes, in its Air Transport Annex, computer reservation systems as one of the three air transport services to be liberalized under the multilateral trade rules.

Specific aspects of CRS regulation tend to reflect different approaches based on whether such regulation should be general or more detailed. For example, the ICAO Code requires a neutral display or displays of air carrier schedules, space availability and tariffs. To achieve this, the regional European codes prescribe detailed requirements for flight displays, differentiating among non-stop flights, other direct flights and connecting services; while the national regulations of the United States do not prescribe detailed requirements but require the same flight display criteria to be used for all participating air carriers.

For bilateral regulation, States have generally relied on the provision in their bilateral agreements that accords their air carriers a “fair and equal opportunity to compete/operate” and on reciprocity to deal with CRS issues involving international air transport. Some recent bilateral agreements have also included specific provisions on CRSs designed to protect air transport users and to ensure non-discrimination and fair competition amongst CRS service providers and participants.

Since the mid-1990s, the world’s CRS industry has consolidated into four major global CRS vendors — Amadeus, Galileo, Sabre, and Worldspan. With the expansion of their presence and scope of business, these global vendors have increasingly seen themselves as *global distribution systems (GDSs)*, i.e. providers of comprehensive travel information and reservation capability not only on airlines but also on hotels, car rentals, rails and leisure tours.

Another significant development is the change in the ownership structure of the CRSs. There has been a steady overall decline in airline ownership of all the major CRSs, and by the end of 2003, three of the four global CRS vendors (except Amadeus) had become totally non-airline owned.

At the same time, along with the advancement of technology and the general growth of *electronic commerce (e-commerce)*, i.e. commercial activity conducted through electronic means, there has been a rapid increase in online sales of airline products via the Internet.

There are broadly two types of e-commerce activity in airline product distribution:

- a) *business-to-consumer (B2C)*, which allows a business entity to sell products or provide services to end-user consumers via the Internet (e.g. with access to airline flight schedules, seat availability and fares, as well as to permit bookings and other activities). There exist several different types of B2C websites. They are: 1) traditional travel agents’ websites which constitute a simple extension to retail outlets and business processes; 2) online travel agents who do not have conventional retail outlets; 3) airlines’ own websites; and 4) websites jointly owned by groups of airlines which offer wider product choices than the ones offered by a single airline’s website; and
- b) *business-to-business (B2B)*, which allows the exchange of products, services, and information between business entities (e.g. airlines, travel agents, CRS vendors and suppliers of air transport) directly via the Internet. One example is an e-marketplace for airframes, engines and avionics components, maintenance services, and fuel, etc. Such B2B websites connect buyer airlines with suppliers through the Internet with the objective of creating cost savings by integrating and streamlining the supply chains. Another example is a CRS business. CRSs serve as a booking engine behind most B2C websites and as an online travel booking system for major corporations and airlines.

Major CRS vendors are also further expanding their B2B activity to the area of *business-to-business-to-consumer (B2B2C)*, in which a business entity sells a service or product to end-user consumers by using other companies as intermediaries. For example, CRS vendors provide participating travel agents with a customized web-booking facility so that CRS vendors can reach consumers indirectly via their travel agents.

These changes have created new challenges for regulators. Although a number of the original regulatory concerns with CRSs have diminished as ownership has moved away from air carriers, some other concerns have emerged from the rapid development of e-commerce, especially the Internet. Since no websites are completely independent of CRSs, regulatory attention has tended to focus mostly on the consumer and competition aspects of the Internet, similar to those for CRSs before the codes or regulations were introduced.

With respect to the consumer aspects, the issue is how to ensure that Internet-based systems provide consumers with comprehensive and non-deceptive information. While the traditional CRSs are required to provide a comprehensive source of neutral information on air services, this is not necessarily the case with websites on the Internet, though such websites can provide consumers with additional choices of travel options with a greater variety of new products such as Internet-only fares and auction fares. One other consumer concern is the use and disclosure of personal information on the Internet. To protect consumers from incomplete and misleading information and improve consumer confidence, several States have addressed the issue under the umbrella of airline passenger rights; other States have applied general consumer protection laws/rules to the Internet transactions.

The primary issue regarding competition is whether certain practices associated with the use of the Internet are likely to undermine competition and consumer benefits, despite a competitive impetus carried to the marketplace by the Internet. On the one hand, the use of the Internet may provide greater opportunities for more vigorous competition and for new businesses, which could result in new products and services and more dynamic technological innovation. On the other hand, some areas of the Internet business may give rise to anti-competitive behaviour, where market incumbents seek to sustain or enhance their market power at least for a certain period. For example, B2B and B2C websites jointly owned by horizontal competitors holding dominant positions in the relevant markets may have the potential to use these sites to collaborate and coordinate their prices and services indirectly by signalling, or directly, thereby stifling competition. Also the owner airlines may discriminate against competing airlines, travel agents and service providers by refusing access to their Internet-based systems on fair and reasonable terms. In this regard, some States are examining the issue under the existing CRS rules/regulations, competition laws and consumer protection laws.

Regulatory response to product distribution is not easy for regulators because of the ever-changing marketplace and business practices. In addition, multiple parallel distribution channels currently coexist, and the pace and extent of acceptance of the new Internet-based systems vary amongst States, making it difficult to find appropriate regulatory formulas, or keep regulations current. Because of the changes in the CRS industry, some States (e.g. Australia, the United States), after a long review process, have decided to cease their regulation of CRSs.

Another important development is **electronic ticketing (e-ticketing)**, i.e. a method for documenting and distributing airline tickets without producing paper coupons. In an era of increased competition, electronic ticketing offers considerable cost savings for airlines and travel agents and provides convenience for consumers. Although the use of electronic tickets has in the early stage been applied mostly to single-carrier online itineraries, **interline electronic ticketing (e-interlining)**, which permits the use of electronic tickets on more than one airline, has gained increased popularity as more airlines introduced the practice or expanded the capability for additional routes. This practice may, however, have some potential regulatory implications, for example in the liability and security aspects of international air transport.

AIRCRAFT LEASING

The practice of **aircraft leasing**, i.e. the rental, rather than purchase, of aircraft by an air carrier from another air carrier or a non-airline entity, has been growing steadily in the last two decades. The use of leased aircraft plays a significant role for airlines in the provision of international air services, reflecting in particular the economics and flexibility of leasing over purchasing (such as reducing initial cost burden or debt level, gaining tax benefits, and meeting seasonal demands for additional capacity). In a liberalized regulatory environment, leasing of aircraft facilitates the entry of new carriers into the market.

There are various types of aircraft leases. They can be characterized by their purpose. A **financial or capital lease** is used by air carriers to avoid the otherwise substantial capital outlays/debt required in purchasing aircraft directly from the manufacturer, or to reduce taxation or other costs. For example, an air carrier may sell all or part of its fleet to a bank or other financial institution and then lease the aircraft back. Financial leases are long-term arrangements which give the outward appearance of ownership, e.g. the aircraft bears the air carrier's name/logo and is usually registered in the air carrier's State.

In contrast, an **operating lease** is designed to meet an air carrier's immediate need for additional aircraft, often on a seasonal or short-term basis. An air carrier with excess or under-utilized aircraft can lease them to other air carriers.

For regulatory purposes, there are two basic types of aircraft leases, namely, a **dry lease** where the aircraft is

leased without crew; and a **wet lease** where the aircraft is leased with crew. A wet lease with partial crew (such as cockpit crew or cabin crew) is sometimes referred to as a **damp lease**.

In this connection, the term **lessor** means the party from which the aircraft is leased; the term **lessee** means the party to which the aircraft is leased. For example, if air carrier A leases an aircraft to air carrier B, air carrier A is the lessor air carrier and air carrier B is the lessee air carrier.

The increasing use of leased aircraft in international air transport can, however, raise potential safety and economic issues in a situation where the leased aircraft is registered in a State other than that of the operator using it in international commercial services. Current policies and practices of States concerning the use of leased aircraft are mainly designed with a view to ensuring compliance with safety standards and that the economic rights accorded in bilateral or regional agreements are not used by third parties not entitled to them.

With regard to the safety aspects of aircraft leasing, several definitions contained in Annex 6 to the Chicago Convention are of particular interest. These are: **State of Registry**, the State on whose registry the aircraft is entered; **State of the Operator**, the State in which the operator's principal place of business is located or, if there is no such place of business, the operator's permanent residence; **operator**, a person, organization or enterprise engaged in or offering to engage in an aircraft operation; and **air operator certificate (AOC)**, a certificate authorizing an operator to carry out specified commercial air transport operations.

The fundamental safety question is which State, the State of the aircraft's registry, or the State of the aircraft's operator, is responsible for compliance with the applicable safety standards of the Chicago Convention and its Annexes, and which operator is responsible for compliance with the safety standards in applicable national laws and regulations. In some situations the safety responsibilities of the State and the operator are clear. Potential safety problems arise where a leased aircraft is registered in a State other than that of the operator using it for international air services.

States have addressed safety concerns arising from aircraft leasing using the established procedures in the Chicago Convention and its Annexes and, more recently, through Article 83 *bis* of the Convention. The Convention assigns the task of ensuring compliance with applicable safety standards primarily to the State of Registry of the

aircraft but also, for certain aspects, to the State of the Operator. Article 83 *bis* of the Convention, which entered into force on 20 June 1997 (see Doc 9587), sets out a means of transferring all or part of the duties and functions pertaining to Articles 12, 30, 31 and 32(a) of the Convention from the State of the Registry (the lessor air carrier) to the State of the Operator (the lessee air carrier).

Additionally, regulatory concerns about safety are increasingly being dealt with in bilateral air transport agreements, in regulations or resolutions of regional bodies (e.g. the European Union, the European Civil Aviation Conference) and in various ICAO meetings and studies. ICAO has also developed guidance on aircraft leasing, including model clauses on aircraft leasing for optional use by States in bilateral or regional contexts (see Doc 9587), and on the implementation of Article 83 *bis* (see Cir 295).

National regulations can have an impact on the use of leased aircraft in international air transport. For example, for safety reasons, the United States does not approve the wet lease to its national air carriers of aircraft registered in another State. However, given the widespread use of leased aircraft in international air transport, States appear to approach the approval/disapproval of leased aircraft primarily on the basis of their use by foreign air carriers and more often on a case-by-case basis than on the basis of broad, general policies.

Since aircraft leasing can be arranged in many ways, which can result in varied and complex safety situations, there is a need for coordinated and cooperative action by the different States concerned to ensure that safety responsibilities are clearly understood and met. In this regard, no single predetermined formula will fit all situations from the perspective of safety.

In the economic regulation of aircraft leasing, States either approve or do not regulate leases where the lessor is not an air carrier or controlled by an air carrier. In other words, financial and long-term operating leases where the lessor is a leasing company, bank or other entity are generally permitted in international air transport.

From a bilateral perspective, economic concerns regarding aircraft leasing tend to focus on any potential, in a bilateral air transport market, that an airline of a third country could, via a leasing situation, exercise or benefit from traffic rights to which it is not entitled. States generally permit aircraft leases between airlines of the two parties, while restricting or not allowing leases, particularly wet leases, from airlines of third countries. However, the

increase in the number of liberalized bilateral agreements, such as “open skies agreements”, which grant unrestricted traffic rights would decrease the number of situations in which a third country airline does not have the underlying route rights. In other words, a State will have more opportunities to use leased aircraft when the countries involved all have liberalized air services agreements.

From an economic perspective, dry leases do not appear to raise the level of regulatory concern that wet leases generate. To the extent that dry leases, which involve non-airline parties as lessors, are specifically mentioned in bilateral air services agreements, it is to state that such leases do not require approval but only notification to the bilateral partner. However, some bilaterals do not make any distinction between wet or dry leases and apply the same criteria to both types.

At the regional level, only the ECAC recommendation on leasing touches this area in a general fashion, stating that the use of wet-leased aircraft should not be used as a means of circumventing applicable laws, regulations or international agreements.

The use of leased aircraft to meet sudden, unforeseen needs for short periods of time, such as the mechanical failure of an aircraft awaiting boarding/loading, are dealt with at the national level, generally either through waiver or some form of prior approval. Given the extremely short notice in such situations, which makes prior approval impractical in most cases, one possible solution (as suggested by the ECAC recommendation on leasing) is to establish, based on submissions by airlines, a list of air carriers approved by national aeronautical authorities from which an air carrier may lease an aircraft at short notice, for a short period, to meet an unforeseen need.

To assist States in formulating clear, effective and transparent policies on aircraft leasing in international air transport, ICAO has developed the following checklist of factors to be considered in reaching decisions to approve or disapprove the use of leased aircraft:

- a) In every leasing situation, determine:

- 1) which States are responsible for which aspects of safety oversight;
 - 2) which operator is responsible for complying with the safety standards established by the Chicago Convention and its Annexes;
 - 3) what measures are necessary for the safe operation of the leased aircraft (e.g. crew familiarization/licence validation, etc.);
 - 4) if an agreement under Article 83 *bis* would be effective and appropriate. If so, decide:
 - i) which States will be involved;
 - ii) which safety functions will be transferred; and
 - iii) which aircraft will be included.
- b) Establish the types of leases that can be approved or need not be regulated, such as:
 - 1) financial and operating leases of non-airline entities;
 - 2) leases of aircraft owned by air carriers of parties to the relevant bilateral agreement; and
 - 3) wet leases in short-term, unforeseen situations, using a list of potential lessor airlines as approved sources.
 - c) Establish criteria for the approval of wet leases of aircraft from airlines of third countries, such as:
 - 1) possession of traffic rights involved;
 - 2) reciprocity; and
 - 3) no benefit related to the traffic carried or use of the route.

Chapter 4.8

AIRLINE COOPERATIVE ACTIVITIES

As the operating environment of the airline industry becomes increasingly competitive, international air carriers are adopting various strategies in order to adapt to the changes, including innovative cooperative arrangements. This chapter discusses three of the most notable and growing airline cooperative practices which have attracted regulatory attention in recent times, namely, airline alliances, codesharing and franchising. Because of their potential implications for market access, competition and consumer interests, they are not only dealt with by air transport regulatory authorities, but may also or alternatively be regulated, in some instances, by government entities with responsibility for competition or consumer protection.

AIRLINE ALLIANCES

Airline alliances, i.e. voluntary unions of airlines held together by various commercial cooperative arrangements are a relatively recent and rapidly evolving global phenomenon in the airline industry.

An alliance agreement may contain a variety of elements such as codesharing, blocked space, cooperation in marketing, pricing, inventory control and frequent flyer programmes, coordination in scheduling, sharing of offices and airport facilities, joint ventures and franchising.

Airline alliances, especially transnational ones, are a consequence of air carrier response to, *inter alia*, perceived regulatory constraints (for example, bilateral restrictions on market access, ownership and control), a need to reduce their costs through economies of scope and scale, and a more globalized and increasingly competitive environment. They are perceived by many airlines as an effective tool to maximize revenue and traffic feed.

Modern alliances differ from traditional airline cooperation (such as pooling) in that the latter usually involves an inter-airline agreement on tariffs and/or sharing of capacity, cost and revenue, which usually covers duopoly routes and provides little incentive for competition or efficiency; whereas modern alliances are normally built around possible synergies and complementary route structures and services.

Alliances may be domestic, regional, intercontinental or global and can be of any size, for any particular purpose or objective, or for any length of time. While numerous agreements concern cooperation on a limited scale (for example, codesharing on certain routes), the number of wide-ranging strategic alliances has been on the rise in recent years. Most notable was the emergence of several competing *mega-alliances*, i.e. alliance groupings of geographically spread large and medium airlines with extensive combined global networks. Three typical examples of such global alliance groupings are:

- **Star Alliance**, founded in 1997 by Air Canada, Lufthansa, Scandinavian Airlines System (SAS), Thai Airways International and United Airlines. (By the end of 2003, it had fifteen member airlines. Website: www.star-alliance.com);
- **Oneworld**, founded in 1998 by American Airlines, British Airways, Cathay Pacific and Qantas. (By the end of 2003, it had eight member airlines. Website: www.oneworldalliance.com); and
- **SkyTeam**, founded in 2000 by AeroMexico, Air France, Delta Air Lines and Korean Air. (By the end of 2003, it had six member airlines. Website: www.skyteam.com).

The partnership of each alliance group, however, can be unstable. An example is the alliance group dubbed “Wings” led by KLM and Northwest Airlines which formed one of

the earliest strategic alliances in 1989. This alliance has since seen many partnership changes in its members, the latest being that its founding member, KLM, entered into a merger agreement in October 2003 with Air France, a founding member of SkyTeam.

While most alliance arrangements centred around passenger-related services, some alliances have been formed with a focus on air cargo business. Intermodal alliances with railways have also grown in Europe and North America. Furthermore, cross-alliance partnerships, usually bilateral, have also entered the already complex scene.

The impact of global alliances on the airline industry is significant. The marketing power of global alliances, together with their competitive consequences, including their dominance at some hubs, has small and medium-sized airlines concerned about their survival which has prompted these airlines to either develop a particular segment of a market or to compete as low-cost point-to-point airlines. Some small airlines also moved to form regional alliances with neighbouring like-minded carriers (for example, Carib Sky Alliance), and to enter into franchise agreements with major airlines (see discussion under airline franchising).

Alliances have also attracted considerable attention from regulatory authorities because of their potential impact on market access, competition and consumer interests. Some proposed major alliances have been examined closely by relevant national and regional regulatory bodies; and, in some cases, certain regulatory measures were introduced to ameliorate the anti-competitive aspects of the arrangements (e.g. requiring the surrender of a certain number of slots to facilitate other airlines' entry into the market). Regulatory treatment of airline alliances varies amongst States and is mostly on an ad hoc rather than systematic basis, often dictated by general aero-political considerations of the States concerned.

AIRLINE CODESHARING

Closely related to the subject of alliances is the practice of codesharing, which developed earlier than the growth of alliances and has been a major element of most alliances.

The practice of codesharing, by which one carrier permits a second carrier to use its airline designator code on a flight, or by which two carriers share the same airline code on a flight, can take different forms. It may, for

example, involve a major carrier sharing its code with a smaller feeder carrier; it may also be an arrangement between two or in some instances three or more international carriers for an international flight operated in cooperation, or for a connecting service that uses the same code.

Like other forms of airline cooperative ventures, code-sharing has been adopted by many international carriers to adapt to the increasingly competitive environment. From the carriers' perspective, the main reasons for codesharing are the following:

- to achieve a better display position in computer reservation systems in cases where the flight is treated as an online service with a higher priority in listing than an interline service;
- in the context of an increasingly competitive environment, to form some kind of cooperative links with other carriers to maintain, protect and improve their positions in the market;
- to achieve better presence on routes they do not fly, by means of an inexpensive marketing tool;
- to enable two carriers to operate a viable joint service where traffic volumes do not justify individual operations by the two carriers;
- to obtain feeder traffic;
- to remain competitive or in some cases to enhance competitive position by drawing traffic within the orbit of codesharing partners; and
- to obtain increased market access to points hitherto restricted by capacity provisions in bilateral air services agreements.

In practice, the effects on airlines differ depending on their specific situation. In some cases, airlines that are parties to a broader alliance can clearly benefit from codesharing when the practice brings in additional traffic and extra revenue. In other cases, within the context of a transnational alliance, the codesharing arrangement may benefit only other carriers and other countries if the services are exclusively operated by the other party, with possible consequences for the first party in terms of employment and revenue.

For airports and passengers alike, codesharing per se will not automatically be beneficial in every situation;

although when circumstances are favourable, it can be of value to airport operators and the travelling public (e.g. where it results in more frequent flights to/from the airport, and more choices for passengers).

Airline codesharing may have advantages for developing countries in so far as it can offer the possibility of serving very thin routes at minimal cost and using heretofore unused rights. It can thus be an instrument to facilitate the participation of airlines of developing countries in international air transport. However, the practice has yet to take hold. This may change as the potential benefits of this form of cooperation come to be viewed as a means of adapting to the changing competitive environment and of enabling airlines of developing countries to participate more economically and effectively in international air transport.

As with alliances, codesharing has given rise to a number of regulatory concerns since it is perceived as a means of indirectly increasing market access. It is now the general practice that international codesharing is dealt with in the bilateral negotiating process and that underlying traffic rights are required in order for any codeshared services to be approved. In some cases, specific provisions in bilateral agreements may also be required for codeshared services, especially when a third country is involved. Other than its link to underlying traffic rights, codesharing is not subjected to systematic regulatory treatment, but rather ad hoc treatment dictated by general aero-political, economic or competition considerations.

Codesharing affects competition in two ways, either enhancing it through the provision of additional or better services or reducing it through a concentration of forces playing in the market. Therefore, the potential pro- or anti-competitive aspects of a proposed codesharing operation need to be weighed carefully on a case-by-case basis.

Codesharing may give rise to uncertainties concerning carrier liability. Two important legal issues are posed by codesharing: which air carrier is liable under the Warsaw regime and which air carrier is responsible to the passenger in user-/consumer-related matters? In the case of the former it would appear that codesharing, when it involves a connection, need not necessarily be equated to successive carriage, such as is the usual case with interlining, but that ultimate legal responsibility could nonetheless be determined by the contract of carriage between the passenger and the contracting carrier, depending on the interest of the passenger or its claimants. Where the codeshared service does not involve successive carriage, then other legal considerations concerning the right of liability redress may

arise. With respect to responsibility regarding user-related issues, the usual airline industry rules and practices apply, i.e. responsibility rests with the operating carrier. In any event, before providing services, codesharing partners should agree on liability issues and give notice to the public so that these become part of the terms and conditions of carriage.

The consequences of codesharing for the consumer raises the question of whether it is a deceptive practice or, alternatively, whether it is beneficial to the consumer. The overall concern is that information on actual or potential travel given to the travelling public must be accurate and complete and not confusing or in any way misleading. In this regard, ICAO recommends that information provided to consumers should include flights, operators, intermediate stops and changes of aircraft, airlines and airports. Although airlines have the main responsibility for taking action, others in the information chain such as travel agents, computer reservation systems and airports should also be involved. It is further recommended that, as a minimum, passengers be provided with the necessary information in the following ways:

- orally and, if possible, in writing at the time of booking;
- in written form, on the ticket itself and/or (if not possible), on the itinerary document accompanying the ticket, or on any document replacing the ticket, such as a written confirmation, including information on whom to contact in case of problems and a clear indication of which airline is responsible in case of damage or accident; and
- orally again, by the airline ground staff at all stages of the journey.

Codesharing can have implications for some other aspects of air transport regulation. For example, the practice has some governments concerned about the safety standards of foreign airlines with which their national airlines have codesharing arrangements. Another concern relates to the security implications of the potential transfer of a security threat, which may exist against one airline and be spread to its partner or partners in a codesharing arrangement, and any subsequent additional security measures imposed by the appropriate authorities. It is therefore essential that clear lines of accountability and responsibility be established for the parties involved in a codesharing arrangement since technical and operational regulations may vary considerably from one airline partner to another.

More detailed information and analysis of codesharing can be found in Circular 269 — *Implications of Airline Codesharing*.

AIRLINE FRANCHISING

Airline franchising is a commercial arrangement that involves a franchiser carrier granting a franchise or right to use various of its corporate identity elements (such as its flight designator code, livery and marketing symbols) to a franchisee carrier to market or deliver the latter's air service products, typically subject to standards and controls intended to maintain the quality desired by the franchiser.

Under a franchising arrangement, the franchisee (usually a small airline) typically pays a fee and royalties to use the brand of the franchiser (usually a major air carrier) and other services associated with that brand (e.g. uniforms and other marketing symbols, computer reservation systems and frequent flyer programmes, sales and marketing, customer service procedures, etc.), with the intent that passengers will feel as though they are flying with the major airline. Although the franchisee assumes the public face of the franchiser, it usually maintains its independence in running its operations and carrying out its revenue management and, in some cases, may continue to use its own name for its services.

The practice of airline franchising began in the United States in the early 1980s. It usually involves a major carrier with smaller regional airlines, with the latter acting as feeders and operating under the former's brand (e.g. Air Wisconsin Airlines, Atlantic Coast Airlines as United Express; Comair, SkyWest Airlines as Delta Connection; and Mesa Airlines, Air Midwest as US Airways Express, etc.). In Europe, franchising was first experimented with in the United Kingdom, led by British Airways and, more recently, has been used by several other major European carriers such as Air France, Lufthansa and Iberia, and has now been extended by these airlines to Africa and the Middle East (e.g. British Airways franchise agreements include three African carriers: Comair of South Africa, Regional Air of Kenya and Zambian Air Services of Zambia).

It should be noted, however, that there is a distinction between the kind of franchise operation that has existed in the United States for many years and the more recent franchising arrangements developed by the European carriers.

For example, there is often a financial connection between the United States franchiser carrier and its feeder airlines (typically with the major carrier having equity investment in the latter). This is not the case in Europe. Also, in the United States there is normally a close operational connection between the partner airlines, with the major carrier having a greater measure of control and influence over the feeder airlines, and the arrangement often involving closer coordination in terms of marketing, equipment interchanges, ground handling and so on. In Europe, these elements do not exist to the same extent, and traffic feed is not the primary objective of the arrangement as it is in the United States. Therefore, in terms of the method of franchising, the European arrangements adhere more to the franchising concept described above.

While franchising is currently not widely practised (except in North America and Europe), it is becoming increasingly common as air transport liberalization continues to spread.

The major advantage of franchising is that it allows partner carriers to marry their respective strengths, i.e. a small airline can combine its low-cost operations with a major airline's strong brand and powerful distribution system while the major carrier can extend its brand to routes without actually operating air services on such routes.

From a franchiser's respective, benefits may include:

- more brand exposure, and traffic feed from the franchisee carrier;
- increased income from fees and royalties;
- extension of its network, with minimum financial risk, to thinner regional routes that it could not serve profitably or to markets where it was absent; and
- better utilization of slots at congested airports for more lucrative routes (when it transfers thinner routes to its franchisees).

As for the franchisee carrier, benefits may include:

- more brand recognition, and traffic feed from the major carrier;
- access to the major carrier's product distribution systems and frequent flyer programme (FFP);

- access to skills and training; and
- enhancement of services and reputation.

However, there can also be certain risks associated with franchising. For example, the franchiser may risk damage to its brand image if things go wrong with the franchisee's service (such as an accident, poor quality service). Where the franchiser airline depends on its franchisee to serve certain markets, it may risk a hole in its network if the franchisee terminates the partnership. As for the franchisee carrier, such an arrangement may lead to potential loss of identity and increased cost or pressure to maintain standards set by the franchiser.

Since franchising, by way of branding/marketing, essentially allows an airline to assume the public face of another, it may raise many issues similar to those of codesharing which also involves more than one airline. For example, in terms of technical and operational aspects, there can be questions regarding attribution of rights and responsibilities of the parties concerning the services operated under such an arrangement (e.g. Whose call sign should be used for air traffic purposes? Under whose route, traffic and operational rights should the services be operated? Whose slots should be used for the services? Who should be responsible for filing schedules, tariffs?).

From an economic regulatory perspective, issues can arise in three main areas: a) market access rights; b) effects on competition; and c) need for consumer protection.

Franchising is unlikely to create major regulatory problems when it involves only carriers of the same country (such as those in the United States) or of the same common market (e.g. the European Union) because the services involved are mostly domestic and are subject to the same regulatory regime (especially in a fully liberalized environment). However, when franchising involves international services, particularly carriers of different countries, it has been known to cause certain regulatory problems or even disputes.

In the area of market access rights, for example, a problem may arise when the franchisee airline operates a service on routes where it has its own underlying route/traffic rights, but it flies its aircraft and holds out its service using the franchiser's brand (which does not have the underlying route/traffic rights on those same routes). Some States (e.g. South Africa) are more flexible in allowing their local carriers to operate services using a foreign franchiser's name on both domestic and international routes. Some other States may, however, require that both the franchiser and the franchisee possess the necessary rights under relevant bilateral agreements. Questions may also arise regarding designation. Can a franchisee use the designation of franchiser? If yes, how can a foreign franchisee meet the franchiser country's designation criteria on ownership and control? Or, can the franchisee operate under its own designation but hold out its services using the franchiser's brand?

With regard to the effects on competition, although many of the routes operated by franchisees tend to be too small to support multi-carrier competition, it might still be questioned, under certain circumstances, if relevant competition law requirements are being met because of the nature of such arrangement, which involves a high degree of cooperation between two independent airlines, especially when a major franchiser carrier coordinates schedules and pricing with its franchisee partner airlines on routes covering major markets.

In the area of consumer protection, since franchising, like codesharing, involves an operator using the brand and/or code of another airline, it may have similar deceptive effects on passengers (e.g. passengers may find themselves booked with one carrier but flying with another). Therefore, there is a regulatory need to address the disclosure issue. In this regard, many of the regulatory measures for code-sharing may also be applied to franchising. Regulatory concerns about clear lines of responsibility between the partners for safety, security, liability, and economical issues (e.g. denied boarding compensation, mishandled baggage, etc.) should also be properly addressed.

Chapter 4.9

AIR PASSENGERS

The enormous growth of international air travel, coupled with multiple innovations in services and tariffs, particularly in liberalized markets, has created several new areas of concern to air transport regulators. One of these areas relates to consumer interests which has received increasing attention and covers many issues including “air passenger rights” and the contractual relationship between air carriers and their users.

The first section of this chapter discusses the positive development in recognized passenger rights and related issues. The next two sections present topics that represent somewhat negative or troublesome developments from the standpoints of both passengers and air carriers, namely, unruly or disruptive passengers and improperly documented passengers.

PASSENGER RIGHTS

Although there is no formal, internationally agreed definition, the term *passenger rights* has been used to generally refer to the entitlements of passengers to protection from or compensation for certain actions by airlines and/or airports that are adverse to their interests, which are specified in government regulations or in the airline’s contract of carriage and/or other published commitments. Some such rights have been protected for many years. One example is the Warsaw Convention (see also Chapter 3.2) which governs the liability of air carriers in the case of accidents, loss of baggage, and delays.

Along with the continuing liberalization of international air transport regulation, the protection and improvement of passenger rights has achieved greater importance, particularly, but not exclusively, in major markets. For airlines of developing States operating to and from major markets, the treatment of this matter has longer term consequences for their competitive viability.

Despite the emphasis liberalization places on opening up markets to meet user needs, the focus by airlines on cost pressures and competitive market forces has sometimes had an adverse impact on consumer interests. The quality of service offered by airlines has not always met consumers’ expectations. Infrastructure limitations at some airports (such as airspace congestion, and passenger handling capacity) have also compounded the situation. These have often led to passenger dissatisfaction with the service conduct of airlines and/or airports such as inadequate handling in the case of flight delays and cancellations, and insufficient information for users.

In response to a perceived decline in customer services, a significant number of States, in recent years, have adopted regulatory measures that address some of the issues such as denied boarding compensation, bans on smoking, on-time performance statistics and access for disabled passengers. Some governments have also required airlines, *inter alia*, to ensure that all tariffs are made available to the public, to disclose information on cancellation policies and to avoid misleading advertisements.

At the industry level, many airlines have also taken the initiative by making *voluntary commitments* (*i.e. non-legally binding self-regulation*) to clarify or improve their policies or practices with regard to certain customer services (such as fare offers, ticket refunds, denied boarding, flight delays and cancellations, baggage handling, response to complaints, and special passenger needs), often in response to public pressure and to avoid regulatory measures.

On a worldwide basis, the International Air Transport Association (IATA) has developed conditions of contract (Resolution 724), which lay down the contractual conditions applicable to the international flights of its member airlines as a binding resolution. IATA has also developed conditions of carriage (Recommended Practice 1724), aimed at the harmonization of the general conditions under which passengers travel on inter-carrier journeys. Unlike Resolution 724, this Recommended Practice, which focuses

on “best practice”, does not bind member airlines, nor does it apply to domestic flights or to services operated by non-member carriers. In addition, IATA produced a Global Customer Services Framework in June 2000 as guidance for its member airlines in developing their own voluntary commitments.

From a regulatory policy perspective, the improvement of the quality of passenger service may be achieved by different approaches including competitive response, regulatory measures and/or voluntary commitments. But each approach may raise certain issues and concerns.

States that consider air transport primarily a commercial activity governed by market forces tend to rely on competition and, at least initially, voluntary air carrier measures supplemented as necessary with regulatory measures.

Advocates of this approach believe that competition in the marketplace is the best way to meet consumers’ expectations, especially in the areas relating to “value for money”, such as seat configuration, in-flight services, meals and e-commerce services. On the basis of their own commercial judgement of the market demands, airlines provide various combinations of service quality and prices. Consumers benefit from the availability of different product options, and if a carrier does not meet their expectations, they can switch to competing airlines. Consumers’ comparison shopping should, in general, enhance service competition so that the marketplace itself generates better performance.

Nevertheless, there exist some instances where competition does not necessarily guarantee a minimum level of service that customers can expect, either directly or indirectly, and below which no carriers should fall. This is particularly true when consumers cannot make an informed choice of airlines in planning their travel arrangements due to the lack of information available to them. Certain elements (for example, the treatment of disabled and special-needs passengers) might not even be a matter of competition between airlines. Also consumers’ negotiating position is relatively weak because they have to accept contractual conditions and business practices decided by airlines and fully pay for the service before actually taking the flight.

Recognizing the limits of competitive response, some States have introduced certain regulatory measures to strengthen passenger rights, create contractual certainty and make more information clearly and readily available to consumers on a wide range of subjects. These range from airline business practices (such as codesharing, availability of fares, and ticket refunds), contracts (such as conditions

of carriage, denied boarding, liability provisions, misplaced baggage, and special passenger needs) to operational performance disclosure (such as on-time performance and complaints).

However, a major complication with government intervention generally in consumer interest matters is that regulatory measures which tightly define the quality of service may remove a key competitive element, thereby limiting the scope of the service areas where competition might be the best means of improvement. Regulations often impose additional costs on airlines, thereby affecting airlines’ competitiveness, pricing and product differentiation. Furthermore, regulations, once introduced, may be difficult to withdraw or amend promptly according to a change of situation, and the attempt to regulate one element can result in a proliferation of regulations involving other elements. Authorities may also incur administrative costs for regulation.

To avoid the potential problems associated with the regulatory approach, States may choose to rely initially on voluntary commitments by airlines (and service providers if applicable), which are regarded as complementary to the regulatory approach. The airline industry also favours the voluntary commitment approach by outlining service targets or “best practices” that individual airlines agree to build upon according to the type of services they offer. If voluntary commitments are prevailing and attainable, and the monitoring system is well established, then regulatory measures on subjects covered by the commitments would generally be unnecessary.

In practice, different levels of interest in and response to consumer issues have resulted in the emergence of regimes in various States or regions with similar aims and objectives on passenger rights but with differing regulatory, self-regulatory and contractual requirements. A potential consequence of this patchwork of emerging regimes for international air transport is that carriers with broader networks, especially ones involving major markets, could face numerous and sometimes conflicting regulatory and contractual requirements, creating confusion for airlines and consumers alike.

A fragmented system of consumer interest regulatory regimes may also make it costlier for airlines to apply consistent internal training and to maintain adequate communication, and may affect common or compatible industry systems and standards as well as the multilateral interline system. Therefore, uniformity of standard terms for conditions of contract/carriage, together with international

liability regimes and required ticket notices, would greatly assist in the smooth functioning of interline carriage.

Another consequence, if the regulatory approach is increasingly applied vis-à-vis voluntary commitments, is that there is a potential risk of extraterritorial application of national (or regional) laws by a State (or a group of States). Although existing regulatory measures are applied internationally on the country-of-origin basis, a State may wish to apply them irrespective of the origin or destination of the flights operated by its national carriers, or to further extend the scope of application to foreign carriers that pursue their commercial activities in its territory, especially where it considers that foreign carriers could avoid its jurisdiction. An example of such a case would be a State applying its denied boarding regulation to all flights to and from its territory, including those operated by carriers of third countries.

It is also possible that a State may wish to regulate a contract of carriage irrespective of where the contract was concluded because e-commerce makes it difficult for a State (and the courts) to determine the exact place where a contract was concluded. However, since the application of national laws with such broad scope would impose obligations on foreign carriers or affect contracts established in the territories of third countries, it would create potential legal uncertainty and raise objections by some States concerned.

ICAO has done considerable work in this field, including the development of guidance material in such areas as conditions of carriage, fare guarantee, baggage, tariff disclosure, denied boarding and codesharing. The ICAO Code of Conduct for the Regulation and Operation of Computer Reservation Systems also covers the consumer protection aspects in the context of CRSs. This guidance can be found in *Policy and Guidance Material on the Economic Regulation of International Air Transport* (Doc 9587).

Guidance material for air transport users has also been prepared to assist States in publishing or encouraging the publication of booklets intended to inform air passengers and shippers of their rights and obligations (see Appendix 5 to this manual). Furthermore, Annex 9 to the Chicago Convention sets out standards and recommended practices for passenger facilitation designed to allow air transport users to proceed through airports with minimal delay and difficulty.

The issues identified above were also addressed by the fifth ICAO Worldwide Air Transport Conference (ATConf/5), held in March 2003, which drew the following conclusions in respect of possible action by States:

- a) As a premise in addressing consumer interest issues, States need to carefully examine what elements of consumer interest in service quality have adequately been dealt with by the current commercial practices of airlines (and service providers if applicable) and what elements need to be handled by the regulatory and/or voluntary commitment approaches.

In this regard, the following indicative list, together with airlines' conditions of contract/carriage (see summary in the box following this section), could serve as a checklist of many of the consumer interest subjects a State may wish to monitor:

- 1) the availability of lower fares including fares on websites;
 - 2) reservation, ticketing and refund rules;
 - 3) advertisements;
 - 4) airline's commercial and operational conditions;
 - 5) check-in procedures;
 - 6) handling of and compensation for flight delays, cancellation and denied boarding;
 - 7) baggage handling and liability;
 - 8) operational performance disclosure such as on-time performance and complaints; and
 - 9) assistance for disabled and special-needs passengers (i.e. people with reduced mobility).
- b) States need to strike the right balance between voluntary commitments and regulatory measures, whenever government intervention is considered necessary to improve service quality. States should rely generally and initially on voluntary commitments by airlines (and service providers), and when voluntary commitments are not sufficient, States should consider regulatory measures.
 - c) In implementing new regulatory measures, States should minimize the unnecessary differences in the content and application of regulations. Efforts to minimize differences would prevent potential legal uncertainty that could arise from the extra-territorial application of national laws, without diminishing the scope for competition or hampering the operating standards and procedures for interlining.

AIRLINE'S CONDITIONS OF CONTRACT/CARRIAGE

As described in Chapter 4.3 — Air Carrier Tariffs, “conditions of carriage” means the terms and conditions established by an air carrier in respect of its carriage, which are referred to as “conditions of contract” when shown on the passenger ticket or air waybill. The various benefits and limitations set out in the conditions of carriage/contract, along with the price for the services being provided, constitute a “contract for carriage” between the air carrier and the user.

In order to harmonize the conditions under which passengers travel on inter-carrier journeys, the International Air Transport Association (IATA) has developed Resolution 724 on *Passenger Ticket — Notices and Conditions of Contract* which are binding on its member airlines for application to international flights. The Notices cover limitations of liability, overbooking, information on taxes and user fees, and some national requirements. IATA has also developed Recommended Practice 1724 on *General Conditions of Carriage (Passenger and Baggage)* which is for optional use by its members. This Recommended Practice (2000 version) consists of the following elements:

1. What Particular Expressions Mean in These Conditions
2. Applicability
general; charter operations; codeshares; overriding law; conditions prevail over regulations
3. Tickets
general provisions; period of validity; coupon sequence and use; name and address of carrier
4. Fares, Taxes, Fees and Charges
fares; taxes, fees and charges; currency
5. Reservations
reservation requirements; ticketing time limits; personal data; seating; reconfirmation of reservations;
cancellation of onward reservations
6. Check-in and Boarding
7. Refusal and Limitation of Carriage
right to refuse carriage; special assistance
8. Baggage
free baggage allowance; excess baggage; items unacceptable as baggage; right to refuse carriage;
right of search; checked baggage; unchecked baggage; collection and delivery of checked baggage;
animals
9. Schedules, Delays, Cancellation of Flights
schedules; cancellation, re-routing, delays, etc.
10. Refunds
involuntary refunds; voluntary refunds; refund on lost ticket; right to refuse refund; currency;
by whom ticket refundable
11. Conduct Aboard Aircraft
general; electronic devices
12. Arrangements for Additional Services
13. Administrative Formalities
general; travel documents; refusal of entry; passenger responsible for fines, detention costs, etc.;
customs inspection; security inspection
14. Successive Carriers
15. Liability for Damage
16. Time Limitation on Claims and Actions
notice of claims; limitation of actions
17. Other Conditions
18. Interpretation

**UNRULY OR DISRUPTIVE
PASSENGERS**

The term *unruly or disruptive passengers* refers to passengers who fail to respect the rules of conduct on board aircraft or to follow the instructions of crew members and thereby disturb the good order and discipline on board aircraft.

In recent years, there has been an increase in the reported incidents involving such passengers. The incidents involved various types of offences and reprehensible acts, including assault on crew members or passengers; fights among intoxicated passengers; child molestation, sexual harassment and assault; illegal consumption of drugs on board; refusal to stop smoking or consuming alcohol; ransacking and sometimes vandalizing of airline seats and cabin interior; unauthorized use of electronic devices; destruction of safety equipment on board; and other disorderly or riotous conduct. These incidents are not restricted to a particular airline, country, customer, class of service, or length or type of flight. Such acts and offences can sometimes directly threaten the safety of the aircraft. There were cases where the aircraft commander had to make an unscheduled stopover to disembark the unruly passenger(s) for safety reasons. These incidents have caused growing international concern.

The increase of these incidents also presents new challenges for both governments and air carriers, particularly when such acts occur on board international flights. Authorities and airlines are often faced with legal and regulatory issues in handling unruly passengers due to the existence of certain gaps in their relevant national laws and existing international aviation security conventions.

One major issue concerns what constitutes an offence that is subject to prosecution. The movement of aircraft across national borders means that they will be subject to the laws and regulations of different jurisdictions. Due to the diversity of laws and regulations, an act or omission which is regarded as an offence in one jurisdiction may not be so regarded in another jurisdiction.

When suspected offenders are to be prosecuted in a State where a foreign aircraft has landed, the question may arise whether their acts or omissions constitute offences not only in the State of landing but also in the State of Registry of the aircraft and in the State where the acts or omissions

occurred. Therefore, it is necessary to establish a uniform list of offences that would be regarded as a common denominator for all States involved. Such a list will be instrumental in incorporating the relevant offences into States' respective national laws or regulations allowing prosecution and application of sanctions.

Another major issue concerns jurisdiction. There are many cases in which unruly passengers have to be released without being submitted to judicial proceedings due to the lack of jurisdiction of the State where the aircraft lands. Under most domestic laws, States other than the State of Registry of the aircraft normally do not have jurisdiction over offences committed on board the aircraft outside their respective territory, except for certain offences covered by international treaties or international customary law, such as hijacking, sabotage and hostage taking.

Under international law, while international conventions relating to aviation security have proven to be an effective tool in combating hijacking, sabotage and similar forms of unlawful interference against civil aircraft, these conventions are not specifically designed to deal with other, less serious types of offences committed by unruly passengers. For example, under the *Convention on Offences and Certain Other Acts Committed on Board Aircraft* (Doc 8364), signed at Tokyo on 14 September 1963, offenders cannot be held in restraint beyond the first stopover; by the time the aircraft has returned to the State of Registry, the offenders, as well as the witnesses, will be long gone. Many offenders have taken advantage of this situation to avoid prosecution.

To address these issues, ICAO has done considerable work, focusing on three major areas, namely, a list of specific offences for inclusion in national law, the extension of jurisdiction over such offences, and the appropriate mechanisms for addressing these offences. Drawing on States' experience, it has developed some guidance for States which mainly addresses the legal aspects of unruly passengers.

To address the issue of what constitutes an offence, a list of offences has been drawn up by ICAO in order to provide a common denominator for offences as a basis for national prosecution.

With respect to the jurisdiction issue, some States have, in their respective domestic legislation, extended their jurisdiction to cover offences committed on board foreign aircraft that next land in their respective territories. Based on

this emerging practice, ICAO prepared a model jurisdictional clause extending national jurisdiction over such offences for possible use by States in their relevant national law to fill the jurisdictional gap referred to above.

The list of offences and the jurisdictional clause which are part of a proposed model legislation developed by ICAO can be found in Circular 288 — *Guidance Material on the Legal Aspects of Unruly/Disruptive Passengers*.

Among the legal and regulatory measures that States could take to address the problem of unruly passengers are the adoption of national laws, bilateral arrangements, and the interpretation and application of existing international conventions. In addition, other practical or preventive measures could also be taken or considered on the part of airlines and other involved parties. For example, airlines could develop or update policies and programmes specifically designed to address the problem of unruly passengers. Some key areas to be covered in this regard include:

- *Passenger management and operating procedures.* This involves the process of dealing with airline passengers and may include measures and procedures to prevent or deal with incidents, such as denied boarding procedures, passenger information policies, smoking and alcohol policies, and conflict-resolution training for cabin crew and passenger-handling staff.
- *Improvement of the air travel environment and experience.* This involves identifying factors which may cause passenger stress and aggression, such as overbooking, delayed flights and lack of information for passengers.
- *Increased passenger awareness.* Passengers should be made aware that unruly acts on board aircraft are against the law and may result in convictions or being denied boarding in the future. The policy may need to be specified in the terms and conditions of carriage. Campaign material such as posters and airline ticket inserts may be utilized for this purpose as well.

In this respect, efforts have been made both within and outside ICAO to develop guidelines and other material containing preventive measures concerning unruly passengers, in particular, the ICAO aviation security training package material (ASTP 123/Airline), as well as relevant airline programmes and other relevant documentation.

**IMPROPERLY DOCUMENTED
PASSENGERS**

Another negative development associated with air passengers is the problem of *improperly documented passengers who attempt to migrate from one State to another under false pretences contrary to the national laws of either State*. Since the mid-1980s, such attempted migration, whether for political, economic or social reasons, has become a worldwide phenomenon, placing extensive economic burdens both on governments and air carriers.

In recent years the problem has been compounded by the involvement of criminal elements in the organization of such illegal movements and the adoption by would-be migrants of various methods of evading or prolonging the immigration process in their chosen destination State. Such methods include the use of fraudulent travel documents (or the fraudulent use of valid documents by imposters), the destruction of travel documents during the flight or voyage, and *mala fide* applications for asylum upon arrival at the intended destination.

The use of improper travel documentation as a tactic for gaining access to air transportation to a desired destination adversely affects the general security of States, regardless of whether their territories may be a source of, a transit point for, or a recipient of this type of traffic.

Traditionally States have relied upon legislative provisions making transport operators responsible for ensuring that their passengers are adequately documented for travel, and imposing fines or penalties as deterrents to the international carriage of inadmissible persons. Many international airlines, in cooperation with States, have been obliged to implement intensive programmes to detect fraudulent documents and to identify and intercept passengers who are travelling with the intent to migrate without proper documentation.

However, the increasing volume of illegal traffic and the sophistication of methods employed have called for more effective measures and concerted efforts at the international level to counter travel document fraud and address issues related to *inadmissible persons, i.e. persons refused admission to a State by its authorities*.

In this connection, the principal concern of the civil aviation community is the use of improper travel documents

contrary to Article 13 (Entry and clearance regulations) of the Chicago Convention rather than the traveller's status as "admissible" or "inadmissible", which is an immigration issue.

Another problem that has caused some concern is the lack of cooperation and communication between States sending and receiving inadmissible persons. For example, there have been cases where passengers were shuttled back and forth between States because of disagreements about their "inadmissible" or "deportee" status. Aircraft were detained on the ground for days, and even weeks, because of disputes between administrations on their respective responsibilities with regard to inadmissible persons.

These border control problems consume an inordinate amount of the civil aviation community's service resources, including control authorities at airports. Reactive measures are often time-consuming which degrade the clearance service for the general travelling public. Moreover, inadmissible persons being repatriated against their will have been known to pose problems for the security of the flight.

ICAO is leading the international efforts to address these problems and issues. It has developed relevant Standards and Recommended Practices (SARPs) in Annex 9 (*Facilitation*) to the Chicago Convention, and accompanying guidance material. The SARPs of Chapter 3 of the Annex set out general procedures to be followed by States and airlines when dealing with inadmissible passengers. The objective of the SARPs and guidance material is to: encourage better cooperation and communication between industry and government, and among States affected; help States enhance their border controls through, *inter alia*, preventive measures (including, for example, better use of modern technology such as machine readable travel documents) and improved immigration procedures; and clearly define the responsibility of the State and the operator involved in the handling, including repatriation, of inadmissible persons. Annex 9 also requires States to remove from circulation fraudulent, falsified and counterfeit documents.

Details of the SARPs and guidance material can be found in Annex 9 and Parts 1, 2 and 3 of Doc 9303 — *Machine Readable Travel Documents*.

Chapter 4.10

AIRPORT-RELATED MATTERS

This chapter presents three airport-related matters that have attracted increasing regulatory interest in recent times. Discussed in the first section is ground handling at international airports, which has historically been subject to regulation at the national, bilateral and even multilateral levels. The second section examines the topic of allocation of flight arrival and departure slots at international airports, an issue faced by an increasing number of States where demand outstrips supply as a result of the substantial growth in air transport. The third section discusses airport privatization.

GROUND HANDLING

Although there is no formal, official definition, *ground handling* is generally understood to broadly include services necessary for an aircraft's arrival at, and departure from, an airport but to exclude those provided by air traffic control. The *Airport Economics Manual* (Doc 9562) separates the ground-handling function into terminal handling (passenger check-in, baggage and freight handling) and ramp handling (aircraft handling, cleaning and servicing). Ground handling generally excludes maintenance and repair of aircraft, although in some instances so-called line maintenance may be considered as a part of ground-handling services.

Services related to ground handling may be provided at an airport by one or more airlines, by one or more concessionaires, by the airport itself, or by a combination of any of these means.

States usually regulate ground handling as an airport activity, either as operators of airports (directly or via autonomous agencies) or by relying on national laws and regulations concerning such matters as non-discriminatory treatment. This regulatory activity will take into account provisions on ground handling contained in bilateral air

services agreements and, where applicable, measures of regional multilateral regulatory authorities, such as the European Commission.

ICAO guidance on ground handling includes, for example, Recommended Practice 6.6 in Annex 9 (*Facilitation*) to the Convention on International Civil Aviation. That provision recommends that air carriers, in agreement with and subject to reasonable limitations which may be imposed by the airport authorities, be offered several choices with respect to ground-handling arrangements, including providing their own services. In cases where airports provide such services or derive concession revenues from their provision, appropriate guidance is contained in *ICAO's Policy on Charges for Airports and Air Navigation Services* (Doc 9082) with supplementary guidance being provided in the *Airport Economics Manual* (Doc 9562).

In terms of bilateral regulation, a small minority of the bilateral air services agreements registered with ICAO contain provisions concerning ground handling. These provisions tend to fall into two general categories. The first and larger category is composed of provisions which stipulate that ground-handling services are to be provided reciprocally by the respective designated airlines of the two States or by a national agency approved by the State in which the ground-handling services are provided. The provisions in the second category recognize the right of a designated airline to perform its own ground-handling operations or to use other airlines or service providers but this right is often subject to conditions established by the State in which the ground-handling services are performed.

Along with the trend of liberalization in international air transport, many States, in recent years, have introduced liberal ground-handling provisions in their bilateral air services agreements, and ground handling is now frequently outsourced to specialized companies. Unlike air carriers, ground-handling companies are not constrained by national ownership restrictions, and they have been undergoing a process of globalization and consolidation. This has given

rise to some concern that the outsourcing of ground handling will have an adverse impact on safety, on the premise that private companies without previous experience of a safety culture are becoming involved. To address this concern, ICAO conducted, in 2001, a study on the safety aspects of ground handling, which led to a review of, and amendments to, the existing Standards and Recommended Practices (SARPs) in Annex 6 to the Chicago Convention, and other ICAO guidance material. These amendments were designed to ensure that States give adequate consideration to the safety aspects of ground-handling arrangements in the certification and surveillance of aircraft and airport operators and ground-handling companies. In addition, ICAO also developed an amendment to the existing ICAO model clause on ground handling to take account of the requirement for compliance with applicable safety and security provisions (see Doc 9587).

SLOT ALLOCATION

*An **airport slot** is a specific designated day and time (usually within a 15- or 30-minute period) for an aircraft to arrive at or depart from an airport.*

Slots are important to air carriers not only for operational reasons (e.g. for aircraft, crew, and gate use scheduling) but also for commercial reasons (e.g. matching departure and arrival times to time periods believed to be preferred by most travellers provides a more attractive service). The availability of slots at an airport can be limited due to various physical constraints such as the capacity limitations of the runway(s), terminal(s), boarding gates and air traffic control facilities. Therefore, in situations where an airport becomes congested and the demand for slots exceeds available supply, some type of rationing or **slot allocation mechanism**, i.e. a formula for the allocation of slots among their users, will be required.

The allocation of slots is typically carried out among the airlines serving the same airport and involves consultation with the airport authorities. Since a slot change at one airport may have major implications for a flight in terms of securing corresponding slots at other airports, it is often necessary to have wider coordination.

The mechanism most often used by airlines for schedule coordination and slot allocation has been the IATA Airline Schedule Coordination Conferences, which are held twice yearly, about four months prior to each **scheduling season** (one runs from April to October, the other from

November to March). Participation is open to any airline (IATA member or non-IATA member). An important element in this system is so-called “**historical precedence**” or “**grandfather rights**”, i.e. rights to retain what was held before, in this case slots used in the previous equivalent season. Schedule changes and/or adjustments including those required by new flights or services are accommodated mainly through voluntary adjustments or exchanges of slots between the airlines concerned. The worldwide membership of the Conference gives it a unique ability to accommodate the necessary adjustments in flight schedules at all affected airports, as long as sufficient slots are available. However, a system based on “grandfather rights” can, in the view of some observers, result in new entrant airlines and new services not being accommodated at particularly congested airports.

States generally endorse the use of the IATA mechanism in schedule coordination and slot allocation. However, in some States where the problem of insufficient airport capacity is more serious, regulatory authorities have found it necessary to introduce certain additional measures to limit or ration access to congested airports. In some cases, airlines not presently serving the congested airport are not allowed to begin service, and certain types of operations (such as non-scheduled flights or all-cargo services) are either not permitted or severely limited. In some cases, international services with rights granted under a bilateral air services agreement are given priority for slots over domestic flights. Limitations at some congested airports are sometimes mitigated where slots are available at other airports serving the same city. In some severe cases, government-to-government negotiation and/or agreement is required for resolution of specific slot allocation problems. In some States, internationally agreed slot allocation rules are applied (e.g. the European Union member States follow the EU common rules for the allocation of slots at Community airports, which essentially use the IATA mechanism within certain constraints; for example, new entrant airlines are given priority in the allocation of 50 per cent of the slots that become available).

Over the last two decades, the increase in commercial air services has continued to outstrip available capacity at more and more airports, chiefly in Europe but in other regions as well. States, airports and airlines have sought to deal with this problem through measures that focus on either increasing the capacity (supply-side approach) or managing the lack thereof (demand-side approach).

Among the supply-side actions which can overcome or reduce a shortage of airport slots are: a) building new

airports or expanding existing ones; b) improving air traffic control capabilities through new technology and procedures; and c) increasing efforts and resources in passenger and cargo facilitation.

Among the regulatory policies and practices States have used aimed at the demand-side of the problem are:

- setting annual limits on the number of aircraft movements or passengers;
- negotiating new or expanded traffic rights only when these can be accommodated at the airport(s) concerned;
- negotiating access to slots bilaterally in advance;
- applying a policy of reciprocity;
- developing and encouraging the use of alternate airports;
- recognizing the link between noise rules and demand; and
- employing peak period pricing in landing charges to help spread the demand for slots to periods when the airport's capacity is not fully utilized.

Some States, where airport capacity constraints have been particularly severe, have used one or more measures from both the supply-side and demand-side approaches.

Clearly, increasing airport capacity through new or expanded airports, runways and terminals has the greatest impact on resolving a scarcity of slots. However, these types of improvements usually take years to put in place and, in some cases, the additional capacity is quickly used up by traffic growth. Moreover, it is also equally clear that for some airports environmental and physical constraints make substantial expansion of the existing facilities impractical or prohibitively expensive. Nevertheless, even at these airports incremental capacity increases are possible.

Improvements in facilitation and air traffic control services can be employed to use the existing airport infrastructure more efficiently. These can provide important incremental increases in the number of aircraft, passengers and cargo which can use a capacity-constrained airport, and these merit continuous evaluation by airlines, airports, and customs and immigration authorities. Improvements in air traffic control involving coordination with many States can

take time and patience but will ultimately provide benefits in terms of increased use of both en-route and airport capacity.

With regard to regulatory measures on slot allocation, since the situation at each congested airport tends to be particular to that facility, States have dealt with the situation in a number of different ways. One approach is to allow air carriers to preserve the so-called “grandfather rights” but provide slots for new entrants and new services by, for example, reserving a fixed proportion of new capacity for them. Another approach is a “use or lose” rule, which requires that an air carrier use its assigned slots at a specified level (e.g. 80 per cent of the annual or seasonal total) or lose them. A third approach is to allow air carriers to exchange slots on a one-for-one basis to use the available slots more effectively.

Other potential devices include buying and selling of slots, auctioning, and some combination or variation of the above methods. Although some such practices exist (e.g. the United States permits the purchase, sale and lease of certain domestic slots at some airports subject to the Federal Aviation Administration's High Density Rule), whether they can be applied to international air services remains to be addressed. For example, there has been concern over the commercial trading of slots because of possible effects on competition, and unresolved legal issues.

There has been a continuing debate as to the “ownership” of airport slots, primarily in terms of claims by airlines which have historically used them for long periods of time. However, some formal regulatory regimes either explicitly or implicitly exclude this concept, for example, stating that airlines do not acquire property rights to the slots assigned to them and that the slots must be returned to the aeronautical authority under certain circumstances. The implicit approach ties the continued use of the slot to its use at a specified level (the “use or lose” rule) and allows the exchange of slots on a one-for-one basis.

Some issues related to capacity-constrained airports will involve broader regulatory policy questions, such as the enhancement of competition, the avoidance of excessive concentration and abuse of dominant positions, as well as the compatibility of broad market access with capacity-constrained airports. Although the broad granting of traffic rights bilaterally and regionally with multiple airline designation creates additional potential demand for airport slots, it also provides some relief in the form of flexibility to use alternate airports and cities which can accommodate new and increased air services.

A number of States will nevertheless have the task, in the long term as well as the short term, of balancing conflicting objectives in terms of which international air services will be able to use their capacity-constrained airports. In fashioning responses to this problem, States will have to take into account the legal framework provided by the Chicago Convention (e.g. Article 15 which establishes a national treatment principle in the context of the use of airports and other air navigation facilities), air services agreements, regional and national slot allocation rules and existing voluntary mechanisms for managing insufficient airport capacity. However, the response will have to fit the situation of the individual airport(s) concerned and will therefore vary depending on the nature of the constraint and the means taken to overcome it.

Additional information on this subject can be found in Circular 283 entitled *Regulatory Implications of the Allocation of Flight Departure and Arrival Slots at International Airports*.

PRIVATIZATION OF AIRPORTS

Until the late 1970s, the great majority of international airports were owned and managed by governments. Many changes have since occurred in ownership and management structure of airports, generally in the direction of reducing direct government involvement. Private sector involvement in this area began in the 1980s, gaining momentum in the 1990s, especially in Asia, Europe and Latin America, but slowing down in recent years.

The changes have generally been thought of as “privatization”. However, these changes can take various forms and, while they generally reflect a move away from government ownership and management, they do not necessarily (and indeed rarely) denote outright privatization per se, particularly as regards ownership.

In the context of airports, *privatization* connotes either full ownership or majority ownership of facilities and services by the private sector, while *private participation* or *private involvement* refers to situations in which the private sector plays a role in the ownership or management, or both, of the airport (e.g. in the form of a management contract, a lease or minority equity) but the majority ownership remains with the government.

Corporatization refers to the undertaking of creating a legal entity (a corporation or company) outside the govern-

ment to manage and operate the airport, either through a specific statute or under an existing general statute such as company law. Normally, the ownership of the corporation remains with the government. However, private sector participation in a corporatized body is possible.

Commercialization refers to a management approach which applies business principles or places special emphasis on the development of commercial activities. Commercialization should not be equated to private participation or privatization because the former connotes an approach to management while the latter refers to change in the ownership or control of management.

Autonomy refers to the powers of the managers of airports to utilize revenues generated and take independent managerial decisions on issues falling within the charter of the organization. An **autonomous airport authority** is an independent entity established to operate and manage one or more airports and empowered to use the revenues it generates to cover its costs. An autonomous airport authority can be a unit within the government, a corporate authority or a company wholly owned by the government.

Privatization and private participation in the provision of airport services has been part of the general process of globalization and liberalization of the economies of the world and the movement toward privatization of commercially oriented industries and services managed by States or State-owned entities. A number of other factors, such as financial problems faced by States in airport development, the need to reduce budgetary deficits and the emergence of a global airport management industry, have motivated States to move towards privatization and private participation.

Faced with increasing difficulty in the financing of airports, many governments have come to realize that where traffic volumes are relatively high, it may be possible to pass the burden of financing airport development programmes to the private sector. Moreover, private participation and privatization in the provision of airport services has been seen as a source of revenue to cover or reduce budgetary deficits. Profit-making airports can provide a regular source of tax revenue. Financial bids for private participation and privatization of airports have further encouraged States to move in this direction.

The current approach of governments is to move away from the ownership and management of non-core public utilities, and airports, at least the major ones, are considered as commercial entities rather than public utilities. Larger airports are turning into cities in themselves with marketplaces

and meeting points for people and business. There is the perception that privatization leads to improvement in the management of airports.

From the commercial perspective of the business and financial communities, an airport can be a sound investment. Airports are essentially monopolies. Growth in traffic is generally continuous and faster than the growth of the gross domestic product over the intermediate and longer terms. The credit ratings of airports are generally very high, and they have strong cash flows. Although airports are subject to government regulations, commercial activities at airports, which produce significant revenues, are generally less regulated or not regulated at all. Consequently, there has been a gradual emergence of a global airport management industry.

In most States, private participation and privatization in the provision of airport services has taken place in stages. For example, in the United Kingdom, major airports were initially transferred to a government corporation. Several years later they were transferred to a government-owned company. Soon thereafter, the shares of this company were sold to the private sector. In some European countries, the airports were first transferred to separate companies owned by the State, and the divestiture of shares was gradual. Evidence suggests that States have generally benefited from a gradual change in ownership and management structure.

Private participation in the provision of airport services has basically taken three forms: management contract, lease (which is sometimes called concession), and transfer of minority ownership. Apart from airports originally owned by private entities, fully privatized airports or airports with majority private ownership are few.

Because airports are monopolies upon which users are highly dependent, in almost all States in which privatization or private participation has taken place, regulatory authorities exist or have been established in some form to ensure that monopoly power is not abused, especially in the case of aeronautical charges.

For States considering privatization of their airports, it is important to bear in mind that the Chicago Convention places on each Contracting State the responsibility for the

provision of airports and air navigation services in its territory in accordance with the Standards and Recommended Practices. Articles 11 and 15 of the Convention provide for non-discrimination between Contracting States. Article 15 deals with basic charging principles. While the Convention does not prevent States from delegating functions to private entities, the responsibility for ensuring that all the provisions of the Convention are fully complied with rests with the State. In addition to the Convention, there are other international agreements, such as bilateral or regional air services agreements, which may impose obligations on a State party to such agreements with respect to some aspects of the provision of airports or air navigation services.

A change in the ownership and management structure in the provision of airport services may not necessarily solve all the problems that an airport or a group of airports may be facing. The change may be harmful in the long run if poorly planned. The objectives of any change should be clearly defined.

The primary objective of airports and air navigation services is to provide safe, secure, efficient and economical services to users. There are several ownership and management options that may be considered to achieve this end. There is no best option for global application. A State should choose an option best suited to it. Selection of an option should be done after careful consideration and planning. Regardless of the organizational form or legal status, the State remains ultimately responsible for safety and security.

In this connection, ICAO has developed guidance material which provides information and analyses of the options available for States when considering a change in ownership and management in the provision of airports and air navigation services, together with the possible implications of these options, and discusses major issues to be examined. This guidance is contained in Circular 284 — *Privatization in the Provision of Airports and Air Navigation Services*. Other related guidance in this field include *ICAO's Policies on Charges for Airports and Air Navigation Services* (Doc 9082), the *Airport Economics Manual* (Doc 9562) which also covers economic regulation of airports, and the *Manual on Air Navigation Services Economics* (Doc 9161).

Part 5

GENERAL TERMINOLOGY

Chapter 5.0

INTRODUCTION TO GENERAL TERMINOLOGY

The first four parts of the manual have presented and defined many terms, each in its particular context within the regulatory content, process and structure of the national, bilateral and multilateral regulation of international air transport. Part 5 presents general terminology which is common or supplemental to all parts of the manual.

Unlike the usual alphabetical listing of terms in a glossary, the terms in this part of the manual are presented under four distinct generic groupings: Chapter 5.1 — Air Carriers; Chapter 5.2 — Aircraft; Chapter 5.3 — Air Services; and Chapter 5.4 — Airports. Most of the terms defined or identified are routinely used in connection with the economic regulation of air transport. Some terms are frequently used in other contexts but as they fall under the generic groupings, they have also been included in this part for comprehensiveness and for additional useful information.

The terminology in these four chapters is drawn from a variety of sources and is not intended to be exhaustive (ICAO's numerous publications, primarily manuals in other disciplines, are sources where specific aviation terminology can be found). Some terms have definitions that are widely accepted, such as those developed by ICAO or those found in the Convention on International Civil Aviation. Most of the definitions or descriptions herein, however, have no formal status. Some have, nevertheless, been developed and applied by States in particular contexts, such as in bilateral regulation. Some terms have different meanings when applied in different contexts, while others are in common usage and appear frequently in the media. A few of the definitions are relative, evolving in meaning as technology advances and as applicable regulatory regimes change. In general, as air transport evolves, so does its terminology and the use of it. All of these considerations have been taken into account in the development of this part of the manual.

Chapter 5.1

AIR CARRIERS

An **air carrier** is an enterprise that engages in provision of transportation services by aircraft for remuneration or hire.

Air carriers can be identified by the type of operations they offer:

- a **scheduled air carrier** or **airline** is one that engages mainly in scheduled services (though it may also operate some non-scheduled flights). (See Part 1 of Doc 9587 and Chapter 5.3 of this manual for the definition of scheduled and non-scheduled services);
- a **non-scheduled air carrier** is one whose primary activity is non-scheduled operations;
- a **charter carrier** is a non-scheduled air carrier that operates only charter flights.

An **international carrier** is one that provides air transport services on routes involving more than one State and that may also operate domestic air services.

A **scheduled international carrier** is a carrier authorized to operate scheduled international air services, while a **non-scheduled international carrier** is one authorized to operate international non-scheduled flights.

A **domestic carrier** is one that primarily provides air transport services wholly within the territory of its home State.

Under national regulation of air transport, a **licensed carrier** (in some cases, referred to as a **certificated carrier**) is an air carrier that holds a formal authorization from a constituted authority to operate air transport services. In some States a licence is issued to a national carrier and a permit is given to a foreign applicant, while in some others, a licence is granted for scheduled services and a permit for charter flights.

A **national carrier** is an expression used to refer to an air carrier, established in accordance with the national law of a State, which is usually the only or the principal air carrier of that State in the provision of air transport services including international air services, and which is regarded as a national instrument in air transport.

A **flag carrier** is a term often used interchangeably with “national carrier” but more from an international perspective because the aircraft of such carrier usually bears the national flag of the State in the provision of international air services. Note, however, that Article 20 (Display of marks) of the Chicago Convention only requires that aircraft engaged in international air navigation bear its appropriate nationality and registration marks (States generally use letters and numerical numbers for this purpose). Therefore, there is no legal requirement under international law that the aircraft of a national carrier engaged in the operation of international air services must bear the national flag.

A **designated carrier** refers to an air carrier designed by a State under the relevant air services agreement for the operation of air services authorized under the said agreement. A designated carrier, in most cases, is the national or flag carrier of the designating State, but in some cases may also be an air carrier of another State when this is permitted under the relevant air services arrangement (e.g. in the case of a “community of interest” provision. See Chapter 4.4).

Carriers may be categorized by the type of traffic they transport. Thus:

- a **passenger air carrier** is primarily involved in the transportation of passengers by aircraft (although such aircraft may also carry freight);
- a **cargo air carrier** will primarily be involved in the transportation of freight and mail by aircraft.

Air carriers are often characterized by the role they play in national or international markets or by the scale of their operations:

Generally, a **major air carrier** provides scheduled air services on domestic trunk routes and/or on international routes, usually having a relatively large scale of operation covering an extensive route network;

- a **regional carrier** provides short-haul scheduled passenger and freight services, operating mostly turboprop and/or small jet aircraft and connecting small and medium-sized communities with major cities and hubs;
- a **feeder carrier** operates short-haul services connecting small and regional points to a hub airport, generally using small to medium-capacity aircraft;
- a **commuter carrier** operates feeder and/or regional services, more often of the point-to-point type, usually with aircraft seating no more than 30 passengers; this capacity limit, however, has been continually growing over the years and may now refer to aircraft with up to 50 seats;
- a **mega-carrier** is an expression used to refer to a very large carrier in terms of its scale of operation and/or route network. Such size may have been attained through its own growth, acquisitions of, or equity investment in, other carrier(s), or certain forms of alliance.

Some definitions concerning air carriers are based on marketing/economic considerations:

- a **niche carrier** is an air carrier specializing on particular routes or in a particular segment of the market;
- a **start-up carrier** is a newly established air carrier;
- a **new entrant carrier** means a carrier, newly established or not, that attempts to enter a market already served by other carriers;

Others are based on the characteristics of their business models:

- a **full-service carrier** is an air carrier, typically a traditional national or major carrier that operates on a relatively extensive route network (thus also

referred to as a **network carrier**) and provides a full range of services including different seating classes, in-flight entertainment, meals and beverages, on-board store, and ground facilities such as waiting lounges for premium class passengers or frequent flyer programme members;

- a **no-frills carrier** refers to an air carrier that, unlike a full-service carrier, focuses on providing low-cost air transport service to customers with simple or limited in-flight services;
- a **low-cost carrier** generally refers to an air carrier that has a relatively low-cost structure in comparison with other comparable carriers and offers low fares or rates. Such a carrier may be independent, the division or subsidiary of a major carrier or, in some instances, the ex-charter arm of an airline group.

Air carriers can also be identified by their trade membership, for example, an **IATA carrier**, i.e. a carrier that is a member of the International Air Transport Association; conversely, a **non-IATA carrier** is one that is not an IATA member.

Carriers are also qualified according to their ownership and control:

- a **state-owned carrier** is a carrier whose total or majority share of capital is held by the State (government agency, parastatal holding, etc.);
- a **private carrier** is a company whose total or majority share of capital is held by private interests;
- a **joint venture carrier** is an air carrier that is jointly owned by two or more major investing parties, which may be entities of the same or different countries;
- a **community carrier** is a term that refers to an air carrier whose substantial ownership is vested with a member State of the European Community, now known as the European Union.

In terms of airline liability, the term **common carrier** refers to a carrier that is prepared to provide transport of passengers and cargo for anyone who wishes to engage its services and is prepared to pay its charges.

Associated with air carriers are some terms commonly used in measuring airline capacity and performance and in determining their ranking in terms of traffic carried:

- **Available seat-kilometres (ASKs)** or **seat-kilometres available**, which are equal to the sum of the products obtained by multiplying the number of passenger seats available for sale on each flight stage by the stage distance (a seat kilometre is available when a seat is flown one kilometre).
- **Available tonne-kilometres (ATKs)** or **tonne-kilometres available**, which are equal to the sum of the products obtained by multiplying the number of tonnes available for the carriage of revenue load (passengers, freight and mail) on each flight stage by the stage distance (one ATK is a metric tonne of available payload space flown one kilometre).
- **Passenger tonne-kilometres performed**, which are obtained by applying a standard weight per passenger to the passenger-kilometre performed. (See also **revenue tonne-kilometre** below.)
- **Revenue passenger-kilometres (RPKs)**, i.e. the sum of the products obtained by multiplying the number of revenue passengers carried on each flight stage by the stage distance. The resultant figure is equal to the number of kilometres travelled by all revenue passengers.
- A **revenue tonne-kilometre (RTK)** is generated when a metric tonne of revenue load is carried one kilometre. Where such load includes passenger load, the number of passengers is converted into weight load, usually by multiplying this number by 90 kilograms (to include baggage). The total **tonne-kilometres performed (TKPs)** equals the sum of the products obtained by multiplying the number of passengers, freight and mail loads carried on each flight stage by the stage (one TKP is a metric tonne of revenue load carried one kilometre).
- **Revenue passenger**, a term which, for ICAO statistical purposes (cf. Doc 9703), refers to a passenger for whose transportation an air carrier receives commercial remuneration. Such passengers include, for example, those travelling: a) under publicly available promotional offers (e.g. “two-for-one”) or loyalty programmes (e.g. redemption of frequent flyer points); b) as compensation for denied boarding; c) on corporate discounts; d) on preferential fares (government, seamen, military, youth, student, etc.), but exclude: a) persons travelling free; b) persons travelling at a fare or discount available only to employees of air carriers or their agents or only for travel on the business of the carriers; c) infants who do not occupy a seat.

Chapter 5.2

AIRCRAFT

Aircraft, when used as a generic term, means any heavier-than-air flying machine. An **aeroplane** (or a **fixed-wing aircraft**) is a power-driven heavier-than-air aircraft, deriving its lift in flight chiefly from aerodynamic reactions on surfaces which remain fixed. A **helicopter** (or a **rotary-wing aircraft**) is a heavier-than-air aircraft supported in flight chiefly by the reactions of the air on one or more power-driven rotors on substantially vertical axes (cf. Doc 9569). A **STOL aircraft** (i.e. short take-off and landing aircraft) is an aircraft designed for taking off and landing on short runways. In practice, the term aircraft commonly implies “aeroplane” or “airplane” and is often used interchangeably.

The **nationality of aircraft** is the State of its Registry (see Article 17 of the Convention on International Civil Aviation).

Transport aircraft are aircraft that are designed for the purpose of transporting persons and/or cargo. **Commercial transport aircraft** are transport aircraft that are used for remuneration or hire.

State aircraft include any aircraft used for military, customs, police or other law enforcement services of a State (see Article 3 of the Convention on International Civil Aviation).

Private aircraft are any non-State aircraft used for non-commercial purposes.

In the context of economic regulation, aircraft are often categorized according to the type of traffic they are designed to carry:

- a **passenger aircraft** is an aircraft primarily designed and configured for the transport of persons and their accompanying baggage;
- an **all-cargo aircraft** or **freighter** is an aircraft configured for the carriage of freight only (although persons who accompany certain kinds of cargo, such as livestock or oil rig machinery, may also be carried);

- a **combination aircraft** (often referred to as **combi aircraft** in the airline industry) is a transport aircraft capable of carrying both passengers and cargo on the main deck, often in varied configurations.

Aircraft can be characterized by their size:

- a **wide-body aircraft** is a large transport aircraft with internal cabin width sufficient for normal passenger seating to be divided into three axial groups by two aisles (in practice this means not less than 4.72 metres (15.6 feet));
- a **narrow-body aircraft** is an aircraft having only one aisle in the cabin with passenger seating divided into two axial groups.

Although mostly used in marketing, these two terms are also used by some States in connection with capacity regulation.

- A **jumbo jet** is a popular term applied to a large wide-body aircraft such as the Boeing 747.

The term “large aircraft” can have various definitions serving specific purposes (e.g. for pricing airport landing charges or capacity regulation). A **large aircraft**, for ICAO statistical purposes, is an aircraft of 9 tonnes (approximately 20 000 lbs) maximum certificated take-off weight (MTOW) and over; and in the context of technical regulation, an aircraft having a MTOW of over 5 700 kg (approximately 12 550 lbs).

Some other aircraft terms by size include:

- a **small** or **light aircraft**, i.e. an aircraft with an MTOW less than 5 700 kg (approximately 12 550 lbs);
- an **ultra-light aircraft**, i.e. an aircraft having an MTOW not exceeding 454 kg (1 000 lbs) and not usually used for public transport purposes.

For analytical purposes (such as in fleet planning and forecasting), aircraft can be categorized according to their seating capacity:

- a **high-capacity aircraft** is one usually in the approximate capacity range of 350 to 500 seats;
- an **ultra-high-capacity transport aircraft (UHCT)** or a **very large commercial transport aircraft (VLCT)** is a type of aircraft currently under consideration by some aircraft manufacturers that is expected to have over 600 seats.

A widespread method used by air carriers to obtain equipment or increase their fleet capacity is through leasing:

- a **leased aircraft** is an aircraft used under a contractual leasing arrangement;
- a **wet-leased aircraft** includes a crew;
- a **dry-leased aircraft** does not include a crew;
- a **damp-leased aircraft** is a term used in some cases to refer to a wet-leased aircraft that includes a cockpit crew but not cabin attendants.

In this connection, the term **lessor** means the party from which the aircraft is leased and the term **lessee** is the party to which the aircraft is leased.

Aircraft are also classified by other criteria, for example, by the type of engine they use:

- a **piston-engine aircraft**, now rarely used in commercial air transport, is one powered by piston engine(s);
- a **turboprop aircraft** is an aircraft driven by turbo-propeller engine(s);
- a **turbojet aircraft** or simply **jet aircraft** is an aircraft powered by turbojet engines;
- a **turbofan aircraft** is an aircraft having turbofan engines.

Aircraft are sometimes referred to in terms of the number of their engines:

- a **twin jet** is a jet aircraft with two engines; and
- a **tri-jet** is one having three engines.

Many twin-engine commercial transport aircraft have now been authorized for long-range operations known as **ETOPS** (i.e. extended range twin-engine operations).

Aircraft may be distinguished by the speeds at which they can fly:

- a **subsonic aircraft** means an aircraft incapable of sustaining level flight at speeds exceeding a Mach number of 1 (i.e. the speed of sound);
- a **supersonic aircraft** is one capable of flying at speeds exceeding the speed of sound;
- a **hypersonic aircraft** is one able to fly at speeds exceeding a Mach number of 5;
- the term **high-speed civil transport aircraft (HSCT)** is generally used to refer to various future supersonic commercial transport aircraft under study.

Aircraft can also be defined by the distances they can fly:

- a **short-range aircraft** is an aircraft having a non-stop flying range usually not exceeding 2 224 kilometres (1 200 nautical miles) with a full payload at normal cruising conditions;
- a **medium-range aircraft** is one usually capable of flying between 2 224 to 5 556 kilometres (1 200 to 3 000 nautical miles) with a full payload at normal cruising conditions; and
- a **long-range aircraft** is an aircraft capable of exceeding 5 556 kilometres (3 000 nautical miles) with a full payload at normal cruising conditions.

Commuter aircraft and **regional aircraft** are transport aircraft used for the operation of commuter or regional air services, usually having a relatively small seating capacity (ranging from 10 to 70 seats) or payload. A **regional jet** is a jet-powered commuter aircraft or regional aircraft.

In the context of aircraft noise regulation:

- a **Chapter 2 aircraft** is one that complies with the noise certification Standards set out in Chapter 2 of Annex 16 to the Convention on International Civil Aviation; and

- a **Chapter 3 aircraft** is one that complies with the noise certification Standards set out in Chapter 3 of Annex 16 to the Convention on International Civil Aviation (which are more stringent than those in Chapter 2).

Note that the terms **Stage 2 aircraft** and **Stage 3 aircraft** are terms applied in the United States that have meanings essentially the same as those of “Chapter 2 aircraft” and “Chapter 3 aircraft”, respectively.

Chapter 5.3

AIR SERVICES

Air service, in its broadest sense, includes any service performed by aircraft for public transportation, whether on a scheduled or non-scheduled basis. For regulatory purposes, however, the term always has a specific meaning (defined in Article 96(a) of the Convention on International Civil Aviation and used in most bilateral air transport agreements between States) and refers to any scheduled air service performed by aircraft for the public transport of passengers, mail or cargo.

A commercial air service means an air service performed by aircraft for the public transport of passengers, mail or cargo for remuneration or hire.

Air services can be classified by the geographical areas they serve, for example:

- a **domestic air service**, i.e. an air service operated wholly within the territory of a State;
- an **international air service**, i.e. an air service that passes through the airspace over the territory of more than one State;
- a **regional air service**, i.e. either an air service offered on routes serving smaller cities within a region or between regions of a State; or an air service offered on secondary routes serving smaller cities in a regional area involving the territories of more than one State;
- a **cross-border service**, i.e. an international short-haul air service operating across the borders of two contiguous States.

In economic regulation, air services are often categorized according to the type of traffic carried by the air carrier:

- a **passenger air service** is an air service performed primarily for the transport of passengers;

- a **cargo air service** is an air service provided for the public transport of freight and mail;
- a **combination service** refers to one that carries both passengers and cargo on board the same aircraft.

Air services can also be distinguished by their operational features:

- a **scheduled air service** is typically an air service open to use by the general public and operated according to a published timetable or with such a regular frequency that it constitutes an easily recognizable systematic series of flights;
- conversely, any air service that is performed other than as a scheduled air service is regarded as a non-scheduled operation, including but not limited to charter operations. Note that “non-scheduled” is a public law term, while “charter” is a private law term pertaining to the contract between an air carrier and a charterer (although these two terms have come to be used interchangeably).

In international air transport regulation, air services have been regulated under different regimes depending on whether they are performed on a scheduled or non-scheduled basis (see also Chapter 4.6). As defined by the Council of ICAO (see Doc 9587, Part 1, Section B), a **scheduled international air service** is a series of flights that possesses all of the following characteristics:

- it passes through the airspace over the territory of more than one State;
- it is performed by aircraft for the transport of passengers, mail or cargo for remuneration, in such a manner that each flight is open to use by members of the public; and

- *it is operated so as to serve traffic between the same two or more points, either according to a published timetable or with flights so regular or frequent that they constitute a recognizable systematic series.*

*Any international flight performed other than as a scheduled international air service is a **non-scheduled international flight**.*

*A **trunk service** is an air service operated on routes linking major cities, usually with a large volume of traffic.*

The term **air taxi service** can have two meanings:

- *a type of on-demand air service usually performed by small capacity aircraft on short notice in a very similar way to an automobile taxi service; or*
- *in some cases, a service operated on a scheduled basis with stops made only at points where passengers and cargo are to be picked up or discharged.*

*A **shuttle air service** is a high-frequency, no reservation passenger air service operated at regular intervals, typically on a city-pair route with high traffic density. In some cases, boarding is a continuous process and an aircraft may depart before scheduled time, if full.*

*A **feeder service** is an air service offered on regional routes that feeds traffic to major domestic or international services.*

For marketing purposes, an air service is often termed as:

- *a **non-stop service**, an air service provided between two points with no intermediate stops (not even a technical stop); or*
 - *a **direct air service** (also referred to as **through service**), an air service provided between two points by a single aircraft with intermediate stops but without change in flight number.*
-

Chapter 5.4

AIRPORTS

An **airport** (or **aerodrome**, a term that is almost synonymous, though used more in a generic sense) is a defined area on land or water that is used for the arrival, departure and surface movement of aircraft (cf. Doc 9569).

Airports can be differentiated by the type of aircraft they serve:

- a **heliport** is an aerodrome or a defined area on a structure used for the landing, take-off or surface movement of helicopters;
- a **stolport** is an airport specifically designed for STOL aircraft separate from conventional airport facilities.

Airports can also be characterized by type of activity:

- a **commercial airport** is an airport used by the general public that includes facilities for processing passengers, handling cargo and servicing commercial aircraft;
- a **private airport** serves primarily small privately owned aircraft, flying clubs, etc.

An **international airport** is a designated airport of entry and departure for international air services, where formalities such as customs, immigration, public health, animal and plant quarantine and similar procedures are carried out (see Annex 9 to the Convention on International Civil Aviation). A **gateway airport** is an international airport that is the first point of arrival or last point of departure in a State for international air services.

A **domestic airport** is an airport used for domestic air services only.

A **regional airport** generally refers to an airport of a medium or small city that is mainly served by short-haul regional services.

A **congested airport** is one whose capacity for handling traffic (air or ground) is inadequate to accommodate demand. To cope with congestion problems, one State has designated certain airports as **reliever airports**, i.e. airports that divert traffic from major commercial airports; and **supplemental airports**, i.e. airports that attract general aviation away from busy airports, thus relieving congestion in particular markets.

Several terms are often used in connection with congested airports:

- **airport capacity** is the number of passengers and amount of cargo which an airport can accommodate in a given period of time; it is a combination of runway capacity and terminal capacity.
- **runway capacity** is the number of aircraft movements which aeronautical authorities determine can safely be operated, usually stated as the total number of landings and take-offs per hour, taking into account such factors as the physical characteristics of the runways and the surrounding area, altitude, the types of aircraft involved (larger aircraft may mandate greater separation) and air traffic control (approach and aerodrome control) capabilities.
- **terminal capacity** is the number of passengers and tonnes of cargo per hour which can be processed in a terminal building (sometimes referred to as **passenger throughput** or **cargo throughput**). The type of passenger or passenger mix can influence the rate of passenger throughput. International passengers who must clear customs and immigration require more time and space than domestic passengers who are not subject to these procedures. Domestic and international cargo presents a similar situation.

An **alternate airport** is an airport to which an aircraft may proceed when it becomes either impossible or

inadvisable, for technical reasons, to proceed to or to land at the airport of intended landing (cf. Doc 9569).

A **hub airport** or **hub**, when used in a general context, means any airport having numerous inbound and outbound flights and a high percentage of connecting traffic; while in the context of scheduling and marketing from a hub-operating air carrier's perspective, it denotes an airport where many of its inbound and outbound schedules are coordinated with the aim of producing the most convenient connections and/or transshipment for passengers, freight and/or mail. The same airport may serve as a hub for more than one air carrier although this is exceptional.

A **major hub** is one with a large volume of connecting traffic, usually a centrally located airport served by more than one airline with long-haul connections.

A **regional hub** is a hub that serves a region of a State or a region comprising more than one State.

An **interline hub** is a hub at which connections or transferring of traffic are chiefly made between flights of different carriers.

An **online hub** is a hub at which connections or transferring of traffic are mostly made between different flights of the same airline.

Associated closely with the online hub is the **hub-and-spoke system** (also known as **hubbing**), i.e. an operational system in which flights from numerous points (the spokes) arrive at and then depart from a common point (the hub) within a short time frame so that traffic arriving from any

given point can connect to flights departing to numerous other points. The "power" of such a system lies in its unique ability to combine traffic from numerous city-pair markets on the same aircraft, thus permitting a service to a spoke point that would not otherwise be viable or could not support the same volume and frequency of service. The hubbing system works by moving **waves** or **banks of flights** from different origins through the hub within a period of time sufficient for traffic to interconnect.

A **mini-hub** is a secondary hub set up by a carrier.

A **mega-hub** or a **super-hub** is a very large hub.

A **second country hub** is a hub set up by an air carrier in a foreign country, typically to allow it to interconnect traffic between numerous points in its home country and numerous third countries.

While most hubs are passenger hubs, other types of hubs, in terms of traffic handled, also exist including:

- a **cargo hub**, i.e. an airport where facilities are provided for easy and fast connections and transshipment of air cargo traffic;
- a **postal hub** or **mail hub**, i.e. one which serves as a transit centre for postal or mail shipments;
- an **intermodal hub** or **multi-modal hub**, i.e. a hub that enables convenient connections or transshipment of traffic from one mode of transport to another, for example, surface to air on a sea-air routing.

APPENDICES

Appendix 1

FORMATS FOR TARIFF FILINGS

In March 1985, the Council approved Recommendation FRP/8-2 of the Fares and Rates Panel which called for the development of guidelines for the format for tariff filings submitted by airlines to governments. The Secretariat, in consultation with members of the Fares and Rates Panel, produced the formats and guidance material for passenger fares which are contained in Parts I and II of this appendix. They are for optional use by States and for adaptation to particular situations.

In 1986, the Fares and Rates Panel, in Recommendation FRP/9-2, addressed the question of filing tariffs by electronic means. As approved by the Council in March 1987, this called for compatibility amongst tariff filing systems in different States and with airline industry databases, including those in computer reservation systems, along with provision of continued manual filing of tariffs by airlines where required. In 1992, the ICAO Secretariat sought information from States concerning their current tariff filing procedures and the requirements of those States wishing to use an electronic tariff filing procedure to assist in developing some common worldwide basic requirements aimed at ensuring the compatibility envisaged in Recommendation FRP/9-2. In addition to national administrations,

some regional intergovernmental aviation organizations, such as the European Civil Aviation Conference (ECAC) and the Latin American Civil Aviation Commission (LACAC), have studied methods and implications of electronic tariff filing.

One example of the minimum elements of an electronic tariff filing system, which was developed by ECAC in consultation with companies designing such systems, is included in Part III of this appendix.

Part I — Filing requirements

The following checklists of filing requirements for international scheduled passenger fares contain more information items than individual States may require. In order to ease their administrative burden and that of airlines, States may wish to select and apply from the checklists only filing requirements which relate to those aspects of fares which they actively regulate and which they consider to be fundamental for evaluation purposes.

Section 1 — Information required for all types of filings

<i>Requirement</i>	<i>Commentary for the information of States</i>
Filing reference number	To be assigned by the authority upon receipt.
Relevant previous reference number(s)	In case of revision or update of previous filing, this should be entered by the airline. States may also require airlines to provide reference numbers for related tariff filings and/or relevant previous government notices of action.
Date/time of filing	To be entered by the authority upon receipt.

<i>Requirement</i>	<i>Commentary for the information of States</i>
Name of submitting airline(s)	Depending on national legislation and subject to proof of authority, some States may accept filings by a designated agency of the airline(s).
Nature of filing	
Airline to specify:	
<ul style="list-style-type: none"> whether the filing relates to general tariff rules, particular fare level and associated conditions, currency adjustment, or add-on; 	Filing of general tariff rules is dealt with in Section 2. For other types of filing, see Section 3.
<ul style="list-style-type: none"> whether the proposal is for new or for revised tariffs; 	In the case of revisions, States may wish to limit the filing requirement to identification by the airline of changes only.
<ul style="list-style-type: none"> whether the filing flows from IATA or other multilateral airline agreement, bilateral airline agreement, or is a single carrier filing; 	In order to evaluate the robustness of an IATA or similar agreement, States may wish to require the airline(s) to specify the geographical scope of application of the agreement, i.e. whether it is a “full” or “limited” agreement, and whether it includes “escape” and/or “short-notice” amendment provisions.
<ul style="list-style-type: none"> whether approval is requested under regular statutory provisions or under exemption provisions for “short-notice” or “matching” filings. 	In the case of “matching filings”, States may wish to limit the filing requirement to identification by the airline of the tariff to be matched.
Date of introduction proposed	The date proposed by the airline on or after which travel should be at the fares, conditions or rules in the tariff filing.

Section 2 — Filing of general tariff rules

<i>Requirement</i>	<i>Commentary for the information of States</i>
Text of relevant IATA resolutions or other multilaterally agreed airline tariff rules and/or text of individual airline general tariff rules	The types of resolutions or rules specified are basic to the establishment of tariffs and have an impact on existing and proposed fares. Other general rules or conditions govern such matters as children’s, infants’ and agents’ discounts; reservation and payment conditions; ticket validity; as well as cancellation, re-routing and refunds. All such resolutions and rules would generally apply to all fares unless they are specifically overridden by the conditions attached to particular fares (see Section 3).
Airline to provide:	
<ul style="list-style-type: none"> conditions of carriage (not applicable for fares to and from Canada/United States); 	

<i>Requirement</i>	<i>Commentary for the information of States</i>
<ul style="list-style-type: none"> • conditions of service (e.g. seat pitch and seats abreast for each class of service); • baggage allowances and charges; • fare construction rules; • currency conversion rules; • agents’ commission rules; • other general tariff rules or conditions (airline to specify). 	
Period of proposed effectiveness	Dates proposed by the airline. Basic IATA rules such as those governing fare construction and currency conversion may technically cease to exist in the absence of an IATA agreement on particular fares. States may wish to require the airline to designate whether the rules on file would, nonetheless, remain effective in these circumstances or whether the airline would file replacement rules.
Availability of promotional benefits	States may wish to require airlines to notify them of all incentives offered to passengers in conjunction with international fares, such as “frequent flyer” programmes or discounts on hotel accommodations. Where such incentives are attached to a particular fare and States require them to be filed, they would form part of the fare submission (under Section 3).

Section 3 — Filing of particular fare levels and associated conditions
(including filing of currency adjustments and “add-ons”)

<i>Requirement</i>	<i>Commentary for the information of States</i>
Fare type (e.g. “normal economy”, “advance purchase excursion” — airline to identify)	Where the filing is made pursuant to a bilateral or multilateral intergovernmental agreement which incorporates a “fare band” arrangement, States may wish to require the airline to designate the “fare band” with which the proposed fare is intended to conform and to declare whether it does so. (Such a declaration could reduce or eliminate the need for most additional information.)
Fare code to be used (e.g. YLE45 — airline to identify)	States may wish to encourage clarity and consistency.
Class of service (e.g. first, intermediate or economy)	This would include notification by the airline of the provision of facilities such as sleeper seats; in such cases, any applicable surcharge should be reflected in a separately specified fare level.

<i>Requirement</i>	<i>Commentary for the information of States</i>
Trip type (e.g. one-way, round trip, circle trip, open jaw — airline to specify)	—
Date of sale proposed (where different from the proposed date of introduction)	Where States permit airlines to offer or sell proposed fares in advance of the date of introduction while the fares are still “subject to government approval”, States may wish to require airlines to specify arrangements for the provision of advice to purchasers about the potential consequences of the unapproved status of the fares, for example, possible non-applicability, possible surcharge, and rights to refund.
Date of expiry proposed	Some air services agreements specify that a tariff remains in force until replaced. However, the provisions of many agreements make specification by the airline of a proposed expiry date necessary in order to define the period of prolongation of existing tariffs in cases where replacement tariffs are disputed.
Geographical area, routes or specific city-pairs of application	See comments under “fare levels” below. Where applicable, specific routings or directions of travel should also be indicated.
Fare levels	Unlike fare conditions, which may be common to a number of city-pairs, fare levels generally differ according to city-pair and must therefore be specified separately by the airline. See the chart at the end of this section entitled “Presentation of proposed fare levels” for possible forms of presentation.
Currency adjustments	Revisions should be reflected as changes in local currency fare levels and filed as above. Depending on national legislation and/or applicable air services agreements, States may also require notification of the changes in the currency adjustment factor and/or “IATA” exchange rate concerned.
Add-ons	Add-ons (also known as proportional fares) are used in conjunction with specified fares to establish through fares to and from many additional points, and as such, they create many more fares which may fall under the jurisdiction of States in the same way as the specified fares themselves. Add-ons may be filed by the airlines at the same time as the relevant fares or separately for intended application to already approved fares and to subsequent fare filings.
Airline to specify:	
<ul style="list-style-type: none"> • points between which the add-ons apply (that is, origin, destination and construction points); • routings for which the add-ons are applicable; • fare types to which the add-ons apply; • any restrictions on combinability; • currency in which the add-ons are expressed; • proposed levels. 	

<i>Requirement</i>	<i>Commentary for the information of States</i>
<p>Rules and conditions specific to the fare concerned</p> <p>Airline to specify:</p> <ul style="list-style-type: none"> • period of application, e.g. all year or within defined periods (seasonal, time of day or week); • specific reservations, payment and ticketing conditions (e.g. those for advance payment, “instant” purchase or standby fares); • minimum stay; • maximum stay; • stopover conditions (number/places/charges); • routing conditions (including online and/or interline transfer restrictions); • restrictions on the number of seats available for sale at the fare concerned (other than constraints of class of service or aircraft capacity); • restrictions on combination with other fares; • restrictions on advertising or sales; • eligibility restrictions (e.g. in connection with preferential fares restricted to persons having specified attributes in terms of age, occupation, religion, etc.); • documentary requirements (proof of age, residence, occupation, etc.); • promotional benefits (including availability of discount hotel accommodation, “frequent flyer” arrangements, etc. (see also Section 2)); • other applicable rules or conditions (airline to identify). 	<p>The checklist includes the most common rules and conditions. States may find it helpful to prescribe or agree with airlines a standard presentation framework for the rules and conditions they require airlines to file, with standard numbering for each rule or condition. (In this regard, IATA Resolution 100, “Standard Condition Resolution for Special Fares”, lists 30 rules/conditions applicable to all such fares unless the resolution concerning a particular fare specifies otherwise.) Airlines should specify details against any such rule or condition that applies to the fare in question.</p>
<p>Additional rules and conditions specific to group fares</p>	<p>States may wish to require airlines to specify details against any rule or condition that applies to the fare in question.</p>

<i>Requirement</i>	<i>Commentary for the information of States</i>
<p>Airline to specify, where applicable:</p> <ul style="list-style-type: none"> • minimum group size; • group requirements (e.g. affinity, incentive group) and method of formation; • requirements for travel together (outbound and return); • permissible changes from initial composition of group; • other applicable rules or conditions (airline to specify). 	
<p>Additional rules and conditions specific to inclusive tour fares</p>	<p>States may wish to require airlines to specify details against any rule or condition that applies to the fare in question.</p>
<p>Airline to specify, where applicable:</p> <ul style="list-style-type: none"> • inclusive tour requirements (ground package, tour organizer, etc.); • minimum tour price; • permissible changes from initial itinerary and facilities; • applicable tour conductor's discount; • other applicable rules or conditions (airline to specify). 	
<p>Applicability of general tariff rules and conditions</p>	<p>For ease of administration, States may wish to require that airlines present these in the form of specified exceptions, in the case of the particular fares concerned, to the general tariff rules dealt with in Section 2. The most common items against which exceptions arise, usually involving additional restrictions on users, are listed.</p>
<p>Airline to specify any exceptions in case of:</p> <ul style="list-style-type: none"> • conditions of carriage; • conditions of service; • baggage allowances and charges; • fare construction (including indirect routing options); 	

<i>Requirement</i>	<i>Commentary for the information of States</i>
<ul style="list-style-type: none"> • currency conversion; • agents' commission; • children's and infants' discounts; • circumstances under which waiver of minimum stay may be granted; • circumstances under which ticket validity may be extended; • reservation, payment and ticketing procedures; • voluntary re-routing conditions; • involuntary re-routing conditions; • cancellation and refund conditions; • passenger expenses en route; • inaugural flights; • agents' discounts; tour conductors' discounts; other general rules or conditions (airline to specify). 	

Presentation of proposed fare levels

- Economy excursion (round trip)
- Apex (round trip)
 - Introductory
 - High season
 - Low season

Basic requirements

The form below is designed for the provision by airlines of basic data regarding proposed fare levels and applies only to fares for travel originating in or destined for the country of filing. Where fare data are required for travel between third countries (for example, in relation to traffic carried by a national airline under Fifth Freedom traffic rights), the form could be readily adapted by using only the data columns under "For travel originating outside country of filing".

For comparative purposes, States generally find it expedient to require data by fare type for each city-pair as shown, but an alternative approach is to list data by city-pair within each fare type. Fare types should be listed by the airline along with trip type and any seasonal indicator and indicator of service or routing conditions. For example:

- First class (one-way, sleeper seat)
- First class (one-way)
- Intermediate (business) class (one-way)
- Normal economy (one-way, unrestricted)
- Normal economy (one-way, online)

Possible additional requirements

Where fares are evaluated on a regular basis or where detailed examination of a particular submission is to be carried out, States may require additional information which could vary according to circumstances. Each of the more commonly sought data elements identified below could be obtained through the addition of data columns and appropriate sub-headings to the above form of presentation:

- a) fares for travel originating outside the country of filing converted to equivalent levels in currency of sale of the country of filing at prevailing bankers' exchange rates, which should be specified;
- b) all fares in terms of one or more convertible currencies using, for example, IATA conversion rates;
- c) historic (previous year) data; and
- d) percentage change between proposed and current fare levels (and historic levels, if appropriate).

<i>CITY-PAIRS AND FARE TYPES</i>	<i>FOR TRAVEL ORIGINATING IN COUNTRY OF FILING (Point A to Point B)</i>		<i>FOR TRAVEL ORIGINATING OUTSIDE COUNTRY OF FILING (Point B to Point A)</i>	
	<i>Current level</i>	<i>Proposed level</i>	<i>Current level</i>	<i>Proposed level</i>
	<i>(in currency of sale in country of filing)</i>		<i>(in currency of sale in country of origin of travel)</i>	
City-pair (A-B):			Currency:	
Fare types:				
.....
.....
.....
<i>(continue for each city-pair and fare type as required)</i>				

Part II — Justification requirements

The following enumeration of possible justification requirements for proposed international scheduled passenger fares contains more information items than individual States are likely to require. In establishing their own justification requirements, States may wish to take into account that data may not be obtainable from airlines of other States, that certain information may be commercially sensitive and airlines may not wish it to become publicly available, and that the provision of data may be a particular burden on small airlines.

Detailed justification would normally be required only in special circumstances such as in connection with a radical change in a fare level or structure, the introduction of a fare for a new route, an airline appeal against a government disapproval of a fare, or the settlement of a dispute. Justification requirements may also differ between filings of fares flowing from multilateral airline agreements and those of fares agreed bilaterally or submitted by individual airlines.

Section 1. General information

Justification of a proposed fare would normally include an explanation of the rationale behind any new fare or any changed level or condition of a particular fare. In the case of a general change in fares, the rationale should be directly related to developments in the operating environment such as the introduction of new aircraft types, economic trends (including, in particular, trends in consumer prices in each country concerned), changes in currency exchange rates, or increases in specified costs such as the price of aircraft fuel, and should include the reasons for any major variation from the changes being sought in other areas.

Where relevant, comments should be provided on the competitive effects of the tariffs proposed or applied by other carriers with (scheduled or non-scheduled) operations on the same, overlapping and/or neighbouring routes. The impact of the proposed tariffs on user interests and any other anticipated effects would also be identified. Where appropriate, the filing airline should indicate whether there had been any consultation with user groups or associations of agents and the outcome of such discussions. Where changes to general tariff rules are proposed, any actual or potential impact on particular fares and/or on the fare structure should be explained.

Section 2. Specific data

For a fully effective evaluation, data on fare levels may need to be expanded beyond basic requirements as indicated in Section 3 of the tariff filing format dealing with the Presentation of Proposed Fare Levels (Part I above). Other fundamental information requirements, apart from the tariff filing and the general explanations referred to in Section 1 above, are the current and anticipated revenues, costs, traffic and capacity. Detailed data by individual city-pair or route would normally be required only in special circumstances as indicated above. More general data aggregated by group of routes would be useful on an annual basis and/or in conjunction with proposals for general changes in fares; such data should be readily available, particularly from airlines that submit data for ICAO's annual studies of regional differences in fares and costs or for IATA's Cost Committee.

Both the detailed and the more general data requirements are included in the possible form of presentation provided in the table on the following page. Together with the related explanatory notes, this table is designed to give States general guidance on data requirements and presentation. Specific requirements will vary from State to State and according to particular circumstances.

Presentation of justification data for proposed fares

	A. COMPARATIVE TIME PERIOD			
	Actual historic (year 1)	Estimated current (year 2)	Anticipated (year 3)	
			Without fare changes	With fare changes
<p>B. CURRENCY OF SUBMISSION:¹</p> <p>Exchange rate against other major currencies:</p> <p>Currency:¹</p> <p>(data continued as required for additional currencies)</p> ² ² ²	
<p>C. DATA BY INDIVIDUAL CITY-PAIR FOR EACH ROUTE</p> <p>Route:</p> <p>City-pair:</p> <p>a) number of revenue passengers:</p> <p> – estimated percentage of revenue passengers that originates in country of filing:</p> <p> – estimated percentage of revenue passengers that is prorata traffic:</p> <p>b) revenue from passengers:</p> <p> – estimated percentage of passengers that originates in country of filing:</p> <p>c) revenue from excess baggage:</p> <p>(data continued in above format as required for each city-pair)</p>
<p>D. SUMMARY BY ROUTE</p> <p>Route:</p> <p>Passenger-kilometres performed:</p> <p>Seat-kilometres available:</p> <p>Passenger load factor (%):</p> <p>Revenue from passengers and excess baggage:</p> <p>(data continued in above format as required for each route)</p>

	A. COMPARATIVE TIME PERIOD			
	Actual historic (year 1)	Estimated current (year 2)	Anticipated (year 3)	
			Without fare changes	With fare changes
E. SUMMARY BY GROUP OF ROUTES				
Group of routes:				
Passenger-kilometres performed: ³
Seat-kilometres available: ³
Passenger load factor (%):
Revenue from passengers and excess baggage: ³
Other revenues (freight, mail and pertinent incidental revenue):
Operating costs (broken down by cost item if required):
Return on investment (%):

1. For insertion of name or ISO code of currency.
2. For insertion of exchange rate per unit of currency of submission.
3. Compiled directly from D above.

Commentary for the information of States on the above justification data

Comparative time periods: For the evaluation of most types of tariff filing, States may require from airlines two or more chronological sets of data covering (i) a base reference period or periods; and (ii) a comparable period or periods after the intended effective date of the tariff proposal. The annual period shown here is the most expedient as it smooths out seasonal fluctuations. However, where tariff changes are proposed with greater than annual frequency or where the tariffs are for seasonal application, it would be valuable to have the revenue and traffic data broken down amongst the periods for which the fares concerned were or would be applicable. Since a “current” year’s data would almost always, in part at least, include estimated elements, it could be useful, as shown here, to establish a base through the provision by airlines of “actual” data for the previous year. It would also be useful to request “anticipated” data both with and without the proposed tariffs implemented. For new fare types, it may be valuable to consider “anticipated” data for a period beyond the first year of planned effectiveness in order to assess the consequences in a fully matured situation.

Currency of submission: All revenue and cost data would normally be provided by the airline in the currency of sale in the country of filing (consistent with the currency used for the tariff filing in Part I for travel originating in the country of filing) or the national currency of the country of filing as required. Where the rate of exchange against major currencies, such as the United States dollar, has a significant impact on traffic, revenues or costs, and is not steady, historic and assumed future exchange rates should be provided, and revenue and cost data may need to be broken down (to the extent possible) by the currency of the submission and other major currencies concerned.

Data by individual city-pair for each route: These data could be required for a single tariff proposal which is likely to have a significant effect on the traffic or operating economics between a city-pair. As with the tariff filing itself (Part I), the data would generally apply to those city-pairs involving travel to and from the territory of the country of filing, but some States may require data for additional city-pairs. Where at least one origin and destination are common to more than one route, States may find it convenient to request airlines to amalgamate the data for the routes concerned.

Traffic data are presented here in terms of numbers of on-flight origin and destination passengers between each city-pair; particularly when broken down by origin as shown, this enables evaluation of the impact of the tariff proposal on the national aviation infrastructure (for example, airport capacity) and on the national economy (for example, tourist flows). The concomitant revenue data enable direct measurement of the impact of the proposal on revenue yield for comparison both chronologically and against revenue yield for other city-pairs. The difference between fare levels and revenue levels is determined by commission payments, discounts (such as those for children), and the impact of prorating. The latter, in particular, varies significantly from route to route and has a direct effect on the level of fares to be offered; hence, it can be useful to measure its impact, which may be done through the provision of an estimate of the percentage of prorate traffic as shown.

A further breakdown into revenue and traffic by fare type may be necessary, including estimates of the anticipated diversion of traffic between fare types as well as of the overall impact on traffic. Some States require a breakdown on a regular basis but in most other cases such data would only be required where major changes to the fare structure are being proposed. Freight revenue and traffic data may also need to be taken into account, particularly where combination passenger/freight (“combi”) aircraft are concerned.

Summary by route: These data could be required for a tariff proposal which is likely to have a significant effect on the operations or economics of a route as a whole; the data should cover all city-pairs on the route concerned.

Traffic data are presented here in terms of passenger-kilometres. Together with capacity data in terms of seat-kilometres, they enable calculation of the passenger load factor and the impact of the tariff proposal on the operations of the route. Together with the revenue data, they give some insight into the economics of the route. Freight revenue and traffic data may also need to be taken into account, particularly where combination passenger/freight aircraft are concerned.

Summary by group of routes: These data would normally be required only on an annual basis and/or in conjunction with proposals for general changes in fares. Substantive insight into the economics of a route is gained here by the addition of non-passenger related revenues and

of operating costs. Such data are normally provided only at the aggregate route group level, primarily because operating costs cannot be segregated with any great degree of precision because of the generic or joint nature of many cost elements (for example, general administrative costs or combined passenger/freight (“combi”) aircraft flight costs). However, provided the cost allocation methods and criteria are identified and consistently employed, valid comparisons over time may be made.

Where proposals for general changes in fares are made to reflect changes in costs, and particularly where they are designed to respond to specific cost changes such as increases in fuel prices, operating cost data would need to be broken down by cost item. Some States may wish to designate (or agree with the airline on) a specific format for the systematic identification of cost items.

Short-term anomalies affecting costs should be eliminated. For example, the major change between short-run and long-run costs might be high start-up costs for the introduction of new aircraft which would be the main equipment used on the route for a substantial period. Return on investment would be calculated in accordance with national practice and would normally cover such items as return to shareholders and contribution towards the cost of re-equipment.

**Part III — Minimum elements of
an electronic tariff filing**
(as specified by ECAC guidelines)

As a minimum, a tariff filing should contain:

- a) *A filing identification.* An identification, such as the IATA filing advice number, unique to a particular filing and generated when filing takes place through an automated filing system. Once the identification has been issued, it cannot be changed.
- b) *A date and time stamp.* Generated by the automated tariff filing system and indicating the date and time of completion of a tariff filing and its entry into the filing systems’ database. Once the stamp has been issued, it cannot be changed.
- c) A carrier code.

- d) A *justification element*. Provided by the filing carrier(s) to justify the introduction, deletion or amendment of a filing.
 - a *one-way/round trip indicator* (to identify whether the fare or add-on is one-way or round trip);
- e) A *point of contact element*. Containing the name and telephone number of the person dealing with the filing at the carrier(s) concerned.
 - where a change in fare or add-on amount is involved, the *existing fare* or *add-on* should also be given, together with the *percentage change*;
- f) A *geographical identification*. Showing the point of origin and the point of destination, or a wider geographical area, as applicable.
 - 2) a *rule element* (to add, change or delete a rule);
 - 3) a *routing element* (to add, change or delete a routing for a specific fare);
 - 4) a *footnote element* (to add, change or delete a footnote)
 - together with the proposed corresponding *date(s) of effectiveness* and *expiry date(s)*, if any.
- g) A *fare class code*. An alphanumeric code used by the carrier(s) to reflect a carrier-specific tariff.
- h) At least one of the following:
 - 1) a *fare* and/or *add-on* element (to add, change or delete a fare and/or add-on). Where the filing contains either a fare or add-on element (or both), it should also include:
 - a *currency code* (showing the applicable currency code);

For a filing of general conditions, such as commission, baggage rules and fare construction rules, the requirements in points f) and g) need not apply.

Appendix 2

IATA CURRENCY CONVERSION SYSTEM

Since airlines and air transport intermediaries (e.g. travel agents, freight forwarders) often have to make conversions from one currency into another when calculating international passenger fares and cargo rates, IATA has developed rules and procedures for making currency conversions. The *IATA currency conversion system enables fares or rates to be quoted in one single currency for multi-sector trips/shipment involving one or more airlines, or for trips originating in another country.*

Currency conversion system for cargo rates and charges

IATA introduced the system in 1984, which enables all cargo rates and charges to be expressed in local selling currencies. When it is necessary to combine or compare cargo rates expressed in different currencies for rate construction purposes, such rates are converted into a common unit, United States dollars, by using the exchange rates published by the IATA Clearing House; the necessary calculations are performed in dollars.

Currency conversion system for passenger fares

Under this system which was introduced in July 1989, all IATA passenger fares are established and quoted in the currency of the country where passengers commence their travel, except in some countries and territories with relatively weak currencies where fares are established in U.S. dollars instead. A traveller may pay the fare in local currency or in some other acceptable currency based on conversion at the bank exchange rate. For ticket sales made outside the country where travel actually commences (i.e. "foreign" sales), the fare in that country's currency is converted into the currency of the country of sale at the bank exchange rate on the day the ticket is issued

(see example 1). Where a trip involves a combination of different currency fares, each fare is converted into the currency of the country of commencement of travel by using the IATA Clearing House rates of exchange against the U.S. dollar (see example 2). These rates, reflecting recently prevailing bank exchange rates, are issued quarterly by IATA and normally remain unchanged for three months. However, if a currency weakens or strengthens against the U.S. dollar by more than 10 per cent during the three-month period, a new exchange rate is issued for that currency.

Examples of currency conversion for passenger fares

The following two simple examples illustrate how the IATA system works.

Example 1 — Foreign sale

A passenger in Montreal buys a New York to London ticket:

Local fare (in Canadian dollars) = New York-London local fare (in U.S. dollars converted into Canadian dollars at the bank exchange rate on the day the ticket is issued).

Example 2 — A combination of different currency fares

A passenger in Montreal buys a Montreal-London-Tokyo-Sydney (A-B-C-D) ticket (in the absence of a through-fare):

Local fare (in Canadian dollars) = A to B local fare (in Canadian dollars) + B to C local fare (in U.K. pounds sterling converted into Canadian dollars using the IATA exchange rate) + C to D local fare (in Japanese yen converted into Canadian dollars using the IATA exchange rate).

Regulatory implications

Certain rules governing the application of the currency conversion system for passenger fares are of regulatory interest to governments, for example:

- a requirement that if a directional difference in fares exists whereby an outbound one-way fare is higher than the corresponding inbound one-way fare, a passenger must be charged the higher of the two fares whenever a one-way ticket is sold or issued outside the country of commencement of travel;
- a requirement that fares will only be valid when travel originates in the country of origin shown on the ticket; and

- a requirement that if a fare for a passenger's routing is less than a comparable fare between any two ticketed points on the routing (a "higher intermediate fare"), the level of the passenger's fare must be raised to that of the higher intermediate fare.

Largely designed to protect airline revenues and minimize abuse of the system (e.g. from countries with weak currencies and depressed fare levels), these rules could have implications for governments in respect of enforcement or competition policies. In the latter case, for example, they may be considered as placing restrictions on consumer choices (e.g. in the European Union, competition law requires that consumers must be free to purchase goods and services wheresoever they wish and to enjoy locally prevailing prices and terms of sale). To meet such concerns, some provisions were made by IATA to exclude the application of the above rules in certain States.

Appendix 3

PRORATING

Many international journeys by passengers and shipments of cargo involve transportation on more than one air carrier at a single through-fare or rate. This creates a need for a method of *“prorating” revenues*, i.e. *allocating total revenues earned for the carriage of passengers or freight between origin and destination among two or more air carriers which provide the transportation for different segments of a journey.*

To facilitate such interline journeys and to reduce the administrative burden of revenue-sharing procedures on airlines, two Multilateral Proration Agreements have been developed by the airline industry, one for passengers and one for cargo, which together provide revenue allocation rules for interline fares and rates worldwide. The Prorate Agency’s terms of reference are specified in the Prorate Agency Agreement, and its administrative expenses funded directly by airlines signatory thereto. The agreements are open to all airlines operating scheduled services.

The prorate agreements, as voluntary private commercial agreements which do not set or modify tariffs but apply agreed rules on sharing revenue derived from approved tariffs, are not filed with governments for approval.

The agreements allocate revenues in basically two ways: by using solely prorate factors based on distance and costs (referred to as straight rate proration) or by using the factors in conjunction with provisos or requirements filed by individual airlines. These provisos or requirements

specify a share for the filing airline (a percentage or a stated amount) to be deducted from the amount to be prorated before the application of the prorate factor.

A minimum prorate rule is used in conjunction with provisos and requirements to ensure that an airline performing a segment will receive a certain minimum amount equivalent to about 30 per cent of the applicable fare for the segment it operates.

For cargo, prorate factors are determined by distance, weighted by costs provided by aircraft manufacturers. For passengers, a more elaborate formula is used based on distance, weighted by a three-year worldwide average total cost factor plus an area factor developed from a three-year average of direct operating costs (such as fuel, landing and airport charges, and en-route facility charges) for 17 regions. Cost data collected by ICAO are used in developing the passenger prorate factors.

The prorate agreements also contain a number of associated rules on how the prorate factors are to be applied, for example, in the case of stopovers, discounts for infants, voluntary and involuntary re-routings, and round trips.

In cases where an airline is not a member of the prorate agreements, bilateral arrangements between concerned airlines are made for the division of revenues derived from interline transportation.

Appendix 4

GUIDANCE MATERIAL FOR USERS OF AIR TRANSPORT

This guidance material was issued by decision of the Council to assist States in publishing or encouraging the publication of booklets intended to inform air transport users of their rights and obligations. The material was developed in the mid-1980s having regard to the increasing complexity of tariff rules and conditions and the need expressed by States to ensure that the public is fully informed of the rules and conditions when purchasing air transport services. Although both the air transport industry and its regulation have undergone significant changes in the last two decades, this material can still serve as a useful checklist for States, where applicable, because the issue of consumer interests continues to be relevant and, in fact, has attracted increasing regulatory attention in recent years (see Chapter 4.9).

The guidance material consists essentially of two inventories of possible contents of information booklets, one designed for air passengers (Part I) and the other for air shippers (Part II), the latter aimed particularly at shippers with small or infrequent shipments. The inventories include matters that may be of interest or importance for selection and development according to local circumstances and conditions, and tariff-related aspects are enlarged upon in an annotated descriptive text. The inventories have been compiled from ICAO conclusions and recommendations, airline rules and regulations, and several existing information booklets published in various countries.

In 1992 the Latin American Civil Aviation Commission, a regional inter-governmental aviation organization, produced

for the guidance of its members a “Charter of Rights for the Air Transport User” which included many of the items in the inventories developed by ICAO.

In considering whether information booklets should be developed in their own countries, States will wish to take into account the various means by which such booklets might be developed and disseminated, bearing in mind the need to ensure an appropriate balance of public interest and to ensure that any guidance material is brief, readily comprehensible and widely available.

In some countries, such documents have been developed and published as a public service by the government transportation or consumer protection agency concerned, while in other cases independent consumer action groups have been responsible for the documents, funded by government subsidy and/or public donations. All of these publications are made available on request, free of charge, to the general public. Government publications generally make it clear that they are for information only, are not binding, and do not override airlines’ approved tariff rules or conditions of carriage.

In some other cases, documents have been developed by individual airlines or freight forwarders and made available free of charge on their own aircraft and/or in their sales outlets. Further means of development and distribution are through user groups, such as business associations or associations of shippers, and through commercial publishers.

Part I — Possible contents of publications for guidance of air passenger

Background	Introductory description of the fare-setting process, including the role of airlines, IATA and other airline associations, governments and, as appropriate, organizations representing user interests.
Scheduled versus charter	Introductory description of differences between scheduled and non-scheduled operations, including a description of different charter types and of inclusive tour arrangements, and the fact that for charter flights the contract is with the charterer rather than with the air carrier.
Role of intermediaries	Description of the functions of travel agents and travel organizers/tour operators/charter organizers, any licensing and escrow/bonding requirements, implications of accreditation by IATA and other programmes, etc.
Prices and conditions	<p>a) Advice that on most routes two or more classes of travel and a wide range of fares are available, with descriptions indicating the advantages of normal fares (for example, unlimited stopovers/transfers, indirect routing allowances, no charge for cancellation/change of flight, etc.) and of “restricted” normal economy fares in some markets which retain most of the characteristics historically associated with normal economy fares but have restrictions, for example, on the availability of stopovers or, in some cases, on the ability to interline as well as the price advantages and restrictive conditions attached to special fares (for example, circle trip/round trip requirements, seasonal application, stopover/transfer limitations, minimum and maximum stay periods, advance reservation and payment provisions, cancellation charges and forfeits, group requirements, ground purchase or other additional purchase requirements, etc.). Description of varying availability of discounts for infants, children, students/youth, etc., and of preferential fares.</p> <p>b) Advice to check, in advance of purchase, which conditions apply.</p> <p>c) Where charges or forfeits apply for change in ticket validity or for ticket change/cancellation, advice to check whether exceptions are granted (for example, in cases of illness or death) and whether insurance against unforeseen changes in plan is available through the airline and/or directly from the insurance company (and, if so, what it covers).</p> <p>d) Advice that in many areas certain taxes and/or charges (for example, airport service charges) are not included in the price of the ticket; in such cases, they may be added at the time of purchase and/or collected at the airport prior to departure.</p>
Currency of payment	Advice that, except in countries where it is specifically excluded, payment may be made in a range of currencies. Where this is not the case, advice as to what restrictions and procedures with respect to currency apply to the purchase and refund of tickets.
Tickets	a) Advice that the air ticket is the passenger’s evidence of his or her contract with the air carrier or charterer (see also “Conditions of carriage” below).

- b) Advice regarding implications of purchase of irregularly issued tickets.
- c) Brief explanation of the main elements of notation on the ticket (for example, boxes showing passenger's name, airports, airlines, flight numbers, codeshared flights and their significance for the traveller, class of travel, departure dates and times, status, validity, etc.).
- d) Advice that a file reference number should be obtained and noted when making a reservation or reconfirmation.
- e) Advice that most airlines have established deadlines by which tickets must be paid for in full (and in some cases collected) failing which the reservations concerned are subject to cancellation.

Tickets issued at fares subject to government approval

Advice that in many countries fares may be advertised and tickets sold at fares which have yet to receive government approval; that such advertisements and tickets should be clearly annotated that the fares are "subject to government approval"; and that purchasers of such tickets should ensure that they are aware of the potential consequences of the unapproved status of the fares (for example, possible non-applicability, possible surcharge, rights to refund).

Tickets issued prior to announcement of fare increases

Advice that as a general rule tickets paid for may be subject to surcharge where a fare increase is subsequently approved, but that exceptions to this rule exist in a number of countries.

Lost tickets/refunds

Advice concerning rights to refunds and procedures to be followed to obtain refunds. Description of differences between "voluntary" and "involuntary" refunds and refunds for lost or stolen tickets, service charges, periods within which applications must be made, and expectation of delays in processing.

Check-in

Advice concerning airline check-in requirements and consequences of failure to observe them, such as cancellation of the reservations for that and any subsequent flights on the itinerary.

Free baggage allowances and excess baggage charges

- a) Advice on the existence of different methods of establishing free baggage allowances and excess baggage charges under the so-called piece and weight systems, on airline variations under both systems, and on the possibility that different allowances may apply on different sectors of an interline journey or on the return journey.
- b) Advice to ascertain in advance from the airline or its agent the detailed allowances which apply throughout the intended journey, both for carry-on baggage and for checked baggage.
- c) Advice that an airline at its discretion may accept excess baggage at charges related to the system being applied and according to its regulations.
- d) Advice that passengers travelling together may pool their free baggage allowances.

- e) Advice that personal effects may be shipped as cargo, generally at lower cost than for shipment as excess baggage, but under more onerous circumstances.
- f) Advice on the existence of limited liability by the airline for lost or damaged baggage, levels of which may be ascertained from the carrier or its agent. Advice on liability exclusions regarding checked baggage (for example, for certain perishable and valuable items), on the available option of declaring a higher value for baggage on payment of an additional charge and/or, where available, taking out insurance.

Right to refuse carriage

Advice that under certain circumstances airlines may refuse carriage, in relation to the conduct, age, or mental or physical state of the passenger.

No-shows, overbooking, and compensation for denied boarding

- a) Advice which includes a description of a “no-show” and how to avoid being a “no-show”.
- b) Advice that to compensate for no-shows most airlines often overbook flights, that as a result passengers with confirmed reservations are occasionally denied boarding because of non-availability of seats, and that in certain countries and for certain airlines compensation for such denied boarding is available. Advice that passengers may wish to ascertain, before accepting compensation, their rights at law where major financial or other losses are incurred as a consequence of denied boarding.

Delay/cancellation

- a) Advice that when (due to circumstances beyond their control) airlines cancel or delay a flight or cause a passenger to miss a connection, most airlines accept the obligation to refund or provide alternative flight arrangements at no further cost to the passenger, but do not generally accept any further liability for any damages incurred as a result (for example, lost vacation or work time). Advice that where major financial or other losses are incurred as a consequence of delay, passengers may wish to ascertain their rights at law.
- b) Advice that in case of delay to passengers, most airlines customarily provide certain amenities, such as the free provision or reimbursement of the cost of communications, meals, refreshments, transit taxes and, usually in circumstances of prolonged delay during the night hours (at points which are not origin, destination or stopover points), hotel accommodation and ground transportation.
- c) Advice that in the case of delayed baggage, airlines may, in certain circumstances, provide or reimburse passengers for the purchase of personal necessities.

Reconfirmation

Advice that many airlines require reconfirmation of an onward reservation wherever a journey is broken for more than 72 hours, and that failure to comply may result in cancellation of the reservation in question, together with those for any subsequent flights in the journey.

Complaints and redress	Advice as to complaint procedures and avenues for action, including information on differing time periods within which formal claims must be made.
Conditions of carriage	<p>a) Advice that passengers (and air carriers or charterers) are bound by conditions appearing on the ticket, by tariff conditions, by carrier or charterer regulations and, outside Canada and the United States, by conditions of carriage, all of which should be readily available from the carriers or charterers for reference.</p> <p>b) Advice that all these conditions may vary for different segments of a journey, if provided by more than one airline.</p>
Liability	Brief summary of limits of liability as provided for by international treaty (supplemented in some instances by other arrangements) and available for reference in summary on the ticket coupon and in detail in air carrier conditions of carriage (air carrier tariffs in Canada and the United States).
Glossary	Description of commonly used air carrier terms and abbreviations.
Checklist of non-tariff matters	Advice regarding: <ul style="list-style-type: none">• Travel documentation — passports (including information on machine readable passports, where applicable), visas, medical certificates, driving licences, diplomatic/consular representation in foreign countries, etc.• Health-vaccination requirements, medical treatment, health risks and protection.• Insurance.• Foreign currency and currency restrictions, traveller's cheques, use of credit cards.• General customs requirements and duty-free purchase allowances, dual-channel clearance system.• Facilities, conditions and procedures for carriage of unaccompanied minors, pregnant women, the obese, and sick and/or handicapped persons.• Carriage of pets.• Hotel reservations and car hire.• In-flight services (meals, including availability of special meals, drinks, entertainment, etc.).• Seat reservation and selection, smoking regulations.• How to pack and label, what to pack in carry-on baggage, what to wear.• Carriage of dangerous goods.• Control of illicit traffic in narcotic drugs.• Facilities available at airports.• Key to flight displays and standard signs at airports.• Check-in and boarding procedures, including security arrangements.• Safety on board.• Procedures to be followed in the event baggage is lost.• Effects of alcohol.• Jet lag.

Part II — Possible contents of publications for guidance of air shippers

Background	Introductory description of the rate-setting process, including the role of airlines, IATA and other airline associations, freight forwarders/consolidators, governments and, as appropriate, organizations representing user interests.
Scheduled versus charter	Introductory description of differences between scheduled and non-scheduled operations, including a description of different charter types and the fact that for charter flights the contract is with the charterer rather than with the air carrier.
Small package/courier services	Description of availability of such services and how they differ from more general air freight services.
Role of intermediaries	Description of the functions of cargo agents, freight forwarders/consolidators, any licensing and escrow/bonding requirements, implications of accreditation by IATA and other programmes, etc.
Rates, charges and conditions	<ul style="list-style-type: none"> a) Advice that on most routes a range of rates is available with discounts for large volumes, for many types of commodities, and for use of containers or pallets. b) Advice that rates are determined by factors including minimum charges, weight, density, packaging and the degree to which the item is considered difficult to handle (in relation, for example, to oversized objects, livestock or dangerous goods). c) Advice that basic rates usually cover air transportation (airport to airport) only and any other services such as collection, delivery, ground handling, customs clearance and storage are generally subject to additional charges, except in the case of small package/courier services where door-to-door service is provided. d) Advice that gifts sent as cargo are usually liable to clearance or handling charges at destination whether there is any duty payable or not.
Reservations	<ul style="list-style-type: none"> a) Advice that advance arrangements are generally required for certain types of shipments (for example, oversized objects, livestock, valuable or dangerous goods) and that many airlines also accept reservations for other shipments. b) Advice that where space is reserved in advance, a file reference number should be obtained and noted.
Charges prepaid and charges collect	Advice that total rates and charges may be paid in advance in the country of shipment (or in a third country) or, in many countries and on payment of a service charge, on delivery of the shipment in the country of destination.
Currency of payment	Advice that, except in countries where it is specifically excluded, payment may be made in a range of currencies, converted at the prevailing bankers' rate of exchange to the local selling currency.
Air waybill	<ul style="list-style-type: none"> a) Advice that the air waybill is the shipper's evidence of his or her contract with the air carrier, forwarder or charterer (see also "Conditions of carriage" below).

- b) Brief explanation of the main elements of notation on the air waybill (for example, boxes showing the shipper's, consignee's and forwarder's names and addresses, airports, airlines, flight numbers, rate class, consignment data, etc.).

Delay

Advice that, while airlines are obliged "to complete the carriage with reasonable dispatch", they bear no explicit responsibility for delay except, in the case of a few routes and airlines, for certain "priority" services offered with or without additional charge. Advice that where major financial or other losses are incurred as a consequence of delay, shippers may wish to ascertain their rights at law.

Refunds

Advice concerning rights to refunds and procedures to be followed to obtain refunds, service charges, periods within which applications must be made, and expectation of delays in processing.

Complaints and redress

Advice as to complaint procedures and avenues for action, notably in respect of lost, delayed or damaged cargo (including concealed damage discovered after delivery), incorporating information on differing time periods within which formal claims must be made.

Conditions of carriage

- a) Advice that shippers (and air carriers, forwarders or charterers) are bound by conditions appearing on the air waybill, by tariff conditions, by air carrier and charterer regulations and, outside Canada and the United States, by conditions of carriage, all of which should be readily available from the carriers, forwarders or charterers for reference.
- b) Advice that all these conditions may vary for different segments of the carriage, if provided by more than one airline.

Liability

- a) Brief summary of limits of liability as provided for by international treaty (supplemented in some instances by other arrangements) and available for reference in summary on the air waybill and in detail in air carrier conditions of carriage (air carrier tariffs in Canada and the United States).
- b) Summary of liability arrangements for forwarders/consolidators.
- c) Advice on liability exclusions, on the option of declaring a higher value for cargo on payment of an additional charge and/or taking out insurance, which may be available through the carrier.

Glossary

Description of commonly used air carrier terms and abbreviations.

Checklist of non-tariff matters

Advice regarding:

- Documentation — shipper's letter of instructions, commercial invoices, certificates of origin, consular invoices, letters of credit, etc.
- Carriage of dangerous goods.
- Restrictions on acceptance for carriage.
- Control of illicit traffic in narcotic drugs.
- Choice of routing and implications of transit.
- Import restrictions and duties.
- Automated customs clearance procedures, including legal implications.
- Insurance.

- Packaging.
 - Carriers and forwarders' credit policies.
 - Consequences of failure to collect shipment.
 - Benefits of shipping by air, the total distribution cost concept.
-

INDEX

INDEX

A

- A posteriori* 3.2-2
A priori 3.2-2
Ab initio 3.2-2
Acceptance or approval 3.1-4
Accession 3.1-4
Accreditation 3.1-2
Act 3.2-2
Ad referendum agreement 2.1-5
Addendum 3.1-2
Additional Protocol No. 1 3.2-4
Additional Protocol No. 2 3.2-4
Additional Protocol No. 3 3.2-4
Add-on fare 4.3-3
Adopted agenda 3.1-2
Advance booking charter (ABC) 4.6-2
Advance purchase excursion fare (APEX fare) 4.3-4
Aerodrome 5.4-1
Aeronautical authorities 1.2-1
Aeronautical Commission of the Peace Conference 3.0-2
Aeroplane 5.2-1
AFCAC Bureau 3.6-1
AFCAC Plenary 3.6-1
Affinity group charter 4.6-2
African Air Tariff Conference 3.6-1
African Airlines Association (AFRAA) 3.9-1
African, Caribbean and Pacific Group of States
(ACP Group) 3.7-6
African Civil Aviation Commission (AFCAC) 3.6-1
Agenda 3.1-2
Agreed fare 4.3-3
Agreed joint press release 2.1-5
Agreed minute 2.1-5
Agreed press release 2.1-5
Agreement 3.2-2
Agreement ad referendum 2.1-5
Agreement among Directors General of Civil Aviation
of the Kingdom of Cambodia, the Lao People's
Democratic Republic, the Union of Myanmar, and
the Socialist Republic of Viet Nam on the
Establishment of Subregional Air Transport
Cooperation 3.2-6
Agreement on airline crew visas 2.2-4
Agreement on the avoidance of double taxation
relating to air transport services 2.2-4
Agreements on certificates of airworthiness 2.2-5
Agreements on communications 2.2-5
Agreements on duties on fuel 2.2-5
Agreements on meteorology 2.2-5
Agreements on search and rescue 2.2-5
Aide-mémoire 2.1-5
Air cargo 4.5-1
Air carrier 5.1-1
Air carrier capacity 4.2-1
Air Charter Carriers Association (ACCA) 3.9-1
Air operator certificate (AOC) 4.7-6
Air service 5.3-1
Air Services Agreement 2.2-1
Air taxi service 5.3-2
Air transport (iv)
Air Transport Agreement 2.2-1
Air Transport Association of America (ATA) 3.9-1
Air transport authorities 1.2-1
Air Transport Bureau 3.4-3
Air Transport Committee 3.4-2
Air transport conference 3.4-2
Air transport market 4.1-1
Air transport market access 4.1-1
Air transport market penetration 4.1-1
Air Transport Regulation Panel 3.4-2
Air waybill 4.3-2
Aircraft 5.2-1
Aircraft interchange 4.1-8
Aircraft leasing 4.7-5
Aircraft repair and maintenance services 3.3-4
Airline alliances 4.8-1
Airline product distribution 4.7-3
Airport 5.4-1
Airport capacity 5.4-1
Airport Economics Manual (Doc 9562) 3.4-4
Airport Economics Panel 3.4-2
Airport Operators Council International (AOCI) 3.9-2
Airport slot 4.10-2
Airport slots article 2.2-3
Airports Association Council International (AACI) 3.9-2
Airports Council International (ACI) 3.9-2
Airworthiness article 2.2-3

All-cargo aircraft 5.2-1
 All-cargo service 4.5-1
 Alternate airport 5.4-1
 Amendment article 2.2-4
 Amendment clause 2.2-4
 Amendment to a treaty 3.1-4
 Andean Committee of Aeronautical
 Authorities (CAAA) 3.6-2
 Andean Community 3.7-4
 Annex 2.2-4
 Application of laws article 2.2-3
 Approved tariff 4.3-8
 Arab Air Carriers Organization (AACO) 3.9-1
 Arab Civil Aviation Commission (ACAC) 3.6-2
 Arab Civil Aviation Council 3.6-2
 Arab Common Market (ACM) 3.7-6
 Arab Maghreb Union (AMU) 3.7-1
 Arbitral tribunal 2.1-7
 Arbitrary fare 4.3-3
 Arbitration 2.1-7
 Area 1 3.8-2
 Area 2 3.8-2
 Area 3 3.8-2
 Area Conferences 3.8-2
 Areeda-Turner rule 4.3-11
 Arrangement 3.2-2
 Article 2.2-2
 Article 3 *bis* 3.2-4
 Article 83 *bis* 3.2-3
 Asean Free Trade Area (AFTA) 3.7-2
 Asia-Pacific Economic Cooperation (APEC) 3.7-2
 Asociación Internacional de Transporte Aéreo
 Latinamericano (AITAL) 3.9-1
 Assembly 3.4-1
 Association Internationale de Transporteurs
 Aériens (ATAF) 3.9-1
 Association of Asia Pacific Airlines (AAPA) 3.9-1
 Association of European Airlines (AEA) 3.9-2
 Association of South East Asian Nations
 (ASEAN) 3.7-2
 Association of South Pacific Airlines (ASPA) 3.9-2
 Authentication 3.1-4
 Authorized capacity 4.2-2
 Autonomous airport authority 4.10-4
 Autonomy 4.10-4
 Available seat-kilometres (ASKs) 5.1-3
 Available tonne-kilometres (ATKs) 5.1-3
 Average load factor 4.2-1
 Average variable cost 4.3-11
 Aviation (iv)
 Aviation security agreement 2.2-5
 Aviation security article 2.2-3

B

Back end 4.3-5
 Banjul Accord 3.2-6
 Banjul Accord for an Accelerated Implementation
 of the Yamoussoukro Declaration 3.2-6
 Banks 5.4-2
 Basic fare 4.3-7
 Basic market access right 4.1-1
 Behind point 4.1-4
 Bermuda Agreement 2.2-1
 Bermuda I Agreement 2.2-1
 Bermuda I type Agreement 2.2-1
 Bermuda I type method 4.2-2
 Bermuda II Agreement 2.2-1
 Bermuda-type Agreement 2.2-1
 Beyond point 4.1-3
 Bilateral 2.2-1
 Bilateral clause 2.2-2
 Bilateral interlining 4.3-9
 Bilateral negotiation 2.4-1
 Bilateral regulation 2.0-1
 Bilateral/multilateral fare 4.3-3
 Billing and Settlement Plan (BSP) 3.8-4
Bis 3.2-2
 Blind sector 4.1-12
 Blind sector traffic 4.1-12
 Blocked space 4.1-7
 Booking classes 4.2-5
 Break point 4.3-5
 Break-even load factor 4.2-2
 Bucharest Convention of 1936 3.0-2
 Bucket shops 4.3-5
 Buenos Aires Convention of 1935 3.0-2
 Bundled fare 4.3-3
 Bus (BUS) 4.1-8
 Business-to-business (B2B) 4.7-4
 Business-to-consumer (B2C) 4.7-4
 Business-to-business-to-consumer (B2B2C) 4.7-4

C

Cabotage 4.1-10
 Cabotage privilege 4.1-10
 Cabotage right 4.1-10
 Cabotage traffic 4.1-10
 Capacity allocation 4.2-2
 Capacity article 2.2-3
 Capacity regulation 4.2-1
 Capital lease 4.7-5
 Cargo Accounting Settlement System (CASS) 3.8-4

- Cargo agents 4.5-2
 Cargo air carrier 5.1-1
 Cargo air service 5.3-1
 Cargo flexibility 4.1-4
 Cargo hub 5.4-2
 Cargo throughput 5.4-1
 Caribbean Community and Common Market
 (CARICOM) 3.7-5
 CARICOM Multilateral Air Services Agreement
 (MASA) 3.2-6
 Carrier fare 4.3-3
 Cartagena Agreement 3.7-4
 Central African Customs and Economic Union
 (CACEU) 3.7-1
 Central African Economic Union (CAEU) 3.7-1
 Central American Air Transport Commission
 (COCATRAE) 3.6-2
 Central American Common Market (CACM) 3.7-5
 Central American Integration System 3.7-5
 Central European Initiative (CEI) 3.7-3
 Certificated carrier 5.1-1
 Chairpersons' meeting 2.1-4
 Change of gauge 4.1-5
 Chapter 2 aircraft 5.2-2
 Chapter 3 aircraft 5.2-3
 Charter 3.2-2
 Charter 4.6-1
 Charter Agreement 2.2-1
 Charter carrier 5.1-1
 Charter fare 4.3-5
 Charter flight 4.6-1
 Charter of the United Nations 3.5-1
 Charter rate 4.3-5
 Charter/travel organizer 4.6-2
 Charterworthy 4.6-3
 Chicago Agreement 2.2-1
 Chicago Conference 3.0-2
 Chicago Convention 3.2-3
 Chicago-type Agreement 2.2-1
 Circle flight 4.1-12
 City-pair market 4.1-1
 Civil aviation authorities 1.2-1
 Class rate 4.3-5
 Clause 2.2-2
 Clearing House 3.8-4
 CLMV Agreement 3.2-6
 Club interlining 4.3-9
 Club of Paris 3.7-6
 Co-branding 4.5-1
 Codesharing 4.1-7
 Combi aircraft 5.2-1
 Combination aircraft 5.2-1
 Combination service 5.3-1
 COMESA Agreement 3.2-6
 Comingling 4.6-2
 Comity 1.1-3
 Commercial air service 5.3-1
 Commercial airport 5.4-1
 Commercial operations article 2.2-3
 Commercial opportunities article 2.2-3
 Commercial presence 3.3-5
 Commercial transport aircraft 5.2-1
 Commercialization 4.10-4
 Commission override 4.3-5
 Commission Regulations 3.7-4
 Commissions 4.3-2
 Committee of the Regions (COR) 3.7-4
 Common carrier 5.1-2
 Common Foreign and Security Policy (CFSP) 3.7-3
 Common Market for Eastern and Southern Africa 3.7-2
 Common purpose charter 4.6-2
 Commonrating 4.3-7
 Commonwealth Independent States (CIS) 3.6-2
 Community carrier 5.1-2
 Commuter aircraft 5.2-2
 Commuter carrier 5.1-2
 Composite Meetings 3.8-2
 Computer reservation system (CRS) services 3.3-4
 Computer reservation systems article 2.2-3
 Computer reservation systems (CRSs) 4.7-3
 Conditions of carriage 4.3-2
 Conditions of contract 4.3-2
 Configuration 4.2-5
 Congested airport 5.4-1
 Connecting traffic 4.1-11
 Consecutive cabotage 4.1-10
 Consignee 4.3-2
 Consignor 4.3-2
 Consolidator 4.3-4
 Constructed fares 4.3-3
 Consultation 2.1-1
 Consultation article 2.2-3
 Consultation (negotiation) working paper 2.1-5
 Consultation round 2.1-4
 Consumers International 3.9-2
 Consumption abroad 3.3-5
 Container rate 4.3-5
 Containers 4.5-1
 Contract for carriage 4.3-2
 Contracting parties 2.2-2
 Convention 3.2-2
 Convention on International Civil Aviation 3.2-3
 Convention on the Marking of Plastic
 Explosives for the Purpose of Detection 3.2-5

Conversion factor	4.2-2
Conversion formula	4.2-2
Cooperation Council for the Arab States of the Gulf (GCC)	3.7-5
Corporatization	4.10-4
Corrigendum	3.1-2
Co-terminal	4.1-4
Co-terminal point	4.1-4
Council	3.4-2
Council Directives	3.7-4
Council of Arab Ministers of Transport	3.7-6
Council of Europe (CE)	3.7-3
Council of the Entente (CE)	3.7-1
Council of the European Union	3.7-4
Council on Aviation and Airspace Use (CAAU)	3.6-2
Council Regulations	3.7-4
Country of designation	4.3-6
Country of origin	4.3-6
Country-pair market	4.1-1
Coupon or flight sector origin and destination	4.1-10
Courier	4.5-1
Covenant	3.2-2
Credentials	3.1-2
Cross-border	3.3-4
Cross-border service	5.3-1
Currency conversion and remittance	4.7-1
Customs duties and taxes article	2.2-3

D

Damp lease	4.7-6
Damp-leased aircraft	5.2-2
<i>De facto</i>	3.2-3
<i>De jure</i>	3.2-3
<i>De minimis</i>	3.2-3
Decision 297 of the Commission on the Cartagena Accord	3.2-6
Declaration	3.2-2
Definition of a scheduled international air service	3.4-4
Definitions article	2.2-2
Delegation	2.1-3
Denunciation	2.1-8
Denunciation article	2.2-4
Denunciation of a treaty	3.1-4
Depository	3.1-4
Designated carrier	5.1-1
Designation	4.1-2
Designation and authorization article	2.2-2
DG IV (Competition)	3.7-4
DG VII (Transport)	3.7-4
DG XI (Environment, Consumer Protection and Nuclear Safety)	3.7-4

Digest of Bilateral Air Transport Agreements

(Doc 9511)	3.4-4
Diplomatic conference	3.1-3
Diplomatic note	2.1-5
Direct air service	5.3-2
Direct transit traffic	4.1-11
Directorates-General (DG)	3.7-4
Discount ticket	4.3-5
Discounted fare	4.3-5
Dispute resolution consultation	2.1-2
Divisional session	3.4-2
Doing business rights	2.2-3
Domestic air service	5.3-1
Domestic airport	5.4-1
Domestic carrier	5.1-1
Domestic tariff	4.3-2
Domestic traffic	4.3-2
Double approval	4.3-6
Double disapproval	4.3-6
Double track route	4.1-4
Double tracking	4.1-4
Drafting group	2.1-4
Dry lease	4.7-5
Dry-leased aircraft	5.2-2
Dual designation	4.1-5
Dual disapproval	4.3-6

E

East Asian Economic Caucus (EAEC)	3.7-2
ECAC Coordinating Committee	3.6-1
ECAC Meetings of Directors General of Civil Aviation (DGCA)	3.6-1
ECAC Plenary Conference	3.6-1
ECAC policy statements	3.6-2
ECAC resolutions	3.6-2
Economic and Monetary Union (EMU)	3.7-4
Economic and Social Commission for Asia and the Pacific (ESCAP)	3.7-2
Economic and Social Commission for Western Asia (ESCWA)	3.7-6
Economic and Social Committee (ECS)	3.7-4
Economic Commission	3.4-1
Economic Commission for Africa (ECA)	3.7-1
Economic Commission for Europe (ECE)	3.7-3
Economic Commission for Latin America and the Caribbean (ECLAC)	3.7-5
Economic Community of Central African States (ECCAS)	3.7-1
Economic Community of the Great Lakes Countries (CEPGL)	3.7-1

Economic Community of West African States (ECOWAS)	3.7-2	Fare agreement	4.3-3
Economic Cooperation Organization (ECO)	3.7-6	Fare-band system	4.3-7
Effective date	4.3-8	Federation of Air Transport User Representatives in Europe (FATURE)	3.9-2
Effective regulatory control	4.4-5	Federation of Air Transport User Representatives in the European Community	3.9-2
Effective tariff	4.3-8	Feeder carrier	5.1-2
Eighth Freedom of the Air	4.1-10	Feeder service	5.3-2
Eighth Freedom Right	4.1-10	Ferry flight	4.1-6
Electronic commerce (e-commerce)	4.7-4	Fifth Freedom of the Air	4.1-8
Electronic Data Interchange for Administration, Commerce and Transport (EDIFACT)	3.8-4	Fifth Freedom Right	4.1-8
Electronic tariff filing system	4.3-8	Final act	3.1-3
Electronic ticketing (e-ticketing)	4.7-5	Financial lease	4.7-5
Enplaning traffic	4.1-11	First Freedom of the Air	4.1-5
Entry into force article	2.2-4	First Freedom Right	4.1-5
Established tariff	4.3-8	First person note	2.1-5
ETOPS	5.2-2	Five Freedoms Agreement	3.2-4
European Airlines Research Bureau (EARB)	3.9-2	Fixed-wing aircraft	5.2-1
European Atomic Energy Community (EAEC or EURATOM)	3.7-3	Flag carrier	5.1-1
European Central Bank	3.7-4	Flags of convenience	4.4-4
European Civil Aviation Conference (ECAC)	3.6-1	Flexible pricing zones	4.3-6
European Coal and Steel Community (ECSC)	3.7-3	Flight sector	4.1-12
European Commission	3.7-4	Flight stage(s)	4.1-12
European Communities	3.7-3	Flimsy	3.1-2
European Community (EC)	3.7-3	Foreign investment	4.1-2
European Court of Auditors (ECA)	3.7-4	Formal consultation	2.1-1
European Court of Justice (ECJ)	3.7-4	Formal note	2.1-5
European Economic Area (EEA)	3.7-3	Fortaleza Agreement	3.2-6
European Economic Community (EEC)	3.7-3	Fourth Freedom of the Air	4.1-8
European Free Trade Association (EFTA)	3.7-4	Fourth Freedom Right	4.1-8
European Parliament (EP)	3.7-4	Framework Agreement	2.1-6
European Regions Airlines Association (ERA)	3.9-2	Franchise	4.1-7
European Union (EU)	3.7-3	Franchisee	4.1-7
Evaluating tariffs	4.3-7	Franchiser	4.1-7
<i>Ex parte</i>	3.2-3	Franchising	4.1-7
<i>Ex post facto</i>	3.2-3	Free pricing	4.3-6
Exchange of letters	2.2-4	Free riders	3.3-5
Excursion fare	4.3-4	Free-determination method	4.2-2
Expanding bilateral	2.4-1	Freight	4.5-1
Expert group	2.1-4	Freight consolidators/forwarders	4.5-2
Expiry dates	4.3-8	Freight-all-kinds rate	4.3-5
Express/small package business	4.5-1	Freighter	5.2-1
Extension consultation	2.1-2	Frequent flyer programmes	4.3-2
Extra section flight	4.1-6	Full Powers	2.1-7
		Full-service carrier	5.1-2
F		G	
Fair and equal opportunity article	2.2-2	Gateway	4.1-4
Fair competition article	2.2-3	Gateway airport	5.4-1
“Fan” change of gauge	4.1-6	Gateway point	4.1-4
Fare	4.3-2	GATS Annex on Air Transport Services	3.3-4

- GATS core liberalization principles 3.3-5
- GATS general obligation 3.3-5
- Gazette 1.2-3
- General Agreement on Tariffs and Trade (GATT) . . . 3.5-2
- General Agreement on Trade in Services (GATS) . . . 3.3-4
- General cargo rate 4.3-5
- General rules 4.3-2
- Geneva Convention 3.2-5
- Global distribution systems (GDSs) 4.7-4
- Global market 4.1-1
- Good offices 2.1-8
- Governing body 3.2-2
- Government order fare 4.3-3
- Grand cabotage 4.1-10
- Grandfather rights 4.10-2
- Grant of rights article 2.2-2
- Gross fare 4.3-4
- Ground handling 4.10-1
- Group inclusive tour fare (GIT fare) 4.3-4
- Group of Eight (G-8) 3.7-6
- Group of Negotiations on Services (GNS) 3.3-4
- Group of Seven (G-7) 3.7-6
- Group of Seventy Seven (G-77) 3.7-6
- Guadalajara Convention 3.2-4
- Guatemala City Protocol 3.2-4
- Gulf Cooperation Council 3.7-5
- H**
- Hard rights 2.2-3
- Havana Convention 3.0-2
- Helicopter 5.2-1
- Heliport 5.4-1
- High-capacity aircraft 5.2-2
- High-speed civil transport aircraft (HSCT) 5.2-2
- Historical precedence 4.10-2
- Hovercraft (HOV) 4.1-8
- Hub 5.4-2
- Hub airport 5.4-2
- Hub-and-spoke system 5.4-2
- Hubbing 5.4-2
- Hypersonic aircraft 5.2-2
- I**
- IATA Annual General Meeting (AGM) 3.8-1
- IATA Board of Governors (BG) 3.8-1
- IATA Cargo Agency Conference (CAConf) 3.8-2
- IATA Cargo Services Conference (CSC) 3.8-2
- IATA Cargo Tariff Coordinating Conferences
(CTCs) 3.8-2
- IATA carrier 5.1-2
- IATA currency conversion system A2-1
- IATA fare 4.3-3
- IATA Industry Affairs Committee (IAC) 3.8-1
- IATA interlining 4.3-9
- IATA Passenger Agency Conference (PACConf) 3.8-2
- IATA Passenger Services Conference (PSC) 3.8-2
- IATA Passenger Tariff Coordinating Conferences
(PTCs) 3.8-2
- IATA Procedures Conference 3.8-2
- IATA Schedules Conference 3.8-4
- IATA Secretariat 3.8-1
- IATA Special Committees 3.8-1
- IATA standard premium service fares
(SPS fares) 4.3-10
- IATA Standing Committees 3.8-1
- IATA Tariff Coordinating Conference (TC) 3.8-2
- IATA tariff coordination process 3.8-2
- IATA Traffic Conference 3.8-1
- IATA/SITA baggage tracing (BAGTRAC) system . . . 3.8-4
- Ibero-American Convention Relating to
Air Navigation 3.0-2
- ICAO circular 3.4-5
- ICAO digest of statistics 3.4-5
- ICAO document 3.4-4
- ICAO Journal 3.4-4
- ICAO regional workshops 3.4-5
- ICAO Regional Workshops on Air Transport
Regulatory Policy 3.4-5
- ICAO Regulatory Policy Seminar 3.4-5
- ICAO Secretariat 3.4-1
- ICAO State Letter 3.4-5
- ICAO's Policies on Charges for Airports and
Air Navigation Services* (Doc 9082) 3.4-4
- ICAO's Policies on Taxation in the Field of
International Air Transport* (Doc 8632) 3.4-4
- Improperly documented passengers 4.9-6
- Inadmissible persons 4.9-6
- Inclusive tour charter (ITC) 4.6-2
- Increasing participation of developing countries . . . 3.3-5
- Indian Ocean Commission (IOC) 3.7-2
- Individual inclusive tour fare (IIT fare) 4.3-4
- Informal consultation 2.1-1
- Information paper 3.1-2
- Innovation consultation 2.1-2
- Instant purchase fare 4.3-4
- Institut du Droit International (IDI) 3.9-3
- Institut du Transport Aérien (ITA) 3.9-3
- Instruments of ratification, acceptance
or approval 3.1-4
- Inter alia* 3.2-3
- Inter se* agreement 3.1-4
- Interchange flight 4.1-8

- Intergovernmental Agreement on Civil Aviation and Airspace Use 3.6-2
- Intergovernmental organization 3.2-1
- Interim Agreement on International Civil Aviation . . 3.0-2
- Interim Commission of the International Trade Organization 3.5-2
- Interline connecting traffic 4.1-12
- Interline electronic ticketing (e-interlining) 4.7-5
- Interline fare 4.3-3
- Interline hub 5.4-2
- Interline stopover traffic 4.1-10
- Interlining 4.3-3
- Intermediate point 4.1-3
- Intermingling 4.6-2
- Intermodal hub 5.4-2
- Intermodal rate 4.3-5
- Intermodal right 4.1-8
- Intermodal transport 4.5-1
- International Agreement on the Procedure for the Establishment of Tariffs for Intra-European Scheduled Air Services 3.2-6
- International Agreement on the Procedure for the Establishment of Tariffs for Scheduled Air Services 3.2-5
- International Agreement on the Sharing of Capacity on Intra-European Scheduled Air Services 3.2-6
- International Air Carrier Association (IACA) 3.9-2
- International air service 5.3-1
- International Air Services Transit Agreement 3.2-4
- International Air Transport Agreement 3.2-4
- International Air Transport Association (IATA) 3.8-1
- International airport 5.4-1
- International Bank for Reconstruction and Development (IBRD) 3.5.2
- International Business Aviation Council (IBAC) 3.9-2
- International Business Travel Association (IBTA) 3.9-3
- International carrier 5.1-1
- International Chamber of Commerce (ICC) 3.9-3
- International Civil Airports Association (ICAA) 3.9-2
- International Civil Aviation Organization (ICAO) 3.4-1
- International Commission on Air Navigation (ICAN) 3.0-2
- International Conference of Air Navigation 3.0-2
- International Council of Aircraft Owner and Pilot Associations (IAOPA) 3.9-2
- International Court of Justice (ICJ) 3.5-1
- International Federation of Air Line Pilots' Associations (IFALPA) 3.9-2
- International Federation of Forwarding Organizations 3.9-3
- International Federation of Freight Forwarders Associations (FIATA) 3.9-3
- International Federation of Ship, Dock and River Workers 3.9-3
- International Federation of Tour Operators (IFTO) 3.9-3
- International Foundation of Airline Passengers' Association (IFAPA) 3.9-3
- International Labour Organization (ILO) 3.5-2
- International Law Association (ILA) 3.9-3
- International organization 3.2-1
- International Organization for Standardization (ISO) 3.5-2
- International Organization of Consumers Unions (IOCU) 3.9-2
- International tariff 4.3-2
- International Telecommunication Union (ITU) 3.5-2
- International Trade Organization (ITO) 3.5-2
- International Transport Workers' Federation (ITF) 3.9-3
- International Union of American Republics 3.7-6
- Internet fare 4.3-5
- Interstate Aviation Committee (IAC) 3.6-2
- Intervention 3.1-3
- Inventory control 4.2-5
- Inward investment 4.1-2
- Issuing carrier 4.3-9
- J**
- Jet aircraft 5.2-2
- Joint Aviation Authorities (JAA) 3.6-2
- Joint bilateral negotiation 2.4-1
- Joint fare 4.3-3
- Joint service flight 4.1-1
- Joint venture carrier 5.1-2
- Journal 1.2-3
- Jumbo jet 5.2-1
- Just in time 4.5-1
- Justice and Home Affairs (JHA) 3.7-3
- K**
- Kona Agreement 3.2-6
- L**
- LACAC Assembly 3.6-2
- LACAC Executive Committee 3.6-2
- LACAC Group of Experts on Air Transport Policies (GEPTA) 3.6-2
- LACAC Group of Experts on Costs and Tariffs (GECOT) 3.6-2
- Large aircraft 5.2-1

Latin American Civil Aviation Commission (LACAC)	3.6-2
Latin American Economic System (SELA)	3.7-5
Latin American Integration Association (LAIA)	3.7-5
Launch (LCH)	4.1-8
League of Arab States	3.6-2
League of Arab States (LAS)	3.7-6
Leased aircraft	5.2-2
Lessee	4.7-6
Lessee	5.2-2
Lessor	4.7-6
Lessor	5.2-2
Liberalized air agreements	2.2-2
Licence	1.1-1
Licensed carrier	5.1-1
Light aircraft	5.2-1
Limousine (LMO)	4.1-8
Load factor	4.2-1
Local fare	4.3-3
Local traffic	4.1-?
Lomé Convention	3.7-6
Long-range aircraft	5.2-2
Long-run marginal cost	4.3-11
Low-cost carrier	5.1-2
Lowest combination principle	4.3-3

M

Maastricht Treaty	3.7-3
Madrid Convention	3.0-2
Mail hub	5.4-2
Major air carrier	5.1-2
Major hub	5.4-2
<i>Mala fide</i>	3.2-3
Mandatory stop requirement	4.1-6
<i>Manual on Air Traffic Forecasting</i> (Doc 8991)	3.4-4
<i>Manual on Air Navigation Services Economics</i> (Doc 9161)	3.4-4
<i>Manual on the ICAO Statistics Programme</i> (Doc 9060)	3.4-4
Market access	3.3-5
Market fare	4.3-2
Marketing	4.7-2
Matching tariffs	4.3-7
Maximum permitted mileage (MPM)	4.3-3
Maximum tariff system	4.3-8
Mean load factor	4.2-1
Mediation	2.1-8
Medium-range aircraft	5.2-2
Mega-alliances	4.8-1
Mega-carrier	5.1-2
Mega-hub	5.4-2

Memorandum of consultation	2.1-5
Memorandum of Understanding (MOU)	2.2-1
Mercosur Treaty	3.7-5
Mileage fare	4.3-3
Mileage principle	4.3-3
Mini-hub	5.4-2
Minutes	3.1-3
Mixed passenger/cargo charter	4.6-2
Model bilateral air transport agreement	2.1-3
Modes of supply	3.3-4
Modification consultation	2.1-2
Modification to a treaty	3.1-4
Montevideo Treaty	3.7-5
Montreal Agreement of 1966	3.2-4
Montreal Convention	3.2-5
Montreal Convention of 1999	3.2-5
Montreal Protocol No. 4	3.2-4
Most-favoured nation (MFN) treatment	3.3-5
Multilateral agreement article	2.2-4
Multilateral Agreement Concerning the Operation of Air Services within the Caribbean Community (CARICOM)	3.2-6
Multilateral Agreement on Commercial Rights of Non-scheduled Air Services among the Association of South-East Asian Nations (ASEAN)	3.2-5
Multilateral Agreement on Commercial Rights of Non-scheduled Air Services in Europe	3.2-5
Multilateral Agreement on the Liberalization of International Air Transportation	3.2-6
Multilateral Air Services Agreement for Liberalization among States of the Pacific Islands Forum	3.2-6
Multilateral Interline Traffic Agreement (MITA)	3.8-4
Multilateral Prorate Agreement (MPA)	4.3-9
Multilateral regulation	3.0-1
Multi-modal hub	5.4-2
Multiple class seating	4.2-5
Multiple controlled designation	4.1-5
Multiple unlimited designation	4.1-5
<i>Mutatis mutandis</i>	3.2-3

N

Narrow-body aircraft	5.2-1
National carrier	5.1-1
National regulation of air transport	1.0-1
National treatment	3.3-5
Nationality of aircraft	5.2-1
Negotiated fares	4.3-4
Negotiating position	2.1-3
Negotiating round	2.1-4

Negotiating team 2.1-3
 Negotiating venue 2.1-3
 Negotiation 2.1-1
 Net fare 4.3-4
 Net/net 4.3-5
 Network carrier 5.1-2
 New entrant carrier 5.1-2
 Niche carrier 5.1-2
 Ninth Freedom of the Air 4.1-10
 Ninth Freedom Right 4.1-11
 No-frills carrier 5.1-2
 Non-affinity group charter 4.6-2
 Non-governmental organization (NGO) 3.2-1
 Non-IATA carrier 5.1-2
 Non-IATA fare 4.3-3
 Non-IATA interlining 4.3-9
 Non-national personnel 4.7-2
 Non-paper 2.1-5
 Non-promotional-type special fare 4.3-3
 Non-scheduled air service 4.6-1
 Non-scheduled Air Services Agreement 2.2-1
 Non-scheduled carrier 5.1-1
 Non-scheduled international carrier 5.1-1
 Non-scheduled international flight 5.3-2
 Non-stop service 5.3-2
 Nordic Council (NC) 3.7-4
 Normal fare 4.3-3
 North America Free Trade Agreement (NAFTA) 3.7-5
 Note 2.1-5
 Note verbale 2.1-5

O

Offers and requests 3.3-6
 Off-line 4.7-3
 Off-tariff fare 4.3-2
 Oneworld 4.8-1
 Online 4.7-3
 Online connecting traffic 4.1-12
 Online fare 4.3-3
 Online hub 5.4-2
 Online stopover traffic 4.1-12
 Open area 3.8-3
 Open Skies Agreement 2.2-2
 Operating lease 4.7-5
 Operational right 4.1-6
 Operator 4.7-6
 Optional stop right 4.1-?
 Order of business 3.1-2
 Organisation for Economic Cooperation and
 Development (OECD) 3.5-3

Organization of African Unity (OAU) 3.7-2
 Organization of American States (OAS) 3.7-6
 Organization of Central American States (OCAS) 3.7-5
 Organization of Eastern Caribbean States (OECS) 3.7-5
 Orient Airlines Association (OAA) 3.9-1
 Orient Airlines Research Bureau 3.9-1
 Originating traffic 4.1-11
 Overbooking 4.2-5
 Overflight right 4.1-5
 Own-use charter 4.6-2

P

Pacific Asia Travel Association (PATA) 3.9-3
 Pacific Community 3.7-3
 Package 3.8-3
Pacta sunt servanda 3.1-4
 Pallets 4.5-1
 Pan-American Convention on Commercial Aviation 3.0-2
 Pan-American Union 3.7-6
 Panel 3.4-2
 Panel on Air Navigation Services Economics 3.4-2
 Paris Club 3.7-6
 Paris Convention 3.0-2
 Paris Convention for the Regulation of Aerial
 Navigation 3.0-2
 Parliamentary Assembly of the Council of Europe 3.7-3
 Part charter 4.6-3
 Partial blind sector 4.1-10
 Participation measures 2.3-8
 Parties 2.2-2
 Passenger air carrier 5.1-1
 Passenger air service 5.3-1
 Passenger aircraft 5.2-1
 Passenger load factor 4.2-1
 Passenger rights 4.9-1
 Passenger throughput 5.4-1
 Passenger ticket 4.3-2
 Passenger tonne-kilometres performed 5.1-3
 Peak load pricing 4.3-4
Per se 3.2-3
 Permanent Secretariat of the General Treaty
 on Central American Economic Integration
 (SIECA) 3.7-5
 Permit 1.1-1
 Petit cabotage 4.1-10
 PEX fare 4.3-4
 Piston-engine aircraft 5.2-2
 Plenary 2.1-4
 Plurilateral agreement 2.4-1
 Point 4.1-2
 Point-to-point normal fare 4.3-3

Policy and Guidance Material on the Economic

<i>Regulation of International Air Transport</i> (Doc 9587)	3.4-4
Pooling arrangements	4.2-6
Position paper	2.1-3
Positioning flight	4.1-6
Postal hub	5.4-2
Preamble	2.2-2
Preambular clauses	3.2-2
Precedence	2.1-7
Preclearance agreement	2.2-4
Predatory tariff	4.3-7
Predetermination method	4.2-2
Preferential measures	2.3-8
Preferential Trade Area for Eastern and Southern African States (PTA)	3.7-2
Presence of a natural person	3.3-5
Price leadership	4.3-7
<i>Prima facie</i>	3.2-3
Principal place of business	4.4-5
Principals' meeting	2.1-4
Private aircraft	5.2-1
Private airport	5.4-1
Private carrier	5.1-2
Private fare	4.3-2
Private involvement	4.10-4
Private participation	4.10-4
Privatization	4.10-4
Process of bilateral regulation	2.1-1
Process of multilateral regulation	3.1-1
Process of national regulation	1.1-1
Programmed charters	4.6-4
Progressive liberalization	4.1-2
Promotional-type special fare	4.3-4
Proportional fare	4.3-3
Proportionate action	2.1-8
Proposed tariff	4.3-8
"Prorating" revenues	A3-1
Protocol	2.2-4
Protocol Supplementary to the Montreal Convention of 1971	3.2-5
Protocol to the Multilateral Agreement on the Liberalization of International Air Transportation	3.2-6
Provisional agenda	3.1-2
Provisional International Civil Aviation Organization (PICAO)	3.0-2
Provisional order of business	3.1-2
Public charter	4.6-2
Public excursion fare	4.3-4
Public fare	4.3-2
Published fare	4.3-2

Q

Quorum	3.1-2
------------------	-------

R

Rapporteur	3.1-2
Rate	4.3-2
Ratification	2.1-7
Reciprocity	1.1-3
Recommendation	3.2-2
Redistribution consultation	2.1-2
Reference levels	4.3-7
Regional air service	5.3-1
Regional aircraft	5.2-2
Regional airport	5.4-1
Regional carrier	5.1-2
Regional hub	5.4-2
Regional jet	5.2-2
Region-to-region market	4.1-1
Register	1.2-3
Registration article	2.2-4
Regulation	(iii)
Regulatory content	(iii)
<i>Regulatory Implications of the Allocation of Flight Departure and Arrival Slots at International Airports (Cir 283)</i>	3.4-4
Regulatory process	(iii)
Regulatory structure	(iii)
Reliever airports	5.4-1
Reservation	3.1-4
Resolution	3.2-2
Resolution documents (Res. Docs.)	3.8-3
Resolutions	3.8-3
Resolving clause(s)	3.2-2
Restricted normal fare	4.3-3
Revenue management	4.2-5
Revenue passenger	5.1-3
Revenue passenger-kilometres (RPKs)	5.1-3
Revenue tonne-kilometre (RTK)	5.1-3
Revocation of operating authorization article	2.2-3
Right of establishment	4.1-2
Right of optional omission of stops	4.1-6
Right of overflight	4.1-5
Right of technical stop	4.1-5
Right to operate extra section flights	4.1-6
Rome Convention	3.2-5
Rome Treaties	3.7-3
Rotary-wing aircraft	5.2-1
Round	2.1-4
Round of consultations	2.1-4

Round of negotiations 2.1-4
 Route annex 2.2-4
 Route right 4.1-2
 Route schedule(s) 2.2-4
 Route terminal 4.1-4
 Routing fare 4.3-3
 Rover point 4.1-3
 Rule-of-reason approach 4.3-11
 Runway capacity 5.4-1

S

Safety article 2.2-3
 Safety net 4.1-2
 Scheduled air carrier 5.1-1
 Scheduled air service 5.3-1
 Scheduled airline 5.1-1
 Scheduled international air service 5.3-1
 Scheduled international carrier 5.1-1
 Scheduling season 4.10-2
 Schedulized charters 4.6-4
 Seasonalities 4.3-4
 Seat factor 4.2-1
 Seat-kilometres available 5.1-3
 Second country hub 5.4-2
 Second Freedom of the Air 4.1-5
 Second Freedom Right 4.1-5
 Second section flight 4.1-6
 Second-country change of gauge 4.1-6
 Secretariat 3.2-1
 Secretariat study group 3.4-3
 Selling and marketing of air transport services 3.3-4
 Selling date 4.3.8
 Selling fare 4.3-5
 Sell-up tariff structure 4.3-4
 Settlement of disputes article 2.2-4
 Seventh Freedom of the Air 4.1-10
 Short-notice filing 4.3-8
 Short-range aircraft 5.2-2
 Short-run marginal cost 4.3-11
 Shuttle air service 5.3-2
 Signature provisions 2.2-4
 Single class seating 4.2-5
 Single designation 4.1-5
 Single disapproval regime 4.3-7
 Single entity charter 4.6-2
 Single European Market 3.7-4
 Single track route 4.1-5
 Single tracking 4.1-5
 Single-factor fare 4.3-3
 Sixth Freedom of the Air 4.1-10

Sixth Freedom Right 4.1-10
 Sky Team 4.8-1
 Slot allocation mechanism 4.10-2
 Slots 3.8-4
 Small aircraft 5.2-1
 Société Internationale de Télécommunications
 Aéronautiques (SITA) 3.9-3
 Soft rights 2.2-3
 South Asian Association for Regional
 Cooperation (SAARC) 3.7-3
 South Pacific Bureau for Economic Cooperation
 (SPEC) 3.7-3
 South Pacific Commission (SPC) 3.7-3
 South Pacific Forum 3.7-3
 Southern Africa Transport and Communications
 Commission (SATCC) 3.7-2
 Southern African Development Community
 (SADC) 3.7-2
 Southern African Development Coordination
 Conference (SADCC) 3.7-2
 Southern Cone Common Market (MERCOSUR) 3.7-5
 Sovereign body 3.2-1
 Special Drawing Rights (SDR) 3.2-4
 Special event charter 4.6-2
 Special excursion fare 4.3-4
 Special fare 4.3-3
 Special Prorate Agreement (SPA) 4.3-9
 Specific commodity rate 4.3-5
 Specific principles under the GATS 3.3-5
 Specific rules 4.3-2
 Specified fare 4.3-3
 Split charter 4.6-2
 Stage 2 aircraft 5.2-3
 Stage 3 aircraft 5.2-3
 “Stand alone” cabotage 4.1-?
 Standard commissions 4.3-2
 Standby lists 4.2-6
 STAR Alliance 4.8-1
 Starting net 4.3-4
 Start-up carrier 5.1-2
 State aircraft 5.2-1
 State of Registry 4.7-6
 State of the Operator 4.7-6
 State-owned carrier 5.1-2
 Statistics article 2.2-3
 Status fare 4.3-3
Status quo 3.2-3
Status quo ante 3.2-3
 Statutory-notice filing 4.3-8
 Stockholm Convention 3.7-4
 STOL aircraft 5.2-1
 Stolport 5.4-1

Stopover	4.1-11
Stopover traffic	4.1-11
Structure of bilateral regulation	2.2-1
Structure of multilateral regulation	3.2-1
Structure of national regulation	1.2-1
Student charter	4.6-2
Study Group on Computer Reservation Systems (CRS)	3.4-3
Sub-Area Conferences	3.8-2
Subsonic aircraft	5.2-2
Succession to a bilateral agreement	2.1-7
Sum of sectors	4.3-7
<i>Suo moto</i>	3.2-3
Super-hub	5.4-2
Supersonic aircraft	5.2-2
Supplemental airports	5.4-1
Supra-State	2.0-1
Surface conveyances	4.1-8
Suspension of operating authorization article	2.2-3

T

Tariff	4.3-1
Tariff article	2.2-3
Tariff condition	4.3-2
Tariff consultation	4.3-9
Tariff coordination	4.3-9
Tariff enforcement	4.3-5
Tariff filing	4.3-1
Tariff malpractice	4.3-5
Tariff rule	4.3-2
Taxation article	2.2-3
TC member	3.8-2
Technical stop right	4.1-5
Template air services agreements (TSAs)	2.2-2
Terminal capacity	5.4-1
Terminal point	4.1-4
Termination article	2.2-4
Terms of reference	3.2-2
The Hague Convention	3.2-5
The Hague Protocol	3.2-4
Third Freedom of the Air	4.1-8
Third Freedom Right	4.1-8
Third person note	2.1-5
Third-country change of gauge	4.1-6
Through fare	4.3-3
Through service	5.3-2
Ticket or waybill origin and destination	4.1-10
Ticketed point mileage (TPM)	4.3-3
Tokyo Convention	3.2-5
Tonne-kilometres available	5.1-3

Tonne-kilometres performed (TKPs)	5.1-3
Tour operator	4.6-2
Traffic right	4.1-8
Traffic rights	4.1-8
Train (TRN)	4.1-8
Transborder tariff	4.3-2
Transit traffic	4.1-12
Transparency	3.3-5
Transport aircraft	5.2-1
Trans-regional	3.2-1
Treaty	3.2-2
Treaty of Chaguaramas	3.7-5
Treaty of Izmir	3.7-6
Treaty on European Union	3.7-3
Tri-jet	5.2-2
Truck/road feeder service (RFS)	4.1-8
True origin and destination	4.1-10
Trunk service	5.3-2
Turbofan aircraft	5.2-2
Turbojet aircraft	5.2-2
Turboprop aircraft	5.2-2
Twin jet	5.2-2
Two Freedoms Agreement	3.2-4

U

ULD (unit load device) discount rate	4.3-5
ULDs (unit load devices)	4.5-1
Ultra-high-capacity transport aircraft (UHCT)	5.2-2
Ultra-light aircraft	5.2-1
UN Economic and Social Council (ECOSOC)	3.5-1
UN General Assembly	3.5-1
UN regional commissions	3.5-1
UN Secretariat	3.5-1
UN Security Council	3.5-1
Unbundled fare	4.3-3
United Nations (UN)	3.5-1
United Nations Conference on Trade and Development (UNCTAD)	3.5-2
United Nations Framework Convention on Climate Change Secretariat (UNFCCC Secretariat)	3.5-3
United Nations Transport and Communications Decades	3.5-1
United Nations Treaty Series (UNTS)	3.5-1
Universal Federation of Travel Agents' Associations (UFTAA)	3.9-3
Universal Postal Union (UPU)	3.5-2
Unpublished fare	4.3-2
Unruly or disruptive passengers	4.9-5
Uruguay Round	3.5-2
User charges article	2.2-3

V

Very large commercial transport aircraft (VLCT) . . . 5.2-2
Vienna Convention on the Law of Treaties 3.2-2
Visit another country tariff 4.3-2
Voluntary commitments 4.9-1

W

Warsaw Convention 3.2-4
Warsaw System 3.2-4
Waves 5.4-2
Web fare 4.3-5
West African Economic Community (CEAO) 3.7-2
Wet lease 4.7-6
Wet-leased aircraft 5.2-2
White Paper 1.2-3
Wide-body aircraft 5.2-1
Withdrawal from a treaty 3.1-4
Wholesaler 4.3-4

Working group 2.1-4
Working paper 3.1-2
World Bank Group 3.5-2
World Tourism Organization (WTO-OMT) 3.5-2
World Trade Organization (WTO-OMC) 3.5-2
World Travel and Tourism Council (WTTC) 3.9-3

Y

“Y” change of gauge 4.1-6
Yamoussoukro Declaration on a New African
Air Transport Policy 3.2-6
Yield management 4.2-5

Z

Zemun Agreement of 1937 3.0-2
Zone fare systems 4.3-7
Zones of flexibility 4.3-7
Zones of reasonableness 4.3-7

— END —

© ICAO 2004
9/04, E/P1/300
11/04, E/P2/1300

Order No. 9626
Printed in ICAO

