

The Risks of Not Following Manufacturer's Instructions for Use and Recommended Practices

Martha Young, BS, MS, CSPDT

July 2012



Objectives

After completion of this self-study activity, the learner will be able to:

1. Explain the importance of following recommended practices and standards and manufacturer's instruction for use (IFU) to reduce the risk of infections and improve patient outcomes.
2. Update policies and procedures to ensure the correct biological indicator (BI), biological indicator process challenge device (BI PCD), and Class 6 emulating indicator is being used for the cycles being tested.
3. Update policies and procedures to ensure the steam sterilization process is routinely monitored with a BI at least weekly, preferably every day, and the advantages of monitoring each load.
4. Update policies and procedures to ensure loaner instruments with containment devices and rigid sterilization containers are cleaned properly.
5. Update policies and procedures to ensure double peel pouching is performed correctly.

Test Questions

- 1 **Patients are being put at risk when recommended practices and standards and manufacturer's instructions for use are not followed.**
A. True B. False
- 2 **Follow the BI and BI PCD manufacturer's IFUs to ensure the correct BI and BI PCD is used to monitor the correct steam sterilization cycle.**
A. True B. False
- 3 **When rigid sterilization containers are used for immediate-use steam sterilization, the correct BI PCD used for routine monitoring is a BI placed inside of the rigid sterilization container.**
A. True B. False
- 4 **A Class 6 emulating indicator or a Class 6 emulating indicator PCD labeled for a 270°F/132°C dynamic-air removal, 4 minute cycle can be used to monitor all 270°F/132°C dynamic-air removal cycles.**
A. True B. False
- 5 **For automated cleaning of loaner instruments with containment devices, the instrument trays, cases and lids must be cleaned separately, except for implants which may stay within the tray or caddy for reprocessing.**
A. True B. False
- 6 **The filter retention plates on the lids or bottoms of rigid sterilization containers do not have to be removed from the lid or bottom and loaded into the washer-disinfector separately.**
A. True B. False
- 7 **All brands of peel pouches can be used for double peel pouching.**
A. True B. False
- 8 **If you do not have a small enough peel pouch to fit inside the outer peel pouch then fold the inner peel pouch so it will fit.**
A. True B. False
- 9 **Do not write on the paper side of the peel pouch because this could damage the packaging by compromising the barrier properties of the material which could also cause the ink to bleed through to the instruments.**
A. True B. False
- 10 **If you have the ANSI/AAMI ST79:2006 *Comprehensive guide to steam sterilization and sterility assurance in health care facilities*, with or without the 2008 or 2009 amendments, then you should order the ANSI/AAMI ST79:2010 & A1:2010 & A2:2011 (Consolidated text) version.**
A. True B. False

Introduction

Risks are being taken daily in the reprocessing of reusable medical devices in sterile processing areas in hospitals, ambulatory surgery centers, clinics, and doctor and dental offices when recommended practices and standards and medical device manufacturers' instructions for use (IFUs) are not being followed. Taking risks can lead to surgical site infections, equipment cleaning and sterilization process failures, and unhappy staff because they do not have the equipment, tools, or time to properly clean and sterilize the medical devices, all of which has a financial impact on the cost of healthcare.

Some common reasons for not following the most up-to-date IFUs are because they do not arrive with purchased or loaned instruments when they enter the facility, and they may be difficult to find and access on corporate websites. For a fee, a company called Best Practice Professionals, Inc. (www.onesourcedocs.com, 1-800-701-3560) can assist you in obtaining IFUs.

Another problem is that some of the IFUs are difficult to follow and sometimes incomplete and even if you follow them the instruments may not be effectively cleaned. An example of this situation was part of a report from *iwatchnews.org* that stated "Filthy, dangerous medical implements have been showing up in hospitals and outpatient surgery centers with alarming regularity."¹ This report was the basis of a Today Show feature in February, 2012.

In October 2011 the Food and Drug Administration (FDA) and the Association for the Advancement of Medical Instrumentation (AAMI) held a Medical Device Reprocessing Summit at the FDA Headquarters in Silver Spring, MD. This meeting focused on critical issues related to the processing of medical devices and to identify, discuss, and formulate strategic initiatives and priorities to improve the safe reprocessing of reusable medical devices. A copy of the presentations and a report of this summit is available for free from AAMI.² The spring 2012 issue of the AAMI publication *Sterilization and Reprocessing – A Matter of*

Patient Safety is another good reference discussing cleaning and sterilization issues and it can be accessed free through AAMI.⁴

Instructions for Use were a major part of this discussion. One of the clarion themes of this meeting was for medical device manufacturers to "Pay early, iterative, and comprehensive attention to reprocessing requirements throughout the device design process."² When medical device manufacturers are designing medical devices and writing IFUs they need to understand and keep in mind the limitations of the equipment, tools, and time sterile processing personnel have to clean and sterilize medical devices.

Several suggestions were put forward at the meeting, including that healthcare facilities review a device's IFU before purchase to avoid complicated devices, and ensure that the facility has the equipment or supplies needed to process the device. This review would enable buyers to determine the time needed to process a clinician preferred device, and whether this processing can be completed in the time available between cases.² This information is also available in the ECRI *Top 10 Health Technology Hazards for 2012* document under Cross-contamination from flexible endoscopes but applies to all instruments.³

AAMI ST79 Section 7.2.2 states it is the responsibility of the device manufacturer to identify in their labeling (IFU) specific methods to ensure the device can be effectively cleaned and sterilized. "The written IFU of the device manufacturer should always be followed."⁷

If healthcare facilities do not follow the manufacturer's IFU the items may not be properly processed and the facility will take on more liability if the patient outcomes are not good. Recommended practices should be followed because they establish the state-of-the-art for sterile processing. Patient safety is the goal.

This inservice will discuss some of the risks the author sees being taken in health care facilities.

Biological indicators

Situation: A 1 hour and a 3 hour biological indicator (BI) is being used to monitor implant loads run in a 270°F/132°C vacuum-assisted steam sterilizer so the implant can be released in 1 hour.

Does that follow the manufacturer's instructions for use?

No. The IFUs say the 1 hour BI should be used in a 270°F/132°C, gravity-displacement steam sterilization cycle and the 3 hour BI should be used in 270°F/132°C vacuum-assisted or 250°F/121°C gravity steam sterilization cycles.^{5,6} The 1 hour BI is an inappropriate challenge for the 270°F/132°C vacuum-assisted steam sterilization cycle.

Does that follow recommended practices? No, because AAMI ST79 states in Section 10.5.3.1 that health care personnel should select BIs "that are suitable for use in the specific sterilization cycle (see the written IFU of the BI manufacturer and the sterilizer manufacturer)."⁷

What is the risk to the patient? The risk is the implant is being released without knowing whether the sterilization process was effective. AAMI ST79 in Section 10.6.3 states:

"The load should be quarantined until the results of the BI testing are available."

"Releasing implants before the BI results are known is unacceptable and should be the exception, not the rule."⁷

How to eliminate this risk? The Joint Commission (TJC) presentation at the annual International Association of Healthcare Central Service Materiel Management (IAHCSMM) meeting in April 2012 said TJC has been citing healthcare facilities for not using the correct BI for cycles being tested.⁸ This citing and the risk to the patient can be avoided if the BI IFUs and AAMI recommended practices are followed to ensure the correct BI is run for the steam sterilization cycle being tested.

Biological indicator process challenge devices (BI PCDs)

Situation: The Ambulatory Surgery Center is preparing a BI PCD by placing a 3 hour BI in an open, perforated, mesh bottom instrument tray for routine monitoring of the immediate-use steam sterilization process (IUSS) (see Figure 1) that is run at 270°F/132°C in a vacuum-assisted steam sterilization cycle but the rest of the day they process instruments in rigid sterilization containers (see Figure 2).

Figure 1. Biological indicator process challenge device for routine testing of immediate-use steam sterilization cycles in 270°F/132°C vacuum-assisted steam sterilizers using an open, perforated mesh bottom instrument tray



Figure 2. Rigid sterilization container used to routinely process instruments for immediate-use steam sterilization in 270°F/132°C vacuum-assisted steam sterilization cycles



Does that follow the manufacturer's instructions for use?

Yes and No. Yes, because the correct BI is being used for the cycle but no because the PCD is not representative of the load.⁶ The BI manufacturer's IFU says the BI should be placed in an appropriate test tray or package and if processing containers the BIs should be placed in the area determined to provide the greatest challenge to the sterilization process.⁶ In addition follow the manufacturer's IFU for placement of the BI in the load. Do not place another pack on top of the BI PCD because this will create too great of a challenge for air removal and steam penetration which could result in a positive BI.

Does that follow recommended practices? No, because AAMI ST79 states in Section 10.7.4.1:

*"A representative of the same type of tray to be routinely processed through the flash sterilizer should be selected to serve as the PCD (BI challenge test tray)."*⁷

Note: This section is being updated to say IUSS.

What is the risk to the patient? The risk is that a BI placed in an open, perforated, mesh bottom instrument tray is less of a challenge for air removal and steam penetration than a BI placed into a rigid sterilization container. This does not tell you that the items placed in rigid sterilization containers are being effectively sterilized in the IUSS cycle. AAMI ST79 states in Section 10.7.4.1 in the Rationale:

*"It is possible for the cycle to pass the open-tray test, indicating that the cycle parameters are adequate for microbial kill, yet fail when other configurations are used in the same sterilizer on the same day."*⁷

How to eliminate this risk? The Joint Commission (TJC) presentation at the annual IAHCSSM meeting in April 2012 said TJC has been citing healthcare facilities for not using the correct BI PCDs for cycles being tested.⁸ This citing and the risk to the patient can be avoided if the BI IFUs and AAMI recommended practices are followed to ensure the correct BI PCD is run for the specific sterilization cycle being tested.

The correct BI PCD to use at this healthcare facility would be a BI placed in a rigid sterilization container that is representative of the container used routinely (see Figure 3).

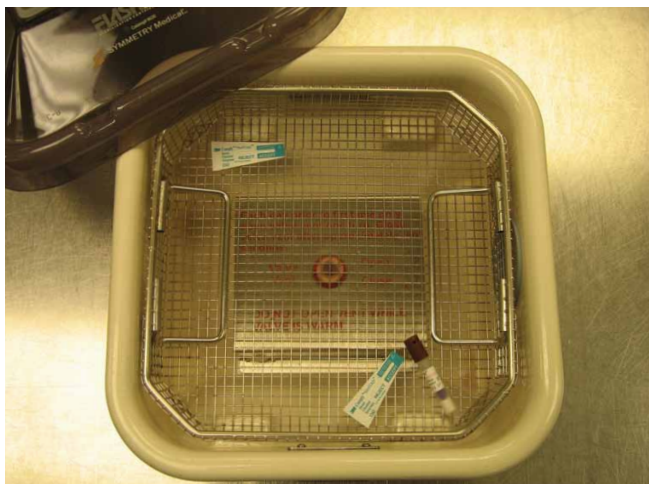

Figure 3. Biological indicator process challenge device for routine testing of immediate-use steam sterilization in 270°F/132°C vacuum-assisted steam sterilizers when rigid sterilization containers are used to routinely process instruments

Frequency of routine biological indicator testing

Situation: A health care facility was cited by TJC for not using a BI for routine testing at least weekly.⁸

Does that follow manufacturer's instructions for use?

It may, depending upon the BI being used. Recommendations vary from weekly to everyday to every load.

Does that follow recommended practices?

No. AAMI ST79 in Section 10.5.3 states:

*"Biological indicators should be used within PCDs (see 10.5.4, 10.7.2.1, 10.7.3.1, 10.7.4.1) for routine sterilizer efficacy monitoring at least weekly, but preferably every day that the sterilizer is in use (see 10.7)."*⁷

AAMI ST79 Section 10.7.1 also states that if a steam sterilizer is designed to be used for multiple types of cycles then:

- each type of cycle should be routinely tested because each cycle creates a different challenge to air removal and steam penetration
 - gravity-displacement at 132°C to 135°C [270°F to 275°F]
 - gravity-displacement at 121°C [250°F]
 - dynamic-air removal at 132°C to 135°C [270°F to 275°F]
 - flash at 132°C to 135°C [270°F to 275°F]
 - flash with single wrapper or other packaging.³

Note: This section is being updated to say immediate-use instead of flash.

A note states that if you are running both a 4 and a 10 minute dynamic-air removal sterilizer at 132°C to 135°C [270°F to 275°F], then only the shortest sterilization time needs to be tested.⁷

This means that in the same sterilizer if you were to run gravity-displacement cycles at 121°C [250°F] for 30 minutes and 1 hour, and dynamic-air-removal cycles at 132°C to 135°C [270°F to 275°F] for 4 and 10 minutes, that you only need to routinely challenge the 30-minute gravity-displacement cycle and the 4-minute

dynamic-air-removal cycle. This is because the shortest cycle time is the greatest challenge to air removal and steam penetration. Run the appropriate BI PCD at least weekly, but preferably every day that the sterilizer is in use.

The AAMI ST79 *Rationale* in Section 10.7.1 for this level of monitoring is that "Biological monitoring provides the only direct measure of the lethality of a sterilization cycle."⁷

What is the risk to the patient? The less frequently you routinely monitor each type of cycle used within a sterilizer, the greater the chance that one of the types of cycles run or an implant will not be tested or a sterilization process failure will go undetected which could result in poor patient outcomes.

How to eliminate this risk? TJC citing and the risk to the patient can be avoided if a BI PCD is used at least weekly, but preferably every day that the sterilizer is in use, in each type of sterilization cycle used in each sterilizer. Increasing your BI PCD monitoring to each load has the following advantages:

- Reducing the risk and cost of healthcare-associated infections (HAIs) because you know the load is not released until the BI is negative;
- Providing a universal standard of patient care by treating all loads the same with the equal chance of identifying a sterilization process failure before the patient becomes involved;
- Detects and controls variability in the process;
- Reducing the cost and impact of a recall;
- To be certain all implants, including those in loaners, are appropriately monitored and quarantined until the BI is negative;
- Ensure every type of steam sterilization cycle used is monitored; and
- Ensure every type of packaging used in immediate-use steam sterilization is monitored.

Chemical indicators (CI)

Situation: A Class 6 emulating indicator labeled for use in a 270°F/132°C dynamic-air removal, 4 minute cycle is being used as an internal chemical indicator inside each package for all cycles run in sterile processing (270°F/132°C dynamic-air removal for 4, 8, 10, and 30 minutes) and a CI PCD that is labeled for use in a 270°F/132°C dynamic-air removal, 4 minute cycle is being used to monitor all nonimplant cycles run in sterile processing (270°F/132°C dynamic-air removal for 4, 8, 10, and 30 minutes).

Does that follow manufacturer's instructions for use?

No. The Steris® Verify® SixCess® Chemical Indicator and Challenge Pack literature (document #M3500EN.2011-04, Rev A) says that the “product offering allows targeting of the specific sterilization cycle parameters you use.”⁹ The literature lists available challenge packs and strips and indicates which cycles they should be used to monitor. The Steris® Verify® SixCess™ Challenge Pack Selection and Interpretation Guide (document #M3130CA) states to “Select the challenge pack that matches your steam sterilization cycle.”¹⁰

Does that follow recommended practices?

No, because AAMI ST79 states in Section 10.5.2.2:

“An internal CI should be used within each package, tray, or rigid sterilization container system to be sterilized. This internal CI may be a single-variable (Class 3 CI), a multi-variable indicator (Class 4 CI), integrating indicator (Class 5 CI), or emulating indicator (Class 6 CI). It should be noted that Class 6 emulating indicators are cycle-specific; that is, they should be used only in the specific cycles for which they are labeled.”⁷

This information about using only Class 6 emulating indicators in the specific cycles for which they are labeled also applies to CI PCDs.

What is the risk to the patient? The risk is that if the Class 6 CI used is not FDA cleared and labeled for the cycle it is used to monitor, the CI will not provide an appropriate challenge for the sterilization process. The CI may show an effective sterilization process when it was not.

How to eliminate this risk? Run the Class 6 emulating CI and CI PCD in the cycles for which they are labeled according to the manufacturer's information and the recommended practices.

Cleaning of loaner instruments with containment devices

Situation: Because the loaner instruments arrived in sterile processing only 4 hours before they were to be used on a case the sterile processing personal placed the container of instruments directly into the washer-disinfector to save processing time (see Figure 4).

Figure 4. Loaner instrument containment devices improperly loaded into a washer-disinfector



Does that follow manufacturer's instructions for use?

Check the specific IFU, but in general instrument IFUs say that automatic cleaning using a washer/disinfector alone may not be effective for cleaning instruments with lumens, cannulations, blind holes, mated surfaces and other complex features and a thorough, manual or combination manual/automated cleaning process is recommended. The IFUs also, in general, say that instruments must be removed from metal or polymer trays for manual and/or automated cleaning procedures. Instrument trays, cases and lids must be cleaned separately. The exception to this rule is single-use plate and screw implants which may remain in the tray or caddy for reprocessing. This is to prevent them from being lost during the process because of their small size. The instruments need to be manually washed to clean lumens, crevices, mated surfaces, connectors, and other hard-to-clean areas.^{11,12} If the IFUs state the instruments must be removed from the tray when loading into the washer-disinfector this is to ensure all instruments come in contact with the cleaning agent and rinse water. If no information is provided in the IFU for loading instruments and cases into a washer-disinfector ask the manufacturer to provide that information in writing.

Does that follow recommended practices? AAMI ST79 states in Section 7.5.3.1:

“It is the responsibility of the manufacturer of the reusable device to provide written IFU for reprocessing in the labeling of the device (e.g., in the instruction manual). (See 7.2.2) These written IFU should recommend use of a particular type of cleaning equipment and/or a particular cleaning agent. Before health care personnel elect to use alternative equipment and/or cleaning agents, they should consult the device manufacturer and the manufacturer of the cleaning equipment or product.”⁷

What is the risk to the patient? The risk to the patient may be an infection if the instruments are not cleaned according to the IFU because without effective cleaning the instruments cannot be high-level disinfected or sterilized. Also, if the healthcare facility does not follow the IFU they now take on more liability if the patient outcomes are not good.

How to eliminate this risk? Set up the sterile processing department so they have the correct equipment, tools, quality monitors, time, and instructions for use to properly clean and sterilize medical devices. Put some teeth into your loaner policy by following the International Association of Healthcare Central Service Materiel Management Position Paper on the Management of Loaner Instrumentation and Sample Policy & Procedure for Loaner Instrumentation.¹³ IAHCMM suggests adopting such a loaner policy

and procedure to improve the processing of surgical instruments by requiring companies that provide loaner instruments to provide written instructions for use and to deliver the instruments to the facility's decontamination area at least:

- 2 working days (48 hours) before a scheduled case for existing sets; and
- 3 working days (72 hours) for new sets to allow inservicing, inspecting, and processing.¹³

Michele DeMeo, former manager of the sterile processing department (SPD) at Memorial Hospital in York, PA stated in OR Manager:

“Taking short cuts in preparing loaner instruments in time for surgery does not solve the problem of late delivery of loaner instruments and creates an even bigger problem related to patient safety and related costs that may be greater than the lost revenue. The SPD and OR manager need to ensure short cuts are not being made, collect data, and provide a solution to present to the administration to get their support for a loaner policy and procedure that ensures patients are provided with a properly processed set of instruments.”¹⁴

Just because you cannot relate taking risks by not following recommended practices and instructions to infections, does not mean there is no risk to the patient. There is no such thing as sterile dirt or debris. Even if an infection is not detected that does not mean the patient's surgical outcome is not affected by the presence of this dirt and debris.

Cleaning of rigid sterilization containers

Situation: Rigid sterilization containers are not taken apart for cleaning (see Figure 5)

Figure 5. Rigid sterilization containers incorrectly loaded into washer-disinfector



Does that follow manufacturer's instructions for use?

No. The IFUs for rigid sterilization containers say to disassemble the container into the following pieces for cleaning: lid, basket and instruments, and lid retention plate(s) from top and bottom, if applicable. Discard disposable filter and remove all processing indicators and disposable locks.^{15,16} Remove reusable filters and inspect according to the IFUs and replace if damaged or near recorded removal date. Place filters back inside retention plates.¹⁷ Disassembling all parts and loading correctly in the washer-disinfector will ensure that all surfaces are contacted by the cleaning agent and rinse water (see Figure 6 and 7).

Figure 6. Correct disassembly and loading of rigid sterilization container in washer-disinfector



Courtesy of Mark Duro, New England Baptist Hospital of Boston, MA

Does that follow recommended practices? AAMI ST9 states in Section 7.4.2:

- If container uses removable filters, remove the retention plates and discard the filter material.
- If container uses reusable filters, disassemble, clean, and replace according to the manufacturer's written IFU.
- For valve-type closures follow IFU for frequency and method of removal, disassembly and cleaning of bale-type closures.
- Remove inner basket and instruments from the container.⁷

Figure 7. Correct loading of basket and instruments from rigid sterilization container in washer-disinfector



Courtesy of Mark Duro, New England Baptist Hospital of Boston, MA

What is the risk to the patient? The risk to the patient may be an infection if the instruments and rigid sterilization containers are not cleaned according to the IFU, because without effective cleaning the instruments cannot be high-level disinfected or sterilized.

How to eliminate this risk? Follow the rigid sterilization container manufacturer's IFU and the recommended practices in AAMI ST9 for all the details on disassembly and loading of rigid sterilization containers and instruments in a washer-disinfector.

Double peel pouching

Situation: The inner peel pouch was folded over to fit into the outer peel pouch (see Figure 8).

Figure 8. Incorrect double peel pouching

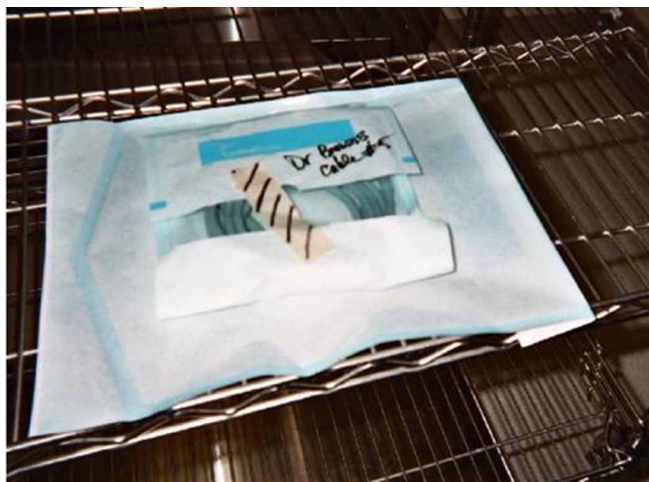

Courtesy of Steve Kovach and Ray Taurasi, Healthmark Industries Inc., Frazer, MI

Does that follow manufacturer's instructions for use? Check with the manufacturer of the peel pouch to see if the peel pouch had been validated for double peel pouching. Some brands have not been validated for double peel pouching.

Does that follow recommended practices? No. AAMI ST9 in Section 8.3.4 states in NOTE 2 not to double peel pouch unless you have documentation from the manufacturer "that the paper-plastic pouch has been validated for this use."⁷ In addition this Section states: "If the item is to be double-packaged, two sequentially sized pouches should be used (i.e., the sealed inner pouch should fit inside the other pouch without folding)."⁷

This means if the inner peel pouch is folded, compressed, or bent, air may be entrapped and the sterilant cannot penetrate. Position pouches so plastic faces plastic and paper faces paper (see Figure 8 from AAMI ST9).

AAMI Figure 8. Example of single- and double-packaging with paper-plastic pouches

NOTE: Instruments should be oriented within paper-plastic pouches according to the health care facility's policies and procedures.

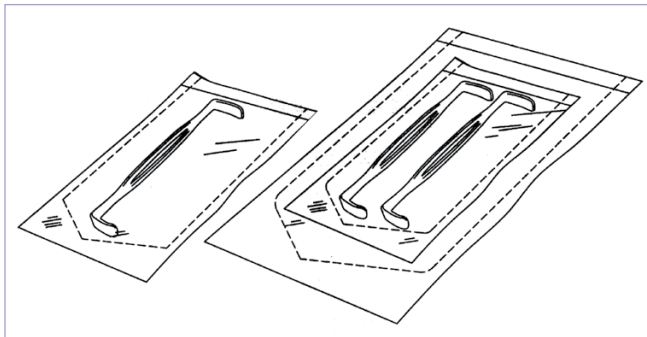

Reprinted from ANSI/AAMI ST79: ST79:2010 & A1:2010 & A2:2011 Comprehensive guide to steam sterilization and sterility assurance in health care facilities (Consolidated Text) with permission of the Association for the Advancement of Medical Instrumentation, Inc. © 2011 AAMI www.aami.org. All rights reserved. Further reproduction or distribution prohibited.

Peel pouches should be placed on their edge with the paper side facing one direction and the plastic side the other direction. Holding racks can be used for loading to ensure adequate sterilant contact and drying (see Figure 9 from AAMI ST79).⁷

AAMI Figure 9. Loading the sterilizer (e) Paper-plastic peel pouches (placed on edge)

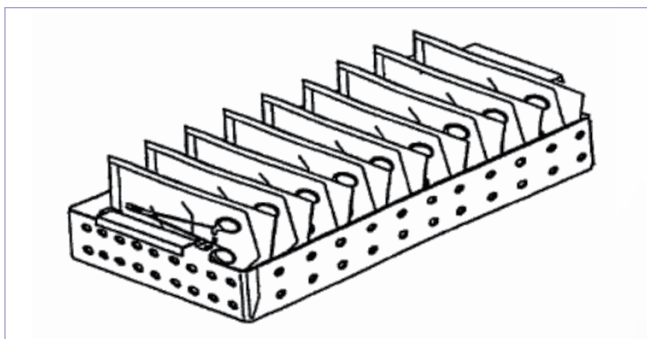

Reprinted from ANSI/AAMI ST79: ST79:2010 & A1:2010 & A2:2011 Comprehensive guide to steam sterilization and sterility assurance in health care facilities (Consolidated Text) with permission of the Association for the Advancement of Medical Instrumentation, Inc. © 2011 AAMI www.aami.org. All rights reserved. Further reproduction or distribution prohibited.

In addition:

- Do not place paper-plastic pouches within wrapped sets or containment devices;⁷
- Do not overload pouches because this can result in
 - Packaging seals breaking;
 - Wet pouches;
 - Ineffective sterilization because the sterilant cannot penetrate all the surfaces of the instruments;^{18,19}
- Do not write on the paper side because this could damage the packaging by compromising the barrier properties of the material which could also cause the ink to bleed through to the instruments;⁷
- Write on the plastic side with a permanent marker with nontoxic ink.⁷

What is the risk to the patient? The risk to the patient is that the instrument inside of the paper-plastic peel pouch will not be properly sterilized and will affect the outcome of the patient.

How to eliminate this risk? By following the paper-plastic peel pouch IFU and the recommended practices, the contents of the pouch can be effectively processed for patient care.

Summary

If you have discovered from reading this in-service that you are not using the correct BI, BI PCD, or Class 6 emulating indicator for the cycles being tested, or are incorrectly cleaning loaner instruments within containment devices or rigid sterilization container systems, or incorrectly using double peel pouches or peel pouches in general, then it is time to review your policies and procedures and update them to reflect the best practices based on recommended practices and standards and per the manufacturer's IFU. Patient safety depends on this and your job is to protect patients by correctly cleaning and packaging medical devices so they can be effectively sterilized.

Ordering Information

If you still have an ANSI/AAMI ST79:2006 recommended practices, with or without the 2008 and 2009 amendments, then you need to order the current version of ANSI/AAMI ST79 which will include the A2:2011 amendment. If you do not have the A2:2011 amendment it can be downloaded free at <http://www.aami.org/publications/standards/st79.html>

ANSI/AAMI Comprehensive Guide to Steam Sterilization and Sterility Assurance in Health Care Facilities. ANSI/AAMI ST79:2010 & A1:2010 & A2:2011 (Consolidated text)

Order code: ST79 or ST79-PDF

Available in print or electronic format.

AAMI documents can be purchased through AAMI by credit card using the following four options:

1. Internet: <http://www.aami.org/publications/standards/st79.html>
2. Call: 1-877-249-8226
3. Fax: 1-301-206-9789
4. Mail: AAMI publications, PO Box 2011, Annapolis Junction, MD 20701-0211

A free PDF of the newest and future amendment(s) may be downloaded by visiting the same internet site: <http://www.aami.org/publications/standards/st79.html>

References

- Eaton, Joe. *Filthy surgical instruments: The hidden threat in America's operating rooms*. Accessed 6/25/2012 at: <http://www.iwatchnews.org/2012/02/22/8207/filthy-surgical-instruments-hidden-threat-americas-operating-rooms>
- 2011 AAMI/FDA Medical Device Reprocessing Summit. Accessed 6/25/2012 at: <http://www.aami.org/meetings/summits/reprocessing.html>
- ECRI. *Health Devices: Top 10 Health Technology Hazards for 2012*. Accessed 6/25/2012 at: https://www.ecri.org/Documents/Secure/Health_Devices_Top_10_Hazards_2012.pdf.
- Association for the Advancement of Medical Instrumentation. *Sterilization and Reprocessing – A Matter of Patient Safety*. Horizons, Spring 2012. Access 6/25/2012 at: <http://aami-bit.org/toc/bmit/46/sp12>
- 3M™ Attest™ 1291 Rapid Readout Biological Indicator package insert. Accessed 6/25/2012 at: http://multimedia.3m.com/mws/mediawebserver?mwsld=SSSSSufSevTsZxtUNY_1o8t9evUqevTSevTSeSSSSSS--&fn=34-7055-0467-7_EN.pdf
- 3M™ Attest™ 1292 Rapid Readout Biological Indicator package insert. Accessed 6/25/2012 at: http://multimedia.3m.com/mws/mediawebserver?mwsld=SSSSSufSevTsZxtUNY_1o8t1evUqevTSevTSeSSSSSS--&fn=34-7058-3151-8_EN.pdf
- Association for the Advancement of Medical Instrumentation. *Comprehensive Guide to Steam Sterilization and Sterility Assurance in Health Care Facilities*. ANSI/AAMI ST9:2010 & A1:2010 & A2:2011 (Consolidated text). Arlington, VA: AAMI, 2010. www.aami.org
- Eiland, John E. *Joint Commission presentation at IAHCsMM annual meeting in April 2012*. Presentation available on flash drive provided to attendees. Martha Young attended presentation.
- Steris® Verify® SixCess® Chemical Indicator and Challenge Pack literature. Accessed 6/25/2012 at: <http://www.steris.com/documents.cfm?id=M3500EN>
- Steris® Verify® SixCess™ Challenge Pack Selection and Interpretation Guide. Accessed 6/25/2012 at: <http://www.steris.com/documents.cfm?id=M3130CA>
- Zimmer. *Manual Orthopaedic Surgical Instruments, Recommendations for Care, cleaning, Maintenance and Sterilization*. Accessed 6/25/2012 at: http://www.zimmer.com/content/pdf/en-US/Manual_Orthopaedic_Surgical_Instruments_97500017000_R3_05_2010%20English.pdf
- Synthes®. *Processing Synthes Reusable Medical Devices – Instruments, Instrument Trays and Graphic Cases*. Accessed 6/25/2012 at: http://www.synthes.com/sites/NA/NAContent/Docs/Product%20Support%20Materials/Processing%20Forms/SUSA/Processing%20Non-sterile%20Instruments_DJ1305%20rev%20H.pdf
- International Association of Healthcare Central Service Materiel Management. *Position Paper on the Management of Loaner Instrumentation and Sample Policy & Procedure for Loaner Instrumentation*. Accessed 6/25/2012 at: http://iahcsmm.org/CurrentIssues/Loaner_Instrumentation_Position_Paper_Sample_Policy.html
- How to add more teeth to your loaner set policy. *OR Manager*, Vol. 28, No 6, June 2012, pp. 22-25.
- Case Medical, Inc.® *SteriTite-The Container System of Choice*. Access 6/25/2012 at: http://www.casemed.com/Docs/CaseMedicalIFU_RevM.pdf
- Aesculap®. *Instructions for Use for SterileContainer™ System and SterilContainer S™ System in Steam Sterilization*. Access 6/25/2012 at: http://www.aesculapusa.com/assets/base/doc/instructions/aic/sterilcontainers/SterilContainer_System_and_SterilContainer_S_System_in_Steam_Sterilization_SOP-AIC-5000238.pdf
- Aesculap®. *STERILCONTAINER™ System with PrimeLine Lid*. Accessed 6/25/2012 at: [http://www.aesculapusa.com/assets/base/doc/instructions/aic/sterilcontainers/SterilcontainerSystemwithPrimelinLidSOP-AIC-5000258\(2-24-10\).pdf](http://www.aesculapusa.com/assets/base/doc/instructions/aic/sterilcontainers/SterilcontainerSystemwithPrimelinLidSOP-AIC-5000258(2-24-10).pdf)
- Association of periOperative Registered Nurses. *Recommended practices for selection and use of packaging systems for sterilization AORN Perioperative Standards and Recommended Practices*. Denver, CO. AORN Inc, 2012.
- The Basics of Sterile Processing*. Chapter 7: Preparation, Packaging, and Instrumentation. Fourth Edition 2012. Sterile Processing University, LLC. Lebanon, New Jersey.

Answers

1. A
2. A
3. A
4. B
5. A
6. B
7. B
8. B
9. A
10. A

Martha Young, BS, MS, CSPDT

Martha Young, BS, MS, CSPDT, is president of Martha L. Young, LLC, providing SAVVY sterilization solutions to health-care manufacturers and facilities and a consultant for 3M Health Care, Infection Prevention Division. She retired from the 3M Infection Prevention Division, St. Paul, MN in 2009 after 31 years and

has over 34 years of experience in the specialty area of cleaning/disinfection and sterilization. Ms. Young has lectured around the world, has over 60 publications on infection prevention with an emphasis on how to improve the performance of the sterilization process, and writes a quarterly column for OR Manager. She is a member of IAHCSSM, AORN (Past Professional/Practice Issues Chair for AORN Speciality Assembly for Sterilization Processing and Materials Management from 2006–2010), APIC and a certified Central Sterile Processing and Distribution Technician. Additionally, Ms. Young is the APIC representative to AAMI and has been a voting member of several AAMI working groups developing recommended practices for over 20 years. In 2007 HPN acknowledged her as one of the “30 Pros Worth Knowing” who are the Most Influential in Healthcare Sterile Processing. Ms. Young can be reached at marthayoung1@aol.com.

Ms. Young is a consultant for 3M HealthCare, Infection Prevention Division.

Sterile Process and Distribution CE Information

CE Applicant Name: _____

City: _____

Address: _____

State: _____ Zip Code: _____

The CBSPD (Certification Board for Sterile Processing and Distribution) has pre-approved this inservice for 1.5 contact hours for a period of five (5) years from the date of publication. Successful completion of the lesson and post test must be documented by facility management and those records maintained by the individuals until re-certification is required. DO NOT SEND LESSON OR TEST TO CBSPD.

For additional information regarding Certification contact: CBSPD, Inc. 148 Main St., Lebanon, NJ, 08833 or call 908-236-0530 or 1-800-555-9765 or visit the website at www.sterileprocessing.org.

IAHCSMM has awarded 1.5 approved contact hours for completion of this continuing education lesson toward IAHCSMM recertification.

Nursing CE Application Form

This inservice is approved by the California Board of Registered Nurses, CEP 5770 for 1 contact hour. This form is valid up to five (5) years from the date of publication.

- | | |
|--|--|
| <ol style="list-style-type: none"> 1. Make a photocopy of this form. 2. Print your name, address and daytime phone number and position/title. 3. Add the last 4 digits of your social security number or your nursing license number. 4. Date the application and sign. 5. Answer the true/false CE questions. Keep a copy for your records. | <ol style="list-style-type: none"> 6. Submit this form and the answer sheet to:
3M Infection Prevention
Attn: HC4160
RR Donnelly Fulfillment Services
585 Hale Avenue North
Oakdale, MN 55128-9935 7. For questions please call the 3M Healthcare helpline: 1-800-228-3957. 8. Participants who score at least 70% will receive a certificate of completion within 30 days of RR Donnelly's receipt of the application. |
|--|--|

Application *Please print clearly or type.*

Name: _____

Daytime phone: () _____

Mailing Address: _____

Position/Title: _____

City: _____

Social Security or Nursing License Number: _____

State: _____ Zip Code: _____

Date application submitted: _____

Country: _____

Signature: _____

Offer expires July, 2017



Infection Prevention Division
3M Health Care
 3M Center, Building 275-4E-01
 St. Paul, MN 55144-1000
 U.S.A.
 1 800 228-3957
www.3M.com/infectionprevention

Please recycle. Printed in U.S.A.
 3M is a trademark of 3M.
 © 3M 2012. All rights reserved.