

# AN10973

## Using the LPC13xx low power modes and wake-up times on the LPCXpresso

Rev. 2 — 6 January 2011

Application note

### Document information

Info	Content
<b>Keywords</b>	LPC134x, LPC131x, Low Power Modes, Power Consumption, Wake-up, code example, LPCXpresso
<b>Abstract</b>	<p>This application note introduces the various low power modes of the LPC134x and LPC131x series, the steps required to enter the low power modes, wake-up implementation, and helpful hints to reduce power consumption.</p> <p>This application note also provides a software example to enter the low power modes, and demonstrates how to measure the power consumption and wake-up times using the LPC1343 LPCXpresso board.</p>



**Revision history**

Rev	Date	Description
2	20110106	Second version. Small edits to title and abstract.
1	20100908	Initial version.

**Contact information**

For additional information, please visit: <http://www.nxp.com>

For sales office addresses, please send an email to: [salesaddresses@nxp.com](mailto:salesaddresses@nxp.com)

## 1. Introduction

The LPC1300 microcontroller family is based on the ARM Cortex-M3 CPU architecture for embedded applications featuring a high level of support block integration and low power consumption. The LPC1300 microcontrollers incorporate key features like the AHB Lite Bus, Nested Vectored Interrupt Controller (NVIC) integrated with a SYSTICK timer, three reduced power modes, and on-chip drivers for MSC and HID (LPC134x only).

The peripheral complement of the LPC1300 family includes up to 32 kB of flash memory, up to 8 kB of data memory, USB Device, one Fast-mode Plus (FM+) I2C interface, one UART, four general purpose timers, and up to 42 general purpose I/O pins.

The LPC1300 series targets a wide range of applications, including eMetering, lighting, industrial networking, alarm systems, white goods and motor control.

This application note introduces the various low power modes of the LPC134x and LPC131x parts, the steps required to enter the low power modes, wake-up implementation, and helpful hints to reduce power consumption. This application note also provides software examples to enter and wake-up from the low power modes, and demonstrates how to measure the power consumption and wake-up times using the LPC1343 LPCXpresso board.

The various topics covered in this application note are as follows:

1. Low Power Modes
2. Entering Low Power Modes
3. Wake-Up Implementation
4. Additional hints to reduce power consumption
5. Low power mode demos using the LPC1343 LPCXpresso board

This application note applies to the following part type numbers:

Type number	Flash	Total SRAM	USB	UART RS-485	I <sup>2</sup> C/ Fast+	SSP	ADC channels	Pins	Package
LPC1311FHN33	8 kB	4 kB	-	1	1	1	8	33	HVQFN33
LPC1313FBD48	32 kB	8 kB	-	1	1	1	8	48	LQFP48
LPC1313FHN33	32 kB	8 kB	-	1	1	1	8	33	HVQFN33
LPC1342FHN33	16 kB	4 kB	Device	1	1	1	8	33	HVQFN33
LPC1343FBD48	32 kB	8 kB	Device	1	1	1	8	48	LQFP48
LPC1343FHN33	32 kB	8 kB	Device	1	1	1	8	33	HVQFN33

019aab329

Fig 1. LPC131x and LPC134x devices

## 2. Low power modes

---

On the LPC134x and LPC131x series, there are three reduced power modes: Sleep, Deep-Sleep, and Deep Power-down modes. The following sections cover the features and configurations for the low power modes.

### 2.1.1 Sleep mode

In Sleep mode, the system clock to the ARM Cortex-M0 core is stopped, and execution of instructions is suspended until either a reset or an enabled interrupt occurs.

Peripheral functions, if selected to be clocked in the SYSAHBCLKCTRL register, continue operation during Sleep mode and may generate interrupts to cause the processor to resume execution. Sleep mode eliminates dynamic power used by the processor itself, memory systems and their related controllers, and internal buses. The processor state and registers, peripheral registers, and internal SRAM values are maintained, and the logic levels of the pins remain static.

### 2.1.2 Deep-sleep mode

In Deep-sleep mode, the system clock to the processor is disabled as in Sleep mode. All analog blocks are powered down, except for the BOD circuit and the watchdog oscillator, which must be selected or deselected during Deep-sleep mode in the PDSLEEPCFG register. This will be covered later.

Deep-sleep mode eliminates all power used by the flash, analog peripherals and all dynamic power used by the processor itself, memory systems and their related controllers, and internal buses. The processor state and registers, peripheral registers, and internal SRAM values are maintained, and the logic levels of the pins remain static.

### 2.1.3 Deep power-down mode

In Deep Power-down mode, power and clocks are shut off to the entire chip with the exception of the  $\overline{\text{WAKEUP}}$  pin.

During Deep power-down mode, the contents of the SRAM and registers are not retained except for a small amount of data which can be stored in five 32-bit general purpose registers of the power management unit block.

All functional pins are tri-stated in Deep power-down mode except for the  $\overline{\text{WAKEUP}}$  pin.

## 3. Entering the low power modes

---

This section describes the mechanism to put the LPC134x and LPC131x into the three low power modes (sleep, deep-sleep, deep power-down).

### 3.1 System Control Register (SCR)

The SCR register controls features of entry to and exit from low power modes.

Sleep mode and Deep Sleep mode are selected by the SLEEPDEEP bit in the Cortex-M3 System Control Register (SCR).

The bit assignments are shown in [Fig 2](#).

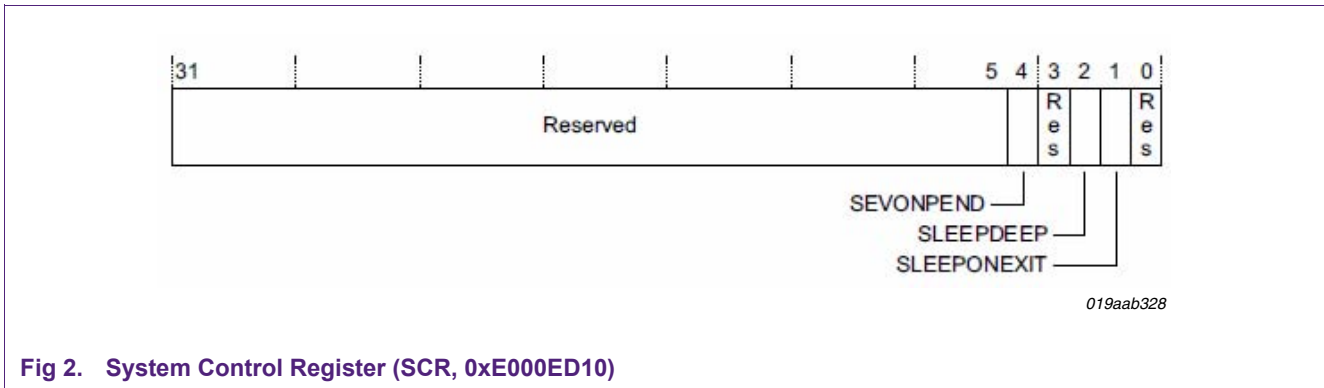

Fig 2. System Control Register (SCR, 0xE00ED10)

If the SLEEPDEEP bit in the Cortex-M3 System Control Register (SCR) is 0, Sleep mode is selected.

If the SLEEPDEEP bit in the Cortex-M3 System Control Register (SCR) is 1, Deep-sleep mode is selected.

If the SLEEPONEXIT bit of the SCR is set to 1, the processor completes the execution of an exception handler and immediately enters Sleep mode. This mechanism is useful for applications that only require the processor to run when an exception occurs. If SLEEPON EXIT bit is set in the System Control Register, core will automatically enter the low power mode once the ISR has completed. This allows a low power application to be entirely interrupt-driven, so that the Cortex core will wake up, run the appropriate code and then re-enter the mode with minimal code being used for power management

### 3.2 Power Control Register (PCON)

The PCON register selects whether one of the ARM Cortex-M3 controlled power-down modes (Sleep mode or Deep-Sleep mode) or the Deep power-down mode is entered. It also provides the flags for Sleep or Deep-sleep modes and Deep power-down modes respectively. See [Fig 3](#) below.

Table 58. Power control register (PCON, address 0x4003 8000) bit description

Bit	Symbol	Value	Description	Reset value
0	-	-	Reserved. Do not write 1 to this bit.	0x0
1	DPDEN		Deep power-down mode enable	0
		0	ARM WFI will enter Sleep or Deep-sleep mode (clock to ARM Cortex-M3 core turned off).	
		1	ARM WFI will enter Deep-power down mode (ARM Cortex-M3 core powered-down).	
7:2	-	-	Reserved. Do not write ones to this bit.	0x0
8	SLEEPFLAG		Sleep mode flag	0
		0	Read: No power-down mode entered. LPC13xx is in Run mode. Write: No effect.	
		1	Read: Sleep/Deep-sleep or Deep power-down mode entered. Write: Writing a 1 clears the SLEEPFLAG bit to 0.	
10:9	-	-	Reserved. Do not write ones to this bit.	0x0
11	DPDFLAG		Deep power-down flag	0x0
		0	Read: Deep power-down mode <b>not</b> entered. Write: No effect.	0x0
		1	Read: Deep power-down mode entered. Write: Clear the Deep power-down flag.	0x0
31:12	-	-	Reserved. Do not write ones to this bit.	0x0

019aab330

Fig 3. Power Mode Control Register (PCON)

### 3.3 Wait For Interrupt (WFI) instruction

Execution of the WFI instruction will cause immediate entry to any of the low reduced power modes based on the SLEEPDEEP bit and PCON register settings mentioned above.

The WFI instruction is a Cortex-M3 instruction which cannot be directly accessible by ANSI C. The CMSIS (Cortex Microcontroller Software Interface Standard) provides an intrinsic function to generate a WFI instruction and is supported by C compiler.

If a C compiler does not support the WFI intrinsic function, then the user will have to use assembly code to execute WFI instruction.

### 3.4 Programming steps to enter sleep mode

The following steps must be performed to enter sleep mode:

1. The DPDFLAG bit in the PCON register must be set to zero.

2. The SLEEPDEEP bit in the ARM Cortex-M3 SCR register must be set to zero.
3. Use the ARM Cortex-M0 Wait-For-Interrupt (WFI) instruction.

Fig 4 below shows code example to enter sleep mode.

```

/* Clear the Deep Power down flag from the PMU */
LPC_PMU->PCON |= (1<<11);

/* Specify Sleep mode before entering mode */
SCB->SCR    &= ~(1<<2);    //Clear SLEEPDEEP bit

/* Enter Sleep mode */
__WFI();
    
```

019aab331

Fig 4. Code example (Sleep mode)

### 3.5 Programming steps to enter Deep-sleep mode

The following steps must be performed to enter Deep-sleep mode:

1. The DPDEN bit in the PCON register must be set to zero.
2. Select the power configuration in Deep-sleep mode in the PDSLEEPCFG register. This register controls the behavior of the WatchDog (WD) oscillator and the BOD circuit when the device enters the Deep-sleep mode. This register must be initialized at least once before entering Deep-sleep mode with one of the four values shown below. Failure to initialize and program this register correctly may result in undefined behavior of the microcontroller. The values listed in the Fig 5 below are the only values allowed for PDSLEEPCFG register.

Allowed values for PDSLEEPCFG register

Configuration	WD oscillator on	WD oscillator off
BOD on	PDSLEEPCFG = 0x0000 0FB7	PDSLEEPCFG = 0x0000 0FF7
BOD off	PDSLEEPCFG = 0x0000 0FBF	PDSLEEPCFG = 0x0000 0FFF

019aab332

Fig 5. PDSLEEPCFG Register Settings (Deep-sleep mode)

- a. If a timer controlled self wake-up is needed, ensure the watchdog oscillator is powered in the PDRUNCFG register and switch the clock source to WD oscillator in the MAINCLKSEL register (see LPC13xx User Manual for details).
- b. The watchdog oscillator can be left running in Deep-sleep mode to provide a clock for the watchdog timer or a general purpose timer if they are needed for self-wake-up purposes. This will be discussed later in the wake-up implementation section. In this case, the watchdog oscillator analog output frequency must be set to its lowest value (bits FREQSEL in the WDTOSCCTRL = 0001, see LPC13xx User Manual) and all peripheral clocks other than timer clock must be disabled in the SYSAHBCLKCTRL register before entering the Deep-sleep mode. The



- watchdog oscillator, if running, contributes an additional current drain in Deep-sleep mode.
- c. If no timer-controlled self wake-up is needed and the watchdog oscillator is shut down, ensure that the IRC is powered in the PDRUNCFG register and switch the clock source to IRC in the MAINCLKSEL register before entering deep sleep mode. This ensures that the system clock is shut down glitch-free (see the LPC13xx User Manual for details).
  - d. Leaving the BOD circuit enabled will protect the device from a low voltage event occurring while the micro is in Deep-sleep mode. However, the BOD circuit causes an additional current drain in Deep-sleep mode.
3. Select the power configuration after wake-up in the PDAWAKECFG register. The bits in this register can be programmed to determine the state the chip must enter when it is waking up from Deep-sleep mode.
  4. If an external pin is used for wake-up, enable and clear the wake-up pin in the start logic registers, and enable the interrupt associated to that start logic in the NVIC.
  5. In the SYSAHBCTRL register, disable all peripherals except the counter/timer or WDT if needed.
  6. Write one to the SLEEPDEEP bit in the ARM Cortex-M3 SCR register.
  7. Use the ARM Cortex-M3 Wait-For-Interrupt (WFI) instruction.

[Fig 6](#) below shows code example to enter Deep-sleep mode.



```

/* Turn on the IRC & Flash */
LPC_SYSCON->PDRUNCFG &= ~(1<<0) | (1<<1) | (1<<2));

/* Switch MAINCLKSEL to IRC */
LPC_SYSCON->MAINCLKSEL = 0;
LPC_SYSCON->MAINCLKUEN = 0;
LPC_SYSCON->MAINCLKUEN = 1;
while (!(LPC_SYSCON->MAINCLKUEN & 0x01));

/* Ensure DPDEN is disabled in the power control register */
LPC_PMU->PCON = (1<<11); //Clear DPDFLAG if it was set

/* All OFF */
LPC_SYSCON->PDSLEEPCFG = 0x00000FFF;

/* Specify peripherals to be powered up again when returning from deep sleep mode */
LPC_SYSCON->PDWAKECFG = LPC_SYSCON->PDRUNCFG;

/* Specify the start logic to allow the chip to be waken up */
LPC_SYSCON->STARTAPRP0 &= ~(1<<(2)); // Falling edge
LPC_SYSCON->STARTRSRPOCLR |= (1<<(2)); // Clear pending bit
LPC_SYSCON->STARTERP0 |= (1<<(2)); // Enable Start Logic

NVIC_ClearPendingIRQ(WAKEUP2_IRQn);
NVIC_EnableIRQ(WAKEUP2_IRQn);

/* Specify Deep Sleep mode before entering mode */
SCB->SCR |= (1<<2); //Set SLEEPDEEP bit

/* Enter Deep Sleep mode */
__WFI();

```

019aab333

Fig 6. Code example (Deep-sleep mode)

### 3.6 Programming steps to enter Deep power-down mode

The following steps must be performed to enter Deep power-down mode:

1. Write one to the DPDEN bit in the PCON register.
2. Store data to be retained in the general purpose registers (see the LPC13xx User Manual for details).
3. Write one to the SLEEPDEEP bit in the ARM Cortex-M3 SCR register.
4. Ensure that the IRC is powered by setting bits IRCOUT\_PD and IRC\_PD to zero in the PDRUNCFG register before entering Deep power-down mode.
5. Use the ARM Cortex-M3 Wait-For-Interrupt (WFI) instruction.

**Please note** that the  $\overline{\text{WAKEUP}}$  pin needs to be externally pulled HIGH before entering deep power-down mode.

```
/* Specify DPDEN to power control register */
LPC_PMU->PCON      = (1<<1) | (1<<11);

/* Specify Deep Power-down mode before entering mode */
SCB->SCR           |= (1<<2);      //Set SLEEPDEEP bit

/* Enable IRC before deep power-down mode */
LPC_SYSCON->PDRUNCFG &= ~(1<<0) | (1<<1));

/* Enter Deep Power-down mode */
__WFI();
```

019aab334

Fig 7. Code example (Deep power-down mode)

### 3.7 Wake-up implementation

The following section describes the wake-up implementation for each low power mode on the LPC134x and LPC131x.

#### 3.7.1.1 Wake-up from Sleep mode

Sleep mode is exited automatically when an interrupt enabled by the NVIC arrives at the processor or a reset occurs. Please see the LPC13xx User Manual for details on which interrupt sources are connected to NVIC. After wake-up due to an interrupt, the microcontroller returns to its original power configuration defined by the contents of the PDRUNCFG and the SYSAHBCLKDIV registers. If a reset occurs, the microcontroller enters the default configuration in Active mode.

#### 3.7.1.2 Wake-up from Deep-sleep mode

The microcontroller can wake up from Deep-sleep mode in the following ways:

1. Signal on an external pin which is connected to start logic. For this purpose, certain port pins can be enabled as inputs to the start logic. Please see the LPC13xx User Manual for which port pins are connected to the start logic and serve as wake-up pins. The start logic does not require any clocks and generates the interrupt if enabled in the NVIC to wake up from Deep-sleep mode.
2. Input signal to the start logic created by a match event on one of the general purpose timer external match outputs. The pin holding the timer match function must be enabled as start logic input in the NVIC, the corresponding timer must be enabled in the SYSAHBCLKCTRL register, and the watchdog oscillator must be running in Deep-sleep mode (see the LPC13xx User Manual for details). This wake-up scheme will allow for the device to self wake-up when the match output is triggered. It will then feed back into the start logic causing the device to self wake-up as shown in [Fig 8](#). No external trigger is required for this method and as a result, this reduces external components on the board. However, using this method causes the wake-up time to be longer than option 1 mentioned above (external triggered wake-up). The wake-up times will be discussed later in the demo section.

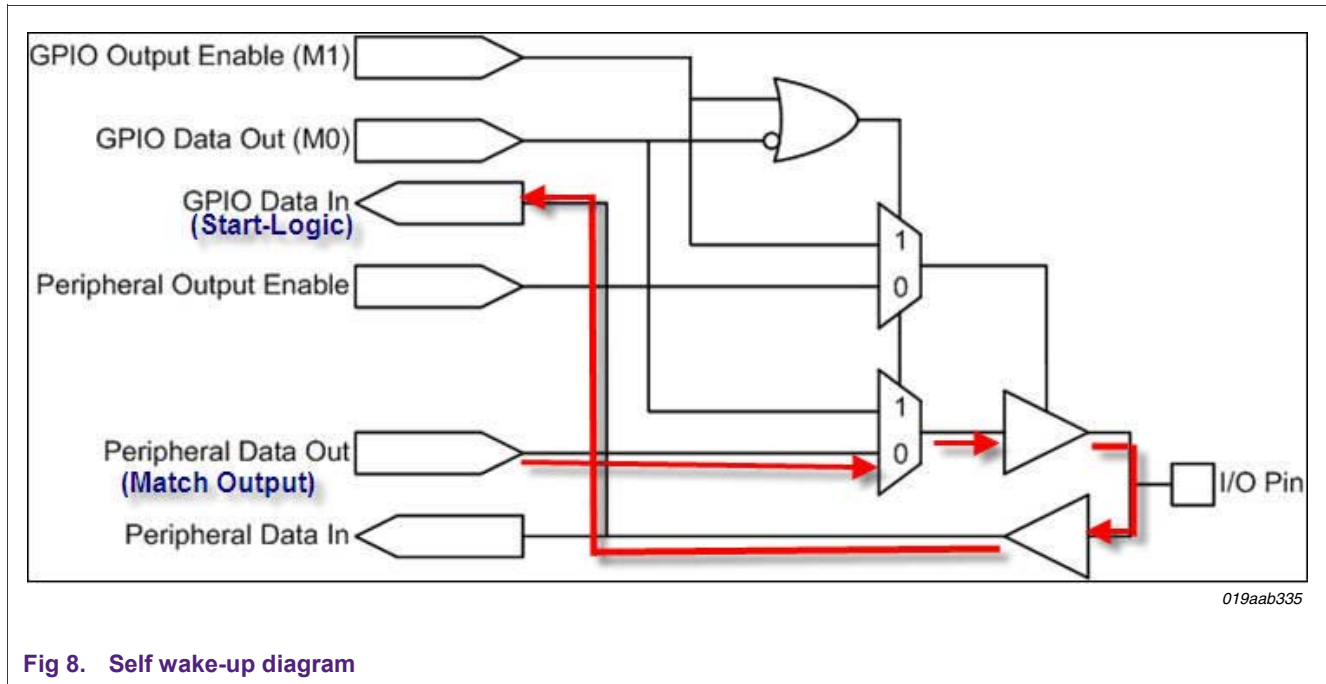

Fig 8. Self wake-up diagram

3. Reset from the BOD circuit. In this case, the BOD circuit must be enabled in the PDSLEEPCFG register, and the BOD reset must be enabled in the BODCTRL register (See the LPC13xx User Manual for details).
4. Reset from the watchdog timer. In this case, the watchdog oscillator must be running in Deep-sleep mode (see PDSLEEPCFG register), and the WatchDog Timer peripheral must be enabled in the SYSAHBCLKCTRL register.
5. External  $\overline{\text{RESET}}$  pin.

**3.7.1.3 Wake-up from Deep power-down mode**

Pulling the  $\overline{\text{WAKEUP}}$  pin LOW wakes up from Deep power-down, and the chip performs a reset process. Minimum low pulse width for  $\overline{\text{WAKEUP}}$  pin is 50 ns.

1.  $\overline{\text{WAKEUP}}$  is generated when an external HIGH to LOW transition occurs on the  $\overline{\text{WAKEUP}}$  pin (level-sensitive).
  - a. The Power Management Unit (PMU) will turn on the on-chip voltage regulator. When the core voltage reaches the power-on-reset (POR) trip point, a system reset will be triggered and the chip re-boots.
  - b. All registers except the GPREG0 to GPREG4 and PCON will be in their reset state.
2. Once the chip has booted, the deep power-down flag can be read in the PCON register to verify that the reset was caused by a wake-up event from Deep power-down.
3. Clear the deep power-down flag in the PCON register.
4. (Optional) Read the stored data in the general purpose registers.

**Please note** that the  $\overline{\text{RESET}}$  pin has no functionality in Deep power-down mode.

### 3.8 Additional tips to reduce power consumption

The current consumption can be further reduced by considering the following points:

#### 3.8.1.1 CPU clock rate

The CPU clock rate can be controlled as needed, which allows a trade-off of power versus processing speed based on application requirements.

1. Changing clock sources: Internal Oscillator (12 MHz +/- 1 %), System Oscillator (1 MHz to 25 MHz), Watchdog Oscillator (7.8 kHz to 1.7 MHz +/- 40 %).
2. Reconfiguring PLL values, and/or altering the AHB Clock Divider (SYSAHBCLKDIV) value.
3. Lowering the PLL0's output frequency (FCCO, 156 MHz to 320 MHz) can also save power.
4. An 8-bit system AHB clock divider register (SYSAHBCLKDIV) allows a range of options, including slowing CPU operation to a low rate for temporary power savings without turning off SYS PLL. See [Fig 9](#) below.

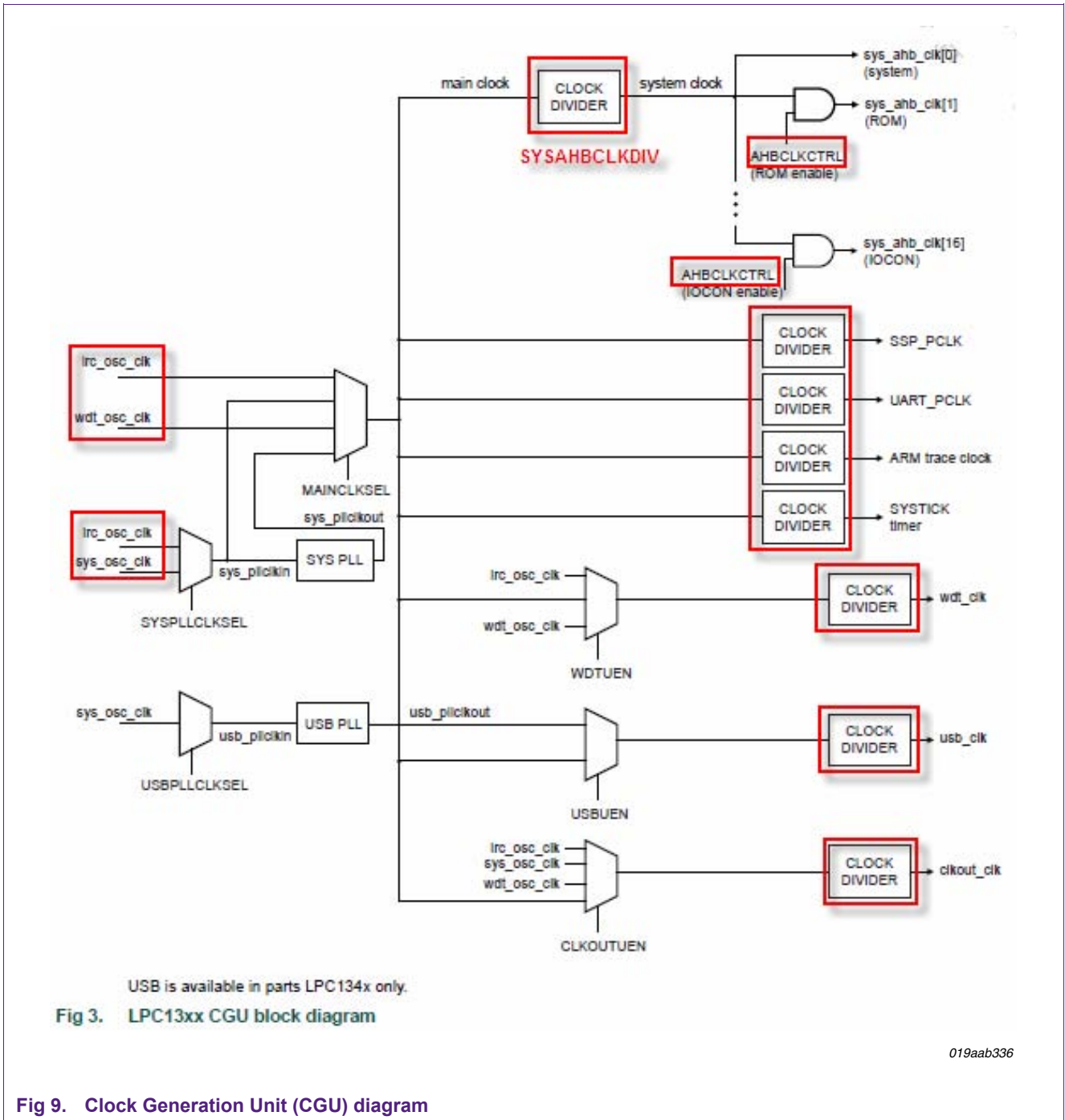

### 3.9 System AHB Clock Control Register (AHBCLKCTRL)

As shown in the [Fig 9](#), the SYSAHBCLKCTRL register enables the clocks to individual system and peripheral blocks. Depending upon application requirements, the user can use this register to reduce power by disabling clocks to unused peripherals. See the LPC13xx User Manual for details.

### 3.10 Peripheral clock dividers

Selected peripherals have their own clock divider (SSPCLKDIV, UARTCLKDIV, TRACECLKDIV, SYSTICKCLKDIV, USBCLKDIV, WDTCLKDIV, CLKOUTDIV) which controls the rate of the peripheral clock signal that will be supplied to the corresponding peripheral (see [Fig 9](#)). Depending on application requirements, the user can use these divider registers to reduce the peripheral clock frequency or shut down the clock to reduce power. See the LPC13xx User Manual for details.

### 3.11 Power-down Configuration register (PDRUNCFG)

PDRUNCFG Register contains control bits that power on or off individual analog blocks, allowing elimination of power consumption by analog peripherals that are not needed. See the LPC13xx User Manual for details.

### 3.12 Miscellaneous

#### 3.12.1 Software

Most embedded applications terminate with a while(1) loop, and they service interrupts whenever needed. In this case, code is still constantly fetched from the on-chip flash and executed which adds to the power consumption. A better solution would be to switch to the sleep power saving mode and then wait for interrupts. An interrupt from a peripheral would then wake the device from Sleep mode. Considerable power savings can be achieved by keeping the core in Sleep mode while it is waiting for interrupts.

#### 3.12.2 Port pins

Additional steps can be used to reduce current consumption on the IO current in the low power modes. The general purpose port pins on the LPC1300 series have programmable internal pull-ups enabled by default. Before entering low power modes, reduce the IO current as follows:

1. All General Purpose I/O pins (GPIO) default to input with pull-up resistor enabled. Using the IOCON registers, first, disable the internal pull-ups on all general port pins. Second, configure the IOs as GPIO outputs and drive them low. Make sure the pins are not being externally pulled high, OR
2. All General Purpose I/O pins (GPIO) default to input with pull-up resistor enabled. Using the IOCON registers, first, disable the internal pull-ups on all general port pins. Second, configure the IOs as GPIO outputs and drive them high. Make sure the pins are not being externally pulled low, OR
3. Using the IOCON registers, first disable the internal pull-ups on all general port pins. Second, configure the IOs as GPIO inputs and using an external resistor, pull the IOs high or low.

Please note that in deep power-down mode, state of the port pins does not affect the current consumption and the steps mentioned above do not need to be considered in this mode.

### 3.12.3 USB pins

On the LPC134x devices, when not using the USB device, the USB pins (USB\_DP and USB\_DM) should be externally pulled low to reduce the IO current.

### 3.12.4 RESET\_N/PIO0\_0 pin

On the LPC13xx devices, the  $\overline{\text{RESET}}$  /PIO0\_0 pin needs to be externally pulled up via 10k – 47k resistor when in deep power-down mode. If the pin is left floating, user will see an increase in current consumption.

### 3.12.5 Debug notes

The user should be aware of certain limitations during debugging. The most important is that, due to limitations of the Cortex-M3 integration, the LPC13xx cannot wake up in the usual manner from Sleep, Deep Sleep, or Deep power-down modes. It is recommended not to use these modes during debug. Once an application is downloaded via SWD interface, the USB to SWD debug adapter should be removed from the target board. Another issue is that debug mode changes the way in which reduced power modes are handled by the Cortex-M3 CPU. This causes power modes at the device level to be different from normal modes operation. These differences mean that power measurements should not be made while debugging; the results will be higher than during normal operation in an application.



## 4. Low power mode demos

### 4.1 Objective

This application note provides two low power mode examples using the LPCXpresso platform:

**Demo 1:** Low Power Modes (sleep, deep sleep, deep power-down) using the UART interface.

This example allows the user to enter the low power modes and wake-up using an external port pin.

**Demo2:** Self Wake-up Demo

This example configures the watchdog oscillator at lowest frequency to clock the 16-bit Timer 0 in run mode and deep-sleep mode. The device generates a repetitive self wake-up from deep-sleep mode and toggles a port pin when in run mode.

Both examples show the user how to measure the current and wake-up times. The following sections provide the necessary steps to set-up the low power mode demos on the LPCXpresso platform. Both project demos are CMSIS (Cortex Microcontroller Software Interface Standard) compliant.

### 4.2 LPCXpresso demonstrations

#### 4.2.1.1 Requirements

1. LPCXpresso IDE.
2. LPCXpresso Target Board (LPC1343) (see [Fig 10](#)).
3. LPCXpresso Base Board (see [Fig 10](#)).

The LPCXpresso Base Board contains a USB-to-Serial bridge chip (FT232R from FTDI) that connects the UART channel on the LPCXpresso target LPC1343 to a virtual COM port on the PC (via USB).

Please note that the Base Board is required only for Demo 1 which uses UART interface to display a power mode selection menu.

#### 4.2.1.2 Terminal window

For Demo 1, terminal window like TeraTerm or HyperTerminal window is needed to display the options to enter low power modes.

4.2.1.3 LPCXpresso target board (LPC1343)

**To measure the current:**

The LPCXpresso Target Board requires the following set-up for both demos:

1. The LPCXpresso target board includes an integrated JTAG debugger (LPC-Link). By default, the power is shared between the LPC1343 and LPC-Link. Trace connection between J4.1 and J4.2 needs to be cut to separate the power supply and thereafter, user can connect an external supply on J4.2 to measure the current using ammeter. The current should be measured at the VIO\_3V3X which supplies the power to the LPC1343. See Fig 10 below.
2. Since the software example is configuring all the pins as GPIO outputs and driving the GPIOs low, the external 12K pull-up resistor on RESET /PIO0\_0 needs to be removed. See Fig 10 below.
3. USB pins (USB-DM and USB-DP) needs to be externally grounded. See Fig 10 and Fig 11 below.

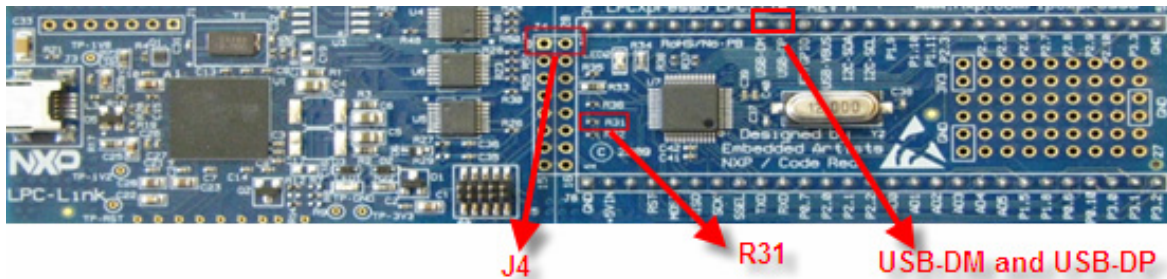

019aab337

Fig 10. LPCXpresso LPC1343 Target board

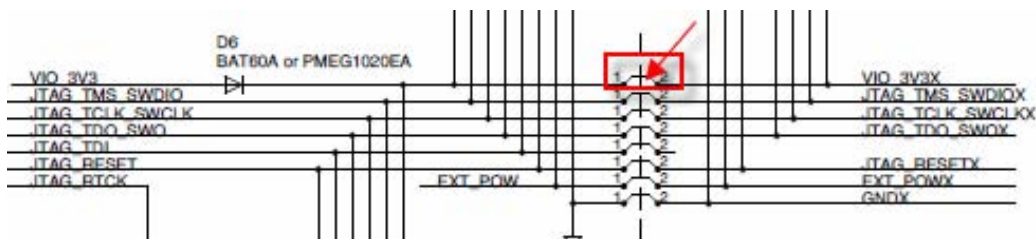

019aab338

Fig 11. LPCXpresso Target board Schematics

#### 4.2.1.4 LPCXpresso Base Board

As mentioned before, the Base Board is required only for Demo 1 and needs to be set-up as follows:

**To run the application:**

1. Remove the jumpers on PIO0\_2 and BL\_EN
2. Put a jumper between PIO0\_2 and BL\_EN  
PIO0\_2 is used as wake-up source for sleep and deep sleep.  
Push button 'BL\_EN' (SW3) will be used for sleep and deep sleep.
3. Remove the jumper on PIO1\_4.  
PIO1\_4 is multiplexed with WAKEUP functionality.  
Push button 'WAKEUP' (SW2) will be used to wake-up from deep power-down mode.
4. Keep the three jumpers closed on J7 (default state).  
This routes the UART pins to FTDI chip.
5. Remove the two jumpers on J54  
This removes control of DTR and RTS signals from the USB to UART bridge.

**To measure the current:**

6. After completion of steps 1-4, rest of the jumpers on the LPCXpresso Base Board would need to be removed to measure the current.

See [Fig 12](#) below for complete jumper set-up on the LPCXpresso base board.

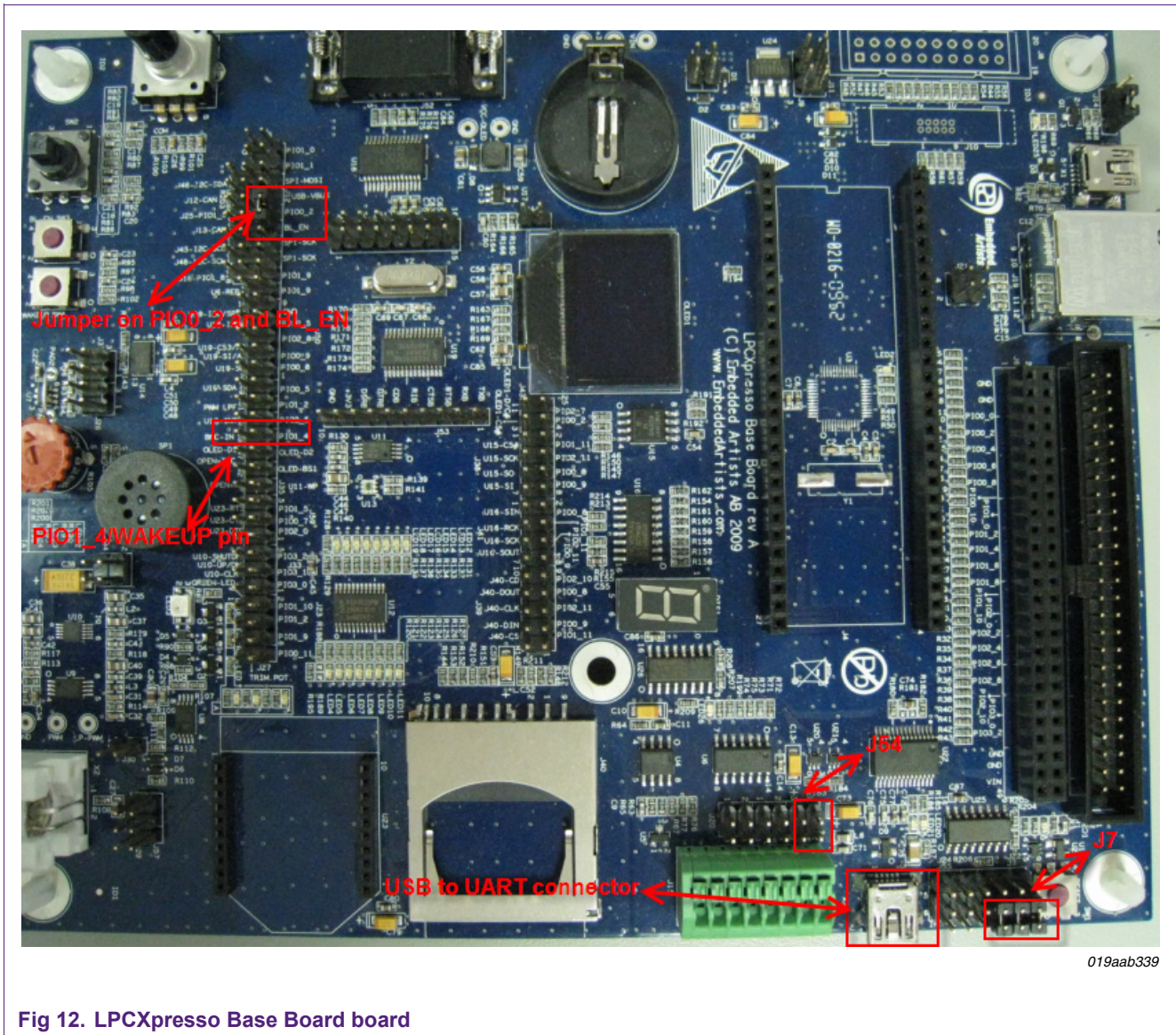

Fig 12. LPCXpresso Base Board board

#### 4.2.1.5 LPCXpresso Application Set-up for Demo 1

As mentioned before, demo 1 allows the user to enter the low power modes using UART interface, and wake-up using an external port pin.

Application is set-up as follows:

1. Connect the USB cable to power up the LPCXpresso LPC1343 target board.
2. Open LPCXpresso IDE and import LPC1300 wakeup.zip file.
3. Build the project by selecting the Build 'all projects' (Debug).
4. Download the code by selecting the Debug 'wake-up' (Debug).
5. Then terminate the debug session once code is downloaded.
6. Disconnect the USB cable from the LPCXpresso target board.
7. Attach the LPCXpresso target board to the LPCXpresso base board.



8. Connect a USB cable to power up the LPCXpresso target board.
9. Connect a USB cable to the USB to UART connector. (on the LPCXpresso Base Board). See [Fig 12](#).
10. User will be prompted **twice** to install the FTDI drivers for the USB to Serial chip (FT232R) to function.
  - a. Select the following path:  
C:\nxp\lpcxpresso\_3.3\Drivers\RedProbe
  - b. Select the following files:  
C:\nxp\lpcxpresso\_3.3\Drivers\RedProbe\i386\ftdibus.sys  
C:\nxp\lpcxpresso\_3.3\Drivers\RedProbe\i386\ftser2k.sys
  - c. Once installed, should see the following in device manager/properties ([Fig 13](#)):

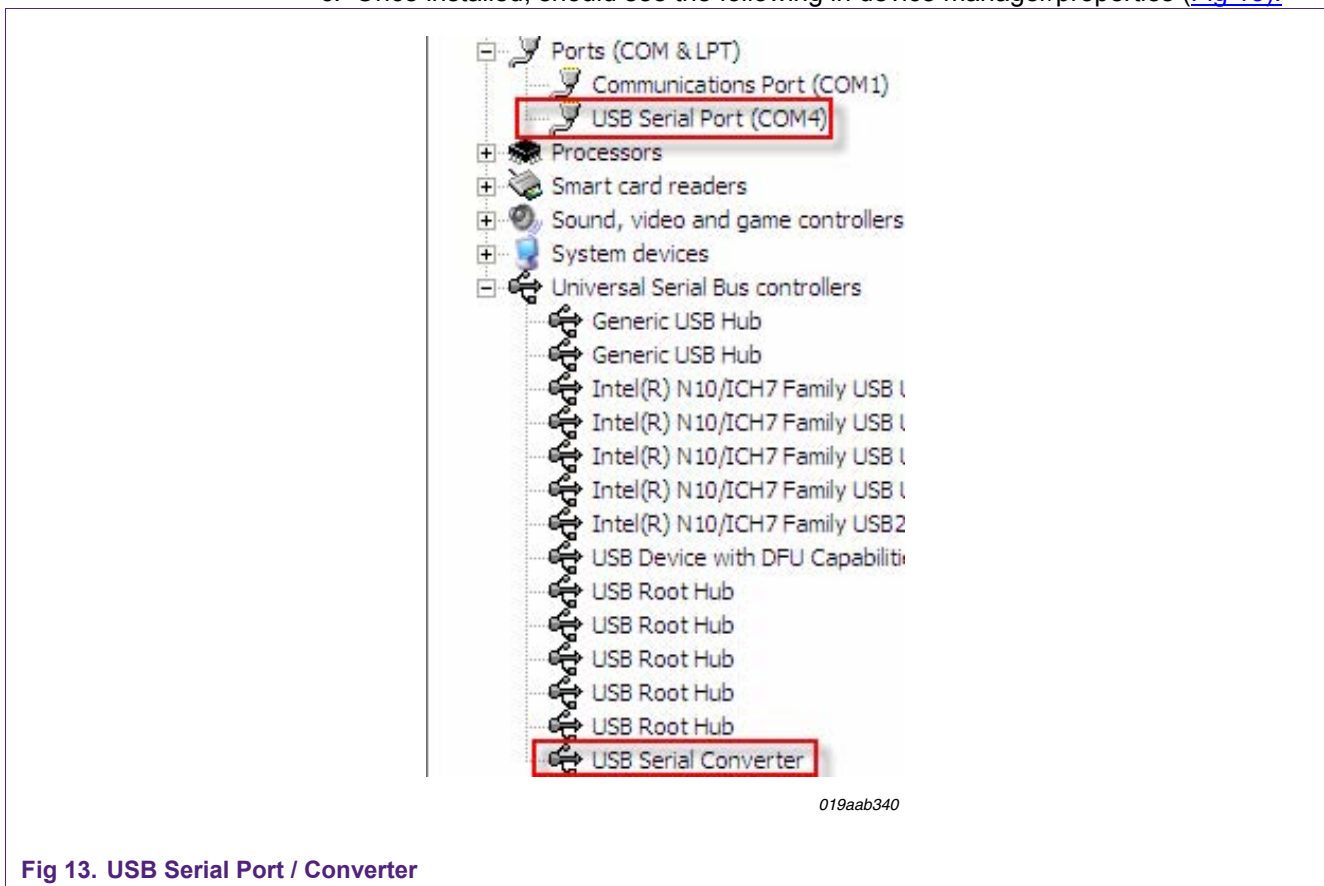

Fig 13. USB Serial Port / Converter

11. Some terminal programs need a low COM port number, for example between 1 and 5. Very often the COM port number for the USB Serial Port is higher than this, therefore this needs to be changed manually. If this is the case, then follow the additional steps as below. Further details can be found in the LPCXpresso Base Board User's Guide.
  - a. Go to Device Manager and Ports List.
  - b. Right click on USB Serial Port and select Properties.

- c. Go to Port Settings > Advanced to change COM Port Number as shown in the diagram below. COM port number will vary depending on the terminal program. In this example below, COM port number was changed to COM4.

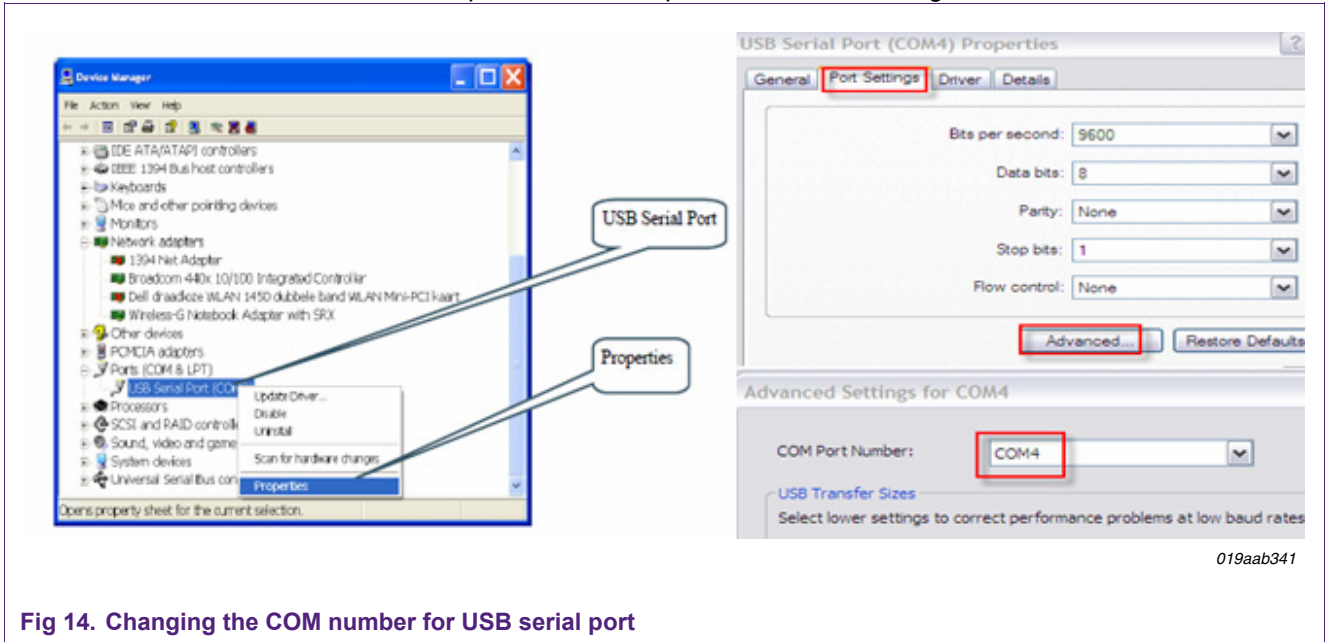

Fig 14. Changing the COM number for USB serial port

- 12. Demo 1 uses the terminal program and the settings for the serial port are shown in Fig 15.

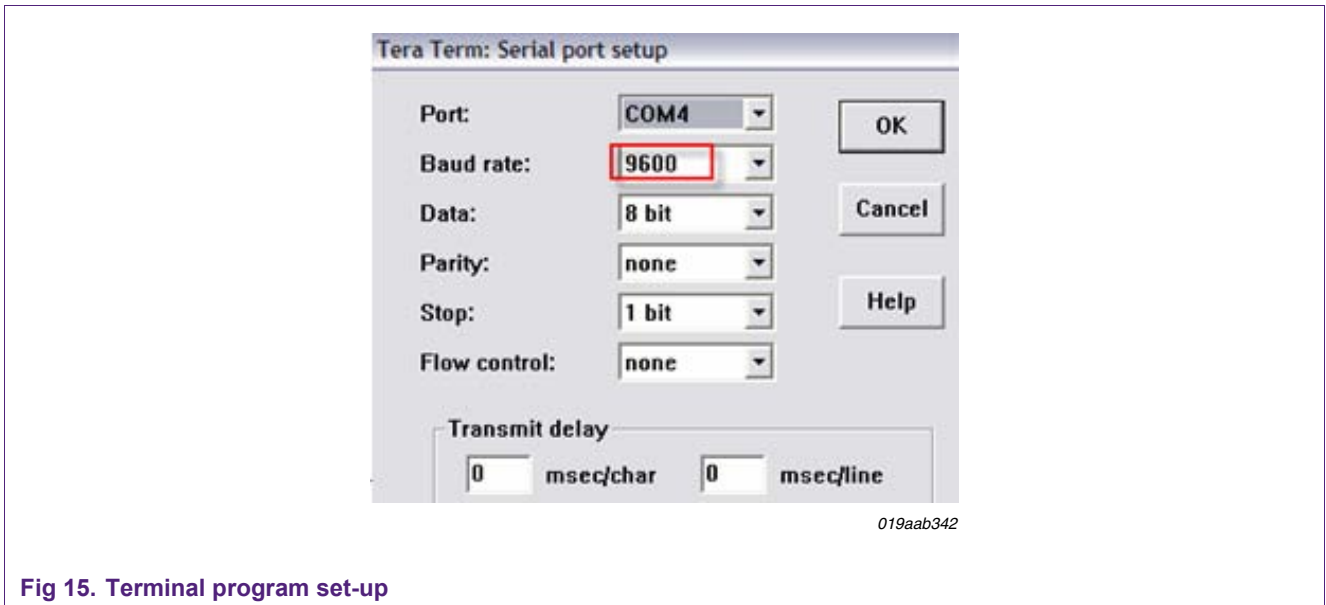

Fig 15. Terminal program set-up

- 13. Hit RESET button.
- 14. The output of the code is shown in Fig 16. The menu below shows how to enter the three low power modes (use lower case to enter modes).

```

ENTER WHICH MODE YOU WANT TO ENTER - LPC1300
SLEEP mode
  'a' - IRC <12MHz>
  'b' - System Oscillator <12MHz>
  'c' - System Oscillator with PLL <72MHz>

DEEP SLEEP mode
  'd' - All OFF

DEEP POWER DOWN mode
  'e' - Enter DEEP POWER DOWN

Option: █
    
```

019aab343

Fig 16. Low power mode demo

15. To wake up the device:
  - a. Press 'BL\_EN' push button to exit sleep and deep-sleep modes.
  - b. Press WAKEUP push button to exit deep power-down mode.
16. For Sleep and Deep Sleep modes, the wake-up times can be measured by using the following pins:
  - a. Trigger pin (PIO0\_2) - Used to get the device out of the sleep mode or deep-sleep mode. The pin is triggered externally (falling edge) to wake the device up using an external push button.
  - b. Strobe pin (PIO2\_0) - After wake-up, the device returns into run mode, and this pin is set high within the WAKEUP\_IRQHANDLER() subroutine.
17. As shown in [Fig 17](#), the wakeup time is the difference between the falling edge of the trigger pin (yellow waveform) and the rising edge of the Strobe pin (green waveform).

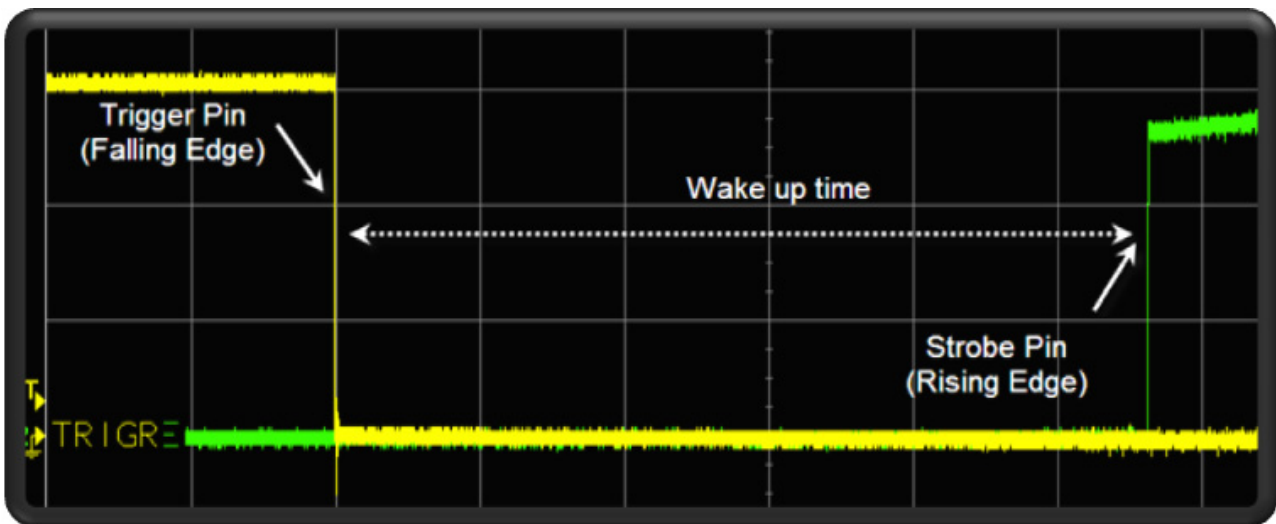

019aab344

Fig 17. Low power mode demo



#### 4.2.1.6 Power measurements and Wake-Up measurements using Demo 1

[Table 1](#) shows the typical power consumption and wake-up measurements using demo 1.

**Table 1. Typical power consumption (3.3 V, Temp = 25 °C)**

Low power modes	Ivdd current	Wake-up
Sleep mode (IRC (12 MHz), all peripherals off)	2 mA	2.9 us
Sleep mode (System Osc (12 MHz), all peripherals off)	2 mA	2.9 us
Sleep mode (System Osc with PLL enabled (72 MHz), all peripherals off)	9 mA	500 ns
Deep-sleep Mode (Watchdog Osc off and BOD off)	27 uA	23.6 μs
Deep Power-down Mode (note 1)	220 nA	240 μs

Note 1: Wake-up from deep power-down behaves like a chip reset. Demos provided with this application note are not readily set-up to measure the wake-up time for deep power-down mode. Using demo 1, user can set the strobe pin to be high in the reset handler (See the `cr_startup_lpc13.c` source file). The time between when the `WAKEUP` pin is triggered (goes low) and when the strobe pin goes high in the reset handler is the wake-up time for deep power-down mode.

#### 4.2.1.7 LPCXpresso Application Set-up for Demo 2

As mentioned before, demo 2 configures the watchdog oscillator at lowest frequency to clock the 16-bit Timer 0 in run and deep sleep modes. The device generates a repetitive self wake-up from deep-sleep mode and toggles a port pin when in run mode.

Application is set-up as follows:

1. Connect the USB cable to power up the LPCXpresso target board.
2. Open LPCXpresso IDE and import LPC1300 self wakeup.zip file
3. Build the project by selecting the Build 'all projects' (Debug)
4. Download the code by selecting the Debug 'wake-up' (Debug)
5. Then terminate the debug session once code is downloaded.
6. Power cycle the LPCXpresso target board.
7. The wake-up time can be measured by using the following pins:
  - a. Trigger pin (PIO0\_8/CT16B0\_MAT0) – Timer Output to get the device out of the deep-sleep mode.
  - b. Strobe pin (PIO0\_7) – After wake-up, the device returns into run mode, and this pin is toggles 4 times within the `WAKEUP_IRQHANDLER()` subroutine.
8. [Fig 18](#) shows the waveform output of the Timer match output and GPIO pin.

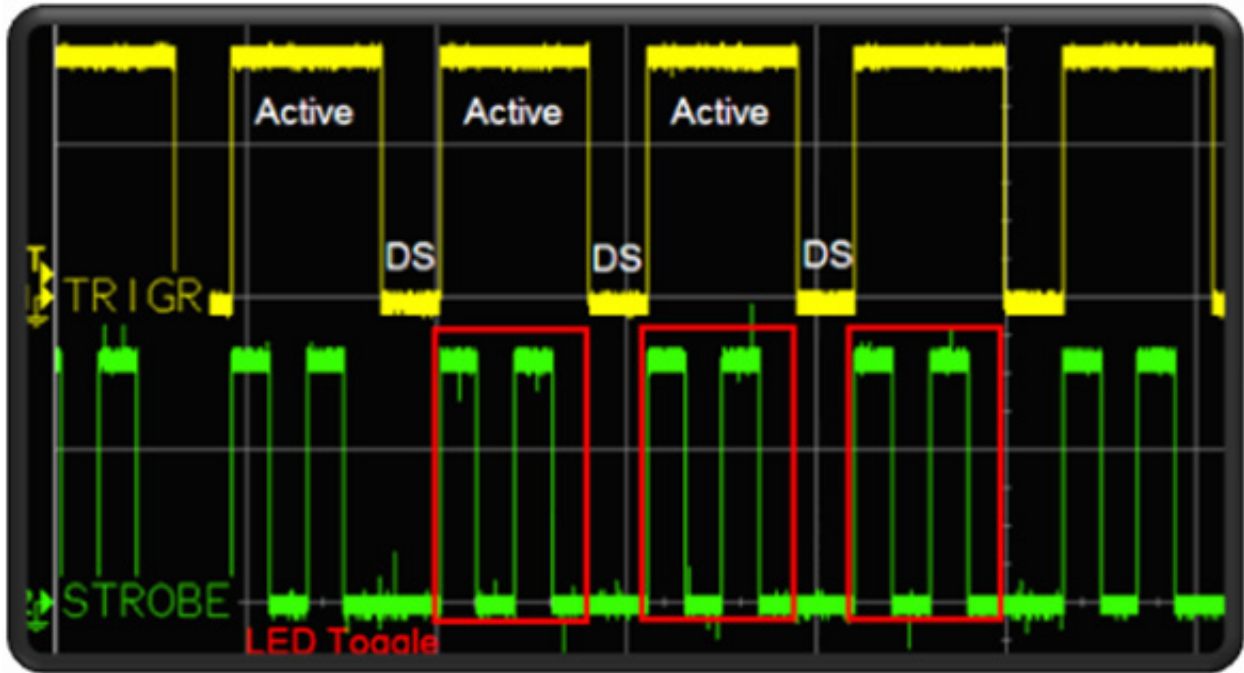

**1) Active Mode**

$I_{vdd} = \sim 1.3 \text{ mA}$  when GPIO pin (strobe) goes high  
 $I_{vdd} = \sim 560 \text{ uA}$  when GPIO pin (strobe) goes low

**2) Deep Sleep (DS)**

$I_{vdd} = \sim 27 \text{ uA}$

019aab345

Fig 18. Low power mode self-wakeup demo

9. As shown in Fig 19, the wakeup time is the difference between the rising edge of the trigger pin and the first falling edge of the Strobe pin.

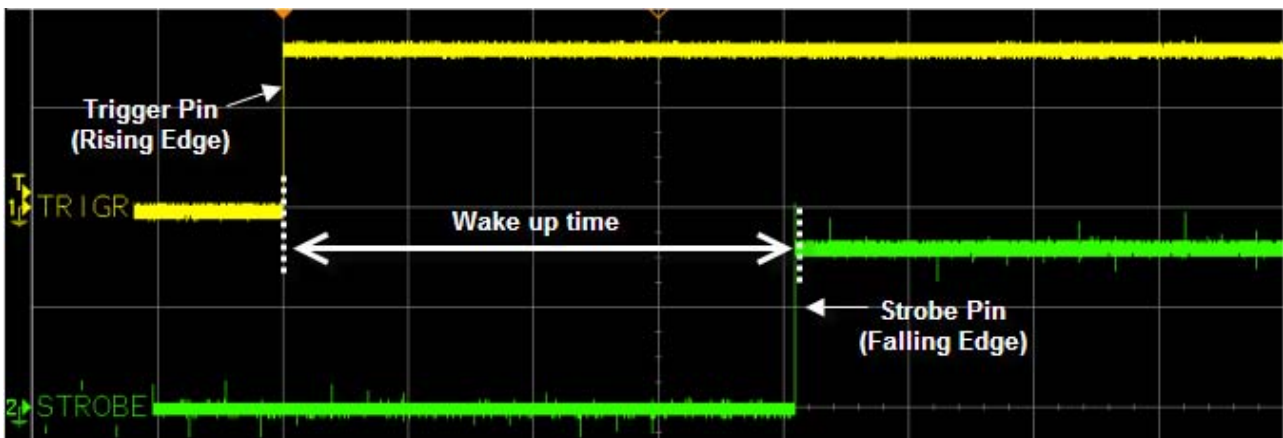

019aab346

Fig 19. Low power mode self-wakeup demo

10. Please note that once the code for demo 2 is downloaded, the device enters and exits deep-sleep mode on a repetitive basis. User must put the device first in ISP mode to erase or re-program the flash. See the LPC13xx User Manual for details on how to enter ISP mode.

#### 4.2.1.8 Power measurements and Wake-Up Measurements using Demo 2

[Table 2](#) shows the typical power consumption and self wake-up measurements using demo 2.

**Table 2. Typical power consumption (3.3 V, Temp = 25 °C)**

Low power modes	lvdd current	Wake-up
Deep-Sleep mode (Watchdog Oscillator (8.8 kHz) enabled, 16-bit Timer 0 on, BOD off)	27 $\mu$ A	5.0 ms

## 5. Conclusion

In conclusion, the LPC1300 provides great flexibility and various options for users to achieve low power consumption and wake-up flexibility. As shown in [Table 1](#), the user has various low power mode options to choose from in order to achieve the desired power consumption by trading up or down wake-up time of the device. This flexibility allows a trade-off between power consumption and wake-up speed based on the user's application requirements.

In addition, user has the option of using the self wake-up feature and would not require an external component to wake the device up from deep sleep mode. With the self wake-up feature, user can still achieve low power consumption but the trade off will be a longer wake-up time as shown in [Table 2](#). To achieve a faster wake-up time for deep-sleep mode, the user will need an external event trigger, switch the clock source to IRC before going into deep sleep mode and turn the Watchdog Oscillator off in deep-sleep mode.

## 6. Legal information

### 6.1 Definitions

**Draft** — The document is a draft version only. The content is still under internal review and subject to formal approval, which may result in modifications or additions. NXP Semiconductors does not give any representations or warranties as to the accuracy or completeness of information included herein and shall have no liability for the consequences of use of such information.

### 6.2 Disclaimers

**Limited warranty and liability** — Information in this document is believed to be accurate and reliable. However, NXP Semiconductors does not give any representations or warranties, expressed or implied, as to the accuracy or completeness of such information and shall have no liability for the consequences of use of such information.

In no event shall NXP Semiconductors be liable for any indirect, incidental, punitive, special or consequential damages (including - without limitation - lost profits, lost savings, business interruption, costs related to the removal or replacement of any products or rework charges) whether or not such damages are based on tort (including negligence), warranty, breach of contract or any other legal theory.

Notwithstanding any damages that customer might incur for any reason whatsoever, NXP Semiconductors' aggregate and cumulative liability towards customer for the products described herein shall be limited in accordance with the Terms and conditions of commercial sale of NXP Semiconductors.

**Right to make changes** — NXP Semiconductors reserves the right to make changes to information published in this document, including without limitation specifications and product descriptions, at any time and without notice. This document supersedes and replaces all information supplied prior to the publication hereof.

**Suitability for use** — NXP Semiconductors products are not designed, authorized or warranted to be suitable for use in life support, life-critical or safety-critical systems or equipment, nor in applications where failure or malfunction of an NXP Semiconductors product can reasonably be expected to result in personal injury, death or severe property or environmental damage. NXP Semiconductors accepts no liability for inclusion and/or use of

NXP Semiconductors products in such equipment or applications and therefore such inclusion and/or use is at the customer's own risk.

**Applications** — Applications that are described herein for any of these products are for illustrative purposes only. NXP Semiconductors makes no representation or warranty that such applications will be suitable for the specified use without further testing or modification.

Customers are responsible for the design and operation of their applications and products using NXP Semiconductors products, and NXP Semiconductors accepts no liability for any assistance with applications or customer product design. It is customer's sole responsibility to determine whether the NXP Semiconductors product is suitable and fit for the customer's applications and products planned, as well as for the planned application and use of customer's third party customer(s). Customers should provide appropriate design and operating safeguards to minimize the risks associated with their applications and products.

NXP Semiconductors does not accept any liability related to any default, damage, costs or problem which is based on any weakness or default in the customer's applications or products, or the application or use by customer's third party customer(s). Customer is responsible for doing all necessary testing for the customer's applications and products using NXP Semiconductors products in order to avoid a default of the applications and the products or of the application or use by customer's third party customer(s). NXP does not accept any liability in this respect.

**Export control** — This document as well as the item(s) described herein may be subject to export control regulations. Export might require a prior authorization from national authorities.

### 6.3 Trademarks

Notice: All referenced brands, product names, service names and trademarks are property of their respective owners.

## 7. Contents

<b>1.</b>	<b>Introduction .....</b>	<b>3</b>	6.1	Definitions.....	26
<b>2.</b>	<b>Low power modes .....</b>	<b>4</b>	6.2	Disclaimers.....	26
2.1.1	Sleep mode .....	4	6.3	Trademarks .....	26
2.1.2	Deep-sleep mode .....	4	<b>7.</b>	<b>Contents .....</b>	<b>27</b>
2.1.3	Deep power-down mode .....	4			
<b>3.</b>	<b>Entering the low power modes .....</b>	<b>4</b>			
3.1	System Control Register (SCR) .....	4			
3.2	Power Control Register (PCON) .....	5			
3.3	Wait For Interrupt (WFI) instruction .....	6			
3.4	Programming steps to enter sleep mode .....	6			
3.5	Programming steps to enter Deep-sleep mode ..	7			
3.6	Programming steps to enter Deep power-down mode .....	9			
3.7	Wake-up implementation.....	10			
3.7.1.1	Wake-up from Sleep mode.....	10			
3.7.1.2	Wake-up from Deep-sleep mode .....	10			
3.7.1.3	Wake-up from Deep power-down mode.....	11			
3.8	Additional tips to reduce power consumption ...	12			
3.8.1.1	CPU clock rate .....	12			
3.9	System AHB Clock Control Register (AHBCLKCTRL) .....	14			
3.10	Peripheral clock dividers .....	14			
3.11	Power-down Configuration register (PDRUNCFG) .....	14			
3.12	Miscellaneous .....	14			
3.12.1	Software .....	14			
3.12.2	Port pins .....	14			
3.12.3	USB pins .....	15			
3.12.4	RESET_N/PIO0_0 pin.....	15			
3.12.5	Debug notes.....	15			
<b>4.</b>	<b>Low power mode demos.....</b>	<b>16</b>			
4.1	Objective .....	16			
4.2	LPCXpresso demonstrations.....	16			
4.2.1.1	Requirements .....	16			
4.2.1.2	Terminal window .....	16			
4.2.1.3	LPCXpresso target board (LPC1343) .....	17			
4.2.1.4	LPCXpresso Base Board .....	18			
4.2.1.5	LPCXpresso Application Set-up for Demo 1 ....	19			
4.2.1.6	Power measurements and Wake-Up measurements using Demo 1 .....	23			
4.2.1.7	LPCXpresso Application Set-up for Demo 2 ....	23			
4.2.1.8	Power measurements and Wake-Up Measurements using Demo 2 .....	25			
<b>5.</b>	<b>Conclusion.....</b>	<b>25</b>			
<b>6.</b>	<b>Legal information .....</b>	<b>26</b>			

---

Please be aware that important notices concerning this document and the product(s) described herein, have been included in the section 'Legal information'.

---

© NXP B.V. 2011.

All rights reserved.

For more information, please visit: <http://www.nxp.com>  
For sales office addresses, please send an email to:  
[salesaddresses@nxp.com](mailto:salesaddresses@nxp.com)

Date of release: 6 January 2011

Document identifier: AN10973