



# INSTALLATION & OPERATION MANUAL



## MODELS

200 NDNL	300 NDNL	700 NDNL	950 NDNL
200 CT	300 CT	700 CT	957 NDNL
250 PNDR	300 OC	725 NDNL	1600 NDNL

For additional information on Thermodyne Foodservice Products, Inc.,  
or to locate an authorized parts and service provider in your area,  
visit our website at [www.tdyne.com](http://www.tdyne.com)

Thermodyne Foodservice Products, Inc.  
4418 New Haven Avenue  
Fort Wayne, IN 46803

1-800-526-9182  
[www.tdyne.com](http://www.tdyne.com)

---

## IMPORTANT FOR YOUR SAFETY

### WARNING

IMPROPER INSTALLATION, ADJUSTMENT, ALTERATION, SERVICE OR MAINTENANCE CAN CAUSE PROPERTY DAMAGE, INJURY OR DEATH. READ THE INSTALLATION, OPERATING AND MAINTENANCE INSTRUCTIONS THOROUGHLY BEFORE INSTALLING OR SERVICING THIS EQUIPMENT. SERVICE WORK SHOULD BE PERFORMED BY A LICENSED PROFESSIONAL, QUALIFIED TO SERVICE AND REPAIR ELECTRIC FOOD SERVICE EQUIPMENT.

IN THE EVENT OF A POWER FAILURE,  
DO NOT ATTEMPT TO OPERATE THIS DEVICE.



### **CAUTION**

Models 200CT, 300CT, and 700CT have glass doors. Remove carton carefully.

---

# TABLE OF CONTENTS

IMPORTANT FOR YOUR SAFETY.....	2
INTRODUCTION .....	4
GENERAL .....	4
SPECIFICATIONS .....	4
UNPACKING.....	8
Thermodyne Damaged Goods Policy.....	8
INSTALLATION CODES AND STANDARDS .....	8
INSTALLATION.....	9
LOCATION.....	10
ELECTRICAL CONNECTION .....	10
OPERATION.....	11
CONTROLS AND INDICATORS.....	11
STARTUP .....	11
Setting Temperature.....	11
Preheating .....	12
Extended Shutdown.....	12
FLUID REPLENISHMENT.....	12
PRODUCT PANS AND COVERS.....	13
GENERAL .....	13
Dry Pan Without Pan Screen .....	13
Dry Pan With Pan Screen .....	13
Wet Pan With Pan Screen.....	13
Pans With “V” Rack.....	14
Removing Lids .....	14
CLEANING AND MAINTENANCE .....	15
WHEN TO CLEAN .....	15
HOW TO CLEAN .....	15
Cleaning Safeguards .....	15
Sterilizing Stainless Steel .....	15
Cleaning Heat Transfer Plates .....	15
Stainless Steel Cabinet.....	16
Door Gasket.....	16
CHANGING FLUID.....	16
TROUBLESHOOTING.....	18
SCHEMATIC DIAGRAMS.....	19
WARRANTY .....	20
HEAT TRANSFER FLUID MSDS .....	20

# INTRODUCTION

## GENERAL

Thermodyne cabinets are produced with quality workmanship and materials. Proper installation, operation and maintenance will result in many years of satisfactory performance. It is suggested that you thoroughly read this manual in its entirety and carefully follow all of the instructions provided.

The cabinets described in this manual are programmable for the desired holding temperature. The factory setting is 185° F unless otherwise specified. Each shelf in the cabinet maintains an exact temperature, allowing for extended holding times without sacrificing appearance or taste.

DIMENSIONS AND MAXIMUM TEMPERATURE								
Model	Ext. Width inches	Ext. Depth inches	Ext. Height inches	Int. Width inches	Int. Depth inches	Int. Height inches	Max Oper. Temp °F	Max Oper. Temp °C
200 NDNL	17.5	23.0	18.6	13.5	22.0	13.0	230	110
300 NDNL	17.5	23.0	25.9	13.5	22.0	20.3	230	110
700 NDNL	30.5	23.0	27.3	26.5	22.0	20.3	230	110
725 NDNL	30.5	23.0	28.5	26.5	22.0	21.5	230	110
950 NDNL	45.0	23.0	20.0	41.0	22.0	13.0	230	110
957 NDNL	45.0	23.0	27.25	41.0	22.0	20.3	230	110
1600 NDNL	17.5	33.0	61.8	13.5	22.0	49.6	230	110
200 CT	17.5	24.8	20.0	13.5	22.0	13.0	230	110
300 CT	17.5	24.8	27.3	13.5	22.0	20.3	230	110
700 CT	30.5	24.8	27.3	26.5	22.0	20.3	230	110
300 OC	59.0	13.5	14.6	55.0	12.5	9.0	230	110
250 PNDDT	21.3	20.0	33.3	17.3	19.0	27.6	230	110

WEIGHT		
Model	Net Weight lbs	Shipping Weight lbs
200 NDNL	102	155
300 NDNL	123	185
700 NDNL	173	233
725 NDNL	188	248
950 NDNL	170	310
957 NDNL	220	360
1600 NDNL	241	405
200 CT	103	160
300 CT	126	190
700 CT	189	265
300 OC	160	235
250 PNDDT	168	203

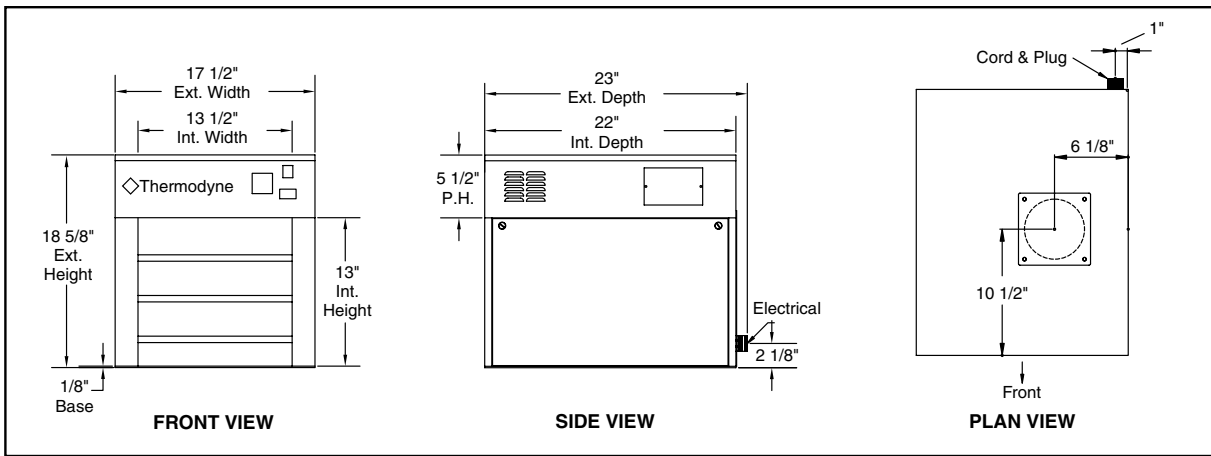

**Figure 1. Outline Dimensional Drawing, 200 NDNL**

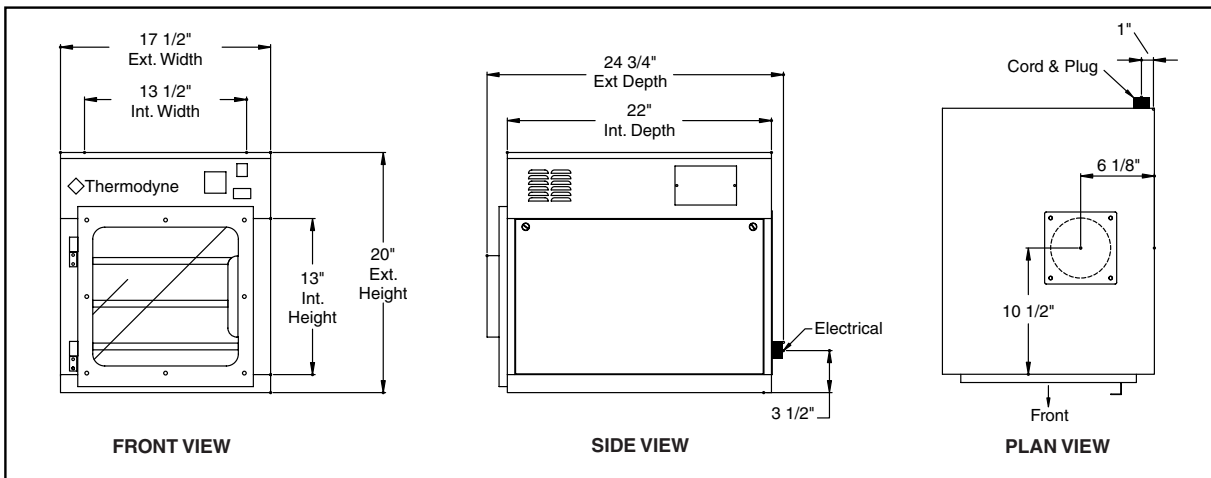

**Figure 2. Outline Dimensional Drawing, 200 CT**

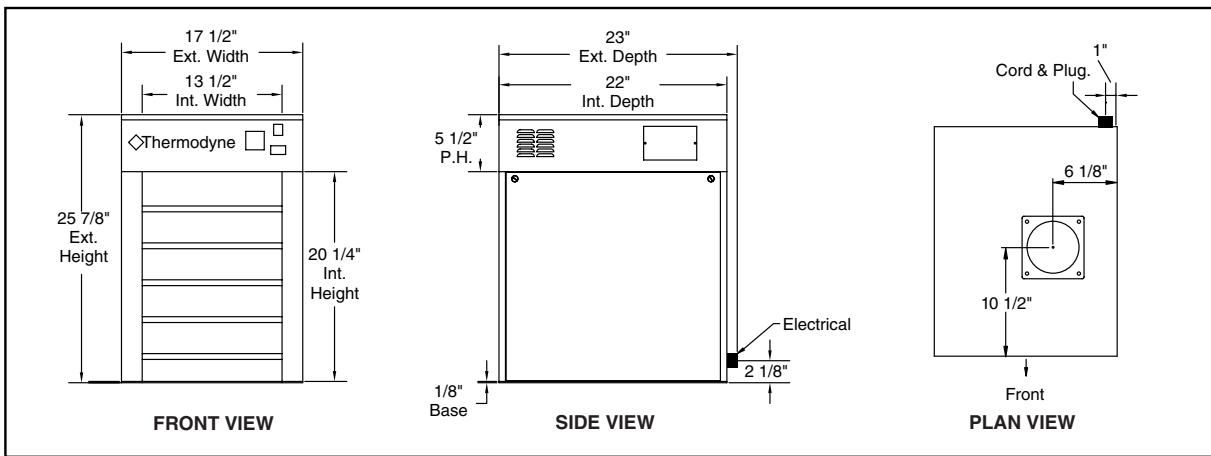

**Figure 3. Outline Dimensional Drawing, 300 NDNL**

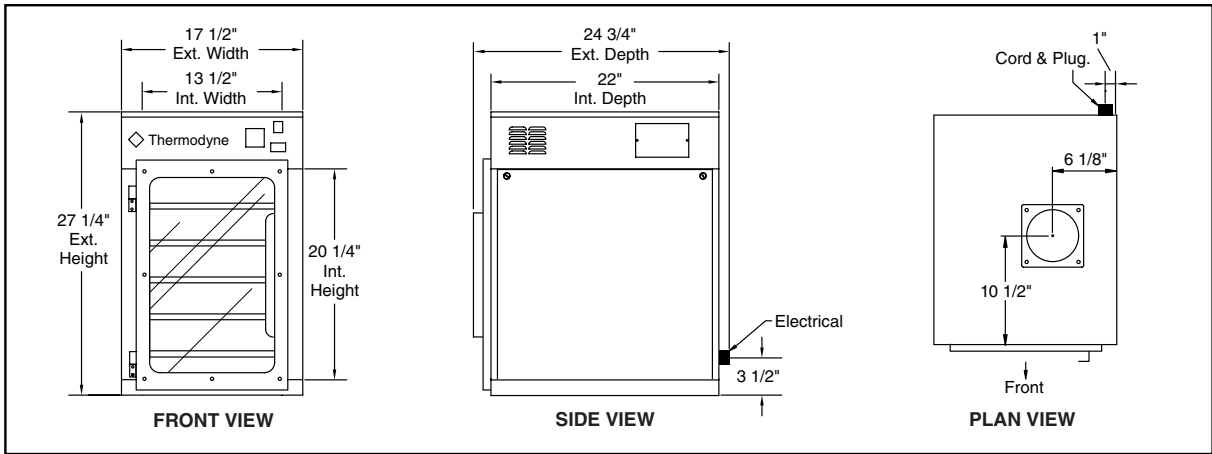

Figure 4. Outline Dimensional Drawing, 300 CT

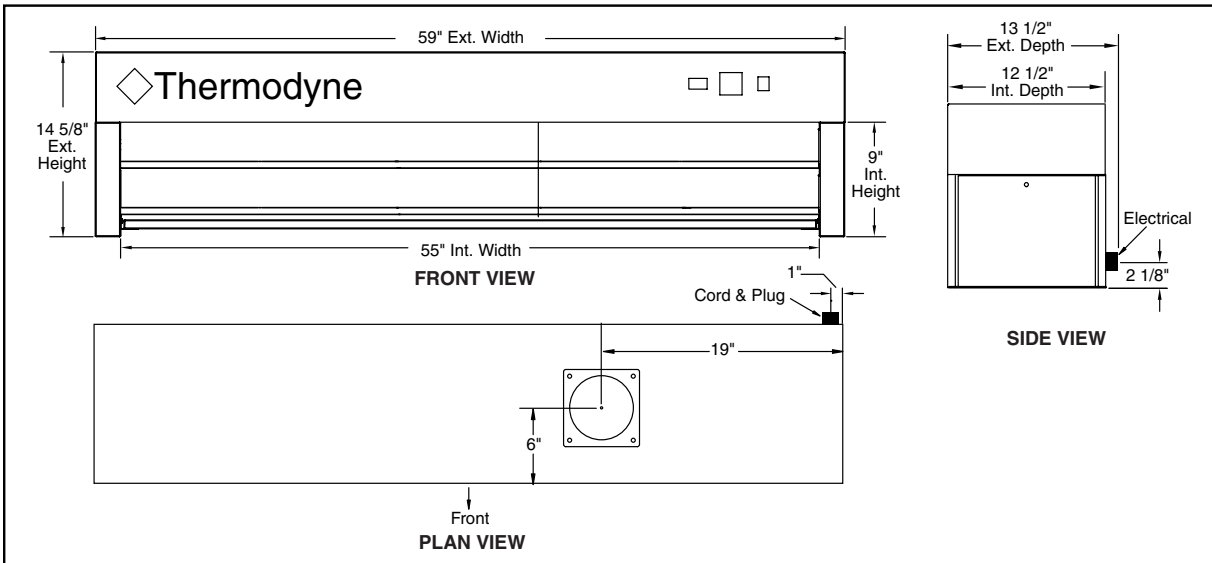

Figure 5. Outline Dimensional Drawing, 300 OC

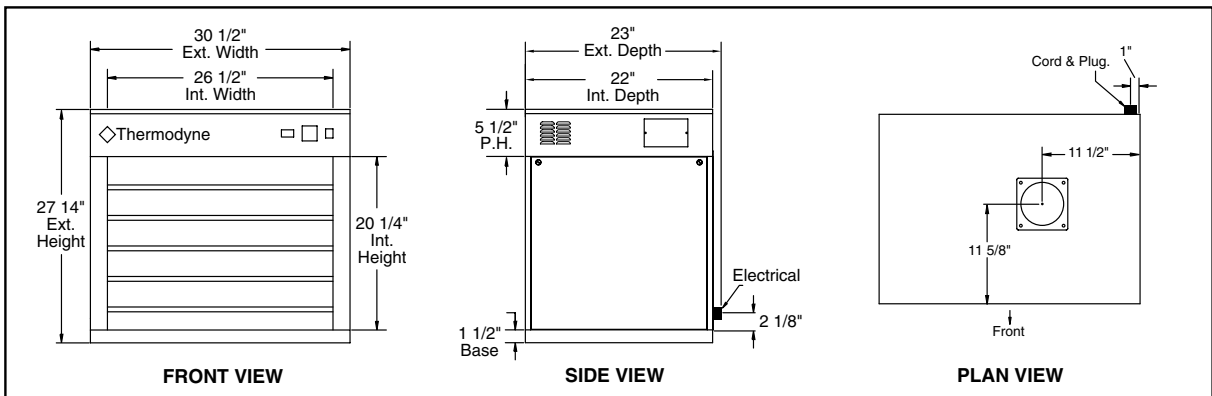
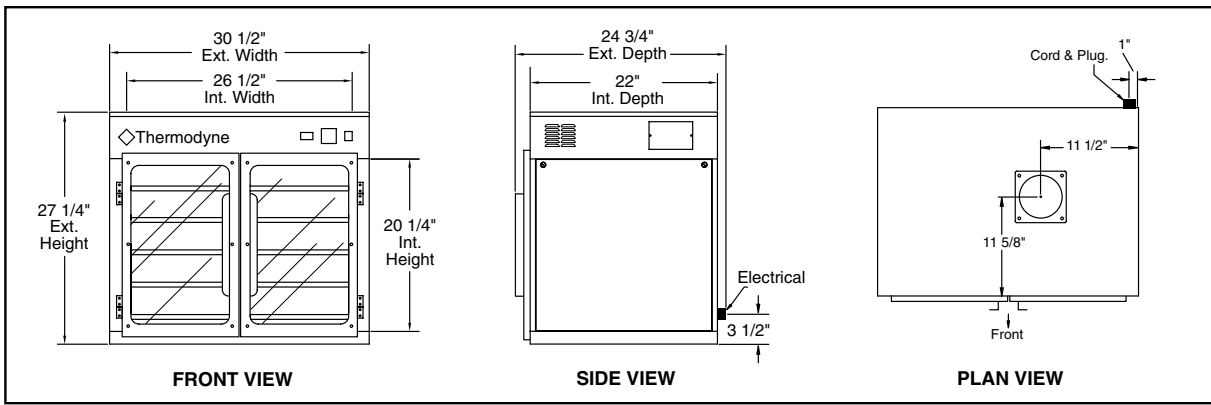
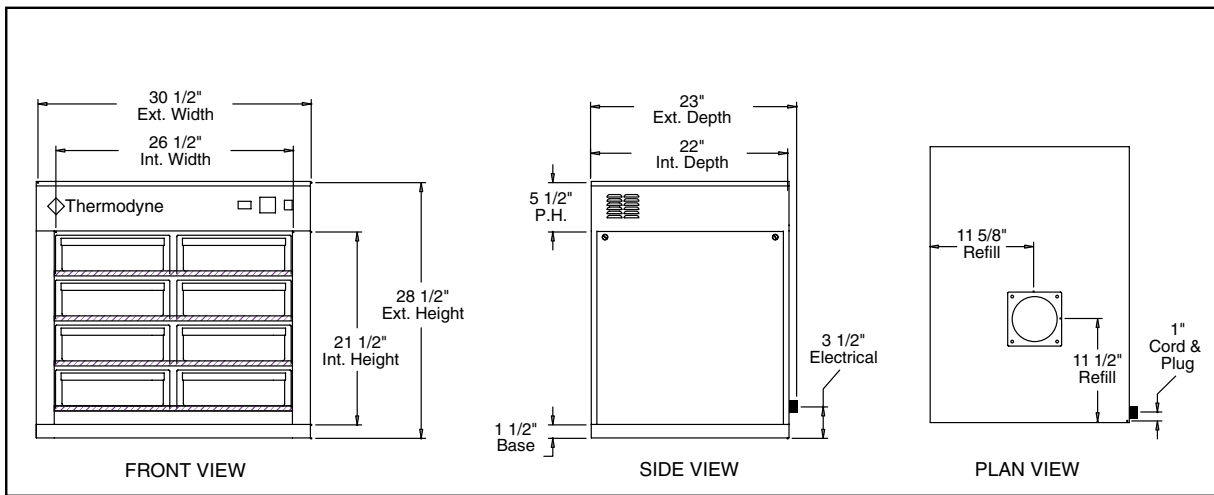

Figure 6. Outline Dimensional Drawing, 700 NDNL



**Figure 7. Outline Dimensional Drawing, 700CT**



**Figure 8. Outline Dimensional Drawing, 725 NDNL**

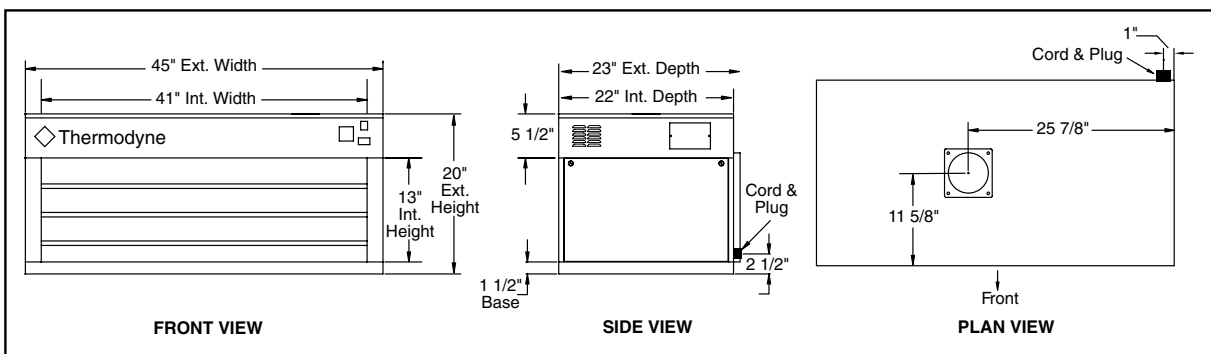

**Figure 9. Outline Dimensional Drawing, 950 NDNL**

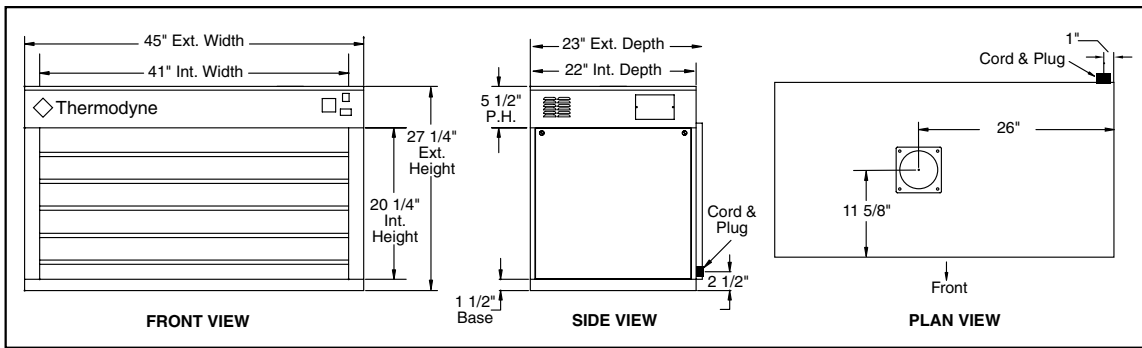

Figure 10. Outline Dimensional Drawing, 957 NDNL

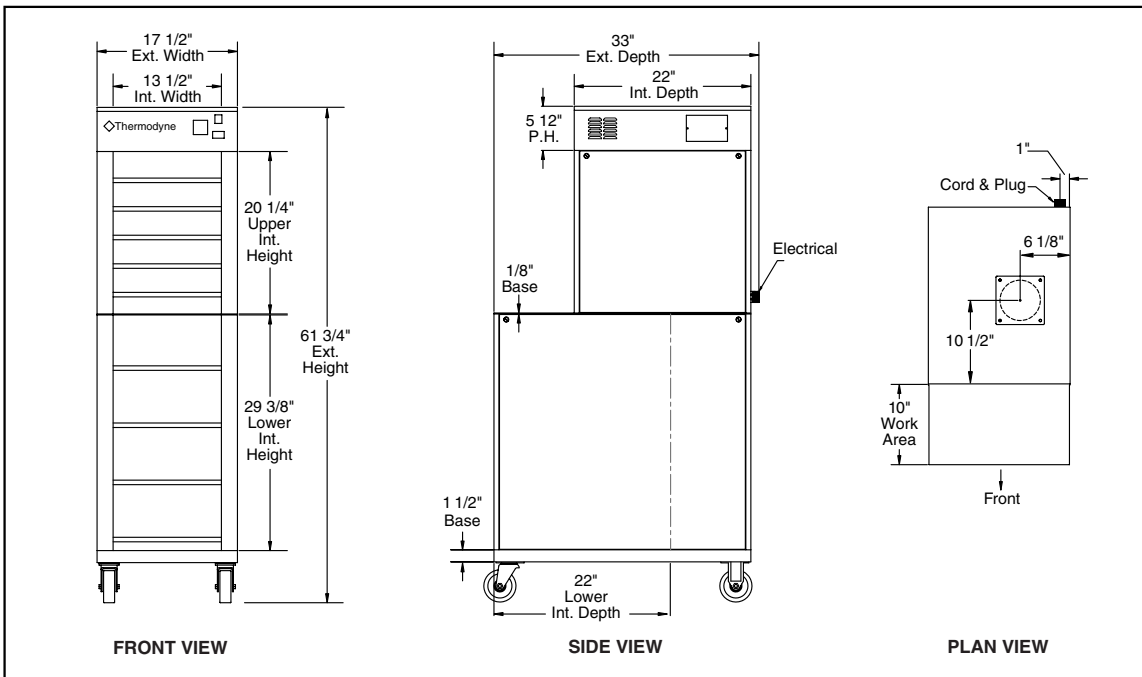

Figure 11. Outline Dimensional Drawing, 1600NDNL

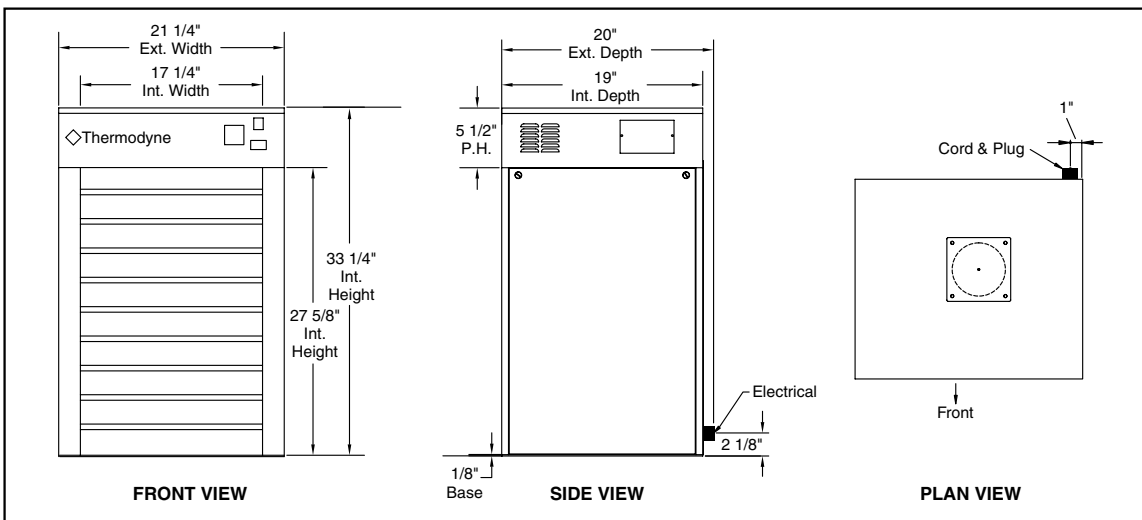

Figure 12. Outline Dimensional Drawing, 250PNDT



---

## UNPACKING

**NOTE:** All Thermodyne cabinets are factory tested for performance and certified free from defects.

### Thermodyne Damaged Goods Policy

There are two types of damaged merchandise: A. Visible Damage and B. Concealed Damage.

**A. Visible Damage:** The product being received is visibly damaged.

1. The receiver should refuse the damaged merchandise.
2. Receiver should sign the bill of lading indicating which merchandise is being refused due to damage.
3. Contact Thermodyne Customer Service Representatives immediately.

**B. Concealed Damage:** Damaged merchandise cannot be externally detected.

Your receiving operation should inspect for this type of damage. Please inspect your delivery carefully.

If the product is damaged:

1. Save all packing material.
2. Contact Thermodyne Customer Service Representatives immediately.
3. Receiver must call the carrier to schedule an inspection of the damaged merchandise within 5 business days.

## INSTALLATION CODES AND STANDARDS

In the United States, the Thermodyne cabinet must be installed in accordance with:

1. State and local codes.
2. National Electrical Code (ANSI/NFPA No. 70, latest edition) available from the National Fire Protection Association, Batterymarch Park, Quincy, MA 02269.

In Canada, the cabinet must be installed in accordance with:

1. Local codes.
2. Canadian Electrical Code (CSA C22.2 No. 3, latest edition) available from the Canadian Standards Association, 5060 Spectrum Way, Mississauga, Ontario, Canada L4W 5N6.

## INSTALLATION

Before installing, verify the required electrical supply agrees with the specifications on the data plate located on the back or side of the unit. If the supply and equipment requirements do not agree, do not proceed with installation. Contact your dealer or Thermodyne Foodservice Products, Inc. immediately.

**NOTE:** This unit is shipped pre-wired for 120 VAC or 208 VAC (60 Hertz), single phase operation.



### CAUTION

**Models 200CT, 300CT, and 700CT have glass doors. Remove carton carefully.**



### CAUTION

**Packaging may have sharp edges and banding; leather work gloves and safety glasses are recommended for safe unpacking.**

1. Allow ample overhead clearance for removal of carton.
2. Cut banding (2 pieces) and remove nails (not for all units).
3. To remove cabinet from carton, slide carton up and off the cabinet.
4. Check packing list against items received:
  - A. Thermodyne Heat Transfer Fluid.
  - B. Installation & Operation Manual
5. Use proper lifting equipment to raise the cabinet.

6. Remove the plastic covering from glass door frames and hinges. Mount doors on cabinet, then check doors for alignment (on certain models).
7. Set cabinet on a level surface.

### LOCATION

Allow adequate space for electrical connections. The electrical cord and plug are located at the right rear of the unit. The minimum clearance for proper air circulation on back should be 4", and 2" on at least one side. Allow adequate access space for operating and servicing the unit.

**NOTICE; Louvers on the sides of the oven are used to circulate cool air throughout the electrical components. The unit must not be placed where extensive airborne grease is present, such as near deep fryers or griddles.**

### ELECTRICAL CONNECTION



#### WARNING

ELECTRICAL AND GROUNDING CONNECTIONS MUST COMPLY WITH APPLICABLE PORTIONS OF THE NATIONAL ELECTRICAL CODE AND/OR OTHER LOCAL ELECTRICAL CODES.



#### WARNING

DISCONNECT THE ELECTRICAL POWER TO THE THERMODYNE UNIT AND FOLLOW LOCKOUT/TAGOUT PROCEDURES.

Refer to the wiring diagrams in this manual for wiring information.

Model	Volts	Hertz	Phase	Watts	Amps	Plug Type US
200 NDNL	120	60	1	1750	15	NEMA 5-15P
300 NDNL	120	60	1	1750	15	NEMA 5-15P
700 NDNL	208/240	60	1	5250/7000	25/29	NEMA L14-30
725 NDNL	208/240	60	1	5250/7000	25/29	NEMA L14-30
950 NDNL	208/240	60	1	5250/7000	25/29	NEMA L14-30
957 NDNL	208/240	60	1	5250/7000	25/29	NEMA L14-30
1600 NDNL	208/240	60	1	5250/7000	25/29	NEMA L14-30
200 CT	120	60	1	1750	15	NEMA 5-15P
300 CT	120	60	1	1750	15	NEMA 5-15P
700 CT	208/240	60	1	5250/7000	25/29	NEMA L14-30
300 OC	120	60	1	1750	15	NEMA 5-15P
250 PNDDT	208/240	60	1	5250/7000	25/29	NEMA L14-30

# OPERATION

## CONTROLS AND INDICATORS

All controls are located at the top right front of the Thermodyne cabinet.

ITEM	FUNCTION
<b>ON/OFF Switch</b>	When lit, it indicates the unit is turned on.
<b>ADD FLUID Light (Red)</b>	When lit, it indicates additional fluid is required.
<b>Controller</b>	Provides readout of actual temperature and desired temperature. It has up and down buttons for setting the desired temperature. In addition, a red out light blinks indicating the desired temperature is being maintained.

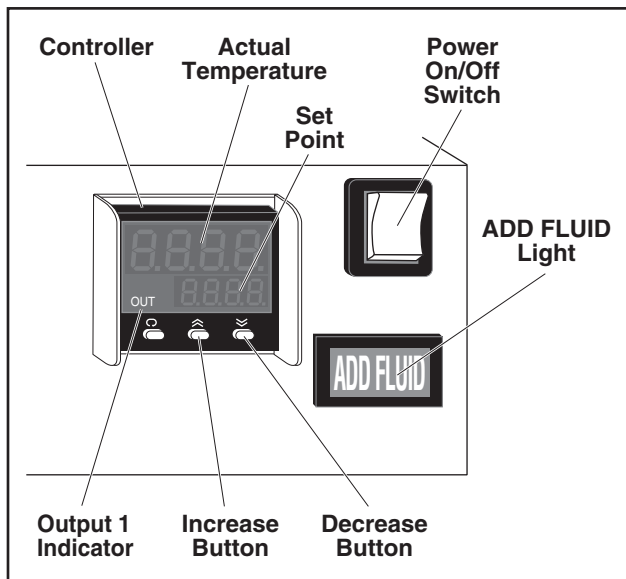

Figure 13. Control Panel

## STARTUP



### WARNING

THE THERMODYNE CABINET AND ITS PARTS ARE HOT. USE CARE WHEN OPERATING, CLEANING, OR SERVICING THE CABINET.

Once the cabinet is installed and electrical connections have been made, thoroughly test the Thermodyne cabinet before operation.



1. Check that all packing materials and other items have been removed from the cabinet.
2. Press the Power ON/OFF Switch to the ON position. The operating temperature will be reached in approximately 30 minutes.
3. Check ADD FLUID Light. If the light remains on or flickers continuously, it indicates that some fluid was lost during shipment. Add fluid as described in the section **FLUID REPLENISHMENT**.

**NOTE:** The controller has an out light (red lamp). This light blinks as the controller maintains the Thermodyne Heat Transfer Fluid at the desired temperature.

Size, weight, pan loading, and product quality will affect cooking times and should be adjusted to fit the requirements of your operation.

### Setting Temperature

1. To set temperature:

KEY	FUNCTION
Up Key 	Press and release quickly to increase the value of the displayed parameter. Press and hold to accelerate increment speed.
Down Key 	Press and release quickly to decrease the value of the displayed parameter. Press and hold to accelerate decrement speed.

2. OUT button will illuminate while cabinet is warming up.
3. When OUT button is blinking, the cabinet has reached the desired temperature.

**NOTE:** THIS CONTROLLER IS NOT AN INDICATOR OF FLUID LEVEL IN THE HEATER OR RESERVOIR TANK.

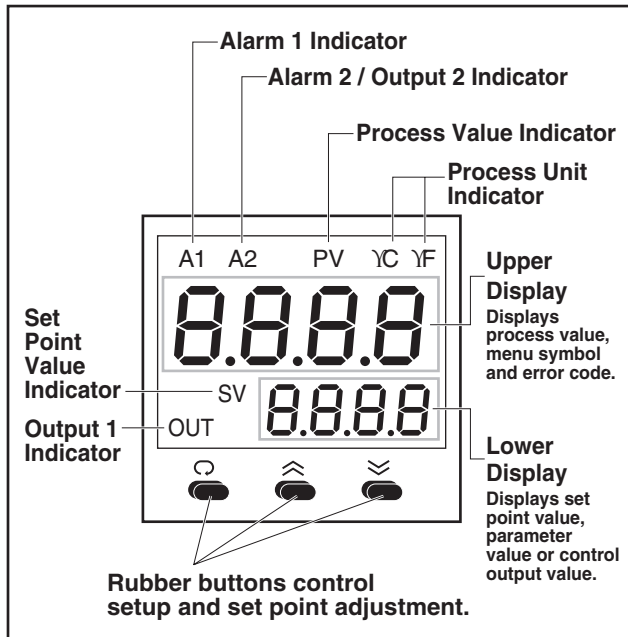

**Figure 14. Control Panel**

### Preheating

Preheat the Thermodyne cabinet when first used for the day or whenever the unit is cold. Preheating takes approximately 30 minutes at which time the temperature set point and the actual temperature will display the same temperature. If the cabinet has door(s), keep the doors closed during the preheat cycle.

### Extended Shutdown

1. Press Power ON/OFF Switch to OFF position.
2. Clean pans and shelves.

### FLUID REPLENISHMENT



#### CAUTION

Use only supplied Thermodyne Heat Transfer Fluid.

1. Remove the 4 screws securing the fill cap cover and remove cover.
2. Remove the reservoir tank cap.
3. Fill reservoir tank until ADD FLUID light turns off.
4. Re-install the reservoir tank cap and fill cap cover.

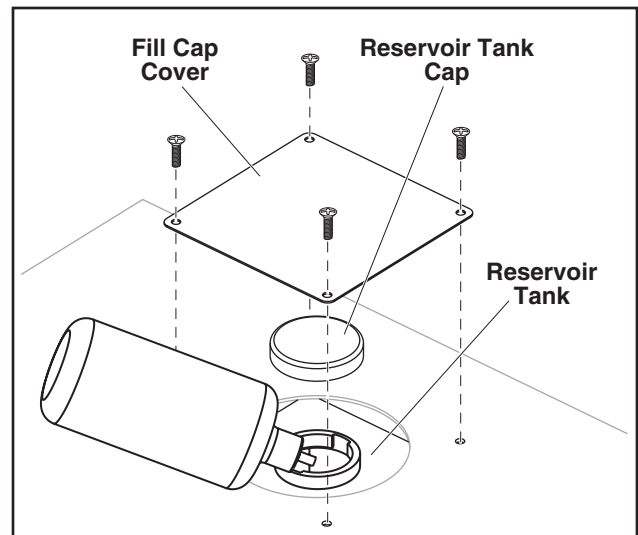

**Figure 15. Reservoir Tank Replenishment**

**NOTE:** If the ADD FLUID Light remains on after the Thermodyne unit has been filled, refer to TROUBLESHOOTING.

---

# PRODUCT PANS AND COVERS

## GENERAL

**NOTE:** Food products can be held dry, moist, assembled, and wrapped.

### Dry Pan Without Pan Screen

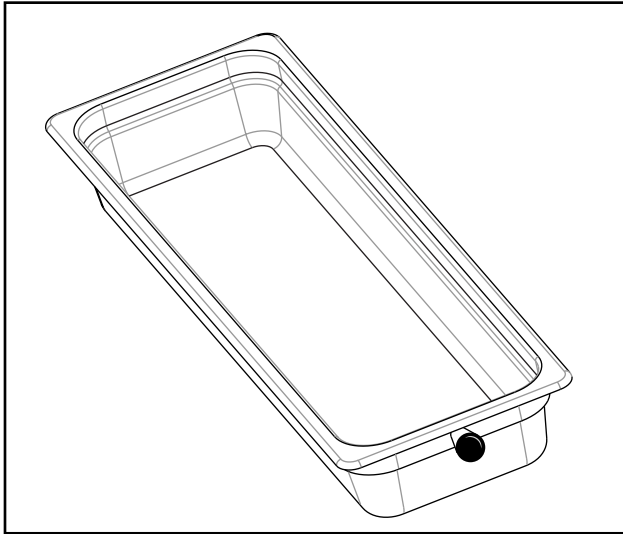

**Figure 16. Dry Pan Without Pan Screen**

Used for products with high moisture, such as:

- Sauces
- Gravies
- Casseroles
- All products with fast turnover
- Breaded Products – Vented/No Moisture
- Ribs and Riblets
- Potatoes
- Scrambled Eggs
- Vegetables

For crispier products, hold uncovered or vented. Uncovered product should have an optional solid back.

### Dry Pan With Pan Screen

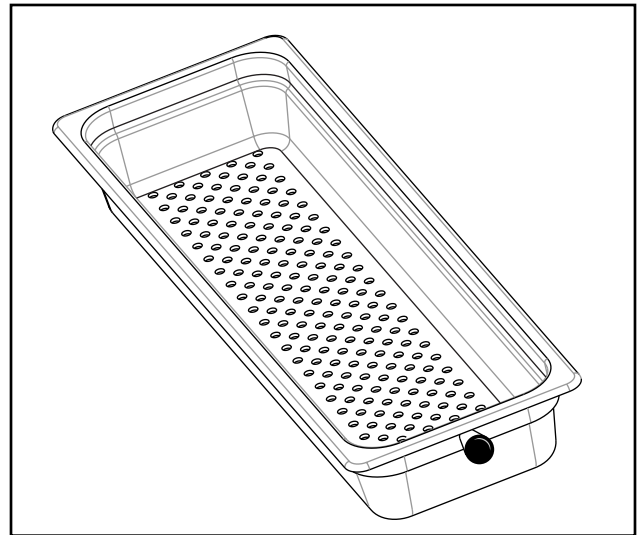

**Figure 17. Dry Pan With Pan Screen**

Used for dry and crisp products. Ideal for products with high oil content, such as:

- Bacon
- Hot Dogs
- Hamburger Patties
- Breaded Chicken Patties
- Biscuits
- English Muffins
- Fried Fish
- Fried Chicken – Vented or No Cover
- Fried Sandwiches – Vented or No Cover
- French Toast

### Wet Pan With Pan Screen

Insert stainless steel insert rack; pour in water prior to adding food product. Water will typically last for several hours, but will vary by temperature setting. Never allow water to sit overnight.



**Figure 18. Wet Pan With Pan Screen**

Used for products susceptible to drying, such as:

- Grilled Chicken Breast
- Egg Products for Sandwiches, Sausage Links, and Patties
- Hamburger Patties (extended holding)
- Bagels
- Pancakes
- Assembled Wrapped Sandwiches

**Pans With “V” Rack**

Water can be added to the bottom of the pan for moisture.

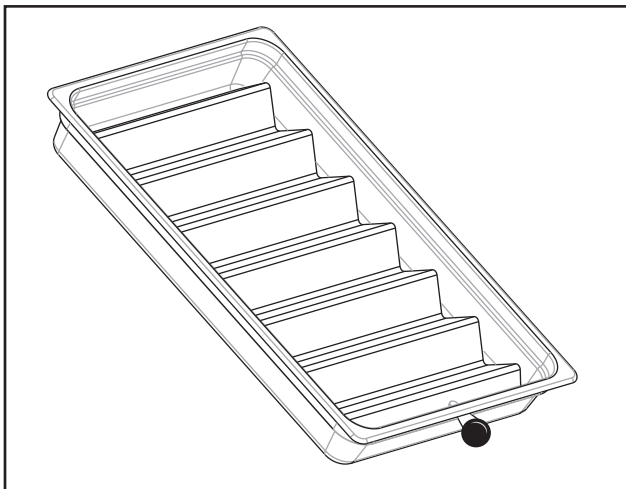

**Figure 19. Pans With “V” Rack**

Used for products such as:

- Tacos
- Burritos
- Assembled Hot Dogs
- Small Wrapped Sandwiches
- Hot Spring Rolls

**Removing Lids**



**CAUTION**

Lid may be extremely hot.



**CAUTION**

Handle with care; lids may have sharp edges.

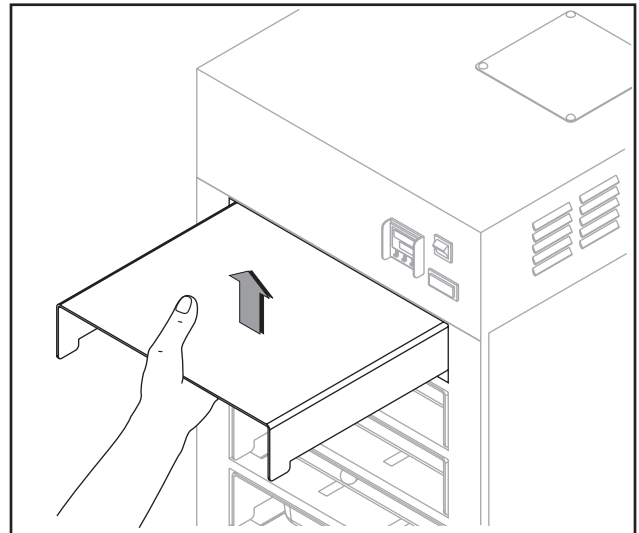

**Figure 20. Removable Lid**

1. Remove lid by taking out the pans and lifting up on the metal lid. Lids can then be cleaned and sanitized.
2. When changing pans to different food products, lids should be cleaned to avoid cross contamination of food product or migration of flavors.



---

# CLEANING AND MAINTENANCE



## **WARNING**

DISCONNECT ELECTRICAL POWER TO THE THERMODYNE UNIT AND FOLLOW LOCKOUT/TAGOUT PROCEDURES BEFORE CLEANING.



## **CAUTION**

**Stainless steel lids may have sharp edges; handle with extreme care while cleaning.**

## **WHEN TO CLEAN**

It is recommended that all stainless steel equipment be cleaned on a regular basis. Any piece of stainless steel equipment that is soiled should be cleaned daily to ensure the long life of the equipment. Routine cleaning will also lessen stainless steel abrasion.

## **HOW TO CLEAN**

To remove most soil, use a non-abrasive, non-chlorinated soap solution. Rinse thoroughly with warm water and wipe dry using an absorbent cloth. To remove heavy soil, rub the area with a non-metallic, fine-grain scouring cloth. Be sure to rub in the same direction as the metal grain. Rinse thoroughly with warm water and wipe using a soft absorbent cloth. As a final step, a stainless steel polish may be applied. The polish will shine the stainless steel and provide a protective finish to reduce future soiling.

## **Cleaning Safeguards**

1. Always rub in the direction of the metal grain. Never use steel wool or metallic scouring cloths. These two measures will help prevent scratching and possible damage to the surface finish.
2. Use the recommended dilution. Do not exceed concentration levels as this may cause long term deterioration of the surface. Be certain to rinse surface thoroughly to prevent buildup of cleanser.

3. Never use chlorine or bleach solutions. Check the ingredients of cleaning solutions or disinfectants used as they may contain chlorinated solvents.
4. Always read the label of the cleaning solutions. Check for warnings about use on stainless steel or aluminum products. Repeated use of chlorinated solvents may cause a chemical reaction with stainless steel or aluminum; resulting in damage to the surface and rusting.

## **Sterilizing Stainless Steel**

When sterilizing stainless steel equipment, pay particular attention to agents containing chlorine compounds such as potassium hypochlorite. These compounds may break down and release free chlorine or hydrolyze to form hydrochloric acid. Stainless steel can resist attack by the compounds for up to 2 hours. Severe localized pitting may occur with longer exposure. For safe use of the agents, keep contact time short, flush thoroughly with water, and operate equipment normally between applications. Using these precautions, the sterilization process can be repeated as often as necessary.

## **Cleaning Heat Transfer Plates**

The Thermodyne unit operates on the principle of conduction, rather than convection. Therefore, it is very important to keep the heat transfer shelves clean, so heat transfer may take place with maximum efficiency. It is also very important to keep the bottom contact surfaces of pots and pans as clean as possible to ensure even and complete heat transfer.

The surface and flat coating of the thermal heat transfer shelf is extremely hard, but will react with strong caustic cleaning solutions and deteriorate.



## **CAUTION**

**Most concentrated soaps and ammonia cleaners are too caustic to be used on the Thermodyne unit.**

---

If the coating is destroyed, the heat transfer shelves will lose their non-stick properties and their surface hardness.

The cleaners should always be used at the recommended concentrations. In the case of dry powders, the powders must not be placed directly on the surface of the heat transfer plate. Care must be taken not to scratch the shelf surfaces when using brushes or pads. If harsh scouring is needed, use a nylon type scouring pad. Never use steel wool.

It is recommended that a weekly cleaning schedule be followed to avoid the buildup of heavy food product deposits. In the event heavy deposits occur that are difficult to remove with ordinary cleaning procedures, stronger chemical cleaning agents may be applied if the products are intended for food service use and are also compatible with hard coat anodized aluminum surfaces. When using these stronger solvents, it is very important that heat transfer shelves are rinsed thoroughly with clean potable water after cleaning. Be sure to remove all traces of the cleaning agent. Between the regular scheduled cleaning, wipe off the anodized aluminum surfaces periodically with a clean damp cloth.

### **Stainless Steel Cabinet**

1. Any pot and pan detergent acceptable for food service cleaning and compatible with aluminum and stainless steel may be used on shelf and cabinet surfaces.
2. A #20 plastic bristled brush used with the appropriate detergent is acceptable for cleaning. It is very important when cleaning the heat transfer shelves that the undersides of the shelves are thoroughly cleaned also.
3. Hot water hose rinsing is preferred. If a hose is not available, rinsing with a sponge or cloth and clean hot water is acceptable. Be sure all surfaces are completely rinsed during the rinsing procedure. Do not allow water to come in contact with the Powerhead located on the top of the Thermodyne unit.
4. The glass doors can be cleaned with any commercial window-cleaning product, provided they are free of ammonia or chlorine and are food service compatible.

### **Door Gasket (CT Units)**

Clean the gasket-sealing surface of the Thermodyne doors to remove food product acids for maximum gasket life. Do not use any solvents or sharp instruments as these will damage the gasket. Wash with a cloth moistened in a solution of mild detergent and warm water. Rinse with a fresh cloth moistened with warm water to remove all traces of detergent.

Wipe dry with a clean cloth. Never apply food product oils or petroleum lubricants directly to the door gasket as these will reduce gasket life.

## **CHANGING FLUID**

**NOTE:** The Thermodyne Heat Transfer Fluid has lubricating additives, anticorrosion additives, and heat transfer properties that may decrease with the passing of time. Thermodyne Heat Transfer Fluid will protect the unit indefinitely if the fluid is changed on an annual basis.



### **CAUTION**

**The following procedure is to be performed by a qualified service technician only.**



### **WARNING**

**DISCONNECT THE ELECTRICAL POWER TO THE THERMODYNE UNIT AND FOLLOW LOCKOUT/TAGOUT PROCEDURES.**

1. Disconnect the unit from its power source and allow the unit to cool completely.
2. Remove the stainless steel panel covering the left side of the unit.
3. Remove the powerhead lid; 4 screws.



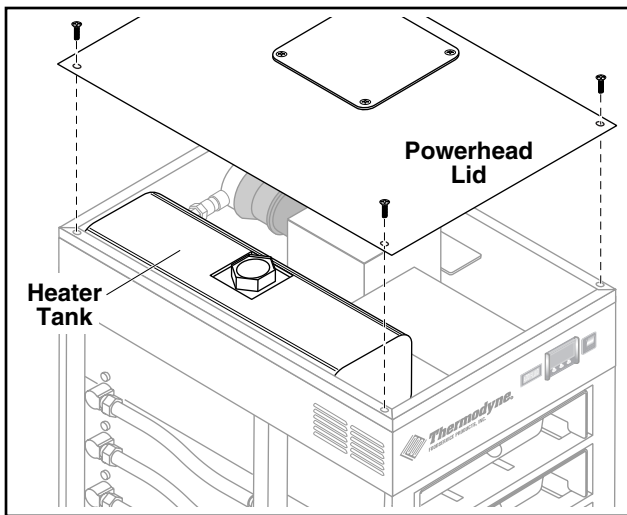

**Figure 21. Powerhead Lid**

4. Locate heater tank and remove cap.

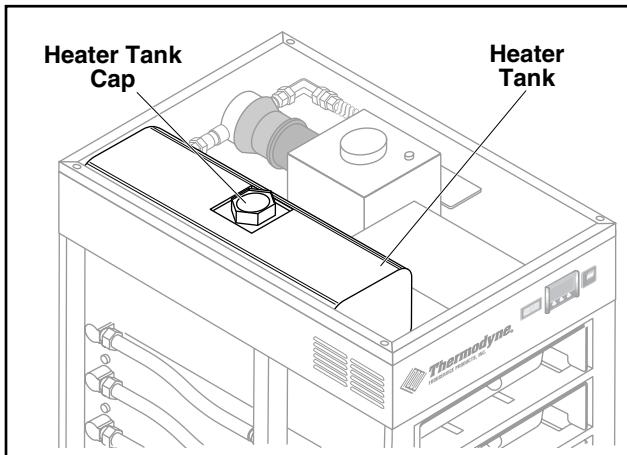

**Figure 22. Heater Tank Cap**

5. Place a pan or bucket beside drain plug in order to catch drained fluid.

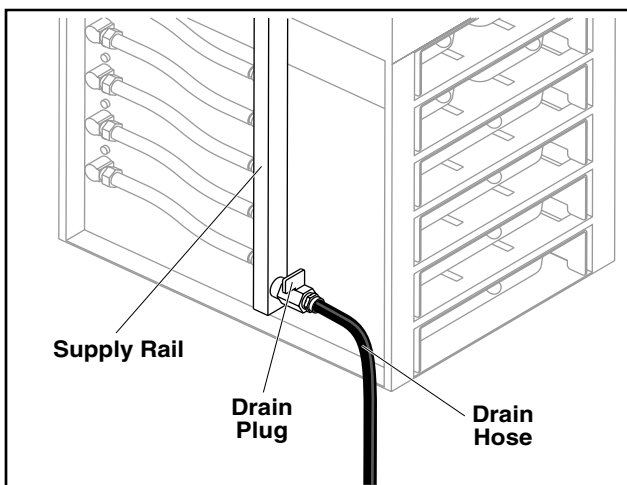

**Figure 23. Drain Hose**

6. Aim drain hose into pan or bucket and turn valve to open position.
7. Once oven has drained completely turn valve to off position and place drain hose back in cabinet.
8. Return stainless steel panel to left side.
9. Refill the unit with Thermodyne Heat Transfer Fluid only. Never substitute with water or other liquids.
10. Return heater tank cap.
11. Place lid back on, but do not tighten screws.
12. Plug unit in and turn on.
13. Unit will run briefly and shut off due to low fluid level.
14. Remove powerhead lid and heater tank cap and fill heater tank.

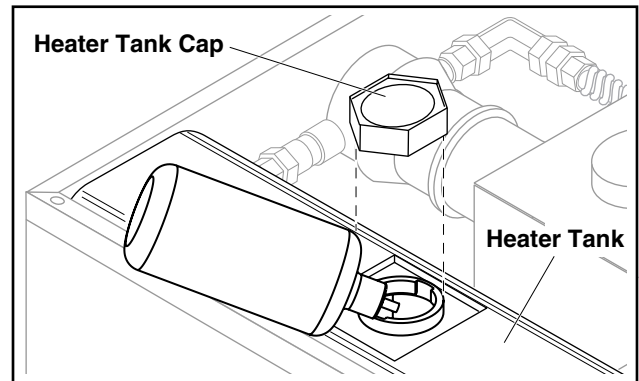

**Figure 24. Heater Tank Fill**

15. Repeat steps 11-15 until unit is completely full of fluid.
16. Once unit is completely filled, place powerhead lid back on unit and tighten screws snug.
17. If ADD FLUID light is on, add fluid to reservoir tank until light goes out.
18. Let unit run until maximum temperature is reached.
19. Once full temperature is reached, shut unit down and let it cool down to at least 100°F.
20. Turn unit back on, and if ADD FLUID light is on again, continue adding fluid to reservoir tank until light goes out.

**NOTE:** Steps 19 and 20 are very critical in order to purge oven from any air trapped in unit.

# TROUBLESHOOTING

Most problems associated with the holding unit are due to low fluid level. Always check fluid level first.

PROBLEM	POSSIBLE CAUSE	SOLUTION
No Power:	<ol style="list-style-type: none"> <li>1. Main power switch off.</li> <li>2. Not plugged in.</li> <li>3. Breaker off or tripped.</li> <li>4. Bad contactor.</li> </ol>	<ol style="list-style-type: none"> <li>1. Turn switch on.</li> <li>2. Check plug.</li> <li>3. Check breaker.</li> </ol>
LOW FLUID light is on - Oven heating properly:	<ol style="list-style-type: none"> <li>1. Oven is low on fluid.</li> </ol>	<ol style="list-style-type: none"> <li>1. Add Thermodyne Heat Transfer Fluid per instructions.</li> </ol>
LOW FLUID light is on - Oven not heating properly:	<ol style="list-style-type: none"> <li>1. Oven disabled due to low fluid level cut out.</li> <li>2. Fluid level probe defective.</li> <li>3. System leak.</li> </ol>	<ol style="list-style-type: none"> <li>1. Main heater tanks low on fluid. Add Thermodyne Heat Transfer Fluid and determine cause of fluid loss.</li> <li>2. Repair or replace.*</li> <li>3. Repair leak.*</li> </ol>
Heater(s) not working:	<ol style="list-style-type: none"> <li>1. Unit not properly wired.</li> <li>2. Bad heater(s).</li> <li>3. Contactor or solid state relays not working.</li> <li>4. Off due to low fluid cut out.</li> <li>5. Failed temperature controller.</li> <li>6. High limit snap disc tripped.</li> </ol>	<ol style="list-style-type: none"> <li>1. Check wiring.*</li> <li>2. Replace heater(s).*</li> <li>3. Repair or replace.*</li> <li>4. Add Thermodyne Heat Transfer Fluid per instructions.</li> <li>5. Replace temperature controller.*</li> <li>6. Reset snap disc and check for cause.*</li> </ol>
Shelves hotter than set point:	<ol style="list-style-type: none"> <li>1. Temperature controller out of calibration.</li> <li>2. Thermocouple defective.</li> <li>3. Solid state relay(s) stuck on.</li> <li>4. Failed temperature controller.</li> </ol>	<ol style="list-style-type: none"> <li>1. Recalibrate temperature controller.*</li> <li>2. Replace thermocouple.*</li> <li>3. Replace solid state relay(s).*</li> <li>4. Replace temperature controller.*</li> </ol>
Shelves colder than set point:	<ol style="list-style-type: none"> <li>1. Low fluid in tank. (LOW FLUID light should be lit)</li> <li>2. Failed temperature controller.</li> <li>3. Heater(s) not working.</li> <li>4. Pump failure.</li> <li>5. Thermocouple failure.</li> </ol>	<ol style="list-style-type: none"> <li>1. Add Thermodyne Heat Transfer Fluid per instructions.</li> <li>2. Replace temperature controller.*</li> <li>3. See "Heater(s) not working".</li> <li>4. Repair or replace pump.</li> </ol>
Oven heats up too slow:	<ol style="list-style-type: none"> <li>1. Heater(s) not working.</li> </ol>	<ol style="list-style-type: none"> <li>1. See "Heater(s) not working".</li> </ol>

\*Recommended to be done by a qualified service agency.

**NOTE:** Most problems associated with the Thermodyne cabinet are due to failure to add Thermodyne Heat Transfer Fluid. Check fluid level first. In the event service is required on your Thermodyne Oven, please call: (800) 526-9182.

# SCHEMATIC DIAGRAMS

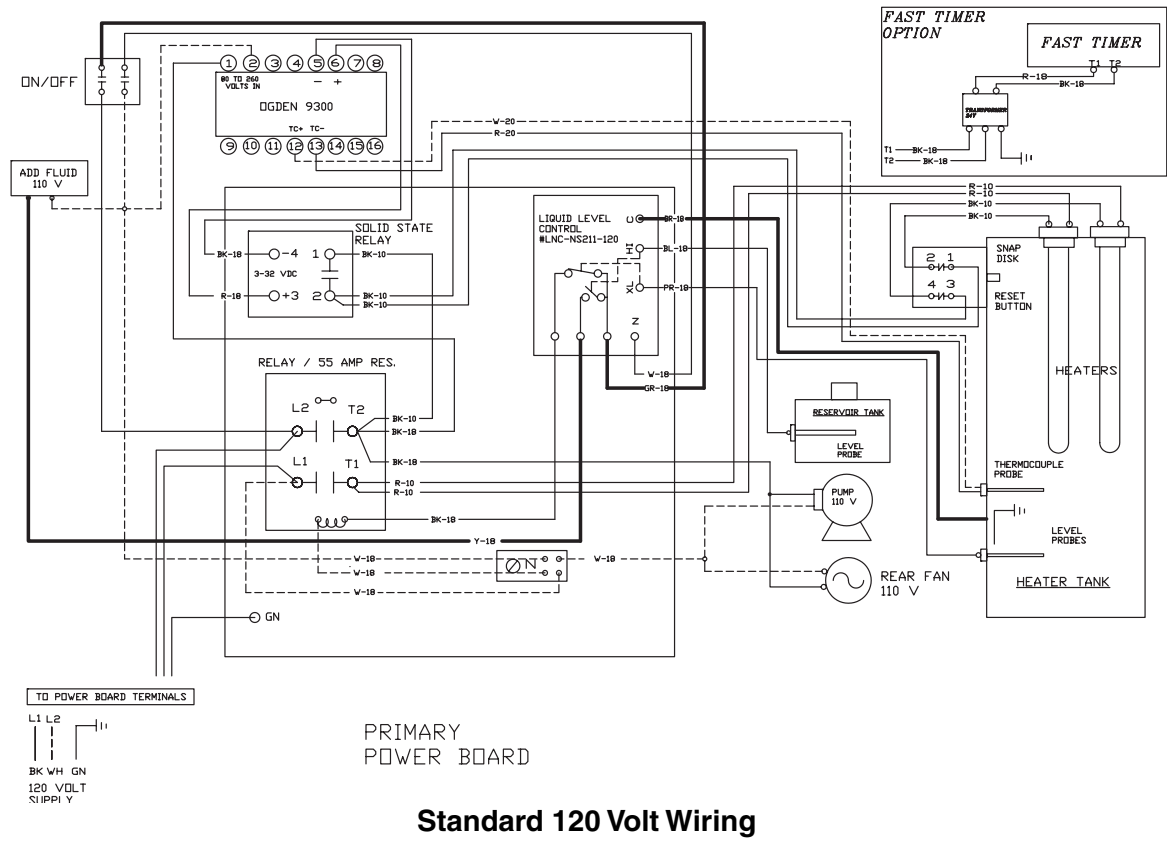
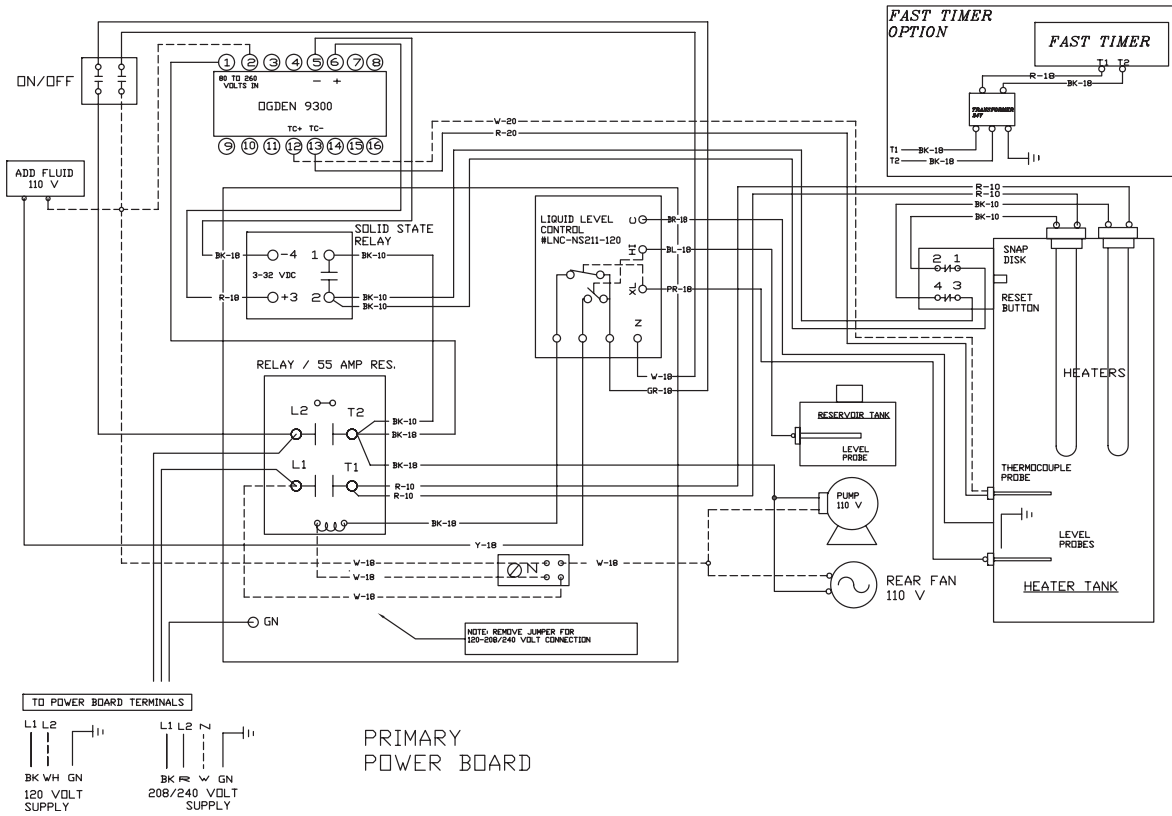

## WARRANTY

Thermodyne Foodservice Products, Inc. warrants to the original purchaser for use of each new Thermodyne Conductive Cooking/Holding Oven the following: Any part which proves to be defective in materials or workmanship within the warranty period will, subject to the terms of this warranty, be repaired or replaced at Thermodyne Foodservice, Inc.'s option. Claims under this warranty must be presented to Thermodyne Foodservice Products, Inc. in writing, promptly.

Thermodyne stainless steel cabinets are warranted for 5 years and all other original equipment parts such as heat transfer plates, doors, casters, fluid system components and electrical components are warranted against defect for two years from the date of purchase.\*

This warranty applies only to Thermodyne Conductive Cooking/Holding Ovens in the Continental United States. This warranty shall not apply if the oven or any part is subjected to accident, casualty, alteration, misuse, abuse, neglect, faulty installation, or if the date of manufacture is altered or removed.

The obligation of Thermodyne Foodservice Products, Inc. is limited specifically to the aforementioned. No additional guarantees or warranty, expressed or implied, to include without limitation warranties of Fitness or Merchantability with respect to Thermodyne Conduction Ovens and Thermodyne Foodservice Products, Inc. regarding other liability with respect thereto including, without limitation, liability for incidental, special, or consequential damages.

### RESPONSIBILITIES OF PURCHASER

It is the responsibility of the purchaser to:

1. Arrange on site electrical services in accordance with Thermodyne specifications.
2. Receive shipment of Thermodyne conduction oven to include unloading, uncrating, inspecting for damage in shipment, and installation of the oven in its proper location; in accordance with installation instructions.
3. Arrange that the electric services are connected properly by a qualified technician. All such connections must be in accordance with applicable code requirements and Thermodyne installation procedures.

Please note the specific details on the Warranty and make certain that service connections are made to the proper utility services. This warranty and purchasers responsibility information should be retained for future reference.

\*For units shipped after 01/01/13 only.

For assistance please call:

Toll Free: (800) 526-9182

Local: (260) 428-2535

## HEAT TRANSFER FLUID MSDS

Dow Chemical U.S.A.  
Midland, MI 48674  
Emergency Phone: 517-636-4400  
Product Code: 23545  
Product Name: PROPYLENE GLYCOL  
HEAT TRANSFER FLUID  
Effective Date: 03-02-88  
Date Printed: 06/02/88  
MSDS: 000130

1. **INGREDIENTS:**  
Propylene glycol CAS# 000057-55-6 95%  
Dipotassium phosphate CAS# 007758-11-4 <5%  
Deionized water CAS#007732-18-5 <5%

This document is prepared pursuant to the OSHA Hazard Communication Standard (29CFR 1910.1200). In addition, other substances not 'Hazardous' per this OSHA Standard may be listed. Where proprietary ingredient shows, the identity may be made available as provided in this standard.

2. **PHYSICAL DATA:**  
BOILING POINT: 370F, 188C  
VAP. PRESS: 0.22 mmHg @ 20C, 68F  
VAP. DENSITY: 2.62  
SOL. IN WATER; Complete  
SP. Gravity: 1.050 @ 60/60F, 16C  
APPEARANCE: Colorless.  
ODOR: Odorless liquid.

3. **FIRE AND EXPLOSION HAZARD DATA:**  
FLASH POINT: 215F, 102C  
METHOD USED: COC  
FLAMMABLE LIMITS  
LFL: 2.6% @ 100C  
UFL: 12.5% @ 130C  
EXTINGUISHING MEDIA: Water fog, alcohol foam, dry chemical  
FIRE AND EXPLOSION HAZARDS: None.  
FIRE-FIGHTING EQUIPMENT: None.

4. **REACTIVITY DATA:**  
STABILITY: (CONDITIONS TO AVOID)  
Stable over normal  
Operating temperature range of -30F to 250F.  
INCOMPATIBILITY: (SPECIFIC MATERIALS TO AVOID)

Oxidizing material.

- HAZARDOUS DECOMPOSITION PRODUCTS: None  
HAZARDOUS POLYMERIZATION: Will not occur,

5. **ENVIRONMENTAL AND DISPOSAL INFORMATION:**  
ACTION TO TAKE FOR SPILLS/LEAKS: Cover with absorbent material, soak up and sweep into bag.

6. **HEALTH HAZARD DATA:**  
EYE: May cause slight transient eye irritation. Corneal injury is unlikely.  
SKIN CONTACT: Essentially nonirritating to skin on prolonged contact.  
SKIN ABSORPTION: A single prolonged skin exposure is not likely to result in absorption of harmful amounts. The LD50 for skin absorption in rabbits is

>10,000 mg/kg.

Repeated exposures may cause slight flaking, tenderness and softening of skin.  
INGESTION: Single does oral toxicity is low. The LD50 for female rats is about 20.3 g/kg

INHALATION: A single prolonged (hours) inhalation exposure is not likely to cause adverse side effects. Mists are not to be hazardous.

**SYSTEMIC & OTHER EFFECTS:**  
Repeated excessive ingestion may cause central nervous system effects. No carcinogenic effects have been seen in long-term animal studies. Birth defects are unlikely. Exposures having no adverse effects on the mother should have no effect on the fetus. In animal studies, has been shown not to interfere with reproduction. Results of mutagenicity tests in vitro (test tube) and in animals have been negative.

7. **FIRST AID**  
EYES: Irrigate immediately with water for at least 5 minutes.  
SKIN: wash off in flowing water or shower  
INGESTION: Induce vomiting if large amounts are ingested, consult medical  
INHALATION: Remove to fresh air if effects occur. Consult medical.  
NOTE TO PHYSICIAN: No specific antidote. Supportive care. Treatment based on judgment of the physician in response to reactions of the patient.

8. **HANDLING PRECAUTIONS:**  
EXPOSURE GUIDELINE (S): Dow IHG is 10mg/m3 for propylene glycol mist. Dow IHG 440 ppm for propylene glycol vapors.  
VENTILATION; Good general ventilation sufficient.  
RESPIRATORY PROTECTION: No respiratory protection should be needed.  
SKIN PROTECTION: No precautions other than clean body covering should be needed.  
EYE PROTECTION: Use safety glasses.

9. **ADDITIONAL INFORMATION:**  
REGULATORY REQUIREMENTS:  
SARAHAZARD CATEGORY: This product has been reviewed according to the EPA 'Hazard Categories' promulgated under Section 311 and 312 of the Superfund Amendment and Reauthorization Act of 1986 (SARA Title III) and is considered, under applicable definitions, to meet the following categories: A delayed hazard.  
SPECIAL PRECAUTIONS TO BE TAKEN IN HANDLING AND STORAGE: Exercise reasonable care and caution.  
MSDS STATUS: Revised Section 9