



# Literature Assembly

## 911-0803

Contains the following:

2100-591	Users Information Manual
2100-721(D)	W**G4 Gas/Electric Manual
2100-367(B)	Trouble Shooting Manual WG
2100-479	Leak Test, Evacuation, Charging
2110-821(F)	Replacement Parts Manual
7960-805(A)	S8201-169 CCM Instructions
4085-177(E)	Wiring Diagram
4085-277(E)	Wiring Diagram
4085-400(E)	Wiring Diagram
7960-420	Warranty





Bard Manufacturing Company, Inc.  
Bryan, Ohio 43506  
*Since 1914...Moving ahead, just as planned.*

Manual: 2100-591  
Supersedes: **NEW**  
File: Vol I, Tab 20  
Date: 04-10-13

## USER'S INFORMATION MANUAL

### WG-Series Combination Gas/Electric Wall-Mount™

We're pleased you've chosen our air conditioner/gas furnace to supply your cooling/heating needs. Please keep this manual in a safe, yet readily available place. It contains important and useful information.

**ATTENTION, INSTALLER:** After installing air conditioner/gas furnace, give the user:

- User's Information Manual
- Parts List
- Installation Instructions
- Warranty Information

**ATTENTION, USER!** Your installer should give you the above four important documents relating to your air conditioner/gas furnace. Keep these as long as you do your equipment. Pass these documents on to later purchasers or furnace users. If any of the four documents are missing or damaged, contact your installer or manufacturer for replacement. For efficient service, please give your unit model and serial number, from Section 1 or from your serial rating plate.



## WARNING

If the information in this manual is not followed exactly, a fire or explosion may result causing property damage, personal injury or loss of life.

- Do not store or use gasoline or other flammable vapors and liquids in the vicinity of this or any other appliance.
- **WHAT TO DO IF YOU SMELL GAS**
  - Do not try to light any appliance.
  - Do not touch any electrical switch; do not use any phone in your building.
  - Immediately call your gas supplier from a neighbor's phone. Follow the gas supplier's instructions.
  - If you cannot reach your gas supplier, call the fire department.
  - Installation and service must be performed by a qualified installer or the gas supplier.



## WARNING

Read and follow all safety information in this manual, operating instructions and furnace safety labels. Failure to follow safety precautions could result in damage, injury or death.

**IMPORTANT SAFETY NOTE:** You must know how to turn off gas and electricity to air conditioner/gas furnace. Your qualified installer, service agency or gas supplier can teach you to use controls and switches.



## WARNING

Do not use this air conditioner/gas furnace if any part has been under water. Immediately call a qualified service technician to inspect the unit and to replace any part of the control system and any gas control which has been underwater.

*Thank you for reading these safety statements. Please read on so you will know how to maintain your air conditioner/gas furnace for years of dependable service.*

# CONTENTS

---

<b>Section 1</b>		<b>Figures</b>	
Rating Plate Information .....	3	Figure 1	Typical Gas Piping ..... 8
<b>Section 2</b>		Figure 2	Step-by-Step Instructions on Lighting Burners..... 11
Important Safety Precautions .....	3 & 4	Figure 3	Filter Locations ..... 13
<b>Section 3</b>		Figure 4	Periodic Inspections ..... 13
Understanding How Your Furnace and Air Conditioner Works .....	5 & 6	Figure 5	Location of Access Panels
<b>Section 4</b>			
Turning Off Furnace in an Emergency .....	6, 7 & 9		
<b>Section 5</b>			
Operating Your Furnace.....	10		
<b>Section 6</b>			
Proper Maintenance of Your Furnace and Air Conditioner .....	10, 12 & 14		
<b>Section 7</b>			
Ventilation Options.....	15		
<b>Section 8</b>			
Replacement Parts .....	15		
<b>Section 9</b>			
Outdoor Coil .....	15		

BARD MANUFACTURING COMPANY, INC.  
BRYAN, OHIO USA 43506

## SECTION 1 • RATING PLATE INFORMATION

Record the manufacturer's name, unit model number and serial number below. These are your furnace rating plate. Record installation date which is important for warranty purposes.

### YOUR FURNACE INFORMATION

Furnace Type \_\_\_\_\_

Manufacturer's Name \_\_\_\_\_

Model Number \_\_\_\_\_

Serial Number \_\_\_\_\_

Date Installed \_\_\_\_\_

Installer/Service \_\_\_\_\_

Address \_\_\_\_\_

City/State/Zip Code \_\_\_\_\_

Telephone Number \_\_\_\_\_

## SECTION 2 • IMPORTANT SAFETY PRECAUTIONS

### 2.A HAZARD ALERT SYMBOL



An exclamation point surrounded by a triangle.

### 2.B SIGNAL WORDS

Years of safe, dependable service are assured when you understand and follow all safety precautions.

Signal words “**WARNING**” and “**CAUTION**” alert you to potential hazards.

“**WARNING**” indicates a potentially hazardous situation which, if not avoided, could result in death or serious injury.

“**CAUTION**” indicates a potentially hazardous situation which, if not avoided, may result in minor or moderate injury. It may also be used to alert against unsafe practices. It can also be used to signal property damage only potential.

### 2.C. SAFETY PRECAUTIONS

These are some of our most important safety precautions; others are throughout this manual. Please read and follow them.

***THIS PRODUCT MUST BE GAS PIPED BY A LICENSED PLUMBER OR GAS FITTER IN THE COMMONWEALTH OF MASSACHUSETTS.***

### 2.1 GAS AND COMBUSTION PRODUCTS



Any condition that will allow gas or combustion products to enter furnace area can cause nausea, asphyxiation or fire resulting in damage, injury or death.

Natural gas and propane (LP) gas have characteristic odors. When your furnace is operating correctly, you should not smell any unfamiliar odor. Normally, burning gas with air produces combustion products which contain carbon dioxide, oxygen and water vapor. Under abnormal conditions, combustion products can contain aldehydes and carbon monoxide.

- Aldehydes have a strong pungent, acrid smell that can cause nausea.
- Carbon monoxide is tasteless, colorless and odorless. It can cause headaches, flu-like symptoms or nausea. We refer to all these symptoms as nausea in this manual. It can also cause death by asphyxiation.

## **WARNING**

Any unfamiliar smell can alert you to presence of gas or aldehydes. If you detect any unfamiliar odor follow instruction in Section 4.B.1. Otherwise, nausea, asphyxiation or fire could occur resulting in damage, injury or death.

## **WARNING**

Do not block or cover combustion openings in the furnace. Blocking or covering these openings could cause nausea, asphyxiation or fire resulting in damage, injury or death.

## **WARNING**

A loud noise may mean faulty burner ignition. If your furnace makes a loud noise, turn it off. Follow instructions in Section 4.B.2. If you don't turn off your furnace, it could cause fire or an explosion resulting in damage, injury or death.

## **WARNING**

Do not operate furnace with blower door open or removed. Do not alter furnace to allow operation with blower door removed. Doing either could allow combustion products to circulate throughout the furnace area causing nausea, asphyxiation or fire resulting in damage, injury or death.

## **WARNING**

Front door must be in place during furnace operation. Hot surfaces behind front door.

### 2.2 STORAGE AND USE OF FLAMMABLE, CORROSIVE AND COMBUSTIBLE PRODUCTS NEAR YOUR FURNACE

## **WARNING**

Never store or use flammable liquids or vapors near or on your furnace. These include gasoline, kerosene, cigarette lighter fluid, cleaning fluids, solvents, paint thinners or painting compounds. Flammable vapors can travel great distances before igniting.

## **WARNING**

Never store or use anything near or on your furnace that can produce vapors that are corrosive to gas-fired furnaces. Vapors from products containing chlorines, fluorines, bromines and iodines can cause vent system or heat exchanger failure. Examples of such products are spray or aerosol containers, detergents, bleaches, cat litter, waxes, adhesives, solvents and other cleaning compounds. Vent system or heat exchanger failure could cause nausea, asphyxiation or fire resulting in damage, injury or death.

## **WARNING**

Never store anything combustible near or on your unit. A fire could occur resulting in damage, injury or death.

## 2.3 ALTERATION OF FURNACE CONTROLS



# WARNING

Do not alter any gas or electrical controls (gas control or safety controls) in any manner. Altering them could cause furnace to operate unsafely resulting in damage, injury or death.

## SECTION 3 • UNDERSTANDING HOW YOUR FURNACE WORKS

Your installer should have given you a detailed explanation of how the furnace operates. Shown below are the basic operation characteristics and sequence of operation. If you have any questions consult your installer and/or service agency.

### \* \* IMPORTANT \* \*

There are many types of thermostats compatible with this furnace. Make sure you understand the specific type installed. Ask installer for detailed explanation, and retain thermostat instruction manual for reference.

This furnace is equipped with a vent shut-off system which monitors the combustion air into the burners by means of a pressure sensing device. When the vent becomes blocked, this device turns off the gas valve circuit to prevent flue products from entering the structure. In the event that this occurs, shut off furnace and contact a qualified service agency.

### 3.1 BASIC OPERATION – HEATING CYCLE

This furnace is operated by an Integrated Furnace Control (IFC) and a gas control system which controls all functions of the furnace.

On a call for heat from the thermostat, the IFC first turns on the inducer motor. The pressure switch then closes signaling the ignition control to proceed with ignition function.

The ignition system consists of a direct spark igniter (DSI) and remote sensor. When the thermostat calls for heat the DSI sparks to light main burner gas. Once ignited the remote sensor confirms flame carry over to all burners.

There is a 60-second delay after main burner is on until the comfort air blower starts on heating speed. After the thermostat is satisfied, the burners will go off as gas valve closes. The inducer will continue to run for 30 seconds, and the comfort air blower will continue to run for 2-1/2 minutes.

### 3.2 BASIC OPERATION – COOLING CYCLE

On a call for cool the compressor and condenser fan will start immediately, and the comfort air blower will start 7 seconds later on cooling speed. Note: Some models may be equipped with optional Low Ambient Control that will cycle the condenser fan motor to maintain proper refrigerant pressures under lower outdoor temperature conditions. When the thermostat is satisfied the compressor and condenser fan will stop and the comfort air blower will continue to operate for 60 seconds.

#### 3.2.1 COMPRESSOR CONTROL MODULE (CCM)

All models are equipped with a compressor control module. This control is an anti-short cycle/lockout timer with high and low pressure switch monitoring and alarm relay output.

#### Delay on Make Timer and Break Time Delay

- On initial power up, or any time the power is interrupted to the unit, the delay on make period begins. This delay will be 2 minutes plus 10% of the delay on break setting. This feature assures that pressures will be equalized for normal start up if there are brief power interruptions, and can accommodate staggered starts for dual unit installations as long as the off delay periods are set differently for the two units.
- During routine operation of the unit with no power interruptions the compressor will operate on demand with no delay as long as off delay time has been met.
- Adjustable 30-second to 5-minute delay on break timer assures that pressures can equalize if units are short cycled by the operating controls or personnel. Recommended settings would be 2 minutes for unit 1 and 3 minutes for Unit 2.

## High Pressure Switch and Lockout Sequence

- If the high pressure switch opens, the compressor contactor will de-energize immediately. The lockout time in the CCM will go into a soft lockout and stay locked out until the high pressure switch closes and the delay on break has expired.
- If the high pressure switch opens again during the same operating cycle the CCM will go into a manual lockout condition.
- Recycling the wall thermostat resets the manual lockout.

## Low Pressure Switch, Bypass and Lockout Sequence (Optional)

- If the low pressure switch opens for more than 120 seconds the compressor contactor will de-energize and the CCM will go into soft lockout.
- Regardless of the state of the low pressure switch the compressor contactor will reenergize after the delay on break time has expired.
- If the low pressure switch remains open, or opens again for longer than 120 seconds, the CCM will go into a manual lockout and the alarm relay circuit will energize.
- Recycling the wall thermostat resets the manual lockout.

*NOTE: Both high and low pressure switch controls are inherently automatic reset devices. The high pressure switch opens at 425 and closes at 325 psig, and the low pressure switch opens at 14 and closes at 30 psig. The lockout features, both soft and manual, are a function of the Compressor Control Module.*

## Alarm Relay Output

- Alarm terminal on Compressor Control Module is 24V AC output connection for applications where signal is desired. This terminal is powered whenever compressor is in manual lockout due to high pressure or low pressure sequences as described.

## PHASE MONITOR

All units with three phase scroll compressors are equipped with a three phase line monitor to prevent compressor damage due to phase reversal.

The phase monitor in this unit is equipped with two LEDs. If the “&” signal is present at the phase monitor and phases are correct, the green LED will light.

If phases are reversed, the red fault LED will be lit and compressor operation is inhibited.

## 3.3 MANUAL FAN (CONTINUOUS AIRFLOW) OPERATION

If wall thermostat is set to MANUAL (ON) position to operate comfort air blower continuously to provide air circulation throughout the building, the blower will operate on the heating speed rather than the cooling as is typical with most systems. This permits the air to circulate as desired but helps keep the operating noise level down as well as conserving energy.

During a call for cooling, the blower automatically shifts up to cooling speed, and remains there until 60 seconds after thermostat is satisfied then drops back to heating speed.

## SECTION 4 • TURNING OFF FURNACE IN AN EMERGENCY

### **WARNING**

Have a qualified installer, service agency or gas supplier teach you location and operation of gas and electrical shut-off devices. Ask them any questions you have about this section. If you don't turn off your furnace in an emergency damage, injury or death could result.



In an emergency you *must* know how to turn off gas and electricity. Find out how *before* the emergency.

 <b>WARNING</b>
Should overheating occur or the gas supply fail to shut off, shut off the manual gas valve to the furnace before shutting off the electrical supply. Failure to do so can cause a fire or explosion which could result in damage, injury or death.

#### 4.A GAS AND ELECTRICAL SHUT-OFF DEVICES

##### 1. GAS SHUT-OFF DEVICES

In an emergency, you may not be able to reach all the gas shut-off devices. You must know how to turn off gas using any one of the three manual types:

- a. Manual Shut-off Switch on Gas Control  
Gas control location is behind the access panel on the right side. See Lighting and Shutdown Instructions in Section 5 for more information.

To turn gas control furnace knob OFF, turn it to “OFF” position. Use this same procedure when you leave a vacation home vacant and do not want the furnace to operate.

- b. Manual In-Line Shut-off Valve in Gas Supply Line.

This valve could be next to furnace. Figure 1 shows a typical installation.

Normally, gas is ON when you turn the shut-off valve handle parallel to gas pipe. Gas is OFF when you turn handle 90° from gas pipe.

- c. Manual Shut-off Valve at Natural Gas Meter or Propane (LP) Gas Tank.

Normally, natural gas is ON when you turn shut-off parallel to gas pipe. Gas is OFF when you turn shut-off 90° from gas pipe. Some valves require a wrench or other tools.

##### 2. ELECTRICAL SHUT-OFF DEVICES

In an emergency, you may not be able to reach both of your electrical shut-off devices.

Therefore, you must know how to turn off electricity using either one of them. Here are two types of electrical shut-off devices:

- a. There should be an electrical shut-off device located on or immediately adjacent to the furnace.
- b. There should be a separate circuit breaker or fuse serving only the furnace located in the main circuit breaker or fuse panel. Know its location and make sure this device is clearly identified.

**FIGURE 1  
TYPICAL GAS PIPING**

UNIT	"A" LENGTH
WG24-36	8"
WG42-60	10"

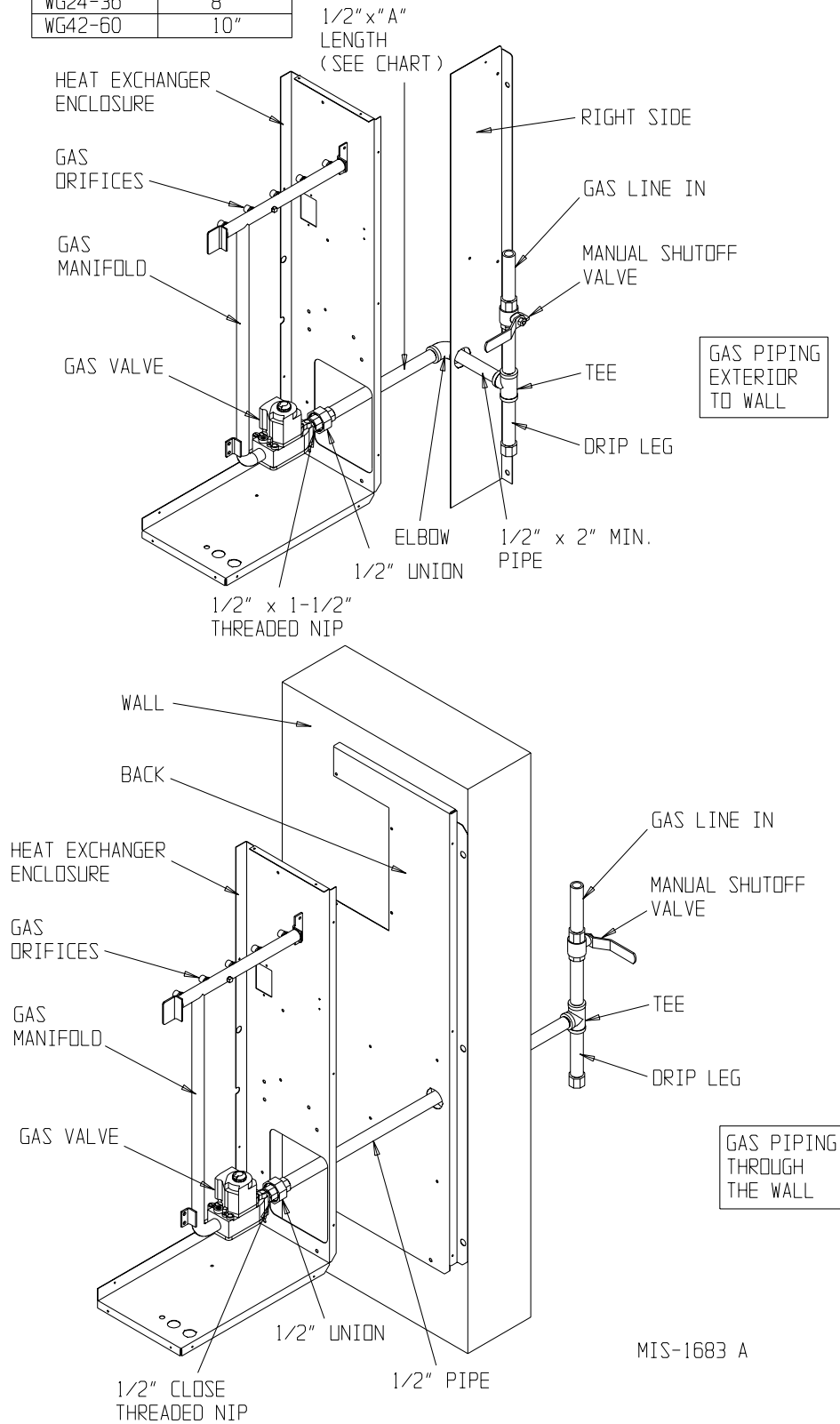

MIS-1683 A

#### 4.B POSSIBLE EMERGENCIES AND RECOMMENDED ACTIONS



## WARNING

If gas or electricity is off due to an emergency, only a qualified installer, service agency or gas supplier should turn it back on. Doing it yourself could result in damage, injury or death.

1. **Possible Emergency:** Smelling gas or other unfamiliar smell; or not knowing what may be wrong or what to do about it.

**ACTION:** For your safety –

- a. Leave your house or building immediately.
- b. Go to a neighbor's or another building.
- c. Use their telephone.
- d. Call your gas supplier. Tell them you smell gas and give them your name and address.
- e. If you cannot reach gas supplier, call fire department.



## WARNING

Three important **things not to do** –

1. Don't try to light any gas appliances.
2. Don't touch any electrical switches
3. Don't use the telephone in your house or building.

Any of the above may cause a spark which could cause a fire or explosion resulting in damage, personal injury or death.

2. **Possible Emergency:** Your thermostat is set below room temperature; yet even though the blower is on, the air coming from your room registers continually gets hotter.

**ACTION:**

- a. Turn room thermostat to its lowest or OFF setting.
- b. If you can do so safely, turn gas off. Use manual shut-off valve at gas meter or on propane (LP) gas tank. You may need a wrench or tools. If you can safely turn off electricity at the main circuit panel, do so. If you cannot do these things safely, leave your home or building immediately. Call your gas supplier or fire department from a neighbor's phone for help.

3. **Possible Emergency:** Your thermostat is set above room temperature. The blower is on but the air coming from your room registers is hot, then cold, then hot, then cold in a continuing cycle. This condition indicates lack of airflow through furnace.

**ACTION:**

- a. Make sure air filter is clean and installed correctly.
- b. Check that registers and return air grilles are open and unobstructed.
- c. If condition continues, call your local qualified service technician or gas supplier.

4. **Possible Emergency:** While furnace is operating, you smell unfamiliar odors that go away when furnace is off.



## WARNING

Unfamiliar odors may mean gas or aldehydes are present which could result in damage, injury or death.

**ACTION:**

- a. Turn thermostat to its lowest or OFF setting.
- b. Move gas valve control knob to OFF position.
- c. If blower is not operating, immediately turn off electricity to furnace using shut-off device near furnace or at main circuit panel.
- d. If blower is operating, wait five minutes for furnace to cool down and then turn off electricity to furnace using shut-off device near furnace or at main circuit panel.
- e. Call your local qualified service technician or gas supplier.

5. **Possible Emergency:** Main electrical circuit breaker for furnace cannot be reset without tripping again or new fuses continue to blow.

**ACTION:**

- a. Move gas valve control knob to OFF.
- b. Call your local qualified service technician or gas supplier.

**SECTION 5 • OPERATING YOUR FURNACE**

After reading the Safety Information and Precautions follow Operating Instructions on front door of furnace and instructions repeated on Page 11.

 <b>WARNING</b>
If you do not follow these instructions exactly a fire or explosion could occur resulting in damage, injury or death.

 <b>WARNING</b>
Never use tools to move gas control knob. Only use your hand. If gas control knob will not move by hand, do not force it or try to repair it. Call a qualified installer, service agency or gas supplier. Forcing knob can cause gas to leak which could result in fire or explosion resulting in damage, injury or death.

Properly operating your furnace requires certain abilities, mechanical skills and tools. If you are uncertain about your abilities or if you lack proper skills or tools, do not proceed. Instead, contact a qualified installer, service agency or gas supplier.

An automatic ignition device lights the burners. Do not try to light manually. See Figure 2 on Page 11 for step by step instructions.

**SECTION 6 • PROPER MAINTENANCE OF YOUR FURNACE**

You need special abilities, mechanical skills and tools to maintain your furnace properly. If you are uncertain about your abilities or if you lack proper skills or tools, do not try to maintain or repair your furnace yourself. Instead, contact a qualified installer, service agency or gas supplier.

**6.A IF YOU SMELL GAS OR ANY UNFAMILIAR SMELL WHILE WORKING ON YOUR FURNACE:**

- 1. Do not try to light main burners.
- 2. Do not touch or turn on any electrical switch.
- 3. Do not use any phone in your building.
- 4. Immediately call your gas supplier from a neighbor's phone. Follow gas supplier's instructions.
- 5. If you cannot reach your gas supplier, call fire department.

**6.B LUBRICATION REQUIREMENTS**

The main blower motor, outdoor fan motor, and the induced draft blower motor are permanently lubricated, and no maintenance is required.

**6.C MAKE SURE AIR FILTER(S) IS IN PLACE**

Ask your installer, local qualified service technician or gas supplier to make sure your filter(s) is in place properly. Become familiar with its location and procedures for removing, cleaning and replacing it.

Recommended filter sizes are shown below.

Main System Filter: 20x30x2 throwaway for WG42-60 models, and 20x25x2 throwaway for WG24-36 models.

See Figure 3 on Page 13 for filter locations.

 <b>WARNING</b>
Operating furnace without clean air filter(s) can damage blower motor, heat exchanger or air conditioning system components. This can cause system failure which could result in damage or injury.

FIGURE 2  
START UP PROCEDURE

## FOR YOUR SAFETY READ BEFORE OPERATING

**WARNING:** If you do not follow these instructions exactly, a fire or explosion may result causing property damage, personal injury or loss of life.

- A. This appliance does not have a pilot. It is equipped with an ignition device which automatically lights the burner. Do NOT try to light the burner by hand.
- B. BEFORE OPERATING smell all around the appliance area for gas. Be sure to smell next to the floor because some gas is heavier than air and will settle on the floor.

### WHAT TO DO IF YOU SMELL GAS

- \*Do not try to light any appliance.
- \*Do not touch any electric switch; do not use any phone in your building.
- \*Immediately call your supplier from a neighbor's phone. Follow the gas supplier's instructions.

\*If you cannot reach your gas supplier; call the fire department.

- C. Use only your hand to push in or move the gas control lever. Never use tools. If the lever will not push in or turn by hand, don't try to repair it, call a qualified service technician. Force or attempted repair may result in a fire or explosion.
- D. Do not use this appliance if any part has been under water. Immediately call a qualified service technician to inspect the appliance and to replace any part of the control system and any gas control which has been under water.

## OPERATING INSTRUCTIONS

1. STOP! Read the safety information above on this label.
2. Set the thermostat to lowest setting.
3. Turn off all electric power to the appliance.
4. This appliance is equipped with an ignition device which automatically lights the burner. Do NOT try to light the burner by hand.

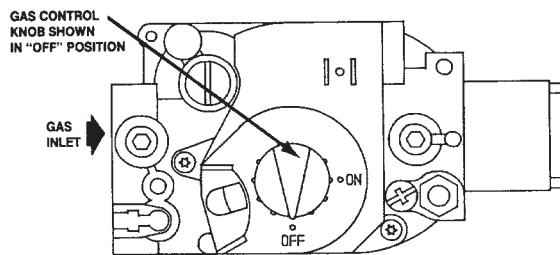

5. Remove control access panel.
6. Push in gas control knob slightly and turn clockwise to "OFF".  
NOTE: Knob cannot be turned to "OFF" unless knob is pushed in slightly. Do not force.
7. Wait five (5) minutes to clear out any gas. Then smell for gas, including near the floor. If you smell gas, STOP! Follow "B" in the safety information above on this label. If you don't smell gas, go to the next step.
8. Turn gas control knob counterclockwise to "ON".
9. Replace control access panel.
10. Turn on all electric power to the appliance.
11. Set thermostat to desired setting.
12. If the appliance will not operate, follow the instructions "To Turn Off Gas To Appliance" and call your service technician or gas supplier.

## TO TURN OFF GAS TO APPLIANCE

1. Set the thermostat to lowest setting.
2. Turn off all electric power to the appliance if service is to be performed.
3. Remove control access panel.
4. Push in gas control lever slightly and move to "OFF". Do not force.
5. Replace control access panel.

7961-509

## 6.D KEEP AIR FILTER(S) CLEAN

As a user, your personal responsibility is to keep air filter(s) clean.



### CAUTION

A dirty air filter(s) reduces system efficiency and can cause erratic control performance. These could result in damage to blower motor or heat exchanger.

1. During the first four weeks after your furnace is installed, inspect your air filter(s) for dirt every week. Then check the filters monthly and replace as necessary.
2. If the filter(s) is of a washable type, clean filter(s) according to the manufacturer's specifications.



### WARNING

After cleaning or changing filter(s), filter access must be closed and latched. Failure to do so could cause nausea, asphyxiation, or fire resulting in damage, injury or death.

## 6.E DO NOT OBSTRUCT DUCT WORK

For proper operation, keep registers and return air grilles open. Do not cover or block them with rugs, carpets, drapes or furniture.

## 6.F HAVE YOUR FURNACE CHECKED ANNUALLY

The furnace, vent terminal, and the combustion air intake hood should be inspected yearly by a qualified service agency, generally prior to the heating season. Detailed procedures for this inspection are contained in the instructions booklet and should be handled by the qualified service agency only.

A general inspection of the furnace, the furnace area and the vent terminal should be conducted on a regular basis by the owner/occupant. This review should include:

1. Make sure the furnace always has the minimum clearance as detailed on the furnace rating plate. Special attention must be given to these items if any remodeling is done.

2. Make sure the vent terminal is in place and is physically sound.
3. Reviewing that the return air duct connection(s) is physically sound, is sealed to the furnace casing.
4. The physical support of the furnace is sound without sagging, cracks, gaps, etc. around the unit so as to provide a seal between the unit and the structure.
5. Inspect for any obvious signs of deterioration of the furnace.
6. Periodic examinations of the vent terminal should also be conducted by the owner on a regular basis, preferably every month but at least every two months during the heating season.
7. Check the entire vent terminal for any blockage. If any debris is present remove it.
8. If unit is vertically vented, inspect vent system annually including drain tube. Clean or replace if necessary.

## 6.G THE FOLLOWING PROCEDURE SHOULD BE FOLLOWED FOR THE PERIODIC INSPECTION AS CONDUCTED BY THE OWNER/OCCUPANT.

1. Set the wall thermostat to the OFF position or lower the set point lever to a temperature well below the existing room temperature. Shut off electric power to the furnace. A circuit breaker is located behind the lower, small access panel on the right side.
2. Remove the burner access door. See Figure 4.
3. Use flashlight or trouble light to observe the burner compartment and burners. There should be very minimal scaling or sooting in this area. Any loose debris may be vacuumed out. Also observe the sides of the heat exchanger tubes for "hot spots" due to improper burner alignment or overfiring and give particular attention to any area where it looks like there may be any deterioration from corrosion or rusting. Observe for any corrosion on the burners themselves. Should anything appear questionable, contact your service agency.

**FIGURE 3  
FILTER LOCATIONS**

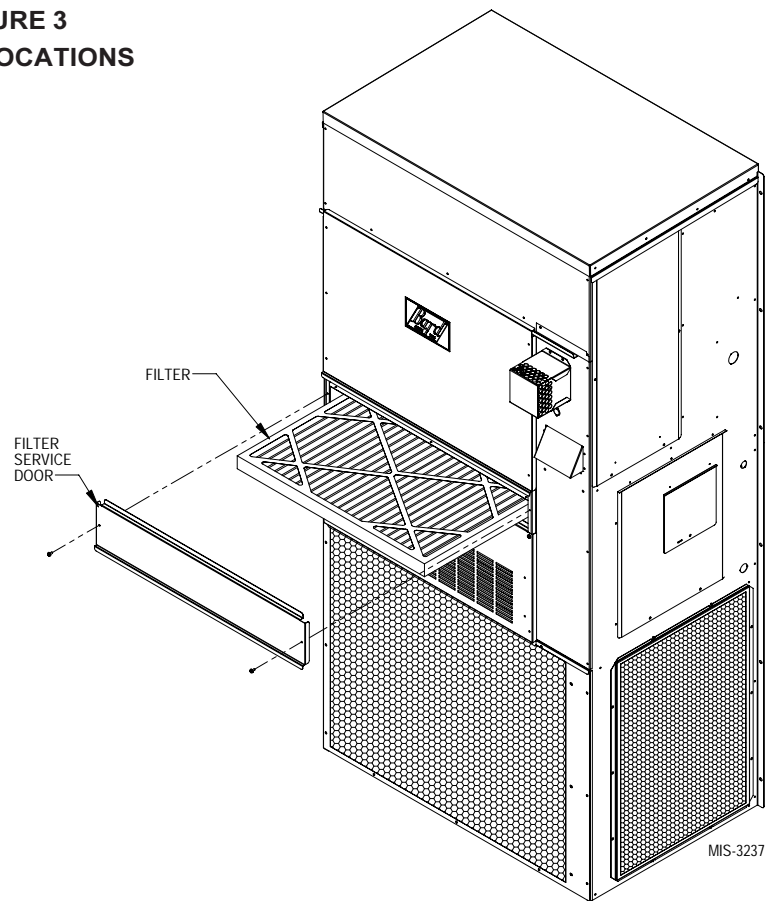

**FIGURE 4  
PERIODIC INSPECTIONS**

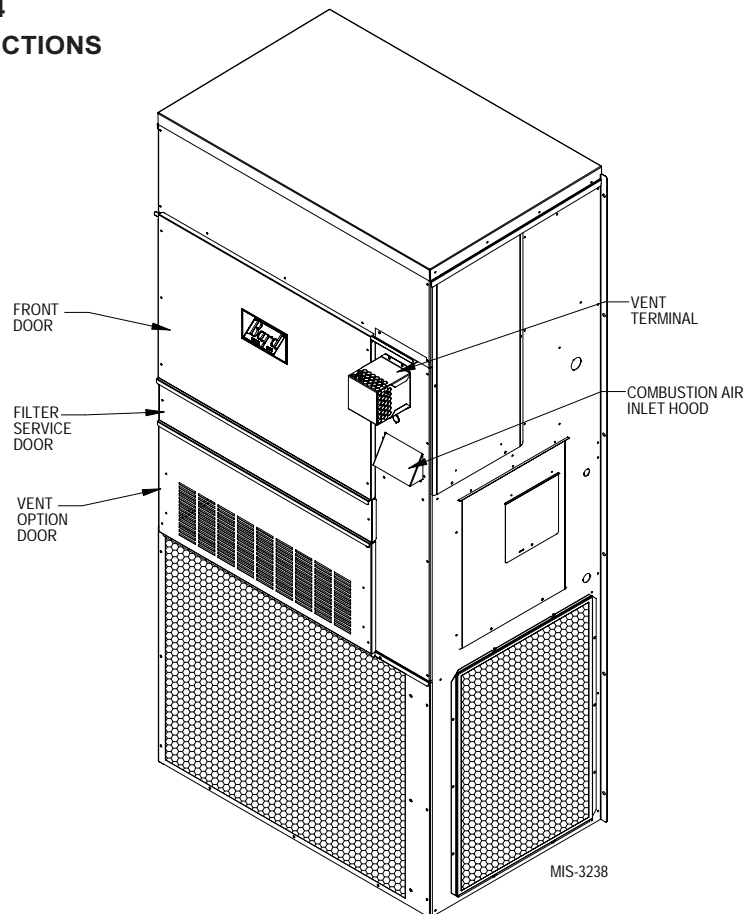



4. Inspect the vent terminal, or vent system observing for any debris from weather, birds, and the like. Clean if necessary. Also check the combustion air inlet hood to make sure it is clear. See Figure 4.



## WARNING

Leakage of products of combustion into the living area may result in asphyxiation resulting in injury or death

5. Restore the electrical power to the furnace by turning the switch back on. Adjust the thermostat to call for heating operation.
6. Observe the main burners flames. The main burners should be mostly “blue” with possibly a little orange (not yellow) at the tips of the flames. The flames should be in the center of the heat exchanger compartments and not impinging on the heat exchanger surfaces.
7. Observe the flames until the blower starts (there is a normal delay 30 second period until the heat exchanger warms up). There should be no change in the size or shape of the flame. If there is any wavering or blowing of the flame on the blower start-up, it is an indication of a possible leak in the heat exchanger. Turn off the gas valve in the gas line leading to the furnace, and then the main electrical switch to the furnace and call your service agency.
8. Replace the burner access door.



## **SECTION 7 • VENTILATION OPTION ASSEMBLIES**

The standard Barometric Fresh Air Damper (BFAD) allows up to 25% outside fresh air to be introduced to the building whenever the main unit comfort air blower is operating.

The optional Blank Off Plate (BOP) is installed on the inside of the vent option door to cover the air inlet openings which eliminates outside air from entering the unit.

The optional Motorized Fresh Air Damper (MFAD) allows up to 25% outside fresh air to be introduced to the building through a two position damper which can be fully open or closed.

The optional Commercial Room Ventilator (CRV) allows up to 50% outside fresh air to be introduced to the building and includes a built-in exhaust damper. The CRV complies with ASHRAE Standard 62.1 “Ventilation for Acceptable Indoor Air Quality”.

## **SECTION 8 • REPLACEMENT PARTS**

Replacement parts for the gas/electric units are available through local distributors.

A replacement parts list manual is supplied with each unit. When ordering parts or making inquiries pertaining to any of the units covered by these instructions, it is very important to always supply the complete model number and serial number of the unit. This is necessary to assure that the correct parts (or an approved alternate part) are issued to the service agency.

## **SECTION 9 • OUTDOOR COIL**

Periodic cleaning of the outdoor coil to permit full and unrestricted airflow circulation is essential. Reduced airflow through the outdoor coil can shorten equipment service life as well as increase operating costs.



---

# INSTALLATION INSTRUCTIONS

---

## Wall Mounted Gas/Electric

Models:

W24G4	W30G4	W36G4	W42G4	W48G4	W60G4
W24G4D	W30G4D	W36G4D	W42G4D	W48G4D	W60G4D

---

### **WARNING**

READ ALL INSTRUCTIONS CAREFULLY BEFORE BEGINNING THE INSTALLATION.

THE INSTALLATION MUST COMPLY WITH THESE INSTRUCTIONS AND THE REQUIREMENTS OF ALL GOVERNING CODES AND ORDINANCES FOR THE INSTALLATION LOCATION.

IT IS THE RESPONSIBILITY OF INSTALLER TO KNOW AND UNDERSTAND ALL OF THESE REQUIREMENTS.

FAILURE TO DO SO COULD CREATE A HAZARD RESULTING IN PROPERTY DAMAGE, BODILY INJURY, OR DEATH.



*Climate Control Solutions*

Bard Manufacturing Company, Inc.  
Bryan, Ohio 43506  
[www.bardhvac.com](http://www.bardhvac.com)

Manual No.: 2100-721D  
Supersedes: 2100-721C  
Date: 7-20-21

# CONTENTS

---

	<b>Page</b>		<b>Page</b>
<b>Getting Other Information and Publications ...</b>	<b>4</b>	19. Manifold Pressure Adjustment .....	29
<b>Wall Mount Gas/Electric General Information..</b>	<b>5</b>	20. Checking Gas Input Rate.....	29
W**G Series Model Nomenclature.....	5	21. Standard Orifice Sizing and High Altitude Derate.....	31
Ventilation Options .....	5	22. Conversion of Gas Input BTUH from High to Low Rating.....	34
Air Conditioning Module Options.....	6	23. Measuring Air Temperature Rise.....	34
1. Transportation Damage.....	10	24. Filters .....	34
2. Important .....	10	25. Compressor Control Module .....	35
3. General Information .....	10	26. Phase Monitor .....	37
4. Application .....	10	27. Lighting and Shutdown Instructions .....	37
5. Duct Work.....	10	28. Service Agency Procedures .....	38
6. High Altitude Applications.....	11	29. Maintaining Unit in Good Working Order .....	38
7. Wall Mounting Information .....	11	30. Troubleshooting NIDEC SELECTECH Series ECM Motors.....	39
8. Mounting the Unit .....	11	31. Replacement Parts .....	41
9. Clearances.....	18	32. Sequence of Operation – Heating .....	42
10. Vent Terminal and Combustion Inlet Hood.....	19	33. Sequence of Operation – Cooling.....	42
11. Optional Vertical Venting .....	19	34. Setting Unit Airflow .....	43
12. Vent Resizing Instructions .....	20	35. Pressure Service Ports .....	52
13. Fresh Air Intake.....	20	36. R-410A Refrigerant Charge .....	53
14. Condensate Drain .....	20	37. Fan Blade Setting Dimensions .....	53
15. Wiring – Main Power .....	20	38. Low NOx Burner Assembly "N" Suffix Models Only – U.S. Installations Only .....	53
16. Wiring – Low Voltage Wiring.....	21	INDEX – Wiring Diagrams .....	54
17. Thermostats.....	23		
18. Gas Supply and Piping.....	28		

<b>FIGURES</b>	<b>Page</b>
Figure 1	Unit Dimensions ..... 9
Figure 2A	Mounting Instructions – W24-36G ..... 13
Figure 2B	Mounting Instructions – W42-60G ..... 14
Figure 3A	Combustible Clearance – W24-36G ..... 15
Figure 3B	Combustible Clearance – W42-60G..... 15
Figure 4	Wall Mounting Instructions..... 16
Figure 5	Wall Mounting Instructions..... 16
Figure 6	Common Wall Mounting Installations.... 17
Figure 7	Location of Vent Terminal in Shipping .. 18
Figure 8	Vent Terminal and Combustion Air Inlet Hood ..... 19
Figure 9	Fresh Air Damper ..... 20
Figure 10	Installation of Flexible Conduit ..... 21
Figure 11	Low Voltage Wiring – All Units Except Units with Economizers..... 24
Figure 12	Low Voltage Wiring – Thermostat Using Separate Temperature and Humidity Controllers..... 25
Figure 13	Low Voltage Wiring – JIFM Economizer..... 26
Figure 14	Gas Pipe Connection..... 27
Figure 15	Proper Piping Practice ..... 28
Figure 16	Access Internal Filter through Upper Service Door..... 35
Figure 17	8201-169 Compressor Control Module ... 36
Figure 18	Lighting and Shutdown Instruction Label ..... 37
Figure 19	Top View of Gas Control ..... 38
Figure 20	Motor Connections..... 40
Figure 21	Motor Connections..... 41
Figure 22	Sequence of Operation – Electronic Blower Control ..... 42
Figure 23	Increasing Heating Speed ..... 43
Figure 24	Increasing Cooling Speed ..... 44
Figure 25	Speed Taps..... 44
Figure 26	Fan Blade..... 53
Figure 27	Low NOx Insert ..... 53

<b>TABLES</b>	<b>Page</b>
Table 1A	Specifications – W24-36G Models ..... 7
Table 1B	Specifications – W42-60G Models ..... 8
Table 2	Minimum Installation Clearances..... 18
Table 3	Low Voltage Connections for DDC Control ..... 22
Table 4	CO <sub>2</sub> Controllers ..... 23
Table 5	Thermostat Wire Size..... 23
Table 6	Wall Thermostats ..... 23
Table 7	Humidity Controls ..... 23
Table 8	Length of Standard Pipe Threads..... 28
Table 9	Gas Pipe Sizes – Natural Gas ..... 28
Table 10	Natural Gas Derate Capacities for All Models ..... 31
Table 11A	Natural Gas Orifice Tables – W24-36G ... 32
Table 11B	Natural Gas Orifice Tables – W42-60G ... 33
Table 12	W24G4 Indoor Blower Performance ..... 45
Table 13	W30G4 Indoor Blower Performance ..... 46
Table 14	W36G4 Indoor Blower Performance ..... 47
Table 15	W42G4 Indoor Blower Performance ..... 48
Table 16	W48G4 Indoor Blower Performance ..... 49
Table 17	W60G4 Indoor Blower Performance ..... 50
Table 18	Integrated Furnace and Blower Control Operation..... 51
Table 19	Cooling Pressure Table..... 52
Table 20	Fan Blade Dimension ..... 53

## Getting Other Information and Publications

---

These publications can help when installing the furnace. They can usually be found at the local library or purchased directly from the publisher. Be sure to consult the current edition of each standard.

National Fuel Gas Code ....ANSI Z223.1 / NFPA 54

National Electrical Code..... ANSI / NFPA 70

Standard for the Installation ..... ANSI / NFPA 90A  
of Air Conditioning and Ventilating Systems

Standard for Warm Air ..... ANSI / NFPA 90B  
Heating and Air Conditioning Systems

Standard for Chimneys, .....NFPA 211  
Fireplaces, Vents, and Solid Fuel Burning  
Appliances

Load Calculation for .....ACCA Manual J  
Residential Winter and Summer Air Conditioning

Duct Design for Residential ..... ACCA Manual D  
Winter and Winter Air Conditioning and Equipment  
Selection

Canadian Electrical Code.....CSA C22.1

Canadian Installation Code.....CAN/CGA B149

### For more information, contact these publishers:

**ACCA**      **Air Conditioning Contractors of America**  
1712 New Hampshire Avenue, NW  
Washington, DC 20009  
Telephone: (202) 483-9370

**ANSI**      **American National Standards Institute**  
11 West Street, 13th Floor  
New York, NY 10036  
Telephone: (212) 642-4900  
Fax: (212) 302-1286

**ASHRAE**    **American Society of Heating Refrigerating,  
and Air Conditioning Engineers, Inc.**  
1791 Tullie Circle, NE.  
Atlanta, GA 30329-2305  
Telephone: (404) 636-8400  
Fax: (404) 321-5478

**NFPA**      **National Fire Protection Association**  
Batterymarch Park  
P.O. Box 9101  
Quincy, MA 02269-9901  
Telephone: (800) 344-3555  
Fax: (617) 984-7057

**CSA**      **Canadian Standards Association**  
178 Rexdale Boulevard  
Rexdale, Ontario  
Canada. M9W 1R3  
Telephone: (416) 447-4044

BARD MANUFACTURING COMPANY, INC.  
BRYAN, OHIO 43506 USA

# WALL MOUNT GAS/ELECTRIC GENERAL INFORMATION

## MODEL NUMBER NOMENCLATURE

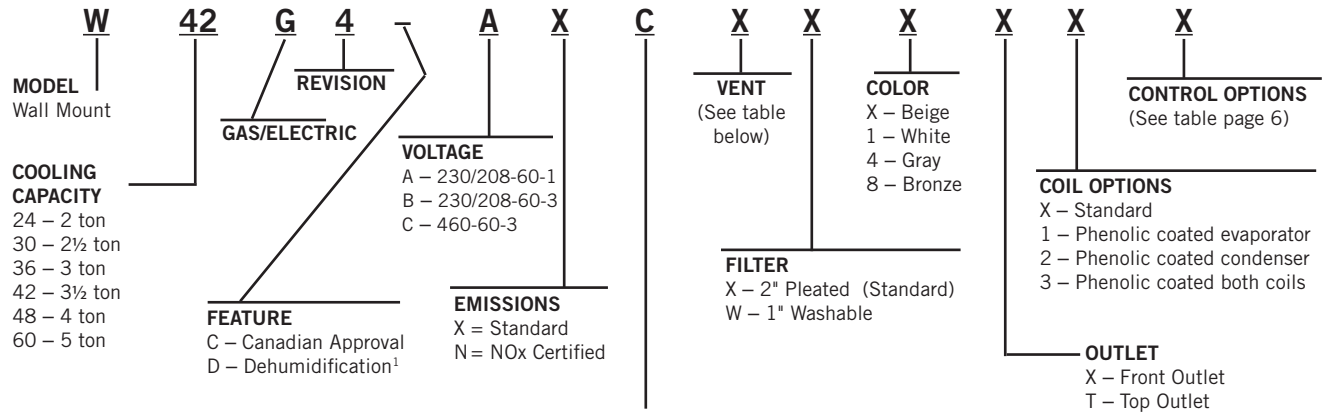

<sup>1</sup> Reference Supplemental Instructions 7960-867 for dehumidification unit information.

### Ventilation Options

		Models	
		W24G, W30G, W36G	W42G, W48G, W60G
Description	Factory Installed Code No.	Field Installed Part No.	Field Installed Part No.
Barometric Fresh Air Damper	X	WGBFAD-3	WGBFAD-5
Blank-Off Plate	B	WGBOP-3	WGBOP-5
Motorized Fresh Air Damper	M	WGMFAD-3A	WGMFAD-5A
Commercial Ventilator – Spring Return	V	WGCRVS-3A	WGCRVS-5A
Commercial Ventilator – Power Return	P	WGCRVP-3A	WGCRVP-5A
Economizer - Fully Modulating ①	E	WGJIFM-3	WGJIFM-5
Energy Recovery Ventilator – 230 Volt	R	WGERV-A3B	WGERV-A5B
Energy Recovery Ventilator – 460 Volt	R	WGERV-C3C	WGERV-C5C

① Low ambient control is required with economizer for low temperature compressor operation.

### Air Conditioning Module Options

CCM ①	HPC ②	LPC ③	LAC ④	SK ⑤	Factory Installed Code	Field Installed Part
STD	STD	STD	•		H	CMA-45 (WG4D Units) CMA-46 (WG4 Units)
				•	Field Only	SK111 or CMC-15

STD – Standard equipment.

- ① CCM Compressor control module has adjustable 30 second to 5 minute delay-on-break timer. On initial power up, or any time the power is interrupted, the delay-on-make will be 2 minutes plus 10% of the delay-on-break setting. There is no delay-on-make during routine operation of the unit. The module also provides the lockout feature (with 1 retry) for high and/or low pressure controls, and a 2-minute timed bypass for low pressure control.
- ② HPC High pressure control is auto reset. Always used with compressor control module (CCM) which is included. See Note ①.
- ③ LPC Low pressure control is auto reset. Always used with compressor control module (CCM) which is included. See Note ①.
- ④ LAC Low ambient control permits cooling operation down to 0°F. (Includes fan cycling control + Freeze Stat)
- ⑤ SK CMC-15 is PTCR Start Kit can be used with all -A single phase models. Increases starting torque 2-3X. Not used for -B or -C 3-phase models. Do not use if SK111 is used.
- ⑤ SK SK111 Start Capacitor and Potential Relay Start Kit can be used with all -A single phase models. Increases starting torque 9x. Not used for -B or -C 3-phase models. Do not use if CMC-15 is used.



**TABLE 1A**  
Specifications  
**W24G4, W30G4 and W36G4 Models**

<b>Models</b>	<b>W24G4-A</b>	<b>W24G4-B</b>	<b>W24G4-C</b>	<b>W30G4-A</b>	<b>W30G4-B</b>	<b>W30G4-C</b>	<b>W36G4-A</b>	<b>W36G4-B</b>	<b>W36G4-C</b>
<i>Electrical Rating – 60 Hz</i>	230/208-1	230/208-3	460-3	230/208-1	230/208-3	460-3	230/208-1	230/208-3	460-3
<i>Operating Voltage Range</i>	197-253	187-253	414-506	197-253	187-253	414-506	197-253	187-253	414-506
<i>Minimum Circuit Ampacity</i>	20.6	12.6	8	22.6	16.1	8.6	26.4	19	10.6
<i>* Field Wire Size</i>	10	14	14	10	12	14	8	10	14
<i>Ground Wire Size</i>	10	14	14	10	12	14	10	10	14
<i>** Delay Fuse or Circuit Breaker Max.</i>	30	15	10	30	20	10	35	25	15
<i>Compressor</i>									
<i>Voltage</i>	230/208	230/208	460	230/208	230/208	460	230/208	230/208	460
<i>Rated Load Amps</i>	7.6/8.7	4.6/5.3	2.5	9.4/10.7	6/6.9	3.2	12/13.5	7.8/8.7	4.8
<i>Branch Circuit Selection Current</i>	12.9	6.5	3.6	14.2	9	4.2	16.7	10.5	5.8
<i>Lock Rotor Amps</i>	58.3	55.4	28	73	58	28	79	73	38
<i>Compressor Type</i>	Scroll	Scroll	Scroll	Scroll	Scroll	Scroll	Scroll	Scroll	Scroll
<i>Fan Motor and Condenser</i>									
<i>Fan Motor – HP/RPM/SPD</i>	1/5-1100-1	1/5-1100-1	1/5-1100-1	1/5-1100-1	1/5-1100-1	1/5-1100-1	1/5-1100-1	1/5-1100-1	1/5-1100-1
<i>Fan Motor – Amps</i>	1.4	1.4	0.8	1.4	1.4	0.8	1.4	1.4	0.8
<i>Fan – DIA/CFM</i>	20" - 2100	20" - 2100	20" - 2100	20" - 2100	20" - 2100	20" - 2100	20" - 2000	20" - 2000	20" - 2000
<i>Blower Motor and Evaporator</i>									
<i>Blower Motor – HP/RPM/SPD</i>	1/2-670-5	1/2-670-5	1/2-670-5	1/2-750-5	1/2-750-5	1/2-750-5	1/2-870-5	1/2-870-5	1/2-870-5
<i>Blower Motor – Amps</i>	0.9	0.9	1.2	1.2	1.2	1.2	1.9	1.9	1.2
<i>CFM Cooling and E.S.P.</i>	800 - 0.15	800 - 0.15	800 - 0.15	900 - 0.15	900 - 0.15	900 - 0.15	1100 - 0.15	1100 - 0.15	1100 - 0.15
<i>Filter Size</i>	20 x 25 x 2	20 x 25 x 2	20 x 25 x 2	20 x 25 x 2	20 x 25 x 2	20 x 25 x 2	20 x 25 x 2	20 x 25 x 2	20 x 25 x 2
<i>Shipping Weight – LBS.</i>	500	500	500	530	530	530	540	540	540
<i>Unit Charge (R-410A lb.)</i>	5.750	5.750	5.750	5.750	5.750	5.750	6.625	6.625	6.625

\* 75° C Copper wire size

\*\* Maximum time delay fuse or circuit breaker

**TABLE 1B**  
**Specifications**  
**W42G, W48G and W60G Models**

Models	W42G4-A	W42G4-B	W42G4-C	W48G4-A	W48G4-B	W48G4-C	W60G4-A	W60G4-B	W60G4-C
<i>Electrical Rating – 60 Hz</i>	230/208-1	230/208-3	460-3	230/208-1	230/208-3	460-3	230/208-1	230/208-3	460-3
<i>Operating Voltage Range</i>	197-253	187-253	414-506	197-253	187-253	414-506	197-253	187-253	414-506
<i>Minimum Circuit Ampacity</i>	29	23.4	11.5	34.4	24.4	12	40.2	29.7	13.6
<i>* Field Wire Size</i>	8	10	14	8	10	14	8	8	12
<i>Ground Wire Size</i>	10	10	14	10	10	14	10	10	12
<i>** Delay Fuse or Circuit Breaker Max.</i>	40	30	15	50	30	15	50	40	20
<i>Compressor</i>									
<i>Voltage</i>	230/208	230/208	460	230/208	230/208	460	230/208	230/208	460
<i>Rated Load Amps</i>	15.5/17.4	11.7/13.2	5.9	16.7/19.5	10.6/12.3	6.5	19.5/21.9	12.9/14.4	7
<i>Branch Circuit Selection Current</i>	18	13.6	6	21.8	13.8	6.5	24.4	16	7.8
<i>Lock Rotor Amps</i>	112	88	44	117	83.1	41	144.2	110	52
<i>Compressor Type</i>	Scroll	Scroll	Scroll	Scroll	Scroll	Scroll	Scroll	Scroll	Scroll
<i>Fan Motor and Condenser</i>									
<i>Fan Motor – HP/RPM/SPD</i>	1/3-850-1	1/3-850-1	1/3-850-1	1/3-830-1	1/3-830-1	1/3-830-1	1/2-1000-1	1/2-1000-1	1/2-1000-1
<i>Fan Motor – Amps</i>	1.8	1.8	1	1.8	1.8	1	3.8	3.8	2.5
<i>Fan – DIACFM</i>	24" - 2900	24" - 2900	24" - 2900	24" - 2700	24" - 2700	24" - 2700	24" - 3400	24" - 3400	24" - 3400
<i>Blower Motor and Evaporator</i>									
<i>Blower Motor – HP/RPM/SPD</i>	3/4-850-5	3/4-850-5	3/4-850-5	3/4-940-5	3/4-940-5	3/4-940-5	3/4-1040-5	3/4-1040-5	3/4-1040-5
<i>Blower Motor – Amps</i>	2.4	2.4	1.7	3.1	3.1	1.7	3.7	3.7	1.7
<i>CFM Cooling and E.S.P.</i>	1300 - 0.15	1300 - 0.15	1300 - 0.15	1450 - 0.20	1450 - 0.20	1450 - 0.20	1650 - 0.20	1650 - 0.20	1650 - 0.20
<i>Filter Size</i>	20 x 30 x 2	20 x 30 x 2	20 x 30 x 2	20 x 30 x 2	20 x 30 x 2	20 x 30 x 2	20 x 30 x 2	20 x 30 x 2	20 x 30 x 2
<i>Shipping Weight – LBS.</i>	500	500	500	530	530	530	550	550	550
<i>Unit Charge (R-410A lb.)</i>	6.500	6.500	6.500	7.125	7.125	7.125	9.625	9.625	9.625

\* 75° C Copper wire size

\*\* Maximum time delay fuse or circuit breaker

**FIGURE 1**  
Unit Dimensions

UNIT	A	B	C	D	E	F	G	H	I	J	K	L	M	N	O	P	Q	R
W24G-W30G-W36G	7.88	27.88	13.88	24.25	40	14.88	25.63	81.63	30	27.38	27.5	14.12	15.44	15.31	39.25	4.5	2.5	5.88
W42G-W48G-W60G	9.88	29.88	15.88	27.25	43.81	31.63	87.5			33.38	28.75		40.25		42.88			3.75
UNIT	S	T	U	V	W	X	Y	Z	AA	BB	CC	DD	EE	FF	GG	HH	II	
W24G-W30G-W36G	12 - 7 HOLES	3.75	2.88	22.9	38	17.84	4.44	2.25	11.44	3.25	9	7.25	36.25	1.13	1.25	2	0.38	
W42G-W48G-W60G	16 - 6 HOLES		3.88	24.9	42	17.34	8.44		12.19	10	10		40.25		2.75	0.44		

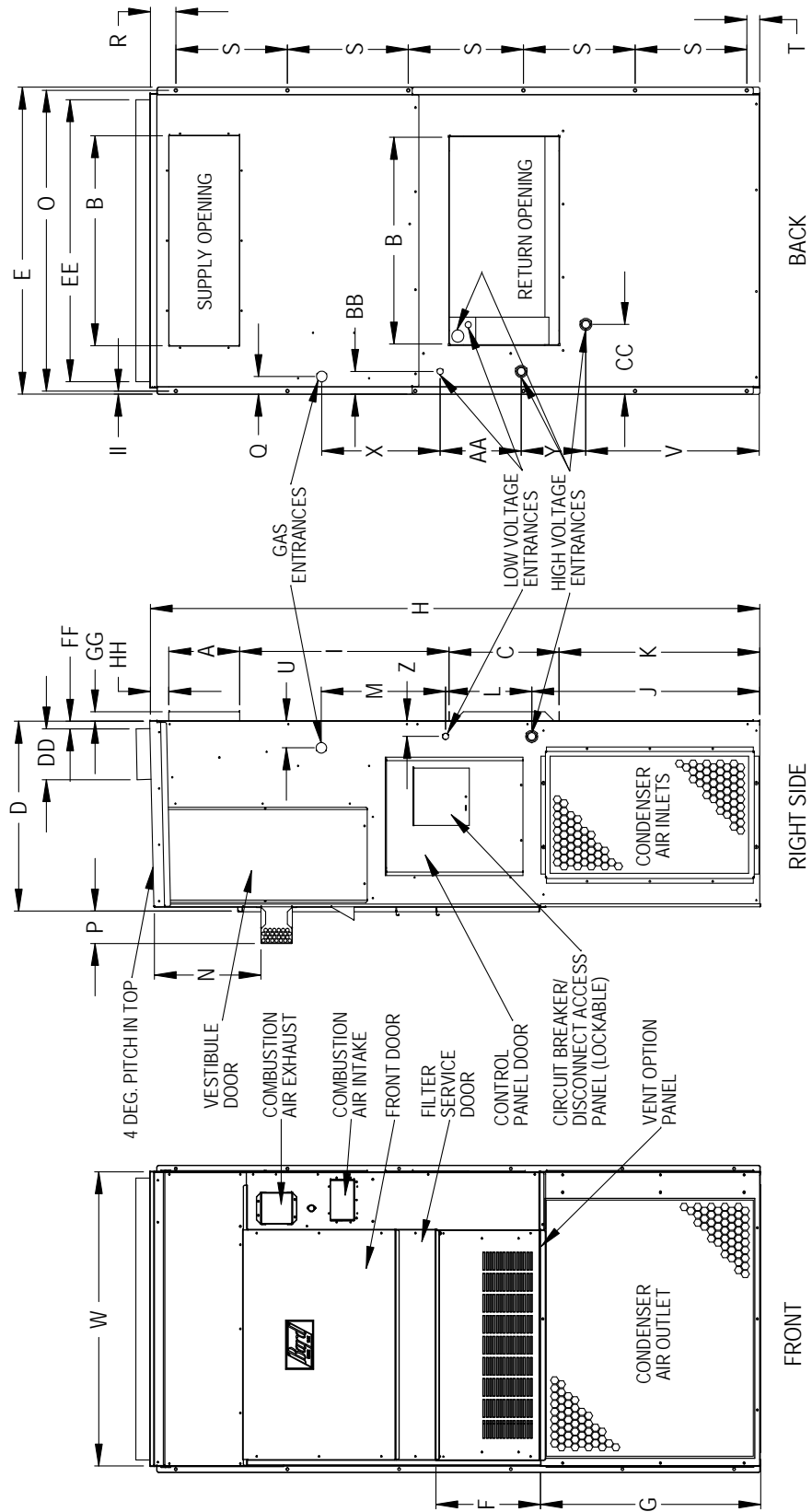

MIS-3239



# CAUTION

During the initial firing of the burners there will probably be some amount of smoke issued to the circulating air stream as the result of residual oil burning off of the heat exchanger tubes. This oil is required during the forming process of the stainless steel heat exchanger tubes to facilitate the bending. OSHA or the National Toxicology Program does not list the oil as a carcinogen. In vapor form this may be irritating to the eyes or could cause headaches. This is a one-time occurrence, and ventilation of the space may be required depending upon the space being conditioned.

## 1. TRANSPORTATION DAMAGE

All units are packed securely in shipping containers. All units should be carefully inspected upon arrival for damage. In the event of damage, the consignee should:

1. Note on delivery receipt of any damage to container.
2. Notify carrier promptly, and request an inspection.
3. In case of concealed damage, the carrier must be notified as soon as possible within 15 days after delivery.
4. Claims for any damage, apparent or concealed, should be filed with the carrier, using the following supporting documents:
  - A. Original Bill of Lading, certified copy or indemnity bond.
  - B. Original paid freight bill of indemnity in lieu thereof.
  - C. Original invoice or certified copy thereof showing trade and other discounts or deductions.
  - D. Copy of the inspection report issued by carrier's representative at the time damage is reported to carrier.

## 2. IMPORTANT

The equipment covered in this manual is to be installed by trained, experienced service and installation technicians. All duct work or portions thereof not in the conditioned space should be properly insulated in order to both conserve energy and prevent condensation or moisture damage.

## 3. GENERAL INFORMATION

This appliance is not intended for use by persons (including children) with reduced physical, sensory or mental capabilities, or lack of experience and knowledge, unless they have been given supervision or instruction concerning use of the appliance by a person responsible for their safety.

Children should be supervised to ensure that they do not play with the appliance.

These instructions explain the recommended method to install the air cooled self-contained electric air

conditioning and gas heating unit and the electrical wiring connections and gas piping to the unit. The refrigerant system is completely assembled and charged. All internal wiring is complete.

These instructions and any instructions packaged with any separate equipment required to make up the entire heating/cooling system should be carefully read before beginning the installation.

While these instructions are intended as a general recommended guide, they do not supersede any national and/or local codes in any way. Authorities having jurisdiction should be consulted before the installation is made. See page 4 for information on codes and standards.

Size of unit for proposed installation should be based on heat loss/heat gain calculations made according to methods of Air Conditioning Contractors of America (ACCA). The air duct should be installed in accordance with the Standards of the National Fire Protection Association for the Installation of Air Conditioning and Ventilating Systems of Other Than Residence Type, NFPA No. 90A, and Residence Type Warm Air Heating and Air Conditioning Systems, NFPA No. 90B. Where local regulations are at a variance with instructions, installer should adhere to local codes.

## 4. APPLICATION

This is a fan-assisted forced air gas furnace with electric air conditioning for outdoor installation. A fan-assisted furnace is equipped with an integral mechanical means to draw products of combustion through the combustion chamber and heat exchanger. The furnace installation must conform with local building codes and ordinances or, in their absence, with the National Fuel Gas Code ANSI Z223.1 or CAN/CGA-B149.1, latest edition, and the National Electrical Code ANSI/NFPA-7 or CSA C22.1, latest edition. It is the personal responsibility and obligation of the purchaser to contact a qualified installer to assure that installation is adequate and is in conformance with governing codes and ordinances.

## 5. DUCT WORK

The unit is designed for use with or without duct work (see **WARNING**). Flanges are provided for attaching

the supply and return ducts. All duct work, supply and return, must be properly sized for the design airflow requirement of the equipment. Air Conditioning Contractors of America (ACCA) is an excellent guide to proper sizing.

 <b>WARNING</b>
In all cases, there must be a metal duct connection made to the supply air flange, and a 1" clearance to combustibles must be maintained to this duct connection.
For free blow applications, a metal sleeve must be used in the wall opening itself, again maintaining a 1" clearance to combustibles.
Failure to use the sheet metal can cause fire resulting in property damage, injury, or death.

Refer to Tables 12, 13, 14, 15, 16 and 17 for maximum static pressure available for duct design.

See Figures 3A and 3B and clearance information in Section 9 and Table 2 for additional information.

Design the duct work according to methods given by the Air Conditioning Contractors of America (ACCA). When duct runs through unheated spaces, it should be insulated with a minimum of one-inch of insulation. Use insulation with a vapor barrier on the outside of the insulation. Flexible joints should be used to connect the duct work to the equipment in order to keep the noise transmission to a minimum.

A 1" clearance to combustible material for the first 3' of duct attached to the outlet air frame is required. See wall mounting instructions and Figures 2A, 2B, 3A and 3B for further details.

Ducts through the walls must be insulated and all joints taped or sealed to prevent air or moisture entering the wall cavity.

Some installations may not require any return air duct. A metallic return air grille is required with installations not requiring a return air duct. The spacing between louvers on the grille shall not be larger than 5/8".

Any grille that meets with the 5/8" louver criteria may be used. It is recommended that Bard Return Air Grille or Return Filter Grille be installed when no return duct is used. Contact distributor or factory for ordering information. If using a return air filter grille, filters must be of sufficient size to allow a maximum velocity of 400 fpm.

*NOTE: If no return air duct is used, applicable installation codes may limit this cabinet to installation only in a single story structure.*

## 6. HIGH ALTITUDE APPLICATIONS

Ratings of gas utilization equipment are based on sea level operation and need not be changed for operation at elevations up to 6,000'. For operation at elevations above 6,000' and in the absence of specific recommendations from the local authority having jurisdiction, equipment ratings shall be reduced as specified in Section 21.

## 7. WALL MOUNTING INFORMATION

1. Two holes for the supply and return air openings must be cut through the wall as detailed in Figure 4.
2. On wood-frame walls, the wall construction must be strong and rigid enough to carry the weight of the unit without transmitting any unit vibration.
3. Concrete block walls must be thoroughly inspected to ensure that they are capable of carrying the weight of the installed unit.

## 8. MOUNTING THE UNIT

1. These units are secured by wall mounting brackets which secure the unit to the outside wall surface at both sides. A bottom mounting bracket is provided for ease of installation but is not required.

 <b>CAUTION</b>
If the bottom bracket is used, be certain the bracket is secured to the outside wall surface in a way sufficient to support the entire weight of the unit during installation until side mounting brackets are secured.

2. The W42G, W48G and W60G models are suitable for 0 clearance on the installation mounting wall and to the top. For all models the supply air duct flange and the first 3' of supply air duct require a minimum of 1" clearance to combustible material. The W24G, W30G and W36G models are suitable for 0 clearance on the installation mounting wall, but require 1" clearance to the top if combustible material overhang projects above the unit (see Figures 3A and 3B). If a combustible wall, use a minimum of Figure 1 "A" dimension plus 2" and "B" dimension plus 2". See Figures 4 and 5 for details.

 <b>WARNING</b>
Failure to provide the 1" clearance between the supply duct and a combustible surface for the first 3' of duct can result in fire causing damage, injury or death.

3. Locate and mark lag bolt locations and bottom mounting bracket location.
4. Mount bottom mounting bracket.
5. Hook top rain flashing under back bend of top. Top rain flashing is shipped secured to the right side of the back.
6. Position unit in opening and secure with 5/16" lag bolts; use 7/8" diameter flat washers on the lag bolts. Use lag bolts long enough to support the unit's weight when mounted to the structure. This length may be dependent on the type of construction.
7. Secure rain flashing to wall and caulk across entire length of top (see Figures 2A and 2B).
8. On side-by-side installations, maintain a minimum of 20" clearance on right side to allow access to control panel and burner compartment, and to allow proper airflow to the outdoor coil. Additional clearance may be required to meet local or national codes.

**FIGURE 2A**  
**Mounting Instructions**  
**for W24G, W30G and W36G**

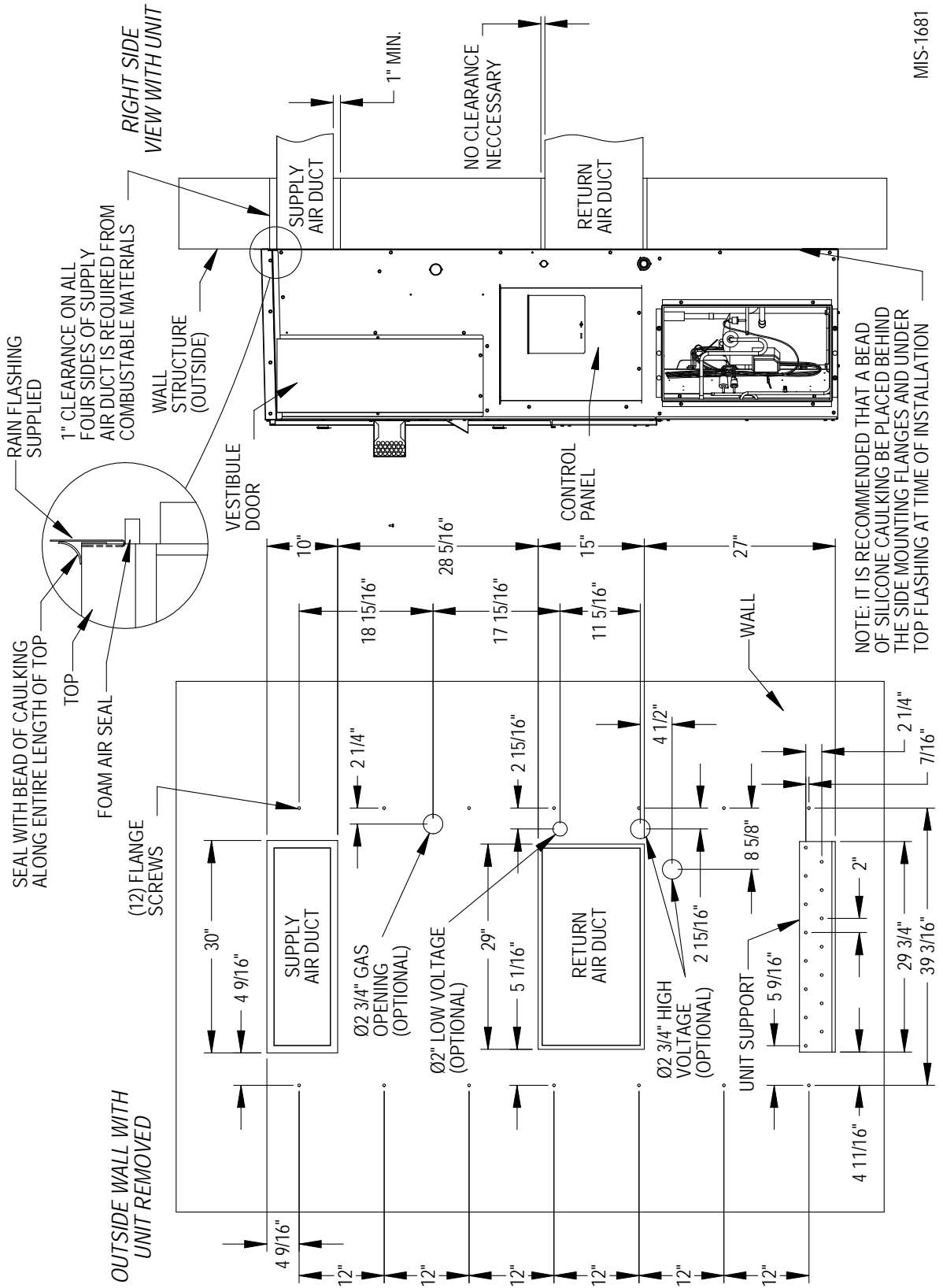

MIS-1681

**FIGURE 2B**  
**Mounting Instructions**  
**for W42G, W48G and W60G**

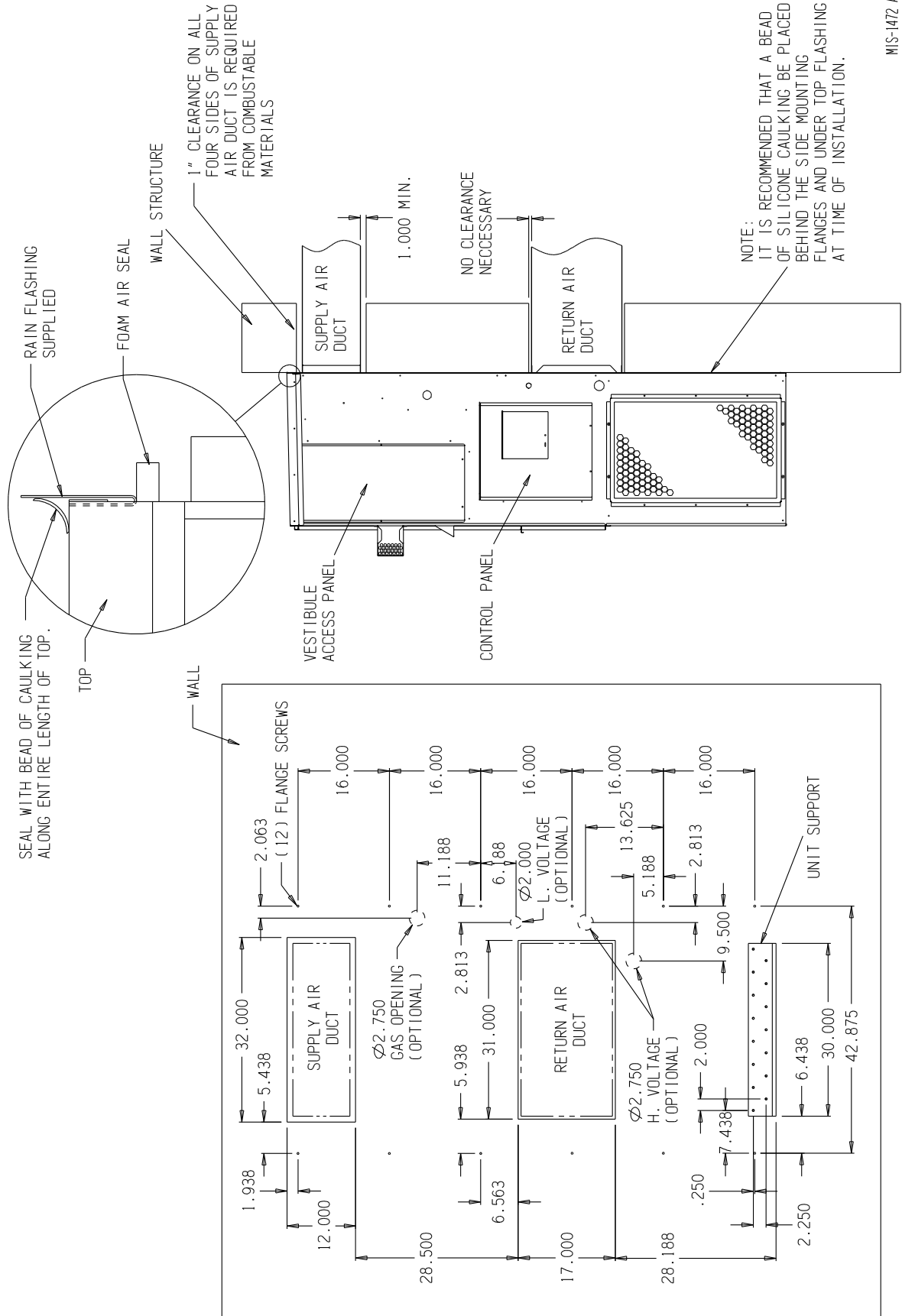



**FIGURE 3A**  
**Combustible Clearance**  
**for W24G, W30G and W36G Models**

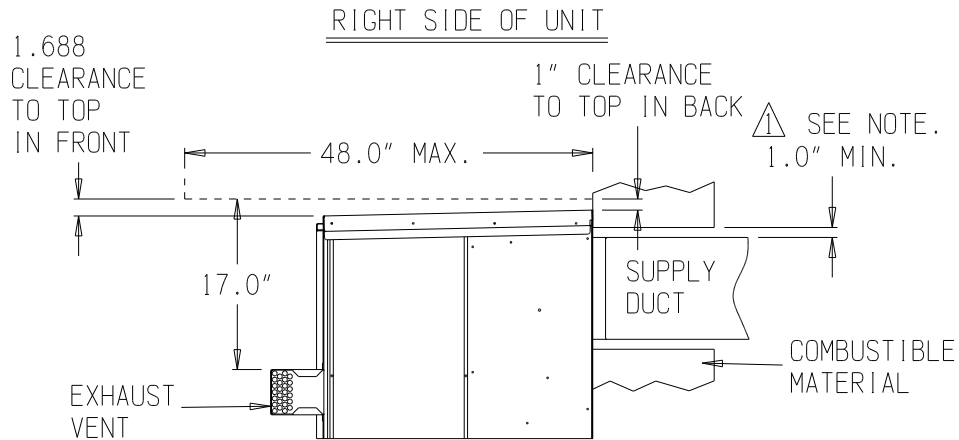

⚠ SIDE SECTION VIEW OF SUPPLY AIR DUCT  
 FOR WALL MOUNTED UNIT SHOWING 1.0"  
 CLEARANCE TO ALL COMBUSTIBLE SURFACES.

MIS-1682

**FIGURE 3B**  
**Combustible Clearance**  
**for W42G, W48G and W60G Models**

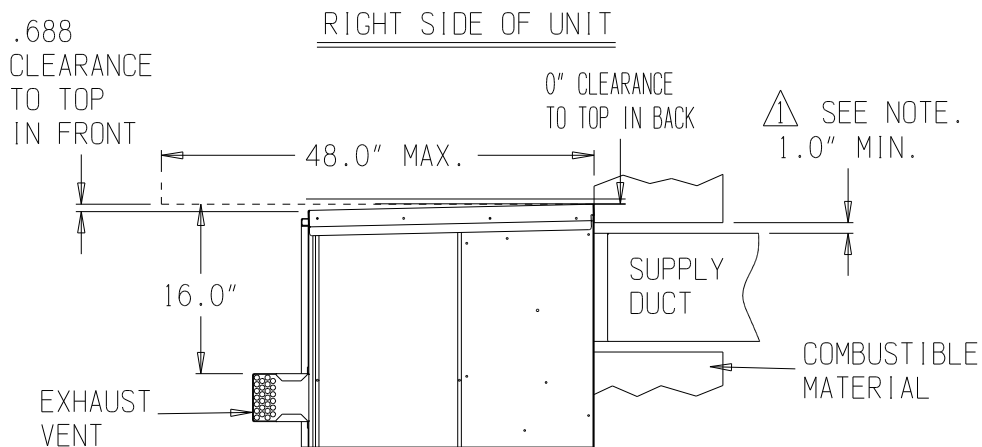

⚠ SIDE SECTION VIEW OF SUPPLY AIR DUCT  
 FOR WALL MOUNTED UNIT SHOWING 1.0"  
 CLEARANCE TO ALL COMBUSTIBLE SURFACES.

MIS-1714



## WARNING

A **minimum** of 1" clearance must be maintained between the supply air duct and combustible materials. This is required for the first 3' of ducting.

It is important to insure that the one 1" minimum spacing is maintained at all points.

Failure to do this could result in overheating the combustible material and may result in a fire causing damage, injury or death.

**FIGURE 4**  
**Wall Mounting Instructions**

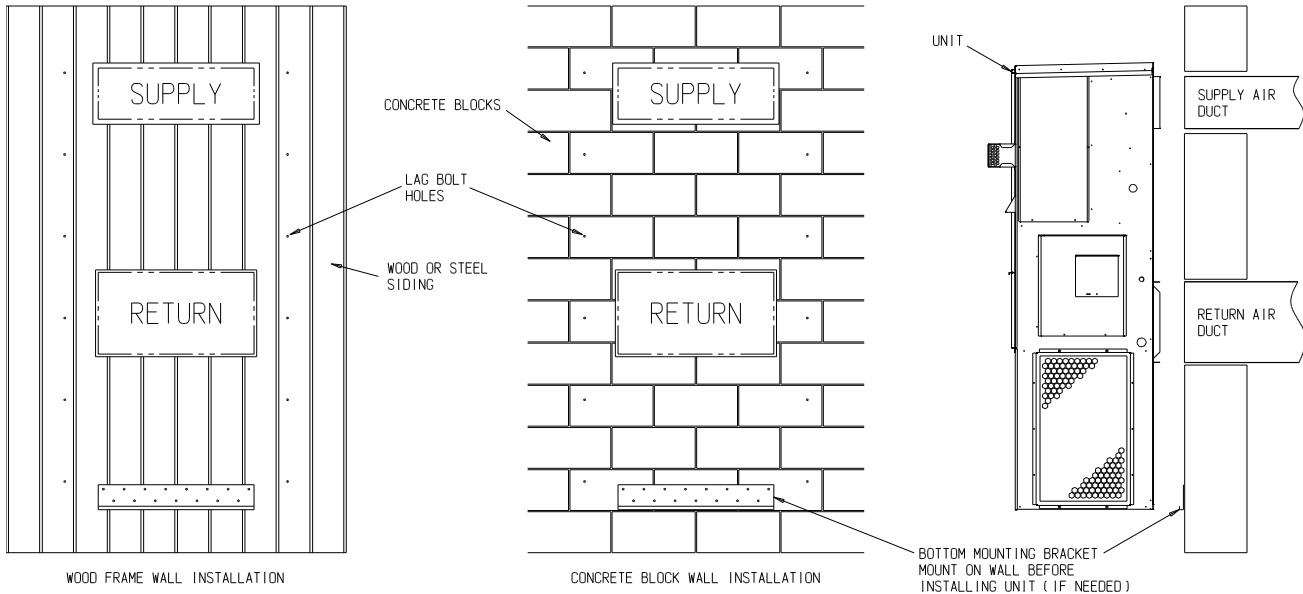

MIS-1475

**FIGURE 5**  
**Wall Mounting Instructions**

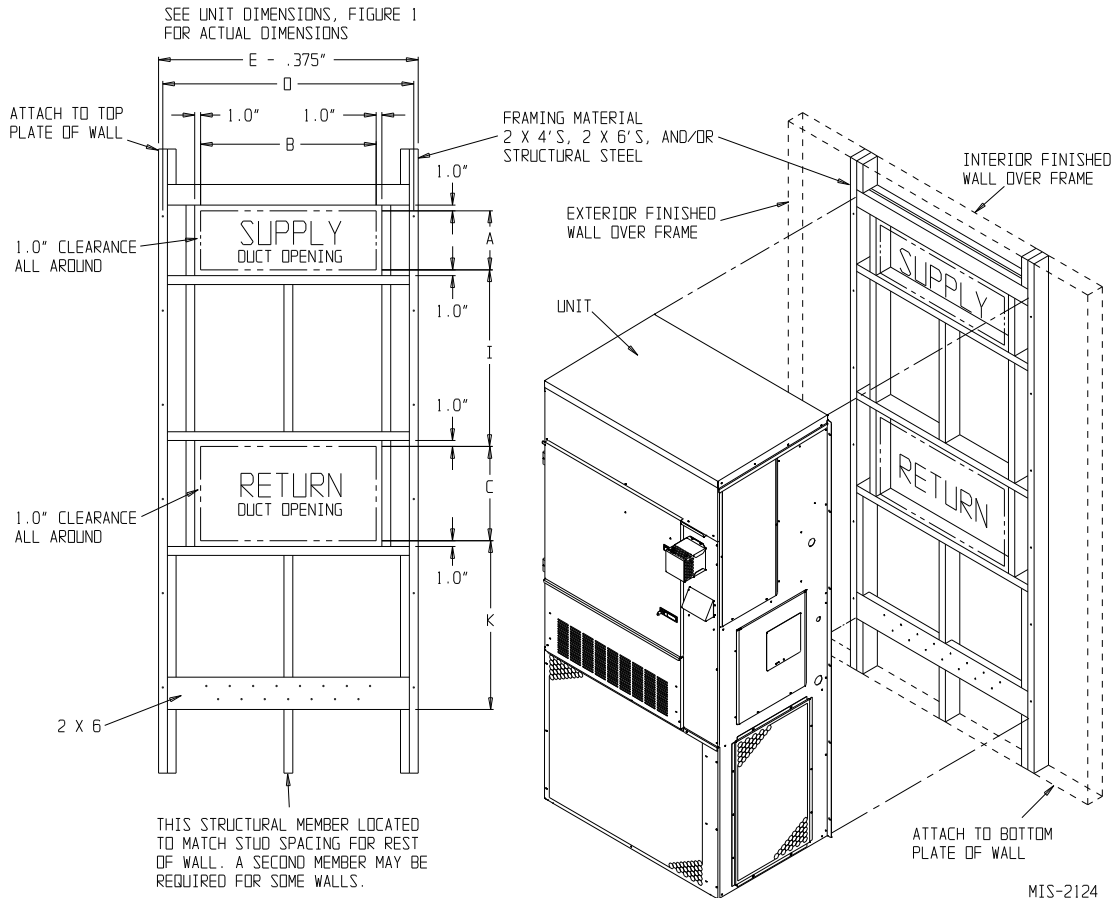

MIS-2124

**FIGURE 6**  
**Common Wall Mounting Installations**

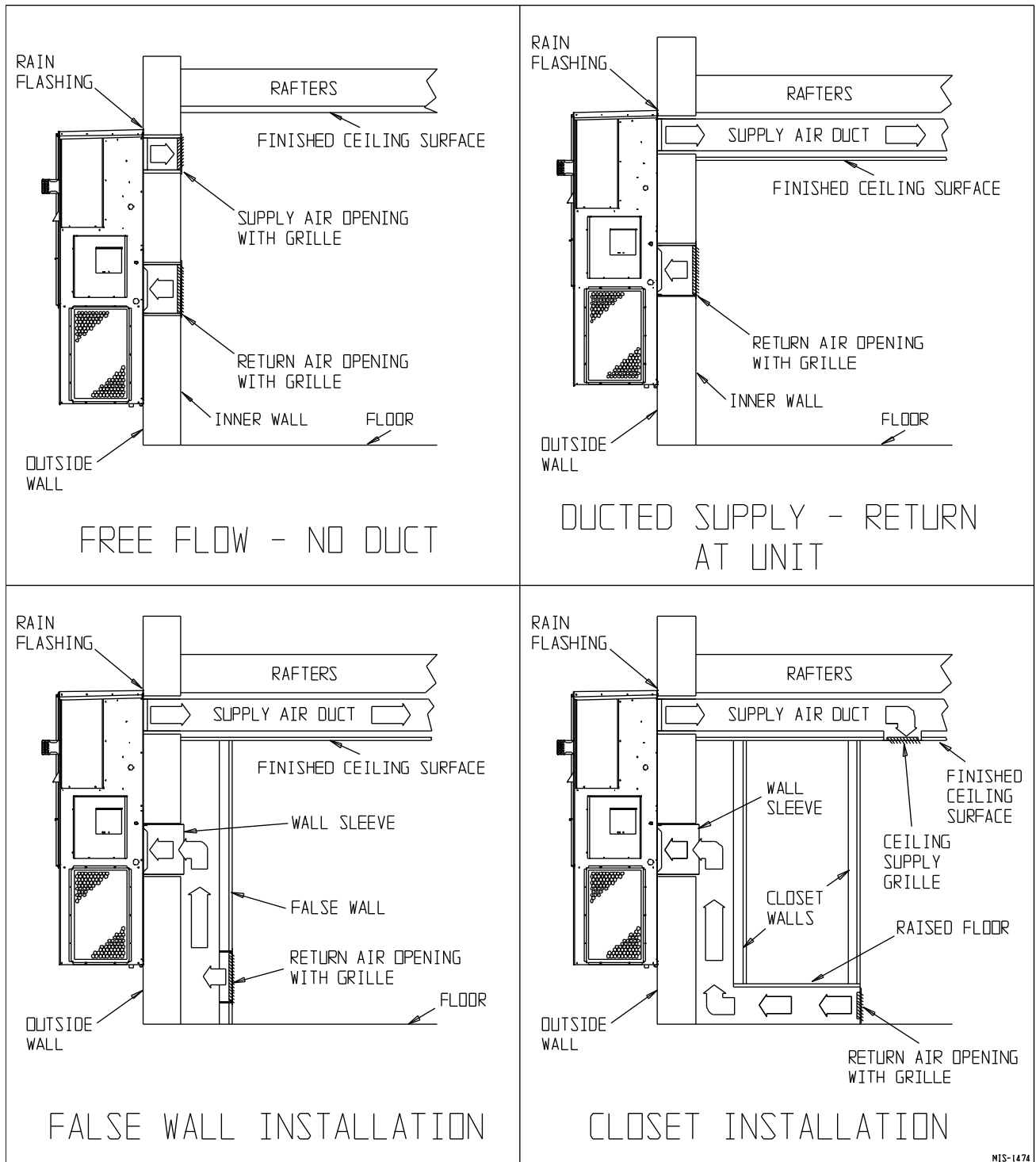

HIS-1474

## 9. CLEARANCES

Minimum clearances, as specified in Table 2, must be maintained from adjacent structures to provide adequate fire protection, adequate combustion air and room for service personnel.

While minimum clearances are acceptable for safety reasons, they may not allow adequate air circulation around the unit for proper operation in the cooling mode. Whenever possible, it is desirable to allow additional clearance, especially around the condenser inlet and discharge openings. DO NOT install the unit in a location that will permit discharged air from the condenser to recirculate to the condenser inlet.

### **WARNING**

Clearances from combustible materials must be maintained as specified. Failure to maintain clearances could cause fire resulting in property damage, injury or death.

**TABLE 2**  
**Minimum Installation Clearances**

Outlet Duct (from combustible materials)	1" first 3'
Vent Terminal (from combustible materials)	17"*
Condenser Inlet	20"
Top	See Figures 3A and 3B
Burner Service	20"
Combustible Base (Wood or Class A, B or C roof covering material)	0
* See Figures 3A and 3B	

**FIGURE 7**  
**Location of Vent Terminal in Shipping**

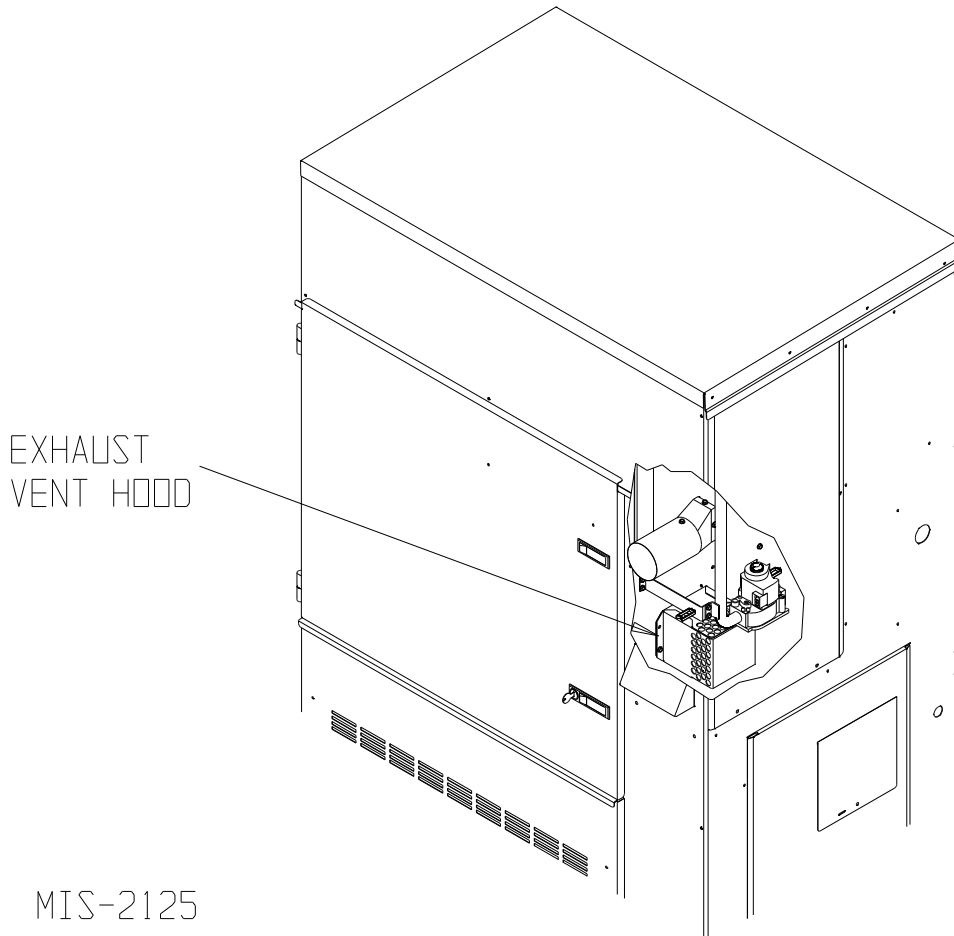

## 10. VENT TERMINAL AND COMBUSTION AIR INLET HOOD

The vent terminal is shipped in the burner compartment (see Figure 7). Remove the two shipping screws and separate the two-piece assembly. Install the vent terminal by using the four screws provided.

**Do not cut or trim gasket. Make sure gasket is in place.** See Figure 8. The combustion air intake vent hood is factory installed.

## 11. OPTIONAL VERTICAL VENTING

With the optional vertical venting kit (VVK-5), this unit may be vented vertically through a roof or overhang. The kit includes a stainless steel transition drain tee, silicone sealant and drain tubing.

If unit is installed with vertical vent kit, annually inspect the vent system and drain. Replace any portion of the vent system that shows signs of deterioration. Make sure drain is open and free of obstruction.



# CAUTION

Vent terminal must be installed as shown in Figure 8 for proper operation of the heating system.

**NOTE: The inner vent hood gasket is designed to stretch over and seal around the combustion air blower outlet. This is a very critical seal to prevent water and flue products from entering the unit. Care must be taken to insure this gasket is in place and sealing properly.**

**FIGURE 8**  
Vent Terminal and Combustion Air Intake

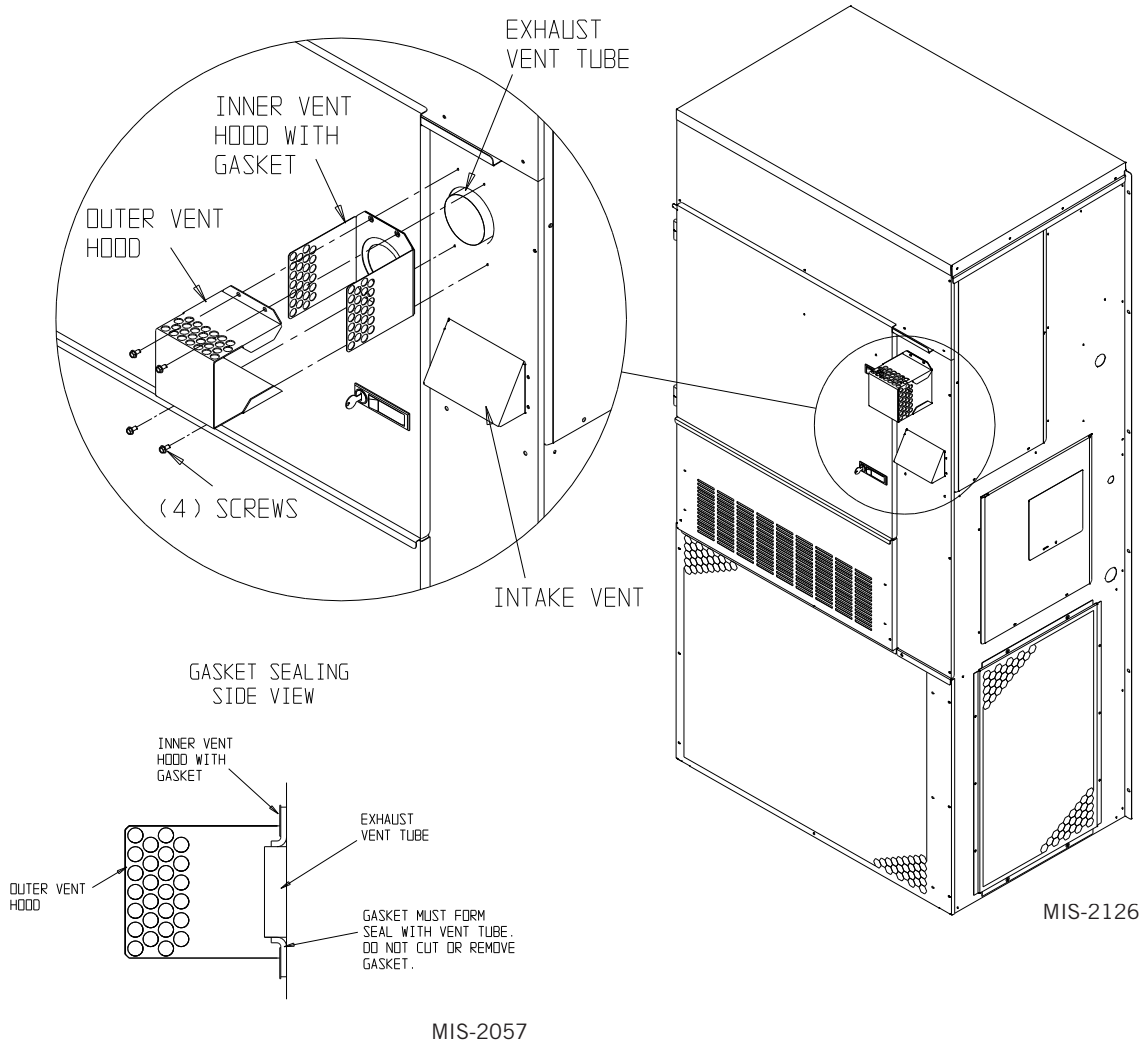

## 12. VENT RESIZING INSTRUCTIONS

When an existing furnace is removed from a venting system servicing other appliances, the venting system is likely to be too large to properly vent the remaining attached appliances.

The following steps shall be followed with each of the appliances remaining connected to the common venting system, placed in operation one at a time while the other appliances remaining connected to the common venting system are not in operation.

1. Seal any unused openings in the venting system.
2. Inspect the venting system for proper size and horizontal pitch, as required in the National Fuel Gas code, ANSI Z223.1 or the CAN/CGA B149 Installation Codes and these instructions. Determine that there is no blockage or restriction, leakage, corrosion and other deficiencies which could cause an unsafe condition.
3. In so far as is practical, close all building doors and windows and all doors between the space in which the appliance(s) connected to the venting system are located and other spaces of the building. Turn on clothes dryers and any appliances not connected to the venting system. Turn on any exhaust fans, such as range hoods and bathroom exhausts, so they will operate at maximum speed. Do not operate a summer exhaust fan. Close fireplace dampers.
4. Follow the lighting instructions. Place the appliance being inspected in operation. Adjust thermostat so appliance shall operate continuously.
5. Test for draft hood equipped appliance spillage at the draft hood relief opening after 5 minutes of main burner operation. Use the flame of a match or candle.
6. After it has been determined that each appliance connected to the venting system properly vents when tested as outlined above, return doors, windows, exhaust fans, fireplace dampers and any other gas-burning appliances to their previous conditions of use.
7. If improper venting is observed during any of the above tests, the venting system must be corrected.

## 13. FRESH AIR INTAKE

All units are built with fresh air inlet slots punched in the service panel.

If the unit is equipped with a fresh air damper assembly, the assembly is shipped already attached to the unit. The damper blade is locked in the closed position. To allow the damper to operate, the maximum and minimum blade position stops must be installed (see Figure 9).

All capacity, efficiency and cost of operation information as required for Department of Energy

**FIGURE 9**  
**Fresh Air Damper**

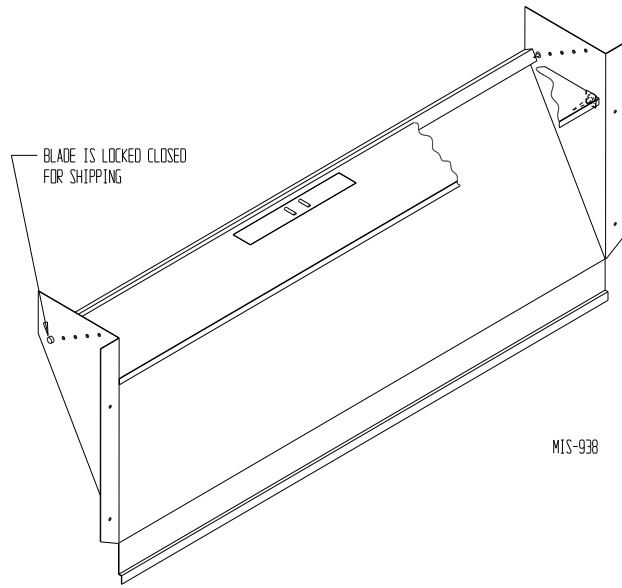

“Energyguide” Fact Sheets is based upon the fresh air blank-off plate in place and is recommended for maximum energy efficiency.

The blank-off plate is available upon request from the factory and is installed in place of the fresh air damper shipped with each unit.

One of several other ventilation options may be installed. Refer to model number and/or supplemental installation instructions.

## 14. CONDENSATE DRAIN

A plastic drain hose extends from the drain pan at the top of the unit down to the unit base. There are openings in the unit base for the drain hose to pass through. In the event the drain hose is connected to a drain system of some type, it must be an open or vented type system to assure proper drainage.

## 15. WIRING – MAIN POWER

### **WARNING**

For personal safety, turn off electric power at service entrance panel before making any electrical connections. Failure to do so could result in electric shock or fire.

Refer to unit rating plate for wire sizing information and maximum fuse or circuit breaker size. Each outdoor unit is marked with a “Minimum Circuit Ampacity”. This means that the field wiring used must be sized to carry that amount of current. All models are suitable only for connection with copper wire. Each unit and/or

wiring diagram will be marked “Use Copper Conductors Only”. These instructions **must be** adhered to. Refer to the National Electrical Code (NEC) for complete current carrying capacity data on the various insulation grades of wiring material. All wiring must conform to NEC and all local codes.

The electrical data lists fuse and wire sizes (75° C copper) for all models.

The unit rating plate lists a “Maximum Time Delay Relay Fuse” or circuit breaker that is to be used with the equipment. The correct size must be used for proper circuit protection and also to assure that there will be no nuisance tripping due to the momentary high starting current of the compressor motor.

The disconnect access door on this unit may be locked to prevent unauthorized access to the disconnect. To convert for the locking capability bend the tab located in the bottom left hand corner of the disconnect opening under the disconnect access panel straight out. This tab will now line up with the slot in the door. When shut, a padlock may be placed through the hole in the tab preventing entry.

**WARNING**

Failure to provide an electrical power supply shut off means could result in electric shock or fire.

### Electrical Grounding

When installed, the furnace must be electrically grounded in accordance with local codes, or in the absence of local codes, with the National Electrical Code, ANSI/NFPA 70 or Canadian Electrical Code, CSA22.1, latest edition. Use a copper wire from green ground wire on the furnace to a grounded connection in the service panel or a properly driven and electrically grounded ground rod. See Tables 1A and 1B for proper ground wire size.

**WARNING**

Failure to provide a proper electrical ground could result in electric shock or fire.

### Field-Installed Equipment

Wiring to be done in the field between the furnace and devices not attached to the furnace, or between separate devices which are field installed and located, shall conform with the temperature limitation for Type T wire {63° F rise (36° C)} when installed in accordance with the manufacturer’s instructions.

### Installation of Flexible Conduit Through Return Air Opening

**NOTE:** To allow proper clearance between the control panel and any vent options, 90° conduit fittings must be used on the back of the control panel.

**Installing Conduit** (See Figure 10)

1. Remove conduit access panel if required to gain access to area behind control panel.
2. Remove low voltage and high voltage knockouts located in rear of control panel.
3. Run low voltage conduit through 7/8 bushing located in conduit entrance plate and secure to low voltage opening in rear of control panel.
4. Run high voltage conduit through 1-3/4 bushing located in conduit entrance plate and secure to high voltage opening in rear of control panel.
5. Replace conduit access panel if required to complete installation.
6. Seal around conduit in conduit entrance plate.

**FIGURE 10**  
Installation of Flexible Conduit

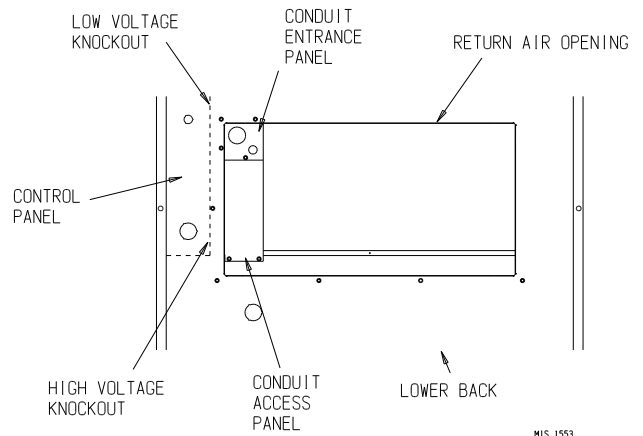

## 16. WIRING – LOW VOLTAGE WIRING

### 230/208 Volt Units

All 230/208V 1 phase and 3 phase equipment have dual primary voltage transformers. All equipment leaves the factory wired on 240V tap. For 208V operation, reconnect from 240V to 208V tap. The acceptable operating voltage range for the 240 and 208V taps are:

Tap: 240      Range: 253 – 216

Tap: 208      Range: 220 – 187

**NOTE:** The voltage should be measured at the field power connection point in the unit and while the unit is operating at full load (maximum amperage operating condition).

For low voltage wiring, an 18 gauge copper, color-coded cable is recommended. See Table 5 for more information.

### 460 Volt Units

All models are equipped with single primary voltage transformers and no rewiring is required.

### Direct Digital Controls (DDC)

For total and proper control using DDC, a total of six controlled outputs are required (five if no ventilation is installed).

**TABLE 3**  
**Low Voltage Connections for DDC Control**

	Standard Units	Units w/ Economizers
Fan Only	Energize G	Energize G
1st Stage Cooling Mode/Balanced Climate	Energize Y1, G	Energize Y1, G
2nd Stage Cooling Mode	Energize Y2 to override Balanced Climate mode when Y1-Y2 jumper is removed	Energize Y1, Y2, G
Gas Heating	Energize B/W1	Energize B/W1
Ventilation	Energize A	Energize A
Dehumidification (if employed)	Energize D	Energize D

### Low Voltage (24VAC) Connections

These units use a 24-volt AC low voltage circuit.

**C** terminal is the *24VAC common and is grounded*.

**G** terminal is the *indoor blower input*.

**Y1** terminal is the *1st Stage cooling input*. Economizer stage when used. Balanced Climate stage when used.

**Y2** terminal is the *2nd Stage cooling input*. Compressor cooling stage when economizer or Balanced Climate is used.

**B/W1** terminal is the *gas heat*.

**A** terminal is the *ventilation option input*. This terminal energizes any factory-installed ventilation option and indoor blower.

**D** terminal is the *dehumidification input*. If installed, this terminal energizes any factory-installed dehumidification option.

**L** terminal is *24 volt alarm active output*.

### Unit Shutdown Feature (Standard on All Models)

The RT terminal is the 24VAC transformer output, and the R terminal is the 24VAC hot terminal for the operation of the equipment. RT and R are connected with a brass jumper bar which can be removed and RT and R connected to an external NC (normally closed) contact such as a fire/smoke detector that will cause shutdown of the equipment upon activation.

### Balanced Climate™ Feature (Standard on All Models)

All units are equipped with the capability of running in Balanced Climate mode. This mode is designed to enhance the comfort level by reducing the indoor airflow amount and extending the run time to help extract more humidity during cooling operation. The Y1 terminal is the 24VAC input for Balanced Climate compressor cooling operation. The Y2 terminal is the 24VAC input for compressor cooling standard operation. Y1 and Y2 are connected with a brass jumper bar which can be removed to enable Balanced Climate mode. Units with an economizer will not have the brass jumper installed. Refer to vent manuals for instructions on how Balanced Climate works with each vent.

To operate in Balanced Climate mode, a 2-stage cooling thermostat is required. The lower indoor airflow operation is overridden by utilizing a 2-stage thermostat. If the call for cooling is not satisfied within a given time frame or temperature differential (specified by the thermostat), the thermostat will send a signal to Y2 which then increases the blower speed back to the selected speed. See pages 43 – 44 for blower speed selection options.

**In units with an economizer vent installed, Balanced Climate mode should not be used. The Y1 and Y2 jumper must remain installed.**

### Dehumidification Feature (Optional)

The D terminal is the 24VAC input for dehumidification operation on dehumidification hot gas reheat equipped units. When 24VAC is applied to the D terminal, a 3-way valve solenoid is energized. The reheat coil located behind the evaporator coil is then active to reheat the supply air during cooling mode. This allows humidity to be removed from the air entering the unit without a large amount of sensible cooling capacity. During dehumidification, the indoor blower speed is reduced to help with the humidity removal. A humidity sensing thermostat or humidistat is required to control dehumidification operation. See Supplemental Instructions 7960-867 for additional information on dehumidification unit operation.

### Ventilation Features (Optional)

See ventilation instructions provided with unit for low voltage wiring.

### Low Ambient Control (LAC)

The low ambient control is a pressure switch that is attached to the liquid line of the system and monitors



high side pressure. Operation of the LAC occurs as outdoor temperatures drop below 60°F. On/Off and modulating controls are used which operate based on pressure changes caused by outdoor temperature changes. On/Off LAC operation cycles the condenser fan on/off to maintain desired liquid pressure while modulating LAC operation is factory adjusted and slows the condenser fan speed (rpm).

**Outdoor Temperature Switch and Freeze Protection Thermostat**

An outdoor temperature switch and an evaporator freeze protection thermostat is supplied with all units that have a low ambient control. The outdoor switch disables Balanced Climate mode (if enabled) when the temperature drops below 50°F. This prevents potential evaporator coil freeze up issues. The freeze thermostat cuts out compressor operation if the evaporator begins to freeze up.

**Balanced Climate Mode**

**If the application is likely to require air conditioning operation below 60°F outdoor conditions, a low ambient control (LAC) kit must be installed.**

**If the unit is being installed with any ventilation package, a Bard LAC kit must be installed.** Failure to utilize an LAC with any air conditioner can cause coil freeze up. Balanced Climate can readily be applied to duct-free (supply and return air grille) applications. It may also be applied to ducted applications with **limited rated static (total including both supply and return statics)**. Consult Bard Application Engineering for details prior to implementation.

**CAUTION:** *Balanced Climate is not a replacement for a dehumidification (hot gas reheat) unit for extreme applications, but rather an enhancement feature for limited climates and applications.*

**17. THERMOSTATS**

**TABLE 4  
CO<sub>2</sub> Controllers**

Part Number	Predominate Features
8403-056	CO <sub>2</sub> ventilation control with digital display. Normally Open SPST (Default: Close at 800ppm)
8403-096	Normally Open SPST relay closes-on-rise 24V dual wave length sensor. Default setting 950ppm, adjustable to 0-2000ppm Default off setting 1000ppm, adjustable to 0-200 ppm can be calibrated

**TABLE 5  
Thermostat Wire Size**

Transformer VA	FLA	Wire Gauge	Maximum Distance in Feet
55	2.3	20 gauge	45
		18 gauge	60
		16 gauge	100
		14 gauge	160
		12 gauge	250

**TABLE 6  
Wall Thermostats**

Thermostat	Predominant Features
8403-060 1120-445	3 Stage Cool; 3 Stage Heat Programmable/Non-Programmable Electronic HP or Conventional Auto or Manual changeover
8403-082 (VT8600U5500B)	2 stage Cool; 2 stage Heat Programmable/Non-Programmable Electronic HP or Conventional, Auto or Manual changeover with Occupancy Sensor, BACnet
8403-084 (VT8600U5000B)	2 stage Cool; 2 stage Heat Programmable/Non-Programmable Electronic HP or Conventional, Auto or Manual changeover with BACnet
8403-089 (T4 Pro)	1 stage Cool; 1 stage Heat – Heat Pump 1 stage Cool; 1 stage Heat – Conventional Programmable/Non-Programmable Electronic Auto or Manual changeover
8403-090 (T6 Pro)	2 stage Cool; 3 stage Heat – Heat Pump 2 stage Cool; 2 stage Heat – Conventional Programmable/Non-Programmable Electronic Auto or Manual changeover
8403-091 (T701-FEMA)	1 stage Cool, 1 stage Heat Non-Programmable FEMA use
8403-092 (T6 Pro Wi-Fi)	2 stage Cool, 3 stage Heat – Heat Pump 2 stage Cool, 2 stage Heat – Conventional Programmable/Non-Programmable Electronic Auto or Manual changeover Wi-Fi

**TABLE 7  
Humidity Controls**

Part Number	Predominate Features
8403-038 (H600A1014)	SPDT switching, pilot duty 50VA @ 24V; Humidity range 20-80% RH
8403-047 (H200-10-21-10)	Electronic dehumidstat SPST closes- on-rise; Humidity range 10-90% with adjustable stops

**FIGURE 11**  
**Low Voltage Wiring**  
**All Units Except Units with Economizers**

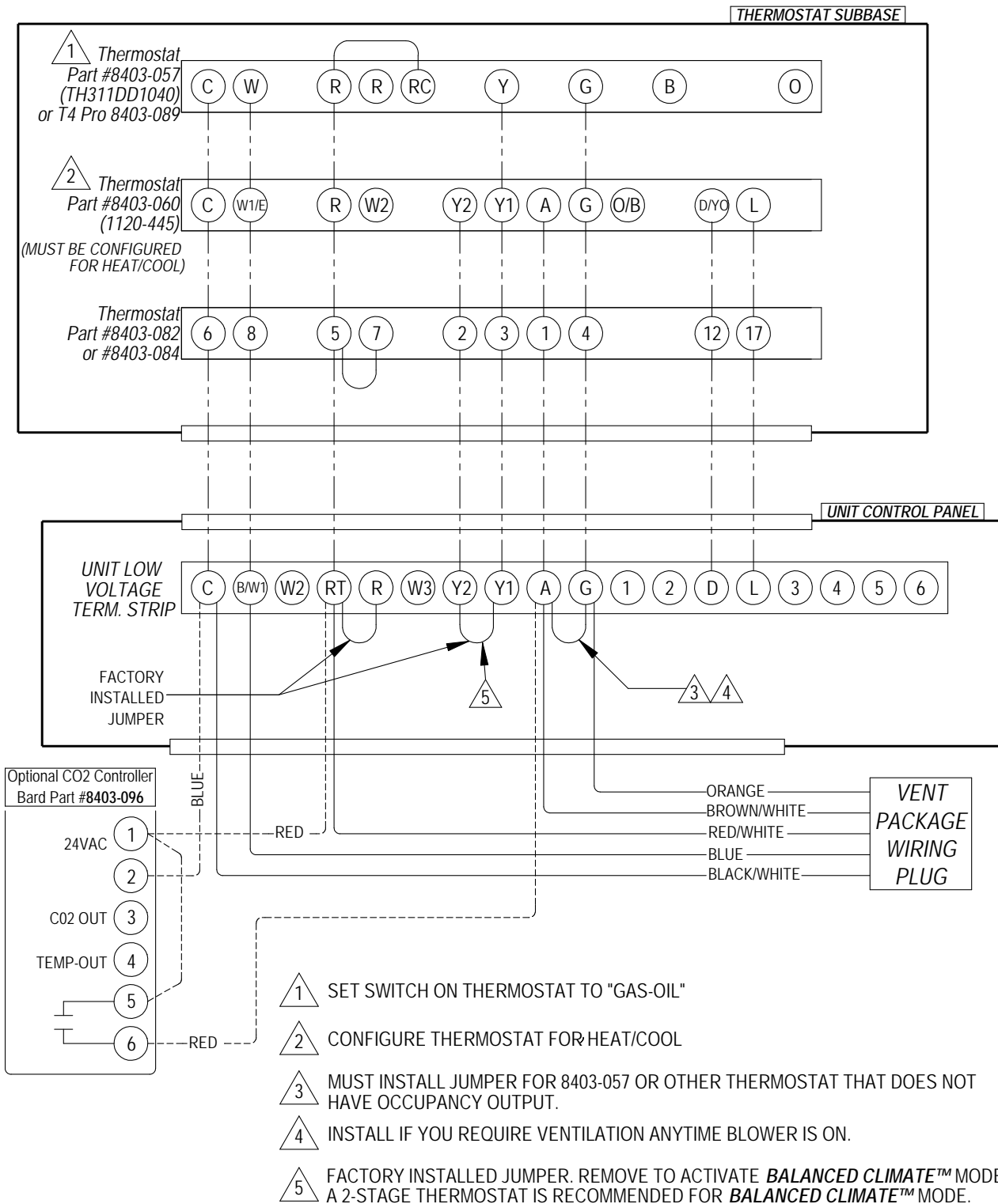

MIS-2775 I

**FIGURE 12**  
**Low Voltage Wiring**  
**Thermostat Using Separate Temperature and Humidity Controllers**

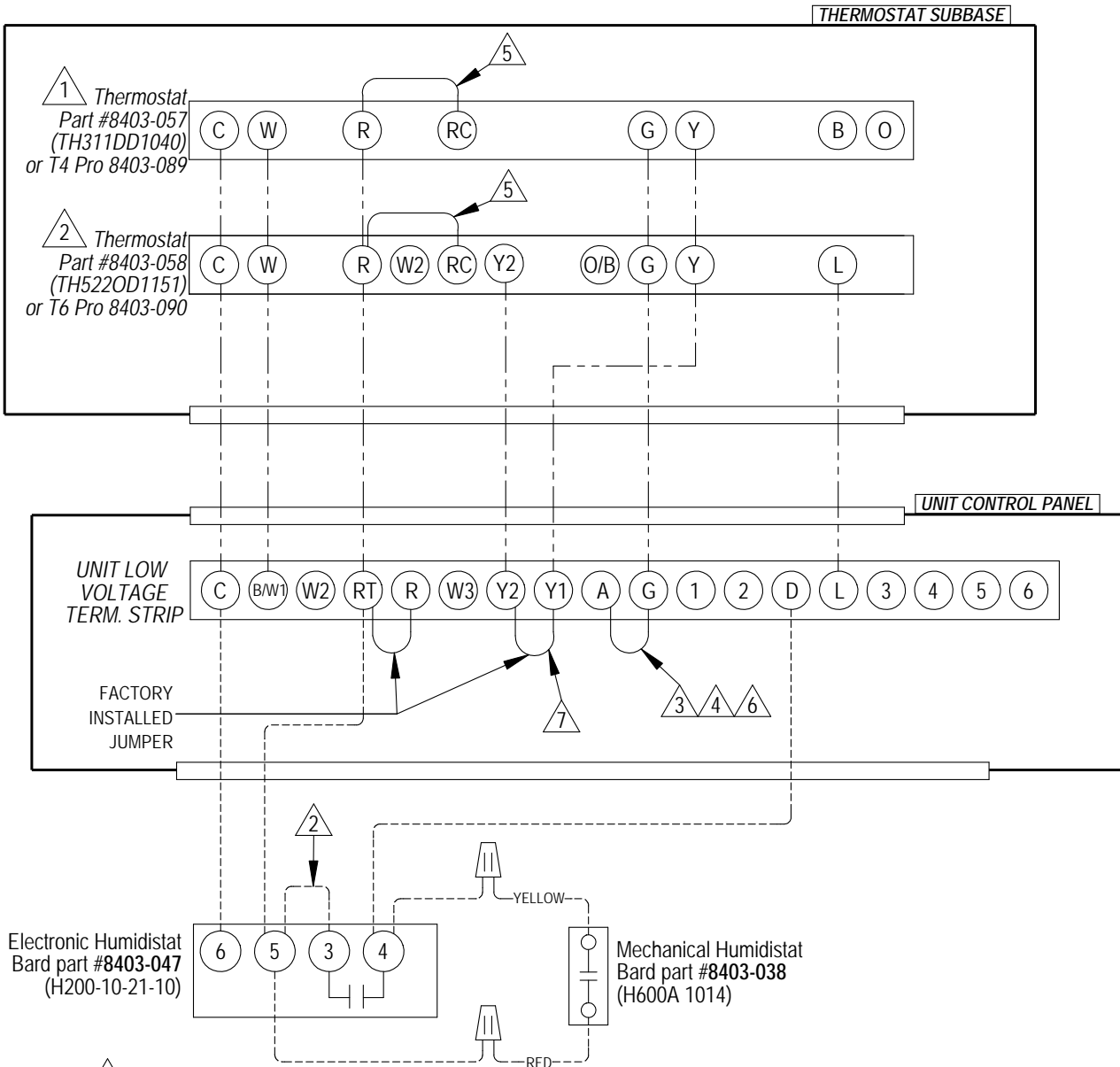

- 1 SET SWITCH ON THERMOSTAT TO "GAS-OIL"
- 2 CHANGE "SYSTEM TYPE", SET UP FUNCTION 1, FROM 5 (2 HEAT/ 1 COOL HEAT PUMP) TO 6 (2 HEAT/ 2 COOL CONVENTIONAL).
- 3 MUST INSTALL JUMPER FOR 8407-057, 8403-058 OR OTHER THERMOSTAT THAT DOES NOT HAVE OCCUPANCY OUTPUT.
- 4 INSTALL IF YOU REQUIRE VENTILATION ANYTIME BLOWER IS ON.
- 5 FACTORY INSTALLED JUMPER.
- 6 IF THIS "A" TO "G" JUMPER IS INSTALLED, YOU MUST INSURE TO REMOVE VENTILATION PACKAGE ORANGE WIRE FROM TERMINAL "G".
- 7 FACTORY INSTALLED JUMPER. REMOVE TO ACTIVATE **BALANCED CLIMATE™** MODE. A 2-STAGE THERMOSTAT IS RECOMMENDED FOR **BALANCED CLIMATE™** MODE.

MIS-2788D

**FIGURE 13**  
**Low Voltage Wiring**  
**JIFM Economizer**

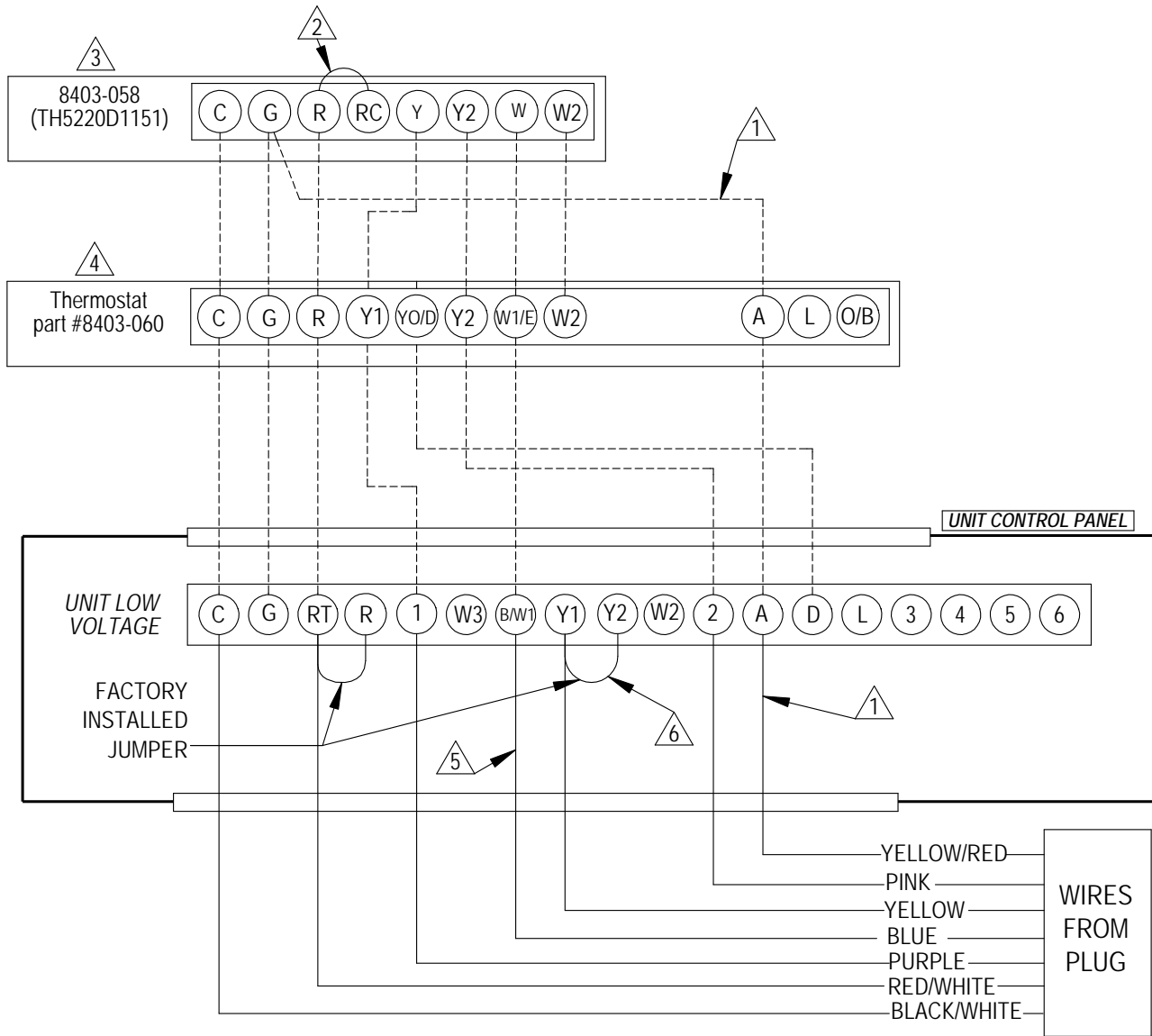

- ⚠️ *1* Must be energized to enable minimum position. NOTE: Economizer Control Default Setting is 10V (100%). Depending upon application may require setting to lower value.
- ⚠️ *2* Factory installed jumper.
- ⚠️ *3* Change "system type", set up function 1, from 5 (2 heat/ 1 cool heat pump) to 6 (2 heat/ 2 cool conventional).
- ⚠️ *4* Change model configuration from heat pump to heat/cool, and must be configured for economizer for YO/D output to be active as first stage cooling.
- ⚠️ *5* For demand ventilation and/or to disable ventilation on call for heat, move blue wire to "A" terminal.
- ⚠️ *6* Balance Climate is unavailable with economizer. Leave the jumper installed.

MIS-3349 C

**FIGURE 14**  
**Gas Pipe Connection**

UNIT	"A" LENGTH
W24G - W36G	8"
W42G - W60G	10"

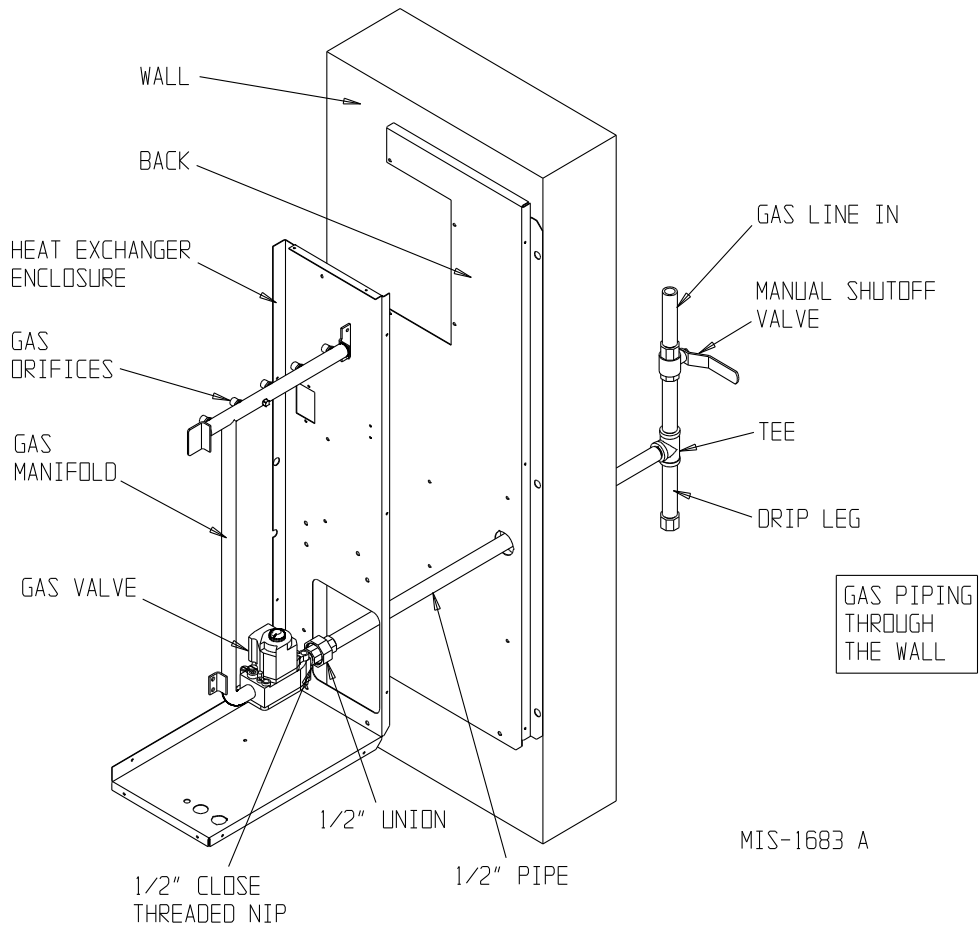
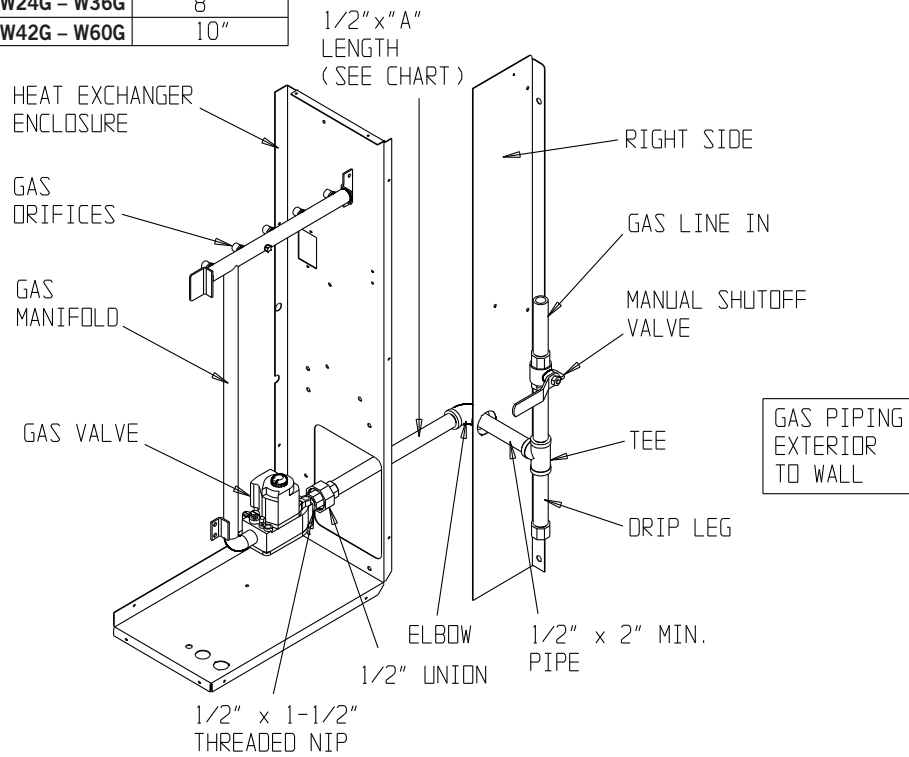

MIS-1683 A

## 18. GAS SUPPLY AND PIPING

### General Recommendations

1. Be sure the gas line complies with the local codes and ordinances, or in their absence with the National Fuel Gas Code, ANSI Z223.1, or Natural Gas Installation Code, CAN/CGA B149.1, or Propane Installation Code B149.2, latest edition.
2. A sediment trap or drip leg must be installed in the supply line to the furnace.
3. A ground joint union shall be installed in the gas line adjacent to and upstream from the gas valve and downstream from the manual shut-off valve.
4. An 1/8" NPT plugged tapping accessible for test gauge connection shall be installed immediately upstream of the gas supply connection to the furnace for the purpose of determining the supply gas pressure. This can be omitted if local codes permit use of plugged tapping in gas valve inlet.
5. Install listed manual shut-off valve in the supply gas line external to and immediately upstream of the furnace (see Figure 14).
6. Use steel or wrought iron pipe and fittings.
7. *DO NOT* thread pipe too far. Valve distortion or malfunction may result from excess pipe within the control. Use pipe joint compound resistant to the action of liquefied petroleum gases on male threads only. *DO NOT* use Teflon tape. See Table 8 and Figure 15.

**TABLE 8**  
Length of Standard Pipe Threads (Inches)

Pipe Size	Effective Length of Thread	Overall Length of Thread
3/8	1/2	9/16
3/4	1/2 – 9/16	13/16
1	9/16	1

**FIGURE 15**  
Proper Piping Practice

PROPER PIPING PRACTICE

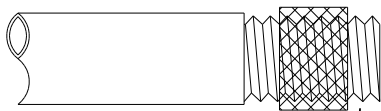

USE MODERATE AMOUNT OF THREAD SEALANT, LEAVE 2 END THREADS BARE

MIS-897

8. Refer to Table 9 for gas pipe sizes for natural gas. If more than one appliance is supplied from a single line size, capacity must equal or exceed the combined input to all appliances, and the branch lines feeding the individual appliances properly sized for each input.

**THIS PRODUCT MUST BE GAS PIPED BY A LICENSED PLUMBER OR GAS FITTER IN THE COMMONWEALTH OF MASSACHUSETTS.**

**TABLE 9**  
Gas Pipe Sizes – Natural Gas

Length of Pipe - Feet	Pipe Capacity - BTU per Hour Input Pipe Size			
	1/2"	3/4"	1"	1-1/4"
10	132,000	278,000	520,000	1,050,000
20	92,000	190,000	350,000	730,000
30	73,000	152,000	285,000	590,000
40	63,000	130,000	245,000	500,000
50	56,000	115,000	215,000	440,000
60	50,000	105,000	195,000	400,000
70	46,000	96,000	180,000	370,000
80	43,000	90,000	170,000	350,000
100	38,000	79,000	150,000	305,000

### Checking the Gas Piping

Before turning gas under pressure into piping, all openings from which gas can escape should be closed. Immediately after turning on gas, the system should be checked for leaks. This can be done by watching the 1/2 cubic foot test dial, allowing 4 minutes to show any movement, soaping each pipe connection and watching for bubbles. If a leak is found, make the necessary repairs immediately and repeat the above test. The furnace must be isolated from the gas supply piping system by closing the manual shut-off valve on the combination gas control valve during pressure testing of the gas supply piping system at pressures up to 1/2 PSIG. The furnace and its individual shut-off valve must be disconnected from supply piping and supply piping capped during any pressure testing of supply piping system at test pressures in excess of 1/2 PSIG.

Defective pipes or fittings should be replaced and not repaired. Never use a flame or fire in any form to locate gas leaks; use a soap solution.

After the piping and meter have been checked completely, purge the system of air. *DO NOT* bleed air inside the furnace. **Be sure to check and relight all the gas pilots on other appliances that may have been extinguished because of interrupted gas supply.**

## **PROPANE (LP) GAS CONVERSION**

*This unit may be converted in the field for use with propane (LP) gas. Propane gas conversion kit number WGCK-1 is designed for conversions of units installed from 0 – 6,000' elevations. Propane gas conversion kit number WGCK-2 is designed for conversions of units installed from 6,001' – 10,000' elevations. These kits may be purchased from the local distributor.*

## **WARNING**

When converting from propane (LP) gas to natural gas, the gas orifice spuds and gas valve spring must be replaced and the gas valve regulator pressure must be adjusted correctly. Failure to do so can result in fire, injury or death. Refer to Tables 11A and 11B for proper orifice sizing.

Natural gas spring kit, part number 5603-007, can be purchased through the local distributor.

## **19. MANIFOLD PRESSURE ADJUSTMENT**

A 0 to 15" water manometer with 0.1" resolution and a 1/8" NPT manual shut-off valve is needed to measure actual manifold pressure.

## **WARNING**

Correct manifold pressure is necessary for proper ignition and burner operation. Failure to accurately adjust pressure could cause heat exchanger failure.

1. Turn off gas at equipment shut-off valve in gas supply line just ahead of furnace.
2. Remove plug from outlet pressure tap in gas control or gas manifold.
3. Install 1/8" NPT manual shut-off valve in hole vacated by plug. Make sure shut-off valve is in OFF position.
4. Attach manometer to 1/8" NPT manual shut-off valve just installed.

5. Slowly open equipment shut-off valve in gas supply line just ahead of furnace. Start furnace following "Operating Instructions" on front door.
6. Slowly open 1/8" NPT manual shut-off valve leading to manometer.
7. Read manifold pressure on manometer.
8. Adjust manifold pressure by turning gas control regulator adjusting screw clockwise to increase pressure or turning counterclockwise to decrease pressure. Manifold pressure must be within allowable range as follows:
  - Natural gas manifold pressure must be between 3.2" and 3.8" W.C. Rated pressure is 3.5" W.C.
  - Propane gas (LP) manifold pressure must be between 9.7" and 10.3" W.C. Rated pressure is 10" W.C.

*NOTE: For natural gas, if gas flow rate can't be properly set within these pressure ranges, the main burner orifices must be changed to obtain proper gas flow rate.*

9. Shut off furnace. Turn off gas at equipment shut-off valve in gas supply line just ahead of furnace. Install outlet pressure tap plug in gas control. Turn on gas.
10. Check regulator adjustment cover screw and gas control plug for gas leaks. Use a commercial soap solution made for leak detection.

## **20. CHECKING GAS INPUT RATE**

It is the installer's responsibility to see that the BTU input rate of the furnace is properly adjusted. Under-firing could cause inadequate heat, excessive condensation or ignition problems. Overfiring could cause sooting, flame impingement or overheating of heat exchanger.

## **WARNING**

Failure to adjust furnace to the proper firing rate could cause heat exchanger failure.

Depending on local gas heating value and elevation, the manifold pressure may need to be adjusted or the orifices changed to get proper gas input rate. Check with the local gas supplier to determine heating value (BTU/cu. ft.) of natural gas in the area.

*NOTE: If furnace is being installed at an altitude of more than 6,000' above sea level, you must derate the furnace. See Section 21 "Standard Orifice Sizing and High Altitude Derate".*



## Natural Gas Input Rate

Natural gas heating value (BTU/cu. ft.) can vary significantly. Before starting natural gas input check, obtain gas heating value at the location from local supplier. A stopwatch will be needed to measure actual gas input.

1. Gas supply pressure must be between 5" and 7" W.C. for natural gas.
2. Turn off all other gas appliances. The pilots may be left on.
3. Start furnace following "Operating Instructions" on front door.
4. Let furnace warm up for 6 minutes.
5. Locate gas meter. Determine which dial has the least cubic feet of gas and how many cubic feet per revolution it represents. This is usually one-half, one or two cubic feet per revolution.
6. With stopwatch, measure time it takes to consume two cubic feet of gas.
  - If dial is one-half cubic foot per revolution, measure time for four revolutions.
  - If dial is one cubic foot per revolution, measure time for two revolutions.
  - If dial is two cubic feet per revolution, measure time for one revolution.
7. Divide this time by two. This gives average time for one cubic foot of gas to flow through meter. Example: If it took 58 seconds for two cubic feet to flow, it would take 29 seconds for one cubic foot to flow.
8. Calculate gas input using this formula:

$$\text{Gas input} = \frac{\text{Gas Heating Value (BTU/cu. ft.)} \times 3,600 \text{ sec/hr}}{\text{Time (Seconds for one cubic foot of gas)}} = \text{BTU/hour}$$

Example:

Assume it took 29 seconds for one cubic foot of gas to flow and heating value of 1,000 BTU/cu. ft.

$$\text{Gas input} = \frac{1,000 \times 3,600}{29} = 124,138 \text{ BTU}$$

If no other pilots were left on, this is the furnace gas input.

9. If the water heater, dryer or range pilots were left on, allow for them in calculating correct furnace gas input. A quick way is to allow 1,000 BTU per hour for a water heater, 500 BTU per hour for dryer and 500 BTU per hour for each range burner pilot.

Example:

If the gas water heater, dryer, two range burner pilots and one oven pilot were left on, allow:

Water heater pilot	1,000 BTU per hour
Dryer pilot	500 BTU per hour
2 range burner pilots	1,000 BTU per hour
1 range oven pilot	500 BTU per hour
	<hr/>
	3,000 BTU per hour

Subtracting 3,000 BTU per hour from 124,138 BTU per hour measured above equals 121,138 BTU per hour. This would be the correct furnace gas input after allowing for pilots left on.

10. Manifold pressure may be adjusted within the range of 3.2" W.C. to 3.8" W.C. to get rated input  $\pm 2$  percent. See Section 19, "Manifold Pressure Adjustment." If rated input with manifold pressure cannot be gotten within the allowable range, orifices must be changed.

## Propane (LP) Gas Input Rate

### **WARNING**

Propane (LP) gas installations do not have gas meters to double check input rate. Measure manifold pressure adjustment with an accurate manometer. Failure to accurately adjust pressure could cause heat exchanger failure, asphyxiation, fire or explosion, resulting in damage, injury or death.

1. Make the main burner orifices are correct.
2. Gas supply pressure must be between 11" and 13" W.C. for propane (LP) gas.
3. Start furnace following "Operating Instructions" on front door.
4. Let furnace warm up for 6 minutes.
5. Adjust manifold pressure to 10.0" W.C.  $\pm 0.3$ ". See Section 19, "Manifold Pressure Adjustment".

### **WARNING**

Do not set propane (LP) manifold pressure at 11.0" W.C. It could cause heat exchanger failure.



## 21. STANDARD ORIFICE SIZING AND HIGH ALTITUDE DERATE

This furnace is shipped with fixed gas orifices for use with natural gas and sized for 1000 BTU/cubic foot gas. Make sure actual gas input does not exceed rating plate input. The orifices may need to be changed to get the correct gas input. Whether they need to be changed or not depends on input and the gas heat value at standard conditions and elevation. Consult the local gas supplier for gas heat value and any special derating requirements. See Section 20 for more information.

At higher altitudes, the density of the air is reduced. Therefore, for proper combustion, the quantity of gas burned in the furnace must also be reduced. This is called derating. This unit must be derated when installed at altitudes greater than 6,000' above sea level. A high altitude pressure switch must also be installed for operation above 6,000'. High Altitude Pressure Switch Kit number 8620-189 is designed for this application.

It is the installer's responsibility to see that the furnace input rate is adjusted properly. Derating must be achieved by reducing the size of the main burner orifices. Derating the furnace by adjusting the manifold pressure lower than the range specified in the Section 19, "Manifold Pressure Adjustment" is considered to be an improper procedure.

Above 6,000' elevation orifice changes are required, and capacity reductions are a function of altitude impact and orifice change. Pressure switch change is required above 6,000' elevation. For natural gas, see Altitude Table 10 below and Orifice Tables 11A and 11B on following pages.

**TABLE 10**  
**Natural Gas Derate Capacities**  
**for All Models**

W**G Rated Input	Sea Level	1000	2000	3000	4000	5000	6000	7000	8000	9000	10,000
41,000	40,500	39,204	37,908	36,612	35,640	34,992	34,182	33,696	33,048	32,643	32,076
45,000	45,000	43,560	42,120	40,680	39,600	38,880	37,980	37,440	36,720	36,270	35,640
61,000	60,750	58,806	56,862	54,918	53,460	52,488	51,273	50,544	49,572	48,965	48,114
68,000	67,500	65,340	63,180	61,020	59,400	58,320	56,970	56,160	55,080	54,405	53,460
75,000	75,000	72,600	70,200	67,800	66,000	64,800	63,300	62,400	61,200	60,450	59,400
81,000	81,000	78,408	75,816	73,224	71,280	69,984	68,364	67,392	66,096	65,286	64,152
90,000	90,000	87,120	84,240	81,360	79,200	77,760	75,960	74,880	73,440	72,540	71,280
100,000	100,000	96,800	93,600	90,400	88,000	86,400	84,400	83,200	81,600	80,600	79,200
113,000	112,500	108,900	105,300	101,700	99,000	97,200	94,950	93,600	91,800	90,675	89,100
125,000	125,000	121,000	117,000	113,000	110,000	108,000	105,500	104,000	102,000	100,750	99,000

**TABLE 11A**  
**Natural Gas Orifice Tables for Models W24G, W30G and W36G**

Factory Standard Input	Gas Heat* Value BTU/Cu. Ft.	Up to 6,000' No Changes Except for BTU Content	6,001' to 8,000' Requires Pressure Switch Change and Orifice Change Based on BTU Content	8,001' to 10,000' Requires Pressure Switch Change and Orifice Change Based on BTU Content
25000 BTU Per Burner	700-749	2.75	2.70	2.60
	750-799	2.70	2.60	2.50
	800-849	2.60	2.50	2.45
	850-899	2.50	2.45	2.35
	900-949	2.45	2.35	<b>(2.30)</b>
	950-999	2.35	<b>(2.30)</b>	2.25
	1000-1049**	<b>(2.30)</b>	2.25	<b>[2.20]</b>
	1050-1100	2.25	<b>[2.20]</b>	2.15
	Pressure Switch	Standard (.55)	Order 8620-189 High Altitude Pressure Switch Kit (.42)	
<b>(2.30)</b> is the standard factory-installed orifice size			<b>[2.20]</b> orifices are shipped with the unit for field-installed optional 10% derate	

Optional 10% Field-Converted Derate	Gas Heat* Value BTU/Cu. Ft.	Up to 6,000' No Changes Except for BTU Content	6,001' to 8,000' Requires Pressure Switch Change and Orifice Change Based on BTU Content	8,001' to 10,000' Requires Pressure Switch Change and Orifice Change Based on BTU Content
22250 BTU Per Burner	700-749	2.60	2.50	2.45
	750-799	2.50	2.45	2.40
	800-849	2.45	2.40	<b>(2.30)</b>
	850-899	2.40	<b>(2.30)</b>	2.25
	900-949	<b>(2.30)</b>	2.25	<b>[2.20]</b>
	950-999	2.25	<b>[2.20]</b>	2.15
	1000-1049**	<b>[2.20]</b>	2.15	2.10
	1050-1100	2.15	2.15	2.10
	Pressure Switch	Standard (.55)	Order 8620-189 High Altitude Pressure Switch Kit (.42)	
<b>[2.20]</b> orifices are shipped with the unit for field-installed optional 10% input rate			<b>(2.30)</b> is the factory-installed orifice size for full rated input	

\* At standard conditions: 30.00 inches Mercury, 60F, saturated, .60 specific gravity.

\*\* All Natural Gas factory orifice sizing and standard input ratings based on nominal 1025 BTU/cu. ft. gas and sea level conditions

All other orifice sizes shown are available as individual field-supplied items. See orifice tables below for specifications and number required.

Orifice Size (mm)	Orifice Diameter
2.10	0.0826
2.15	0.0846
2.20	0.0866
2.25	0.0885
2.30	0.0905
2.35	0.0925
2.40	0.0945

Orifice Size (mm)	Orifice Diameter
2.45	0.0964
2.50	0.0984
2.60	0.1024
2.70	0.1063
2.75	0.1082
2.80	0.1102
2.90	0.1142

No. of Orifices Required Based on Unit Input Rating
41,000 (2)
45,000 (2)
61,000 (3)
68,000 (3)
75,000 (3)
81,000 (4)
90,000 (4)
100,000 (4)
113,000 (5)
125,000 (5)

**TABLE 11B**  
**Natural Gas Orifice Tables for Models W42G, W48G and W60G**

<b>Factory Standard Input</b>	<b>Gas Heat* Value BTU/Cu. Ft.</b>	<b>Up to 6,000' No Changes Except for BTU Content</b>	<b>6,001' to 8,000' Requires Pressure Switch Change and Orifice Change Based on BTU Content</b>	<b>8,001' to 10,000' Requires Pressure Switch Change and Orifice Change Based on BTU Content</b>
<b>25000 BTU Per Burner</b>	700-749	2.90	2.80	2.70
	750-799	2.80	2.70	2.60
	800-849	2.70	2.60	2.50
	850-899	2.60	2.50	2.45
	900-949	2.50	2.45	<b>(2.40)</b>
	950-999	2.45	<b>(2.40)</b>	2.35
	1000-1049**	<b>(2.40)</b>	2.35	<b>[2.30]</b>
	1050-1100	<b>[2.30]</b>	2.25	2.20
	Pressure Switch	Standard (.55)	Order 8620-189 High Altitude Pressure Switch Kit (.42)	
<b>(2.40) is the standard factory-installed orifice size</b>			<b>[2.30] orifices are shipped with the unit for field-installed optional 10% derate</b>	
<b>Optional 10% Field Converted Derate</b>	<b>Gas Heat* Value BTU/Cu. Ft.</b>	<b>Up to 6,000' No Changes Except for BTU Content</b>	<b>6,001' to 8,000' Requires Pressure Switch Change and Orifice Change Based on BTU Content</b>	<b>8,001' to 10,000' Requires Pressure Switch Change and Orifice Change Based on BTU Content</b>
<b>22250 BTU Per Burner</b>	700-749	2.75	2.70	2.60
	750-799	2.70	2.60	2.50
	800-849	2.60	2.50	
	850-899	2.50	2.45	<b>(2.40)</b>
	900-949	<b>(2.40)</b>	2.35	<b>[2.30]</b>
	950-999	2.35	<b>[2.30]</b>	2.25
	1000-1049**	<b>[2.30]</b>	2.25	2.20
	1050-1100	2.25	2.25	2.20
	Pressure Switch	Standard (.55)	Order 8620-189 High Altitude Pressure Switch Kit (.42)	
<b>[2.30] orifices are shipped with the unit for field-installed optional 10% input rate</b>			<b>(2.40) is the factory-installed orifice size for full rated input</b>	

\* At standard conditions: 30.00 inches Mercury, 60F, saturated, .60 specific gravity.

\*\* All Natural Gas factory orifice sizing and standard input ratings based on nominal 1025 BTU/cu. ft. gas and sea level conditions

All other orifice sizes shown are available as individual items. See orifice tables on page 32 for part numbers and number required.

## 22. CONVERSION OF GAS INPUT BTUH FROM HIGH TO LOW RATING

All the derated WG series units are produced with maximum BTUH input orifices installed. To field convert input, a change to main burner orifices is required.

*NOTE: No change to air orifices is necessary. A set of low input orifices is shipped with every unit. They will be found packaged in a bag behind the burner door. Refer to the unit rating plate to confirm the proper orifice size. Proper installation of the orifices is detailed as follows:*

1. Shut off electrical supply to the unit.
2. Shut off gas supply to the unit.
3. Remove burner access panel.
4. Disconnect gas valve from gas supply piping.
5. Disconnect the two wires from the gas valve.
6. Remove the manifold assembly so that orifices are now accessible and remove orifices.
7. Apply a modest amount of pipe compound to the new orifices and screw them into the manifold.
8. To assemble burner, reverse Steps 1 through 7.

### **WARNING**

Failure to follow these instructions could create a hazard resulting in property damage, bodily injury, or death.

## 23. MEASURING AIR TEMPERATURE RISE

Air temperature rise (supply air temperature minus return air temperature) must be within allowable air temperature rise range specified on furnace rating plate.

Two thermometers with 1° resolution capable of reading up to 200° F will be needed. Check thermometers to make sure they agree, or compensate accordingly.

Follow this procedure:

1. Open supply air registers and return air grilles. Make sure the registers and grilles are free of obstruction from rugs, carpets, drapes or furniture.
2. Set balancing dampers in supply duct system.
3. Check duct work for obstructions or leaks.

4. Make sure filters are clean and in place.
5. Place one thermometer in supply air plenum approximately 2' from furnace. Locate thermometer tip in center of plenum to ensure proper temperature measurement.
6. Place second thermometer in return air duct approximately 2' from furnace. Locate thermometer tip in center of duct to ensure proper temperature measurement.
7. Set room thermostat on highest temperature setting. Operate furnace 10 minutes. Record supply air and return air temperatures.
8. Calculate air temperature rise by subtracting return air temperature from supply air temperature.
  - If air temperature rise is above the temperature rise range on rating plate, furnace is overfired or has insufficient airflow. Check gas input following the instructions in Section 20, "Checking Gas Input Rate". If air temperature rise is still above temperature rise range specified, more heating airflow is needed. Check duct work and grilles to make sure all are properly sized.
  - If air temperature rise is below the temperature rise range on rating plate, furnace is underfired or has too much airflow. Check gas input following the instructions in Section 20, "Checking Gas Input Rate". If air temperature rise is still below temperature rise range specified, less heating airflow is needed. Adjust dampers or grilles as needed.
  - After making adjustments, check air temperature rise to verify that resulting air temperature rise is within allowable range. If air temperature rise is still outside the temperature rise range specified on rating plate, check duct system design with a qualified heating engineer. It may be necessary to re-size the duct work. Recheck air temperature rise after revising duct systems.

9. Set room thermostat to desired setting.
10. Remove thermometers and seal duct work holes.

**NOTE:** Failure to seal holes could result in reduced system performance.

## 24. FILTERS

A 2" thick throwaway filter is supplied with each unit. This filter is installed by opening the filter service door (see Figure 16).

Replacement filters are available through the dealer.

**FIGURE 16**  
**Access Internal Filter Through Upper Service Door**

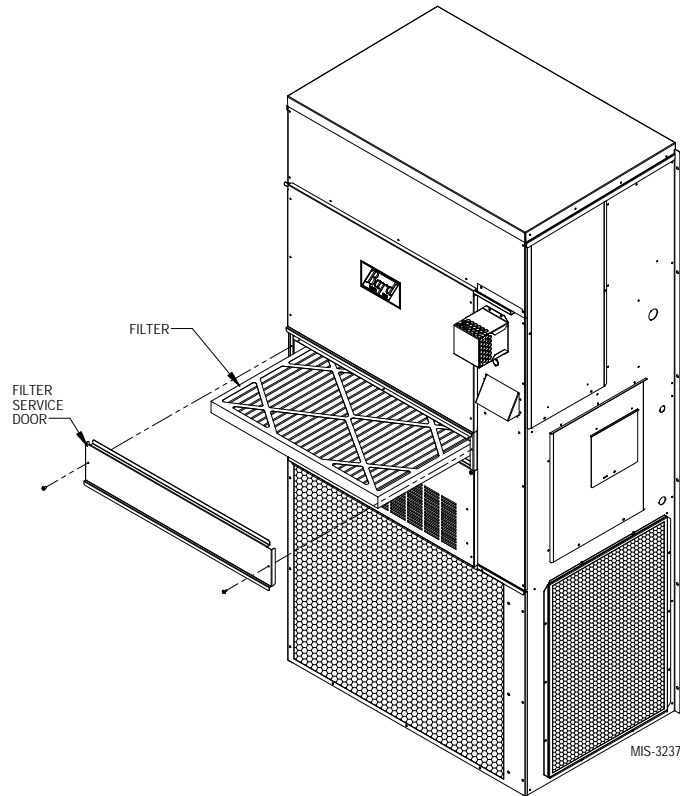

## 25. COMPRESSOR CONTROL MODULE

The compressor control module is standard on models covered by this manual.

### Features

- Delay-on-Make Timer
- Short Cycle Protection/Delay-on-Break
- High Pressure Detection
- HPC Status LED
- Test Mode
- Brownout Protection with Adjustment

### Delay-on-Make Timer

A delay-on-make timer is included to be able to delay startup of the compressor. This is desired when more than one unit is on a structure so that all of the units do not start at the same time which could happen after a power loss or building shutdown. The delay-on-make time period is 2 minutes plus 10% of the delay-on-break time period. To ensure that all of the units do not start at the same time, adjust the delay-on-break timer on each unit to a slightly different delay time.

### Short Cycle Protection/Delay-on-Break

An anti-short cycle timer is included to prevent short cycling the compressor. This is adjustable from 30 seconds to 5 minutes via the adjustment knob. Once

a compressor call is lost, the time period must expire before a new call will be initiated.

### High Pressure Detection

High pressure switch monitoring allows for a lockout condition in a situation where the switch is open. If the high pressure switch opens, the CCM will de-energize the compressor. If the switch closes again, it will then restart the compressor after the delay-on-break setting has expired on the device. If the switch trips again during the same thermostat call, the compressor will be de-energized and the alarm terminal will be energized indicating an alarm. The red LED will light and stay on until power is cycled to the control or a loss of voltage is present at Y terminal for more than ½ second.

### Test Mode

By rapidly rotating the potentiometer (POT) clockwise (see Figure 17 on page 36), all timing functions will be removed for testing.

The conditions needed for the unit to enter test mode are as follows: POT must start at a time less than or equal to the 40 second mark. The POT must then be rapidly rotated to a position greater than or equal to the 280 second mark in less than ¼ second. Normal operation will resume after power is reset or after the unit has been in test mode for at least 5 minutes.

### Brownout Protection with Adjustment

Brownout protection may be necessary if the utility power or generator power has inadequate power to prevent the voltage from dropping when the compressor starts. This is rare but can happen if the generator is undersized at the site or if the site is in a remote location far from the main power grid. Under normal circumstances, allowing the brownout to be ignored for a time period should not be needed. The 8201-169 is shipped in “O” do not ignore position, with all the DIP switches off (see Figure 17).

If ignoring the brownout is needed because of the above conditions, three preset timers can be set by DIP switches in order to delay signaling a power brownout for a specific length of time after compressor contactor is energized. This allows the compressor a time period to start even if the voltage has dropped and allows the voltage to recover. This delay only happens when the CC terminal energizes. The delay can be set to 1 second (A DIP switch), 5 seconds (B DIP switch) or 10 seconds (C DIP switch); time is not cumulative—only the longest setting will apply. If the voltage recovers during the brownout delay period, the compressor will start.

If a brownout condition is detected by the 8201-169, the troubleshooting light will flash blue. The light will continue to flash until the cooling call is satisfied or power is removed from the Y terminal. This condition does not prevent operation, it only indicates that a brownout condition was present at some point during the cooling call. If a brownout condition is detected, CC will be de-energized and will retry after the delay-on-make timer is satisfied; this process will continue until call is satisfied.

If user chooses the “O” do not ignore position when the site has inadequate utility or generator power, this could lead to the compressor never starting. The control will see the brownout immediately and not start.

A common scenario and one that has been seen in the field is when a unit or units switches from utility power to generator power. With slower transfer switches, the time delay between the utility power and generator power didn't cause a problem. The units lost power, shut off and came back on line normally. With the introduction of almost instantaneous transfer switches, the millisecond long power glitch can be enough that the compressor will start to run backwards. In this scenario, the CCM will catch this and restart the units normally.

**FIGURE 17**  
**8201-169 COMPRESSOR CONTROL MODULE**

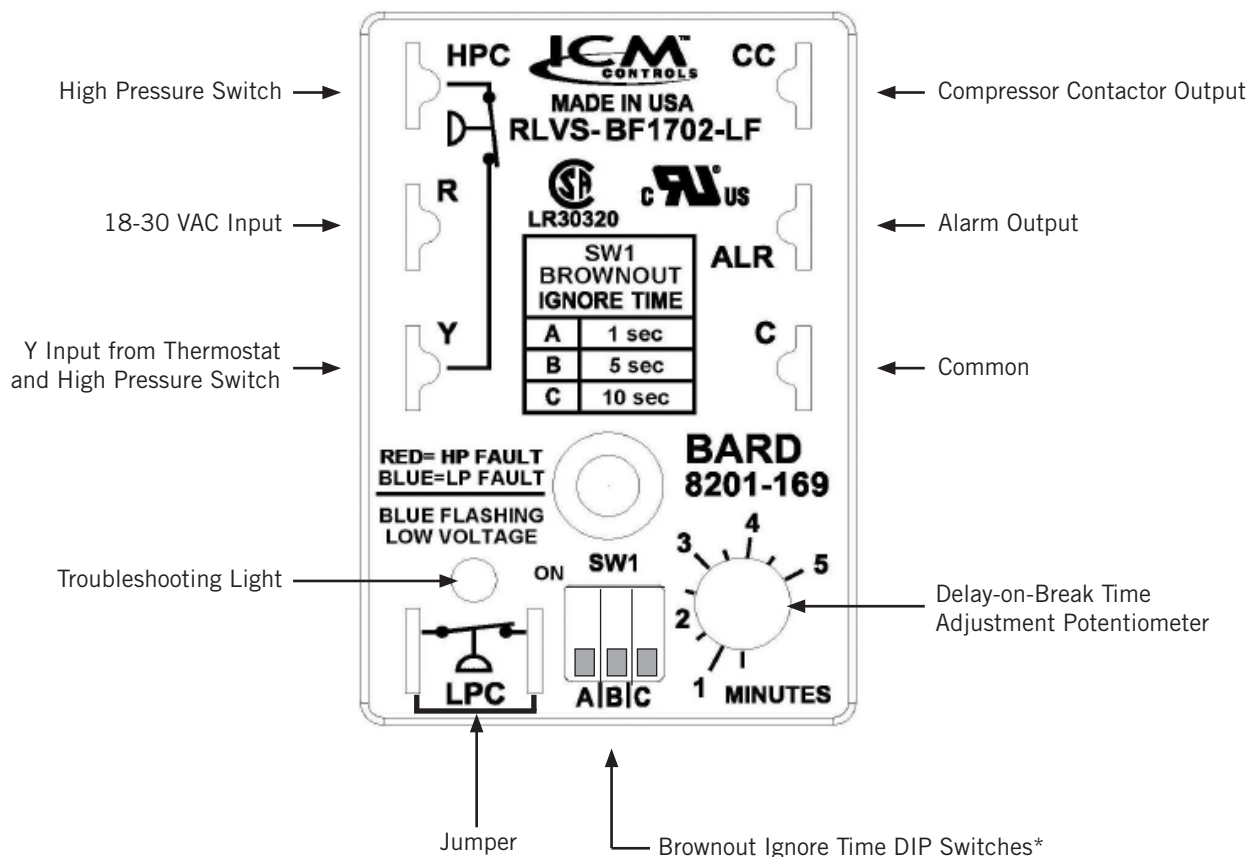

\* Turn on only one switch for that specific ignore time setting. 10 seconds is the maximum brownout ignore time.



## 26. PHASE MONITOR

All units with three phase scroll compressors are equipped with a three phase line monitor to prevent compressor damage due to phase reversal.

The phase monitor in this unit is equipped with two LEDs. If the "Y" signal is present at the phase monitor and phases are correct, the green LED will light.

If phases are reversed, the red fault LED will be lit and compressor operation is inhibited.

If a fault condition occurs, reverse two of the supply leads to the unit. Do not reverse any of the unit factory wires as damage may occur.

## 27. LIGHTING AND SHUTDOWN INSTRUCTIONS

FIGURE 18  
Lighting and Shutdown Instruction Label

### FOR YOUR SAFETY READ BEFORE OPERATING

**WARNING:** If you do not follow these instructions exactly, a fire or explosion may result causing property damage, personal injury or loss of life.

- A. This appliance does not have a pilot. It is equipped with an ignition device which automatically lights the burner. Do NOT try to light the burner by hand.
- B. BEFORE OPERATING smell all around the appliance area for gas. Be sure to smell next to the floor because some gas is heavier than air and will settle on the floor.  
WHAT TO DO IF YOU SMELL GAS
  - \* Do not try to light any appliance.
  - \* Do not touch any electric switch; do not use any phone in your building.
  - \* Immediately call your supplier from a neighbor's phone. Follow the gas supplier's instructions.
- \* If you cannot reach your gas supplier; call the fire department.
- C. Use only your hand to push in or move the gas control lever. Never use tools. If the lever will not push in or turn by hand, don't try to repair it, call a qualified service technician. Force or attempted repair may result in a fire or explosion.
- D. Do not use this appliance if any part has been under water. Immediately call a qualified service technician to inspect the appliance and to replace any part of the control system and any gas control which has been under water.

### OPERATING INSTRUCTIONS

1. STOP! Read the safety information above on this label.
2. Set the thermostat to lowest setting
3. Turn off all electric power to the appliance.
4. This appliance is equipped with an ignition device which automatically lights the burner. Do NOT try to light the burner by hand.
5. Remove control access panel.
6. Push in gas control knob slightly and turn clockwise to "OFF".  
NOTE: Knob cannot be turned to "OFF" unless knob is pushed in slightly. Do not force.
7. Wait five (5) minutes to clear out any gas. Then smell for gas, including near the floor. If you smell gas, STOP! Follow "B" in the safety information above on this label. If you don't smell gas, go to the next step.
8. Turn gas control knob counterclockwise to "ON".
9. Replace control access panel.
10. Turn on all electric power to the appliance.
11. Set thermostat to desired setting.
12. If the appliance will not operate, follow the instructions "To Turn Off Gas To Appliance" and call your service technician or gas supplier.

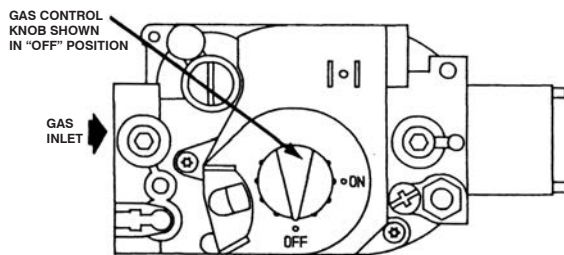

### TO TURN OFF GAS TO APPLIANCE

1. Set the thermostat to lowest setting.
2. Turn off all electric power to the appliance if service is to be performed.
3. Remove control access panel.
4. Push in gas control lever slightly and move to "OFF". Do not force.
5. Replace control access panel.

7961-509

## 28. SERVICE AGENCY PROCEDURES

### CAUTION

Label all wires prior to disconnection when servicing controls. Wiring errors can cause improper and dangerous operation. Verify proper operation after servicing.

### WARNING

Follow these procedures before inspecting furnace.

- Turn room thermostat to its lowest or off setting.
- Turn off manual gas shut-off valve.
- Wait at least 5 minutes for furnace to cool if it was recently operating.
- Turn off furnace electrical power; failure to do so could result in injury or death.

#### Main Burner

Observe the main burners in operation. The flame should be mostly “blue” with possibly a little orange (not yellow) at the tips of the flame. The flames should be in the center of the heat exchanger tubes and not impinging on the heat exchanger surfaces themselves.

Observe the fire until the blower starts (there is a normal delay period until the heat exchanger warms up). There should be no change in the size or shape of the flame. If there is any wavering or blowing of the flame on blower start-up, it is an indication of a possible leak in the heat exchanger.

**FIGURE 19**  
**Top View of Gas Control**

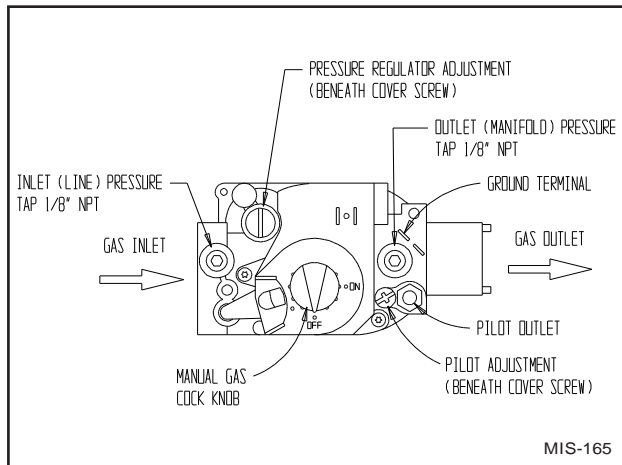

#### Burners/Heat Exchanger/Flue Gas Passage Ways

The burners, heat exchanger and interior flue gas passages may be inspected using a light on small mirror or an extension handle. Remove the screws securing the inducer and collector box. Now inspect the upper tubes of the heat exchanger.

Check the exterior of the heat exchanger and the interior flue gas passages for any evidence of deterioration due to corrosion, cracking or other causes. If signs of sooting exist, remove the burners and clean the heat exchanger, as required.

## 29. MAINTAINING UNIT IN GOOD WORKING ORDER

The unit should be inspected annually by a qualified service agency.

### WARNING

Use replacement parts listed in the Replacement Parts list only. The use of incorrect parts could cause improper unit operation, resulting in damage, injury or death.



# **WARNING**

Disconnect electrical power before servicing unit. Failure to do so could result in electrical shock or death.

## Annual Maintenance

Routine inspection and maintenance procedures are the responsibility of the user and are outlined below.

1. Before inspecting unit:
  - A. Turn room thermostat to lowest or off setting.
  - B. Turn off equipment gas shut-off valve.
  - C. Wait for unit to cool if it was recently operating.
  - D. Turn off electrical power to unit.
2. Inspect the following:
  - A. Vent terminal and combustion air intake terminal. Make sure both are free from obstructions.
  - B. Vertical vent applications – Inspect venting system. Make sure system has no holes, is physically sound and free from obstructions.
  - C. Make sure the supply and return air flange sleeves or duct work are securely fastened to unit and physically sound.
  - D. Supply and return grilles must be open and free from obstructions.
  - E. Inspect to make sure the unit is securely fastened to the wall. Seal any possible leaks between unit and wall with appropriate exterior sealing material.
  - F. Inspect burners, heat exchanger, induced draft blower and induced draft blower collector box. There must be no obvious signs of deterioration.
  - G. Inspect all electrical connections and wiring.
  - H. Check all gas piping for leaks with soap solution used to detect leaks.
  - I. Inspect, clean and repair as needed the entire blower assembly, air filters, draft inducer, cooling coils and vent options (if installed).

## Routine Maintenance

1. Air Filters – Check the condition at least monthly when the unit is in use, and replace as necessary.
2. Lubrication Requirements – The indoor circulating air blower motor and outdoor circulating air fan motor are permanently lubricated and requires no re-oiling. The combustion air blower motor requires no re-oiling.

# **WARNING**

Turn off electrical power supply to prevent injury from moving parts or electric shock.

## Routine Inspection

1. Inspect the physical support of the unit annually to make sure it is securely fastened to the building. Also look for any obvious signs of deterioration.
2. Inspect the main burners at the beginning of each heating season and clean as necessary.
3. Inspect the vent terminal and combustion air intake hood for any obvious deterioration, to make sure it is free and clear of any obstructions.

## 30. TROUBLESHOOTING NIDEC SELECTECH SERIES ECM MOTORS

### If the Motor Is Running

1. It is normal for the motor to rock back and forth on start up. Do not replace the motor if this is the only problem identified.
2. If the system is excessively noisy, does not appear to change speeds in response to a demand (Heat, Cool, Other) or is having symptoms during the cycle such as tripping limit or freezing coil, check the following:
  - A. Wait for programmed delays to time out.
  - B. Ensure that the motors control inputs are wired as shown in the factory-supplied wiring diagram to ensure motor is getting proper control signals and sequencing.
  - C. Remove the filter and check that all dampers, registers and grilles are open and free flowing. If removing the filters corrects the problem, clean or replace with a less restrictive filter. Also check and clean the blower wheel or coil as necessary.

- D. Check the external static pressure (total of both supply and return) to ensure it is within the range as listed on the unit serial plate. If higher than allowed, additional duct work is needed.
- E. If the motor does not shut off at the end of the cycle, wait for any programmed delays to time out (no more than 90 seconds). Also make sure that there is no call for “Continuous Fan” on the G terminal.
- F. If the above diagnostics do not solve the problem, confirm the voltage checks in the next section below, then continue with the **Model SelecTech Communication Diagnostics**.

**If the Motor Is Not Running**

- 1. Check for proper high voltage and ground at the L/ L1, G, N/L2 connections at the motor (see Figure 20). Correct any voltage issues before proceeding to the next step. The SelecTech motor is voltage specific. Only the correct voltage should be applied to the proper motor. Input voltage within plus or minus 10% of the nominal line power VAC is acceptable.

- 2. If the motor has proper high voltage and ground at the L/L1, G, N/L2 connections, then continue with the **Model SelecTech Communication Diagnostics**.

**Model SelecTech Communication Diagnostics**

The SelecTech motor is communicated through 24 VAC low voltage (thermostat control circuit wiring).

- 1. Start with unit wiring diagram to confirm proper connections and voltage (see Figure 21).
- 2. Initiate a demand from the thermostat and check the voltage between the common and the appropriate motor terminal (1-5). (G input is typically on terminal #1, but always refer to wiring diagram.)
  - A. If the low voltage communication is not present, check the demand from the thermostat. Also check the output terminal and wire(s) from the terminal strip or control relay(s) to the motor.
  - B. If the motor has proper high voltage (verified in Step 1 of **If the Motor Is Not Running**), proper low voltage to a programmed terminal and is not operating, the motor is failed and will require replacement.

**FIGURE 20**  
**Motor Connections**

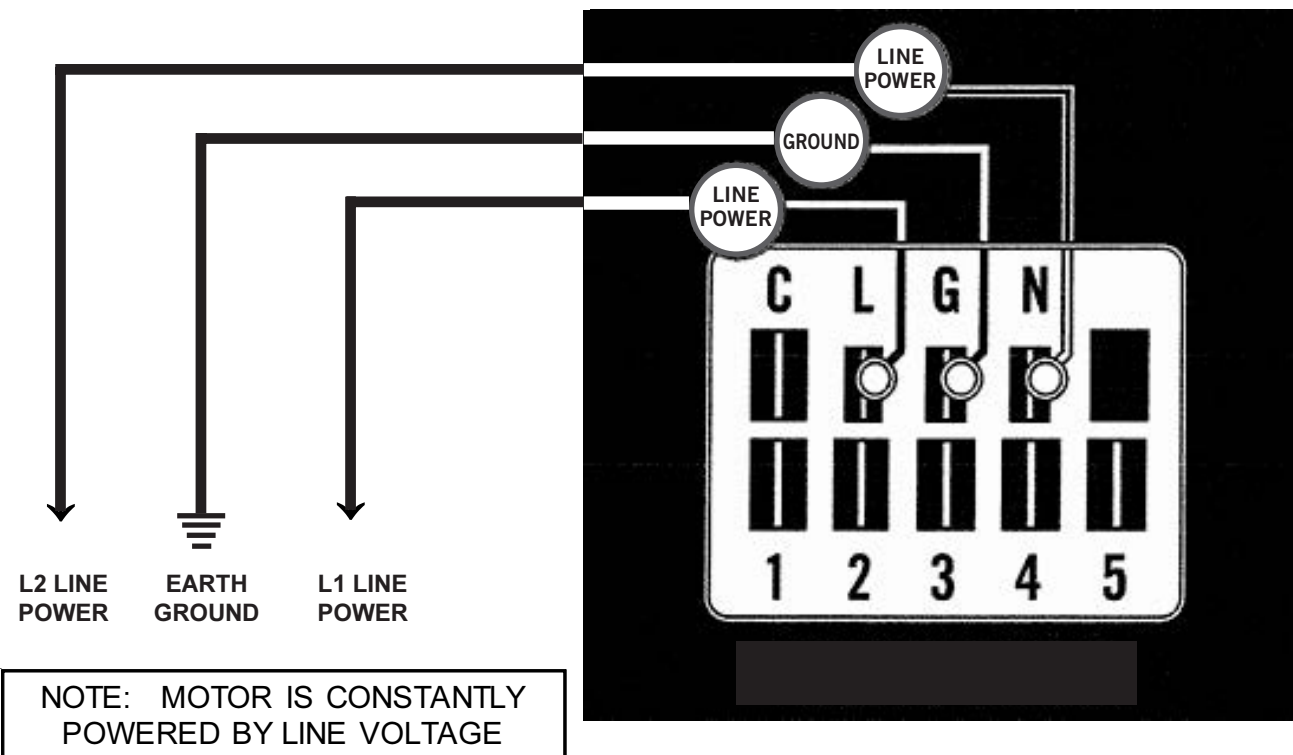
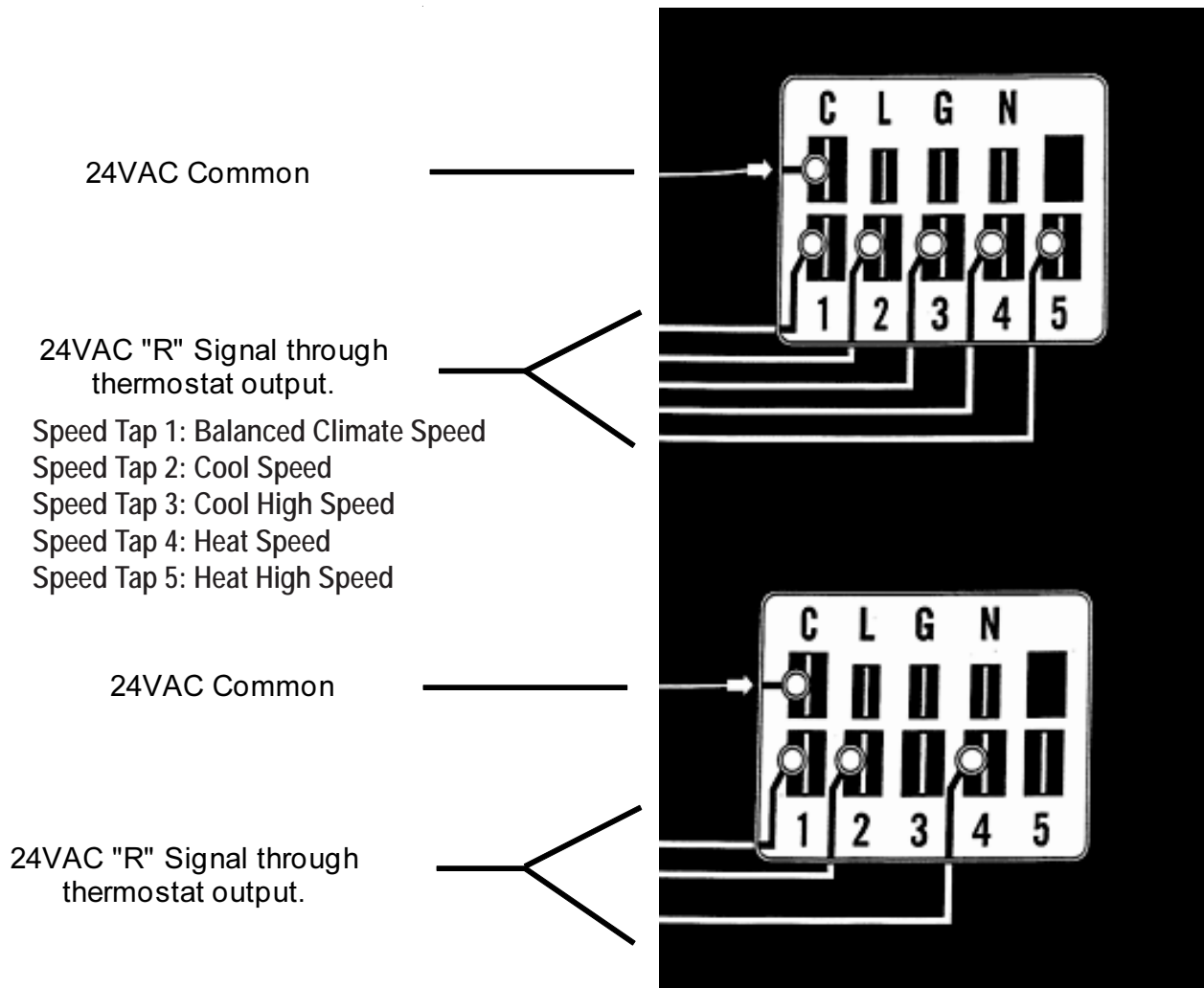

FIGURE 21  
Motor Connections



### 31. REPLACEMENT PARTS

## WARNING

Use replacement parts listed in Replacement Parts list. Failure to do so could cause improper furnace operation, resulting in property damage, personal injury or death.

Replacement parts for the gas/electric units are available through local distributors.

A replacement parts list manual is supplied with each unit. When ordering parts or making inquiries pertaining to any of the units covered by these

instructions, it is very important to always supply the **complete** model number and serial number of the unit. This is necessary to assure that the correct parts (or an approved alternate part) are issued to the service agency.

### 32. SEQUENCE OF OPERATION – HEATING

On a call for heat from the thermostat, the induced draft blower is energized. Once sufficient draft is established, the pressure switch contacts close and the ignition system is energized. The direct spark igniter will be energized allowing gas to flow. At the same time the main valve is energized, a 30-second blower delay timer is activated.

After this delay, the heating speed blower relay energizes. The blower will begin operating and remain in operation until the set delay time after the call for heat has been satisfied. This timing sequence guarantees blower on, blower off operation.

This unit is equipped with a flame roll-out switch, which is wired in series with the control circuit. This is a manual reset switch and is used for the purpose of preventing possible fire hazard in the event of a system malfunction. If this switch has opened the control circuit, there could be a possible system malfunction. Some of the conditions that might cause a roll-out to occur are blockage or sooting of primary heat exchanger, overfiring of furnace due to improper main burner orifices or incorrect manifold pressure, insufficient combustion air or installation deficiencies with respect to return air duct design or sizing.

Once the problem has been resolved, reset the switch by pressing down on the reset button on top of the switch. See Figure 22 for additional information.

### 33. SEQUENCE OF OPERATION – COOLING

On a call for cooling from the room thermostat, the blower relay will be energized as well as the compressor contactor. Following termination of the cooling cycle, the blower motor will continue to run for one minute.

See Figure 22 for additional information.

The unit may be equipped with a low ambient control for lower outdoor temperature operation in the cooling mode. If equipped with this optional control, the condenser fan will not operate immediately upon compressor start-up, and will cycle on and off until the condensing pressure remains above 180 PSIG. Low ambient control energizes the fan motor at 280 PSIG, de-energizes at 180 PSIG.

**FIGURE 22**  
**Sequence of Operation**  
**Electronic Blower Control**

Action	System Response
Thermostat calls for heat (W terminal is energized).	<ul style="list-style-type: none"> <li>• Combustion air blower is energized.</li> <li>• Air proving switch makes. Airflow is established.</li> <li>• Ignition system is energized.</li> <li>• Gas valve opens and main burner lights.</li> <li>• Heat fan on delay timing begins. When timing is complete, the circulating fan is energized at heat speed.</li> </ul>
Thermostat ends call for heat.	<ul style="list-style-type: none"> <li>• Ignition system is de-energized and gas valve closes.</li> <li>• Combustion air blower is de-energized after postpurge timing.</li> <li>• Heat fan off delay timing begins. When timing is complete, the circulating fan is de-energized.</li> </ul>
Thermostat begins call for cool (G and Y terminals energized).	<ul style="list-style-type: none"> <li>• Cooling contactor is energized.</li> <li>• Circulating fan is energized on cool speed after cool fan on delay timing.</li> </ul>
Thermostat begins call for fan (G terminal is energized).	<ul style="list-style-type: none"> <li>• Circulating fan is energized.</li> </ul>
Limit (flame rollout) opens.	<ul style="list-style-type: none"> <li>• Thermostat and ignition system are de-energized and gas valve closes.</li> <li>• Combustion air blower and circulating fan heat speed are energized.</li> </ul>
Limit (auto reset) or flame rollout (manual reset) circuit closed.	<ul style="list-style-type: none"> <li>• Combustion air blower remains energized for postpurge timing.</li> <li>• The circulation fan remains energized for the selected delay off timing.</li> <li>• Normal operation resumes.</li> </ul>

### 34. SETTING UNIT AIRFLOW

All models have multiple speed direct drive blower motors. If supply and return ducts are connected to the unit, the ducts must be of adequate size. Refer to the appropriate blower tables. See Tables 12, 13, 14, 15, 16 and 17 for maximum static pressures acceptable. Note the minimum CFM for Heating and Cooling operation.

The unit is set from the factory at the default speed. W\*\*G units have three (3) selectable speeds for cooling and two (2) selectable speeds for heating. First set the airflow for heating. For high static applications the speed should be set to high. When in doubt, note the allowable air temperature rise listed on the name plate and using the procedure listed in Section 23, "Measuring Air Temperature Rise", measure the air temperature rise. If the temperature rise is above allowable range, the heating airflow must be increased.

To increase the heating airflow speed:

- First disconnect power to the unit.
- Open the control panel and find the furnace control board (see Figure 23).

- Remove the black wire from the unused terminal and then remove the red wire from the heat terminal.
- Install the red wire on the unused terminal and the black wire on the heat terminal.
- Close the control panel and repeat the air temperature rise test.
- To reduce the heating airflow speed from high to standard, move the black wire from the heat terminal to the unused terminal and the red wire from the unused terminal to the heat terminal.

The default speed for cooling is the rated cooling speed that is listed in Tables 12, 13, 14, 15, 16 and 17. The higher cooling speed tap can be used for higher duct static applications or to increase the sensible cooling capacity. The higher speeds can also be used when higher sensible cooling is desired.

To increase the cooling airflow speed:

- First disconnect power to the unit.
- Open the control panel and find the terminal block above the blower relay (see Figure 24 on page 44).

**FIGURE 23**  
Increasing Heating Speed

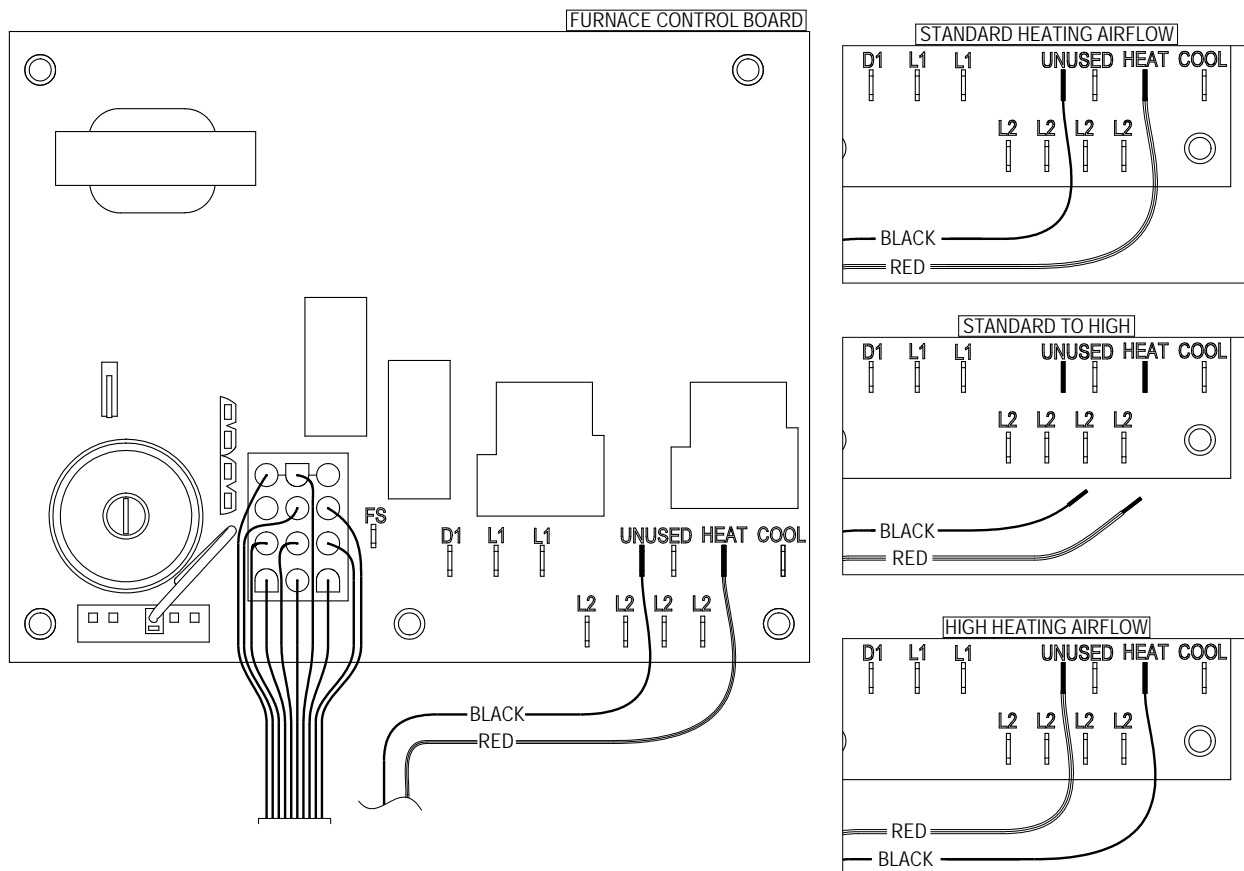

MIS-4138

**FIGURE 24**  
Increasing Cooling Speed

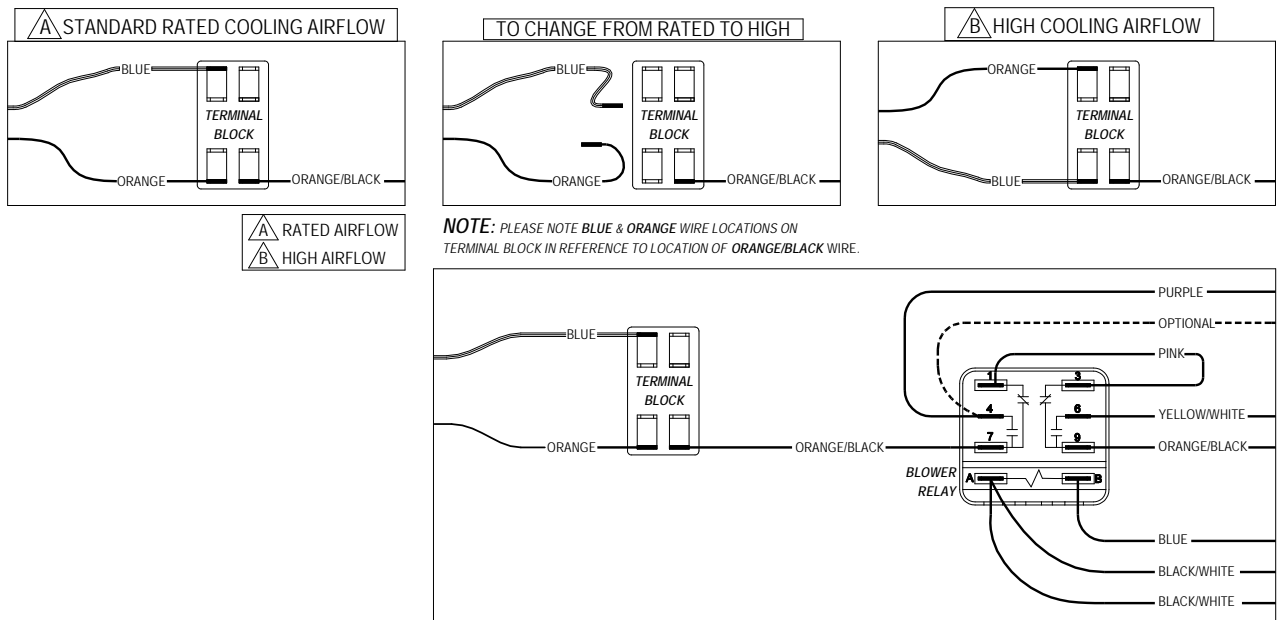

MIS-4139

- Locate the orange and blue wires on the terminal block below the furnace control board.
- Switch the terminal landings on the terminal block.
- Close the control panel.
- To reduce the cooling airflow speed from high to rated, reverse the blue and orange wires on the terminal block below the furnace control board.

**NOTE:** Be sure to adjust the system static or blower speed to maintain airflows above the minimum recommendations to prevent freeze up conditions if Balanced Climate mode is activated.

Do not operate the unit in Balanced Climate mode if running high static applications as indicated in the blower performance table. If Balanced Climate mode is activated as described on page 22, the unit will run in this mode at all times unless there is a call for ventilation, electric heat or 2nd stage cooling from a 2-stage thermostat. At that time, the unit will automatically activate a higher speed tap.

### Blower Speeds

Five factory programmed speed taps (torque settings) are available for the motor, and are selected through different unit modes of operation. These modes are energized by 24VAC signals from the low voltage terminal block located inside the control panel by a thermostat or other controlling device. Each speed tap is programmed by Bard at the factory to different motor torque settings (see Figure 25).

Multiple motor speed taps may be energized simultaneously by 24VAC power during different modes of operation. The highest number speed tap energized takes priority with 5 being the highest and 1 being the lowest.

**FIGURE 25**  
Speed Taps

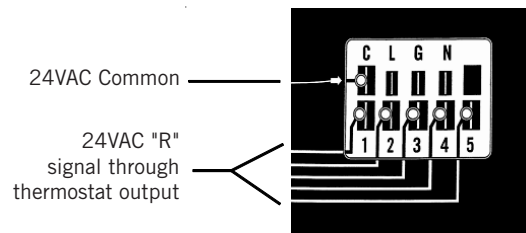

- Speed Tap 1: Balanced Climate Speed
- Speed Tap 2: Cool Speed
- Speed Tap 3: Cool High Speed
- Speed Tap 4: Heat Speed
- Speed Tap 5: Heat High Speed

**TABLE 12**  
**W24G4 Indoor Blower Performance @ 230 and 460 VOLTS**

Recommended W24G cooling airflow range at rated 800 CFM @ 0.10 ESP (WC) is 700 - 910 CFM  
Factory set on Rated speed for cooling and Medium speed for heating.

ESP Inches H <sub>2</sub> O	COOLING MODE			MANUAL FAN and HEATING MODE			
	Wet Coil			90,000 BTU Input		81,000 BTU Input	
	Balanced	Rated	High	Medium	High	Medium	High
0	670	928	1213				
0.1	598	851	1141	1361			
0.2	511	760	1055	1288	1373	1288	
0.3	417	662	962	1214	1324	1214	
0.4	323	564	870	1143	1278	1143	
0.5	235	473	784	1077	1237	1077	1237

ESP Inches H <sub>2</sub> O	COOLING MODE			MANUAL FAN and HEATING MODE			
	Wet Coil			68,000 BTU Input		61,000 BTU Input	
	Balanced	Rated	High	Medium	High	Medium	High
0	670	928	1213				
0.1	598	851	1141				
0.2	511	760	1055	1288			
0.3	417	662	962	1214			
0.4	323	564	870	1143	1278	1143	
0.5	235	473	784	1077	1237	1077	

ESP Inches H <sub>2</sub> O	COOLING MODE			MANUAL FAN and HEATING MODE			
	Wet Coil			45,000 BTU Input		41,000 BTU Input	
	Balanced	Rated	High	Medium	High	Medium	High
0	670	928	1213				
0.1	598	851	1141	1361			
0.2	511	760	1055	1288			
0.3	417	662	962	1214	1324		
0.4	323	564	870	1143	1278	1143	
0.5	235	473	784	1077	1237	1077	

**SG-3, RG-3, non-ducted application adjustment** – Reduce airflow by 100 CFM for SG-3 and RG-3 installations

**TABLE 13**  
**W30G4 Indoor Blower Performance @ 230 AND 460 VOLTS**

Recommended W30G cooling airflow range at rated 900 CFM @ 0.15 ESP (WC) is 750 - 1150 CFM  
Factory set on **Rated speed for cooling and Medium speed for heating.**

ESP Inches H <sub>2</sub> O	COOLING MODE			MANUAL FAN and HEATING MODE			
	Wet Coil			90,000 BTU Input		81,000 BTU Input	
	Balanced	Rated	High	Medium	High	Medium	High
0	850	1022	1157	1281			
0.1	769	953	1098	1237	1375	1237	
0.2	688	883	1038	1188	1329	1188	
0.3	606	812	975	1134	1279	1134	
0.4	523	739	910	1075	1225	1075	1225
0.5	439	664	843	1011	1168	1011	1168

ESP Inches H <sub>2</sub> O	COOLING MODE			MANUAL FAN and HEATING MODE			
	Wet Coil			68,000 BTU Input		61,000 BTU Input	
	Balanced	Rated	High	Medium	High	Medium	High
0	850	1022	1157	1281			
0.1	769	953	1098	1237			
0.2	688	883	1038	1188			
0.3	606	812	975	1134	1279	1134	
0.4	523	739	910	1075	1225	1075	
0.5	439	664	843	1011	1168	1011	

ESP Inches H <sub>2</sub> O	COOLING MODE			MANUAL FAN and HEATING MODE			
	Wet Coil			45,000 BTU Input		41,000 BTU Input	
	Balanced	Rated	High	Medium	High	Medium	High
0	850	1022	1157	1281			
0.1	769	953	1098	1237			
0.2	688	883	1038	1188	1329	1188	
0.3	606	812	975	1134	1279	1134	
0.4	523	739	910	1075	1225	1075	
0.5	439	664	843	1011	1168	1011	1168

**Dehumidification coil adjustment** – Reduce airflow by 35 CFM for dehumidification coil installed  
**SG-3, RG-3, non-ducted application adjustment** – Reduce airflow by 100 CFM for SG-3 and RG-3 installations



**TABLE 14**  
**W36G4 Indoor Blower Performance @ 230 AND 460 VOLTS**

Recommended W36G cooling airflow range at rated 1100 CFM @ 0.10 ESP (WC) is 940 - 1250 CFM  
Factory set on Rated speed for cooling and Medium speed for heating.

ESP Inches H <sub>2</sub> O	COOLING MODE			MANUAL FAN and HEATING MODE			
	Wet Coil			90,000 BTU Input		81,000 BTU Input	
	Balanced	Rated	High	Medium	High	Medium	High
0	932	1202	1281	1281			
0.1	855	1148	1238	1237	1375	1237	
0.2	776	1091	1190	1188	1329	1188	
0.3	695	1030	1139	1134	1279	1134	
0.4	614	966	1083	1075	1225	1075	1225
0.5	530	898	1022	1011	1168	1011	1168

ESP Inches H <sub>2</sub> O	COOLING MODE			MANUAL FAN and HEATING MODE			
	Wet Coil			68,000 BTU Input		61,000 BTU Input	
	Balanced	Rated	High	Medium	High	Medium	High
0	932	1202	1281	1281			
0.1	855	1148	1238	1237			
0.2	776	1091	1190	1188			
0.3	695	1030	1139	1134	1279	1134	
0.4	614	966	1083	1075	1225	1075	
0.5	530	898	1022	1011	1168	1011	

ESP Inches H <sub>2</sub> O	COOLING MODE			MANUAL FAN and HEATING MODE			
	Wet Coil			45,000 BTU Input		41,000 BTU Input	
	Balanced	Rated	High	Medium	High	Medium	High
0	932	1202	1281	1281			
0.1	855	1148	1238	1237			
0.2	776	1091	1190	1188	1329	1188	
0.3	695	1030	1139	1134	1279	1134	
0.4	614	966	1083	1075	1225	1075	
0.5	530	898	1022	1011	1168	1011	1168

**SG-3, RG-3, non-ducted application adjustment** – Reduce airflow by 100 CFM for SG-3 and RG-3 installations

**TABLE 15**  
**W42G4 Indoor Blower Performance @ 230 AND 460 VOLTS**

Recommended W42G cooling airflow range at rated 1300 CFM @ .15 ESP (WC) is 1030 - 1480 CFM  
Factory set on Rated speed for cooling and Medium speed for heating.

ESP Inches H <sub>2</sub> O	COOLING MODE			MANUAL FAN and HEATING MODE			
	Wet Coil			125,000 BTU Input		113,000 BTU Input	
	Balanced	Rated	High	Medium	High	Medium	High
0	1084	1394	1552	1788			
0.1	1011	1335	1498	1734			
0.2	930	1270	1439	1678		1678	
0.3	840	1198	1374	1618		1618	
0.4	741	1119	1305	1557	1811	1557	
0.5	633	1034	1230	1492	1754	1492	

ESP Inches H <sub>2</sub> O	COOLING MODE			MANUAL FAN and HEATING MODE			
	Wet Coil			100,000 BTU Input		90,000 BTU Input	
	Balanced	Rated	High	Medium	High	Medium	High
0	1084	1394	1552	1788			
0.1	1011	1335	1498	1734		1734	
0.2	930	1270	1439	1678		1678	
0.3	840	1198	1374	1618	1870	1618	
0.4	741	1119	1305	1557	1811	1557	
0.5	633	1034	1230	1492	1754	1492	

ESP Inches H <sub>2</sub> O	COOLING MODE			MANUAL FAN and HEATING MODE			
	Wet Coil			75,000 BTU Input		68,000 BTU Input	
	Balanced	Rated	High	Medium	High	Medium	High
0	1084	1394	1552	1788			
0.1	1011	1335	1498	1734			
0.2	930	1270	1439	1678		1678	
0.3	840	1198	1374	1618	1870	1618	
0.4	741	1119	1305	1557	1811	1557	
0.5	633	1034	1230	1492	1754	1492	

**SG-5, RG-5, non-ducted application adjustment** – Reduce airflow by 170 CFM for SG-5 and RG-5 installations

**TABLE 16**  
**W48G4 Indoor Blower Performance @ 230 AND 460 VOLTS**

Recommended W48G cooling airflow range at rated 1450 CFM @ .20 ESP (WC) is 1150 - 1680 CFM  
 Factory set on Rated speed for cooling and Medium speed for heating.

ESP Inches H <sub>2</sub> O	COOLING MODE			MANUAL FAN and HEATING MODE			
	Wet Coil			125,000 BTU Input		113,000 BTU Input	
	Balanced	Rated	High	Medium	High	Medium	High
0	1185	1501	1668	1788			
0.1	1118	1445	1616	1734			
0.2	1042	1384	1560	1678		1678	
0.3	958	1317	1500	1618		1618	
0.4	866	1245	1436	1557	1811	1557	
0.5	766	1167	1368	1492	1754	1492	

ESP Inches H <sub>2</sub> O	COOLING MODE			MANUAL FAN and HEATING MODE			
	Wet Coil			100,000 BTU Input		90,000 BTU Input	
	Balanced	Rated	High	Medium	High	Medium	High
0	1185	1501	1668	1788			
0.1	1118	1445	1616	1734		1734	
0.2	1042	1384	1560	1678		1678	
0.3	958	1317	1500	1618	1870	1618	
0.4	866	1245	1436	1557	1811	1557	
0.5	766	1167	1368	1492	1754	1492	

ESP Inches H <sub>2</sub> O	COOLING MODE			MANUAL FAN and HEATING MODE			
	Wet Coil			75,000 BTU Input		68,000 BTU Input	
	Balanced	Rated	High	Medium	High	Medium	High
0	1185	1501	1668	1788			
0.1	1118	1445	1616	1734			
0.2	1042	1384	1560	1678		1678	
0.3	958	1317	1500	1618	1870	1618	
0.4	866	1245	1436	1557	1811	1557	
0.5	766	1167	1368	1492	1754	1492	

**SG-5, RG-5, non-ducted application adjustment** – Reduce airflow by 170 CFM for SG-5 and RG-5 installations

**TABLE 17**  
**W60G4 Indoor Blower Performance @ 230 AND 460 VOLTS**

Recommended W60G cooling airflow range at rated 1650 CFM @ .20 ESP (WC) is 1360 - 1850 CFM  
 Factory set on Rated speed for cooling and Medium speed for heating.

ESP Inches H <sub>2</sub> O	COOLING MODE			MANUAL FAN and HEATING MODE			
	Wet Coil			125,000 BTU Input		113,000 BTU Input	
	Balanced	Rated	High	Medium	High	Medium	High
0	1347	1771	1881	1743			
0.1	1272	1708	1823	1682			
0.2	1199	1646	1766	1619	1843	1619	
0.3	1128	1584	1709	1554	1783	1554	
0.4	1060	1523	1652	1486	1721	1486	
0.5	994	1462	1596	1417	1657	1417	1657

ESP Inches H <sub>2</sub> O	COOLING MODE			MANUAL FAN and HEATING MODE			
	Wet Coil			100,000 BTU Input		90,000 BTU Input	
	Balanced	Rated	High	Medium	High	Medium	High
0	1347	1771	1881	1743			
0.1	1272	1708	1823	1682		1682	
0.2	1199	1646	1766	1619	1843	1619	
0.3	1128	1584	1709	1554	1783	1554	
0.4	1060	1523	1652	1486	1721	1486	1721
0.5	994	1462	1596	1417	1657	1417	1657

ESP Inches H <sub>2</sub> O	COOLING MODE			MANUAL FAN and HEATING MODE			
	Wet Coil			75,000 BTU Input		68,000 BTU Input	
	Balanced	Rated	High	Medium	High	Medium	High
0	1347	1771	1881	1743			
0.1	1272	1708	1823	1682		1682	
0.2	1199	1646	1766	1619	1843	1619	
0.3	1128	1584	1709	1554	1783	1554	
0.4	1060	1523	1652	1486	1721	1486	1721
0.5	994	1462	1596	1417	1657	1417	1657

**SG-5, RG-5, non-ducted application adjustment** – Reduce airflow by 170 CFM for SG-5 and RG-5 installations

**TABLE 18**  
**Integrated Furnace and Blower Control Operation**

**IGNITION SEQUENCE CONTROL**

Ignition Source	24 VAC DSI
Flame Sensing	Remote
Timings	
- Prepurge	15 seconds
- Postpurge	30 seconds (0 if cycle terminated before valve "on")
- Inter-trial purge	15 seconds
- Pressure switch proving period	60 seconds
- Trials for ignition	3 per ignition sequence
- Trial for ignition	7 seconds total time to prove flame
- Ignition sequence lockout	60 minutes (after 3 trials for ignition), auto reset - can be reset during the 60-minute lockout period by opening thermostat circuit for 3 seconds or more
- Heat blower on - delay	30 seconds (timing starts when ignitor cycles off)
- Heat blower off - delay	90, 120, 150 seconds selectable; factory set at 120
- Cool blower on - delay	7 seconds
- Cool blower off - delay	60 seconds
- Manual fan operations	Operates on selected heating speed and cycles off during ignition or burner start-up sequence.
- High limit control operation	Automatic reset, ignition sequence restart. See Note 1.
- Flame rollout switch operation	Manual reset, ignition sequence initiated after switch is manually reset. See Note 1.

*NOTE 1: After the fourth limit trip on a given call for heat, there will be a 1-hour delay before the ignition sequence will restart. After either high limit switch or flame rollout switch actuation, the inducer will operate for the 30-second postpurge and the comfort air blower will operate for the selected off delay. If on Manual Fan operation, the comfort air blower will continue to operate.*

**SAFETY UNITS**

High limit/Rollout	SPST in 24 Volt
Pressure switch	SPST, safe start check

**COMFORT FAN CONTROL**

**Heating Speed Fan**

Normal operation	
- ON delay	30 seconds fixed. Timing starts when igniter de-energized.
- OFF delay	3 selectable timings – 120 seconds standard can be changed to 90 or 150 seconds.
Limit Operation	ON when limit OPEN OFF after OFF delay when limit CLOSES
Flame Sense	ON if flame is sensed <i>and</i> there is no call for heat.

**Cooling Speed Fan**

- ON delay	7 seconds
- OFF delay	60 seconds

**Manual Fan**

ON continuously on HEATING speed. When call for cool, the fan switches to COOLING speed. Then when thermostat satisfied, the fan switches back to HEATING speed after COOLING OFF delay.

**DIAGNOSTIC INDICATOR**

A red LED is provided to indicate system faults as follows:

- Steady ON - Control okay in standby, call for heat, cool or fan modes
- Steady OFF - Internal control fault or no power. Also check 3A fuse on control.
- 1 flash - Lockout due to failed ignition or flame dropouts
- 2 flashes - Pressure switch open with inducer on
- 3 flashes - Pressure switch is closed with inducer off
- 4 flashes - Limit switch is open
- 5 flashes - Flame detected with gas valve closed
- 6 flashes - Compressor output delayed from short cycle/staging timer

The flash rate is 0.25 seconds on, 0.25 seconds off with 2.0 seconds pause between flash codes.

### 35. PRESSURE SERVICE PORTS

High and low pressure service ports are installed on all units so that the system operating pressures can be observed. Table 19 outlines expected pressures at various indoor and outdoor temperatures.

This unit employs high-flow Coremax valves instead of the typical Schrader type valves.

**WARNING! Do NOT use a Schrader valve core removal tool with these valves. Use of such a tool could result in eye injuries or refrigerant burns!**

To change a Coremax valve without first removing the refrigerant, a special tool is required which can be obtained at [www.fastestinc.com/en/SCCA07H](http://www.fastestinc.com/en/SCCA07H). See the replacement parts manual for replacement core part numbers.

**TABLE 19**  
**Cooling Pressure Table**

Model	Return Air Temperature	Pressure	75°	80°	85°	90°	95°	100°	105°	110°	115°	120°	125°
W24G4	75° DB 62° WB	Low Side	119.7	122.6	125.3	127.9	130.3	132.8	135.0	137.2	139.1	141.0	142.8
		High Side	298.0	318.5	340.2	363.0	386.9	411.8	438.0	465.3	493.6	523.2	553.8
	80° DB 67° WB	Low Side	128.0	131.1	134.0	136.8	139.4	142.0	144.4	146.7	148.8	150.8	152.7
		High Side	305.6	326.7	348.9	372.3	396.8	422.4	449.2	477.2	506.3	536.6	568.0
	85° DB 72° WB	Low Side	132.5	135.7	138.7	141.6	144.3	147.0	149.5	151.8	154.0	156.1	158.0
		High Side	316.3	338.1	361.1	385.3	410.7	437.2	464.9	493.9	524.0	555.4	587.9
W30G4	75° DB 62° WB	Low Side	120.1	122.7	125.2	127.6	130.0	132.3	134.5	136.8	138.9	141.0	143.1
		High Side	297.7	318.0	339.5	362.0	385.5	410.0	435.5	462.2	489.7	518.4	548.1
	80° DB 67° WB	Low Side	128.5	131.2	133.9	136.5	139.0	141.5	143.9	146.3	148.6	150.8	153.0
		High Side	305.3	326.2	348.2	371.3	395.4	420.5	446.7	474.0	502.3	531.7	562.2
	85° DB 72° WB	Low Side	133.0	135.8	138.6	141.3	143.9	146.5	148.9	151.4	153.8	156.1	158.4
		High Side	316.0	337.6	360.4	384.3	409.2	435.2	462.3	490.6	519.9	550.3	581.9
W36G4	75° DB 62° WB	Low Side	124.4	126.8	129.1	131.3	133.4	135.4	137.4	139.1	140.9	142.6	144.2
		High Side	312.6	334.9	357.9	381.6	405.9	431.0	456.7	483.1	510.2	538.0	566.5
	80° DB 67° WB	Low Side	133.1	135.6	138.1	140.4	142.7	144.8	146.9	148.8	150.7	152.5	154.2
		High Side	320.6	343.5	367.1	391.4	416.3	442.0	468.4	495.5	523.3	551.8	581.0
	85° DB 72° WB	Low Side	137.8	140.3	142.9	145.3	147.7	149.9	152.0	154.0	156.0	157.8	159.6
		High Side	331.8	355.5	379.9	405.1	430.9	457.5	484.9	512.8	541.6	571.1	601.3
W42G4	75° DB 62° WB	Low Side	124.7	127.4	130.0	132.3	134.6	136.7	138.8	140.6	142.3	143.9	145.4
		High Side	328.7	350.3	373.0	396.7	421.4	447.1	473.8	501.4	530.1	559.7	590.4
	80° DB 67° WB	Low Side	133.4	136.3	139.0	141.5	144.0	146.2	148.4	150.4	152.2	153.9	155.5
		High Side	337.1	359.3	382.6	406.9	432.2	458.6	485.9	514.3	543.7	574.1	605.5
	85° DB 72° WB	Low Side	138.1	141.1	143.9	146.5	149.0	151.3	153.6	155.7	157.5	159.3	
		High Side	348.9	371.9	396.0	421.1	447.3	474.7	502.9	532.3	562.7	594.2	
W48G4	75° DB 62° WB	Low Side	124.9	126.8	128.7	130.4	132.2	134.0	135.8	137.5	139.3	141.0	142.7
		High Side	325.9	347.5	369.8	392.9	416.9	441.7	467.2	493.6	520.8	548.9	577.8
	80° DB 67° WB	Low Side	133.6	135.6	137.6	139.5	141.4	143.3	145.2	147.1	149.0	150.8	152.6
		High Side	334.3	356.4	379.3	403.0	427.6	453.0	479.2	506.3	534.2	563.0	592.6
	85° DB 72° WB	Low Side	138.3	140.3	142.4	144.4	146.3	148.3	150.3	152.2	154.2	156.1	157.9
		High Side	346.0	368.9	392.6	417.1	442.6	468.9	496.0	524.0	552.9	582.7	613.3
W60G4	75° DB 62° WB	Low Side	123.3	125.1	127.0	128.8	130.6	132.5	134.3	136.1	137.9	139.8	141.6
		High Side	309.0	329.6	351.4	374.2	398.2	423.3	449.6	477.0	505.5	535.2	566.0
	80° DB 67° WB	Low Side	131.9	133.8	135.8	137.8	139.7	141.7	143.6	145.6	147.5	149.5	151.4
		High Side	316.9	338.1	360.4	383.8	408.4	434.2	461.1	489.2	518.5	548.9	580.5
	85° DB 72° WB	Low Side	136.5	138.5	140.6	142.6	144.6	146.7	148.6	150.7	152.7	154.7	156.7
		High Side	328.0	349.9	373.0	397.2	422.7	449.4	477.2	506.3	536.6	568.1	600.8

Low side pressure ± 4 PSIG High side pressure ±10 PSIG

Tables based upon rated CFM (airflow) across the evaporator coil.

If there is any doubt as to correct operating charge being in the system, the charge should be reclaimed, and the system evacuated and recharged to serial plate instruction.

### 36. R-410A REFRIGERANT CHARGE

This unit was charged at the factory with the quantity of refrigerant listed on the serial plate. AHRI capacity and efficiency ratings were determined by testing with this refrigerant charge quantity.

Table 19 shows nominal pressures for the units. Since many installation specific situations can affect the pressure readings, this information should only be used by certified technicians as a guide for evaluating proper system performance. They shall not be used to adjust charge. If charge is in doubt, reclaim, evacuate and recharge the unit to the serial plate charge.

### 37. FAN BLADE SETTING DIMENSIONS

The correct fan blade setting dimension for proper air delivery across the outdoor coil is shown in Figure 26.

**FIGURE 26**  
Fan Blade

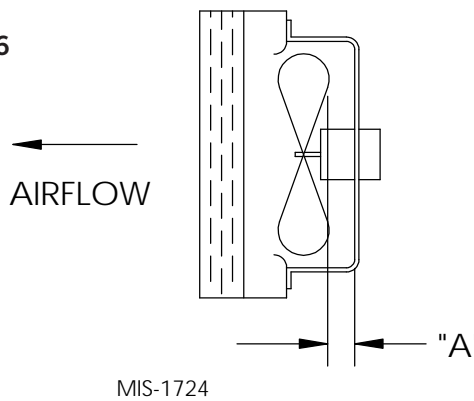

**TABLE 20**  
Fan Blade Dimension

Model	Dimension A
W24G	1.25
W30G	1.25
W36G	1.25
W42G	1.75
W48G	1.75
W60G	1.75

### 38. LOW-NOX BURNER ASSEMBLY "N" SUFFIX MODELS ONLY – U.S. INSTALLATIONS ONLY

#### Natural Gas Models Only

Model numbers designated with an "N" are designed for low NOx emissions which comply with all California Air Quality Management District regulations for nitrogen oxide emission levels. Refer to Figure 27 for NOx insert information.

#### **\*\* IMPORTANT \*\***

For propane (LP) conversions, the NOx reduction screen inserts shown below must be removed. This is accomplished by removing the burner box assembly and removing the NOx screens. Reassemble unit properly before firing. Failure to remove the NOx screens can result in improper operation and malfunction of the burner system.

**FIGURE 27**  
Low NOx Insert

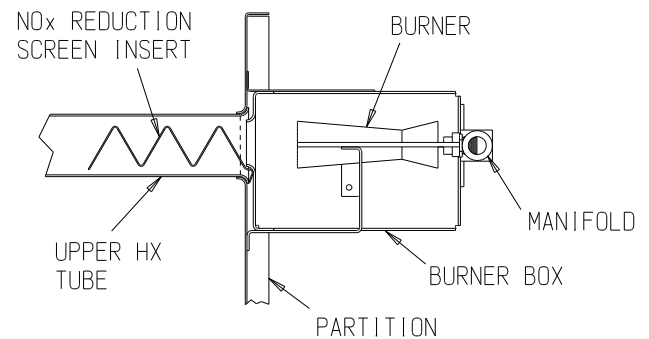

# INDEX

## Wiring Diagrams

<b>Unit Model No.</b>	<b>Basic Wiring Diagram</b>
W24G4-A	4085-177
W24G4-B	4085-277
W24G4-C	4085-400
W30G4-A	4085-177
W30G4-B	4085-277
W30G4-C	4085-400
W36G4-A	4085-177
W36G4-B	4085-277
W36G4-C	4085-400
W42G4-A	4085-177
W42G4-B	4085-277
W42G4-C	4085-400
W48G4-A	4085-177
W48G4-B	4085-277
W48G4-C	4085-400
W60G4-A	4085-175
W60G4-B	4085-275
W60G4-C	4085-398





---

# REPLACEMENT PARTS MANUAL

---

## Wall Mounted Gas/Electric

Models:

W24G4-A	W30G4-A	W36G4-A	W24G4DA	W30G4DA	W36G4DA
W24G4-B	W30G4-B	W36G4-B	W24G4DB	W30G4DB	W36G4DB
W24G4-C	W30G4-C	W36G4-C	W24G4DC	W30G4DC	W36G4DC

---

### Contents

<i>Description</i>	<i>Page</i>
Cabinet Components	
♦ Exploded View .....	2
♦ Usage List .....	3
♦ Usage List .....	4
♦ Usage List .....	5
Functional Components	
♦ Exploded View .....	6
♦ Usage List .....	7
♦ Usage List .....	8
Burner Components	
♦ Exploded View .....	10
♦ Usage List .....	11
♦ Usage List .....	12
♦ Usage List .....	13
Control Panel	
♦ Layout View .....	14
♦ Usage List .....	15
♦ Usage List .....	16
Blower Assembly	
♦ Exploded View .....	17
♦ Usage List .....	17

### General Notes

- Revised and/or additional pages may be issued from time to time.
- A complete and current manual consists of pages shown in the following contents section.

### Important

- Contact the installing and/or local Bard distributor for all parts requirements. Make sure to have the complete model and serial number available from the unit rating plates.



*Climate Control Solutions*

Bard Manufacturing Company, Inc.  
Bryan, Ohio 43506  
www.bardhvac.com

Manual: 2110-821F  
Supersedes: 2110-821E  
Date: 9-24-21

# CABINET COMPONENTS - STANDARD & DEHUMIDIFICATION

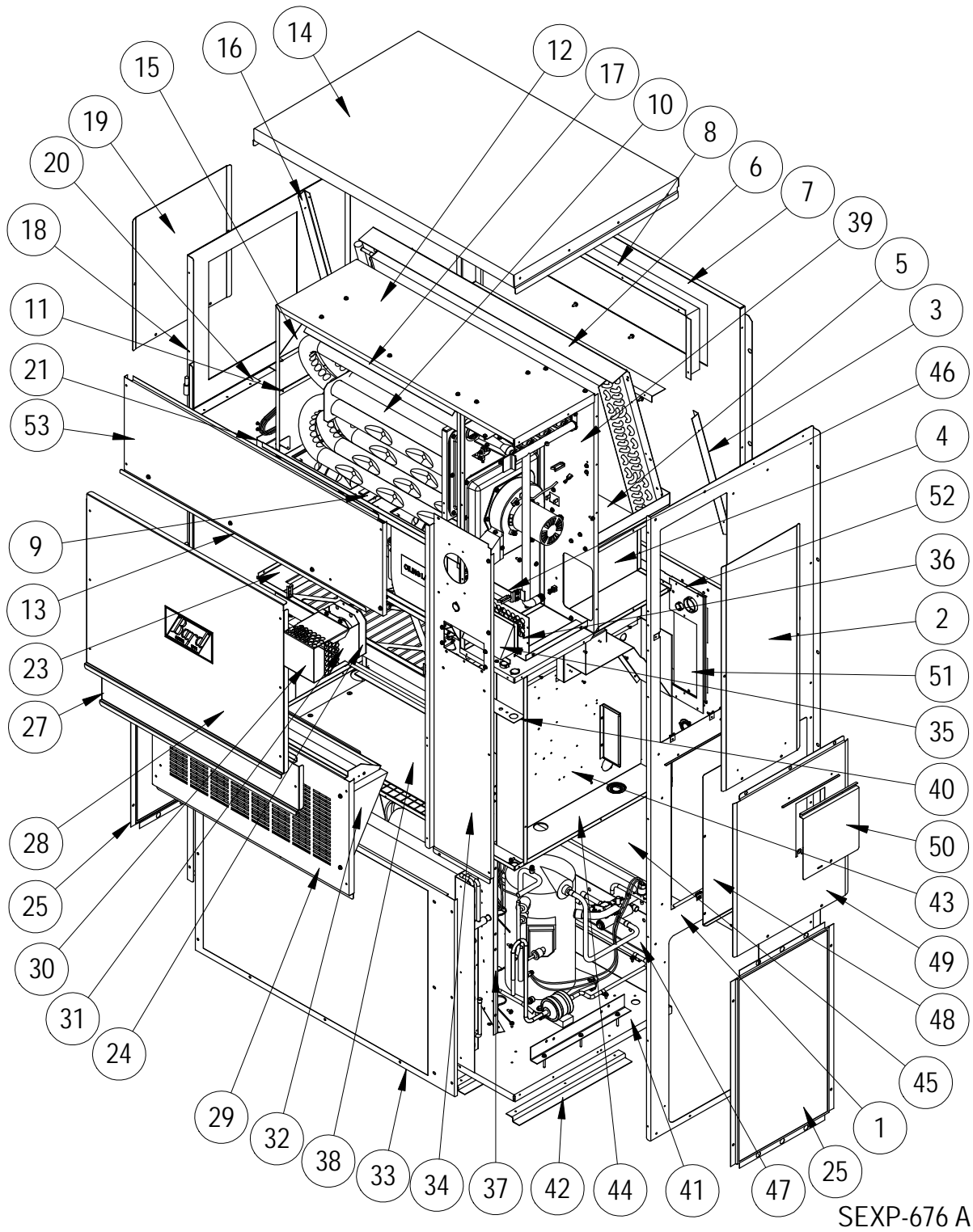

This drawing to be used as reference for pages 3, 4 and 5

# CABINET COMPONENTS – STANDARD & DEHUMIDIFICATION

---

Drawing No.	Part No.	Description	All Models
1	501-568-*	Right Side Assembly	X
2	S153-347-*	Vestibule Service Door	X
3	105X1073	Right Evaporator Support Angle	X
4	541-285	Right Drain Pan Support Assembly	X
5	S523-124	Drain Pan Assembly	X
6	105-1115	Evaporator Coil Fill Angle	X
7	509-166	Upper Back	X
8	111-091	Supply Air Frame	2
9	103-452	Heat Exchanger Support Offset	X
10	Heat Exch Assy	See Burner Components Diagram	
12	135-217	Inner Air Baffle	X
13	165-620-*	Rain Channel	X
14	507-242-*	Top Assembly	X
15	135-201	Right Heat Exchanger Partition	X
16	105Y1073	Left Evaporator Support Angle	X
17	105-1113	Top Heat Exchanger Deflector	X
18	501-748-*	Left Side Assembly	X
19	543-070-*	Left Access Cover	X
20	105-1108	Left Support Angle	X
21	S121-469	Blower Partition	X
23	S919-0008	Filter Tray	X
24	1921-051	Vent Terminal Gasket	X
25	118-083-*	Side Grille	2
<i>Continued on page 4 for standard units and on page 5 for dehumidification units</i>			

\* Exterior cabinet parts are manufactured with various paint color options. To ensure the proper paint color is received, include the complete model number and serial number of the unit for which parts are being ordered.

# CABINET COMPONENTS – STANDARD

Drawing No.	Part No.	Description	W24G4-A	W24G4-B	W24G4-C	W30G4-A	W30G4-B	W30G4-C	W36G4-A	W36G4-B	W36G4-C
<i>Continued from page 3</i>											
27	553-560-*	Filter Access Panel Assembly	X	X	X	X	X	X	X	X	X
28	S553-559-*	Front Door Assembly	X	X	X	X	X	X	X	X	X
29	553-346-*	Vent Option Door Assembly	X	X	X	X	X	X	X	X	X
30	169-119	Outer Vent Hood	X	X	X	X	X	X	X	X	X
31	169-120	Inner Vent Hood	X	X	X	X	X	X	X	X	X
32	WGBFAD-3	Barometric Fresh Air Damper	X	X	X	X	X	X	X	X	X
33	118-059-*	Condenser Grille	X	X	X	X	X	X	X	X	X
34	549-131-*	Right Front Corner Assembly	X	X	X	X	X	X	X	X	X
35	S135-181-*	Air Intake Hood	X	X	X	X	X	X	X	X	X
36	S134-182-*	Air Intake Back	X	X	X	X	X	X	X	X	X
37	125-022	Fan Shroud	X	X	X	X	X	X	X	X	X
38	542-138	Condensor Partition Blank Off Plate	X	X	X	X	X	X	X	X	X
39	541-402	Heat Exchanger Support Assembly	X	X	X	X	X	X	X	X	X
40	142-080	Filter Blank Off Plate	X	X	X	X	X	X	X	X	X
41	127-404	Lower Base	X	X	X	X	X	X	X	X	X
42	103-449	Lower Base Offset	3	3	3	3	3	3	3	3	3
43	517-408	Control Panel Assembly	X	X	X	X	X	X	X	X	X
44	521-441	Condenser Partition Assembly	X	X	X	X	X	X	X	X	X
45	509-167	Lower Back Assembly	X	X	X	X	X	X	X	X	X
46	113-268	Manifold Bracket	X	X	X	X	X	X	X	X	X
47	113-140	Bottom Support Bracket	X	X	X	X	X	X	X	X	X
48	S133-163	Circuit Breaker Inner Door	X	X		X	X		X	X	
48	S133-318	Toggle Disconnect Inner Door			X			X			X
49	S533-162-*	Control Panel Cover Assembly	X	X	X	X	X	X	X	X	X
50	S153-328-*	Disconnect Access Door	X	X	X	X	X	X	X	X	X
51	134-199	Conduit Access Panel	X	X	X	X	X	X	X	X	X
52	156-030	Conduit Entrance Plate	X	X	X	X	X	X	X	X	X
53	553-742-*	Upper Door Assembly	X	X	X	X	X	X	X	X	X
NS	5252-033	Bard Nameplate	X	X	X	X	X	X	X	X	X

\* Exterior cabinet parts are manufactured with various paint color options. To ensure the proper paint color is received, include the complete model number and serial number of the unit for which parts are being ordered.

NS – Not Shown

Refer to drawing on page 2

## CABINET COMPONENTS – DEHUMIDIFICATION

Drawing No.	Part No.	Description	W24G4DA	W24G4DB	W24G4DC	W30G4DA	W30G4DB	W30G4DC	W36G4DA	W36G4DB	W36G4DC
<i>Continued from page 3</i>											
27	553-560-*	Filter Access Panel Assembly	X	X	X	X	X	X	X	X	X
28	S553-559-*	Front Door Assembly	X	X	X	X	X	X	X	X	X
29	553-346-*	Vent Option Door Assembly	X	X	X	X	X	X	X	X	X
30	169-119	Outer Vent Hood	X	X	X	X	X	X	X	X	X
31	169-120	Inner Vent Hood	X	X	X	X	X	X	X	X	X
32	WGBFAD-3	Barometric Fresh Air Damper	X	X	X	X	X	X	X	X	X
33	118-059-*	Condenser Grille	X	X	X	X	X	X	X	X	X
34	549-131-*	Right Front Corner Assembly	X	X	X	X	X	X	X	X	X
35	S135-181-*	Air Intake Hood	X	X	X	X	X	X	X	X	X
36	S134-182-*	Air Intake Back	X	X	X	X	X	X	X	X	X
37	125-022	Fan Shroud	X	X	X	X	X	X	X	X	X
38	542-138	Cond. Block Off Plate Assembly	X	X	X	X	X	X	X	X	X
39	541-402	Heat Exchanger Support Assembly	X	X	X	X	X	X	X	X	X
40	142-080	Filter Blank Off Plate	X	X	X	X	X	X	X	X	X
41	127-318	Lower Base	X	X	X	X	X	X	X	X	X
42	103-449	Lower Base Offset	3	3	3	3	3	3	3	3	3
43	517-408	Control Panel Assembly	X	X	X	X	X	X	X	X	X
44	521-441	Condenser Partition Assembly	X	X	X	X	X	X	X	X	X
45	509-167	Lower Back Assembly	X	X	X	X	X	X	X	X	X
46	113-268	Manifold Bracket	X	X	X	X	X	X	X	X	X
47	113-140	Bottom Support Bracket	X	X	X	X	X	X	X	X	X
48	S133-163	Circuit Breaker Inner Door	X	X		X	X		X	X	
48	S133-318	Toggle Disconnect Inner Door			X			X			X
49	S533-162-*	Control Panel Cover Assembly	X	X	X	X	X	X	X	X	X
50	S153-328-*	Disconnect Access Door	X	X	X	X	X	X	X	X	X
51	134-199	Conduit Access Panel	X	X	X	X	X	X	X	X	X
52	156-030	Conduit Entrance Plate	X	X	X	X	X	X	X	X	X
53	553-742-*	Upper Door Assembly	X	X	X	X	X	X	X	X	X
NS	5252-033	Bard Nameplate	X	X	X	X	X	X	X	X	X

\* Exterior cabinet parts are manufactured with various paint color options. To ensure the proper paint color is received, reference the following codes: Beige -X, Buckeye Gray -4, Dark Bronze -8

NS – Not Shown

**Refer to drawing on page 2**

# FUNCTIONAL COMPONENTS – STANDARD & DEHUMIDIFICATION

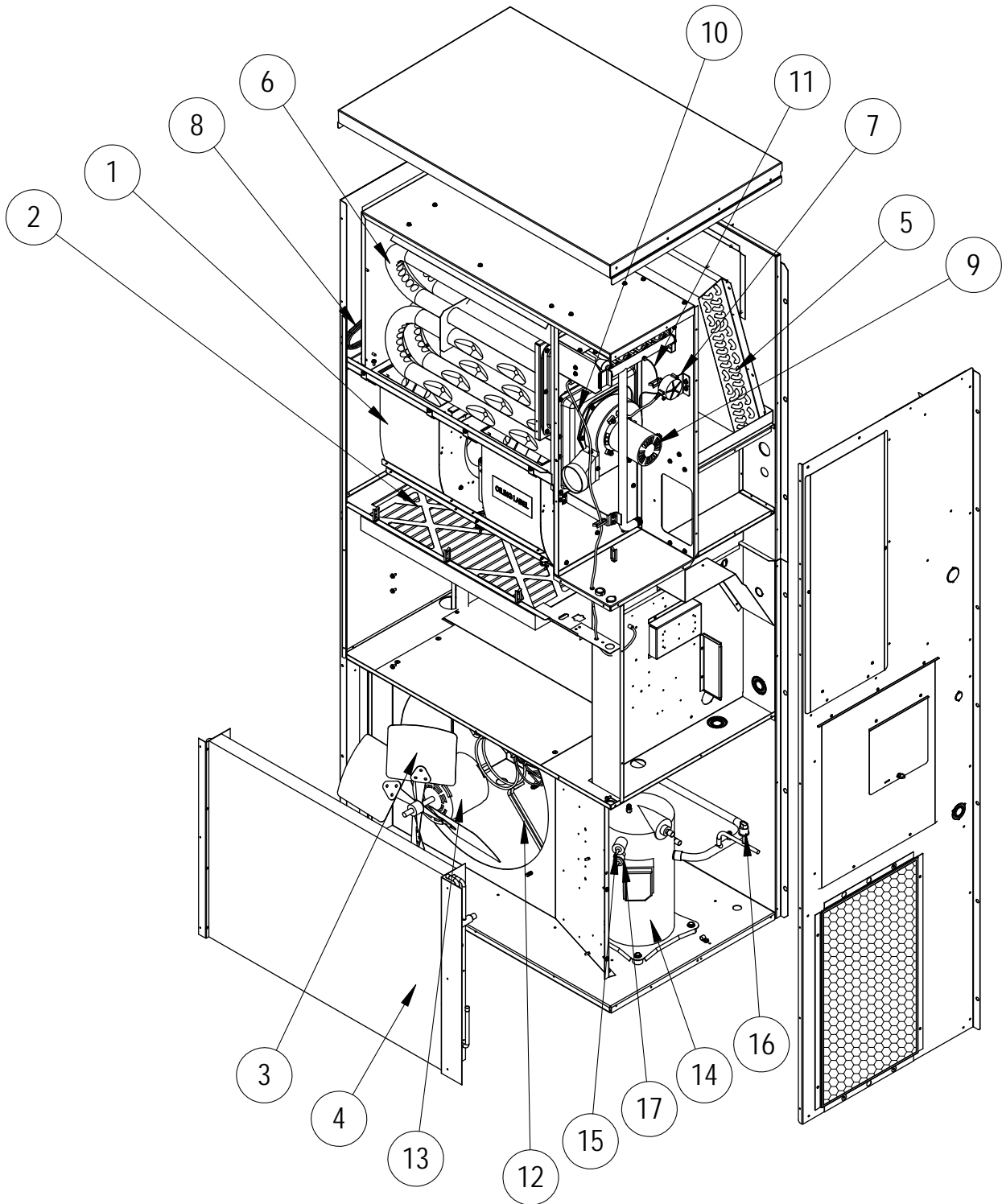

SEXP-677

This drawing to be used for reference for pages 7 and 8

## FUNCTIONAL COMPONENTS – STANDARD

Drawing No.	Part No.	Description	W24G4-A	W24G4-B	W24G4-C	W30G4-A	W30G4-B	W30G4-C	W36G4-A	W36G4-B	W36G4-C
1	S900-375-001	Complete Blower Assembly 230/208	X	X							
1	S900-376-001	Complete Blower Assembly 460V			X						
1	S900-375-002	Complete Blower Assembly 230/208				X	X				
1	S900-376-002	Complete Blower Assembly 460V						X			
1	S900-375-003	Complete Blower Assembly 230/208							X	X	
1	S900-376-003	Complete Blower Assembly 460V									X
2	7004-040	20 x 25 x 2 MERV 8 Filter (Standard)	X	X	X	X	X	X	X	X	X
2	7003-042	20 x 25 x 1 AF Filter	O	O	O	O	O	O	O	O	O
2	7004-071	20 x 25 x 2 MERV 13 Filter	O	O	O	O	O	O	O	O	O
3	S5151-045	Fan Blade	X	X	X	X	X	X	X	X	X
4	5051-066BX	Condenser Coil	X	X	X	X	X	X			
4	5054-066BX	Coated Condenser Coil	O	O	O	O	O	O			
4	5051-234BX	Condenser Coil							X	X	X
4	5054-234BX	Coated Condenser Coil							O	O	O
5	917-0154BX	Evaporator Coil	X	X	X						
5	917-0155BX	Coated Evaporator Coil	O	O	O						
5	917-0156BX	Evaporator Coil				X	X	X	X	X	X
5	917-0157BX	Coated Evaporator Coil				O	O	O	O	O	O
6	Heat Exch.	See Burner Components Diagram	X	X	X	X	X	X	X	X	X
7	8406-103	.55" + .05" Pressure Switch	X	X	X	X	X	X	X	X	X
8	S800-0400	Distributor/Orifice	X	X	X						
8	S800-0401	Distributor/Orifice				X	X	X			
8	S800-0492	Distributor/Orifice							X	X	X
9	8109-014	Induced Draft Blower 230V w/Transition	X	X		X	X		X	X	
9	8109-015	Induced Draft Blower 460V w/Transition			X			X			X
10	8600-011	Suppression Ignition Cable	X	X	X	X	X	X	X	X	X
11	3000-1615	Wire Assembly	X	X	X	X	X	X	X	X	X
12	8200-001	Fan Motor Mount	X	X	X	X	X	X	X	X	X
13	S8103-029	Motor 230/208V	X	X		X	X		X	X	
13	S8103-030	Motor 460V			X			X			X
14	8000-434	Compressor ZP21K5E-PFV-130	X								
14	8000-435	Compressor ZP21K5E-TF5-130		X							
14	8000-436	Compressor ZP21K5E-TFD-130			X						
14	8000-277	Compressor ZP25K5E-PFV-130				X					
14	8000-365	Compressor ZP25K5E-TF5-130					X				
14	8000-366	Compressor ZP25K5E-TFD-130						X			
14	8000-278	Compressor ZP31K5E-PFV-130							X		
14	8000-283	Compressor ZP31K5E-TF5-130								X	
14	8000-342	Compressor ZP31K5E-TFD-130									X
15	8406-142	High Pressure Switch	X	X	X	X	X	X	X	X	X
16	8406-140	Low Pressure Switch	X	X	X	X	X	X	X	X	X
17	S8406-105	Low Ambient Control (Part of CMA-46 LAC Kit)	O	O	O	O	O	O	O	O	O
NS	CMA-46	Complete Low Ambient Kit	O	O	O	O	O	O	O	O	O
NS	8408-048	Freeze Stat (Part of CMA-46 LAC Kit)	O	O	O	O	O	O	O	O	O
NS	6031-009	Coremax Valve Core	X	X	X	X	X	X	X	X	X

NS - Not Shown  
X - Standard  
O - Optional



# FUNCTIONAL COMPONENTS – DEHUMIDIFICATION

Drawing No.	Part No.	Description	W24G4DA	W24G4DB	W24G4DC	W30G4DA	W30G4DB	W30G4DC	W36G4DA	W36G4DB	W36G4DC
1	S900-375-001	Complete Blower Assembly 230/208	X	X							
1	S900-376-001	Complete Blower Assembly 460V			X						
1	S900-375-002	Complete Blower Assembly 230/208				X	X				
1	S900-376-002	Complete Blower Assembly 460V						X			
1	S900-375-003	Complete Blower Assembly 230/208							X	X	
1	S900-376-003	Complete Blower Assembly 460V									X
2	7004-040	20 x 25 x 2 MERV 8 Filter (Standard)	X	X	X	X	X	X	X	X	X
2	7003-042	20 x 25 x 1 AF Filter	O	O	O	O	O	O	O	O	O
2	7004-071	20 x 25 x 2 MERV 13 Filter	O	O	O	O	O	O	O	O	O
3	S5151-045	Fan Blade	X	X	X	X	X	X	X	X	X
4	5051-066BX	Condenser Coil	X	X	X	X	X	X			
4	5054-066BX	Coated Condenser Coil	O	O	O	O	O	O			
4	5051-234BX	Condenser Coil							X	X	X
4	5054-234BX	Coated Condenser Coil							O	O	O
5	917-0154BX	Evaporator and Reheat Assembly	X	X	X						
5	917-0155BX	Coated Evaporator and Reheat Assembly	O	O	O						
5	917-0156BX	Evaporator and Reheat Assembly				X	X	X	X	X	X
5	917-0157BX	Coated Evaporator and Reheat Assembly				O	O	O	O	O	O
6	Heat Exch.	See Burner Components Diagram	X	X	X	X	X	X	X	X	X
7	8406-103	.55" + .05" Pressure Switch	X	X	X	X	X	X	X	X	X
8	5625-007	Distributor	X	X	X						
8	5625-008	Distributor				X	X	X	X	X	X
9	8109-014	Induced Draft Blower 230V w/Transition	X	X		X	X		X	X	
9	8109-015	Induced Draft Blower 460V w/Transition			X			X			X
10	8600-011	Suppression Ignition Cable	X	X	X	X	X	X	X	X	X
11	3000-1615	Wire Assembly	X	X	X	X	X	X	X	X	X
12	8200-001	Fan Motor Mount	X	X	X	X	X	X	X	X	X
13	S8103-029	Motor 230/208V	X	X		X	X		X	X	
13	S8103-030	Motor 460V			X			X			X
14	8000-434	Compressor ZP21K5E-PFV-130	X								
14	8000-435	Compressor ZP21K5E-TF5-130		X							
14	8000-436	Compressor ZP21K5E-TFD-130			X						
14	8000-277	Compressor ZP25K5E-PFV-130				X					
14	8000-365	Compressor ZP25K5E-TF5-130					X				
14	8000-366	Compressor ZP25K5E-TFD-130						X			
14	8000-278	Compressor ZP31K5E-PFV-130							X		
14	8000-283	Compressor ZP31K5E-TF5-130								X	
14	8000-342	Compressor ZP31K5E-TFD-130									X
15	8406-142	High Pressure Switch	X	X	X	X	X	X	X	X	X
16	8406-140	Low Pressure Switch	X	X	X	X	X	X	X	X	X
17	S8406-105	Low Ambient Control (Part of CMA-45 LAC Kit)	O	O	O	O	O	O	O	O	O
NS	CMA-45	Low Ambient Control (Optional)	O	O	O	O	O	O	O	O	O
NS	5651-219	Check Valve	X	X	X	X	X	X	X	X	X
NS	5650-044	Molded Plug	X	X	X	X	X	X	X	X	X
NS	5650-051	Three Way Valve with Solenoid	X	X	X	X	X	X	X	X	X
NS	5651S245	Expansion Valve	X	X	X	X	X	X	X	X	X
NS	5651-246	EEV Cable and Stator	X	X	X	X	X	X	X	X	X
NS	8408-056	EEV Thermistor	X	X	X	X	X	X	X	X	X
NS	8406-158	Transducer	X	X	X	X	X	X	X	X	X
NS	5201-021	Filter Drier	X	X	X	X	X	X	X	X	X
NS	8408-048	Freeze Thermostat	X	X	X	X	X	X	X	X	X
NS	5650-046	Solenoid Coil 24V	X	X	X	X	X	X	X	X	X
NS	6031-009	Coremax Valve Core	X	X	X	X	X	X	X	X	X

*This page intentionally left blank*

# BURNER COMPONENTS – STANDARD & DEHUMIDIFICATION

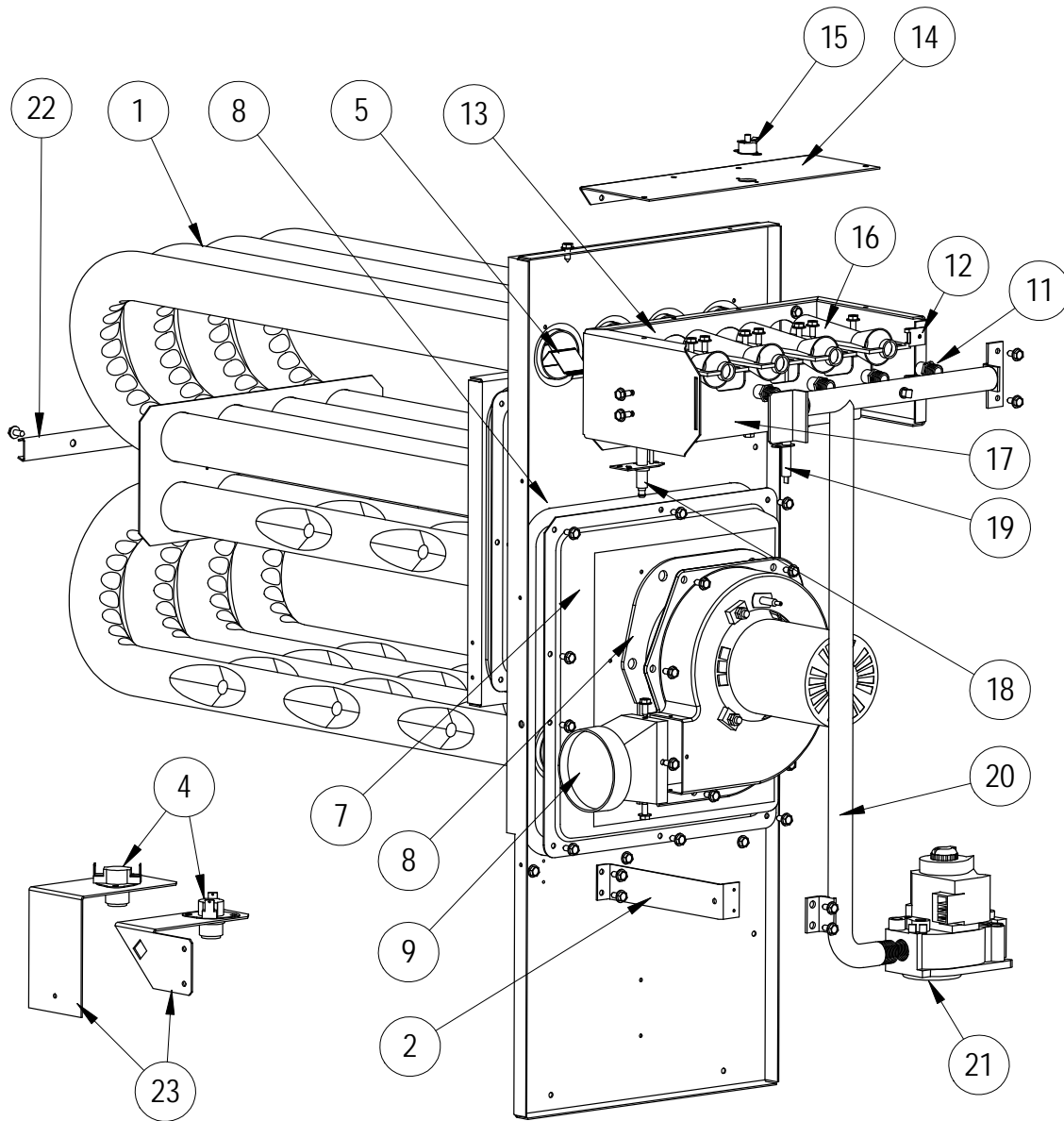

SEXP-678 A

This drawing to be used for reference for pages 11, 12 and 13

## BURNER COMPONENTS – STANDARD & DEHUMIDIFICATION

Drawing No.	Part No.	Description	W24G4**XA	W24G4**NA	W24G4**XB	W24G4**NB	W24G4**XC	W24G4**NC
1	S171-303	Heat Exchanger Assembly (2 Burner)	X	X				
1	S171-305	Heat Exchanger Assembly (3 Burner)			X	X		
1	S171-307	Heat Exchanger Assembly (4 Burner)					X	X
2	113-268	Manifold Bracket	X	X	X	X	X	X
4	8402-180	Limit Control L140-30	X	X				
4	8402-178	Limit Control L120-30			X	X		
4	8402-177	Limit Control L115-30					X	X
5	9010-099	NOx Screen		2		3		4
7	168-142	Collector Box	X	X				
7	168-143	Collector Box			X	X		
7	168-144	Collector Box					X	X
8	1921-043	Gasket Set	X	X	X	X	X	X
9	5809-013	3" Cast Inducer Transition	X	X	X	X	X	X
11	9010-082	Orifice 2.30mm (.0885 diameter)	2	2	3	3	4	4
11	9010-087	Orifice 2.20mm (10% derate)	2	2	3	3	4	4
12	1012-314	U Clip Fastener	2	2	2	2	2	2
13	163-050	Burner Box	X	X				
13	163-049	Burner Box			X	X		
13	163-052	Burner Box					X	X
14	141-493	Flame Rollout Support	X	X	X	X		
14	141-494	Flame Rollout Support					X	X
15	8402-124	Flame Rollout Switch L270	X	X	X	X	X	X
16	9010-078	In-Shot Burner 2.5 x 4.5	2	2	3	3	4	4
17	163-048	Burner Support	X	X				
17	163-041	Burner Support			X	X		
17	163-043	Burner Support					X	X
18	8554-024	DSI Spark Igniter	X	X	X	X	X	X
19	8554-025	Flame Sensor	X	X	X	X	X	X
20	5818-053	2-Hole Gas Manifold - 1/2"	X	X				
20	5818-054	3-Hole Gas Manifold - 1/2"			X	X		
20	5818-055	4-Hole Gas Manifold - 1/2"					X	X
21	5651-160	Natural Gas Valve 1/2 x 1/2	X	X	X	X	X	X
22	168-140	Tube Brace 2 Burner	X	X				
22	168-135	Tube Brace 3 Burner			X	X		
22	168-134	Tube Brace 4 Burner					X	X
23	112-355	Limit Bracket	X	X				
23	112-475	Limit Bracket			X	X	X	X
NS	S400-0203	Orifice Parts Bag 2 Tube 45K	X	X				
NS	S400-0204	Orifice Parts Bag 3 Tube 67.5K			X	X		
NS	S400-0205	Orifice Parts Bag 4 Tube 90K					X	X
NS	8600-011	Ignition Cable	X	X	X	X	X	X

NS – Not Shown

# BURNER COMPONENTS – STANDARD & DEHUMIDIFICATION

Drawing No.	Part No.	Description	W30G4**XA	W30G4**NA	W30G4**XB	W30G4**NB	W30G4**XC	W30G4**NC
1	S171-303	Heat Exchanger Assembly (2 Burner)	X	X				
1	S171-305	Heat Exchanger Assembly (3 Burner)			X	X		
1	S171-307	Heat Exchanger Assembly (4 Burner)					X	X
2	113-268	Manifold Bracket	X	X	X	X	X	X
4	8402-180	Limit Control L140-30	X	X				
4	8402-178	Limit Control L120-30			X	X		
4	8402-177	Limit Control L115-30					X	X
5	9010-099	NOx Screen		2		3		4
7	168-142	Collector Box	X	X				
7	168-143	Collector Box			X	X		
7	168-144	Collector Box					X	X
8	1921-043	Gasket Set	X	X	X	X	X	X
9	5809-013	3" Cast Inducer Transition	X	X	X	X	X	X
11	9010-082	Orifice 2.30mm (.0885 diameter)	2	2	3	3	4	4
11	9010-087	Orifice 2.20mm (10% derate)	2	2	3	3	4	4
12	1012-314	U Clip Fastener	2	2	2	2	2	2
13	163-050	Burner Box	X	X				
13	163-049	Burner Box			X	X		
13	163-052	Burner Box					X	X
14	141-493	Flame Rollout Support	X	X	X	X		
14	141-494	Flame Rollout Support					X	X
15	8402-124	Flame Rollout Switch L270	X	X	X	X	X	X
16	9010-078	In-Shot Burner 2.5 x 4.5	2	2	3	3	4	4
17	163-048	Burner Support	X	X				
17	163-041	Burner Support			X	X		
17	163-043	Burner Support					X	X
18	8554-024	DSI Spark Igniter	X	X	X	X	X	X
19	8554-025	Flame Sensor	X	X	X	X	X	X
20	5818-053	2-Hole Gas Manifold - 1/2"	X	X				
20	5818-054	3-Hole Gas Manifold - 1/2"			X	X		
20	5818-055	4-Hole Gas Manifold - 1/2"					X	X
21	5651-160	Natural Gas Valve 1/2 x 1/2	X	X	X	X	X	X
22	168-140	Tube Brace 2 Burner	X	X				
22	168-135	Tube Brace 3 Burner			X	X		
22	168-134	Tube Brace 4 Burner					X	X
23	112-355	Limit Bracket	X	X				
23	112-475	Limit Bracket			X	X	X	X
NS	S400-0203	Orifice Parts Bag 2 Tube 45K	X	X				
NS	S400-0204	Orifice Parts Bag 3 Tube 67.5K			X	X		
NS	S400-0205	Orifice Parts Bag 4 Tube 90K					X	X
NS	8600-011	Ignition Cable	X	X	X	X	X	X

NS – Not Shown

Refer to drawing on page 10

## BURNER COMPONENTS – STANDARD & DEHUMIDIFICATION

Drawing No.	Part No.	Description	W36G4**XA	W36G4**NA	W36G4**XB	W36G4**NB	W36G4**XC	W36G4**NC
1	S171-303	Heat Exchanger Assembly (2 Burner)	X	X				
1	S171-305	Heat Exchanger Assembly (3 Burner)			X	X		
1	S171-307	Heat Exchanger Assembly (4 Burner)					X	X
2	113-268	Manifold Bracket	X	X	X	X	X	X
4	8402-180	Limit Control L140-30	X	X				
4	8402-178	Limit Control L120-30			X	X		
4	8402-177	Limit Control L115-30					X	X
5	9010-099	NOx Screen		2		3		4
7	168-142	Collector Box	X	X				
7	168-143	Collector Box			X	X		
7	168-144	Collector Box					X	X
8	1921-043	Gasket Set	X	X	X	X	X	X
9	5809-013	3" Cast Inducer Transition	X	X	X	X	X	X
11	9010-082	Orifice 2.30mm (.0885 diameter)	2	2	3	3	4	4
11	9010-087	Orifice 2.20mm (10% derate)	2	2	3	3	4	4
12	1012-314	U Clip Fastener	2	2	2	2	2	2
13	163-050	Burner Box	X	X				
13	163-049	Burner Box			X	X		
13	163-052	Burner Box					X	X
14	141-493	Flame Rollout Support	X	X	X	X		
14	141-494	Flame Rollout Support					X	X
15	8402-124	Flame Rollout Switch L270	X	X	X	X	X	X
16	9010-078	In-Shot Burner 2.5 x 4.5	2	2	3	3	4	4
17	163-048	Burner Support	X	X				
17	163-041	Burner Support			X	X		
17	163-043	Burner Support					X	X
18	8554-024	DSI Spark Igniter	X	X	X	X	X	X
19	8554-025	Flame Sensor	X	X	X	X	X	X
20	5818-053	2-Hole Gas Manifold - 1/2"	X	X				
20	5818-054	3-Hole Gas Manifold - 1/2"			X	X		
20	5818-055	4-Hole Gas Manifold - 1/2"					X	X
21	5651-160	Natural Gas Valve 1/2 x 1/2	X	X	X	X	X	X
22	168-140	Tube Brace 2 Burner	X	X				
22	168-135	Tube Brace 3 Burner			X	X		
22	168-134	Tube Brace 4 Burner					X	X
23	112-355	Limit Bracket	X	X				
23	112-475	Limit Bracket			X	X	X	X
NS	S400-0203	Orifice Parts Bag 2 Tube 45K	X	X				
NS	S400-0204	Orifice Parts Bag 3 Tube 67.5K			X	X		
NS	S400-0205	Orifice Parts Bag 4 Tube 90K					X	X
NS	8600-011	Ignition Cable	X	X	X	X	X	X

NS – Not Shown

Refer to drawing on page 10

# CONTROL PANEL - STANDARD & DEHUMIDIFICATION

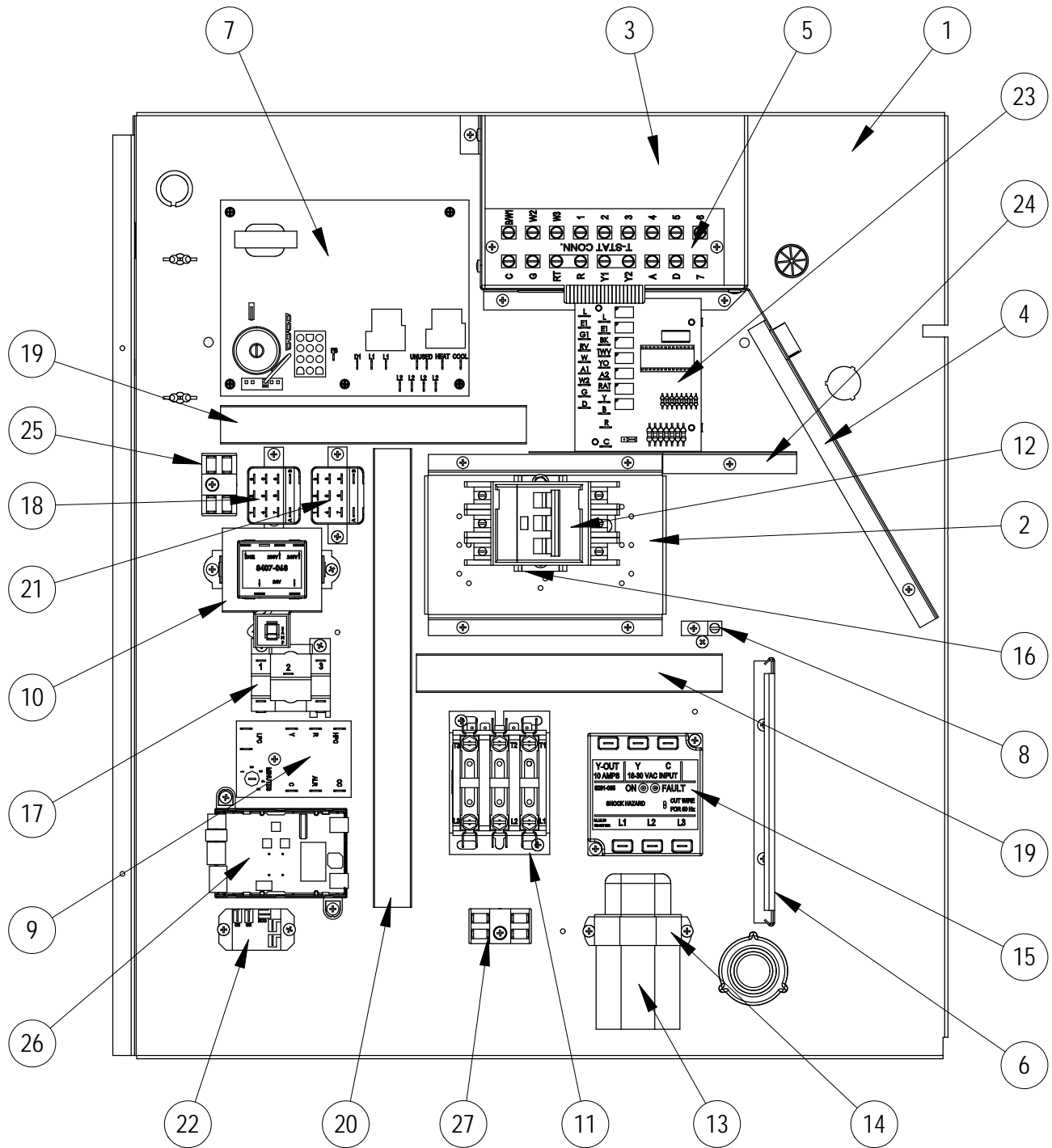

SEXP-1013

This drawing to be used for reference for pages 15 and 16

## CONTROL PANEL - STANDARD

Drawing No.	Part No.	Description	W24G4-A	W24G4-B	W24G4-C	W30G4-A	W30G4-B	W30G4-C	W36G4-A	W36G4-B	W36G4-C
1	517-408	Control Panel	X	X	X	X	X	X	X	X	X
2	113-269	Circuit Breaker Mounting Bracket	X	X		X	X		X	X	
2	127-590	460V Disconnect Base			X			X			X
3	117-410	Low Voltage Box	X	X	X	X	X	X	X	X	X
4	117-409	Low Voltage Partition	X	X	X	X	X	X	X	X	X
5	8607-062	Terminal Strip	X	X	X	X	X	X	X	X	X
6	135-130	Wire Shield	X	X	X	X	X	X	X	X	X
7	5651-159	Integrated Furnace Control	X	X	X	X	X	X	X	X	X
8	8611-006	Terminal	X	X	X	X	X	X	X	X	X
9	S8201-164	Compressor Control Module	X	X	X	X	X	X	X	X	X
10	8407-068	Transformer	X	X		X	X		X	X	
10	8407-069	Transformer			X			X			X
11	S8401-002	Compressor Contactor		X	X		X	X		X	X
11	S8401-025	Compressor Contactor	X			X			X		
12	S8615-095	600V 40A Toggle Disconnect			X			X			X
12	S8615-096	600V Switch Cover Plate			X			X			X
12	S8615-056	230V 15A Circuit Breaker		X							
12	S8615-017	230V 25A Circuit Breaker				X				X	
12	S8615-037	230V 30A Circuit Breaker	X			X					
12	S8615-038	230V 35A Circuit Breaker							X		
13	S8552-002	Outdoor Fan Capacitor		X	X		X	X		X	X
13	S8552-050	Outdoor Fan Capacitor	X			X					
13	S8552-052	Outdoor Fan Capacitor							X		
14	8550-003	Capacitor Bracket		X	X		X	X		X	X
14	8550-008	Capacitor Bracket	X			X			X		
15	8201-126	Phase Monitor		X	X		X	X		X	X
16	8611-209	DIN Rail		X	X		X	X		X	X
16	8611-210	DIN Rail	X			X			X		
17	8201-032	Inducer Relay	X	X	X	X	X	X	X	X	X
18	8201-159	Blower Relay	X	X	X	X	X	X	X	X	X
19	8611-140-0800	Cable Duct - 8" x 1" Wide	2	2	2	2	2	2	2	2	2
20	8611-140-1200	Cable Duct - 12" x 1" Wide	X	X	X	X	X	X	X	X	X
24	135-266	Wire Shield	X	X	X	X	X	X	X	X	X
25	8607-017	Terminal Block	X	X	X	X	X	X	X	X	X
27	8607-017	Terminal Block - LAC Kit	O	O	O	O	O	O	O	O	O
NS	4085-177	Wiring Diagram	X			X			X		
NS	4085-277	Wiring Diagram		X			X			X	
NS	4085-400	Wiring Diagram			X			X			X
NS	3000-1616	Blower Power Plug	X	X	X	X	X	X	X	X	X
NS	3000-1617	Blower Speed Plug	X	X	X	X	X	X	X	X	X
NS	3000-1224	Compressor Plug/Harness	X			X			X		
NS	3000-1231	Compressor Plug/Harness		X	X		X	X		X	X
NS	3003-075	Control Panel Wire Harness		X	X		X	X		X	X
NS	3003-076	Control Panel Wire Harness	X			X			X		
NS	3000-1618	Integrated Furnace Control Plug	X	X	X	X	X	X	X	X	X

NS - Not Shown

X - Standard

O - Optional



# CONTROL PANEL – DEHUMIDIFICATION

Drawing No.	Part No.	Description	W24G4DA	W24G4DB	W24G4DC	W30G4DA	W30G4DB	W30G4DC	W36G4DA	W36G4DB	W36G4DC
1	517-408	Control Panel	X	X	X	X	X	X	X	X	X
2	113-269	Circuit Breaker Mounting Bracket	X	X		X	X		X	X	
2	127-590	460V Disconnect Base			X			X			X
3	117-410	Low Voltage Box	X	X	X	X	X	X	X	X	X
4	117-409	Low Voltage Partition	X	X	X	X	X	X	X	X	X
5	8607-062	Terminal Strip	X	X	X	X	X	X	X	X	X
6	135-130	Wire Shield	X	X	X	X	X	X	X	X	X
7	5651-159	Integrated Furnace Control	X	X	X	X	X	X	X	X	X
8	8611-006	Terminal	X	X	X	X	X	X	X	X	X
9	S8201-164	Compressor Control Module	X	X	X	X	X	X	X	X	X
10	8407-068	Transformer	X	X		X	X		X	X	
10	8407-069	Transformer			X			X			X
11	S8401-002	Compressor Contactor		X	X		X	X		X	X
11	S8401-025	Compressor Contactor	X			X			X		
12	S8615-095	600V 40A Toggle Disconnect			X			X			X
12	S8615-096	600V Switch Cover Plate			X			X			X
12	S8615-056	230V 15A Circuit Breaker		X							
12	S8615-017	230V 25A Circuit Breaker				X				X	
12	S8615-037	230V 30A Circuit Breaker	X			X					
12	S8615-038	230V 35A Circuit Breaker						X			
13	S8552-002	Outdoor Fan Capacitor		X	X		X	X		X	X
13	S8552-050	Outdoor Fan Capacitor	X			X					
13	S8552-052	Outdoor Fan Capacitor						X			
14	8550-003	Capacitor Bracket		X	X		X	X		X	X
14	8550-008	Capacitor Bracket	X			X			X		
15	8201-126	Phase Monitor		X	X		X	X		X	X
16	8611-209	DIN Rail		X	X		X	X		X	X
16	8611-210	DIN Rail	X			X			X		
17	8201-032	Inducer Relay	X	X	X	X	X	X	X	X	X
18	8201-159	Blower Relay	X	X	X	X	X	X	X	X	X
19	8611-140-0800	Cable Duct - 8" x 1" Wide	2	2	2	2	2	2	2	2	2
20	8611-140-1200	Cable Duct - 12" x 1" Wide	X	X	X	X	X	X	X	X	X
21	8201-159	Lockout Relay	X	X	X	X	X	X	X	X	X
22	8201-130	Dehumidification Control Relay	X	X	X	X	X	X	X	X	X
23	8201-113	Dehumidification Logic Board	X	X	X	X	X	X	X	X	X
24	135-266	Wire Shield	X	X	X	X	X	X	X	X	X
25	8607-017	Terminal Block	X	X	X	X	X	X	X	X	X
26	8301-079-0001	EEV Control Board (see page 8 for other EEV parts)	X	X	X	X	X	X	X	X	X
27	8607-017	Terminal Block - LAC Kit	0	0	0	0	0	0	0	0	0
NS	4085-173	Wiring Diagram	X			X			X		
NS	4085-273	Wiring Diagram		X			X			X	
NS	4085-396	Wiring Diagram			X			X			X
NS	3000-1616	Blower Power Plug	X	X	X	X	X	X	X	X	X
NS	3000-1617	Blower Speed Plug	X	X	X	X	X	X	X	X	X
NS	3000-1224	Compressor Plug/Harness	X			X			X		
NS	3000-1231	Compressor Plug/Harness		X	X		X	X		X	X
NS	3003-070	Control Panel Wire Harness		X	X		X	X		X	X
NS	3003-074	Control Panel Wire Harness	X			X			X		
NS	3000-1618	Integrated Furnace Control Plug	X	X	X	X	X	X	X	X	X

NS - Not Shown

X - Standard

O - Optional

# BLOWER ASSEMBLY

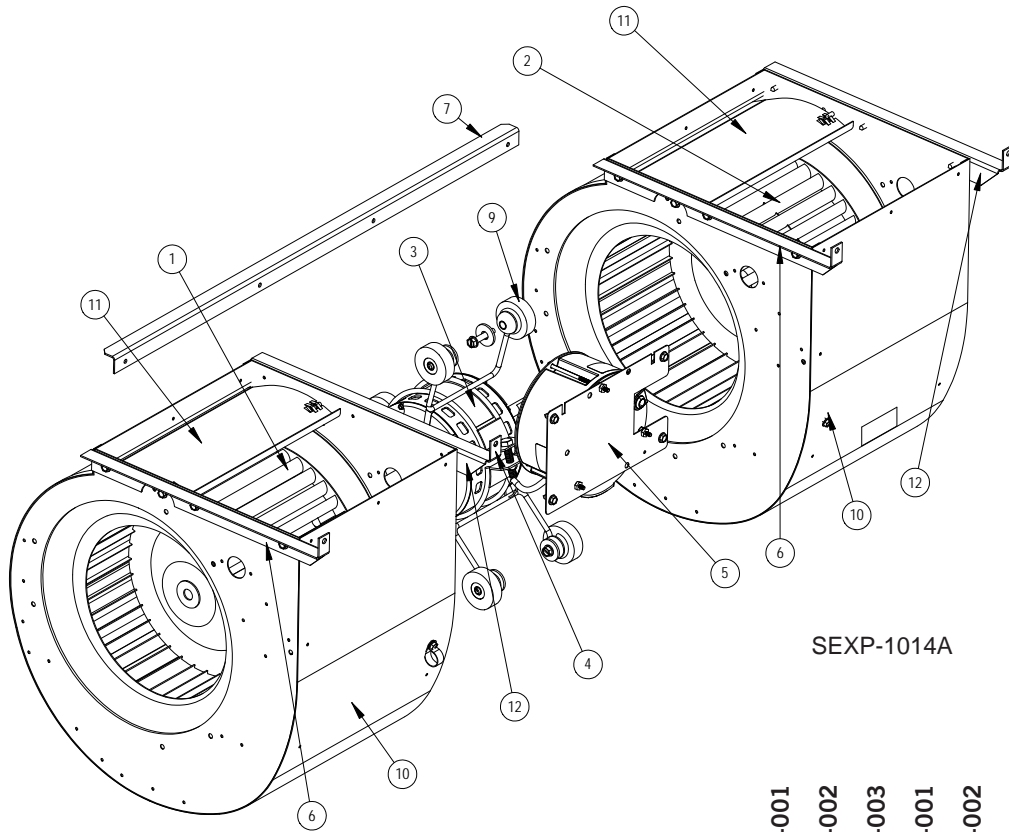

SEXP-1014A

Drawing No.	Part No.	Description	900-375-001	900-375-002	900-375-003	900-376-001	900-376-002	900-376-003
1	5152-096	Blower Wheel	X	X	X	X	X	X
2	5152-072	Blower Wheel	X	X	X	X	X	X
3	S8106-068-0186	Blower Motor & Control (230/208V)	X					
3	S8106-068-0187	Blower Motor & Control (230/208V)		X				
3	S8106-068-0188	Blower Motor & Control (230/208V)			X			
3	S8106-069-0192	Blower Motor & Control (460V)				X		
3	S8106-069-0193	Blower Motor & Control (460V)					X	
3	S8106-069-0194	Blower Motor & Control (460V)						X
3	C8106-068-0186	Programmed Control Only (230/208V)	X					
3	C8106-068-0187	Programmed Control Only (230/208V)		X				
3	C8106-068-0188	Programmed Control Only (230/208V)			X			
3	C8106-069-0192	Programmed Control Only (460V)				X		
3	C8106-069-0193	Programmed Control Only (460V)					X	
3	C8106-069-0194	Programmed Control Only (460V)						X
4	8200-040	Motor Mount	X	X	X	X	X	X
5	112-775	Motor Control Bracket	X	X	X	X	X	X
6	105Y1075	Angle – Left	2	2	2	2	2	2
7	105-1109	Angle – Back	X	X	X	X	X	X
9	5451-011	Grommett	6	6	6	6	6	6
10	151-117	Blower Housing	2	2	2	2	2	2
11	144-167	Diffuser	2	2	2	2	2	2
12	105X1075	Angle – Right	2	2	2	2	2	2





## WG SERIES TROUBLESHOOTING PROCEDURES

### **WARNING**

Before servicing this gas appliance, turn off all electric power supply and close all gas valves to the appliance. Failure to do so could result in fire, personal injury, or death.

TURN ON 230 VOLT AC POWER SUPPLY — TURN UP THERMOSTAT — 0.20 AMP HEAT ANTICIPATOR SETTING

SYMPTOM	POSSIBLE CAUSES	HOW TO CHECK AND/OR CORRECT
Induced draft blower does not operate.	Thermostat or thermostat wiring defective.	Remove thermostat wires from the furnace control board. Jumper terminals "R" and "W" on furnace control board. If inducer blower starts: A. Check thermostat wiring B. Change thermostat
	No main power supply, 24 volt power supply, or blown 3A fuse on furnace control.	Remove low voltage wires from transformer. Check for 24 volts AC coming out of transformer. If there is no voltage present: A. Check for 230 volts AC at terminals "L1" and "L2". If there is not 230 volts, check power supply or breaker. B. If there is 230 volts present at terminals "L1" and "L2", but there is not 24 volts present at the transformer leads, the transformer must be replaced. C. Replace 3A fuse on furnace control.
	Furnace control board defective.	If 24 volts is not present at Pin 1 and Pin 2 at the plug on the board and 230 volts is present at "L1" and "L2" and there is no power at "L2" and "D1", the board must be replaced.
Direct spark igniter does not spark.	Pressure switch is defective. Spark igniter assembly is defective. Ignition cable is defective. Furnace control is defective. Debris shorting out spark igniter.	With thermostat calling for heat, jumper the two pressure terminals. If igniter starts sparking, check for: A. Blockage in vent terminal B. Excessive dirt, lint, soot or scale on induced draft blower wheel. C. Check for poor connection, leaks, or blockage in the tubing connecting the pressure switch to the inducer. D. Pressure switch is defective.
Igniter sparks but there is no ignition.	No gas supply. Gas orifice obstructions. Low gas supply pressure. Defective ignition control.	Check for obstructions in main gas orifices Make sure all gas cocks are open and gas valve is in the "ON" position. Make sure that the minimum gas supply pressure, stated on the rating plate, is available to the gas valve.

Troubleshooting Procedures continued on Page 2.

*NOTE: Before replacing any component of this unit, verify that all wiring is correct with the wiring diagram.*

## Troubleshooting Procedures

(continued from Page 1)

SYMPTOM	POSSIBLE CAUSES	HOW TO CHECK AND/OR CORRECT
Main burner lights but the comfort air blower does not run.	Defective furnace control board, blower motor or capacitor.	Once burner lights, wait approximately 30 seconds and check for supply voltage AC between "L2" and "HEAT" terminals on furnace control board. If there is <b>no</b> voltage present, replace board. If voltage is present, check capacitor. If capacitor is good, replace blower motor.
Main burner cycles on and off or stays off and the induced draft blower and comfort air blower do not shut off.	Limit switches opening due to high outlet air temperature or defective control.	Jumper terminals on both sides of each limit switch. If this corrects cycling problem check: A. Limit setting on control should be at setting specified on the furnace rating plate. B. Clogged or dirty filters. C. Static pressure on supply side not to exceed that specified on the rating plate. D. Inadequate return air sizing. E. Defective limit control.
	Flame roll-out switch is open due to flame rolling out of combustion area caused by inadequate combustion air through the heat exchanger. The flame roll-out switch is located on top of the burner box assembly.	The flame roll-out switch is a manual reset control. Check to make sure the switch has been reset. Check for blockage in the vent terminal and/or the induced draft blower.  If blockage is present, remove obstruction.  Also check for blockage in the heat exchanger flue passageways. Remove any blockage.
	Pressure switch defective or malfunctioning.	Jumper out terminals on the pressure switch, if this corrects cycling problem check: A. Blockage in vent terminal. B. Excessive dirt, lint, soot or scale on induced draft blower. C. Defective pressure switch.
Comfort air blower does not stop.	Defective furnace control board.	If comfort air blower continues to run for more than 2 - 3 minutes after the call for heat has been satisfied, the furnace control board must be replaced.

### DIAGNOSTIC INDICATOR

A red LED is provided to indicate system faults as follows:

- Steady ON - Control okay in standby, call for heat, cool or fan modes
- Steady OFF - Internal control fault or no power. Also check 3A fuse on control.
- 1 flash - Lockout due to failed ignition or flame dropouts
- 2 flashes - Pressure switch open with inducer on
- 3 flashes - Pressure switch is closed with inducer off
- 4 flashes - Limit switch is open
- 5 flashes - Flame detected with gas valve closed
- 6 flashes - Compressor output delayed from short cycle/staging timer

The flash rate is 0.25 seconds on, 0.25 seconds off with 2.0 seconds pause between flash codes.

# WG SERIES

## UNDERSTANDING THE PRESSURE CONTROL

All WG models are equipped with a pressure sensing device. This device performs the two important functions shown below:

- Prevents main burner operation in the event of inadequate combustion air of a failed combustion air blower.
- Prevents main burner operation in the event the vent terminal should become obstructed.

This pressure device is commonly referred to as a pressure switch. The switch consists of normally open contacts which close when a specified amount of negative pressure (vacuum) is applied to the mechanical side of the device. The switch will remain closed as long as the required amount of negative pressure is present. If that negative pressure or vacuum reduces below the required amount, the switch contacts will open, thus shutting down the unit. The source of this negative pressure is created within the combustion air blower housing, and is transferred from the blower housing to the pressure switch through a 3/16" diameter silicone tube. If any unusual restriction is applied any point downstream of the combustion air blower, the negative pressure or vacuum within the blower housing will decrease, opening the switch contacts and shutting down the unit.

All WG series use the same pressure switch. The pressure switch contacts close at negative .65" W.C. and open at negative .55" W.C. for units installed from 0 – 6,000 feet elevation above sea level. If unit is installed above 6,001 feet the unit must be converted using a high altitude pressure switch, Bard kit number, 8620-189. The pressure switch included with this kit is designed for the contacts to close at a negative .52" W.C. and open at .42" W.C.

## PRESSURE MEASUREMENT WITHIN THE SYSTEM

To measure the pressure within the system, a pressure gauge with a range of 0 to 1 inch water column in .02 inch W.C. increments is required.

This gauge is to be connected to the silicone tubing between the pressure switch and the combustion air blower. Refer to Figure 1 on Page 4.

A small plastic or copper tee and a 3/16" diameter piece of hose is used to connect the gauge between the combustion air blower and the pressure switch.

With the gauge in place, start the unit and monitor the pressure within the system. The ignition device will be activated once the pressure exceeds the switch contact close points specified above. As the furnace warms up, the pressure will drop about .2" W.C.

The pressure within the system should not drop to or below the switch contacts open point shown above. If the switch contacts open above or below the specified set point  $\pm .05$ " W.C., the switch must be replaced.

If the pressure within the system drops to the switch open set points, the following items should be checked:

1. Any obstruction in the vent terminal
2. Any excessive lint, dirt or scale on the combustion air blower wheel
3. Any obstructions or moisture inside the 3/16" silicone tubing

FIGURE 1

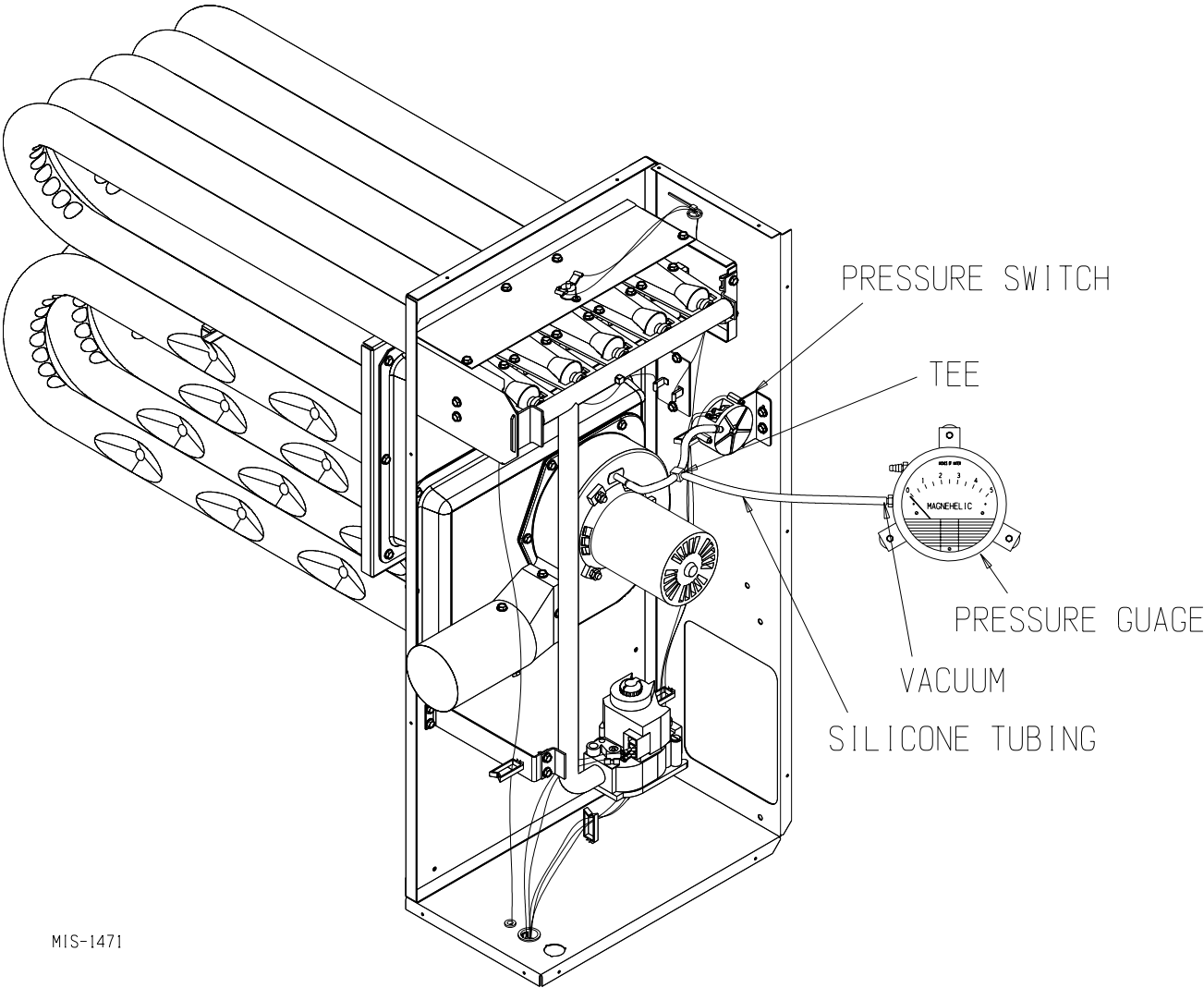

MIS-1471





---

# SERVICING PROCEDURE

---

## R-410A LEAK TEST EVACUATION CHARGING

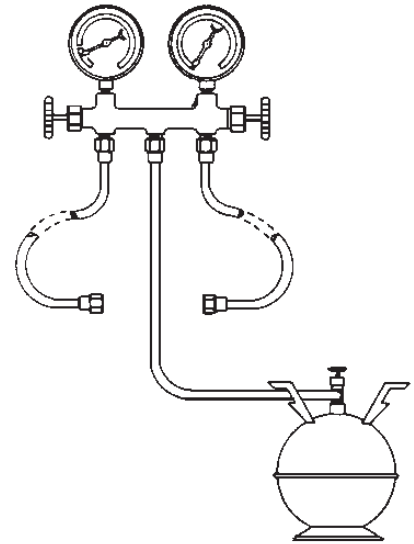

**Climate Control Solutions**

Bard Manufacturing Company, Inc.  
Bryan, Ohio 43506  
*Since 1914...Moving ahead, just as planned.*

Manual No.: 2100-479  
Supersedes: NEW  
File: Volume I, Tab 1  
Date: 03-08-07

# CONTENTS

---

## General

Recovery Equipment Rated for R-410A.....	3
Leak Detectors.....	3
Gauge Manifold.....	3
Attaching Gauge Manifold.....	3
Attaching Manifold Hose to Schrader Valve.....	4
Leak Test.....	4
Evacuation .....	4 & 5
Charging .....	5
Preliminary Charging Steps .....	5
Charging the System by Weight .....	5

## Troubleshooting the Mechanical System

<b>Air Conditioning &amp; Heat Pump - Cooling</b> .....	9
Low Suction—Low Head Pressure .....	9
High Suction—Low Head Pressure .....	9
Low Suction—High Head Pressure .....	9
High Suction—High Head Pressure.....	9
<b>Heat Pump - Heating</b> .....	9
Low Suction—Low Head Pressure .....	9
High Suction—Low Head Pressure .....	9
Low Suction—High Head Pressure .....	9
High Suction—High Head Pressure.....	9

## Figures

Figure 1: Typical AC System Cooling Cycle.....	6
Figure 2: Typical HP System Cooling Cycle .....	7
Figure 3: Heating Cycle .....	8

## Charts

Troubleshooting Chart for Air Conditioners.....	10
Troubleshooting Chart for Air-to-Air Heat Pumps....	11

# GENERAL

---



## WARNING

The oils used with R-410A refrigerant are hygroscopic and absorb water from the atmosphere readily. Do not leave systems open to the atmosphere for more than 5 minutes. If the system has been open for more than 5 minutes, change the filter dryer immediately before evacuation. Then recharge the system to the factory specified charge.

### Recovery equipment rated for R-410A refrigerant

R-410A has an ozone depletion potential of zero, but must be reclaimed due to its global warming potential.

The gauge manifold set is specially designed to withstand the higher pressure associated with R-410A. Manifold sets are required to range up to 800 psig on the high side and 250 psig on the low side with a 250 psig low side retard.

All hoses must have a service rating of 800 psig. (This information will be indicated on the hoses.)

Vacuum Pump and micron gauge must be used when evacuating a system to 500 microns.

### Leak Detectors

An electronic leak detector capable of detecting HFC refrigerant can be used with R-410A refrigerant.

## GAUGE MANIFOLD



## WARNING

Gauge manifold must be suitable for use with R-410A refrigerant and POE oils.

A necessary instrument in checking and serving air conditioning and heat pump equipment is the gauge manifold. Its purpose is to determine the operating refrigerant pressures in order for the serviceman to analyze the condition of the system.

The valving on the manifold is so arranged that when the valves are closed (front-seated) the center port on the manifold is closed to the gauges and gauge ports. With the valves in the closed position, the gauge ports are still open to the gauges, permitting the gauges to register system pressures. Opening either valve opens the center port to that side of the manifold and system.

## ATTACHING GAUGE MANIFOLD

For leak testing, purging, checking charge, charging liquid or evacuating, connect high pressure side of gauge manifold to Schrader valve on liquid or discharge line. Connect suction side of gauge manifold to Schrader valve on suction line. On heat pumps the suction line is between compressor and reversing valve.

## ATTACHING MANIFOLD HOSE TO SCHRADER VALVE



### WARNING

As a safety measure, it is wise to detach refrigerant hoses at the lowest pressure readings on the system. To do this:

- A. Put high pressure hose "B" on first. (Unit should not be running.)
- B. Put low pressure hose "A" on second. (Unit should be running.)

1. Remove cap from valve.
2. Make sure gauge manifold valves are closed.
3. If hose does not have an unseating pin, a number 395 Superior or equivalent unseating coupler must be used.
4. Make sure coupler is lined up straight with Schrader valve. Screw coupler on to valve.
5. Open gauge manifold valve slightly and purge air from hose with refrigerant.
6. Read the suction pressure on compound gauge and heat pressure on pressure gauge.
7. To remove, push end of hose tight against end of Schrader valve and hold in place while quickly unscrewing coupler nut from Schrader valve.
8. Remove coupler from Schrader valve. Replace caps on valve.

### Leak Test

1. Remove gauge port cap from suction and liquid service valve ports and attach manifold gauge hoses. Connect an upright R-410A drum to center port of gauge manifold. Open refrigerant drum valve and manifold high pressure gauge valve to pressurize system to a positive pressure with refrigerant vapor. Pressurize the complete system with dry nitrogen, or CO2 until the pressure reaches 200 psig. **Do not** exceed 250 psig.
2. Close manifold high pressure gauge valve. Check all soldered joints, including those on the evaporator coil with an Electronic Leak Detector suitable for use with HFC refrigerants or R-410A. If a leak is found which requires soldering, pressure in the system must be bled off since it is impossible to solder with unit pressurized. Be sure all leaks are located and marked before bleeding pressure from system.

3. Close drum valve and disconnect from center port. Release nitrogen or CO2 into the atmosphere through suction line of gauge manifold.
4. Correct any leaks and recheck. When leaks, if any, have been repaired, system is ready to be evacuated and charged. Relieve all pressure from the system down to 0 psig.
5. Change the filter dryer. When leaks, if any, have been repaired, system is ready to be evacuated and charged. Relieve all pressure from the system down to 0 psig.

### EVACUATION

#### Evacuation

An evacuation to 500 microns is usually sufficient to remove moisture from a system using R-22 and mineral oil lubricant. A 500 micron evacuation, however, will not separate moisture from Polyol Ester oil (POE) in R-410A systems.

In addition to a 500 micron evacuation, the liquid line filter dryer (R-410A compatible) must be replaced any time the system is open. When removing a filter dryer from a system, do not use a torch; use a tubing cutter to avoid releasing moisture back into the system.

Older R-22 leak detectors, as well as halide torch leak detectors, will not detect leaks in R-410A systems. Never use air and R-410A to leak check, as the mixture may become flammable at pressures above 1 atmosphere. A system can be safely leak-checked by using nitrogen or a trace gas of R-410A and nitrogen.

**Remember:** *Always use a pressure regulator with nitrogen and a safety valve down stream - set at no more than 150 psig.*

1. Evacuate system to less than 500 microns, using a good vacuum pump and an accurate high vacuum gauge. Operate the pump below 500 microns for 60 minutes and then close valve to the vacuum pump. Allow the system to stand for 30 additional minutes to be sure a 500 micron vacuum or less is maintained.



### WARNING

At no time use the compressor to evacuate the system or any part of it.

2. Disconnect charging line at vacuum pump and connect to refrigerant supply. Crack the cylinder valve and purge charging line at center on manifold. Then close cylinder valve.
3. The system is now ready for the correct operating charge of Refrigerant R-410A.

### R-410A System Charging

Even though R-410A has a very small fractionation potential, it cannot be ignored completely when charging. To avoid fractionation, charging of an air conditioner or heat pump system incorporating R-410A **shall be done with “liquid”** to maintain optimum system performance. To insure that the proper blend composition is charged into the system, it is important that liquid only be removed from the charging cylinder. Some cylinders supplied by manufacturers have dip tubes, which allow liquid refrigerant to be removed from the cylinder when it is in the upright position. Cylinders without dip tubes have to be tipped upside down in order for liquid to be removed. The Service Technician must differentiate between which type of charging cylinder they are using to avoid removing vapor refrigerant instead of liquid refrigerant to avoid fractionation and for safety concerns.

Connect the gauge manifold to the high and low side. Allow liquid to enter the high side only. The high side will hold 80-100% of the total charge. When liquid stops flowing, close high side port. The remainder of the charge will be added to the low side. Keep in mind two issues: first, never start the compressor with less than 55 psig of suction pressure. Secondly, make sure the liquid is throttled, thus vaporized into the low side of the system to avoid compressor damage. A throttling valve can be used to insure that liquid is converted to vapor prior to entering the system. Proper manipulation (restricting) of the manifold gauge set can also act as a throttling device to insure liquid is not entering the compressor.

### CHARGING

1. **Single Package Units**—Refer to the unit serial plate for the full operating charge.

### PRELIMINARY CHARGING STEPS

If the system has been open to the atmosphere, the filter dryer should be replaced and then evacuated. Then proceed as follows:

1. Attach a drum of proper, clean refrigerant to the center port of the charging manifold with one of the charging hoses.
2. Attach a second charging hose to the suction gauge (low pressure) side of the gauge manifold.
3. Remove the cap from the suction line valve.
4. Loosely attach the suction gauge hose to the line valve. Open the valve on the refrigerant drum and the suction valve on the charging manifold slightly to purge the air from the manifold and hoses before tightening the fitting.
5. Attach the third hose to the high pressure side of the manifold and the liquid line valve. Repeat steps 3 and 4 above.

### CHARGING THE SYSTEM BY WEIGHT

1. Connect manifold as instructed.
2. Place refrigerant drum upright on scale and determine exact weight of the refrigerant and cylinder.
3. With manifold suction valve closed and manifold discharge valve open, open refrigerant cylinder liquid valve and allow pressure in system to balance with pressure of cylinder or 80% of charge is in the unit - whichever comes first.
4. When there is approximately an 80% charge, front seat (close) the discharge manifold valve and let the system stabilize for about five minutes.
5. Start compressor by setting thermostat.
6. Finish charging with liquid by cracking the suction valve. Open the manifold low pressure valve to allow refrigerant to flow into the system. Throttle the manifold valve to keep pressure about 100 psig for R-410A.
7. When the correct weight of refrigerant has been added to the unit, close refrigerant cylinder valve and allow unit to run for 30 minutes. Refer to Start-Up Procedure and Check List for further start-up details.
8. Front seat gauge manifold valves, disconnect charging and gauge hoses and replace all valve caps.

**FIGURE 1  
TYPICAL AIR CONDITIONING SYSTEM COOLING CYCLE**

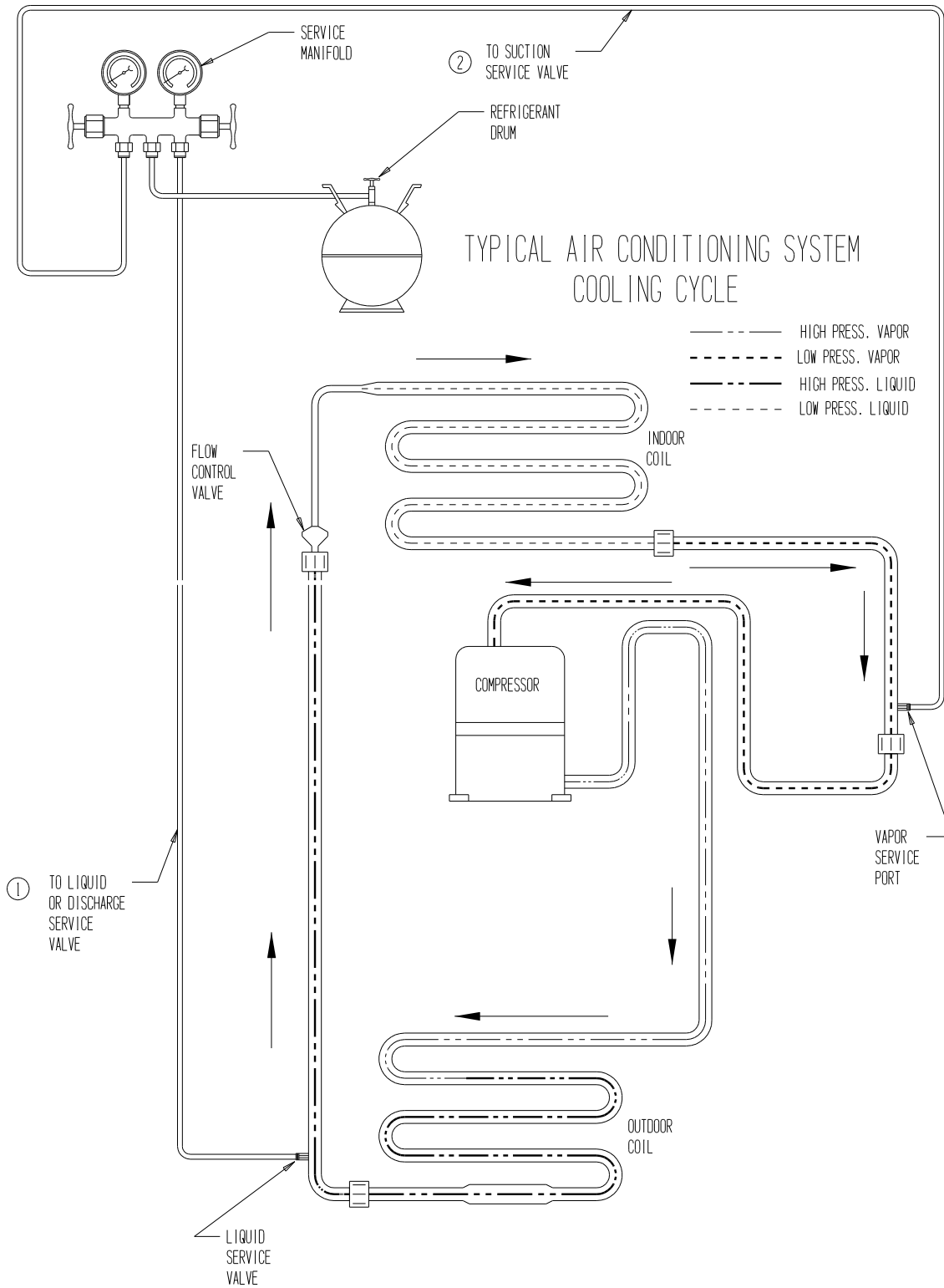

**MIS-369**

**FIGURE 2**  
**TYPICAL HEAT PUMP SYSTEM COOLING CYCLE**

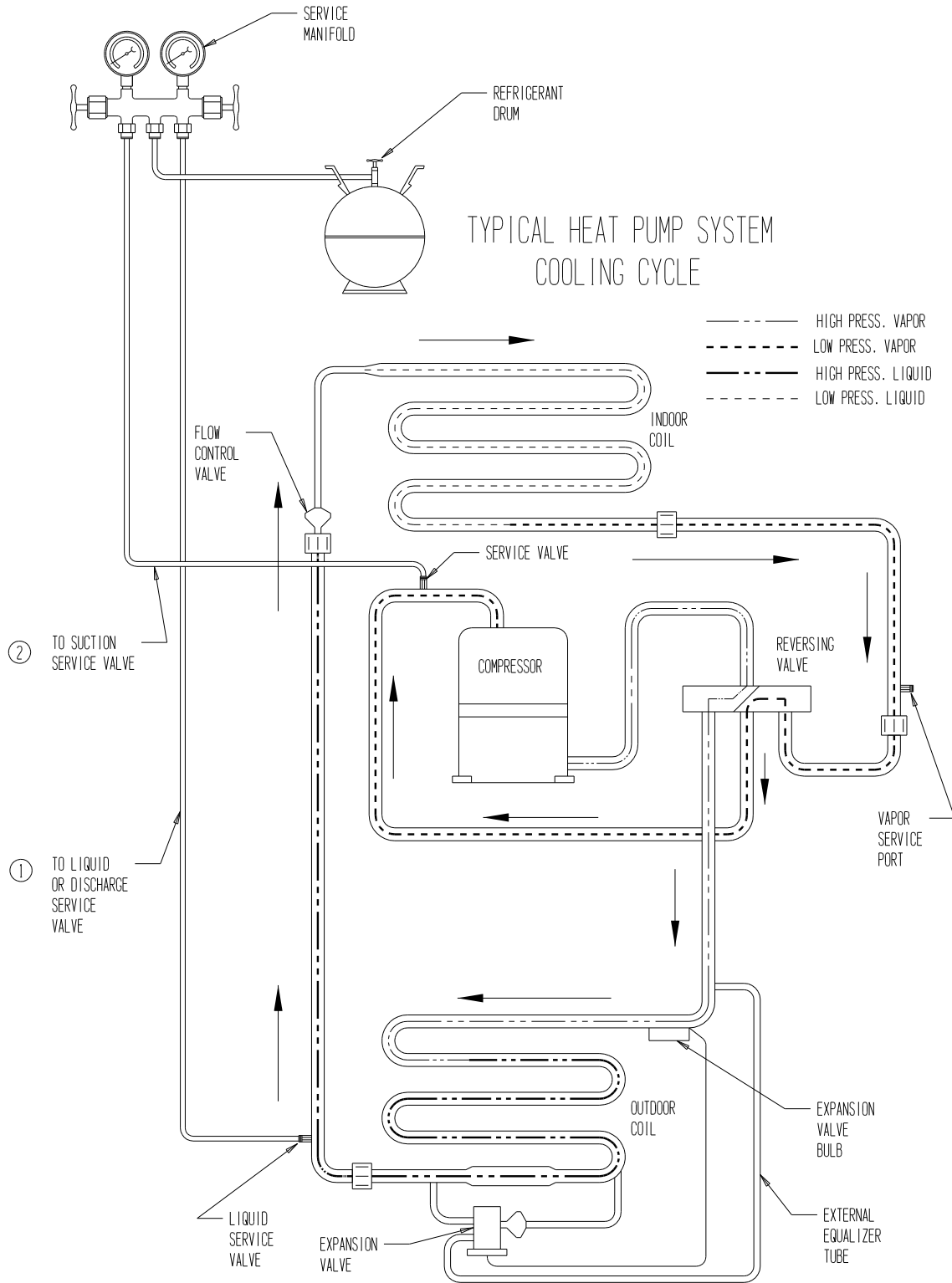

**MIS-368**

# WARNING

To speed refrigerant flow, it may be necessary to place refrigerant drum in a pan of warm water (not greater than 130°F). Remember to either consider the total weight of the pan of water or remove the drum for weighing frequently to keep track of the charging process.

**FIGURE 3  
HEATING CYCLE**

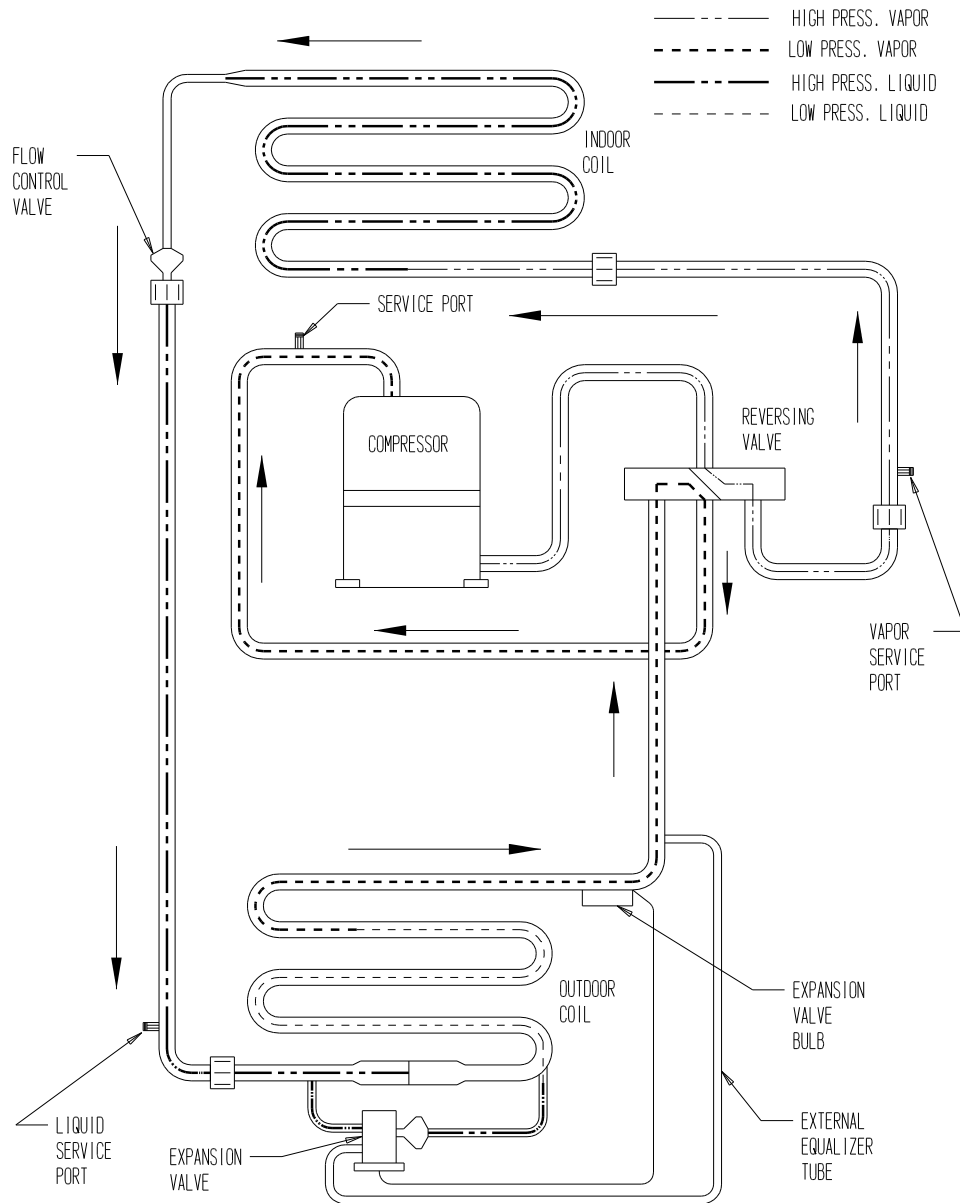

MIS-289



# **TROUBLESHOOTING THE MECHANICAL SYSTEM**

---

## **AIR CONDITIONING AND HEAT PUMP — COOLING**

### **LOW SUCTION—LOW HEAD PRESSURE**

1. Restricted airflow over indoor coil.
2. Defective indoor fan motor.
3. Low indoor temperature
4. Iced indoor coil.
5. Restricted liquid line, dryer, metering device, etc.
6. Low charge.
7. Low ambient entering air temperature. (Low entering water temperature to water coil.Ⓢ)

### **HIGH SUCTION—LOW HEAD PRESSURE**

1. Defective or broken valves.
2. IPRV valve open.
3. Defective reversing valve.

### **LOW SUCTION—HIGH HEAD PRESSURE**

1. Partial restriction and then overcharged.

### **HIGH SUCTION—HIGH HEAD PRESSURE**

1. High entering outdoor air temperature. (High entering water temperature.Ⓢ)
2. Low airflow outdoor coil. (Low water flow.Ⓢ)
3. Overcharged.
4. Air in system.
5. Restricted outdoor coil. (Restricted water coil.Ⓢ)
6. High indoor air temperature.

Ⓢ Water source heat pump.

## **HEAT PUMP — HEATING**

### **LOW SUCTION—LOW HEAD PRESSURE**

1. Restricted airflow through outdoor coil. (Restricted water flow through water coil.Ⓢ)
2. Defective outdoor motor. (Defective water pump.Ⓢ)
3. Low outdoor air temperature. (Low water temperature.Ⓢ)
4. Frozen outdoor coil. (Frozen water coil.Ⓢ)
5. Restricted liquid line, dryer, metering device, etc.
6. Low charge.
7. Low indoor air temperature.

### **HIGH SUCTION—LOW HEAD PRESSURE**

1. Defective or broken valves.
2. IPR valve open.
3. Defective reversing valve.

### **LOW SUCTION—HIGH HEAD PRESSURE**

1. Partial restriction and then overcharged.

### **HIGH SUCTION—HIGH HEAD PRESSURE**

1. High entering outdoor air temperature. (High entering water temperature.Ⓢ)
2. Low indoor airflow.
3. Overcharged.
4. Air in system.
5. Restricted air coil.
6. High indoor air temperature.

Ⓢ Water source heat pump.







---

# Supplemental Instructions

---

## S8201-169 Compressor Control Module

(Replaces 8201-088, 8201-148, 8201-157,  
8201-162, 8201-164, 8620-244)

---

### Features

Delay-on-Make Timer  
Short Cycle Protection/Delay-on-Break  
Low Pressure Detection  
High Pressure Detection  
HPC and LPC Status LEDs  
Test Mode  
Brownout Protection with Adjustment

### Delay-on-Make Timer

A delay-on-make timer is included to be able to delay startup of the compressor. This is desired when more than one unit is on a structure so that all of the units do not start at the same time which could happen after a power loss or building shutdown. The delay-on-make time period is 2 minutes plus 10% of the delay-on-break time period. To ensure that all of the units do not start at the same time, adjust the delay-on-break timer on each unit to a slightly different delay time.

### Short Cycle Protection/Delay-on-Break

An anti-short cycle timer is included to prevent short cycling the compressor. This is adjustable from 30 seconds to 5 minutes via the adjustment knob. Once a compressor call is lost, the time period must expire before a new call will be initiated.

### Low Pressure Detection

Low pressure switch monitoring allows for a lockout condition in a situation where the switch is open. If the low pressure switch remains open for more than 2 minutes, the compressor control module (CCM) will

de-energize the compressor for the delay-on-break time. If the switch closes again, it will then restart the compressor. If the switch trips again during the same Y call, the compressor will be de-energized and the alarm terminal will be energized indicating an alarm. The blue LED will light and stay on until power is cycled to the control or a loss of voltage is present at Y terminal for more than ½ second.

### High Pressure Detection

High pressure switch monitoring allows for a lockout condition in a situation where the switch is open. If the high pressure switch opens, the CCM will de-energize the compressor. If the switch closes again, it will then restart the compressor after the delay-on-break setting has expired on the device. If the switch trips again during the same thermostat call, the compressor will be de-energized and the alarm terminal will be energized indicating an alarm. The red LED will light and stay on until power is cycled to the control or a loss of voltage is present at Y terminal for more than ½ second.

### Test Mode

By rapidly rotating the potentiometer (POT) clockwise (see Figure 1 on page 2), all timing functions will be removed for testing.

The conditions needed for the unit to enter test mode are as follows: POT must start at a time less than or equal to the 40 second mark. The POT must then be rapidly rotated to a position greater than or equal to the 280 second mark in less than ¼ second. Normal operation will resume after power is reset or after the unit has been in test mode for at least 5 minutes.



Climate Control Solutions

Bard Manufacturing Company, Inc.  
Bryan, Ohio 43506  
www.bardhvac.com

Manual: 7960-805A  
Supersedes: 7960-805  
Date: 2-13-20

## Brownout Protection with Adjustment

Brownout protection may be necessary if the utility power or generator power has inadequate power to prevent the voltage from dropping when the compressor starts. This is rare but can happen if the generator is undersized at the site or if the site is in a remote location far from the main power grid. Under normal circumstances, allowing the brownout to be ignored for a time period should not be needed. The 8201-169 is shipped in “O” do not ignore position.

If ignoring the brownout is needed because of the above conditions, three preset timers can be set by DIP switches in order to delay signaling a power brownout for a specific length of time after compressor contactor is energized. This allows the compressor a time period to start even if the voltage has dropped and allows the voltage to recover. This delay only happens when the CC terminal energizes. The delay can be set to 1, 5 or 10 seconds; time is not cumulative—only the longest setting will apply. If the voltage recovers during the brownout delay period, the compressor will

start. If the voltage doesn't recover during the time period, a brownout condition will be detected and the blue LED will flash. A flashing blue LED indicates that a brownout condition was sensed; the control will continue to flash the blue LED until the Y call has been satisfied. The compressor will try to start again after the delay-on-break timer expires.

If user chooses the “O” do not ignore position when the site has inadequate utility or generator power, this could lead to the compressor never starting. The control will see the brownout immediately and not start.

A common scenario and one that has been seen in the field is when a unit or units switches from utility power to generator power. With slower transfer switches, the time delay between the utility power and generator power didn't cause a problem. The units lost power, shut off and came back on line normally. With the introduction of almost instantaneous transfer switches, the millisecond long power glitch can be enough that the compressor will start to run backwards. In this scenario, the CCM will catch this and restart the units normally.

**FIGURE 1**  
**S8201-169 Compressor Control Module**

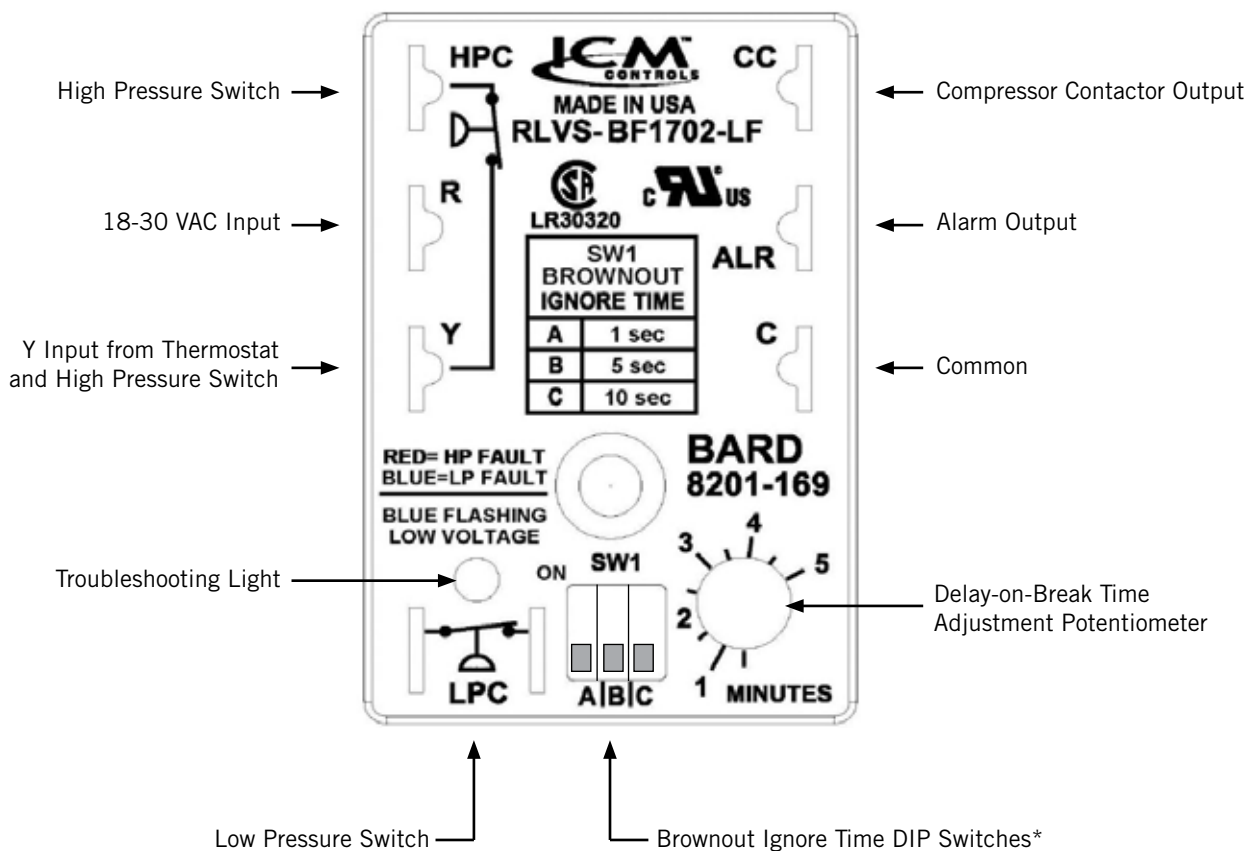

\* Turn on only one switch for that specific ignore time setting



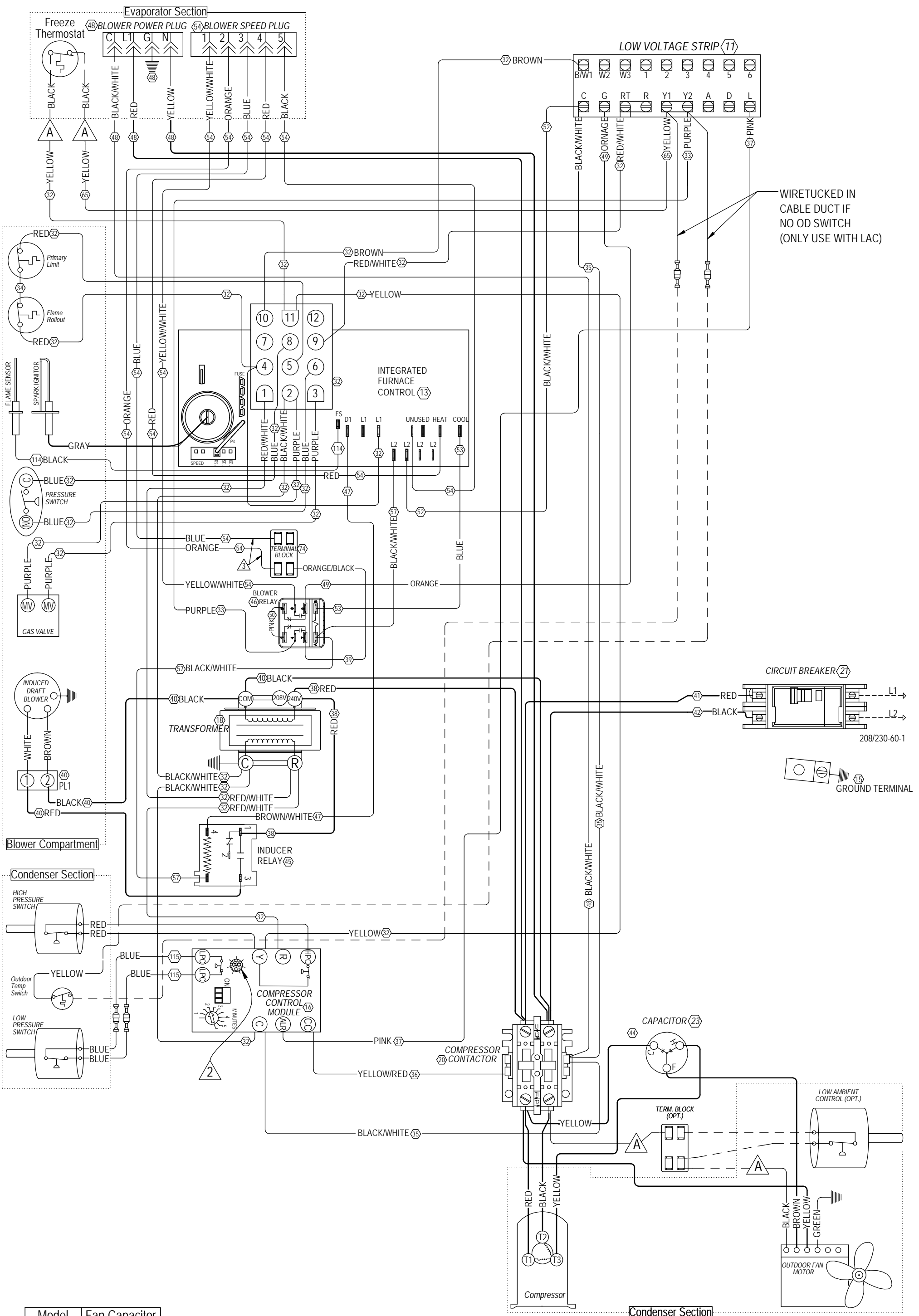

WIRETUCKED IN CABLE DUCT IF NO OD SWITCH (ONLY USE WITH LAC)

**Blower Compartment**

**Condenser Section**

**Condenser Section**

Model	Fan Capacitor
W48G*DC	15 / 370
W60G*DC	N/A

**3** TO CHANGE COOLING BLOWER SPEEDS, SWAP BLUE AND ORANGE WIRES

IF ANY ORIGINAL WIRES SUPPLIED WITH THE APPLIANCE MUST BE REPLACED, IT MUST BE REPLACED WITH WIRING MATERIAL HAVING A TEMPERATURE RATING OF AT LEAST 105° C EXCEPT THE IGNITION CABLE WHICH IS 250° C HIGH VOLTAGE CABLE

Same Letter Designated Wires Connect if Option Not Used

Wire Identification numbers for Bard use only. (99)

**2** RED - HIGH PRESSURE FAULT  
 BLUE - LOW PRESSURE FAULT  
 BLUE FLASH - LOW VOLTAGE

**1** DANGER  
 ELECTRICAL SHOCK HAZARD  
 DISCONNECT POWER BEFORE SERVICING.

**1** WARNING  
 USE COPPER CONDUCTORS  
 ONLY SUITABLE FOR AT LEAST 75° C.

	Factory	Field	Optional
High Voltage			
Low Voltage			





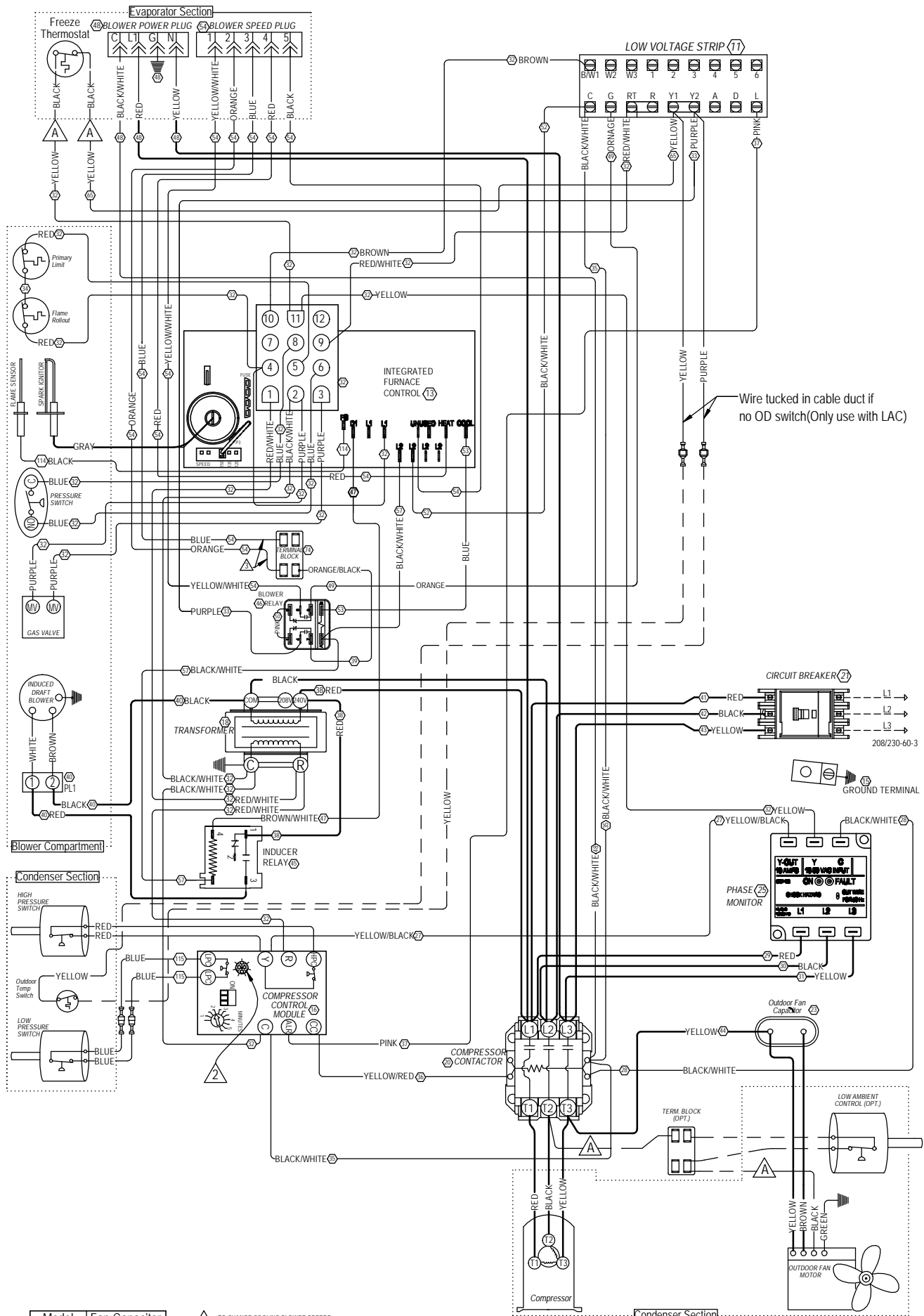

Model	Fan Capacitor
W48G*DC	15 / 370
W60G*DC	N/A

IF ANY ORIGINAL WIRES SUPPLIED WITH THE APPLIANCE MUST BE REPLACED. IT MUST BE REPLACED WITH WIRING MATERIAL HAVING A TEMPERATURE RATING OF AT LEAST 105° C EXCEPT THE IGNITION CABLE WHICH IS 250° C. HIGH VOLTAGE CABLE

3 TO CHANGE COOLING BLOWER SPEEDS, SWAP BLUE AND ORANGE WIRES

Same Letter Designated Wires Connect if Option Not Used

Wire Identification numbers for Bard use only (99)  
 RED - HIGH PRESSURE FAULT  
 BLUE - LOW PRESSURE FAULT  
 BLUE FLASH - LOW VOLTAGE

**DANGER**  
 ELECTRICAL SHOCK HAZARD  
 DISCONNECT POWER BEFORE SERVING

**WARNING**  
 USE COPPER CONDUCTORS ONLY SUITABLE FOR AT LEAST 75° C.

	Factory	Field	Optional
High Voltage			
Low Voltage			



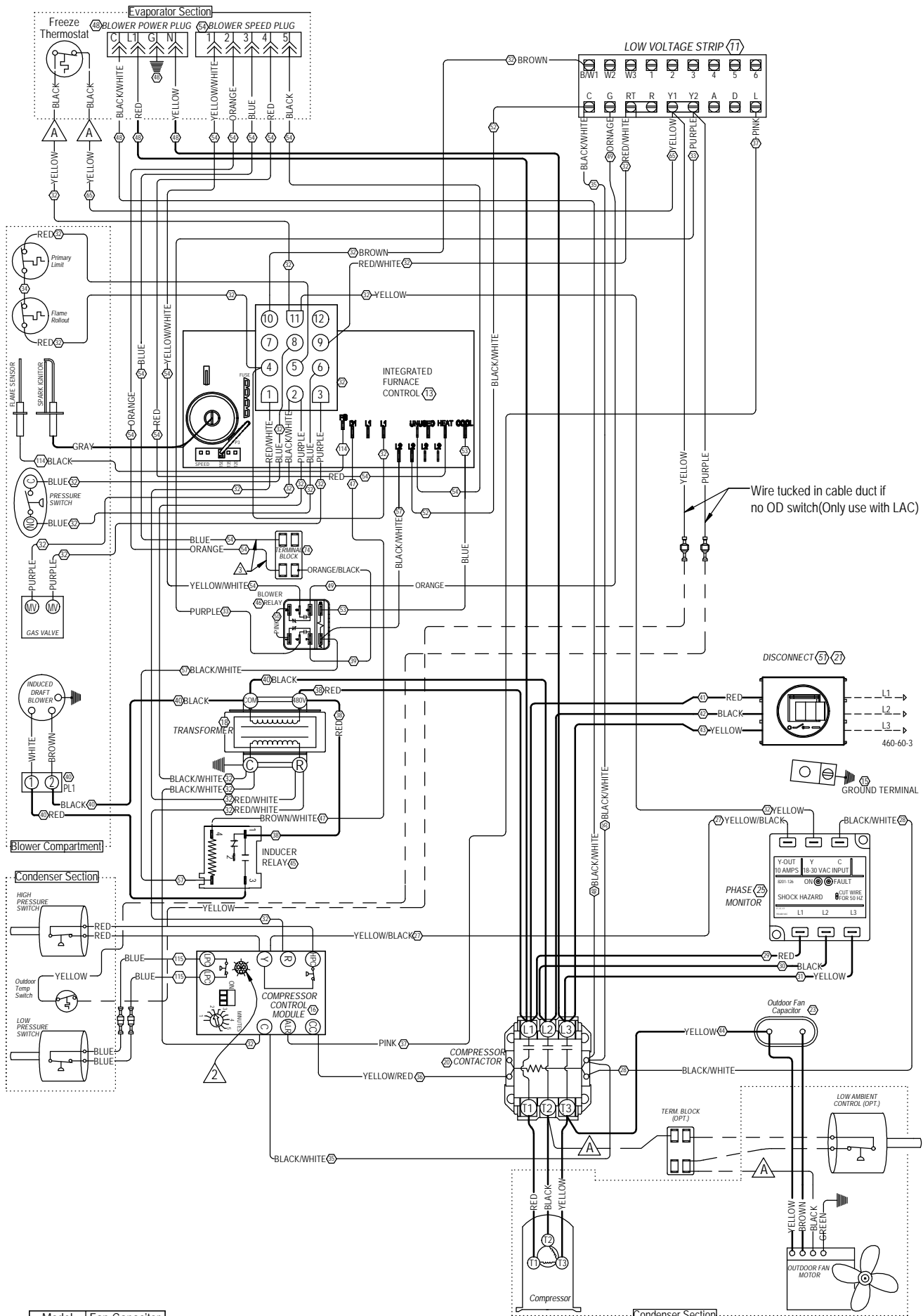

Model	Fan Capacitor
W48G*DC	15 / 370
W60G*DC	N/A

IF ANY ORIGINAL WIRES SUPPLIED WITH THE APPLIANCE MUST BE REPLACED. IT MUST BE REPLACED WITH WIRING MATERIAL HAVING A TEMPERATURE RATING OF AT LEAST 105° C EXCEPT THE IGNITION CABLE WHICH IS 250° C. HIGH VOLTAGE CABLE

**3** TO CHANGE COOLING BLOWER SPEEDS, SWAP BLUE AND ORANGE WIRES

**A** Same Letter Designated Wires Connect if Option Not Used

Wire Identification numbers for Bard use only (99)  
**RED** - HIGH PRESSURE FAULT  
**BLUE** - LOW PRESSURE FAULT  
**BLUE FLASH** - LOW VOLTAGE

**DANGER**  
 ELECTRICAL SHOCK HAZARD  
 DISCONNECT POWER BEFORE SERVICING

**WARNING**  
 USE COPPER CONDUCTORS  
 ONLY SUITABLE FOR AT LEAST 75° C.

	Factory	Field	Optional
High Voltage			
Low Voltage			

4085-400 E





# Limited Warranty

**For units applied within the United States, Puerto Rico,  
US Virgin Islands, Guam, Canada and Mexico**

## Limited Warranty To Original Purchaser:

Bard Manufacturing Company, Inc. Bryan, Ohio 43506 warrants to you, the original purchaser, that your Bard product will be free from defects in materials and workmanship when used under normal conditions from the installation date through the time periods outlined in the "Duration of Warranty" section (see reverse side).

## Proof Of Purchase:

You must be able to show us the date on which you purchased your product when you make a claim under this warranty. Your owner's registration card filed online at [www.wallmountwarranty.com](http://www.wallmountwarranty.com) or your contractor's invoice, bill of sale, or similar document is sufficient at time of warranty claim. If you can not show us the actual date of purchase, the time periods in this warranty will start on the date that we shipped your Bard product from our factory.

## What This Warranty Does Not Cover: (Also see Duration of Warranty on reverse side.)

This warranty does not cover defects or damage caused by:

1. Alterations not approved by us; improper installation (including over or under sizing), improper repairs, or servicing; or improper parts and accessories not supplied by us.
2. Misuse or failure to follow installation and operating instructions (including failure to perform preventative maintenance) or limitations on the rating plate. This includes failure to use low ambient controls on all applications requiring compressor operation in cooling mode below 60F outdoor ambient.
3. Any corrosion from operation in a corrosive atmosphere (examples: acids, halogenated hydrocarbons or environmental conditions).
4. Parts that must be replaced periodically (such as filters, oil nozzles, mist eliminators, ERV belts, pile seals, etc.).
5. Improper fuel or electrical supply (such as low voltage, voltage transients, power interruption, and units on generators with no brownout protection).
6. Accidents or other events beyond our reasonable control (such as storm, fire, or transportation damage).
7. Defects that happen after
  - (a) Anyone has tampered with the product.
  - (b) The product has been improperly serviced according to accepted trade practices;
  - (c) The product has been moved from its original place of installation; or,
  - (d) The product has been damaged by an event beyond Bard's control (See also No. 5 above).
8. Consequential damages (such as increased living expenses while the product is being repaired). Some states do not allow the exclusion or limitation of incidental or consequential damages, so the above limitation or exclusion may not apply to you.
9. This warranty has certain limitations for units installed on over-the-road trucks, vans and trailers. (See reverse side.)
10. Cost of service call at installation site to diagnose causes of trouble, labor to replace defective component or transportation costs for replacement parts.
11. This Limited Warranty does not apply to products installed or operated outside of the US, Puerto Rico, US Virgin Islands, Guam, Canada and Mexico. Units operated in coastal areas where the operating environment is exposed to airborne saline particles (typically 5 miles from coast line) must have corrosion protection or warranty claims will be declined on corrosion-based cabinet and part failures.
12. Bard does not endorse, approve or certify any online sales of its products through auction websites, online retailers, liquidators or any other method of online sales direct to consumers. Bard will not honor the factory warranty of any Bard equipment purchased over the Internet.

## Your Responsibilities:

You are responsible for -

1. Preventative maintenance of the product (such as cleaning and replacement of filters, nozzles and other consumable parts).
2. Insuring that the instruction manual is followed for care and use of your product.
3. Insuring that your product is installed by a competent, qualified contractor, following all local and national codes, and industry standards.

## What We Will Do About A Defect:

We will either repair or replace the defective part only. Replacement parts may be reconditioned parts. The warranty for the repaired or replaced part will last only for the remainder of the warranty period for the original part. For Heat Exchangers that are no longer available, we will give you credit equal to the then current retail price of an equivalent Heat Exchanger.

Defective parts and a properly completed Bard parts warranty form must be returned to a Bard distributor for submitting to Bard to be eligible for a warranty credit or replacement. Credits are issued to the Bard distributor.

We will not pay or be responsible for labor or defective/replacement part transportation costs or delays in repairing or failures to complete repairs caused by events beyond our reasonable control.

## What You Must Do

1. Tell your heating and air conditioning contractor as soon as you discover a problem and have the contractor make repairs.
2. Pay for all transportation, related service labor, diagnostic charges, refrigerant, refrigerant recovery and related items.

## Service

If your product requires service, you should contact the contractor who installed it or the contractor that has been providing the product's preventative maintenance and repair service. You may find the installing contractor's name on the product or in your Owner's packet. If you do not know who that is, you should contact a competent, qualified contractor to make the repairs. If in doubt, you should contact the nearest distributor that handles Bard products ([www.bardhvac.com](http://www.bardhvac.com)). Please note that contractors and distributors that handle Bard products are independent contractors and distributors, and therefore, are not under the direction of Bard Manufacturing Company, Inc.

## Only Warranty

This is the only warranty that we make. There are no other express warranties. All implied warranties are limited in duration to the duration of the applicable written warranty made above.

Some states do not allow limitations on how long an implied warranty lasts, so the above limitation or exclusion may not apply to you.

## Other Rights

This warranty gives you specific legal rights and you may have other rights which vary from state to state.

**BARD MANUFACTURING CO., INC. — BRYAN, OHIO 43506**  
*Dependable quality equipment . . . since 1914*

Form No. 7960-420  
Issued: 12/04/19  
Supersedes: 08/22/19

**Duration Of Warranty is limited to defects arising during the periods shown in the following table:**

Model Number Series: Includes all Models in each Series & which may have additional characters. (Example: W12-70A includes W36A w/additional characters.)	— Number of Years from Installation Date ① —			
	Compressor ⑤	Sealed System Components ②⑤⑦	All Other Functional Parts ③	Heat Exchangers
<b>AIR CONDITIONERS</b> W12A, W17A, W18A, W24A, W30A, W36A, W42A, W48A, W60A, W70A, W72A, W090A, W120A, W150, W180A, W17L, W18L, W24L, W30L, W36L, W42L, W48L, W60L, W70L, W72L, WA3S, WA4S, WA5S, WL3S, W4LS, WL5S, D25A, D28A, D35A, D36A, D42A, D48A, D60A, D25L, D28L, D35L, D36L, D42L, D48L, D60L, Q24A, Q30A, Q36A, Q42A, Q48A, Q60A, I30A, I36A, I42A, I60A	5	5	5	N/A
<b>AIR SOURCE HEAT PUMPS</b> W18H, W24H, W30H, W36H, W42H, W48H, W60H, C24H, C30H, C36H, C42H, C48H, C60H, T24H, T30H, T36H, T42H, T48H, T60H, T24S, T30S, T36S, T42S, T48S, T60S, Q24H, Q30H, Q36H, Q42H, Q43H, Q48H, Q60H, I30H, I36H, I42H, I48H, I60H, I36Z, I48Z, I60Z	5	5	5	N/A
<b>ENVIRONMENTAL CONTROL UNITS</b> W3RV, W4RV, W5RV, W6RV, W3LV, W4LV, W5LV, W6LV	5	5	1	N/A
<b>EQUIPMENT SHELTER UNITS</b> W**A2P, W**AAP, WR**, D**AAP, HR**, H12A, H72A	5	5	1	N/A
<b>GEOTHERMAL/WATER SOURCE HEAT PUMPS</b> QW2S, QW3S, QW4S, QW5S	5	5	5	N/A
<b>CHILLED WATER</b> QC50 (No Compressor)	N/A	5	5	N/A
<b>GAS/ELECTRIC WALL-MOUNT</b> W24G, W30G, W36G, W42G, W48G, W60G, WG3S, WG4S, WG5S	5	5	5	10
<b>OIL FURNACES</b> ECM "V" Blower Models FC085, FH085, FH110, FLF075, FLF110, FLR075, FLR100, FLR130 PSC "D" Blower Models FC085, FH085D, FH110D, FLF085, FLF110, FLR085, FLR110, FLR140 SOF: SOF175, SOF265	N/A	N/A	10 ⑥	LIFETIME ④
	N/A	N/A	5	LIFETIME ④
	N/A	N/A	1	10
<b>ACCESSORIES</b> Factory/Field Installed Bard Ventilation and Heater Packages Bard branded Thermostats/Temperature Controllers LC1000, LC1500, LC2000, LC5000, LC6000, LV1000, MC4002, DC3003, TEC40, BG1000, PGD, PGDX Humidistats, CO <sub>2</sub> Controllers and all other field installed accessories not listed separately	N/A	N/A	5	N/A
	N/A	N/A	5	N/A
	N/A	N/A	1	N/A
	N/A	N/A	1	N/A

- ① For equipment that does not have an online warranty registration, the warranty period starts when the product was shipped from the factory.
- ② Heat transfer coils (refrigerant to air coils for air source and coaxial coils for water source units) are covered for leaks for 5 years. Physical damage to air side coils resulting in leaks or insufficient airflow, or fin deterioration due to corrosive atmosphere (such as acids, halogenated hydrocarbons or coastal environmental conditions) are not covered. Leaks in coaxial coils due to freezing of the coils are not covered. Copper coaxial coils for QW are not warranted for ground water/open loop installations.
- ③ Functional parts warranty is 1-year for all telecommunication, electric switch stations, pump stations and similar applications. This also applies to all OTR (over the road) applications.
- ④ Limited lifetime warranty on Heat Exchangers applies to original purchaser in private, owner occupied residences. Subsequent owners and commercial uses are warranted for 20 years from date of installation.
- ⑤ All OTR (over the road) applications that are moved from one location to another:  
Factory Warranty applies up to the point of initial start-up and test at all OEM manufacturing locations or subsequent outfitting facility. Once it goes into OTR service, the warranty expires immediately for compressor and sealed system components. This OTR exemption does not apply to relocatable classrooms, construction or office trailers.
- ⑥ Standard warranty for non-registered Oil Furnaces is 5-year parts. Must be registered at [www.wallmountwarranty.com](http://www.wallmountwarranty.com) within 90 days of installation for the 10-year parts coverage to be in effect.
- ⑦ Factory coated coils have a "5" year warranty in corrosive environments that are listed as approved.

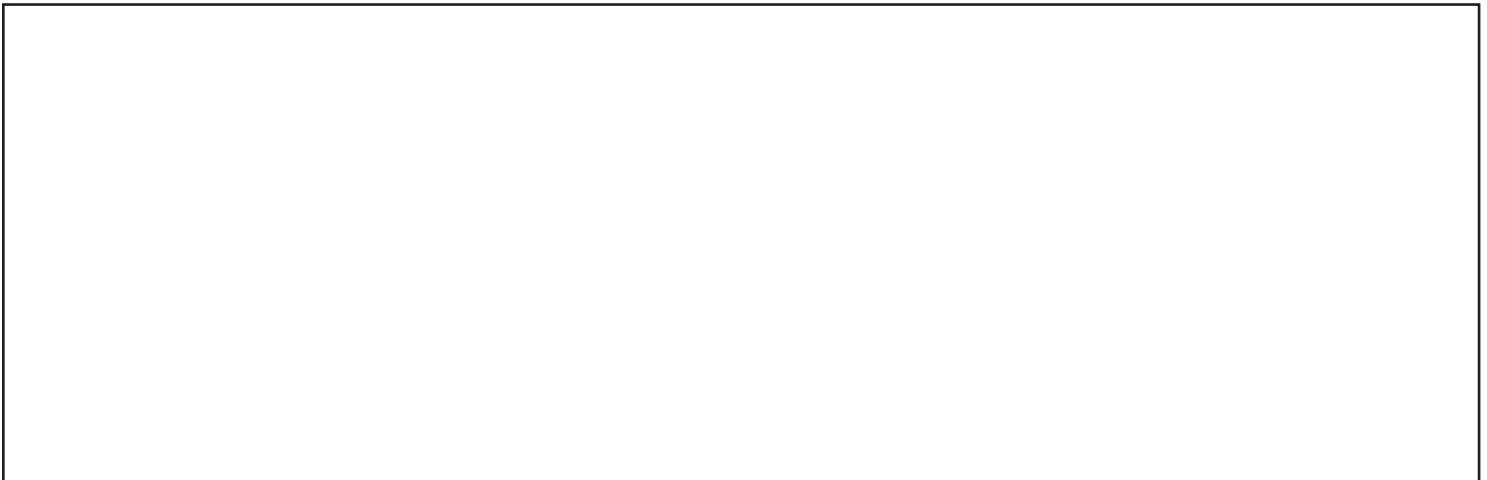

**Internet Resources**

Recognized as a leader in the HVAC industry, Bard combines quality products and outstanding service with innovation and technological advances to deliver high-performance heating and cooling products around the world. Please visit [www.bardhvac.com](http://www.bardhvac.com) for additional information regarding warranty and product information.