

A scientist wearing a grey lab coat, safety glasses, and blue gloves is working with a large quantity of clear glass bubbles in a large industrial machine. The machine has a circular opening with orange-colored blades or components. The scientist is looking intently at the bubbles. The background is a blurred industrial setting with bright lights.

3M Science.
Applied to Life.™

3M™ Glass Bubbles
Compounding and
Injection Molding
Guidelines

**Processing
for profit.**

Do more with 3M™ Glass Bubbles

3M™ Glass Bubbles offer a wealth of opportunities for plastics processors:

- Reduce final part weight by 15% or more
- Increase productivity by improving cycle time 15-25%
- Maintain or improve dimensional stability and other physical properties
- Reduce shrinkage and warpage
- Contribute to sustainability through better fuel economy

Product Spotlight: iM Series for Injection Molding

3M™ Glass Bubbles iM16K are the latest generation of high-strength glass microspheres, specially engineered for producing lightweight plastics. They feature an isostatic crush strength of 16,000 psi and a particle size of 20 microns. And with a density of just 0.46 g/cc, glass bubbles iM16K can deliver weight reductions of 15% or more – without compromising strength or other physical properties.

For higher pressure operations, 3M™ Glass Bubbles iM30K have a strength of 27,000 psi at a 0.60 g/cc density and a particle size of 18 microns.

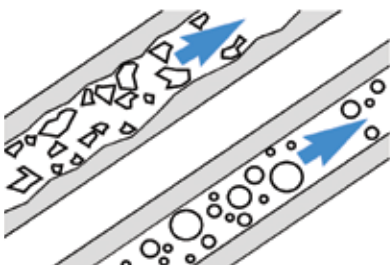

Unlike irregularly-shaped fillers, 3M glass bubbles roll easily over one another. This helps increase volume loading capacity, reduce shrinkage, and lower resin demand. It can also help reduce warpage in many molded plastic parts.

Introduction

3M™ Glass Bubbles are a family of high-strength, low-density additives used in a variety of industrial applications. They are available in a wide range of densities and crush strengths, including our new **iM Series**, engineered to survive the rigors of compounding and injection molding. They offer excellent survivability at the high pressures encountered in typical plastics processing operations. The chemically stable soda-lime-borosilicate glass composition of 3M glass bubbles provides excellent water and oil resistance.

Because of their spherical shape, glass bubbles behave like tiny ball bearings, causing them to flow within a liquid polymer much better than common mineral fillers. As a result, the impact on rheology (viscosity, melt-flow, etc.) is significantly less than the impact caused by mineral fillers.

A benefit of this is the ability to form highly-filled parts and/or parts with more complex geometries more easily. This can mean lower mold temperatures and lower injection pressures than would be possible when molding polymers filled with mineral fillers. In addition, the spherical shape (aspect ratio of 1.0) often improves the dimensional stability of the polymer composite, resulting in less shrinkage and warpage.

3M glass bubbles are compatible with most common thermoplastics, including polypropylene, nylon, ABS and others.



3M™ Glass Bubbles for Compounding/Injection Molding

3M Glass Bubble Product	Density (g/cc)	Minimum Fractional Survival (%)	Isostatic Crush Strength (psi)
iM30K	0.60	90%	27,000
S60HS	0.60	90%	18,000
iM16K	0.46	90%	16,000
S60	0.60	90%	6,000
K42HS	0.42	90%	7,500
K46	0.46	80%	6,000
S38HS	0.38	80%	5,500

Note: The purpose of these guidelines is to provide basic information to customers for use in evaluating and developing their own processes for compounding and injection molding using 3M glass bubbles. The information provided is general or summary in nature, and is offered to assist the customer. The information is not intended to replace the customer's careful consideration of the unique circumstances and conditions involved in the use and processing of 3M glass bubbles and other products. The customer is responsible for determining whether this information is suitable and appropriate for the customer's particular use and intended application.

Compounding

To compound polymers with 3M™ Glass Bubbles, 3M recommends the use of a compounding extruder, such as a twin-screw extruder or a Buss Kneader, with a downstream feedport for adding the glass bubbles to the polymer melt. The extruder screw flights beyond this point should be set up to impart a minimum amount of shear stress. Distributive mixing elements, such as gear mixers, are preferred. Aggressive dispersive mixing elements, such as reverse flight elements and kneading blocks, are not recommended. Single screw extruders are generally not recommended because they typically do not have a downstream port and often contain “barrier” designs or other narrow tolerance/high shear features. A system designed for adding chopped fiberglass to a polymer would be a suitable starting point when developing a low shear extrusion system for glass bubbles.

Feeding

In order to minimize glass bubble breakage, it is preferable to add the glass bubbles downstream from where the polymer is melted, rather than into the feedport with the polymer pellets. An auger-driven side feeder at the downstream port, rather than a simple open hopper, will provide the most consistent feeding behavior. Although not as critical as feed location or method, it is further advisable to minimize extruder screw speed and to minimize extruder outlet pressure.

Glass bubbles should be fed with an automated feeder. Although a volumetric feeder should produce satisfactory results, a gravimetric feeder – ideally one equipped with a twin shaft – is preferred. It is recommended that the glass bubbles be supplied to the feeder automatically; for example, using an automated vacuum feed system with a pre-hopper.

Like other fillers, glass bubbles can entrain some air into the polymer during feeding and compounding. If entrained air in the final compounded pellets is undesirable, use a vacuum vent downstream of the glass bubble feed port. Information on glass bubble handling can be found on pages 6-7.

Pelletizing

Any pelletizing method suitable for the polymer of choice is suitable for a system containing glass bubbles. For plastics highly-filled with glass bubbles, it might be advisable to use an underwater strand pelletizer or water slide pelletizer.

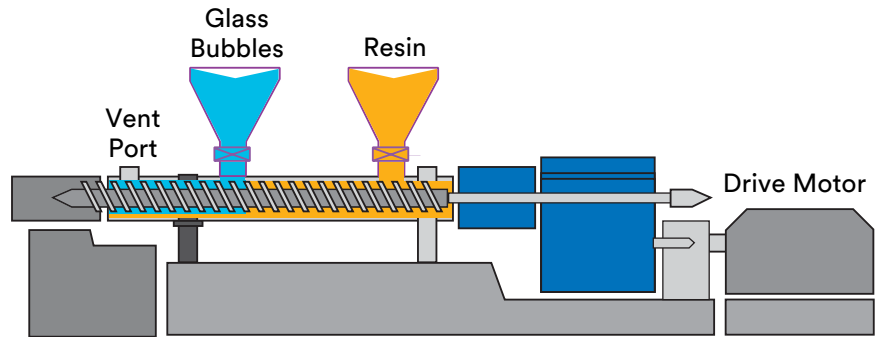

Figure 1. Typical setup on a twin-screw extruder

3M™ Glass Bubbles will become fluidized when aerated (which often occurs when initially filling a hopper) and this may lead to flooding of the hopper. To help prevent flooding, we recommend that the feeder discharge be covered until the hopper is filled with glass bubbles. Upon filling, the glass bubbles at the bottom will become de-aerated, and the feeder discharge may be uncovered in order to begin compounding. The hopper level should be maintained to at least 30% of its filled capacity, to prevent flooding during operation.



Injection Molding

3M™ Glass Bubbles can be used with all high performance engineered thermoplastics, such as TPO, TPU, PBT, PEEK, PPS and nylon. Their high strength and spherical shape minimize warpage and shrinkage, providing more control over finished part dimensions.

This also gives them the ability to form highly-filled parts more easily, allowing lower mold temperatures and lower injection pressures.

Equipment and Tooling Considerations

Although 3M™ Glass Bubbles iM16K, iM30K and S60HS are quite strong, they can be broken under extreme conditions. Therefore, part/mold design and processing should attempt to minimize the shear stress on the material.

A general-purpose, three-zone screw (feed, compression and metering) is recommended for processing compounds mixed with high-strength 3M glass bubbles. A L/D ratio of

Operating Parameters for 3M™ Glass Bubbles

Barrel Sizing	Compression Ratio	Injection Speed Low injection speed recommended.
Applies to all 3M glass bubbles	Low compression screw, typically 2:1 to 3:1	Note: Glass bubble-filled materials are subject to surface defects at high injection velocities. Careful control of the velocity profile will help to avoid or minimize these defects.

* Use intensification factor to calculate actual injection pressure – see page 5.

Figure 2. Equipment Recommendations

Processing Start-Up

All thermoplastics require unique start-up conditions, depending upon the polymer grade and the supplier. Processing conditions do not typically need to be altered when using 3M glass bubbles. However, because the addition of 3M glass bubbles does change the viscoelastic properties of the polymer, 3M recommends considering the following:

1. Slightly reduce the usual fill and screw speeds. At higher loading percentages, these speeds may need to be reduced even further.
2. Set the temperature at the upper end of the operating range in all zones.

Experimentation to optimize results is recommended.

16:1 to 22:1 is recommended for the metering section of the screw. The transition or compression zone should have a ratio between 2:1 and 2.5:1. For single flight extruder screws, 3M recommends that the feed and transition stages consist of 7 flights each, and the metering stage 6 flights. Dispersive mixing screws, such as barrier, vented or double wave, are not recommended for use with 3M glass bubbles. Distributive mixers are acceptable.

To allow smooth melt flow, a 100% “free flow, highly polished,” fluted screw tip valve assembly is recommended. A generous nozzle/sprue orifice dimension (0.25 in./5.5 mm) is recommended. The nozzle orifice or sprue orifice should be without sharp edges and have suitable dimensions of at least 0.25 inches.

For optimum mold filling, gate designs should incorporate full, round runners – the runner is cut in both plates – with an area of 0.5 square inches (comparable to about 0.125 radius). Modified trapezoidal runners, which do not require special alignment features (like the full round runners) can also be used. The cross-sectional area of the modified trapezoidal runner should be the same as a full round runner, which is 0.5 square inches.

The sprue used for processing 3M™ Glass Bubbles should be short, having a radius of 0.125 inches towards the nozzle, which is then tapered to 0.172 inches at the other end.

3M recommends using end-gated and/or fan-gated designs. Direct gating, with high injection pressures, can cause excessive bubble breakage. A minimum gate thickness of 0.06 inches should be used.

3M recommends the following:

- For long production molds, use tool steel hardened to Rockwell C-60+; for example, 4-20SS, S-7, H-13.
- Vent cavities at the end of the fill to minimize trapped gasses.
- Use largest-possible size gates.
- Reduce injection speeds.
- Machining marks can increase wear. A 4 microinch (.0001 mm) or better finish is recommended. Mold plating can also extend mold service life.
- Fan or parallel, edge gated designs have shown less bubble breakage, compared to direct gated designs.
- The pressure used to inject the resin into the mold should be below 25,000 PSI, as calculated using the hydraulic pressure multiplied by the machine's intensification ratio. Hydraulic pressure generally is reduced by increasing the melt temperature of the resin.

Some resin systems can be sensitive or degraded by the presence of the glass bubbles. The glass bubbles are pH basic and can react with PC and PC blends (PC/ABS), Polyester and some Fluoroplastics. Please contact your 3M representative for applications in these resins.

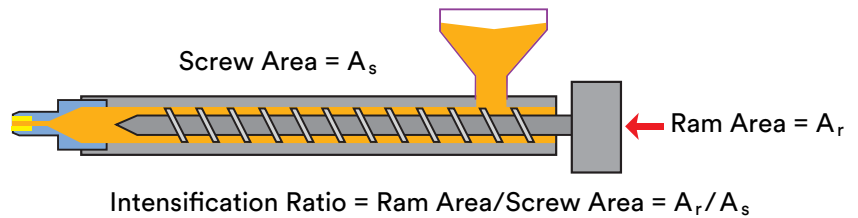

Figure 3. Calculating the Intensification Ratio of an Injection Molding Machine

Temperature Settings

Compounds containing 3M glass bubbles typically require higher mold temperatures than unfilled polymers. Melt on the high end of the polymer supplier's recommended temperature settings, to help lower viscosity and achieve a smoother, blemish-free surface.



Technical Library

Visit [3M.com/glassbubbles](https://www.3m.com/glassbubbles) to view our video library and download technical papers for more information on processing considerations, including: twin screw extruder configurations; the effect of processing conditions on glass bubble survival; discharging and transferring glass bubbles, and more.

Regrinding

Regrinding creates the potential for excessive glass bubble breakage, which can result in loss of desired physical properties of the polymer. It is recommended that grind be mixed with

adequate quantities of virgin pellets, and part testing be performed to ensure desired results are achieved.

Troubleshooting

Problem	Possible Cause	Possible Solution
Increased part density (higher than theoretical)	Excess glass bubble breakage	Reduce melt pressure during mold filling and packing stages
Mold not completely filled ("short shot")	Viscosity increase caused by addition of glass bubbles	Increase mold temperature
Surface Defects	Viscosity change; non-uniform dispersion of glass bubbles	Reduce injection speeds and/or increase mold temperature

Bag Unloading Guidelines

Bulk Bag

3M™ Glass Bubbles are available in large boxes of approximately 45 in. L × 47 in. W × 45 in. H (1.14 m × 1.19 m × 1.14 m) and in bulk bags of approximately 50 cubic feet (1.4 cubic meters) with a polyethylene liner and ten-inch bag lifting loops. There is a discharge spout in the base of the liner; the spout is 30 in. (0.76 m) in length, with a diameter of 22 in. (0.55 m). The filled bag size is approximately 45 in. W × 45 in. L × 46 in. H (1.14 m × 1.14 m × 1.17 m). Bags are stacked two per pallet then wrapped with a stretch film.

The maximum shipped height is 104 in. (2.64 m). The pallet is a two-way entry type. Typical shipping is in a "high cube" trailer or a 40 foot "high cube" seagoing shipping container. Bags are not returnable.

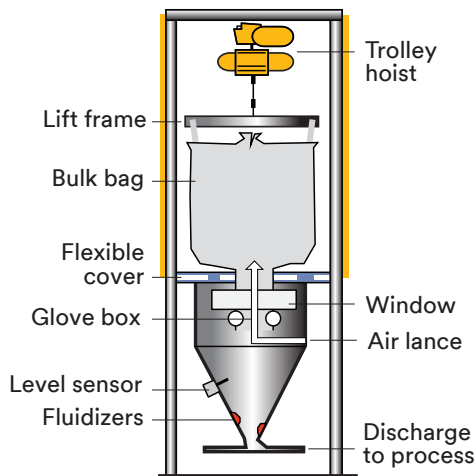

Vacuum Conveying

The vacuum transport system is a pull only conveying system and can be effectively used for unloading bags of glass bubbles. The pull system operates at a negative pressure, below atmospheric pressure. It may use a venturi, two-stage fan or a positive displacement blower to move the air that carries the material. The vacuum system will move material at higher line velocities than the pump system. The advantage is that it does not leak particles into the work area, and this system is not prone to line plugging problems. The primary filter is usually cleaned with pulsed, high-pressure, clean, dry air. A secondary filter is placed after the receiver filter in order to protect the fan or blower. An adjustable vacuum relief valve regulates vacuum in the receiver. Typical suction is 50 to 100 inches of water column. A hopper sight panel and cone aeration is suggested.

Sight Windows and Sight Tubes

Sight windows and sight tubes allow observation of glass bubbles flow in order to locate a problem in the transfer system. Suggested mounting locations are at the pump outlet or the bottom of vertical legs, or optionally at the receiving vessel entrance. Sight tubes use Pyrex™ glass or transparent PVC schedule 80 tubing. Grounding with a wire across the length of the sight tube is suggested. Polycarbonate material is suggested for windows.

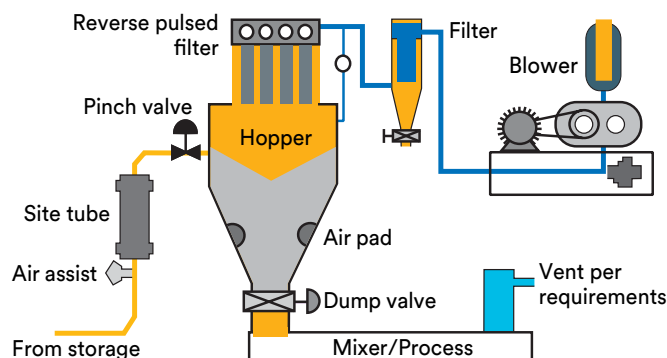

Figure 4. Glass Bubble Bag Transfer Via Vacuum

Double Diaphragm Pump

A double diaphragm pump is an alternative system which may also be used for unloading 3M™ Glass Bubbles. Typically, a three-inch pneumatic double-diaphragm pump is used to move lightweight powders. It is a lower cost method than a vacuum system that effectively transfers aerateable low bulk density powders. The air-driven pump is a combination pull/push, vacuum-pressure conveying system. The pump pulls material by vacuum into its inlet, then pushes the material along the conveying line with pressure. In the pressure conveying system poor line connections will leak dust into the workplace. The pump should be placed closer to the process rather than near the box in order to pull material a longer distance. This will reduce line plugging.

Purge air added into a pump chamber when it is pushing material into the line helps to decrease pump plugging and stalling. Often a vacuum relief valve is mounted close to the pump suction port. A bleed down valve at the pump outlet is suggested for relieving pressure from a plugged line or pump. Purging of the pump and the conveying system with air or other compatible gas is suggested before and after glass bubbles transfer.

Flow Aids

Air assists in the conveying line are used to keep conveying lines trouble-free. They are typically mounted at the bottom of vertical line legs and about every fifty feet in horizontal line runs. Air pads mounted near the discharge port in hoppers are suggested to help fluidize material for easy transfer.

Conveying Lines and Hoses

Conveying lines connect the various system components for glass bubbles handling. Typically, a transfer system uses 3 in. (76 mm) components. Glass bubbles should be transferred with a line velocity of less than 1200 ft/min (300 m/min). Lines with long radius bends or sweeps are suggested instead of ninety degree elbows. Lines can be combinations of rigid and flexible materials. All conveying lines and all components should be electrically grounded. Hoses with a smooth inner bore and a conductive drain wire are suggested. The drain wire must be connected to metal connectors. Flexible lines may range from braided chemical hose, semitransparent PVC, clear polyurethane to interlocking metal hose. Note, however, that some hoses are limited to use above 20°F (-7°C).

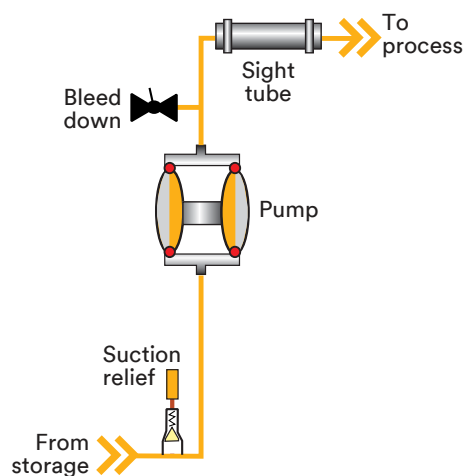

Figure 5. Double Diaphragm Pump

Product Storage

Ideal storage conditions include unopened cartons in a dry and temperature-controlled warehouse. Extended exposure of 3M glass bubbles boxes to high humidity and/or conditions susceptible to condensation may result in some amount of “caking” of the glass bubbles.

To minimize the potential for caking and thereby maximize storage life, the following suggestions are offered:

1. Carefully re-tie opened bags immediately after use.
2. If the polyethylene bag is punctured during shipping or handling, seal the hole as soon as possible or insert the contents into an undamaged bag.
3. During hot and/or humid months, store boxes in the driest, coolest space available.

If controlled storage conditions are unavailable, carry a minimum inventory, and process on a first in/first out basis.

Product Handling & Safety

Handling: Due to the low weight and small particle size of 3M™ Glass Bubbles, dusting may occur while handling and processing. To minimize the dusting potential during handling, consider the following:

- Do not open glass bubbles packages until ready to use.
- Upon opening, have an air siphon near the opening to pull away airborne particles. (Dust collection equipment may be required – check local OSHA and other applicable regulations.)
- Remove glass bubbles with a suction “wand” (with slight positive pressure aeration) and transfer to a closed mixing tank inside fully contained piping. If a closed mixing tank is not available, use dust collection equipment as close as practical to the point of entry. Pneumatic conveyor systems have been used successfully to transport glass bubbles without dusting from shipping containers to batch mixing equipment. Equipment vendors should be consulted for recommendations.
- Static eliminators should be used to prevent static buildup.

Safety: For worker protection, please consider the following

- Use safety glasses with side shields for eye protection.
- An air-purifying respirator suitable for particulates may be selected for protection after an optional exposure assessment is performed for your specific application. (For additional information about personal protective equipment, refer to the product Safety Data Sheet.)
- Use with appropriate local exhaust ventilation/ dust collection in the work area.

Refer to the 3M glass bubbles Safety Data Sheet for additional safety information

Additional Information

3M glass bubbles are supported by global sales, technical and customer service resources, with fully-staffed technical service laboratories in the U.S., Europe, Japan, Latin America and Southeast Asia. Users benefit from 3M’s broad technology base and continuing attention to product development, performance, safety and environmental issues.

For additional technical information on 3M glass bubbles in the United States, call 3M Advanced Materials Division, **800-367-8905**.

For other 3M global offices, and information on additional 3M products, visit our web site at: **www.3M.com/glassbubbles**.

Warranty, Limited Remedy, and Disclaimer: Many factors beyond 3M’s control and uniquely within user’s knowledge and control can affect the use and performance of a 3M product in a particular application. User is solely responsible for evaluating the 3M product and determining whether it is fit for a particular purpose and suitable for user’s method of application. User is solely responsible for evaluating third party intellectual property rights and for ensuring that user’s use of 3M product does not violate any third party intellectual property rights. Unless a different warranty is specifically stated in the applicable product literature or packaging insert, 3M warrants that each 3M product meets the applicable 3M product specification at the time 3M ships the product. 3M MAKES NO OTHER WARRANTIES OR CONDITIONS, EXPRESS OR IMPLIED, INCLUDING, BUT NOT LIMITED TO, ANY IMPLIED WARRANTY OR CONDITION OF MERCHANTABILITY OR FITNESS FOR A PARTICULAR PURPOSE OR ANY IMPLIED WARRANTY OF NON-INFRINGEMENT OR ANY IMPLIED WARRANTY OR CONDITION ARISING OUT OF A COURSE OF DEALING, CUSTOM OR USAGE OF TRADE. If the 3M product does not conform to this warranty, then the sole and exclusive remedy is, at 3M’s option, replacement of the 3M product or refund of the purchase price.

Limitation of Liability: Except where prohibited by law, 3M will not be liable for any loss or damages arising from the 3M product, whether direct, indirect, special, incidental or consequential, regardless of the legal theory asserted, including warranty, contract, negligence or strict liability.

Technical Information: Technical information, recommendations, and other statements contained in this document or provided by 3M personnel are based on tests or experience that 3M believes are reliable, but the accuracy or completeness of such information is not guaranteed. Such information is intended for persons with knowledge and technical skills sufficient to assess and apply their own informed judgment to the information. No license under any 3M or third party intellectual property rights is granted or implied with this information.



Advanced Materials Division
3M Center
St. Paul, MN 55144 USA

Phone 1-800-367-8905
Web www.3M.com/glassbubbles

Pyrex is a trademark of Corning Glass Works.
3M is a trademark of 3M Company.
Used under license by 3M subsidiaries and affiliates.

Please recycle. Printed in USA. © 3M 2016.
All rights reserved. Issued: 12/16 12234HB
98-0212-3815-3 Rev. C