



**204**  
**WEIGHT INDICATOR**  
**INSTALLATION and TECHNICAL MANUAL**



8555-M313-01 Rev G  
06/12

PO BOX 151 WEBB CITY, MO 64870  
PH (417) 673-4631 - FAX (417) 673-5001  
[www.cardinalscale.com](http://www.cardinalscale.com)

Printed in USA

Technical Support: Ph: 866-254-8261 • [techsupport@cardet.com](mailto:techsupport@cardet.com)





# TABLE OF CONTENTS

Specifications ..... Page 1  
 European Declaration of Conformity ..... Page 2  
 Site Preparation Requirements ..... Page 3  
 Installation ..... Page 4  
     Unpacking ..... Page 4  
     Mounting ..... Page 4  
     Interconnections ..... Page 4  
     AC Power Adapter ..... Page 4  
     Batteries ..... Page 5  
         Battery Installation/Replacement ..... Page 6  
         Low Battery Indicator ..... Page 6  
         Battery Status ..... Page 7  
         Battery Charging ..... Page 7  
     Load Cell Connection ..... Page 7  
     Load Cell Connections with Over 30 Feet of Cable ..... Page 7  
     Main PCB and Jumpers (Figure No. 5) ..... Page 8  
 Serial Interface Specifications ..... Page 8  
 Serial Data Formats ..... Page 9  
 Keypad Functions ..... Page 10  
 Annunciators ..... Page 11  
 Setup and Calibration ..... Page 13  
 Setup Review ..... Page 18  
 Calibration Seal Installation ..... Page 19  
 Care and Cleaning ..... Page 19  
 Error and Status Displays ..... Page 20  
 Before You Call Service ..... Page 20  
 204 Parts Identification ..... Page 22

SERIAL NUMBER _____ DATE OF PURCHASE _____ PURCHASED FROM _____ _____ _____ _____ RETAIN THIS INFORMATION FOR FUTURE USE
--

**PRECAUTIONS**

**Before using this indicator, read this manual and pay special attention to all "WARNING" symbols:**

 <p><b>IMPORTANT</b></p>	 <p><b>ELECTRICAL WARNING</b></p>	 <p><b>STATIC SENSITIVE</b></p>
---	--	---

## FCC COMPLIANCE STATEMENT

**WARNING!** This equipment generates uses and can radiate radio frequency and if not installed and used in accordance with the instruction manual, may cause interference to radio communications. It has been tested and found to comply with the limits for a Class A computing device pursuant to Subpart J of Part 15 of FCC rules, which are designed to provide reasonable protection against such interference when operated in a commercial environment. Operation of this equipment in a residential area may cause interference in which case the user will be responsible to take whatever measures necessary to correct the interference.

You may find the booklet "How to Identify and Resolve Radio TV Interference Problems" prepared by the Federal Communications Commission helpful. It is available from the U.S. Government Printing Office, Washington, D.C. 20402. Request stock No. 001-000-00315-4.

---

## PROPER DISPOSAL

When this device reaches the end of its useful life, it must be properly disposed of. It must not be disposed of as unsorted municipal waste. Within the European Union, this device should be returned to the distributor from where it was purchased for proper disposal. This is in accordance with EU Directive 2002/96/EC. Within North America, the device should be disposed of in accordance with the local laws regarding the disposal of waste electrical and electronic equipment.

It is everyone's responsibility to help maintain the environment and to reduce the effects of hazardous substances contained in electrical and electronic equipment on human health. Please do your part by making certain that this device is properly disposed of. The symbol shown below indicates that this device must not be disposed of in unsorted municipal waste programs.



All rights reserved. Reproduction or use, without expressed written permission, of editorial or pictorial content, in any manner, is prohibited. No patent liability is assumed with respect to the use of the information contained herein. While every precaution has been taken in the preparation of this manual, the Seller assumes no responsibility for errors or omissions. Neither is any liability assumed for damages resulting from use of the information contained herein. All instructions and diagrams have been checked for accuracy and ease of application; however, success and safety in working with tools depend to a great extent upon the individual accuracy, skill and caution. For this reason the Seller is not able to guarantee the result of any procedure contained herein. Nor can they assume responsibility for any damage to property or injury to persons occasioned from the procedures. Persons engaging the procedures do so entirely at their own risk.

## SPECIFICATIONS

Power Requirements:	115 VAC 50/60Hz 12 VDC 300mA wall plug-in UL/CSA listed AC power adapter, Cardinal part number 728R90. Also available, for 230 VAC operation, Cardinal part number 6800-1045 OR (6) C cell batteries, Alkaline, Ni-Cad or NiMH (batteries not included)
Operating Temperature:	14 to 104 °F (-10 to +40 °C)
Display:	Six digit, seven segment, 1" high LCD
Sensitivity:	1.2uV/division (0 to 3.0 mV/V), Class III
Signal Input Range:	0.2mV to 15mV max.
Transducer Excitation:	5.0 VDC
Number of Load Cells:	up to 4 each 350Ω
Load Cell Cable Length:	30 feet max.
Resolution:	5,000 divisions
Capacities:	1,000 to 5,000 divisions commercial up to 10,000 divisions noncommercial
Division Value:	1, 2, 5 or 10 x 1, 0.1, 0.01, 0.001
Sample Rate:	1 to 10 samples per second selectable
Auto Zero Range:	0.5 or 1 through 9 divisions
Weighing Units:	Pounds, kilograms, ounces or grams
Keyboard:	Membrane type with 7 keys
Enclosure Size:	8" W x 6 5/8" H x 2 1/8" D (204 x 168 x 54mm)
Enclosure Construction:	304 Stainless Steel
Weight:	2.1 lb (without batteries) – 3.1 lb (with batteries)

### Certifications

This equipment is certified to comply with the requirements for a Class III/IIIL device by the

- National Conference on Weights and Measurements (Certificate No. 02-016A1)
- Measurement Canada (Approval No. AM-5436)
- Australian Government National Standards Commission (Approval No. S430)
- And for accuracy Class III and IIIIL by OIML (Certificate No. R76/1992-DK-02.03)



# EUROPEAN DECLARATION OF CONFORMITY

Manufacturer: Cardinal Scale Manufacturing Company  
PO Box 151  
203 East Daugherty  
Webb City, Missouri 64870 USA

Telephone No. 417 673 4631  
Fax No. 417 673 5001

Product: Non-automatic Weight Indicating Instrument  
Model Numbers 204, 204S  
Serial Number EXXXYY-ZZZ  
where XXX = day of year  
YY = last two digits of year  
ZZZ = sequential number

The undersigned hereby declares, on behalf of Cardinal Scale Manufacturing Company of Webb City, Missouri, that the above-referenced product, to which this declaration relates, is in conformity with the provisions of:

Council Directive 2006/95/EC Low Voltage Directive

European Standard EN50082: 1995 for radiated emissions and  
European Standard EN50082-2: 1995 Class B for EMC immunity.

The Technical Construction File required by this Directive is maintained at the corporate headquarters of Cardinal Scale Manufacturing Company, 203 East Daugherty, Webb City, Missouri.



Mark Levels  
Quality Assurance Administrator

# SITE PREPARATION REQUIREMENTS

The Model 204 Weight Indicator is a precision weight indicating instrument. As with any precision instrument, it requires an acceptable environment to operate at its peak performance and reliability. This section is provided to assist you in obtaining such an environment.

## Environmental

The Model 204 Weight Indicator meets or exceeds all certification requirements within a temperature range of 14 to 104 °F (-10 to +40 °C).

In order to keep cooling requirements to a minimum, the indicator should be placed out of direct sunlight and to provide adequate air circulation, keep the area around the indicator clear.



Do not place the indicator directly in front of a heating or cooling vent. Such a location will subject the indicator to sudden temperature changes, which may result in unstable weight readings.

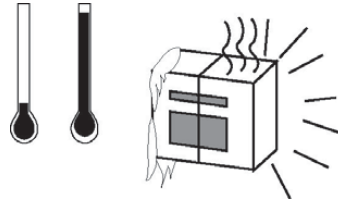

Insure that the indicator has good, clean AC power and is properly grounded. In areas subject to lightning strikes, additional protection to minimize lightning damage, such as surge suppressors, should be installed.

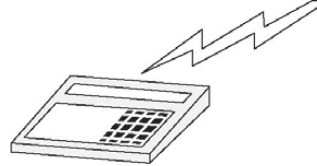

## Electrical Power

The 204 indicator has been designed to operate from 115 VAC @ 50/60Hz using a 115 VAC to 12 VDC 300 mA wall plug-in UL/CSA listed AC power adapter. **NOTE!** For 230 VAC operation, an optional AC power adapter is required, Cardinal part number 6800-1045.

- The socket-outlet supplying power to the indicator should be on a separate circuit from the distribution panel and dedicated to the exclusive use of the indicator.
- The socket-outlet shall be installed near the equipment and shall be easily accessible.
- The wiring should conform to national and local electrical codes and ordinances and should be approved by the local inspector to assure compliance.
- On installations requiring 230 VAC power, **it is the responsibility of the customer** to have a qualified electrician install the proper power adapter plug that conforms to national electrical codes and local codes and ordinances.

# INSTALLATION

## Unpacking

Carefully remove indicator from shipping carton and inspect it for any damage that may have taken place during shipment. Keep carton and packing material for return shipment if it should become necessary. The purchaser is responsible for filing all claims for any damages or loss incurred during transit.

**Should your indicator come already installed on a scale, the following installation information does not apply to you.**

## Mounting

The Model 204 Weight Indicator may come mounted on a column or it may be mounted on a desktop or other smooth, flat, horizontal surface or it may be mounted on a wall using two (2) #10 screws placed 6.00 inches apart on the wall. Refer to Figure No. 1 for illustrations of the mounting bracket. This bracket may be removed or left in place for desktop use.

Regardless of how and where you mount indicator, it should be in a safe area where it will not be in the way of normal traffic. The location chosen should be free of temperature extremes and water, is not subject to direct sunlight and should be mounted where the display is easily viewed and within easy reach of the operator.

If wall mounted, make certain the structure and mounting bolts are of sufficient strength to support the indicator. The mounting bracket should be securely fastened to the wall so it cannot break loose.

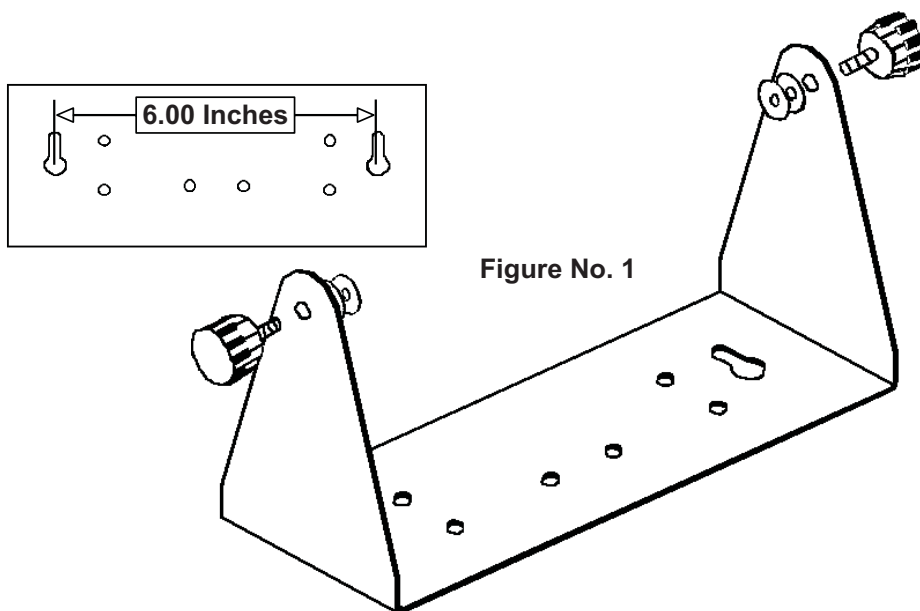

## Interconnections

All Input, Output and power connections to the 204 are made at the rear panel of the indicator. Connections for the Load Cell input and the RS-232 Serial I/O are all made via 9 pin "D" shaped subminiature connectors. The optional 12VDC wall plug-in UL/CSA listed AC adapter is connected using a power jack. Refer to Figure No. 2 for the layout of the rear panel.

## AC Power Adapter

To power the 204 using the 12VDC wall plug-in AC power adapter, connect the plug from the adapter into the power jack on the back of the indicator and then plug the power adapter into the proper electrical outlet. Refer to Figure No. 2.



## INSTALLATION, CONT.

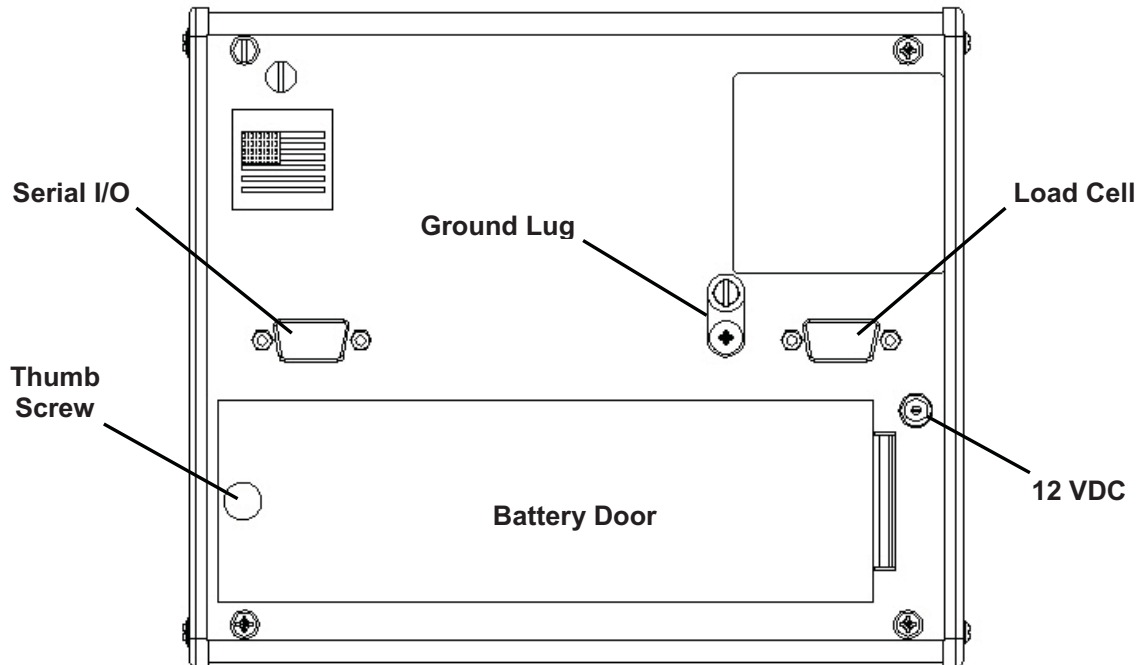

Figure No. 2

### Batteries

The 204 indicator can use 6 "C" size Alkaline, Ni-Cad or NiMH batteries (*not included*). You must first obtain and install batteries in the 204 before operations can begin. The batteries are contained in a battery holder inside the indicator. Access is via a removable panel on the back of the indicator.

The 204 can operate for 200 hours of continuous use when using Alkaline batteries or with fully charged Ni-Cad or NiMH batteries, 50 hours of continuous use.



**IMPORTANT!** The 204 indicator can be operated from Alkaline, Ni-Cad or NiMH batteries or from an AC power adapter. All six (6) batteries must be of the same type. They must all be Alkaline, all Ni-Cad or all NiMH. **DO NOT** mix Alkaline and Ni-Cad or NiMH batteries.



**IMPORTANT!** The AC power adapter is also used to recharge the batteries, when the 204 is operated from Ni-Cad or NiMH batteries. **DO NOT** connect the AC power adapter to the 204 if using Alkaline batteries. Also, when using Alkaline batteries, make sure the *n i C h d* setup option is disabled (set to 0). Refer to Setup and Calibration or Setup Review.

**CAUTION:** RISK OF EXPLOSION IF BATTERY IS REPLACED BY AN INCORRECT TYPE. DISPOSE OF USED BATTERIES ACCORDING TO THE INSTRUCTIONS.

**ATTENTION:** RISQUE D'EXPLOSION SI LA BATTERIES EST REMPLAC'E PAR UN TYPE INCORRECT. REJETEZ LES BATTERIES UTILISE'ES SELON LES INSTRUCTIONS.

## INSTALLATION, CONT.

### Battery Installation/Replacement

To install or remove the batteries, the following steps should be followed:

1. Make sure the AC power adapter is unplugged.
2. Remove the indicator from the mounting bracket and turn the indicator over so that the display is facing away from you.
3. Locate the rectangular panel on the back of indicator and remove the thumb screw.
4. Remove the panel (lift straight up and slide it out) exposing the battery holder.
5. If installing new batteries, proceed to step 6. If replacing the batteries, remove all 6 batteries from the battery holder and then proceed to step 6.
6. Install the new 6 "C" size batteries in the holder, noting the polarity markings located in the battery holder. Refer to Figure No. 3.
7. After placing all 6 batteries in holder, replace panel on back of indicator (slide tab into slot on rear panel) and install thumb screw.
8. Turn the indicator over (display facing up) and press the **ON|OFF** key.
9. If display turns on, batteries have been installed correctly. If not, remove panel and check for one or more improperly positioned batteries.
10. Return the indicator to the mounting bracket.
11. The indicator is now ready for operation.

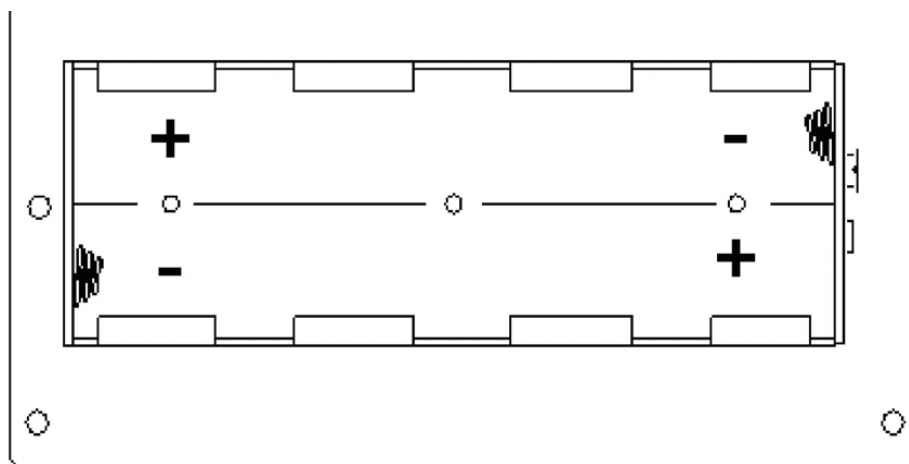

Figure No. 3

### Low Battery Indicator

When the batteries are near the point they need to be replaced (Alkaline) or recharged (NiCad or NiMH), the low battery annunciator on the display will turn on (see Figure No. 7). If the battery voltage drops too low for accurate weighing, the indicator will automatically shut off and you will be unable to turn it back on.

#### Using Alkaline Batteries

When the low battery annunciator turns on, turn the indicator off, remove the old batteries and replace with new ones.

#### Using NiCad or NiMH Batteries

When the low battery annunciator turns on (and the *n. CHD* setup option is enabled, set to 1 or 2), plug the AC power adapter into the indicator and then into the proper electrical wall outlet. The indicator will begin charging the batteries.

# INSTALLATION, CONT.

## Battery Status

If batteries are used, the indicator will show the battery status on power up. The display will show *bAttErY* then change to  $\equiv YY \equiv$ , where YY indicates the remaining battery voltage expressed as a percentage (%) of the total battery voltage.

## Battery Charging

To recharge the Ni-Cad or NiMH batteries, the AC power adapter must be connected to an AC power outlet and plugged into the indicator. It will take approximately 15 hours to fully recharge the batteries in the scale. While the batteries are charging the 204 can still be operated. Note that charging the batteries for more than 15 hours *will not* damage them.

When the 204 is to be turned off, pressing the **ON/OFF** key once will display "dashes" scrolling across the display indicating the batteries are being charged. Pressing the **ON/OFF** key again, will display *OFF* and turn the 204 off. If the AC power adapter is disconnected before the 15 hours, the indicator will continue to charge the batteries when the AC power adapter is plugged back in.

**NOTE: When the 204 is turned off, the indicator is NOT charging the batteries.**

## Load Cell Connection

The load cell cable connects to the 204 via a 9-pin "D" connector on the rear panel of the indicator. Figure No. 4 shows the pin identification for the load cell connector. Make certain that the pins are correctly identified before soldering a wire to them. Use the connector retaining screws to hold the load cell cable connector securely to the rear panel.

<u>PIN NO.</u>	<u>FUNCTION</u>
1	+EXCITATION
2	-SIGNAL
3	no connection
4	-SENSE
5	SHIELD
6	-EXCITATION
7	+SIGNAL
8	no connection
9	+SENSE

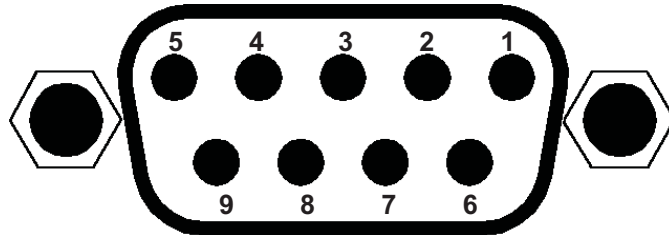

Figure No. 4

## MATING CONNECTOR INFORMATION

<u>DESCRIPTION</u>	<u>ITEM</u>	<u>Cardinal Part #</u>
CONNECTOR	DE9-P	6610-2379
CONNECTOR SHELL	C883010001	6610-1131

## Load Cell Connection with Over 30 Feet of Cable

For installations with over 30 feet of cable between the indicator and the load cells, sense wires should be used. The sense wires must be connected between the +SENS and the -SENS terminals on the indicator and the +EXCITATION and the -EXCITATION wires of the load cells or the +SENS and -SENS terminals of the load cell trim board or the section seal trim board. For the indicator to utilize the sense wires, the sense jumpers must be open.

# INSTALLATION, CONT.

## Main PCB and Jumpers

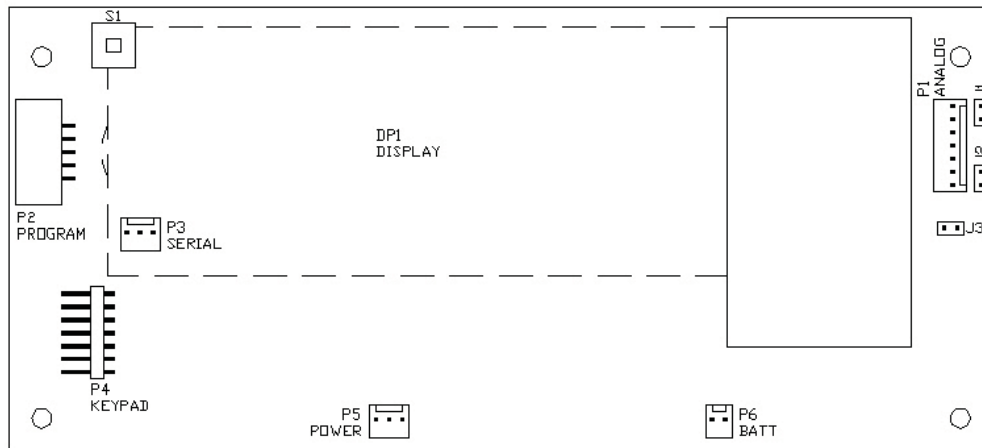

Figure No. 5

### J1 and J2 - Sense Jumpers

If sense leads are NOT used, you must install plug-in jumpers at J1 and J2 (adjacent to the P1 connector). These jumpers attach the sense leads to the excitation leads. If sense leads ARE used, these plug-in jumpers should be positioned on one plug-in pin only or removed and stored for later use. Refer to Figure No. 5 for the location of the jumpers.

### J3 - Dead Load Boost Jumper

For very low dead loads (less than 10% of the combined load cell capacity) connect the dead load boost jumper J3 on the printed circuit board. Refer to Figure No. 5 for jumper location.

**NOTE!** Remove the left end cap to access the jumpers. Refer to Figure No. 9.

## SERIAL INTERFACE SPECIFICATIONS

Your Model 204 has a RS-232 serial port that may be connected to a printer to record weight and associated data or it may be connected to a remote display (like the SB-80) or to a computer for transmission of weight data. The weight data may be transmitted on demand (pressing the **PRINT** key or on receipt of a command from the computer) or continuously. Figure No. 6 shows the Serial I/O connector along with the identity of the pins used.

PIN NO.	FUNCTION
2	DATA INPUT (RXD)
3	DATA OUTPUT (TXD)
5	SIGNAL GROUND (GND)

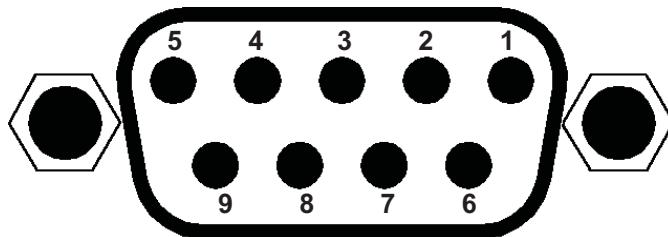

Figure No. 6

The 204 RS-232 serial interface can be configured during the setup and calibration procedure or during the setup review operation. Using either method, it is possible to select the operation of the serial interface as well as select the baud rate.

- The baud rates supported are: 1200, 2400, 4800, 9600, 19.2K and 38.4K baud.
- The data format is fixed at 8 bits, No parity, and 1 stop bit.
- The indicator is shipped from the factory with the baud rate set to 9600 baud.

# SERIAL DATA FORMATS

## Weight-On-Demand

If the Printer Continuous output was not selected,  $\text{Cont} = 0$  (0=NO) during setup and calibration of the indicator, and the 204 is connected to a computer, it will transmit a single set of weight data each time the computer sends an ENQ (hex 05) or a SMA weight request (W). This is known as Weight-On-Demand. Examples and explanation of the data format transmitted are shown below.

## Continuous Output

If the Printer Continuous output was selected  $\text{Cont} = 1$  (1=YES) during setup and calibration, the 204 will transmit weight data continuously. If connected to a remote display, the display will continuously show weight data. An example and explanation of the data format transmitted is shown below.

## Weight-On-Demand and Continuous Output Data Format

The data format transmitted for *both* Weight-On-Demand and Continuous Output will be GROSS weight only. The weight data always includes the units of measure. An example of the data output (with and without a decimal point) is shown below:

Pxxxxx^UU^M^SS^CR (no decimal point in weight display)

PxxxxxD^UU^M^SS^CR (decimal point in weight display)

where:

P =	Polarity	(space if positive, - if negative)
xxxxx =	Weight	(Six digits with leading spaces)
^ =	Space	
D =	Decimal Point	(embedded where necessary)
UU =	Units	LB, KG, OZ, ^G
M =	Mode	G = (gross)
SS =	Status	CZ = center-of-zero, O = motion, BZ = below zero and OC = over capacity)
CR =	Carriage Return	(hex 0D)

## SMA Weight On Demand Format

The host device (computer) sends:

<lf> W <cr>

The 204 will respond:

<lf><s><r><n><m><xxxxxx><uuu><cr>

where:

lf =	Line Feed	
s =	Flags	Z= center of Zero, O = Over cap, E = zero Error, e = weight not currently being displayed
r =	Range	1, 2, 3, ...
n =	Mode	G = Gross
m =	Motion	M = Motion, " "(blank) = no motion
xxxxx.xxx =	Weight	Ten digits (includes decimal point). Weight is right justified.
uuu =	Units	lb^, kg^, oz^, g^^ (^ = space)
cr =	Carriage Return	(hex 0D)

# KEYPAD FUNCTIONS

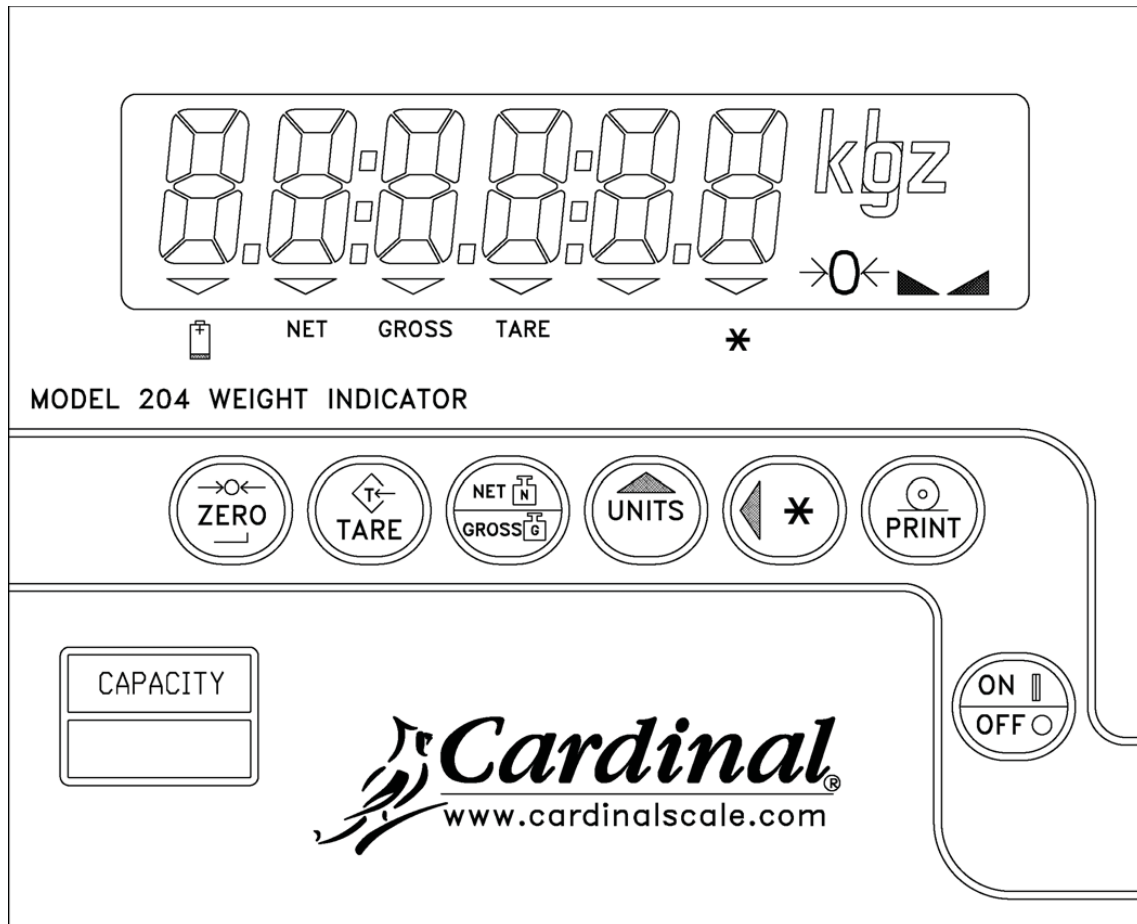

Figure No. 7



The membrane keypad is not to be operated with pointed objects (pencils, pens, fingernails, etc). Damage to keypad resulting from this practice is NOT covered under warranty.

## ON / OFF (I / O) KEY

With the indicator off, pressing this key will apply power to the 204 and turn on the display. If the indicator is already on, pressing this key will remove power from the indicator.

## →0← ZERO KEY

This key is used to reset the display to zero up to the selected limit of either 4% or 100% of the scale capacity. The zero limit is set during setup and calibration of the indicator.

## TARE KEY

Pressing the **TARE** key alone will cause the current gross weight to be stored as the new tare weight and cause the weight display to change to the net weight display mode (Net annunciator will turn on).

## NET / GROSS KEY

This key is used to toggle between Net and Gross weight modes. The selected mode is indicated by turning on the appropriate annunciator on the display. Note that if no valid tare weight has been entered, pressing this key will cause a momentary display *not TARE* and the indicator will remain in the Gross weight mode.

## KEYPAD FUNCTIONS, CONT.

### UNITS / ▲ (UP ARROW) KEY

This key is used to change the weighing units to the alternate units of measurement if selected during setup of the indicator (WEIGHTING UNITS = 3 or 4). For example, with pounds displayed (lb annunciator turned on) pressing this key will change the weighting units to kilograms (kg annunciator will turn on). **NOTE!** This feature must be enabled during setup and calibration for this key to be operational. This key is also used during setup and calibration to increment the value.

### \* / ◀ (ASTERISK / LEFT ARROW)

This key is used to lock and unlock the display. If enabled during setup and calibration, (Hold Key Enable), pressing this key (after obtaining a stable weight value) will cause the indicator to lock onto the weight and turn on the asterisk annunciator on the display. Pressing this key a second time will unlock the display and turn off the asterisk annunciator. This key is also used during setup and calibration to select the digit to change.

**NOTE! The lock feature is for non-commercial (NOT "Legal for Trade") applications.**

### ⊙ PRINT

Pressing this key will initiate the transmission of weight data via the serial I/O port unless the continuous data output feature was enabled during setup and calibration or setup review.

**NOTE!** If the continuous data output feature was selected, this key will be disabled. This key is also used to save the current setting during setup and calibration.

**NOTE! The indicator will not respond to the Print command unless the weight display is stable. If displaying gross weight, the only weight printed is gross weight. If displaying net weight, the gross, tare, and net weights are printed.**

The 204 includes support for *nControl*. *nControl* is a PC based program that can design a ticket then download the ticket information to the indicator. The 204 allows 2 programmable formats in addition to the standard print tab settings format. **NOTE!** When the **PRINT** key is pressed the indicator looks for the selected format. If no "nControl" ticket is found, the default ticket is used.

```
#2
100.00 lb G
20.00 lb T
80.00 lb N
```

**SAMPLE TICKET**

*For more information on nControl, refer to the nControl Fast Start Guide.*

## ANNUNCIATORS

The annunciators are turned on to indicate that the display is in the mode corresponding to the annunciator label or that the status indicated by the label is active.

### →0← (Center-of-Zero)

The Center-of-Zero annunciator is located to the right of the weight display and is turned on to indicate that the weight is within +/- 1/4 division of the center of zero.

### ▴▴ (Stable)

The (Stable) annunciator is located to the right of the weight display and is turned on when the weight display is stable. When off, it means that the change in successive weight samples is greater than the motion limits selected during setup and calibration of the indicator.

## ANNUNCIATORS, CONT.

### **lb**

The lb annunciator is located on the right of the weight display and is turned on to show that the displayed weight units is pounds.

### **kg**

The kg annunciator is located on the right of the weight display and is used to indicate that the displayed units of weight measurement is kilograms.

### **oz**

The oz annunciator is located on the right of the weight display and is turned on to show that the displayed weight units is ounces.

### **g**

The g annunciator is located on the right of the weight display and is used to indicate that the displayed units of weight measurement is grams.

### **Low Battery**

The low battery annunciator  is used with the battery operation. It will turn ON to indicate that the batteries will soon need to be replaced (if using Alkaline) or recharged (if using NiCad or NiMH). No change in operation will occur until just before the battery voltage drops to a level where operation is affected. At this level, the indicator will automatically turn itself off.

### **NET**

The NET annunciator is turned on to show that the weight displayed is the net weight. Net weight is determined by subtracting the stored tare weight from the gross weight. The tare weight is usually the weight of the empty container. Note that the NET annunciator is only active when a tare weight value is stored.

### **GROSS**

The GROSS annunciator is turned on to show that the weight displayed is the gross weight. Gross weight will be displayed when no tare weight value is stored.

### **TARE**

The TARE annunciator is turned on to show that the indicator is in a weight mode in which a known tare (container) weight value is stored.

### **\* (ASTERISK)**

The \* (ASTERISK) annunciator is turned on to show that the indicator is locked onto the weight.

**NOTE!** The lock feature (Hold Key Enable) must be enabled during setup and calibration. In operation, pressing the \* / ◀ key (after obtaining a stable weight value) will cause the indicator to lock onto the weight and turn on the annunciator. Pressing the \* / ◀ key a second time will unlock the display and turn off the annunciator.



# SETUP AND CALIBRATION

Your 204 indicator has been thoroughly tested and calibrated before being shipped to you. If you receive the indicator with a scale, calibration is not necessary. If the indicator is being connected to a scale for the first time or recalibration is necessary for other reasons, proceed as indicated.

Calibration of the 204 indicator is accomplished entirely by the keypad. To enter the setup and calibration mode:

1. With the power off, remove the Calibration Access Screw on the upper left corner of the rear panel, see Figure No.8.
2. With the screw removed, insert a small non-metallic tool into the screw hole and press and hold the calibration switch.
3. Press the **ON/OFF** key.
4. The display will show *unt*. The indicator is now ready for setup and calibration.

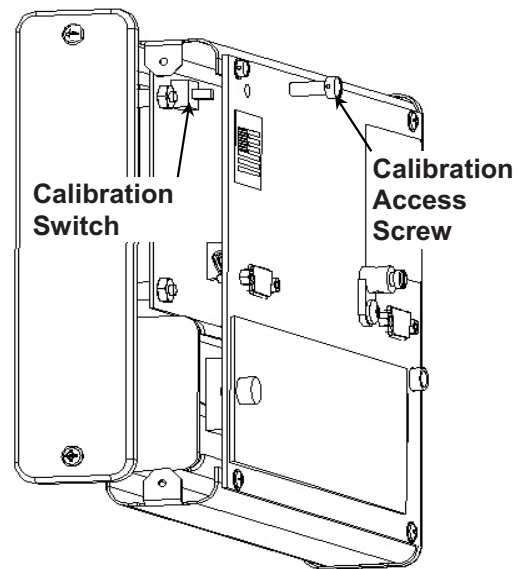

Figure No. 8

During the setup and calibration process it will be necessary to enter operational parameters via the 204's keyboard. Pressing the **PRINT** key will cause the data entered or displayed to be retained and the 204 will advance to the next prompt. The cursor location is identified by the blinking character and can be advanced to the left to the next position by pressing the **ASTERISK** key. Pressing the **UNITS** key will change the blinking character to the next value.

## Scale Interval

With the display showing *unt*: press the **ASTERISK** key to show the current setting. Press the **UNITS** key until the proper scale interval (1, 2, 5, 10 or 20) is displayed and then press the **PRINT** key to store the displayed value and proceed to the next prompt.

## Flash

To display *FLASH*, press the calibration switch while the display is showing the prompt *unt*: (Scale Interval). With the display showing *FLASH*, press the **PRINT** key. The display will change to show *0* (0=NO). Press the **PRINT** key to proceed to the next prompt *unt*: (Weighing Units). To return to the *unt*: prompt, start the setup and calibration process over.

**THE FLASH UPDATE OPTION IS AVAILABLE IN THE 204 INDICATOR AND IN NCONTROL WITH REV 2.0 OR GREATER.**

## Weighing Units

With the display showing *unt*: press the **UNITS** key to show the current setting. If the value shown is acceptable, press the **PRINT** key again to save it, otherwise press the **UNITS** key to enter the new weighing units and press the **PRINT** key to save the new setting.

- |                    |                      |                |
|--------------------|----------------------|----------------|
| 0 = None           | 3 = Pounds/Kilograms | 6 = Grams Only |
| 1 = Pounds Only    | 4 = Kilograms/Pounds |                |
| 2 = Kilograms Only | 5 = Ounces Only      |                |

## SETUP AND CALIBRATION, CONT.

### Decimal Point Location

With the display showing  $dPP$ : press the **ASTERISK** key to show the current setting. Press the **UNITS** key until the number corresponding to the desired decimal point position is displayed. Press the **PRINT** key to store this setting and proceed to the next step.

0 = XXXXX      1 = XXXX.X      2 = XXX.XX      3 = X X.XXX

### Scale Capacity

With the display showing  $CRP$ : press the **ASTERISK** key to show the current setting. Press the **UNITS** key to enter the proper digit at the blinking location. Press the **ASTERISK** key to step to the left and the next digit location. Repeat the process until all digits of the capacity have been entered. Should you make a mistake and press the **ASTERISK** key with an incorrect digit entered, it will be necessary to press the **ASTERISK** key until the blinking character returns to the proper location, and then use the **UNITS** key to enter the correct digit. After all digits have been correctly entered, press the **PRINT** key to store the capacity and advance to the next step.

### Calibration

With the display showing  $CRL$ : press the **ASTERISK** key. The display will change to show the current setting 0 (0=NO). If the scale has been previously calibrated and you wish to skip calibration and proceed to  $LRZ$ , the Zero Tracking Range, simply press the **PRINT** key and the internal calibration factor will be retained.

To begin calibration, press **UNITS** to select 1 (1=YES), then press the **PRINT** key. After pressing the **PRINT** key the display will change to  $LRd$ .

### Load Calibration Weight

The display will now indicate  $LRd$ : which is a prompt for the entry of the calibration weight value and placement of this amount of test weights on the scale platform.

1. Make certain the scale platform is empty and free of debris, then place the desired amount of calibrated test weights on the scale platform. It is recommended that a minimum of 50% of the scale's capacity be used but 70% to 100% is preferred.
2. Press the **PRINT** key.
3. Determine the exact amount of test weights to be placed on the scale platform and enter this value into the 204 by using the **UNITS** and **ASTERISK** keys in the same manner used to enter the scale's capacity. Verify that the numbers entered are the same as the total weight of test weights, and the least significant digit agrees with the scale interval.
4. Press the **PRINT** key.

After a moment the display will indicate the message  $unLRd$  which is a request that the test weights be removed from the scale platform. Remove the weights then press the **PRINT** key. The calculated calibration factor is now stored in the 204's nonvolatile memory.

### Zero Tracking Range

The display will now indicate  $LRZ$ . Press the **ASTERISK** key to show the value assigned to the Automatic Zero Tracking Range. This is the value in scale divisions that will be automatically zeroed off. Values of 1 through 18 (1 to 9 divisions by 0.5 divisions) are available for the zero tracking range. Entry of two zeros (00) will disable the zero tracking feature. Use the **UNITS** key to step through these available values. Once the proper value is shown press the **PRINT** key to store the value.

## SETUP AND CALIBRATION, CONT.

### USA (Domestic or International)

The display will next indicate  $USA$ . This is the prompt to select whether the 204 is used in the USA (domestic) or outside the US (international). Press the **ASTERISK** key to show current setting, then press the **UNITS** key to select 1 (1=YES, Domestic) or 0 (0=NO, International).

#### USA = 1 (Domestic)

No Zero Limit  
Tare Resolution = 1d (1 division)

#### USA = 0 (International)

+/- 2% Zero Limit  
Tare Resolution = .25d (1/4 division)  
Lamp test on power up enabled (display segments 1 second on, 1 second off)

Once the correct value is shown press the **PRINT** key to save the setting.

### Motion (Unstable) Range

The display will now show  $Un5$ . Press the **ASTERISK** key to show the current setting. Changes in weight exceeding the selected number of divisions will cause the STABLE weight annunciator to turn off. Values from 1 to 9 divisions may be selected by pressing the **UNITS** key. Once the correct value is shown press the **PRINT** key to save the setting.

### Digital Filter Level Selection

The display will now show  $FLt$  which is the prompt for the selection of the digital filtering level. Your 204 will arrive with the factory filter setting (1=minimal) already entered. Please check with your scale service technician should you wish to change the programmed filter level and break range. Four levels of filtering are available. They are as follows:

0 = NO FILTERING	2 = MODERATE FILTERING
1 = MINIMAL FILTERING	3 = CUSTOM FILTERING



**NOTE: Selection 3, Custom Filtering is used when 0, 1 or 2 are inadequate.**

Press the **ASTERISK** key to show the current setting. Then press the **UNITS** key to select the desired level of filtering. Press the **PRINT** key to save the setting.

#### $F$ - Filter Level

If you select Custom Filtering, the 204 will display  $F$ . Press the **ASTERISK** key to show the current setting for the Filter Level. The filter level is a number from 1 to 16 that corresponds to the level of filtering with 16 being the greatest filtering and 1 the least. Use the **UNITS** and **ASTERISK** keys to select the filter level and then press the **PRINT** key to save the setting.

#### $br$ - Break Range

Next, the 204 will display  $br$ . Press the **ASTERISK** key to show the current setting for the Break Range. The break range is a number from 1 to 64 that corresponds to the number of division change to break out of filtering. Use the **UNITS** and **ASTERISK** keys to select the break range value and then press the **PRINT** key to save the setting.

### Sample Rate

The display will now show  $sr$ . Press the **ASTERISK** key to show the current setting. The sample rate may be set from a minimum of 1 sample per second to a maximum of 10 samples per second in one sample per second intervals. Press the **UNITS** key until the desired sample rate is displayed. Press the **PRINT** key to save the setting.

## SETUP AND CALIBRATION, CONT.

### Hold Key Enable

The display will next indicate  $HLd$ : which is the prompt for the selection to enable or disable the Hold (ASTERISK) key. This mode of operation will lock the 204 display and is used only in noncommercial applications. Press the **ASTERISK** key to show the current setting, then press the **UNITS** key to select 1 (1=YES, enable) or 0 (0=NO, disable). Press the **PRINT** key to save the setting.

**NOTE!** This feature must be set to 0 (0=NO) for “Legal for Trade” applications.

### Battery Type

With the display showing  $n \text{ } \mathcal{R}d$ : press the **ASTERISK** key to show current setting and then press **UNITS** to select the type of batteries to be used. **NOTE!** This setting may be revised without having to enter the calibration mode.

$n \text{ } \mathcal{R}d$ :

- 0 Alkaline batteries - battery charging is DISABLED
- 1 NiCad or NiMH batteries - battery charging is ENABLED
- 2 Battery charging is ENABLED and FORCED ON. This selection forces battery charging for NiCad or NiMH batteries that are discharged. **NOTE!** After 15 hours of charging, the indicator will automatically change the  $n \text{ } \mathcal{R}d$ : setting back to a 1.

Once the correct value is shown press the **PRINT** key to save the setting.



**CAUTION:** Selecting 1 or 2, enables battery charging. **DO NOT** select 1 or 2 when using Alkaline batteries.

### Power Up Zero

With the display showing  $PUD$ : press the **ASTERISK** key to show current setting, then press **UNITS** to select 1 (1=YES, enable) or 0 (0=NO, disable). Press the **PRINT** key to save the setting. **NOTE!** This setting may be revised without having to enter the calibration mode.

- If 1=YES is selected, the weight display will be reset to zero automatically on power up.
- If 0=NO is selected, the weight display will not be reset to zero.

### Automatic Shutoff

The display will now show  $RSH$ :. This Automatic Shutoff feature will automatically turn the 204 off after a predetermined period of inactivity to prolong battery life. To turn the indicator back on you must press the **ON / OFF** key.

Press the **ASTERISK** key to show the current setting. Use the **UNITS** key to select the number (1 through 9) of minutes (*time approximate*) of inactivity before turning the 204 off. A 0 disables the Automatic Shutoff feature. Press the **PRINT** key to save the setting. **NOTE!** This setting may be revised without having to enter the calibration mode.

## SETUP AND CALIBRATION, CONT.

### Sleep Mode

The display will now show *SLP-*. The Sleep Mode feature also conserves battery power when the indicator remains unused for a selected period of time. With the feature enabled, the load cell excitation will be reduced and the display will show *SLEEP*. The Sleep feature requires that the indicator remain at the center of zero to activate, unlike the Automatic Shutoff feature which only requires no motion. Weight placed on the scale will activate the indicator and return it to the weight mode. **NOTE!** This setting may be revised without having to enter the calibration mode.

Press the **ASTERISK** key to show the current setting. To enable, use the **UNITS** key to select the number (1 to 9) of minutes (*time approximate*) of inactivity at zero before the indicator will enter the Sleep mode. Press the **PRINT** key to save the setting. Enter a 0 to disable the Sleep mode. **NOTE!** This setting may be revised without having to enter the calibration mode.

### Baud Rate Selection

The display will now show *baud*. Press the **ASTERISK** key to show the current setting. If acceptable, press the **PRINT** key to save it. Otherwise use the **UNITS** key to select the desired baud rate and press the **PRINT** key to save the setting. **NOTE!** The FACTORY setting is 3 (9600 baud) and may be revised without having to enter the calibration mode. The following baud rates are available:

0 = 1200    1 = 2400    2 = 4800    3 = 9600    4 = 19,200    5 = 38,400

### Print Ticket Format

The display will now show *Print-*. Press the **ASTERISK** key to view the current setting. If acceptable, press the **PRINT** key to save it. Otherwise use the **UNITS** key to *change* the selected print ticket format. Allowable values are:

0 = Default Format    1 = nControl Format 1    2 = nControl Format 2

### Continuous Output

The display will now show *Cont-*. Press the **ASTERISK** key to view the current setting. If a 1 (1=YES) is displayed, the feature has been enabled and the 204 will send a continuous output of weight data to the serial I/O connector. If a 0 (0=NO) is displayed the data will only be transmitted when the **PRINT** key is pressed or on receipt of an ENQ command from a computer. Press the **UNITS** key to change between 1 (YES) and 0 (NO). Once the proper setting is displayed, press the **PRINT** key to save the setting. **NOTE!** This setting may be revised without having to enter the calibration mode.

### End-Of-Print Line Feeds

The display will now show *EOP-*. At the end of a data transmission to a printer, the 204 can send a number of line feed commands to space the paper in the printer to the desired position for withdrawal or for the next print. Press the **ASTERISK** key to view the current setting. If the setting shown is acceptable, press the **PRINT** key to save it. Otherwise, use the **UNITS** key to select the desired number of line feeds (0 to 99). With the desired number displayed, press the **PRINT** key to save the setting. **NOTE!** This setting may be revised without having to enter the calibration mode.

### Done

The indicator display will now show *done*. The setup and calibration process has been completed. Remove the power from the indicator and re-assemble for use.

## SETUP REVIEW

The 204 allows several operational parameters to be reviewed and changed as necessary without having to enter the setup and calibration mode. The parameters in the setup review will be processed in the following sequence:

<i>n iCAd:</i>	Disable battery charging (use Alkaline batteries), Enable battery charging (use Ni-Cad or NiMH) or Enable battery charging and Force charging of discharged Ni-Cad or NiMH batteries.
<i>PUD:</i>	Enable or Disable automatic reset of weight display to zero on power up.
<i>ASH:</i>	Disable or select number of minutes for automatic shutoff timer.
<i>SLP:</i>	Disable or select number of minutes of inactivity at zero for sleep mode.
<i>bAUD:</i>	Select baud rate for serial I/O port.
<i>Prt:</i>	Select the ticket format to be used when the <b>PRINT</b> key is pressed.
<i>Cont:</i>	Enable or Disable the continuous output.
<i>EoP:</i>	The Number of Ending Linefeeds Printed.

### To Enter the Setup Review Mode

1. Turn the 204 off.
2. Press and hold the **PRINT** key and then press the **ON/OFF** key.
3. The display will then prompt with *n iCAd*, the selection to use Ni-Cad (NiMH) or Alkaline batteries.
4. Refer to the instructions listed in the Setup and Calibration section of this manual for information on how to change these parameters.

## CALIBRATION SEAL INSTALLATION

If your Model 204 Weight Indicator is used in a commercial application it must be tested and sealed by your local weights and measurement official. The 204 is designed to accept a lead and wire security seal to prevent unauthorized access to the calibration adjustments. Refer to the Figure No. 9 for details on the installation of the seal.

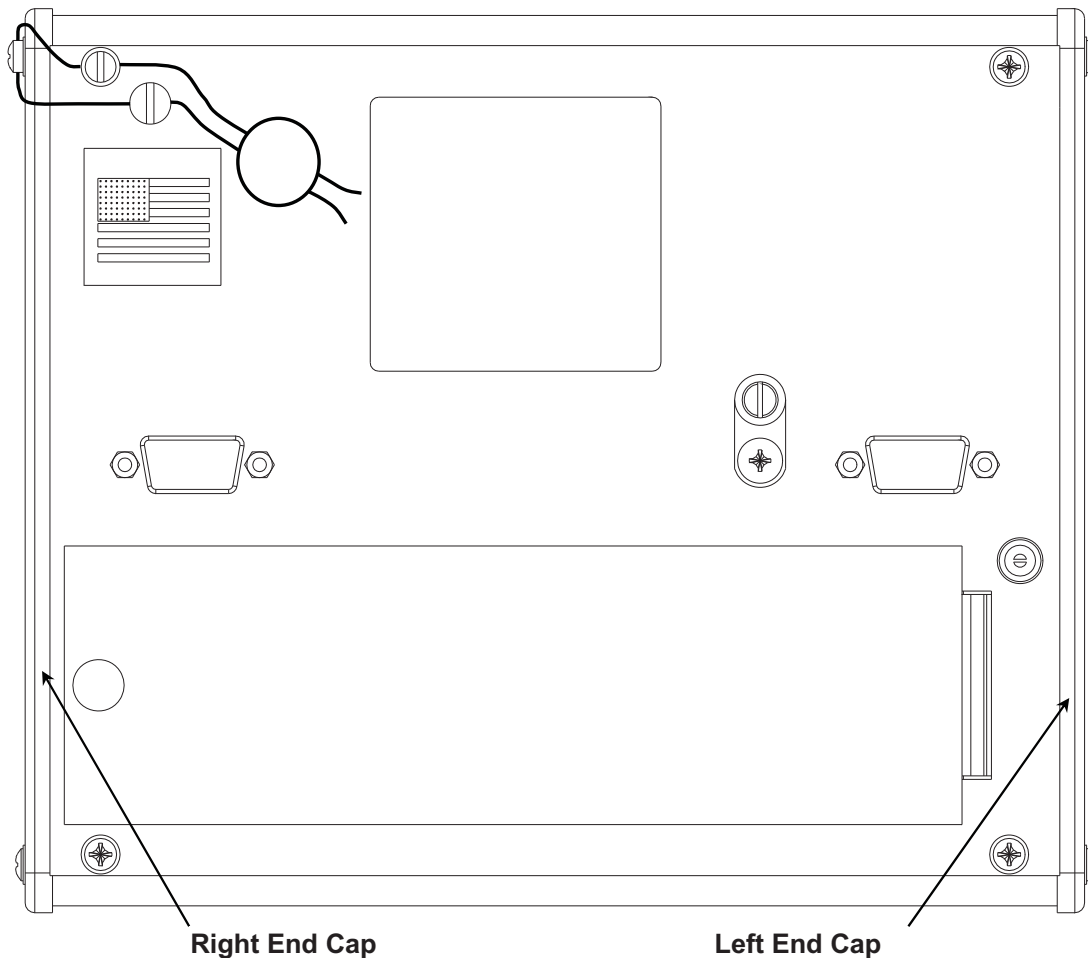

(Indicator as viewed from rear)

Figure No. 9

## CARE AND CLEANING

1. **DO NOT** submerge indicator in water, pour or spray water directly on indicator.
2. **DO NOT** use acetone, thinner or other volatile solvents for cleaning.
3. **DO NOT** expose equipment to temperature extremes.
4. **DO NOT** place equipment in front of heating/cooling vents.
5. **DO** clean the indicator with a damp soft cloth and mild non-abrasive detergent.
6. **DO** remove power before cleaning with a damp cloth.
7. **DO** provide clean AC power and adequate protection against lightning damage.
8. **DO** keep the surroundings clear to provide clean and adequate air circulation.

## ERROR AND STATUS DISPLAYS

The 204 is equipped with a diagnostic software program that tests various portions of the indicator's circuitry and verifies proper operation. Should a problem be detected, an error or status message will be displayed alerting the operator to that condition. The following lists these errors and status displays and their meaning:

<b>Display</b>	<b>Meaning</b>
<i>-UnS-</i>	Motion is present when the 204 is attempting to perform one of the following operations: Power Up Zero or Zero Weight Display
<i>-OF-</i>	Attempting to display a negative number greater than -99,999 or a positive number greater than 99,999
<i>-OCAP-</i>	Scale weight exceeds scale capacity
<i>CALib</i>	Indicates improper stored calibration data, calibration is necessary.
<i>Ad Err</i>	The analog to digital circuit has failed. Consult the scale service representative.
<i>Err A</i>	The analog to digital sample is invalid.
<i>ErrAL</i>	The load cell input is below the range of the indicator.
<i>ErrAH</i>	The load cell input is above the range of the indicator.
<i>EE Err</i>	NOVRAM failure. Consult the scale service representative.
<i>-tRL-</i>	Indicates an attempt to zero a weight outside the scale zero range. (See Four Percent Zero Tracking Range Limit).
<i>bAttery</i>	Indicates the remaining battery voltage expressed as a percentage (%) of the total battery voltage.
<i>nOtare</i>	Attempting to switch to Net mode without a tare value.
<i>-Err-</i>	General error, invalid keypad entry was attempted.
<i>OFF</i>	Displayed to indicate the 204 is turning off.

## BEFORE YOU CALL FOR SERVICE

The 204 has been designed to provide you with years of trouble-free operation. In spite of this, troubles sometimes happen. Before calling for service assistance you should make some initial checks to verify that a problem does exist. The following describes several types of symptoms along with suggested remedies.

<b>Problem</b>	<b>Possible Solutions</b>
Display does not turn on	<p><b>AC Operation:</b> Is the AC power cord fully inserted into the wall receptacle? Check wall receptacle for proper AC power. Try another electrical appliance in the same receptacle, does it work? Check the circuit breaker. Has there been power failure?</p> <p><b>Battery operation:</b> Check if batteries are installed and correctly. Are batteries discharged? Replace if Alkaline or recharge if NI-CAD or NiMH.</p>
Incorrect weight displayed	Has the indicator been calibrated? Insure that the scale platform isn't touching an adjacent object. Check the load cell connector wiring. If using four (4) wire load cells, insure the sense lead jumpers (J1 & J2) are installed. If using a low dead-load scale, install the dead load boost jumper, J3. Have proper operation procedures been followed?
Indicator will not display weight	Refer to Error and Status Display section and make certain that the <i>O CAP</i> message is not displayed. If so, and scale is not loaded, perform the calibration sequence.





# 204 PARTS IDENTIFICATION

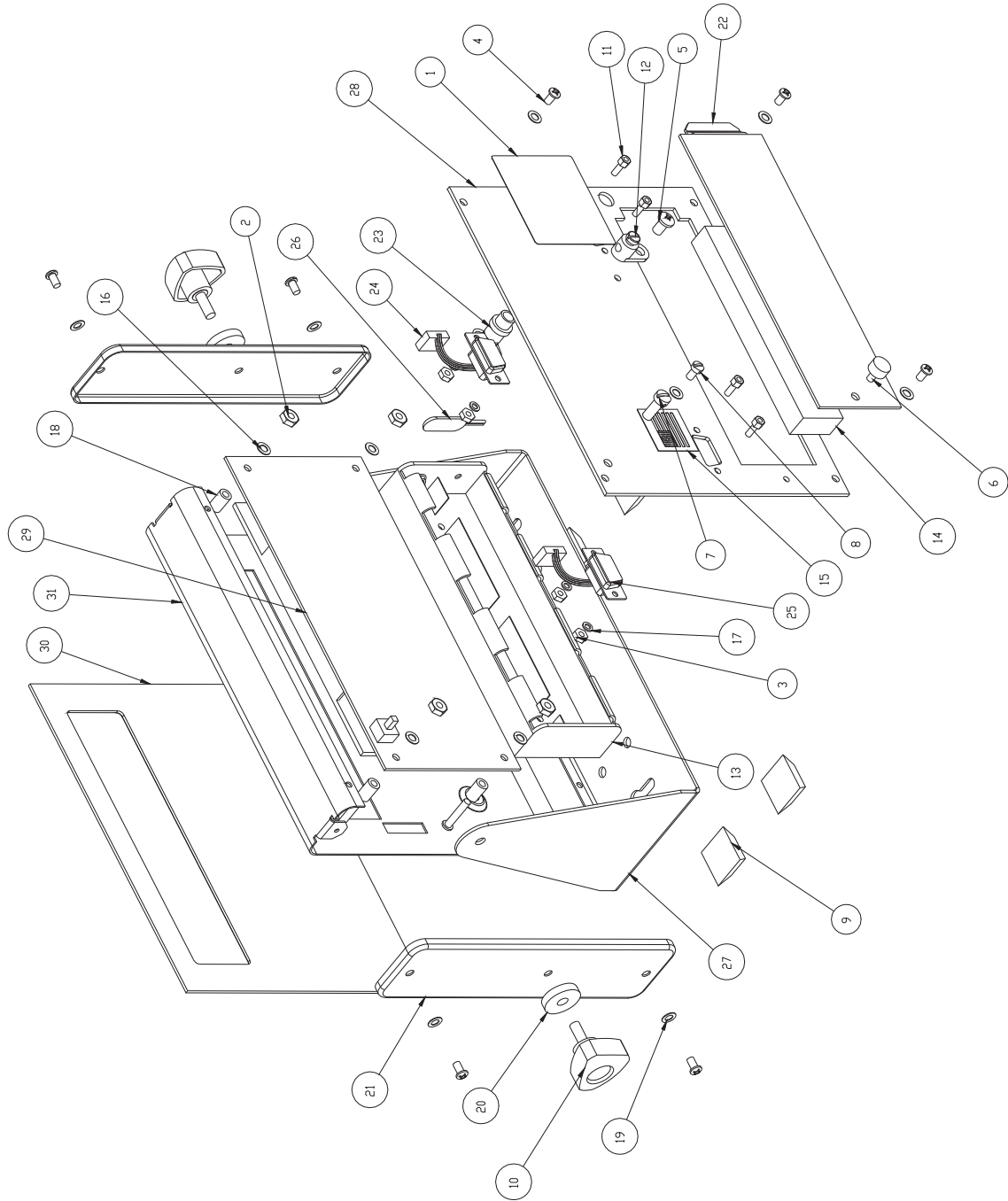

## 204 PARTS IDENTIFICATION

ITEM	PART NO.	QTY	DESCRIPTION
1	593GR986	1	SERIAL TAG
2	6013-0039	5	NUT HEX #6-32
3	6013-0245	4	HEX NUT #4-40
4	6021-0661	6	SCW PAN HEAD #6-32 x .25 S.S.
5	6024-0037	1	#10 SPLIT LOCK WASHER
6	6021-1032	1	THUMB SCRW, 6-32 x 0.25
7	6021-1108	2	SCW FILLISTER MACHINE-SCW #10-32 x .375 S.S.
8	6021-2071	2	SCW FILLISTER #6-32 x .250 S.S.
9	6540-1050	4	RUBBER FOOT
10	6540-1052	2	ENCLOSURE KNOB 1.18 DIA. X .44
11	6610-2000	4	JACK SOCKET
12	6610-5002	1	GROUND LUG
13	6610-5119	1	BATTERY HOLDER 6-C CELLS
14	6650-0018	1	GASKET MATERIAL 1" x 1/2" x 4 5/8"
15	6650-0087	1	LABEL: MADE IN THE USA
16	6680-0004	5	WASHER LOCK INT. TOOTH #6 Z/P
17	6680-0052	4	WASHER LOCK #4 Z/P
18	6680-0131	5	SPACER (PCB) #6 x .4
19	6680-1006	8	WASHER LOCK INT. TOOTH #6 S.S.
20	6680-1008	2	SPACER #10 x .155
21	8555-B173-18	2	END CAP, 758CSV
22	8555-B176-08	1	BATTERY DOOR
23	8555-B308-0A	1	CABLE: POWER CORD
24	8555-B309-0A	1	CABLE: LOAD CELL
25	8555-B310-0A	1	CABLE: SERIAL
26	8555-B312-0A	1	CABLE: BATTERY
27	8555-C146-08	1	DISPLAY STAND
28	8555-C304-18	1	REAR PANEL
29	8555-D301-0A	1	CONTROLLER BOARD
30	8555-D302-08	1	KEYPAD
31	8555-C306-0A	1	FRONT PANEL ASSEMBLY
*	728R90	1	AC ADAPTER 115VAC/12VDC @ 300MA
*	6800-1045		OPTIONAL AC ADAPTER 100-240VAC/12VDC @ 1 AMP

\* NOT SHOWN

# STATEMENT OF LIMITED WARRANTY

## WARRANTY TERMS

Cardinal Scale Manufacturing Company warrants the equipment we manufacture against defects in material and workmanship. The length and terms and conditions of these warranties vary with the type of product and are summarized below:

PRODUCT TYPE	TERM	MATERIAL AND WORKMANSHIP	LIGHTNING DAMAGE	WATER DAMAGE	CORROSION ON-SITE	LIMITATIONS AND REQUIREMENTS
		See note 9	See note 7	See note 4	LABOR	
VEHICLE SCALE WEIGHT INDICATORS	1 YEAR	YES	YES	YES	YES	NO 1,2,3,5,6 A,B,C,D
VEHICLE SCALE LOAD CELLS Ex. Hydraulic	5 YEARS	YES	YES	YES	YES	90 DAYS 1,2,3,5,6 A,B,C,D
HYDRAULIC LOAD CELLS	LIFE	YES	YES	YES	YES	90 DAYS 1,5,6,8,10 A,B,C,D

PRODUCT TYPE	MATERIAL AND WORKMANSHIP		LIGHTNING DAMAGE	WATER DAMAGE	CORROSION ON-SITE LABOR		LIMITATIONS AND REQUIREMENTS
	TERM	See note 9	See note 7	See note 4	See note 4	See note 7	See note 4
VEHICLE SCALE STRUCTURE	5 YEARS	YES	YES	YES	YES	90 DAYS	1,2,3,5,6 A,B,C,D,E
ALL OTHER CARDINAL PRODUCTS	1 YEAR	YES	NO	YES	YES	NO	1,2,5,6 A,B,C,D,E
REPLACEMENT PARTS	90 DAYS	YES	NO	YES	YES	NO	1,2,4,5,6 A,B,C,D
IN-MOTION VEHICLE SCALES	1 YEAR	YES	NO	YES	YES	90 DAYS	1,2,5,6 A,B,C,D



Ph. (800) 441-4237  
 E-mail: cardinal@cardet.com  
 203 E. Daugherty  
 Webb City, MO 64870

12/11  
 Printed in USA  
 315-WARRANTY-CAR-H

## **APPLICABLE LIMITATIONS AND REQUIREMENTS**

1. This warranty applies only to the original purchaser. The warranty does not apply to equipment that has been tampered with, defaced, damaged, or had repairs or modifications not authorized by Cardinal or has had the serial number altered, defaced or removed.
2. This warranty is not applicable to equipment that has not been grounded in accordance with Cardinal's recommendations.
3. This equipment must be installed and continuously maintained by an authorized Cardinal dealer.
4. Applies only to components constructed from stainless steel.
5. This warranty does not apply to equipment damaged in transit. Claims for such damage must be made with the responsible freight carrier in accordance with freight carrier regulations.
6. Warranty term begins with date of shipment from Cardinal.
7. Only if device is constructed for outdoor use.
8. Lifetime warranty applies to damages resulting from water, lightning, and voltage transients and applies only to the hydraulic load cell structure itself (does not include pressure transducers, rubber seals, o-rings, and associated wiring).
9. Except for hydraulic load cells, warranty coverage for damage resulting from lightning is valid ONLY when the device is installed in strict accordance with Cardinal's installation instructions including the use of recommended grounding and surge suppression circuitry.
10. Life is considered to be a period of ten (10) years after shipment.

## EXCLUSIONS

- A.)** This warranty does not include replacement of consumable or expendable parts. The warranty does not apply to any item that has been damaged due to unusual wear, abuse, improper line voltage, overloading, theft, fire, lightning, water, prolonged storage or exposure while in purchaser's possession or acts of God unless otherwise stated herein.
- B.)** This warranty does not apply to peripheral equipment not manufactured by Cardinal. This equipment will normally be covered by the equipment manufacturer's warranty.
- C.)** This warranty sets forth the extent of our liability for breach of any warranty or deficiency in connection with the sale or use of our product. Cardinal will not be liable for consequential damages of any nature, including but not limited to loss of profit, delays or expenses, whether based on tort or contract. Cardinal reserves the right to incorporate improvements in material and design without notice and is not obligated to incorporate said improvements in equipment previously manufactured.
- D.)** This warranty is in lieu of all other warranties expressed or implied including any warranty that extends beyond the description of the product including any warranty of merchantability or fitness for a particular purpose. This warranty covers only those Cardinal products installed in the forty-eight contiguous United States and Canada.
- E.)** This warranty does not cover paint coatings due to the variety of environmental conditions.



Ph. (800) 441-4237

E-mail: [cardinal@cardet.com](mailto:cardinal@cardet.com)

203 E. Daugherty  
Webb City, MO 64870

12/11

Printed in USA

315-WARRANTY-CAR-H

