

MACWORLD

February 1985 \$4.00
Canada \$4.75

The Macintosh™ Magazine

Laser!

Will Apple's new laser printer
be the key that opens corporate
doors to the Mac?



**Mac on the
Audit Trail**

**Clean Up Your
Desk with
Factfinder**

**Tips for Mac
Graphic Design**

Move Into MacStation™!

It's two walls and a roof where every Macintosh should live.

With plenty of storage space for a printer, disk drive, modem and manuals.

And a place your pet mouse can hide!

It's MacStation. An integrated workstation that's at home in offices, dorm rooms or dens. And a terrific way to save valuable desk-top real estate.

Adjustable shelves let you rearrange the rooms the way you like.

The roof doubles as a handy printer stand. With attic space to store continuous form paper.

Plus MacStation is ventilated. To keep Macintosh cool. And with the large front door, you can easily take Mac out for a walk.

You don't have to mortgage your house to buy one, either. Because you can get MacStation for only \$95* at your favorite Apple store.

Give your Macintosh a good home!

For more information call:

1-800-547-4000, Dept. 410

(In Oregon or outside USA:

Call 1-503-684-3000, Dept. 410)

MicroRain™

*This is our suggested retail price. MicroRain's 2000 dealers nationwide set the actual selling price. Apple is a registered trademark and Macintosh a trademark licensed to Apple Computer, Inc.

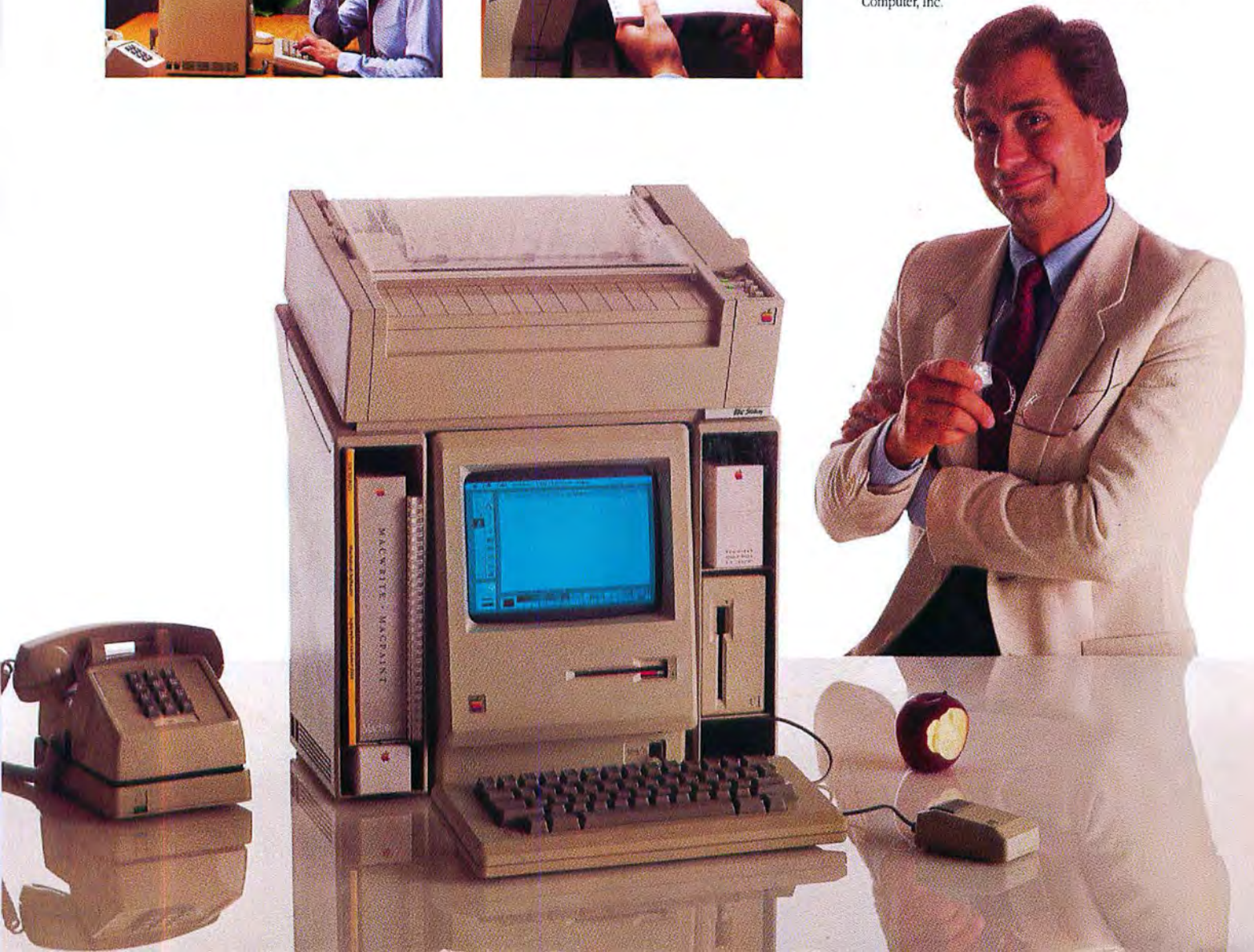

Tecmar Sweetens Macintosh® with Hard Disk Power

Mac Drive™

Tecmar's Mac Drive gives you a 10 megabyte fixed hard disk or a 5 megabyte removable hard disk. You can add a 5 megabyte removable hard disk to either of the above.

With Tecmar's Mac Drive . . .

- Your Macintosh runs much faster than with the built-in floppy.
- Mac Drive will provide up to 38 times more storage than floppies.
- You can minimize the use of floppies.
- You can access files and save time by loading programs from Mac Drive.
- You can take your removable Mac Drive cartridge with you for added security.



TECMAR
Tecmar Sweetens Apples™

Tecmar Inc. 6225 Cochran Road Solon (Cleveland), Ohio 44139-3377 Phone:(216)349-0600 Telex: 466692

MACWORLD

February 1985

The Macintosh™ Magazine

Getting Started

44 A Face for All Seasons

James Felici and Evelyn Spire

An introduction to the world of typography, including a close look at the LaserWriter's high-quality typefaces.

57 Get Info

Lon Poole

Macworld's tutor answers questions from readers about the Mac.

Review

70 The Laser's Edge

Danny Goodman

Just as the Macintosh redefined personal computing, Apple's LaserWriter printer will redefine the way business and professional people produce printed output.

84 Just the Facts

Bill Groat

Factfinder's free-form filing system lets you keep the desk clutter out of sight while keeping facts within reach.

95 Macware News

Edited by Erfert Nielson

Announcements of the latest developments in Macintosh software, hardware, and accessories.



State of the Art

106 The Language that Talks to Your Printer

Richard Sprague

PostScript, the revolutionary programming language that the LaserWriter uses to create professional-looking text and graphics, promises to become the industry standard for producing high-resolution output.

Photo/illustration credits

Adobe Systems, 45; American Type Founders Co., 49; John Hersey, 34, 36, 85-87; Ed Kasbi, 106-107, 150-160; George Steinmetz, 9, 15, 35, 37, 57; Fred Stimson, cover, 71-75, 122-123.

Printing technology has come a long way from blocks of type set by hand, but the centuries-old traditions of quality and readability have remained. Find out how the LaserWriter laser printer, with a built-in computer that has four times as much memory as the 512K Macintosh, carries on those traditions in "A Face for All Seasons," beginning on page 44.

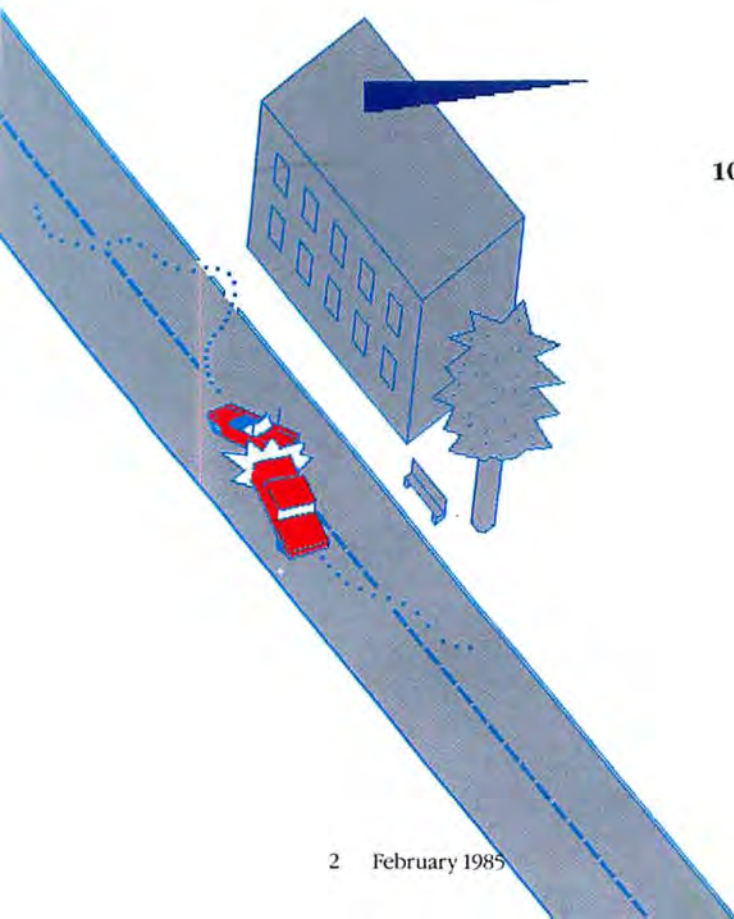

Hands On

122 **The Elements of Graphic Design**

Edited by Bill Grout

An interview with *Macworld's* designer reveals some basic strategies for helping you communicate visual information effectively.

138 **Open Window**

Edited by Daniel Farber

An exchange of Macintosh discoveries.

Community

150 **Mac on the Audit Trail**

Steve Mann

The saga of how Peat Marwick, one of the world's largest auditing firms, is changing the way accountants do business.

166 **Macworld Gallery**

Edited by Erfert Nielson

An exhibition of Macintosh graphics, including a first-prize winner with two entries.

Columns

9 **A Call to the First Mac Tribal Gathering**

David Bunnell

15 **From Milestone to Cornerstone**

Kearney Rietmann

21 **Letters**

34 **Macworld View**

Edited by Janet McCandless

How to get *MacPaint* on your clothes and other news and notes for the Macintosh community.

Indexes

175 **Products**

176 **Advertisers**



Can you picture these people wearing green visors? Auditors face an innovative future in a profession that isn't known for radically new developments. Starting on page 150, read about a computerized auditing system based on Macintosh hardware and software that prefigures an end to auditing as usual.



MACWORLD

Editorial

Editor-in-Chief: Andrew Fluegelman
Editor: Kearney Rietmann
Associate Editor: Daniel Farber
Assistant Editor: Adrian Mello
Editorial Manager:
Janet McCandless
Editorial Assistant: Erfert Nielson
Copy Editors: J. E. Arcellana, Joe Matazzoni, Evelyn Spire
Assistant to the Editors:
Heidi Mitchell
Contributing Editors:
Danny Goodman, Gordon McComb, Lon Poole, Jeffrey S. Young

Art

Associate Publisher:
Jacqueline Poitier
Designer: Marjorie Spiegelman
Associate Designer: Dennis McLeod
Art Director: Bruce Charonnat
Design Associates: Leslie Barton, Holly Douglas, Donna Sharee, Molly Windsor-McLeod
Assistant to the Art Director:
Nan Cassidy

Production

Production Director:
Herbert Linden
Senior Production Manager:
Frances Mann
Production Manager: Lee R. Trevino
Editorial Production Manager:
Ellyn L. Hament
Production Editor: James Felici
Ad Traffic Coordinator: Jayne Boyer
Telecommunicators: Mark L. Duran, Susan M. Ford, Len W. Shirts
Production Assistant: Otto Waldorf

Publishing

Publisher: David Bunnell
Special Projects: Susan Keller
Communications: Noreen A. Browning
International: Karen Dowell
Assistants: Randi Glaser, Jeffrey S. Glines

Sales

Director of Advertising Sales and Marketing:
Jim Martin
National Sales Manager; Western Regional Manager:
Penny Rigby
Regional Account Manager:
Vincent Ivey
Northeast Regional Manager:
Lisa Kunin
Marketing Services Manager:
Charles Abrams
Sales Assistant: Cathy Miller

Circulation

Circulation Director: Penny Ertelt
Director Single Copy Sales:
George Clark
Single Copy Sales Manager: Bill Cox
Dealer Sales Manager:
Mary Ruth Kristoff
Fulfillment Manager:
Russell D. Smith
Promotions Manager: Laurie King

Administration

Director: Janet McGinnis
Accounting Manager: Pat Murphy
Facilities Manager:
Joseph Wollenweber
Personnel Manager: Sarah Cox
Assistant to the President:
Christina W. Spence

Corporate

PC World Communications, Inc.

David Bunnell

Chairman

Bartlett R. Rhoades

President & CEO

Andrew Fluegelman

Vice President

Herbert Linden

Vice President

Jacqueline Poitier

Vice President

Cheryl Woodard

Vice President

Volume 2, Number 2

February 1985

Macworld™ (ISSN 0741-8647) is published monthly by PC World Communications, Inc., 555 De Haro St., San Francisco, CA 94107. Subscription rates for the U.S. and Canada are \$30 for 12 issues, \$50 for 24 issues, and \$70 for 36 issues. Canadian orders must be paid in U.S. funds. Outside the U.S. and Canada subscriptions must be prepaid in U.S. funds with additional postage at \$12 per 12 issues for surface mail or \$60 per 12 issues for airmail. For subscriber service questions call 800-247-5470 (in Iowa 800-532-1272) or write: Subscriber Services, PO Box 20300, Bergenfield, NJ 07621. Application to mail at Second Class pending at San Francisco. POSTMASTER: Send address changes to *Macworld*, PO Box 20300, Bergenfield, NJ 07621.

Editorial and business offices: 555 De Haro St., San Francisco, CA 94107. 415/861-3861.

Macworld is a publication of PC World Communications, Inc.

Macworld is an independent journal, not affiliated in any way with Apple Computer, Inc.

Apple is a registered trademark of Apple Computer, Inc. Macintosh is a trademark licensed to Apple Computer, Inc.

The following are trademarks of PC World Communications, Inc.: Note Pad, Macware News, Open Window, Macworld Gallery, Macworld View. *Macworld* is a member of the CW Communications/Inc. group, the world's largest publisher of computer-related information. The group publishes 55 computer publications in 24 major countries. Nine million people read one or more of the group's publications each month. Members of the publication group include Argentina: *Computerworld/ Argentina*; Asia: *The Asian Computerworld*; Australia: *Computerworld Australia*, *Australian Micro Computerworld Magazine*, *Australian PC World and Directories*; Brazil: *DataNews*, *MicroMundo*; China: *China Computerworld*; Denmark: *Computerworld/ Danmark*, *MicroVerden*; Finland: *Mikro*; France: *Le Monde Informatique*, *Golden* (Apple), *OPC* (IBM); Germany: *Computerwoche*, *Microcomputerwelt*, *PC Welt*, *Software Market*, *CW Edition/Seminar*, *Computer Business*, *Commodore Magazine*; Italy: *Computerworld Italia*; Japan: *Computerworld Japan*, *Perso ComWorld*; Mexico: *Computerworld/ Mexico*, *CompuMundo*; Netherlands: *CW Benelux*, *Micro-Info*; Norway: *Computerworld Norge*, *MikroData*; Saudi Arabia: *Saudi Computerworld*; Spain: *Computerworld/España*, *MicroSistemas*; Sweden: *ComputerSveden*, *MikroDatorn*, *Min Hemdator*, *Svenska PC World*; United Kingdom: *Computer Management*, *Computer News*, *Computer Business Europe*; United States: *Computerworld*, *Hot CoCo*, *In-Cider*, *InfoWorld*, jr., *Macworld*, *Micro Marketworld*, *Microcomputing*, *PC World*, *PCjr World*, *Rim*, 73 *Magazine*, 80-*Micro*.

Printed in the United States of America.
Copyright ©1985 PC World Communications, Inc.
All rights reserved.



No bottom to the apple barrel!



NEW
LOW PRICE
ON 5.5MB:
\$1495
and 10MB:
\$1995

Corvus OmniDrive™ gives you unlimited file capacity.*

Add a Corvus OmniDrive to your Macintosh™ and unleash the full potential of this amazing new Apple computer.

More Capacity. Take file capacity for example. Put the Macintosh Finder program to work with the vastly increased storage capacity of a Corvus OmniDrive. Now you can set up many more volumes with 128 Macintosh files in each one. Need more capacity? Add another OmniDrive, then another, and another, up to a total of eight. Total capacity using 45 MB OmniDrives is 14,336 files.

Faster. OmniDrive is faster too—50% faster than competitive hard disks, three-times faster than the Mac Floppy.

Mac Compatible. We didn't modify the Mac operating system, we work with it. You don't sacrifice any of Mac's famed user friendliness.

Network Ready. With OmniDrive, you're all set to expand to a network. As your business grows and you need more computers, don't hesitate. OmniDrive is network ready, ready to connect more than 60 Macs on the Corvus Omninet network, the world's most widely used network for personal computers.

Full Service and Support. Corvus is the world's most experienced supplier of Winchester disks and pc networks. We have delivered over 35,000 hard disks and connected more than 115,000 computers on 14,000 Corvus networks worldwide. We provide the kind of support and service that assures protection for your investment now and in the future.

Lowest Cost. The best news of all is the price: \$1,795 for the 5.5 MB model. That's less than the competition, and most can't touch the capacity, versatility, or performance that Corvus offers.

Get a Demonstration. Contact your nearest Corvus or Apple dealer today. Ask for a free demonstration of the Corvus OmniDrive and find out how much better your Macintosh can be.

**CORVUS**

Corvus Systems, Inc.
2100 Corvus Drive, San Jose, CA 95124
(408) 559-7000 Telex 278976

*Up to 14,336 files compared to 128 on the Mac Floppy. OmniDrive™ is a trademark of Corvus Inc. Macintosh™ is a trademark of Apple Computer, Inc.

Then draw your Find the

Microsoft® Multiplan® and Microsoft Chart. They're crackerjack programs working on their own. But you should see this pair in action together on the Macintosh.™

The one, a spreadsheet of dazzling analytical power and graceful simplicity.

The other, a picture perfect charting program that makes rows and columns of numbers graphically clear.

And the beauty is, they were literally made for each other. And for Macintosh.

Multiplan accepts you as you are.

Multiplan takes full advantage of Mac's simple, intuitive operating style. So you can work in a way that will come natural to you.

You don't have to memorize any arcane commands. Just point and click the mouse to move mountains of figures and formulas quickly and painlessly.

In addition, Multiplan gives you features that make hard copies gratifyingly readable. For instance, the enviable ability to print sideways.

So you can't run out of column room. No matter how wide your spreadsheet gets.

Chart makes people see what you mean.

Microsoft Chart gives you lots of ammunition for your arguments: Pie charts, bar charts, line, column, area and scatter charts. Or combinations.

MICROSOFT Pick the one that best illustrates your point. Then translate your numbers into pictures and have them on paper in a matter of moments.

The High Performance Software™

Using the mouse, it's a cinch to fine tune the graphs to get exactly what you want. Move any section. Change its size, shape, or highlight it.

Chart can even be linked with Multiplan. So any change on your spreadsheet will show up automatically on the charts.

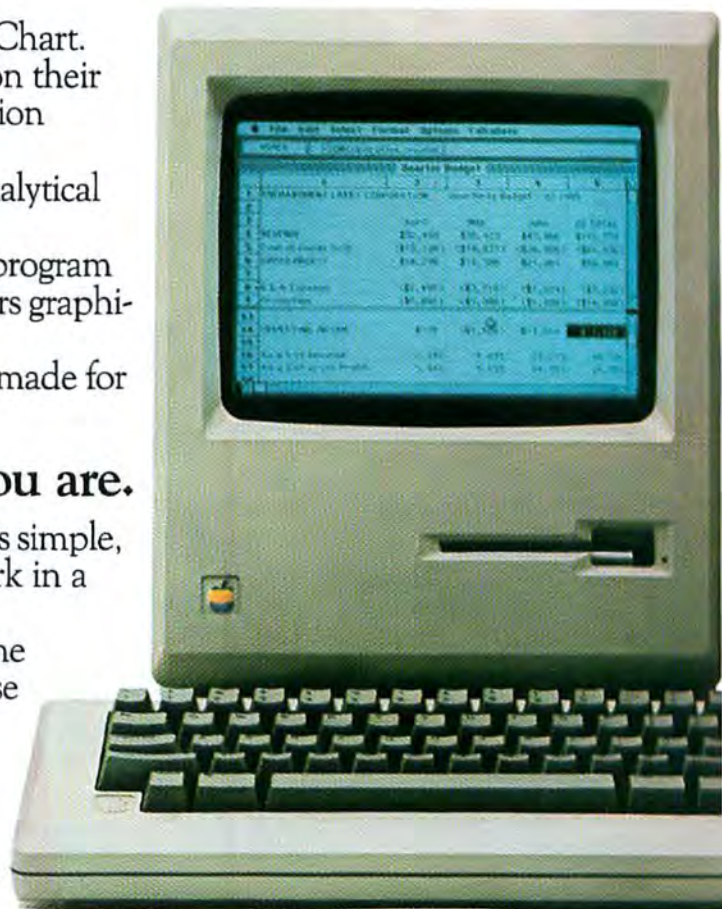

answer. own conclusions.

We get the max out of Mac.

It figures that we'd be the ones to make Mac work so well with figures. We've written more Macintosh programs than any other software company. Including Microsoft Word, Microsoft File. And Microsoft BASIC, Mac's first language.

That experience shows in programs which not only exploit all of Mac's unique features, but make it extraordinarily capable and productive.

In addition, all of Microsoft's Macintosh products can exchange data with each other.

And because our programs work alike, if you learn one, you're

well on your way to learning the rest.

To find the name of your nearest Microsoft dealer, call (800) 426-9400. In Washington State, Alaska, Hawaii and Canada, call (206) 828-8088.

Then check out Multiplan and Microsoft Chart. And watch them perform some nice little numbers.

Microsoft and Multiplan are registered trademarks and The High Performance Software is a trademark of Microsoft Corporation. Macintosh is a trademark licensed to Apple Computer, Inc.



Take us for a ride.

Push, pull, drag or tow yourself to your authorized Apple dealer. And for \$4.95, he'll give you a sample of the highest-performance database program a Mac can handle.

The amazing OverVUE™ information manager. It zips through 1,000 lines of data in 2 seconds flat. Sorts. Analyzes. Categorizes. Extracts. Even calculates. To turn any heap of

raw facts into meaningful information.

Even the handling is impressive. Because OverVUE handles data as easily as MacWrite handles words.

So visit your dealer now. Get your hands on that OverVUE demo disk.

And take it out for a spin. **OverVUE™**

ProVUE Development Corporation, 222 22nd Street,
Huntington Beach, CA 92648 • (714) 969-2431



Circle 72 on reader service card

©1984 ProVUE Development Corporation. Apple and MacWrite are trademarks of Apple Computer, Inc. Macintosh is a trademark licensed to Apple Computer, Inc. ProVUE and OverVUE are trademarks of ProVUE Development Corporation.

A Call to the First Mac Tribal Gathering



The Macintosh revolution is not based only on a particular piece of computer hardware that happens to represent a new stage in personal computing. And it is not merely a reaction to a few startling TV commercials. The revolution stems from how you use the Macintosh and how it affects your work. The Macintosh revolution is in you.

As a Macintosh user you not only represent a dynamic subculture—you are part of a significant stage in personal computing evolution and able to help shape the future of the industry. The timing couldn't be better for you to voice your opinions on how personal computers should work.

For these reasons, we have decided to call the first convention of Macintosh users and product suppliers. I don't normally write columns to promote events we sponsor, but I am anxious to inform every Mac owner about the impact of this trade show and the opportunities to learn and explore the different facets of the Macintosh age. The Macworld Ex-

position will set a new standard in computer shows. Guaranteed to be more than the average consumer trade show, it will be an extremely important gathering of the Macintosh tribe.

The first Macworld Exposition will be held February 21-23, a little over a year after the Mac's introduction, in San Francisco, the beautiful city that is our home. With Silicon Valley and Apple Computer next door, we decided there was no better place to have the show. And what could be more appropriate than holding the expo at Brooks Hall, where the Apple II was introduced at Jim Warren's original West Coast Computer Faire in 1978.

Most companies that advertise in *Macworld*—including Apple—have already reserved exhibit space at the show, so there will be an abundance of Macintosh software and hardware. The Macworld Expo will have clusters of Macs on the exhibit floor to give you the opportunity to test-drive impressive new software. Seminars and panel discussions will also be available for users, software authors, and others in the Macintosh industry.

These three days in February will allow you to get involved with the Macintosh to a degree that's never been achieved be-

fore. Among the seminars will be How to Start a Business with Your Macintosh, Maximizing MacWrite, Unveiling the Mac's Hidden Features, Data Base Management with the Mac, Local Area Networks, What's Available in Mac Software, and Maximizing MacPaint. For potential software authors, we have special programs on topics such as MacPascal and MacBASIC, How to Write Friendly Mac Software, How to Get Your Programs Published, How to Become a Wizard at Machine Language Programming, and as a special enticement, A Complete Technical Guide to How the Macintosh Works. Combined with a chance to meet some of the original Macintosh software developers and a few members of the famous Macintosh team from Apple, these seminars could change your approach to programming.

Whether or not you can attend, the expo represents your chance as a Mac user not only to learn about the Macintosh and maximize its usefulness, but also to help influence future Macintosh development. Every company exhibiting at the Macworld Expo will be extremely interested in your opin-

David Bunnell

ions; your endorsement or rejection of their products and ideas could have an enormous impact on their revisions. As early users, most of you will have many opportunities to influence both hardware and software in the the Macintosh market.

There is no mysterious shroud surrounding the reason for newspapers and business magazines being filled with stories about Apple, IBM, and other major players in the personal computing industry. It's an exciting field with the unparalleled ability to affect the shape of our society and the path of our future. By getting involved in this industry, you help make your own history. So come to San Francisco for the Macworld Expo and experience the great Macintosh revolution. □

*Macworld Exposition
February 21-23, 1985
World Expositions
Mitch Hall Associates
P.O. Box 860
Westwood, MA 02090
617/329-7466*

The C for the Macintosh

AZTEC C68K-C \$499 commercial software development system

• Full Version 7 'C' Compiler • Fast and Compact Code • Linker (overlay) • Resource Editor • No Royalties • Source Editor • Compatible with AZTEC 'C' for PC DOS, CP/M-86, CP/M-80, APPLE II, TRS-80, COMMODORE 64 • 68000 Macro Assembler • Extensive Run Time Support • Utilities • Shell Environment • Requires 128K MACINTOSH • Compatible with LISA MACWORKS and 512 MACINTOSH • Full access to MACINTOSH TOOLBOX (ROM & OS)

AZTEC C68K-P \$199 personal software development system

AZTEC C68K TOOLS \$249 (make, grep, diff, Z editor)

MAC CROSS COMPILER
HOSTS & TARGETS
LISA, PC DOS, MS DOS,
CP/M-80, APPLE II, VAX,
PDP 11



MANX

TO ORDER OR FOR INFORMATION
CALL OR WRITE:
MANX SOFTWARE SYSTEMS
Box 55
Shrewsbury, NJ 07701
TX 4995812



CALL:
800-221-0440
201-780-4004 (NJ)

Circle 112 on reader service card

The most BASIC.

Microsoft® BASIC is the language spoken by nine out of ten microcomputers worldwide. It's the language with the most programs written for it.

So if you want to access the power of your Macintosh™, only one language makes the most sense. Mac's first language, Microsoft BASIC.

Not only is it the industry standard, it's the most advanced BASIC for Macintosh. It lets you add mouse commands. Graphics. Windows. Change type fonts and styles. Customize menus. Incorporate music and sound effects. Write your own dialog boxes. Basically, it lets you take advantage of everything that makes Mac 'Mac.'

It makes editing programs as easy as cutting and pasting and pointing and clicking. Debugging is easier

than ever with the advanced trace command.

It's no wonder Microsoft is the most logical choice for the Macintosh.

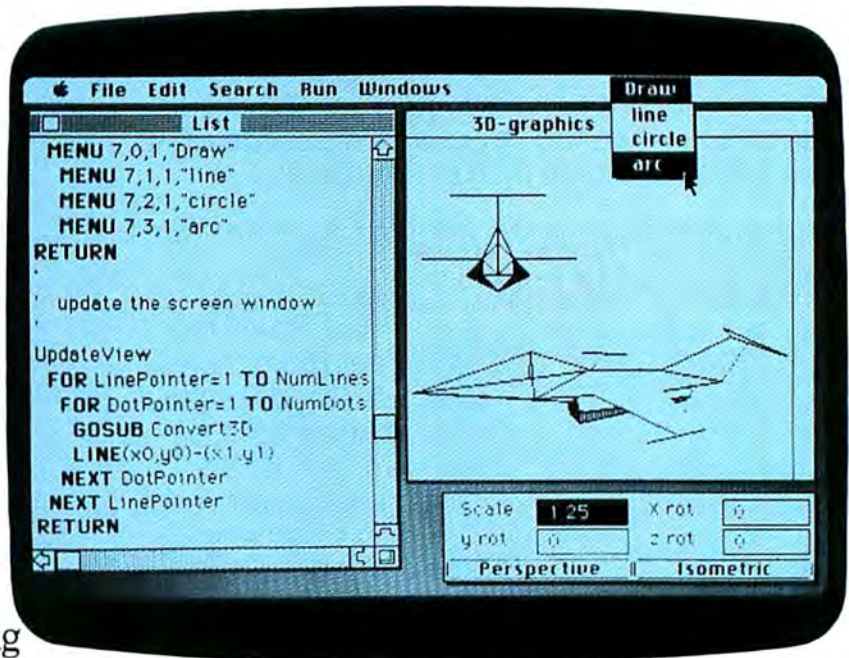

MICROSOFT We've
The High Performance Software written more
Macintosh programs than any other
software company. Including Mac's
spreadsheet, Multiplan®.

So if you want to get the most out of your Macintosh, call (800) 426-9400 for the name of your nearest Microsoft dealer. In Washington State, Alaska, Hawaii and Canada, call (206) 828-8088.

Microsoft and Multiplan are registered trademarks of Microsoft Corporation
Macintosh is a trademark licensed to Apple Computer, Inc.

MICROSOFT

Looking for

INTRODUCING FRONT DESK™ A BETTER WAY TO MAINTAIN SCHEDULES FOR UP TO 15 PEOPLE, PLACES OR THINGS.

Front Desk™ There's nothing else available that lets you see what's available in so many different ways.

It's a better way for dentist offices to keep their doctors ordered. For health clubs to sort their courts. For schools to schedule their A/V equipment. For companies to allocate their conference rooms. Or for accounting firms to keep account of their CPA's.

In short, it's for anyone who has a lot to allot.

It lets you zoom from one person's calendar to the next. Or zip from a monthly view to a weekly view to a single day view for one person or everyone. All as quick as a click. In fact, when you've got a lot of scheduling to do, nothing can make time fly like Front Desk.

SEE THE PAST. THE FUTURE. AND THE BOTTOM LINE.

Services	Fee	Dr. Jekyll	Dr. Hyde	Dr. L.	Dr. M.	Total
1. Initial Exam	50.00	110.00	110.00	110.00	110.00	440.00
2. Single X-Ray	3.00	0.00	0.00	0.00	0.00	0.00
3. Bleaching 9-Nets	8.00	0.00	0.00	0.00	0.00	0.00
4. Composite 1 Surface	25.00	137.50	57.50	117.50	0.00	312.50
5. Prophy	26.00	52.00	140.00	0.00	0.00	192.00
6. Extract Single Tooth	40.00	76.00	0.00	0.00	0.00	116.00
7. Amalgam/Alive	23.00	588.00	334.00	0.00	0.00	922.00
8. Pulp Cap	15.00	0.00	0.00	1,483.00	0.00	1,498.00
9. Root Canal	95.00	1,200.00	280.00	0.00	0.00	1,475.00
10. Crown, Part. & Gold	75.00	375.00	1,875.00	0.00	0.00	2,250.00
11. Crown, Full Gold	140.00	280.00	2,740.00	1,160.00	0.00	4,180.00
12. Crown, Temporary	40.00	140.00	740.00	444.00	92.00	1,316.00
13. Non-Billable	0.00	0.00	0.00	0.00	0.00	0.00
Total Billing		4,371.00	10,729.00	3,747.00	2,096.00	20,943.00

But Front Desk does more than just let you organize how time is spent. It also gives you powerful tools that let you see how well time is spent.

It remembers what services are performed by each staff member during any particular time period.

So in the click of a mouse you can create a report for last month showing how many hours each dentist in your office spent—or how many dollars they brought in—by cleaning teeth, or filling cavities, or whatever. And you can project how much money each dentist will bring in on those services in the next two weeks or two months. This not only helps you improve the way your cash flows, it helps you make more of it.

LET THE GOOD TIMES SCROLL.

Whether you're scheduling activities for an architect, or engagements for an engineer, a flick of your finger will call up that person's full day calendar, which is preset in whatever time intervals you

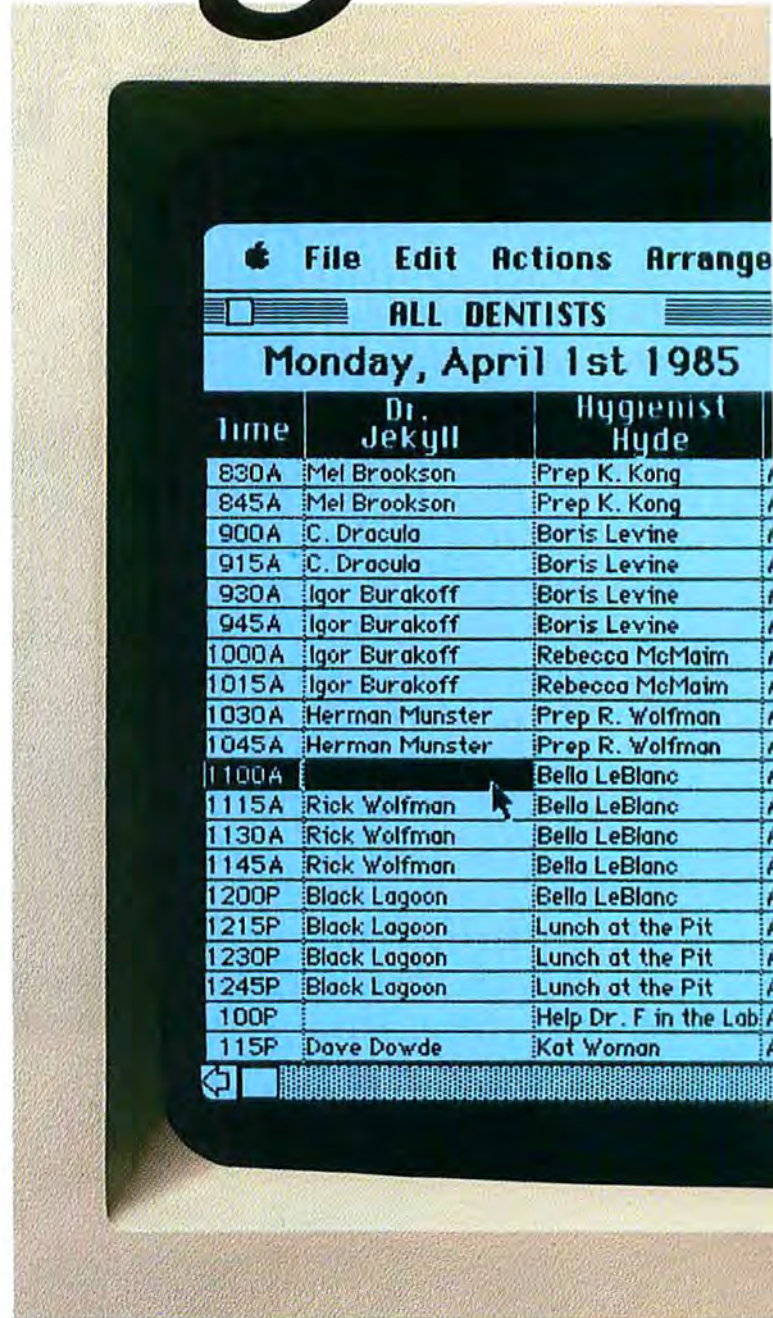

© 1984 Layered, Inc.

Time	Name	Phone	Service	Comment	Am't
830A	Mel Brookson	572-3333	Exam	Prep	204.45
845A	Mel Brookson	572-3333	Exam	Prep	204.45
900A	C. Dracula	392-0090			
915A	C. Dracula				
930A	Igor Burakoff	525-1186	Trackball	Est for Referrals	2,000
945A	Igor Burakoff				
1000A	Igor Burakoff				
1015A	Igor Burakoff				
1030A	Herman Munster	437-7000	Management	Dental Exam, Injection	00
1045A	Herman Munster				
1115A	Rick Wolfman	525-1575	Examination	Checked & Instruct	125.00
1130A	Rick Wolfman				
1145A	Rick Wolfman				
1200P	Black Lagoon/Phy. Dept	00	Exam		
1215P	Black Lagoon/Phy. Dept				
1230P	Black Lagoon/Phy. Dept				
1245P	Black Lagoon/Phy. Dept				
100P	Rick Wolfman/Phy. Dept				
115P	Dave Dowde	576-5612	Follow	Cavities & Bridge work	150.00

choose. Use the side scroll bar to view the entire day's schedule. Or the bottom scroll bar to see the previous or next day.

a good time?

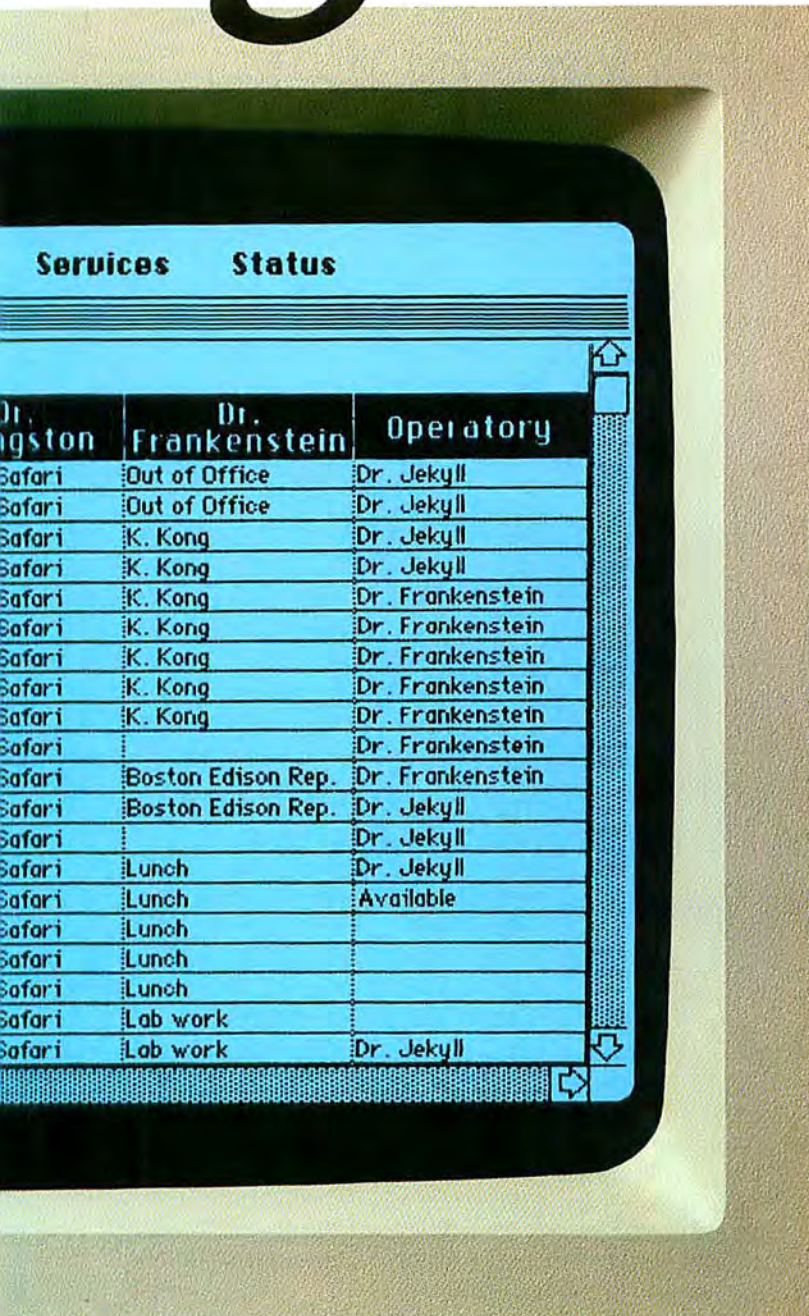

amazing is that when someone tells you "I'm only available on Tuesdays," a single view of all Tuesdays in April is just a click away.

GET THE BIG PICTURE.

Front Desk not only lets you select the calendar of any one particular dentist, racquetball court, or company fleet car, it lets you select a composite view of every schedule.

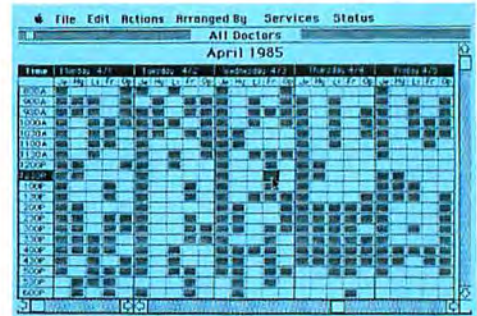

By scanning the columns under the initials you can spot every available opening in an instant. And because you can see everyone's calendars in one view, scheduling internal meetings is a snap.

HOW TO PUT PEOPLE IN THEIR PLACE.

Once you find an open time slot, double-click to call up an appointment entry form. Fill it in, click save and the information is recorded on the calendar.

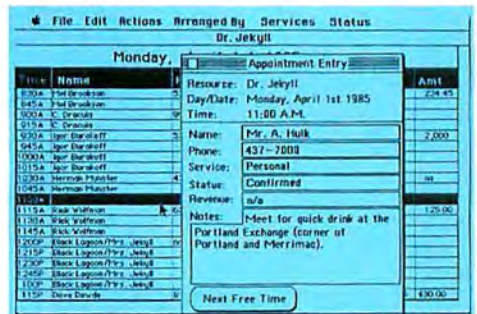

Plus you can cut or copy and paste information from any time slot to rearrange schedules in seconds. And print out copies of any view of any calendar at any time.

DON'T WASTE ANOTHER DAY.

Cancel your next appointment and rush down to your computer store.

And tell them you're looking for a good time.



Layered Incorporated 85 Merrimac St.
Boston, MA 02114 (617) 423-9041

SEE A MONTH OF SUNDAYS.

Tap your mouse and Front Desk will put a whole week of appointments on the screen at once. But what's really



Circle 125 on reader service card

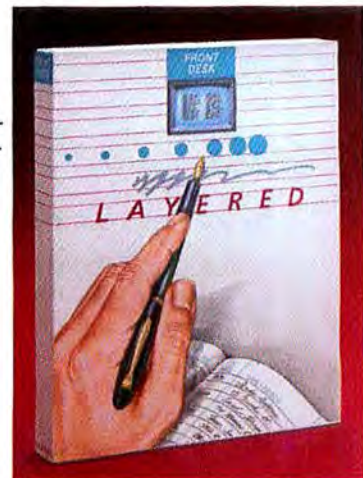

Now there's ^{more} Dow Jones Software™ for the Macintosh™ computer.

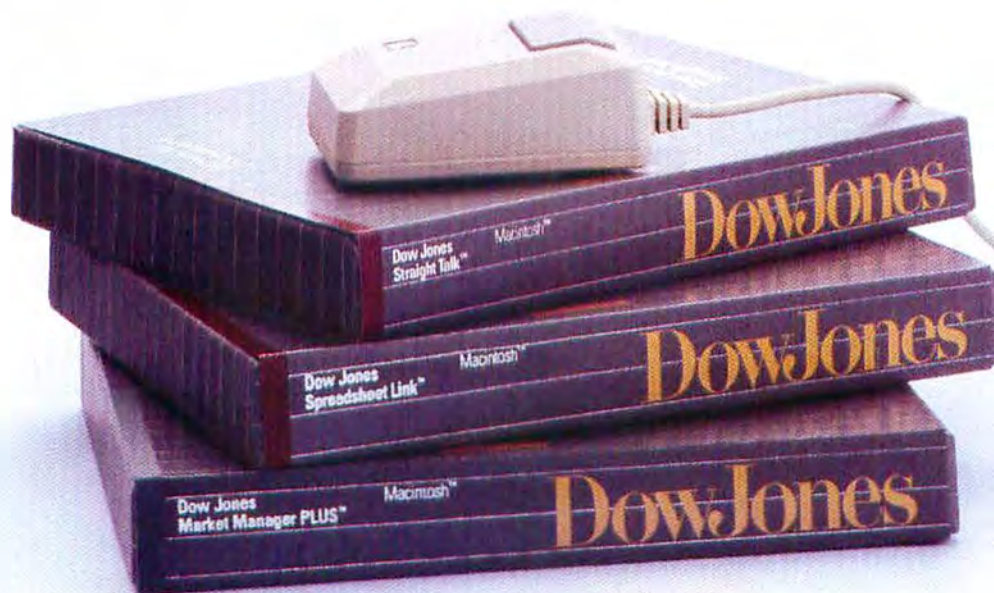

In the beginning there was Dow Jones Straight Talk.™

All across the country, Macintosh™ computers – and their owners – are getting smart with just the information they need: an electronic encyclopedia, business news and information, the latest stock quotes, sports and weather reports, airline schedules and fares. Point, click, Dow Jones News/Retrieval® and other leading electronic information services are at your fingertips.

In fact so many Macintosh computers are getting smart that Straight Talk is a best seller.

Now there's more.

Introducing Dow Jones Spreadsheet Link™ and Dow Jones Market Manager PLUS™ – new software for the Macintosh computer.

Dow Jones Spreadsheet Link adds brainpower to your Multiplan® spreadsheet. Just collect the financial information you need from News/Retrieval and – click – Spreadsheet Link automatically downloads it into your spreadsheet.

Dow Jones Market Manager PLUS makes portfolio management as easy as using a mouse. With current stock price information from News/Retrieval, the Market Manager PLUS saves time in record keeping, giving you more time to make smart investment decisions.

Call for more information on Dow Jones Software™ for the Macintosh computer:

1-800-345-8500 ext. 100

(Alaska, Hawaii, and foreign, call 1-215-789-7008 ext. 100)

Dow Jones Software™

Macintosh is a trademark licensed to Apple Computer, Inc. Multiplan is a registered trademark of Microsoft Corporation. Dow Jones Software is a trademark of Dow Jones & Company, Inc. Dow Jones Straight Talk is a trademark of Dow Jones & Company, Inc. Dow Jones News/Retrieval is a registered trademark of Dow Jones & Company, Inc. Dow Jones Spreadsheet Link is a trademark of Dow Jones & Company, Inc. Dow Jones Market Manager PLUS is a trademark of Dow Jones & Company, Inc. Copyright ©1984 Dow Jones & Company, Inc. All Rights Reserved.

Circle 69 on reader service card

From Milestone to Cornerstone



As the novelty of the Macintosh begins to wear off, its owners are wondering if the computer is a milestone or a cornerstone. If the Mac is only a milestone, technology may pass it by. Like the Osborne portable, milestone computers sometimes become millstones too heavy to carry around.

The Macintosh was introduced in 1984 with all the ceremony of a cornerstone-laying. But with the oratory over, it's time for the building to go up. In 1985, a series of new Apple products is creating the superstructure for the Macintosh office. The series includes the LaserWriter printer, the AppleTalk Personal Network and related products, and a file server. The Macintosh office is designed for groups of people who work together in small businesses, corporations, and universities. The products link individual Macs together in a network. Computers in the network share printers, storage devices, and other hardware. They also exchange information in the form of messages or data from shared data bases.

The first available Macintosh office product is the LaserWriter laser printer. The printer brings high-quality printing to people who produce Macintosh text and graphics. Because output from the LaserWriter approaches the typeset quality of

books and magazines, professionals—from writers and graphic designers to insurance agents and financial planners—can produce camera-ready art, technical documentation, or even tax return forms.

Like the 512K Macintosh, the LaserWriter price tag is high—\$7000. But to justify the cost, Apple has designed the printer to be shared via the AppleTalk network cable and connectors. To find out more about the LaserWriter, read Danny Goodman's preview, "The Laser's Edge," in this issue. Goodman's article and two others in the issue—"A Face for All Seasons" and "The Language that Talks to Your Printer"—should give you the background you need to judge if the LaserWriter is right for you.

The AppleTalk network connects as many as 32 pieces of hardware in configurations that include Macs, printers, and file servers. Persons on the network can share hardware and exchange information. The file server is like an electronic filing cabinet in which you keep messages, programs, and data bases.

One component planned for the network is a circuit board developed by Apple for the IBM Personal Computer. When installed in the IBM PC, this hardware will enable people who own both PCs and Macintoshes to share the LaserWriter and the Macintosh file server. Set-

ting up a scheme for exchanging information such as spreadsheet data or word processing documents between two computers as different as the IBM PC and the Macintosh is complicated, and sophisticated software will have to be developed to completely link the two computers. But if Apple makes such communication possible with Macintosh-style ease of use, the company will have indeed developed a brilliant product. A well-implemented Mac-PC link will be worth waiting for.

But waiting is the question. Macintosh owners spent most of 1984 waiting for new software and hardware to build on the foundation laid by the new computer. Many of us grew impatient with unfulfilled promises. Although the LaserWriter is available now, we have to wait until late spring or early summer for the file server and electronic mail software. The circuit board for the IBM PC is scheduled for even later. It remains to be seen if people will accept Apple's step-by-step approach to building the Macintosh office. If we don't have to wait too long for all the products to be put in place, the Macintosh office concept may become a cornerstone in office automation. □

NOW MACINTOSH USERS CAN GET LETTER-QUALITY PRINTING.



Introducing the Spinwriter/Macintosh connection.

There are times when even a Macintosh™ user doesn't want printing that looks like it came from a computer. Important business letters. A make-or-break presentation. A resume. A legal brief.



Works with Spinwriter printers 2010, 3510 and 8810.

Now Macintosh users can have genuine letter-quality printing. And not just ordinary letter-quality but Spinwriter® letter-quality

Apple is a trademark of Apple Computer, Inc., Macintosh is a trademark licensed to Apple Computer, Inc. Spinwriter is a registered trademark of NEC Corp.

printing. With NEC's new accessory kit for the Apple™ Macintosh.

Which consists of a diskette (plus a backup), an interface cable and a manual. This easy-to-use package lets you control printing on your Spinwriter with your mouse.

Spinwriter printers have unique capabilities.

You can do more things with a Spinwriter and your Macintosh than other letter-quality printers. Like use our more than 80 different type styles. Or print in a foreign language. Or have proportional spacing.

You can also use a variety of NEC-designed and made paper handlers which let you do such things as address envelopes automatically, right along with your letters.

Spinwriter printers also last a long time. In fact, their record for quality and

reliability is unmatched. And survey after survey shows they are the preferred letter-quality printer of personal computer owners. **See your computer dealer, now.**

Ask for a Spinwriter printer demo and see what it can do for your Macintosh. Or for more information call 1-800-343-4419; in MA call (617) 264-8635.

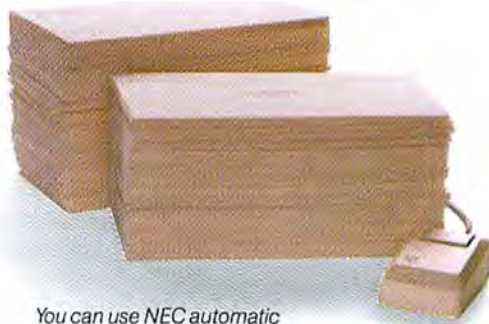

You can use NEC automatic paper-handlers with the mouse.

Find out why more and more Apple users are saying, "NEC and me."

Yes! Please send me more information on:

Spinwriter 2010
 Spinwriter 3510
 Spinwriter 8810
 Spinwriter/Macintosh connection

Name _____
 Title _____
 Company _____
 Address _____
 City _____
 State _____ Zip _____

NEC Information Systems, Inc., Dept. 1610, MW2
 1414 Massachusetts Avenue, Boxborough, MA 01719

NEC

NEC Information Systems, Inc.

Circle 142 on reader service card

Microsoft played an integral role in the development of the Macintosh. It has our brains and a lot of our personality. Here are the first titles in the MacBook Library from Microsoft Press.

MacWork/MacPlay

Lon Poole

MacWork/MacPlay is a gallery of ideas for home and business on the personable Macintosh. Lon Poole, author of the popular *Apple II User's Guide* and "Get Info" columnist for *MacWorld*, brings you 24 original projects for using the Mac's most popular application software: MacWrite, MacPaint and Microsoft Multiplan. Practical...inventive...and loads of fun.

\$18.95



Presentation Graphics on the Apple® Macintosh™

Steve Lambert

A step-by-step guide to using Microsoft's extraordinary Chart program. Even if you have no previous computer or graphics experience, you can create dazzling presentation graphics for corporate and professional use in a matter of only minutes.

\$18.95

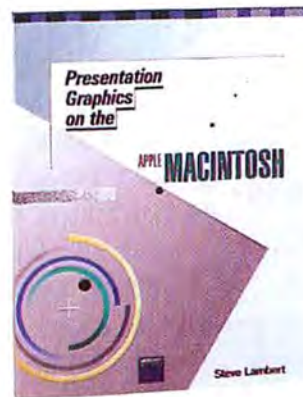

The Apple® Macintosh™ Book

Cary Lu

Cary Lu observed the creation of the Mac first-hand and takes you behind the scenes with this comprehensive guide to how the Mac and its software work. You see exactly what you get—all in the friendly, visual style of the Mac itself. A unique insider's view of this historic advance in computer technology.

\$18.95



Microsoft Press 10700 Northup Way Bellevue, WA 98004



Available wherever fine books are sold.

How to bring out the



Out of respect for your unbridled love of the Macintosh (and ours, too), we've created even more insanely wonderful ways to enhance its remarkable performance. With five easy-to-use, useful and totally captivating tools that take full advantage of the Macintosh's incredible capabilities. All designed to the Macintosh's high standards for quality and reliability. Priced to please the most discriminating Macintosh lover.

Mac·Daisywheel·Connection™

Now, with the Mac·Daisywheel·Connection, your Macintosh can print with any popular daisywheel letter-quality printer. Like the Apple Daisywheel Printer, the Brother (HR Series), the C-Itoh (Starwriter), the Daisywriter, the Diablo, the NEC Spinwriter, and the Qume (Letterpro and Sprint II Series) — just to name a few.

The Mac·Daisywheel·Connection gives you complete flexibility. You can keep your daisywheel and dot matrix printers connected

to your Macintosh at all times. Just point and click to the printer you want to use.

The Mac·Daisywheel·Connection is ideal for business correspondence, reports, legal documents and even spreadsheets. It lets you print a full 15" paper width. It comes complete with a program disk, a quick start-up guide and an interface cable. List price \$99.

Mac·Spell·Right™

With Mac·Spell·Right, you can easily eliminate all the woes associated with checking and correcting spelling. This powerful new application program automatically does the work for you. Get the power of Webster's Dictionary and Roget's Thesaurus with the click of a button. Because Mac·Spell·Right works directly within MacWrite™ and runs transparently while you work, you never have to switch back and forth between disks and programs.

Think of how your productivity will improve. It won't take nearly as long to check and edit documents once you add "Spell✓" to the MacWrite menu bar.



And you may even find yourself with a little extra time on your hands to expand your vocabulary. Mac·Spell·Right gives you alternate word choices, too.

List price \$89.

Mac·Epson·Connection™

Thanks to the Mac·Epson·Connection, you can now use Epson dot matrix printers with your Macintosh.* Our new driver for high quality dot matrix printers will drive you wild, especially when you see how graphic



~~er~~
~~drive~~
~~silicon~~
~~Processor~~
~~delete~~
~~modern~~
~~cursor~~
~~Rite~~
~~Write~~
~~click~~

best in your Macintosh™



your graphics look and how professional your texts look. Nothing could be simpler or faster (at 160 characters per second). And it takes only 30 seconds to transfer the software to your 3½" diskettes or hard disks.

The Mac·Epson·Connection is totally versatile, too. Anything you can print on the Imagewriter™ you can print on an Epson. The Mac·Epson·Connection is compatible with any software that runs between the Macintosh and the Imagewriter.

The Mac·Epson·Connection comes with a program disk, a quick start-up guide and an interface cable. List price \$89.

*The Mac·Epson·Connection supports a wide range of printer models from Epson, including the FX 80 and 100, the RX 80 and 100 and the LQ1500.

Mac·Turbo·Touch™

The Mac·Turbo·Touch is a new high-speed direct input device (or, if you will, a turbocharged "mouse") for your Macintosh. This is not meant to imply that the legendary love affair between mouse and man is over. Rather, for those of you who are ready for something that can respond as quickly as you do, there is now an exciting option. An option that reduces the time it takes to edit a document by 40%. An option that covers the same ground the mouse covers in one-third

the time and in one-fourth the desk space.

What's more, the Mac·Turbo·Touch is always right where you need it whether you're right- or left-handed because you can park it on either side of the keyboard. Where does it plug in? In the mouse port, of course.

Flexibility is only one of its many virtues. Responsive performance is another. The slightest touch of the gyroscopic ball positions the pointer quickly and accurately on the screen. Mac·Turbo·Touch makes MacWrite, MacPaint and any other software work better, faster and more precisely than before. List price \$129.

Mac·Memory·Disk™

The Mac·Memory·Disk lets you access more of the memory in your 512K Macintosh. It makes interaction between software applications ten times faster. It also lets you allocate a portion of the RAM (Random Access Memory) resident in your 512K

Macintosh and treat it like a disk. With the Mac·Memory·Disk, you now have immediate access to more memory. List price \$29.

More For Your Macintosh

These five innovative and fun tools make it easier than ever to get to the heart of your Macintosh. For additional tips on romancing your Macintosh and a demonstration, see your local Apple Computer Dealer. Or call toll-free: 1-800-MAC-5464. In California, toll-free: 1-800-421-0243. In Canada, direct dial: 408-446-0797.



Assimilation Process™

Apple Imagewriter, MacPaint, and MacWrite are trademarks of Apple Computer, Inc. Macintosh is a trademark licensed to Apple Computer. Mac Daisywheel Connection, Mac Epson Connection, Mac Memory Disk, Mac Spell Right and Mac Turbo Touch are trademarks of Assimilation Process. © Assimilation Process 1984.

Circle 110 on reader service card

Maccessories™ make a good thing even better.

The Macintosh™ is easy to use. Maccessories from Kensington Microware make it easier.



First in the Maccessories family of enhancement products is the **Swivel**. A slim swivel base that attaches underneath the Macintosh, making it easier to

reposition the computer. It goes everywhere the Macintosh goes, even inside the carrying case.

The **Surge Suppressor** is a replacement power cord, providing UL listed surge suppression and line noise filtering for the Macintosh. It fits easily into the carrying case, so your Macintosh is protected no matter where you take it.



There are two anti-static **Dust Covers** in the family. One protects your Macintosh and keyboard. The other takes care of your Imagerwriter.



Leave your delicate, intelligent modem at home. The **Portable Modem** is the perfect traveling companion for the Macintosh. It's small, sturdy, battery powered, weighs less than a pound and even has its own carrying case. The Portable Modem operates at 300 baud with any communications software.



The **Control Center**, styled to fit underneath the external disk drive, provides fingertip control over your whole system. There's a master switch to power the whole system on and off, and separate switches for a printer, modem and one auxiliary device. It also protects your whole system from power surges, line noise and static shocks.



The **Universal Printer Stand**, for the Apple® Imagerwriter, also fits most other dot matrix printers. It raises your printer 1½" from the desk at the front and 4½" at the back, an angle that allows you to monitor



your printer's performance more easily. By raising your printer a few inches from the desk, the Universal Printer Stand solves the problem of where to store your paper. Several hundred sheets are accommodated neatly underneath.

The **Disk Case** provides safe storage for 36 Macintosh disks. And it comes with a handy packet of spare disk labels.



There is more to Maccessories than hardware.

Maccessories Professional Type Fonts are styled after the most popular type faces in the advertising and publishing industries, like Times Roman™ and Helvetica™. They give reports a professional look and add a touch of elegance to correspondence. Available in two volumes. Professional Type Fonts For Text contains 16 unique fonts in sizes 12 to 24 point. For Headlines (for the 512K Mac) contains the same fonts in sizes 24 to 72 point.

Maccessories Graphic Accents is a collection of over 250 professional illustrations, covering everything from business to holidays. Use them for reports, newsletters or greeting cards. Graphic Accents are stored in standard MacPaint™ files, so you can adjust them, copy, cut and paste them just like your own illustrations.

Available at Apple dealers everywhere.

**K KENSINGTON™
MICROWARE**

251 Park Avenue South, NY, NY 10010
(212) 475-5200, Tlx: 467383 KML NY

Trademarks: Maccessories/Kensington Microware Ltd.; Apple, Macintosh, Imagerwriter, MacPaint/Apple Computer Inc.; Helvetica, Times Roman/Mergenthaler Linotype Co.; Fonts by Xiphias © 1984 Kensington Microware Ltd.

Circle 11 on reader service card



Letters

MacWrite Update

As a recent letter to you noted, it would be nice if you could indicate when news you carry is probable rather than accomplished. In "The Macintosh Deluxe" [November 1984], you go into great detail about an upgrade of *MacWrite*. I eagerly rushed to my local dealers and even went so far as to insist that they open up the new 128K and 512K machines that they had received to check whether the new *MacWrite* version was, as you had noted, bundled in with the new machines. As I am sure you are well aware, no such upgrade was to be found.

Being in the communication business, I am well aware of the lead time needed to produce a magazine, but it would be helpful if you could indicate an item's expected availability date.

By the way, I am an associate professor of mass communication and feel that the Macintosh is the true communication wonder of my age (47). Your magazine has also contributed immeasurably to my understanding of the machine, its software, and the potential that truly resides in this deceptive tool, and I shall be a subscriber until I can no longer type and see the screen.

Marvin R. Bensman
Germantown, Tennessee

We used a preview version of the upgraded MacWrite when we wrote the 512K Macintosh story. Our information from Apple was that the updated software would be ready for distribution at the time the 512K Mac was announced in September 1984. We apologize if the information we published inconvenienced you.—Ed.

Warranty Worries

Not having grown up with computers, they were an alien world to me. So I spent two years studying and looking at computers and took a computer course. Then I got in line to buy a Macintosh. It arrived in May, and I thought it was everything that Apple promised and then some.

But my enthusiasm waned with the warranty, which ended at about the same time that the Imagewriter's printhead stopped functioning properly. The technician told me the printhead could not be repaired and that it was very rare for a printhead to go bad on any make of printer. He was as flabbergasted as I was to discover that a replacement costs \$136 (printheads for other printers cost from \$30 to \$60).

At considerable expense, I called Apple customer service and got a long-winded dissertation on how one can expect defects no matter how carefully the maker exercises quality control. The Apple representative said that they only had one supplier for the part and that they had no reports of these heads breaking down on a large scale, suggesting I was just unfortunate in getting one that broke.

Anne D. Snyder
Gainesville, Virginia

MacWrite Gets an A

In a letter published in your September/October issue ["MacWrite Flunks Test"], the writer complained that *MacWrite* is not suitable for an extensive word processing project like a Ph.D. thesis. I recently finished using *MacWrite* to write my Ph.D. thesis in physics, and I believe that the advantages of using *MacWrite* far outweighed its disadvantages. I had some help from Prof. Gerald Heller at Brown University, who created a Greek letter font for me. Using the Greek letters and the math symbols available on the Macintosh, I was able to include complicated equations in the text.

Since *MacWrite* displays on the screen a close copy of what the Imagewriter prints, you can write equations involving fractions and integrals requiring

more than one line of text. These equations are particularly difficult to create with ordinary word processors, because the spacing on the screen often does not match the spacing of the printed output, and Greek symbols often do not appear on the screen.

The ten-page limitation of *MacWrite* did not present a problem, since I divided the thesis into sections of less than ten pages. I formatted an empty file called Set-up and opened it whenever I wanted to start a new section. With a second disk drive, the whole thesis (175 pages) easily fit on one disk. Certainly *MacWrite* can be improved, but it is already an excellent tool for demanding writing projects.

Jefferson Strait
Atlantic Heights, New Jersey

A Worm in the Apple

I have come down from the initial delight of becoming a Macintosh owner and am now stranded between tears at the large amount of money that I might have just wasted and euphoria at what the future might bring to the Mac. I am a college student and got the "special deal" on my Mac. It turns out, though, that the price I paid is about the same as the discounted prices now offered by many dealers. I bought a Mac

INTRODUCING
MouseAround™



... the *MouseAround* drawing tool
for the rest of us.

Sure MacPaint is a great program, but did you ever try to copy a drawing with the mouse? Like your company logo, clip art, a cartoon, a map or a sketch? Rather difficult unless you're an artist! Well not with the *MouseAround*... the drawing tool for those of us without natural artistic talent. Simply place the drawing to be copied on the *MouseAround* drawing board and insert your Macintosh mouse. Trace your drawing easily and faithfully using the red cross-hairs engraved in *MouseAround's* clear plastic frame. *MouseAround's* simple sliding mechanism retains perfect horizontal and vertical alignment of the mouse, thus assuring accurate copying of your drawing. *MouseAround* is also compatible with the Apple II series mouse and the MousePaint package. *MouseAround*... the Mouse drawing tool that makes the rest of us look like artists.

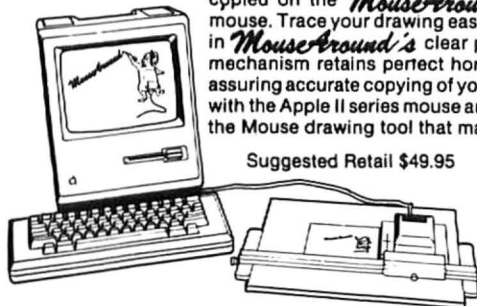

Suggested Retail \$49.95

Patent Pending

See us at the
Macworld Exposition
Booth #337

Moussessories™ ... products that make the best computer even better!

MouseMat™

MouseMat has two important functions. First, it provides a clean smooth rolling surface for your Macintosh mouse. The surface of most desktops is like a magnet for dust and invisible small particles of dirt and grit. Constantly rolling your mouse over this contaminated environment could damage its delicate inner workings. Your mouse will glide effortlessly and safely over the hard rubber surface of the *Mouse*



Mat. The *MouseMat* also allows for more accurate positioning of the mouse pointer. Second, the *MouseMat* safely drains away harmful static charges through its built-in grounding system. Because you touch the *MouseMat* every time you use your mouse, static buildup is continuously dissipated. Each 11½" x 13" *MouseMat* comes equipped with an 8 foot snap-on ground cord and a one megohm resistor. The backing on the *MouseMat* prevents slippage during use. The *MouseMat* is extremely durable and stain resistant. The *MouseMat* is also compatible with the Apple II series mouse, and the Apple Lisa mouse.

Suggested Retail \$29.95

MacCover™

MacCover is a custom tailored set of anti-static dust covers for your Apple Macintosh computer system. It will protect your Macintosh from dust, dirt, and spills.



MacCover is made from 6 gauge anti-static vinyl with machine stitched reinforced seams. The *MacCover* package includes four pieces, one cover each for your Macintosh, keyboard, mouse and Imagewriter printer. *MacCover* affords low cost protection for your valuable computer investment.

Suggested Retail \$29.95

Moussessories™ . . .

are available now through your local Apple Computer Dealer.



MouseMedic™



MouseMedic is a cleaning kit for your Macintosh mouse. *MouseMedic* contains all the supplies required to clean your mouse as recommended by Apple in your Macintosh Owner's Manual. Inside the mouse case are two rubber rollers. The oil that collects on these rollers is removed with foam-tipped swabs and a specially formulated solution that does not leave a residue. Hair and dirt particles entangled in the rollers are extracted with a precision pair of non-metallic tweezers. The mouse ball is cleaned with lint free towels lightly soaked with the cleaning solution and then dried with an anti-static cloth. The interior of the mouse case is wiped out with a small air brush. A can of compressed air with a long thin flexible nozzle is provided to blow out dust from inaccessible parts of the mouse. Proper care of your mouse will assure that it always operates and that it will continue to function for a long time. *MouseMedic* is not just for your mouse. The supplies in *MouseMedic* will also clean your complete Macintosh system, including the screen, keyboard and printer. *MouseMedic* is compatible with the Apple II series and the Apple Lisa.

Suggested Retail \$19.95

because I was immensely pleased with my Apple II + , but I find that I have been entirely excluded from the workings of the Mac. The documentation is pathetic coverage of the obvious. *Macworld* is the only useful documentation available for the Mac, but I resent having to wait a month for each tidbit of system information that should be in the manuals. It seems that Apple wants to make me pay heavily for my brand loyalty by giving me a machine that is capable but colossally useless.

Finding things out about the machine is virtually impossible because even the software developers don't know anything. Apple needs to write a user manual and give it away to all Mac owners who have supported them from the beginning instead of trying to rip us off with rampant overpricing and self-inflated hype. The Mac is great for computer illiterates, but it should also have been great for the programmers and hobbyists who had plans to use its capabilities.

Steven P. Redman
Seattle, Washington

Travels mit Mac

I have just taken my Mac and my Iie to Germany for a year of academic work. In response to Robert Buderer's article ["Travels in the Orient with the Mac," July/August 1984], I would like to inform your readers that taking these systems along and hooking them up to 220 volts and 50 cycles is probably easier than they think.

Carrying the Mac with its second drive and keyboard in the commercially available carrying case posed no problems. The carrying case does indeed

Address: 316 California Avenue, Suite #712 Reno, Nevada 89509 (702) 786-4600

Apple, MacPaint and MousePaint are trademarks of Apple Computer, Inc.

Macintosh is a trademark licensed to Apple Computer, Inc.

Moussessories, MouseAround, MouseMat, MouseMedic and MacCover are trademarks of Frontrunner Computer Industries.

Circle 178 on reader service card

fit under the seat in a Boeing 737 as well as under the seat in a Boeing 747—and I do not mean in first class but in “super economy”—that is, People Express from Portland, Maine, to London. I recommend that prospective Mac travelers sign up for an aisle seat, where the Mac will definitely fit. The Imagewriter and the IIfx, by the way, fit very nicely side by side in a large suitcase. The monitor should be in its original box and can also be handled as luggage by the airline.

As to getting the Mac ready to run on European power, a little planning makes all the difference. If you plan to run any other low power consumption articles like a printer, a modem, or another small computer, take a U.S. power strip along (six outlets with some kind of surge protector built in would be an excellent choice). Be prepared to “sacrifice” the plug on this power strip to be able to connect the power strip to a transformer.

Depending on where you plan to go, you should either get a transformer in the U.S. or depend on European sources. Almost all large European cities have electronics parts stores. Transformers are a very common item and are normally called “Autotransformers” or, in German, “Spartransformator.” A 75-watt transformer (sufficient for the Mac) costs about \$13.

Once you have bought the transformer, you should go to a shopping center and buy a grounded plug and a piece of wire to connect the transformer to the local power. Connect your U.S. power strip to the 110-volt connector and you are ready to run your Mac. Be

Rev-Pack Carrying Case



\$59

Why pay more for a Mac carrying case than you have to? Get all the features and utility of cases costing much more. Our Carrying Case is priced at just \$59 and includes a one year warranty.

These luxuriously finished cases are made by Rev-Pack, a leading manufacturer of soft, sturdy luggage. The outside covering is made of long-wearing and water-resistant Cordura.

Outside pockets hold disks and manuals. Thick, high-density foam makes the case shock resistant. Inside the case, there is a padded pocket, with separate mouse pouch, for accessories and cords.

Other features include: heavy-duty, no-rust zippers, dual reinforced carrying handles, and adjustable, padded bias-mounted shoulder strap. The case is available in black or gold.

Our price is the whole price. All prices include UPS surface charges and insurance. In a hurry? Two day UPS air service is just \$5. Circle 172 on reader service card

No Risk Guarantee

If you are not completely satisfied with your purchase, you may return it within 30 days for a full refund, including the cost to send it back. If you can get any of our competitors to give you the same guarantee, buy both and return the one you don't like.

Order Today, Shipped Tomorrow!

For fastest delivery, send cashiers check, money order, or order by credit card. Personal checks, allow 18 days to clear. California residents, add 6% sales tax. Hours: Mon.-Fri. 8:00 a.m.-6:00 p.m. PST Sat. 9:00 a.m.-1:00 p.m. PST

(800) 821-4479

Toll Free Outside California

(805) 987-9741

Inside California

QUBIE'



4809 Calle Alto
Camarillo, CA 93010

London (01) 223-4569
Paris (01) 321-5316
Sydney (02) 579-3322

© Qubie' 1984

We've been busy!

Our crew of Mac addicts run new programs as fast as they come in, and we've outlined a few of our favorites to give you a better idea of what there is for the Macintosh (so far), as well as what's coming.

DATABASES

OverVue

PROVUE

The database approved for use in-house at Apple. **OverVue** is written in assembly language, and it's fast (sorts 1000 records in 2 seconds)! Spreadsheet-like display for easy data entry, advanced math capabilities, and data exchange between Microsoft's Multiplan and Chart. Stores 8 report templates, and can handle up to 15 pp on 128K Mac. A sophisticated, powerful new package.

OverVue..... \$199.88

Filevision

TELOS

A unique database manager. **Filevision** is perfect for unusual data processing/database applications (like storing data associated with objects or events). Not the best choice for traditional DB applications like mail lists.

Filevision..... \$139.88

PFS:File/PFS Report

Software Publishing

Our choice for the best general-purpose database. **PFS:File** is form oriented, so you see reports formatted on-screen, as they'll print out. Contains the only key-word search feature for text that we've seen. **PFS:Report** adds math functions to the report generator. Calculate statistic functions, averages, and derive additional columns from existing file data. We suggest you get both **File** and **Report** for optimum performance.

PFS: File..... \$89.88

PFS: Report..... \$89.88

1st Base..... \$ 139.88

DB Master..... 139.88

Habadox DB..... 139.88

Habadox Adapter..... 39.88

Main Street Filer..... \$139.88

MegaFiler..... 139.88

Odesta Helix..... 279.88

Omnis 2 (new version w/mouse support)..... 199.88

GAMES

Sargon III

HAYDEN

It's here at last, and worth the wait. **Sargon III** teaches you to play better chess as well as providing a worthy opponent. Practice openings, tactics, strategy, closings and checkmating. You can also replay 107 famous games with the masters. More than a game...

Sargon III..... \$39.88

Mouse Stampede

MARK OF THE UNICORN

Like Millipede, but with rampaging mice. Fast action and lots of fun, but take it easy on the Mouse in your hand.

Mouse Stampede..... 29.88

Millionaire

BLUECHIP

Real men don't play games—they run simulations! A challenging stock market simulation where you buy/sell in response to market info and news events. Much too good to waste on kids.

Millionaire..... 44.88

Baron..... \$ 44.88

Frogger..... 29.88

Forbidden Quest..... 34.88

InfoCom Games..... CALL

MacManager	\$ 39.88
MacSlots	54.88
Murder by the Dozen	34.88
Pensate	29.88
Run for the Money	39.88
Transylvania	29.88
Trivia	39.88
Tycoon	44.88
Videx FunPak	29.88

FINANCIAL/BUSINESS

Sales Edge

HUMAN EDGE

Answer questions about your sales prospects and yourself, then let **Sales Edge** run its report. Its uncannily accurate rundown describes prospects and how you should handle them, including closing techniques, pitfalls, etc. If you can be objective, **Sales Edge** can really help.

Sales Edge..... \$179.88

Dollars & Sense..... \$ 114.88

Home Accountant..... 79.88

Management Edge..... 179.88

Multiplan..... 139.88

TKI Solver..... 179.88

TKI Templates..... CALL

LANGUAGES

MacForth

CREATIVE SOLUTIONS

We think **MacForth Level II** is the best-buy in any language so far. Full tool-box support, including menus, windows, I/O management. Includes assembler/debugger, floating-point math and extended utilities. A great buy.

MacForth (Level II)..... \$179.88

Microsoft

BASIC 1.02..... \$ 109.88

BASIC 2.0..... CALL

MacForth (Level I)..... 104.88

Softworks "C"..... CALL

WORD PROCESSING

Mac Daisywheel Connection

ASSIMILATION PROCESS

Letter-quality printing is here! **Mac Daisywheel Connection** is transparent to any application using the Imagewriter file. Installs easily on system and supports Apple, Brother/Dynax, NEC and Qume letter-quality printers. Boldface/underlining is supported on printers that offer it. Package includes printer cable.

Mac Daisywheel Connection..... \$79.88

Mac Spell Right..... \$ CALL

MasterType..... 39.88

MegaMerge..... 89.88

PaintIt MacType..... 39.88

Think Tank..... 99.88

Typing Tutor III..... 39.88

GRAPHICS

Art Portfolio

AXALON

120 pictures with a detailed manual and "how-to" tips for using artwork. Worth the money for the manual alone.

Art Port...... 44.88

Hayden

Davinci Buildings..... 39.88

Davinci Interiors..... 39.88

Davinci Landscape..... 39.88

McPicl..... 39.88

McPicl Vol 2..... 39.88

Mac the Knife..... 29.88

Microsoft Chart..... 89.88

T/Maker Click Art

T/M Personal..... \$ 39.88

T/M Publications..... 39.88

OTHER

Dow Jones Straight Talk..... \$ 59.88

Videx MacCalendar..... 64.88

HARDWARE

Microline 92

OKIDATA

Full Imagewriter compatibility, and much better quality in hi-res and draft modes. It's a bit slower than the Imagewriter, but the final output's worth it. **Microline 92's** are rugged, with 160 cps (Shannon Text), 10, 12 and 17 cpi, a correspondence font and full graphics support for the Mac. Cable included.

Microline 92 w/cable..... \$499.88

3½" Diskettes

(5 pkg)..... \$ 24.88

(10 pkg)..... 43.88

Printer & modem cables..... 29.88

FieldPro Carrying Case..... 79.88

Diskette Holder..... 24.88

Kensington Starter Pak:

Includes Swivel Stand, Surge Protector and anti-static Dust Cover..... 69.88

Kensington Modem..... \$ 119.88

Surge Suppressor..... 44.88

Microcom MacModem..... 499.88

MacPhone..... 149.88

Micron-Eye

(digitizer camera)..... CALL

Novation SmartCat+

Modem/Software..... 349.88

Tecmar MacDrive

5MB Cart..... CALL

10MB Fixed..... CALL

10MB Fixed/5MB Cart..... CALL

Hey, MAC!

Our newsletter, **Hey, MAC!**, has become the most popular Macintosh product we carry. **Hey, MAC!** reviews and examines the ever-changing and always exciting Macintosh marketplace; we offer tips on using your Mac, product reviews and a software/hardware availability list. Originally published to give our customers updated information on new products and their availability, **Hey, MAC!** is now available to everyone. You can order 5 issues of **Hey, MAC!** for only \$10, and your subscription starts with the current issue. (Sorry, no back issues are available).

Hey, MAC!..... \$10.00

TECHNICAL SALES DESK

(603) 881-9855

TOLL-FREE ORDER DESK

(800) 343-0726

Hours: 9:00 to 5:30 EST, Mon-Fri

■ FREE UPS ground shipping on all orders over \$50 (under \$50 add \$2.50 shipping & handling)

■ MasterCard, VISA, American Express, Diners Club & Carte Blanche credit cards accepted

■ No surcharges on credit cards

■ Credit cards are not charged until your order is shipped

■ All personal checks held 30 days for clearance

■ CODs accepted up to \$1000 (add \$10 for COD handling). Payable with certified check, money order or cash.

■ Software can be returned for an exact exchange only; no credits or refunds issued

■ Sorry, no APO/FPO or foreign orders

■ Allow 10 days for delivery

BOLDFACE ITEMS are currently shipping as of 10-22-84. Call for availability on new products or those listed in this ad.

careful with the 220-volt connection, and ground everything correctly. Make sure that there are no exposed wires—touching 220 is an experience you won't have time to tell about. It is lethal. For those who do not dare to make these connections: a local electrician can set you up for a very small fee, if you bring in the parts.

For Mac users who do not mind a little heat coming out of the 75-watt transformer: yes, the Imagewriter printer runs fine together with the Mac on the same transformer. I recommend that the Imagewriter be turned on only when printing needs to be performed.

Modem users should be prepared to use acoustic modems only. In West Germany, for example, it is strictly illegal to connect directly to the phone system. Nevertheless, most phone parts are available. Fines have been issued and collected by the German federal communications officials. Modem users who do not mind the risk of a fine should bring along a cable for connecting their modem to the standard European connectors. Once again, they will have to sacrifice one plug to convert one side of the cable to the non-U.S. outlet. European data transfer protocols are different from those used in the U.S. You won't be able to hook up to the local bulletin board in Europe.

Needless to say, the ability of the Mac to produce print in all European languages is a tremendous asset over here. Its graphics capabilities are superb. The price, on the other hand, is simply shocking! Two Macs cost about the same as a well-equipped small car.

Otmar K.E. Foelsche
Bremen, West Germany

HIGH TECHNOLOGY AT AFFORDABLE PRICES

THE BOTTOM LINE

MILFORD, NH 03055-0423 • TECHNICAL (603) 881-9855 • ORDER DESK (800) 343-0726

Circle 33 on reader service card

Please Don't Tease

Recently, I went to the local watering hole after work to have a few beers with some of my fellow knowledge workers. A commercial for the Macintosh appeared on the tube and I pricked up my ears, as I'm a Mac owner. The commercial showed a lone Macintosh, introduced it as Apple's new computer, and then zoomed out to show a multitude of Macs, all displaying some sort of fuzzy and nebulous software on their screens. The announcer informed us that this was some of the software being developed for the Macintosh "at the rate of one program per business day."

"That's great!" I thought. "One can't run a small business efficiently with only *Habadex*, *MegaMerge*, and *Transylvania*. I'll save up some money, visit my computer store 30 business days from now, and browse through the 30 new programs they'll have." Imagine my surprise when I went to a computer store over a month later and found that they'd added only 9 programs to their supply. I think Apple is adding insult to injury by tantalizing the software-starved public with this commercial.

Phil Studge
San Francisco, California

Letters should be mailed to Letters, Macworld, 555 De Haro St., San Francisco, CA 94107, or sent electronically to CompuServe 74055,412 or The Source STE908. □

INTRODUCING

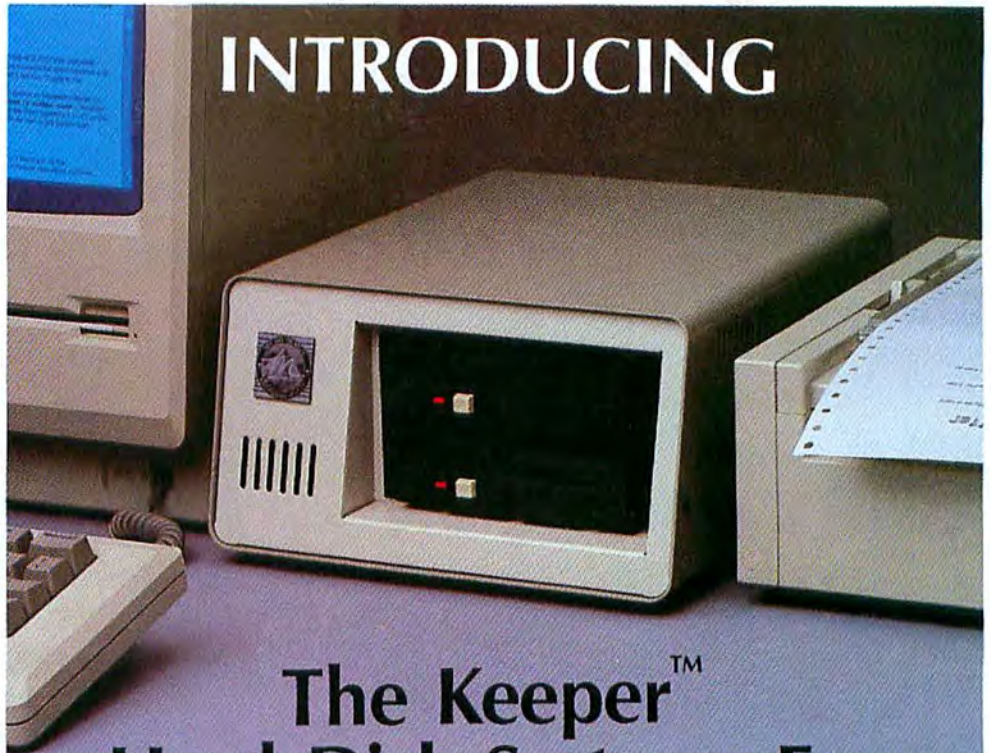

The Keeper™ Hard Disk Systems For Macintosh™

Speed up your Mac by 400-600%,
Add up to 33 Mbytes of storage,
AND, Keep your Mac working for you while you
print! (Micro-Design built in a printer buffer!)

Features:

- Runs 4 to 6 times faster than floppy drives
- **Built-in Printer Buffer**
- Password protected volumes
- Available in 6 configurations, including combinations of fixed and removable hard disks
- Works with AppleTalk Personal Network
- No hardware modifications needed
- Leaves you access to all peripheral ports

For Original, Upgraded, and New 512K Macs!

Call 1-800-531-5002.
In Texas call 512-441-7890.
We welcome dealer inquiries.



Micro-Design

6301 Manchaca
Austin, TX 78745

Apple is a registered trademark and Macintosh is a trademark licensed to Apple Computer, Inc. The Keeper is a trademark of Micro-Design.

ODESTA HELIX

An Interactive Information System
For Individuals With A Need To Know

With Odesta Helix, you can model worlds of ideas, things, and relationships, and watch them live and interact upon your desktop. Odesta Helix is a new program – not an old program made to work on a new machine. It takes a new approach – letting you define and control the shape and form of information according to your own needs and style. Odesta Helix gives you a rich and powerful set of visual tools that lets you begin working immediately, without having to learn a programming language or battle with the restrictions of "spreadsheet" type thinking.

Relation icon
to set up different
"data bases"

Field icon represents
types of information

Template icon for
constructing and
changing forms

Index icon lets you get
at things in whatever
order you want

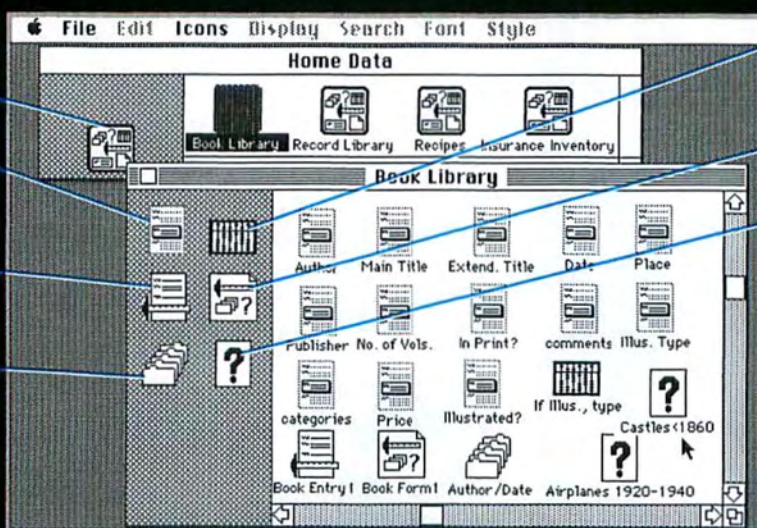

Abacus icon for
setting up calculations
and relationships

Form-view icon pulls
everything together

Query icon lets
you do interactive
searches

Odesta Helix uses icons (visual symbols) to represent ideas, relationships and functions as objects that you can easily manipulate. Create them by clicking on the icon-wells on the left, and dragging them to your desktop. Each opens to reveal deeper and deeper operations and values that may be invoked and shaped with the click of a mouse button.

Odesta Helix™ & Macintosh™

The Next Step.

Tiles act as arithmetic, text, Boolean and date operators, functions and values.

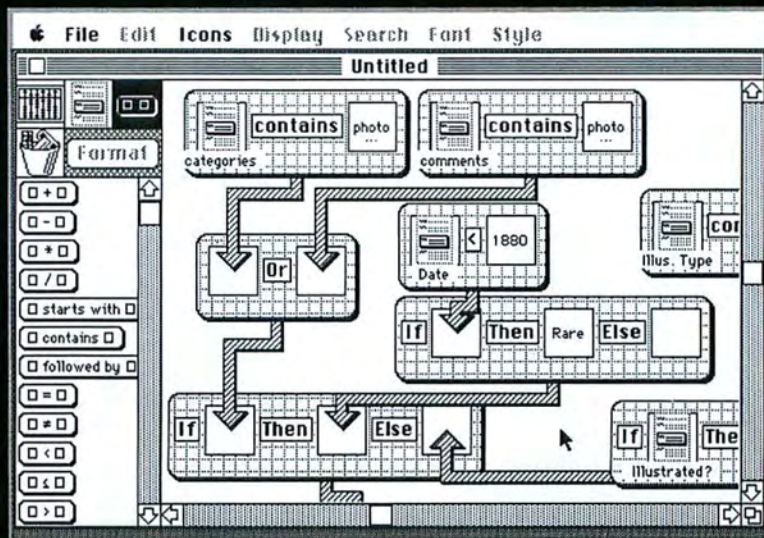

Visual building blocks let you set up even the most complicated statement or calculation and use it whenever you want to. Drag tiles out from the list at the left. Drop icons into the tile holes, or type in numbers or text. Connect the tiles by pulling arrows around. This whole calculation is represented by a single abacus icon that may be used on any form, and you may make up as many as you feel like.

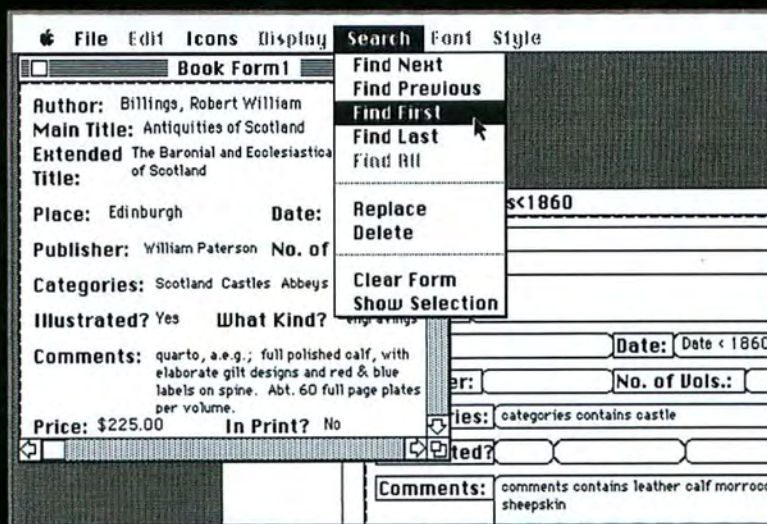

Here is a form-view being used in conjunction with an interactive search form (query icon titled "Castles - 1860"). One aspect of the radically innovative design of Odesta Helix is that you can enter, query, edit, and print information all from one window - without having to shift from one mode or application to another. Another reflection of this dynamic design is that if you make a change in one window, you see the result pop-up in any open related window.

For Macintosh Users in the Driver's Seat...

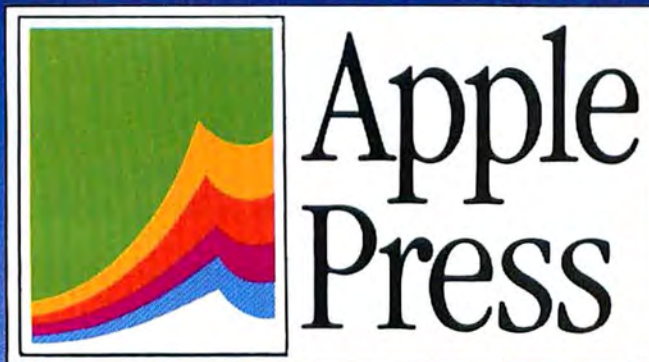

This is the sign to look for

"Apple believes that good books are important to successful computing. The Apple Press imprint is your assurance that this book has been published with the support and encouragement of Apple Computer, Inc., and is the type of book we would be proud to publish ourselves!"

When it comes to programming the Macintosh and you're looking for authoritative resources, this endorsement and logo indicate that the books on which they appear are highest quality publications. When you pick an Apple Press Book in the Macintosh Programmers' Series, you've picked the best!

At present, Apple Computer, Inc. has selected five titles from Hayden's Macintosh Library for the Apple Press endorsement. *Now available:*

INTRODUCTION TO MACINTOSH BASIC by Scot

Kamins. This book, with step-by-step guidelines, illustrates how to use various built-in programming tools of Macintosh Basic, unique commands and programming instructions, the powerful Macintosh Editor, and special accessories for developing, testing and debugging programs. \$18.95

Ready soon

**WORKING WITH MACINTOSH BASIC
MASTERING MACINTOSH BASIC
MACINTOSH REVEALED
MACINTOSH PASCAL**

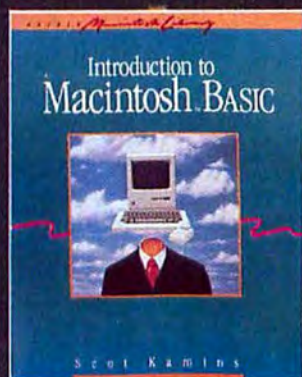

HAYDEN BOOK COMPANY 10 Mulholland Drive, Hasbrouck Heights, New Jersey 07604

In Canada: Holt, Rinehart & Winston, 55 Horner Avenue, Toronto, Ontario M8Z 4X6

Macintosh is a trademark of Macintosh Laboratory, Inc., licensed to Apple Computer, Inc.

Circle 9 on reader service card

*** ALERT ***
ASK FOR NEW CHALLENGES
FROM PRIORITY SOFTWARE
AT YOUR DEALER
THIS MONTH!

YOU'VE PROCESSED YOUR WORDS, SPREAD
YOUR SHEETS, AND TESTED YOUR HAND-EYE
COORDINATION WITH ARCADE GAMES...

IT'S TIME

... to challenge your mind's eye
... to put some adventure in your life
with an Artext adventure from Priority Software.

Escape into the worlds of **FORBIDDEN QUEST**, an interactive science fiction adventure. Stimulating prose and five vivid graphic art prints combine to transform the adventure into REALITY. Lose yourself on a journey that will have you facing danger and challenges where your ability to think clearly and logically are your only defenses against failure and reward—death. You must succeed in your mission if the galaxy, as you know it, is to survive. You must travel through over 100 locations, mastering two starships and surviving three hostile planets in order to complete the quest—OR DIE.

YOU MAY NEVER PLAY AN ARCADE GAME AGAIN

"Forbidden Quest's plot is intriguing and has some of the appeal of an Andre Norton novel. This is a superior program."

Michael A. Banks, Softalk (Apple)

"The opening scene is as vivid as any opener I've played."

Scott Mace, Infoworld

"If you're a video-game enthusiast and have never played a text adventure before, you might want to give your reflexes a rest and look at this one."

Dian Crayne, Softalk (IBM)

"This is undoubtedly the most significant piece of software ever produced, or that will ever be produced, in the universe as we know it... honest!"

*Pierre d'Avenas
Director of Marketing
Priority Software*

PICK ONE UP AT YOUR LOCAL DEALER OR CALL
(408) 757-0125 FOR ORDER INFORMATION

ALSO AVAILABLE FOR
APPLE][+,][e.][c. IBM-PC & PC JR. FOR \$39.95
MACINTOSH VERSION \$44.95

**Priority
Software**
INCORPORATED

Adventures for the Mind

APPLE and IBM are registered trademarks of Apple Computer, Inc. and International Business Machines, respectively. **Forbidden Quest** and **ARTEXT** are trademarks of Priority Software, Inc. ©1983 Priority Software, Inc. All Rights Reserved.

P.O. Box 221959, Carmel, California 93922

FORBIDDEN QUEST

AVAILABLE FOR MACINTOSH NOW

- ON-LINE INSTRUCTIONS & MULTI-LEVEL HINTS
- EXTENSIVE USE OF MACINTOSH CAPABILITIES

Custom icons & cursors, scroll back through 5K of responses, extensive utilization of mouse and pull down menus, a "panic" button to protect the guilty.

DISTRIBUTED BY FIRST SOFTWARE, SOFTSEL, MICRO D, COMPUTERLAND CORP. AND OTHER FINE DISTRIBUTORS

Circle 127 on reader service card



Feed your Mac.

Introducing ThunderScan.™

Now you can turn any printed image into a detailed, high-resolution Macintosh graphic.



Just roll your original into your Imagewriter.



ThunderScan scans and digitizes the image.



Presto! A high-resolution MacPaint document.

No doubt about it, Macintosh is one great graphics machine. But until now, Mac graphics have been limited to what you can draw with a mouse and what someone else has put on a disk. Consequently, taking full advantage of Mac's graphics capabilities has been tough. But now there's ThunderScan. The new optical scanning device that lets you feed your Mac a steady diet of graphics that are useful to you.

ThunderScan turns Mac's Imagewriter printer into an image reader. So you can digitize any printed image and turn it into a detailed, high-resolution MacPaint document. Anything, including forms, half-tones, photos, mechanical drawings, maps, floorplans, logos, signatures and more. From black and white and color originals. ThunderScan reproduces them at over 200 dots per inch and in 32 shades of gray.

ThunderScan's application software, written by Mac-team-member, Andy Hertzfeld, makes it an extremely versatile and useful tool. You can gen-

erate full-page images or selected parts of them. Enlarge and reduce them. Manipulate them. Control the contrast and brightness. Create your own personal image disk. "Cut" and "paste" images together, creating new documents. And print them out on your Imagewriter. Or send them by modem to another Mac. The possibilities are nearly endless.

No lights, no camera, just action.

What you see here is the complete ThunderScan system. You don't have to buy an expensive video camera. Just pop out your Imagewriter's ribbon cartridge, snap in ThunderScan and you're set.

It can even work in the dark (maybe you can think of an application for that).

If you bought a Mac at least partly for its graphics, only to find you couldn't take full advantage of them, now you can. With ThunderScan.

At an introductory price of just \$229, it's a small price to pay for a whole new graphics capability.

For more information or a ThunderScan of your own, see your dealer or call us today.

(415) 254-6581



ThunderScan

Thunderware Inc., 19 G Orinda Way, Orinda, CA 94563

Introducing Accounting For Those With A Mouse In The House. (Or Office)

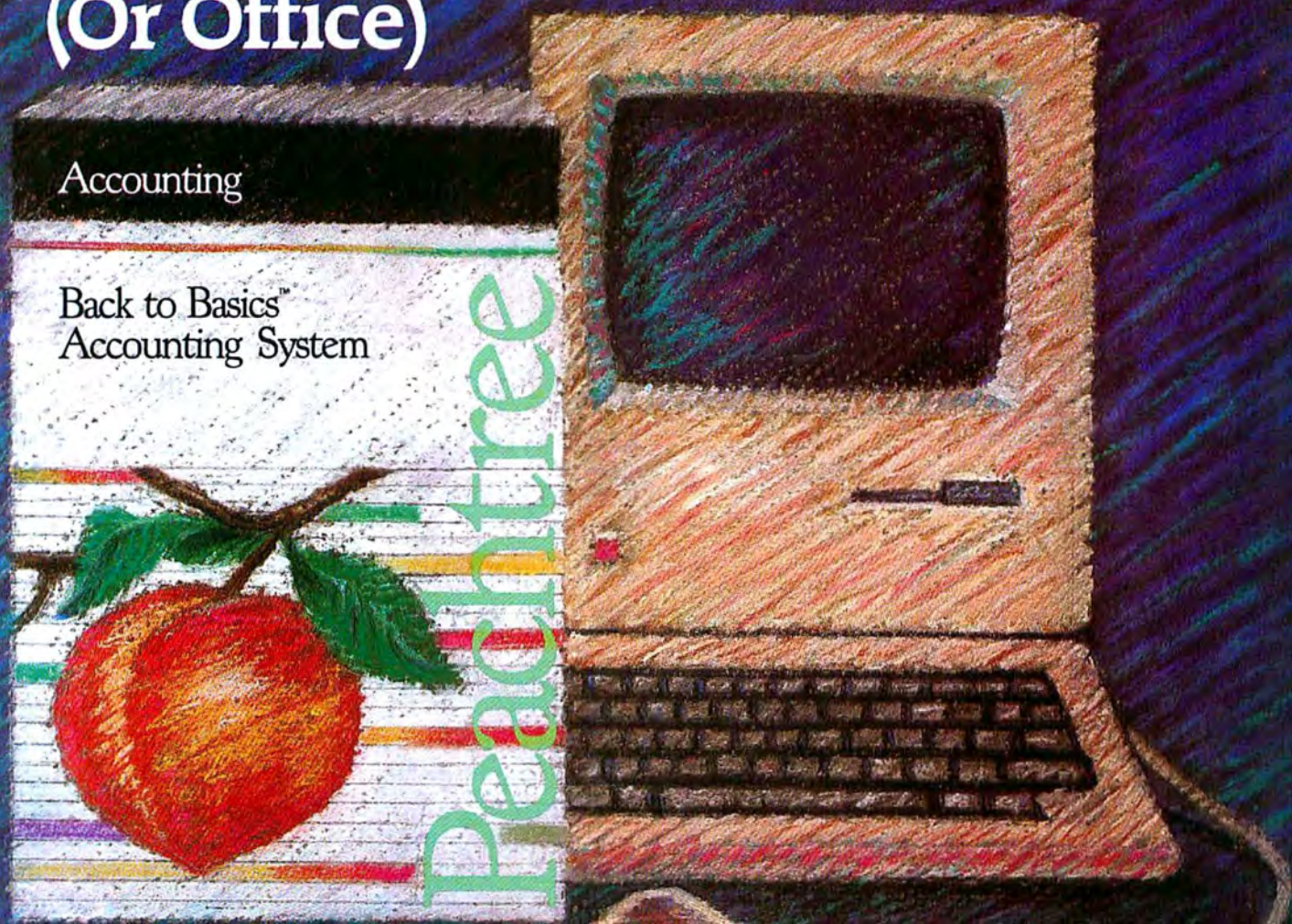

Back to Basics Accounting System by Peachtree Software® is now available for the Macintosh.™ It's named Back to Basics because it is an uncomplicated, easy-to-learn accounting system for small businesses.

You don't need any accounting experience and barely need any computing experience. The straightforward manual teaches both accounting and computing at the same time.

But make no mistake. This is a full-featured series of interactive products including General Ledger, Accounts Payable and Accounts Receivable.

The first business accounting system for the Macintosh, Back to Basics has been enjoyed by owners of Apple® II+,

Ile and Iic all along. In fact, you've probably seen it featured in Apple Macintosh advertisements.

Uncomplicated—easy-to-learn—yet full featured. That's Back to Basics.

For more information, contact your local dealer or Peachtree Software, 1-800-554-8900.

America's Software grows on the Peachtree.®

Peachtree Software

Apple is a registered trademark licensed to Apple Computer, Inc. Macintosh is a trademark licensed to Apple Computer, Inc. Peachtree and Peachtree Software are registered trademarks of Peachtree Software Incorporated, an MSA Company.





Introducing MACWORLD

The Macintosh Magazine

**The Exciting New Magazine for
the World's Most Creative Personal
Computer—the *Macintosh***

**At Special Charter Subscriber Rates
Save Up to 63% Off the Newsstand Price**

(when you subscribe for 2 years)

Personal computing took a giant leap into the future when Apple introduced the Macintosh. We've created *Macworld* as your passport into this incredible new realm of computing. Each issue brings you everything you need to explore and get the most out of your Macintosh. From the latest product news to innovative business applications, from amazing graphics to personal productivity tools and games, each issue of *Macworld* is packed with interesting, practical, readable information written by skilled, perceptive writers.

Each month we'll be creating a *Macworld* community; sharing ideas, problems, and creative solutions while we explore the world of Macintosh together.

So why take a chance on missing a single exciting issue? For a limited time only you can subscribe to *Macworld* at special Charter Subscriber rates of only

▲ **\$19.97 for 1 year (13 issues)**

That's a savings of 33% off the regular \$30 subscription rate and 61% off the newsstand price!

**And you can save even more by subscribing
for 2 years at Special Charter Rates.
Don't Wait... Subscribe Today and Save!**



Special Charter Subscription Offer

Save 61% off
the Newsstand Price!

~~\$5.95~~

Newsstand

~~\$30~~

Regular Subscription Rate

\$19.97

Special Charter
Offer

Order Now to Take
Advantage of This
Limited Time Offer!
VISA and MasterCard
Accepted! Call TOLL FREE:
800-247-5470
(in Iowa 800-532-1272)

I ACCEPT! Please send me *Macworld*, the Macintosh magazine. Please send me 12 monthly issues PLUS the special Software Review issue, all for just. \$19.97. I'll save 33% off the regular subscription rate.

- \$19.97 for 1 year (12 monthly issues PLUS the special Software Review issue)
SAVE EVEN MORE!
 \$37.97 for 2 years (26 issues)

Name

Company

Address

City, State, Zip

Please allow 6 to 8 weeks for delivery of your first issue. All orders must be prepaid in U.S. funds. Outside the U.S. and Canada rates are \$32.97 per year for surface mail or \$84.97 per year for airmail.

Offer expires September 30, 1985.

JM6A18

I ACCEPT! Please send me *Macworld*, the Macintosh magazine. Please send me 12 monthly issues PLUS the special Software Review issue, all for just. \$19.97. I'll save 33% off the regular subscription rate.

- \$19.97 for 1 year (12 monthly issues PLUS the special Software Review issue)
SAVE EVEN MORE!
 \$37.97 for 2 years (26 issues)

Name

Company

Address

City, State, Zip

Please allow 6 to 8 weeks for delivery of your first issue. All orders must be prepaid in U.S. funds. Outside the U.S. and Canada rates are \$32.97 per year for surface mail or \$84.97 per year for airmail.

Offer expires September 30, 1985.

JM6A18

I ACCEPT! Please send me *Macworld*, the Macintosh magazine. Please send me 12 monthly issues PLUS the special Software Review issue, all for just. \$19.97. I'll save 33% off the regular subscription rate.

- \$19.97 for 1 year (12 monthly issues PLUS the special Software Review issue)
SAVE EVEN MORE!
 \$37.97 for 2 years (26 issues)

Name

Company

Address

City, State, Zip

Please allow 6 to 8 weeks for delivery of your first issue. All orders must be prepaid in U.S. funds. Outside the U.S. and Canada rates are \$32.97 per year for surface mail or \$84.97 per year for airmail.

Offer expires September 30, 1985.

JM6A18

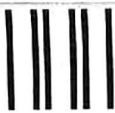

NO POSTAGE
NECESSARY
IF MAILED IN
UNITED STATES



BUSINESS REPLY CARD
FIRST CLASS PERMIT NO. 79 BERGENFIELD, NJ

POSTAGE WILL BE PAID BY ADDRESSEE

Macworld
Subscription Department
P.O. Box 20300
Bergenfield, New Jersey 07621



NO POSTAGE
NECESSARY
IF MAILED IN
UNITED STATES



BUSINESS REPLY CARD
FIRST CLASS PERMIT NO. 79 BERGENFIELD, NJ

POSTAGE WILL BE PAID BY ADDRESSEE

Macworld
Subscription Department
P.O. Box 20300
Bergenfield, New Jersey 07621

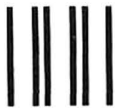

NO POSTAGE
NECESSARY
IF MAILED IN
UNITED STATES



BUSINESS REPLY CARD
FIRST CLASS PERMIT NO. 79 BERGENFIELD, NJ

POSTAGE WILL BE PAID BY ADDRESSEE

Macworld
Subscription Department
P.O. Box 20300
Bergenfield, New Jersey 07621

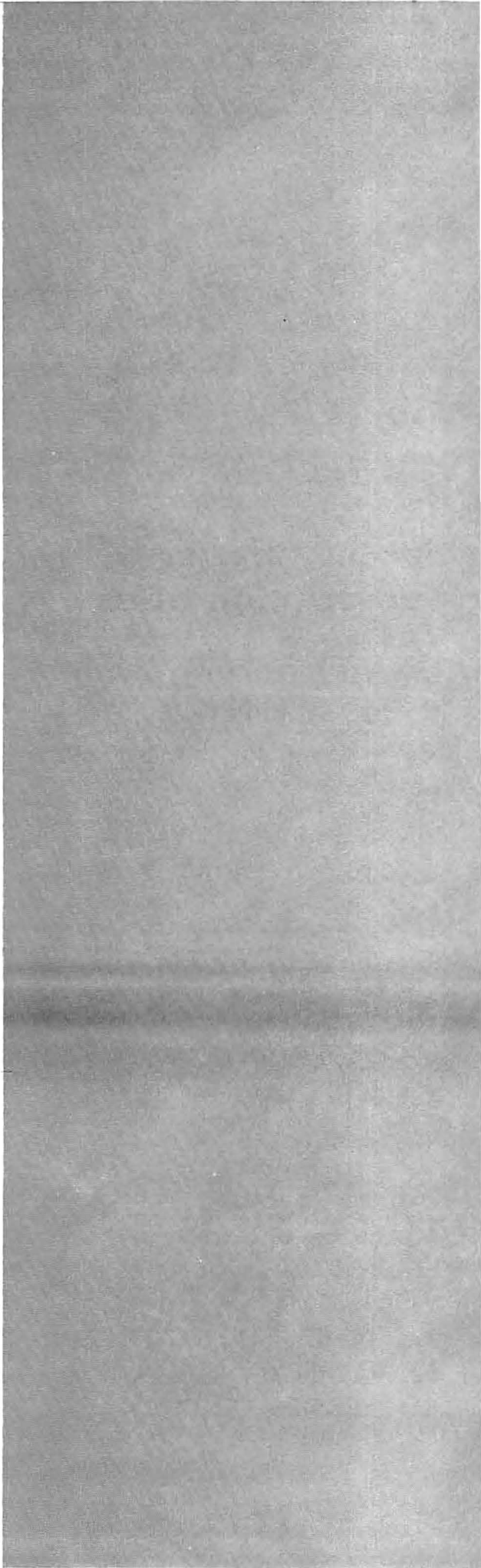

With Macalendar,TM You Would've Been on Time.



We know how easy it is to become so totally immersed in your work that you forget all about such things as 10 o'clock appointments, luncheon dates, or even (shudder) Board Meetings. That's why we designed Macalendar to help you plan, organize and implement your busy schedule.

Macalendar is a powerful time management tool for the MacintoshSM which uniquely combines a calendar with an alarm and a notepad – all designed to keep you on schedule and up-to-date. Best of all, Macalendar runs concurrently with all other programs, so it's *always there when you need it*.

Once you've entered important times and dates into Macalendar, you can go on to work on other applications. Macalendar will automatically interrupt your program with a chime to remind you of your appointment. There's no separate disk to insert; Macalendar is an ever-present, integral part of your Macintosh.

For detailed reminders or notes, take advantage of Macalendar's notepad. Simply enter memoranda for the appropriate day, and the information will be waiting for you when you call it up. Plan weeks – even years! – ahead. And never again miss another appointment, birthday, class, whatever.

Run out of room on your notepad? Just "turn the page" and fill unlimited pages with all your information. Macalendar lets you document phone

calls, assemble "to-do" lists, plan out a daily schedule, etc.

Now, finally, losing yourself in your work doesn't have to mean losing track of time . . . thanks to Macalendar.*

Macalendar, \$89; Lisa Desktop Calendar, \$295



1105 NE Circle Blvd. • Corvallis, OR 97330
(503) 758-0521

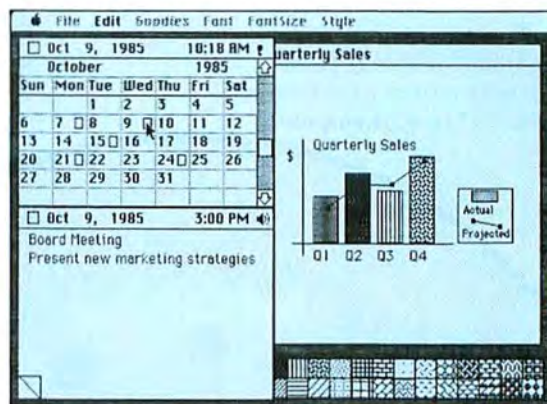

*Expanded version of Macalendar, the Desktop Calendar,SM is available for the Lisa. Macintosh is a trademark of Apple Computer, Inc. Lisa is a registered trademark of Apple Computer, Inc.

Circle 42 on reader service card

Macworld View

News and notes for the Macintosh community

Edited by Janet McCandless

Macworld View reports on new products and developments in Macintosh technology. We will cover items of interest to Mac users and comment on industry trends. We welcome contributions from readers and pay up to \$50 for each item we use. Please include your name, address, and phone number with your contributions; send them to Macworld View, 555 De Haro St., San Francisco, CA 94107.

Computerized Consultants

How many times have you tried to solve a problem with the data base program, spreadsheet, or other software that you purchased but couldn't figure out how to apply it to the job at hand? Often when people try to get help with the program they buy, their dealer refers them to the manufacturer, who refers them back to the dealer. But now they may actually be able to get solutions from the source of the problems—their computers.

A 24-hour computerized support service is now available from The Networkers, a business that specializes in solving Macintosh software problems for people who are trying to put their computers to work. The Networkers are a group of consultants who answer questions about application software over an on-line conferencing system. After you set up an account by phone, you are given log-on instructions that enable you to access the conferencing system with your Mac by modem.

The system offers two services: MacNet and MacNews. Through MacNet you contact consultants, who then answer your questions during conferences either on line or by electronic mail. When you log on to MacNet, you can get solutions for your computing problems by filling out an on-line questionnaire. The question is then referred to a consultant, who researches the problem and offers a solution. MacNews is an on-line newsletter that includes advice from members of the Mac and Lisa development teams.

Both the MacNet and MacNews services are included in the \$25 membership fee. Connect time costs \$98 an hour. You can minimize the time you spend on the system by immediately transferring answers to disk and reading them after you log off. Contact The Networkers, 3500 Market St. #103, San Francisco, CA 94131, 415/550-0929.—Adrian Mello

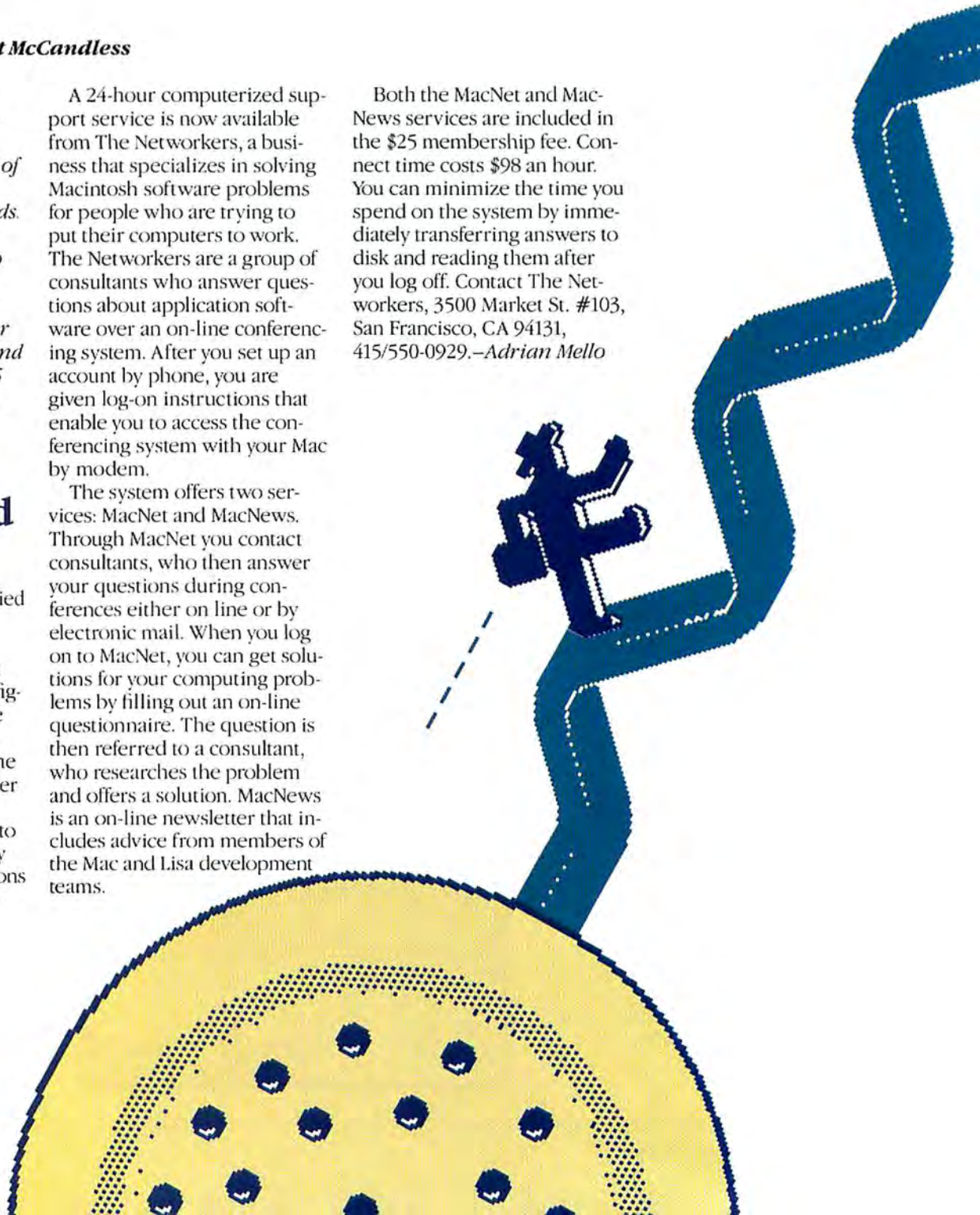

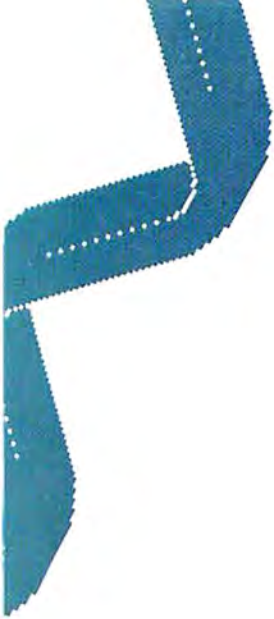

□□□□□□□□□□

Norris Palmer (left) and Josh Wilson in one of the homes they designed for computer commuters, people who work out of their homes and send in work to the office electronically.

A Mac in Every Home

It's doubtful that any politician ever had the vision to promise a "teleport" in every home and a Mac in every kitchen, but a new housing development in California makes just such a promise. Forty-five miles north-east of Sacramento, 360 homes are being built on 1338 acres in the Sierra Nevada foothills. Each house comes with a Mac and a room called the teleport, which is designed for telecommuters, people who regularly work out of their own homes and send computerized information to an office instead of physically traveling to the office.

The project designers have tried to anticipate the electronic communications requirements of twenty-first century homeowners. Every home has between eight and ten communications ports, with each one providing voice, data, and video hookup. A central switching network provides phone, data, and video communications to individual homeowners. Within



the village, owners will be networked for electronic mail between homes. The homes are built to order and range from \$160,000 to \$240,000. For more information, contact Norris Palmer or Josh Wilson, Eagle Crest, P.O. Box 1-D, Foresthill, CA 95631, 916/367-2801.
—Adrian Mello

Macworld Canvas

If you thought you had previously seen the matte-coated paper in *Macworld* used only in books, you are right. *Macworld* diverged from the consumer magazine publishing custom of printing strictly on glossy paper. In late 1983 Jacqueline Poitier, Vice President for Design of *Macworld* and *PC*

World, contacted S. D. Warren Co., a division of Scott Paper Company, about a paper stock called Somerset Matte, customarily used by book publishers.

Poitier believes that although paper quality is often ignored by readers, it is one of the most important elements in the mag-

azine. For her, paper is the starting point, the canvas of *Macworld*. But she faced the problem of finding paper for a new publication at the onset of a severe paper shortage that was predicted to continue into 1987. She wanted to find paper that would satisfy the readers' preference for stock with less glare than glossy paper, the advertisers' need for high-quality four-color ads, and her own requirement for premium stock.

S. D. Warren had a reputation for manufacturing high-quality paper. The company developed a formula that applies a finish to the paper so that the ink sits on the matte surface and is not absorbed. The softer matte finish accommodates the readers' preference for less glare, and the surface characteristics of the paper let colors retain their brilliance. Even though *Macworld* was to be the first magazine account that S. D. Warren supplied with Somerset Matte, the company's representatives assured Poitier that they could meet her paper needs.

Although *Macworld* will have paper during the coming years of paper shortage, relief for other publications is not assured. New paper mills can cost as much as \$250 million and take 18 months to build. The next one will not be producing paper until 1987. In the meantime, many publishers are going overseas to obtain paper stock, and other publishers are using alternate stocks to stretch their paper supply.

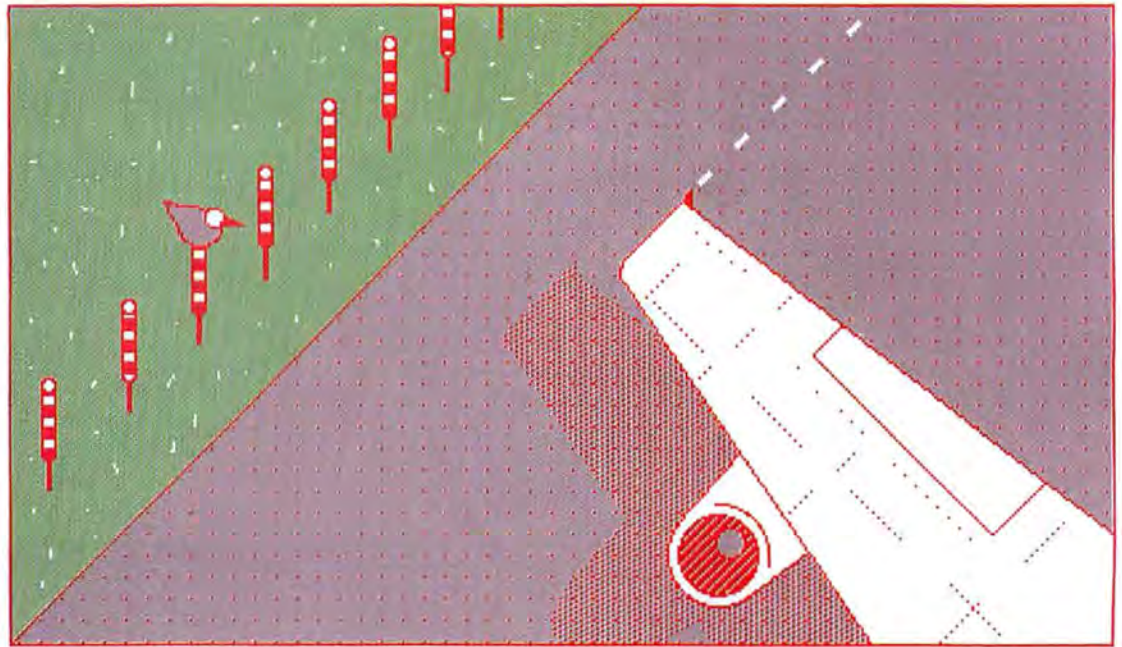

Macs in the Hangar

One government agency, the Arizona Department of Transportation and Aeronautics, has come up with an imaginative and practical Macintosh data base application. Department division director Sonny Najera is using Telos Software Products' *Filevision* to store information for a statewide data base on airport facilities. Najera is sending employees to approximately 60 Arizona airports to gather statistical data that will be tied to a map of each airport. Runways, taxiways, parking aprons, access roads, terminal buildings, aircraft hangars, fueling farms, and maintenance operations will be documented. He intends to document the number of aircraft, use patterns, flight frequency, and the kind of fuel the airport sells.

Department of Transportation employees will take Macs to airports throughout the state and enter information into *Filevision* on the spot.

The information will be used to help distribute grants to the airports and to anticipate the fiscal impact of each airport facility on the local community. To assist the department in this financial evaluation, Najera is also looking at other data bases, such as *pfs:file* and *pfs:report*, to track both revenues and costs of operation. The data base information will be used to evaluate the economic viability of an airport and the return on investment that can be expected from the facility. Until now, this level of data gathering and projection has not been performed for medium- and lower-level facilities. The airports operate as public facilities and are not considered sources of revenue. The data from these small- and medium-size facilities can be used to help make the airports self-sustaining and give pilots and local communities a realistic appraisal of costs.

Najera expects that the next *Filevision* application for the Department of Transportation and Aeronautics will be data bases for major streets and highways. If the data for all the roadways is tied to a data base, the department will be able to zero in on a section of a road-map to determine the condition of the pavement, and project maintenance costs and schedules for several years into the future.

Computers for the Rest of U.C.

The University of California, Berkeley, has an innovative approach to computer education using Macintosh computers. The course, prosaically entitled "Introduction to Computing," originates in the Interdisciplinary Studies Group of the College of Engineering. Its only prerequisite is that students not have prior computer training or

experience other than minimal use of a word processor. The course is designed for undergraduate humanities and social science students. The lecturers, Professor Richard White, an electrical engineer, and Professor David Patterson, a computer scientist, are from the Department of Electrical Engineering and Computer Science and are both known for their hardware achievements. The course developers have also consulted with the campus's Instructional Technology Office and SESAME (Search for Excellence in Science and Math Education).

The course accommodates the approximately 400 students by selecting laboratory teaching assistants from various humanities and social science departments. Some of these graduate students have considerable computer experience and some have never used a computer.

The students start with major application programs, such as word processing, data base management, spreadsheet, and communications, to become comfortable with the Mac and get some idea of what it can do. Then they move on to programming in MacPascal, learning a half-dozen fundamental programming concepts, including algorithms, loops, decisions, subroutines, and variables. The next step is modifying existing programs. The

course concludes with a project. Students work in groups of two or three with a teaching assistant from their own area of study.

The Macintosh was chosen, said Mark Bedau, a course teaching assistant from the Philosophy department, because it is good for beginners. Fundamental concepts such as file organization are easy to explain on the Mac, because it uses icons and a mouse. The graphics orientation of the Macintosh is also useful for teaching purposes, Bedau says. The graphics allow a more natural presentation of concepts, and screen shots are worth a thousand bytes. During the final weeks of the course, the students will use other computers and can choose to do their project on any available computer. It will be interesting to see how many switch to a less friendly computer.—Heidi Mitchell

Print It and Wear It

"If you can print it with your Mac, you can wear it on your back (or front)." So reads the "permanent press" release (it's printed on a T-shirt) announcing the advent of Underware, a ribbon for the Imagewriter that lets you turn your Mac art into iron-on transfers for T-shirts, banners, or any other material imaginable.

Underware is the product of Diversions, a Belmont, California, company that came into being, according to president Weldon Benedict, on Friday the 13th of July 1984 when Benedict and one of the other two principals were fired from their jobs at a software company. "We were sitting around talking about what we could do to make money on a low budget, and we came up with Underware," says Benedict.

Despite its unlucky birthday, Underware looks like a winner. At \$19.95 it prints at least 20 designs, and transfers have the

quality of commercial T-shirt prints. The Underware ribbon also works with the Apple Dot Matrix Printer, the NEC 8023, and the C. Itoh Prowriter. Contact Diversions, 1550 Winding Way, Belmont, CA 94002, 415/591-6739.

We have learned about two other firms that market products similar to Underware: Sharp Color, 400 N. High St., Box 175, Columbus, OH 43215, 614/221-0502; and The Reference Corporation, 212 Fifth Ave. #1312, New York, NY 10010, 212/685-4809.—Joe Matazzoni □



//////
A special ribbon for the Imagewriter allows you to make iron-on transfers of Macintosh designs. Remember to flip the design before you print it out; otherwise you'll have to stand in front of a mirror for anyone to enjoy it.

THE MOST REVOLUTIONARY ATTACHMENT TO THE MACINTOSH™ SINCE THE MOUSE.

The Bernoulli Box,™ the cartridge disk subsystem that revolutionized mass storage for the IBM PC, XT, most compatibles, and the TI Professional, now proudly adds Apple's Macintosh to the list.

The Bernoulli Box and its 5-megabyte removable cartridges together deliver unparalleled data base dynamics. And that, more and more, is what your business needs today. Not centralized, monolithic banks of information, but data bases defined by job function and software application. Data bases that give people the versatility to work more productively.

But there is more. More performance and reliability. Transfer rates and access times faster than most Winchester. No head crashes ever. And cost per megabyte that Winchesters cannot touch.

The Bernoulli Box's cartridge capacity, portability and absolute interchangeability give your business more options. You can easily build primary data bases. You can package individualized data bases, software and all—for payroll, accounting, marketing, computer graphics—in convenient, dedicated cartridges. And you can pack all of the data into a briefcase, an interoffice envelope, or even a file drawer.

The Bernoulli Box. When placed beside Apple's "computer for the rest of us," the best box you can buy. **For the dealer nearest you, call 1-800-556-1234, ext. 215. In California call 1-800-441-2345 ext. 215.**

OMEGA™

OMEGA CORPORATION
1821 West 4000 South
Roy, Utah 84067



THE
BERNOULLI
BOX™

Circle 171 on reader service card

For a price, this team will consolidate, calculate, format, sort, merge, retrieve, rebuild and report your data.

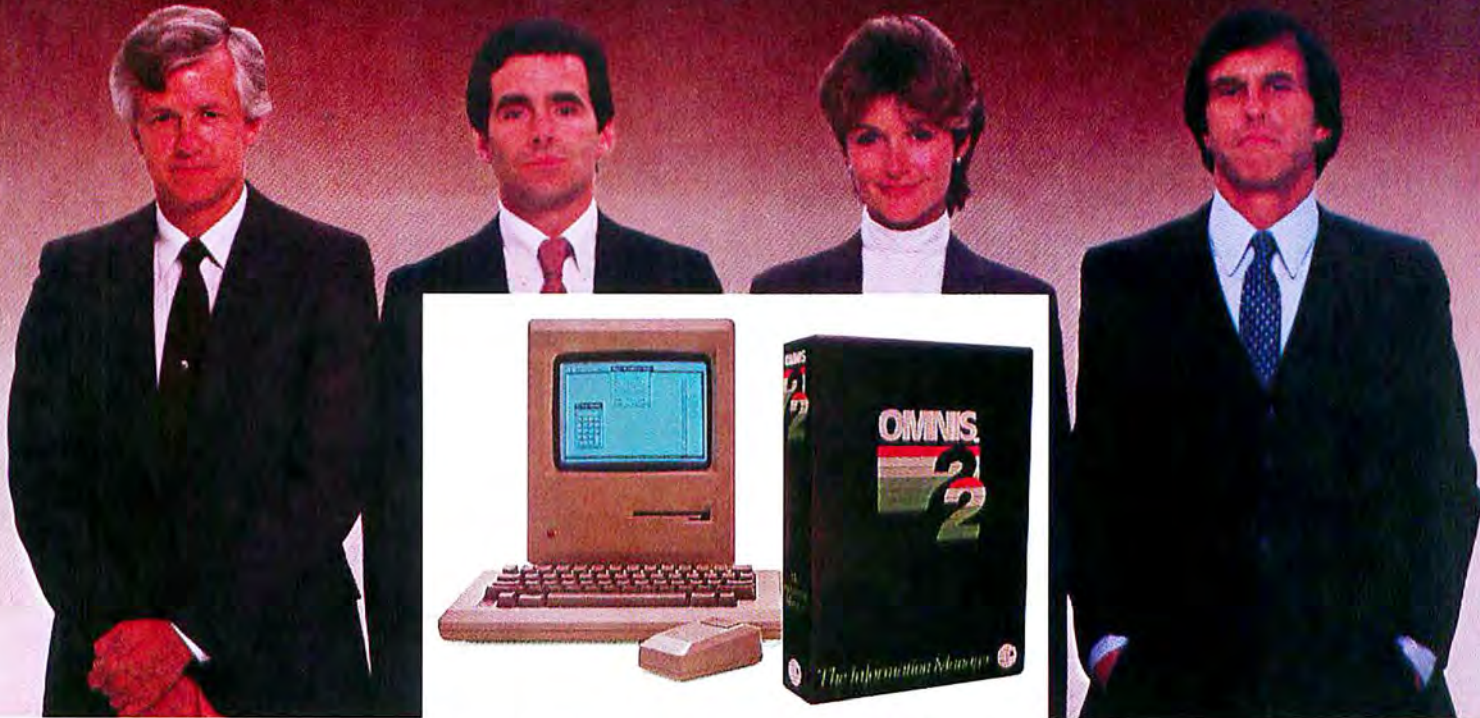

For a song, so will this one.

Introducing the most efficient management team in the business. OMNIS 2 and your Macintosh.™ Database software with the power to streamline your business. Now taking full advantage of Macintosh capabilities.

Like other good database programs, OMNIS 2 will help you organize information.

End similarity.

OMNIS 2 will calculate, arrange, store, sort, and retrieve your business data. Quickly. Update thousands of files all at once. Generate a complex report. Merge lists and letters. Help you make better decisions. All with a few clicks of the mouse. **Do it your way.**

OMNIS 2's incredible flexibility lets you manage data your way.

Click. The mouse pulls down the menu. And you're ready to create a custom database layout for up to 9600 characters and up to 120 information fields. Character fields. Click. Numeric fields. Click. Date, boolean, and sequential fields. Click, click.

OMNIS 2 lets you designate a full

array of calculations in up to 60 numeric and date fields. It's fast—you can enter and retrieve information in an instant. Even with thousands of records to search. Click. And OMNIS 2 lets you integrate data using Mac's calculator, scrapboard, and clipboard.

Need to reformat your layout? Do it whenever you want to. Even after entering data. Need to update records? OMNIS 2 handles multiple updates with ease. It even guards against improper data entry.



OMNIS 2 takes full advantage of pull-down menus and many other Macintosh features.

Need more than a database program? This is it.

A powerful report generator.

Creating lists and reports is a snap. Click, click. Personnel reports. Inventory updates. Financial statements. Sales data. Mailing lists. Labels. Data-merged

letters and documents. All per your unique, exact requirements. And all transferable to Macwrite.

OMNIS 2 will search using up to 50 fields at any one time, and sort data down to 9 levels. Complete with sub-

totals and up to 60 more calculations. Averages, "what if" scenarios. Whatever. **Upgrade to OMNIS 3.**

When you're ready to create your own applications programs—complete with custom menus—you can upgrade to OMNIS 3. It's an advanced relational/hierarchical program, supports up to 12 open files, and is file compatible with OMNIS 2.

If you don't own a Mac, the OMNIS family of database software is also available for Apple™ IIe, Apple IIc, Apple II+, Apple III, Lisa,™ IBM® PC and XT, Victor,™ Sirius,™ Apricot,™ DEC Rainbow,™ and more.

OMNIS 2, *The Information Manager*. Fully supported by OSC. And only \$195 to \$275 at your computer software dealer. Or order direct. Organizational Software Corporation, 2655 Campus Drive, Suite 150, San Mateo, CA 94403, (415) 571-0222.

OMNIS

Organizational Software Corporation

Circle 38 on reader service card

I N T E R M

Premiering the next generation.

H A R A

Background Highlights • Time Management • Database • Communications • Memowriter • File Management, and more!

A T R I X

NONNY™

The brilliant rhapsody of productivity tools and desktop performers that play in concert with all other Macintosh programs—simultaneously. The price for this grand ensemble of concurrent utilities? Under \$200... Bravo!



INTERMATRIX
5547 Satsuma Ave.
North Hollywood, CA 91601
(818) 509-0474

Circle 8 on reader service card

Reveal The Power Inside Your Macintosh™ . . .

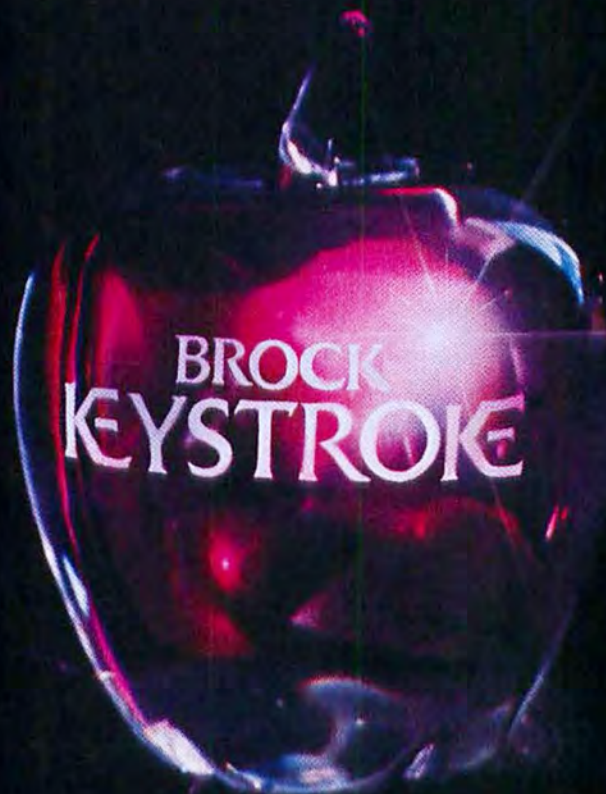

Brock Keystroke* Data Base And Report Generator

Advanced information management becomes crystal clear with the only software that mirrors the productivity potential of your Macintosh. . . Brock Keystroke Data Base and Report Generator.

The Keystroke electronic file cabinet enables you to STORE, FIND, UPDATE, or PRINT information with startling clarity. And only Keystroke has enlightened features such as field formatting, automatic repeat fields, default responses, rapid search/sorts, computed fields and cross-referencing. Plus, Keystroke's Report Generator directs the full power of the Data Base into printouts that conform to your exact needs, including flexible formatting, statistics, highlighting, computed columns, and more.

To reveal the full power inside your Macintosh, you don't need a crystal ball. Simply visit your Apple® dealer and ask for a Brock Keystroke demonstration. Or contact us directly for all the illuminating details.



Brock Software Products, Inc.
8603 Pyott Rd., Box 799
Crystal Lake, Illinois 60014
815/459-4210
Telex: 722-469 BROCK CRY

*A Symbol of Excellence By
Brock Software Products, Inc.



BROCK SOFTWARE
PRODUCTS, INC.

* Apple is a registered trademark of Apple Computer, Inc. ** Macintosh is a trademark of Apple Computer, Inc.

Circle 46 on reader service card

Give Mac a piece of your mind.



Inspiration is fleeting, so just let your thoughts flow. The flexible format makes it easy to rearrange them later into headings and a basic outline.



Use as many headings and as much text as you need to develop the outline fully. ThinkTank's processing power can move whole sections of text with a single keystroke—something no word processor can do.

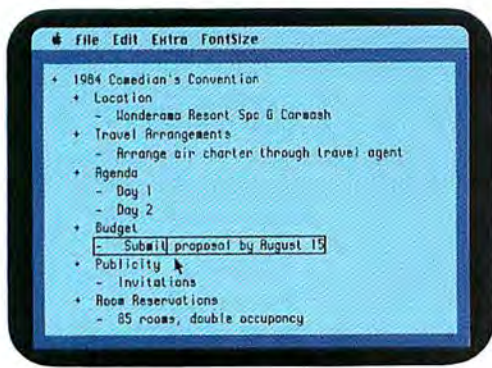

When you want to scope the Big Picture, a simple command drops out everything but the main headings. Subheads and detailed text are stored for recall later.

Go ahead.

Put your two cents worth onto ThinkTank.[™] And watch it grow into a million-dollar idea.

Because ThinkTank is the first software designed to process ideas. Now it's available on the Apple's Macintosh.

ThinkTank's flexible outline format lets you clearly see your idea from all angles. So you can sharpen up an inspired thought, weed out a weak one, set priorities, weigh alternatives.

It's like a spreadsheet for ideas.

While all this structuring helps your brain-child take shape, it won't inhibit the natural flow of creative juices. Because entering an idea onto ThinkTank is as easy as scribbling it on a cocktail napkin. All you need is simple English.

Just let your thoughts flow—from "pie in the sky" concepts to the "nuts and bolts" details. And build more professional proposals,

marketing plans, legal briefs, case reports, engineering specifications, research notes, action items, hot lists and to-do lists.

Call 1-800-556-1234 Ext. 213 (in Calif., 1-800-441-2345 Ext. 213) for the store nearest you. And see what's really on your mind.



The First Idea Processor.

"ThinkTank" and "The First Idea Processor" are trademarks of Living Videotext, Inc. © Copyright 1984, Living Videotext, Inc., 2432 Charleston Road, Mountain View, CA 94043, (415) 964-6300 Circle 50 on reader service card

A Face for All Seasons

James Felici and Evelyn Spire

You can print all the familiar Macintosh fonts on the LaserWriter, but you probably won't be satisfied with their appearance compared with the new fonts built into the printer's memory. Whereas the old library of Mac fonts was designed around the limitations of the Mac screen and the Imagewriter's printing capabilities, the new font library is based on professional type standards.

The LaserWriter is certainly an impressive combination of hardware and software. But what makes the printer truly useful is its selection of typefaces. Built into the printer's ROM are 13 typefaces, including representatives from the world of commercial typography: Times Roman, Helvetica, and Courier, as well as a set of mathematical and Greek characters for scientific writing. Times Roman and Helvetica are among the most popular commercial typesetting faces, while Courier is the face made famous by the IBM electric typewriter (see Figure 1).

The software that makes the LaserWriter's quality typefaces possible is the PostScript programming language, developed by Adobe Systems of Palo Alto, California (see "The Language that Talks to Your Printer"). But the key to this assemblage of hardware and software is the licensing agreement between Adobe Systems and the Mergenthaler Linotype Company. Mergenthaler is a leading international manufacturer of state-of-the-art typesetting equipment, and their type library of over 1300 faces is renowned for its quality. The adaptation of commercial typefaces represents a convergence of personal computer technology and a typesetting tradition that dates back to Gutenberg.

Faces, Fonts, and Families

Gutenberg's invention of movable type in the 1430s essentially put calligraphers and hand carvers of type out of business. It became the job of type designers to create the artfully crafted and readable typefaces that would be the successors to the hand-letterer's unique characters. This chore was and still is an exceedingly tedious one, calling for the creation of a family of some 60 or 70 characters that share a common design motif and proportional scheme, presenting a unified impression to the eye.

Creating a readable typeface is no mean feat, which is why only a limited number of such faces are available in type libraries. Many typefaces are several hundred years old; like the Garamond you are reading now, such typefaces have proven over time to be the most readable.

Typefaces are generally grouped into families, related by design similarities that allow them to be used together harmoniously. A font is a complete character set of a given typeface in a particular size. Members of type families are distinguished by two variables, the first of which is the weight, or thickness, of the strokes making up the letters. Thus a face can have several versions, such as light, regular (or book weight), demibold, bold, heavy, and extra bold (see Figure 2).

The second variable is character width. Variants on a face can be created by making the letters wider or narrower while keeping the same letter height. A condensed face has narrower characters, giving the letters a more vertical appearance. Conversely, an extended face has wider characters, which gives the type a squatter, more horizontal look. Condensed faces are commonly used in situations in which it's desirable to cram a lot of type into a small area, such as in ingredient lists on food packaging.

Most type families have two styles: roman, the "normal" style, like the type you're reading now, and italic, which is inclined to the right and resembles cal-



The LaserWriter contains 13 professional-quality typefaces. The characters in each font are stored in the printer in outline form (as simulated in this figure). This feature enables the LaserWriter to print its fonts in any size or rotation.

Figure 1
 Built into the Laser-Writer's ROM are 13 faces selected to cover a wide range of applications. Helvetica and Times Roman are among the most common faces used in commercial typography, and Courier is a standard face for business correspondence and word processing. In addition to the alphabets shown, each font contains numerals, punctuation, diacritical marks, foreign accents, and utility characters. Also built into the printer is a utility font that includes Greek, mathematical, legal, and decorative characters. All fonts are displayed here at 24-point.

Helvetica	Roman	abcdefghijklmnopqrstuvwxy ABCDEFGHIJKLMNOPQRSTUVWXYZ &
	Oblique	<i>abcdefghijklmnopqrstuvwxy ABCDEFGHIJKLMNOPQRSTUVWXYZ &</i>
	Bold Roman	abcdefghijklmnopqrstuvwxy ABCDEFGHIJKLMNOPQRSTUVWXYZ &
	Bold Oblique	<i>abcdefghijklmnopqrstuvwxy ABCDEFGHIJKLMNOPQRSTUVWXYZ &</i>
Times	Roman	abcdefghijklmnopqrstuvwxy ABCDEFGHIJKLMNOPQRSTUVWXYZ &
	Italic	<i>abcdefghijklmnopqrstuvwxy ABCDEFGHIJKLMNOPQRSTUVWXYZ &</i>
	Bold Roman	abcdefghijklmnopqrstuvwxy ABCDEFGHIJKLMNOPQRSTUVWXYZ &
	Bold Italic	<i>abcdefghijklmnopqrstuvwxy ABCDEFGHIJKLMNOPQRSTUVWXYZ &</i>
Courier	Roman	abcdefghijklmnopqrstuvwxy ABCDEFGHIJKLMNOPQRSTUVWXYZ &
	Oblique	<i>abcdefghijklmnopqrstuvwxy ABCDEFGHIJKLMNOPQRSTUVWXYZ &</i>
	Bold Roman	abcdefghijklmnopqrstuvwxy ABCDEFGHIJKLMNOPQRSTUVWXYZ &
	Bold Oblique	<i>abcdefghijklmnopqrstuvwxy ABCDEFGHIJKLMNOPQRSTUVWXYZ &</i>
Symbols		αβγδεζηθικλμνξοπρστυφχψωω ΑΒΓΔΕΖΗΘΙΚΑΜΝΞΟΠΡΣΤΥΦΧΨΩ ΠΣ = ≠ ≡ ≍ < > ≤ ≥ ^ ∨ - + ± × ÷ ≈ ~ ¬ ∞ ∞ ∴ ⊗ ⊕ ⊙ ∩ ∪ ⊃ ⊇ ⊆ ⊅ ⊄ ⊅ ∫ ∫ { ∩ } [∩] (∩) ↑ • ® ™ © ™ ♣ ♦ ♥ ♠ (∩) ↓ ↓ / ∅ ∇ √ ∫ ∂ () _ ∇ ∞ ∞ ∞ ∞ J { } ∩ U 0123456789 ° # % ' * " & ! ? : ; , ⇄ ⇆ ⇈ ⇉ ⇊ ⇋ ⇌ ⇍ ⇎ ⇏ ⇐ ⇑ ⇒ ⇓ ⇔ ⇕ ⇖ ⇗

ligraphic, or pen-drawn, characters. Some faces that lack true italic complements use inclined versions of the roman-style characters; these inclined versions are referred to as "oblique." Helvetica has such a face.

Typeface families can be quite extensive, consisting of both roman and italic faces that vary in both weight and character width. The complete Helvetica family, for example, includes 40 separate faces. Times Roman, on the other hand, has less than 10 family members.

Display and Body Faces

Each typeface, by virtue of the design characteristics of the individual letters, carries a subliminal message that influences the content of the words composed in its alphabet. Certain typefaces present a scholarly aspect, some are dramatic, and others have a scientific, informal, or jazzy look (see Figure 3).

Typefaces are divided into two main groups based on their dramatic and aesthetic qualities: display and body faces. Display type is usually reserved for headlines and advertisements. These typefaces are usually arresting in appearance, having been designed to stop and hold the eye (see Figure 4). Body, or text, faces are used for long passages of text in which readability is the primary concern; the reader's eye should be able to fly along at high speeds, recognizing instantly the letter forms and the words. For this reason, most body faces look similar to the untrained eye of the casual reader.

The fonts introduced with the LaserWriter printer offer flexibility and diversity. They can be used for both text and display purposes. As the library of fonts grows, we can look forward to the introduction of faces that have more specific text or display applications.

Serif and Sans Serif

An important division among typefaces has to do with the way the letters are drawn. Serif type is distinguished by the fact that the strokes making up the letters vary in thickness and by the presence of serifs, the small extensions at the ends of the strokes. Both of these features enhance the readability and aesthetic appeal of serif faces.

The LaserWriter serif face, Times Roman, designed for the *Times* of London in 1931, is the product of a concerted effort to use historical models to create a modern serif typeface of unsurpassed readability. The fact that Times Roman is now a publishing indus-



Figure 2
Selections from a family album: some representative members of the Helvetica family, illustrating the permutations possible through the variation of character width and weight.



Figure 3
Display faces are eye-catching—great for headlines, but not very useful for long passages of text, as in bulk they become difficult to read. Imagine trying to read a short story set in Mistral or Rainbow Bass.

Type Talk

The type terminology we use today is largely based on Gutenberg's original typesetting technology. In his system of movable type, each character was carved on the face of an individual, reusable block. These blocks were combined to form lines of text, and the lines stacked to form pages. In modern typesetting, these blocks no longer exist, but the old terms are still in use.

Point Sizes

The measurements most often used to describe type are picas and points. There are 12 points to the pica, and although there is no exact correlation between type measurements and either English or metric measurements, there are almost exactly 6 picas (hence 72 points) to the inch.

Type sizes are expressed in points, which refer to the height of the imaginary type block upon which the letter sits (see the figure "How Type Sizes Up"). This measurement is

roughly equal to the distance from the top of the ascender (that part of the *b* or *k*, for example, that extends upward) to the bottom of the descender (the lower stroke of a *y* or a *q*).

Leading

Because the original letter blocks were made of lead alloy, vertical distances in typography are referred to as leading. Leading is measured with regard to the base line, that invisible line upon which the characters sit.

To describe the type you want on a page, you must define both the size of the letters and the amount of leading. In magazine or book type, which generally ranges from 9- to 12-point, readability is enhanced by the addition of a point of extra lead between lines. This helps the eye find the proper line when moving from the right margin back to the left. On very wide pages, two or three extra points of lead may be necessary to help the eye locate the correct line when moving from margin to margin.

The type you are now reading is set in 10-point type on 11 points of lead, a formula expressed as 10/11, or "10 on 11." If you wanted to set type without extra leading, you would call for 10/10.

Letter Spacing

A major consideration in typographic aesthetics is the spacing between characters in a word. Although each face is designed with an eye toward harmony between character shapes and sizes, the type designer has little control over how the spacing between particular characters will affect the type's readability and balance. Character spacing, then, becomes a major concern for the typesetter. Ideally, each character in a word should nestle against its neighbors, giving the general appearance of even spacing between letters. However, owing to the different shapes of letters, that ideal is not always easy to achieve. Ad-

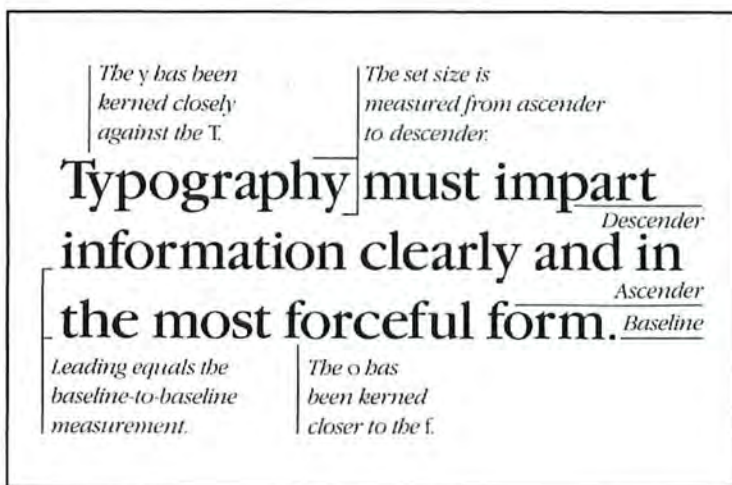

How Type Sizes Up

The basic terminology of modern typesetting is still based on the assumption that each character sits on its own lead block, although these blocks are now imaginary. Kerning, likewise, is based on the idea that the physical width of these blocks is an impediment to proper character spacing.

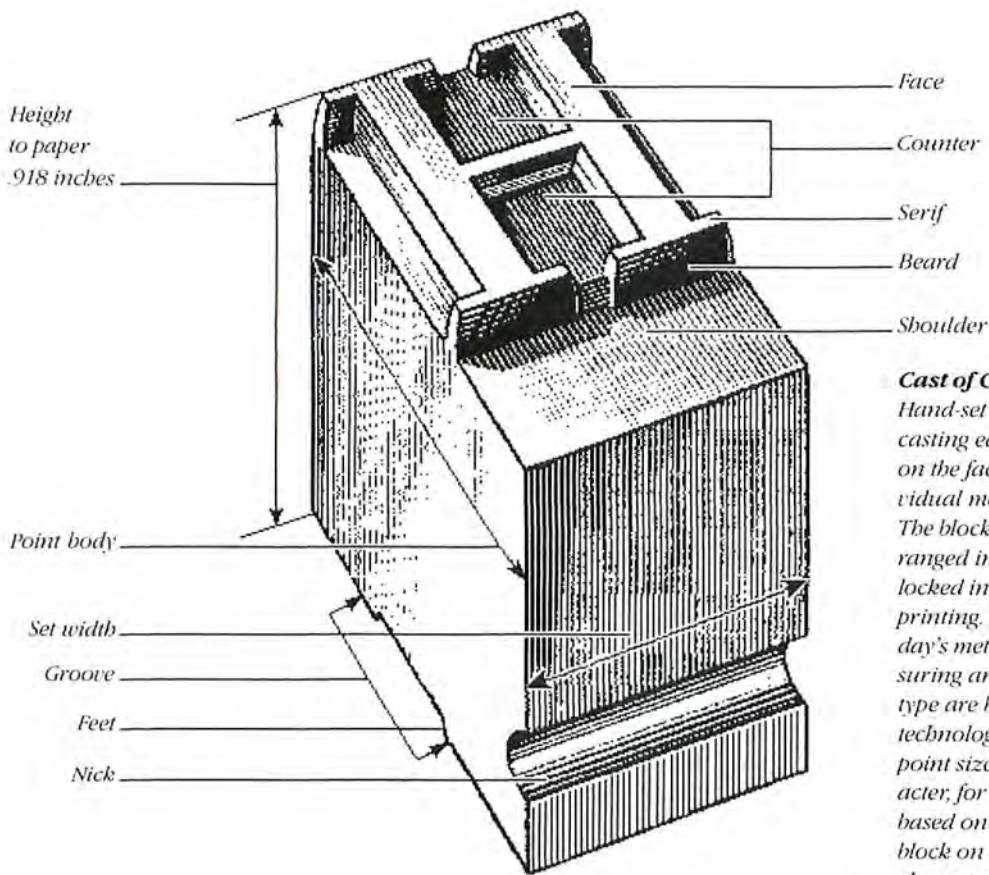

Cast of Characters

Hand-set type involves casting each character on the face of an individual metal block. The blocks are then arranged in rows and locked into place for printing. Most of today's methods of measuring and specifying type are based on this technology. The stated point size of a character, for instance, is based on the size of the block on which that character would be cast (see "Type Talk").

Adjacent round characters are apt to look too far apart, while adjacent flat or square characters (such as *l*, *i*, or *m*) may appear too close.

Some computer printers are equipped with a facility for proportional spacing, which takes into account the differences in widths among the letters of the alphabet. These machines create type that looks better than that of regular printers or typewriters, but since they still cannot space letters on a case-by-case basis (round letter to flat letter, flat to flat, round to round, and so on), they are limited in their ability to offer con-

sistently even letter spacing.

The Imagewriter, like most computer printers, assigns all characters, including punctuation, the same width, so that all typed characters on the printed page align in vertical columns, just like on the computer screen. The LaserWriter printer, by using Mergenthaler character widths, sets each character with the variable widths used in commercial type shops.

In the days of metal type, there was little the typesetter could do to adjust interletter spaces. Certain characters, though, were equipped with *kerns*, parts of a letter that ex-

tended off their own letter blocks and overlapped adjoining blocks. Part of the cross-stroke of a capital *T*, for example, might overlap the character to the right, so that a subsequent lowercase letter might nestle slightly into the white space around the *T*'s vertical stroke. Character kerning reduces the obtrusive white space between characters, creating a sense of uniform spacing. The ability to kern is what separates great type from good type.

Figure 4

Typefaces are expressive by themselves, and a good typographer becomes adept at matching a type style to the tenor of the text. Nicholas Cochin, for example, presents an old-fashioned, scholarly look, while Avant Garde has a modern look, lighthearted yet formal. *Craw Modern* is decidedly emphatic, *Optima* is light and elegant, and *Lubalin* is machine-like and precise. *Cloister Black* speaks for itself.

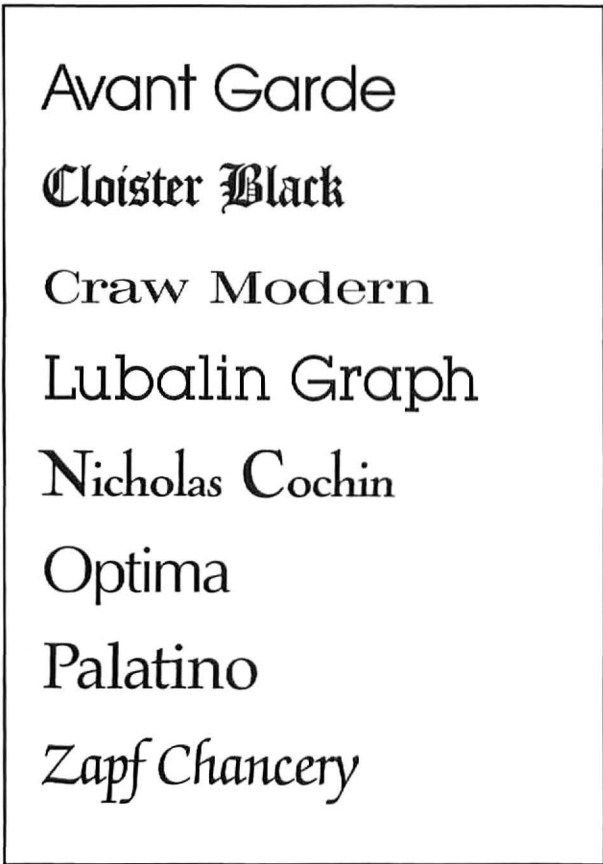

Figure 5

Times Roman is among the most legible and readable serif faces ever designed. The balance and proportion of its characters make it useful for both small type and large headlines.

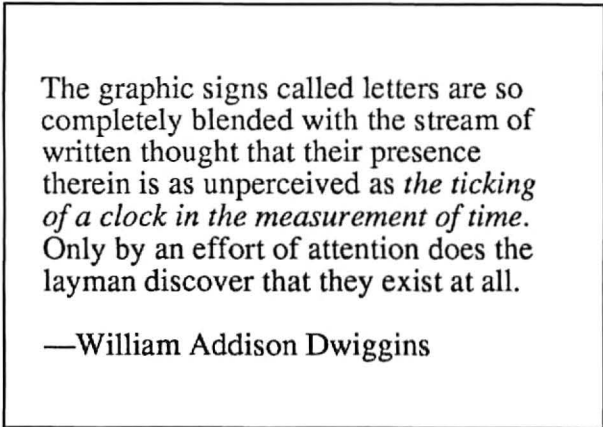
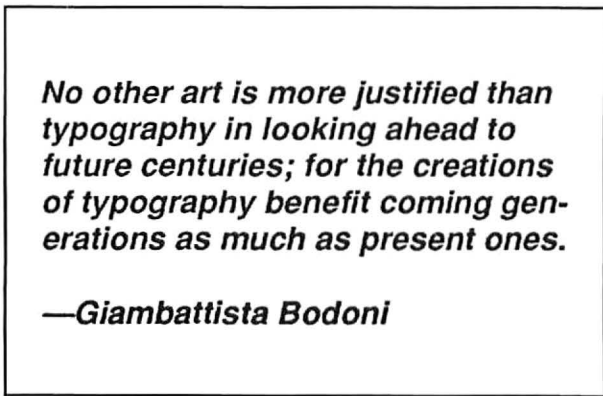

Figure 6

Helvetica is the darling of sign-makers and corporate logo designers because of its clean design, readability, and image of clarity and objectivity. Once you become familiar with the appearance of this face, you'll begin to recognize it just about everywhere.



try standard attests to the success of that endeavor. Times Roman is the text face used in *Newsweek*, *Sports Illustrated*, *Esquire*, *Personal Computing*, and *Fortune*, among others. Most proofreaders will tell you that Times Roman is the least fatiguing face to read (see Figure 5).

In contrast to serif faces, sans serif faces tend to have strokes of approximately equal thickness and lack the serif ornamentation. These faces have a modern, clean, architectural look that is readable from long distances—thus their appeal for use in signs and billboard advertising. The Laser Writer sans serif typeface, Helvetica, is modeled after faces designed in the 1930s at the Bauhaus school of design in Germany. Although Helvetica is readable in small sizes and is useful as a body type, you probably see it more often in corporate logos, parking lot signs, and government forms. You'll recognize Helvetica next time you see an ad for American Airlines, stop at an ARCO gas station, or fill out your income tax form (see Figure 6).

Courier, another typeface introduced with the Laser Writer, is not part of the Mergenthaler library. This square serif face was originally designed as a typewriter face and is used in office and business applications. Whereas office printing technology has often sought to imitate typeset faces, this, ironically, is a case of typesetting technology imitating the look of an office printer.

In the coming months, Apple will undoubtedly offer new Mergenthaler faces for the Laser Writer, including Palatino (serif), Avant Garde (sans serif), and Zapf Chancery (calligraphic). You'll be able to download these fonts into the printer's memory, and place equivalent screen fonts in the System file of your application disks. The Laser Writer's increased resolution, PostScript's sophisticated font creation capabilities, and Mergenthaler's professional fonts create a true typesetting environment—a marriage of personal computing and commercial typography. □

■■■■■■■■■■ James Felici is the Production Editor of *Macworld* and *PC World*.

■■■■■■■■■■ Evelyn Spire is a freelance writer and editor based in San Francisco. She currently edits for *PC World Books/Simon & Schuster*, *Hayden Book Company*, and *Tri-Athlete* magazine.

MegaMerge is here!



Megahaus proudly introduces MegaMerge...one of their many software products for the Macintosh that's available right now!

MegaMerge works hand-in-hand with Apple's MacWrite to:

- Create full mail list merging
- Print your mailing labels
- "Chain" your documents together so they print as one long document

With MegaMerge and MacWrite working hand-in-hand, you'll also be able to print hundreds of form letters to everyone on your mailing list and include standard "boilerplate" in all your contracts, letters, reports and other documents.

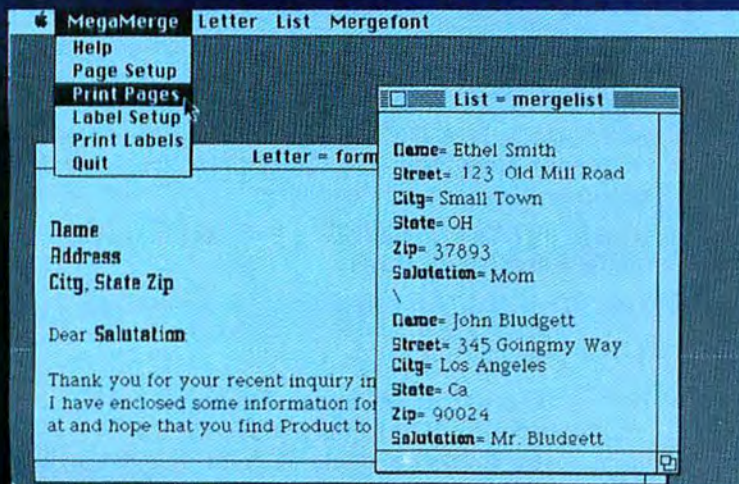

Circle 86 on reader service card

Chances are, if you now own Apple's Macintosh, you'll already have MacWrite. So why not take full advantage of Macintosh's technology with MegaMerge right now?

MegaMerge will work wonders for the Macintosh... and your business.

We'll even shake on it.



Megahaus has an entire family of software products for the Macintosh!

megahaus
WE MAKE COMPUTERS WORK HARDER.

Circle

5703 Oberlin Drive, San Diego, CA 92121/Phone (619) 450-1230

Does Income Tax Time Tax Your Patience?

Mac In Tax™

The Income Tax Program For Individuals

The screenshot shows the 'Forms' menu with the following options: Form 1040, Schedule A, Schedule B, Schedule C, Schedule D, Schedule E, Schedule F, Schedule G, Schedule H, Schedule I, Schedule J, Schedule K, Schedule L, Schedule M, Schedule N, Schedule O, Schedule P, Schedule Q, Schedule R, Schedule S, Schedule T, Schedule U, Schedule V, Schedule W, Schedule X, Schedule Y, Schedule Z, Form 2119, and Form 2441. The '1040' form is selected and highlighted.

The screenshot shows the 'Name & Address Instructions' dialog box. The text inside reads: "Please use the mailing label from the forms booklet we sent you. If you did not receive a booklet with a label, print or type your name and address." There are fields for "Name", "Address", and "City, town or post office, State, ZIP code". A "Print" button is visible.

- TAX FORMS APPEAR ON SCREEN** — select any form from the menu, an image of the form appears. Separate windows for each form.
- POINT AND CLICK TO ENTER AMOUNTS** — selected lines are highlighted. Amounts can be entered, changed or cut-and-pasted from the calculator.
- TAX CALCULATIONS PERFORMED AUTOMATICALLY** whenever an amount is entered. The results appear immediately on screen.
- IRS INSTRUCTIONS IN SEPARATE WINDOWS** — the complete IRS instruction booklet available — double-click on a line to see the instructions for that line.

- WORKSHEETS AVAILABLE FOR EACH LINE** — double-click an amount to use the IRS worksheet or to itemize — the total is computed automatically.
- PRINT AMOUNTS DIRECTLY ONTO IRS FORMS** — or print replicas of the forms and amounts on blank sheets of paper.
- SAVE AMOUNTS ON DISK** for future use — all amounts, including worksheets and itemizations, stored on disk — separate files for each taxpayer.
- USE FOR TAX PLANNING** — enter estimates to project present and future taxes.
- YEARLY UPDATES** available for a nominal fee.



SOFTWEAVE

400 MOBIL AVENUE BLDG. D, SUITE C • CAMARILLO, CA 93010 • (805) 388-2626

This product is tax deductible.

Circle 186 on reader service card

To order, send check or money order for \$70 to SoftWeave Co., or see your local dealer. Dealer inquires invited.

\$70

MegaFiler is here!

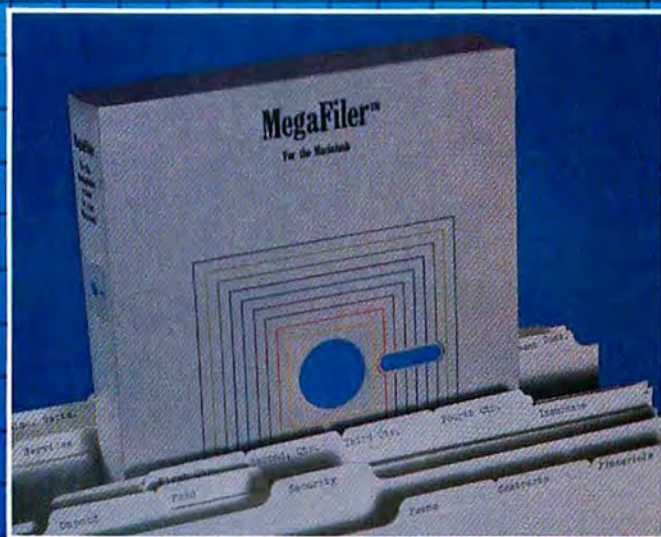

If you own, or are about to purchase an Apple Macintosh, then you'll definitely want MegaFiler from Megahaus Corp.

MegaFiler takes **full advantage** of Macintosh technology from "A" to "Z" which, in turn, helps you create a file management system second-to-none!

MegaFiler will give you:

- Full windowing capabilities
- Total use of desktop accessories
- Complete and accurate editing commands
- Multiple file access
- Complete hand-in-hand compatibility with Apple's Macintosh

MegaFiler also comes with a complete library of ready-made files that will provide a myriad of applications such as:

- Mailing lists
- Sales records
- Business inventory
- Home inventory
- Stocks
- Customer orders

In addition:

- Its 'file designer' lets you create your own custom files that can contain virtually unlimited fields arranged in any way you like!

- It works with our own MegaMerge, MegaForm and Apple's MacWrite to create alphabetized mailing lists and forms!
- You'll have access to full searching and sorting capabilities!
- You'll have multiple file access!

When you consider all of the MegaFiler benefits, doesn't it make you wonder how you could even get along without MegaFiler? Why not call the Apple dealer nearest you for a complete demonstration.

He'll make a believer out of you.

Megahaus has an entire family of software products for the Macintosh!

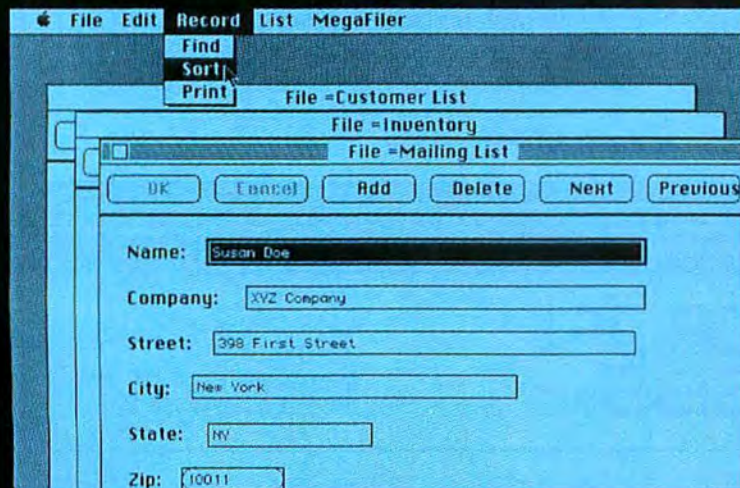

megahaus
WE MAKE COMPUTERS WORK HARDER.

Circle 87 on reader service card

5703 Oberlin Drive, San Diego, CA 92121/Phone (619) 450-1230

MITE Lets Your Macintosh Really Communicate!

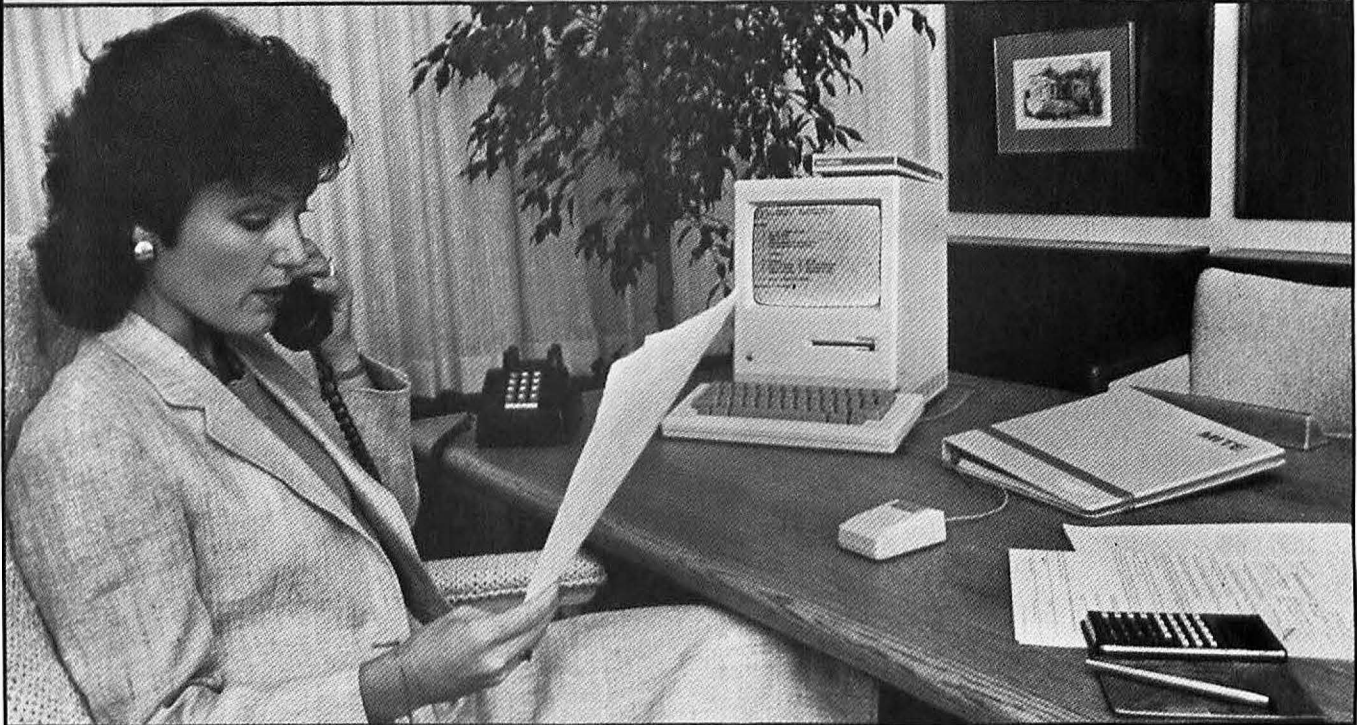

Is the Sales Report Ready? Then "MITE It To Me!"

With MITE, the industry's most powerful and easy-to-use data communications program, the world of online information is as close as your Macintosh. With the power of MITE you can automatically log-on and download information from your favorite information service. MITE takes full advantage of the Macintosh user interface, including pulldown menus, mouse control of all commands and complete access to the Macintosh Desk Accessories. MITE supports several different error checking protocols including the industry standard XMODEM protocol. MITE is fully

compatible with Apple's MacTerminal program, and it will allow you to transfer any Macintosh file with another Mac or any other computer for which MITE is available. MITE will even translate TEXT file formats to CP/M or MSDOS during a protocol file transfer.

MITE is also available for over 130 different computer systems including the IBM PC/XT/AT/jr, AT&T 6300, Sanyo 555, Tandy 2000, and Kaypro.

The suggested list price of MITE for the Macintosh is \$145.00.

Dealer and Distributor inquiries are encouraged

Macintosh and MacTerminal are registered trademarks for Apple Computer

Physical Address:
2615 North Monroe Street
Tallahassee, FL 32303

**MYCROFT
LABS INC**

Mailing Address:
P.O. Box 6045
Tallahassee, FL 32314
Telephone (904) 385-1141



HOW TO UNSCRAMBLE YOUR NEST EGG.

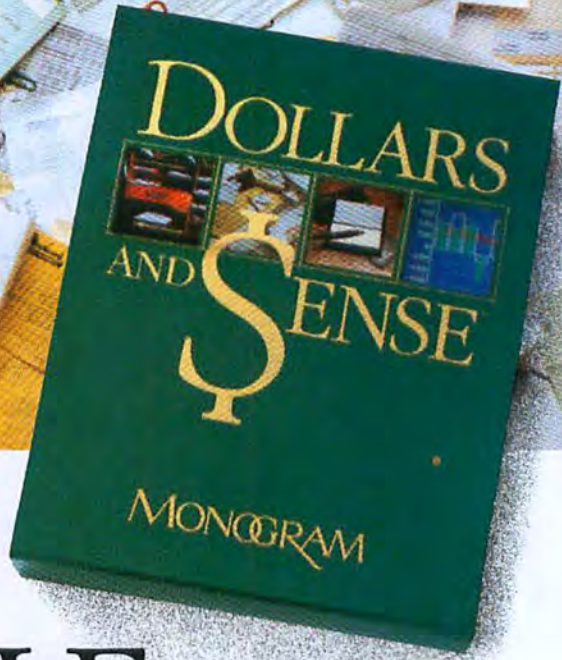

It doesn't take a computer to tell you that money can't buy you happiness.

But there is a piece of best-selling personal computer software that can make you a lot happier about your money.

And you're looking at it.

Making sense of your dollars.

Dollars and Sense™ saves you money by organizing your money. By giving you the clearest picture you've ever had of your financial behavior.

It defines budgets along any lines you like. Monthly or annually, fixed or variable. On up to 120 accounts.

It can write checks, make transactions automatically, even remind you to pay your bills.

And as time goes by, it tells you precisely how you're doing. With a complete set of reports and full-color graphs* that come up on screen or print out on paper. At the touch of a key.

And all you have to do is spend a few effortless minutes each week telling your personal computer** what came in and what went out.

Many happy returns.

You can use Dollars and Sense around the house or around the office.

And around April 15 you'll be glad you did. Because a few simple keystrokes will provide you with all the information you need to settle up with Uncle Sam.

Since your tax liability tomorrow is affected by the decisions you make today, Monogram will soon be introducing a new program, called FORECAST.™

With Dollars and Sense and FORECAST, you'll be able to estimate your taxes for up to five years. Or look at this year and ask "what if?" up to five different ways.

To keep Uncle Sam from raining on your parade.



Macintosh™ version in stores now.

MONOGRAM

8295 South La Cienega Blvd., Inglewood, CA 90301 (213) 215-0529

*Color monitor required. Graph printing may not be available on Apple® II series.

**Available for Apple IIe, IIc and Macintosh. Also available for IBM® PC, PC XT, PCjr and compatibles, the TI Professional and other popular personal computers.

Circle 77 on reader service card

Get Info

Macworld's tutor answers questions about using the Mac

Lon Poole



Get Info answers questions about the Macintosh and how it works. Most inquiries deal with application programs, but no topic is too elementary or too advanced. Discussions range from setting up the Mac to programming in BASIC and Pascal. When you need advice about using the Mac, drop me a line. I cannot respond to individual letters, but I will answer the most representative questions.

This month's *Get Info* includes the answer to an often heard query from intrepid Mac owners: Can I run my Macintosh off car batteries? Another person wants to know about the usefulness and compatibility of Motorola's 68020 microprocessor as an eventual replacement for the Mac's 68000. One reader wants an explanation of some of the less obvious *MacPaint* shortcuts and the Print Catalog command. Another person is looking for a Macintosh word processing program that has cursor key assignments. And a

number of people have written in with questions about creating special fonts, such as scientific and mathematical symbols or foreign alphabets, and adding them to the System file.

Battery-powered Mac

Q. My summer home in Vermont has no electricity. Is it possible to somehow power a Macintosh with car batteries?
*Jeff Broadbent
East Calais, Vermont*

A. The Mac is designed to accept the 120-volt alternating current that usually comes out of power outlets in residences or business offices. Car batteries produce 12-volt direct current and as such cannot power the Mac. However, George Crow, Analog Manager of Apple's Macintosh Division, points out that by purchasing an inverter, a device designed to transform electrical current from one form into another, you should be able to power the Mac off car batteries. Make sure that the inverter produces power between 95 and 120 volts rms

(root mean square). The Mac can accept alternating current within this range.

The Mac is also designed to accept current in a sine wave form rather than a square wave form. Sine wave inverters are rather expensive, but inexpensive square wave inverters can be used if there is a sufficiently slow transition between the negative and positive alternation in the flow of the electric current. If these transitions occur too quickly the Mac's line filter capacitors could draw excessive current and heat up. However, this situation is unlikely to cause a problem because the inverter is likely to fail before the capacitors do. Most inexpensive square wave inverters contain transformers that produce comparatively slow voltage transitions. So you can attach your Mac to a car battery through an inexpensive square wave inverter without damaging your computer or losing data.

MacPaint Shortcuts

Q. There are a few items in *MacPaint* that I can't find reference to in my *MacPaint* manual. First, choosing the Short Cuts option from the Goodies menu displays a keyboard diagram overprinted with various commands (Constrain, Undo, and so forth). How do the keys that change the font and font size work? Why are the right-hand Shift and Option keys marked with ellipses? And what does the Print Catalog command in the File menu do?

*Richard W. Brigg
Moonie Ponds, Victoria
Australia*

A. In *MacPaint* you can use the \mathbb{C} key and the Shift- \mathbb{C} key combination with the comma and period keys to change fonts and font sizes, respectively. The symbols < and >, the uppercase symbols on the comma and period keys, suggest the direction of the font or font size scrolling; for example, pressing \mathbb{C} -period changes the

selected text to the next larger font size. To move in reverse to a smaller font size, you press \mathbb{C} -comma. Pressing Shift- \mathbb{C} -period changes text to the next font in the sequence, and pressing Shift- \mathbb{C} -comma changes text to the previous font in the sequence.

The Shift and Option keys on the right side of the keyboard perform Constrain and Copy functions, respectively, like their counterparts on the left side of the keyboard. On the keyboard map displayed by the Short Cuts option, the keys on the right are not labeled with words because there isn't room. (All the keys on the left end of the keyboard map are elongated to accommodate the words.)

The Print Catalog command prints miniature versions of all the *MacPaint* documents on a disk. This feature provides a visual directory of your documents. The documents are drastically reduced, so you can

discern only their major features. On an 8½- by 11-inch sheet of paper, five miniatures fit in a row across the page, and there can be up to five rows. Only those *MacPaint* documents on the disk for which the *MacPaint* application was opened are included in the catalog. If you want to print a catalog of the *MacPaint* documents on a different disk, you must quit *MacPaint*, copy the *MacPaint* program to the disk you want to print from, open *MacPaint* from that disk, and choose Print Catalog.

68020 Microprocessor

Q. Recently I read about the development of the Motorola 68020 chip, a new member of the 68000 chip family. The chip is supposed to be very fast and compatible with the rest of the chips in the family. Since the Mac uses a 68000 chip, does this mean that someday we could see a 68020 "Super Mac"? And is it possible to replace my existing Mac's 68000 chip with a 68020 chip?

*Scott C. Meeker
Madison, Wisconsin*

A. The 68020 microprocessor is being developed by Motorola but it is not known whether it will be used in some future version of the Macintosh.

Theoretically the chip could replace the 68000 chip in the Mac. The chief advantage of the 68020 chip is that it can process information about four times as fast as the 68000. The processor's speed is a combined result of the chip's faster internal timing, a true 32-bit data path instead of the 68000's 16-bit data path, and a built-in 256-byte buffer. The buffer augments the 68020's speed because it allows the processor to check for incoming data less frequently so that the processor can concentrate on crunching data.

For several reasons, you can't simply replace the 68000 chip on the Mac with a 68020. One reason is that the 68000 is soldered into place and cannot be replaced like a socketed chip can. Another reason is that the 68020 has nearly twice the number of pins (which carry power and information between the microprocessor and the rest of the computer) as the 64-pin 68000. The difference in number and the fact that the pins are set into the Mac's digital board in a different way (the 68000 uses dual in-line pins whereas the 68020 uses a pin-grid array) would require a completely redesigned digital board for the Mac. You also can't replace the 68000 with a 68020 because the timing difference between the two microprocessors could cause some software to execute improperly.

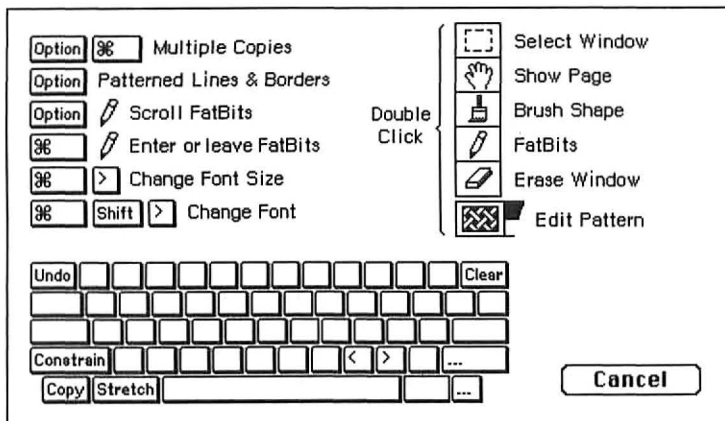

Short Cuts

The *Short Cuts* option in the Goodies menu shows the key combinations that let you scroll through the various fonts and font sizes.

For some time, any Mac upgrade will probably not involve replacing the 68000 chip. One of the main reasons for using a powerful microprocessor is that high-resolution graphics require the computation of a large amount of information. The 68000 processor is perfectly mated to the Mac's screen. Unless a display more advanced than the present one were installed, the improved performance of the 68020 wouldn't be that noticeable.

If a future version of the Macintosh is built with the 68020, modifications to the digital board will be necessary and economies of scale will have to be met. Before the 68020 could be used in a future Mac, sufficient quantities of the chip would have to be available to match the Mac's production rate. Also, the price of the chips would have to come down. The 68020 now costs \$500 while the 68000 chip costs less than \$20. The cost of a Mac with a 68020 chip would be prohibitive.

A Macintosh based on the 68020 should be able to run current Mac software. According to Burrell Smith, who as Hardware Wizard at Apple designed the Mac's digital board, the 68020 chip demonstrates Motorola's commitment to continue the development of the 68000 chip design. This commitment means that computers presently based on the 68000 can be improved and expanded without jeopardizing consumer investment in software.

Cursor Keys

Q. As an experienced word processor I have used a variety of word processing programs, such as *WordStar* and *Microsoft Word*. Recently, the company I work for traded in its IBM Personal Computers for Macintoshes. I like the Mac's friendly user interface and high-resolution graphics, but using a mouse instead of cursor keys for word processing has slowed me down considerably. Is there any Mac word processing program that uses cursor keys?

*Anne Dickson
Larchmont, New York*

A. At present I know of only one Macintosh program that has cursor keys to supplement the mouse—*Microsoft Word*. The beta-test version I used included a wide range of cursor key assignments that should satisfy the keyboard-bound fingers of experienced word processors. The program uses a diamond configuration on the right side of the keyboard. You need the left side free for the \mathbb{N} and Option keys, which must be used in combination with other keys to produce cursor movement. The J, K, L, and ; keys in the middle row used in combination with the \mathbb{N} and Option keys correspond to the following cursor position movements: J, word left; K, character left; L, character right; and the semicolon key, word right. The keys directly above the aforementioned keys move the cursor as follows: O moves the cursor up one line, P

FLUENT FONTS

This ad created entirely with FluentFonts™
Shown at half actual size

↩ Two-Disk Set ↩

A NEW CAST OF
CHARACTERS

FOR Word Processing
AND GRAPHICS

A Variety of Text Fonts

Enhance your Documents

Beautify Your Text Files

Graphic Arts Fonts

FANCIFUL FONTS
INNOVATIVE

BOLD FONTS!

USEFUL FONTS
DISTINCTIVE FONTS

Many New
GLOSSY FONTS

FONTS FOR SPECIAL APPLICATIONS

Right-to-left word processor not included

Circuit Symbols

WORD PROCESS IN RUSSIAN
ЭЛЕКТРИЧЕСКИЙ
or in CZECH with pravép áccèntš

FONTS FONTS FONTS
THERE'S EVEN A VERY TINY FONT FOR CAPTIONS AND LABELS

Tell Your Story

WITH STYLE AND VARIETY

Casady Company

P. O. BOX 225779 • CARMEL, CA 95922

OR CALL FOR VISA OR MC ORDERS

(408) 646-4660

Two-Disk Set \$49.95

+ \$3.00 shipping. CA res. add 6% tax

Name _____

Address _____

City, State, Zip _____

Phone _____ Visa MC Check

Card# _____ Exp Date _____

Signature _____

Fluent Fonts is a trademark of Casady Company

Circle 165 on reader service card

We've Learned One Thing About Macintosh™ Users . . .

They're people who see the "big picture." They see beyond the obvious, beyond the routine facts and details. While others dream, they design. Others take on a day at a time. Mac users take on tomorrow. And they use the Macintosh to put their ideas, imaginations, and vision into words and pictures. So that others can see what they see.

That's why we built the Mentaauris Composite Video Adaptor, specifically designed for the Apple Macintosh and featuring our exclusive Mac-Spansion Slot Technology™. With the Mentaauris CVA, your Mac connects perfectly with a wide range of commercial video monitor and projection equipment. Our CVA is lean, powerful, affordable, easy to install and operate, completely self-contained, and employs state-of-the-art electronics and engineering design. Much like the Macintosh itself.

The Mentaauris CVA, built for Mac users who see the "big picture." And who need others to see it, too. Because sometimes, others need all the help they can get.

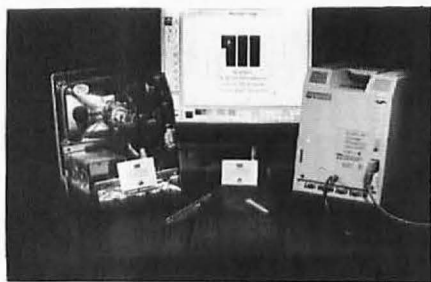

Mentaauris CVA and MacTools

™ P. O. Box 1467
San Marcos, TX 78666
Mentaauris (512) 396-1565
(formerly Mentaaur Technologies)

Macintosh is a TM licensed to
Apple Computer Inc.

scrolls up one page, and the left bracket key scrolls up one line. On the bottom row, the comma key moves the cursor down one line, the period key scrolls down one page, and the slash key scrolls down one line. In addition, *Word* also uses the quotation mark key in combination with the ⌘, Option, and Shift keys to select text and move the cursor in additional ways. Holding down the ⌘ and Option keys while pressing the quotation mark and J keys, for example, moves the cursor to the beginning of a sentence.

The Domain of Fonts

Many scholars, including mathematicians and linguists, have asked me about obtaining scientific and foreign language fonts that they can put in the System files of their application disks with the Font Mover. I hope the following information sheds some light on the subject.

Several fonts, including Cyrillic, Hebrew, Greek, and the Princeton Math Font, are available commercially or as public domain software. In fact, most Macintosh user groups offer a disk containing a variety of useful fonts. Many special fonts academicians seek can be downloaded from The Source or CompuServe. The fonts should be compatible with the

Font Mover, which enables you to move them in and out of the System file.

If you need to create your own fonts, a font editor has been available in the public domain for several months. This resource editing utility was originally designed by Apple for certified software developers, but most user groups offer the utility on disk. The font editor doesn't have any formal documentation and has some strange quirks, so you'll need to experiment or get some advice from someone who has managed to master its idiosyncracies. An improved version of the font editor has started to appear that makes the process of font creation easier than before. Check with your local user group or log on to CompuServe or The Source for the most up-to-date information.

Send your questions to Get Info, Macworld, 555 De Haro St., San Francisco, CA 94107.

Lon Poole is a Contributing Editor of Macworld and the author of several computer books including The Apple II User's Guide and MacWork/MacPlay. □

It's easy with Factfinder.™ Because Factfinder is a kind of electronic "desk-drawer" where you can just toss information without worrying about how it should be arranged or how you might want to use it. There are no fields to define, no formats to set up.

When you need to find all the clients you have who hate olives or live in Denver; when you want to collect your notes on pasta merchandising; when you need the name and number of that guy who's looking for leveraged buyouts, it's yours in a few seconds, at your index fingertip.

You just key in your notes on the Needleman Plan (or Needleman vs. Nardoff or the Needleman Noodles campaign) in any length you want, and click the mouse on a



few key words—"fallout," "bail out," "roll-out," "leveraged buyout," whatever. Then, any of those words or part of those words will bring you a stack of notes you've made that include "Needleman," or "leveraged buyouts," "national rollouts" or miracle "bail-outs." Or you can request Factfinder to get you the Factsheet that contains "Needleman" and "bail-out." Or you can ask for anything that mentions "bail-out" or "Needleman."

And Factfinder has all kinds of features like zoom and automatic wrap to help you manipulate the heck out of your data, and make it whatever size and shape you want.

Contact your Macintosh™ software dealer, or call 1 800 MACWARE to find out where you can get Factfinder. From Forethought, Inc.



MACWARE™

How to find a Needleman in a haystack.



© 1984 Forethought, Inc.
Factfinder is a trademark of Fact Finder Software, Inc.
Macintosh is a trademark of Apple Computer, Inc.

Circle 114 on reader service card

UCSD PASCAL DOES IT AGAIN!

The good news is now you can write your Apple™ applications in the language programmers love — choosing the development environment that works for your needs. UCSD Pascal® The Original, fully developed industry standard is now available in two versions designed specifically to run on the Apple™ Macintosh™. SoTech Microsystems makes it all possible by creating the best of all worlds — CHOICES. Depending on your needs, you have available the p-System development

environment or the MAC development environment. Either system allows you to write and execute compiled, UCSD Pascal programs on the Macintosh without fuss or complications.

The p-System for the Macintosh offers UCSD Pascal, with extensions to interface with a set of popular Macintosh features, a useful set of development utilities, a full function screen editor and a file manager. If you're familiar with the p-System or Apple Pascal you'll feel right at home with this product. FORTRAN-77 is also available.

Our compilers generate compact code allowing you to write complex applications on the 128K MAC. Plus, our languages are truly integrated with the development environment.

Edit with ease. When an error is detected while compiling, the editor may be invoked and positioned at the statement in error. For the first time, professional programmers now have available a full set of advanced development tools, including a 68000 Assembler and a symbolic debugger.

Want to run totally under the Mac environment? We provide a development system that does. It includes a mouse-based editor, a UCSD Pascal compiler, and program development utilities that operate totally in the Macintosh OS environment. Our UCSD Pascal compiler offers a compiled language that runs on a 128K machine. In addition, your applications can have a total Macintosh interface.

What does that mean to you? Access to virtually all Mac ROM routines. Overlapping windows. Pull-down menus. the Clipboard. Desk Accessories. And, of course, the mouse!

You'll find that UCSD Pascal goes MAC. And a lot of other places too.

SOFTTECH
MICROSYSTEMS

SoTech Microsystems, Inc.
16875 W. Bernardo Drive
San Diego, CA 92127
(619) 451-1230

Mail to:
Customer Sales and Support
SoTech Microsystems, Inc.
16875 W. Bernardo Drive
San Diego, CA 92127

Please send me more information on your Macintosh products.
 MAC p-System Development Environment
 MAC Development Environment

Name: _____

Title: _____

Address: _____

City: _____

Telephone: (_____) _____

Area of Activity

- Commercial Developer
 Fortune 1000
 Retailer
 Educator

- Personal Use
 Student
 Other

State: _____

Zip: _____

11/84

NOW 2 WAYS TO GO MAC

UCSD Pascal is a registered trademark of the Regents of the University of California.
Apple is a trademark licensed to Apple Computer, Inc.
Macintosh is a trademark licensed to Apple Computer, Inc.

Circle 84 on reader service card

LETTER QUALITY PRINTING FOR YOUR MACINTOSH™

with

ProPrint™

Now Supports . . .
Multiplan, Think Tank
and others

Now Features . . .
Proportional Spacing
Headers / Footers
Decimal Tabs



CDI's **ProPrint** is the MOST COMPREHENSIVE letter quality program for the MAC on the market today! You can prepare professional letters, reports and documents from your MacWrite™ files on all popular letter quality (serial) printers:

Abati	Brother	Diablo	Qume	TeleVideo
Amdek	C. Itoh	Dynax	Silver-Reed	Transtar
Apple	Comrex	Juki	Star Powertype	Xerox
Blue Chip	Daisywriter	NEC	Smith Corona	H.P. LaserJet

ProPrint is

—**Versatile**, formatting includes

- Proportional Spacing
- Underlining
- Bold face
- Superscript
- Justification: Right, Left, Center, Full
- Headers/Footers
- Subscript
- Ribbon color change
- Tabs; Decimal tabs

—**Multi-Tasking**

- Allows user to simultaneously
 - 1) Print document(s)
 - 2) Use desk accessories
 - 3) Select additional files for printing
 - 4) Monitor and control printing status

—**Easy to use, yet POWERFUL:**

- Mouse driven, uses pull down menus
- Auto loads and prints up to 50 files
- Single or multiple copies
- Auto default to most recent printer settings upon start up (no need to reload printer specs before each use)

—**Fully warranted for one year**

—**Available for immediate delivery**

ProPrint	\$ 74⁰⁰
ProPrint with cable.....	\$ 99⁰⁰
ProPrint with A/B Switch and 2 cables	\$225⁰⁰



Creighton Development, Inc. 4931 Birch Street, Newport Beach, CA 92660
(714) 476-1973

TM—Macintosh is a trademark licensed to Apple Computer, Inc. ProPrint is a trademark of Creighton Development, Inc. MacWrite is a trademark of Apple Computer, Inc.

Circle 64 on reader service card



The Prodigy Comes Of Age!

ExperLogo for the Macintosh™ is a powerful, many faceted version of the Logo computer language originally introduced in the late 1960's. ExperLogo excels as the patient tutor for those being introduced to computers for the first time, while at the same time it serves as a powerful development tool for the skilled programmer. Taking full advantage of the simplified user-interface characteristics of the Macintosh, Experlogo is easier to use than any previous Logo.

ExperLogo's innovative features include:

- ▶ 2-D, 3-D and Spherical Graphics
- ▶ Compiled Speed
- ▶ Powerful Data File Input/Output Capability
- ▶ Ability to Process Data Using Arrays
- ▶ Expanded Set of List Processing Primitives
- ▶ Friendly Mac-like User Interface
- ▶ Easy Access to the Macintosh Toolbox

The speed, combined with other advanced features that eliminate memory constraints and provide for sophisticated data file manipulation, are some of the reasons ExperLogo is now ready to assume the additional role as a serious program development language.

ExperLogo embodies power and versatility while retaining Logo's original virtues of being easy and fun to use. Have an ExperLogo experience. Ask you local Apple dealer for a demonstration today. **Circle 56 on reader service card**



ExperTelligence™
559 San Ysidro Rd.
Santa Barbara, CA 93108
(805) 969-7874

Macintosh is a trademark licensed to Apple Computer, Inc.

FastFinder™ = Fast Mac.

Essential software for anyone who wants to run a hard disk with a Mac FAST.

Quickies You define your own QUICKIE menu, listing your most-used command sequences. Convenient!	Process Search Scan and Count Combine Compare Display Source (TYPE) Display Data (DUMP) Display Resources (DUMPR) Create Source Listing	Show All (DIR) Some (DIR <wildcard>) Applications (APPL) Sources (TEXT) Documents (DOCS) Pictures (PICS) Disks (VOLS) Information About... (INFO) Current Date and Time (DATE)	Transfer Transfer to... Print file... (PRINT)
Utility Erase Rename Read Script Lock Unlock <input checked="" type="checkbox"/> Terse <input checked="" type="checkbox"/> Verbose <input checked="" type="checkbox"/> Novice Expert Set File Attributes (SETATTR) Set Startup (STARTUP)	Copy Whole File (COPY) Data Only (COPYD) Resources Only (COPYR) Console Input to a file (RECORD)		

FastFinder makes Mac faster, more useful, and more productive. Benefit: less waiting, easier disk and file handling by far!

FastFinder also makes Mac a professional development environment. Benefit: faster on-Mac programming using the Consulair Mac C™ Compiler, Mac C Toolkit, and the Apple 68000 Development System, and more.

• Eliminates time spent between programs. • 5 times faster than Apple's Finder! • More functions available, including key utilities, without leaving the finder! • Takes less disk space. • Handle up to 12 volumes at once. Network users note! • No LIMIT to NUMBER of FILES! (except physical directory space) • Boots almost instantly, even with large disk directories. Essential for Mac hard disk users! • Command equivalents for all pop-down menu choices. Pick the fastest way to execute. • Completely compatible. • Very fast. • Shipping since November, 1984. • Available NOW!

Order now and save!

Save time with a faster finder.
Save money.

\$100. Will be \$150.
(408) 372-1722

Immediate delivery. Tardis Software
(Because there is always a better way.)

See us at MACWORLD EXPO.

FastFinder: Tardis Software /Mac C: Consulair

Circle 187 on reader service card

Games investors play

"...The games can be as logical, yet as arbitrary, as markets themselves. They are certainly not child's play."

FORBES, July 16, 1984

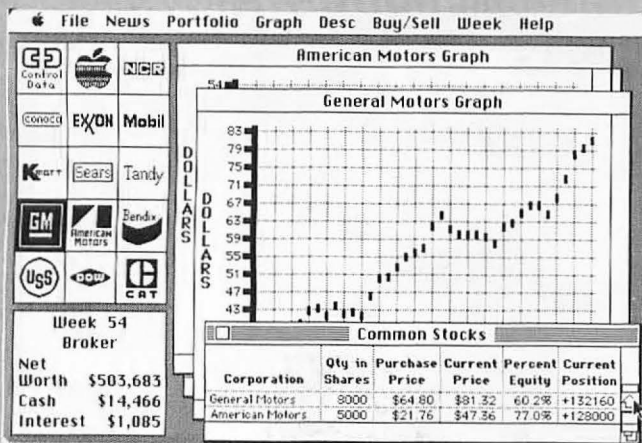

Interface Age magazine calls Millionaire, "the best stock market simulation we have ever seen." Millionaire teaches you essential stock market concepts, terms, and strategies based on actual stock market trends.

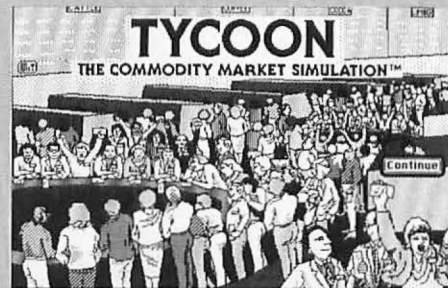
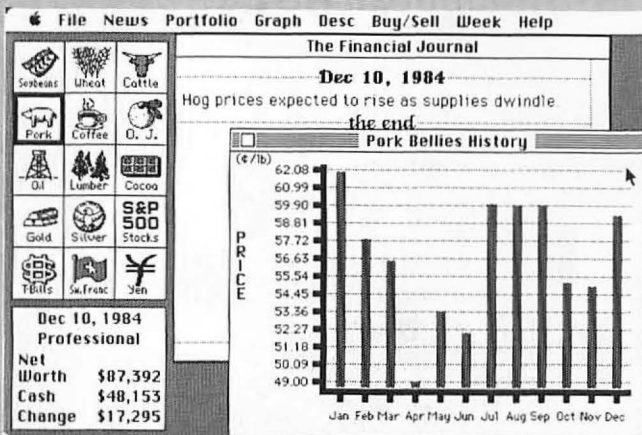

Tycoon lets you experience the high adventure of the volatile commodities market without putting your own money into it. Learn how to invest in agricultural commodities, precious metals, foreign currency, and more.

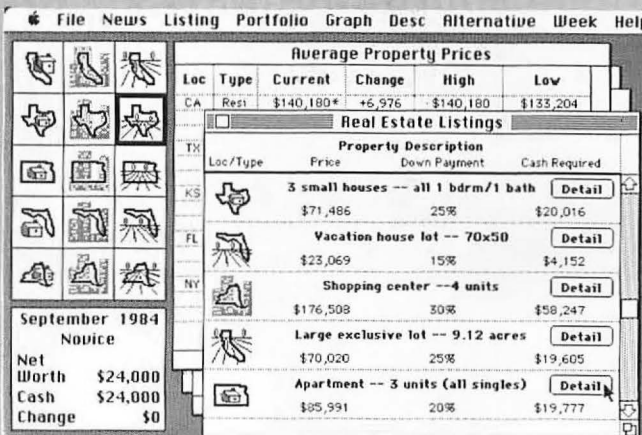

The factors to consider in real estate speculation — whether in Baron or in real life — are mind-boggling in their complexity: everything from fluctuating mortgage rates influenced by national and international events to neighborhood vandalism to your property.

The action is simulated. The excitement is real! Available from computer stores, software stores, and bookstores everywhere.

BLUE CHIP SOFTWARE
6744 Eton Avenue
Canoga Park, CA 91303
(818) 346-0730

Circle 138 on reader service card

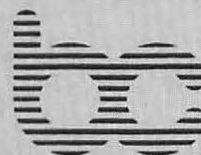

BLUE CHIP SOFTWARE

CURTIS

THIS DIAMOND IS FOREVER

Available at all ComputerLands, Entre Computer Centers, Inacomp, Micro Age, Eczel, or your local microcomputer dealer. Over 1000 locations nationally! In Canada: Micro-Computer Products, P.O. Box 235, Ajax, ONT, Canada L1S 3C3, (416) 427-6612.

For the location nearest you, call Curtis at (603) 924-7803.

Curtis Manufacturing Co. Inc.
305 Union Street
Peterborough, N.H.
03458

Curtis Electronic Surge Protection costs less and is warranted for a lifetime of protection, which should make you and your computer very happy.

With our Diamond's advanced circuitry and semiconductor technology, we promise to honor the laws of electricity.

To protect your computer hardware and software from dangerous overvoltage "surges, spikes and glitches" that can create disk read/write errors, destroy data and create instant hardware failure or drastically shorten system life, Diamond's color also blends perfectly with any modern office or home environment. If the Diamond is just not your type, come over some time and meet our other precious jewels — Ruby, Emerald, and Sapphire.



Diamond SP-1

Switched surge protector; adapts duplex outlet; six outlets.

- SPECIFICATIONS:**
- 6 Outlets, 15 Amps Total • 125 Volts, 1875 Watts • Operating Temperature 40°C to +85°C • Peak Pulse Power Dissipation @ 25°C, 585,000W for 8/20 Micro Sec. • Maximum Clamping Voltage @ Test Current 50A (8/20 sec.) 340V
 - Clamping Occurs Line to Line (normal mode) and Line to Ground (common mode) • Clamping Response Time: 1 Nanoseconds (1 × 10⁻⁹ sec.)
 - Dielectric Test: 3000VAC 60 Sec. • Forward Surge Rating @ 25°C, 1440 Amps For 1/120 Sec.

\$49.95

EMERALD SP-2

Switched surge protector; plugs into duplex outlet; 6 ft. power cord with built-in circuit breaker/switch; six outlets.

\$59.95



SAPPHIRE SPF-1

Switched surge protector; EMI-RFI filtered; adapts duplex outlet; three outlets.

\$79.95



RUBY SPF-2

Switched surge protector; EMI-RFI filtered; plugs into duplex outlet; 6 ft. power cord with built-in circuit breaker/switch; six outlets.

\$89.95



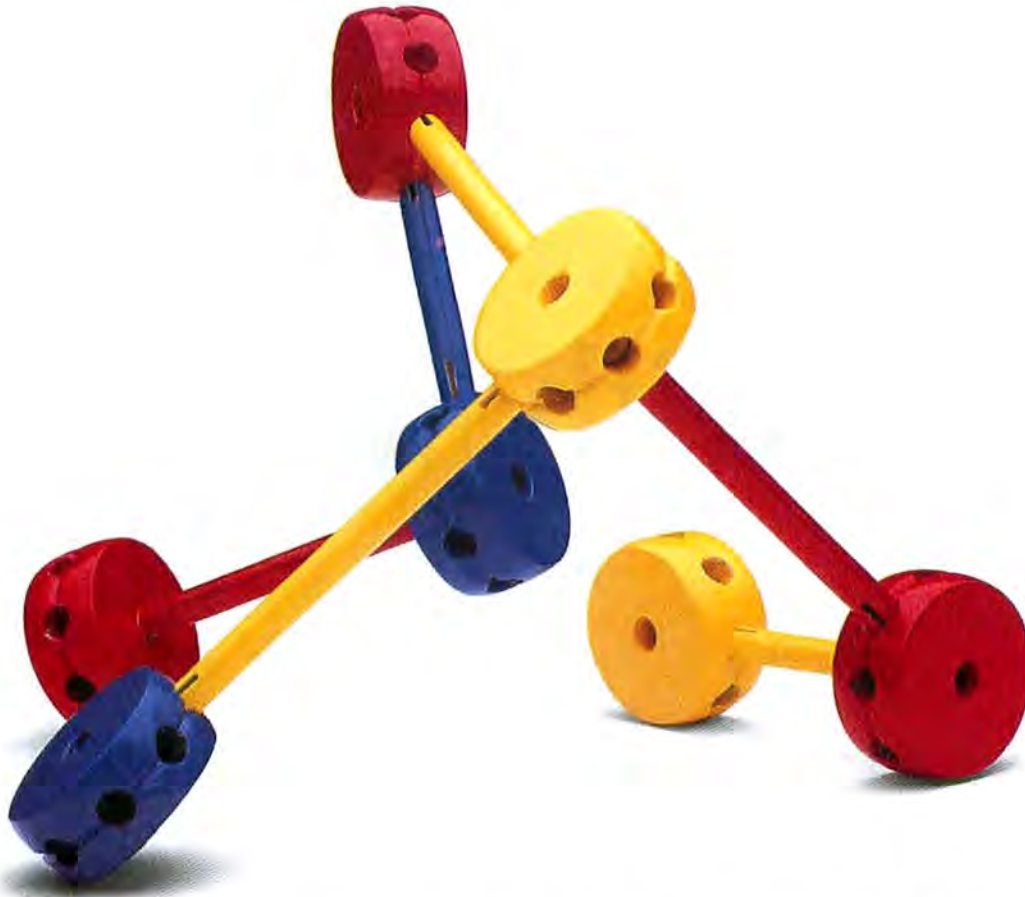

Networking Software So Simple To Use, It's Child's Play.

What do you think of when someone says "network"? Hardware? Complexity? Money? At TouchStone, we think networks should be simple.

The Connectables Software from TouchStone

The Connectables software — PCworks™, MacLine™, and UniHost™ — lets you build a network out of a collection of computers. Without special hardware, unnecessary complexity, or a lot of money.

UNIX+PC+Macintosh

Three great computers with different processors, different operating systems, and different data formats. The Connectables software lets you connect these systems together in whatever way you'd like to use them. Share electronic mail, exchange all types of files, run a program on another system, or use a remote com-

puter's disk or printer. The only hardware you'll need is a standard cable or telephone line and a serial data channel.

It's So Easy.

The Connectables software will take care of all the details — dial the right numbers, ask you what you want to do, and figure out the rest. Move a spreadsheet from your PC to a UNIX™ system, or transfer a text file from the UNIX system to your



THE CONNECTABLES™:
FAMILY OF COMMUNICATION SOFTWARE PACKAGES.

Macintosh™ for editing. Print the file later on either system, or use another computer to backup your data. With The Connectables software, things that should be easy to do, are easy to do.

Yesterday, Today, Tomorrow?

Making computers work together shouldn't be a problem. TouchStone's PCworks, UniHost, and MacLine software packages are only the first three members of The Connectables family. TouchStone is committed to the continued development of software products that solve compatibility problems. Even the problems we won't know about until tomorrow.

TouchStone

Software Corporation

909 Electric Avenue, Suite 207, Seal Beach,
California 90740, 213/598-7746

Now that you've test driven a Mac

Floor it with MacLion

If MacLion
can't tame
your database,
we'll give you
your money back.

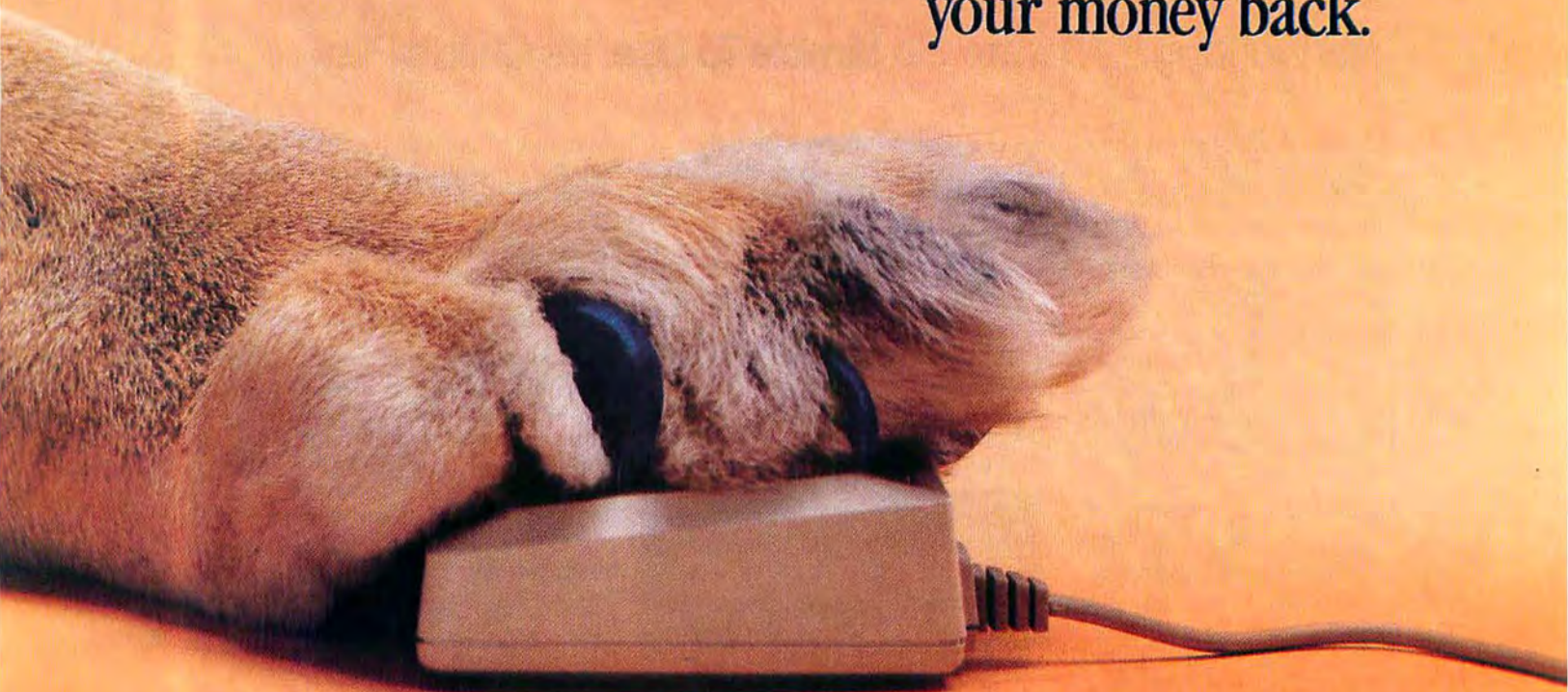

A Relational Database Management System

"We've developed more than 600 applications and we've never found a problem MacLion's programming language couldn't handle."

Glenn Slocum
Davis, Santo, and Associates

Out there in the great database jungle, only MacLion has the power to generate business programs to your specifications, on your Mac.

MacLion.

It alone has the power to deliver what it promises.

That's because MacLion's very own easy-to-use development language is structured to create multiple relational applications.

One example. With MacLion's screen generator, you can write an order entry system in a single day. With multiple relation access for both inputting and retrieving data.

Build an entire invoicing system in a morning using MacLion's report generator. And do it easily with data from multiple relations.

One final for instance. MacLion's data dictionary lets you change 5-digit ZIP codes to 9-digit codes in ALL files, with one simple instruction. Automatically, without any loss of data.

On top of that, MacLion takes full advantage of the mouse, pulldown menus, icons, help, dialogue boxes, etc. in helping you to create databases.

All of which is why we can be forgiven for claiming MacLion is King of the database jungle.

Compare MacLion with the competition and you'll see that its price tag of only \$379 is a steal.

If MacLion fails to live up to either our claims or your expectations, simply return it within 30 days to the place of purchase for a full refund.

For more information, please call our toll-free number 1 (800) 252-LION or (714) 634-9012.

MacLion runs on a 128k Macintosh and 2 disk drives. It runs faster on a 512k Macintosh, one disk drive and one hard disk.



1904 Wright Circle, Anaheim, California 92806

Macintosh is a registered trademark of Apple Computer, Inc.
MacLion is a trademark of Computer Software Design, Inc.

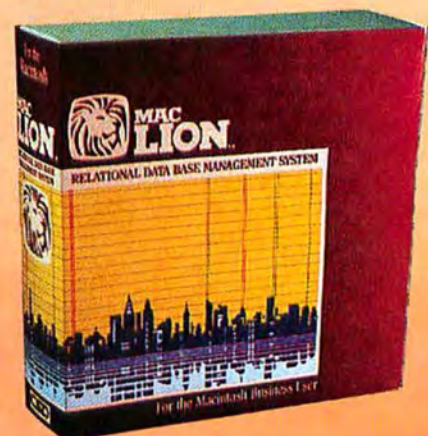

Circle 66 on reader service card

The Laser's Edge

Danny Goodman

On the desk, connected to a Macintosh, sat a machine the size of a small microwave oven. It looked like a photocopier without a hatch for original documents. The quiet rush of an internal cooling fan was about the only sound it made. Despite the absence of noise, the machine appeared to be hard at work; 8½- by 11-inch pages emerged every 8 to 30 seconds. To my astonishment, the printed sheets looked like professionally typeset *MacWrite* documents and artist-drawn *MacDraw* pictures—the kind of quality work that normally takes many hours to prepare. Although the printouts seemed magical, the machine was real—Apple's new LaserWriter laser printer.

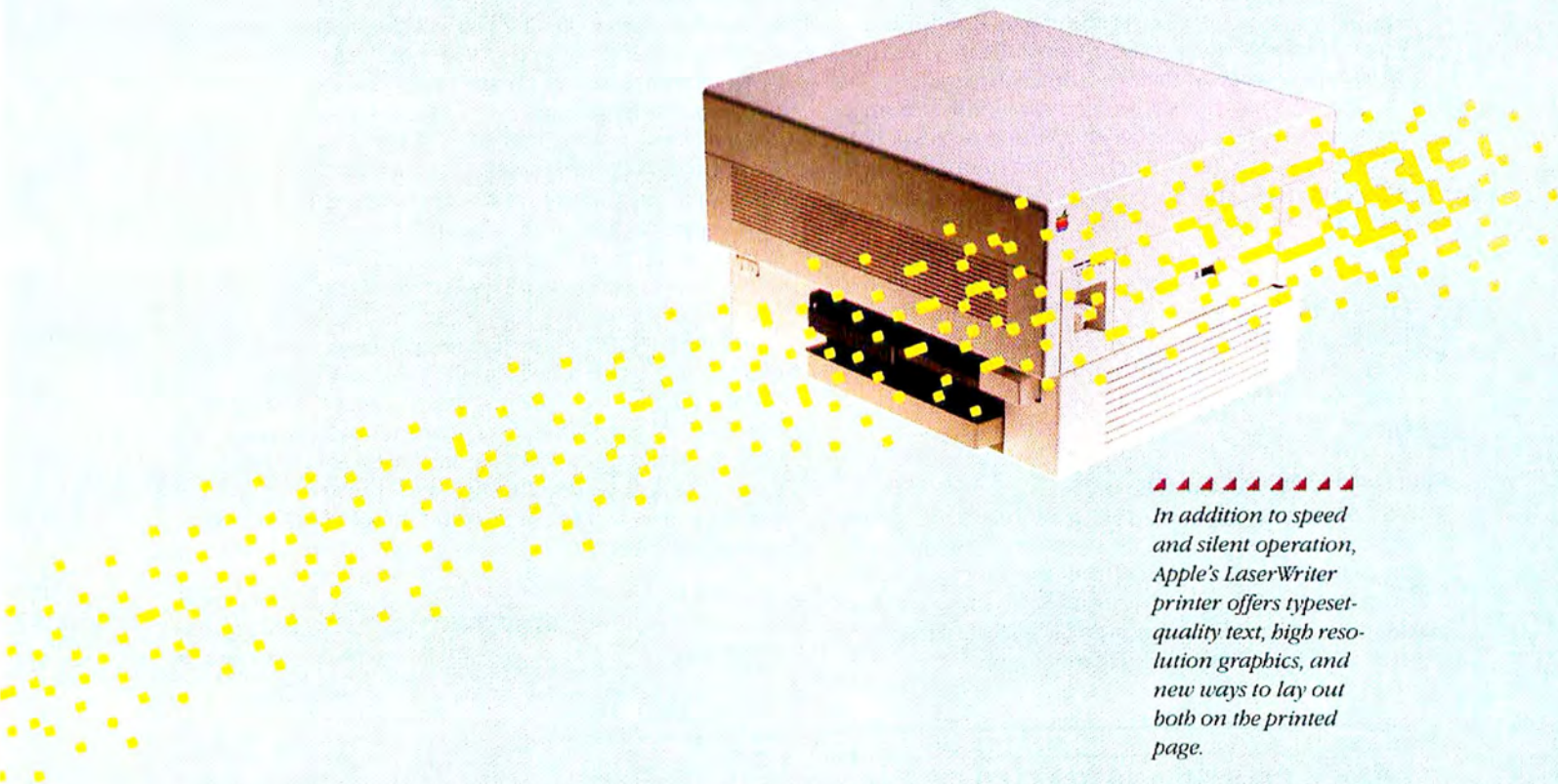

▲▲▲▲▲▲▲▲▲▲
In addition to speed and silent operation, Apple's LaserWriter printer offers typeset-quality text, high resolution graphics, and new ways to lay out both on the printed page.

Just as the Macintosh redefined the limits of personal computers, the LaserWriter redefines the limits of printers. Laser printers have been available since the mid-1970s, but until 1984 they were too expensive for most personal computer owners. The Xerox 9700, for example, costs \$400,000. Last year, Hewlett-Packard introduced the LaserJet for \$3495.

But to classify the LaserWriter with ordinary laser printers such as the HP LaserJet is like calling the Palace of Versailles a country house with a few pictures on the walls.

The LaserWriter has the usual features of laser printers—speed, silent operation, and high-resolution printing—but it also offers professional typefaces, full-page high-resolution graphics, and new ways to lay out text and graphics on the printed page. But these advanced features don't come cheap; at \$6995 the LaserWriter costs twice as much as the HP LaserJet.

The LaserWriter's advanced capabilities promise to change the way business people and professionals produce printed information. Documents look like those previously produced at considerable expense by skilled typesetters and graphic artists. The LaserWriter can print documentation, technical drawings, camera-ready art, and illustrations for written reports and oral presentations (see Figure 1). It can print directly on overhead transparency material. The printer can produce tax and insurance forms and newsletters that look like they came from a professional printer (see Figure 2).

The Print Engine

Although the LaserWriter is more advanced than other laser printers, it shares the same basic printing mechanism. Designers often call this mechanism the print engine. The LaserWriter uses the same semiconductor laser printing technique as do other laser printers that use the Canon print engine.

The Canon print engine forms character and graphics images by shooting a pinpoint stream of light pulses onto the surface of a large rotating drum (see Figure 3). Wherever a light pulse strikes, that tiny part of the drum takes on an electrical charge that attracts very fine toner powder as the drum rotates past the powder compartment. As the drum continues to rotate, it meets blank paper, letterhead stationery, transparency film, or a mailing label. When contact is made, a combination of heat and pressure fuses the "dots" of toner onto the paper or film to reproduce the image. The laser stream is so precise and the resulting dots so small that the print resolution is 300 dots per inch horizontally and vertically (which totals 90,000 dots per square inch).

To appreciate a laser printer's ability to produce high-quality print, it helps to understand the way a printer's resolution is measured. In general, resolution is defined in terms of dots or lines per inch, which represents the fineness of the grid used to construct the letters. The coarsest example of printer resolution is a dot matrix printer such as the Imagewriter, which typically prints type at 80 dots per inch. In the Mac's

THE WATERMILL News
The Monthly Newsletter of THE WATERMILL Restaurants, Inc.

FEBRUARY 12, 1985 VOLUME XIII NUMBER 45

Grand Opening of New WATERMILL in Rolling Hills, West Virginia
Rolling Hills, West Virginia will soon be the proud host to a new WATERMILL Restaurant, opening in March. A print ad campaign, offering a free coupon good for one glass of wine or a slice of our famous Chocolate Toffee Pie, will run for two weeks in local newspapers prior to the opening.

Take a valentine to lunch or dinner!

Welcome to our new look!
After market testing in 35 WATERMILL sites across the country, the new WATERMILL Restaurant logo (see above) was unanimously approved yesterday by the Board of Directors. It will be implemented next quarter. Watch your mail for phase-out requirements and start planning your inventory levels now. Kudos to Kristee Kreiman of our design staff for the snappy new look!

Sign up now for Spring courses in pastry making
Recent customer surveys confirmed our guess that demand for delicate French dessert pastries is increasing by leaps and bounds. In response to the demand, French chef Jean-Pierre Dubonnet will be teaching pastry courses in the regional sites during the month of April. All master chefs are encouraged to attend. Registration forms are available from Personnel.

35 New Managers Complete WATERMILL Training Course
Corporate Training Division is pleased to announce the arrival of 35 new managers for the East Coast region. The sixteen men and nineteen women, ranging in age from 25 to 38, completed their coursework at Corporate Headquarters with flying colors—the best scores overall for an incoming class in the company's history. Please welcome them aboard! They will be honored with diplomas and full fanfare at the annual Spring Banquet.

Special Wine Discounts Now Available
After successful contract negotiations last month with Sutter Home, Stag's Leap, and Trefethen, a new per case discount with those California wineries will go into effect May 1, 1985. Wine stewards should look for a special March mailing outlining the wines included in the discount program.

THE WATERMILL Restaurants—Now Celebrating 25 Years of Fine Dining
(See feature article, page 3)

Published monthly by THE WATERMILL Publishing Group, Cambridge, MA 02142. Story ideas and letters should be submitted to Lynnea Johnson and Elizabeth Yerra, Managing Editors, THE WATERMILL Publishing Group, P.O. Box 269, Cambridge, MA 02142.

Figure 1
This newsletter demonstrates the LaserWriter's ability to print high-resolution text and graphics, including documentation, technical drawings, camera-ready art, and illustrations.

STATECO ADMINISTRATIVE SERVICES
MEMBER CLAIM FORM

INSTRUCTIONS
1. Complete one Member Claim Form for each patient.
2. Attach an itemized bill containing patient's name, provider of service's IRS # name and address, type date and amount charged for each supply or service for each member claim.

MAIL THIS FORM WHEN COMPLETED TO
Stateco Administrative Services
P.O. Box 28367
San Jose, Ca. 95159
Attn: Claims Dept.

PATIENT'S NAME: LAST FIRST MIDDLE Date of Birth: Mo Day Yr SEX: MALE FEMALE RELATIONSHIP TO EMPLOYEE: SELF SPOUSE CHILD OTHER
OCCUPATION: EMPLOYER: (HOSP) PART A (MED) PART B
COVERED BY MEDICARE? YES NO IF YES, EFFECTIVE DATE: Mo Day Yr

GROUP NO. COVERAGE CODE AREA CODE PHONE NUMBER PROVIDER NAME: Physician, Laboratory, Pharmacy, Clinic, etc.
EMPLOYEE SOCIAL SECURITY NUMBER ADDRESS: CITY STATE ZIP
EMPLOYEE NAME: LAST FIRST MIDDLE DATE OF 1ST SERVICE: Mo Day Yr
GITY STATE ZIP NAME OF EMPLOYER

ILLNESS ACCIDENT WORK RELATED PREGNANCY RELATED
 YES NO YES NO YES NO YES NO
KIND OF ILLNESS DATE OF ONSET: Mo Day Yr
DATE OF ACCIDENT HOW ACCIDENT OCCURRED: Mo Day Yr
WHAT INJURIES WERE SUSTAINED: _____

DOES PATIENT HAVE OTHER HEALTH INSURANCE? YES NO
POLICY HOLDER'S NAME: LAST FIRST MIDDLE POLICY NUMBER
INSURANCE COMPANY NAME STREET CITY STATE

I CERTIFY THAT THE INFORMATION ON THIS CLAIM FORM IS TRUE AND CORRECT TO THE BEST OF MY KNOWLEDGE. I AUTHORIZE THE RELEASE OF ANY MEDICAL INFORMATION NECESSARY TO PROCESS THIS CLAIM FOR THE DURATION MARKED ABOVE.
MEMBER'S SIGNATURE (PARENT'S SIGNATURE IF PATIENT IS A MINOR) Mo Day Yr

So that Stateco can promptly review your claim for benefits, please review the form and the instructions to insure it has been completed correctly.

Figure 2
One useful application of the printer's capabilities is the production of forms. Using MacDraw or forthcoming software specifically designed for page layout, forms can be designed on the Mac and printed on the LaserWriter.

case, this resolution represents a close correspondence between the pixels on the screen and the dots on the printed output. This level of resolution creates readable type, but it can't produce the highly defined characters associated with letter quality printers.

The LaserWriter defines characters using a grid of 300 dots per inch, which is suitable for in-house memos, reports, and documentation but remains too coarse for high-quality printing jobs such as magazines and books. The type that you read in *Macworld* is resolved at 1950 dots per inch, and some typesetting systems can build type using a grid of over 5000 dots per inch.

In addition to being able to produce relatively high-resolution output, laser printers are quiet and fast. They are quiet because, unlike dot matrix and letter quality printers, they don't print with the impact of a print mechanism against paper. The LaserWriter can print letter quality text at up to eight pages per minute, or 300 characters per second (cps). By comparison, fast daisy wheel printers produce about 80 cps. The Imagewriter dot matrix printer prints standard-quality characters at 90 cps and draft-quality characters at 120 cps. A few dot matrix printers print at 300 cps, but they produce very coarse characters at that speed.

A Two-Megabyte Computer

The feature that separates the LaserWriter from other laser printers is the complete, special-purpose computer inside—a computer that in many ways is more powerful than the Macintosh itself. The LaserWriter's computer uses a Motorola 68000 microprocessor, the same one used in the Mac. The printer also has an enormous amount of memory—1.5 megabytes of RAM. This amount is almost 3 times that found in the 512K Mac and about 20 times the memory of the HP LaserJet. The advantage of so much memory is that the printer can image (translate a document into print

commands) an entire page in memory at once to produce full-page graphics in high resolution. By comparison, the HP LaserJet can print only 5½ square inches of high-resolution graphics at 300 dots per inch. The LaserJet can also produce full-page graphics, but at only 75 dots per inch. Another advantage of a large amount of memory is that the printer will never outpace the imaging process, an occurrence that can cause the printer to stall and produce blank pages.

Accompanying the LaserWriter's massive amount of RAM are 500K of ROM. If you add RAM and ROM together, the LaserWriter's total memory is 2 megabytes. The real magic of the LaserWriter lies in its ROM, which contains a library of type fonts and a program-

(continues on page 75)

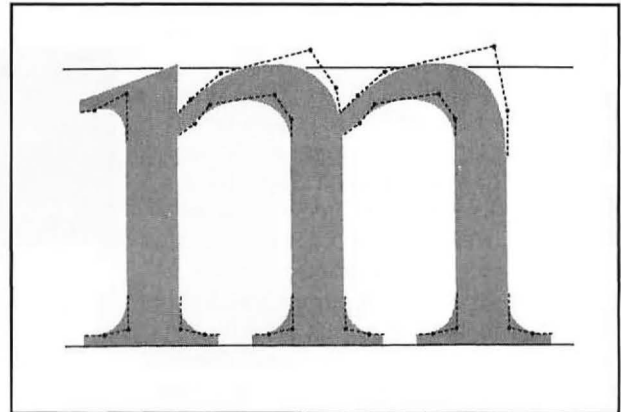

Figure 4
The LaserWriter's ROM contains outlines of a full set of characters in 13 font styles. Based on the outlines, the computer inside the printer can generate dot patterns for a character in any size.

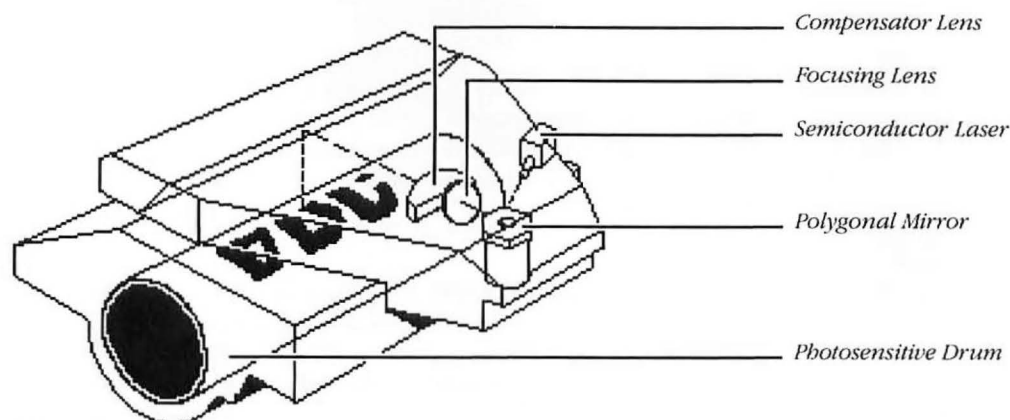

Figure 3

The LaserWriter creates images by shooting a pinpoint stream of light pulses from a laser beam through a system of mirrors and lenses onto the surface of a large rotating drum. Whenever a light pulse strikes the drum, a small electric charge is created that attracts very fine toner powder as the drum rotates past the powder compartment. As the drum continues to rotate, the toner is fused to paper by a combination of heat and pressure.

The AppleTalk Connection

The LaserWriter can be attached to a single Macintosh, but because its price is high, the printer will more likely be shared among a number of Macs in a network. The LaserWriter attaches to Apple Computer's AppleTalk network, previously referred to as the AppleBus (see the figure "Attaching the LaserWriter"). AppleTalk serves as an electronic "highway" linking one or more Macs to a LaserWriter or other devices in a network.

The LaserWriter, the Macintosh, and future products planned for the network each have specialized chips that enable devices to communicate over the network. Up to 32 devices (Macs, printers, or file servers for program and documentation storage) can be connected to the network. The only hardware required to link the devices is a cable that costs \$50 per device.

Electronic mail software is being developed to enable people to send messages and documents between Macs on the network.

Since AppleTalk can transfer information no faster than 231 kilobits (29 kilobytes) per second, the 1 megabyte of information required to image a printed page would normally take a long time to arrive at the printer. Because the LaserWriter contains a built-in computer, printing a document is faster than if all the processing were handled by the Mac alone. When you print a *MacWrite* document, for example, the LaserWriter Print Manager goes to work after you select the Print option from the File

menu. The Print Manager converts the document from QuickDraw commands into PostScript commands, which are then sent to the LaserWriter for processing in its own computer.

If the Mac were doing page assembly within its own memory instead of leaving it for the LaserWriter's built-in computer, the Mac would have to shuttle

printer requires only 4 to 8K. This amount of data is 100 to 200 times less than 1 megabyte, and can be sent over AppleTalk in less than 1 second.

The printing commands sent from the Mac via AppleTalk to the LaserWriter are standard ASCII characters—the same signals transmitted over a modem. Any computer capable of gen-

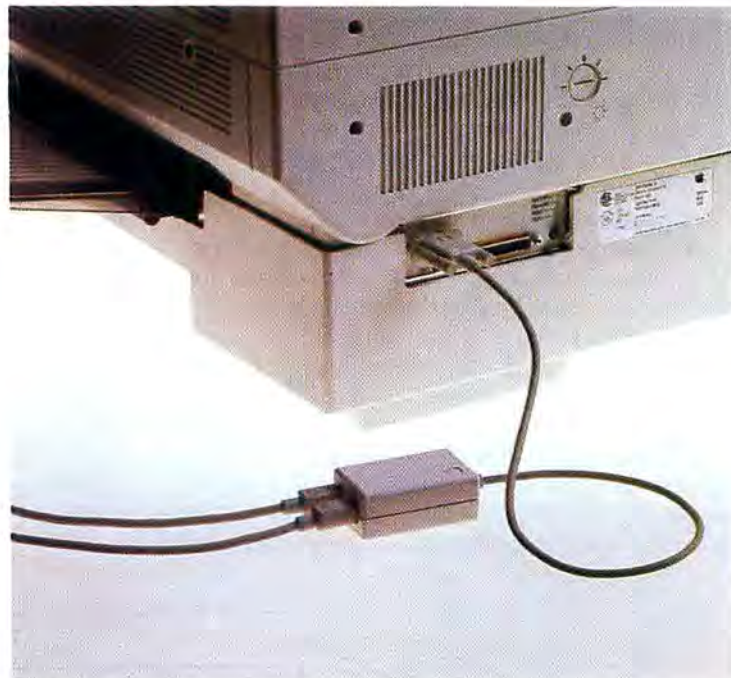

Attaching the LaserWriter

The LaserWriter is attached to one or more Macintoshes via the AppleTalk network. Each device in the network needs an AppleTalk connector set.

approximately 1 megabyte of printer information to the printer via AppleTalk. At AppleTalk's 29K per second maximum speed, it would take over 30 seconds to send a page of information to the printer. But because the Print Manager converts the page data into PostScript inside the Mac, letting the LaserWriter's computer do page assembly, the information to be transferred to the

erating PostScript commands can use the LaserWriter by communicating information via the printer's serial port. If you are proficient in the PostScript language, you can use a dumb terminal, instead of a computer, to send PostScript commands to the printer to create both text and graphics.

(continued from page 73)

ming language created specifically for high-resolution laser printers. These features give the Mac (with the assistance of specially designed software) the flexibility to produce printed text and graphics in any size or angle of rotation.

PostScript

The LaserWriter's language, called PostScript, converts simple commands from an external computer, such as the Macintosh, into precise images of text characters and graphics that are then painted on the print engine drum with the laser (see "The Language that Talks to Your Printer" in this issue for an explanation of PostScript).

Of particular interest is the way PostScript generates text characters inside the printer. Unlike other multiple-font laser printers, which generate text characters from a stored table of "bit maps" for each character in a given size, the LaserWriter stores the outlines of characters in 13 font styles (see Figure 4). The uniqueness of this text-generating system is that the outline of a font has to be stored in only one size in ROM. The computer inside the printer generates dot patterns (bit maps) for each character in virtually any size decreed by the software that you are running.

The fonts contained within the LaserWriter's ROM are designed to produce the highest-quality type that the laser printer is capable of printing (see "A Face for All Seasons" in this issue for a look at the laser fonts). Additional fonts are currently being designed for the LaserWriter; you will be able to download them into the printer's RAM from a floppy disk.



Figure 5

Disposable snap-in cartridges contain the toner and other parts of a laser printer that are the most likely to degrade print quality over time. Each cartridge should be good for 2000 to 3000 copies and costs about \$99.

Setup Procedures

To set up the printer you must add two AppleTalk connectors: one for the Mac and another for the printer (see "The AppleTalk Connection"). If more than one Mac is using a LaserWriter—which is a cost-effective way to use Macs and the LaserWriter in an office environment—you need one AppleTalk connector for each Mac.

The LaserWriter does not come with a toner cartridge; you will have to purchase one from an Apple dealer to get started. To improve reliability and reduce the need for service, the toner and other parts of a laser printer that are the most likely to degrade the print quality over time come in disposable cartridges that anyone can snap in (see Figure 5). The cartridges should be good for 2000 to 3000 copies, depending on how much toner your pages require. Graphics pages that have heavy borders and many dark areas, for ex-

(continues on page 77)

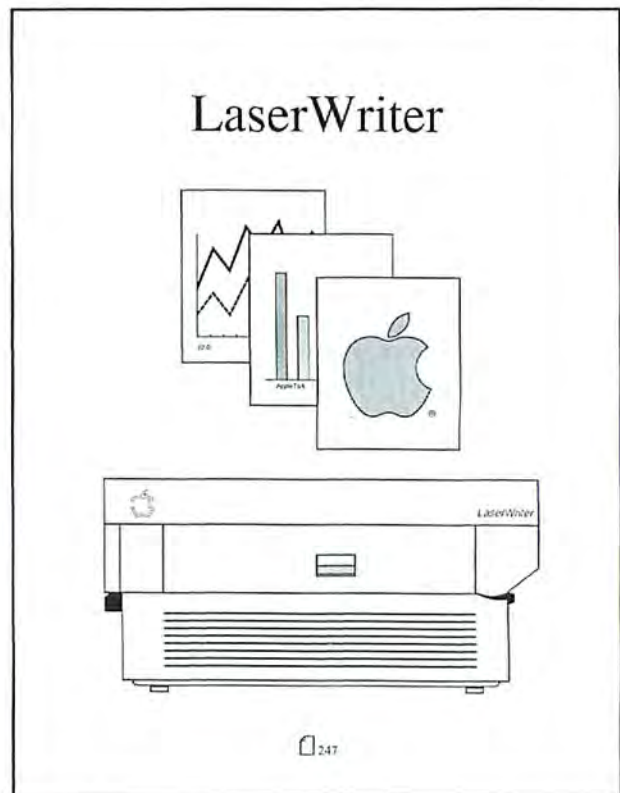

Figure 6

Each time you turn on the LaserWriter, it prints a diagnostic sheet that contains coded information on its current state. Next to the page icon on the bottom of the sheet is the number of copies printed since the very first time the printer was used. The bar and line graphs show current port and switch settings.

Anatomy of a Printing Job

Perhaps the best way to understand how the Macintosh and the LaserWriter work together is to follow the execution of a small printing job from beginning to end. The document is a three-page *MacWrite* report. The text is written almost entirely in Times Roman-12, but the headline and several sub-heads are in larger sizes and in boldface. As you type the document, you select the appropriate fonts from *MacWrite*'s Font menu, just as you would select Seattle or Monaco for the Imagewriter.

When you are ready to print a document, choose Print from the File menu and select the printing parameters in the dialog box that appears. After you click the OK button in the Print dialog box, the Mac and the LaserWriter begin communicating with each other. The Print Manager converts the document's print file from QuickDraw commands into PostScript commands and sends the commands to the LaserWriter. Then either a dialog box indicates that the printer is ready to print your document, or a screen message advises you that the LaserWriter is working on another document.

With several people sharing the printer, printing bottlenecks are likely to occur, forcing people to wait. Print spooling software, which is unavailable at the time of this writing, should solve the bottleneck problem. A spooler would temporarily store the documents sent to the printer and then print them when the printer was free. Product managers at Apple say that print spooler software will become available later in 1985.

During printing the Mac sends PostScript commands to the LaserWriter one page at a time. Inside the LaserWriter the PostScript computer converts the incoming commands to "dot information." In the case of text characters in the document, the first ones encountered are Times Roman Bold-18, the headline of the first page. The computer inside the printer retrieves character outlines from ROM and assembles a bit map for each character in 18-point. This bit map models in memory the placement of dots that will appear on paper.

The bit-mapped characters in 18-point are stored in a small portion of the 1.5 megabytes of RAM. The characters remain in memory so that if they are needed later, they won't have to be assembled from the ROM font outlines. The character bit maps are also sent to a portion of RAM where the entire page is assembled bit by bit. This assembling process quickly fills up almost one full megabyte of the RAM for each page.

For the main portion of the text on the first page, the LaserWriter calls upon one of three fonts stored in ROM. Those fonts—Times Roman-12, Helvetica-12, and Courier-10—are the most frequently used fonts in business communications. By having these fonts already bit-mapped in ROM, the page can be assembled much faster than if the fonts had to be reconstructed for each printing job.

MacWrite text in fonts other than those stored in the LaserWriter don't print with the same sharp appearance as the laser fonts. Characters are smoothed to some degree and look better than those produced on the Imagewriter, but they don't have the high resolution and the resulting near-typeset quality of the laser fonts.

The first page of a printing job takes about 30 seconds to assemble and print. Succeeding pages are ejected at about 8 pages per minute. Although the LaserWriter is fast, its paper loading tray holds only 100 sheets of paper. If several people sharing a network use the printer in succession to print long documents, the paper tray will have to be refilled fairly often.

Printing graphics can take longer than printing text, because most graphics images are more complex. While previewing a LaserWriter prototype, I created an organizational chart with *MacDraw*. The printer took only slightly longer to print the chart than it took to print the first page of the *MacWrite* report mentioned earlier. However, a highly detailed graphics image that frequently varies the white and black dots in the picture takes longer to print than a simple chart.

The LaserWriter Print Manager is optimized for *MacDraw*-type graphics rather than *MacPaint* graphics. *MacDraw* stores the attributes of objects (the attributes of a square start at point x_1, y_1 and end at point x_2, y_2 , with a border of z thickness, filled with pattern w). *MacPaint* reduces objects to a series of picture elements (bits), as they appear on the screen. It is easier to convert the *MacDraw* attributes into PostScript commands than it is to convert the relatively coarse bit images from a *MacPaint* picture. A *MacDraw* circle, for example, prints on the LaserWriter with a smoother curve than the same object drawn in *MacPaint*.

Writing is dead in Europe; and even when it flourished, it was
Writing is dead in Europe; and even when it flourished, it was

ample, use more toner than pages of straight text. Canon estimates that the \$99 cost of the Apple cartridge is roughly equivalent to the replacement cost of ribbons and print wheels for a letter quality printer producing an equal number of pages.

After slipping the toner cartridge under the hood of the printer, you can turn on the LaserWriter. The printer goes through an internal self-test and produces a printout (see Figure 6). This sheet—which prints each time you turn on the printer—may seem superfluous but contains coded information about the printer's current state, including the communications switch settings and the number of copies that have been made since the first time the printer was turned on. That number, printed at the bottom of the sheet, is stored inside the printer in a special circuit (EPROM) that retains information even after the printer is turned off or unplugged.

Software Installation

Once you set up the LaserWriter's hardware, you have to use an installation program from the LaserWriter disk, which comes with the printer, to modify your application disks so that they will work with the LaserWriter. When you open the installation program it adds new fonts to the System file and adds a LaserWriter file to the System folder. The LaserWriter file contains an AppleTalk driver and its own printer manager. The AppleTalk driver designates the printer and modem port for connecting the printer to the AppleTalk network.

Figure 7

When you install the LaserWriter software, the screen fonts representing the fonts contained in the LaserWriter's ROM are added to the System file. The names of the added fonts (Times, Symbol, Helvetica, and Courier) appear in the Font menu above the System fonts.

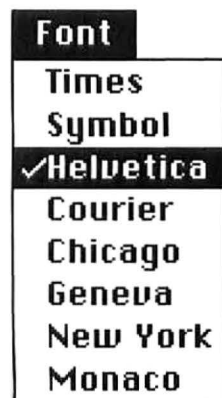

Figure 8

A comparison of text in 18-point Times Roman as printed by the LaserWriter (top line) and as it appears on the screen (bottom line).

The fonts included on the LaserWriter disk are "screen fonts." After the LaserWriter software is installed, the fonts appear in the Fonts menu along with the original Mac fonts (see Figure 7). These fonts should not be confused with the fonts residing in the LaserWriter. The screen fonts represent the built-in LaserWriter fonts on the Mac screen and don't contribute to print quality.

"Tuning" the fonts to make them both easy to read on the Mac screen and representative of the font style (see Figure 8) was a job comparable to building a dollhouse with stone blocks from the Pyramids. Compared to the LaserWriter's resolution of 90,000 dots per square inch, the Mac's screen displays only 5184 dots per square inch. Because the great difference in resolution could not always be overcome, some of the LaserWriter fonts look fuzzy on the Mac screen (see Figure 9). Smaller sizes, especially those under 12 points, suffer from the Mac's relatively low screen resolution.

With the LaserWriter, you lose the one-to-one correspondence between screen images and printed output that you usually get using the Mac and the ImageWriter, but you gain highly defined characters. A few font sizes retain a relatively close correspondence to the fonts you see on the screen. Of the font sizes available in *MacWrite*, only 9-, 12-, 18-, and 24-point fonts are tuned to look the same size on screen as when printed by the LaserWriter.

MAKE SHORT WORK OF LONG EQUATIONS

**Introducing TK!Solver[®] for Apple[®] Macintosh[™].
An equation processing program that helps students and
professionals solve even their most difficult problems.**

For those who own the personal computer that's so powerful and easy to use, here's a new productivity tool that makes solving problems easier than ever. TK!Solver for Apple Macintosh. The complete tool for the knowledge worker—whether you're an engineer, scientist, educator, financial analyst or student.

Let TK!Solver take on your toughest problems—even sets of simultaneous non-linear equations. No matter how you're used to solving problems, just enter the equations (unknown variables can appear anywhere) and the known values. And click. You have the solution quickly. Without programming.

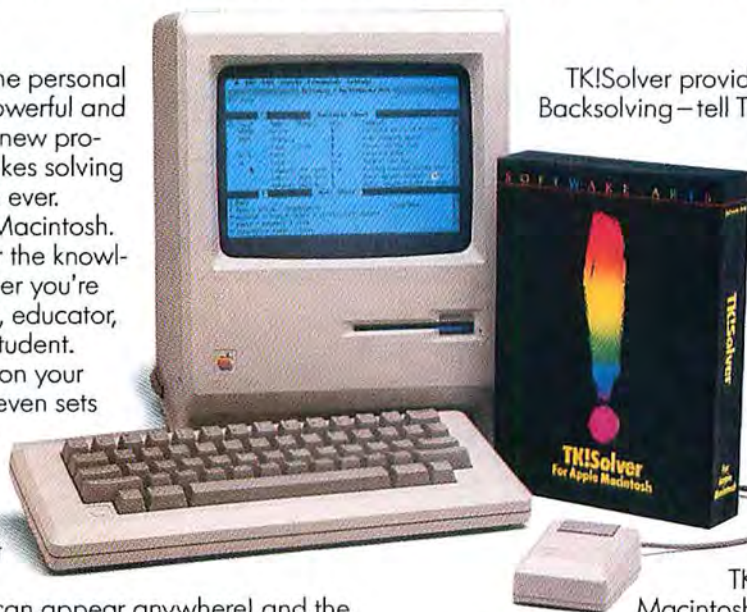

TK!Solver provides sophisticated features like Backsolving—tell TK! what you know, and it figures out the way to solve the problem. Iterative Solving—successfully attack even problems involving sets of simultaneous non-linear equations. Unit Conversions—for automatic conversions between different units of measurement. List Solving—solving a model repeatedly for lists of input values. Tables and High Resolution Plots—produce plots using symbols, lines or a combination of both.

TK!Solver takes full advantage of Macintosh's Cutting and Pasting, Pull-Down Menus, High Resolution Graphics, and also provides a friendly Help and Error Diagnosis System.

TK!Solver[®]
By Software Arts[™]

27 Mica Lane, Wellesley, Massachusetts 02181

Circle 79 on reader service card

Helvetica 10-point

ABCDEFGHIJKLMNOPQRSTUVWXYZ
abcdefghijklmnopqrstuvwxyz

Helvetica 12-point

ABCDEFGHIJKLMNOPQRSTUVWXYZ
abcdefghijklmnopqrstuvwxyz

Helvetica 18-point

ABCDEFGHIJKLMNOPQRSTUVWXYZ
abcdefghijklmnopqrstuvwxyz

Times Roman 10-point

ABCDEFGHIJKLMNOPQRSTUVWXYZ
abcdefghijklmnopqrstuvwxyz

Times Roman 12-point

ABCDEFGHIJKLMNOPQRSTUVWXYZ
abcdefghijklmnopqrstuvwxyz

Times Roman 18-point

ABCDEFGHIJKLMNOPQRSTUVWXYZ
abcdefghijklmnopqrstuvwxyz

Courier 10-point

ABCDEFGHIJKLMNOPQRSTUVWXYZ
abcdefghijklmnopqrstuvwxyz

Courier 12-point

ABCDEFGHIJKLMNOPQRSTUVWXYZ
abcdefghijklmnopqrstuvwxyz

Courier 18-point

ABCDEFGHIJKLMNOPQRSTUVWXYZ
abcdefghijklmnopqrstuvwxyz

In addition to the AppleTalk driver and the screen fonts, the LaserWriter disk contains the LaserWriter Print Manager. The Print Manager helps your application program convert the output from the Mac into the PostScript commands understood by the printer. By copying the Print Manager file to your application disks, you enable all Mac software to run with the LaserWriter without modification. If you don't plan to use the LaserWriter for all your printing jobs, and you want to send documents to another printer such as the Imagewriter or a daisy wheel printer, you can switch between printers with the help of a new desk accessory that is also included on the LaserWriter disk.

After using the LaserWriter for a while, it struck me that the printer represents a breakthrough that in some ways overshadows the innovations of the Macintosh itself. The LaserWriter makes me think less about the Mac's mouse, pull-down menus, and other elements that make the machine so different. The new printer makes me think of using the Mac to produce finely detailed, professional-looking business documents. The LaserWriter's high-quality printing may be the key that opens corporate doors to the Macintosh. □

▲▲▲▲▲▲▲▲▲▲ *Danny Goodman is a Contributing Editor of Macworld and the author of several personal computing books. He has appeared as a product reviewer on the Public Broadcasting System television series "The New Tech Times."*

▲▲▲▲▲▲▲▲▲▲
*LaserWriter
Apple Computer, Inc.
20525 Mariani Ave.
Cupertino, CA 95014
800/538-9696, 800/662-9238 in
California
List price: \$6995*

Figure 9
Designing screen fonts that are both easy to read and representative of the font style is a difficult job. Because of the great difference in resolution between LaserWriter printing and the Macintosh screen display, some LaserWriter fonts look fuzzy on the Mac screen.

Ready...

Keep those cards and letters coming.

The odd, original, and obscure are beginning to crawl out of the woodwork. Our suspicions were correct. Mac owners have some delightfully bizarre tales to tell.

We're beginning to get some response to our campaign to uncover deep dark original Mac secrets. But where are the rest of you?

Look, we know it's hard to talk about yourself sometimes. We know that you may be reluctant to tell the whole world what you and your Mac do when no one is looking. But believe us — it's easy. Just sit down at your keyboard and write: "you're not going to believe this but..." and the whole horrible truth and nothing but the truth will pour out. (We ought to know — that's how we write these ads.)

Or, ask your kids to help. They're always ready to add a slightly strange twist to your day. Like the time they tried using the cat as a surge protector. Or when they inadvertently ran up a \$200 phone bill on the modem.

And, while you're contemplating your future as a certifiably famous Mac person, take a look at this month's product list. Just flip the page on your right for our complete selection.

Ready, set, dial!

Wait a second. Before we can fulfill your order we have to satisfy every whim of our ravenous new mainframe. It needs to know such minor details as bill to, ship to, method of payment, method of shipment, and, of course, what you'd like to order. And we'd like to have you tell us what the small code number is that appears near our phone number on the ad you're looking at.

If you have all this information ready, we'll have you back to work (or play) and your new program/add-ons in the delivery trucks that much quicker.

SOFTWARE

ATI

MacCoach Training (*Interactive teaching program for using the Mac. Two disks/handbook.*)... \$49.

Ann Arbor Softworks

Animation Toolkit 1 (*Create, edit, and animate pictures right on your Mac.*)... 39.

Animation Toolkit 1 advanced version (*All the features above plus sound.*)... 54.

Apropos

You must have Multiplan to use.

Financial Planning (*Home budget, tax, auto, life insurance and college planner.*)... 65.

Investment Planning (*Stocks, real estate, loans, IRA vs. CD's.*)... 65.

Axlon

Art Portfolio (*120 drawings await your creative desires.*)... 44.

Card Shoppe (*Make professional quality greeting cards.*)... 44.

Creative Solutions

MacForth - Level 1 (*Learn to program your Mac in "Forth". Define your own menus & windows.*) 99.

MacForth - Level 2 (*Now you can get serious. Level 2 includes an assembler, floating point, and advanced graphics.*)... 139.

Desktop Software

1st Base (*File management and report writing program for use with MacWrite & MacPaint.*)... 109.

Dow Jones

Straight Talk (*Communications package for accessing on-line databases and other Macs and micros.*)... 54.

1st Byte

Smooth Talker (*Voice synthesis software for the Mac.*)... 119.

Haba Systems

Habadex (*Desktop management with address phone directory, appointments, travel expenses, phone dialer, database management, and mail-merge capabilities.*)... 78.

Harvard Associates

MacManager (*Improve your strategic business skills with this simulation.*)... 35.

Hayden Software

Hundreds of design images that can be put into Mac's scrapbook, adjusted with MacPaint, and used in your own drawings. For professionals and amateurs.

DaVinci Buildings... \$34.

DaVinci Interiors... 34.

DaVinci Landscapes... 34.

Hippopotamus Software

Hippo-C - Level I (*Edit, compile, link, and execute C programs on a 128k Mac.*)... 117.

Human Edge Software

The Sales Edge (*Helps prepare strategies for all aspects of sales negotiations.*)... 169.

The Communications Edge (*Identifies communications strengths and weaknesses.*)... 113.

The Management Edge (*Identify and evaluate management skills and discover methods for improvement.*)... 129.

The Negotiation Edge (*Develop "How To" plan by analyzing critical factors.*)... 179.

Mind Prober (*Software that reveals people's hidden thoughts.*)... 31.

Linguist's Software

MacGreek (*12 + 24 point Greek font including math symbols.*)... 89.

MacHebrew (*12 + 24 point Hebrew font. Text reads left to right.*)... 89.

MacKana/Basic Kanji (*12 point Japanese font. Includes approximately 70 of the most common Kanji.*)... 75.

MacGreek/Hebrew/Phonetics (*12 + 24 point includes all extra symbols of phonetic alphabet.*) 149.

Living Videotext

ThinkTank 128 (*Put your ideas into ThinkTank and let your thoughts flow. The perfect idea organizer.*)... 85.

Magnum

McPic - Volume I (*Create fancy memos, maps, logos, etc. with this collection of MacPaint drawings.*)... 35.

McPic - Volume II (*150 new pictures.*)... 35.

The Slide Show Magician (*For presentations, teaching or just plain fun.*)... 38.

Matrix Advocates

Images (*Ready to use graphics and pictures.*) 28.

Megahaus

Megafiler (*Instant access to all your data. Print reports in a variety of formats.*)... 139.

Megamerger (*A mailmerge for Macwrite — generates form letters and mailing labels.*)... 86.

Microsoft

Basic (*The standard micro language — now available for the Mac.*)... 99.

MacConnection™

MacConnection, 14 Mill Street, Marlow, NH 03456 603/446-7711

We'd like to think you're a little strange.

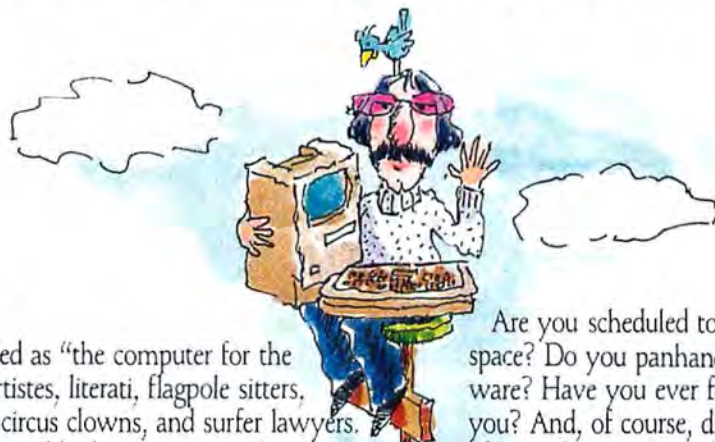

Why be normal?

The Mac was heralded as "the computer for the rest of us." For the artistes, literati, flagpole sitters, creative accountants, circus clowns, and surfer lawyers. For any otherwise-normal-looking person with a taste for the truly fascinating, off-beat, or plain old different.

Thanks to the Mac, you've probably experienced the wild-eyed frenzy of computer addiction. Or, you may have brought an illusion of order to your chaotic life.

But have you sold out? Are you normal? Ordinary? We sincerely hope not. We think that even the most straight-laced among you have a deep dark secret crying to get out. An experience that proves you are still certifiably intriguing. If not totally off the wall.

This is your life. (Or, Mac bites dog.)

Tell us your best Mac story. Are you powering your Mac with an ancient generator in the remote Canadian wilderness? Has your Mac ever saved your life? Did you canoe solo down the Amazon with only a Mac for company? Do you use your Mac to keep track of the plant locations on your ginseng farm?

Do you use your mouse as a hood ornament?



Are you scheduled to take the first Mac into space? Do you panhandle to raise money for software? Have you ever felt that your Mac was out to get you? And, of course, did you meet the woman/man/etc. of your dreams through your Mac? (Or, have you ever been caught fooling around with someone else's Mac?)

Get the idea? Send MacConnection your strange-but-true Mac story, along with any relevant snapshots, Mac drawings, and/or newspaper clippings. Be sure to enclose your name, address and telephone number. Don't forget to keep a copy for yourself—everything you send us becomes the property of MacConnection.

Do I win a prize?

But, of course. If we use your Mac story in one of our ads, you'll receive \$500 worth of add-ons and software—your choice. Plus, your name will be up in lights, and your winning smile will be gracing the pages of this magazine.

In the meantime, we're here to offer you the lowest prices, best advice, and strongest customer support available. And to help you fulfill your wildest Mac dreams.

MacConnection™

MacConnection, 14 Mill Street, Marlow, NH 03456 603/446-7711

Just the Facts

If you're overwhelmed by the facts of life, a new file management program might help you keep things in perspective

Bill Grout

On-the-job embarrassment often arises from a simple lack of organization. Your boss, for example, may request a few facts on a project you're managing. You know the answers are close at hand, on a note you scribbled to yourself only yesterday. As you feverishly search through the strata of notes on your desktop, your boss stands over you trying to look patient. When you realize the search is going to require serious excavation, you sheepishly tell your boss that you'll send up the information "momentarily."

Factfinder brings order out of desktop clutter without requiring you to drastically change your work habits. The program replaces a cluttered bulletin board, a desk drawer jammed with dog-eared memos, lists of hastily penned reminders, and boxes of file cards. You can still jot down notes and keep track of information in the casual way you're accustomed to. But don't confuse this program with data management systems that handle large business applications such as inventory, payroll, or accounts receivable. *Factfinder* trades the power to sort and search large amounts of structured data for the freedom to record information in an unstructured way.

Factfinder models its functions on the metaphor of a memo pad. You use memo pads for notes, phone numbers, and other impromptu information that you want to remember. Once you make a note, you tear off a sheet and put it in a pile with other notes to yourself. After a while the notes stack up, and you may have to paw through the stack to find a specific note. Like a memo pad, *Factfinder* lets you record information with a minimum of structure, but it also helps you find notes later when you need them. Like a magician snatching a card from thin air, *Factfinder* deftly pulls a note from a stack and displays it on screen.

Factsheets

Factfinder allows you to preserve your spontaneous style of taking notes by letting you record information on notepad-like screen windows called factsheets (see Figure 1). When a factsheet first appears, it takes up about half the Mac's screen. You can stretch or shrink a factsheet the same way that you resize other windows. You can also change the size of a factsheet by clicking the button in the factsheet's lower-left corner. The first click enlarges the factsheet so that it fills the entire screen. By clicking the button a second time, you return the factsheet to half-size. The factsheet window has a scroll bar so you can view notes from beginning to end.

After you move the pointer into the note space and click the window to make it active, you can type text to your heart's content. You type and edit text like you do in *MacWrite*. Text wraps automatically to fit the current window size so that the text doesn't disappear beyond the window's right edge. Notes can be as short as a few words or as long as three to four typewritten pages, depending upon the amount of available memory.

Leaving Clues

When you've finished typing a note, you leave clues to help you find the factsheets and the information they hold. You designate keywords that represent a factsheet's contents and use them to search for it. A budget meeting memo, for example, might be given keywords such as *memo*, *budget*, *meeting*, or a specific word used in the factsheet itself. You can assign as many keywords to the factsheet as you want.

We'd like to think you're a little strange.

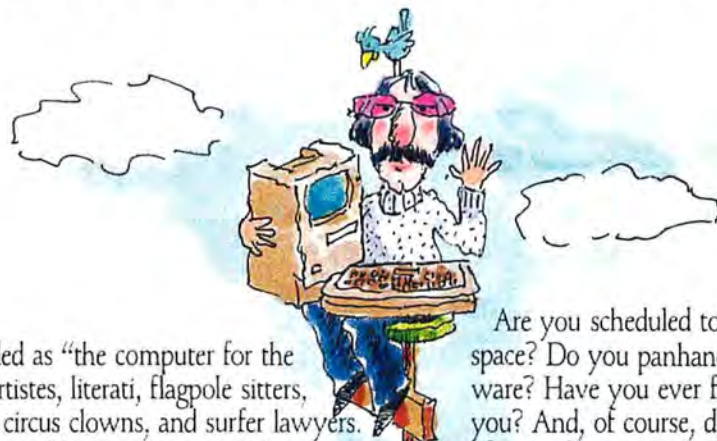

Why be normal?

The Mac was heralded as "the computer for the rest of us." For the artistes, literati, flagpole sitters, creative accountants, circus clowns, and surfer lawyers. For any otherwise-normal-looking person with a taste for the truly fascinating, off-beat, or plain old different.

Thanks to the Mac, you've probably experienced the wild-eyed frenzy of computer addiction. Or, you may have brought an illusion of order to your chaotic life.

But have you sold out? Are you normal? Ordinary? We sincerely hope not. We think that even the most straight-laced among you have a deep dark secret crying to get out. An experience that proves you are still certifiably intriguing. If not totally off the wall.

This is your life. (Or, Mac bites dog.)

Tell us your best Mac story. Are you powering your Mac with an ancient generator in the remote Canadian wilderness? Has your Mac ever saved your life? Did you canoe solo down the Amazon with only a Mac for company? Do you use your Mac to keep track of the plant locations on your ginseng farm?

Do you use your mouse as a hood ornament?



Are you scheduled to take the first Mac into space? Do you panhandle to raise money for software? Have you ever felt that your Mac was out to get you? And, of course, did you meet the woman/man/etc. of your dreams through your Mac? (Or, have you ever been caught fooling around with someone else's Mac?)

Get the idea? Send MacConnection your strange-but-true Mac story, along with any relevant snapshots, Mac drawings, and/or newspaper clippings. Be sure to enclose your name, address and telephone number. Don't forget to keep a copy for yourself—everything you send us becomes the property of MacConnection.

Do I win a prize?

But, of course. If we use your Mac story in one of our ads, you'll receive \$500 worth of add-ons and software—your choice. Plus, your name will be up in lights, and your winning smile will be gracing the pages of this magazine.

In the meantime, we're here to offer you the lowest prices, best advice, and strongest customer support available. And to help you fulfill your wildest Mac dreams.

MacConnection™

MacConnection, 14 Mill Street, Marlow, NH 03456 603/446-7711

Callus!

Scarborough Systems

Run for the Money (*Learn business skills to escape from a strange planet. Best with 2 players.*) \$32.
 Make Millions (*Enter the world of high finance and make your fortune.*) 32.

Sierra On-Line

Frogger (*One of the classic arcade-type micro games. For 1 or 2 players.*) 27.

Soft-Life Corp.

Mac-Slots (*An electronic slot machine. Includes Keno.*) 49.

Videx

Collection of familiar, entertaining, and challenging games

Funpak 23
 MacCheckers/Reversi 29
 MacVegas 35
 MacGammon/Cribbage 29

HARDWARE

Assimilation Process

Mac Daisywheel Connection (*Two disks, cable and set up guide for connecting Mac to a daisywheel printer.*) 75.

Compucable

Mac to Hayes Smartmodem Cable (*9 ft length.*) 19.
 Mac to Epson FX/RX printer cable 19.

Creighton Development

ProPrint (*Software for connecting Mac to daisy wheel printer.*) 49.
 ProPrint w/8 ft serial cable 74.
 ProPrint w/28 ft serial cables & A-B switch 149.

Cuesta Systems

Datasaver AC Power Backup (*Keeps Mac operating during line power interruptions or brownouts. 90 watts.*) 239.

Curtis Manufacturing

Diamond (*Switched 6 outlets*) 39
 Emerald (*Switched 6 outlets; 6 ft cord*) 49
 Sapphire (*Switched 3 outlets; EMI/RFI filtered*) 59
 Ruby (*Switched 6 outlets; EMI/RFI filtered; 6 ft cord*) 69.

Elephant

Imagewriter Ribbons (*For superior Imagewriter printing.*) 5.

Epson

RX-80 with GRAFTRAX-Plus call
 RX-80 F/T with GRAFTRAX-Plus call
 FX-80 with GRAFTRAX-Plus call

RX-100 with GRAFTRAX-Plus call
 FX-100 with GRAFTRAX-Plus call

Hayes Microcomputing

Smartmodem 300 (*Works with Macterminal*) 197.
 Smartmodem 1200 (*Works with Macterminal*) 489.
 Compucable's Mac to Smartmodem cable 19.

Hanzon

Universal Card (*Serial interface board that gives your Epson FX or RX series printer Mac compatibility.*) 116.

I/O Design

Padded Imagewriter Carrying Case with shoulder strap. Navy blue. 49.

Kensington

Dust Cover (*Covers both Mac and keyboard*) 10.
 Imagewriter Cover (*Protection for your printer.*) 10.
 Universal Printer Stand (*The perfect companion for your printer.*) 19.
 Swivel (*Lazy Susan style base for your Mac.*) 23.
 Disk Case (*Holds 36 Mac disks.*) 23.

Surge Suppressor (*Replaces Mac's power cord and protects from surges and line noise.*) 39.

Starter Pack (*Swivel, surge suppressor & dust cover in one package. Best buy.*) 54.

Modem (*A 300 baud portable modem. Complete with cases and cables. 5 year warranty.*) 99.

Innovative

Flip & File (*Holds 40 Mac disks.*) 23.

Microcom

MacModem (*Including software, upgradeable to 2400 baud.*) 419.

Micron Technology

MicronEye (*Image sensor translates anything it sees into MacPaint for enhancement, printing, or storage. Let your Mac see what's going on.*) 329.

Pacific Wave

Flip Sort Micro (*Holds 40 Mac disks*) 17.

BASF

Disks 3 1/2" Micro Floppy (*Box of 5*) 19.

MAXELL

Disks 3 1/2" Micro Floppy (*Box of 10*) 35.

Fuji

Disks 3 1/2" Micro Floppy (*Box of 10*) 37.

Memorex

Disks 3 1/2" Micro Floppy (*Box of 10*) \$39.

3M

Disks 3 1/2" Micro Floppy (*Box of 10*) 39.

Verbatim

Disks 3 1/2" Micro Floppy (*Box of 10*) 39.

Intermatrix

Macphone (*The complete computer phone, with clock calendar, memo pad and auto dial. Keeps detailed log of the length of all calls.*) 169.

Microsoft

Apple-Mac Book (*The much-acclaimed Mac reference book. An instant classic.*) 14.

Presentation Graphics Book (*For getting the most out of Microsoft Chart.*) 14.

MacWork/MacPlay (*Twenty original ideas for home and business. See what's really possible between you and your Mac with MacWrite, MacPaint, and Multiplan.*) 14.

OUR POLICY

- We accept VISA and MASTERCARD
- No surcharge added for charge cards
- Your card is not charged until we ship
- If we must ship a partial order, we never charge freight on the shipment(s) that complete the order.
- No sales tax.
- All shipments insured; no additional charge.
- Allow 1 week for personal & company checks to clear.
- COD max. \$1000. Cash or certified check.
- 120 day guarantee on all products.*
- To order, call us anytime Monday thru Saturday 9:00 to 5:30. You can call our business offices at 603/446-7711.

SHIPPING:

Continental US: For printers add 2% to all orders. For all other items, add \$2 per order for UPS surface, \$3 per order for UPS 2nd-Day-Air. We particularly recommend 2nd-Day-Air if you live west of the Mississippi or south of Virginia. In most cases it will only cost \$1 more and will save you up to four days on delivery time. **Hawaii:** For printers, actual UPS Blue charge will be added. For all other items, add \$3 per order. **Alaska and Outside Continental US:** Call 603/446-7711 for information.

MacConnection™

MacConnection, 14 Mill Street, Marlow, NH 03456 603/446-7711

Circle 4 on reader service card

Set...

Chart (Business graphics program transforms numerical data into over 40 different graph styles.) 89.
Multiplan (One of the most tried, proven, and popular electronic spreadsheets.) 125.

Miles Computing

Mac the Knife - Volume 1 (Nearly 500 illustrations — borders, icons, maps, etc. Use with MacPaint.) 27.
Mac the Knife - Volume 2 (Over two dozen new fonts for your Mac.) 29.

Monogram

Dollars & Sense (Personal financial management program for your Mac.) 84.

Organization Software

Omnis 2 (Information management system with global update/delete, user-defined records, mail merge, etc.) 145.
Omnis 3 (Database management compatible with Omnis 2. Supports up to 12 open files.) 219.

Palantir

Mactype (Typing instruction, supports both Qwerty and Dvorak keyboards.) 31.

ProVUE Development

OverVUE (Database program with powerful math capabilities. Can sort 1000 records in 2 seconds.) 185.

RealData, Inc.

Real estate and financial analysis templates. You must have Multiplan to use.

#1 Income producing real estate. 75.
#2 General financial analysis. 75.
#3 Commercial real estate development 75.
#4 Residential real estate. 75.

Reston Publishing

Construction Estimator (Calculates construction costs. You must have Multiplan to use.) 49.

Rio Grande Software

Softmaker II (Write your own Mac software. Well-documented, database program generator for both professionals and amateurs.) 119.

Software Arts

TK!Solver (An equation processing program to help you solve your most difficult problems.) 149.

Software Publishing

PFS:File (Powerful system for updating, recording, retrieving, and printing data.) 79.
PFS:Report (Transfers PFS:File data into reports, according to your specifications.) 79.
PFS:File & Report (Buy both and save.) 125.

Softworks Limited

Softworks C (Turn your Mac into a C language development system.) 279.

Stoneware

DB Master (Complete database management featuring on-screen prompts, browse capability, built-in report generator and more.) \$129.

T/Maker

Click Art Personal Graphics (100+ drawings: cartoons, symbols, borders, famous people.) 35.
Click Art Publications (Graphics for newsletters, reports, invitations and more.) 35.

Telos Software

Filevision (Store visual data along with relevant numbers and text. This unique graphic filing program lets you create a database out of whatever your mind can envision.) 109.

Think Educational

Mind Over Mac (Five challenging games to develop mathematical & memory skills.) 36.
Mac Edge (Learning programs in math and reading using graphics and games.) 36.

Videx

MacCalendar (includes a reminder system to alert you of important messages or notes) 53.

GAMES

Axlon

MacMatch (Match the squares and solve the hidden puzzles underneath.) 34.

Blue Chip

Millionaire (Realistic stock market play. Start investing with \$10,000. Difficulty increases with success.) 37.
Tycoon (Learn to invest in agricultural commodities, precious metals, and foreign currency.) 37.

Baron (Learn the ins and outs of investing in commercial, residential, and undeveloped property.) 37.

Broderbund Software

Lode Runner (Arcade style. Attempt to recover stolen gold.) 27.

CBS

Murder by the Dozen. (12 intricate mysteries. Work alone or in teams against rival detectives or the relentless clock.) 29.

Datapak Software

Turn your Mac into a casino!
Mac-Jack (Electronic black jack.) 27.
Mac-Poker (Electronic poker. Habit-forming when the chips are down.) 27.

Hayden

Sargon III (The ultimate in computer chess. 9 levels of play.) \$35.

Industrial Components

Mac Puzzle (Create your own jigsaw puzzles out of MacPaint drawings.) 27.

Infocom

You're a magician challenging the dungeon master, a detective solving a murder mystery, a scientist deciphering hieroglyphics, or just an ordinary mortal meeting the Wizard of Frobozz. (Difficulty levels shown in italics.)

Seastalker (junior) 27.
Enchanter (standard) 27.
the Witness (standard) 27.
Planetfall (standard) 27.
Cutthroats (standard) 27.
Hitchhiker's Guide (standard) 27.
Zork I (standard) 27.
Zork II (advanced) 35.
Zork III (advanced) 35.
Infidel (advanced) 35.
Sorcerer (advanced) 35.
Deadline (expert) 39.
Starcross (expert) 39.
Suspended (expert) 39.
Invisiclus (hint booklets) are available for all Infocom games. Specify game 7.

Mark of the Unicorn

Mouse Stampede (Blow up the mice and watch them turn into cheese. Addictive.) 23.

Miles Computing

MacAttack (Arcade quality tank simulation. 3-dimensional animation with sound.) 29.

Mirage

Trivia (Over 5000 questions, 5 categories, 3 difficulty levels. Find out what you know, thought you knew or never knew you didn't know. You know?) 29.

Penguin

Pensate (You can control the obstacles, but can you make it to the top of the grid?) 24.
Transylvania (Rescue Princess Sabrina in a desperate race against time, and beware of the creatures of the night.) 24.
The Quest (Rid the kingdom of a vengeful dragon. Great graphics.) 24.

Priority Software

Forbidden Quest (A truly challenging sci-fi adventure. Vivid graphic art prints.) 27.

1-800/Mac&Lisa 435C

MacConnection™

MacConnection, 14 Mill Street, Marlow, NH 03456 603/446-7711

Just the Facts

If you're overwhelmed by the facts of life, a new file management program might help you keep things in perspective

Bill Grout

On-the-job embarrassment often arises from a simple lack of organization. Your boss, for example, may request a few facts on a project you're managing. You know the answers are close at hand, on a note you scribbled to yourself only yesterday. As you feverishly search through the strata of notes on your desktop, your boss stands over you trying to look patient. When you realize the search is going to require serious excavation, you sheepishly tell your boss that you'll send up the information "momentarily."

Factfinder brings order out of desktop clutter without requiring you to drastically change your work habits. The program replaces a cluttered bulletin board, a desk drawer jammed with dog-eared memos, lists of hastily penned reminders, and boxes of file cards. You can still jot down notes and keep track of information in the casual way you're accustomed to. But don't confuse this program with data management systems that handle large business applications such as inventory, payroll, or accounts receivable. *Factfinder* trades the power to sort and search large amounts of structured data for the freedom to record information in an unstructured way.

Factfinder models its functions on the metaphor of a memo pad. You use memo pads for notes, phone numbers, and other impromptu information that you want to remember. Once you make a note, you tear off a sheet and put it in a pile with other notes to yourself. After a while the notes stack up, and you may have to paw through the stack to find a specific note. Like a memo pad, *Factfinder* lets you record information with a minimum of structure, but it also helps you find notes later when you need them. Like a magician snatching a card from thin air, *Factfinder* deftly pulls a note from a stack and displays it on screen.

Factsheets

Factfinder allows you to preserve your spontaneous style of taking notes by letting you record information on notepad-like screen windows called factsheets (see Figure 1). When a factsheet first appears, it takes up about half the Mac's screen. You can stretch or shrink a factsheet the same way that you resize other windows. You can also change the size of a factsheet by clicking the button in the factsheet's lower-left corner. The first click enlarges the factsheet so that it fills the entire screen. By clicking the button a second time, you return the factsheet to half-size. The factsheet window has a scroll bar so you can view notes from beginning to end.

After you move the pointer into the note space and click the window to make it active, you can type text to your heart's content. You type and edit text like you do in *MacWrite*. Text wraps automatically to fit the current window size so that the text doesn't disappear beyond the window's right edge. Notes can be as short as a few words or as long as three to four typewritten pages, depending upon the amount of available memory.

Leaving Clues

When you've finished typing a note, you leave clues to help you find the factsheets and the information they hold. You designate keywords that represent a factsheet's contents and use them to search for it. A budget meeting memo, for example, might be given keywords such as *memo*, *budget*, *meeting*, or a specific word used in the factsheet itself. You can assign as many keywords to the factsheet as you want.



You assign keywords to a factsheet in the Keys window (see Figure 2). At the bottom of the window, you type a word or phrase and then click the Add button to add it to the keyword list. You can also add keywords to the list directly from the factsheet by selecting a word or phrase in the text and typing **⌘-M** or choosing Mark from the Keys menu. Typing **⌘-M** immediately after a word in the factsheet is another way to mark it as a keyword. New keywords appear instantly in the Keys window.

A scroll bar allows you to scroll the keywords in the Keys window, and you can delete keys by selecting them and clicking the Delete button. The top of the Keys window shows a factsheet's creation and modification dates, which can also be used in

searches. *Factfinder* has a feature that automatically adds keywords to related factsheets as they're created so that you don't have to retype the same keywords.

Facts in Stacks

After you complete the factsheet, you name it and save it in a "stack." A stack is one or more factsheets that make up a file. A stack can hold as many notes as disk space allows. You can have any number of stacks, naming and organizing them as your work requires. One stack might deal with notes from business meetings, another with a business project, and others for research notes or tickler lists.

When you want to refer to a factsheet, you load the stack that holds the note and tell *Factfinder* which note you're looking for. You have three ways to review fact-

sheets. The simplest way is to browse through them one by one. You can go forward or backward through a stack by clicking one of the full-page scroll icons located at the bottom of the factsheet window (see Figure 1).

The fastest way to locate factsheets is by using the Names Found window (see Figure 3), which lists the names of all the factsheets in a stack. Scroll through the list to find the factsheet you want and double-click its name. The factsheet should appear within two seconds.

Narrowing the Search

If you already know the name or the modification date of a factsheet, *Factfinder's* search feature lets you call up the factsheet immediately; you don't have to page through factsheets or scroll down the Names Found list. You can also use keywords to search a stack for factsheets covering a specific topic. To perform a search, you type the search criteria in the Find window (see Figure 4). You focus the search by using combinations of factsheet names, dates, and keywords to locate specific or related groups of factsheets. You might, for example, collect all budget meeting notes by searching for the keywords *budget* or *meeting*.

In large stacks it's easy to forget the numerous keywords and names you've given to factsheets to use in a search. *Factfinder* provides an index that lists factsheet names, keywords, and creation and modification dates for each stack. The index appears in a window, and you can order information alphabetically by name or keyword, or numerically by date (see the left side of Figure 4). Clicking an item in the index automatically transfers it to the Find window for use as a search criterion.

Once you have indicated the search criteria, you choose Find Factsheets from the Stack menu, and *Factfinder* begins the search. Searches are slow, taking as long as 20 to 25 seconds to locate one factsheet in a stack of 30. Once the program completes the search, it displays the first factsheet matching the criteria as well as a Names

Figure 1

You type information in factsheets such as the one titled *Meeting Notes* on the left. A single factsheet can have up to four pages of text that can be reviewed on screen by using the scroll bar.

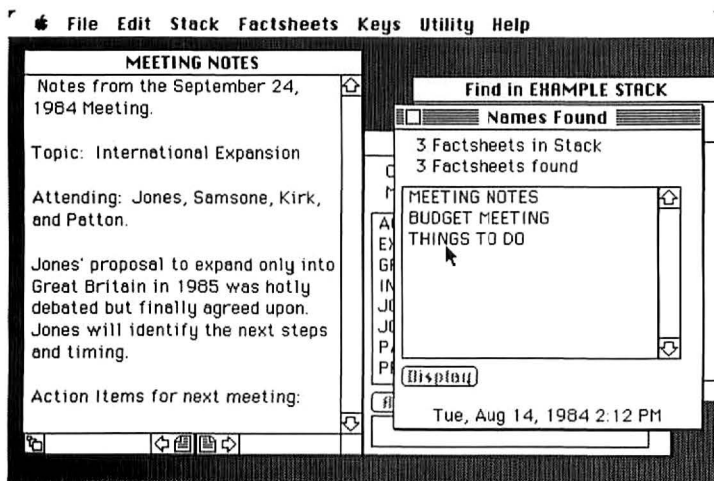
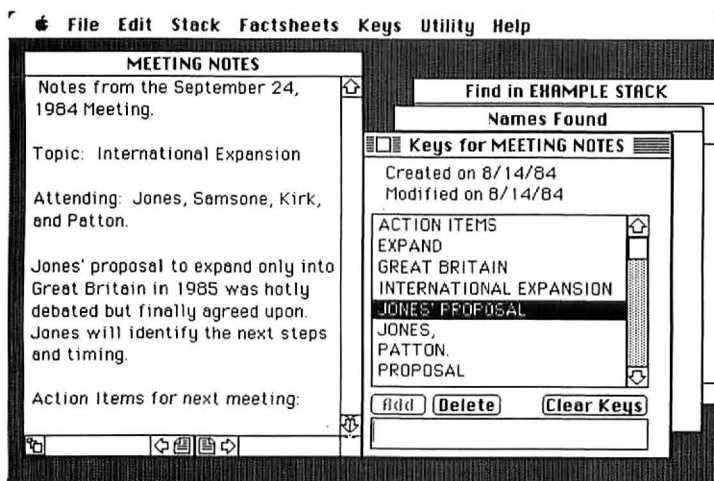
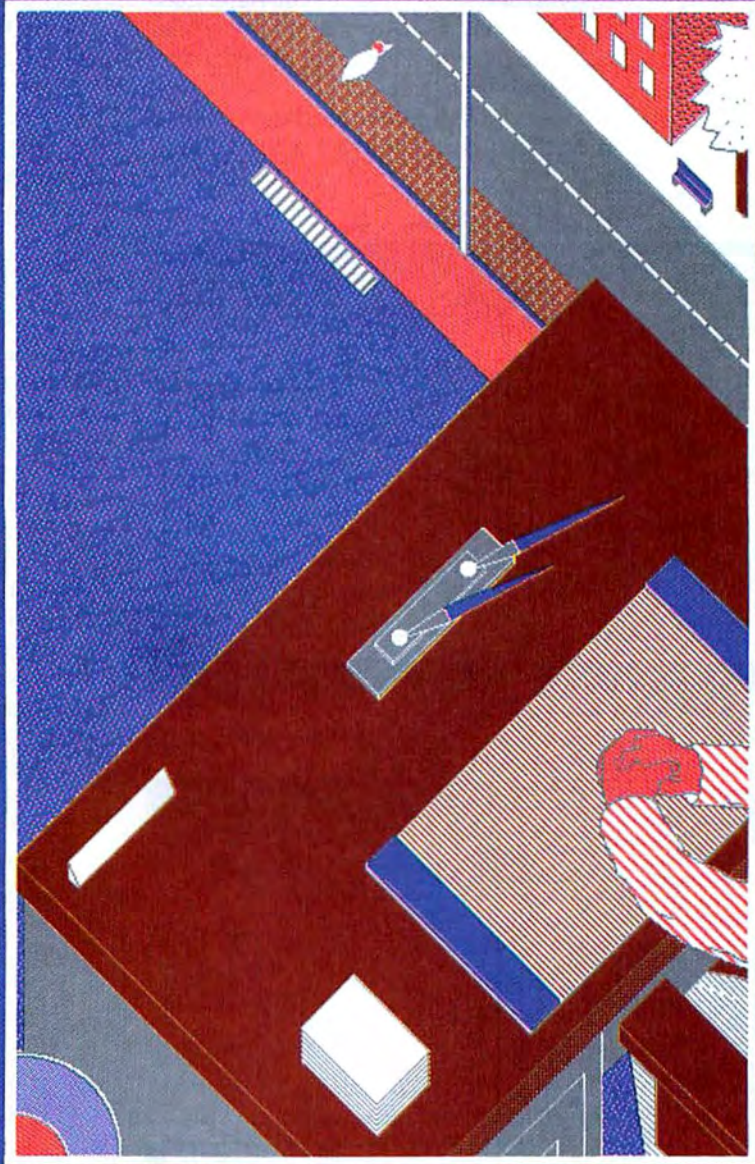

Figure 2

Keywords, such as those listed under Keys for *Meeting Notes* on the right, help you locate factsheets. You assign keywords to a factsheet by typing them at the bottom of the Keys window and clicking the Add box.





Found window that lists the names of all other factsheets meeting the search criteria. You can display any factsheet found in the search by clicking its name.

After you find the factsheets you're looking for, you're not limited to viewing them on screen. You can print factsheets to prepare a set of notes for an impromptu presentation or use them like index cards to form the basis of a report. If you don't want to deal with print menus, you can take quick snapshots of factsheets by pressing **⌘-Shift-4** to dump the current factsheet to the printer.

Freestyle Factfinding

Most file managers and data base programs insist that you record information in a way that maximizes the program's efficiency but may not correspond to the way you normally work. To construct a data base, you have to decide what kind of information you want to store and how you plan to organize it into records and fields. After structuring a typical data base, however, you may discover that you have unanticipated information that doesn't fit into the data base's structure.

Factfinder eliminates the problem of recording information that doesn't fit into a

preconceived scheme, because it doesn't require you to categorize information into records and fields.

I like the way *Factfinder* gives you the freedom to record information in a data base however you like.

Factfinder isn't fast or powerful, but it handles random thoughts, revelations, bits of advice, and lists in the same way as the notepads most people are used to. The pre-release version of *Factfinder* that I reviewed still had a number of bugs, but assuming that the manufacturer applies the proper finishing touches, *Factfinder* might be better suited to your workstyle than a typical data base program would be. *Factfinder* lets you keep the desk clutter out of sight while keeping the facts within reach. □

Figure 3
The fastest way to find factsheets is through the Names Found window, which lists the factsheets in a stack or those located during a search. To look at a particular factsheet, you double-click its name.

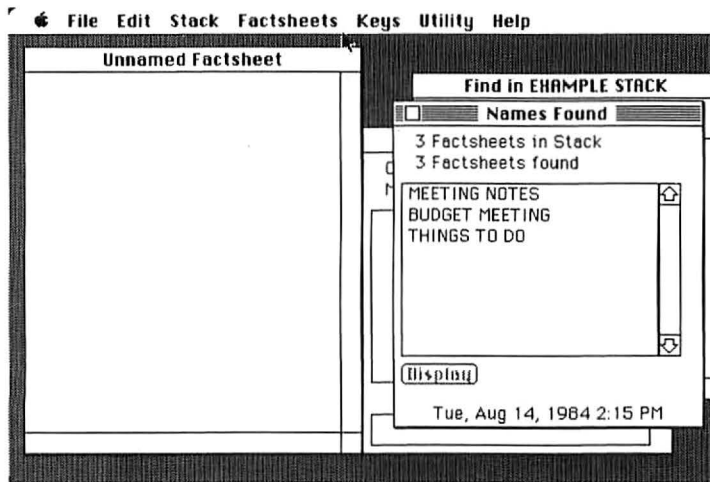

▲▲▲▲▲▲▲▲▲▲ Bill Grout reviews software for the San Francisco Chronicle and has two books forthcoming: *Multi-Mate* and *More!* from Addison-Wesley and *Symphony for Your Business* from Hayden Book Company.

▲▲▲▲▲▲▲▲▲▲
Factfinder
Forethought, Inc.
1973 Landings Dr.
Mountain View, CA 94043
415/961-4720
List price: \$150

Figure 4
The Find window (right) is used when searching for factsheets based on criteria such as names, keywords, or creation or modification dates. An index (left) of current names, keywords, and dates can be called to screen.

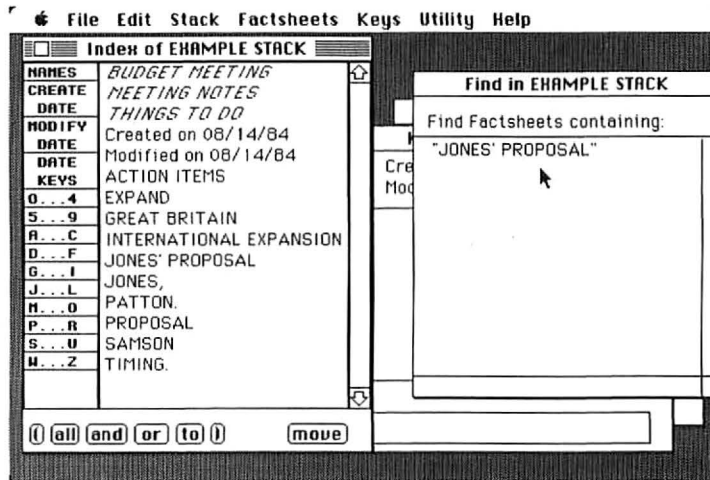

What the critics see in Filevision.™

“...the single most important piece of software to show up since Lotus 1-2-3.™”

The Club Mac News, July 1984

“...for virtually the first time in human history (pardon our gushing), there's a simple way to index ideas via visual images...”

The Club Mac News, August 1984

“Filevision is one of the most impressive uses of the Mac so far ...it shows off the hardware to the hilt.”

“...it perfectly embodies the spirit of the Mac in making information accessible and comprehensible for the rest of us.”

“Almost as importantly, it sets a standard for other developers, and consumers will come to not accept anything less.”

Guy Kawasaki
“Software Evangelist”
Apple Computer, Inc.

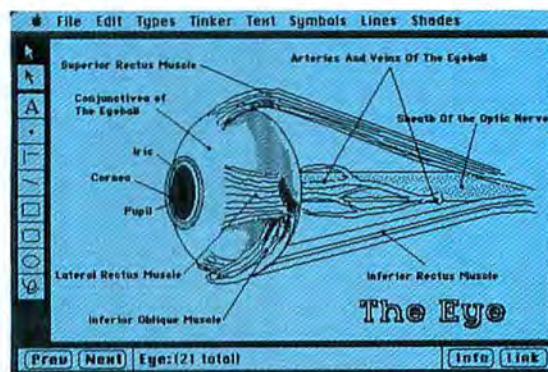

Here's what they saw when they looked into technical drawings. Data forms connected to each object in the picture.

Esther Dyson
RELEASE 1.0

“It is Filevision's unique integration of object-oriented drawing and data base functions that give it the edge over other stand-alone graphics or data base applications.”

MacLine, September 1984

“Filevision is a first. It's a program whose career is as a database manager, but whose heart is in art.”

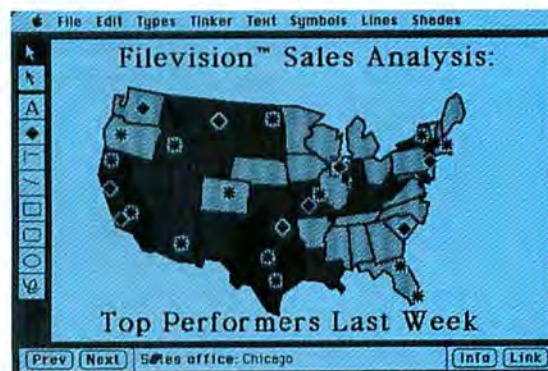

For business, they saw how to map sales regions and track volume. And print out sales reports, in the click of a mouse.

“Filevision... can quite honestly be called the first independently developed program to deliver on the “Macintosh™ promise”...”

Kevin Goldstein, Softalk

from anywhere in the U.S., call 1(800) 554-2469.

Within California call 1(800)368-3813.

TELOS™
SOFTWARE PRODUCTS
Software for the real world

Filevision is a trademark of Telos Software Products. Lotus 1-2-3 is a trademark of Lotus Development Corporation. Macintosh is a trademark licensed to Apple Computer, Inc. Telos is a trademark of Telos Corporation.

Circle 54 on reader service card

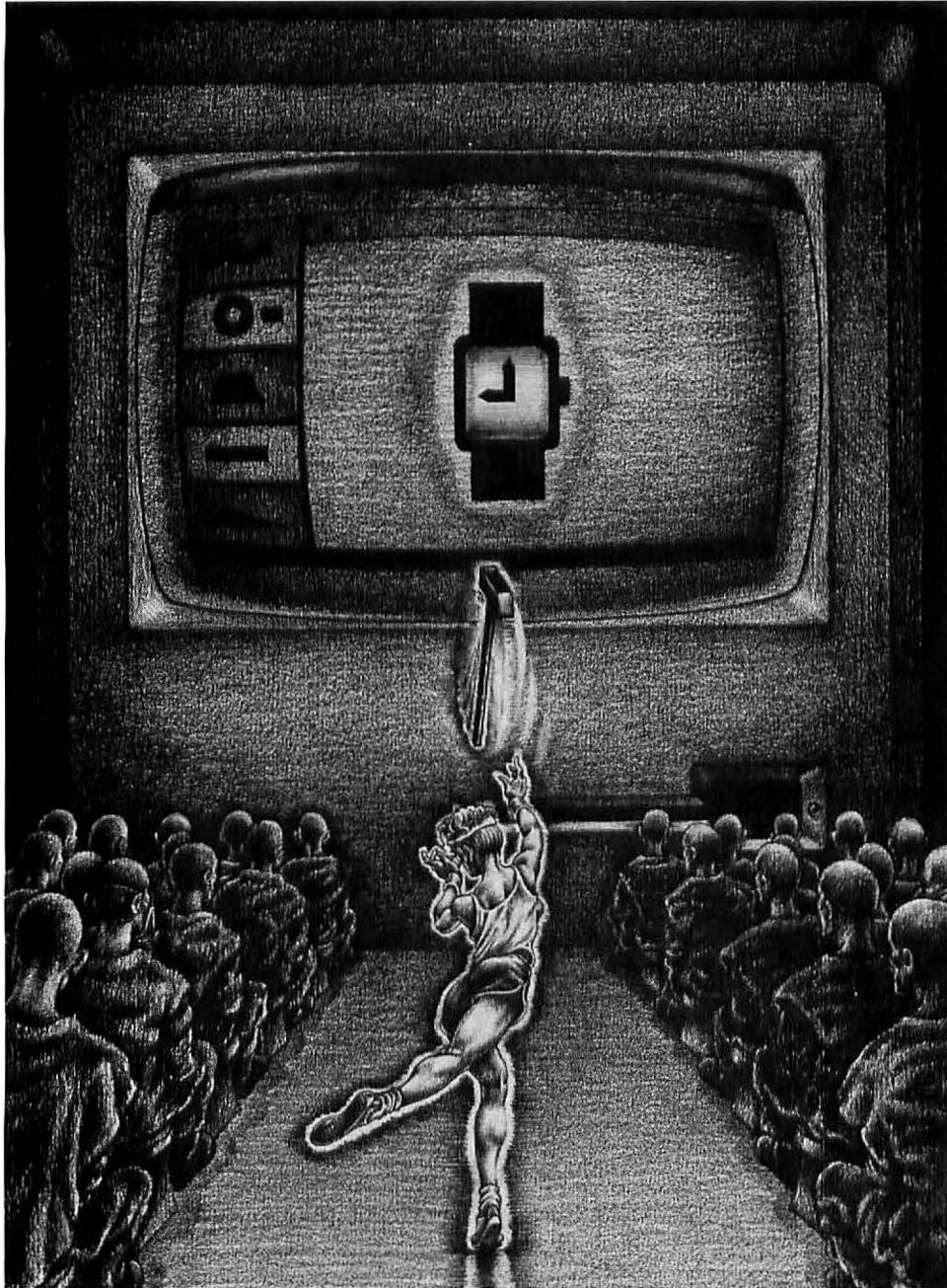

Beat the clock.

Your ordinary Mac™ spends an extraordinary amount of time talking to itself. And all the while, all you can do is stare at the clock.

Which is no way for you to spend your time.

So get your Mac a HyperDrive™. The only Winchester made to go inside your Mac.

A HyperDrive will get your Mac going at least three times faster. So for example instead of waiting 20 seconds to load MacWrite™, you'll be off and running in under seven seconds.

A HyperDrive will hold as much data as 25 Mac floppies. So you can have more programs, more files right where you need them, whenever you need them.

And because HyperDrive is internal, there's one less component to lug around, one less wire to break, and one more port free for other things.

And yet it costs less than other Winchester systems that don't do nearly as much.

So what are you waiting for?

For the name of your closest HyperDrive dealer, call 800-422-0101.



Circle 176 on reader service card

Macintosh and MacWrite are trademarks licensed to Apple Inc.
HyperDrive is a trademark of General Computer Co.

How to Mac Music

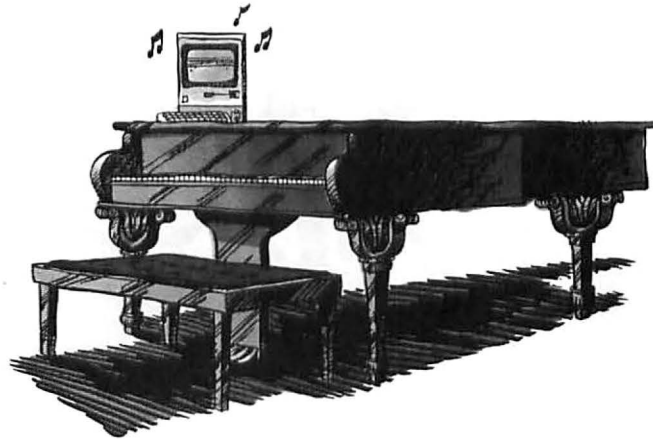

Creating original music is a joy. Creating sheet music is anything but.

With that in mind we introduce a major breakthrough in music making. Professional Composer. From Mark of the Unicorn.

Professional Composer is an easy-to-use software program that lets you score, edit and print music using Apple's new Macintosh personal computer and mouse. Developed especially for musicians (not just computer virtuosos), Professional Composer requires no computing experience whatsoever. Instead it simply requires that you know how to point.

You see, Professional Composer puts a blank piece of manuscript paper on your computer screen. Then it lets you use the Macintosh mouse, a small rolling box that controls a pointer on the screen, to enter clefs, notes, rests, time signatures and chords. Even ties, beams,

slurs and note ornaments. In fact anything that would be part of a published score.

Using the same mouse, you can edit your music too. Delete and insert notes, accents, clefs, time and key signatures. Move instantly from one part of your score to another. Change keys. Even listen to what you've written. Of course you can file your music too, complete or incomplete, so it will be easily accessible the next time inspiration strikes.

But perhaps best of all is the finale. Because with Professional Composer and Mac's beautiful graphics, you can print out sheet music that's the envy of any professional copyist. And the objective of every serious musician.

If you'd like to hear more on how Professional Composer can help you make music, write Mark of the Unicorn, 222 Third Street, Cambridge, MA, 02142, or call 617-576-2760.



Professional
Composer

Mark of the Unicorn, 222 Third Street, Cambridge, MA 02142, 617-576-2760

Circle 31 on reader service card

How to Keep Your MacintoshTM from Frying to a Crisp

Protecting Your Hardware From The 6,000 Volt Destroyer

Over 50% of all hardware and software complaints received by manufacturers have nothing at all to do with product quality. To the contrary, most damage reported is caused by surges in household or business current.

A surge is a short duration increase in voltage that can reach to 6,000 volts or more and lasts anywhere from less than a microsecond to several milliseconds. These surges occur both from line to line and line to ground.

What makes surges so insidious is that they occur so quickly that the operator is unaware of their occurrence. These surges will continue to degrade the sensitive microcircuitry and the result is lost data and, even worse, computer repairs that are often mistakenly blamed on original equipment failure.

Caused by utility switching, changes in electrical loads and lightning as far away as five miles, surges can also disrupt data transferred within the computer and can wipe out portions of memory.

30,000 Volts At The Tip Of Your Finger

Another common danger to the computer, its peripherals and software, is common static electricity. Like powerline surges, this source of raw power is often put off by the operator as being little more than an annoyance. Few people realize that their bodies are carrying as much as 30,000 volts of electrical power. This power, though not going directly through your system, can pose as great a threat as powerline surges.

The Faulty Ground

In addition to operator safety a properly grounded computer is better able to drain off charges that would otherwise create dangerous voltage levels between the computers chassis and microcircuitry. Again, the operator is typically not aware of whether the outlet is properly grounded and therefore risks both the operator's safety and hardware damage.

RFI Can Play Havoc With Your Image

While RFI (Radio Frequency Interference) is not a source of damage to computer or operator, it can play havoc with the monitor image and to software. Caused by nearby radio stations, the operator's own radio or television, as well as other electrical devices, the RFI shows up on the monitor as a scrambled image. It may also appear as software that has been garbled while in memory. If for no other reason, the computer operator should guard against RFI simply because its effect can nullify the time-saving benefits provided by the computer.

MacGard: Real Protection For The Serious User

MacGard from Systems Control is the single most complete computer protection device available today. MacGard is designed by the same engineers who have been providing custom protection and control to the nation's power companies for two decades. From its inception, MacGard was designed with Macintosh in mind. From its quality injection molded plastic casing which compliments your Macintosh's appearance, its at your fingertips convenient placement on the side of your unit, and its combination of superior protection features, the MacGard is the ultimate system accessory for your Macintosh.

MacGard provides the serious user with a complete series of protection benefits.

- It clamps off all line to line and line to ground surges *before* they can enter your system.
- It provides an anti-static pad you need only touch to safely drain off up to 30,000 volts of harmful static.
- It provides an LED ground indicator to indicate proper grounding of your electrical outlet.
- It provides RFI attenuation to assure a clean monitor image and software safety.
- A master on-off switch provides the convenient control to power up your computer and up to two other peripherals.
- MacGard has a one year limited warranty.
- If you're not satisfied within 30 days, return MacGard for full refund.

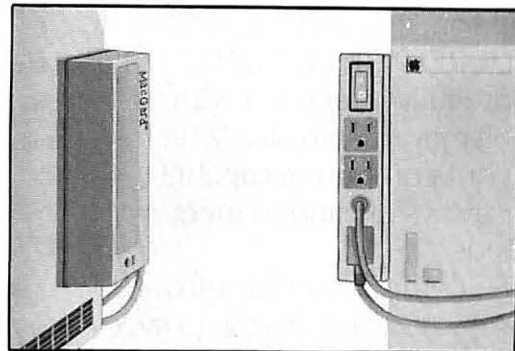

If you're a serious user, you owe it to yourself to own a MacGard. Your MacGard can only be purchased directly from Systems Control. Cost of the MacGard is \$89.95 plus \$3.50 for shipping and handling. To order or request more information, call toll free, 1-800-558-2001 Ext. 115, in Wisconsin, 1-800-242-3102 Ext. 115. We accept both Visa and MasterCard. No C.O.D.

Systems Control P.O. Box 788 M Iron Mountain, MI 49081

MacGardTM

THE MOST USEFUL IDEAS ARE OFTEN REMARKABLY SIMPLE.

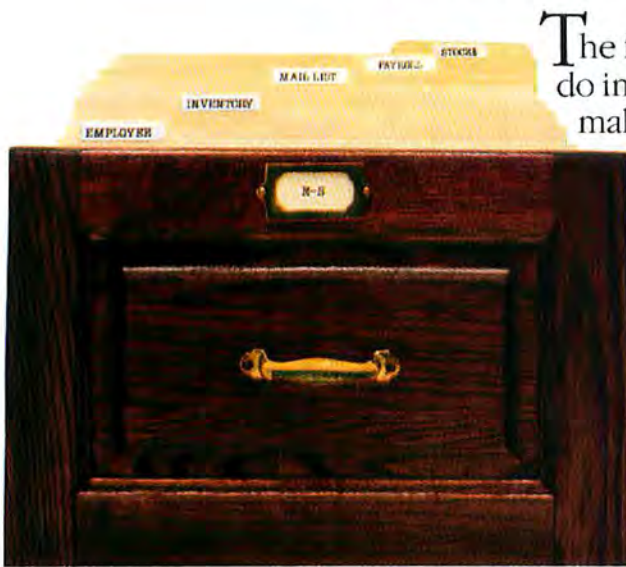

The first filing system was a remarkably simple way to do incredibly useful things. Like organize a business and make it work.

PFS®:FILE and PFS:REPORT are remarkably simple software programs that can help you organize your business faster and more effectively.

And both programs are amazingly easy to learn.

FILE and REPORT were designed for people without computer experience. So all instructions are easy to understand. And you can be productive quickly.

FILE lets you record, retrieve and review information like personnel records and purchase orders. Instantly. You can even cross reference by department or job or however you want.

And you can arrange information in "forms" you design yourself. Or you can take advantage of PFS SOLUTIONS which are pre-designed forms for popular applications like inventory, invoices and ledgers. Either way, you can quickly and easily create the filing system that fits your needs. Not your computer's.

REPORT is the perfect companion program to FILE. Because it gives you the power to summarize and perform calculations on information you've stored with FILE.

With REPORT, you can create presentation quality summaries in table form in just minutes. Automatically sorted, calculated, formatted and printed!

FILE, REPORT and SOLUTIONS are fully integrated with the PFS Family of Software. Which means your computing capabilities can always expand to meet your needs.

PFS: It's the powerful software that's simple to learn. It's the power of simplicity.

See your computer dealer for more details.

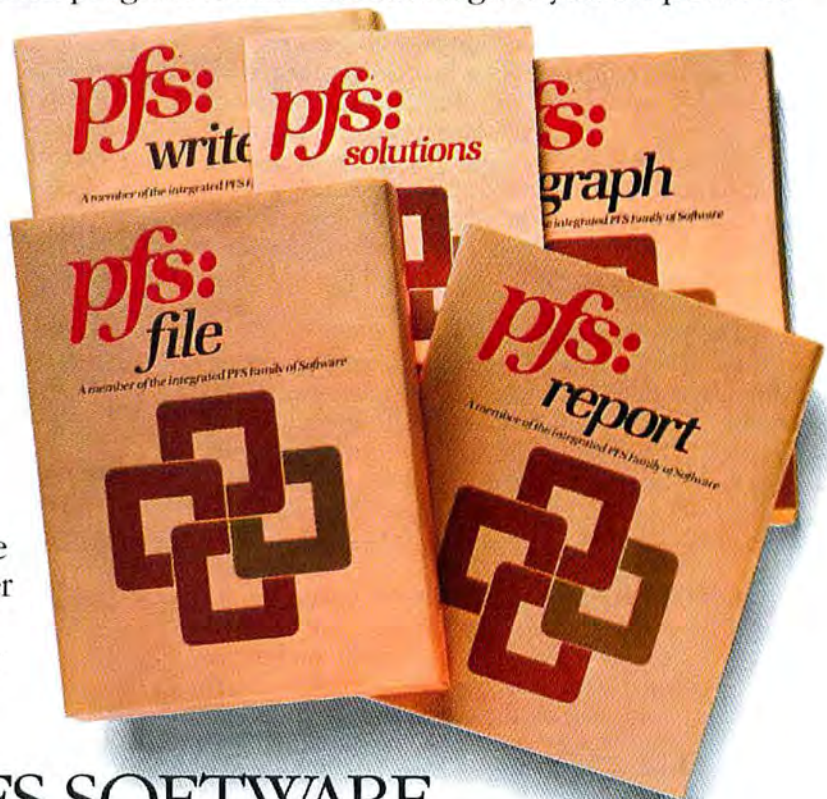

PFS SOFTWARE THE POWER OF SIMPLICITY

PFS:FILE and PFS:REPORT currently work on Apple, IBM, Macintosh, Tandy, Commodore, DEC, Gavilan, Hewlett Packard, NEC, Panasonic, Polo, Texas Instruments, Compaq, Chameleon, Columbia, Corona, Eagle and Hyperion personal computers.
*Does not work with PFS SOLUTIONS

Macware News

The latest developments in Macintosh software, hardware, and accessories

Edited by Erfert Nielson

Macware News announces new Macintosh products. Those listed here are available now or will be in the near future. We will keep you informed of developments as the number of products for the Mac increases.

Software

■ **Abacus Concepts**

2735 Clay St. #3
San Francisco, CA 94115
415/931-7037

StatView

A visually oriented data analysis package that offers both graphic and tabular views of data and results. *StatView* provides descriptive statistics, comparative statistics, non-parametric tests, and curve fitting, as well as full arithmetic data transformations, sorting, and display of several probability values. You can cut and paste data and graphs between *StatView* and other applications such as *MacWrite* and *MacPaint*. List price: \$99.95.

■ **Apple Computer**

20525 Mariani Ave.
Cupertino, CA 95014
800/538-9696, 800/662-9238
in California

Through the Looking Glass

An animated game in which you play Alice and are pursued by enemy chess pieces. You must dodge the attacking pieces, which move in actual chess patterns, and capture as many as you can. At the beginning of the game, you set the speed of play and give Alice the powers of any piece. You move Alice by clicking a pointer on legal destination squares; you can also use the pointer to select several undocumented modes of play. *Through the Looking Glass* also lets you design your own playing pieces and define their movements. List price: \$39.95.

■ **Button-Down Software**

P.O. Box 19493
San Diego, CA 92119
619/462-0365

Profit Stalker

A program that performs technical analysis of stocks and commodities. *Profit Stalker* generates charts from a relational data base that stores stock and commodity price information. The charts include daily open-high-low-close, moving averages, volume line and bar, open interest, 3- to 13-

day oscillators, daily most active, member trading, free reserves, money growth, and discount rate. The program requires Microsoft BASIC. List price: \$150.

■ **Forethought, Inc.**

1973 Landings Dr.
Mountain View, CA 94043-0808
415/961-4720

Typing Intrigue

A typing course that can track up to six learners. The program provides constant updates on speed, accuracy, and problem keys, allowing users to determine which areas need work

and to concentrate on exercises geared toward those areas. *Typing Intrigue* provides basic exercises for beginners as well as refresher courses for more experienced typists. The program includes a mystery story, *The Case of the Missing Bathtub*, to help keep learners interested. You can buy clues to the mystery with points that are awarded during the instructional portion of the program. Also included is *Rain*, an arcade-style game that makes use of typing skills developed in the drills and exercises. List price: \$49.95.

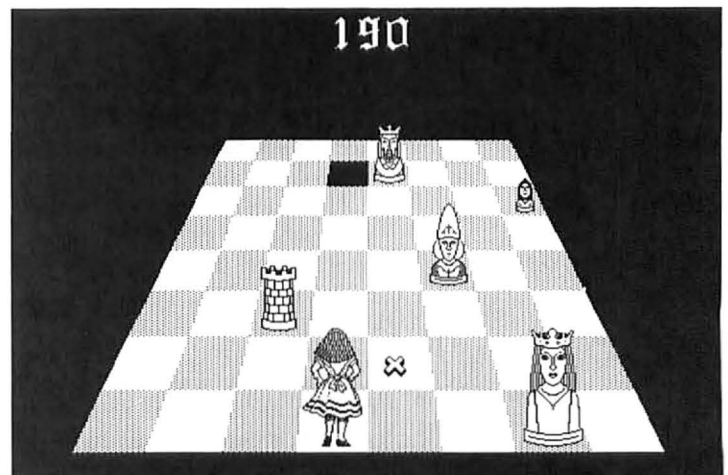

Through the Looking Glass, Apple Computer

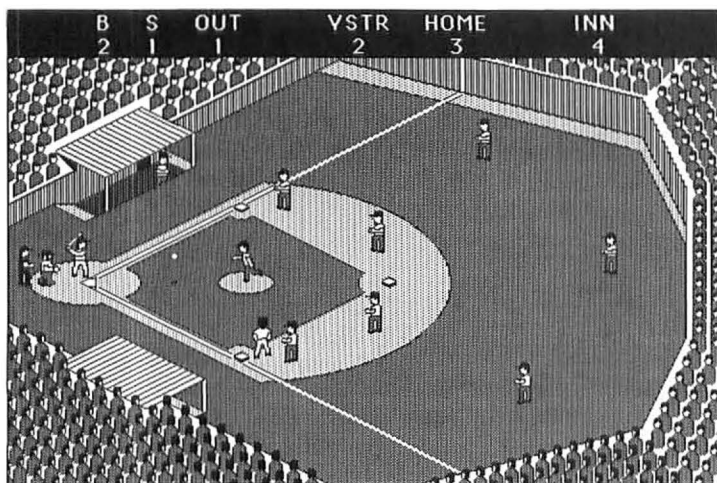

Star League Baseball, Gamestar

■ **Gamestar, Inc.**

1302 State St.
Santa Barbara, CA 93101
805/963-3487

Star League Baseball

An animated baseball game for one or two players. When playing against the Mac, you use the mouse to control the ball-players' movements. In a two-player game, the player at bat uses the keyboard as a game controller and the other player uses the mouse. Players can choose a batting lineup and a starting pitcher and can bring in a relief pitcher if necessary. The batter has a choice of swinging or bunting, and the pitcher can choose among eight pitches. The game includes music and sound effects. List price: \$34.95.

■ **Harvard Associates, Inc.**

260 Beacon St.
Somerville, MA 02143
617/492-0660

DeskToppers

A set of desk accessories that you can install in any application with an Apple menu. *DeskToppers* includes Calendar, which allows you to view any month of any year from 1904 to 2003; Little Black Book, which maintains up to 26 pages of

names, addresses, and other information sorted alphabetically; Doodle Pad, a sketchpad that lets you add a drawing directly to a document or paste it into the Scrapbook for future use; and Music Maker, which lets you choose a xylophone, clarinet, trumpet, or organ and play notes with the mouse (tunes are recorded automatically as you compose them). List price: \$49.95.

■ **Hayden Software Company**

600 Suffolk St.
Lowell, MA 01853
617/937-0200

Hayden:Base

A relational data base management system that stores text, numeric data, and *MacPaint* illustrations. Variable-length data fields can contain single or multiple entries. Using overlapping windows, you can view several files at once. If you change information in one file, *Hayden:Base* automatically updates related information in up to 15 files. File size and the maximum number of records and fields possible are limited only by available memory. List price: \$149.95.

■ **Layered, Inc.**

85 Merrimac St.
Boston, MA 02114
617/423-9041

Front Desk

A business calendar that can be viewed in day, week, or month format. *Front Desk* is designed to help business people gauge an office's workload, track hours spent on specific tasks, and report or project revenue generated from various activities. The program maintains schedules for up to 15 employees for up to 12 months, and provides time-accounting information (for example, how much revenue an employee produced in a given period). You can define standard hourly business rates for each resource scheduled; the program uses these rates to calculate total revenues generated from each source. You can also define up to 15 standard services (such as title search, physical examination, or report generation), which are assigned a flat billing rate or an hourly fee. List price: \$149.95.

■ **Lotus Development Corporation**

161 First St.
Cambridge, MA 02142
617/492-7171

Jazz

An integrated package that includes five business functions: word processing, worksheet analysis, data base management, business graphics, and communications. *Jazz*, which runs on the 512K Macintosh, offers keyboard equivalents for common mouse actions, allowing you to keep your hands on the keyboard. The program can display multiple windows. *Jazz's* word processing function can be combined with the data base function for mail merging, with the worksheet to create reports containing both text and tables, and with graphics to insert illustrations into text. The worksheet has 8192

rows of 256 columns; several worksheets can be opened at once. The data base can be combined with the communications function to capture and subsequently analyze information. The data base allows you to use forms to enter, edit, and view information, and includes a report generator. The program's graphics function provides six types of graphs that can display information from the worksheet or the data base. *Jazz's* asynchronous communications function lets the Mac emulate DEC VT-52 and VT-100 terminals. You can send and receive information from *Jazz* worksheet or word processing documents, as well as convert information from *1-2-3*, *Symphony*, and *Multiplan* files. List price: \$595.

■ **Miles Computing**

7136 Haskell Ave. #300
Van Nuys, CA 91406
818/994-7901

Mac Attack

An animated game that puts you at the controls of a Sherman tank. You must defend a city against enemy tanks and aircraft, maneuvering your tank to dodge heat-seeking missiles. You use the mouse and the keyboard to control the speed and direction of your tank as well as cannon turret aiming and firing. List price: \$49.

■ **Northwest Analytical**

520 N.W. Davis St.
Portland, OR 97209
503/224-7727

NWA StatPak

A statistics package that lets you use the Macintosh for data management, data manipulation, statistical and mathematical computation, and reporting. *StatPak's* ASCII text files are compatible with *MacWrite* and are suited to commu-

communications and network environments. In addition to data file entry and management, you can perform functions such as seasonal adjustment, lag/leading, rank ordering, subset selection, and data transformation. Computational functions include probability calculations, descriptive statistics, frequency studies, cross-tabulation, regression and correlation, means testing, distribution analysis, non-parametrics, and ANOVA. Microsoft BASIC is required, and an external disk drive is recommended. List price: \$395.

■ Scarborough Systems

25 N. Broadway
Tarrytown, NY 10591
914/332-4545

Make Millions

An economics simulation game in which you manage a company. You make decisions regarding manufacturing, inventory, pricing, and selling; the game's object is to make your company's stock price the highest in the market. The resources at your disposal include stock quotations, news-

papers, market research, spreadsheets, data bases, and business consultants. You must cope with changing economic conditions and labor relations while administering a growing team of managers and executives. As you build your business, the competition is also growing and bidding against you for scarce resources needed to manufacture products. List price: \$49.95.

■ Scientific Software 2 Sequoia Tree Ln. Irvine, CA 92715 714/786-8366

PersonalAid

Three programs that require Microsoft BASIC. FileAid is a file management program that can handle up to 15 fields. FileAid provides editing capabilities and data manipulation utilities such as search, sort, arithmetic operations on numeric fields, and tabular display and printing. WriteAid is a line editor suitable for letters and memos. FileAid files can be merged with WriteAid documents. DeskAid is a desk accessory that includes a phone book, a to-do list, a notebook, and an appointment book. List price: \$34.95.

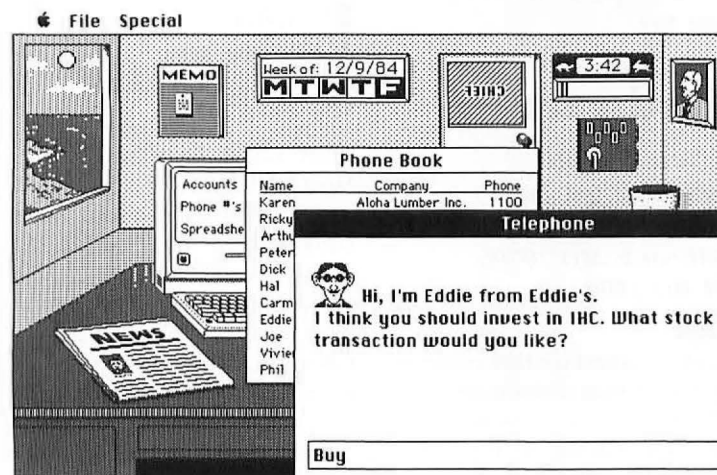

Make Millions, Scarborough Systems

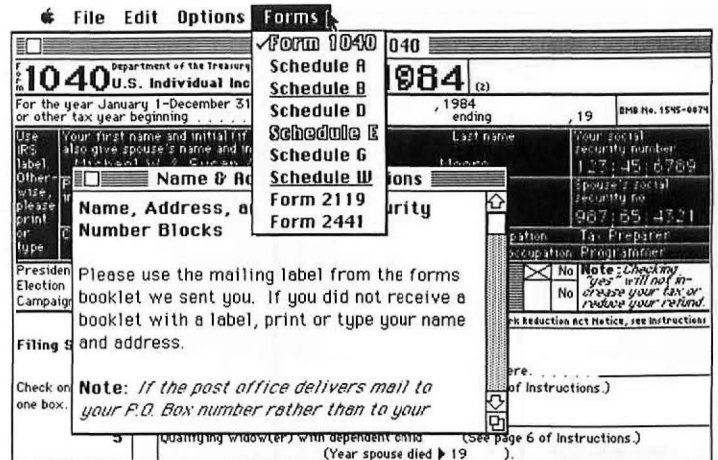

MacInTax, SoftWeave Company

■ SoftWeave Company 400 Mobil Ave. Bldg. D, Ste. C Camarillo, CA 93010 805/388-2626

MacInTax

A federal income tax program for individuals. You use the mouse to move to the appropriate sections of the displayed form, then enter information. Calculations are performed automatically. MacInTax includes the complete IRS instruction book on disk; double-clicking an item gives you access to the instructions and worksheet for that item. Information can be printed on a standard IRS form, or the program's form, including your calculations, can be printed on a blank sheet of paper. List price: approximately \$75.

■ Textco 27 Gilson Rd. West Lebanon, NH 03784 603/643-4267

DNA Inspector

A set of Microsoft BASIC programs for analyzing genes. The programs provide a rapid means of analyzing the structure of genes and manipulating different DNAs or DNA fragments. DNA Inspector allows recombinant DNA experiments to be designed with the com-

puter before they are attempted in the lab. The programs can perform complete restriction enzyme and base composition analyses and can search for specific sequences, palindromes, or possible protein coding regions. Different genes or DNA fragments can be joined to produce recombinant DNAs that can be analyzed further. The package includes the DNA sequence of several recombinant DNA vectors. List price: \$109.

■ Videx, Inc. 1105 N.E. Circle Blvd. Corvallis, OR 97330 503/758-0521

Mac Vegas

A disk containing seven casino games: Baccarat, Blackjack, Craps, Keno, Poker, Roulette, and Slots. Players can choose house rules from among four casinos that offer variations in betting limits and odds. The games feature animation and sound, and you use the mouse to drag chips into position. The package includes an instruction manual and a book on casino gambling. List price: \$59.

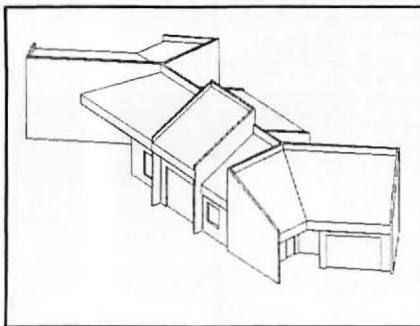

TEKALIKE

A Graphics Terminal
for the Macintosh™

- Easy mouse interface
- Tektronix emulator
- Cut mainframe graphics to MacWrite and MacPaint
- Mainframe compatible to IBM, DEC, ...
- Software compatible to ISSCO, SAS/GRAPH, Precision Visuals, SPSS/GRAPH, Plot 10...
- Supports:
 - Picture Recording
 - Zooming
 - Plotting
- Also Versions For:
 - Apple Lisa
 - Apple //

Mesa Graphics

P.O. Box 506
Los Alamos, NM 87544

\$250
Circle 97 on reader service card

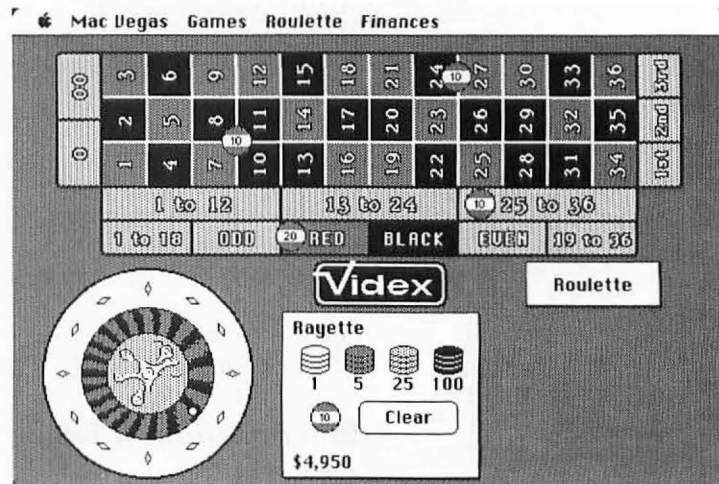

Mac Vegas, Videx

■ **Zeta Gen Software**
320 Corbett Ave.
San Francisco, CA 94114
415/864-4127

ScreenGen

A set of Microsoft BASIC programs that allow you to build formatted screens for your own applications. The programs allow you to enter text, select one item from a group, and toggle an option on and off. After you have designed your screen, a BASIC source file is written to disk; the file contains the code to display and capture entered data and to return it to your BASIC program. List price: protected code \$39, full source code \$99.

Hardware

■ **New Image Technology, Inc.**
10300 Greenbelt Rd.
Seabrook, MD 20706
301/464-3100

Magic

A camera interface that enables you to connect a black-and-white or color television camera to the Macintosh. Images captured by Magic can fill an

entire screen (512 by 342 dots). Features include a fast-focus mode (five frames per second), a mouse-driven camera interface, a connector for real-time monitoring of incoming video signals, and the ability to stretch or scale incoming pictures. The program allows you to enter *MacPaint* directly, without returning to the desktop. A black-and-white television camera with a 16mm f/1.6 lens and a C-mount adapter for 35mm lenses is available. List price: interface, software, cables, and camera \$495; without camera \$350.

■ **Qubie'**
4809 Calle Alto
Camarillo, CA 93010
805/987-9741

212A/1200E External Modem

A 300/1200-baud modem that is compatible with Bell 103/212A standards and features auto-answer and auto-dial. The modem sends and receives information automatically with software such as *MacTerminal* or

Crosstalk. The 212A/1200E includes a user guide, a modular phone cable, and a Macintosh interface cable. List price: \$329.

Accessories

■ Alpenlite

3891 N. Ventura Ave.
Ventura, CA 93001
800/235-3410, 805/653-0431
in California

Disklite Cases

Nylon carrying cases for 3½-inch disks. Disklite 3 holds 6 disks, and Disklite 5 holds 12 disks. The cases are made of nylon and have a water-resistant coating, Velcro closures, and expandable nylon mesh pockets. The cases are available in navy blue or pewter. List price: \$14.95.

■ Channel Productions

315½ W. Pendregosa St.
Santa Barbara, CA 93101
805/569-0034

Computer Graphics Color Packet

A package containing eight 6-by-9-inch self-adhesive sheets of different colors. You can use these transparent film sheets to add color to charts, graphs, and *MacPaint* artwork. Slides of the color graphics can be used in presentations. The package includes a graphics blade for cutting the film sheets. List price: \$15.

■ Diablo Valley Design

4103 Hidden Valley Rd.
Lafayette, CA 94549
415/283-1082

MacGrid

An on-disk tutorial on using a grid system to transfer drawings or photos to the Macintosh screen. The grid enables you to maintain the proportions of the

original artwork in *MacPaint*'s full 8-by-10-inch drawing area. The package includes a grid on a clear plastic overlay, which you recreate on the Mac's screen. The training disk provides tips for working with *MacPaint* and suggestions for creating ad layouts. List price: \$39.95.

■ Ferro Enterprises

P.O. Box 2151
La Jolla, CA 92038
619/456-2213

Paper Saver

A device that stops tractor-feed paper from curling into the Imagerwriter's single-sheet slot and jamming the printer. The plastic Paper Saver slips into the printer's single-sheet slot and can be lifted out when you are printing on individual sheets. List price: \$6, wide-carriage model \$8.



Paper Saver, Ferro Enterprises

Teleservice Telesupport

PRODUCT	RETAIL PRICE	MICRO FLASH
Ashton-Tate dBase II	\$ 495	\$ 369
Assimilation Process		
Mac Turbo Touch	129	109
Continental Home Accountant	150	119
Creative Solutions MacFORTH	149	98
Dow Jones Straight Talk	75	57
Haba Systems 3.5" HabaDisk	450	369
Hayden Publishing Sargon III	50	38
Human Edge Mind Prober	50	38
Sales Edge	250	169
Infocom Zork II	50	38
Intermatrix Macphone	199	170
Jomega Bernoulli Box 5 MB	1895	1599
Living Videotext ThinkTank	145	110
Maxell 3.5" Diskettes	65	49
Microsoft® Multiplan™	195	125
Basic Interpreter 2.0	150	99
Chart	125	89
Word	195	148
File	195	148
Miles Mac the Knife Vol. 2	49	39
Monogram Dollars & Sense	150	113
OSC Omnis 2	275	210
Omnis 3	375	285
PFS File & Report Package	195	148
Prometheus ProModem w/Mac Pac	549	425
Stoneware DB Master	195	148
Telos Filevision	195	148
Tecmar 5 MB Removable	2295	1695
T/Maker ClickArt	50	35
Videx Mac Vegas	59	49

MANY OTHER PRODUCTS AVAILABLE! CALL AND DISCOVER WHY OUR LOW PRICES, FAST SERVICE AND WELL-STOCKED INVENTORIES HAVE MADE MICRO FLASH THE CHOICE FOR CORPORATE BUYERS!

MICRO FLASH GUARANTEE: We sell the latest versions, we support what we sell, and if a product is defective when you receive it — we'll replace it!

MICRO FLASH TERMS & SHIPPING: MasterCard or Visa — no extra charge. Call for information on purchase orders. \$100 minimum order. Prices subject to change. UPS surface \$6.00 (except printers and monitors). Add \$3.00 per item for UPS 2nd Day Air. Call for information on foreign orders, US Mail, COD's, & overnight delivery service. All shipments fully insured at no extra charge.

For product information, price quotes, technical support, please call

415/680-1157

To order from outside California, call

800/458-2433

Telex #353199 MFLASH UD



COMPUTER SYSTEMS, INC.

1110 BURNETT AVE., SUITES J & K
CONCORD, CA 94520

Circle 3 on reader service card

Member: Better Business Bureau
Chamber of Commerce
Listed: Dun & Bradstreet

IF YOU CAN'T TYPE, YOU CAN'T COMPUTE

Your computer productivity is directly proportional to your speed at the keyboard. That's why *Typing Tutor III™* with *Letter Invaders™*:

- Automatically adjusts to your abilities and progress;
- Tests words, numbers, and full keyboard, as well as through a standard speed test;
- Features *Letter Invaders*, an arcade-style game that lets you take an entertaining break while sharpening your typing skills at the same time.

Called "the most miraculous of programs" by **The Whole Earth Software Catalog**.

Available for the IBM PC, Apple II/II+ /IIe/IIc, Apple Macintosh, and Commodore 64 wherever software is sold.

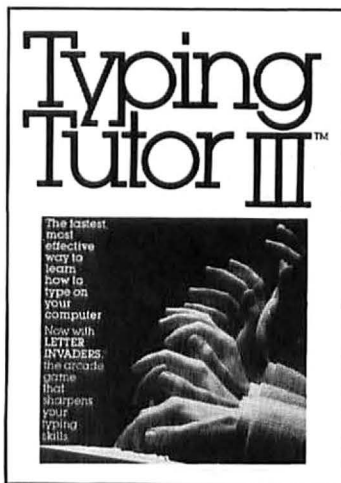

BY KRIYA SYSTEMS,™ INC.

SIMON & SCHUSTER

Typing Tutor III, Letter Invaders, and Kriya Systems, Inc. are trademarks owned by and licensed from Kriya Systems, Inc.

Simon & Schuster
1230 Avenue of the Americas
New York, NY 10020

Circle 198 on reader service card

■ *The Reference Corporation*

212 Fifth Ave. #1312
New York, NY 10010
212/685-4809

Iron-On Transfer Ribbon

A black ribbon that enables you to make iron-on transfers from *MacPaint* drawings. You insert the ribbon into the Imagewriter in place of its normal ribbon and print your design onto a sheet of paper. You then place the paper face-down on a T-shirt or other article of clothing and apply a hot iron. List price: \$17.50 plus \$3 shipping and handling.

■ *Sharp Color*

400 N. High St., Box 175
Columbus, OH 43215
614/221-0502

Iron-On Transfer Ribbon

A black ribbon cartridge that enables you to make iron-on transfers from *MacPaint* documents. You insert the cartridge in the Imagewriter, print your drawing on a sheet of paper, and apply a hot iron to the back of the paper to transfer the image to a T-shirt. List price: \$18.

Notes

■ *AppleTalk*

Apple's network, which has been referred to as AppleBus for several months, has been renamed the AppleTalk Personal Network. Each device in a network requires an AppleTalk cable connector set, which retails for \$50.

■ *Do-It-Yourself Upgrade*

MassTech Development Labs is selling a 512K conversion kit for the Macintosh. The kit includes an instruction manual, a Memex-512 PC board with 16 IC sockets, a tool for removing the

Mac's cover, a memory test program, and a RAM disk. You must desolder the Mac's 128K chips and solder in the new chips, which voids your warranty. The basic kit, without 256K chips, sells for \$49.95 (plus \$3.50 shipping and handling); the kit with 16 256K chips sells for \$599.95 (plus \$5.50 shipping and handling). For more information, contact MassTech Development Labs, 451 Boston Rd., Groton, MA 01450, 617/448-3450.

■ *Correction*

The price for Peachtree Software's *Back to Basics* accounting package was listed incorrectly in the November issue's *Macware News*. The General Ledger module, which is available now, sells for \$175. Accounts Payable and Accounts Receivable will be available in the first quarter of 1985; at that time the three modules will be sold as a single package (owners of General Ledger will be able to upgrade their packages). The price for the three-program package was unavailable at press time. For information on prices and availability, contact Peachtree Software, 3445 Peachtree Rd. NE, Atlanta, GA 30326, 800/554-8900.

Macware News uses information provided by manufacturers; it does not evaluate products or corroborate manufacturers' claims. Send a description and a photograph of your new product to Macware News, Macworld, 555 De Haro St., San Francisco, CA 94107, 415/861-3861. □

MOUSE MEETS MODEM.

The first mouse wanted a modem that would be very Macintosh-like. Icons and all.

The second mouse wanted a modem that could talk to its brothers at IBM.

The third mouse wanted a modem that could take over while its owner was sleeping.

The fourth mouse wanted a 1200 baud modem that could be inexpensively upgraded to 2400 baud.

The fifth mouse wanted a modem that worked error-free on anybody's phone service, even the discount ones he was afraid to use.

A difficult series of requests, to be sure.

But not impossible. Because today, there is a modem that will make your mouse very, very happy. It's called MACMODEM. It's made just for the Macintosh. And it's the only modem that can satisfy mouse 1, mouse 2, mouse 3, mouse 4 and mouse 5.

Two clicks and your mouse will be in and out of your favorite data base with exactly the information you want. A job that takes an awful lot of clicking and keystrokes with any other modem.

To see it in person, visit your local Apple dealer and ask for MACMODEM. If he hands you something else, don't go for the bait. Call 1-800-322-3722. Microcom, Inc., Norwood, MA 02062.

MACMODEM™
MICROCOM

MACINTOSH IS A TRADEMARK OF APPLE COMPUTER, INC.
IBM IS A TRADEMARK OF INTERNATIONAL BUSINESS
MACHINES CORPORATION
MACMODEM AND MICROCOM ARE TRADEMARKS OF
MICROCOM, INC.

Circle 72 on reader service card

Finally! A Cure For The Big Blues...



Oh the sorrow. Accounting programs so difficult to operate that the small businessman doesn't have the time to become a big businessman. That's Big Blues. Only known cure—MACCOUNTANT.™

MACCOUNTANT Sweats The Details.

Like the Macintosh™ it was specifically designed for, MACCOUNTANT proves that simple doesn't mean simple minded. It's a ferocious number cruncher that's been civilized, so MACCOUNTANT works for you, you don't work for it. Ledgers and statements, payables and receivables all set up the way **you** are used to seeing them. An eye for detail is what MACCOUNTANT is all about. In fact, in many cases, MACCOUNTANT won't let you make a mistake.

Your MACCOUNTANT Is Very Punctual.

MACCOUNTANT is on time—any time. From ratios to receivables, the information you need is as close as a tap of the mouse. Always on call, day or night, no appointments and no hourly fee!

...FREE!

So, if your accounting program has got you down, break away from the Big Blues, and take the cure. It's FREE! Simply call our toll-free number and we will send you further information on MACCOUNTANT and a coupon for a free MACCOUNTANT demo disk. If you're still in the process of purchasing a computer, may we suggest some preventative medicine... take the demo disk to your local Macintosh dealer for a FREE demonstration.

You needn't suffer Big Blues. MACCOUNTANT has cured even the toughest cases. Call 1-800-922-7500. Help is on its way.

MACCOUNTANT™

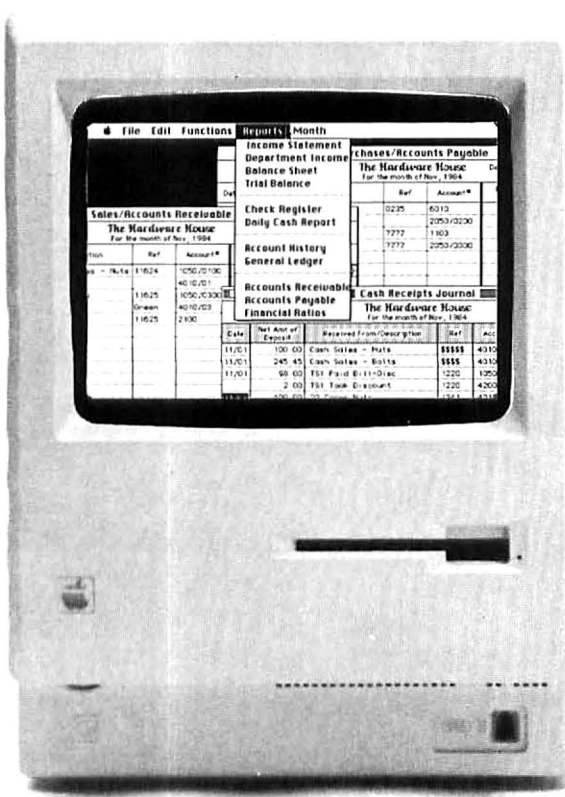

Includes: Income Statement • Departmental Income Statement • Balance Sheet • Trial Balance • Check Register • Daily Cash Report • Accounts Payable Vendor History • Accounts Receivable Customer History • Accounts Payable Aging • Accounts Receivable Aging • Financial Ratios and much more for only \$195!

SPECIFICATIONS SUBJECT TO CHANGE

MACINTOSH is a trademark of Apple Computer, Inc.

DIGITAL ETC. SOFTWARE PRODUCTS

etc

Circle 190 on reader service card

The Worlds of Ann Arbor Softworks

Macintosh™ software.

While they waited, we designed.
While they promised, we developed.
While they delayed, we delivered.

Macintosh software from Ann Arbor Softworks.
Like nothing you've ever seen before.
Powerful. Innovative. And incredibly easy to use.
Software created by people who really understand the Macintosh.

Worlds for you to create. The Animation Series. Programs to redefine what we mean by communication. In everything from engineering to art, the concrete to the abstract. **Animation Toolkit 1 - The Players** laid the groundwork. **Animation Toolkit 2 - The Stage** finishes the task. Pure picture power for interactive, real-time, visual design.

Worlds to amuse and excite you. The Entertainment series. Putting our graphics expertise to work in new and exciting ways. Construction sets, games, simulations, and more. Each a work of software artistry. Each exactly Macintosh. **Lunar Explorer** and **Laser Hopper** (the gentleman, below), are our first two offerings.

Worlds waiting to be discovered. The Future. Ann Arbor Softworks has an aggressive plan to bring powerful graphics software to the microcomputer community. Pictures and motion. In two or three dimensions. With a dedication to producing the very best.

With the Macintosh. Apple has created a machine of unparalleled power. A machine that demands equally powerful software. Ann Arbor Softworks accepts that challenge. To be better. In design. In implementation. In support. With a company commitment to do things right the first time. Because there's no such thing as second best.

Animation. Entertainment. Exploration. Worlds to create, amuse, and discover.

Worlds within worlds.

Macintosh software from Ann Arbor Softworks.
Because what's the sense of using a computer to make things harder?

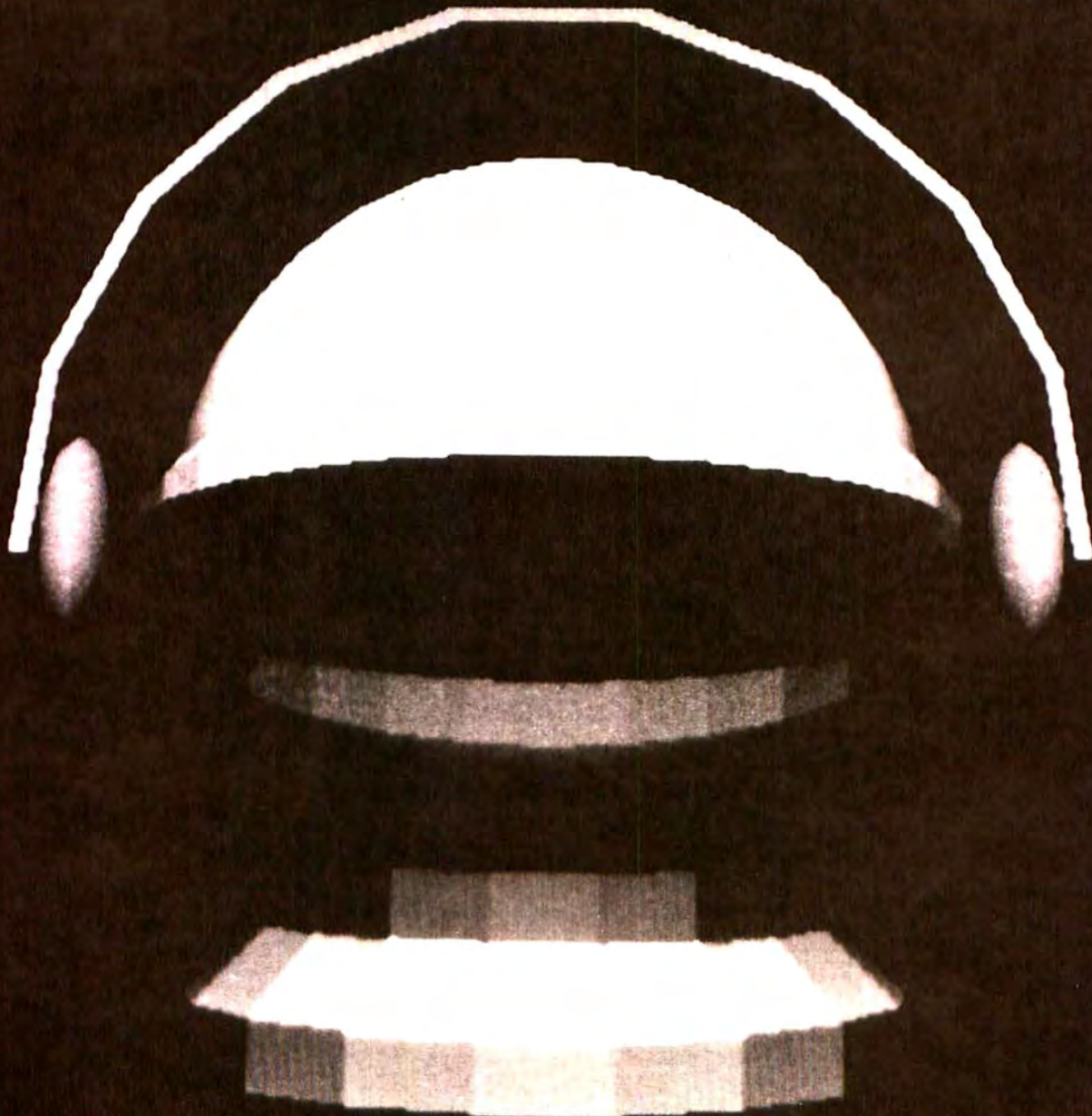

Macintosh is a trademark registered to Apple Computer, Inc.
Animation Toolkits 1 & 2, Laser Hopper, and Lunar Explorer are trademarks of Ann Arbor Softworks, Inc.

Circle 204 on reader service card

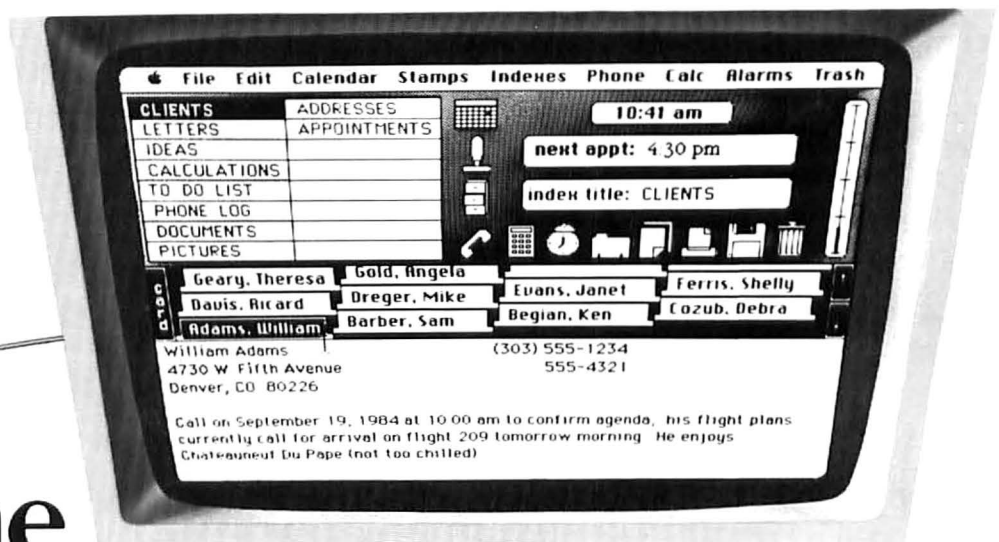

The only complete desk management system for your Mac.

THE DESK ORGANIZER is the only software program that can completely organize your busy life. With a total system of powerful desk management functions that work together—THE DESK ORGANIZER makes you more productive day in, day out.

It's your instant file cabinet. Expanded notepad. Appointment calendar. Telephone dialer. Printer. Visual calculator with paper tape. Clock watcher. Your infallible electronic secretary.

THE DESK ORGANIZER even runs alongside other software. So, whether you're working on a spreadsheet, word processing, or Macintosh graphics, it's always available to organize you.

Let it do your support work, while you do the thinking and planning. Boot it the first thing each morning... and rely on it all day.

NOT JUST A SET OF TOOLS—A COMPLETE DESK MANAGEMENT SYSTEM

THE DESK ORGANIZER's amazing tools work together—to provide one convenient environment for storing and utilizing all your work.

Designed around a powerful free-form filing system, THE DESK ORGANIZER's correspondence,

telephone dialer, scheduling calendar, calculator and other functions share information interactively.

IT FULLY EXPLOITS THE POWER OF THE MAC... AND THEN EXPANDS UPON ITS CAPABILITIES.

Now, your Mac's limited notepad is replaced by THE DESK ORGANIZER's extensive correspondence facility. The Mac's alarm clock is incorporated into THE DESK ORGANIZER's full time management system. And THE DESK ORGANIZER greatly increases the filing capacity of the Mac by enabling you to store and organize hundreds of Mac notes and letters on a single diskette.

IT WORKS THE WAY YOU DO.

THE DESK ORGANIZER is the best friend you and your Mac can have. Because all its powerful functions are user-tailorable.

Let's face it: Life could stand to be more organized. And THE DESK ORGANIZER stands ready to help.

Discover THE DESK ORGANIZER for yourself. Go to your favorite software store or call Warner Software, Inc. at (212) 484-3070.

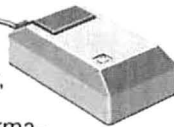

Warner Software presents:

THE Desk Organizer[®]

for the Apple Macintosh



ONLY \$149*

* suggested retail price

"THE DESK ORGANIZER is a superb software package." —InfoWorld

Warner Software, Inc., 666 Fifth Ave., New York, N.Y. 10103

Circle 183 on reader service card

Improve Your Balancing Act.



At last. Personal finance software you can really use. To help you stay on top of your bills. Get a good grasp of your personal financial situation. And save you valuable time.

The Electric Checkbook by State of the Art is bill-oriented to set up and record your bills on a one-time or recurring basis. It gives you the choice of either computer or hand written checks. Working with you and your Macintosh,TM the Electric Checkbook can selectively pay who you want, when you want, with the exact amount you want. Quickly and more easily than any other personal finance software.

With the Electric Checkbook, you can log all the activity in your checking accounts with computer accuracy. Perform bank reconciliations automatically. And analyze income and expenses by category. What's more, you can even produce detailed personal financial statements.

And the Electric Checkbook is easy to learn because it takes advantage of all the Macintosh features. Our illustrated, tutorial-style documentation was especially written for the novice user.

Let the Electric Checkbook keep your personal finances in perfect balance. After all, you've got better things to do with your time.

For more details on the Electric Checkbook, stop by your authorized Apple dealer today.



STATE OF THE ART.

State of the Art, Inc.
3191-C Airport Loop
Costa Mesa, CA 92626
(714) 850-0111

The Language that Talks to Your Printer

Richard Sprague

Typesetting the printed page is an art form requiring as much skill and attention to detail as fine sculpture or classical painting. Even the untrained eye can probably tell the difference between a poor printing job and a professional one. Compare, for example, the fine lettering and page layout of an entry in the *Encyclopaedia Britannica* with the look of your local newspaper. The structure of the encyclopedia page seems more refined.

Producing printed output of near-professional typeset quality has been a problem on printers used with personal computers. Apple's Imagewriter printer, for instance, can reproduce the fonts and graphic images you see on the Macintosh screen in almost perfect detail, but the bit-mapped fonts are still of lower quality than that required for most business and professional applications. The problem of



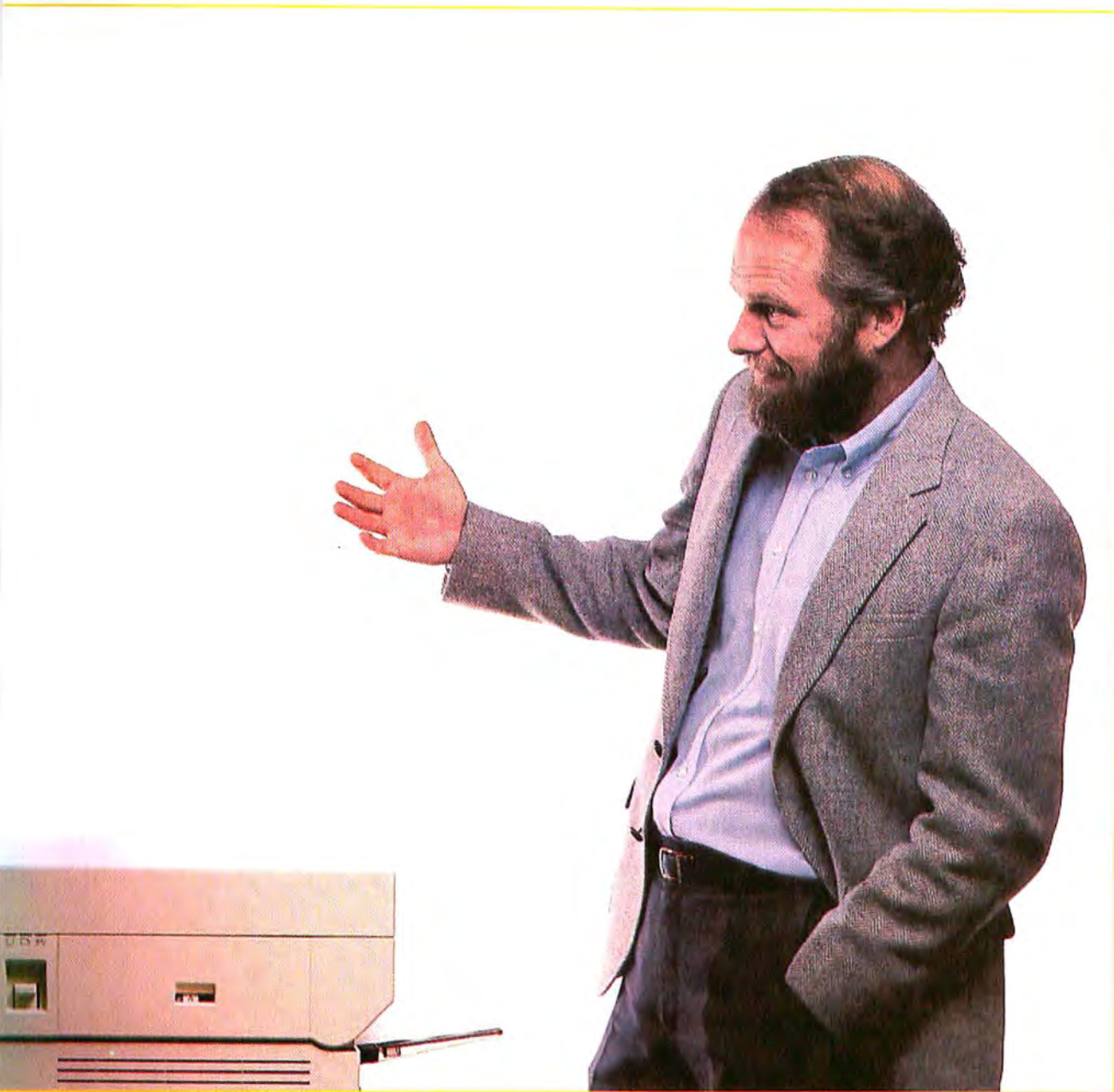

Producing professional-looking text and graphics on the LaserWriter is possible due to a unique programming language called PostScript developed by Adobe Systems in Palo Alto, California. Created by John Warnock (right) and Charles Geschke (left), PostScript is especially adept at describing the appearance of pages in documents. The language specifies graphics and character shapes (fonts), their orientation, and their placement on the page. It also describes graphics shapes (lines and areas) and specifies their position, scale, and orientation. Several companies, including Apple Computer, have adopted PostScript as the standard printing protocol for producing high-resolution output.

Producing high-quality output with the LaserWriter involves an ingenious language called PostScript developed by Adobe Systems of Palo Alto, California. Adobe is licensing PostScript as an interpreter to companies like Apple and Quality Micro Systems (QMS), which are developing printer devices. As a language, PostScript has been adapted as the standard printing protocol for producing high-resolution output by Apple as well as by companies such as Microsoft and Lotus Development Corporation (see "The PostScript Horizon" for a look into PostScript's future).

The Adobe Approach

The geometric algorithms required to rotate and scale graphics and text images have been used for many years by programmers working on graphics simulation programs.

◆◆◆◆ *PostScript is a full-scale programming language with graphics capabilities that make it ideal for drawing fonts and graphics.*

Adobe's president, John Warnock, originated the idea for PostScript over six years ago and continued to develop it while he worked at Xerox Corporation and Evans and Sutherland, a graphics simulation company. Evans and Sutherland has long used high-speed computers and complex mathematical algorithms to produce the realistic simulation programs used by aerospace companies for training pilots.

Other computer scientists have been developing sophisticated word processing systems for designing fonts and typesetting pages of text. At Stanford University Donald E. Knuth designed a system named TEX that is used for typesetting books. Knuth's system provides ways to design fonts with a mathematical language called Metafont. Unfortunately, TEX and similar typesetting systems are extremely complicated and require a great deal of time to learn before they can be used effectively.

Teaming up with Charles Geschke, an expert in programming environments, and other people with extensive backgrounds in computer graphics, Warnock founded Adobe Systems to continue the development and application of the PostScript concept. Warnock and his colleagues realized that many typesetting programs were genuine languages, but with programming capabilities that were constrained to handle text only.

Many word processing programs, for example, have ways to set variables, do looping, and define macros (sequences of instructions that may be used repeatedly in a program). Most typesetting programs limit the macros you can define or allow only a fixed number of variables. The process of preparing pages for printing is divided into rigidly defined modes for lines, sentences, or paragraphs. These constraints on the languages made them difficult to use. PostScript is different from other typesetting languages: it is a full-scale programming language with graphics capabilities that make it ideal for drawing fonts and graphics.

Another problem in producing high-quality printing is that almost all printers have incompatible ways of displaying text and graphics. Most personal computer programs get around the incompatibility problem by saving documents in "print files," which are independent of the printer connected to the computer. The output is produced with the aid of a program designed to read the print file for the particular printer in use. Most applications use a *static* print file format, a sequence of fixed operators (printer control codes that determine paper motion and the placement of characters), followed by the actual data to be printed.

With PostScript, Warnock and his associates decided to use a *dynamic* print file format to make their language overcome the incompatibility problem. A dynamic format has procedures and variables that are executed by an interpreter built into a printer such as the LaserWriter. As the terms suggest, a dynamic print file is a more flexible format than a static print file. As a result, complex page images of both text and graphics can be printed more easily.

The Revolution in PostScript

The beautiful artwork involved in creating a fine font is impressive when you consider that the traditional way of designing fonts requires that a new set of characters be created for each size and style (such as boldface or italic) of the font. If there are 100 characters in a font and you need three sizes, a total of 300 different characters must be crafted. A complete boldface set for the font requires another 300 characters—a total of 600 individual characters for one typeface in three sizes and two styles.

Most laser printers use this traditional method of designing fonts when printing text. Separate fonts must be created for a specific face, size, and rotation (such as 12-point Times Roman italic or 14-point Helvetica). Also, each character in a font is tuned, or optimized, for the printer's resolution. This method of building and tuning fonts is time-consuming, and the fonts require a substantial amount of memory for storage. Another drawback is that fonts cannot be scaled or rotated. Also, because the fonts are resolution-dependent (tuned for a particular printer's resolution), they become obsolete as technology improves to allow for higher-resolution printing.

PostScript revolutionizes the font creation process by having font characteristics represented geometrically only once in the computer. The LaserWriter's memory, for example, contains the Helvetica typeface—not the actual characters, but the attributes of the typeface in outline form. The PostScript language automatically adjusts the characters to produce

them in different sizes and rotations at any resolution. Fonts can be assembled in an infinite number of ways—all perfect and completely unique to the application for which they are created.

The concentric ring of words in the figure "Infinity Circle," for example, is composed of carefully set Helvetica characters. Such a high-quality job without PostScript would cost a master typesetter many months of labor, as he or she carefully tuned each character to fit perfectly into its space on the page while still retaining its unique features.

PostScript makes creating a font image easy because the language treats character information the same way that it treats graphics information—as tiny lines or curves on the page. PostScript's font set is composed of 151 glyphs (shapes such as an A or a



Infinity Circle
This spiral of Helvetica characters was created on a VAX minicomputer and downloaded to a LaserWriter printer. You can't produce this design with MacDraw or MacPaint, but it illustrates PostScript's ability to produce fonts in any size or rotation.

comma) that allow for the creation of more than 250 characters. An object, such as a page of text, can be represented in different sizes, styles, or positions, but the essential characteristics of the object remain the same. Unlike *MacPaint*, which treats objects in terms of their individual bits on the screen, PostScript, like *MacDraw*, treats objects as structured shapes in relative locations. For example, instead of describing a particular Helvetica *T* as an object whose stem is 10 dots high topped by a crossbar 8 dots wide, PostScript captures the essentials of the Helvetica *T* by describing an object whose stem is topped by a crossbar that is 20 percent shorter. By storing font information in terms of outlines, rather than individual dots, PostScript is able

◆◆◆◆ Like FORTH,
PostScript is an extensible, interactive programming language in which you can build and test parts of a program.

to reproduce characters in any size or rotation by geometrically transforming the outlines. The page description features of PostScript make it ideal for “imaging” pages consisting of text, line graphics, and filled area graphics, as well as pages that contain photographic images. In fact, PostScript can define any page, no matter how complex.

Inside PostScript

PostScript is powerful because it is a true Turing-equivalent programming language, capable of many more kinds of operations than graphics output. To computer scientists, Turing equivalence means a mathematical description of the most powerful class of functions and languages known. Put more simply, a Turing-equivalent language is capable of computing any function or expression that can be computed at all. It would be possible (and actually not at all difficult), for example, to write a Pascal compiler or LISP interpreter in PostScript.

The name *PostScript* is partly a play on words—a reference to the language’s use of postfix notation for passing arguments and data from one procedure to the next by means of a stack. This design is similar to FORTH, and in fact PostScript is a fairly close cousin to MacFORTH. If you’re already familiar with FORTH, you’ll get used to PostScript in no time at all.

Like FORTH, PostScript is an extensible, interactive programming language in which you can build and test parts of a program, step by step and in progressively larger segments, until you have a truly sophisticated system. The major difference between the two languages is that PostScript’s syntax is more friendly than FORTH’s. Since FORTH programs are meant to be run repeatedly, the language does everything necessary to make programs compact and efficient, even if the programmer has to do a little extra work learning the syntax. PostScript programs, on the other hand, typically run only once—to produce a final laser-printed copy of a page—so the compactness of the syntax is not a primary concern. Thus, PostScript’s syntax is less obtuse and easier to read. The extra friendliness comes at only a slight cost in speed: PostScript’s designers estimate that programs in the language run at a respectable one-fifth of the speed of a super-efficient C-compiled program.

PostScript contains an extensive array of built-in commands, or *operators*. The language has a full set of mathematical functions, including random numbers and trigonometric functions. A complete set of string-handling operations is available, with searching and stripping functions. The many file input/output operators make PostScript a hospitable programming environment even before you get to the graphics parts of the language. PostScript’s graphics operators are divided into five major groups:

- *System control operators*. This group manipulates the Graphics State, a data structure maintained by the PostScript interpreter that holds the current graphics control parameters. These operators provide an effective way of switching between contexts defined by the other groups of graphics operators.

- *Coordinate system operators*. The Graphics State has a transformation matrix that maps coordinates that you specify into coordinates suited to the printer or other device in use. This group of operators manipulates the matrix to allow for translation, rotation, and scaling of the graphics coordinates into the printer device coordinates.

- *Path construction operators*. PostScript maintains a *current path* data structure for defining shapes and line trajectories for output. Paths represent two images: geometric outlines of areas to be filled with an image or a color, and trajectories along which lines

(continues on page 112)

The PostScript Horizon

Lisa B. Stabr

While the LaserWriter may be the state of the art in personal computer printers, it is PostScript that gives it that distinction. In time many printers will likely contain PostScript in their memories. The majority of Macintosh software, such as *MacWrite*, *MacPaint*, *Microsoft Chart*, *Multiplan*, and *pfs:file*, already take advantage of the LaserWriter's capabilities.

Bill McGee, product manager for the Macintosh version of *Microsoft Word*, says, "If we are to be the serious word processor for business, we need to be compatible with the LaserWriter."

In time major application programs designed for personal computers other than the Mac will make use of PostScript's power, using printers like the LaserWriter. A flurry of new programs written specifically for PostScript-equipped computers can be expected in the next year. Most of these programs will make document creation easier for novices than it is now, and they will include features that allow Mac owners to design their own stationery or to lay out pages for typesetting output.

PostScript has had a profound effect on the printing industry as well. Already some of the best-known manufacturers of printers and copiers are working on their own PostScript-equipped printers. These new printers will be faster and more dependable and will have higher resolution than the LaserWriter. Most will also take advantage of PostScript features that the LaserWriter does not, such as color printing and the ability to produce fonts as small as 1 point (the LaserWriter has a practical lower limit of 4 points). Of course these printers may cost substantially more than the LaserWriter.

One feature that PostScript-equipped printers will have is the ability to download fonts into the printer's memory. Adobe Systems plans to make the complete line of fonts from Mergenthaler, the world's oldest and largest typeface company, available to printers equipped with PostScript.

PostScript will affect typesetting as a trade. Because the language works with a phototypesetting machine as easily as it does with a printer, PostScript files, such as book manuscripts, can be generated on any personal computer and sent directly to a typesetting system. Some people think that the need for phototypesetting services will diminish as high-res-

olution, PostScript-equipped printers are introduced. Others believe that typesetters will become more specialized than they are today. Even the laser printers of tomorrow won't have the high-quality, 2500- to 5000-dots-per-inch resolution that phototypesetting machines already have. Likewise, although printers can spew out as many copies as needed, they will never be able to produce as fast as typesetting equipment can. In any case, PostScript will most likely become the de facto standard language for generating printed output from personal computers to all kinds of printer devices.

Lisa B. Stabr is a freelance writer based in Palo Alto, California, and the author of Communications for the IBM PC and XT, forthcoming from PC World Books/Simon & Schuster.

(continued from page 110)

may be drawn. These operators can begin a new path or close the current path, and add straight line segments, circular arcs, and cubic curves to the current path.

- *Color, shading, and image operators.* PostScript programs have the ability to use different color models to specify color and halftone screens. These operators define the contents of specific areas for output.

- *Output operators.* After a path is constructed and the parameters such as colors, images, character fonts, and line widths are set, these operators define the limits of the output area and produce output on a printer device.

Drawing with PostScript

The high-level graphics output operators make it very easy to draw lines and arcs, and they let you rotate, duplicate, or fill areas conveniently. The short program "Bubble Graphics" draws a random bubble-like

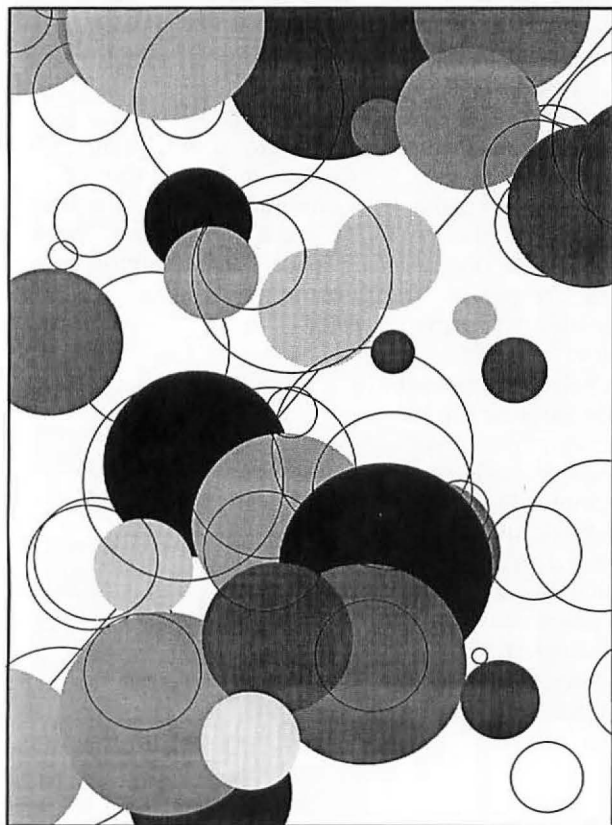

pattern on a page. The program was written on a VAX minicomputer and downloaded directly to the LaserWriter. PostScript allows you to write programs on any computer that generates ASCII text. You could even write PostScript programs on the Mac, using *MacTerminal* to communicate directly with a PostScript-equipped printer.

To create a procedure, you first quote its name, using the */* operator followed by the characters making up the name. You enclose the procedure in braces. With these two elements on the PostScript operand stack, executing the word **def** creates an entry in the dictionary that matches the *key*, or name of the procedure, with its *value*, the body of the procedure. Whenever the PostScript interpreter sees the key, it executes the associated procedure, which may be itself built from a sequence of keys or procedure definitions.

In the "Bubble Graphics" example, the word **circle** is defined to draw a circle with a radius and an *x-y* coordinate position taken from the top two elements of the stack. The definition depends on the word **arc**, which is a path construction operator that draws a counterclockwise arc with a given radius and a beginning and ending angle. The graphics output operator **stroke** tells PostScript that an independent section of a drawing is complete. PostScript then enters the section into a table of positions to be printed when the final output is ready.

Laser Bubbles

The abstract bubble designs were drawn by the "Bubble Graphics" program. The position, size, and color of each bubble were determined randomly and printed like a collage by the LaserWriter. Because PostScript treats information in terms of shapes and proportions, you could also produce randomly generated collections of perfectly formed characters.

```

/rot
{ 3 -1 roll
} def

/genRand % returns a random number between 0 and 1
{ rand % returns 0 < rand < 1
  100 mod
  100 div
} def

% returns a random (x,y) value on the page
/randPoint
{ 612 genRand mul
  792 genRand mul
} def

% makes the bubble pattern by randomly drawing circles
% throughout the page
/bubble
{ 0 0 moveto
  70 { placeCircle } repeat
} def

% draws a circle with the given radius at the (x,y) position
% ( radius, (x,y)-center )
/circle
{ rot
  0 360 arc

  genRand 0.5 gt % randomly decides whether
  [genRand setgray % to fill in the circle or not.
  fill
  0 setgray
] if

  stroke
} def

% place a circle somewhere on the page.
% It decides randomly how big the circle will be.
/placeCircle
{ 100 genRand mul
  randPoint circle

} def

0 0 moveto
bubble
showpage

```

Bubble Graphics

*This random bubble design program illustrates many of the important concepts behind PostScript programming. You precede a quoted name for an object with a slash, for example, **/rot**, the first procedure defined in this listing. Next create a procedure object by enclosing a sequence of commands in braces, and then associate the quoted name with the procedure object by executing **def**. Once the procedure has been defined, it can be used in the same context as any of the operators in the language.*

*Important operators in this example are defined as follows: **moveto** instructs the PostScript pen to move to an x-y position on the page; **arc** gives the instructions to draw a complete circle; **setgray** determines how much gray to give a circle; and **stroke** tells PostScript that a complete shape description has been entered. The % character is used to begin a comment and tells the interpreter to ignore information that follows on that line.*

Logo Rotate

Two important procedures in the program rotate the Times Roman characters shown in the "Laser Logo" figure. The main procedure, **logorot**, is actually built out of other procedures defined previously. The lesser procedures, **logosetup** and **rotationloop**, are called by **logorot** to perform the actual rotation. Note how **rotangle**, **rotoffset**, and **graylevel** are used the way variables are in most other languages; their quoted names are associated with numbers instead of procedure objects enclosed in braces. The values are changed during the **rotationloop** procedure as the program adjusts the font characteristics during each loop. The rotation of the characters is done by the PostScript operator **rotate**, which rotates the entire page by the angle given at the top of the stack.

```

/Q (7.2 mul) def

/rotangle 90 def
/rotoffset 22.5 def
/graylevel .9 def

/logosetup
  {(Times-BoldItalic) findfont
   [110 0 0 110 0 0] makefont setfont
  } def

/point (0 0 moveto) def           % start point for show

/rotationloop
  {gsave
   point
   rotangle rotate % rotate the whole page by rotangle
   graylevel setgray
   (Rosebud) show

   /rotangle rotangle           % change the rotation angle
   rotoffset sub def           % for the next time through
   % the loop

   /graylevel graylevel       % make it a little darker
   .15 sub def                 % next time
   grestore) def

/logorot
  {gsave
   20 Q 30 Q translate % move user origin to (20,30)
   logosetup

   0.75 0.75 scale % scale everything a little smaller

   5 {rotationloop} repeat

   grestore) def

logorot
showpage

```



Other operators like **rand**, which generates a random number, and **fill**, which fills the contents of a closed section, complete the definition of the procedures. The procedures can then be interactively executed. To send the drawing to the printer, you use the **moveto** path construction operator to give coordinates to PostScript. Then you run the "Bubble Graphics" program, and finally you use the **showpage** graphics output operator to finish the page and eject it from the printer. The output from one run of "Bubble Graphics" is shown in the figure "Laser Bubbles."

Another short program, "Logo Rotate," uses PostScript's text design operators. The figure "Laser Logo" shows the output of the program. The main procedure, **logorot**, is built from calls to other procedures defined previously. The procedure first calls **logosetup**, which initializes the font to be Times Roman bold italic and changes the characteristics of the font to fit correctly on the page. The **repeat** command calls another procedure, **rotationloop**, five times to produce the fanning effect of the logo rotation. In the **rotationloop** procedure the PostScript operator **rotate** tells the printer to rotate the page by the angle stored in the variable, **rotangle**. The amount of shading is stored in the variable **graylevel** and is set by the **setgray** operator before the words are "imaged" by the **show** command. Then the variables are decremented to show the values they will hold the next time through the loop.

These simple examples show the potential for printing text and graphics with a PostScript-equipped computer. Unfortunately, Adobe has no immediate plans to market PostScript as a consumer programming language to compete with Pascal, BASIC, and FORTH, so Mac owners may not have the opportunity to discover the extent of the power built into Apple's LaserWriter. □

◆◆◆◆◆◆◆◆◆◆ *Richard Sprague is a freelance writer and programmer who studies formal linguistics at Stanford University. He also works at Stanford's Center for the Study of Language and Information.*

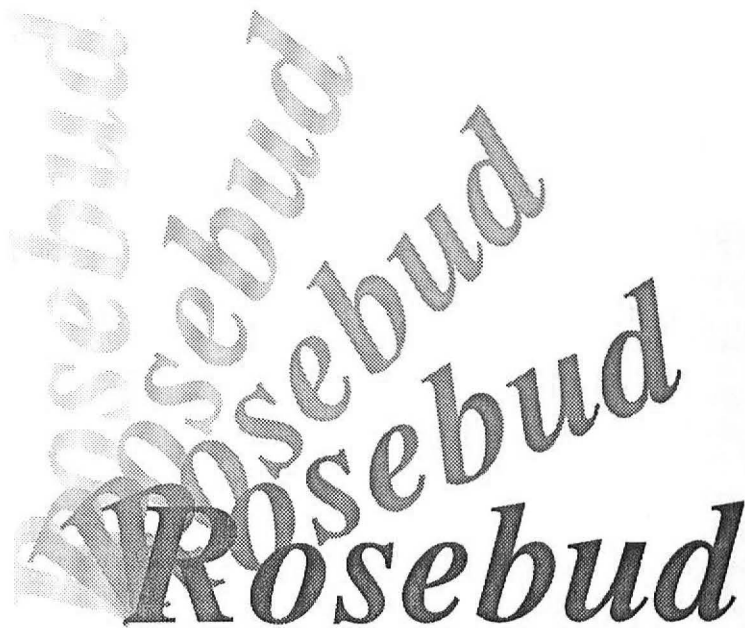
◆◆◆◆◆◆◆◆◆◆
*PostScript
Adobe Systems Incorporated
1870 Embarcadero Rd. #100
Palo Alto, CA 94303
415/852-0271*



Laser Logo

All the characters in this rotating sequence are perfectly formed Times Roman font, set at the angle appropriate for the rotation but which retain the essential features of the font. Test versions had slightly different sizes and angles of rotation. This kind of trial-and-error testing can be done in a few minutes with PostScript. Such testing might take a professional typesetter an afternoon or more.

MUSICWORKS™ BRINGS OUT THE MUSIC IN YOU.

WRITE THAT TOP 40 HIT YOU'VE ALWAYS DREAMED OF.

With MusicWorks you can compose music directly on your Macintosh™ and hear the results instantly.

Even if you can't read a note, you can easily use MusicWorks to produce professional musical scores. You compose on a seven-and-a-half octave grid that corresponds to the keys of a piano. Use your mouse to place "notes" on the grid. As you place them, you hear them. When you've got your song the way you want it, MusicWorks can transform your grid into a musical staff, insert the proper musical notation, and print it out in a professional format which any musician can follow.

If you already know musical notation, you can compose directly on a staff. Use the mouse to place your notes, to select the meter and key signatures, and to listen to your music instantly.

Either way, grid or staff, if you make a mistake or want to change something, simply erase and edit.

You can play back your whole

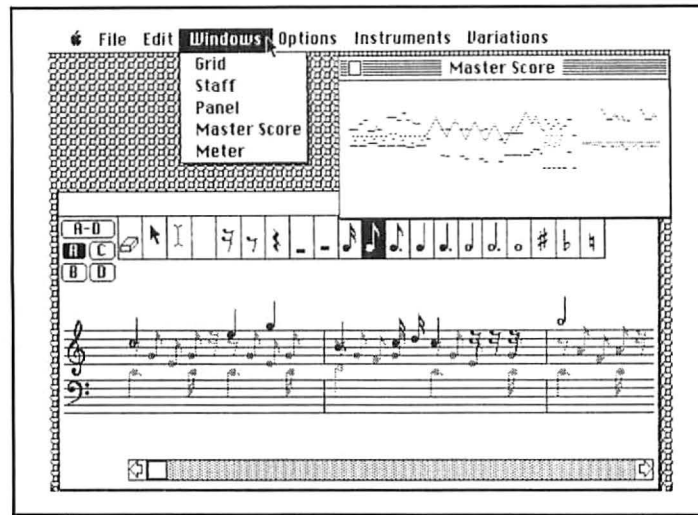

composition or any part of it whenever you want.

ORCHESTRATE 4 PARTS SIMULTANEOUSLY.

Choose any 4 instruments from out of a selection of 10. You've got piano, chimes, flute, trumpet, organ, even a synthesizer for that contemporary electronic sound.

You can hear all four instruments at once, or turn them off selectively so you can alter individual parts.

A LITTLE BACH IN EVERY BOX.

MusicWorks comes with templates which guide you through the instructional process

by playing classical and popular selections.

MusicWorks is part of the Hayden HeadStart Program which allows schools to accumulate points toward free computers, peripherals, and software. Buy MusicWorks, and your school will receive 50 HeadStart Points.

MusicWorks. Only \$79.95. Contact your local computer software dealer or Hayden Software, 600 Suffolk Street, Lowell, MA 01854, phone toll-free 800-343-1218.

Macintosh is a trademark of Apple Computer Corporation. MusicWorks is a trademark of MacroMind, as licensed exclusively by Hayden Software Company, Inc.

*HAYDEN.
AMERICA'S FIRST FAMILY
OF SOFTWARE.*

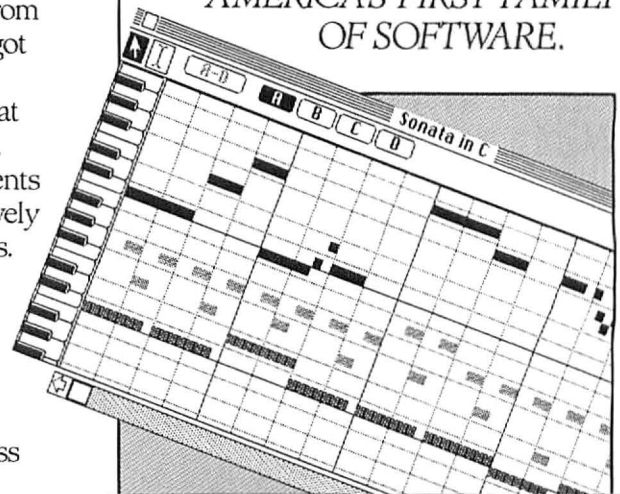

HAYDEN

PIT YOUR PLUCK AND WIT AGAINST THE FORCES OF EVIL IN THE MYSTICAL GAME OF THE HOLY GRAIL.

IT GETS BETTER WITH TIME.

For centuries, valiant knights have pursued in vain the fabled Holy Grail.

Thank the fates, oh brave adventurer, that you come better equipped in your search than the many who went before you. They had naught but the brute force of sword and lance. You have something far, far mightier, the awesome power of your Macintosh™ and the wondrous game of The Holy Grail. With those two at your beckoning, you can journey through the medieval countryside; do battle with bold knights and foul dragons; converse with kings, thieves, and clerics; rescue a fair princess; and pursue a treasure which has eluded mankind for ages.

ACT QUICKLY. THIS GAME WILL NOT BE THE SAME AFTER YOU TURN THE PAGE.

The Holy Grail is one of Hayden's innovative new

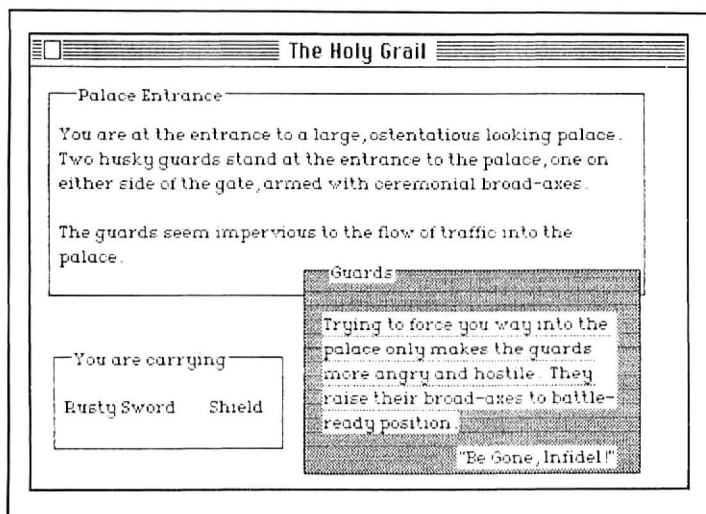

TimeQuest™ Adventure games. In these games of interactive fiction, the passage of time plays an active and crucial role. The whole nature of the game changes instantly, before your very eyes. If you aren't wise enough or swift enough to take advantage of circumstances, you may forever alter the course of your future.

So come! Through the ages, countless others have tried and failed. Now it's your turn. Take up the quest. Succeed, and you catch a glimpse of immortality.

But be wary! Myriad pitfalls lurk. You will need extreme

cunning if you are to evade the treacherously clever villainy you will encounter along the way.

If you be the least bit faint of heart, try some other game instead. For dangerous adventures aplenty await you in your bold attempt to unravel the age-old secret of The Holy Grail.

The Holy Grail. Only \$49.95. See your local software dealer, or contact Hayden Software, 600 Suffolk Street, Lowell, MA 01854, phone toll-free 800-343-1218.

Macintosh is a trademark of Apple Computer Corporation. TimeQuest is a registered trademark of Hayden Software Company, Inc.

HAYDEN.
**AMERICA'S FIRST FAMILY
OF SOFTWARE.**

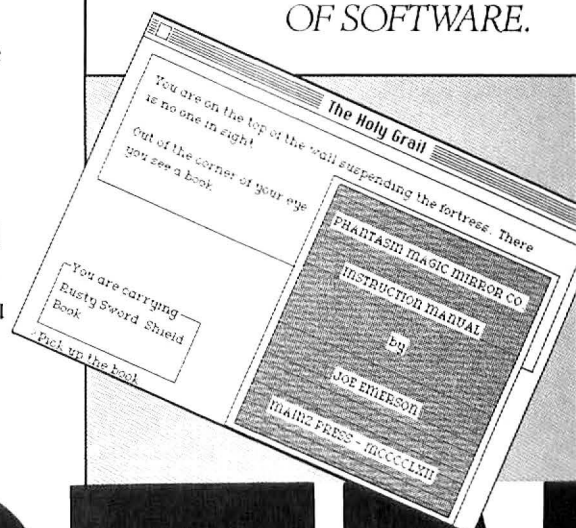

HAYDEN

HAYDEN:BASE™

FORM A BETTER RELATIONSHIP WITH YOUR DATA.

SENSATIONAL RELATIONAL!

Hayden:Base is a fully relational database management program designed for the Macintosh.™

It organizes your data, interrelates it and then lets you look at it from multiple points of view.

There's no end to the way Hayden:Base can manipulate and interpret your data. Base fields can contain single or multiple entries. Fields are of variable length and can contain alpha or numeric data, dates, times, even MacPaint™-created illustrations!

AN EASY WAY TO KEEP TRACK OF WHO, WHAT, WHERE, WHEN AND WHY.

Hayden:Base is so simple and elegant to use that you can perform the majority

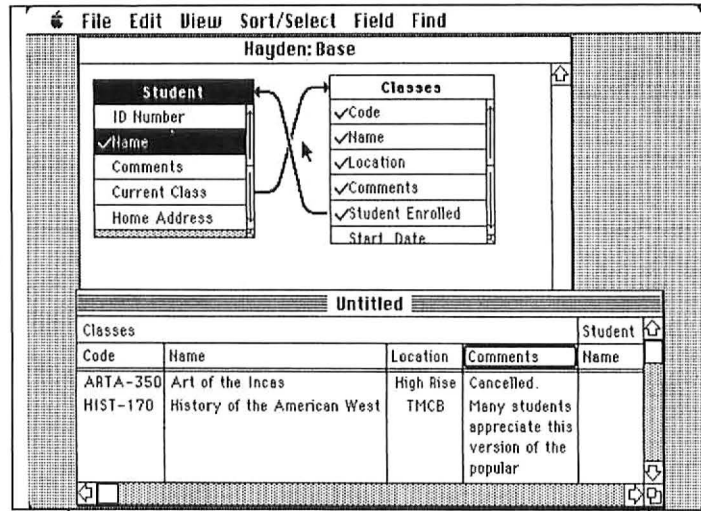

of your analyses without ever touching the keyboard. You manipulate your data using your pointer and pull down menus. Overlapping windows let you look at several files simultaneously.

Hayden:Base lets you easily prepare reports or custom design forms.

If you change information in one file, Hayden:Base automatically updates information in up to 15 other related files.

BASE YOUR DATA ON HAYDEN:BASE.

For information about this innovative productivity tool, contact your local computer software dealer or Hayden Software, 600 Suffolk Street, Lowell, MA 01854, phone toll-free 800-343-1218.

Macintosh and MacPaint are registered trademarks of Apple Computer Corporation.

Hayden:Base is a registered trademark of Hayden Software, Inc.

HAYDEN. AMERICA'S FIRST FAMILY OF SOFTWARE.

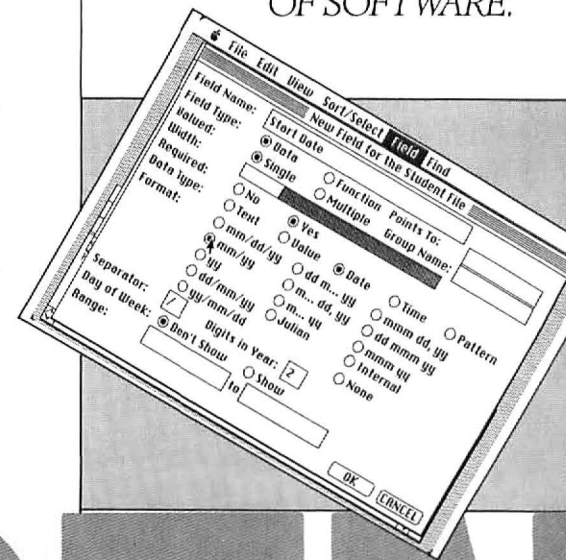

HAYDEN

HAYDEN:SPELLER.™ MAKES MACINTOSH™ LETTER PERFECT.

TAKE THE FICTION OUT OF YOUR DICTION.

The Hayden:Speller spelling checker software program catches and corrects spelling errors and typos.

It's easy. Using pulldown menus and dialog boxes, you check your documents against a dictionary covering 97% of the most frequently used words in the English language. It's quick. Hayden:Speller can check a 5 page document in less than 10 seconds. It's complete. You can easily create your own "personal dictionary" with up to 50,000 words per disk. You can then let Hayden:Speller check these words, too.

EASY, FAST, AND SIMPLE.

Hayden:Speller either lists questionable words or points them out in context. You choose what to do next.

If the word's correct as is, let it go unchanged. If it's an

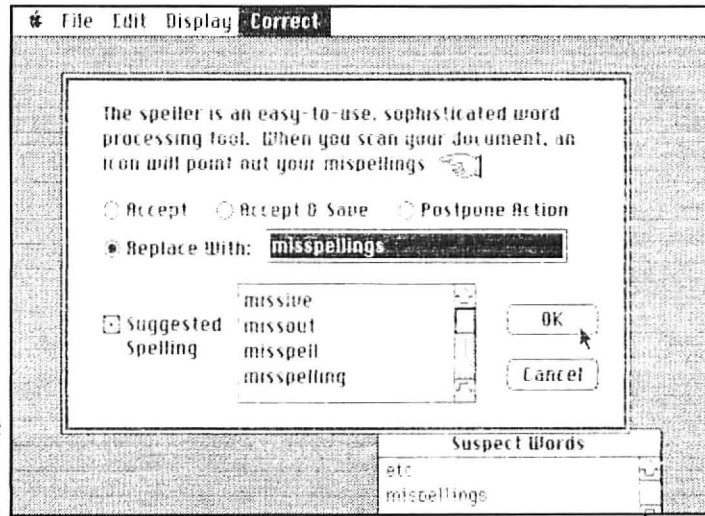

obvious misspelling, change it yourself. You can do it directly within the spelling checker program. There's no need to switch back to your word processing disk. If you don't know the correct spelling, have Hayden:Speller find it for you.

A click of your mouse makes the necessary correction.

WORKS WITH MACWRITE™ AND MICROSOFT WORD™

Hayden:Speller is fully compatible with MacWrite and Microsoft Word. It takes

advantage of their special Macintosh features, such as windows, menus, and of course, mice.

For more information on Hayden:Speller, contact your local computer software dealer or Hayden Software, 600 Suffolk Street, Lowell, MA 01854, phone toll-free 800-343-1218.

Macintosh and MacWrite are registered trademarks of Apple Computer Corporation.
Hayden:Speller is a registered trademark of Hayden Software, Inc.
Microsoft Word is a registered trademark of Microsoft Corporation.

*HAYDEN.
AMERICA'S FIRST FAMILY
OF SOFTWARE.*

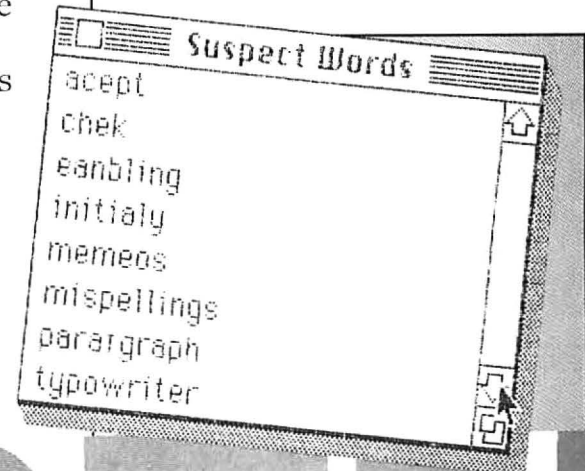

HAYDEN

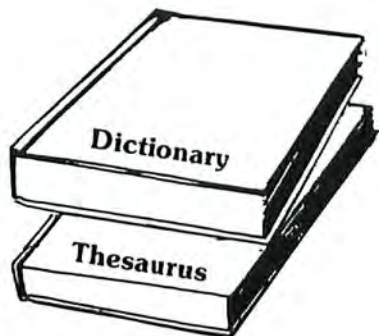

MacSpell+™

Interactive Spelling Checker For Your Macintosh™ with Thesaurus and Word Hyphenation

As easy to use as it is **POWERFUL**, **MacSpell+** provides you with three tools you will need to compose documents with confidence and flair!!

+ Spelling Checker: **MacSpell+** is an interactive spelling checker — YOU DO NOT HAVE TO QUIT THE WORD PROCESSING PROGRAM IN ORDER TO PROOF YOUR DOCUMENT! As a result, you save time and effort. **MacSpell+** contains over 30,000 words in its dictionary and provision for you to add over 2,500 words of your own . . . and all with a click of the mouse;

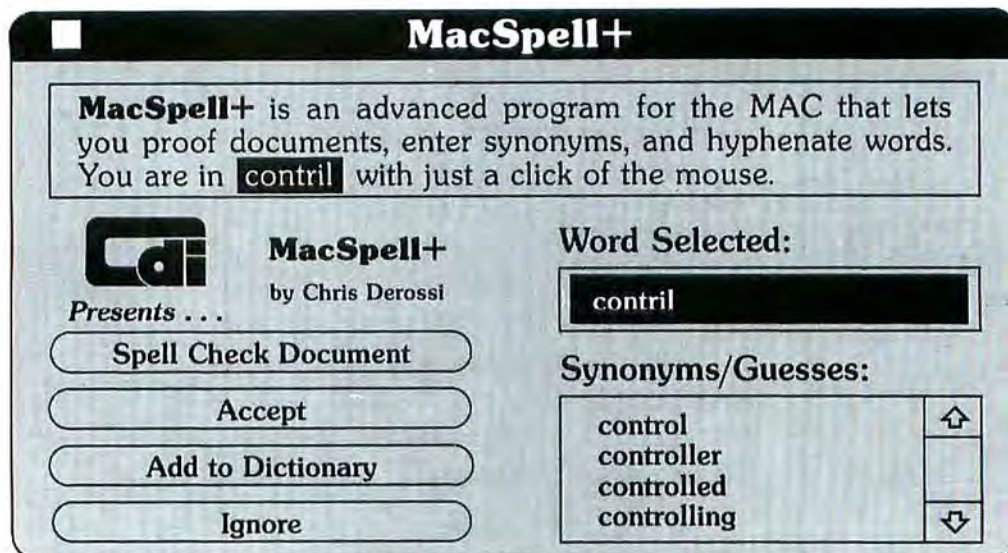

Choose one of the **MacSpell+** suggestions or type in your own spelling. You may also add the word to your dictionary. It is EASY AND CONVENIENT.

+ Thesaurus: **MacSpell+** contains a convenient thesaurus to enable you to select a synonym at a click of the mouse. Merely "select" a word from your text and a list of synonyms will appear. Click your choice and it instantly replaces the word you selected from your text. Again, the thesaurus is interactive and you never have to quit your word processor.

+ Word Hyphenation: **MacSpell+** also contains an interactive word hyphenation feature which enables you to select the proper word hyphenation points by clicking the mouse. The hyphenated word is then automatically inserted into your text.

MacSpell+ will improve your efficiency and streamline your word processing function with only a click of the mouse!! only \$99⁰⁰

ORDER TODAY OR SEE YOUR DEALER!!

Creighton Development, Inc. 4931 Birch Street, Newport Beach, CA 92660
(714) 476-1973



TM—MacSpell+ is a trademark of Creighton Development, Inc. Macintosh is a trademark licensed to Apple Computer, Inc.

Circle 95 on reader service card

CUT TO THE CORE QUICKER WITH MAC-BARCODE.

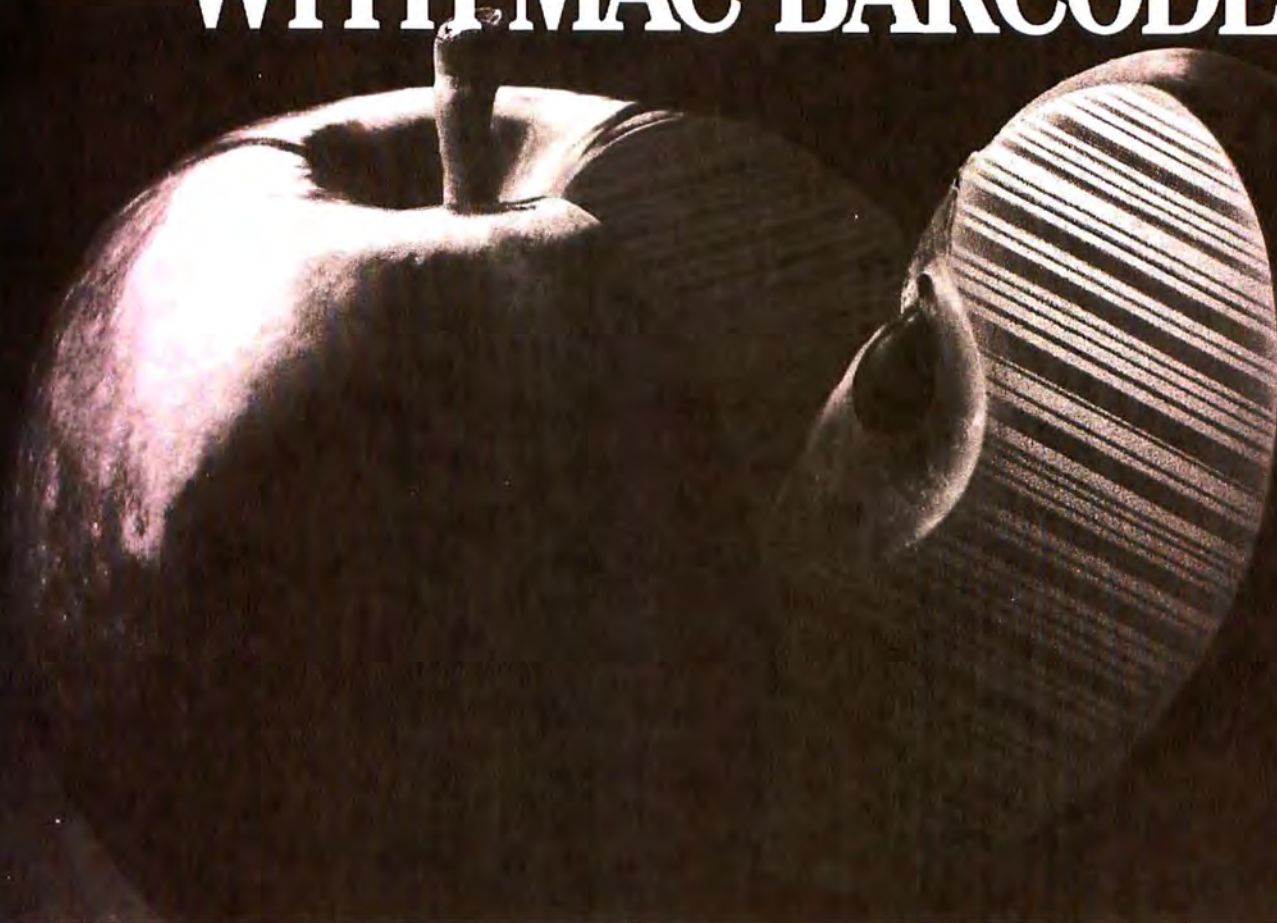

Introducing Mac-Barcode.™ Label-generating software for the Apple® Macintosh.™

In minutes, you can transform an Apple Macintosh into a complete, low-cost bar code workstation. With Mac-Barcode, a new label-generating software

package from Computer Identics.

It generates bar code labels and documents, according to specification and style, that meet the requirements of a number of industries: automotive, health care, food processing and packaging, as well as the U.S. Department of Defense's LOGMARS program. Labels and documents can be produced on-the-spot using Apple's Imagewriter printer.

Mac-Barcode puts you in touch with the unsurpassed benefits of bar code data entry: speed, accuracy and reliability. A technology that

is three million times more reliable than keyboard data entry and 300 times more reliable than Optical Character Recognition (OCR).

When used with the SCANSTAR-Mac, a CI scan/decoding unit, Mac-Barcode offers an easier, more efficient means of monitoring inventory control, filing, work-in-process tracking, point-of-sale operations, security, and training. The immediate result: you have complete control over on-site printing of labels and documents that integrate text, graphics and coded information.

Additional features of the Mac-Barcode program include the use of the familiar "mouse," ICONS, and pull-down menus that make the Macintosh so easy to use.

Twelve years of CI bar code technology have been integrated into Mac-Barcode. This technology puts more bite into your Macintosh.

For more information, call our toll-free number today—1-800-MAC-CODE.



**computer
identics**

The Bar Code Company

5 Shawmut Road, Canton, MA 02021
Tel. (617) 821-0830 · TWX 710-348-0828

Apple and the Apple logo are registered trademarks of Apple Computer, Inc. Macintosh is a trademark licensed to Apple Computer, Inc.

Circle 89 on reader service card

The Elements of Graphic Design

Edited by Bill Grout

For the many people who are bashful about their drawing skills, the Macintosh is a small miracle, coaxing art out of uncertain hands and reluctant hearts. Fascinated by programs like MacPaint and MacDraw, nonartists are being enticed into producing designs and illustrations. If you're one of the hesitant many, however, you might feel uncomfortable about producing artwork. You know there's more to it than holding a gaging thumb up to the screen, but you're not sure how to start.

To help overcome your hesitation, Marjorie Spiegelman, the designer of *Macworld* and *PC World* magazines, offers some guidelines for creating graphic designs with the Mac. A designer for 14 years, Spiegelman has taught design at the University of California at Berkeley.

If you're unfamiliar with graphic design, you might puzzle over what to include in your designs. Real-life objects and information may present an overwhelming number of details. Not knowing where to start can easily block the design process. Instead of waiting for inspiration, start by analyzing the information that must be presented. Such an analysis of content will usually suggest a form, or design. According to Spiegelman, the cardinal rule, "Organize it and keep it simple," should be stamped on the hands of all artists.

"One common misconception about design," says Spiegelman, "is that you take all the pieces and push them around until they look good to you. Design isn't quite so random. Real design requires analyzing and organizing the graphic structure of the information presented.

"Think about which information is the most important," Spiegelman suggests. "Right away you have quite a few clues as to how big objects ought to be and which elements should be prominent in the picture. Often, more important elements are bigger or get placed at the top of a page. You can find other clues about size, too. If your illustrations are going to be printed in a 6-inch-wide format, for example, you already know their upper size limit."





Figure 1 shows an illustration that's a casualty of poor planning. Figure 2 shows how the illustration is improved with a more understandable organization.

Another consideration is how an illustration is to be reproduced. Many people using the Macintosh to create designs will probably have their illustrations "quick printed" or reproduced on a copier. "With those methods of reproduction," says Spiegelman, "you have to think about density of pattern, size of type, and whether details will show up when reproduced. With copying machines, reproduced illustrations end up with less detail than the original art. Fine detail is lost, thin lines drop out, typeface patterns close up."

Spiegelman emphasizes that reducing designs on a copying machine can dramatically decrease their legibility. If you plan to reduce a design, keep in mind that fine detail may suffer; use thick lines and select large, easy-to-read fonts.

Strike a Tense Balance

Good design demands more than a sense of "engineering." Designs must be balanced, composed so that they entice a viewer's eye and provide information in an easily understandable way. The placement of elements in a good design is not accidental. Placement should be planned to establish an interaction or tension among the elements that provides visual intrigue. Too many elements, or groups of similar elements, should not be present, nor should any one element completely overpower another.

In setting up the interaction among elements, don't ignore the background or white space in the composition. While too little background space makes for an overcrowded, hard-to-read design, too much background space can overpower the information, resulting in a static composition that is uninteresting to the eye. A good design has balance: opposing forces or tensions entice the viewer while reinforcing the relationships among the elements, including the background.

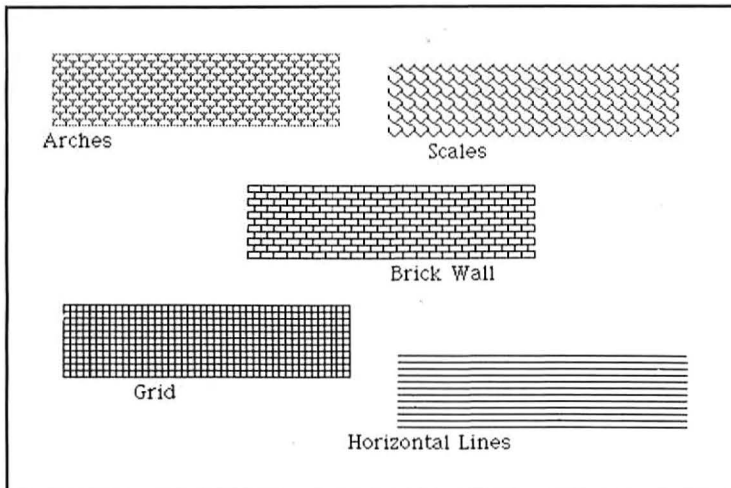

Figure 1
The rectangular patterns are misaligned and the labels placed in various positions beneath each pattern. The placement causes the reader's eye to move erratically across the page to gather information.

A natural tendency for beginning designers is to center the elements of a composition or to make everything the same size, weight, or color. The resulting lack of contrast is rarely an advantage in conveying information. Contrast and asymmetry can be very effective for making a design dynamic. "A very interesting composition," notes Spiegelman, "is one with a large, heavy element at the top [see Figure 3], that suggests a potential energy to the viewer." Figure 4 shows a design that suffers from a lack of contrast.

Suppose you begin an abstract design by placing a huge circle at the top of the composition. A small dot, properly sized and positioned below the circle interacts with the circle and balances its potential energy. The dot also interacts with the edges of the composition, reinforcing its own energy while at the same time working to activate the surrounding white space. You could also add a line to reinforce the relationship between the circle and the dot. In this design every element—the circle, the dot, the line, and the white space—takes part in the overall dynamic of the composition. The relationships of the forces or tensions among all the elements are such that no single element overpowers another. In other words, the design is balanced.

A simple way to check the balance of elements in a design is to turn it upside down. "By viewing a design upside down, you may see that the picture overall

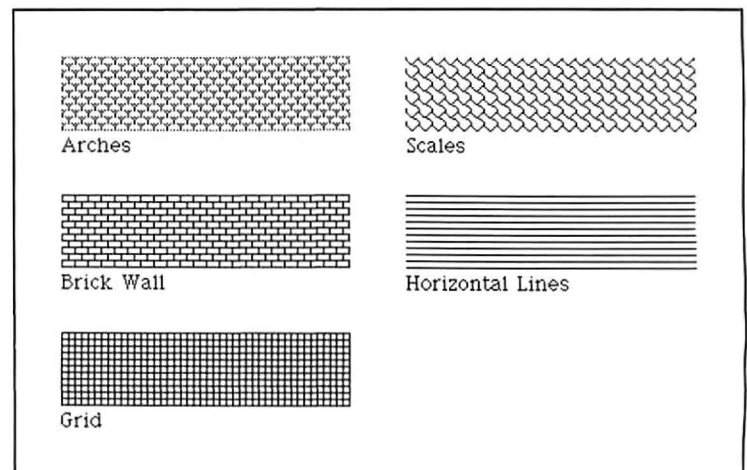

Figure 2
In this design the rectangular patterns are aligned both vertically and horizontally, and labels are placed in the same location beneath each pattern. The reader easily sees the organization and can pick out desired information.

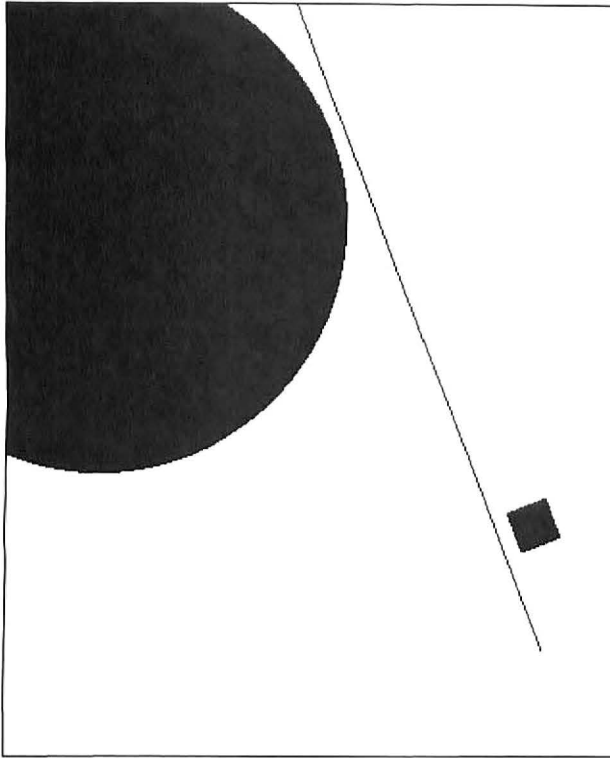

Figure 3
The viewer's interest is piqued by this design, which shows objects seemingly about to collide. Notice how the small square balances the large partial circle yet holds the viewer's interest

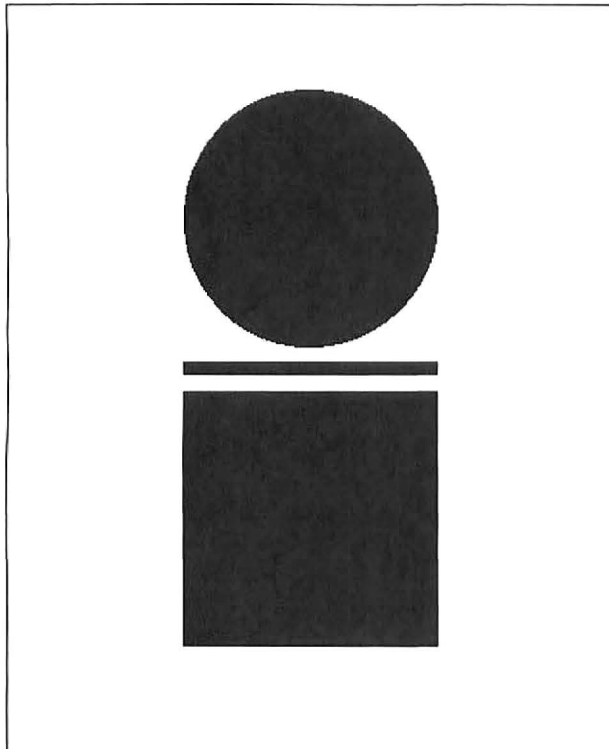

Figure 4
This design uses common shapes, all in black, stacked symmetrically. None of the three shapes stands out by itself in this stable and uncontrasted arrangement.

presents a lopsided impression or that it contains too many elements. Go with what looks good to your eye. Some designs I've turned upside down and left that way," laughs Spiegelman.

Avoid Visual Competition

Macintosh graphics can tempt budding artists toward a flamboyance that results in confusion. Misapplied special effects in programs like *MacPaint* sometimes result in visual elements of unequal importance competing for attention. Flashy outlined fonts, for instance, may draw attention away from important aspects of a design.

To avoid confusion, Spiegelman recommends organizing the information according to levels of importance. Once you determine the levels, begin creating the design by assigning visual signals to each level. Three main visual signals can be used: color, size or weight, and placement on the page. For instance, the most important information might be positioned at the top of the page and appear in color in the largest typeface.

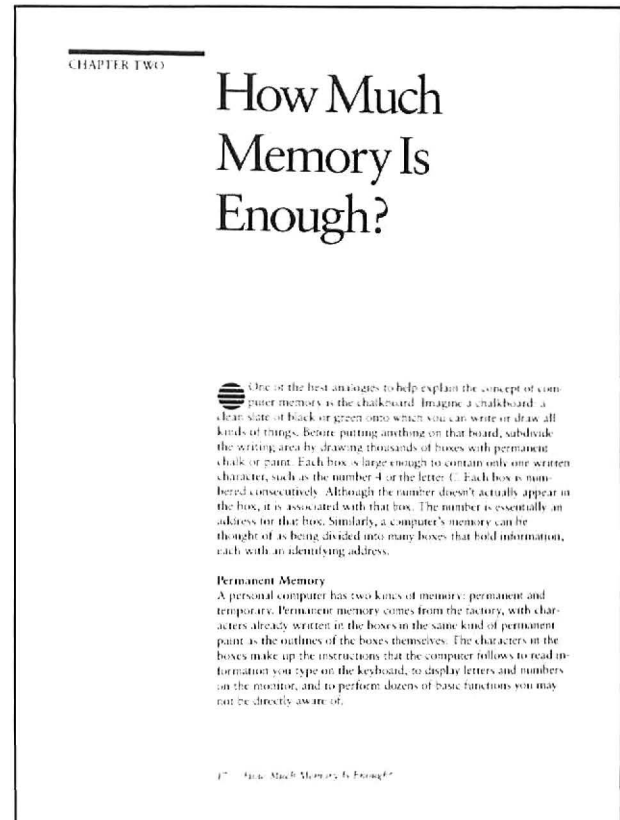

Figure 5
The large chapter title at the top of the page and the presentation of paragraphs with subheads provide a clear organization. Notice how the broken circle allows the reader to spot quickly the beginning paragraph.

Creating Likable Labels

MacPaint has greatly increased the ease with which you can label graphics. No longer do clumsy "nonartists" have to worry about aligning fragile transfer letters neatly on paper. *MacPaint* provides a good selection of typefaces and sizes for labeling illustrations, and the erasable screen quickly forgives mistakes. But you should avoid arbitrarily planting labels around a picture.

The labels in a graphic design should be planned, not hastily added after the artwork is done. The organization should be as consistent as possible. If you can place all the labels for a diagram in one accessible area—aligned flush left of the artwork, for example—you create a constant starting point for reading each label. The viewer doesn't have to search all over the diagram to find the necessary information.

In addition, the diagram's caption can be aligned flush left with the labels. Placing the caption on the same vertical axis as the labels increases the clarity of the information, making the viewer's job easier.

A plain old fat typeface reproduces better than some of the fancy outlined fonts. Many people use all capital letters more often than they should. Alphabets aren't designed to be used with all capitals. The best legibility is achieved with initial capital letters and lower-case. Unlike book titles or newspaper headlines, in which

all important words are capitalized, labels are easier to read when only the first letter of the first word is capitalized. Capitalizing every word creates an uneven texture and decreases legibility.

Another mistake is spreading words out across the page by putting extra space between letters. Such spacing makes the words difficult to read. Labels should not be placed too close to the artwork, and the letters in a label should not run over actual art lines (see the figure

"Labels and Lines"). Visual competition between lines and labels destroys the shape of the letters and detracts from legibility.

It's a good idea to use only one typeface for all the labels in a design, since a hodgepodge of different fonts and sizes makes a design look disorganized. Using the same labeling method consistently within a design, as well as in a series of related designs, can add to a sense of unity and ease of access. Arbitrary changes in type style can be confusing.

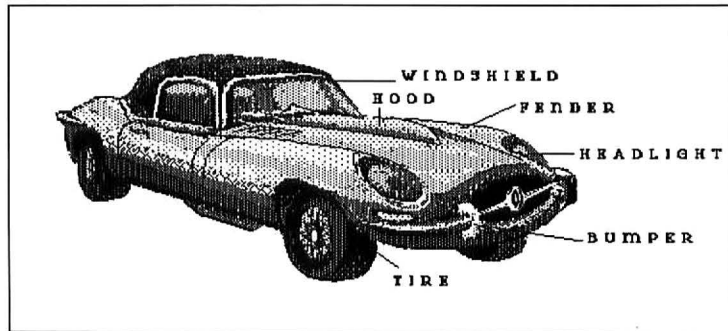

Labels and Lines

The labels in this design compete for attention with the image of the car. All the letters are capitalized, making the labels more difficult to read than if only the initial letters were capitalized.

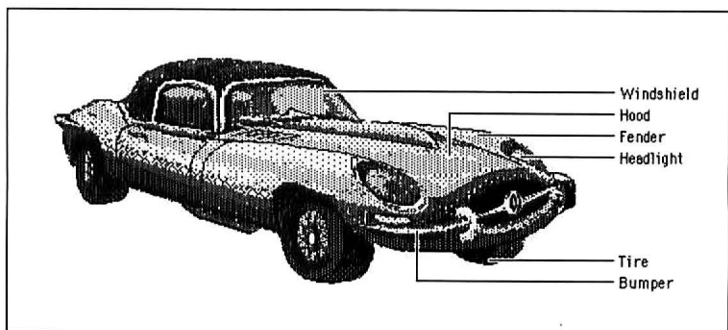

Labels and Leaders

The clear organization of labels does not detract from or compete with the car's image. The leaders are used consistently and begin at the same position relative to each label.



When labeling a design, you must also be careful with leaders, those lines that extend from a label to a corresponding part of an illustration, connecting verbal and visual information. Since it's tempting to send lines in rubber-band stretches across the Macintosh screen, leaders can easily be misapplied so that they detract from a design's visual effectiveness. Leaders should be consistent in width and placement. In other words, they should appear to have the same thickness: while they may be horizontal, vertical, or angled, they should be consistent within a design.

Be careful with those leaders that travel across the page at an angle. Ideally, angled leaders should be drawn at the same angle (the easiest one to draw on the Mac is a 45-degree angle). Also, be aware that an angled line will seem thicker than a vertical or horizontal line because of the "staircase" effect of certain Mac graphics. If you have to combine angled leaders with horizontal or vertical leaders in one diagram, draw an angled leader first, then draw horizontal or vertical leaders to look like the angled one. That way all the leaders will match, helping to convert information easily for the viewer. The figure "Labels and Leaders" shows how the design in "Labels and Lines" is improved with the consistent use of labels and leaders.

A clear application of visual signals occurs on the opening page of a book chapter (see Figure 5). Book chapters are organized into chapter titles, introductions, text headings, and text. These different kinds of information are assigned visual signals which show their importance. Usually the chapter number and title are the biggest and are placed at the top of the page. Introductory text may be in a different type style, and the text headings and text may be printed in similar type styles, with headings bolder than the text. Each type size or style as well as each position on the page is a visual signal. Figure 6 shows the same principles applied to a nonverbal design.

State It with Empty Space

A 1-inch square on typing paper may be a small rectangle to the mind, but to the eye it may seem to be a box floating on a lonely universe of white. The background of a design is an element to consider. You create a design when you put a dot on a piece of paper. Relationships exist between the dot and the edges of the paper, and you can't ignore them. You have to ask yourself if the relationships are correct: have you left so much white space around your design that it's lost on the paper? Have you left so little space that the design isn't set apart from nearby text?

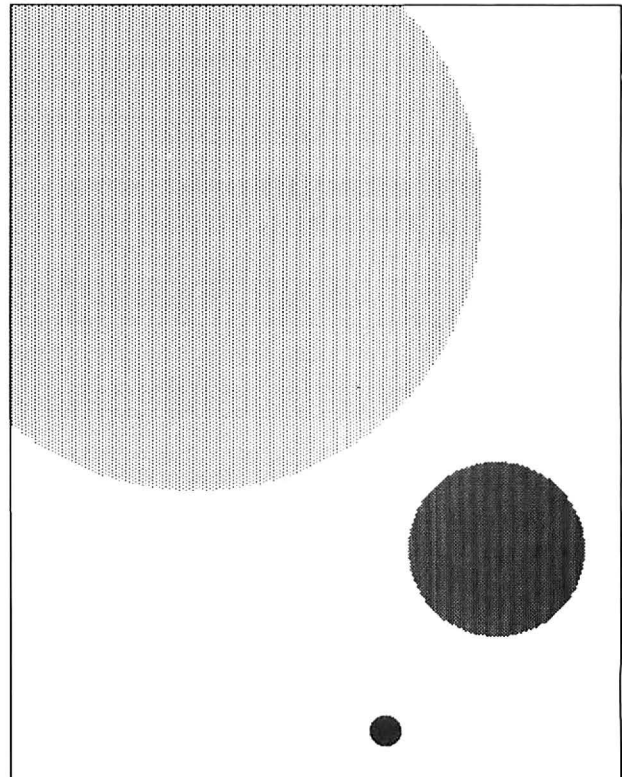

Figure 6

The circles in this design are ordered visually according to their size and shading. The viewer's eye moves from the small black circle to the middle-size circle and finally to the larger, light gray circle.

Appropriate spacing between elements in a design is as important as proper space around the design as a whole. One method the eye uses to gather information is to group things by proximity. A small space between elements in a design can imply a relationship between the elements, while a large space between them can be used to signal a break. Spacing is particularly important in designing charts and tables, where information must be distinguished easily. A viewer may be confused by unrelated graphic elements or pieces of verbal information placed too close to one another. Figure 7 shows an example of inappropriate spacing. The organization of information that should be read horizontally appears confusing because of the vertical placement of lines. The problem can easily be resolved by placing more white space between lines and horizontally tightening them as shown in Figure 8.

Catch an Eye

Metaphorically speaking, each design should have a tiger's eye, burning bright—a point that you see immediately. Says Spiegelman, "You need to create a focal point, where the viewer can start looking at the image. The focal point doesn't have to be anywhere in particular." An illustration about a specific key on the Mac keyboard might have the entire keyboard shaded in gray with the key in question shown in color or solid black. The emphasized key is the focal point. Figure 9 shows a design lacking a focal point. Notice how the problem is resolved in Figure 10.

Printing Features	ProPrint	LetterWare
Underlining	Yes	Yes
Boldface	Yes	Yes
Subscripts	Yes	Yes
Spacing	Yes	No

Figure 7
The information in this table is spaced inappropriately. Since the table is meant to be read horizontally, the reader will have difficulty because the design gives a strong impression of vertical columns.

You can create a focal point by assigning a visual element a prominent size or position. "Place the important image where it can easily be seen, and make sure the background isn't cluttered with competing visual signals," explains Spiegelman. The focal point should have at least one visual signal that will not be used with any other elements. For instance, even when all the elements have to be the same size, the focal point can have a different color or pattern. When possible, you might further emphasize the focal point by giving it one or two more visual signals: position it in a different place on the page or make it a different size.

Scale or size changes are a useful way of creating a focal point. Given a number of bar graphs on a page, for example, you might make one of the graphs three times larger than the others. Try to arrange the page with one large graph and three graphs in the same smaller size. This way you set up a contrast between two sizes, instead of four. You also simplify the design by composing a page with two main groups of visual elements. Another advantage is that each of these groups contains an odd number of elements (one and three), which is more visually interesting than an even number of elements.

Bring Out the Important Facts

Contrast is important to the impact a design has on the viewer. It can be created in several ways, but most often by varying size, color, and position. With its variety of brush types and patterns, *MacPaint* offers simple methods of creating contrast. You must develop an eye, however, for effective contrast. "You need contrast to set information apart," says Spiegelman. "Yet too much contrast may cause images to overpower one another. You have to develop a sensitivity. You have to look, because there's no practical way to apply

Printing Features	ProPrint	LetterWare
Underlining	Yes	Yes
Boldface	Yes	Yes
Subscripts	Yes	Yes
Spacing	Yes	No

Figure 8
Information in this design is easy to decipher because the horizontal spacing of the information has been emphasized. The reader can easily look across the table to find information.

mathematical concepts or steadfast formulas to contrast." Figure 11 shows how contrast can be used to bring out important facts. Figure 12 shows how too much contrast can detract from a design.

Legibility is a major concern of designers who need to communicate specific information. Contrasting shades and patterns in a design should serve the intent to communicate, improving legibility. But how much contrast is too much?

Spiegelman replies that the amount of contrast to use depends on "the structure of the design itself and the context in which it will be viewed; for example, whether it's an illustration in a book or a poster on the

wall. If you want to make a design look good, you have to do what every designer does: learn how to see. You must step back from what you are creating and look at the design as well as its context."

Between Doodles and Degas

If your design skills fall somewhere beyond doodles and short of Degas, you may soon attempt artwork on the Macintosh that you wouldn't have tried with paper and pencil. Spiegelman's guidelines for organizing information, creating focal points, maintaining spatial continuity, and using contrast effectively are important to recall as you work. Whether you intend to create first-class designs for yourself or rough sketches for a graphic arts department, your Macintosh can help you communicate visual information effectively. □

Bill Groat is a columnist for the San Francisco Chronicle, author of MultiMate and More! (Addison-Wesley), and coauthor of Symphony for Your Business (Hayden Book Company).

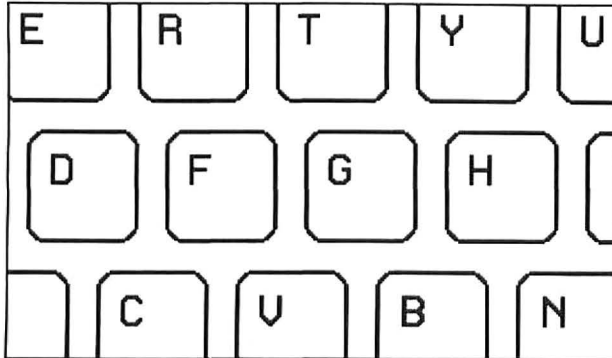

Figure 9
Because the keys in this design do not stand out from one another, the reader's eye is not drawn to any one

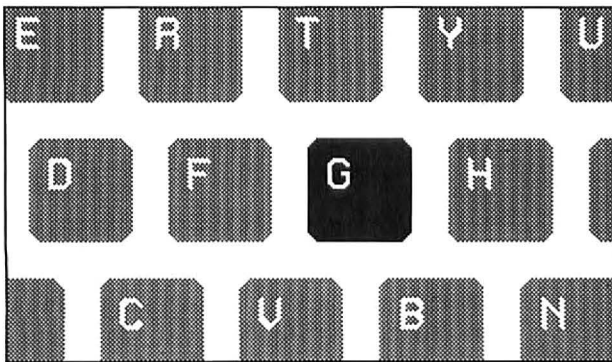

Figure 10
The G key is the focus of this design and stands out because of contrasting shading. The viewer can easily pick out the key being emphasized.

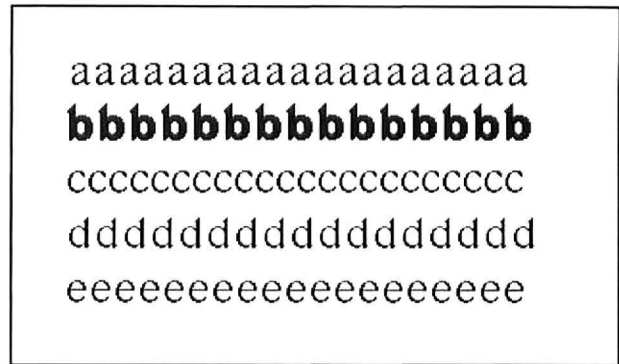

Figure 11
The row of bold letters in this design contrasts with the other rows. The reader senses that more importance is placed on this row of letters than on the others.

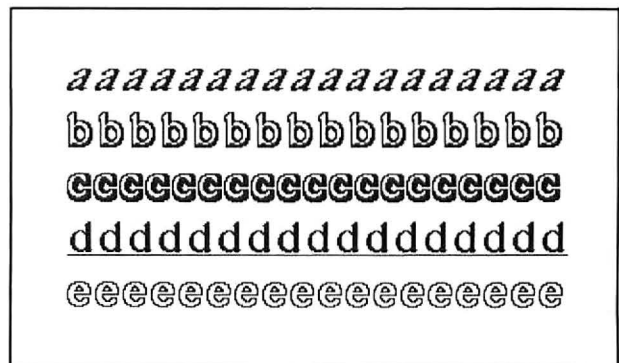

Figure 12
Each row of letters in this design is in a different font, yet no row is emphasized over the others. Designs with too many contrasting elements make the reader uncertain about what he or she is supposed to look at.



"SEEING MIGHT BE BELIEVING... BUT HEARING IS INCREDIBLE!"

"NOW YOU'RE TALKING!"



ANNOUNCING THE SOFTWARE PROGRAM THAT TALKS
STRICTLY BUSINESS[™]
 ACCOUNTING SYSTEM / MODULE ONE: GENERAL LEDGER

Now you can have it all! Comprehensive data immediately visualized **plus** commands, error messages and input accuracy all clearly **vocalized!** Listen as "Strictly Business" tells you the how to's, analyses and don'ts of accounting. The unique Smooth Talker[™] feature throughout the program makes accounting on the Macintosh[™] easier and more complete than any other software. When you see what it does and hear what it says, you'll know... **there's no comparison!**

Other modules to follow. Dealer inquiries welcomed!
 Circle 169 on reader service card

Module One: General Ledger... "Strictly Business" includes **everything** you need to keep your books straight:

- Smooth Talker — On/Off Capability • Help Screens
- Transaction Files — Batch Controlled • Budget Analyses
- Up to 5-Digit Chart of Accounts • Year-End Procedures
- Multiple Profit Centers • Individualized Journals
- Detailed System Reports

For more information and to order, call or write:



Future Design Software
 13861 Williamette Drive
 Westminster, California 92683
 (714) 891-9796

Smooth Talker is a licensed trademark of First Byte. Macintosh is a licensed trademark of Apple Computer, Inc.

AVAILABLE NOW

**Real Estate
 and Financial Analysis
 on The Macintosh[™]**

Four Packages of Advanced Multiplan Models:

Package #1, for Income-Producing Real Estate: Includes detailed cash flow/sensitivity analysis, annual property operating schedule, and more.

Package #2, for General Financial Analysis: Six models, including personal financial statement, critical ratio analysis, lease vs. buy, and more.

Package #3, for Commercial Real Estate Development: Extensive project cost analysis, multi-unit income-and-expense schedule, and lease-tracking model.

Package #4, for Residential Real Estate: Market Analysis by linear regression, mortgage qualifier, and rent vs. buy analysis.

Each package, \$100 plus \$5 shipping
 Complete set of four **\$325 plus \$10 shipping**
 and receive **free bonus: Financial Calculator Models**
 MC/VISA accepted. UPS Air Freight, no extra charge

RD RealData, Inc., P.O. Box 691 Southport, CT 06490
 203-255-2732 To order, call or write today.

Multiplan is a trademark of Microsoft Corp Macintosh is a trademark of Apple Computer, Inc.

Circle 49 on reader service card



**Macintosh[™]
 3 1/2" Diskette
 Duplication**

- Complete Duplication Capability
- Software Protection Available
- 100% Quality Control

REPLITEK's[™] complete duplication service includes: protection, serialization, packaging, and kit assembly. Other supported formats, for systems using 3.5" media, are also available. Additional formats available upon request.

All 5.25" formats are available at competitive prices. Call today for further information.

Macintosh is a registered trademark of Apple Computer, Inc.



Replico Technologies Corporation
 834 Charcot Avenue
 San Jose, California 95131
 408/945-1697

Circle 39 on reader service card

PC NETWORK

WHOLESALE + 8% PRICING

OUR 500 PAGE CATALOG OF 20,000 COMPUTER PRODUCTS
AND 14 TO 28 DAY SOFTWARE RENTALS†
FOR NETWORK MEMBERS ONLY!

Listed below are just a few of the over 20,000 products available at our EVERYDAY LOW PRICES! All software below is priced in Macintosh format. The NETWORK carries software for IBM, Apple II, CP/M, Kaypro and over 50 other popular systems.

GAMES & EDUCATIONAL

(Please add \$1 shipping and handling for each title ordered from below.)

Advanced Ideas <i>Lucky's Magic Hat</i>	24.00*	Infocom <i>Zork II</i>	29.97*
Axlon <i>Art Portfolio</i>	35.97*	Intelligent Statements <i>Professional Blackjack</i>	47.97*
Blue Chip <i>Baron</i>	35.97*	Mark of The Unicorn <i>Mouse Stampede</i>	23.97*
Blue Chip <i>Millionaire</i>	35.97*	Miles Computing <i>Mac the Knife</i>	23.40*
Blue Chip <i>Tycoon</i>	35.97*	Mirage Concepts <i>Trivia</i>	29.97*
CBS Software <i>Murder by the Dozen</i>	25.97*	Origin Software <i>Oger</i>	35.97*
Datapak Software <i>MAC SLOTS</i>	CALL	Penguin Graphics <i>Magician</i>	28.97*
Hayden <i>Sargon III</i>	29.97*	Penguin <i>Pensate or Xyphus</i>	21.97*
Hayden <i>DaVinci—Houses</i>	29.97*	Penguin <i>Transylvania</i>	20.97*
Hayden <i>DaVinci—Interiors</i>	29.97*	Priority Software <i>Forbidden Quest</i>	26.97*
Hayden <i>DaVinci—Landscapes</i>	29.97*	Scarborough <i>Mastertype</i>	29.00*
Hayden <i>Word Challenge</i>	23.97*	Scarborough <i>Fun for the Money</i>	29.97*
Infocom <i>Deadline</i>	35.97*	Sierra <i>On-Line Frogger</i>	23.97*
Infocom <i>Enchanter</i>	29.97*	Simon & Schuster <i>Typing Tutor III</i>	34.00*
Infocom <i>Planet Fall</i>	23.97*	T/Maker <i>Click Art</i>	29.97*
Infocom <i>Seastalker</i>	23.97*	Videx <i>Fun Pack</i>	23.40*
Infocom <i>Sorcerer</i>	29.97*	Videx <i>Mac Checkers & Reversi</i>	29.40*
Infocom <i>Suspended</i>	35.97*	Videx <i>Mac Vegas</i>	35.40*
Infocom <i>Zork I</i>	23.97*	Videx <i>Mac Gammon & Cribbage</i>	29.40*

BUSINESS SOFTWARE

(Please add \$2.50 shipping and handling for each title ordered from below.)

ATI MAC Coach	45.00*	Microsoft <i>Basic</i>	85.00*
Creative Solutions <i>MacForth Level I</i>	89.00*	Microsoft <i>Chart</i>	71.00*
Creative Solutions <i>MacForth Level II</i>	149.00*	Microsoft <i>File</i>	110.00*
Desktop Software <i>1st Base</i>	117.00*	Microsoft <i>Multiplan</i>	105.00*
Dillithium <i>PC to MAC & Back w/cables</i>	90.00*	Microsoft <i>Word</i>	110.00*
Dow Jones Software <i>Straighttalk</i>	45.00*	Odesia <i>Helix</i>	237.00*
Funsoft <i>Macasm</i>	60.00*	Softstyle <i>EpStart (USE YOUR EPSON ON A MAC)</i>	23.97*
Haba <i>Habadox</i>	CALL	Softsync <i>Personal Accountant</i>	54.00*
Harvard <i>MacManager</i>	29.95*	Software Arts <i>TK Solver</i>	148.00*
Human Edge <i>Communications Edge</i>	117.00*	Software Publishing <i>PFS: File & Report Bundle</i>	108.00*
Human Edge <i>Management of Sales Edge</i>	145.00*	Software Publishing <i>PFS: File</i>	68.00*
Human Edge <i>Mind Prober</i>	29.97*	Software Publishing <i>PFS: Report</i>	68.00*
Living Video Text <i>Think Tank</i>	75.00*	Stoneware <i>DB Master</i>	195.00*
Main Street <i>Main Street Fair</i>	177.00*	Telos Software <i>Felision</i>	117.00*
Main Street <i>Main Street Writer</i>	117.00*	Tronix <i>Monogram Dollars & Sense</i>	69.97*
Megahaus <i>Megamerge</i>	75.00*	Videx <i>Macaland</i>	53.00*
Megahaus <i>Megafiler</i>	117.00*		

HARDWARE

(Add 2% to the member price for each item for shipping and handling.)

COMPLETE SYSTEMS

Apple <i>Macintosh Base System</i>	1,580.00*	(34, 12)
Apple <i>Apple IIc</i>	860.00*	(16, 58)
Apple <i>Apple IIe</i>	CALL	
Columbia <i>Desktop & Portable Systems</i>	CALL	
Compaq <i>All Models</i>	CALL	
Eagle <i>Desktop PC and Spirit Portables</i>	CALL	
IBM <i>PC Starter System 1 DSDD-FDC/Color CD-Par Port/Monitor/64K</i>	1,620.50*	(35, 00)
IBM <i>PC Base System 2 DSDD/FDC 256k</i>	1,581.40*	(34, 16)
IBM <i>PC Professional Hard Disk (XT) (1 DSDD/FDC/10MB Hard Disk/256K)</i>	2,146.40*	(46, 36)
IBM <i>PC/AT All Configs</i>	CALL	
Sanyo <i>MBC 550 "Lowest Cost Compatible"</i>	620.00*	(13, 39)
Tava <i>PC Complete IBM Compatible (8-K/Color or Mono Card/2 drives)</i>	1,375.00*	(29, 70)
Texas Instruments <i>Professional</i>	CALL	

DISK DRIVES

Apple <i>400KB External Drive</i>	351.00*
Corvus <i>5.5 MB Hard Drive</i>	1,295.00*
Corvus <i>11.1 MB Hard Drive</i>	1,995.00*
Corvus <i>16.6 MB Hard Drive</i>	2,295.00*
Corvus <i>45.1 MB Hard Drive</i>	3,595.00*
Davong <i>5 MB External Hard Disk</i>	1,496.00*
Davong <i>10 MB External Hard Disk</i>	1,800.00*
Davong <i>15 MB External Hard Disk</i>	2,100.00*
Davong <i>21 MB External Hard Disk</i>	2,480.00*
Davong <i>32 MB External Hard Disk</i>	3,000.00*
Davong <i>40 MB External Hard Disk</i>	3,380.00*
Tecmar <i>5 MB Removable Drive</i>	1,350.00*
Tecmar <i>10 MB Mac Drive</i>	1,350.00*
Tecmar <i>Mac Drive Upgrade</i>	1,295.00*

MODEMS

Apple <i>Modem 300</i>	169.00*
Apple <i>Modem 1200</i>	371.00*
Microcom <i>Mac Modem</i>	350.00*
Novation <i>Cat Communication System</i>	324.00*
Prometheus <i>MacPack</i>	322.00*

PRINTERS

Apple <i>Imagewriter 10" Carnage</i>	446.00*
Apple <i>Imagewriter 15" Carnage</i>	530.00*
Epson <i>FX 80 10" Platen 100 CPS</i>	267.00*
Epson <i>RX 80 10" Platen 100 CPS</i>	220.00*
Okidata <i>ML-93/Mac/Apple 15" Platen 160 CPS</i>	586.00*
Okidata <i>ML-92/Mac/Apple 10" Platen 160 CPS</i>	367.00*
Imagewriter <i>Look-Atke</i>	

ACCESSORIES

(Freight minimum \$1 per item)

Apple <i>Macintosh Carrying Case</i>	74.00*
Apple <i>Macintosh Security Kit</i>	37.00*
Apple <i>Numeric Keypad</i>	74.00*
Intermatrix <i>Magic Phone</i>	119.97*
Innovative Concepts <i>Flip N File II</i>	28.08*
Innovative Concepts <i>Flip N File Micro (25)</i>	6.69*
Koala <i>MacVision</i>	210.00*
Kensington <i>Disk Case</i>	20.00*
Kensington <i>Dust Cover</i>	8.25*
Kensington <i>Startup Pack</i>	54.00*
Kensington <i>Surge Protector</i>	33.47*
Kensington <i>Saver</i>	21.00*
Kensington <i>Ponable Modem</i>	91.00*
Maxell <i>Mac Diskettes (Box of 10)</i>	37.00*
Micron Tech <i>Micron Eye</i>	275.00*
Mouse Systems <i>At Mouse</i>	97.00*
PC Network <i>Mac Diskettes (Box of 10)</i>	30.00*
SRW <i>Champaign Disk Box</i>	2.70*
SRW <i>Blue Disk Box</i>	2.70*

*PC Network Members pay just 8% above the wholesale price, plus shipping. All prices reflect a 3% cash discount. Wholesale prices fluctuate rapidly—all prices in this issue have been prepared 60 days in advance. Please call for latest prices. Minimum shipping \$2.50 per order.

For as little as \$8 per year you can join the thousands of value wise buyers who have saved more than \$22,000,000 on 60,000 orders in just the last six months and received these 15 unique benefits:

- Cost + 8% Pricing
- Our 500 Page Wholesale Catalog
- In-Stock Insured Fast Home Delivery
- 10 Day Hardware Return Policy
- Membership Satisfaction Guarantee
- Experienced Consultants
- Free Technical Support
- Optional Business Rental Library
- Optional Game Software Rental Library
- Special Savings Bulletins—The Print-Out
- Discount Book Library
- Membership Referral Bonus
- Corporate Account Program
- Quantity Discounts
- Price Protection

CALL TOLL FREE
1-800-621-S-A-V-E

In Illinois call (312) 280-0002

Your Membership Validation Number: U725

You can validate your membership number and, if you wish, place your first money-saving order over the phone by using your VISA, MASTERCARD or AMERICAN EXPRESS. Our knowledgeable service consultants are on duty Mon.-Fri. 8 AM to 7 PM, SAT. 9 AM to 5 PM CST.

PERSONAL COMPUTER NETWORK
320 West Ohio
Chicago, Illinois 60610

Call now... Join the PC NETWORK and start saving today!



PC NETWORK • MEMBERSHIP APPLICATION

YES! Please enroll me as a member in the PC NETWORK™ and rush my catalog featuring thousands of computer products, all at just 8% above DEALER WHOLESALE PRICES. I will also periodically receive "THE PRINTOUT", a special up-date on merchandise at prices BELOW even those in my wholesale catalog and all the other exclusive, money-saving services available to Members. U725

I am under no obligation to buy anything. My complete satisfaction is guaranteed. Please check all boxes that apply.

Basic Membership Special V.I.P. Membership*

One-year membership for \$8 One-year membership for \$15

Two-year membership for \$15 (SAVE \$1) Two-year membership for \$25 (SAVE \$5)

Business Software Rental Library for \$25 add'l per year—with 14 day rentals BOTH Business and Game Software Rental Libraries for \$30 add'l per year—with 28 day rentals

Games Software Rental Library for \$10 add'l per year on limited quantity merchandise specials *VIP members receive advance notice

Bill my credit card VISA MasterCard American Express

Account Number

Exp. Date mo year

Check or money order enclosed for \$

Name

Address Apt. No.

City State Zip

Telephone

My computer(s) is Apple II Macintosh Lisa IBM PC Other

Signature (Signature required to validate membership)

Copyright ©1984 PC NETWORK INC

†RENT BEFORE YOU BUY—Members are eligible to join The NETWORK's Business and Game Software Rental Libraries and evaluate products for a full 14 (Regular) or 28 (VIP) days to see if it meets your needs. And The NETWORK's rental charges are far less than other software rental services—JUST 20% OF THE MEMBER WHOLESALE PRICE.

Circle 45 on reader service card

MACTYPE FROM PALANTIR. THE TYPING TUTOR THAT IS

F

FIRST

Palantir knows that if your Macintosh™ is to be fruitful, you must first conquer the keyboard. And for many, that means learning how to type. So, Palantir created MacType. It's the first typing tutor for the Macintosh to put to use benefits of proven teaching techniques that speed up learning. Simply, MacType uses mental patterning to reinforce manual exercises. It teaches your fingers and your brain rather than your eyes, and you learn more quickly. If one of your first tasks on the Macintosh is to learn how to type, think of MacType first.

A

ADVANCED

Palantir designed MacType to be the most advanced typing tutor for the Macintosh that is available today. MacType takes full advantage of Macintosh's flexible screen displays and the simple functioning of its mouse to teach you how to type. All the know-how that has gone into the most complex Palantir Software was used in the development of MacType. You're getting state-of-the-art technology even in this basic program. It takes advanced skill to create a fundamental program that is both fun and mental for the user. And you get MacType's advanced features at a price that is very competitive.

S

SIMPLE

Palantir has also designed MacType so that it is amazingly simple to learn and use. Because of the teaching principles inherent in the program, you will get up to an effective typing speed in a very short time. You can also use the skills you learn on MacType to operate any typewriter keyboard, not just the Macintosh. Compared to the other typing tutors, MacType will actually let you enjoy learning. You may like it so much that even after you've mastered its touch-typing technique, you'll go back to the MacType exercises to sharpen your skills and increase speed. MacType shows that working smart can be working simple.

T

TESTED

Palantir thoroughly tested MacType to insure that it will work for you. With it you will learn to type fast. MacType should be your first choice. It is based on advanced programming technology and is still simple to learn. MacType is another quality, "No Bull" product from Palantir. If you want to learn more, contact

**PALANTIR®
SOFTWARE**



MACTYPE™



MACINTOSH IS A TRADEMARK LICENSED TO APPLE COMPUTER, INC.
PALANTIR AND MACTYPE ARE TRADEMARKS OF PALANTIR, INC.

**PALANTIR SOFTWARE · 12777 JONES ROAD · SUITE 100
HOUSTON, TEXAS 77070 · CALL TOLL FREE 1-800-368-3797
IN TEXAS CALL 713-955-8880**

Circle 74 on reader service card

SUN OL
SYS TEMS

and

**APPLE
COMPUTER**

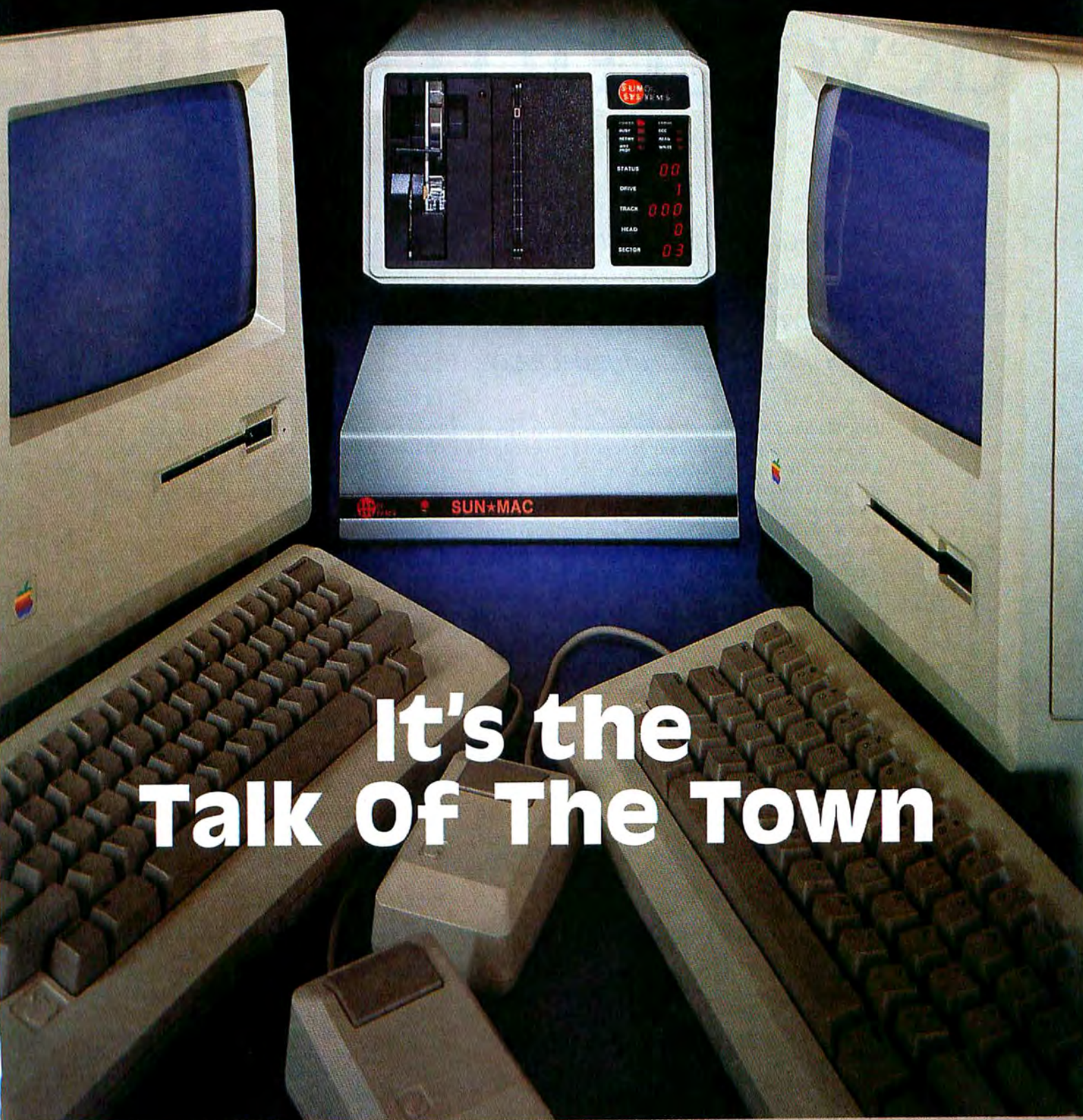

**It's the
Talk Of The Town**

P.O. BOX 1777 1187 QUARRY LANE PLEASANTON, CA 94566 TELEX 703175 (415) 484-3322

Circle 132 on reader service card



Announcing the only devoted to one little

*Sponsored by Macworld,
the Macintosh Magazine
February 21-23, 1985
Brooks Hall, San Francisco*

If the Macintosh has become the Apple of your eye, you won't want to miss this very special, very exciting computer show—the *Macworld Exposition*. It's the first and only computer festival devoted entirely to the Macintosh—a three-day, fun filled, hands-on event! This is your chance to take a Macintosh for a test spin, see hundreds of product exhibits, compare Mac-related peripherals and software, plus much, much more!

If you're interested in what this little box of computing dynamite can do for you, join us at Brooks Hall, February 21-23.

Special Show Schedule

Thursday, February 21—Trade and Press Day

Open to the trade, press, and corporate users only. A day of opportunity! *Resellers*—strike your deal with manufacturers. *Press*—your chance to analyze the market and see new products. *Corporate users*—your chance to see how the Mac can help your business.

Friday and Saturday, February 22-23—Open to the Public

Your chance to participate in:

- The Gallery of Mac Art
- The Mac Playground filled with Macs for you to play with
- The Mac Clinic—a problem-solving workshop
- Conference programs filled with information to meet every need
- Plus, visit an Exposition Hall filled with Mac-related products

Take a Mac for a Test Spin

Hundreds of Macintoshes will be on the floor for everyone to use! Potential buyers can get a hands-on test drive. Users of other micros can compare the Mac to their own machines. See just what the Mac can do for you!

Free Mac Software Clinic

Experienced Mac users and software experts will be on hand all three days to answer your Mac questions and help you find the products that will best fit your needs. The Software Clinic is *free* with your paid admission!

Over 100 Mac Exhibits

Come see the newest hardware, software, and peripherals being developed for your Macintosh. See for yourself—all in one place—the many products available now that will help your Mac work faster, easier, and smarter.

Here's What You'll Learn

- All about home, office, and school software
- How to use the Mac in business
- All about Fat Mac
- Getting the most out of your spreadsheet programs
- When and how to use MacBasic
- Plus hundreds of other Mac tips

Who Should Attend?

Business: CEOs, presidents, vice presidents, managers, comptrollers, owners/partners

Professionals: Doctors/nurses, bankers, lawyers, engineers, stockbrokers, real estate and insurance agents, CPAs, consultants

Education: Administrators, faculty, students

Industry: Dealers, retailers, wholesalers, manufacturers, systems houses, consultants, technical programmers, all other ISOs



big computer show computer.

Thursday, February 21: Industry/Press Sessions

- 10:00-11:30— Industry forum: The outlook for the Macintosh in the office
- 11:30-12:00— Industry roundtable discussions
- 12:00-1:00— Lunch break
- 1:00-2:30— Industry forum: Developing software for the Mac—opportunities and pitfalls
- 2:30-3:00— Industry roundtable discussions
- 3:00-4:30— Industry forum: The outlook for the Macintosh in the home and school
- 4:30-5:00— Industry roundtable discussions

Friday, February 22: Business/General-User Sessions

- 12:00-2:00— Keynote presentation: The future of the Macintosh and what it means to you
- 2:00-3:00— How to start and survive in business with your Macintosh • Maximizing *MacPaint* • The Mac Clinic
- 3:00-4:00— Interfacing the Mac with other Apples • A guide to better business graphics • How to create useful documentation
- 4:00-5:00— What the Fat Mac can do • Maximizing *MacWrite* • Putting LANs to work for you

Saturday, February 23: Education/General-User Sessions

- 12:00-1:00— The Macintosh in the classroom • All about MacBASIC • Unveiling the Mac's hidden features
- 1:00-2:00— The Mac in higher education • All about MacPascal • How to write user-friendly software



- 2:00-3:00— Developing university courseware with the Mac • Data base management with the Mac • How to become a wizard at machine-language programming
- 3:00-4:00— Understanding the power of peripherals • Getting the most out of spreadsheet programs • File management tips and techniques
- 4:00-5:00— How to get your programs published • What's available in Mac software • Maximizing Mac's disk storage

The Macworld Exposition is produced by World Expo Co. and managed by Mitch Hall Associates. For further information, call Mitch Hall Associates at (617) 329-7466 or (617) 329-8091. Macworld Exposition is a registered trademark of World Expo Co., Inc. MacBASIC, *MacPaint*, MacPascal, and *MacWrite* are registered trademarks of Apple Computer. Macintosh is a trademark licensed to Apple Computer.

**MACWORLD
EXPOSITION**
SAN FRANCISCO

Circle 174 on reader service card

Introducing Typing Intrigue.™

Now there's hope even for executives hardened by years of typophobia, arcade-shocked junior high school students, and anyone else who needs to get all ten fingers working together, at last.

Typing Intrigue takes the drudgery out of improving your typing skills. It makes learning to type enjoyable, so you'll stay with it. And that makes it really *effective*.

Like a truly professional teacher, Typing Intrigue adjusts itself to your level. It recognizes you (and up to 5 other "pupils") and designs its lessons accordingly, recording your progress from session to session. It's never repetitive, never boring, and keeps you motivated.

As your skill improves, you earn clues toward solving *The Case of the Missing Bathtub*. Where might one hide



a £50,000 onyx and gold antique tub? And why? How are Reginald Chumley and Lady Deirdre Dunsmire involved? Where did the worn elbow-patches come from? Do those rumors about Lord Southby mean anything?

By the time these characters help you break the case, you'll be typing at breakneck speed.

You can also improve your typing skill with a second game option—*Rain*—a fast-moving, arcade-type challenge for those

who like more action.

Of course, you don't have to brave a thunderstorm or get involved with Inspector Hargreaves' puzzling bathtub case if you choose to just roar through the typing exercises undiverted. But who can resist a good thriller?

Contact your Macintosh™ dealer, or call 1 800 MACWARE™ to find out where you can get Typing Intrigue.

From Forethought, Inc.



MACWARE™

Circle 144 on reader service card

These characters can teach anybody to type.



Creative Inspiration

Give inspiring new programs for your Macintosh™ from Axlon. You'll find these programs at better Apple dealers right now. (Or any day now.)

One

Art Portfolio™ \$59.95

A diskfull of professionally drawn artwork with the best 100 page manual of tips and ideas available! If you like to MacPaint™ and wish to unleash your creativity, then Art Portfolio™ is for you. It includes an index of the artwork and hundreds of ideas to create exciting memo's, letters, cards, etc. All the images are the right size to use in your documents or you can expand, reduce or modify them with minimal distortion. Create-a-Card™ instructions include ideas for making your own greeting cards.

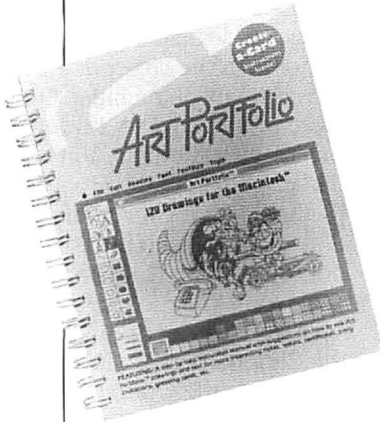

Two

The Card Shoppe™ \$59.95

Here's everything you and your MacPaint program need to get into the card-making business.

- ▶ Special drawings, ranging from the obvious to the obscure.
- ▶ A complete, exuberant calendar of holidays and greeting card occasions, if you need one to create a card.

▶ A see-through formatting overlay for your Mac screen that lets you position your art and words before you print, so you know it will fit properly on your card when folded.

▶ Samples of paper and envelopes for your ImageWriter. Best of all, The Card Shoppe gives you a ton of creative ideas for your own special cards for your own special purposes.

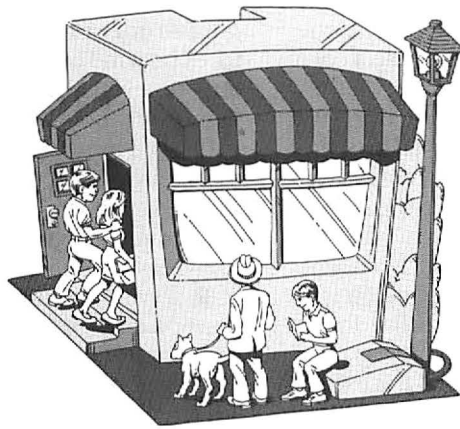

Three

MacMatch™ \$49.95

This is one of the first of a new breed: Native Macintosh games. Our software gamemakers have taken their inspiration from the tv game show, Concentration™, and have built it on the Mac's quickness and graphics power. When you match two squares, you get clues about the hidden puzzle. It comes with puzzles, but the real beauty is that you

can make up your own, as complex or simple as you like. You'll never get bored. And think what party puzzles might look like...

Four

MouseTracks™ \$49.95

We put Mac's considerable graphics skills through the loops to develop an eye-popper for Mac's first mouse game.



You will zoom an animated mouse through a maze-like environment avoiding a bad kitty cat intent on supper. There are plenty of perils and rewards for the skillful. MouseTracks shows everyone how much fun Macintosh can be.

Five

Typing Avalanche™ \$59.95

Since man does not live on art alone, but by lots of words that flow from the mouth of Mac, we've commissioned the first typing strategy program for the Mac. It's aimed at the poor duck who somehow got through school without learning touch typing. (The rest of us, in other words.) It's fast paced. It's fun. And it works. Play it a while, and you'll suddenly realize you are a touch typist. Someday the schools will catch up.

New from Axlon. Now at your Apple Computer Dealer.

If you can't find it there, call us for the name of a nearby dealer: 408-747-1900.



Axlon Inc.
1287 Lawrence Station Rd.
Sunnyvale, CA 94089

Open Window

An exchange of Macintosh discoveries

Edited by Daniel Farber

Open Window offers tips to help you use your Macintosh more efficiently. Submitted by readers, industry experts, and the Macworld staff, items in this department address all facets of Mac work, from applications to programming routines to capabilities of the Mac and software not covered in the documentation.

This month's Open Window unveils a technique for enlarging MacPaint images, a clever way to utilize the Note Pad, an undocumented MacPaint shortcut, and a few tips for using MacWrite. Other items include a quick way you can determine whether a file is locked, some advice for transporting your Mac when you travel by air, and a method for plotting standard deviation and standard error graphs with Microsoft Chart. A special feature this month is a Cairo font "Key Caps," which you can cut out or photocopy to display as a reference card.

MacWrite: Colon

In reading your *MacWrite* manual, you may have noticed the advice that you not use a colon in a document name. This information is not strictly true. If you have an external disk drive, you can use a colon in a document name to save the document to a disk in the other disk drive. For example, if a document you are working on is on the disk in the internal drive, and you want to save the document to the disk in the external drive, choose the Save As command and type the name of the disk in the external drive, followed by a colon and the name of the document. The document is then saved to the disk in the external drive. Of course, you can accomplish the same task by clicking the external drive button and typing in the document name.

Judy A. Evans
Zion, Illinois

Enhanced Enlargements in MacPaint

When I began creating shaded drawings in *MacPaint* [see the figure "Original Drawing"], I found that enlargements of the drawings left a lot to be desired. When I enlarged a draw-

ing by surrounding it with the selection rectangle and dragging an edge outward, the textures became coarse and patterns uneven. For a while I contented myself with using the expanded drawing as a guide to redrawing, but then I discovered a way to improve the appearance of enlarged drawings.

To solve the problem of uneven patterns, you should keep the image to scale (hold down the ⌘ and Shift keys while stretching the image) and enlarge it in multiples of the original size. To make an image twice its original size, for example, place two copies of the drawing next to each other and enlarge the original so it just covers the copies. This procedure produces uniform dots that are twice the size of those of the original [see the figure "Crude Enlargement"].

The coarse texture of the new drawing is still a problem, however; every dot in the original drawing has turned into a large dot made up of four original-size dots. The first step in refining the chunky texture is to block out three of the four dots in each of the large dots that make up the image. To mask out the extra dots, first select the entire image and choose Invert from the Edit menu.

Then you must cover the negative image with a "masking" texture. Set the line width to the dotted line (no border), select the fifth pattern from the left in the top row of the pattern palette. Press the ⌘ key while opening up a filled rectangle over the image (this technique will not work with version 1.1 of *MacPaint*). The dots in the negative image are smaller and the patterns finer in texture than before it was masked.

Next, select the image and choose Invert again. This step produces a very light positive image made up of single dots, rather than the larger dots of the original enlargement. One more problem exists, however: the image is too light. You can darken the drawing by copying the light image over itself several times, skewed by just a few dots each time. This procedure takes some practice, so store a spare copy of your drawing in the Clipboard. Lasso the image, hold down the Option key, and drag the resulting copy just a dot or two away from the original. Release the Option key, then press it again immediately and drag a second copy a few

**Original
Drawing**

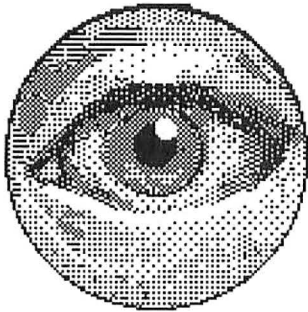

**Crude
Enlargement**

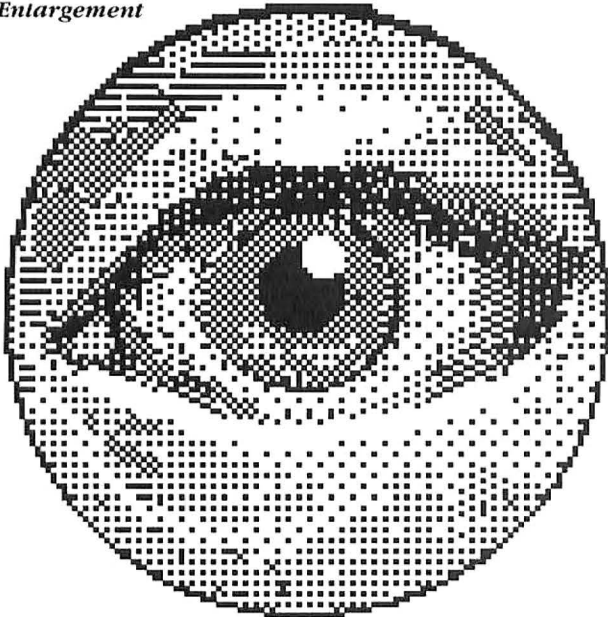

**Enhanced
Enlargement**

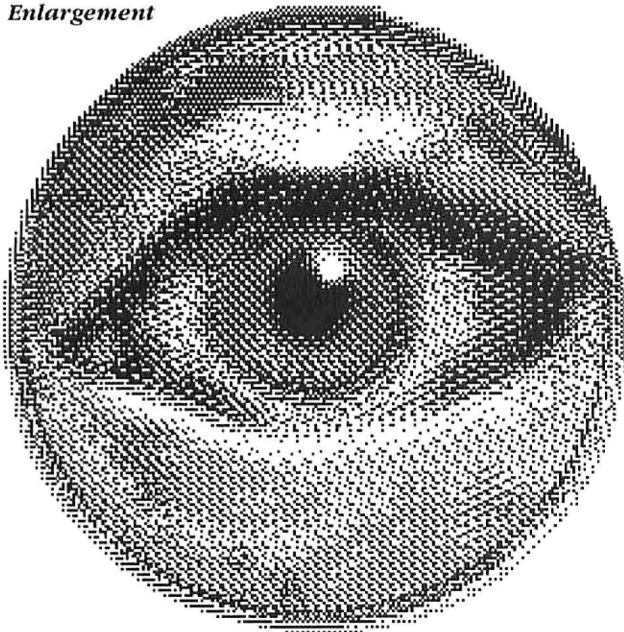

Enhanced Enlargements

Compare the original drawing to the crude enlargement example. As you can see, textures become coarse when enlarged. To get the crude enlargement effect, select your original drawing and stretch it by holding down the **⌘** and **Shift** keys while dragging the image. The image should have dots twice the original size. The enhanced enlargement example shows the final result of the process.

dots to one side. Repeat this procedure until your drawing looks satisfactory [see the figure "Enhanced Enlargement"]. You can position each copy for the textural quality, sharpness of edge, and contrast you want for the final image.

After enlarging your image and enhancing the texture, you may want to sharpen edges or redraw lines. The steps described here may seem somewhat complicated at first, but with some practice the process can be carried out quickly.

*Young Harvill
Stanford, California*

Right Margin Justified

Right and left margin justification is a nice feature, but sometimes large, ungainly gaps are introduced between words, interfering with ease and speed of reading. Some word processing programs recognize a hyphen as a legitimate line break, just like a space. *MacWrite*, however, does not. To circumvent the problem, insert a hyphen and a space where you want to break a word at the end of a line [see the figure

"MacWrite Justified"]. This technique works well for creating short documents, but for long documents it can be a chore.

*Edgar Wirt
Ann Arbor, Michigan*

Note Pad Reference

I have discovered that the Note Pad can be quite useful when creating academic manuscripts. I was looking for a way to record reference citations while drafting the text of a manuscript. In my pre-Macintosh days I had a system of simply writing the reference on a 3- by 5-inch index card and alphabetizing the stack before typing the reference section at the end of the manuscript. With the Mac, I can record citations in the Note Pad. When I finish the manuscript text or fill up the Note Pad, I open a new *MacWrite* document and cut and paste the citations from the Note Pad into the newly created reference document. I usually alphabetize each page of the Note Pad before cutting it and alphabetize the reference document after each page is pasted in. By slightly raising the bottom edge of the *MacWrite* document window, I can provide

Open Window

enough space for part of the Note Pad to be visible. This arrangement allows me to go back and forth between my document and the Note Pad easily, without using the menu command [see the figure "Note Pad Reference"].

The one problem with this technique is that the Font and Style menu options are disabled when you use the Note Pad, so you can't underline or use italics for journal names or book titles. Of course, you can make all the necessary enhancements in the *MacWrite* reference document. This limitation subtracts from the overall utility of the technique, but it is a small price to pay to get rid of boxes of index cards.

*Fred S. Wambolt
Madison, Wisconsin*

Looking for Locked Files

Trying to throw away locked documents can be frustrating. The beep and the alert box that appears when you attempt to drag a locked file to the Trash are annoying. Even worse, if you have a single-drive Mac, the startup disk must be inserted in the disk drive so the computer can read the error message from the startup disk and show it on the screen. The Get Info window for a document indicates if it is locked, but displaying the information and restoring the desktop take time. When documents to be deleted are on the disk in the disk drive, a quick way exists to determine if the documents are locked. If more than one document is selected, click between documents so that none of the documents is selected. Then

Whether the Court will consider these practices unconstitutional has not been ascertained by our staff of legal experts.

Whether the Court will consider these practices unconstitutional has not been ascertained by our staff of legal experts.

MacWrite Justified

MacWrite does not recognize a hyphen as a legitimate line break, so justified text often has large gaps. You can overcome this problem to a degree by dividing the first word in the second line and adding spaces so that the first part of the word jumps back to the first line.

move (not drag) the cursor across the names of the document or documents you want to delete. If the cursor changes to an I-beam, the document to which the cursor points is not locked. Otherwise, the document is locked, and you must unlock it by clicking the appropriate button in the document's Get Info window.

*Steve Fine
University Park,
Pennsylvania*

screen and want to work on areas of the picture that are far apart from each other. You can pinpoint the exact area you want to work on and then zoom in.

*Rick Blank
Philadelphia, Pennsylvania*

Packing Your Mac

I recently did some flying with my Mac, and have some advice for other people who take their machines on commercial airlines. Allow airport security personnel to x-ray your Mac. When set up for travel in an Apple carrying case (I haven't tried other types of packs), the Mac fits through an X-ray machine, and the X rays don't harm the computer. The magnets in the X-ray machine, however, can scramble the magnetic information on your disks, so have your disks hand inspected. As your Mac passes

Faster FatBits

I discovered a faster, more accurate shortcut to enter FatBits than double-clicking on the pencil in the tool palette. Using the pencil, point to the exact area of the image you want to modify in FatBits. Then, hold down the ⌘ key and click the mouse once. The screen will show FatBits at exactly the area where the pencil was pointing. To exit FatBits, hold down the ⌘ key again and click once (make sure you are using the pencil). This method works better than scrolling when you have a large picture on the

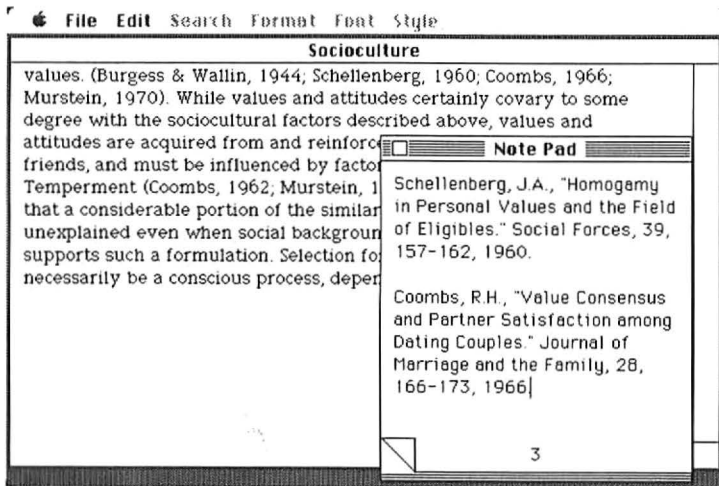

Note Pad Reference

The Note Pad can be used to record reference citations while you are writing the text of an article. When the Note Pad is full of citations, you can cut and paste them at the end of the manuscript or into a separate document.

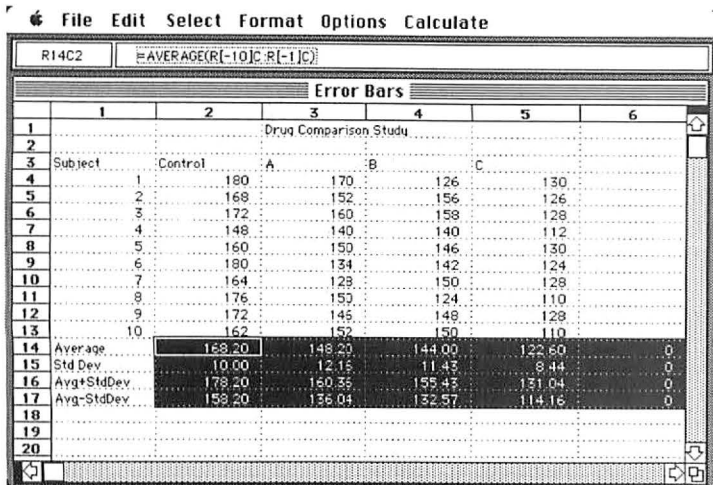

Error Bars 1

After you type in the data from the study, use Multiplan's built-in functions to calculate the standard deviation for each column.

through the X-ray machine, tell the security personnel that they are looking at a computer. Otherwise, they may insist on hand-inspecting it, which could make you late for your flight.

The Mac in its case can be stowed in the overhead bin of a Boeing 737. However, it doesn't fit in the overhead bin of an older jet, such as a Boeing 727, and it doesn't fit under the seat of either type of plane. The Boeing 727 has closets, and a friendly flight attendant will usually let you store your Mac in one.

Use a collapsible suitcase dolly to get your Mac from your car to the gate. The Macintosh may be a portable computer, but it's awkward to haul one around an airport if you're also carrying a suitcase or two. And once you've got your Mac to the

gate, set it up on a table near a grounded outlet and watch the crowd grow. It's a great way of passing time while you're waiting for your flight.

*Richard Wanderman
Eugene, Oregon*

Error Bar Charts

While *Microsoft Chart* is a powerful program, it lacks an important feature needed for creating scientific graphs: the ability to plot standard deviation or standard error bars. These error bars graphically indicate the degree of scatter about the average value of a set of numbers. All is not lost though, because using *Chart* with *Multiplan* yields the desired end product.

An example best illustrates the technique. Let's say you want to graph the relative effects of several drugs (A, B, and C) on blood pressure. You can

measure the initial blood pressure in ten test subjects and then measure their blood pressure following two weeks of each medication.

At the end of the experiment, the results can be tabulated with *Multiplan*. First, you type in the results of the study in the worksheet. You can instruct *Multiplan* to calculate the average blood pressure for each drug and the standard deviation. (Note that the standard error, if desired, is the standard deviation divided by the square root of the number of subjects.) Then, you can calculate the sum and difference of the average and the standard deviation for each column. Next, due to vagaries in the Clipboard interface between *Multiplan* and *Chart*, it is necessary to add an extra column of zeros to the calculated data, so that the number of columns exceeds the number of rows [as shown in the figure "Error Bars 1"].

Then copy the selected area to the Clipboard, quit *Multiplan*, and start up *Chart*. After the untitled Chart document appears, select the Sequence option from the Data menu. In the dialog box, set the Series Name to "Drug Comparison," the Category to "Drug," and the Value to "BP" (blood pressure). A series window named Drug Comparison will open. Then choose the Paste command, and four new series windows will appear [as illustrated in the figure "Error Bars 2"].

Select the sequential series containing the standard deviation and delete the entire series by clearing it from the Edit menu. Click the Plot Series box for the remaining three data series. Select the default (number 1) Combination chart from the Gallery menu, and then select the Overlay Chart option from

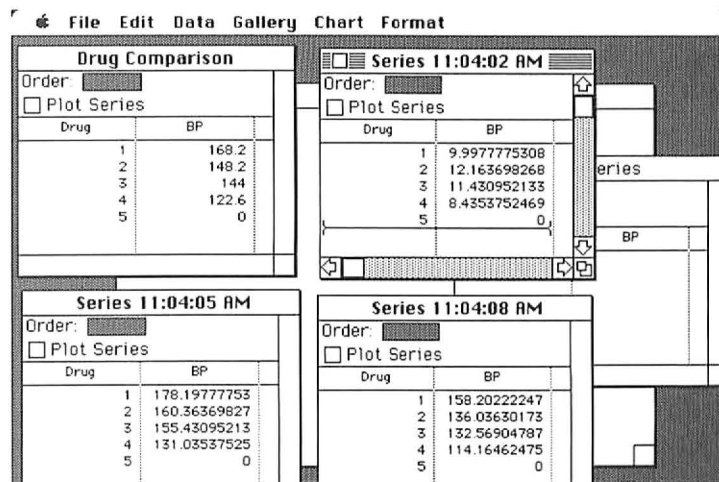

Error Bars 2

When you paste the data from Multiplan into Chart, four series windows are displayed. Delete the data from the standard deviation series window by choosing Clear from the Edit menu, and then click the Plot Series box for the remaining three series.

Lisa™
Software
from
Silent Partner™

A General Ledger that works the way *Lisa* works.

Finally an accounting tool that uses and enhances the power of Lisa's 7/7 system.

Pop-up lists make data entry as easy as pointing and clicking. This mouse based, graphically pleasing system combines simplicity with sophistication.

The General Ledger is the first part of a modern integrated accounting package. Coming soon... Accounts Receivable and Accounts Payable. See your Lisa dealer or call us for more information.



630 Park Street
 Suite 304
 Stoughton, MA 02072
 (617) 341-1856

INTERLOBAL™ SYSTEMS INC.

Bringing Creativity to Technology

APPLE, LISA, are trademarks of Apple Computer, Inc.
 SILENT PARTNER, is a trademark of Interlobal™ Systems Inc.

Circle 191 on reader service card

Open Window

the Format menu. In the Overlay Chart dialog box, set the button for "Hi-Lo" lines, click off Data Point Markers and Lines Connecting Data Points, and change the Starting Series from 3 to 2. Voilà, the chart appears. The final step is to customize the labels [as in the figure "Error Bars 3"].

Ira Rampil
San Francisco, California

Cairo Key Caps

I would like to share a tip concerning the new pictorial font, Cairo. After upgrading my *MacWrite*, *MacPaint*, and System disks, I needed a way to remember the keyboard locations of the Cairo characters. I used *MacPaint* to create a keyboard similar to the one in the Key Caps desk accessory. Next, I typed what I call the "lower-case" Cairo characters and moved them onto the appropri-

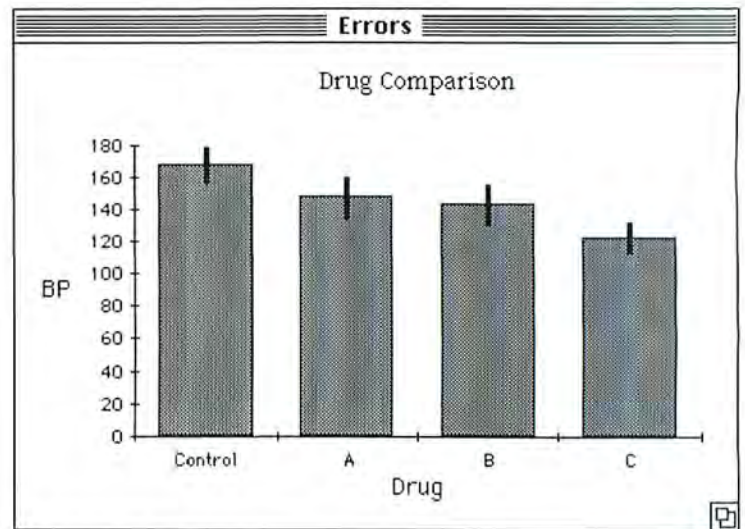

Error Bars 3

The "Drug Comparison" chart was created with the default Combination chart from the Gallery menu and the Overlay chart option from the Format menu. The labels were then customized to enhance the quality of the chart.

ate keys on the keyboard with the lasso. Then I cut and pasted the finished keyboard into the Scrapbook [see the figures "Upper Cairo Key Caps" and "Lower Cairo Key Caps"].

I followed a similar procedure in creating the "uppercase" Cairo keyboard. Whenever I want to know the keyboard location of a particular Cairo character, I open the Scrapbook and take a look. With MacWrite, you can keep the Cairo keyboard in view while you are working on a document. You can also print out the Cairo keyboards to create a quick reference sheet.

Burton S. Jaffe

Champaign, Illinois

Perhaps you've come up with a nifty routine, gained some insight into how the Mac or an application program works, or even written a short program that performs a useful function or creates an interesting diversion. Tell us about it, and we'll pass your discovery along. We'll also pay \$25 to \$100 for each Open Window item published. Please send your Macintosh discoveries on disk (which we will return) to Open Window, Macworld, 555 De Haro St., San Francisco, CA 94107, or electronically to CompuServe 74055,412 or The Source STE908. □



Upper Cairo Key Caps

You can create a keyboard similar to the Key Caps desk accessory and then position the Cairo characters individually on the keyboard at the appropriate keys. This keyboard displays the uppercase Cairo key locations.

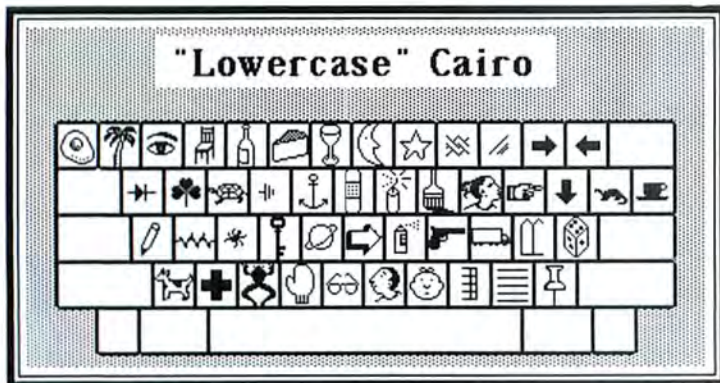

Lower Cairo Key Caps

You can store the Cairo Key Caps images in the Scrapbook or print them out on the Imagewriter to create a reference sheet. This keyboard displays the lowercase Cairo key locations.

Compuclassics

SOFTWARE	
ATI Mac Coach	\$ 45.00
Continental Software The Home Accountant	\$ 57.00
Desktop Software 1st Base	\$110.00
Intermatrix Mac Phone	\$125.00
Living Videotext Thinktank	\$ 85.00
Magnum Mc Pic	\$ 32.00
Mainstreet Mainstreet Filer	\$160.00
Microsoft Basic Interpreter	\$ 99.00
Chart File	\$ 85.00
Multiplan Word	\$125.00
Monogram Dollars and Cents	\$125.00
Software Publishing PFS File	\$ 97.00
PFS Report File Report Combo	\$ 70.00
Telos Software Filevision	\$ 70.00
	\$110.00
	\$119.00

Incredible Prices with Professional Support!

- Corporate accounts welcome
- We accept VISA & MasterCard
- No credit charge surcharge
- Free technical support

HOURS
Order desk & technical support open:
8 a.m. to 6 p.m. Monday-Friday
10 a.m. to 2 p.m. Saturday

TO ORDER CALL
1 (800) 328-4473 (818) 705-1895 (CA)

6934 Canby Street Suite 104 Reseda, CA 91335

SHIPPING
\$4 per item UPS surface (\$8 for Blue Label); printers \$25

TERMS
All prices subject to change. We honor Cashiers Check / MO / Bank Transfers immediately. Allow time for company & personal checks to clear. California residents add sales tax.

Circle 98 on reader service card



The MacPublisher™

VOLUME 1 NO.4

1985

BOSTON MA 02132

ELECTRONIC COMPOSITION FOR MACINTOSH™

The September '84 Scientific American predicted a computer that would "display a fair approximation of the pages it will print, including the placement of each item, and the typeface to be employed," and that would allow a user to "manipulate page geography directly by means of a mouse."

MacPublisher transforms your Macintosh into such a computer.

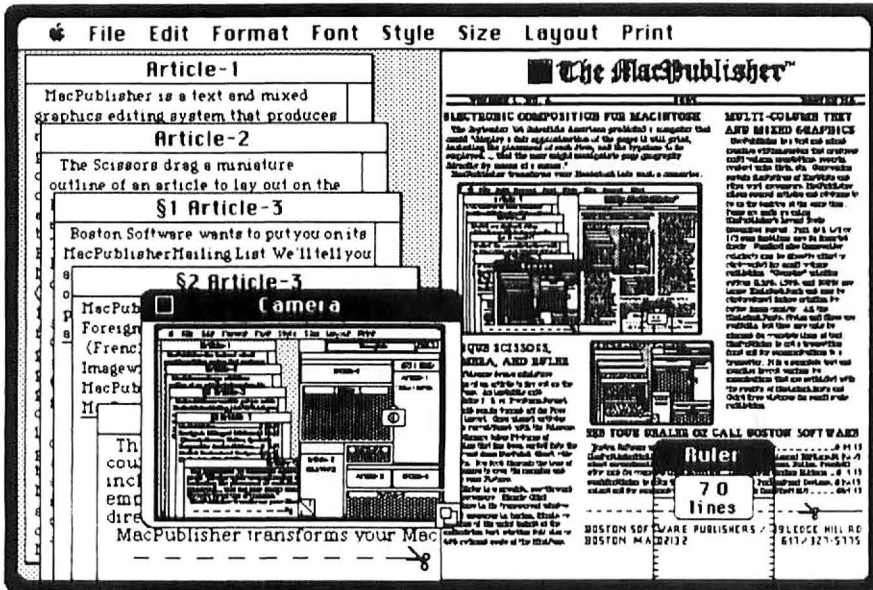

MULTI-COLUMN TEXT AND MIXED GRAPHICS

MacPublisher turns your Macintosh into a text and graphics editing, layout, and page-makeup system that produces multi-column newsletters, fliers, catalogs, ads, etc. Overcoming certain limitations of MacWrite and other word processors, MacPublisher allows several articles and pictures to be on the desktop at the same time. Articles may be clipped and carried over to other columns and/or pages.

Pages are made up using MacPublisher's Layout tools. The MiniPage shows you a "What You See Is What You Get" representation of a full page layout. The Dummy Page shows articles and pictures as blocks with numbers of lines, characters, and page, column continuations.

Standard size Imagewriter printouts may be directly offset or photocopied for small-volume publishing. If you are lucky enough to have access to Apple's new Laser Printer, your output quality rivals the best typesetting equipment. All the Macintosh Fonts, Styles and Sizes are available, but they may only be changed for complete lines of text. MacPublisher is not a typesetting front end for communications to a typesetter. It is a complete text and graphics layout package for organizations that are satisfied with the quality of Macintosh fonts and QuickDraw pictures for small-scale publishing.

UNIQUE SCISSORS, CAMERA, AND RULER

The Scissors drag a miniature outline of an article to be laid out on the MiniPage. An invisible grid maintains 1, 2, or 3-column format. The grid can be turned off for Free Form layout. Once dropped in place, articles can be repositioned with the Scissors.

The Camera takes pictures of anything that has been copied into the Clipboard from MacPaint, Chart, clip art, etc. You use a miniature "through the lens" Camera to crop the margins and frame your Picture.

The Ruler is a movable, see-through desk accessory. Simply Click anywhere in its transparent window and it measures in Inches, Pixels, or in Lines of the point height of the underlying text, whether full size or 44% reduced scale of the MiniPage.

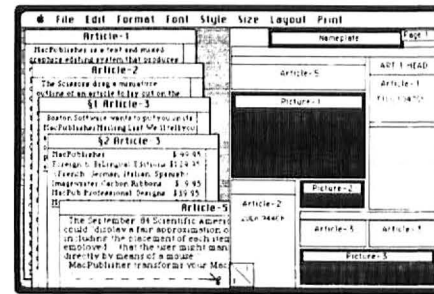

SEE YOUR DEALER OR CALL BOSTON SOFTWARE

Boston Software wants to put you on its MacPublisher Mailing List. We'll tell you about our carbon ribbons to enhance the output of your Imagewriter™, clip art for professional newsletters, and MacLock™ an improved Mac security kit/table clamp.

- MacPublisher.....\$ 99.95
- Foreign & Bilingual Editions\$129.95
(French, German, Italian, Spanish)
- Imagewriter Carbon Ribbons.....\$ 9.95
- MacPublisher Professional Designs...\$ 39.95
- MacLock (antitheft kit).....\$ 49.95

**BOSTON SOFTWARE PUBLISHERS/ 19 LEDGE HILL RD.
BOSTON, MA 02132
617/327-5775**

Beautiful music for a business computer.

You've waited and waited for truly useful business software for the Macintosh™. But now the wait is over. And you *have* to like the sound of that.

Introducing Quartet from Haba Systems. A fully integrated business application featuring spreadsheet, graphics, data base, and annotating functions for the 128K Macintosh.

Yes, we said *integrated*, and yes, we said *128K*. We thought you'd like the sound of that, too.

For starters, Quartet's incredibly fast spreadsheet contains the most powerful analytical features developed to date. Then add to that our wide selection of charts and graphs that effectively communicate results, a data base with superior sorting capabilities, and our unique annotator (a miniature word processor) which allows you to record information in text regions, and it's plain to see who's really in tune with your needs.

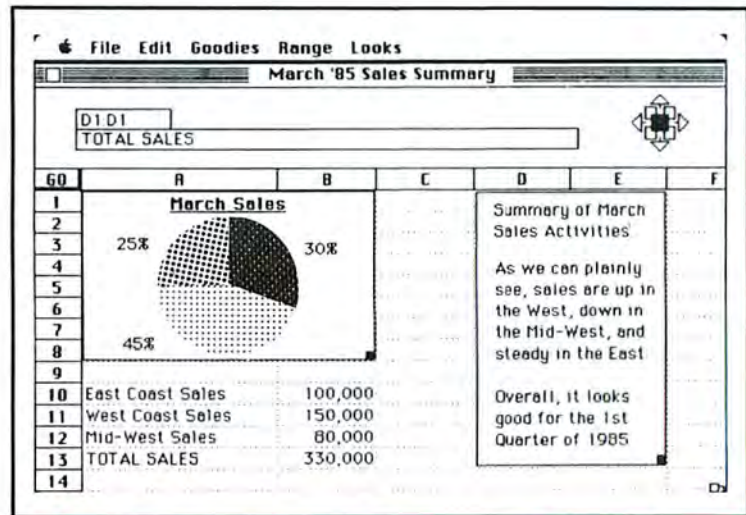

But here's the real tour de force: all four of Quartet's functions - spreadsheet, graphics, data base, and annotator - can be incorporated into the same spreadsheet at the same time. Amazing? Just consider the source.

Quartet from Haba Systems.

It was only a matter of time until you and your Mac began making beautiful business music together.

See Quartet for yourself at the Macworld Expo February 21-23 in San Francisco.



haba systems
Making Apples more tempting than ever.™

15154 Stagg Street, Van Nuys, California 91405-1025, (818) 989-5822

Quartet is a trademark of Haba Systems, Inc. Macintosh is a trademark licensed to Apple Computer, Inc. © 1984 Haba Systems, Inc.

Circle 32 on reader service card

SOFTWARE ADVISOR'S

telasoft

CALL
TOLL
FREE

1-800-MAC-ONLY

We Now Ship

**FEDERAL
EXPRESS \$10**

- Order Line: 1-800-622-6659
- Order Processing & Other Information: 602-224-9345
- Order Line Hours: Mon-Fri 8:30 - 5:30, Saturday 9:00 - 1:00

Address: 1943 East Indian School Road
Suite 194
Phoenix, Arizona 85016



- **No Charge for VISA and Mastercard**
- Shipping and Handling Add \$10.00 for Federal Express or \$5.00 for UPS Ground for Total Order
- Personal and Company Checks Will Delay Shipping 2 weeks
- COO Orders Add 2%
- Call on Purchase Orders
- Prices & Availability Subject to Change Without Notice

CALL FOR A FREE
SUBSCRIPTION TO THE
SOFTWARE ADVISOR NEWSLETTER

SOFTWARE SPECIALS

Multiplan	\$119	Dollars & Sense ...	\$ 84
Chart	\$ 75	TK Solver	\$149
DB Master	\$115	Mac Spell/Write ...	\$ 65
Filevision	\$105	Overvue	\$179

DATA BASE MANAGERS

Fact Finder	\$105
First Base	109
Habadex	109
Main Street Filer	115
MegaFile	115
MegaMerge	75
PFS: File	72
PFS: Report	72
Think Tank	75

SPREAD SHEETS

Chart	See Special
Multiplan	See Special

LANGUAGES

Basic 2.0	\$ 92
Mac Forth (Level I)	92
Mac Forth (Level II)	139
UCSD Pascal Compiler	139

TRAINING

Mastertype	\$ 32
------------------	-------

MONEY MANAGEMENT

Dollars & Sense	See Special
-----------------------	-------------

COMMUNICATIONS

Dow Jones Straight Talk	\$ 49
-------------------------------	-------

ENTERTAINMENT

Cuthroats	\$ 30
Deadline	36
Enchanter	30
Frogger	30
Infidel	30
Mac Slots	49
Millionaire	39
Mouse Stamped	25
Pensate	25
Planetfall	24
Sargon III	32
Sea Stalker	30
Socerer	30
Starcross	36
Suspended	36
Trivia	32
Transylvania	25
Witness	30
Zork I, II, III	30

UTILITIES

Animation Tool Kit	\$ 36
Click Art	32
Copy II Mac	25
Da Vinci	32
Mac Pic #1 & 2	32
Mac The Knife	26

ACCESSORIES

3M Diskettes (10 Pack)	\$ 35
BASF Disks (5 Pack)	18
Diskette Box	22
Dust Cover	10
Microcom MacModem	450
MacTote Carrying Case	69
MacPrinter Carrying Case	45
Maxell Disks (10 Pack)	35
Printer Cover	12
Sony Diskettes (10 Pack)	35
Starter Pack	55
Surge Suppressor	35
Swivel Stand	23
Universal Printer Stand	19

Circle 55 on reader service card

HumanForms™

The Schematic System
for Graphic Body Notation
Anatomically and Proportionally
Correct

The system allows you, using MacPaint™, to select and modify individual body parts and assemble them to create realistic body illustrations. Then insert your HumanForms into notes or documents using Word® or MacWrite® word processing software for accurate referral or professional presentation!

Create a "library" of often used models. Body configurations are limited only by your imagination!

Who will use HumanForms?
Those involved in Medical Instruction & Research, Designers, Martial Arts, Art Directors, Artists, Choreography, Burn Units, Person Abuse Centers, Movement/Massage Therapy, Ergonomics, Education and anyone who needs to reference the human body in their work.

\$59.95

Volume 1: Male and Female,
three views: Front, Back and Side

*Macintosh, MacPaint and MacWrite are registered trademarks of Apple Computer, Inc. Word is a registered trademark of Microsoft Corp.

HumanForms and Realware are registered trademarks of The Reference Corporation.

After March 1st
\$79.95

Send check or money order
for \$59.95 for each volume and
manual, plus \$3.50 for postage and
handling to:

The Reference Corporation

212 Fifth Avenue, Suite 1312
New York, NY, 10010

I've enclosed a personal check
 money order/cashier's check in the amount
of \$_____ For Vol. 1

Please charge my credit account: VISA MasterCard
 American Express. Account No. (all digits please)

Interbank No. _____

(MasterCard only) _____

Expiration date _____

Home telephone # _____

Name of bank _____

Signature _____

(for VISA/MasterCard/Am. Ex. orders only)

Name _____

Company Name _____

Address _____

City _____ State _____ Zip _____

Circle 36 on reader service card

146 February 1985

FootstepS presents...
Book/Software: The Ideal Combination
Software to do your work now.
Books for an in-depth understanding at your leisure.

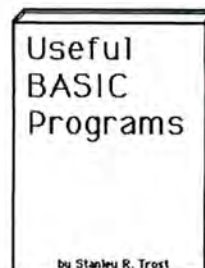

Buy ready-to-run software from us.

Get the books from **SYBEX!**

Science/Engr. Disk: Mean, Standard Deviation, Curve-Fitting, Matrix Operations, Newton equation solving, Integration, and more.

Home/Business Disk: Finances, Investment Analysis, Record Keeping, Data Analysis, Real-estate, and more.

\$35.00 each. Available for Macintosh, Apple II series, or IBM PC®. Licensed by Sybex, Inc. All programs are listable and modifiable.

Massachusetts residents add 3% sales tax. Send Check or Money Order to:
FootstepS, P.O. Box 365, Cambridge, MA 02142
Please specify Macintosh (MS-BASIC I.x), Apple II DOS 3.3 (Applesoft),
or PC-DOS 2.x (BASICA, 64K)
(For information, call 617-494-0910)

*As we all know, these are trademarks of Apple Computer Corporation and International Business Machines Corporation, respectively.
The name Sybex and the Sybex logo are trademarks of Sybex, Inc.

Circle 196 on reader service card



MACINTOSH™ STOCKING STUFFERS

These two great new programs
from CDI will make perfect
Christmas Gifts

HomePak™ . . . 10 Useful Programs for the Home..... **\$39⁰⁰**

- | | |
|---------------------------------|-----------------------------|
| 1. Financial Calculator | 6. Home Inventory Record |
| 2. IRA Benefit Calculator | 7. Stock Record |
| 3. Checkbook Reconciliation | 8. Improved Alarm Clock |
| 4. Banner Maker | 9. New Puzzle |
| 5. Personal Financial Statement | 10. Desk Accessories Editor |

MacOffice™ . . . 10 Useful Programs for the Office..... **\$39⁰⁰**

- | | |
|-------------------------------|--|
| 1. Loan Amortization Schedule | 6. Statistics (mean, median, std. deviation) |
| 2. ACRS Depreciation | 7. Internal Rate of Return |
| 3. Lease vs. Purchase | 8. Bond Yield to Maturity |
| 4. Financial Calculator | 9. Calendar (days between dates, etc.) |
| 5. Scientific Calculator | 10. Desk Accessories Editor |

Be a Saint and put one (or both) of these programs in the Christmas stocking of your favorite MAC user. Just in the Nick of time for that perfect Christmas gift!!!

ORDER TODAY OR SEE YOUR DEALER!!



Creighton Development, Inc. 4931 Birch Street, Newport Beach, CA 92660
(714) 476-1973

TM - Homepak and MacOffice are trademarks of Creighton Development, Inc. Macintosh is a trademark licensed to Apple Computer, Inc.

Circle 95 on reader service card

Circle 64 on reader service card



Introducing MACWORLD

The Macintosh Magazine

**The Exciting New Magazine for
the World's Most Creative Personal
Computer—the *Macintosh***

**At Special Charter Subscriber Rates
Save Up to 63% Off the Newsstand Price**

(when you subscribe for 2 years)

Personal computing took a giant leap into the future when Apple introduced the Macintosh. We've created *Macworld* as your passport into this incredible new realm of computing. Each issue brings you everything you need to explore and get the most out of your Macintosh. From the latest product news to innovative business applications, from amazing graphics to personal productivity tools and games, each issue of *Macworld* is packed with interesting, practical, readable information written by skilled, perceptive writers.

Each month we'll be creating a *Macworld* community; sharing ideas, problems, and creative solutions while we explore the world of Macintosh together.

So why take a chance on missing a single exciting issue? For a limited time only you can subscribe to *Macworld* at special Charter Subscriber rates of only

 **\$19.97 for 1 year (13 issues)**

That's a savings of 33% off the regular \$30 subscription rate and 61% off the newsstand price!

**And you can save even more by subscribing
for 2 years at Special Charter Rates.**

Don't Wait . . . Subscribe Today and Save!



Special Charter Subscription Offer

Save 61% off
the Newsstand Price!

~~\$5.65~~

Newsstand

~~\$81~~

Regular Subscription Rate

\$19.97

Special Charter
Offer

Order Now to Take
Advantage of This
Limited Time Offer!
VISA and MasterCard
Accepted! Call TOLL FREE:
800-247-5470
(in Iowa 800-532-1272)

I ACCEPT! Please send me *Macworld*, the Macintosh magazine. Please send me 12 monthly issues PLUS the special Software Review issue, all for just. \$19.97. I'll save 33% off the regular subscription rate.

- \$19.97 for 1 year (12 monthly issues PLUS the special Software Review issue)
SAVE EVEN MORE!
 \$37.97 for 2 years (26 issues)

Name _____

Company _____

Address _____

City, State, Zip _____

Please allow 6 to 8 weeks for delivery of your first issue. All orders must be prepaid in U.S. funds. Outside the U.S. and Canada rates are \$32.97 per year for surface mail or \$84.97 per year for airmail.

Offer expires September 30, 1985.

JM6A18

I ACCEPT! Please send me *Macworld*, the Macintosh magazine. Please send me 12 monthly issues PLUS the special Software Review issue, all for just. \$19.97. I'll save 33% off the regular subscription rate.

- \$19.97 for 1 year (12 monthly issues PLUS the special Software Review issue)
SAVE EVEN MORE!
 \$37.97 for 2 years (26 issues)

Name _____

Company _____

Address _____

City, State, Zip _____

Please allow 6 to 8 weeks for delivery of your first issue. All orders must be prepaid in U.S. funds. Outside the U.S. and Canada rates are \$32.97 per year for surface mail or \$84.97 per year for airmail.

Offer expires September 30, 1985.

JM6A18

I ACCEPT! Please send me *Macworld*, the Macintosh magazine. Please send me 12 monthly issues PLUS the special Software Review issue, all for just. \$19.97. I'll save 33% off the regular subscription rate.

- \$19.97 for 1 year (12 monthly issues PLUS the special Software Review issue)
SAVE EVEN MORE!
 \$37.97 for 2 years (26 issues)

Name _____

Company _____

Address _____

City, State, Zip _____

Please allow 6 to 8 weeks for delivery of your first issue. All orders must be prepaid in U.S. funds. Outside the U.S. and Canada rates are \$32.97 per year for surface mail or \$84.97 per year for airmail.

Offer expires September 30, 1985.

JM6A18



NO POSTAGE
NECESSARY
IF MAILED IN
UNITED STATES

BUSINESS REPLY CARD
FIRST CLASS PERMIT NO. 79 BERGENFIELD, NJ

POSTAGE WILL BE PAID BY ADDRESSEE

Macworld
Subscription Department
P.O. Box 20300
Bergenfield, New Jersey 07621

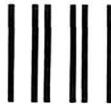

NO POSTAGE
NECESSARY
IF MAILED IN
UNITED STATES

BUSINESS REPLY CARD
FIRST CLASS PERMIT NO. 79 BERGENFIELD, NJ

POSTAGE WILL BE PAID BY ADDRESSEE

Macworld
Subscription Department
P.O. Box 20300
Bergenfield, New Jersey 07621



NO POSTAGE
NECESSARY
IF MAILED IN
UNITED STATES

BUSINESS REPLY CARD
FIRST CLASS PERMIT NO. 79 BERGENFIELD, NJ

POSTAGE WILL BE PAID BY ADDRESSEE

Macworld
Subscription Department
P.O. Box 20300
Bergenfield, New Jersey 07621

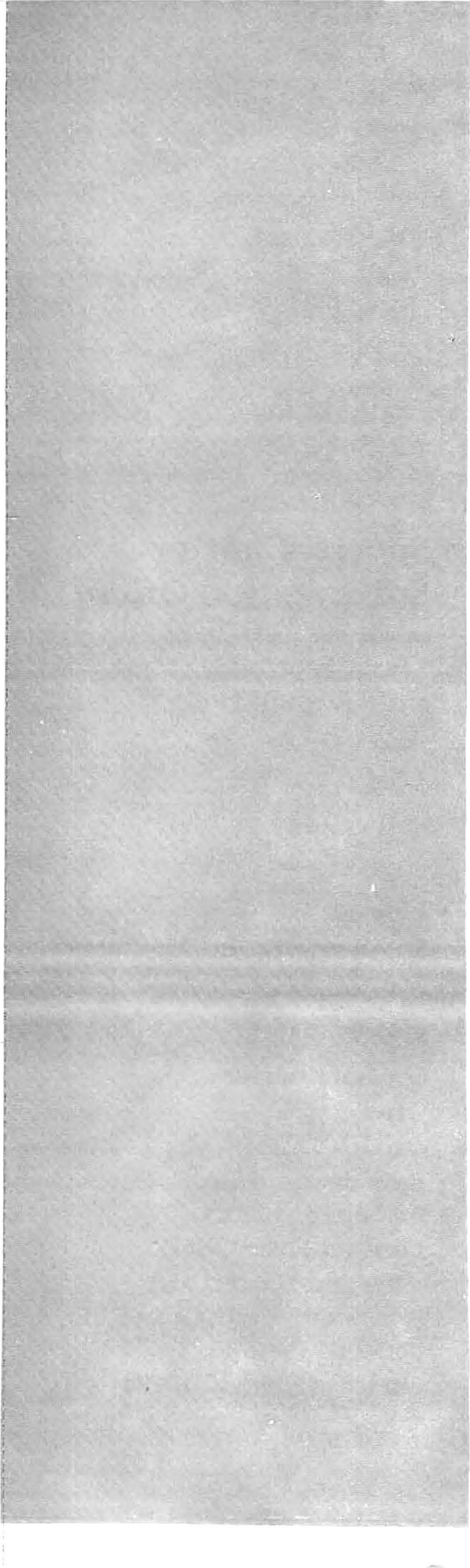

The fastest selling, highest quality case made for the Macintosh Computer.

MacTote.™

PrintTote for
Imagewriter
coming soon!



Now your Macintosh Computer can leave your home or office fully protected and in style.

The **MacTote** computer case is clearly the finest carrying case manufactured especially for your Macintosh Computer, and for a number of easy-to-see reasons:

1. Padded pouch for mouse;
2. Open pouch for manuals or notes;
3. Open, padded pouch for keyboard;
4. Side handle for easy carrying and stability;
5. Padded, Velcro handle (no snaps);
6. Padded, non-slip shoulder strap;
7. Velcro pouch for disks or accessories on side of case;
8. Zippered padded pouch for disk drive;
9. Padded pouch for accessories, modem, cords, etc., and extra padding to protect Macintosh's screen;
10. Reinforced bottom fully supports and distributes weight of Macintosh;
11. Heavy-duty nylon zippers.

Optimum Computer Luggage has extensive experience in making top-of-the-line totes and accessories and

MacTote is the latest in a long line of beautiful and functional luggage. Made



of long-wearing and completely water-resistant Cordura, **MacTote** gives you every feature you'll ever need for carrying your Macintosh and peripherals.

Another attractive feature is **MacTote's** low price, which makes it even easier to pick up and carry away.

Call our 800 number today for the dealer nearest you so you can get a **MacTote** for your Macintosh.

Who says you can't take it with you?

Call (800)447-0300
Or in CA TOLL FREE (800)632-4200.

OPTIMUM
COMPUTER LUGGAGE

*The Finest Quality
Doesn't Have To Cost More.*

9005 Complex Drive
San Diego, CA 92123

Macintosh is a trademark licensed to Apple Computer, Inc.
MacTote is a trademark of Optimum Computer Luggage.
Circle 34 on reader service card

Mac on the Audit Trail

Steve Mann

You may think of an accountant as a green-visored, anemic, bookish type who pores over long columns of numbers far into the night. Let's face it, Errol Flynn never portrayed a swashbuckling accountant, snatching a company from the throes of bankruptcy in the nick of time. Although swashbuckling will probably never be used to describe an accountant, one firm—Peat, Marwick, Mitchell & Co.—is changing the way accountants do business.

In January 1984, Peat Marwick announced that the Macintosh would become an integral part of its auditing practice. Replacing pencils and paper ledger sheets with state-of-the-art microcomputer tools is a radical step for a conservative profession that until now has not automated the audit process.

In the aftermath of the Crash of 1929, Congress created the Securities and Exchange Commission (SEC). One of the SEC's functions is to monitor public stock trading to help guarantee that investors have reliable, accurate information on which to base decisions. The Securities Acts of 1933 and 1934 required that all publicly traded companies file financial statements, accompanied by the formal written opinion of an independent accounting firm, with the SEC.

As a result of that legislation, all companies that are publicly traded in the United States must be audited. When performing an audit, an accounting firm scrutinizes the financial records of a business—whether they are on note cards, ledger sheets, or spreadsheets—and delivers an official "opinion," stating whether the financial statements accurately represent the business's financial condition.

Peat Marwick is one of the largest of the Big Eight—the eight largest accounting partnerships in the world, each having annual revenues ranging from \$200 million to over \$1 billion. The Big Eight accounting companies audit most of the largest corporations in the United States.

7:10 a.m.

Already at work as the sun rises over the bay, an audit team holds a strategy session at the Tampa, Florida, office of Peat, Marwick, Mitchell & Co. Senior manager John Huyett, managing auditor Debra Frank, and supervising manager Brad Boaz (right to left) share information on the Jack Eckerd Corporation, the client on the day's schedule. They discuss the client's internal controls and decide on sampling techniques and other tools needed for an effective audit. Preparation for an audit normally takes several sessions, each lasting a couple hours.

Peat Marwick's Tampa office has 85 people on staff, about 50 of them auditors. The staff uses 28 Macintoshes.



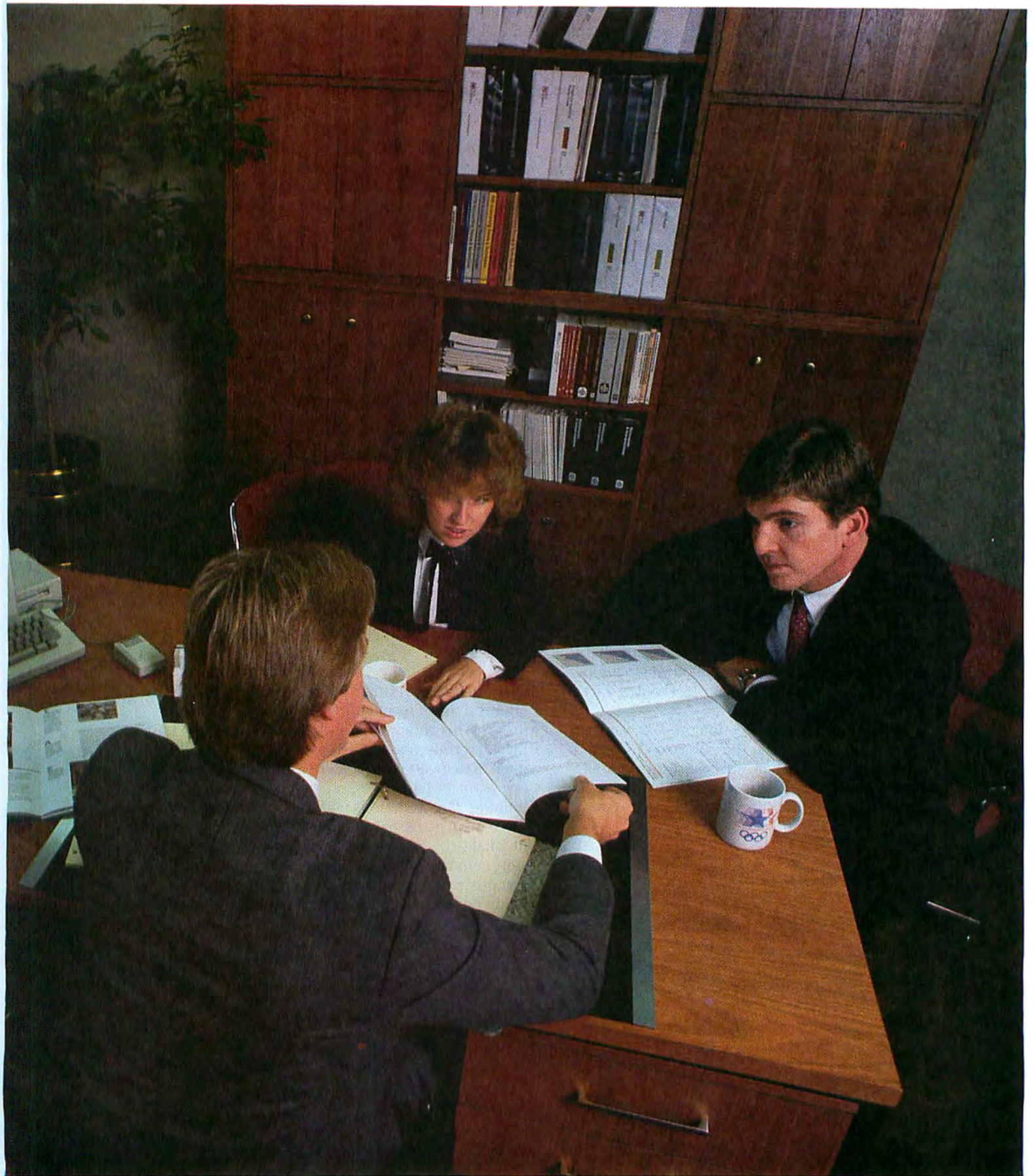

The Automated Audit

As conducting a business becomes more complicated and automated, it's almost inevitable that the auditing process take advantage of technological advances. Productivity, quality, and consistency can all be enhanced with the right computer tools. And because most large companies, and many smaller ones, keep financial records on computers, it is appropriate that auditors examine these records with computers.

In 1980, Peat Marwick's board of directors asked its auditing partners to define the areas of the audit process that could be computerized. In 1981 an internal advisory group identified such areas as audit administration and detailed numerical analysis for automation.

● ● ● ● ● *Peat Marwick initially contacted 28 vendors in search of the perfect audit machine.*

Finding the Right Micro

Because audits are generally conducted at the client's location, the company decided on portable personal computers. Peat Marwick initially contacted 28 vendors in search of the perfect audit machine. In addition to choosing the right hardware, it was important to select a vendor that would be around through the 1980s so that the investment would be worthwhile. The list was narrowed to four: Apple, Hewlett-Packard, IBM, and Xerox.

The next step in the selection process was to determine what each of these companies had planned. Peat Marwick wanted a hardware-software combination that would be useful for several years. It didn't make sense to invest millions of dollars in a system

that would become technologically obsolete in a short time. But none of the available products was perfectly suited to the task at hand.

In 1982 the internal advisory group offered to trade future plans with Apple, Hewlett-Packard, and IBM. IBM declined. Hewlett-Packard and Apple agreed. In May, Peat Marwick decided it had found the right personal computer for the job—the Mac. The user interface, portability, and processing capabilities of the Mac all helped tip the scales in Apple's favor. Behind the scenes, Peat Marwick began working with engineering prototypes of the Mac.

There was still a rough trail ahead. Although the Mac had not yet been released, the company decided to use Apple IIIs in the field while waiting for the Mac. At least one Apple III was installed in each domestic office, and dozens were sent abroad. Each system included proprietary audit software and specific programs from outside developers, such as *Advanced VisiCalc* from VisiCorp. This was only an interim solution, however. The programs later included with the Mac were different from those included with the Apple IIIs.

The Mac was chosen largely because it has an excellent user interface. The firm didn't want to spend exorbitant amounts of money to train auditors. The Mac requires a minimum of initial as well as ongoing training and support.

The Mac's work environment also provides benefits for the clients. The auditor can spend a few minutes with a client explaining the basics of audit software, and then let the client enter much of the required financial data, thereby lowering overall audit costs.

Close on the heels of Apple's formal Macintosh announcement in January 1984, Peat Marwick announced that it would purchase over 4000 Macintoshes. This endeavor is more complicated than buying a few thousand Macs, however. Peat Marwick intends to invest more than \$30 million over the next five years for hardware, software development, and training. This ambitious undertaking encompasses three main goals: to increase staff productivity and audit quality by using personal computers efficiently; to shift mundane clerical tasks from the auditor to the computer; and to enhance the company's image by being on the leading edge of technology.

8:19 a.m.

Have Mac, will travel: Boaz, Huyett, and Frank set out for the offices of the Jack Eckerd Corporation, a major retailer in the Southeast with headquarters in nearby Clearwater. On a typical auditing expedition, a team is equipped with two Macs, a ten-key pad, an Imagewriter with a 15-inch carriage, an external disk drive, and a modem. The team also brings software components of the SeaCas (Systems Evaluation Approach—Computerized Audit Support) system, including Peat Marwick's own Financial Statement Subsystem (FSS), MacWrite, MacTerminal, and Microsoft's Multiplan, Chart, and File.





10:05 a.m.

Part of the audit procedure involves equipment inventory. The Peat Marwick audit team walks through the truck lot with Sam Bass (left), manager of inventory accounting with the Eckerd Corporation.

SeaCas

The centerpiece of Peat Marwick's audit system is SeaCas (Systems Evaluation Approach—Computerized Audit Support), a combination of hardware and proprietary software designed to simplify the auditor's job. According to Mark Miller, former SeaCas coordinator in Peat Marwick's San Francisco office, SeaCas is "Peat Marwick's structured approach to incorporating microcomputer technology into the audit practice."

There's nothing mysterious about SeaCas. An auditor doesn't key in a series of numbers and wait for the machine to render an opinion. "The computer has no judgment; the auditor has the judgment," explains Miller. "Some of the things we do are mechanical or clerical. If the computer can crunch numbers, I can dispense with those mechanics and get to the heart of the matter—the part in which I can exercise my knowledge. You might think of a calculator as a rip saw, the computer as a power saw, and the auditor as a builder."

In its current incarnation for the Macintosh, this particular power saw includes:

- A 128K Macintosh
- The *Financial Statement Subsystem (FSS)*, Peat Marwick's proprietary software
- *Multiplan* and several templates
- Apple's *MacWrite* and *MacTerminal* application programs
- Microsoft's *File* and *Chart* for the Macintosh.

Each of these components is integrated into a methodology designed to relieve auditors of mundane details, such as adding columns of numbers, and allow them to concentrate on the primary purpose of an audit: attesting to the accuracy of the financial statements under scrutiny.

10:52 a.m.

Bass and the audit team in one of the client's warehouses. The Eckerd Corporation owns retail outlets including a chain of drugstores and various video, optical, and department stores. Most of the actual auditing takes place in an office provided on site by the client, where the SeaCas system is set up. A client representative is always on hand to answer questions and respond to comments that come up during the audit.

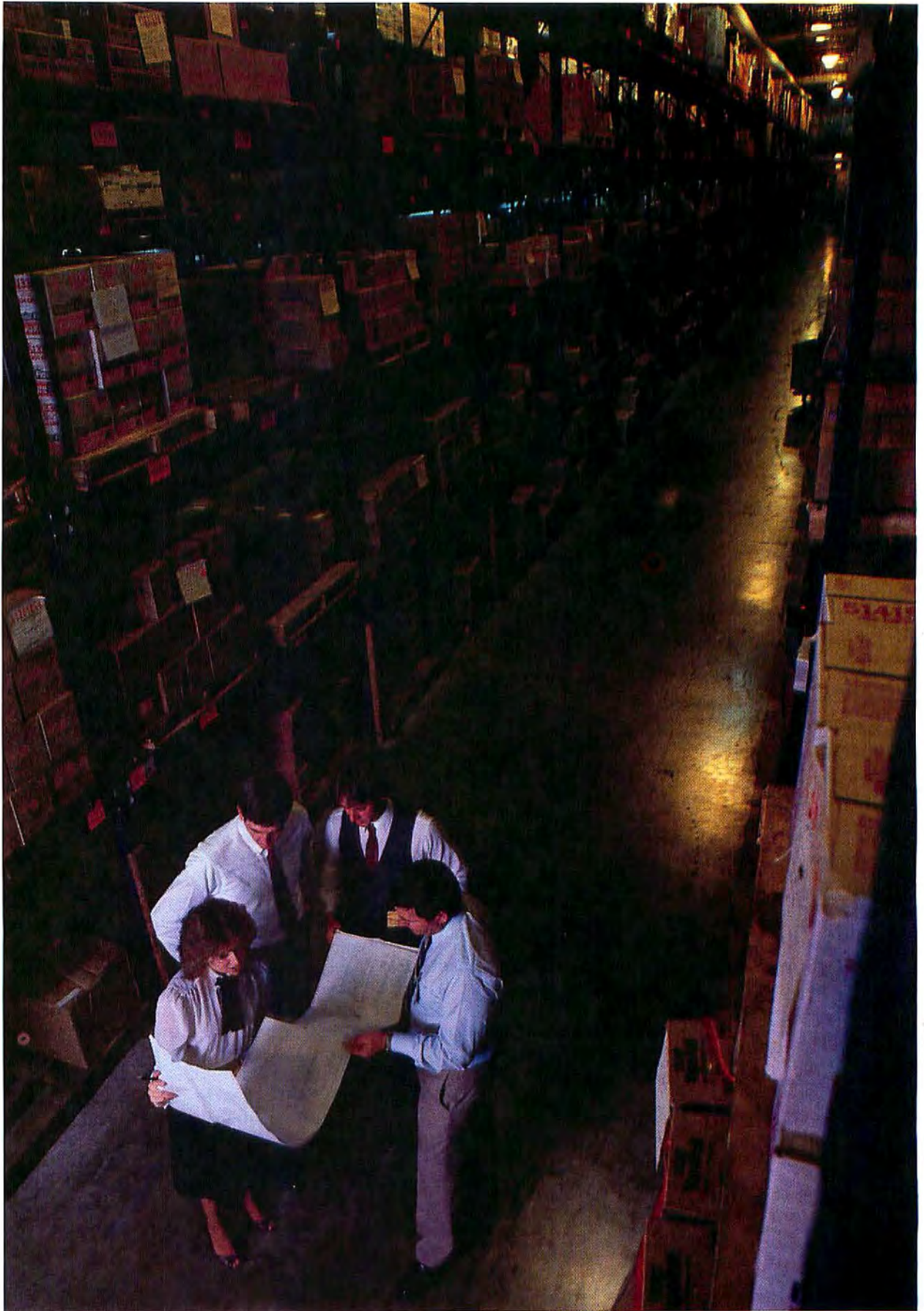

The Financial Statement Subsystem

The *FSS* is probably the most innovative part of SeaCas. With this proprietary program, an auditor can create a complete set of draft financial statements for a client, along with all the supporting detail required to document the derivation of the numbers on those statements. The *FSS* main menu is partitioned into three primary capabilities: entering a general ledger, changing financial statements, and setting up financial statements (see Figure 1).

If the auditor ever has any doubts about using the system, he or she can refer to an on-line help function, available at any time, which can be read by scrolling or topic search.

The auditor enters data in the General Ledger window. *FSS* functions like a specialized spreadsheet. The auditor enters information in each financial statement. Linked to each number on those statements is a set of general ledger accounts and their balances (see

● ● ● ● ● *Using electronic mail for any audit-related documents is both quicker and less expensive than sending printed documents through the postal system.*

Figure 2). *FSS* automatically tells the auditor if the statements are in or out of balance, posts adjustments when required, and prepares printed statements for review. In the past, if an auditor had to make an adjustment, he or she had to create the proper accounting entry and then manually update several financial statements and supporting worksheets to reflect that adjustment. With *FSS*, once the adjustment is entered into the program, all the other tasks are executed automatically.

FSS can store several years of data about a business. Redundant information need be entered only once—the first year that *FSS* is used for that audit. In

subsequent years, only data that has changed need be modified. *FSS* is ideal for creating comparative financial statements covering more than one year, because all the data is readily available.

FSS prepares basic analytical review reports showing year-to-year financial changes. Another important feature of *FSS* is its ability to share financial information with other software, such as *Multiplan*.

Other Software Components

Although *FSS* is the flagship, the other programs are vital components of the SeaCas fleet. *Multiplan* is used for analytical reviews, or calculating ratios from the financial statements using data passed from *FSS*. Ratios can be used to reveal "big picture" aspects of a business. Analytic reviews are most valuable when they are done for successive years; the auditor can quickly determine which components of the business change from year to year. *Multiplan* is also ideal for other types of audit calculations, such as loan payment schedules, depreciation, inventory, and budgeting.

MacWrite can be used for many of the tasks involved in an audit, such as writing letters and formal opinions about financial statements, as well as reports documenting the audit. *Microsoft File* can help keep lists of depreciable assets and other schedules, and *Microsoft Chart* generates graphs to show the relationships between groups of numbers.

Communications

The Peat Marwick auditors use electronic mail and micro-to-mainframe communications. The firm subscribes to an international electronic mail service through International Telephone and Telegraph (ITT) Dialcom. Even before SeaCas was developed, this service was used for a variety of electronic tasks, including on-line special-interest bulletin boards and message transfers. Using *MacTerminal* and a modem, an auditor can generate draft financial statements for a client in San Francisco, for example, and send them for review to a partner in New York. Using electronic mail for any audit-related documents is both quicker and less expensive than sending printed documents through the postal system.

Micro-to-mainframe communications are an integral part of the audit process. For many years, Peat Marwick has used the mainframe-based package S/2190 to automate certain procedures requiring mainframe access, such as selecting specific accounts receivables records for examination purposes.

Before the days of SeaCas, auditors often had to process mainframe jobs in the middle of the night because getting time on a mainframe was often a matter of waiting in line or finding times of lowest usage. Now the auditors can set up an S/2190 job on a Macintosh during normal working hours and send it to the mainframe. The job is still processed at night, but the au-



12:30 p.m.
 Audit team members have a relaxing lunch at a Gulf Coast restaurant. The midday break is an opportunity to assess the progress of the audit and to plan the rest of the workday.

FSS
General Ledger
Journal Entries
*Audit Difference
*Adjusting
*Reclassification
Statement of Changes Analysis Entries
Set-Up:
*Balance Sheet
*Income Statement
*Retained Earnings
*Statement of Changes

Figure 1
 The FSS Main menu, partitioned into the subsystem's three primary capabilities—entering a general ledger, changing financial statements, and setting up financial statements.

File/Print Edit Report Format Report Options Define Options			
Set-Up Balance Sheet			
Balance Sheets December 31, 1983 and 1982			
Assets	1983	1982	
Current assets:	\$ 28,743	12,	
Cash			
Accounts receivable (net allowance for doubtful accounts of \$5,000 in 1983 and \$5,000 in 1982)	103,943	137,	
Inventory	163,006	222,	
Definition Worksheet			
VARIABLE NAME:	ACCOUNTS REC	1983 IS	n Balance
DEFINITION SOURCE:	General Ledger	1982 IS	n Balance
CURRENT SELECTION:	1983	1981 IS	% Not Designated
ACCOUNT	ACCOUNT TITLE	1984 UNADJUSTED BALANCE	1983 ADJUSTED BALANCE
1 1010	Accounts receivable	331,734.00*	108
2 1011	Allowance for doubtful	15,500.00-	

Figure 2
 Setting up a financial statement. Each number on this balance sheet can be linked to a subset of the General Ledger accounts, called the definition worksheet for that number.



2:10 p.m.
Back with their Macs, the Peat Marwick auditors confer with Don Perfetto, controller of the Eckerd Corporation's drugstore subsidiary. Here they discuss the current year's sales figures by region as compared to the previous year's. One member of the team usually keys in data required for the audit, although at times the client provides personnel to do the task.

Auditing a client as large as the Eckerd Corporation can require the skills of as many as six Peat Marwick auditors working for two months, during which the Macs and the rest of the SeaCas system remain on site.



4:18 p.m.
Upon completion of the audit, Frank, Huyett, and Boaz load their equipment into her car. The three-ring binders contain client information necessary to the audit. Because documentation for the SeaCas system is on-line, the Peat Marwick team doesn't have to lug any instruction manuals around.

ditor doesn't have to be there to get the results. He or she can have a good night's sleep and review the results the next morning on a Macintosh.

Communications will certainly play an increased role in Peat Marwick's future. According to Miller, "All the volumes and volumes of professional and firm literature, standards, guidelines, checklists, and questionnaires, for example, will be available on line, so I no longer have to carry that five-pound manual with me everywhere I go."

Another benefit of communications is immediacy. A typical electronic mail communication might read as follows: "I've found a nifty way of doing that depreciation here in the Des Moines office. Would anyone else in the firm like to know how?" Miller calls the process "a competitive advantage—we have the whole firm as a[n on-line] resource."

Training and Administration

With more than 4000 Macintoshes, 8000 auditors, and several hundred locations, instituting a program as comprehensive as SeaCas is a huge, complex task. And the Peat Marwick corporate structure further complicates the endeavor. Each office functions somewhat autonomously, with direction provided, in some cases, by the New York-based executive office.

To guarantee consistency among the various offices, all software and training materials are developed in New York. Each local office has an official SeaCas coordinator, someone who is responsible for communicating with the executive group, providing local training and guidance in using the SeaCas tools, and controlling local security and administration of both hardware and software.

Security is no simple matter. The San Francisco office alone has more than 60 Macs, as well as software and training materials representing an investment of

THE MYSTERY IS SOLVED



UNTIL NOW, professional quality video imaging for the personal computer user was truly a mystery. Your choices ranged from inadequate, toy-like systems ordered through the mail, to bulky, prohibitively priced items designed more for industrial corporations than your home or office.

Enter the MAC PRIVATE EYE™, a system designed specifically with your needs in mind. From the quality of its resolution, to the ease and speed of its operation, the MAC PRIVATE EYE™ is going to make some very devoted friends among graphic artists, engineers, designers, architects, and anyone who works with two and three dimensional images.

In less than a second, this professional quality, user-friendly system, will capture, enhance, and store just about whatever image you'd like on your Macintosh™.

What's even better, is that the MAC PRIVATE EYE™ will be sold through your dealer and backed by professional quality service and warranties. If your dealer isn't stocking the MAC PRIVATE EYE™ yet, (perish the thought), call or write us at:

I/O Video, 222 Third Street
Cambridge, MA 02142 (617) 547-4141.

For a Brochure

See us at MACWORLD EXPOSITION!

Mac
Private eye™

From I/O Video, for computer owners with vision.



MacPak* The finest in protection and useability.

MacBag* They're designed to carry more (modem, 2nd disk drives, numeric keypad, manuals, paper and more) in less space. Compare our protection with any other. No one else is close. Available in assortment of colors.

MacSak* Smaller and lighter, but still more protection.

Call Now

MacPrint•Pak* Reinforced 1" high density foam protects better than any other. Available in standard size carriage and legal size. Call also about the Epsom, Okidata and other PrintPaks. Available in assortment of colors including tan.

MacFreighters & Print•Freighters* The finest on the market. Just superb cases for protection.

MacCovers* 3 choices says it all:

1. Home - thick vinyl leather, attractive and protective.
2. Office - 400 denier nylon. Thin, attractive and protective.

(Both come in 3pc or 5pc sets.)

3. Clear - a neat two piece set that looks good covering all 5 pieces or just 3 pieces.

(Also covers for various accessories such as DaVong*)

Mac•AccessoryPak for those who need to carry accessories and they bought a case where they won't fit.

**WE'VE MADE SOME CHANGES
YOUR GOING TO LOVE**

MacPacks

Carriers, Packs and Covers for the Macintosh*

Call today

1-800-228-7042 for information
Washington residents call
(206) 575-1180

ask for our free brochure or mail to:
643 Industry Dr., Seattle, WA 98188
Circle 28 on reader service card

**"We will match
any mail order
price in this
issue."**

William F. Goller
President, BCP*

We'll support, service and warranty everything we sell and stand behind it 100%. We won't charge you for shipping or handling, nor will we penalize you for using a credit card.



MAC COMPUTERS

Mac 128K CALL Mac 512K CALL

MAC MODEMS

Kensington 300 **99.95** Prometheus Macmodem **399.95**
MicroCom Macmodem 469.96 Novation Macmodem 389.95

MAC PERIPHERALS & ACCESSORIES

Artsci Magicphone 149.95 Apple
Kensington Mac Drive 429.95
Mac Surge 39.95 Mac Pad 89.95
Mac Swivel 25.95 Mac Stand 69.96
Mac Disk 25.95 Mac Case 89.95
Starter Pac **64.95** Disks
Techmar Memorex (10) 39.95
5 mb Rem **1519.95** BASF (5) **19.95**
10 mb Fixed **1519.95** Flip & File 25.95
Iomega Bernoulli
5 mb Rem **1499.95**

MAC PRINTERS DOT MATRIX RS-232

Apple RX-80 F/T 419.95
Imagewriter **499.95** JX-80 Color 699.95
Scribe **239.95** Okidata 92 479.95
Epson Gemini Delta 10 **459.95**
FX-80 **519.95** Gemini Radix 10 629.95
RX-80 329.95

MAC PRINTERS LETTER QUALITY RS 232

Dynax Silver Reed
DX15 XL 21cps 499.95 400 12cps 299.95
DX 25 25cps 739.95 500 14cps 369.95
DX 35 36cps 969.95 550 17cps 439.95
NEC 2010 20cps **799.95** Star Power Type 17cps **359.95**

MAC SOFTWARE

Business & Personal	Educational & Entertainment	
Mac Forth Lev 1	Typing Tutor	39.95
Mac Forth Lev 2	Master Type	39.95
Dow Jones St. Tik.	Mac Fun-Pac	29.95
1st Base	Maccalendar	64.95
Home Accountant	Mac Vegas	49.94
Dollars & Sense	Mac Gammon	39.94
PFS File	Lode Runner	29.95
PFS Report	McPic V.1	39.95
PFS File/Report	McPic V.2	39.95
Mac Speller	Zork I	29.95
Mac Base	Zork II or III	34.95
Main St. Filer	Witness	29.95
Habedex DB	Deadline	39.95
Odesta Helix	Enchanter	34.95
Filevision	Inidel	34.95
TK Solver	Planetfall	29.95
OverVue	Cutthroat	29.95
Solmaker II	Sargon III	34.95
Microsoft	Pensate	27.95
Chart	Transylvania	27.95
File	Xyphus	27.95
Multiplan	Graphic Magician	34.95
Word	Exodus Ultima III	45.95
Mac Basic	Frogger	29.95
Mac Book	Murder by Dozen	29.95
Think Tank	Millionaire	39.95
Megamerge	Barron	44.95
Megafile	Tycoon	44.95
ClickArt Pub	Mac-Slots	54.95
ClickArt	Run for Money	35.95
Mind Probe	Devinci Series	35.95
Comm. Edge	Mirage Trivia	34.95
Sales Edge	Mac the Knife V.1	29.95
Mngt Edge	Mac the Knife V.2	39.95
Negot. Edge		



**BUSINESS
COMPUTERS**
OF PETERBOROUGH

FREE SHIPPING

ORDERS ONLY: 800-845-3003 QUESTIONS 603-924-9406

766 Rt. 101 West • Peterborough, NH 03458

**TaxWizard
STOPS
the competition!**

COMPARE!

Computer-prepared forms:	Tax Wizard '84/'85™	Brand X
Form 1040, 1040A, 1040EZ	yes	
Sch A, B, C, D, E, G, W, SE	yes	
Manual override for unusual tax situations	yes	
4562: Depreciation	yes	
2106: Employee business expense	yes	
2119: Sale of residence	yes	
2441: Child/elderly credit	yes	
3903: Moving Expense	yes	
3468: Investment credit	yes	
4137: Tip income	yes	
4255: Recapture investment credit	yes	
5695: Residential energy credit	yes	
6251: Alternative minimum tax	yes	
Tax-Planning Features		
Auto-linking: change in any form automatically reflected in all others	yes	
Multiple versions on a single disk*	yes	
Multiple users on single disk*	yes	
Ease of Use		
Easy to follow documentation enables new users to get started in minutes	yes	
Complete manual included	yes	
On-screen help	yes	
Help from IRS manual "Instructions for Preparing Form 1040" available on line by line basis*	yes	
Official IRS Forms and Schedules included	yes	
Suggested retail price	\$64.95	
Availability: Macintosh, Apple, IBM, CPM (100+ formats) & Commodore 64	yes	

*Not available on Commodore 64 version due to disk capacity limitation.

**Ask for TaxWizard
at your local retail store.
Don't settle for anything less!**

TaxWizard '84/'85™
by Gamma Productions, Inc.
817 10th Street, Suite 102
Santa Monica, CA 90403

Distributed by Software Resource:

West: 800/851-9010 (CA: 800/851-9009)

East: 800/223-1143 (NJ: 201/390-0999)

South: 800/531-7383 (TX: 713/953-1030)

Nationwide: 800/851-9010

Call for nearest participating computer dealer!

Macintosh is a trademark licensed to Apple Computer, Inc.
Apple, CPM, IBM are registered trademarks of Apple Computer, Inc.,
Digital Research, Inc., and International Business Machines, Corp.

Circle 189 on reader service card

Macworld Gallery

An exhibition of Macintosh graphics

Many people have written asking for details about the Macworld Art Contest, so here they are. The contest is co-sponsored by Macworld and Apple Computer. All original drawings submitted to Macworld Gallery are eligible for the contest, so you can simply send a paper copy of your drawing and a description of how you created it to Macworld Gallery, 555 De Haro St., San Francisco, CA 94107. If your drawing is selected, we will ask you to send a copy of it on disk.

Drawings are viewed each month by a panel of five judges, who choose one winning drawing (\$500 is awarded) and two runners-up (two \$250 prizes are awarded). In addition to the prize-winning drawings, several pieces are exhibited each month in the regular Gallery section. Exhibitors of those drawings are paid \$25 each. Regular Gallery exhibitors retain the rights to their drawings, but the contest-winning drawings become the property of Apple Computer. In November 1985 a grand-prize winner (\$5000) and two runners-up (\$2500 each) will be chosen from among the year's winning drawings.



The Chimney Sweeper

\$500 First Prize

This month's contest is a little unusual; the judges couldn't decide which of the first-prize winner's two drawings they liked better, so we're running both of them.

The Chimney Sweeper

This drawing was inspired by a William Blake poem. I filled the entire screen with black from the paint bucket, then "cut" lines into the background with various white brushes, like a woodcut. I filled the roofs of the houses with a custom pattern. The sky started as a plain gray pattern, which I reworked with the spray can.

*John S. Sunami
Columbus, Ohio*

South Side Settlement House

This drawing was included in an invitation for an open house. I roughed in the building by putting a rectangle over a circle and then erasing unnecessary lines. Then I created the building's striped facade by applying the brick pattern with a few small brushes. I drew one door and one window and then copied them using the lasso and the Option key. I find that *MacPaint* drawings reproduce very well for use in invitations and the like.

*John S. Sunami
Columbus, Ohio*

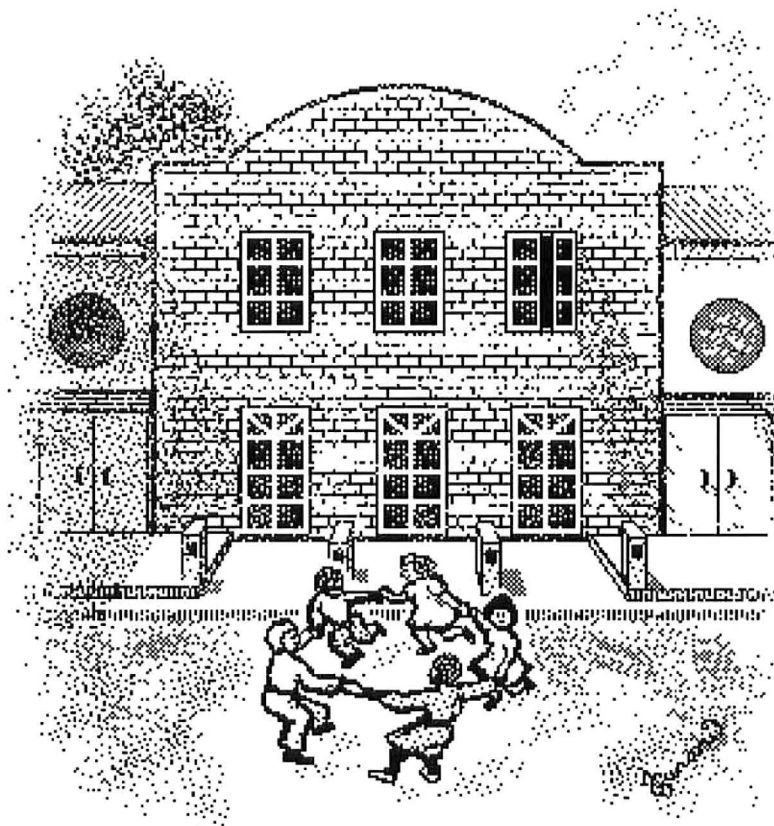

South Side Settlement House

When I Was in London . . .

To create this drawing I began with a small line drawing, done freehand with the pencil, of my reflection in a window. I chose various patterns, some of which I edited, to fill the spaces and add some depth. I filled some areas using the paint bucket, and others by applying a pattern with one of the brushes. Finally, I cut the drawing to the Clipboard, went into *MacWrite*, and pasted the picture into a *MacWrite* document, where I stretched it to fill nearly a full page.

Valenta de Regil
Oakland, California

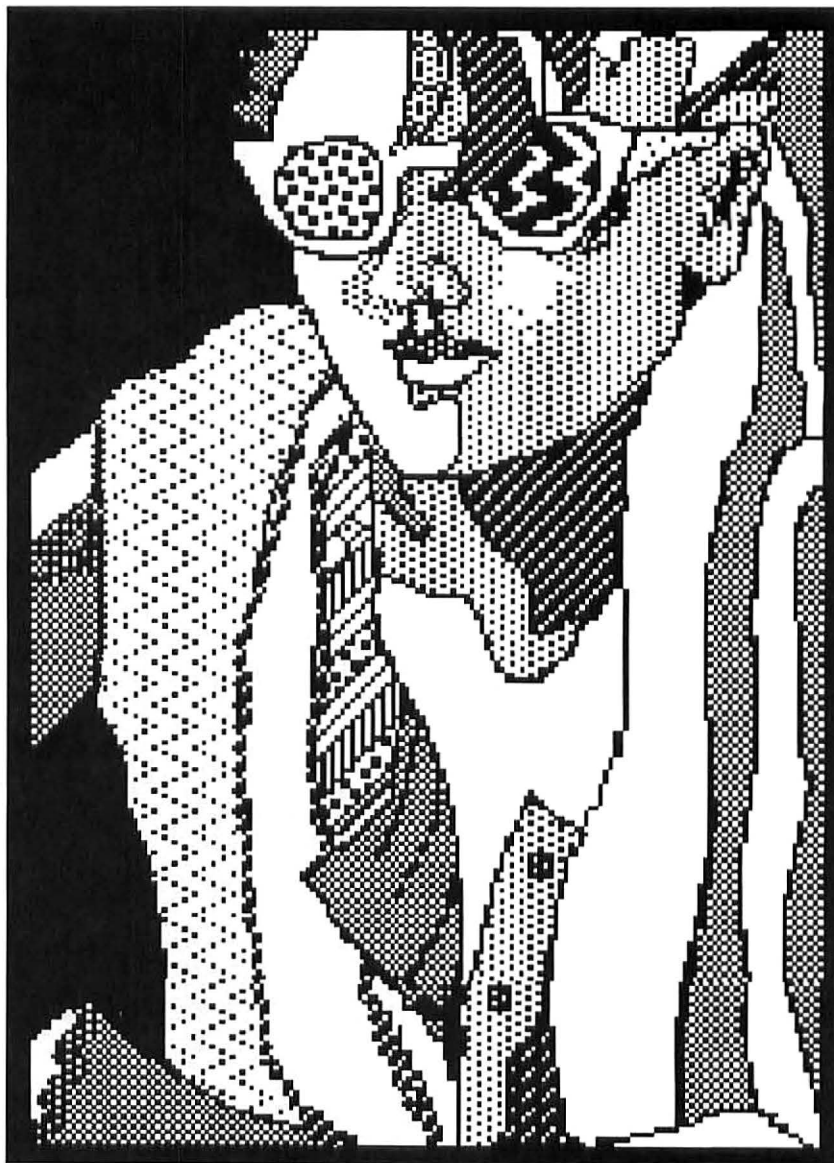

When I Was in London . . .

\$250 Second Prize

Spotted Dog

This is the fourth drawing I've done with *MacPaint*, so I'm still learning how to use the various drawing tools and patterns. First I used the pencil to make rough sketches of the figures. Then I selected a pattern and started filling in spaces with the paint bucket. I added some thick black lines with a paintbrush, sprayed some areas white with the spray can, and did some final editing and erasing. *MacPaint* lends itself well to spontaneity—you can immediately explore unexpected results and can always erase experiments that don't work quite right.

Rudy Autio
Missoula, Montana



Spotted Dog

\$250 Second Prize

Larry

I'm a painter and photographer and have been using computers for several years to produce graphics. While the Macintosh is new to me, I am enthusiastic about its graphics capabilities. This drawing was done from a photograph I took of a friend. I outlined various areas and filled them with patterns from the paint bucket. Once the basic shapes were blocked in, I used the spray can to add some texture and shading. I used Fat-Bits, of course, to work on details and touch up portions of the drawing.

*Jim Alley
Interlochen, Michigan*

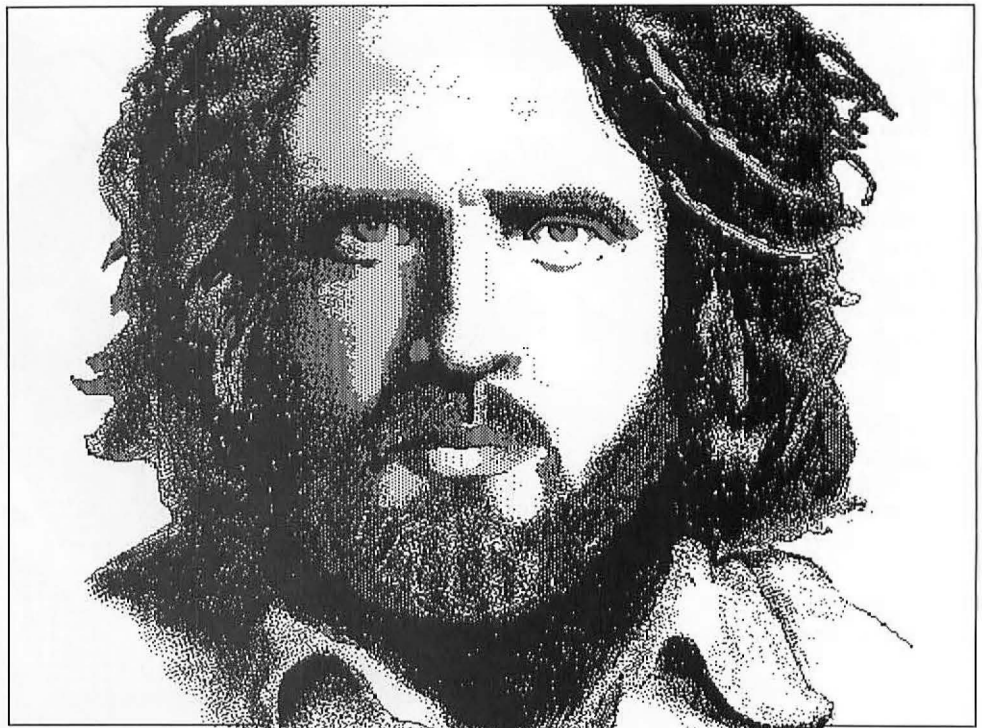

Larry

Morning Exercise

I drew a skeleton in black with the pencil and the small round brush, then made several copies, modified them slightly, and placed them around the screen. Next, I filled the background with gray, using the paint bucket. Then I selected the entire drawing screen by double-clicking on the marquee, and chose Invert from the Edit menu. The skeletons turned white, while the background remained gray. (Although the background pattern was also inverted, it didn't change this particular shade of gray.) As a finishing touch, I drew the shadows with the small round brush in a darker gray.

*Olga Antonova
Cambridge, Massachusetts*

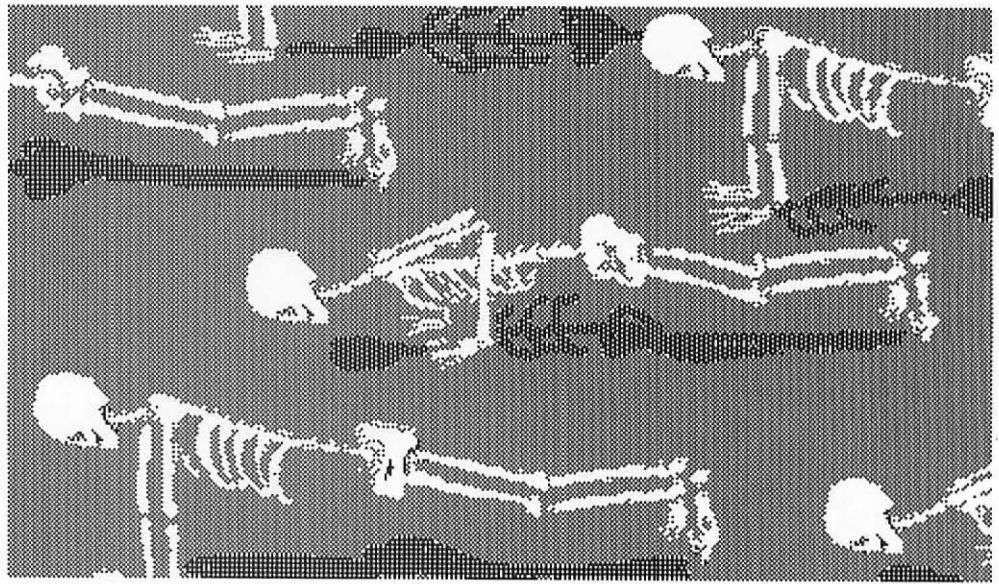

Morning Exercise

Crane/Hiroshima

I use my Mac for designing logos, book covers, letterheads, and all sorts of things. It hasn't replaced my layout pad but instead has added a whole range of capabilities that I can use in combination with an old-fashioned pencil and eraser. I drew the initial origami crane using the straight-line tool, employing a "connect-the-dots" approach. I made three copies of the original, chose Invert from the Edit menu, and moved the black cranes into position. I added shading to the white crane using the square brush and then put in the gray background.

*Al Wasco
Cleveland, Ohio* □



Crane/Hiroshima

Transfer Any Mac Image to T-Shirts

With the **UNDERWARE RIBBON** your Imagewriter makes dozens of iron-on transfers. Print any Macpaint™ image on plain paper, then iron it onto your own T-Shirt. See your Mac dealer or mail \$49.95 (plus \$1.20 sales tax for California residents) to:

UNDERWARE RIBBON™

Diversions, Inc.
1550 Winding Way
Belmont, Ca. 94002
415-591-0660

Circle 164 on reader service card

Don't Be a Sap!

Turn Your Mac into a Money Machine

Now you can buy a single database that contains hundreds of markets for you and your Mac.

Send us \$15 and a disk. We'll send it back full of factsheets that tell you how and where you can sell:

- Business services
- Mac artwork
- Manuscripts
- Programs
- And more

Send it NOW!

607 N. Court, Fairfield, IA 52556

Mac Underground

Circle 160 on reader service card

COMPUTER Tutor's **MacTech**

Vol. 1 No. 2 The Macintosh Programming Journal Nov 84

AT LAST!
A no-nonsense, no fluff Journal devoted to programming **FOR** the Mac, **ON** the Mac!

Let MacTech's editorial board teach you the Macintosh technology of windows, quickdraw, events and resources. We have assembled a team of professionals to uncover and explain Mac's secrets.

ASSEMBLY LAB
by David Smith

C WORKSHOP
by Bob Denny

PASCAL
by Chris Derossi

MACBASIC
by Dave Kelly

MACFORTH
by Joerg Langowski

5 years of experience in PC Computer Education! Your symbol of excellence!

YES! I want to program my Macintosh! Send me a one year subscription. I enclose \$24 US or \$36 Overseas.

MacTech, P.O. Box 846, Placentia, CA 92670

Name _____

Address _____

City _____ State _____ Zip _____

Circle 162 on reader service card

BACKUP PROTECTED SOFTWARE WITH COPY II MAC™

From the team who gave you COPY II PLUS and COPY II PC comes a new complete disk backup utility for your MACINTOSH computer. Features include:

- Bit Copy Program
- Copy Protect/Unprotect
- Make Files Visible/Invisible
- Lock/Unlock Files
- Sector/File Editor
- Copy Files/Disk
- Format/Verify Disks
- Rename File/Disk

Increase the power of your MACINTOSH... use **COPY II MAC**

Available at your local dealer or direct from us.

CENTRAL POINT Software, Inc.

\$39.95 ONLY PLUS \$3.00 SHIPPING/HANDLING

9700 S.W. Capitol Highway, #100/Portland, OR 97219
(503) 244-5782

WELCOME

(Prepayment Required)

This product is provided for the purpose of enabling you to make archival copies only.

Circle 175 on reader service card

Prevent Macintosh Theft!



MacKablit System

Heavy duty 10' steel cable (7 x 19) secures and locks computer, printer, other equipment, up to 4 components. The unique MacKablit system includes 2 brackets that snap into existing slots on the Macintosh keyboard and computer. Additional hardware included for other Mac peripherals (disk drive, printers). The unique MacKablit system utilizes existing security slots on the keyboard and computer and existing screws in other peripheral equipment. The system includes 2 brackets for the security slots plus unique Kablit fasteners for peripherals. Cable passes through Kablit fasteners, preventing removal of screws.

EXCLUSIVE!

Proprietary components (Pat. Pend.) permit only your key to release MacKablit. When ordering multiple units, specify locks to be keyed differently or alike.

Other Kablit systems for IBM, Apple, others.



\$39.95 + \$3.00 shipping/handling

Quantity pricing also available for multiple purchases from schools, institutions, businesses, industrials, etc. Send P.O.



Money back if returned in 30 days. Phone or send check.

Secure-It, Inc.

10 Center Square
East Longmeadow, MA 01028
Phone orders 413-525-7039
Dealer Inquiries Invited

Circle 184 on reader service card

Mouse Pad

Are you being manipulated by your mouse? Does it force you to clean your desk every time you want to use it? If so, you need portable working space. Use a Mouse Pad (pat. pending). Our pad is made from the same high-quality plastic as your Macintosh.™ It's non-skid, no-mar base and protective ridge will help you keep your mouse in its place; use it in your lap, on a tablecloth anywhere. Our pad fits snugly in your carrying case. Don't let a mouse manipulate you. Take Control! Use a Mouse Pad!

Music Character Set

A complete sheet music development package. Contains blank staff sheets for all keys, complete character sets and chord library. For use with Mac Paint.™

Mouse Pad \$12.95 Music Character Set \$24.95

Use our 24-hour order line with your MasterCard or Visa. Personal checks welcome. We pay shipping within continental USA; outside orders add \$3.00 P & H. Satisfaction guaranteed. California residents add 6.5% tax. Macintosh & Mac Paint are registered trademarks of Apple Computers, Inc.



South Bay Software

Box 969 Millbrae, CA 94030 (415) 579-5455

Circle 121 on reader service card

**MACINTOSH OWNERS!
CREATE YOUR OWN DISASTER
WITH . . .**

Macintosh Photo Album #1

Only \$49.95 for your Macintosh disk and complete instruction manual. Instant Visa/MC orders call (24 hrs.): (415) 493-9500
The PERFECT computer gift!



ORDER TODAY!



GRAPHICS OF INCREDIBLE RESOLUTION!!
People, buildings, cars, animals, athletes, party items, landscapes and more. Enlarge, reduce, copy, rotate, or combine MACINSHOTS images for your notices, invitations, cards, and announcements. More than 100 TRUE PHOTOGRAPHIC IMAGES in MacPaint files ready for use on your Macintosh™

Clip this ad and mail today to: Design Loft Inc., Box 1650, Palo Alto, CA 94302. Enclose your check for \$49.95 plus \$5.00 shipping and handling. (CA residents add \$3.25 sales tax.) Be sure to include your name, address and zip code.

Macintosh™ is a trademark licensed to Apple Computer, Inc. MacPaint™ is a trademark of Apple.

Circle 126 on reader service card

Is Your Mac Naked ?

Protect Your Mac With Quality, Custom-Fit, Fabric DUST COVERS

In Tan - Navy - Royal - Gray - Cherry - Chocolate

- Professional Appearance.
- Unlike plastic covers, ours allow heat from equipment to flow thru fabric.
- Machine Wash & Dry.
- Custom Design/Perfect Fit.
- All Fabric. Won't crack or dry out with age.

(Dealer Inquiries Welcome)

3 pc. set includes: Mac, Keyboard & Imagewriter \$ 35.00

Name _____
Address _____
City _____ State _____ Zip _____
Telephone _____ Color _____

Monogram(\$3) _____ Ext. Drive(\$5) _____ Num. Kypd.(\$3) _____
*MC/VISA# _____ Exp. Date _____

(Check, M.O., C.O.D., VISA/MC*) Wis. Residents: Add 5% Tax
Call (414) 476-1584 OR Mail Form and Pymt. to:
CO-DU-CO • 5920A W. St. Paul Ave. • Milwaukee, WI 53213

Circle 62 on reader service card

NOW SHIPPING!!

HIPPO-C™ Level 1

- A friendly, powerful C environment which allows you to quickly edit, compile, link, and execute C programs on a standard 128K single-drive Macintosh™. Produces "double-clickable" applications.
- Comes with an editor, compiler, linker, symbolic debugger, C library, on-line C tutorial, and a shell command processor. The compiler follows the Kernighan and Ritchie C definition, except for floating point. Allows approximately 64K for user programs and data. Provides convenient access to over 380 Macintosh Toolbox and QuickDraw routines. All software is included - nothing else to buy.
- Documentation (includes information on Hippo-C and selected Toolbox and QuickDraw routines) and sample programs.
- \$149.95

HIPPOTAMUS™
SOFTWARE
1250 Oakmead Parkway Suite 210
Sunnyvale, CA 94086
(408) 730-2601

Institutional and dealer inquiries welcome. We accept VISA, Mastercard, cashier's checks, money orders, and personal checks (personal checks take 2 weeks to clear). California residents add local sales tax. Please include \$10 for shipping and handling. Macintosh is a trademark of Apple Computer, Inc. Hippo-C is a trademark of Hippopotamus Software. Please allow 1-2 weeks for delivery. Price, availability, and specifications subject to change without notice.

Circle 40 on reader service card

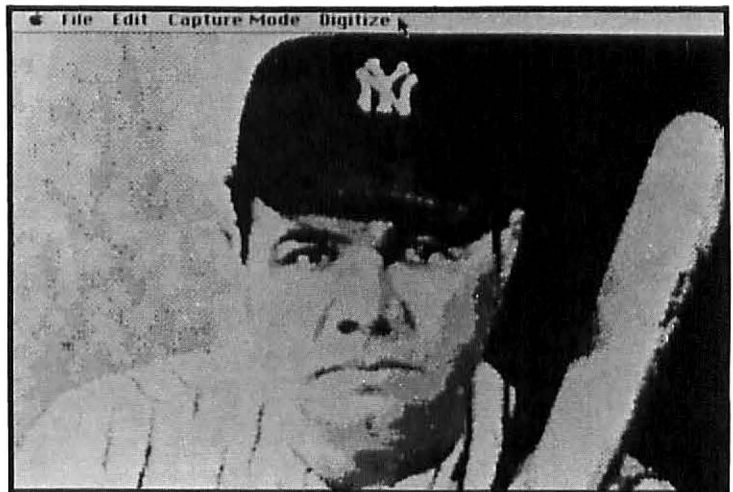

THE MICRO-IMAGER™ VIDEO DIGITIZING SYSTEM CAPTURE/STORE/PRINT

Captures any image for transfer into your Macintosh. You can edit with MacPaint™, store, retrieve and print the image at will.

Two capture modes: two-shade for line drawings and diagrams and six-shade for pictures and portraits.

Call or write **Servidyne® Systems, Inc.**
• 1735 DeFoor Place N.W. • Box 93846 • Atlanta, GA 30377 • 404/352-2050

MacPaint™ is a trademark of Apple Computer, Inc. Macintosh is a trademark licensed to Apple Computer, Inc.

Circle 102 on reader service card

Graphics

For your Macintosh
with Macpaint/Macwrite

- 1 Superfonts:** Fresh faces for your font library. Typefaces that finally allow you the creative capabilities you've been waiting for and the professional quality you demand. Sixteen distinctive typefaces all on one affordable disk, designed for any Macintosh* application that allows you to select fonts. **Only \$29.95**

BABY TEETH BROADWAY City Firenze
Futura GALLIA Honda IVY LEAGUE OPEN
MICROGRAMMA Orbit Parisian PEIGNOT
Playbill RELIEF STENCIL Woodstock

- 2 Presentations:** The kind of graphics you thought only the pros could create are now available for you and your Macintosh*. This disk, designed to work with Macwrite* and Macpaint* provides you with a multitude of borders, textures and symbols that allow you to create unique, professional graphics that will get noticed. For only **\$29.95**. Presentations is the ideal complement to Superfonts.



Personal checks, VISA and MasterCard welcomed. Please add \$2.00 per disk for shipping and handling.

SOFTWARE APPLE-CATIONS

11510 Alejandro • Boise, ID 83709 • (208) 322-8910

*Macintosh, Macpaint and Macwrite are trademarks licensed to Apple Computer, Inc.

Circle 123 on reader service card

AVAILABLE NOW! IEEE 488 Bus Control for your Macintosh*

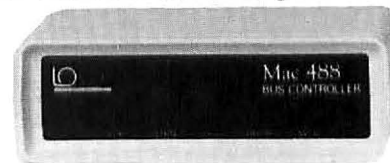

The **Mac488™** provides full IEEE 488 bus capability, including controller, talker, and listener functions. Commands received from the Macintosh serial port are converted by the Mac488 into IEEE bus protocol. Both the Mac488 and a printer can be installed simultaneously, without special adapters.

- High-level commands, similar to the Hewlett Packard 85 — ENTER, OUTPUT, REMOTE, CLEAR, TRIGGER, . . .
- Advanced capabilities, including Pass Control, Receive Control, Secondary Addressing, Serial Poll, and Parallel Poll.
- Driver routines for available languages, including BASIC.
- Also available for Lisa, Apple II, IIe, & IIc*.
- \$595⁰⁰ complete. *Trademark of Apple Computer, Inc.

IOtech

IOtech, Inc.
P. O. Box 21204
Cleveland, Ohio 44121
(216) 321-0609

Circle 73 on reader service card

Professional 3.5" Duplication

**State of the Art Protection Schemes
One Day Turnaround - Low Pricing
100% Satisfaction Guarantee**

Echo is one of the largest duplication houses on the East Coast. We specialize in copying and protecting all 3.5" and 5.25" formats. Our **full service** facilities can provide labels and custom sleeves, and do all of your packaging and mailing. Our prices are the very best!

Wholesale Blank Disks for Sale

We offer first quality brand name disks which we buy in bulk quantities at wholesale prices. Minimum order is 100 disks. All orders shipped the day received.

Prices for 3.5" disks are \$3 each or less, but call for the details. We also carry 5.25" disks of all types, and prices start at \$1 each in lots of 100. We carry: **Maxell, 3M, BASF, Nashua, Centech, Athana.**

To place an order or get further information, call us at **800-441-9374, X1441 or 215-363-2400 in PA.** We accept VISA and MC, and can ship overnight or UPS.



DATA SERVICES, INC.
Marsh Creek Corp Center
Lionville, Pennsylvania 19353

Circle 193 on reader service card

3 classic games of skill for the MACINTOSH
All on TRIPLE PLAY GAME DISK NUMBER ONE

Games the whole family can enjoy

- + **BACKGAMMON**—multiple options and skill levels, to encourage the novice and challenge the expert
- + **MANCALA** (pits & stones)—oldest known two-player strategy game
- + **DEDUCE**—thirty variations of an ancient "guessing" game



+3 chances to compete for
\$4000 in prizes in the
**BACKGAMMON
TRIPLE PLAY-OFF**

Details are on the disk

On sale now for only \$39.50
Money back if not delighted

Orders accepted by check, VISA or MasterCard



PO Box 6354 EE
Lafayette, IN 47903
317+742-5369

Or order through **3rd Base™** Software Registry
Div. of STEL Enterprises—modem 317+423-1010

Circle 122 on reader service card

We challenge minds.



MacEdge.

The most flexible educational software package ever invented. Designed as a "multi-level" package that focuses in on two of the most fundamental aspects of learning—**math and reading.** The math section has everything from counting and addition up through division. The reading portion contains phonetics, contractions, synonyms, antonyms and even more.

8 individual programs for the unbelievably low price of \$49!!
And the best part? It's available now!
3 day delivery!

Mind Over Mac.

An absolutely amazing value for the price. Five complete entertainment programs all wrapped up into one. Included in this "all-in-one" disk are **Master-Code, Destroyer, On-the-Contrary, Third Dimension and Trivial Intrigue.** Each one is completely tailored to the Macintosh environment; enhanced graphics, synthesized sound, mouse control, icons, etc.

Five mind-challenging, thinking games designed for the whole family. Also only \$49. And available right now!!!

THINK Educational Software ...

16 MARKET ST. / P.O. BOX 466
POTSDAM, N.Y. 13676
ORDERS: 315-265-2666 or 315-265-5636

Circle 10 on reader service card

NOW 2 SIZES! THE PRINTER STAND™

80 Column & 132 Column

- ELEVATES & TILTS PRINTER TO A 45° ANGLE FOR EASY READABILITY.
- SAVES DESK SPACE
- PAPER EASILY FEEDS FROM UNDERNEATH; ELIMINATES PRINTOUT CLUTTER. (FANFOLD IN FRONT OR BACK.)
- SOLID, HAND-FINISHED HARDWOODS IN WALNUT, LIGHT OR DARK POPLAR. IMMEDIATE DELIVERY

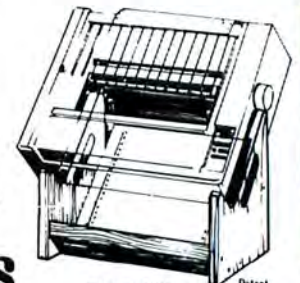

SYNERGY PRODUCTS

(812) 897-5351

UNCONDITIONALLY GUARANTEED Patent Pending

- 80-Col. Stand \$44⁹⁵ plus \$2 postage. MW
 132-Col. Stand \$49⁹⁵ plus \$2 postage.

Name _____

Address _____

City _____ State _____ Zip _____

Payment enclosed — Charge my Visa MasterCard Am. Ex. Account No. _____ Exp. Date ____/____/____

LT. POPLAR DARK POPLAR WALNUT

MAIL TO: SYNERGY PRODUCTS P.O. BOX 485, BOONVILLE, IN 47601

Circle 135 on reader service card

Statistics

The popular **Number Cruncher Statistical System™** is now available for the Macintosh™

Procedures Include:
 Multiple & Stepwise Regression. Correlation. Oneway and twoway ANOVA. Histograms. Univariate Stats. Cross Tabulation. T-Tests. Nonparametrics. Transformations. Plots.

Introductory Price: \$149.95

Dr. Jerry L. Hintze
 NCSS
 865 East 400 North
 Kaysville, Utah, 84037
 1-801-546-0445

Circle 197 on reader service card



12 Foot Macintosh Keyboard Cable

trouble free replacement for the frustrating original short cord

YOUR AFFORDABLE SOFTWARE CO.
 1525 N. Elston
 Chicago, IL
 60622

\$995
Postpaid

Circle 188 on reader service card

Improve your trading with . . .

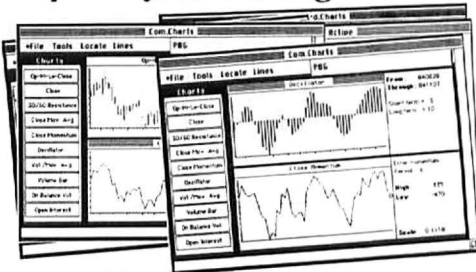

Profit Stalker™

Technical analysis for the Macintosh! Profit Stalker generates crisp, clear, charts from a relational data base of stock and commodity prices. Includes daily prices, trend lines, moving averages, oscillators, volume line and bar, on-balance volume, open interest, retracement levels, daily most active, M1, Fed funds, discount rate, weekly DJIA, and more!

Furnished with sample stock and commodity files, and other market information so you can go right to work. Two disks, fully illustrated manual. Works with 128K Mac, 512K Mac, Lisa with Macworks. Requires Microsoft BASIC 2.0 (a version that works with BASIC 1.0 is available if desired). \$150

California residents add 6% tax. Add \$3 for postage and handling. Specify system and BASIC version. Send check or money order to:

Button•down Software

P.O. Box 19493 San Diego, CA 92119
 619/234-0236

Circle 163 on reader service card

PRESENTING THE MEGAMAX C COMPILER

FEATURING:

- IN-LINE ASSEMBLY • ONE PASS COMPILATION • SUPPORT OF DYNAMIC OVERLAYS • FULL ACCESS OF MACINTOSH TOOLBOX ROUTINES • AND MUCH MORE . . .
- DEVELOPMENT SYSTEM PACKAGE INCLUDES: FULL-SCALE IMPLEMENTATION (K&S) C COMPILER • THE STANDARD C LIBRARY • ROM ROUTINES LIBRARY • LINKER • LIBRARIAN AND DOCUMENTATION . . .

\$299.95

DEALER AND USER GROUP INQUIRES INVITED
 FOR MORE INFORMATION OR TO ORDER CALL
 OR WRITE: **Megamax, Inc.** BOX 6016,
 WACO, TX 76706 (214) 987-4931

VISA, MC, AMER. EXP. ACCEPTED
 Texas Residents Include Applicable Sales Tax.
 MACINTOSH IS A REGISTERED TRADEMARK OF APPLE COMPUTER INC.

Circle 109 on reader service card



RandM Software

PRESENTS

Macintosh

CUSTOM STARTUP SCREENS

Now have a startup screen that expresses the real you!

Do you want your original artwork or company logo to be the first thing you, your clients, employees, or friends see when you turn on your Macintosh?

If you can create a MacPaint picture (and who can't?), we can turn it into a startup screen for you for \$30 or less.

For information on this service, write to:

RandM Software

167 Prestwick Ct. • Vallejo, CA 94591

Circle 182 on reader service card

What is Where?

MacBriefs™

Monthly Digest for Macintosh™ Enthusiasts

Covers the World of Macintosh™

Providing Abstracts of recent magazine, trade, newspaper, and newsletter articles to keep you current quickly from ~~anywhere~~

to **Mos Eisley** • Original Reviews and Editorials on Mac Culture

A Resource for Modern Times

+ Mac Discount Mail Order

Introductory Charter Subscription
 Regular \$36/year **714/ 841-1771**
NOW ONLY \$18

To **MacBriefs™**  
 PO Box 2178, Huntington Beach, CA 92647

YES! I want to be a charter subscriber!
 \$18 Special for 12 monthly issues
 + Discount Macware for subscribers.
 \$3 for current issue postpaid.

name _____
 address _____
 city _____ state _____
 zip _____ phone(____) _____
 I use Mac for: _____
 Letters welcome! Check/MO
 Visa Master Card ExpDate _____
 Card No. _____
 Signature _____

Circle 195 on reader service card

Product Index

- | Reader Service Number | Reader Service Number | Reader Service Number | Reader Service Number |
|---------------------------------------|---|--|---|
| ■ Software | | | |
| Business | | | |
| 64 Creighton Development, Inc., 147 | 31 Mark of the Unicorn, 92 | 189 Gamma Productions, Inc., 163 | Disks |
| 95 Creighton Development, Inc., 147 | 127 Priority Software, Inc., 29 | — Hayden Software Company, 116 | 193 Echo Data Services, 173 |
| 32 Habas Systems, Inc., 145 | 122 Triple Play, 173 | 8 Intermatrix, Inc., 40-41 | Miscellaneous |
| 8 Intermatrix, Inc., 40-41 | 42 Videx, Inc., 33 | 31 Mark of the Unicorn, 92 | 110 Assimilation Process, 18-19 |
| 86 Megahaus, 51 | Financial | — Microsoft, 6-7 | 62 CO-DU-CO, 171 |
| 88 Megahaus, 55 | 163 Button-Down Software, 174 | 117 Monogram, 56 | 202 Computer Alternatives, Inc., 176 |
| — Microsoft, 6-7 | 190 Digital Etc. Software Products, 102 | 181 State of the Art, 105 | 178 Frontrunner Computer Industries, 22 |
| 42 Videx, Inc., 33 | 169 Future Design Software, 130 | 183 Warner Software, Inc., 104 | 11 Kensington Microware, 20 |
| 183 Warner Software, Inc., 104 | 189 Gamma Productions, Inc., 163 | Word Processing/Spelling Checkers | — MicroRain Corp., IFC |
| Communications | 191 Interlobal Systems, Inc., 142 | 110 Assimilation Process, 18-19 | 184 Secure-It, Inc., 171 |
| 69 Dow Jones, 14 | 117 Monogram, 56 | — Hayden Software Company, 119 | 177 Systems Control, 93 |
| 73 I O Tech, 174 | 197 Number Cruncher Stat-System, 174 | ■ Hardware | 188 Your Affordable Software Co., 174 |
| 203 Mycroft Labs, 54 | 124 Peachtree Software, 31 | Digitizers | |
| 205 Touchstone Corporation, 67 | 49 RealData, Inc., 130 | 200 I/O Video, Inc., 161 | Events |
| Data Management | 186 SoftWeave Co., 52 | 102 Servidyne Systems, Inc., 172 | 174 Macworld Exposition, 134-135 |
| 46 Brock Software Products, 42 | Graphics | 167 Thunderware, Inc., 30 | Mail Order |
| 66 Computer Software Design, 68-69 | 204 Ann Arbor Softworks, 103 | Hard Disks | 33 The Bottom Linè, 24 |
| 87 Megahaus, 53 | 93 Axlon, Inc., 137 | 206 Corvus Systems, Inc., 5 | — Business Computers of Peterborough, 163 |
| 114 Forethought, Inc., 61 | 199 Boston Software Publishers, 144 | 176 General Computer, 90-91 | 98 Compuclassics, 143 |
| — Hayden Software Company, 118 | 165 Casady Company, 59 | 171 Iomega Corporation, 38 | 195 Macbriefs Digest, 174 |
| 8 Intermatrix, Inc., 40-41 | 126 Design Loft, Inc., 171 | 24 Micro-Design, 25 | 4 MacConnection, 80-83 |
| 125 Layered, Inc., 12-13 | 88 Megahaus, 55 | 132 Sunol Systems, 133 | 160 Mac Underground, 170 |
| 88 Megahaus, 53 | 97 Mesa Graphics, 98 | 14 Tecmar, 1, BC | 3 Micro Flash Computer Systems, Inc., 99 |
| 13 Odesta, 26-27 | — Microsoft, 6-7 | Miscellaneous | 4 PC Connection, 80-83 |
| 38 Organizational Software Corp., 39 | 36 The Reference Corporation, 146 | 73 I O Tech, Inc., 172 | 45 PC Network, 131 |
| 77 ProVUE Development Corp., 8 | 123 Software Apple-Cations, 172 | 140 Mentaauris, 60 | 172 Qubie', 23 |
| 94 SoftDesign, IBC | Languages/Development Systems | — MicroRain Corp., IFC | 55 Telasoft, 146 |
| — Software Publishing Corporation, 94 | 56 ExperTelligence, Inc., 64 | Modems | Services |
| 54 Telos Software Products, 89 | 40 Hippopotamus Software, 172 | 78 Kensington Microware, 20 | 193 Echo Data Services, 173 |
| Educational | 112 Manx Software Systems, 10 | 72 Microcom, Inc., 101 | 107 International Apple Core, 162 |
| 93 Axlon, Inc., 137 | 109 Megamax, Inc., 174 | Printers/Printer Accessories | 162 MacTech, 170 |
| 144 Forethought, Inc., 136 | — Microsoft, 11 | 110 Assimilation Process, 18-19 | 182 RandM Software, 174 |
| 74 Palantir Software, 132 | 84 SofTech Microsystems, Inc., 62 | 64 Creighton Development, Inc., 63 | 39 Replico Technologies, 130 |
| 198 Simon & Schuster, Inc., 100 | 187 Tardis Software, Inc., 64 | 164 Diversions, Inc., 170 | Books |
| 10 Think Educational Software, 173 | Miscellaneous | 142 NEC, 16 | — Microsoft Press, 17 |
| Entertainment/Strategy | 199 Boston Software Publishers, 144 | 135 Synergy Products, 173 | 9 Hayden Publishing, 28 |
| 93 Axlon, Inc., 137 | 175 Central Point Software, 170 | ■ Accessories | |
| 138 Blue Chip Software, Inc., 65 | 89 Computer Identities, 121 | Carrying Cases | |
| — Hayden Software Company, 116, 117 | 196 FootstepS, 146 | 28 MacPacks, 163 | |
| | 50 Living Videotext, 43 | — MicroRain Corp., IFC | |
| | 79 Software Arts, Inc., 78 | 34 Optimum Computer Luggage, 149 | |
| | 121 South Bay Software, 171 | 172 Qubie', 23 | |
| | Personal Business/Home | | |
| | 64 Creighton Development, Inc., 147 | | |
| | 95 Creighton Development, Inc., 147 | | |

Advertiser Index

<p>Reader Service Number</p> <p>204 Ann Arbor Softworks, 103</p> <p>110 Assimilation Process, 18-19</p> <p>93 Axlon, Inc., 137</p> <p>138 Blue Chip Software, Inc., 65</p> <p>199 Boston Software Publishers, 144</p> <p>33 The Bottom Line, 24</p> <p>46 Brock Software Products, 42</p> <p>— Business Computers of Peterborough, 163</p> <p>163 Button-Down Software, 174</p> <p>165 Casady Company, 59</p> <p>175 Central Point Software, 170</p> <p>62 CO-DU-CO, 171</p> <p>98 Compuclassics, 143</p> <p>202 Computer Alternatives, Inc., 176</p> <p>89 Computer Identities, 121</p>	<p>Reader Service Number</p> <p>66 Computer Software Design, 68-69</p> <p>206 Corvus Systems, Inc., 5</p> <p>64 Creighton Development, Inc., 63, 147</p> <p>95 Creighton Development, Inc., 120, 147</p> <p>126 Design Loft, Inc., 171</p> <p>190 Digital Etc. Software Products, 102</p> <p>164 Diversions, Inc., 170</p> <p>69 Dow Jones, 14</p> <p>193 Echo Data Services, 173</p> <p>56 ExperTelligence, 64</p> <p>196 FootstepS, 146</p> <p>114 Forethought, Inc., 61</p> <p>144 Forethought, Inc., 136</p>	<p>Reader Service Number</p> <p>178 Frontrunner Computer Industries, 22</p> <p>169 Future Design Software, 130</p> <p>189 Gamma Productions, Inc., 163</p> <p>176 General Computer, 90-91</p> <p>32 Haba Systems, Inc., 145</p> <p>9 Hayden Publishing, 28</p> <p>— Hayden Software Company, 116, 117, 118, 119</p> <p>40 Hippopotamus Software, 172</p> <p>191 Interlobal System, Inc., 142</p> <p>8 Intermatrix, Inc., 40-41</p> <p>107 International Apple Core, 162</p> <p>171 Iomega Corporation, 38</p> <p>73 I O Tech, Inc., 172</p> <p>200 I/O Video, Inc., 161</p> <p>11 Kensington Microware, 20</p> <p>125 Layered, Inc., 12-13</p> <p>50 Living Videotext, 43</p> <p>195 Macbriefs Digest, 174</p> <p>4 MacConnection, 80-83</p> <p>28 MacPacks, 163</p> <p>162 MacTech, 170</p> <p>160 Mac Underground, 170</p> <p>174 Macworld Exposition, 134-135</p> <p>112 Manx Software Systems, 10</p> <p>31 Mark of the Unicorn, 92</p> <p>86 Megahaus, 51</p> <p>87 Megahaus, 53</p> <p>88 Megahaus, 55</p> <p>109 Megamax, Inc., 174</p> <p>140 Mentauris, 60</p> <p>97 Mesa Graphics, 98</p> <p>72 Microcom, Inc., 101</p> <p>24 Micro-Design, 25</p> <p>3 Micro Flash Computer Systems, Inc., 99</p> <p>— MicroRain Corp., IFC</p> <p>— Microsoft, 6-7, 11</p> <p>— Microsoft Press, 17</p> <p>117 Monogram, 56</p> <p>203 Mycroft Labs, 54</p> <p>142 NEC, 16</p> <p>197 Number Cruncher Stat-System, 174</p> <p>13 Odesta, 26-27</p> <p>34 Optimum Computer Luggage, 149</p> <p>38 Organizational Software Corp., 39</p>	<p>Reader Service Number</p> <p>74 Palantir, 132</p> <p>4 PC Connection, 80-83</p> <p>45 PC Network, 131</p> <p>124 Peachtree Software, 31</p> <p>77 ProVUE Development Corporation, 8</p> <p>127 Priority Software, Inc., 29</p> <p>172 Qubie', 23</p> <p>182 RandM Software, 174</p> <p>49 RealData, Inc., 130</p> <p>36 The Reference Corporation, 146</p> <p>39 Replico Technologies, 130</p> <p>184 Secure-It, Inc., 171</p> <p>102 Servidyne Systems, Inc., 172</p> <p>198 Simon & Schuster, Inc., 100</p> <p>94 SoftDesign, IBC</p> <p>84 SofTech Microsystems, Inc., 62</p> <p>123 Software Apple-Cations, 172</p> <p>79 Software Arts, Inc., 78</p> <p>— Software Publishing Corporation, 94</p> <p>186 SoftWeave Co., 52</p> <p>121 South Bay Software, 171</p> <p>181 State of the Art, Inc., 105</p> <p>132 Sunol Systems, 133</p> <p>135 Synergy Products, 173</p> <p>177 Systems Control, 93</p> <p>187 Tardis Software, Inc., 64</p> <p>14 Tecmar, 1, BC</p> <p>55 Telasoft, 146</p> <p>54 Telos Software Products, 89</p> <p>10 Think Educational Software, 173</p> <p>167 Thunderware, Inc., 30</p> <p>205 Touchstone Corporation, 67</p> <p>122 Triple Play, 173</p> <p>42 Videx, Inc., 33</p> <p>183 Warner Software, Inc., 104</p> <p>188 Your Affordable Software Co., 174</p>
--	--	--	---

The MacHutch

for the Macintosh™

A Distinctive piece of Furniture

A Desk Top Organizer for All Those Macintosh™ Accessories and Peripherals

This is an Elegant Piece of Furniture Made To fit on a Desk Top or Table Top

The MacHutch Comes in Four Models

Solid Oak Wood	Solid Pine Wood	Real Wood Veneer	Simulated Wood Grain
\$199.95	\$166.95	\$179.95	\$99.95

For the Executive or Home Use

For the Student

To order or for further information Contact:

Computer Alternatives, Inc. Prices do not include Tax or Shipping

2035 Hwy 64-70 SE
Hickory, N.C. 28601 (704) 324-2040

Macintosh is a registered Trademark of Apple Computer, Inc.

Circle 202 on reader service card

Reader Inquiry Service

◆◆◆◆ Would you like further information on a product that's advertised in Macworld? Well, it's easy and best of all—FREE!

Just follow these simple instructions:

- Print or type your name and address on the attached card. One card per person, please.
- Circle the number(s) on the card corresponding to the Reader Service Number in the Advertiser Index.
- Stamp, drop the card in a mailbox, and wait to receive the literature that will be mailed to you free of charge from the manufacturer.

The address on the attached card is for product information only.
Send editorial comments or inquiries to *Macworld*, 555 De Haro St., San Francisco, CA 94107

1 2 3 4 5 6 7 8 9 10 11 12 13 14 15 16
17 18 19 20 21 22 23 24 25 26 27 28 29 30 31 32
33 34 35 36 37 38 39 40 41 42 43 44 45 46 47 48
49 50 51 52 53 54 55 56 57 58 59 60 61 62 63 64
65 66 67 68 69 70 71 72 73 74 75 76 77 78 79 80
81 82 83 84 85 86 87 88 89 90 91 92 93 94 95 96
97 98 99 100 101 102 103 104 105 106 107 108 109 110 111 112
113 114 115 116 117 118 119 120 121 122 123 124 125 126 127 128
129 130 131 132 133 134 135 136 137 138 139 140 141 142 143 144
145 146 147 148 149 150 151 152 153 154 155 156 157 158 159 160
161 162 163 164 165 166 167 168 169 170 171 172 173 174 175 176
177 178 179 180 181 182 183 184 185 186 187 188 189 190 191 192
193 194 195 196 197 198 199 200 201 202 203 204 205 206 207 208
209 210 211 212 213 214 215 216 217 218 219 220 221 222 223 224
225 226 227 228 229 230 231 232 233 234 235 236 237 238 239 240
241 242 243 244 245 246 247 248 249 250 251 252 253 254 255 256
257 258 259 260 261 262 263 264 265 266 267 268 269 270 271 272

MACWORLD
The Macintosh Magazine

Name

Company

Address

City/State/Zip

(Zip code needed to insure delivery)

Please bill me \$24 for a 1-year (13-issue) subscription to *Macworld* (U.S. and Canada only).

PLEASE
PLACE
STAMP
HERE

Macworld
P.O. Box 13817
Philadelphia, PA 19101

Don't go fishing for software that won't solve your problems.

TimeBase™



"THE WAIT IS FINALLY OVER!"

The selection of Macintosh™ software is growing daily. Now it's time to manage this software. Time to put information where it belongs, when it belongs!

Introducing TimeBase™, the first "Integrated Software Centralizer" for Macintosh. This versatile time management system organizes your day-to-day business activities by interacting with your application software.

"FIVE EVERYDAY BUSINESS FUNCTIONS THAT SPELL ORGANIZATION."

TIME MANAGEMENT

The first time manager of its kind. It keeps track of multiple daily, weekly and monthly schedules years in advance. Scheduling reminders, recurring appointments and priorities is a breeze. And since TimeBase combines five other applications, it does things previous time management programs only dreamt of.

INFORMATION MANAGEMENT

The Electronic File Cabinet manages up to 100 records or files. You can locate and print any record with a click, or print the entire contents in a report.

TMP™ (TRACKING, MAINTAINING & PLANNING)

Track information flow, call backs, accounts payable/receivable and deadlines. Maintain records and schedules. Even plan long and short term projects or events.

FORMS & LETTERS

A collection of ready-made forms and letters that includes: invoice, statement, memos, collection, sales order and more.

CENTRALIZATION

Interact information from your other Macintosh programs with your daily, weekly and monthly schedules. Whether it's your word processor, database, spreadsheet or any other, it's as easy as "cut and paste." The result is better management of time and information.

"TIMEBASE CAN DO ANYTHING YOUR APPLICATION SOFTWARE CAN DO . . . ONLY BETTER!"

How? By working with them and centralizing their functions. Why not get the most out of your software. After all, what good is your computer if you spend most of your time wading through "software slush?" Imagine being able to link information from almost any program to your busy schedule. This avoids the delay in having to insert different disks to access documents, files or records.

So if you would like to know more about TimeBase, the unique time and information management system, see your local computer dealer, or contact SoftDesign directly.



14145 S.W. 142 Ave., Miami, Florida 33186
(305) 253-5521

Circle 94 on reader service card

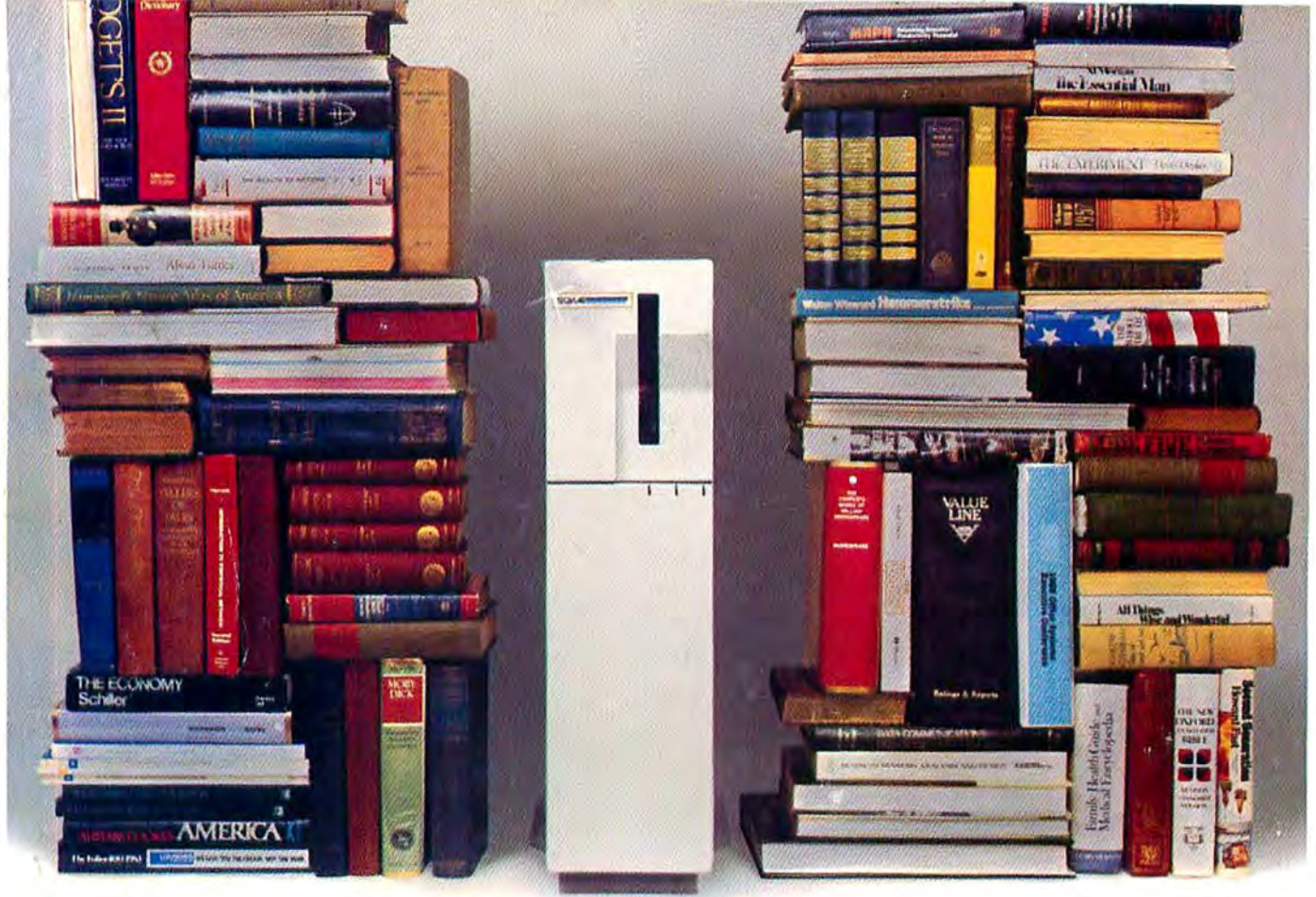

You can fill a Tecmar Massfile with all of these. Twice.

Great authors need great storage. Everyone from Aeschylus to Zola can put their thoughts to rest in Tecmar's Massfile.

Like great authors great businesses (or soon to be great) need great storage. If your business demands the full capability of your **IBM PC** or **Apple Lisa**, you should demand the features of Tecmar's Massfile.

Mainframe Storage for Micros — access up to 74 Megabytes from your personal computer.

Reliability & Performance — with a Tecmar Massfile you have the data integrity and reliability normally found only in large mini and mainframe computers. Massfile is very fast, too. You get a disk drive average access time of 35 milliseconds and a data transfer rate of up to 1.2 megabytes/second.



Fast, accurate backups — make backups and archival copies for all your important data (up to 0.5 megabytes/second) with the built-in streaming tape cartridge system. That means backing up all 74 Megabytes in less than 20 minutes.

Easy to use — use your Tecmar Massfile just like any disk on your IBM PC or Apple Lisa. You will find that Massfile is ideal for use with Unix, Xenix, networking, and/or large data bases.

All Tecmar products are backed with a commitment to quality and innovation. Protect your investment by using value-added hardware from Tecmar. For additional information contact Tecmar, Inc., 6225 Cochran Road, Cleveland, Ohio 44139; (216) 349-0600.

Circle 14 on reader service card

Tecmar
THE POWER BEHIND THE PC