



# "S" SERIES BELT CONVEYOR



## *Operator's Manual*



## **INTRODUCTION**

Thank you for choosing USC, LLC for your equipment needs. We appreciate your business and will work diligently to ensure that you are satisfied with your choice.

### **OVERVIEW**

The purpose of this manual is to provide you with the basic information needed to operate and maintain the “S” Series Conveyor. It does not hold USC, LLC liable for any accidents or injuries that may occur.

### **OPERATOR RESPONSIBILITIES**

As the purchaser/owner/operator of this equipment and control system, you have an obligation to install, operate, and maintain the equipment in a manner that minimizes the exposure of people in your care to any potential hazards inherent in using this equipment. It is critical that the owner of this equipment:

- Has a clear and documented understanding of the process this machine is being used in and of any resulting hazards or special requirements arising from this specific application.
- Allow only properly trained and instructed personnel to install, operate, or service this equipment.
- Maintain a comprehensive safety program involving all who work with this machine and other associated process equipment.
- Establish clear areas of staff responsibility (e.g. operation, setup, sanitation, maintenance, and repairs).
- Provide all personnel with necessary safety equipment.
- Periodically inspect the equipment to insure that the doors, covers, guards, and safety devices are in place and functioning, that all safety instructions and warning labels are intact and legible, and that the equipment is in good working order.
- In addition to the operating instructions, observe and enforce the applicable legal and other binding regulations, national and local codes.

As the person with the most to gain or lose from working safely, it is important that you work responsibly and stay alert. By following a few simple rules, you can prevent an accident that could injure or kill you or a co-worker.

- Disconnect, lockout, and tagout electrical and all other energy sources before inspecting, cleaning, servicing, repairing, or any other activity that would expose you to the hazards of electrical shock.

## "S" SERIES BELT CONVEYOR

- Do not operate, clean, or service this equipment until you have read and understood the contents of this manual. If you do not understand the information in this manual, bring it to the attention of your supervisor, or call your local USC dealer for assistance.
- Any operator who is known or suspected to be under the influence of alcohol or drugs should not be allowed to operate the equipment.
- Understand and follow the safety practices required by your employer and this manual.
- **PAY ATTENTION** to what you and other personnel are doing and how these activities may affect your safety.
- **Failure to follow these instructions may result in serious personal injury or death.**

### **RECEIVING YOUR EQUIPMENT**

As soon as the equipment is received, it should be carefully inspected to make certain that it has sustained no damage during shipment and that all items listed on the packing list are accounted for. If there is any damage or shortages, the purchaser must immediately notify your USC dealer. Ownership passes to purchaser when the unit leaves the USC, LLC premises. The purchaser is responsible for unloading and mounting all components of the equipment.

Document the serial number of the machine for future reference. The serial number is located on the side of the conveyor near the hitch.



*Serial  
Number*

**SERIAL NUMBER:** \_\_\_\_\_

# **TABLE OF CONTENTS**

<b><u>Section</u></b>	<b><u>Contents</u></b>	<b><u>Page #</u></b>
<b>Section A</b>	<b>Safety Instructions .....</b>	<b>5</b>
<b>Section B</b>	<b>Installation .....</b>	<b>16</b>
<b>Section C</b>	<b>Mechanical Operation .....</b>	<b>22</b>
	Controls.....	23
	Pre-Operation Checklist .....	24
	Operating .....	25
	Machine Break-in .....	27
<b>Section D</b>	<b>Transporting .....</b>	<b>28</b>
<b>Section E</b>	<b>Troubleshooting .....</b>	<b>30</b>
<b>Section F</b>	<b>Maintenance .....</b>	<b>32</b>
<b>Section G</b>	<b>Storage.....</b>	<b>37</b>
<b>Section H</b>	<b>Mechanical Drawings.....</b>	<b>38</b>
<b>Section I</b>	<b>Limited Warranty .....</b>	<b>81</b>

# SAFETY INSTRUCTIONS

## SECTION A

Every year accidents in the work place maim, kill, and injure people. Although it may be impossible to prevent all accidents, with the right combination of training, operating practices, safety devices, and operator vigilance, the number of accidents can be significantly reduced. The purpose of this section is to educate equipment users about hazards, unsafe practices, and recommended hazard avoidance techniques.

### SAFETY WORDS AND SYMBOLS

It is very important that operators and maintenance personnel understand the words and symbols that are used to communicate safety information. Safety words, their meaning and format, have been standardized for U.S. manufacturers and published by the American National Standards Institute (ANSI). The European Community (E.C.) has adopted a different format based on the International Standards Organization (I.S.O.) and applicable machinery directives. Both formats are presented below. Graphic symbols are not standardized, but most manufacturers will use some variation of the ones seen in this manual.



Indicates an imminently hazardous situation which, if not avoided, **will** result in death or serious injury.



Indicates a potentially hazardous situation which, if not avoided, **could** result in death or serious injury.



Indicates a potentially hazardous situation which, if not avoided, **may** result in minor or moderate injury and/or property damage.



Provides additional information that the operator needs to be aware of to avoid a potentially hazardous situation.



**Mandatory Lockout Power Symbol.** Disconnect, lockout, and tagout electrical and other energy sources before inspecting, cleaning, or performing maintenance on this panel.



**International Safety Alert Symbol.** The exclamation point (!) surrounded by a yellow triangle indicates that an injury hazard exists. However, it does not indicate the seriousness of potential injury. The exclamation point (!) is also used with the DANGER, WARNING, and CAUTION symbols so the potential injury is indicated.



**Electrocution Hazard Symbol.** This symbol indicates that an electrocution hazard exists. Serious injury or death could result from contacting high voltage.



**International Electrocution Hazard.** This symbol indicates that an electrocution hazard exists. Serious injury or death could result from contacting high voltage.



**Mandatory Read Manual Action Symbol.** (I.S.O. format)  
This symbol instructs personnel to read the Operators Manual before servicing or operating the equipment.



**Mandatory Read Manual Action Symbol.** This symbol instructs personnel to read the Operators Manual before servicing or operating the equipment.

**NOTICE**

Notice is used to notify people of important installation, operation, or maintenance information which is not hazard related.

## **LOCKOUT / TAGOUT PROCEDURES**

Lockout/Tagout is the placement of a lock/tag on an energy isolating device in accordance with an established procedure. When taking equipment out of service to perform maintenance or repair work, always follow the lockout/tagout procedures as outlined in ANSI Z344.1 and/or OSHA Standard 1910.147. This standard “requires employers to establish a program and utilize procedures for affixing appropriate lockout devices or tagout devices to energy isolating devices and to otherwise disable machines or equipment to prevent unexpected energizing, start-up, or release of stored energy in order to prevent injury to employees.”

### **CONTROLLED STOP**

This is the stopping of machine motion by reducing the electrical command signal to 0 (zero) once the stop signal has been recognized.

### **HAZARD REVIEW**



#### **Electrocution Hazard**

Electrocution accidents are most likely to occur during maintenance of the electrical system or when working on or near exposed high voltage wiring.



This hazard does not exist when the electrical power has been disconnected, properly locked, and tagged out.



#### **Automatic Start Hazard**

This seed treating system is usually controlled by an automated system and may start without warning. Failure to properly disconnect, lockout, and tagout all energy sources of remotely controlled equipment creates a very hazardous situation and could cause injury or even death. PLEASE STAY CLEAR AND BE ALERT.



**YOU** are responsible for the **SAFE** operation and maintenance of your USC, LLC Seed Treating System. **YOU** must ensure that you and anyone else who is going to operate, maintain, or work around the Seed Treating System be familiar with the operating and maintenance procedures and related **SAFETY** information contained in this manual. This manual will take you step-by-step through your working day and alert you to good safety practices that should be adhered to while operating the Conveyor.

Remember, **YOU** are the key to safety. Good safety practices not only protect you, but also the people around you. Make these practices a working part of your safety program. Be certain that **EVERYONE** operating this equipment is familiar with the recommended operating and maintenance procedures and follows all the safety precautions. Most accidents can be prevented. Do not risk injury or death by ignoring good safety practices.

- “S” Series Conveyor owners must give operating instructions to operators or employees before allowing them to operate the machine, and at least annually thereafter per OSHA (Occupational Safety and Health Administration) regulation 1928.57.
- The most important safety device on this equipment is a **SAFE** operator. It is the operator’s responsibility to read and understand **ALL** Safety and Operating instructions in the manual and to follow them. All accidents can be avoided.
- A person who has not read and understood all operating and safety instructions is not qualified to operate the machine. An untrained operator exposes himself and bystanders to possible serious injury or death.
- Do not modify the equipment in any way. Unauthorized modification may impair the function and/or safety and could affect the life of the equipment.
- Think SAFETY! Work SAFELY!

### **GENERAL SAFETY**

1. Read and understand the Operator’s Manual and all safety signs before operating, maintaining, adjusting or unplugging the Conveyor.
2. Only trained persons shall operate the seed treater. An untrained operator is not qualified to operate the machine.
3. Have a first-aid kit available for use should the need arise, and know how to use it.





“S” SERIES BELT CONVEYOR

4. Provide a fire extinguisher for use in case of an accident. Store in a highly visible place.
5. Do not allow children, spectators or bystanders within hazard area of machine.
6. Wear appropriate protective gear. This includes but is not limited to:

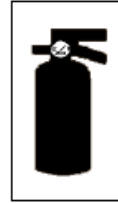

- A hard hat
- Protective shoes with slip resistant soles
- Protective goggles
- Heavy gloves
- Hearing protection
- Respirator or filter mask



7. Place all controls in neutral or off, stop motor, and wait for all moving parts to stop. Then disable power source before servicing, adjusting, repairing, or unplugging.
8. Review safety related items annually with all personnel who will be operating or maintaining the Conveyor.



**OPERATING SAFETY:**

1. Read and understand the Operator’s Manual and all safety signs before using.
2. Disconnect and disable electrical supply completely and wait for all moving parts to stop before servicing, adjusting, repairing or unplugging.
3. Clear the area of bystanders, especially children, before starting.
4. Be familiar with the machine hazard area. If anyone enters hazard area, shut down machine immediately. Clear the area before restarting.
5. Keep hands, feet, hair and clothing away from all moving and/or rotating parts.
6. Stay away from overhead obstructions and power lines during operation and transporting. Electrocution can occur without direct contact.
7. Do not operate machine when any guards are removed.
8. Inspect welds and repair if needed.

## **TRANSPORT SAFETY**

1. Read and understand ALL the information in the Operator's Manuals regarding procedures and SAFETY when moving or transporting the Conveyor.
2. Check with local authorities regarding Conveyor transport on public roads. Obey all applicable laws and regulations.
3. Always travel at a safe speed. Use caution when making corners or meeting traffic.
4. Make sure the SMV (Slow Moving Vehicle) emblem and all the lights and reflectors that are required by the local highway and transport authorities are in place, are clean and can be seen clearly by all overtaking and oncoming traffic.
5. Do not allow riders on the Conveyor or the towing vehicle when transporting.
6. Attach Conveyor to towing vehicle with a pin and retainer.
7. Lower Conveyor to its lowest position for transporting. Keep lift point at drawbar height.
8. Keep to the right and yield the right-of-way to allow faster traffic to pass. Drive on the road shoulder, if permitted by law.
9. Do not exceed 25 m.p.h. (40 km/h). Reduce speed on rough roads and surfaces.
10. Stay away from overhead obstructions and power lines when transporting. Electrocutation can occur without direct contact.
11. Always use hazard warning flashers on tractor when transporting unless prohibited by law.

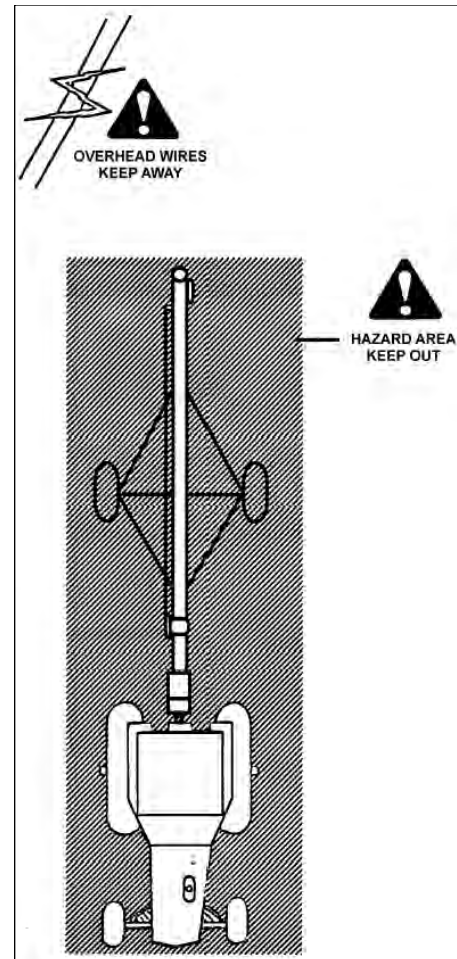

### **TIRE SAFETY**

1. Failure to follow proper procedures when mounting a tire on a wheel or rim can produce an explosion which may result in serious injury or death.
2. Do not attempt to mount a tire unless you have the proper equipment and experience to do the job.
3. Have a qualified tire dealer or repair service perform required tire maintenance.
4. When replacing worn tires, make sure they meet the original tire specifications. Never undersize.



Before placement of the Conveyor, be sure that ground is reasonably level. The Conveyor may topple or work improperly if the ground is too uneven, damaging the equipment and/or causing personal injury.



When releasing the Conveyor from the towing vehicle, test the intake end for downward weight. Do not raise the intake end above drawbar height. When the intake end is elevated too high with machine in raise position, the balance of weight quickly transfers to the discharge end,

### **MAINTENANCE SAFETY**

1. Review the Operator's Manual and all safety items before working with, maintaining or operating the Conveyor.
2. Place all controls in neutral or off, stop motors, disable power source, and wait for all moving parts to stop before servicing, adjusting, repairing or unplugging.
3. Follow good shop practices:

Keep service area clean and dry.  
Be sure electrical outlets and tools are properly grounded.  
Use adequate light for the job at hand.

4. Keep hands, feet, hair and clothing away from all moving and/or rotating parts.
5. Clear the area of bystanders, especially children, when carrying out any maintenance and repairs or making any adjustments.
6. Before resuming work, install and secure all guards when maintenance work is completed.
7. Keep safety signs clean. Replace any sign that is damaged or not clearly visible.



## **PLACEMENT SAFETY**

1. Move only with the appropriate equipment
2. Stay away from overhead power lines when moving the Conveyor. Electrocutation can occur without direct contact.
3. Be familiar with machine hazard area. If anyone enters hazard areas, shut down machine immediately. Clear the area before restarting.
4. Operate the Conveyor on level ground free of debris. Anchor the Conveyor to prevent tipping or upending.

## **SAFETY SIGNS**

1. Keep safety signs clean and legible at all times.
2. Replace safety signs that are missing or have become illegible.
3. Replaced parts that displayed a safety sign should also display the current sign.
4. Safety signs are available from your Authorized Dealer.

### **How to Install Safety Signs:**

- Be sure that the installation area is clean and dry.
- Be sure temperature is above 50°F (10°C).
- Decide on the exact position before you remove the backing paper.
- Remove the smallest portion of the split backing paper.
- Align the sign over the specified area and carefully press the small portion with the exposed sticky backing in place.
- Slowly peel back the remaining paper and carefully smooth the remaining portion of the sign in place.
- Small air pockets can be pierced with a pin and smoothed out using the piece of sign backing paper.



Located on the USC equipment you will find safety labels. Always be sure to read and follow all directions on the labels.



“S” SERIES BELT CONVEYOR

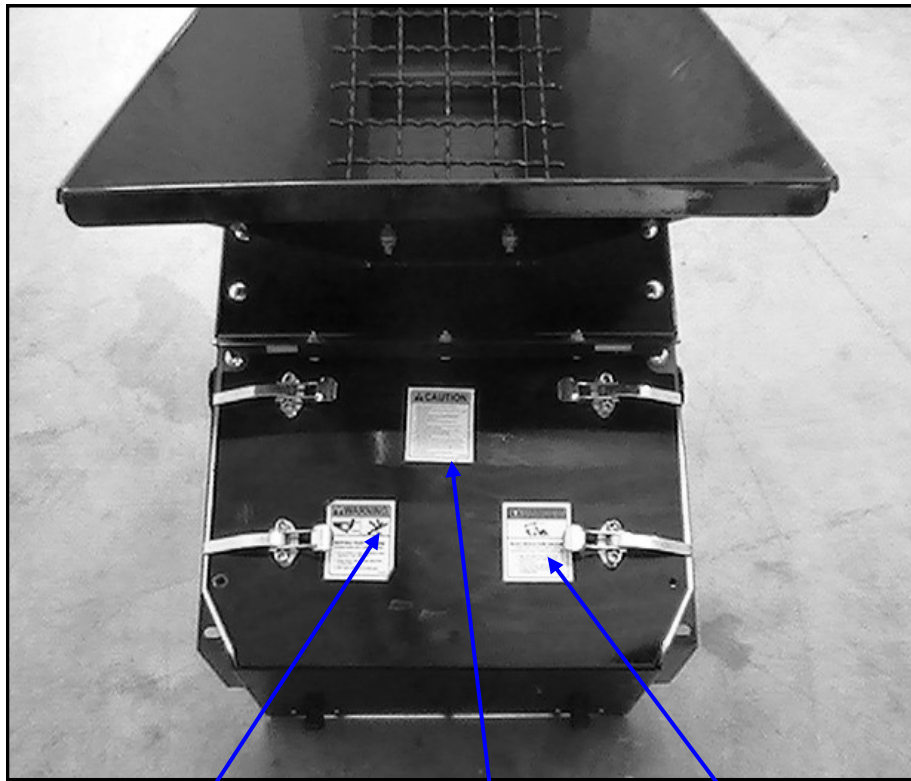

**▲ WARNING**

**MOVING PART HAZARD**  
To prevent serious injury or death from falling:

1. Do not stand or climb on machine when operating. Keep others off.
2. Keep hands feet and hair away from moving parts.
3. Wear tight clothing and safety gear.

820-0-0511

**▲ CAUTION**

1. Read and understand the Operator's Manual before operating.
2. Keep all safety shields and devices in place and in good working order.
3. Make certain everyone is clear before operating or moving the machine. Keep children, visitors and untrained people away.
4. Keep hands, feet, hair and clothing away from moving parts.
5. Shut off and disable power source before adjusting, servicing, repair or cleaning.
6. Disconnect power before resetting motor overload.
7. Be sure electric motors are grounded.
8. Support discharge and/or anchor intake end to prevent upending.
9. Empty Conveyor before moving to prevent upending.
10. Lower Conveyor to its fully down position before moving or transporting. Use a tractor to move and transport.
11. Lower Conveyor well below level of power lines before moving or transporting. Electrocutation can occur without direct contact.
12. Keep away from Intakes. Keep others away.
13. Train operators annually.

820-0-0038

**▲ DANGER**

**ELECTROCUTION HAZARD**  
**KEEP AWAY FROM POWER LINES**  
To prevent serious injury or death from electrocution:

1. Stay well away from power lines. Electrocutation can occur without direct contact.
2. Lower Conveyor well below level of power line before moving or transporting.

820-0-0537

“S” SERIES BELT CONVEYOR

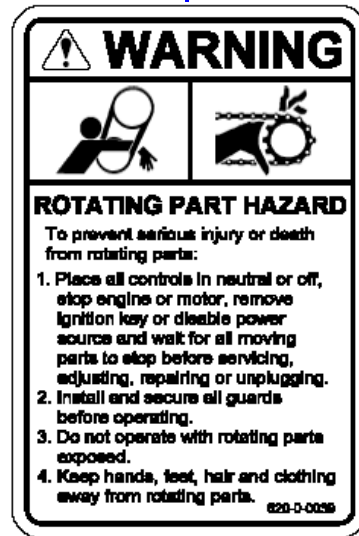
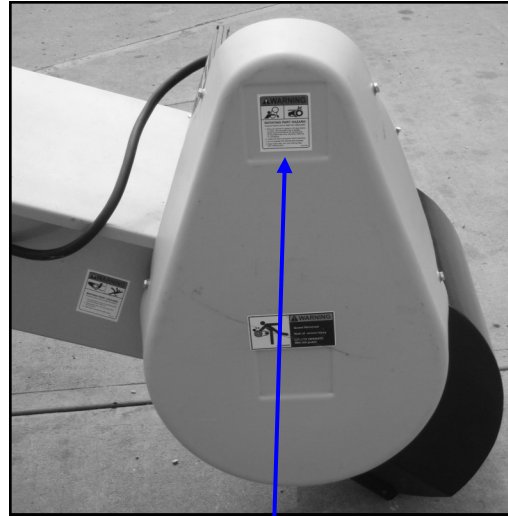

- Think SAFETY! Work SAFELY!

REMEMBER—If Safety Signs have been damaged, removed, become illegible, or parts replaced without safety signs, new signs must be applied. New safety signs are available from your Authorized Dealer.

“S” SERIES BELT CONVEYOR

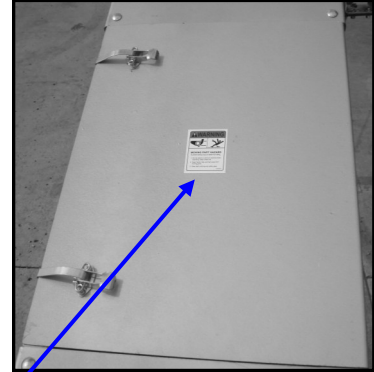
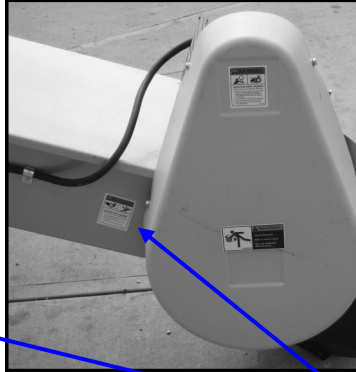
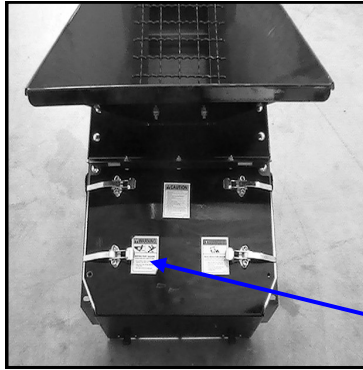

**REMEMBER**—If Safety Signs have been damaged, removed, become illegible, or parts replaced without safety signs, new signs must be applied. New safety signs are available from your Authorized Dealer.

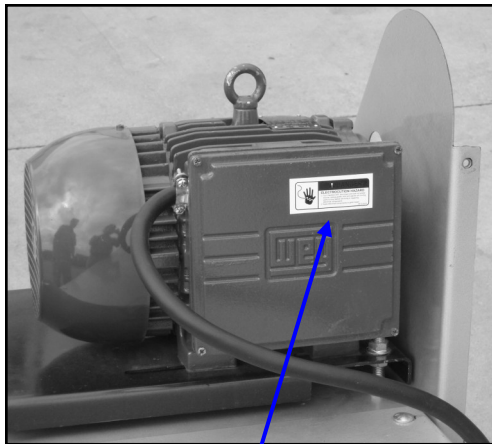

*Safety decal location (location may vary depending on motor model)*

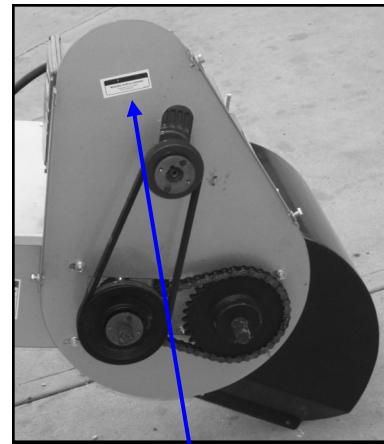

**SECTION  
B**

**INSTALLATION**



**HIGH VOLTAGE** ~ Always disconnect the power source before working on or near the control panel or lead wires.



**HIGH VOLTAGE** ~ Use insulated tools when making adjustments while the controls are under power.

**NOTICE**

Permanent installation may require additional electrical cords since each installation is unique.

**ASSEMBLING CONVEYOR**

1. Using a forklift, pick up the conveyor in the center.
2. Remove the angle supports from the slide stops and install them on the bottom of the slide stops. Make sure to place the slide in between the two stops before connecting the angle supports.

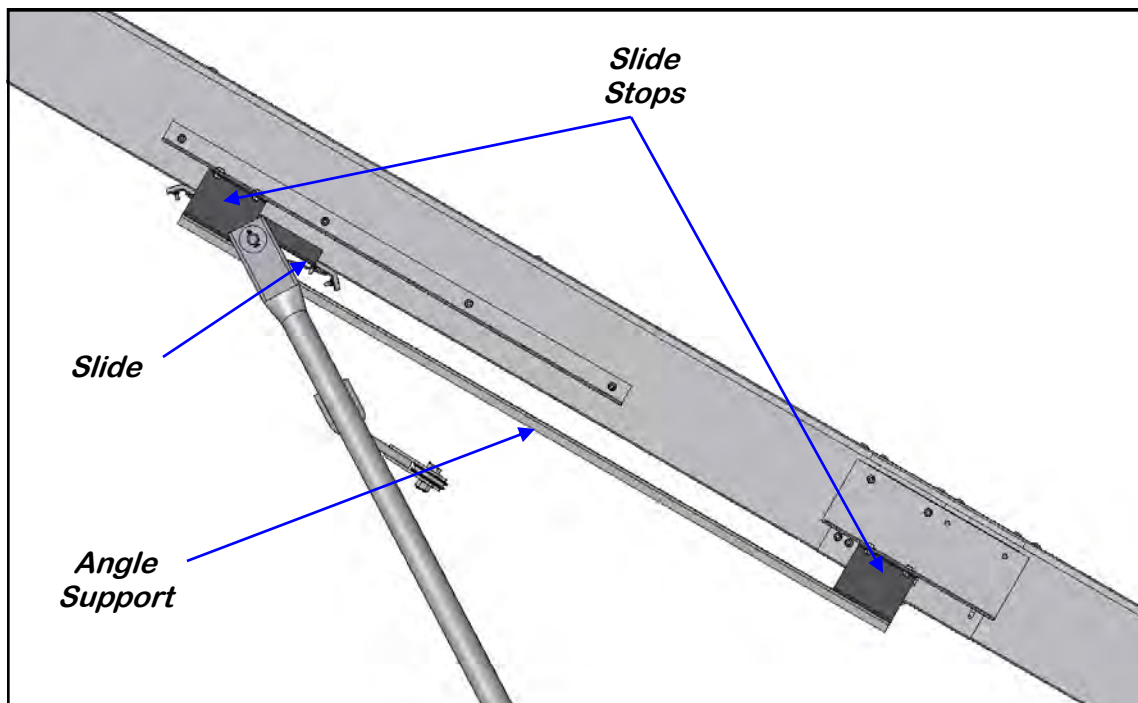



### INSTALLING UNDER-CARRIAGE

1. Lay the under-carriage flat on the ground.
2. Using a forklift, pick up the conveyor in the center **(A)** and bring over the top of the under-carriage.
3. Connect the bottom under-carriage to the bottom part of the conveyor using the pin provided **(B)**.
4. Lift up the conveyor until the under-carriage can be connected to the slide on the conveyor **(C)**.
5. Lower the conveyor down so the bottom end of the conveyor is sitting on the ground.
6. Install the winch to the bracket on the under-carriage **(D)**.

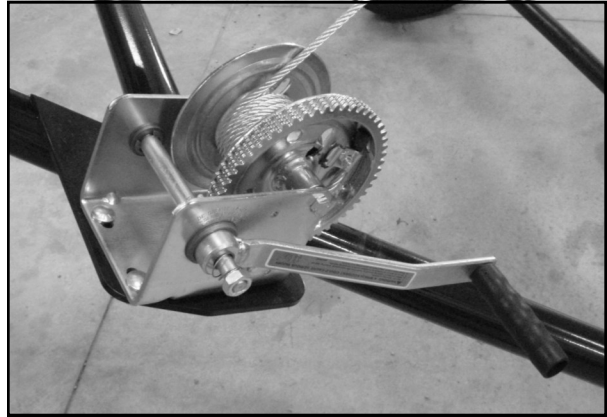

*Picture of Slide Assembly after Installation*

"S" SERIES BELT CONVEYOR

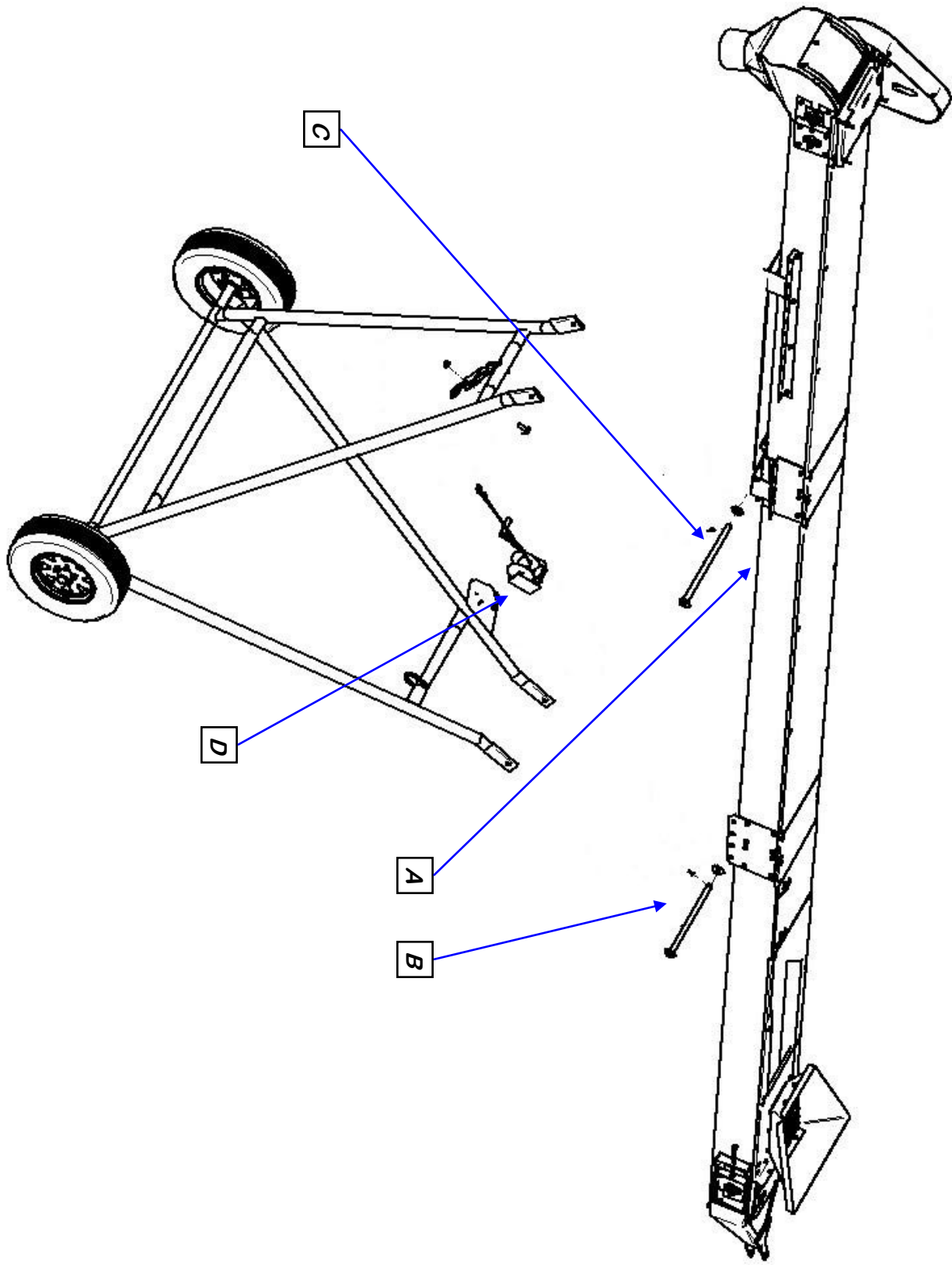

**INSTALLING UNDER-CARRIAGE**

7. Attach the cable to the crank.
8. String the cable through the pulley and attach to the lower portion of the under-carriage (see pictures below).

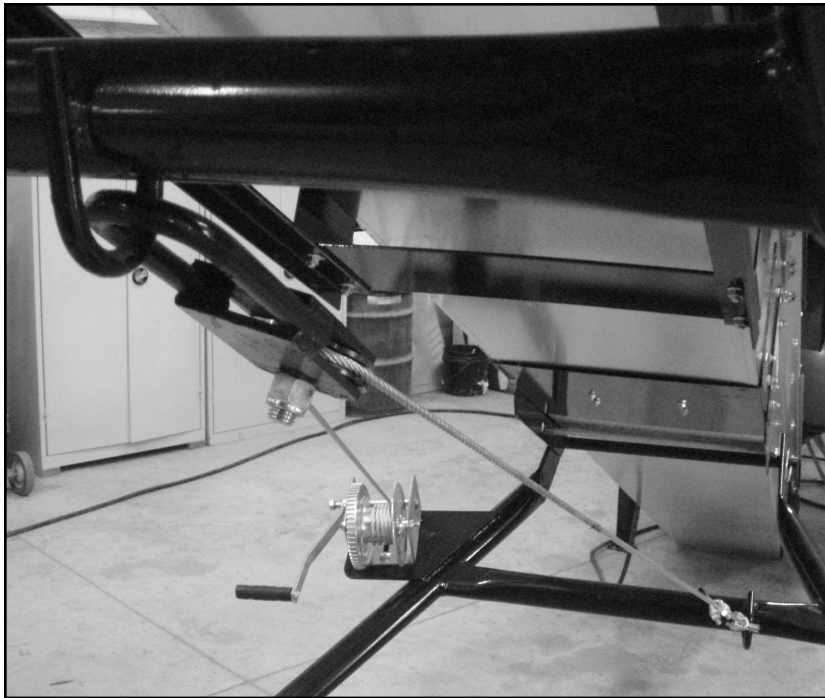

## **SET-UP**

The following steps outline the initial set-up of your USC “S” Series Conveyor:

1. Clear the area of bystanders, especially small children, before starting.
2. Be sure there is enough clearance from overhead obstructions and power lines or other equipment to move the machine into its working position.
3. Attach the Conveyor to an appropriate towing vehicle.
4. Move conveyor as near as possible to desired position.
5. Set the park brake on the towing vehicle before dismounting.
6. Unhook the unit from the towing vehicle.
7. Use the winch to raise the machine so it clears the truck, trailer or wagon.
8. Place chocks in the front and rear of each wheel.
9. It will be necessary to stake or weight the intake end to prevent upending when the machine is emptying.
10. Review the Workplace Safety Diagram for your model prior to starting work. Follow all setup instructions and do not allow any unauthorized people into the working area.
11. Have a certified electrician provide power to the conveyor. Provide convenient shutdown switches and comply with local electrical codes. The conveyor can also be plugged directly into a USC seed treater control panel.



Ensure that the seed treater panel and the conveyor are rated for the same power before plugging the conveyor into the seed treater panel.

12. Reverse the above procedure when removing the machine from its working position.

“S” SERIES BELT CONVEYOR

**NOTES**

A large, empty rectangular box with a black border, intended for handwritten notes.

SECTION  
C

# MECHANICAL OPERATION



## OPERATING SAFETY

1. Read and understand the Operator's Manual and all safety signs before using.
2. Electric motor drives: Disconnect and disable electrical supply completely and wait for all moving parts to stop before servicing, adjusting, repairing or unplugging.
3. Clear the area of bystanders, especially children, before starting.
4. Be familiar with machine hazard area. If anyone enters hazard areas, shut down machine immediately. Clear the area before restarting.
5. Keep hands, feet, hair and clothing away from all moving and/or rotating parts.
6. Do not allow riders on the Conveyor or transport vehicle when transporting.
7. Stay away from overhead obstructions and power lines during operation and transporting. Electro-cution can occur without direct contact.
8. Do not operate machine when any guards are removed.
9. Lower Conveyor to its lowest position before moving or transporting or when not in use.
10. Inspect lift cable before using Conveyor. Replace if frayed or damaged.
11. Make certain lift cable is properly seated in cable pulleys.
12. Be sure that conveyor is empty before raising or lowering.

The USC, LLC “S” Series Belt Conveyor is designed to efficiently move seed between a storage facility or seed totes and a truck, trailer or seed treater. Power is provided by an electric motor. Be familiar with the machine before starting.

It is the responsibility of the owner or operator to read this manual and to train all other operators before they start working with the machine. In addition to the design and configuration of equipment, hazard control and accident prevention are dependent upon the awareness, concern, and prudence of personnel involved in the operation, transport, maintenance and storage of equipment or in the use and maintenance of facilities.

### NOTICE

Follow all safety instructions exactly. Safety is everyone's business. By following recommended procedures, a safe working environment is provided for the operator, bystanders and the area around the worksite. Untrained operators are not qualified to operate the machine.

Many features incorporated into this machine are the result of suggestions made by customers like you. Read this manual carefully to learn how to operate the machine safely and how to set it to provide maximum efficiency. By following the operating instructions in conjunction with a good maintenance program, your conveyor will provide many years of trouble-free service.

## "S" SERIES BELT CONVEYOR

### SYSTEM OVERVIEW

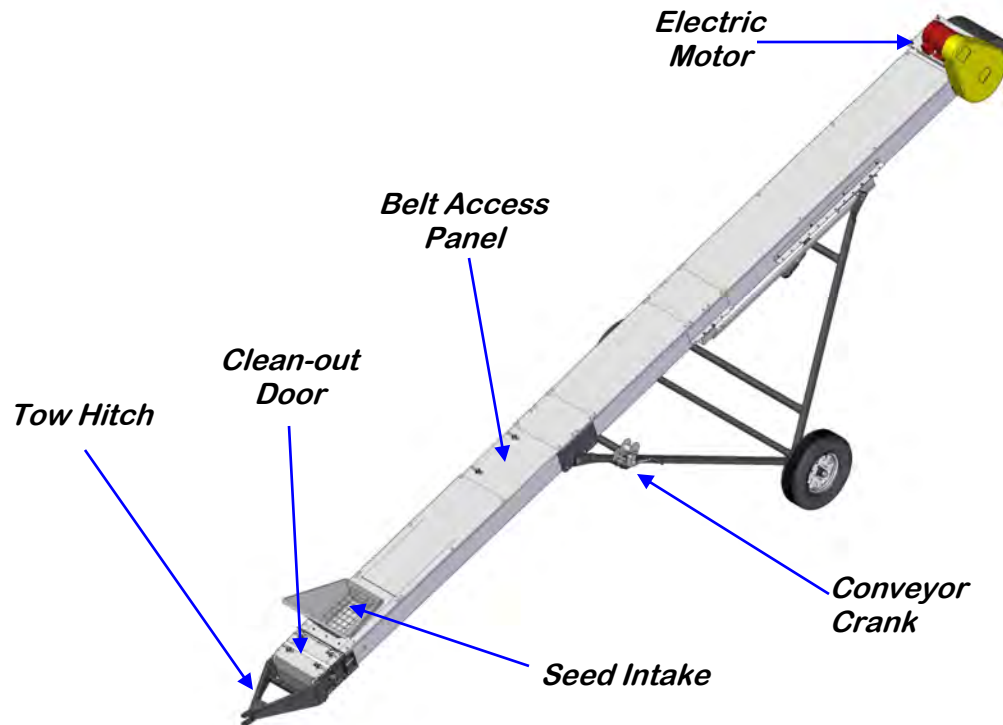

### CONTROLS

- **Electric Drive:** Have a licensed electrician provide power to the machine per the National Electrical Code ANSI/NFPA 70 and local codes. Install an ON, OFF switch for the convenience of the operator.
- **Manual Winch:** A winch is located on the transport frame and is used to raise and lower the conveyor. Turn the handle clockwise to raise and counterclockwise to lower.



Maintain at least 3 wraps of cable on the drum at the maximum reach. The drum cable clamp is not designed to hold load.

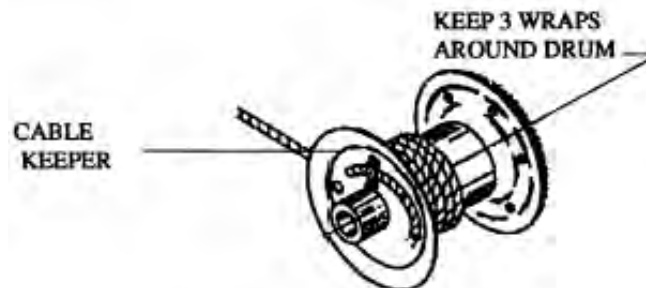

## **PRE-OPERATION CHECKLIST**

Efficient and safe operation of the USC, LLC “S” Series Belt Conveyor requires that each operator reads and understands the operating procedures and all related safety precautions outlined in this section. A pre-operation checklist is provided for the operator. It is important for both the personal safety and maintaining the good mechanical condition of the Conveyor that this checklist is followed.

Before operating the Conveyor and each time thereafter, the following areas should be checked off:

1. Service the machine per the schedule outlined in Section F, Maintenance. (Page 32)
2. Use only an electric motor of adequate power to operate the machine.
3. Check that all guards are installed, secured and functioning as intended. Do not operate with missing or damaged shields.
4. Check worksite. Clean up working area to prevent slipping or tripping.
5. Check winch and cable for security and operation. There should be at least 3 complete wraps of cable around winch drum in full down position. Cable anchor on winch drum must be tight. Inspect cable for fraying or damage and replace if damaged or frayed.
6. Check that cable clamps are secure.
7. Check that drive belt and conveying belt are not frayed or damaged and that they are properly adjusted and aligned.
8. Be sure Conveyor wheels are chocked.
9. Check that discharge and intake areas are free of obstructions.



Anchoring and/or support of Conveyor during operation is necessary. When the lower half of Conveyor empties of material, the weight balance transfers to the upper end of the machine, which can cause upending.



## **OPERATING**

When using the Conveyor, follow this procedure:

1. Clear the area of bystanders, especially small children, before starting.
2. Review the Pre-Operation Checklist (page 24) before starting.
3. Review the Workplace Hazards schematic and use extra care when inside the hazard area. Keep all bystanders out of this area. Should anyone enter this area, stop the machine immediately.
4. Set the conveyor in position. To achieve rated capacity, the conveyor should be run **no steeper than 30°**. Molded flights on the belt minimize material rollback during operation.
5. Drive or back the truck or wagon into position for loading.
6. Turn the electric motor ON and begin the flow of material and unload.
7. To stop the conveyor; stop the flow of material and run until the belt is empty. Turn off motor and lock out power source.

## **Operating hints**

- Direct the flow of material into the input hopper when moving material. Do not “flood feed” the inlet hopper.
- Always listen for any unusual sounds or noises. If any are heard, stop the machine and determine the source. Correct the problem before resuming work.
- Never allow anyone into the workplace hazard area. If anyone enters, stop immediately. Make them LEAVE before resuming work.
- Do not run the machine for long periods of time with no material on the belt. It increases the wear. Try to run the conveyor only when moving material.
- Do not support the discharge end directly on the truck box, trailer or wagon. Stake the intake (hopper) or weight it down to prevent upending.
- Use a Car Unloader or similar conveyor to move grain from under the bin discharge into the “S” series conveyor hopper when emptying low clearance facilities.

### Emergency Stopping

Although it is recommended that the machine be emptied before stopping, in an emergency situation, stop or shutdown the power source immediately. Correct the emergency before resuming work.

### Restarting

When the machine is shut down inadvertently or for an emergency, the belt may still be covered with material. It may be necessary to tighten the drive belt slightly to handle the heavier-than-normal starting loads.

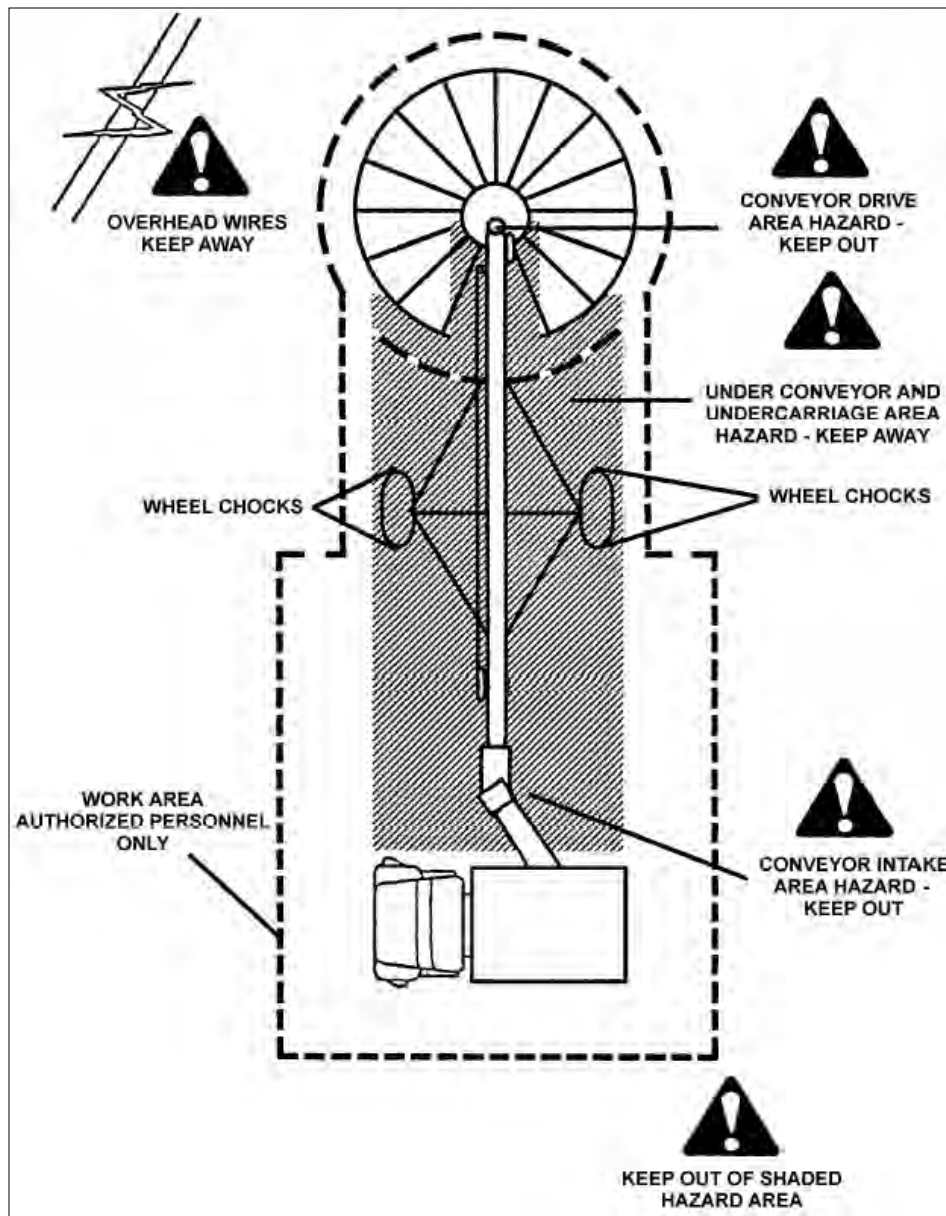

## **MACHINE BREAK-IN**

Although there are no operational restrictions on the Conveyor when used for the first time, it is recommended that the following mechanical items be checked:

### **Before starting**

1. Read the Conveyor Operator’s Manual.
2. During the conveyors first few minutes of operation, check conveyor belt alignment to ensure belt is tracking correctly when running empty and also during loaded conditions.

### **After operating or transport for 1/2 hour**

1. Re-torque all the wheel bolts.
2. Re-torque fasteners and hardware.
3. Check that all safety decals are installed and legible. Apply new decals if required.
4. Check the drive belt tension and alignment. Tension or align as required.
5. Check the conveying belt tension and alignment. Tension or align as required.
6. Check that all guards are installed and working as intended.

### **After operating for 5 hours and 10 hours**

1. Re-torque all wheel bolts, fasteners and hardware.
2. Check that all guards are installed, secured and functioning as intended. Do not operate with missing or damaged shields.
3. Check safety decals. Install new ones if required.
4. Check the drive belt, and conveying belt tension and alignment. Tension or align as required.
5. Then go to the normal servicing and maintenance schedule as defined in the Maintenance Section.

**SECTION  
D**

**TRANSPORTING**

**ATTACHING / UNHOOKING**

It is recommended that the Conveyor be attached to an appropriate towing vehicle whenever it is moved. Follow this procedure when attaching to or unhooking from a towing vehicle:

1. Position hitch plate under conveyor and align holes.
2. Install pins through hitch plate and conveyor. Then, install the washers and cotter pins to each pin.
3. Make sure that bystanders, especially small children, are clear of the working area.
4. Be sure the conveyor wheels are chocked.
5. Be sure that there is sufficient room and clearance to back up to the machine.
6. Align the drawbar of the towing vehicle with the hitch of the Conveyor while backing up.
7. Set the park brake before dismounting.
8. Align the hitch to the drawbar and install a hitch pin with a retainer (not supplied).
9. Remove chocks from machine wheels.
10. Move to new location.
11. Reverse the above procedure when unhooking.
12. Removal of the most forward pin will allow the conveyor to pivot on to the hitch plate so the hitch plate can be used as a base.

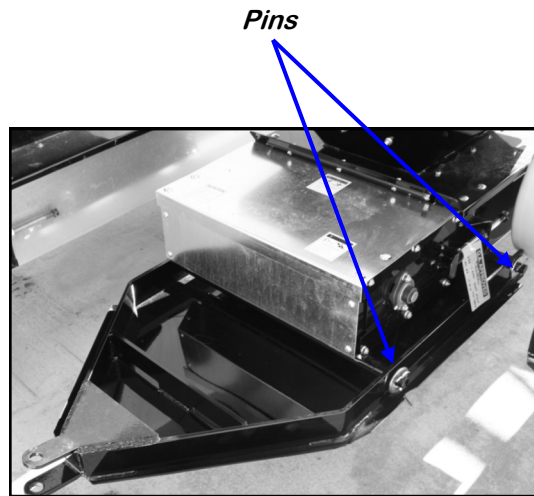

*Conveyor Hitch*

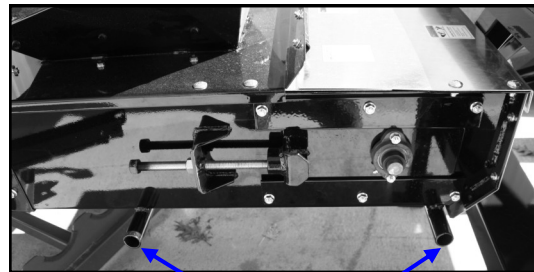

*Pins Holes*

## **TRANSPORTING**

USC, LLC “S” Series Conveyors are designed to be easily and conveniently moved from place to place. When transporting, follow this procedure:

1. Review the Transport Safety Schematic before starting.
2. Be sure all bystanders are clear of the machine.
3. On electric motor drive units, unplug the power cord, wrap around frame, and secure to prevent dragging.
4. Attach to a towing vehicle using a hitch pin with a retainer.
5. Remove chocks from the wheels.
6. Lower the conveyor into its fully down position so that the cross tube rests on the stop plate.
7. Electrocution can occur without direct contact.
8. Never go across slopes of more than 20°. It is better to go straight up or straight down a slope.
9. Make sure the SMV (Slow Moving Vehicle) emblem and all the lights and reflectors that are required by the local highway and transport authorities are in place, are clean, and can be seen clearly by all overtaking and oncoming traffic.
10. Keep to the right and yield the right-of-way to allow faster traffic to pass. Drive on the road shoulder, if permitted by law.
11. It is not recommended that the machine be transported faster than 25 mph (40 km/h).
12. Do not allow riders on the machine or towing vehicle.
13. During periods of limited visibility, use pilot vehicles or add extra lights to the machine.
14. Always use hazard flashers on the vehicle when transporting unless prohibited by law.

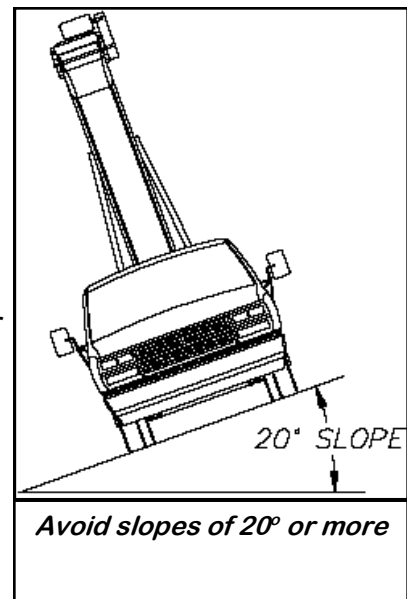
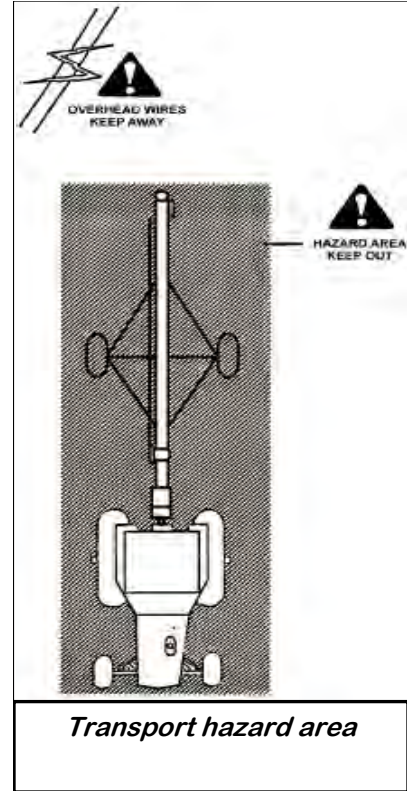

**SECTION  
E**

**TROUBLESHOOTING**

Below is a table describing the most frequent problems and solutions with the USC "S" Series Conveyor. For further assistance, contact your local USC dealer.

Problem	Possible Cause	Solution
Conveyor will not run.	<ol style="list-style-type: none"> <li>1. Not turned on.</li> <li>2. Conveying belt loose.</li> <li>3. Drive belt loose.</li> </ol>	<ol style="list-style-type: none"> <li>1. Start power source or turn on power.</li> <li>2. Tighten and align belt.</li> <li>3. Tighten drive belt.</li> </ol>
Belt edge fraying.	<ol style="list-style-type: none"> <li>1. Belt not aligned.</li> </ol>	<ol style="list-style-type: none"> <li>1. Align and tension belt.</li> </ol>
Low conveying capacity.	<ol style="list-style-type: none"> <li>1. Angle too steep.</li> <li>2. Slow operating speed.</li> <li>3. Conveyor belt slipping.</li> <li>4. Drive belt slipping.</li> </ol>	<ol style="list-style-type: none"> <li>1. Reposition with angle at 30°.</li> <li>2. Increase operating speed.</li> <li>3. Tighten belt.</li> <li>4. Set drive belt tension.</li> </ol>

**Unplugging**

In unusual moisture or material conditions, the machine can plug. When unplugging, follow this procedure:

1. Place all controls in neutral or off, stop motor, disable and lock out power source before unplugging.
2. Unbolt and remove the necessary conveyor covers.
3. Open the tail cover.
4. Remove plugged material.
5. Install and secure conveyor and tail covers.

"S" SERIES BELT CONVEYOR

**NOTES**

A large, empty rectangular box with a black border, intended for handwritten notes.

**SECTION  
F**

**MAINTENANCE**

Proper maintenance of the USC “S” Series Conveyor is critical for peak performance, reliability and accuracy of this system. The following is a guideline for the type of maintenance and servicing that should be performed on this unit. Your environment and uses may require additional maintenance and service beyond this list to assure a reliable and safe unit. The operator of this unit has ultimate responsibility to identify areas of concern and rectify them before they become a hazard or safety issue. There is no substitute for a trained, alert operator.



Do not put this unit into operation with any questionably maintained parts. Poor performance or a hazard may occur.

**FLUIDS AND LUBRICANTS**

**Grease**

Use an SAE multipurpose high temperature grease with extreme pressure (EP) performance. Also acceptable is an SAE multipurpose lithium-based grease.

**Storing Lubricants**

Your machine can operate at top efficiency only if clean lubricants are used. Use clean containers to handle all lubricants. Store them in an area protected from dust, moisture and other contaminants.

---

**GREASING**

Use a Maintenance Checklist to keep record of all scheduled maintenance.

1. Use a hand-held grease gun for all greasing.
2. Wipe grease fitting with a clean cloth before greasing to avoid injecting dirt and grit.
3. Replace and repair broken fittings immediately.

**NOTICE**

If fittings will not take grease, remove and clean thoroughly. Also clean lubricant passageway. Replace fitting if necessary.



“S” SERIES BELT CONVEYOR

**SERVICING INTERVALS**

**Every 40 hours or Weekly**

1. Check the conveyor belt tension and alignment.
2. Grease conveyor bearings.
  - Two bolt flanged bearings, tail roller bearings right and left (2 locations).
  - Two bolt flanged bearings, drive roller bearings right and left (2 locations).
  - Two bolt flanged bearings, jackshaft bearings right and left (2 locations).
3. Check the drive belt tension and alignment. The belts will deflect approximately 1/4 to 1/2 inch when properly tensioned. (right)
4. Remove yellow guard and check chain tension

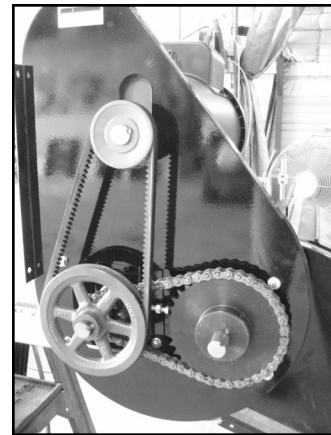
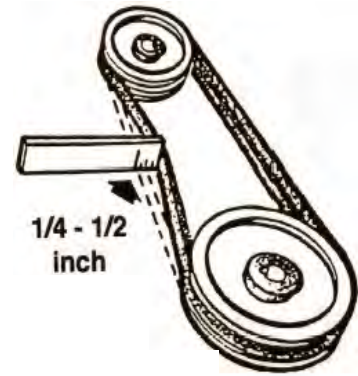

---

**Every 200 hours or Annually**

1. Repack wheel bearings.
2. Wash machine.
3. Check pulley bushing for wear. To inspect pulley:
  - A. Lower the conveyor to its lowest position.
  - B. When the conveyor has reached the lowest position, it will stop at the pins.
  - C. Unwind the winch two more turns, or until enough slack in the cable is achieved.
  - D. Loosen and remove the bolt.
  - E. Inspect the bushing on the pulley for wear.
  - F. Reverse steps A-D for re-assembly.

## **CONVEYING BELT TENSION AND ALIGNMENT**

A contoured belt with molded flights is used to convey material along the frame. The tension and alignment of the belt should be checked weekly, or more often if required, to be sure that it does not slip or run to one side. A properly tensioned belt will not slip when it is operating. Operating the belt with less slippage will increase the belt life and causes less stress on bearings, pulleys and shafts.

To maintain the belt, follow this procedure:

**NOTICE** Place all controls in neutral or off, stop motor and disable power source before working on belt.

1. Use the take-up bolts located at the tail to set the tension of the belting.
2. If the belt needs to be tightened to prevent slippage, use the take-up adjustments on the tail end only.
3. The belt is tightened by turning both take-up adjustments an **equal** number of turns.
4. Use the drive roller to check the alignment. The belt should be centered.
5. Turn the belt 1/2 revolution when the belt is new and check the drive and tail roller. If out of alignment, the belt will move to the loose side. Loosen the jam nut on the bearing position bolts and adjust those bolts to set the position of the belt. Once the alignment is set, tighten the jam nuts.
6. Run and check again. Check frequently during the first few minutes of operation and then several times during the first 10 hours. The belt normally seats itself during the first 10 hours of operation and can be checked weekly after that.
7. The belt is properly aligned when the belt runs in the center of the head and tail rollers.

*Loosen this jam nut before adjusting the bearing position bolt*

*Use this bolt to tighten and align the belt*

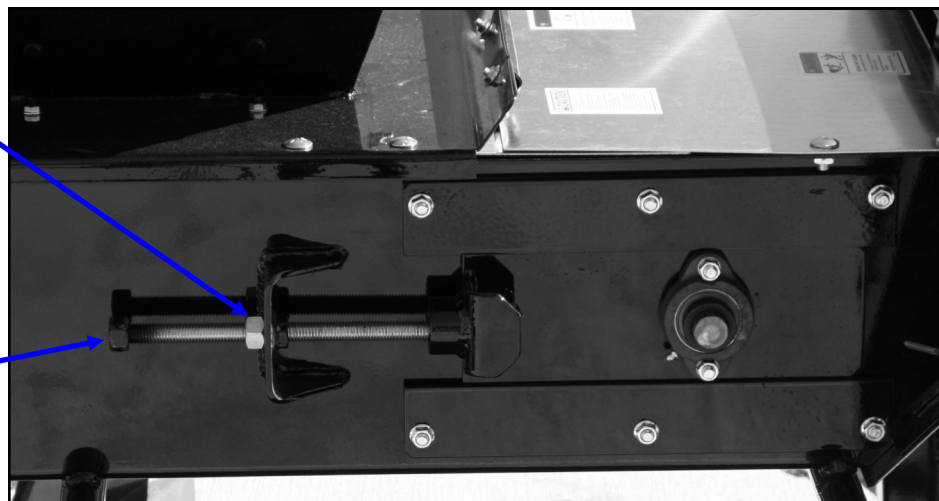

### **CONVEYING BELT ALIGNMENT**

1. A misaligned belt will track toward the loose side. Set the tracking by loosening the bearing mounts on the tight side and using the bearing position bolt to move the end of the head roller toward the tail. Tighten the bearing mount when the belt is centered on the head roller.
2. Run the belt and check the tracking again. Loosen the tight side slightly again if required. Repeat the adjusting and checking procedure until the belt centers on the input end roller and remains centered when running.
3. Always repeat this aligning procedure when installing a new belt. Check frequently during the first 10 hours of operation. After 10 hours, the belt is normally seated and checking the alignment can be done less frequently.



*Loosen bearings*



*Adjusting tracking*

---

### **BELT REPLACEMENT**

1. Rotate the belt until the seam is visible.
2. Move the tail roller to its loosest position.
3. Pull all the slack to the seam area.
4. Remove the wire connector and open the belt.
5. Attach one end of the replacement belt to the belt end being removed.
6. Pull the old belt out and the new belt will be threaded into place.
7. Disconnect the old belt.
8. Connect the ends of the new belt together and secure.
9. Set the belt tension.
10. Check and set the belt alignment

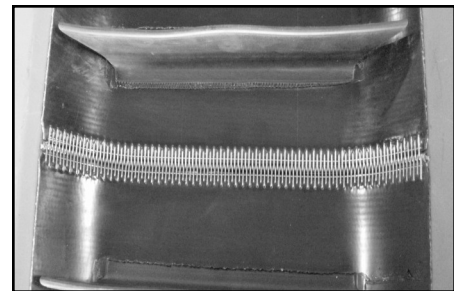

*Belt Seam*



*Check alignment*

## **DRIVE BELT TENSION & ALIGNMENT**

Power to the conveying belt is transmitted through a V-belt. The V-belt drive system must be maintained at the proper belt tension and pulley alignment to obtain the desired performance and life. When maintaining the belt drive system for the electric drive model, follow this procedure:

**NOTICE** Turn motor off and unplug power cord or turn off power and lock out the master panel before starting maintenance on drive belt system.

### **Drive Belt Tension**

1. Push on the center of the belt span with a force of approximately 5 to 10 lbs.
2. The belts will deflect approximately 1/4 to 1/2 inch when properly tensioned.
3. Move the motor up, using the adjustment bolts, to set drive belt tension (right).
4. Close and secure guards.

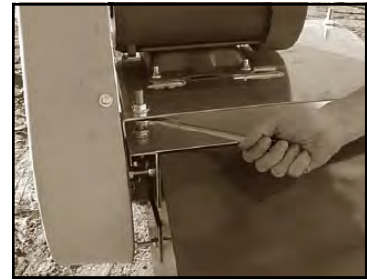

*Motor base adjustment*

### **Drive Belt Alignment**

1. Lay a straightedge across the pulley faces to check the alignment (right).
2. Use the pulley hub or the motor mounting plate slots to move the pulley to the required position for alignment.
3. Tighten hub bolts to secure pulley on shaft.
4. Check belt tension
5. Close and secure guards.



*Lay a straightedge across pulley faces*

### **Drive Belt Replacement**

1. Lower motor to its loosest position.
2. Remove old belt and replace with a new one.
3. Raise motor to set the belt tension.
4. Check pulley alignment. Adjust if required.
5. Close and secure guards.

When storing the USC “S” Series Conveyor for long periods of time, the following procedure must be followed to reduce the chance of rust, corrosion and fatigue of the conveyor. You can also use these steps when storing the machine for the winter.



A dust mask and protective rubber gloves shall be used when cleaning the machine.

1. Clear the area of bystanders, especially small children.
2. Thoroughly wash the entire machine to remove all dirt, mud, debris or residue.
3. Inspect all moving or rotating parts to see if anything has become entangled in them. Remove the entangled material.
4. Lubricate all grease fittings. Make sure that all grease cavities have been filled with grease to remove any water residue from the washing. This also protects the bearing seals.
5. Touch up all paint nicks and scratches to prevent rusting.
6. Move to storage area.
7. Select an area that is dry, level and free of debris.
8. Unhook from towing vehicle.
9. Place blocks under the intake or the jack if required.
10. If the machine cannot be placed inside, cover the electric motor with a water proof tarpaulin and tie securely in place.
11. Store machine in an area away from human activity.
12. Do not allow children to play on or around the stored machine.

SECTION  
H

**MECHANICAL DRAWINGS**

The following pages show the parts for "S" Series Conveyors. Please have the part number ready when ordering parts.

**S2000 PORTABLE CONVEYOR - HEAD SECTION**

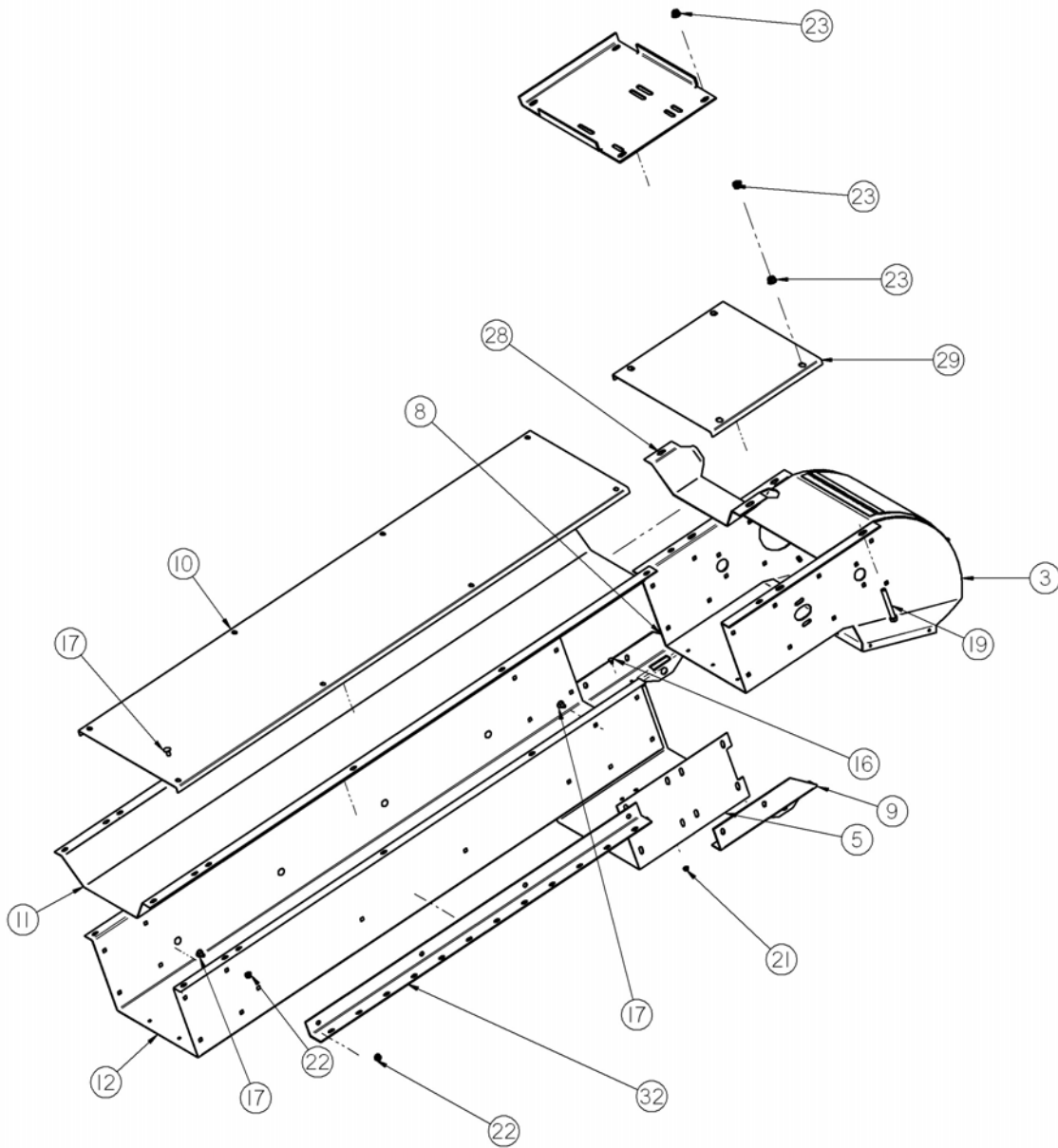

**S2000 PORTABLE CONVEYOR - HEAD SECTION**

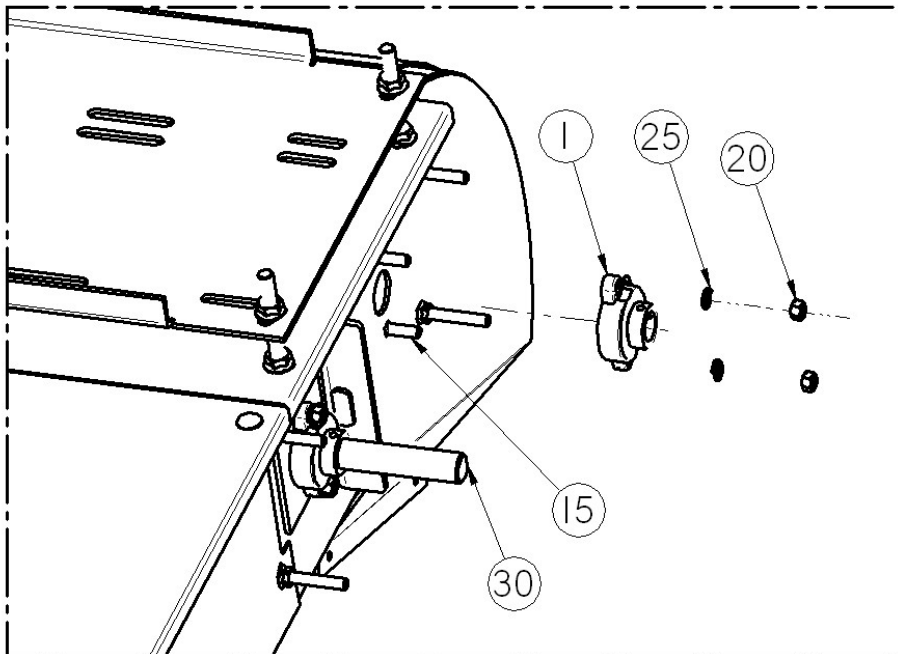
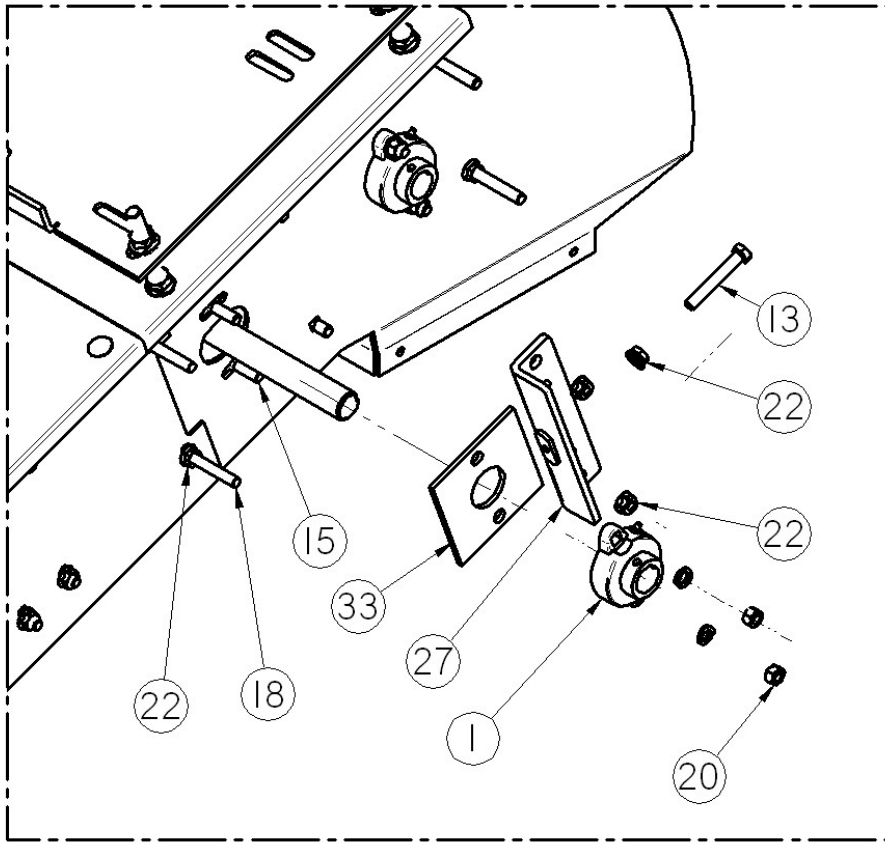

**S2000 PORTABLE CONVEYOR - HEAD SECTION**

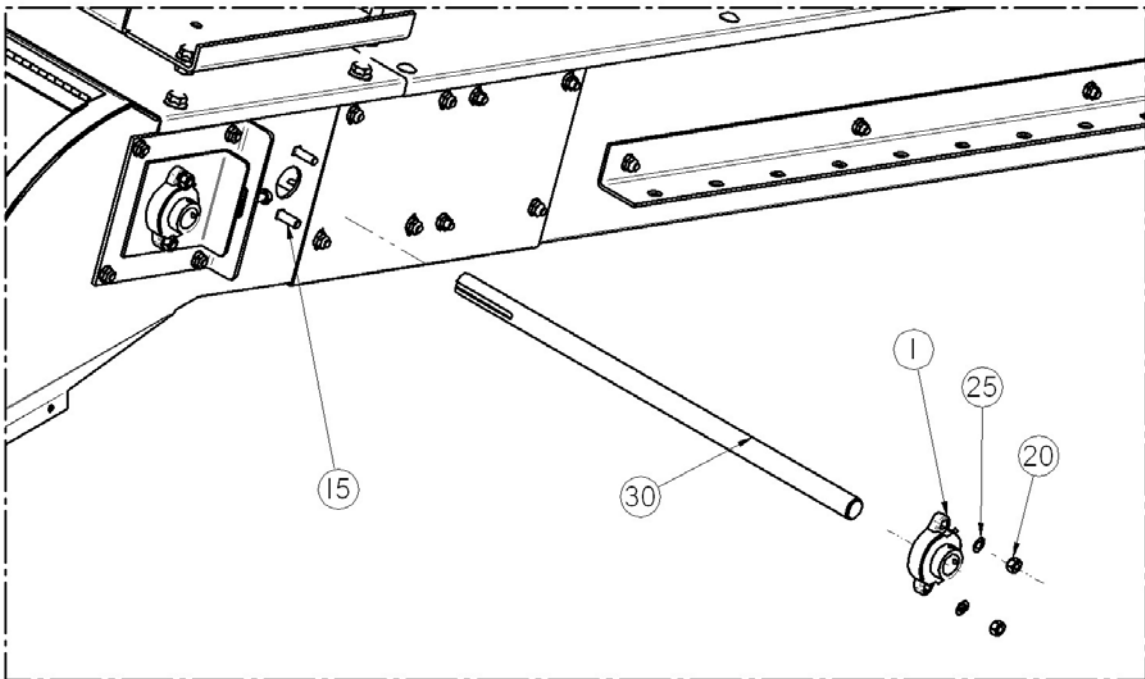
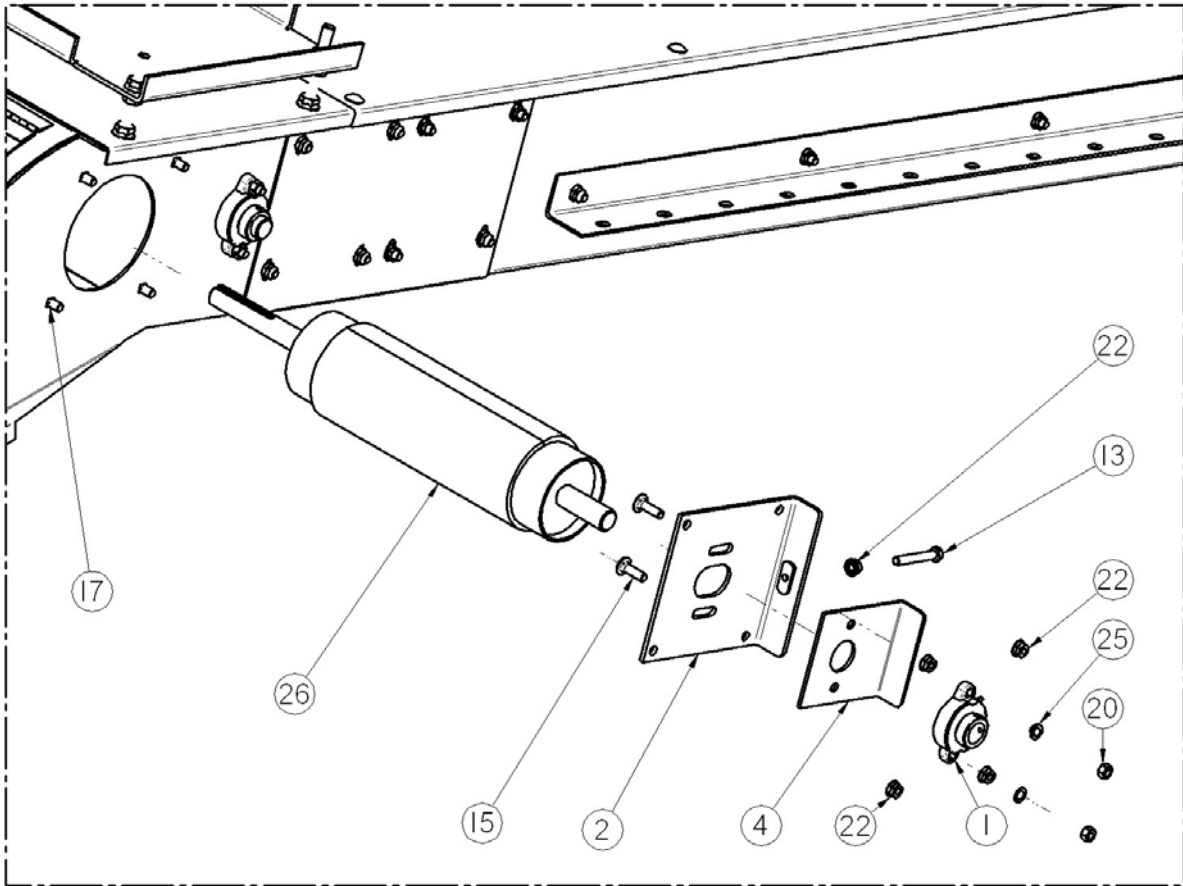



"S" SERIES BELT CONVEYOR

**S2000 PORTABLE CONVEYOR - HEAD SECTION**

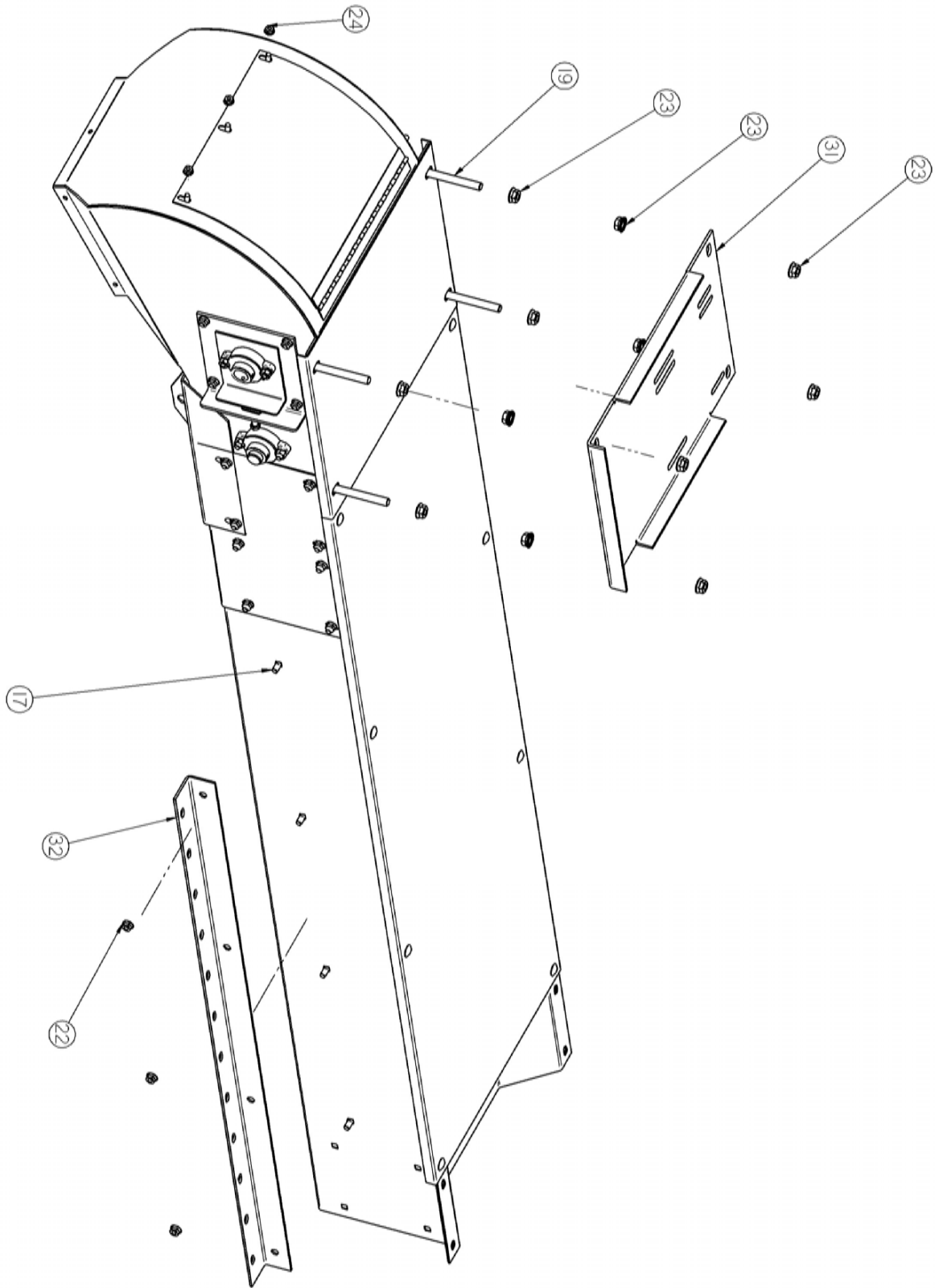

"S" SERIES BELT CONVEYOR

**S2000 PORTABLE CONVEYOR - HEAD SECTION PARTS LIST**

<u>Item #</u>	<u>Part #</u>	<u>Rev</u>	<u>Title</u>	<u>Qty</u>
1	01-03-0042	A	BRG FLG MNT 1.000ID 2BOLT ECNTRC	4
2	05-07-0445	A	WDMT ADJ PLT CNVR HEAD SECT	1
3	05-07-0480	A	WDMT S2000 DSCHG SECT	1
4	05-10-3947	A	PLT BRG ADJ STRIKE	1
5	05-10-3982	A	PLT FORMED SPLICE 16BW HEAD SECT	1
6	05-10-3985	A	PLT S2000 CNVR BLT SCRAPER RBBR	1
7	05-10-3986	A	PLT S2000 CNVR BLT SCRAPER HLDR	1
8	05-10-3987	A	BRKT CNVR PORT TRTR S2000 LT	1
9	05-10-3988	A	BRKT CNVR PORT TRTR S2000 RT	1
10	05-10-3989	A	TOP COVER 7.5FT MID SECTION	1
11	05-10-3990	A	TROUGH PAN 16BW 7.5FT HEAD SECT	1
12	05-10-3991	A	FR 16BW HEAD SECT 7.5FT SPLICED	1
13	06-01-0071	A	BOLT, .375-16 X 2 1/2 ZP G5 FULL THREAD	3
14	06-01-0122	A	BOLT, CARRIAGE, .250-20x.75 G5 ZP	5
15	06-01-0127	A	BOLT, CARRIAGE, .375-16 X 1 1/4 ZP G5	8
16	06-01-0150	A	BOLT, CARRIAGE, .250-20x.50 G5 ZP	6
17	06-01-0153	A	BOLT CRG .375-16X.750 ZP SHORT NECK	36
18	06-01-0154	A	BOLT CRG .375-16 X 2.50 FTH ZP GR5	4
19	06-01-0157	A	BOLT, .500-13 X 4" UNC ZP GRADE 5 fth	4
20	06-02-0003	A	NUT FULL .375-16 ZP GR5	8
21	06-03-0013	A	NUT,LOCK, FLG .250-20 ZP SERRATED	11
22	06-03-0014	A	NUT LOCK FLG .375-16 ZP GR5	42
23	06-03-0015	A	NUT LOCK FLG .500-13 ZP GR5	13
24	06-03-0019	A	NUT LOCK FLG .3125-18 ZP GR5	3
25	06-04-0003	A	WSHR LOCK SPLT .375 ZP	8
26	280-2-0014	A	15.5 X 4 HEAD PULLEY WELDMENT	1
27	280-2-0016	A	TRACKING ANGLE WELDMENT	1
28	280-3-0010	A	TROUGH TRANSITION PLATE	1
29	280-3-0036	B	TOP COVER DISCHARGE	1
30	280-3-0048	A	24 X 1 INCH JACK-HEAD SHAFT	1
31	280-3-0052	B	MOTOR MOUNT	1
32	280-3-0057	A	TRANSPORT STOP PLATE	2
33	280-3-0112	A	BEARING SPACER PLATE	1

"S" SERIES BELT CONVEYOR

**S2000 CONVEYOR - 10 FT MID SECTION & PARTS LIST**

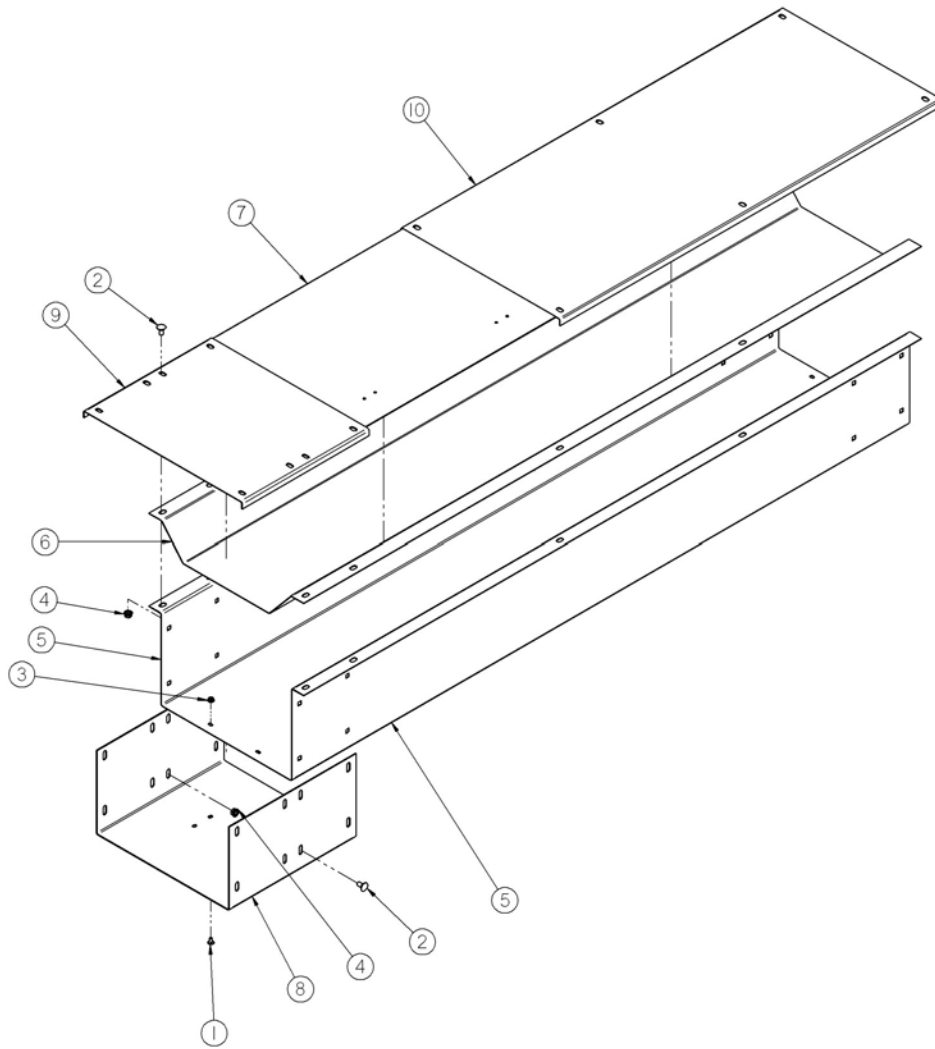

Item #	Part #	Rev	Title	Qty
1	06-01-0150	A	BOLT, CARRIAGE, .250-20x.50 G5 ZP	4
2	06-01-0153	A	BOLT CRG .375-16X.750 ZP SHORT NECK	24
3	06-03-0013	A	NUT,LOCK, FLG .250-20 ZP SERRATED	4
4	06-03-0014	A	NUT LOCK FLG .375-16 ZP GR5	24
5	1020EA	A	FR 16BW TAIL SECT	1
6	1020EB	A	TROUGH PAN 16BW TAIL SECT	1
7	280-2-0046	B	REMOVABLE COVER ASSEMBLY	1
8	280-3-0011	B	SPLICE PLATE-FORMED	1
9	280-3-0012	A	SPLICE COVER	1
10	280-3-0080	B	TOP COVER 4FT	1

"S" SERIES BELT CONVEYOR

**S2000 CONVEYOR - TAIL SECTION**

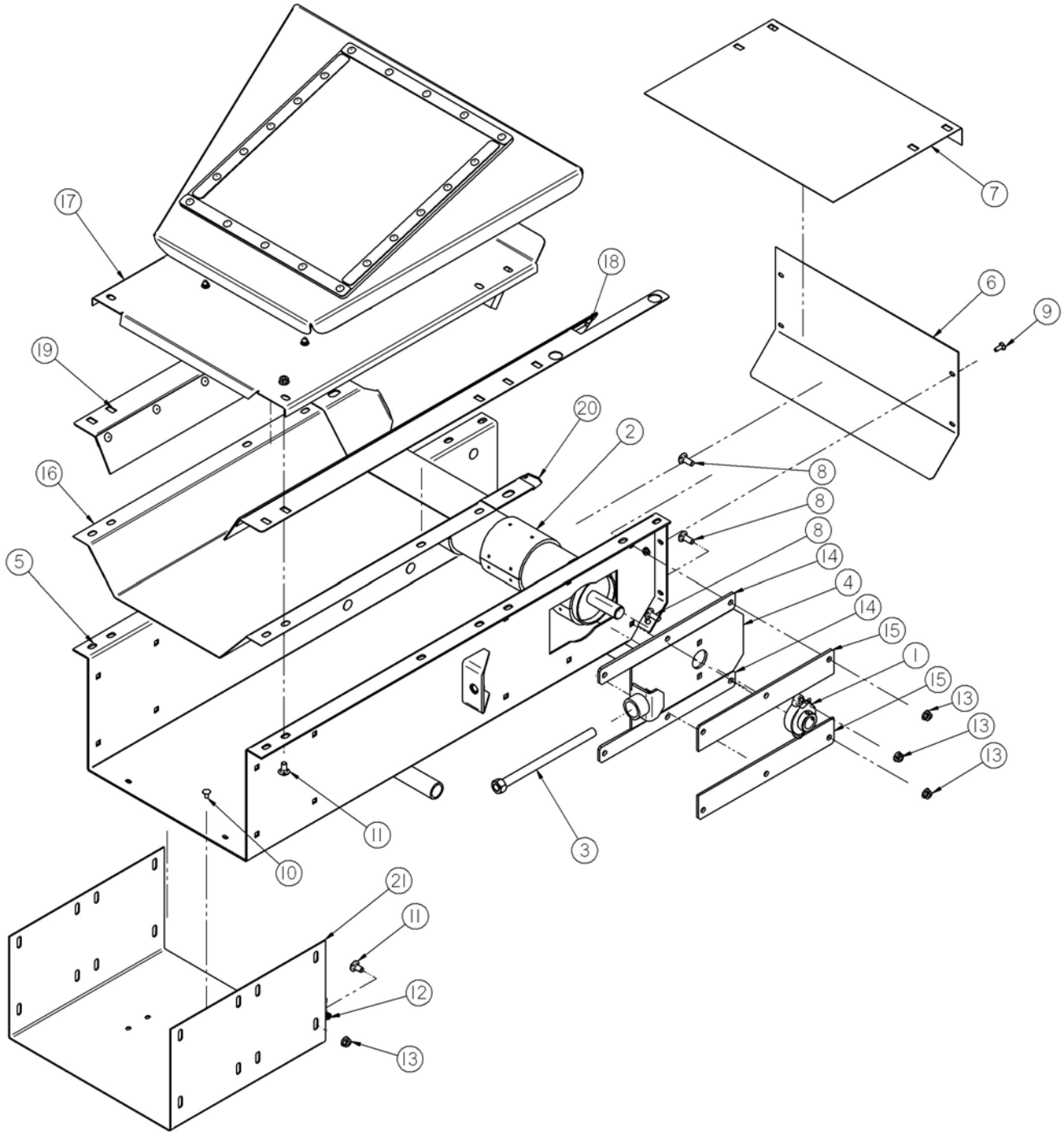

"S" SERIES BELT CONVEYOR

**S2000 CONVEYOR - TAIL SECTION PARTS LIST**

<u>Item #</u>	<u>Part #</u>	<u>Rev</u>	<u>Title</u>	<u>Qty</u>
1	01-03-0042	A	BRG FLG MNT 1.000ID 2BOLT ECNTRC	2
2	01-06-0052	A	15.5 X 4 TAIL PULLEY WELDMENT	1
3	05-03-0493	A	WDMT TENSION ADJUSTER BOLT 10 IN	2
4	05-07-0425	A	WDMT TAKE UP BRG PLT	2
5	05-07-0438	A	WDMT INLET SECT HSG S2000	1
6	05-10-3938	A	PLT S2000 HEAD SECT CLEAN OUT DOOR	1
7	05-10-3939	A	PLT S2000 HEAD SECT END CVR TOP	1
8	06-01-0115	A	BOLT CRG .375-16 X 1.00 ZP GR5	16
9	06-01-0122	A	BOLT, CARRIAGE, .250-20x.75 G5 ZP	4
10	06-01-0150	A	BOLT, CARRIAGE, .250-20x.50 G5 ZP	6
11	06-01-0153	A	BOLT CRG .375-16X.750 ZP SHORT NECK	28
12	06-03-0013	A	NUT,LOCK, FLG .250-20 ZP SERRATTED	10
13	06-03-0014	A	NUT LOCK FLG .375-16 ZP GR5	44
14	10203B	A	SPACER	4
15	10203C	A	SPACER	4
16	10120E9	A	TROUGH PAN 16BW TAIL SECT	1
17	13-08-0015	B	ASSY S2000 CNVR INLT HOPP	1
18	280-2-0026D	D	SKIRTING ASSY LH	1
19	280-2-0027D	D	SKIRTING ASSY RH	1
20	280-3-0010	A	TROUGH TRANSITION PLATE	1
21	280-3-0011	B	SPLICE PLATE-FORMED	1

“S” SERIES BELT CONVEYOR

**S2000 CONVEYOR 2016**

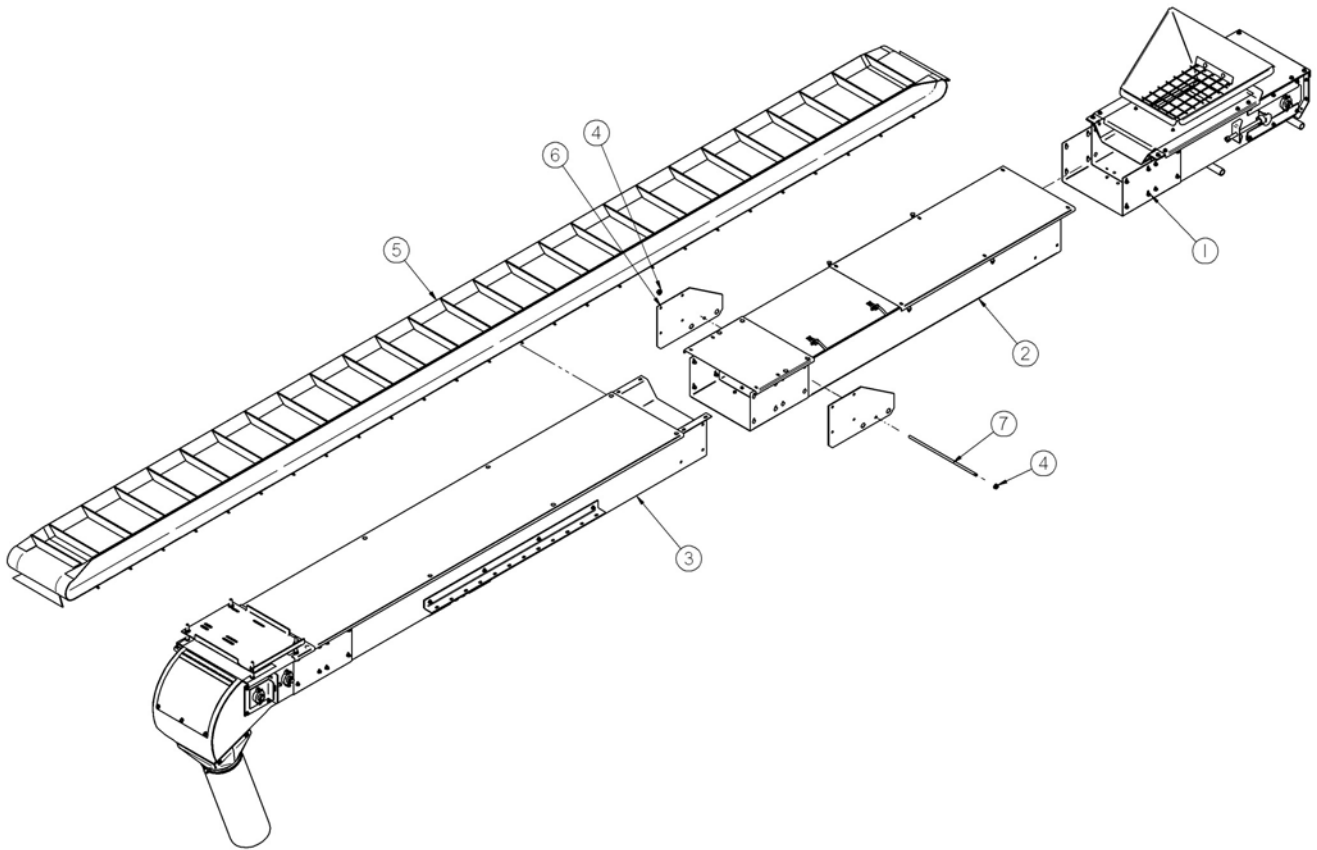

<u>Item #</u>	<u>Part #</u>	<u>Title</u>	<u>Qty</u>
1	05-07-0437	ASSY CNVR 16IN HD INLET SECT	1
2	05-07-0439	ASSY CNVR 16IN HD INLET 10FT EXT	1
3	05-07-0481B	ASSY HEAD SECT 16IN SPLICED LESS DRV	1
4	06-03-0015	NUT LOCK FLG .500-13 ZP GR5	2
5	11-02-0023	BELT CNVR CLTS 2016	1
6	280-3-0103	TRANSPORT MOUNT PLATE-OFFSET	2
7	280-3-0114	THREADED ROD CROSS SUPPORT	1

"S" SERIES BELT CONVEYOR

**S2000 CONVEYOR 2516**

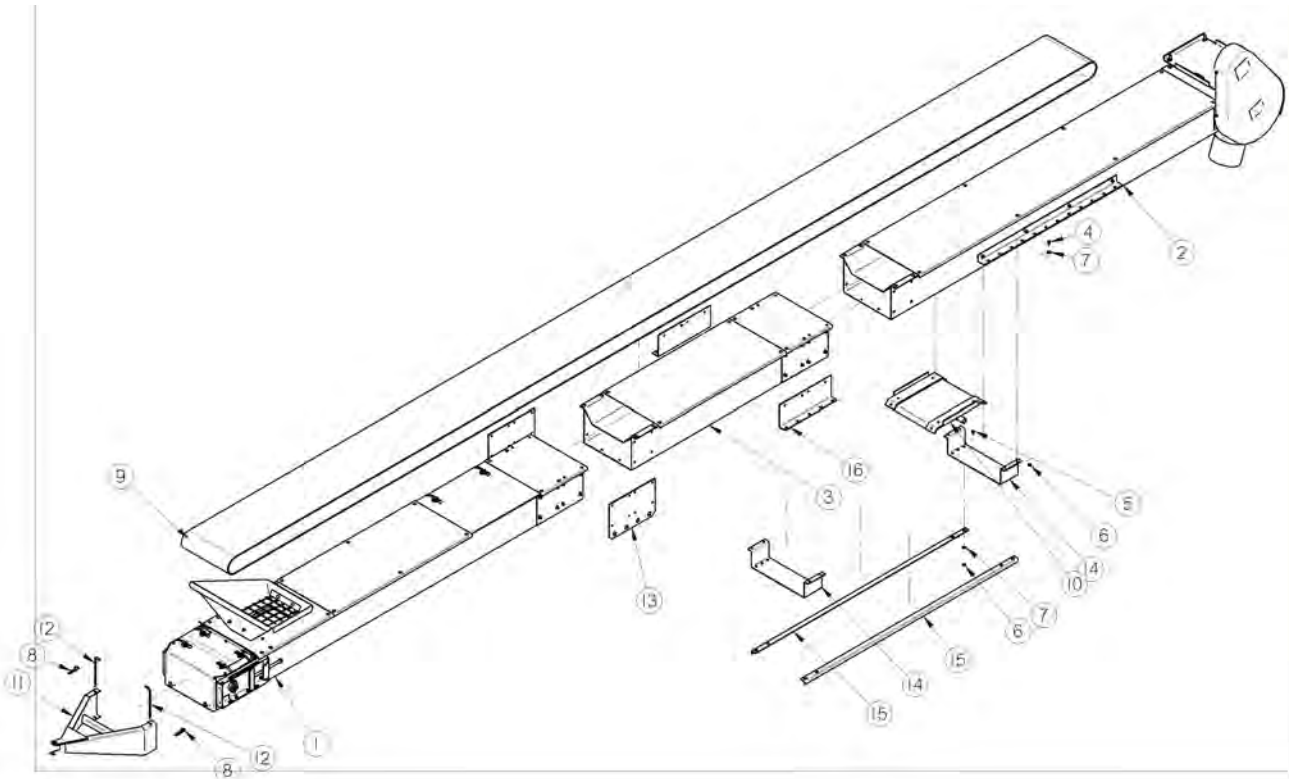

<u>Item #</u>	<u>Part #</u>	<u>Rev</u>	<u>Title</u>	<u>Qty</u>
1	05-07-0267	A	ASSY CNVR 16IN TAIL SECT	1
2	05-07-0268	A	ASSY CNVR 16IN HEAD SECT	1
3	05-07-0270	A	ASSY CNVR 16IN 5FT MID SECT	1
4	06-01-0015	A	BOLT .375-16 X 0.75 ZP GR5	8
5	06-01-0153	A	BOLT CRG .375-16X.750 ZP SHORT NECK	6
6	06-03-0014	A	NUT,LOCK, FLG .375-16 ZP SERRATED	14
7	06-05-0004	A	WSHR FLAT .375 ZP	14
8	06-09-0002	A	PIN CLIP HITCH 3.063 SIZE 9 ZP	2
9	11-02-0022	A	BELT CNVR CLTS 2516	1
10	280-2-0010	B	TRANSPORT SLIDE ASSEMBLY	1
11	280-2-0059	A	HITCH WELDMENT S2000	1
12	280-3-0064	A	HITCH PIN	2
13	280-3-0081	A	TRANSPORT MOUNT PLATE	2
14	280-3-0082	A	TRANSPORT SLIDE STOP	2
15	280-3-0089	A	TRANSPORT SLIDE TRAP	2
16	280-3-0090	A	SAFETY BRACKET STOP MOUNT	2

“S” SERIES BELT CONVEYOR

**S2000 CONVEYOR 3016**

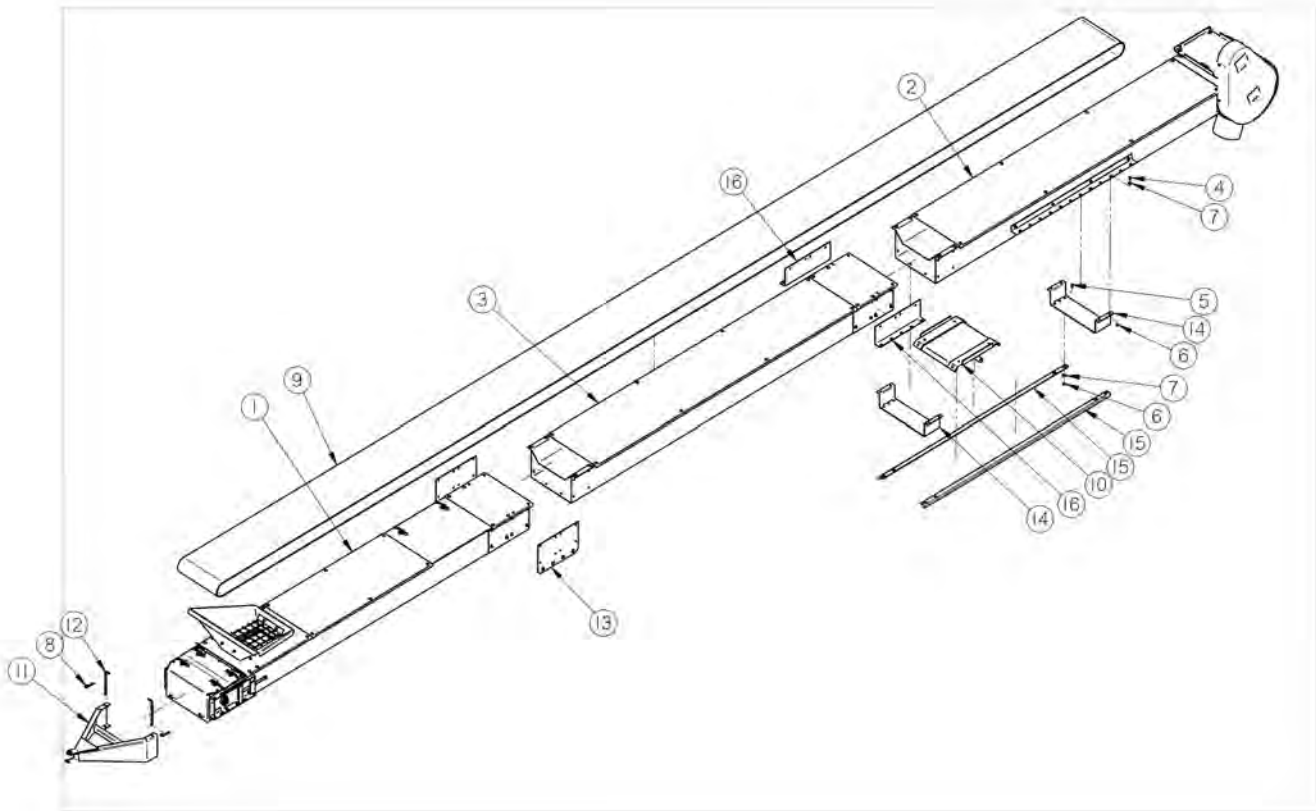

<u>Item #</u>	<u>Part #</u>	<u>Rev</u>	<u>Title</u>	<u>Qty</u>
1	05-07-0267	A	ASSY CNVR 16IN TAIL SECT	1
2	05-07-0268	A	ASSY CNVR 16IN HEAD SECT	1
3	05-07-0269	A	ASSY CNVR 16IN 10FT MID SECT	1
4	06-01-0015	A	BOLT .375-16 X 0.75 ZP GR5	8
5	06-01-0153	A	BOLT CRG .375-16X.750 ZP SHORT NECK	8
6	06-03-0014	A	NUT,LOCK, FLG .375-16 ZP SERRATED	16
7	06-05-0004	A	WSHR FLAT .375 ZP	16
8	06-09-0039	A	.125 Hitch Pin Clip	2
9	11-02-0021	A	BELT CNVR CLTS 3016	1
10	280-2-0010	B	TRANSPORT SLIDE ASSEMBLY	1
11	280-2-0059	A	HITCH WELDMENT S2000	1
12	280-3-0064	A	HITCH PIN	2
13	280-3-0081	A	TRANSPORT MOUNT PLATE	2
14	280-3-0082	A	TRANSPORT SLIDE STOP	2
15	280-3-0089	A	TRANSPORT SLIDE TRAP	2
16	280-3-0090	A	SAFETY BRACKET STOP MOUNT	2



“S” SERIES BELT CONVEYOR

**S2000 CONVEYOR 3516**

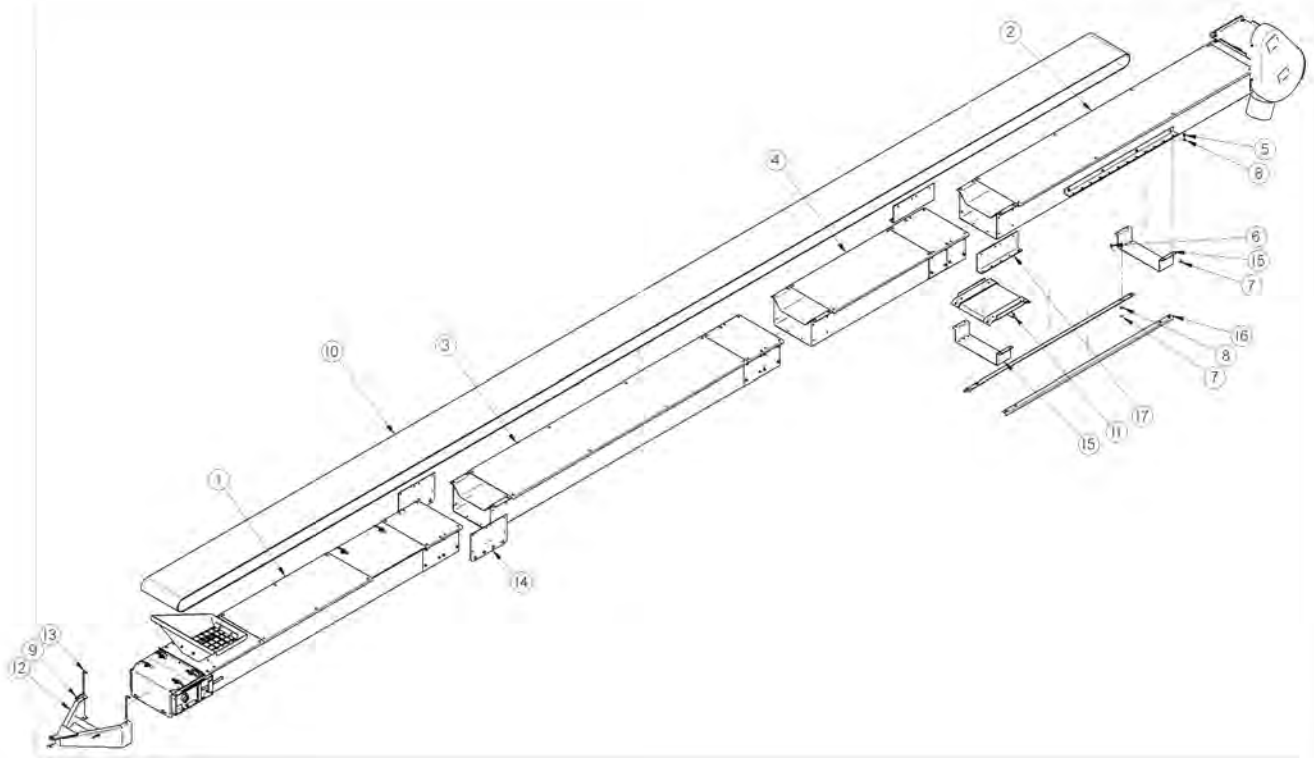

Item #	Part #	Rev	Title	Qty
1	05-07-0267	A	ASSY CNVR 16IN TAIL SECT	1
2	05-07-0268	A	ASSY CNVR 16IN HEAD SECT	1
3	05-07-0269	A	ASSY CNVR 16IN 10FT MID SECT	1
4	05-07-0270	A	ASSY CNVR 16IN 5FT MID SECT	1
5	06-01-0015	A	BOLT .375-16 X 0.75 ZP GR5	8
6	06-01-0153	A	BOLT CRG .375-16X.750 ZP SHORT NECK	6
7	06-03-0014	A	NUT,LOCK, FLG .375-16 ZP SERRATED	14
8	06-05-0004	A	WSHR FLAT .375 ZP	14
9	06-09-0039	A	.125 Hitch Pin Clip	2
10	11-02-0019	A	BELT CNVR CLTS 3516	1
11	280-2-0010	B	TRANSPORT SLIDE ASSEMBLY	1
12	280-2-0059	A	HITCH WELDMENT S2000	1
13	280-3-0064	A	HITCH PIN	2
14	280-3-0081	A	TRANSPORT MOUNT PLATE	2
15	280-3-0082	A	TRANSPORT SLIDE STOP	2
16	280-3-0089	A	TRANSPORT SLIDE TRAP	2
17	280-3-0090	A	SAFETY BRACKET STOP MOUNT	2

“S” SERIES BELT CONVEYOR

**S2000 CONVEYOR 4016**

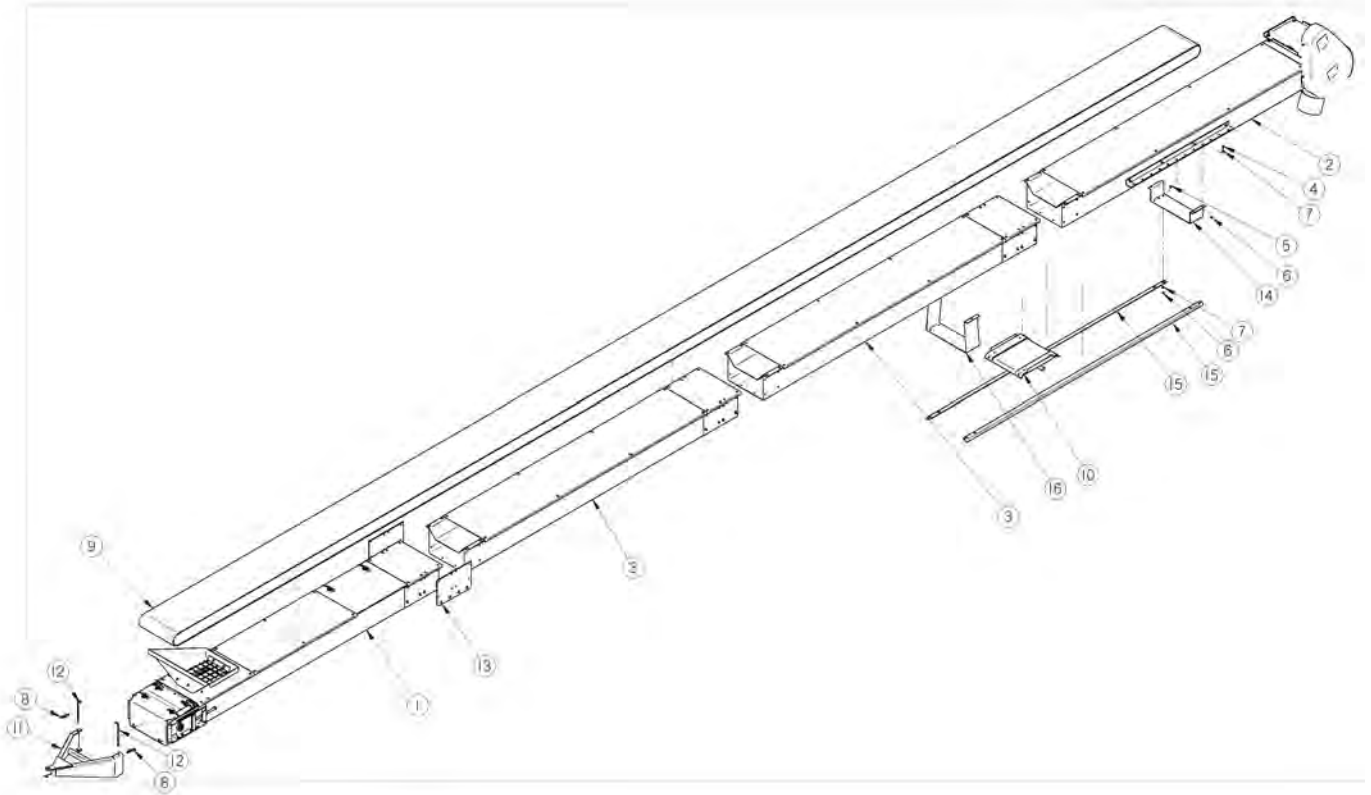

<u>Item #</u>	<u>Part #</u>	<u>Rev</u>	<u>Title</u>	<u>Qty</u>
1	05-07-0267	A	ASSY CNVR 16IN TAIL SECT	1
2	05-07-0268	A	ASSY CNVR 16IN HEAD SECT	1
3	05-07-0269	A	ASSY CNVR 16IN 10FT MID SECT	2
4	06-01-0015	A	BOLT .375-16 X 0.75 ZP GR5	4
5	06-01-0153	A	BOLT CRG .375-16X.750 ZP SHORT NECK	8
6	06-03-0014	A	NUT,LOCK, FLG .375-16 ZP SERRATTED	12
7	06-05-0004	A	WSHR FLAT .375 ZP	12
8	06-09-0002	A	PIN CLIP HITCH 3.063 SIZE 9 ZP	2
9	11-02-0025	A	BELT CNVR CLTS 4016	1
10	280-2-0010	B	TRANSPORT SLIDE ASSEMBLY	1
11	280-2-0059	A	HITCH WELDMENT S2000	1
12	280-3-0064	A	HITCH PIN	2
13	280-3-0081	A	TRANSPORT MOUNT PLATE	2
14	280-3-0082	A	TRANSPORT SLIDE STOP	1
15	280-3-0175	A	TRANSPORT SLIDE TRAP 111IN	2
16	280-3-0176	A	TRANSPORT REAR STOP BRACKET	1

“S” SERIES BELT CONVEYOR

**S2000 CONVEYOR 4516**

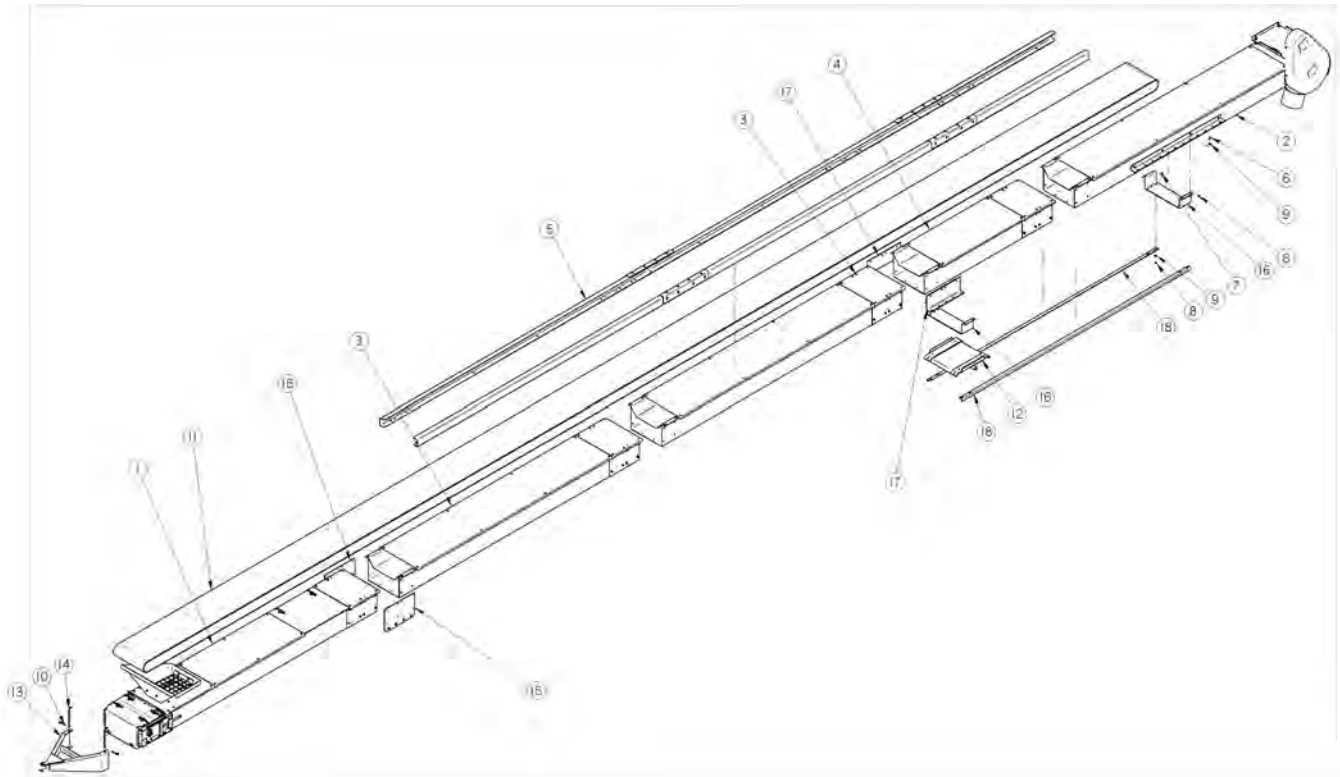

Item #	Part #	Rev	Title	Qty
1	05-07-0267	A	ASSY CNVR 16IN TAIL SECT	1
2	05-07-0268	A	ASSY CNVR 16IN HEAD SECT	1
3	05-07-0269	A	ASSY CNVR 16IN 10FT MID SECT	2
4	05-07-0270	A	ASSY CNVR 16IN 5FT MID SECT	1
5	05-08-0092	A	KIT STRONGBACK 45 FT CNVR	1
6	06-01-0015	A	BOLT .375-16 X 0.75 ZP GR5	8
7	06-01-0153	A	BOLT CRG .375-16X.750 ZP SHORT NECK	6
8	06-03-0014	A	NUT,LOCK, FLG .375-16 ZP SERRATED	14
9	06-05-0004	A	WSHR FLAT .375 ZP	15
10	06-09-0039	A	.125 Hitch Pin Clip	2
11	11-02-0024	A	BELT CNVR CLTS 4516	1
12	280-2-0010	B	TRANSPORT SLIDE ASSEMBLY	1
13	280-2-0059	A	HITCH WELDMENT S2000	1
14	280-3-0064	A	HITCH PIN	2
15	280-3-0081	A	TRANSPORT MOUNT PLATE	2
16	280-3-0082	A	TRANSPORT SLIDE STOP	2
17	280-3-0090	A	SAFETY BRACKET STOP MOUNT	2
18	280-3-0190	A	TRANSPORT SLIDE TRAP 122IN	2

**S2000 FIXED CONVEYOR STAND**

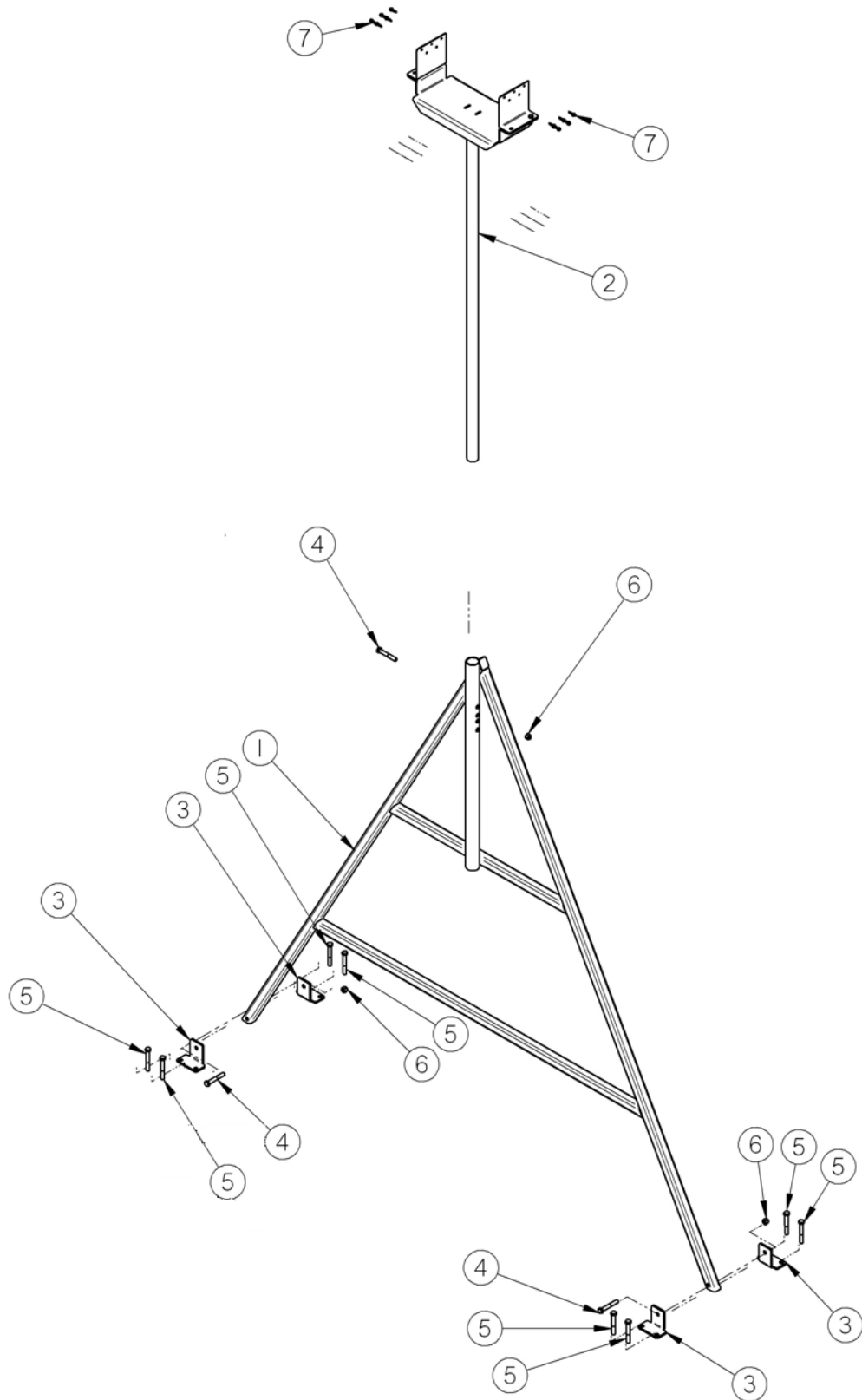

"S" SERIES BELT CONVEYOR

**S2000 FIXED CONVEYOR STAND PARTS LIST**

S2000 STAND HEIGHT (Inches)	68 TO 98	96 TO 132
	Part # 05-05-0021	05-05-0016

<u>Item #</u>	<u>Title</u>	<u>Part #</u>	<u>Qty</u>	<u>Part #</u>	<u>Qty</u>
1	CNVR STAND BASE	05-03-0640	1	05-03-0620	1
2	S2000 STAND TOP ADJ	05-05-0012	1	05-05-0012	1
3	PLT PIVOT CNVR STAND	05-10-3256	4	05-10-3256	4
4	BOLT .500-13 X 3.25 ZP GR5	06-01-0029	3	06-01-0029	3
5	BOLT .500-13 CONC ANCHOR ZP 4.25	06-01-0086	8	06-01-0086	8
6	NUT NYL LOCK .500-13 ZP GR5	06-03-0004	3	06-03-0004	3
7	SCRW SDST .250-14 X 1.000 HH ZP	06-06-0037	10	06-06-0037	10

S2000 STAND HEIGHT (Inches)	132 TO 208	200 TO 296
	Part # 05-05-0030	05-05-0023

<u>Item #</u>	<u>Title</u>	<u>Part #</u>	<u>Qty</u>	<u>Part #</u>	<u>Qty</u>
1	CNVR STAND BASE	05-03-0660	1	05-03-0646	1
2	S2000 STAND TOP ADJ	05-05-0024	1	05-05-0024	1
3	PLT PIVOT CNVR STAND	05-10-3256	4	05-10-3256	4
4	BOLT .500-13 X 3.25 ZP GR5	06-01-0029	3	06-01-0029	3
5	BOLT .500-13 CONC ANCHOR ZP 4.25	06-01-0086	8	06-01-0086	8
6	NUT NYL LOCK .500-13 ZP GR5	06-03-0004	3	06-03-0004	3
7	SCRW SDST .250-14 X 1.000 HH ZP	06-06-0037	10	06-06-0037	10

"S" SERIES BELT CONVEYOR

**S2000 FIXED STAND (0-56 Inches) & PARTS LIST**

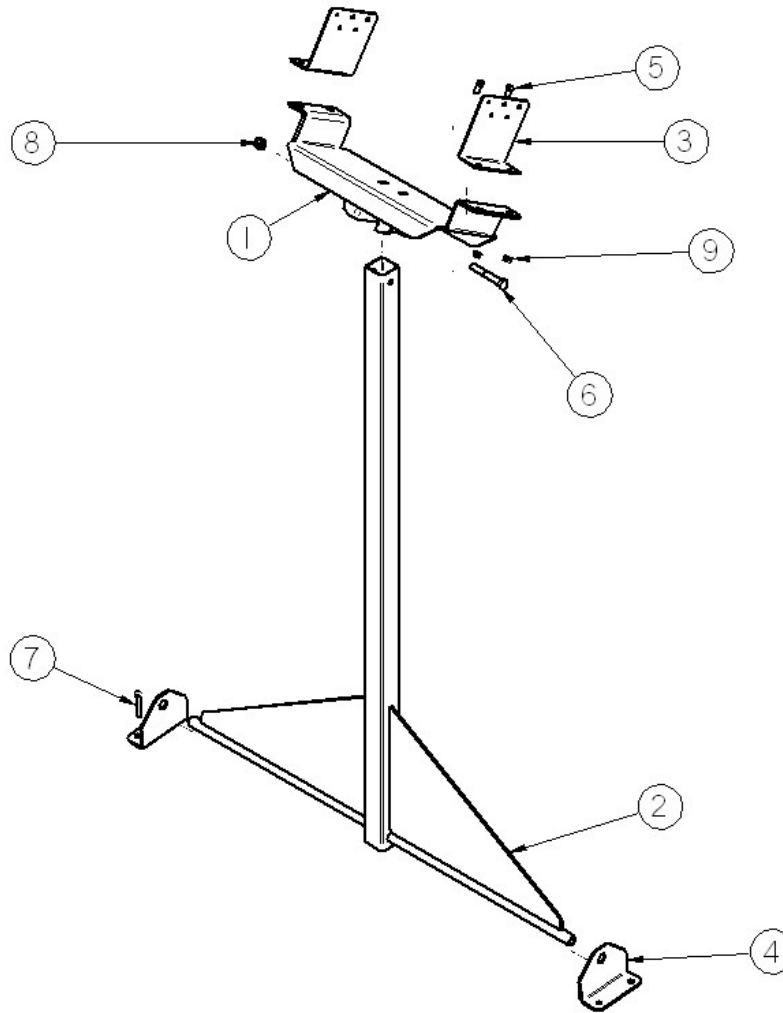

<u>Item #</u>	<u>Part #</u>	<u>Rev</u>	<u>Title</u>	<u>Qty</u>
1	05-03-0500	C	CNVR STAND TOP	1
2	05-03-0850	A	WDMT 15FT S2000 CART SUPP	1
3	05-10-3052	A	PLT CNVR SUPT TOP	2
4	05-10-3628	A	BRKT SUPP MNT CNVR TAIL TALL	2
5	06-01-0015	A	BOLT .375-16 X 0.75 ZP GR5	4
6	06-01-0029	A	BOLT .500-13 X 3.25 ZP GR5	1
7	06-01-0180	A	BOLT, .3125 X 2.5 CONC ANCHOR ZP	4
8	06-03-0004	A	NUT NYL LOCK .500-13 ZP GR5	1
9	06-03-0014	A	NUT LOCK FLG .375-16 ZP GR5	4
10	06-06-0037	A	SCRW SDST .250-14 X 1.000 HH ZP	10

"S" SERIES BELT CONVEYOR

**S2000 PORTABLE CONVEYOR - UNDERCARRIAGE**

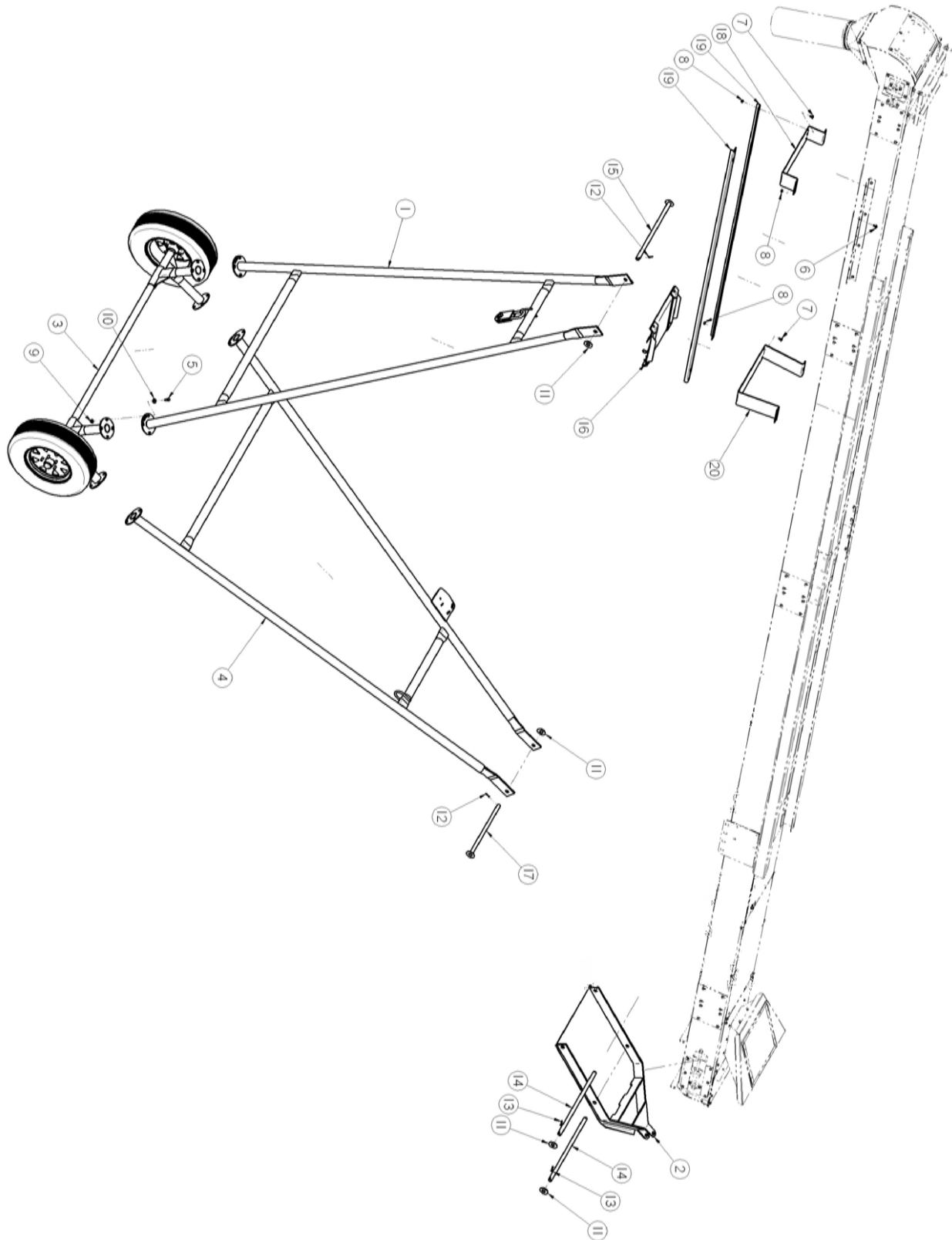

**S2000 PORTABLE CONVEYOR - UNDERCARRIAGE PARTS LIST**

Title	USC MODEL #		USC PART #	
	Part #	Qty	Part #	Qty
UPPER A-FR UNCG	05-07-0446	1	05-07-0447	1
WDMT HITCH 16BW HD	05-07-0489	1	05-07-0489	1
ASSY AXLE SECT UNCG	05-08-0115	1	05-08-0115	1
LOWER A-FRAME UNCG	05-08-0141	1	05-08-0143	1
BOLT .500-13 X 1.25 ZP GR5	06-01-0080	16	06-01-0080	16
BOLT, FLG .375-16 UNC ZP GRADE 5; 3/4" LG	06-01-0124	8	06-01-0124	8
BOLT CRG .375-16X.750 ZP SHORT NECK	06-01-0153	8	06-01-0153	8
NUT LOCK FLG .375-16 ZP GR5	06-03-0014	16	06-03-0014	16
NUT LOCK FLG .500-13 ZP GR5	06-03-0015	16	06-03-0015	16
WSHR FLAT .500 ZP	06-05-0005	16	06-05-0005	16
WASHER, 1.00 FLAT ZP	06-05-0010	6	06-05-0010	6
.125 X 1.50 ZP COTTER PIN	06-09-0018	2	06-09-0018	2
.188 X 2.00 ZP COTTER PIN	06-09-0023	4	06-09-0023	4
HITCH PIN	1022F3	2	1022F3	2
WINCH KITS	13-05-0099	1	13-05-0100	1
SLIDE PIN WELDMENT	280-2-0009	1	280-2-0009	1
TRANSPORT SLIDE ASSEMBLY	280-2-0010	1	280-2-0010	1
TRANSPORT MOUNT PIN WELDMENT 20 IN	280-2-0018	1	280-2-0018	1
TRANSPORT SLIDE STOP	280-3-0082	2	280-3-0082	2
TRANSPORT SLIDE TRAP	280-3-0104	2	280-3-0089	2
TRANSPORT REAR STOP BRACKET	NA		NA	



**S2000 PORTABLE CONVEYOR - UNDERCARRIAGE PARTS LIST**

Item #	Title	USC MODEL #		USC PART #	
		Part #	Qty	Part #	Qty
1	UPPER A-FR UNCG	05-07-0449	1	05-07-0450	1
2	WDMT HITCH 16BW HD	05-07-0489	1	05-07-0489	1
3	ASSY AXLE SECT UNCG	05-08-0115	1	05-08-0115	1
4	LOWER A-FRAME UNCG	05-08-0147	1	05-08-0149	1
5	BOLT .500-13 X 1.25 ZP GR5	06-01-0080	16	06-01-0080	16
6	BOLT, FLG .375-16 UNC ZP GRADE 5; 3/4" LG	06-01-0124	8	06-01-0124	4
7	BOLT CRG .375-16X.750 ZP SHORT NECK	06-01-0153	8	06-01-0153	8
8	NUT LOCK FLG .375-16 ZP GR5	06-03-0014	16	06-03-0014	12
9	NUT LOCK FLG .500-13 ZP GR5	06-03-0015	16	06-03-0015	16
10	WSHR FLAT .500 ZP	06-05-0005	16	06-05-0005	16
11	WASHER, 1.00 FLAT ZP	06-05-0010	6	06-05-0010	6
12	.125 X 1.50 ZP COTTER PIN	06-09-0018	2	06-09-0018	2
13	.188 X 2.00 ZP COTTER PIN	06-09-0023	4	06-09-0023	4
14	HITCH PIN	1022F3	2	1022F3	2
15	WINCH KITS	13-05-0092	1	13-05-0102	1
16	SLIDE PIN WELDMENT	280-2-0009	1	280-2-0009	1
17	TRANSPORT SLIDE ASSEMBLY	280-2-0010	1	280-2-0010	1
18	TRANSPORT MOUNT PIN WELDMENT 20 IN	280-2-0018	1	280-2-0018	1
19	TRANSPORT SLIDE STOP	280-3-0082	2	280-3-0082	2
20	TRANSPORT SLIDE TRAP	280-3-0089	2	280-3-0175	2
21	TRANSPORT REAR STOP BRACKET	NA		280-3-0176	1

USC MODEL #  
USC PART #

3516  
05-08-0157

4016  
05-08-0158

4516  
05-08-0159

"S" SERIES BELT CONVEYOR

**S3000 CONVEYOR - HEAD SECTION**

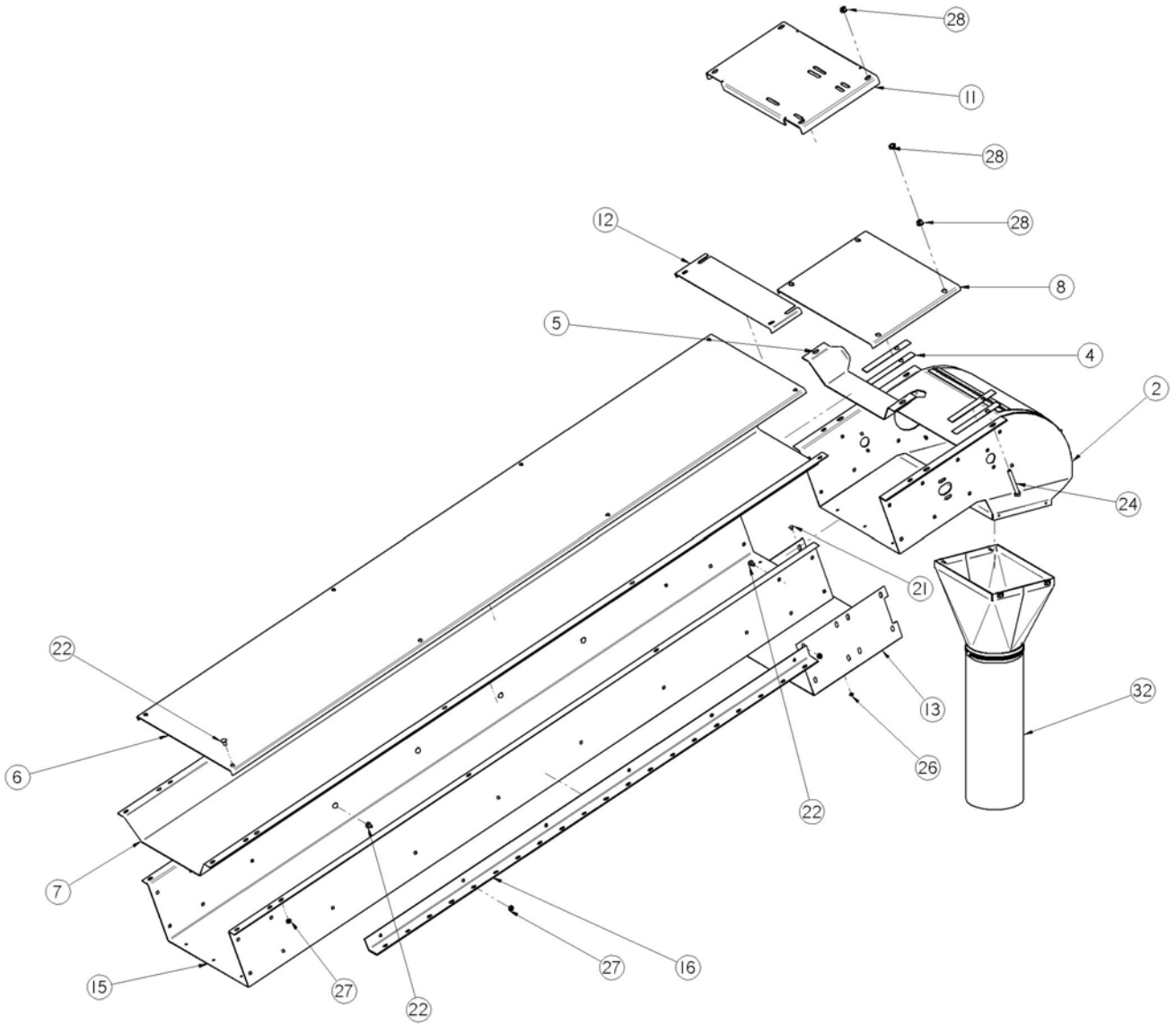

**S3000 CONVEYOR - HEAD SECTION**

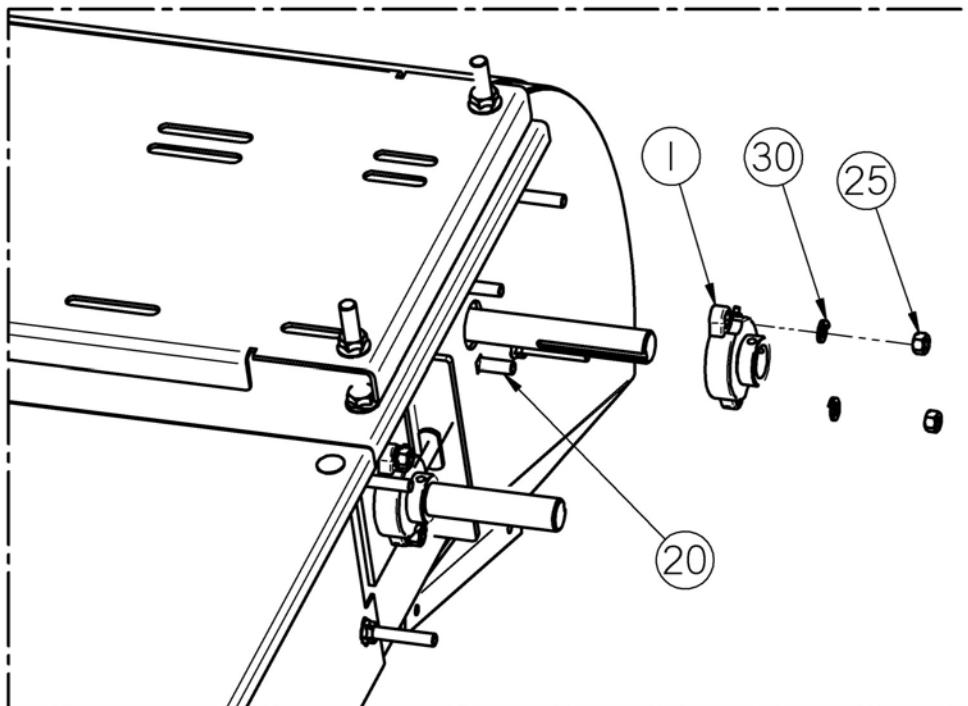
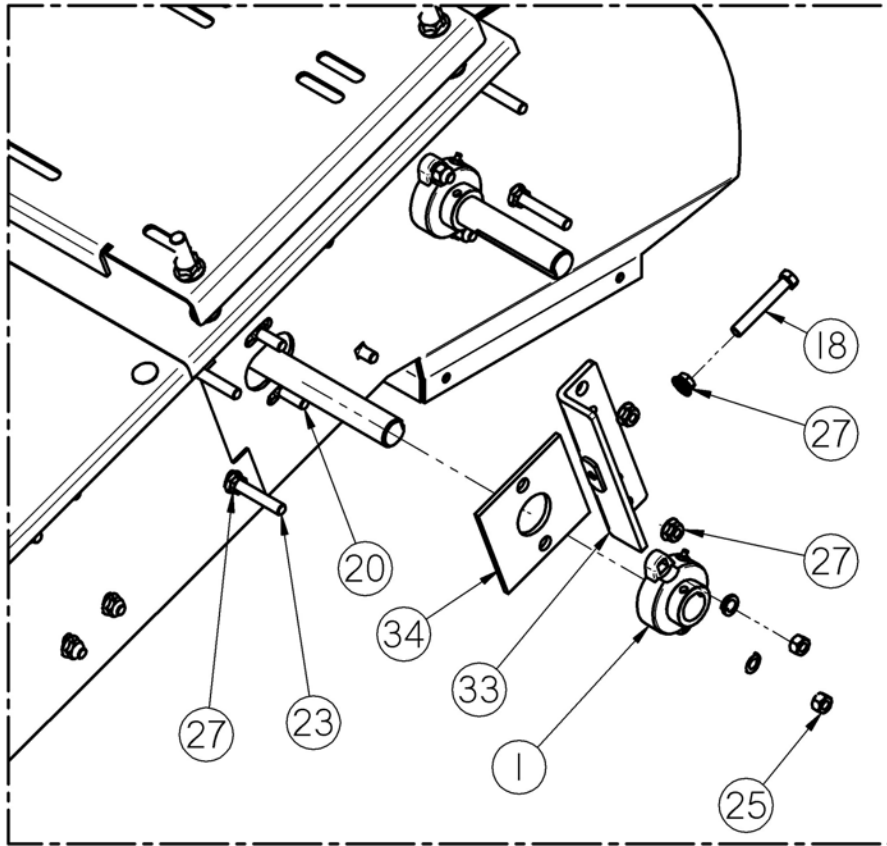

**S3000 CONVEYOR - HEAD SECTION**

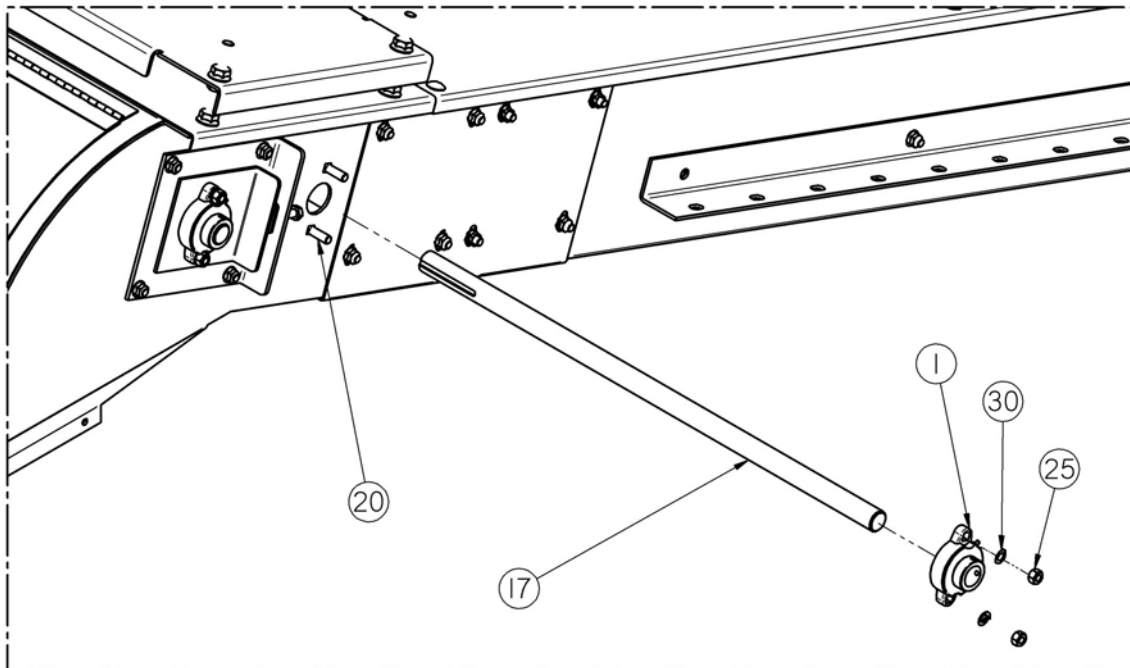
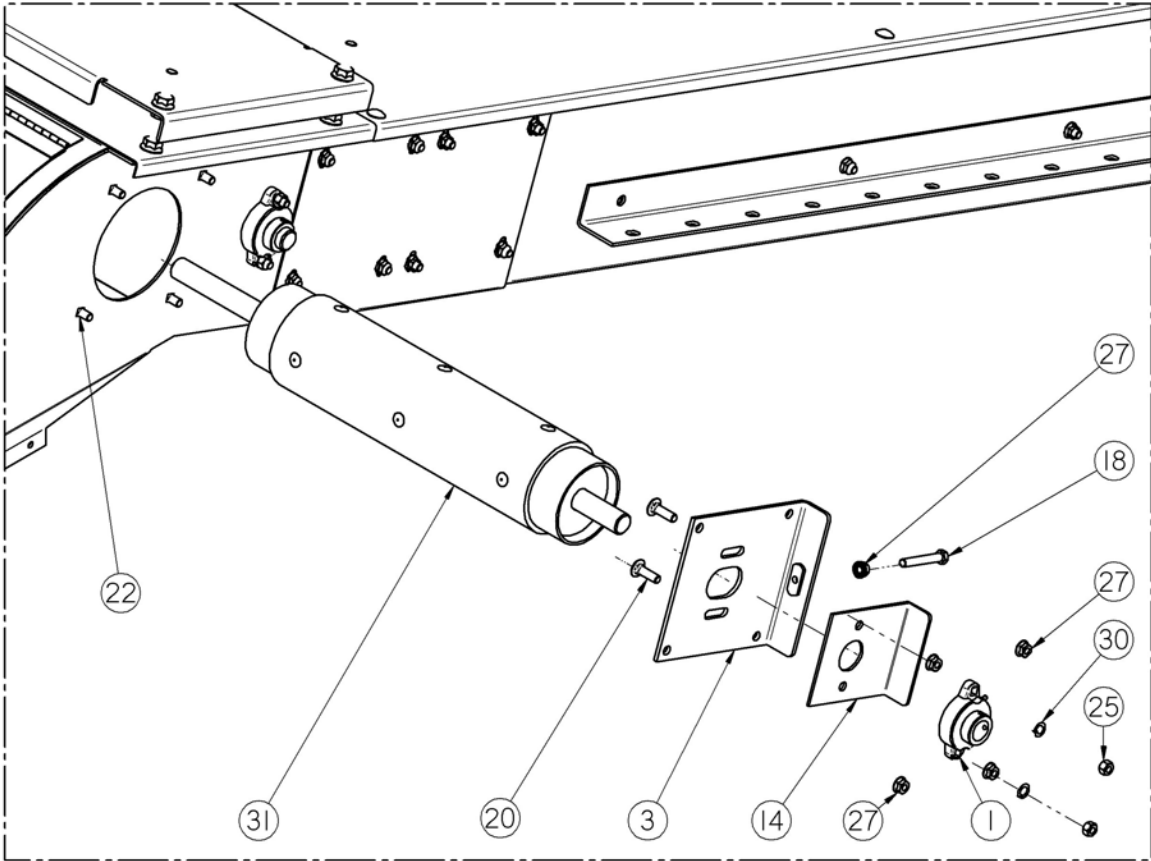

"S" SERIES BELT CONVEYOR

**S3000 CONVEYOR - HEAD SECTION**

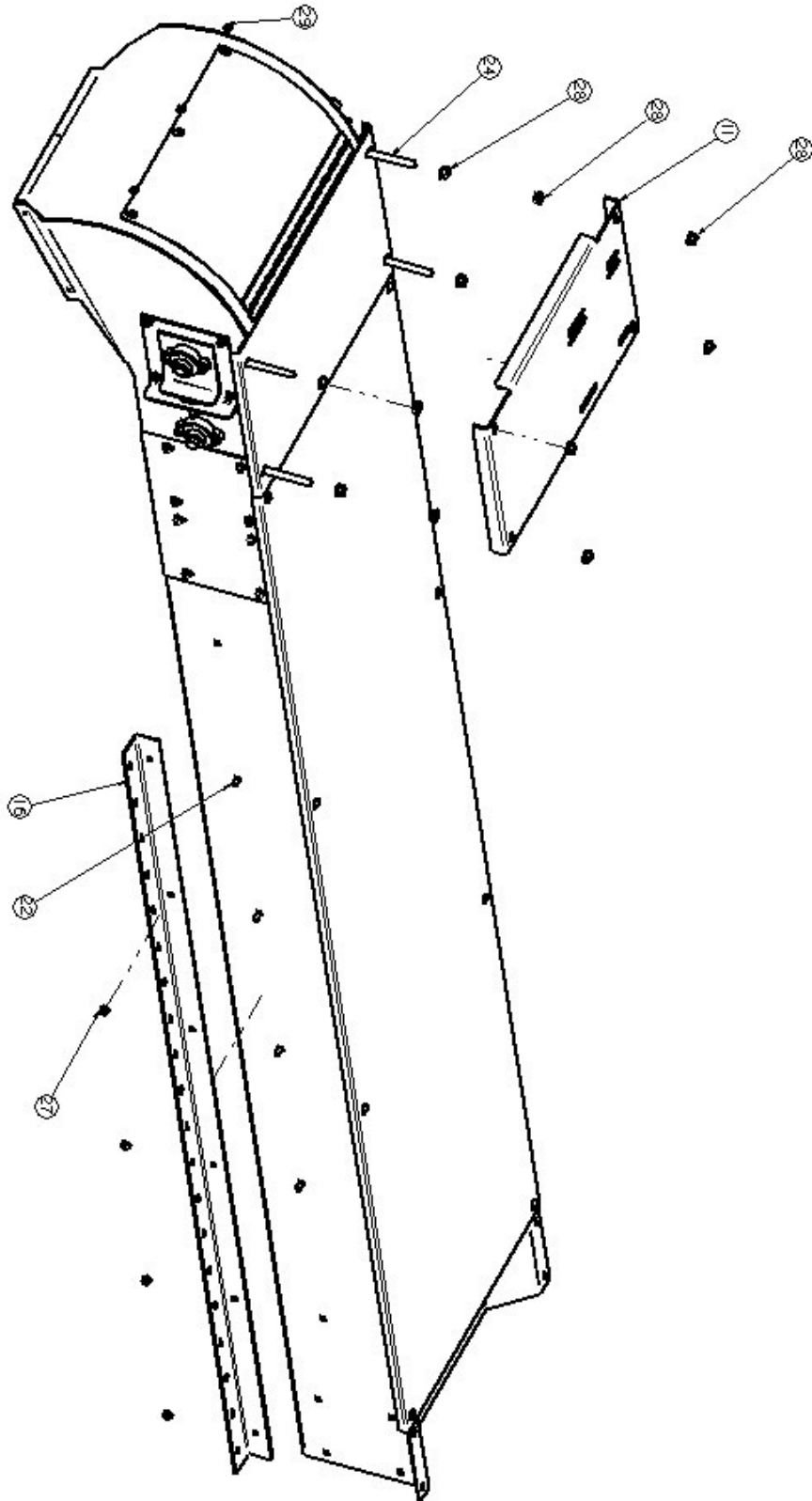

"S" SERIES BELT CONVEYOR

**S3000 CONVEYOR - HEAD SECTION PARTS LIST**

<u>Item #</u>	<u>Part #</u>	<u>Title</u>	<u>Qty</u>
1	01-03-0042	BRG FLG MNT 1.000ID 2BOLT ECNTRC	4
2	05-07-0443	WDMT S3000 DSCHG SECT	1
3	05-07-0445	WDMT ADJ PLT CNVR HEAD SECT	1
4	05-10-3267	SPCR UB HEAD CVR 16GA	4
5	05-10-3828	PLT TROUGH TRANS 20BW	1
6	05-10-3843	PLT TOP CVR 20BW MID SECT	1
7	05-10-3845	TROUGH PAN 20BW HEAD SECT	1
8	05-10-3846	PLT TOP CVR DSCHG 20BW	1
9	05-10-3851	PLT S3000 CNVR BLT SCRAPER RBBR	1
10	05-10-3852	PLT S3000 CNVR BLT SCRAPER HLDR	1
11	05-10-3854	PLT MTR MNT 20BW	1
12	05-10-3856	PLT CNVR SPLICE HEAD CVR S3000	1
13	05-10-3942	PLT FORMED SPLICE 20BW HEAD SECT	1
14	05-10-3947	PLT BRG ADJ STRIKE	1
15	05-10-4027	FR 20BW HEAD SECT 10FT EXT MNT	1
16	05-10-4028	TRANSPORT STOP PLT EXT MNT	2
17	05-11-0310	SHAFT 28 X 1IN JACK HEAD	1
18	06-01-0071	BOLT, .375-16 X 2 1/2 ZP G5 FULL THREAD	2
19	06-01-0122	BOLT, CARRIAGE, .250-20x.75 G5 ZP	3
20	06-01-0127	BOLT, CARRIAGE, .375-16 X 1 1/4 ZP G5	8
21	06-01-0150	BOLT, CARRIAGE, .250-20x.50 G5 ZP	6
22	06-01-0153	BOLT CRG .375-16X.750 ZP SHORT NECK	40
23	06-01-0154	BOLT CRG .375-16 X 2.50 FTH ZP GR5	4
24	06-01-0157	BOLT, .500-13 X 4" UNC ZP GRADE 5 fth	4
25	06-02-0003	NUT FULL .375-16 ZP GR5	8
26	06-03-0013	NUT,LOCK, FLG .250-20 ZP SERRATTED	9
27	06-03-0014	NUT LOCK FLG .375-16 ZP GR5	46
28	06-03-0015	NUT LOCK FLG .500-13 ZP GR5	12
29	06-03-0019	NUT LOCK FLG .3125-18 ZP GR5	3
30	06-04-0003	WSHR LOCK SPLT .375 ZP	8
31	13-05-0204	ASSY HEAD PLY S3000	1
32	13-05-0205	ASSY 6IN SPOUT S3000	1
33	280-2-0016	TRACKING ANGLE WELDMENT	1
34	280-3-0112	BEARING SPACER PLATE	1

"S" SERIES BELT CONVEYOR

**S3000 CONVEYOR - TAIL SECTION**

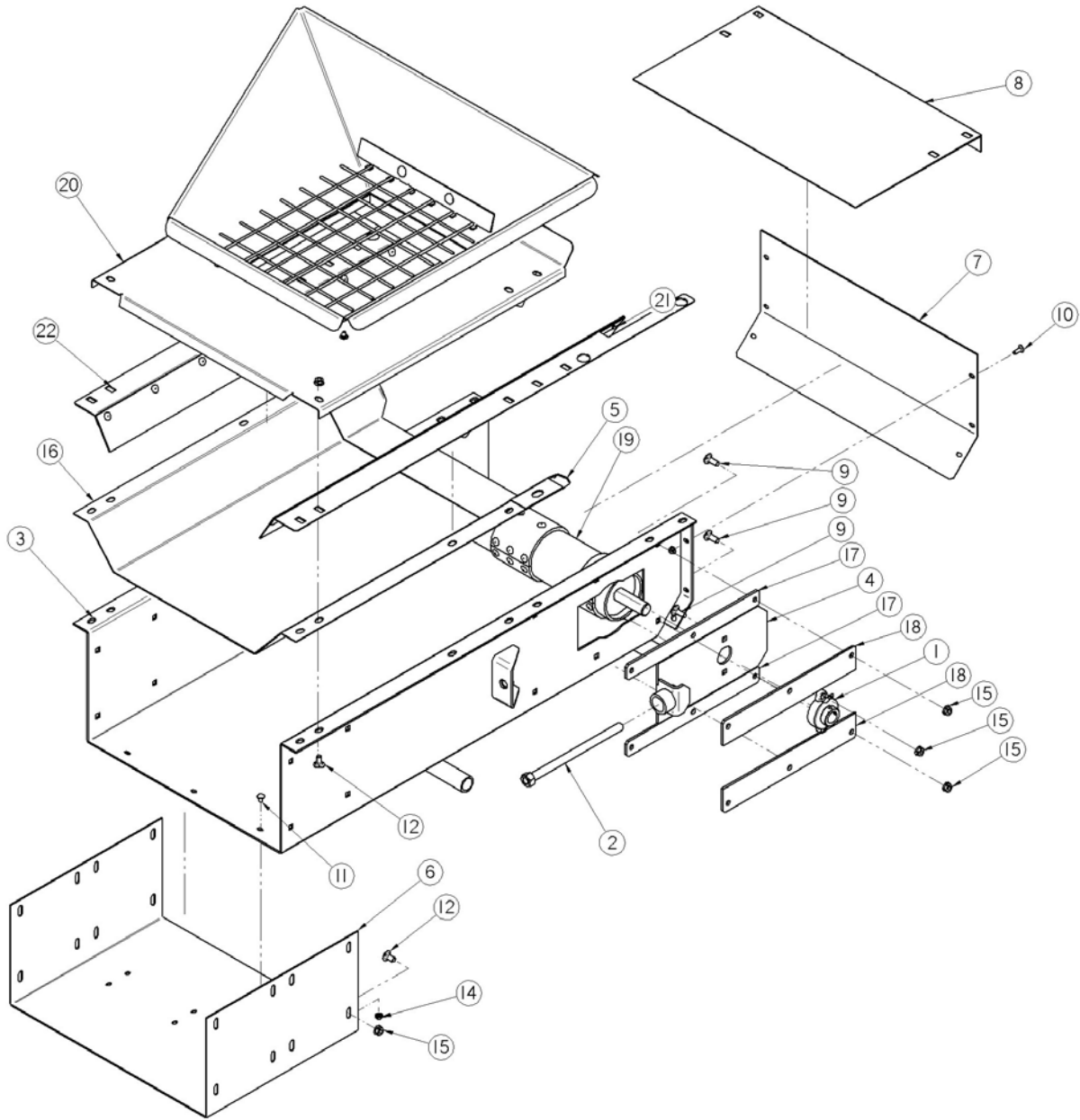

"S" SERIES BELT CONVEYOR

**S3000 CONVEYOR - TAIL SECTION PARTS LIST**

<u>Item #</u>	<u>Part #</u>	<u>Title</u>	<u>Qty</u>
1	01-03-0042	BRG FLG MNT 1.000ID 2BOLT ECNTRC	2
2	05-03-0493	WDMT TENSION ADJUSTER BOLT 10 IN	2
3	05-07-0424	WDMT INLET SECT HSG S3000	1
4	05-07-0425	WDMT TAKE UP BRG PLT	2
5	05-10-3828	PLT TROUGH TRANS 20BW	1
6	05-10-3829	PLT FORMED SPLICE 20BW	1
7	05-10-3902	PLT S3000 TAIL SECT CLEAN OUT DOOR	1
8	05-10-3903	PLT S3000 TAIL SECT END CVR TOP	1
9	06-01-0115	BOLT CRG .375-16 X 1.00 ZP GR5	16
10	06-01-0122	BOLT, CARRIAGE, .250-20x.75 G5 ZP	4
11	06-01-0150	BOLT, CARRIAGE, .250-20x.50 G5 ZP	6
12	06-01-0153	BOLT CRG .375-16X.750 ZP SHORT NECK	28
13	06-02-0005	NUT, .625-11 UNC ZP GRADE 5	2
14	06-03-0013	NUT,LOCK, FLG .250-20 ZP SERRATED	10
15	06-03-0014	NUT LOCK FLG .375-16 ZP GR5	44
16	102034	TROUGH PAN 20BW TAIL SECT	1
17	10203B	SPACER	4
18	10203C	SPACER	4
19	13-05-0203	ASSY TAIL PLY S3000	1
20	13-08-0109	ASSY S3000 CNVR INLT HOPP	1
21	280-2-0026D	SKIRTING ASSY LH	1
22	280-2-0027D	SKIRTING ASSY RH	1



“S” SERIES BELT CONVEYOR

**S3000 CONVEYOR 2020**

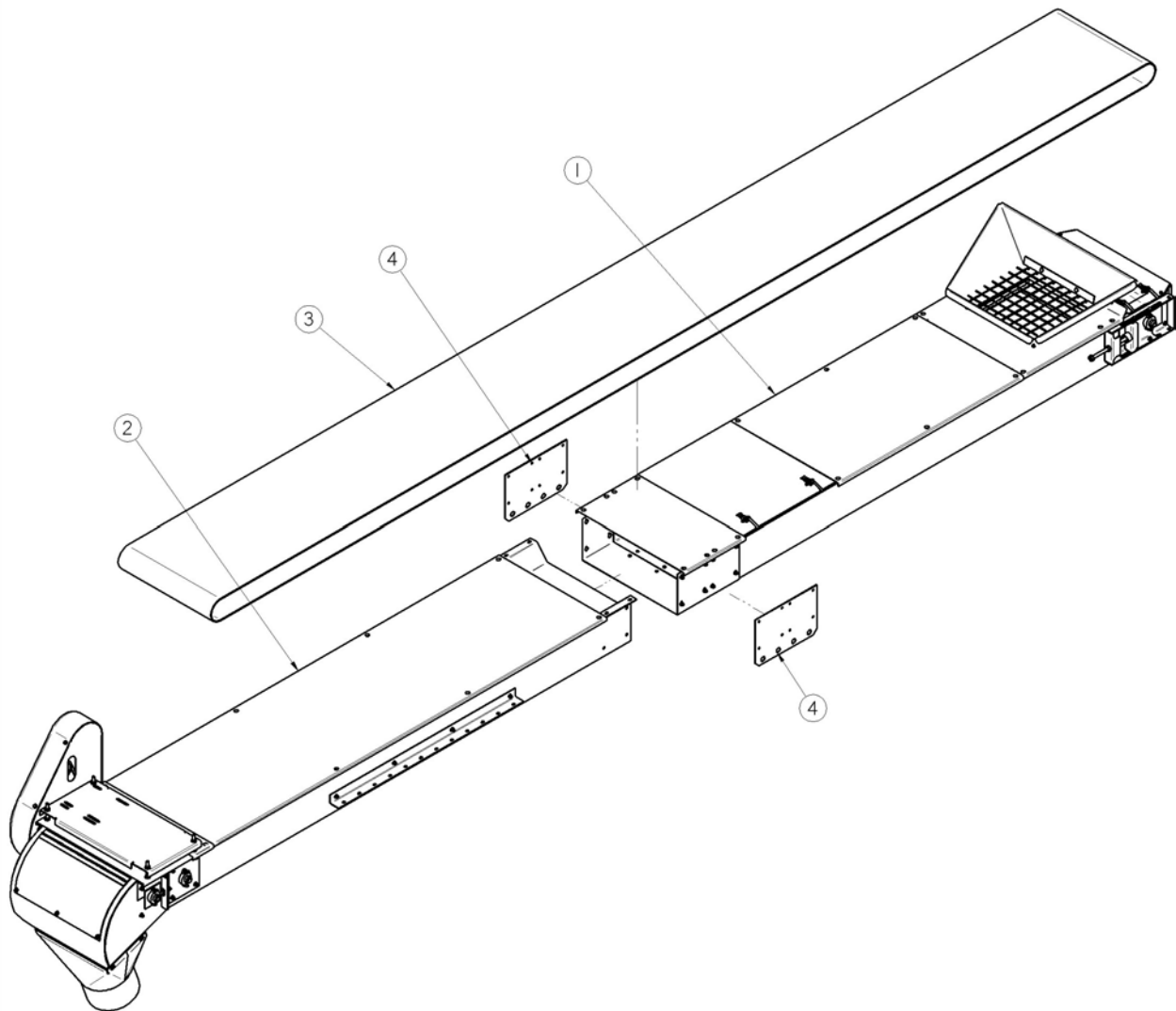

<u>Item #</u>	<u>Part #</u>	<u>Rev</u>	<u>Title</u>	<u>Qty</u>
1	05-07-0315	A	ASSY CNVR 24IN TAIL SECT	1
2	05-07-0316	A	ASSY CNVR 24IN HEAD SECT	1
3	11-02-0077	A	BELT CNVR CLTS 2024	1
4	280-3-0081	A	TRANSPORT MOUNT PLATE	2

“S” SERIES BELT CONVEYOR

**S3000 CONVEYOR 2520**

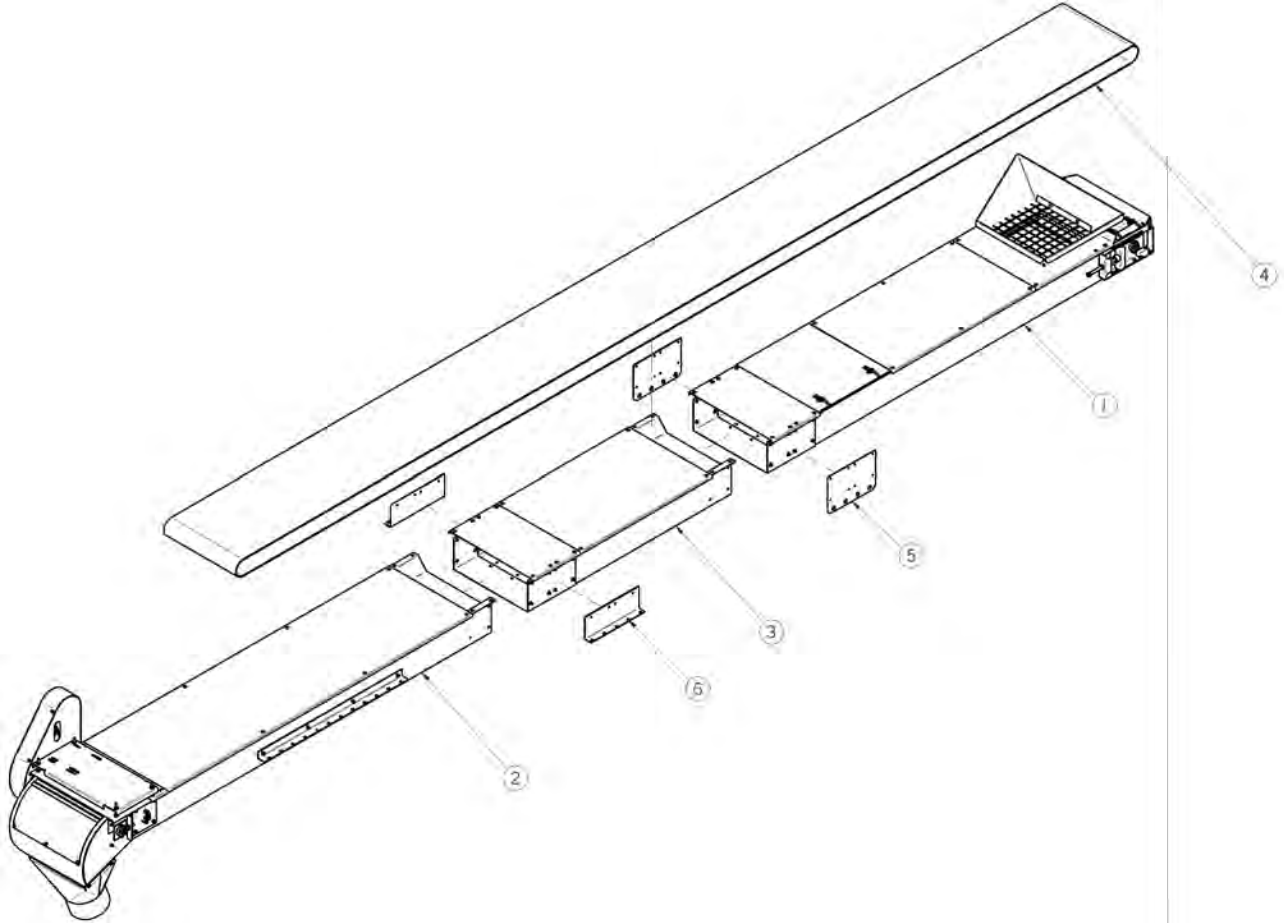

Item #	Part #	Rev	Title	Qty
1	05-07-0315	A	ASSY CNVR 24IN TAIL SECT	1
2	05-07-0316	A	ASSY CNVR 24IN HEAD SECT	1
3	05-07-0320	A	ASSY CNVR 24IN 5FT MID SECT	1
4	11-02-0074	A	BELT CNVR CLTS 2524	1
5	280-3-0081	A	TRANSPORT MOUNT PLATE	2
6	280-3-0090	A	SAFETY BRACKET STOP MOUNT	2

“S” SERIES BELT CONVEYOR

**S3000 CONVEYOR 3020**

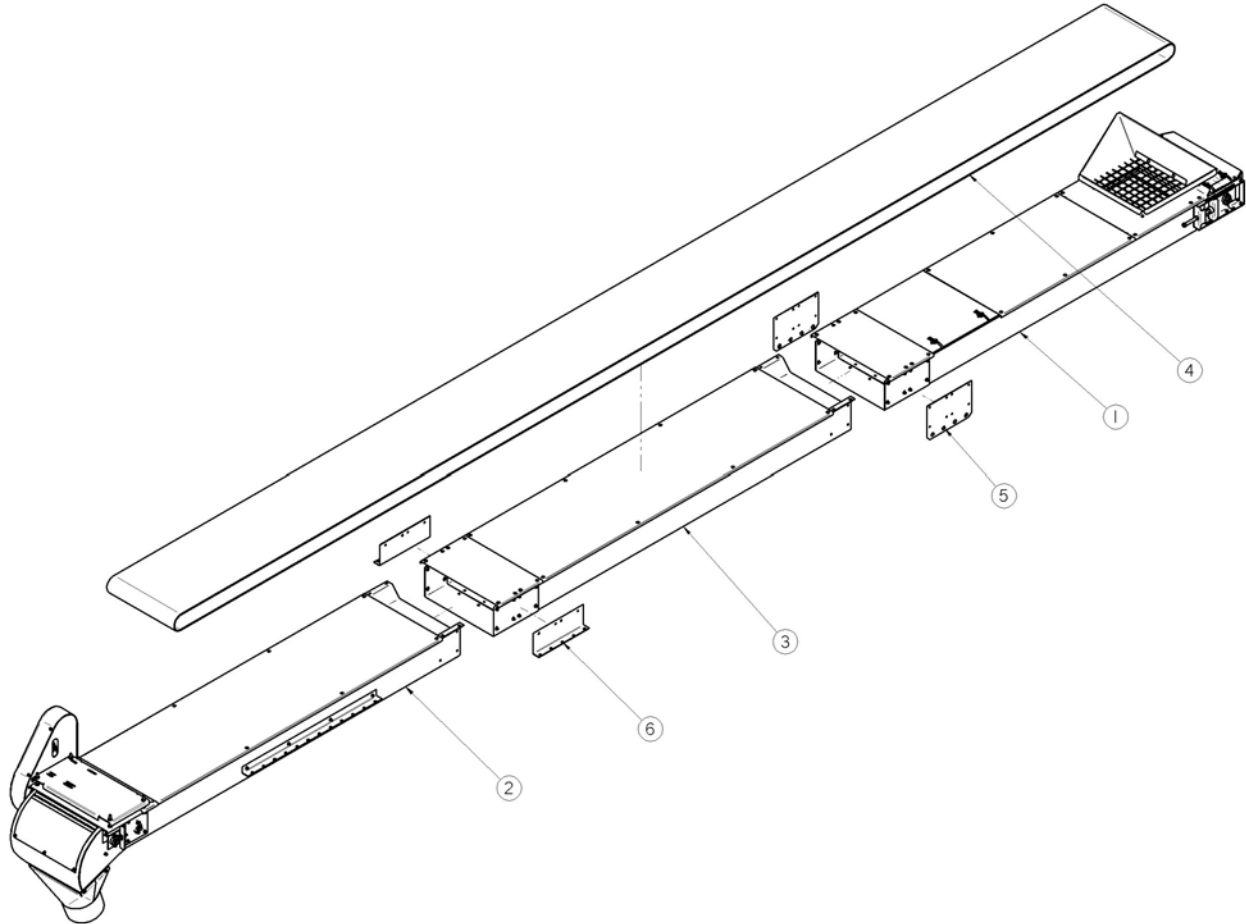

<u>Item #</u>	<u>Part #</u>	<u>Rev</u>	<u>Title</u>	<u>Qty</u>
1	05-07-0315	A	ASSY CNVR 24IN TAIL SECT	1
2	05-07-0316	A	ASSY CNVR 24IN HEAD SECT	1
3	05-07-0319	A	ASSY CNVR 24IN 10FT MID SECT	1
4	11-02-0039	A	BELT CNVR CLTS 3024	1
5	280-3-0081	A	TRANSPORT MOUNT PLATE	2
6	280-3-0090	A	SAFETY BRACKET STOP MOUNT	2

"S" SERIES BELT CONVEYOR

**S3000 CONVEYOR 3520**

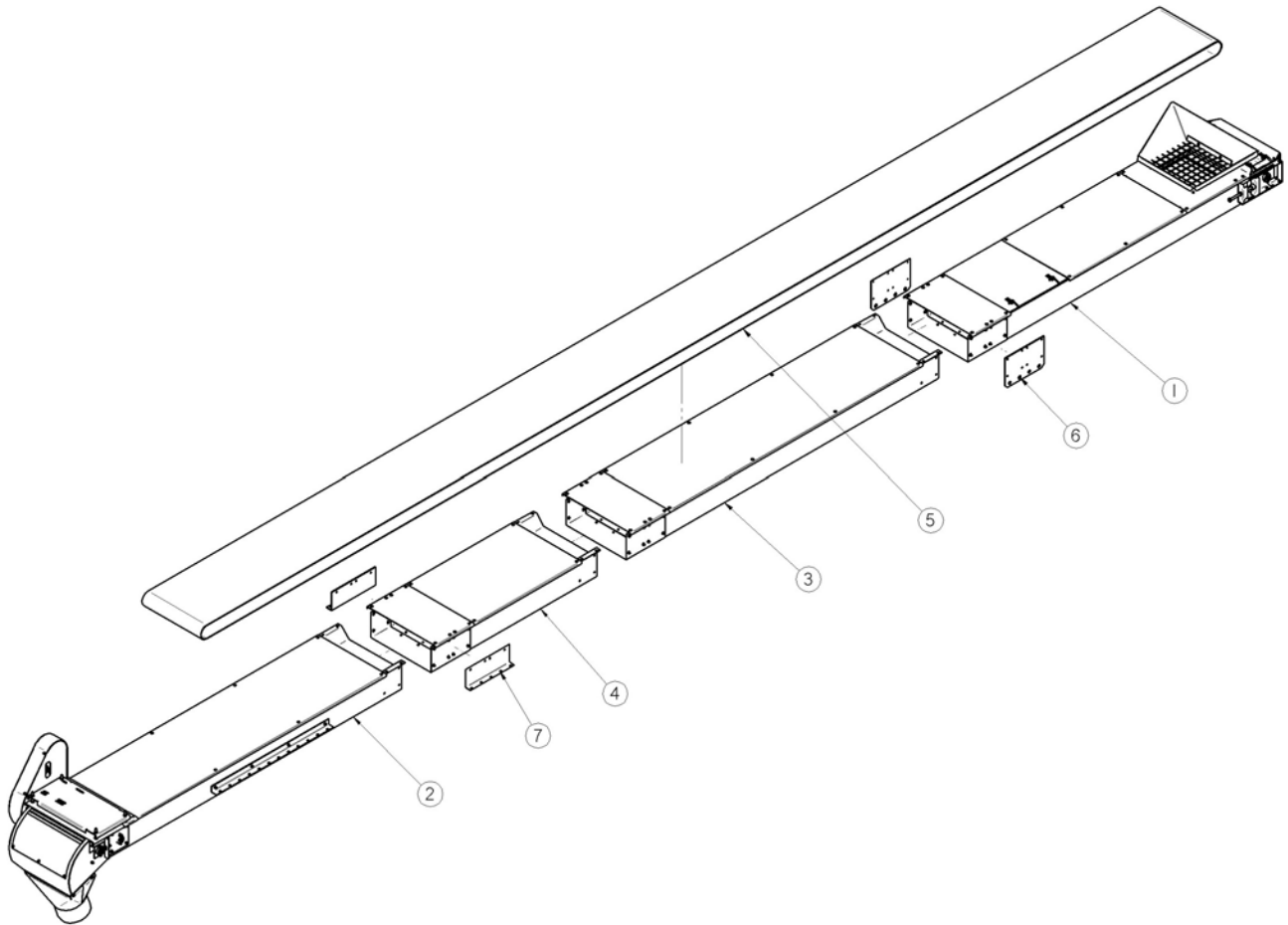

<u>Item #</u>	<u>Part #</u>	<u>Rev</u>	<u>Title</u>	<u>Qty</u>
1	05-07-0315	A	ASSY CNVR 24IN TAIL SECT	1
2	05-07-0316	A	ASSY CNVR 24IN HEAD SECT	1
3	05-07-0319	A	ASSY CNVR 24IN 10FT MID SECT	1
4	05-07-0320	A	ASSY CNVR 24IN 5FT MID SECT	1
5	11-02-0038	A	BELT CNVR CLTS 3524	1
6	280-3-0081	A	TRANSPORT MOUNT PLATE	2
7	280-3-0090	A	SAFETY BRACKET STOP MOUNT	2

"S" SERIES BELT CONVEYOR

**S3000 CONVEYOR 4020**

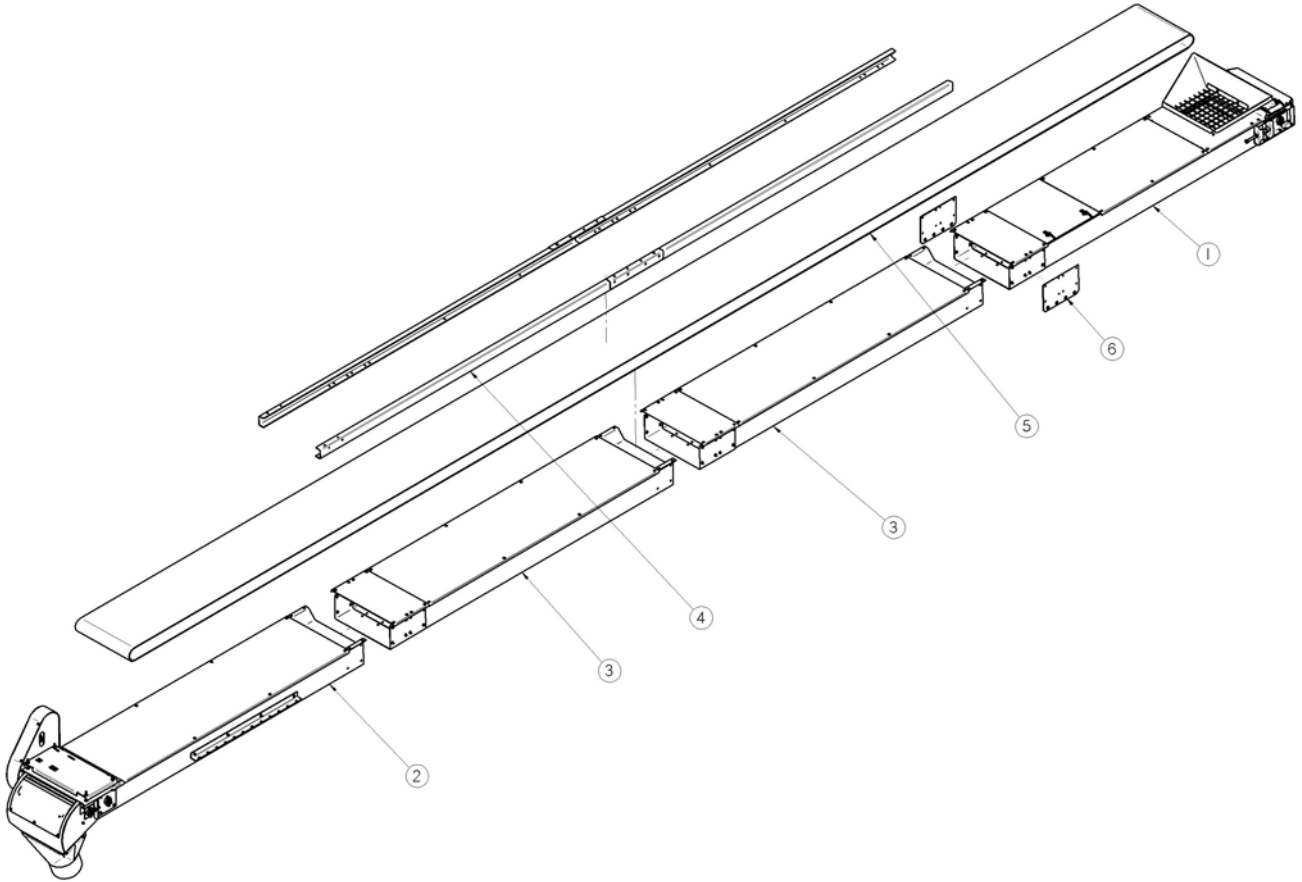

<u>Item #</u>	<u>Part #</u>	<u>Rev</u>	<u>Title</u>	<u>Qty</u>
1	05-07-0315	A	ASSY CNVR 24IN TAIL SECT	1
2	05-07-0316	A	ASSY CNVR 24IN HEAD SECT	1
3	05-07-0319	A	ASSY CNVR 24IN 10FT MID SECT	2
4	05-08-0093	A	KIT STRONGBACK 40 FT CNVR	1
5	11-02-0075	A	BELT CNVR CLTS 4024	1
6	280-3-0081	A	TRANSPORT MOUNT PLATE	2

“S” SERIES BELT CONVEYOR

**S3000 CONVEYOR 4520**

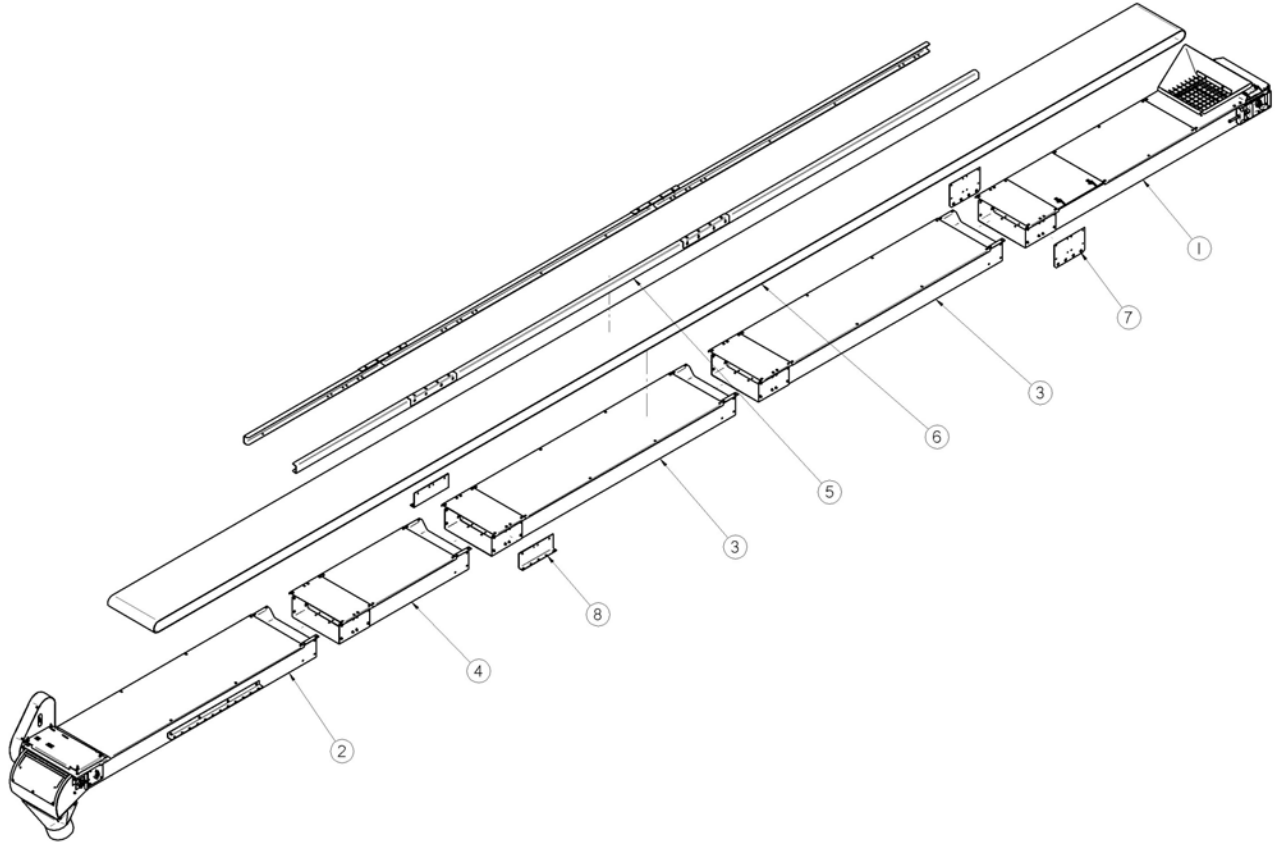

<u>Item #</u>	<u>Part #</u>	<u>Rev</u>	<u>Title</u>	<u>Qty</u>
1	05-07-0315	A	ASSY CNVR 24IN TAIL SECT	1
2	05-07-0316	A	ASSY CNVR 24IN HEAD SECT	1
3	05-07-0319	A	ASSY CNVR 24IN 10FT MID SECT	2
4	05-07-0320	A	ASSY CNVR 24IN 5FT MID SECT	1
5	05-08-0092	A	KIT STRONGBACK 45 FT CNVR	1
6	11-02-0076	A	BELT CNVR CLTS 4524	1
7	280-3-0081	A	TRANSPORT MOUNT PLATE	2
8	280-3-0090	A	SAFETY BRACKET STOP MOUNT	2

"S" SERIES BELT CONVEYOR

**S3000 FIXED CONVEYOR STAND**

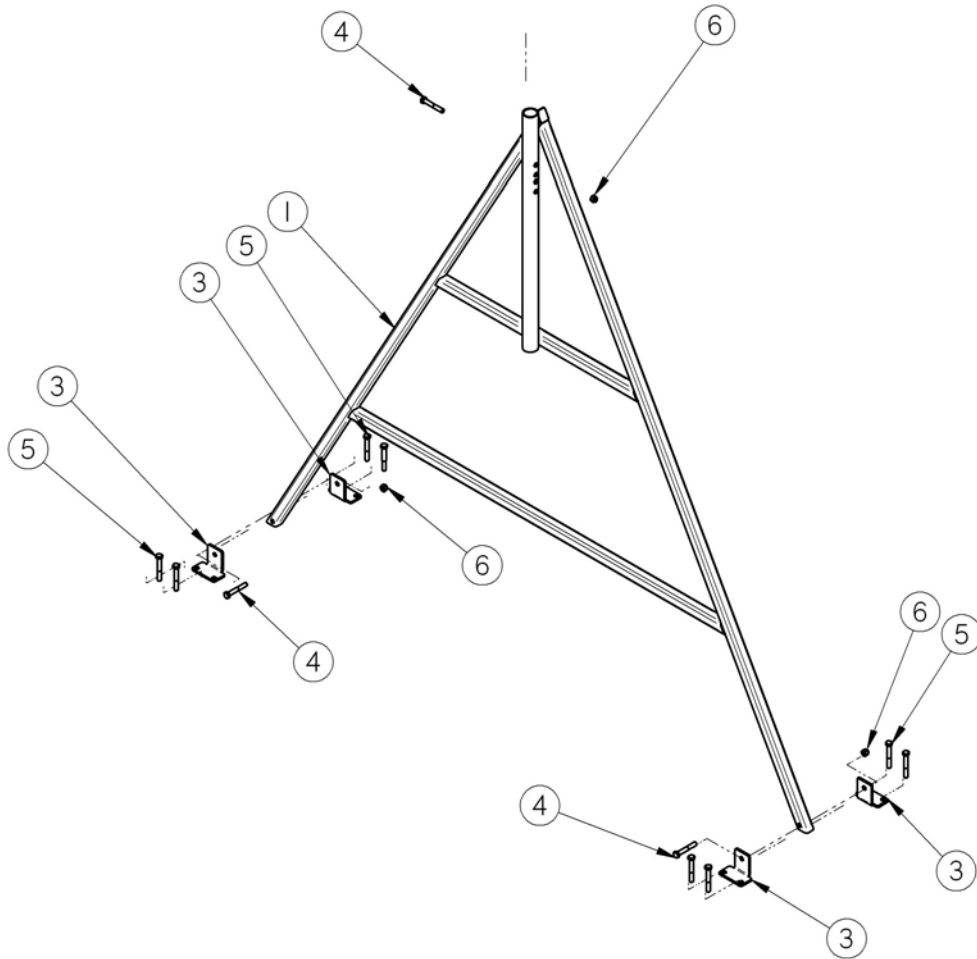
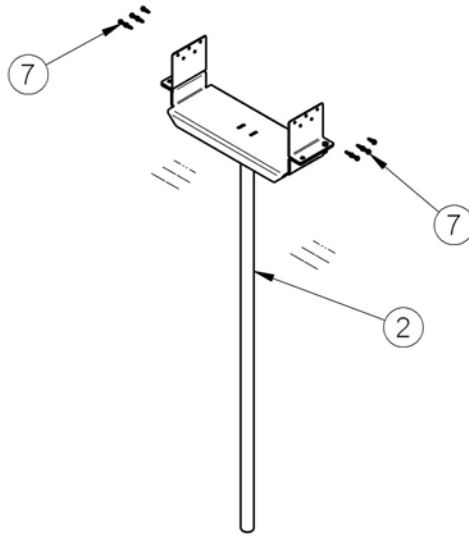

"S" SERIES BELT CONVEYOR

**S3000 FIXED CONVEYOR STAND PARTS LIST**

		S3000 STAND HEIGHT (inches)		68 TO 98	96 TO 132
		PART #		05-05-0061	05-05-0064
<u>Item #</u>	<u>Title</u>	<u>Part #</u>	<u>Qty</u>	<u>Part #</u>	<u>Qty</u>
1	CNVR STAND BASE	05-03-0640	1	05-03-0620	1
2	S2000 STAND TOP ADJ	05-05-0062	1	05-05-0062	1
3	PLT PIVOT CNVR STAND	05-10-3256	4	05-10-3256	4
4	BOLT .500-13 X 3.25 ZP GR5	06-01-0029	3	06-01-0029	3
5	BOLT .500-13 CONC ANCHOR ZP 4.25	06-01-0086	8	06-01-0086	8
6	NUT NYL LOCK .500-13 ZP GR5	06-03-0004	3	06-03-0004	3
7	SCRW SDST .250-14 X 1.000 HH ZP	06-06-0037	10	06-06-0037	10

		S3000 STAND HEIGHT (inches)		132 TO 208	200 TO 296
		PART #		05-05-0059	05-05-0065
<u>Item #</u>	<u>Title</u>	<u>Part #</u>	<u>Qty</u>	<u>Part #</u>	<u>Qty</u>
1	CNVR STAND BASE	05-03-0660	1	05-03-0646	1
2	S2000 STAND TOP ADJ	05-05-0060	1	05-05-0060	1
3	PLT PIVOT CNVR STAND	05-10-3256	4	05-10-3256	4
4	BOLT .500-13 X 3.25 ZP GR5	06-01-0029	3	06-01-0029	3
5	BOLT .500-13 CONC ANCHOR ZP 4.25	06-01-0086	8	06-01-0086	8
6	NUT NYL LOCK .500-13 ZP GR5	06-03-0004	3	06-03-0004	3
7	SCRW SDST .250-14 X 1.000 HH ZP	06-06-0037	10	06-06-0037	10



"S" SERIES BELT CONVEYOR

**S3000 FIXED CONVEYOR STAND (0-56 inches) & PARTS LIST**

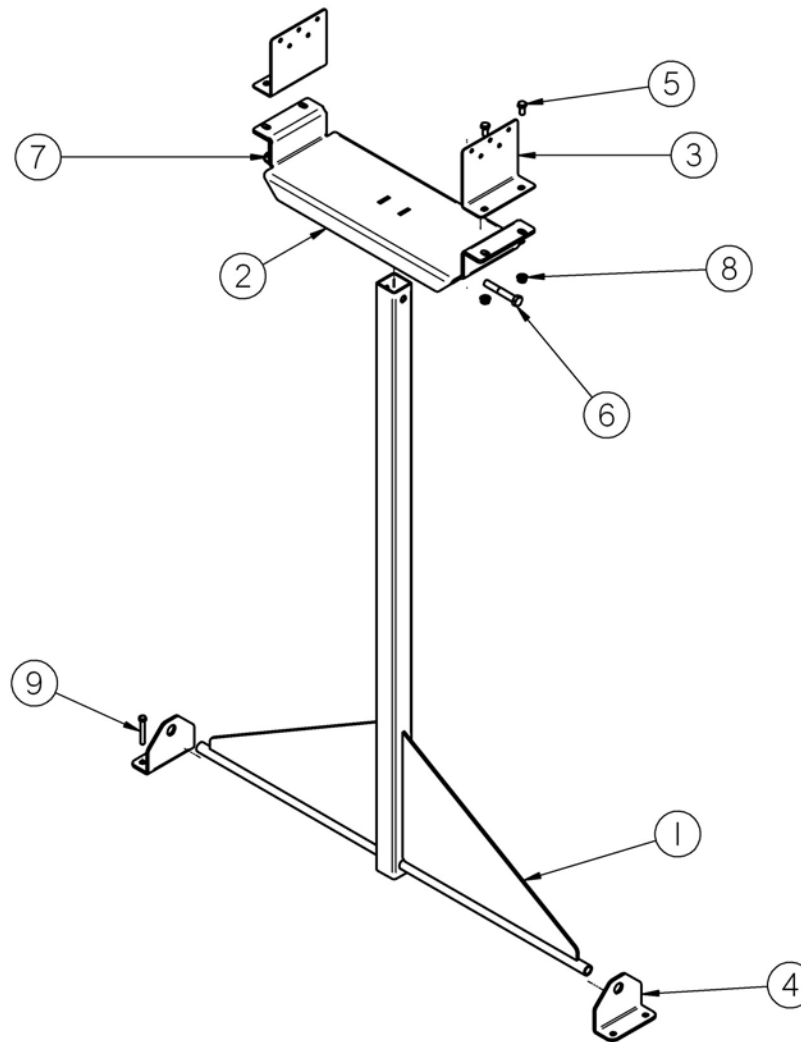

<u>Item #</u>	<u>Part #</u>	<u>Title</u>	<u>Qty</u>
1	05-03-0850	WDMT 15FT S2000 CART SUPP	1
2	05-03-0968	CNVR STAND TOP S3000	1
3	05-10-3052	PLT CNVR SUPT TOP	2
4	05-10-3628	BRKT SUPP MNT CNVR TAIL TALL	2
5	06-01-0015	BOLT .375-16 X 0.75 ZP GR5	4
6	06-01-0029	BOLT .500-13 X 3.25 ZP GR5	1
7	06-03-0004	NUT NYL LOCK .500-13 ZP GR5	1
8	06-03-0014	NUT LOCK FLG .375-16 ZP GR5	4
9	13-10-0012	KIT INSTALL CNVR STAND 0 TO 56IN	1

**S3000 PORTABLE CONVEYOR - UNDERCARRIAGE**

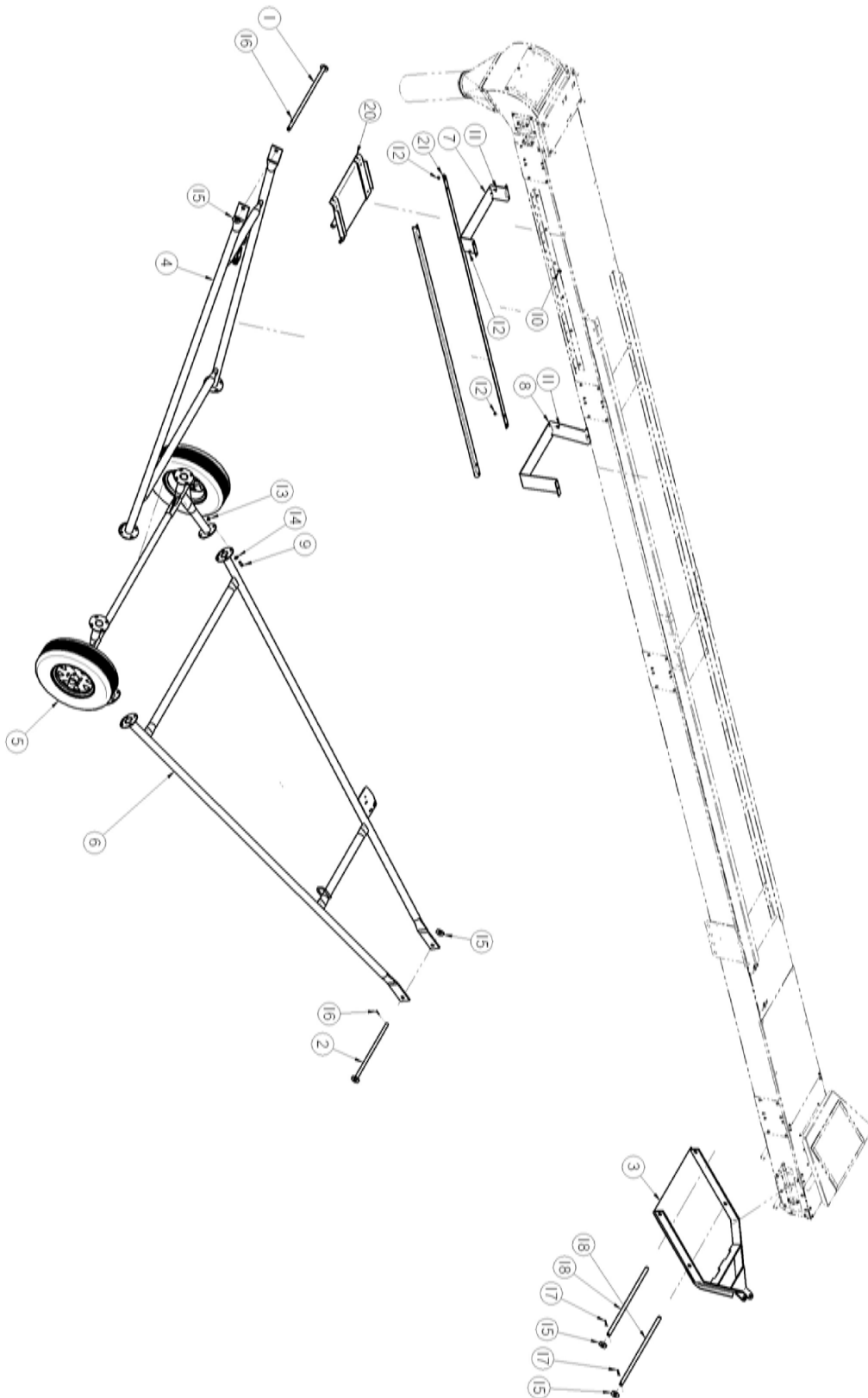

**S3000 PORTABLE CONVEYOR - UNDERCARRIAGE PARTS LIST**

Item #	Title	USC MODEL #		USC PART #	
		Part #	Qty	Part #	Qty
1	WDMT SLIDE PIN S3000	05-04-0108	1	05-04-0108	1
2	WDMT TRANSPORT MINT PIN S3000	05-04-0109	1	05-04-0109	1
3	WDMT HITCH 20BW HD	05-07-0423	1	05-07-0423	1
4	UPPER A-FR	05-07-0428	1	05-07-0429	1
5	ASSY AXLE SECT UNCG	05-08-0115	1	05-08-0115	1
6	LOWER A-FRAME	05-08-0117	1	05-08-0118	1
7	TRANSPORT SLIDE STOP 20BW	05-10-3880	2	05-10-3880	2
8	TRANSPORT REAR STOP BRACKET	NA		NA	
9	BOLT .500-13 X 1.25 ZP GR5	06-01-0080	16	06-01-0080	16
10	BOLT, FLG .375-16 UNC ZP GRADE 5; 3/4" LG	06-01-0124	8	06-01-0124	8
11	BOLT CRG .375-16X.750 ZP SHORT NECK	06-01-0153	8	06-01-0153	8
12	NUT LOCK FLG .375-16 ZP GR5	06-03-0014	16	06-03-0014	16
13	NUT LOCK FLG .500-13 ZP GR5	06-03-0015	16	06-03-0015	16
14	WSHR FLAT .500 ZP	06-05-0005	16	06-05-0005	16
15	WASHER, 1.00 FLAT ZP	06-05-0010	6	06-05-0010	6
16	.125 X 1.50 ZP COTTER PIN	06-09-0018	2	06-09-0018	2
17	.188 X 2.00 ZP COTTER PIN	06-09-0023	4	06-09-0023	4
18	HITCH PIN	10209A	2	10209A	2
19	ASSY TRANSPORT SLIDE 20BW	13-05-0212	1	13-05-0212	1
20	TRANSPORT SLIDE TRAP	280-3-0104	2	280-3-0089	2

**S3000 PORTABLE CONVEYOR - UNDERCARRIAGE PARTS LIST**

Item #	Title	Part #	Qty	Part #	Qty	Part #	Qty
		USC MODEL #	3520	4020	4520		
		USC PART #	05-08-0163	05-08-0164	05-08-0165		
1	WDMT SLIDE PIN S3000	05-04-0108	1	05-04-0108	1	05-04-0108	1
2	WDMT TRANSPORT MINT PIN S3000	05-04-0109	1	05-04-0109	1	05-04-0109	1
3	WDMT HITCH 20BW HD	05-07-0423	1	05-07-0423	1	05-07-0423	1
4	UPPER A-FR	05-07-0430	1	05-07-0431	1	05-07-0432	1
5	ASSY AXLE SECT UNCG	05-08-0115	1	05-08-0115	1	05-08-0115	1
6	LOWER A-FRAME	05-08-0120	1	05-08-0121	1	05-07-0407	1
7	TRANSPORT SLIDE STOP 20BW	05-10-3880	2	05-10-3880	1	05-10-3880	2
8	TRANSPORT REAR STOP BRACKET	NA		05-10-3937	1	NA	
9	BOLT .500-13 X 1.25 ZP GR5	06-01-0080	16	06-01-0080	16	06-01-0080	16
10	BOLT, FLG .375-16 UNC ZP GRADE 5; 3/4" LG	06-01-0124	8	06-01-0124	4	06-01-0124	8
11	BOLT CRG .375-16X.750 ZP SHORT NECK	06-01-0153	8	06-01-0153	8	06-01-0153	8
12	NUT LOCK FLG .375-16 ZP GR5	06-03-0014	16	06-03-0014	12	06-03-0014	16
13	NUT LOCK FLG .500-13 ZP GR5	06-03-0015	16	06-03-0015	16	06-03-0015	16
14	WSHR FLAT .500 ZP	06-05-0005	16	06-05-0005	16	06-05-0005	16
15	WASHER, 1.00 FLAT ZP	06-05-0010	6	06-05-0010	6	06-05-0010	6
16	.125 X 1.50 ZP COTTER PIN	06-09-0018	2	06-09-0018	2	06-09-0018	2
17	.188 X 2.00 ZP COTTER PIN	06-09-0023	4	06-09-0023	4	06-09-0023	4
18	HITCH PIN	10209A	2	10209A	2	10209A	2
19	ASSY TRANSPORT SLIDE 20BW	13-05-0212	1	13-05-0212	1	13-05-0212	1
20	TRANSPORT SLIDE TRAP	280-3-0089	2	280-3-0175	2	280-3-0190	2

**S SERIES CONVEYOR WINCH KIT**

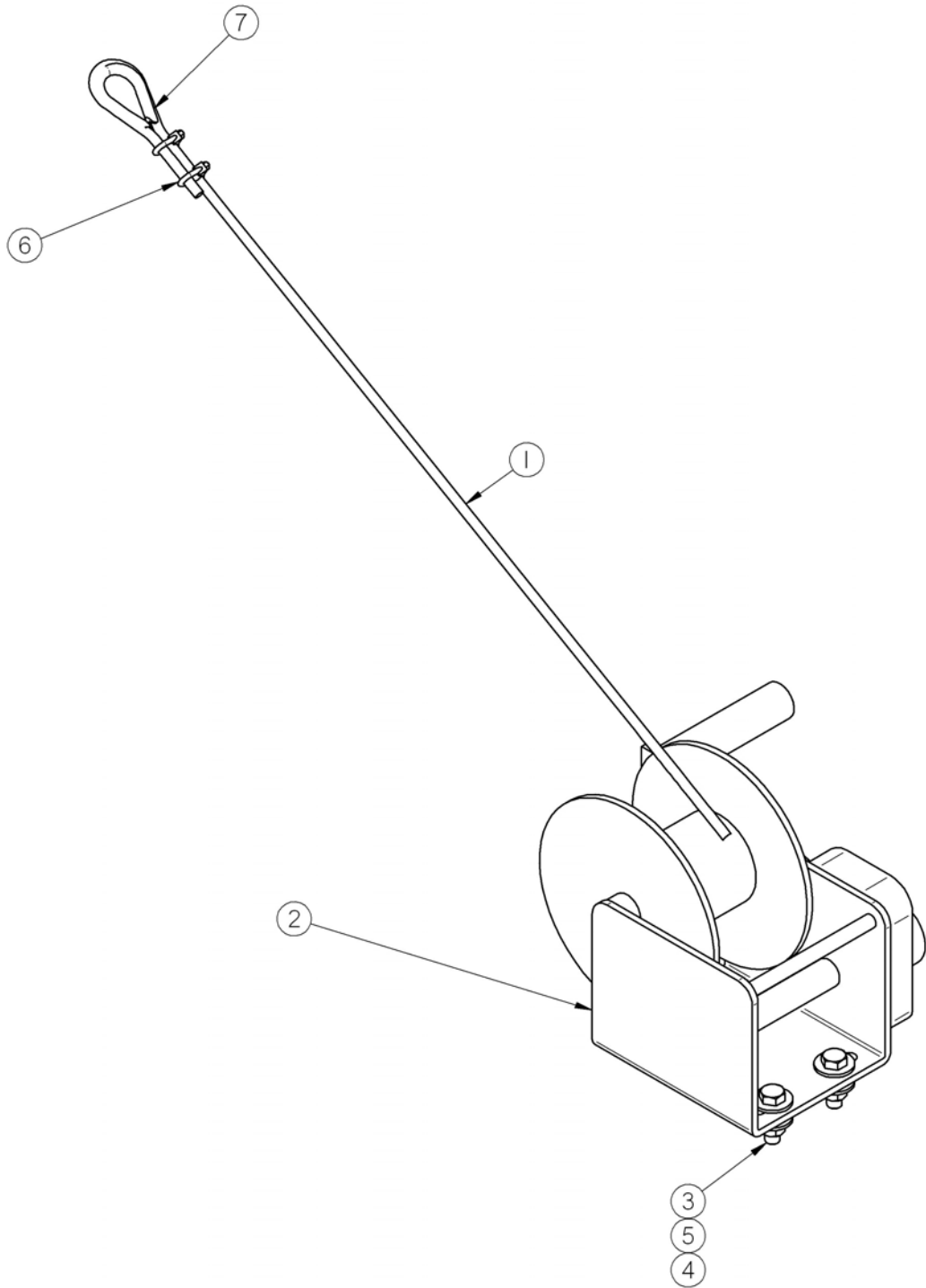

"S" SERIES BELT CONVEYOR

**S SERIES CONVEYOR WINCH KIT PARTS LIST**

		20FT WINCH KIT		25FT WINCH KIT	
		13-05-0099		13-05-0100	
<u>Item #</u>	<u>Title</u>	<u>Part #</u>	<u>Qty</u>	<u>Part #</u>	<u>Qty</u>
1	WIRE ROPE .250 DIA 7 X 19 CLASS STR	01-04-0031	15F T	01-04-0031	20F T
2	WINCH MNL 1500 LB W BRAKE	01-08-0017	1	01-08-0017	1
3	BOLT .375-16 X 1.25 ZP GR5	06-01-0053	3	06-01-0053	3
4	NUT FULL .375-16 ZP GR5	06-02-0003	3	06-02-0003	3
5	WSHR FLAT .375 ZP	06-05-0004	6	06-05-0004	6
6	CBL CLIP ROPE .250	06-07-0001	2	06-07-0001	2
7	THIMBLE .250 WIRE ROPE HD	06-07-0023	1	06-07-0023	1

		30FT WINCH KIT		35FT WINCH KIT	
		13-05-0101		13-05-0092	
<u>Item #</u>	<u>Title</u>	<u>Part #</u>	<u>Qty</u>	<u>Part #</u>	<u>Qty</u>
1	WIRE ROPE .250 DIA 7 X 19 CLASS STR	01-04-0031	28F T	01-04-0031	38F T
2	WINCH MNL 1500 LB W BRAKE	01-08-0017	1	01-08-0017	1
3	BOLT .375-16 X 1.25 ZP GR5	06-01-0053	3	06-01-0053	3
4	NUT FULL .375-16 ZP GR5	06-02-0003	3	06-02-0003	3
5	WSHR FLAT .375 ZP	06-05-0004	6	06-05-0004	6
6	CBL CLIP ROPE .250	06-07-0001	2	06-07-0001	2
7	THIMBLE .250 WIRE ROPE HD	06-07-0023	1	06-07-0023	1

		40FT WINCH KIT		45FT WINCH KIT	
		13-05-0102		13-05-0103	
<u>Item #</u>	<u>Title</u>	<u>Part #</u>	<u>Qty</u>	<u>Part #</u>	<u>Qty</u>
1	WIRE ROPE .250 DIA 7 X 19 CLASS STR	01-04-0031	45F T	01-04-0031	80F T
2	WINCH MNL 1500 LB W BRAKE	01-08-0017	1	01-08-0017	1
3	BOLT .375-16 X 1.25 ZP GR5	06-01-0053	3	06-01-0053	3
4	NUT FULL .375-16 ZP GR5	06-02-0003	3	06-02-0003	3
5	WSHR FLAT .375 ZP	06-05-0004	6	06-05-0004	6
6	CBL CLIP ROPE .250	06-07-0001	2	06-07-0001	2
7	THIMBLE .250 WIRE ROPE HD	06-07-0023	1	06-07-0023	1

**S SERIES CONVEYOR 5 HP MOTOR KIT**

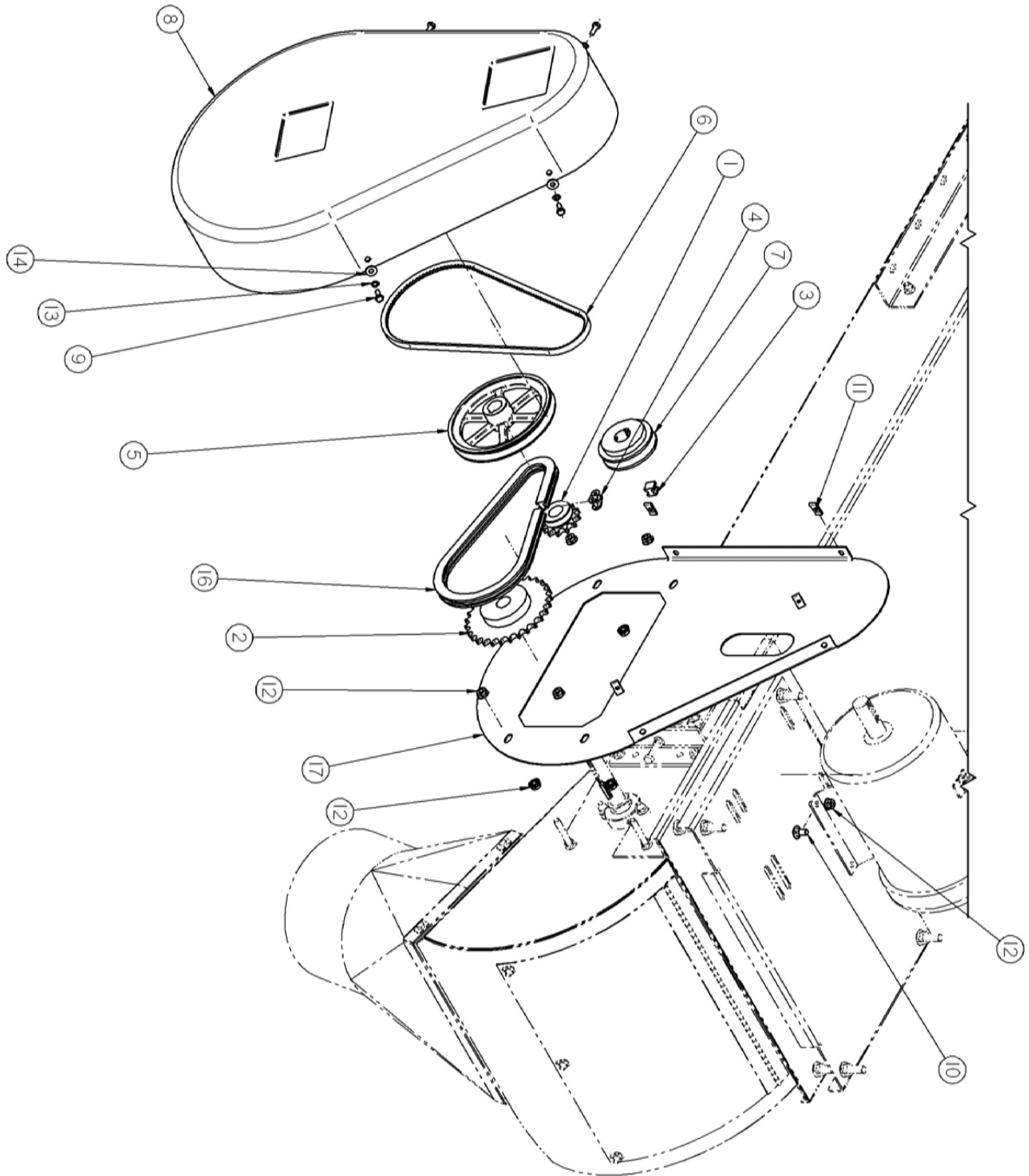

"S" SERIES BELT CONVEYOR

**S SERIES CONVEYOR 5 HP MOTOR KIT PARTS LIST**

<u>Item #</u>	<u>Part #</u>	<u>Rev</u>	<u>Title</u>	<u>Qty</u>
1	01-02-0076	A	Sprocket #50 12T 1.0000 in Bore Type B	1
2	01-02-0109	A	Sprocket #50 29T 1.00 in Bore Type B	1
3	01-04-0005	A	#50 CNTG LINK	1
4	01-04-0007	A	#50 OFFSET LINK	1
5	01-08-0058	A	SHEAVE BK75 1.00 BORE	1
6	01-08-0059	A	BELT BX38	1
7	01-08-0063	A	SHV BK36 1.125 FSH BORE	1
8	05-06-0035	A	DRIVE SHIELD MOLDED	1
9	06-01-0006	A	BOLT .250-20 X .750 ZP GR5	4
10	06-01-0153	A	BOLT CRG .375-16X.750 ZP SHORT NECK	4
11	06-02-0047	A	NUT .250-20 U-CLIP NUT	4
12	06-03-0014	A	NUT LOCK FLG .375-16 ZP GR5	12
13	06-04-0001	A	WSHR LOCK SPLT .250 ZP	4
14	06-05-0001	A	WASHER, FLAT .250	4
15	106-3-2036	A	KEY .250 X 1.25 CS	3
16	13-05-0185	A	50 ROLLER CHAIN 28.5IN	1
17	280-3-0053	A	SHIELD BACKPLATE	1



SECTION  
I

## LIMITED WARRANTY

USC, LLC, (Manufacturer) warrants its seed treating equipment as follows:

1. **Limited Warranty:** Manufacturer warrants that the Products sold hereunder will be free from defects in material and workmanship for a period of 12 months from date of shipment. If the Products do not conform to this Limited Warranty during the warranty period, Buyer shall notify Manufacturer in writing of the claimed defects and demonstrate to Manufacturer satisfaction that said defects are covered by this Limited Warranty. If the defects are properly reported to Manufacturer within the warranty period, and the defects are of such type and nature as to be covered by this warranty, Manufacturer shall, at its expense, furnish replacement Products or, at Manufacturer's option, replacement parts for the defective products. Shipping and installation of the replacement Products or replacement parts shall be at the Buyer's expense.

2. **Other Limits:** THE FOREGOING IS IN LIEU OF ALL OTHER WARRANTIES, EXPRESSED OR IMPLIED, INCLUDING BUT NOT LIMITED TO THE IMPLIED WARRANTIES OF MERCHANTABILITY AND FITNESS FOR A PARTICULAR PURPOSE. Manufacturer does not warrant against damages or defects arising from improper installation (where installation is by persons other than Manufacturer), against defects in products or components not manufactured by Manufacturer, or against damages resulting from such non-Manufacturer made products or components. Manufacturer passes on to the Buyer the warranty it received (if any) from the maker of such non-Manufacturer made products or components. This warranty also does not apply to Products upon which repairs and/or modifications have been effected or attempted by persons other than pursuant to written authorization by Manufacturer. Manufacturer does not warrant against casualties or damages resulting from misuse and/or abuse of product(s), acts of nature, effects of weather, including effects of weather due to outside storage, accidents, or damages incurred during transportation by common carrier.

3. **Exclusive Obligation:** THIS WARRANTY IS EXCLUSIVE. The sole and exclusive obligation of Manufacturer shall be to repair or replace the defective Products in the manner and for the period provided above. Manufacturer shall not have any other obligation with respect to the Products or any part thereof, whether based on contract, tort, strict liability or otherwise. Under no circumstances, whether based on this Limited Warranty or otherwise, shall Manufacturer be liable for incidental, special, or consequential damages.

4. **Other Statements:** Manufacturer's employees or representatives' oral or other written statements do not constitute warranties, shall not be relied upon by Buyer, and are not a part of the contract for sale or this limited warranty.

5. **Return Policy:** Approval is required prior to returning goods to USC, LLC. A restocking fee will apply.

6. **Entire Obligation:** This Limited Warranty states the entire obligation of Manufacturer with respect to the Products. If any part of this Limited Warranty is determined to be void or illegal, the remainder shall remain in full force and effect.



**USC, LLC**

2320 124th road

Sabetha, Ks 66534

PHONE: (785) 431-7900

FAX: (785) 431-7950

EMAIL: [sales-team@uscllc.com](mailto:sales-team@uscllc.com)

WEB: [www.uscllc.com](http://www.uscllc.com)

---