

Your Global Automation Partner

TURCK

Process Wiring Application Guide

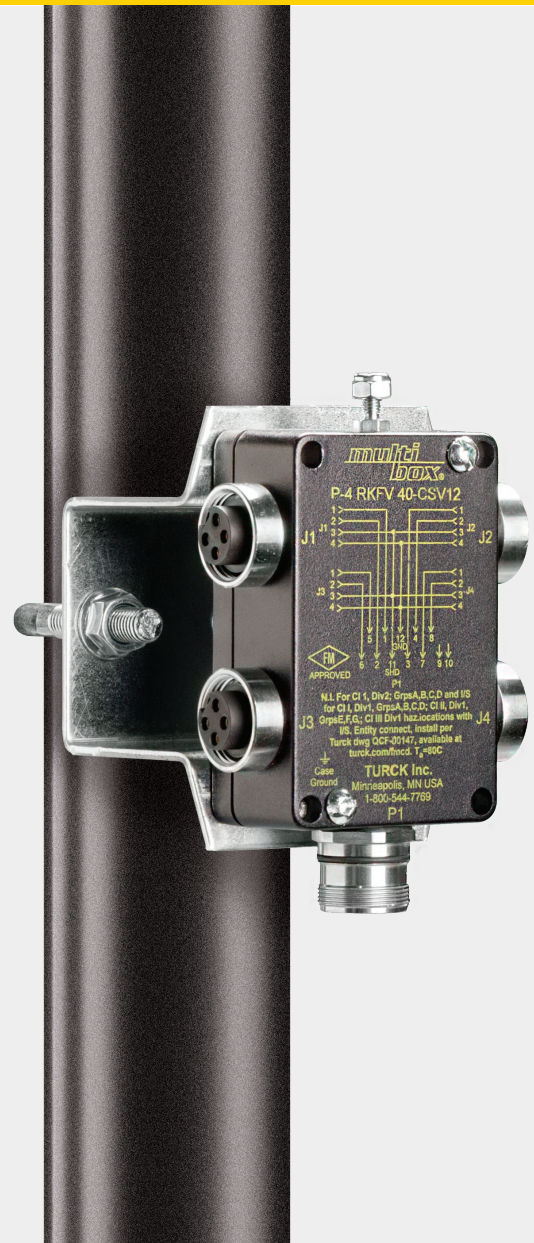

A Global Leader in Industrial Automation

Turck's sensors, connectivity, and fieldbus technology products are built to be the best. As one of the most **prominent** sensor manufacturers **in the world**, we even back our sensors with a **lifetime warranty**. Turck works by bringing **rugged engineering** solutions to your industrial automation applications.

85,000+
SOLUTIONS

50+
YEARS OF INNOVATION

2,000+
EXPERIENCED SALES REPRESENTATIVES

Pioneer in non-contact
sensing technology

Developed innovative **connectivity**
solutions in response to our customers' needs

Recognized the need for advanced **I/O solutions**
in harsh duty environments

**SUPPORT &
DEDICATED SERVICE**

EXTENSIVE WARRANTY

 **4,000+**
APPLICATION EXPERTS

RESPOND
and SOLVE over **1,200** inquiries
per day



Strategically placed manufacturing facilities in the

USA with **28** GLOBAL
SUBSIDIARIES

GLOBAL BUT LOCAL...

60 representations worldwide

Connectivity | Process Wiring

Questions that will be answered:

- What color of ITC cable do I specify?
- Which ITC cable do I specify and why?
- What parts go together as a system solution?

What is ITC cable?

Instrument tray cable.

Can you use ITC cable in Division 2?

In 1996, the NEC allowed ITC as a Division 2 wiring method.

NEC article 727 - Instrumentation tray cable: Type ITC

Wiring for instrumentation and control circuits operating at 150 volts or less and 5 amps or less.

For industrial establishments where a qualified person services the installation.

Permitted uses:

- In cable trays
- In raceways
- Armored cable
- ITC-ER rated cable with mechanical protection

Not permitted:

- Must not be run with power, lighting, Class I, or non-power-limited circuits.



Contents

How to Specify the Most Common Process Wiring Applications	5
Turck Offers Three Types of Rated ITC Cable	
What Color of ITC Cable Do I Specify?	
Which ITC Cable Do I Specify and Why?	
Exposed Run or ITC-ER is a Very High-Spec Cable	
Adding Quick-Disconnects	
Lokfast® Guards	
Multifast® is Available with Integral Locks	
All Connectors in Class I, Division 2 Require a Lokfast Guard or Locking Home Run Connector	
Available for all M12 Eurofast® and Minifast® Body Styles	
Cable Seals in Division 2	
Quick Disconnect Solution for Explosion-proof Devices in Division 2	13
Explosion Protection is Suitable for Division 1 or Division 2	
Explosion-proof Feed-Thru Application	
Cordset Solution Components	14
The Parts You Will Need: Class I Division 2 Hazardous Areas	
Receptacles	
Cordsets	
Recommended Receptacle Gender Placement	
Installation Instructions for Turck's 7/8-16 UN Minifast and M12 Eurofast Connectivity Products	
Process Wiring Physical Layer Guidelines	17
Process	
What Parts go Together as a System Solution?	19
4-Port Junction Box Options	
Typical Field Instrument Application: Non-Armored ITC-ER	
Typical Field Instrument Application: Armored ITC-ER (Armorfast)	
Instrument Wire to 4-Port Box Pinout	
Single Analog 4-Port Box	
Division 1 HART/Analog Intrinsic Safety	
4-Port Junction Box for Mixing Valve and Transmitter Applications	24
Process Wiring Matching Assembly Part Numbers	
Typical Field Instrument Application: ITC-ER	
4-Port Box with ITC-ER, Direct Burial (6-pin, 2 Analog/Port)	
V-Prox Valve Box Application	27
Inductive Proximity Sensors for Valve Position Indication	
V-Prox 4-Port Box with Grey ITC Drop and Black ITC-ER Direct Burial Colored Jacket	
8-Port Junction Box Options	28
Process Wiring Matching Assembly Part Numbers	
Typical Field Instrument Applications: ITC-ER	
Typical Field Instrument Applications: Armored ITC	
Instrument Wire to 8-Port Box Pinout	
Single Analog 8-Port Box ITC-ER	
Retrofit to Existing Division 2 Conduit Systems	32
Harsh Environment Applications	35
Harsh Environment Cable: Non-Armored and Braided Armor Construction	36
Harsh Environment: 4-Port Junction Box Options	37
4-Port Junction Box Options for Mixing Analog and Digital Signals	39
Harsh Environment Cable: 8-Port Junction Box Options	41
Retrofit to Existing Class I Division 2 Conduit System	43
AC Power Applications for Control Equipment	44
MC-HL Receptacle Extensions	47
Accessories	50

Connectivity | Process Wiring

How to Specify the Most Common Process Wiring Applications

Turck Offers Three Types of Rated ITC Cable: Basic ITC, ITC-ER & Armorfast®

ITC Cable is an NEC Division 2 Wiring Method

HAZARDOUS LOCATION
Class I, Division 2

NON-HAZARDOUS LOCATION

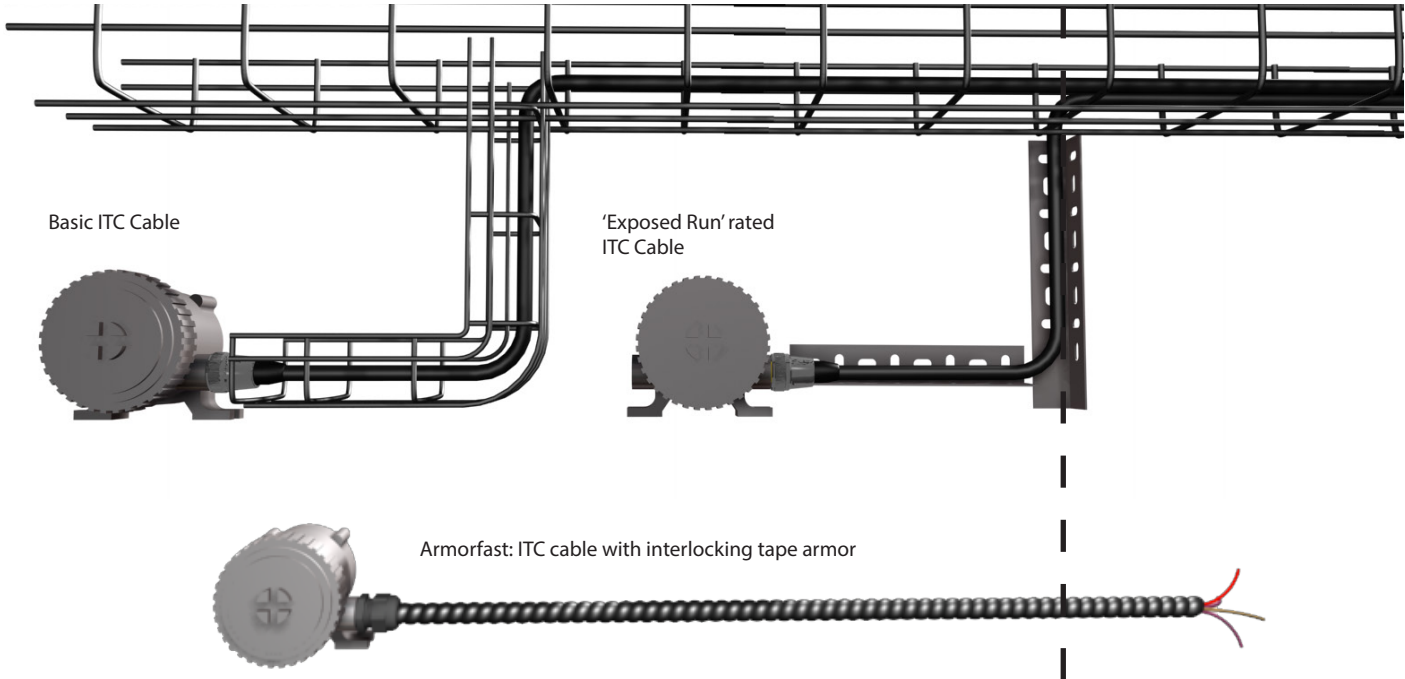

We reserve the right to make technical alterations without prior notice.

NEC 501.10(B)(1)(5):
"ITC cable as permitted in 727.4".

What Color of ITC Cable Do I Specify?

ITC cable comes in three colors:



Plum - original color

Black - preferred for direct sunlight applications

Blue - for intrinsically safe circuits

Connectivity | Process Wiring

How to Specify the Most Common Process Wiring Applications

Which ITC Cable Do I Specify and Why?

Basic ITC Cable

HAZARDOUS LOCATION
Class I, Division 2

NON-HAZARDOUS LOCATION

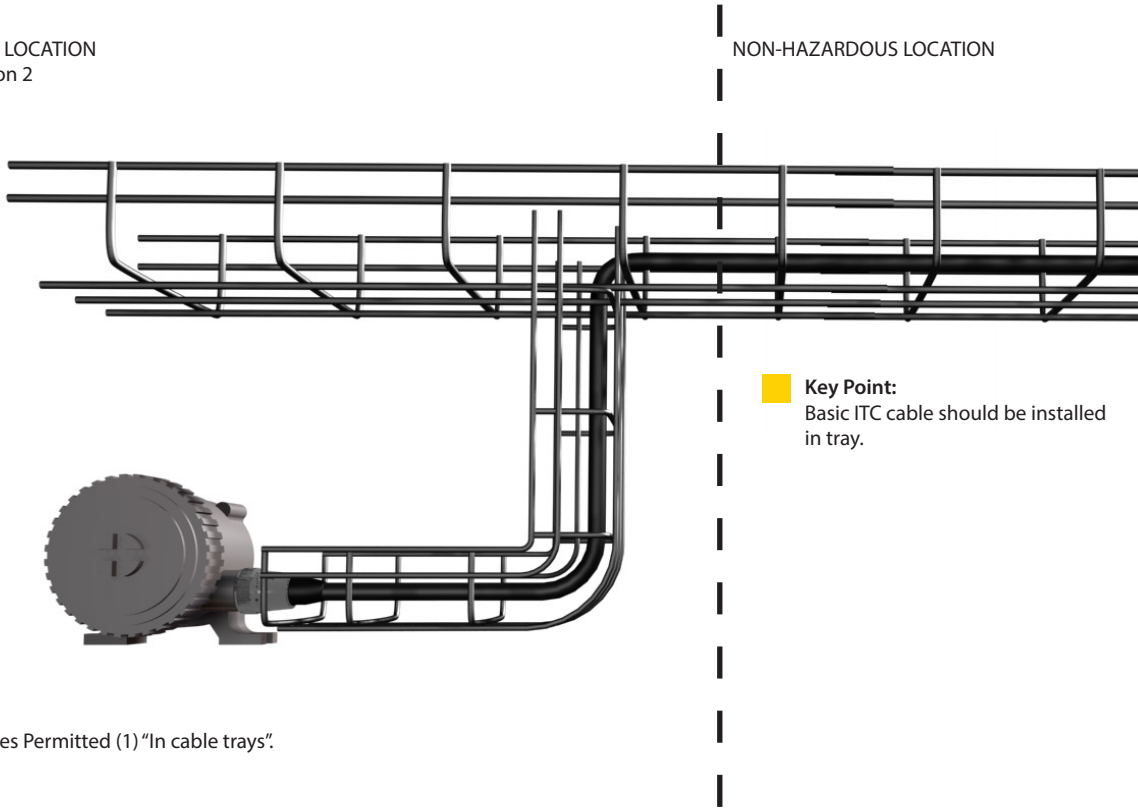

Key Point:
Basic ITC cable should be installed
in tray.

NEC 727.4 Uses Permitted (1) "In cable trays".

We reserve the right to make technical alterations without prior notice.

Connectivity | Process Wiring

How to Specify the Most Common Process Wiring Applications

Which ITC Cable Do I Specify and Why?

ITC-ER Cable

HAZARDOUS LOCATION
Class I, Division 2

NON-HAZARDOUS LOCATION

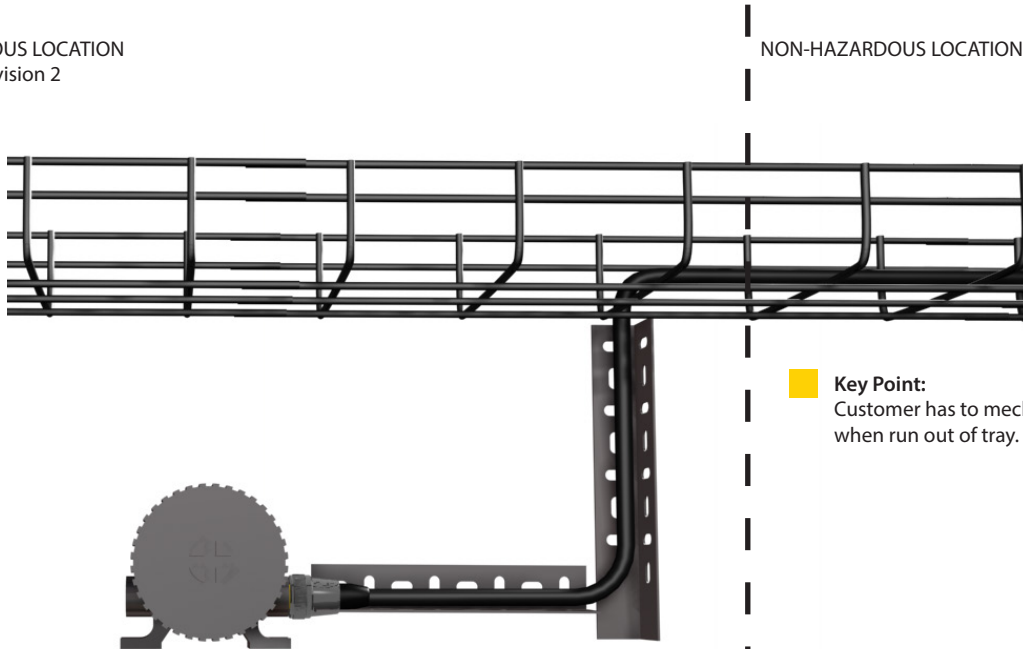

Key Point:
Customer has to mechanically protect ITC-ER cable when run out of tray.

NEC 727.4 Uses Permitted (5) "Cable without a metallic sheath or armor that complies with the crush and impact requirements of type MC cable and is identified for such use with the marking ITC-ER shall be permitted to be installed exposed."

We reserve the right to make technical alterations without prior notice.

Exposed Run or ITC-ER is a Very High-Spec Cable

Basic ITC is already a premium cable. The flammability and temperature requirements of UL 2250 dictate a rugged cable.

Crush and impact requirements for ER cable are extremely difficult for unarmored cable to meet.

- Crush – Cable is crushed 10 times between a flat plate and a 3/4 inch rod. The average force to produce an electrical short must exceed 1000 lbs.
- Impact – Cable is impacted 10 times by a 10 lb. ball dropped from 1 1/2 ft. at least eight impacts must produce no electrical shorts.

Formerly identified as 'OPEN WIRING'.



Connectivity | Process Wiring

How to Specify the Most Common Process Wiring Applications

Which ITC Cable Do I Specify and Why?

Armorfast ITC Cable

HAZARDOUS LOCATION
Class I, Division 2

NON-HAZARDOUS LOCATION

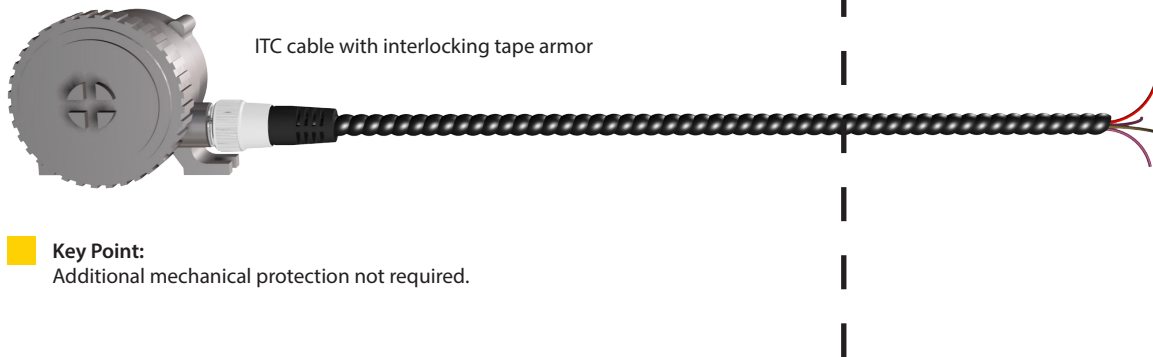

Key Point:

Additional mechanical protection not required.

NEC 727.4 Uses Permitted (4) "Enclosed in a smooth metallic sheath, continuous corrugated metallic sheath, or interlocking tape armor applied over the nonmetallic sheath in accordance with 727.6. The cable shall be supported and secured at intervals not exceeding 1.8 m (6 ft)."

We reserve the right to make technical alterations without prior notice.



Connectivity | Process Wiring

How to Specify the Most Common Process Wiring Applications

Adding Quick-Disconnects

HAZARDOUS LOCATION
Class I, Division 2

NON-HAZARDOUS LOCATION

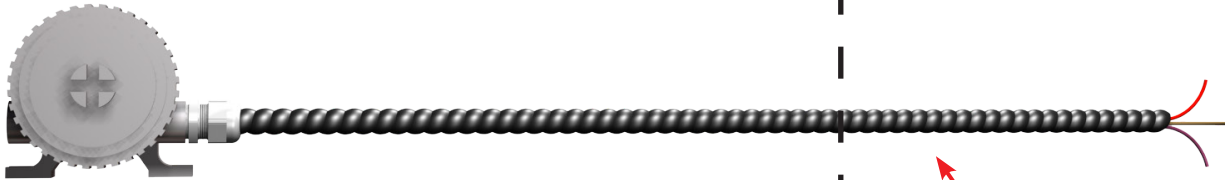

A Turck receptacle installed in an instrument certified for Class I, Division 2, coupled with a Turck cordset with ITC rated cable offers the benefits of quick-disconnect wiring in hazardous locations.

ITC rated cable

HAZARDOUS LOCATION
Class I, Division 2

NON-HAZARDOUS LOCATION

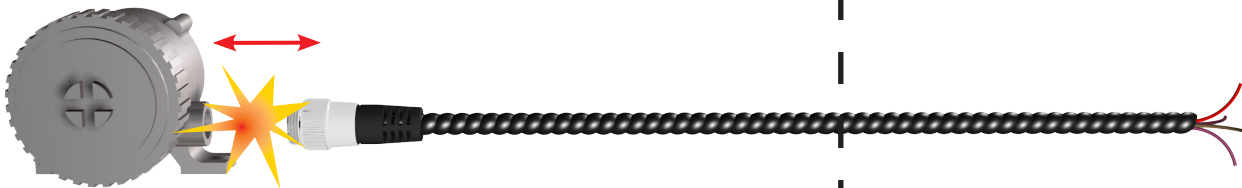

Connectors that do not require the use of a tool to disconnect are 'normally arcing', and therefore not allowed in ignition-capable circuits in hazardous locations.

HAZARDOUS LOCATION
Class I, Division 2

NON-HAZARDOUS LOCATION



The simple addition of a Lokfast guard solves this problem!
Note: All connectors in Class I, Division 2, require a Lokfast guard.

We reserve the right to make technical alterations without prior notice.

Connectivity | Process Wiring

How to Specify the Most Common Process Wiring Applications

Lokfast Guards

Lokfast guards render a quick-disconnect connection not 'normally arcing' by:

- Making disconnection impossible while in place by eliminating access to coupling nut
- Warning the user to disconnect power before removing
- Requiring a tool for removal

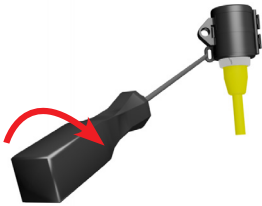

Multifast is Available with Integral Locks

P-C.ML ..

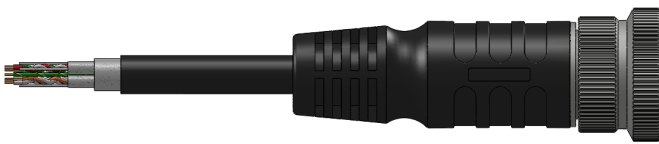

P-C.MT ..

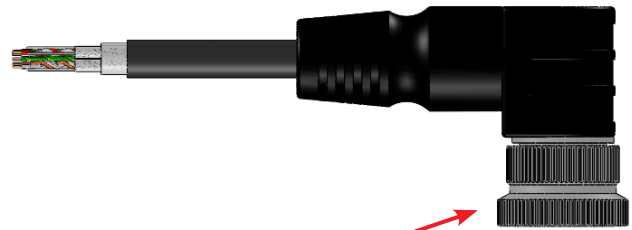

■ Multifast cords have optional locking set-screws for use in Division 2

■ For Class I, Division 2 hazardous areas you MUST use M23 Multifast with locking set-screw

We reserve the right to make technical alterations without prior notice.

Connectivity | Process Wiring

How to Specify the Most Common Process Wiring Applications

All Connectors in Class I, Division 2 Require a Lokfast Guard or Locking Home Run Connector

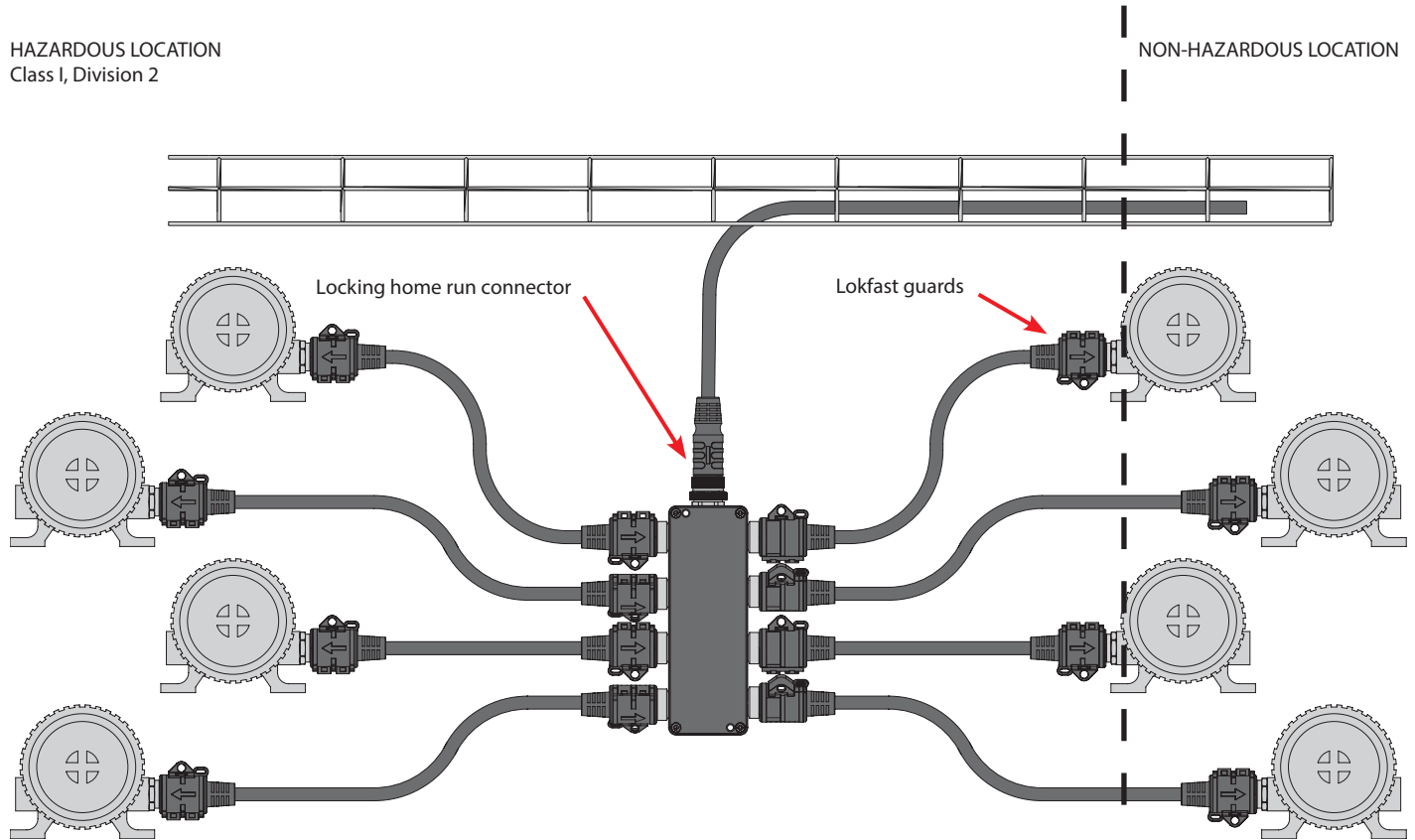

We reserve the right to make technical alterations without prior notice.

Available for all M12 Eurofast and Minifast Body Styles



Lock-Mini
Lock-Mini-B&C



Lock-Mini-FW



Lock-Euro-A



Lock-Euro-G
Lock-Euro-FW

Connectivity | Process Wiring

How to Specify the Most Common Process Wiring Applications

Cable Seals in Division 2

HAZARDOUS LOCATION
Class I, Division 2

NON-HAZARDOUS LOCATION

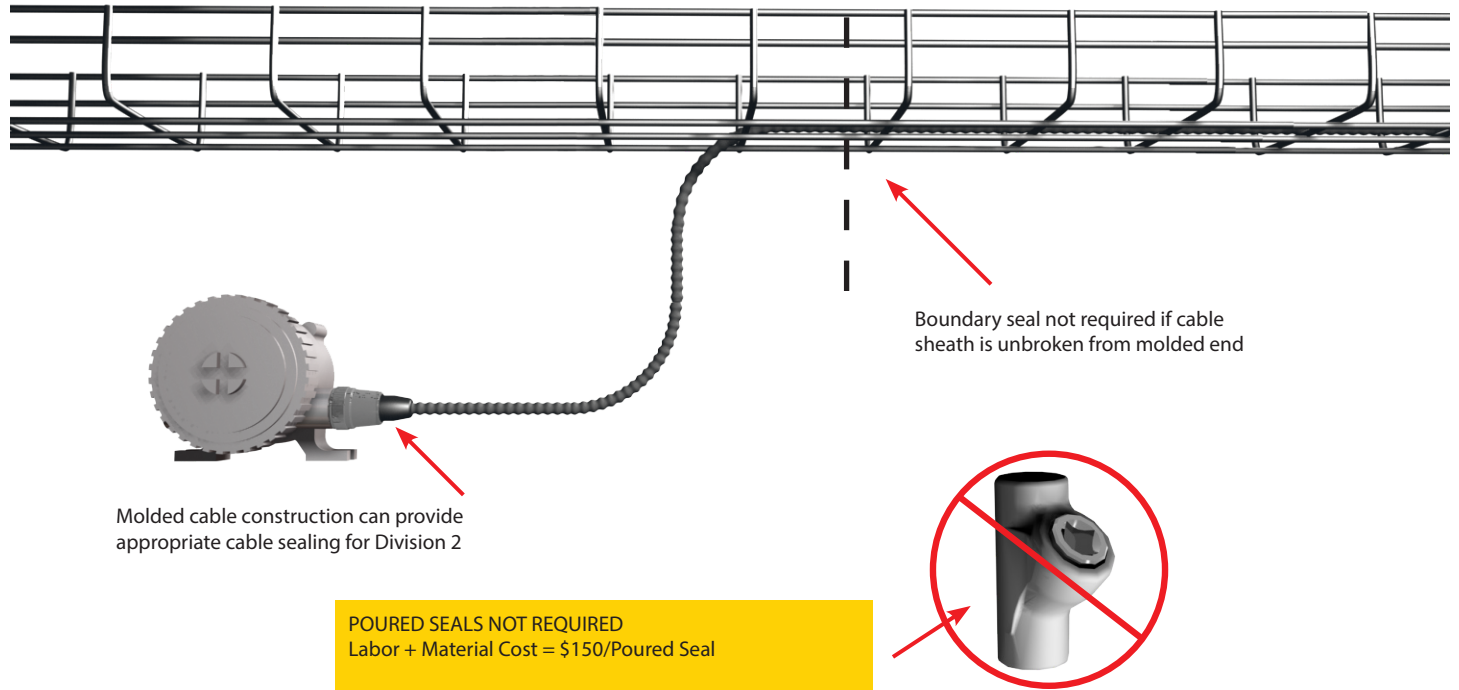

We reserve the right to make technical alterations without prior notice.

Connectivity | Process Wiring

Quick Disconnect Solution for Explosion-proof Devices in Division 2

Explosion Protection is Suitable for Division 1 or Division 2

HAZARDOUS LOCATION
Class I, Division 2

NON-HAZARDOUS LOCATION



For installation of explosion-proof rated field device with 1/2-14 NPT entry threads in Class I, Division 2:

- Install 7/8-16 UN Minifast receptacle, e.g. P-RSFV 40EX-*14.5/NPT
- Connect with Minifast cordset and Lokfast® guard
- Install cable per ITC rules for Class I, Division 2

Note: These are not explosion-proof connectors. They are an explosion-proof feed-thru that provide an explosion-proof penetration into an explosion-proof enclosure. The external pin/socket interface is not explosion-proof.

We reserve the right to make technical alterations without prior notice.

Explosion-proof Feed-Thru Applications

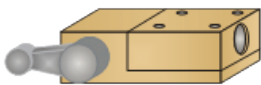

EXP limit switches.



EXP pressure switches, temperature switches, etc. EXP instruments without NI approval.

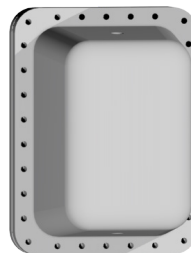

Bringing intrinsically safe or nonincendive circuits out of EXP enclosures.

Connectivity | Process Wiring

Cordset Solution Components

The Parts You Will Need: Class I, Division 2 Hazardous Areas



Male receptacle for field instrument



Female receptacle for customer supplied junction box or integral to Turck junction box



2 pcs of Lokfast one for each connector



Extension cordset

Receptacles

Male receptacle visual cues:

- Male pins are visible from front view of receptacle
- Mating threads are on outside of receptacle housing
- Male threads mount to field instrument



Female receptacle visual cues:

- No pins visible from front view of receptacle
- Mating threads are on inside of receptacle housing
- Male threads mount to junction boxes

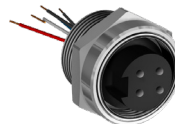

Connectivity | Process Wiring

Cordset Solution Components

Cordsets

Cordset extension visual cues:

- Cable has connectors on both ends
- Male connector on one end
- Female connector on other end

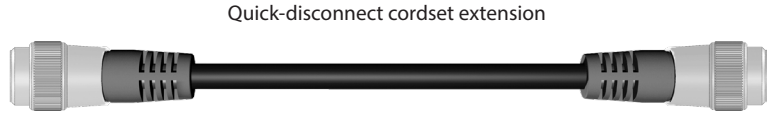

Single ended cord visual cues:

- Cable has single connector on one end
- Connector can be male or female to meet an application
- Flying lead terminates into junction boxes with cable gland approved for hazardous area classification



Recommended Receptacle Gender Placement



Use male receptacle at instrument

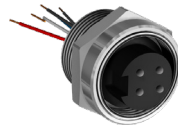

Use female receptacle at junction box

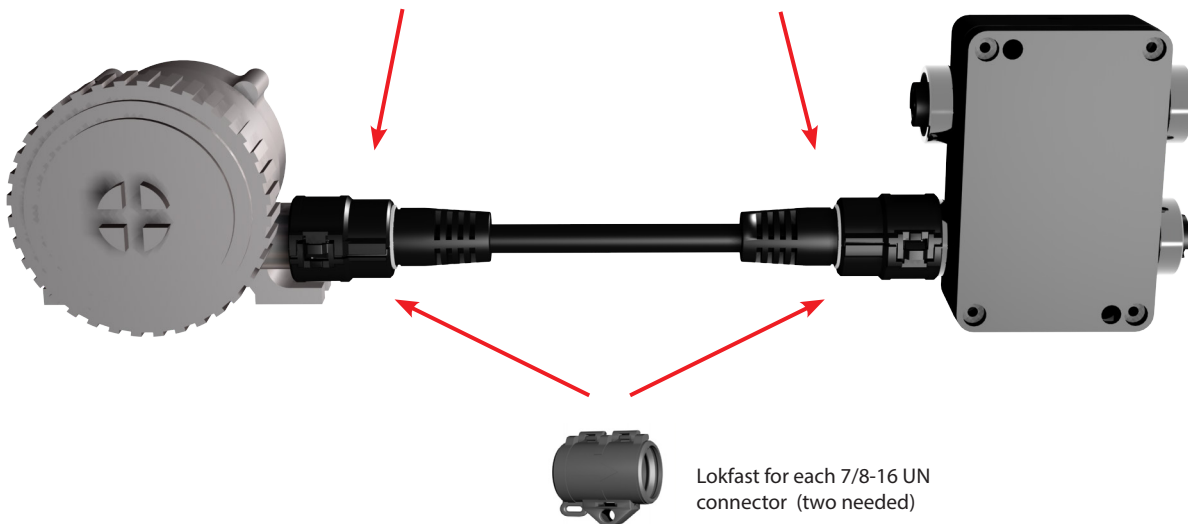

We reserve the right to make technical alterations without prior notice.

Connectivity | Process Wiring

Cordset Solution Components

Installation Instructions for Turck's 7/8-16 UN Minifast and M12 Eurofast Connectivity Products

Step One:

Many instruments are available with a Turck receptacle pre-installed. If a receptacle is already installed, proceed to Step Two. If field installation of a receptacle is necessary, feed the receptacle leads through the instrument's conduit entry and thread the receptacle into the entry threads. Receptacles with NPT threads should be tightened per the requirements for NPT conduit fittings. Receptacles with straight threads (M20 or NPSM) should be tightened to deflect the O-ring sufficiently to create a good seal. The receptacle leads should then be connected to the terminals of the instrument. Consult the instrument manual for terminal identification and preferred method of connection. Also, please refer to the product catalog or visit www.turck.us for the pin-out of the receptacle.



Step Two:

Minifast connectors are designed to industry standards SAE H1738 and ANSI/B93.55M. The environmental seal for mated connectors is formed by the 'cork and bottle' design of the pin and socket carriers in which each connection chamber is individually sealed. The connection must be properly secured to achieve this seal, as well as to ensure a good electrical performance.

The keyed cordset should be aligned with the key on the instrument receptacle. The cordset should then be pushed into the receptacle and the coupling nut turned until hand tight. The cordset should then be pushed firmly into the receptacle a second time and the coupling nut hand tightened again. This generally allows an additional 1/8 - 1/4 turn and ensures that a tight, weather-proof connection is made. No tools should be used in tightening the connections, as damage to the contacts could occur if the connection is over-tightened.

Eurofast connectors are designed to industry standard SAE H1738. The environmental seal for mated connectors is formed by an O-ring seal. The connection must be properly secured to achieve this seal, as well as to ensure a good electrical performance.

The keyed cordset should be aligned with the key on the instrument receptacle. The cordset should then be pushed into the receptacle and the coupling nut turned until hand tight. While rotating the coupling nut, the installer may notice a 'ratcheting' sensation. This is an anti-vibration feature designed to maintain the connection in high-vibration environments. No tools should be used in tightening the connection, as damage to the contacts could occur if the connection is over-tightened.

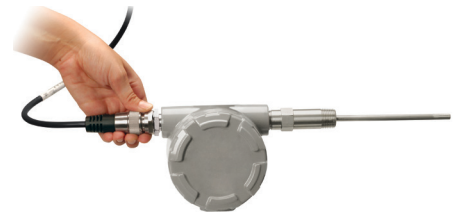

Step Three:

Most Turck process wiring products are designed and approved for use in hazardous locations. If the installation is in a hazardous location, there may be additional actions necessary, such as locking the connection with a Lokfast® guard (as shown in the figure below), using an approved energy limiting source of power, or ensuring that the instrument has the appropriate approval. FM approved control drawings detail the requirements for compliant installation of Turck products. The appropriate control drawing number will be identified in the product markings and may be viewed or downloaded from www.turck.us/fmcd. Consult the instrument manual to ensure the instrument has the appropriate approval and to determine if the approval imposes any additional constraints.

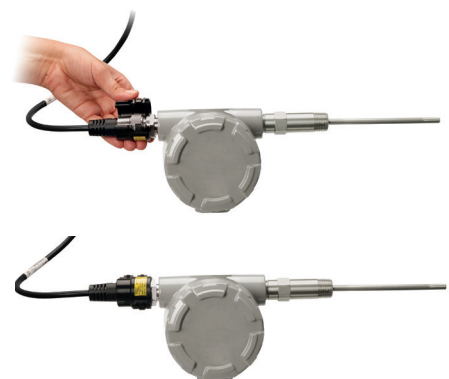

We reserve the right to make technical alterations without prior notice.

Connectivity | Process Wiring

Process Wiring Physical Layer Guidelines

Process

1. Define the scope of the project

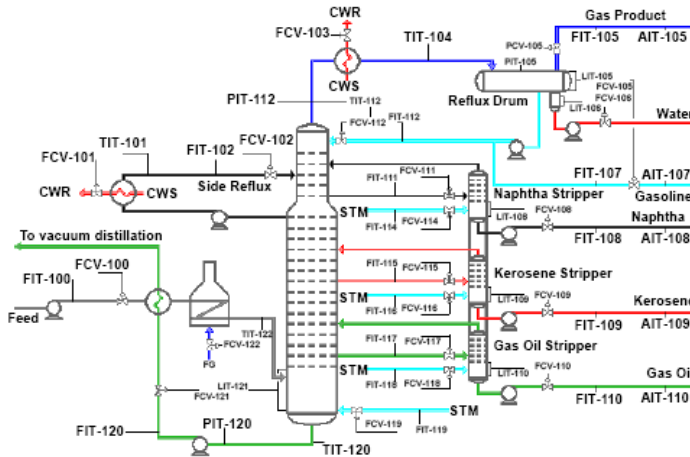

2. Locate and install instruments in the field



3. Install Turck process bricks near groups of instruments

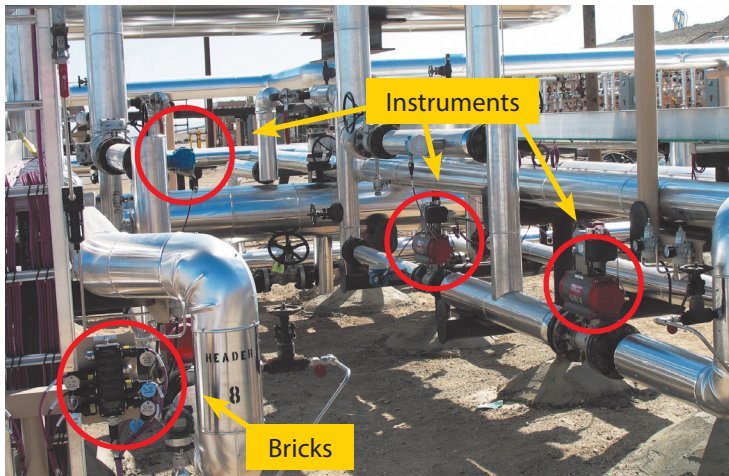

4. Install home run cable tray or supports

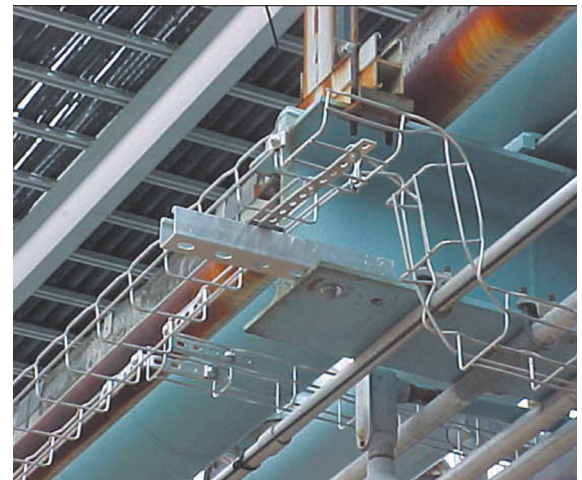

5. Measure main home run cables



- Method 1: Measure the cable tray during installation process.
- Method 2: Use a measuring tape or rope and mark every one meter.
- Method 3: Use a laser measuring tool.



Connectivity | Process Wiring

Process Wiring Physical Layer Guidelines

Process (continue)

6. Install home run cables (brick to control panel)



7. Install brick to instrument tray or supports



8. Measure instruments tray using method 1 - 3, then install instrument cable



We reserve the right to make technical alterations without prior notice.

Connectivity | Process Wiring

What Parts go Together as a System Solution?

4-Port Junction Box Options

Process Wiring Matching Assembly Part Numbers For Class 1 Division 2 Areas

P-4 RKFV 40-RSFV100

P-RSV RKV 40-XXX-*M

- 162 ITC-ER Plum
- 947 ITC Armorfast Plum
- 952 ITC Armorfast Black
- 335 ITC-ER Blue
- 330 ITC-ER Black

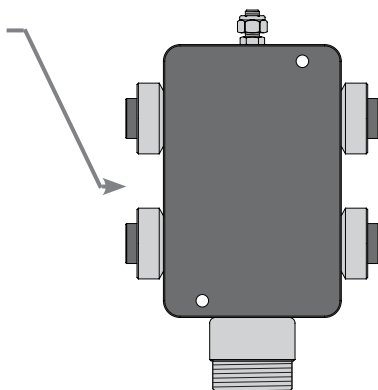

P-RSV RKV 40-XXX-*M

- 162 ITC-ER Plum
- 947 ITC Armorfast Plum
- 952 ITC Armorfast Black
- 335 ITC-ER Blue
- 330 ITC-ER Black

P-4 RKFV 40-CSV12

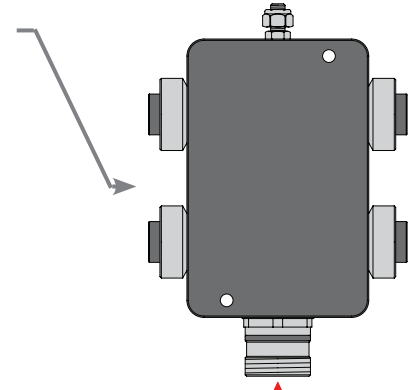

P-RSV RKV 101-XXX-*M

- 978 Basic ITC Blue
- 489 ITC-ER Black 18 AWG
- 2031 ITC-ER Plum 18 AWG

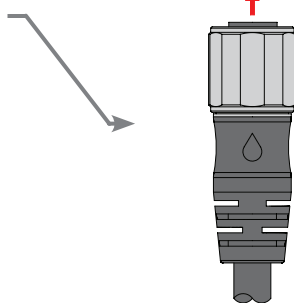

P-CSMT CKMT 12A-XXX-*

- 417 ITC Armorfast Black
- 2152 ITC Armorfast Black 18 AWG

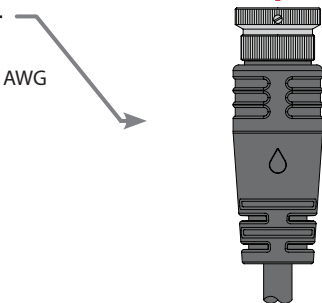

We reserve the right to make technical alterations without prior notice.

Typical Field Instrument Application: Non-Armored ITC-ER

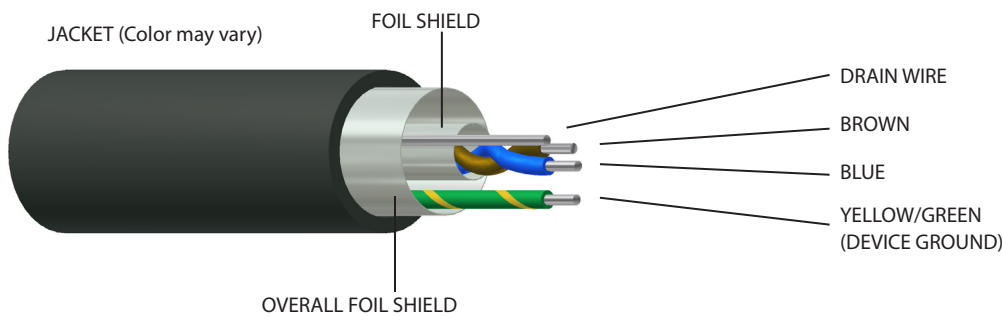

P-RSV RKV 40-XXX-*M

- 162 ITC-ER Plum
- 335 ITC-ER Blue
- 330 ITC-ER Black

2-wire Transmitter

- Brown + 24 VDC
- Blue 4-20 mA signal
- Drain

SPST Valve Switch Contact

- Brown + 24 VDC
- Blue Common

2-wire Valve Solenoid

- Brown + 24 VDC
- Blue Common

* = length in meters

Connectivity | Process Wiring

What Parts go Together as a System Solution?

Typical Field Instrument Application: Armored ITC (Armorfast)

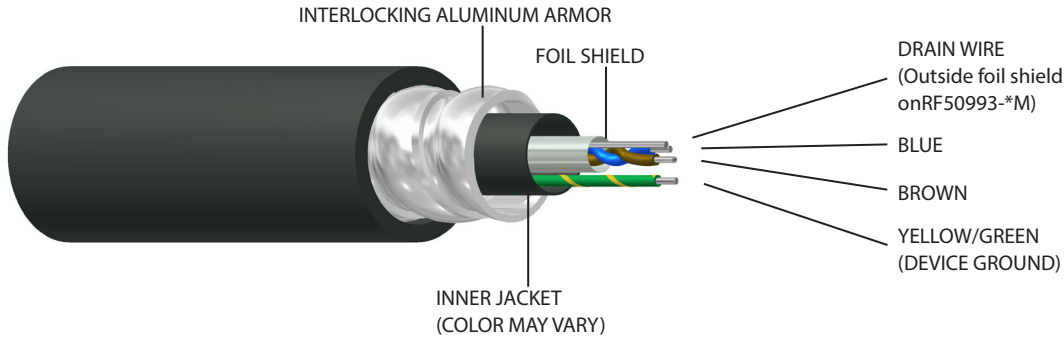

P-RSV RKV 40A-XXX-*M

- 947 ITC Armorfast Plum
- 952 ITC Armorfast Black

2-wire Transmitter

- Brown + 24 VDC
- Blue 4-20 mA signal
- Drain

SPST Valve Switch Contact

- Brown + 24 VDC
- Blue Common

2-wire Valve Solenoid

- Brown + 24 VDC
- Blue Common

Instrument Wire to 4-Port Box Pinout

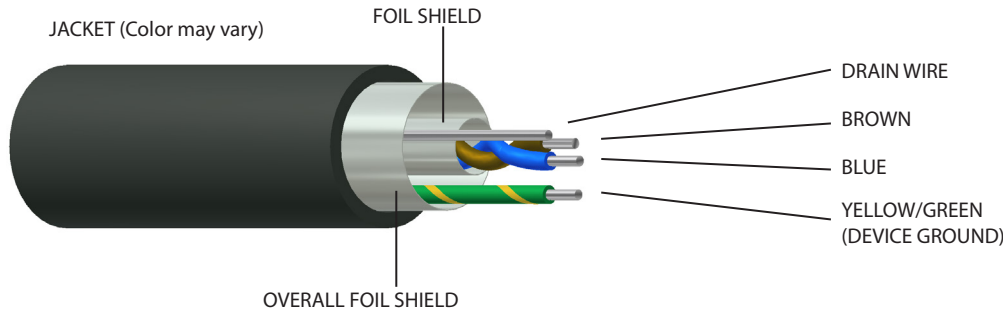

4-Port Junction Box

Transmitter Application

- Pin 1: Blue 4-20 mA
- Pin 2: Brown +24 VDC
- Pin 3: Drain Wire (shield)
- Pin 4: Transmitter Case Ground
Normally not used

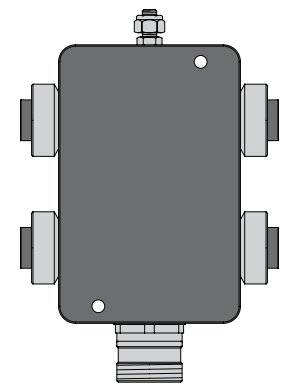
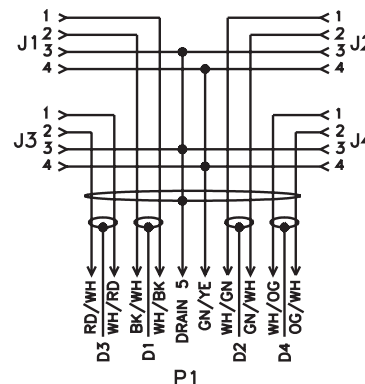

* = length in meters

We reserve the right to make technical alterations without prior notice.

Connectivity | Process Wiring

What Parts go Together as a System Solution?

Single Analog 4-Port Box with ITC-ER, Direct Burial Plum Colored Jacket

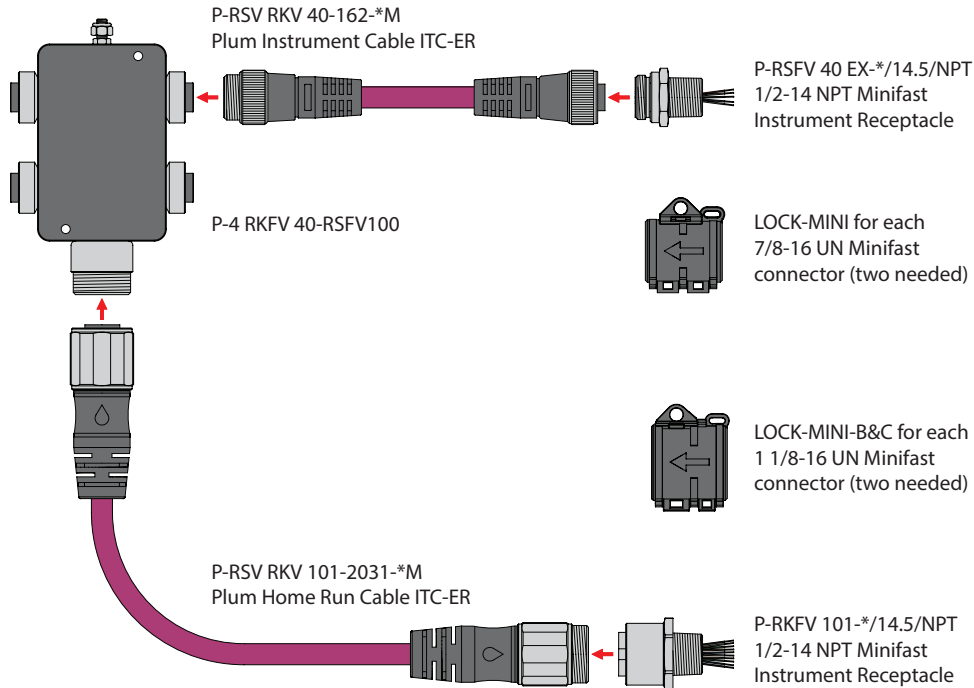

Single Analog 4-Port Box with Armorfast Plum Colored Jacket, ITC-ER Home Run

Use Armorfast Instrument drop cables when customer wants cable that appears stronger than ITC-ER cable.

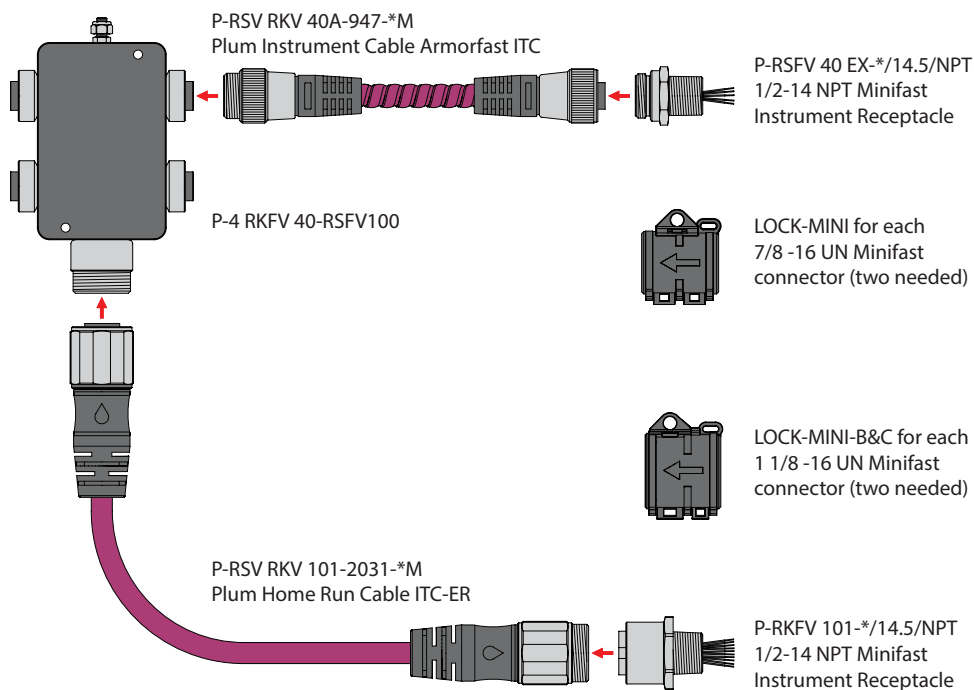

We reserve the right to make technical alterations without prior notice.

* = length in meters

Connectivity | Process Wiring

What Parts go Together as a System Solution?

Single Analog 4-Port Box with ITC-ER, Direct Black Colored Jacket

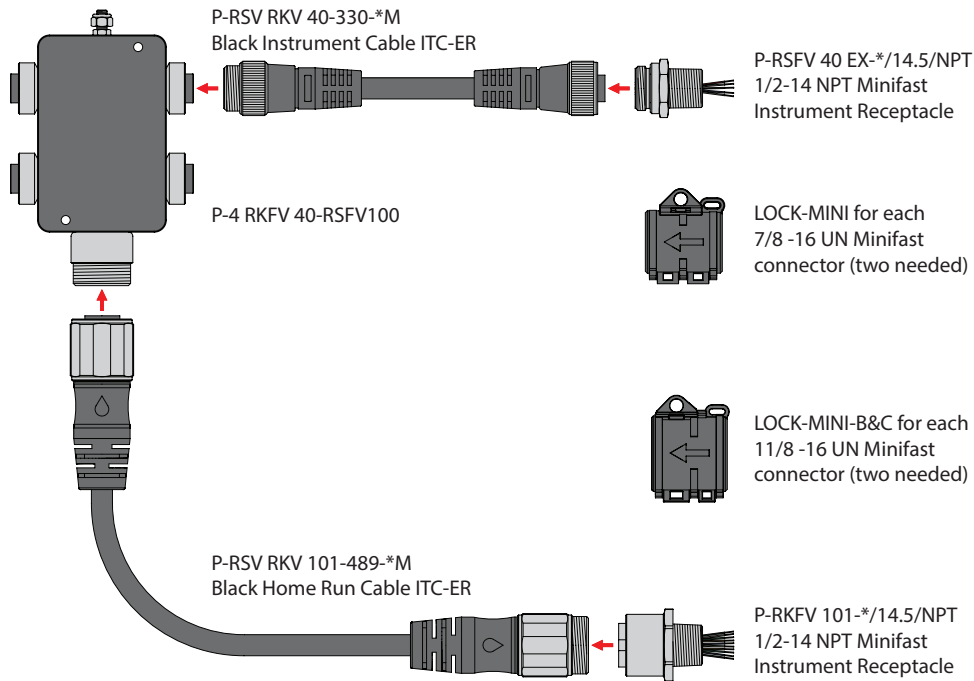

Single Analog 4-Port Box with Armorfast Black Colored Jacket

Use Armorfast cables when a cable stronger than ITC-ER is needed.

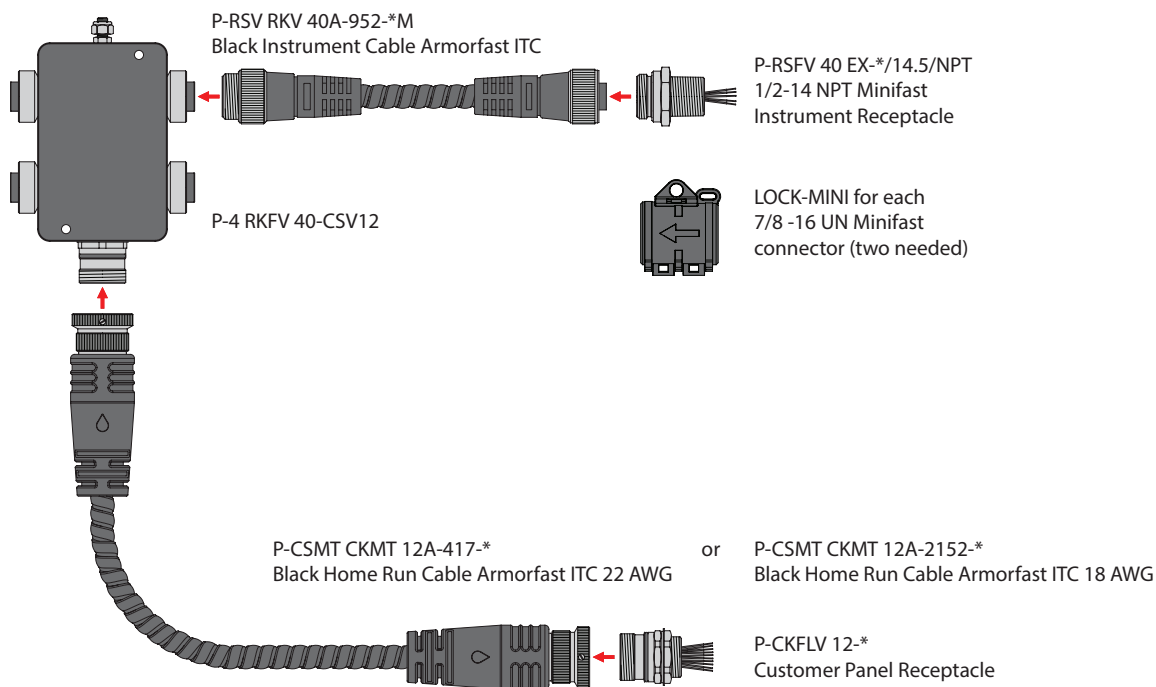

* = length in meters

We reserve the right to make technical alterations without prior notice.

Connectivity | Process Wiring

What Parts go Together as a System Solution?

Division 1 HART/Analog Intrinsic Safety

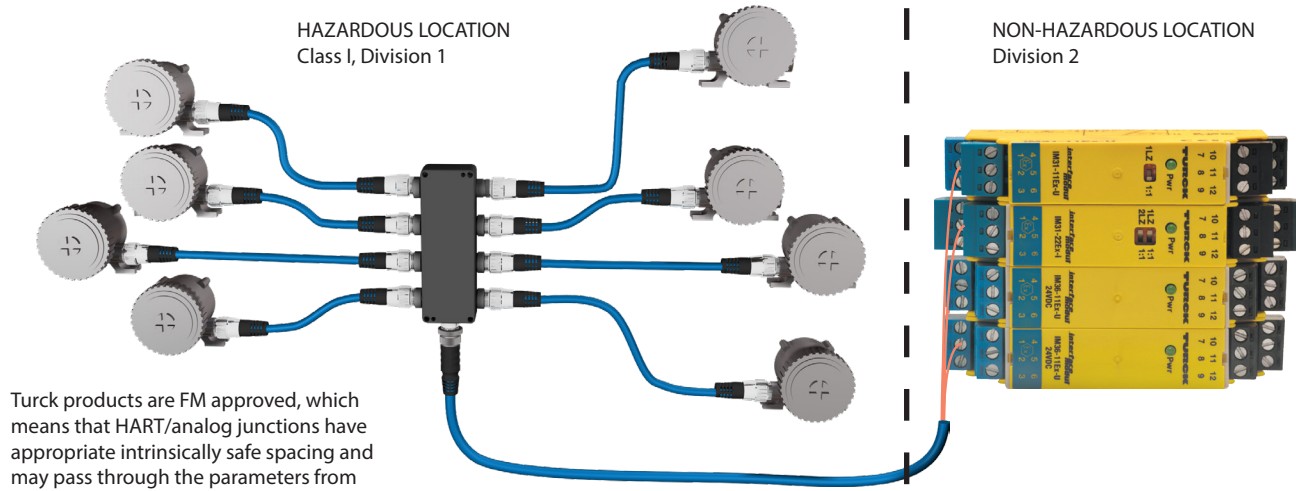

Turck products are FM approved, which means that HART/analog junctions have appropriate intrinsically safe spacing and may pass through the parameters from the barriers.



- Intrinsic safety barrier

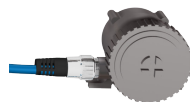

- Intrinsically safe field device with conduit entry-mounted receptacle



- Turck HART Multibox
- Powder-coated aluminum or nylon
- M12 Eurofast or 7/8-16 UN Minifast port connectors. Eurofast, Minifast, M16 or M23 Multifast home-run connector
- Integral home-run cable (not shown)

We reserve the right to make technical alterations without prior notice.

Single Analog 4-Port Box with ITC-ER Intrinsic Safe Blue Colored Jacket, ITC basic Home Run

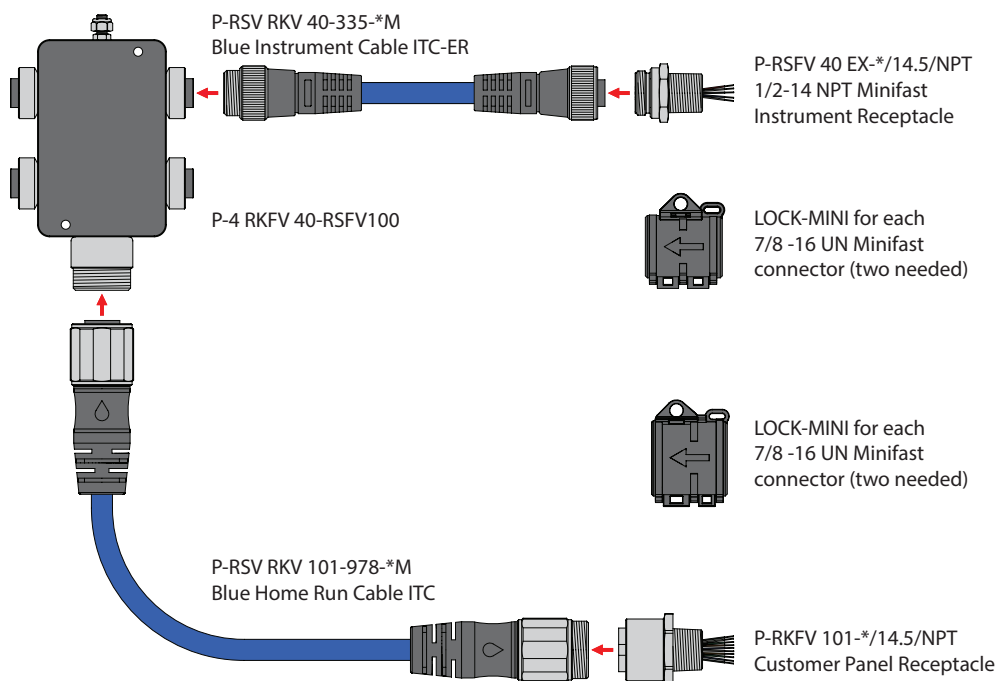

* = length in meters

Connectivity | Process Wiring

4-Port Junction Box for Mixing Valve and Transmitter Applications

Process Wiring Matching Assembly Part Numbers

Typical 2 or 3-Analog Wire and Valve Applications

P-4 RKFV 66-RSFV19

RSV RKV 66-XXX-*M

- 318 ITC-ER Plum
- 494 ITC-ER Black
- 1688 ITC-ER Blue
- 1802 ITC Armorfast Black

Note: This is a 6-pin Minifast cable

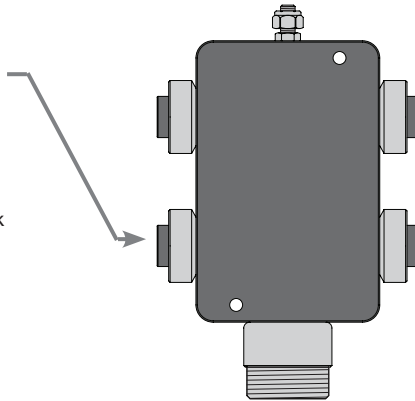

P-RSV RKV 190-XXX-*M

- 1230XL ITC-ER Plum
- 1484XL ITC-ER Black
- 2168XL ITC-ER Blue

Note: This is a 19-pin cable

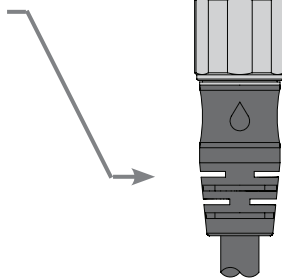

RSV RKV 66-XXX-*M

- 318 ITC-ER Plum
- 494 ITC-ER Black
- 1688 ITC-ER Blue
- 1802 ITC Armorfast Black

Note: This is a 6-pin Minifast cable

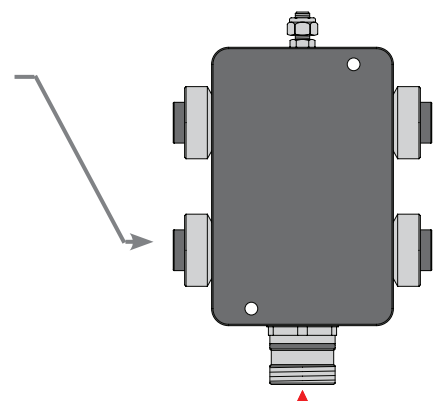

P-CSMT CKMT 19A-419-*

- 419 ITC Armorfast Black

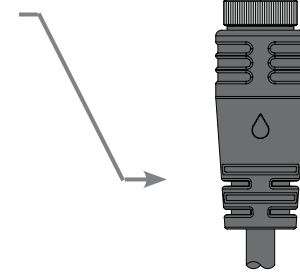

* = length in meters

We reserve the right to make technical alterations without prior notice.

Connectivity | Process Wiring

4-Port Junction Box for Mixing Valve and Transmitter Applications

Typical Field Instrument Application: ITC-ER

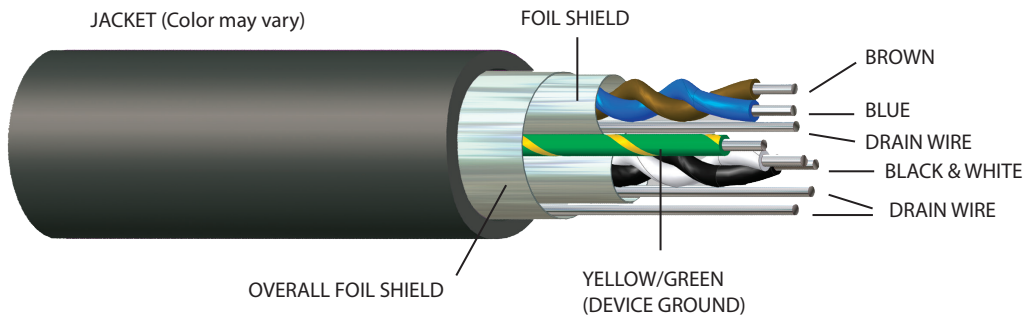

Brown	STP
Blue	
Drain	
Black	STP
White	
Drain	
Green/Yellow Ground	
Overall Drain	

P-RSV RKV 66-XXX-*M

318 ITC-ER Plum

494 ITC-ER Black

1688 ITC-ER Blue

Note: These cables have two shielded twisted pairs with individual drains, an overall drain, and a ground conductor

We reserve the right to make technical alterations without prior notice.

4-Port Box with ITC-ER, Direct Burial Plum Colored Jacket (6-Pin, 2 Analog/Port)

Use with 2 or 3-wire transmitters or valve with Form C contacts or solenoid.

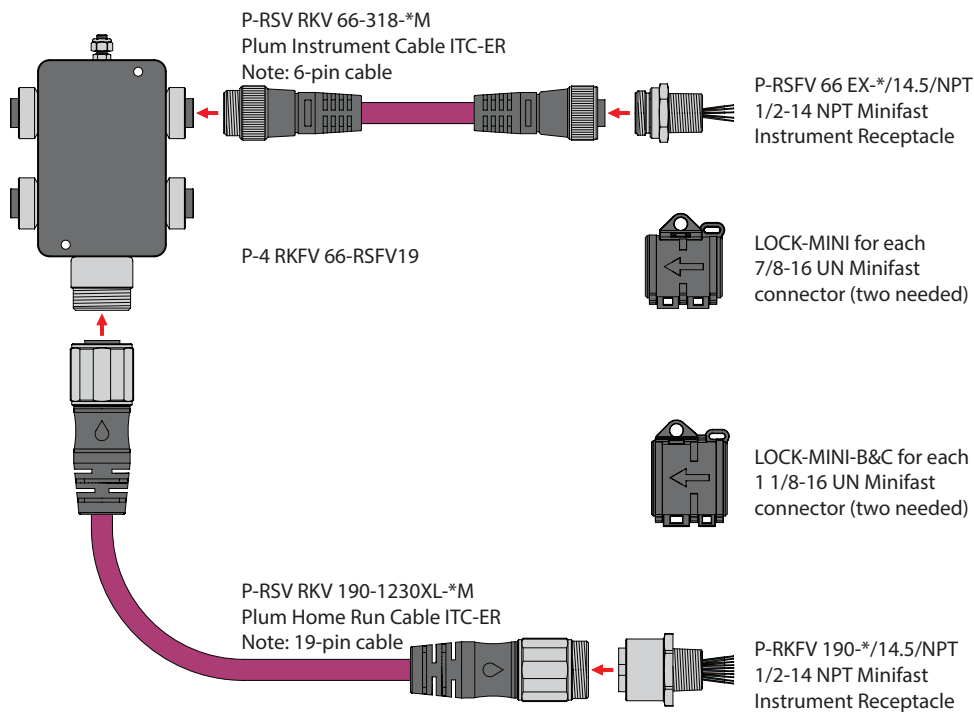

* = length in meters

Connectivity | Process Wiring

4-Port Junction Box for Mixing Valve and Transmitter Applications

4-Port Box with ITC-ER, Direct Burial Black Colored Jacket (6-Pin, 2 Analog/Port)

Use with 2 or 3-wire transmitters or valve with Form C contact or SPST with solenoid.

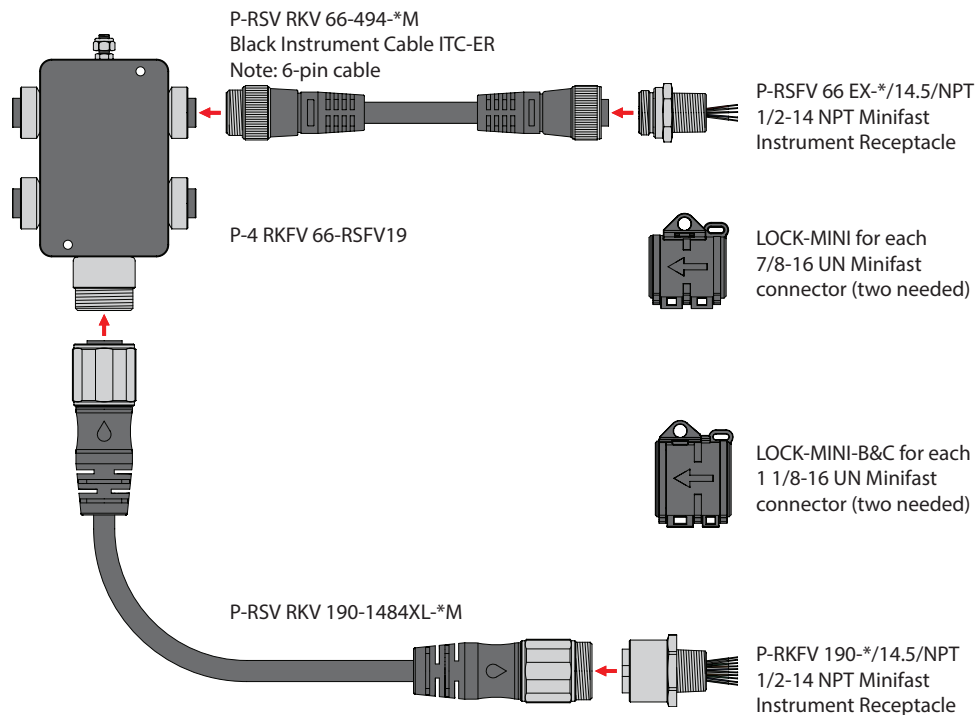

4-Port Box with Armorfast Black Colored Jacket (6-Pin, 2 Analog/Port)

Use with 2 or 3-wire transmitters or valve with Form C contact or SPST with solenoid.

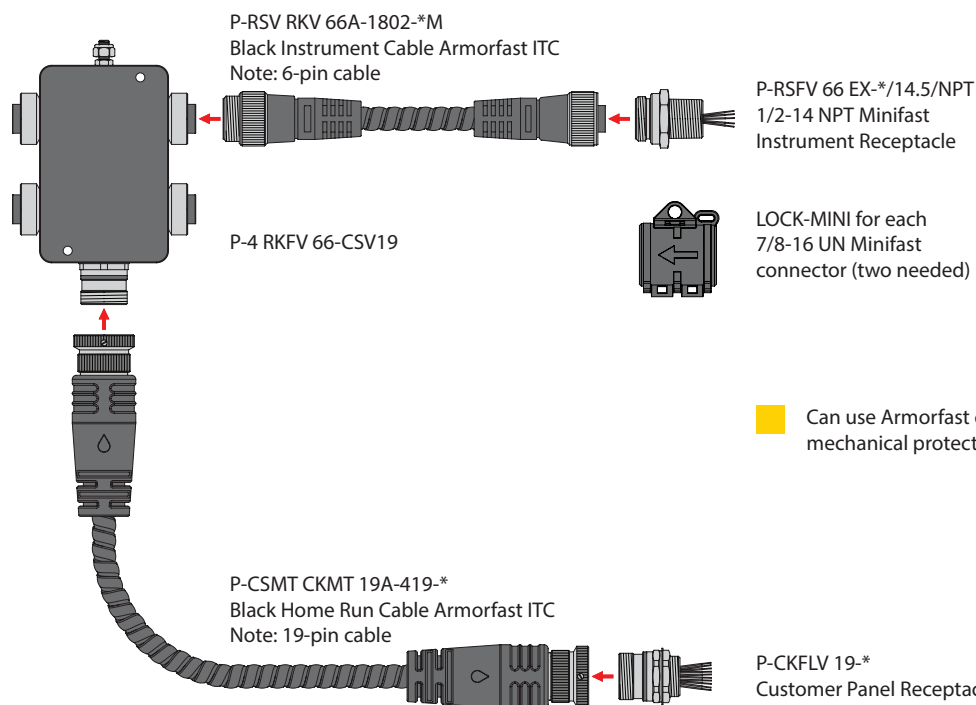

* = length in meters

We reserve the right to make technical alterations without prior notice.

Connectivity | Process Wiring

V-Prox Valve Box Application

Inductive Proximity Sensors for Valve Position Indication

In automated manufacturing and processing plants, position sensors help monitor and control plant processes by confirming that critical activities are completed as intended. More specifically, their primary function is to detect the presence, or absence, of a moving object or 'target'.

The advantages of inductive proximity sensors:

- No physical contact is required
- No moving parts to jam, wear, or break results in less maintenance
- Not affected by dust or dirt

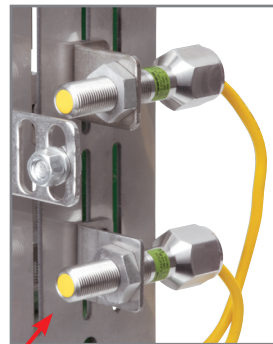

Turck V-Prox
Bi 2.5-EG16CA-FDZ32X2



We reserve the right to make technical alterations without prior notice.

V-Prox 4-Port Box with Grey ITC Drop and Black ITC-ER Direct Burial Colored Jacket

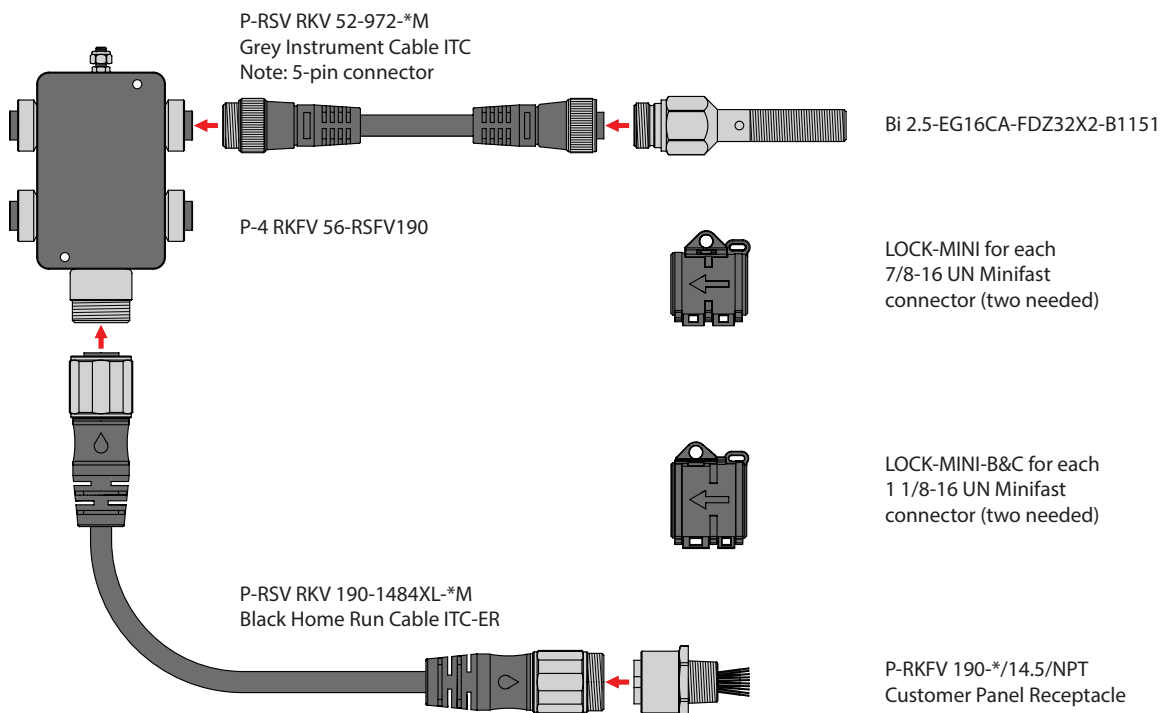

* = length in meters

Connectivity | Process Wiring

8-Port Junction Box Options

Process Wiring Matching Assembly Part Numbers

8- Port Junction Box Cables

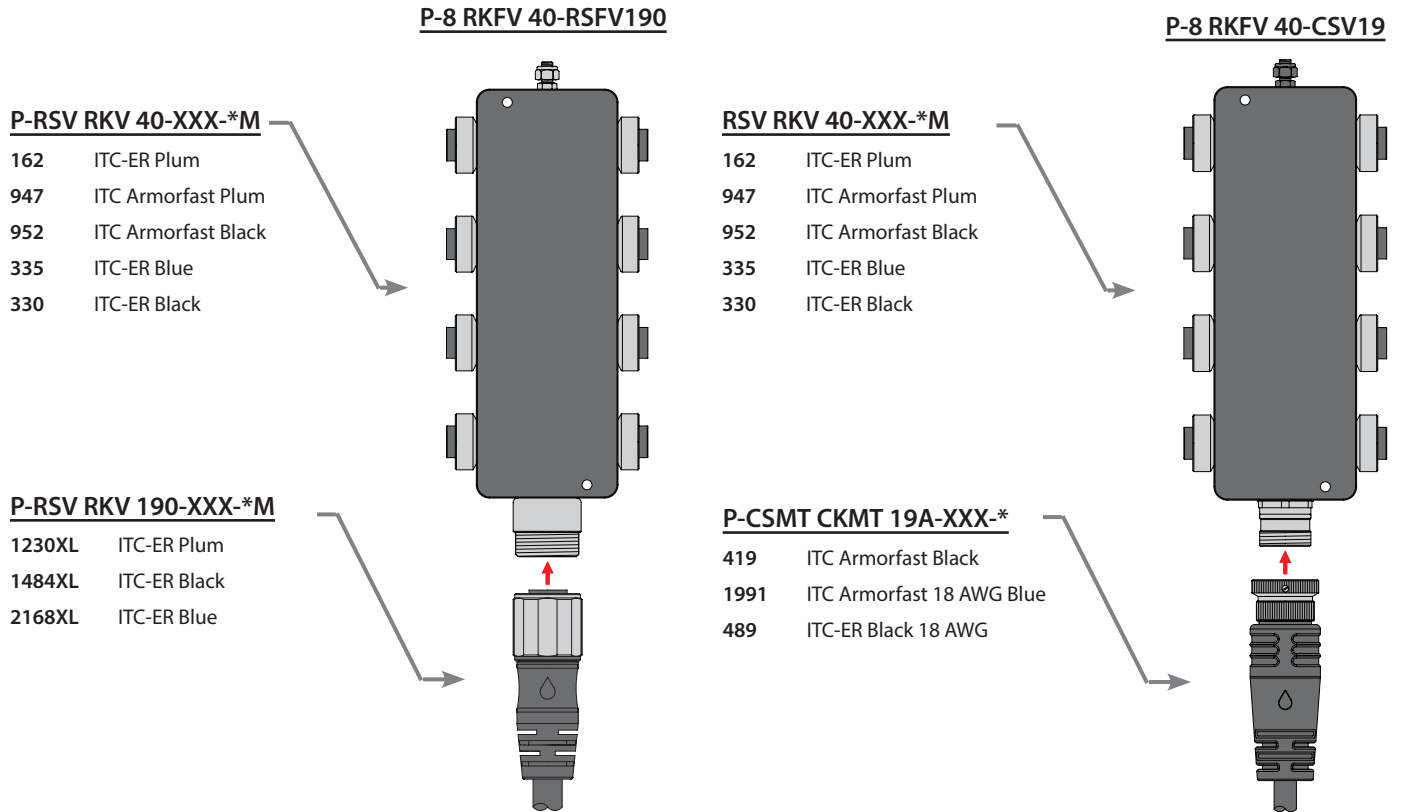

We reserve the right to make technical alterations without prior notice.

Typical Field Instrument Applications: ITC-ER

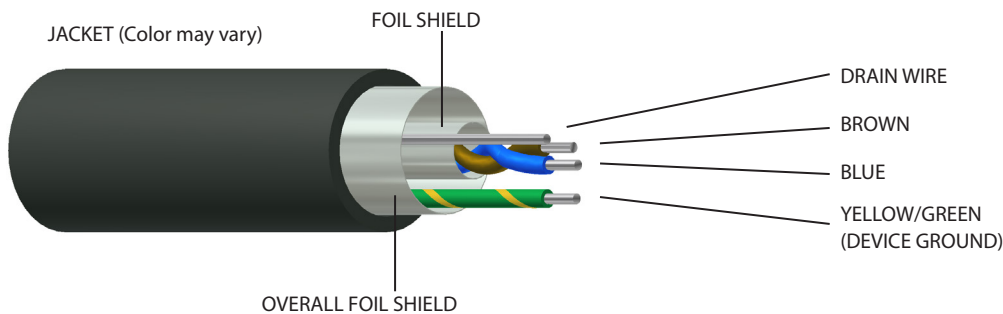

P-RSV RKV 40-XXX-*M

- 162 ITC-ER Plum
- 335 ITC-ER Blue
- 330 ITC-ER Black

2-wire Transmitter

- Brown** + 24 VDC
- Blue** 4-20 mA signal
- Drain**

SPST Valve Switch Contact

- Brown** + 24 VDC
- Blue** Common

2-wire Valve Solenoid

- Brown** + 24 VDC
- Blue** Common

* = length in meters

Connectivity | Process Wiring

8-Port Junction Box Options

Typical Field Instrument Applications: Armored ITC

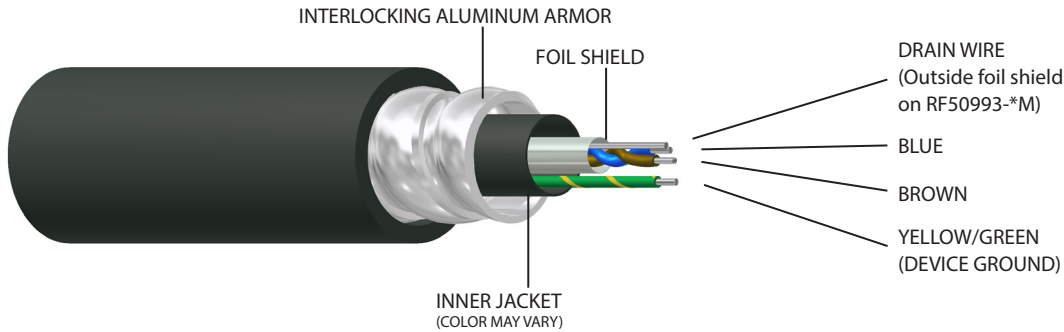

P-RSV RKV 40-XXX-*M

- 947 ITC Armorfast Plum
- 952 ITC Armorfast Black

2-wire Transmitter

- Brown** + 24 VDC
- Blue** 4-20 mA signal
- Drain**

SPST Valve Switch Contact

- Brown** + 24 VDC
- Blue** Common

2-wire Valve Solenoid

- Brown** + 24 VDC
- Blue** Common

We reserve the right to make technical alterations without prior notice.

Instrument Wire to 8-Port Box Pinout

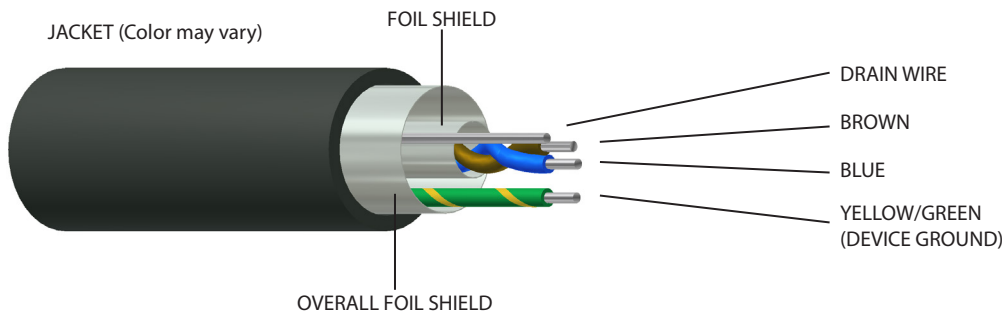

8-Port Junction Box

Transmitter Application

- Pin 1:** Blue 4-20 mA
- Pin 2:** Brown +24 VDC
- Pin 3:** Drain Wire (shield)
- Pin 4:** Transmitter Case Ground
Normally not used

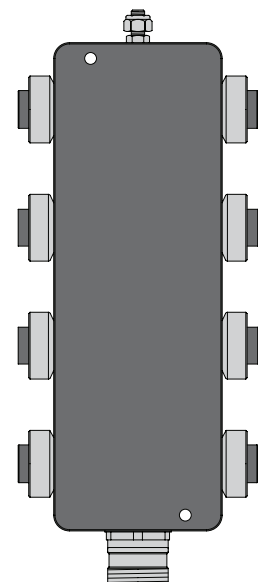
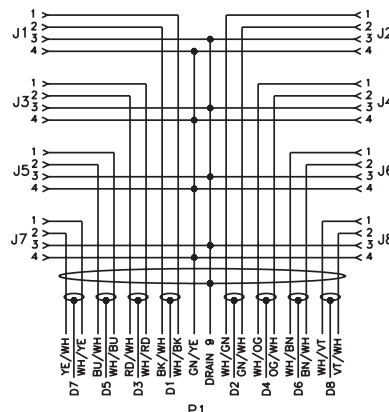

* = length in meters

Connectivity | Process Wiring

8-Port Junction Box Options

Single Analog 8-Port Box ITC-ER, Direct Burial Plum Colored Jacket

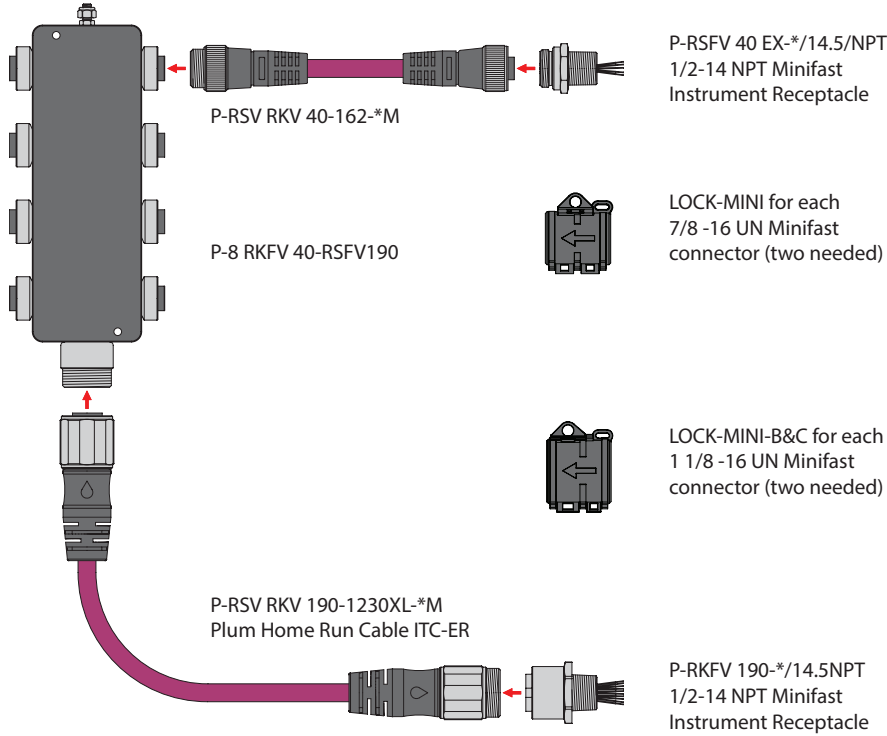

Single Analog 8-Port Box ITC-ER Black Colored Jacket

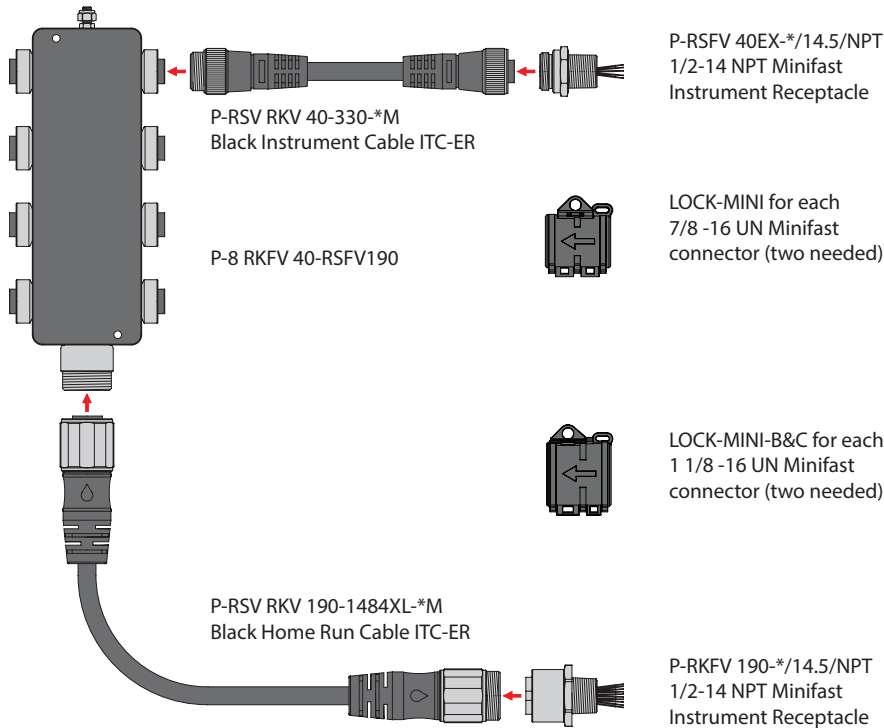

* = length in meters

We reserve the right to make technical alterations without prior notice.

Connectivity | Process Wiring

8-Port Junction Box Options

Single Analog 8-Port Box ITC-ER Intrinsic Safe Blue Colored Jacket

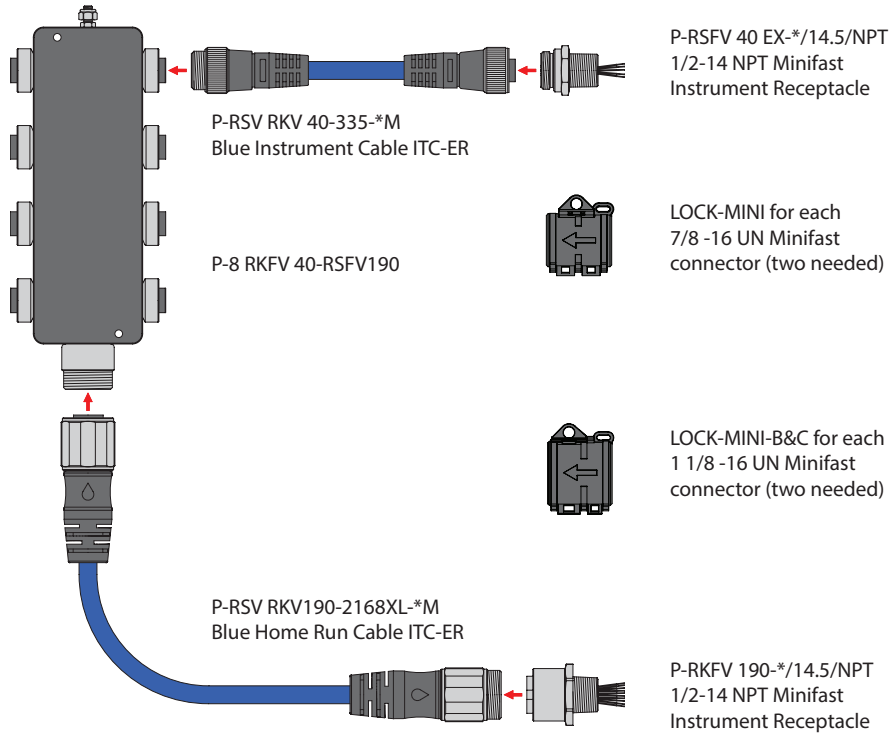

Single Analog 8-Port Box Armorfast Black Colored Jacket

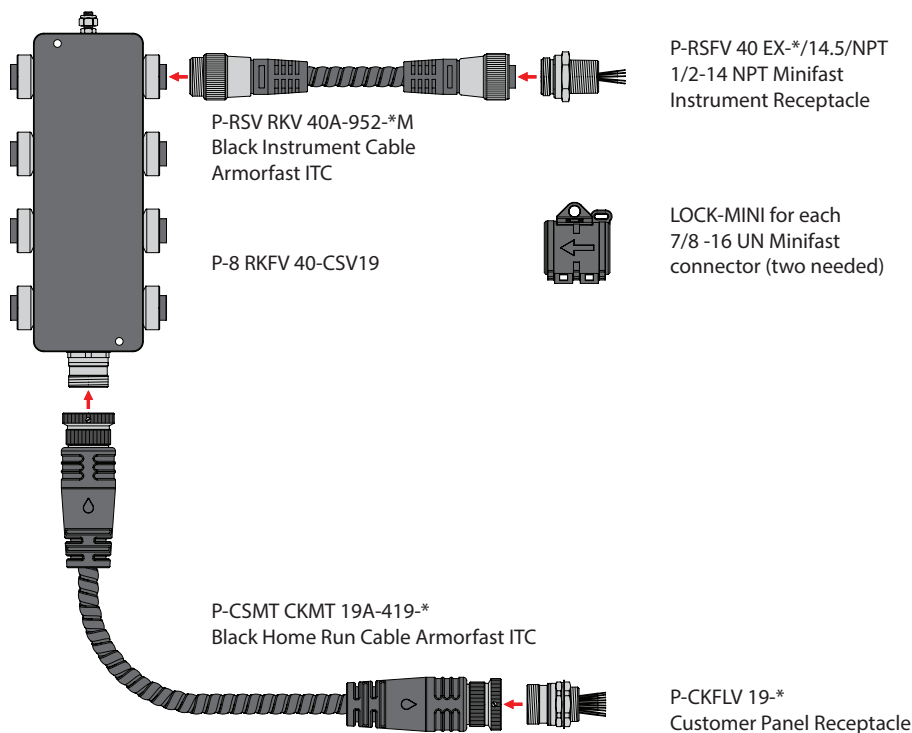

We reserve the right to make technical alterations without prior notice.

* = length in meters

Connectivity | Process Wiring

Retrofit to Existing Division 2 Conduit Systems

Division 2 Conduit System to ITC-ER Direct Burial Plum Colored Jacket

Process Wiring Matching Assembly Part Numbers

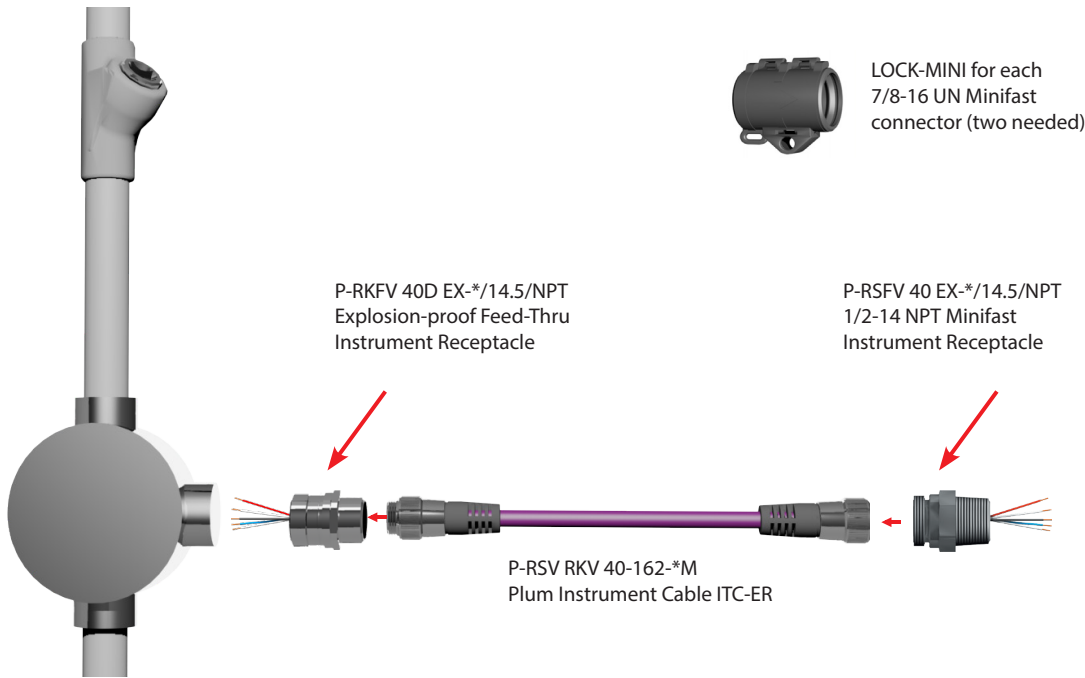

Class I, Division 2 Junction

Division 2 Conduit System to ITC-ER Direct Burial Black Colored Jacket

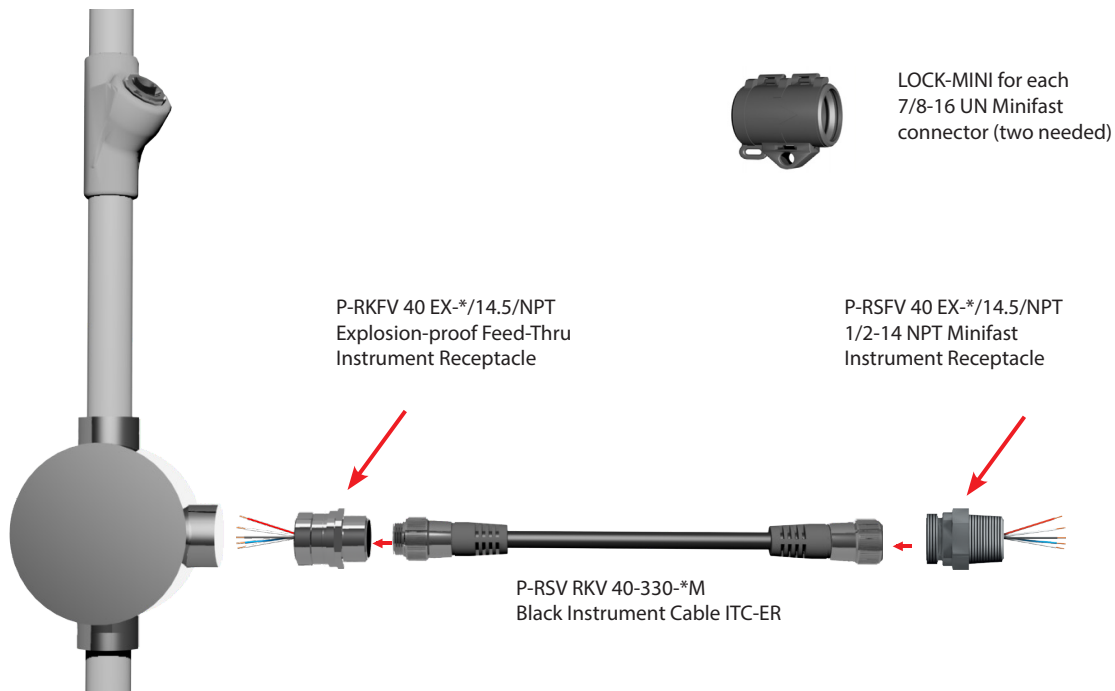

Class I, Division 2 Junction

* = length in meters

We reserve the right to make technical alterations without prior notice.

Connectivity | Process Wiring

Retrofit to Existing Division 2 Conduit Systems

Division 2 Conduit System to ITC Armorfast Black Colored Jacket

We reserve the right to make technical alterations without prior notice.

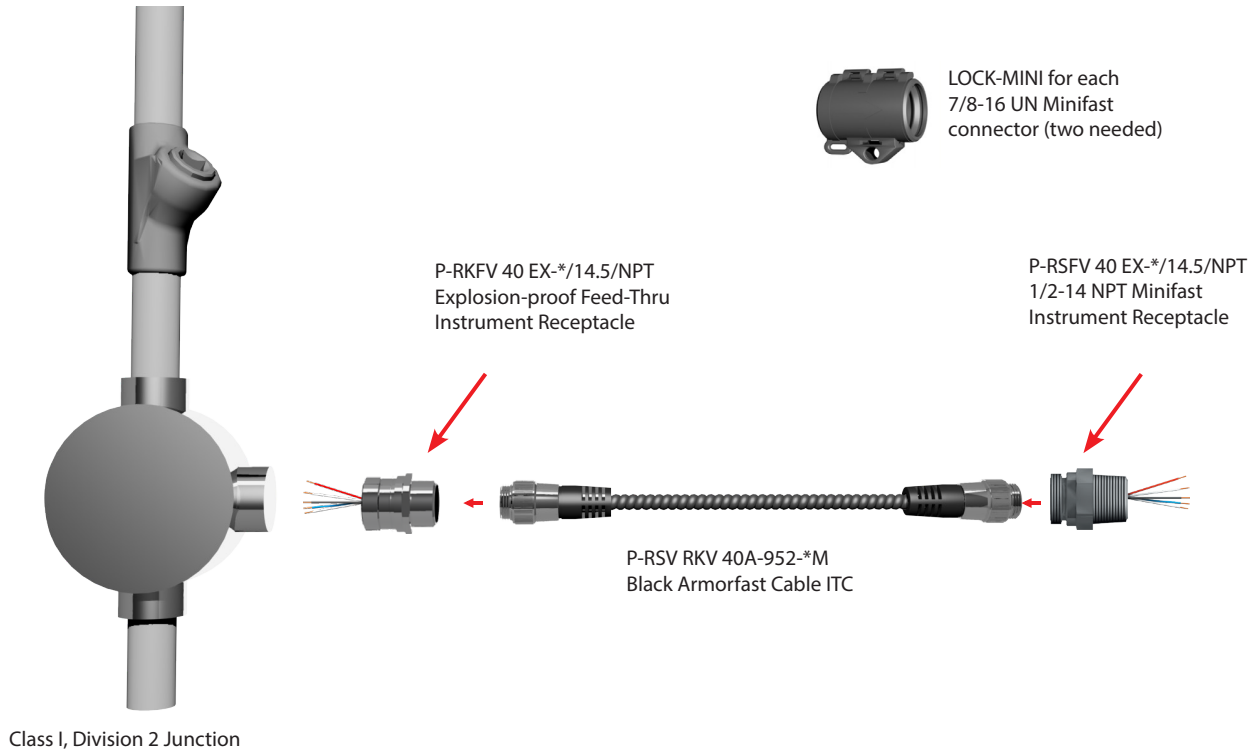

Division 2 Conduit System to ITC-ER Direct Burial Plum Colored Jacket

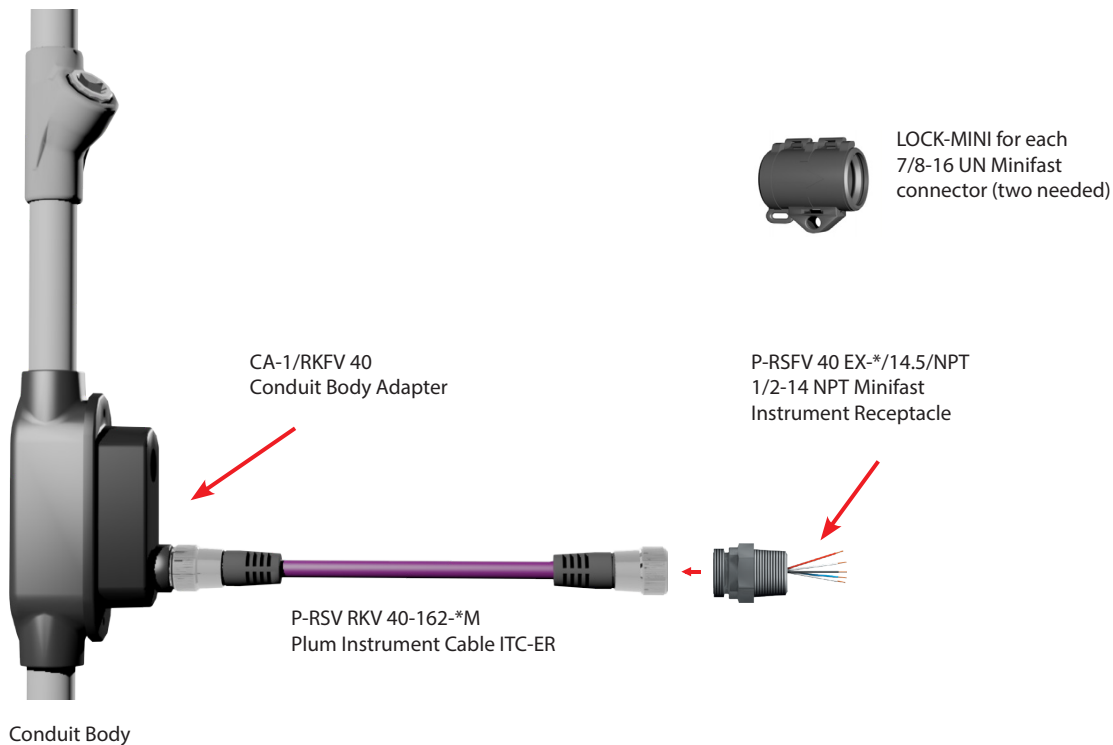

* = length in meters

Connectivity | Process Wiring

Retrofit to Existing Division 2 Conduit Systems

Division 2 Conduit System to ITC-ER Direct Burial Black Colored Jacket

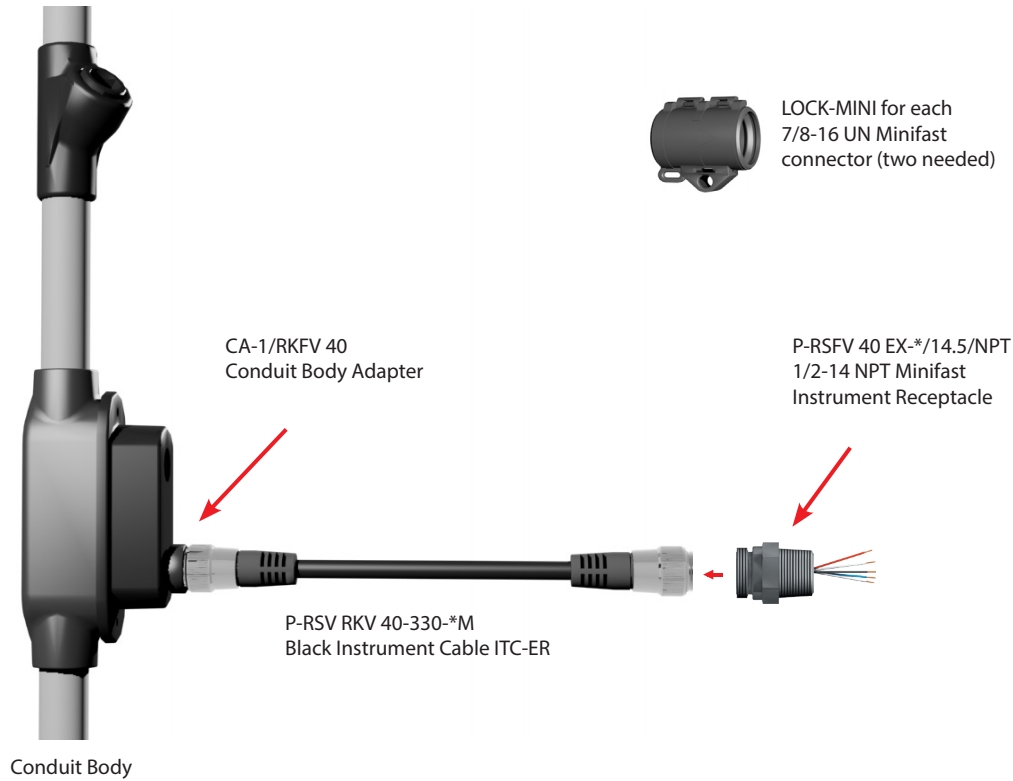

* = length in meters

We reserve the right to make technical alterations without prior notice.

Connectivity | Process Wiring

Harsh Environment Applications

Turck Extremelife-60 cables are heavy duty for extreme temperature environments and provide excellent resistance to oils, sunlight, and abrasion. Turck offers multiple single and twisted pair conductor options.

- Flexible at very cold temperatures
- XLPE insulated conductors provide superior cold performance
- Cables can accommodate popular industrial networks
- Available with braided armor for extreme toughness and offshore hazardous locations

Extremelife-60 Specifications

UL Rating for the US	ITC-ER DB 105 °C; PLTC-ER DB, 105 °C; TC-ER 90 °C Wet/Dry
cUL Rating for Canada	C22.2 No.239-09, CIC; C22.2 No. 230-09, CIC/TC; 90 °C Wet/Dry
Wire Gauge Range	5 to 22 AWG
Cold Bend Pass Temp.	-60 °C
Cold Impact Pass Temp.	-40 °C
Flexible Stranding	Yes
Cut-through and Abrasion Resistance	Very Good
Moisture Resistance	Excellent
Installation Handling	Excellent
Flame Retardancy	IEEE 1202, FT4
Oil Resistance	UL Oil Res I & II
UV Resistance	UL 720 hr Xenon Arc, CSA 1000 hr Weatherometer
Braided Armor	Available with or without
Crush	Meets UL 2225 Requirement for Metal Clad Cables
Impact	

Extremelife-60 Cables

- Standard cables are stocked for quick delivery, and custom designs ship within 6 to 10 weeks
- Multiple designs and custom configurations can be built using 5 to 22 AWG wires and up to 30 conductors, shielded or unshielded
- Tinned copper braided armor
- Wide range of conductor sizes and composite cables available

We reserve the right to make technical alterations without prior notice.

Connectivity | Process Wiring

Harsh Environment Cable: Non-Armored and Braided Armor Construction

Non-Armored

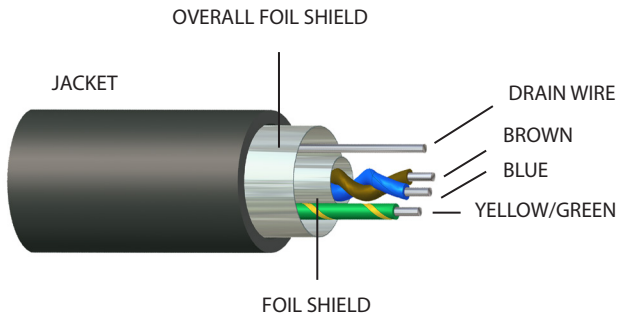

Braided Armor

Armor braided jacket for superior mechanical protection

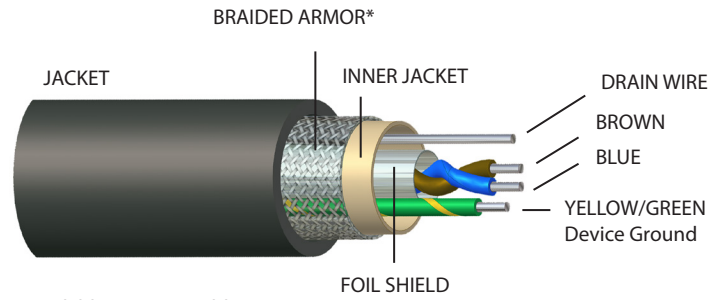

* Available on some cable types

4-Port Junction Box Options

MATCHING ASSEMBLY PART NUMBERS - CLASS 1 DIVISION 2 AREAS

P-RSV RKV 40-XXX-*M

1188XL ITC-ER Extremelife-60 Black (Non-Armored)

RSV RKV 101-XXX-*M

1189XL ITC-ER Extremelife-60 Black (Non-Armored)

P-4 RKFV 40-RSFV100

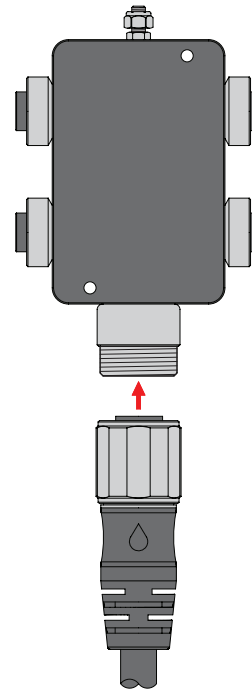

We reserve the right to make technical alterations without prior notice.

* = length in meters

Connectivity | Process Wiring

Harsh Environment: 4-Port Junction Box Options

Typical Field Instrument Applications

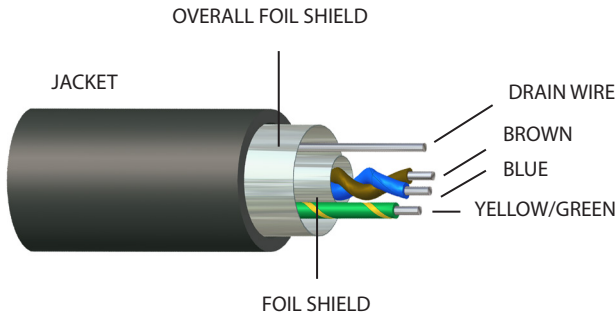

P-RSV RKV 40-XXX-*M

1188XL ITC-ER Extremelife-60 Black (Non-Armored)

2-wire Transmitter

Brown + 24 VDC
Blue 4-20 mA signal
Drain

SPST Valve Switch Contact

Brown + 24 VDC
Blue Common

2-wire Valve Solenoid

Brown + 24 VDC
Blue Common

We reserve the right to make technical alterations without prior notice.

Instrument Wire to 4-Port Box Pinout

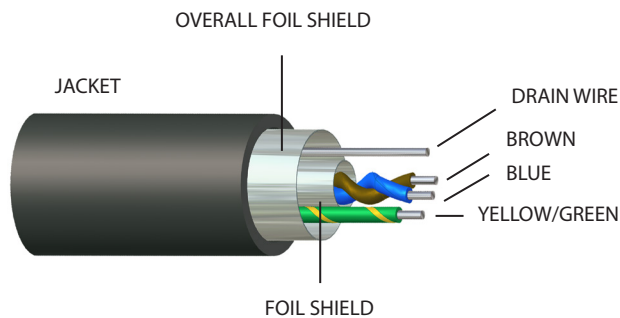

4-Port Junction Box

Transmitter Application

- Pin 1: Blue 4-20 mA
- Pin 2: Brown +24 VDC
- Pin 3: Drain Wire (shield)
- Pin 4: Transmitter Case Ground
Normally not used

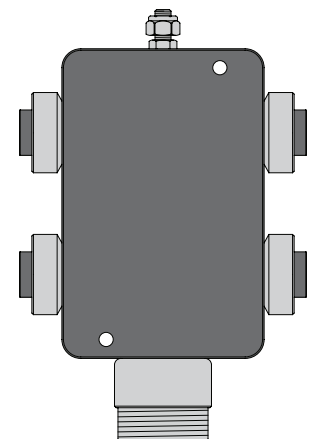
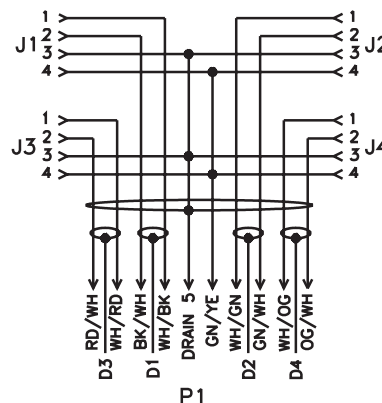

* = length in meters

Connectivity | Process Wiring

Harsh Environment: 4-Port Junction Box Options

Single Analog 4-Port Box with Extremelife-60 Cable Black Colored Jacket Single Analog

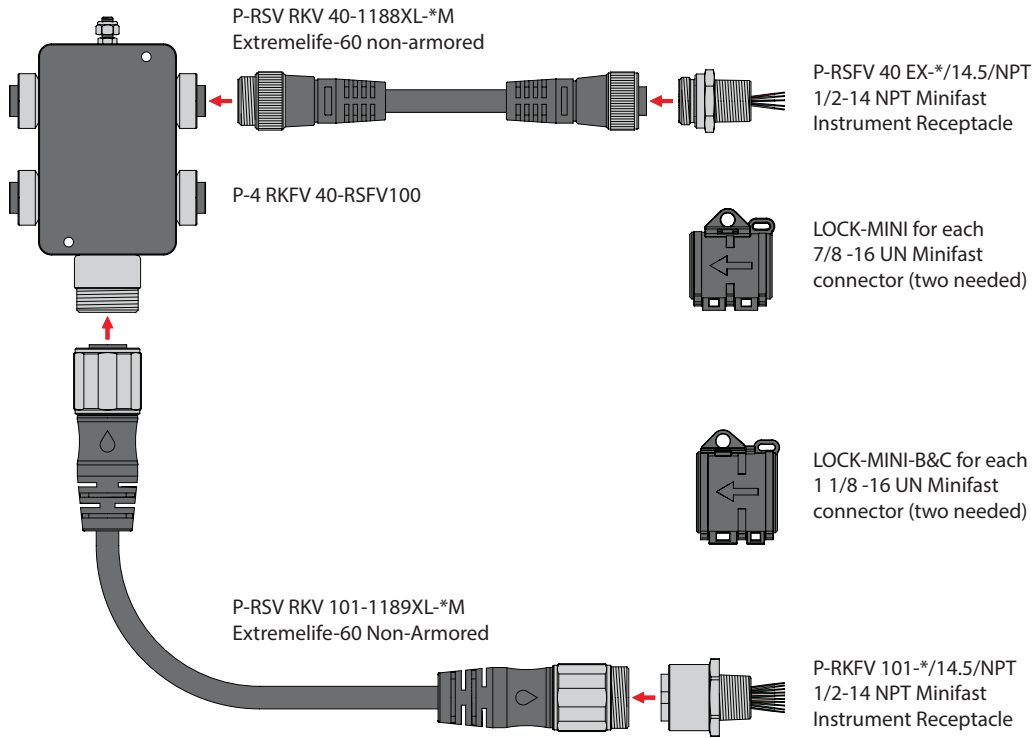

* = length in meters

We reserve the right to make technical alterations without prior notice.

Connectivity | Process Wiring

4-Port Junction Box Options for Mixing Analog and Digital Signals

Matching Assembly Part Numbers - Class I Division 2 Areas

P-4 RKFV 66-RSFV19

P-RSV RKV 66-XXX-*M

2176XL ITC-ER Extremelife-60 Black (Non-Armored)
 Note: This is a 6-pin Minifast cable

P-RSV RKV 19-1484-*M

1484XL ITC-ER Extremelife-60 Black (Non-Armored)
 Note: This is a 19-pin cable

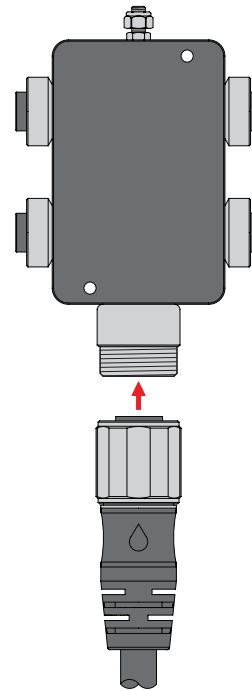

We reserve the right to make technical alterations without prior notice.

Typical Field Instrument Applications

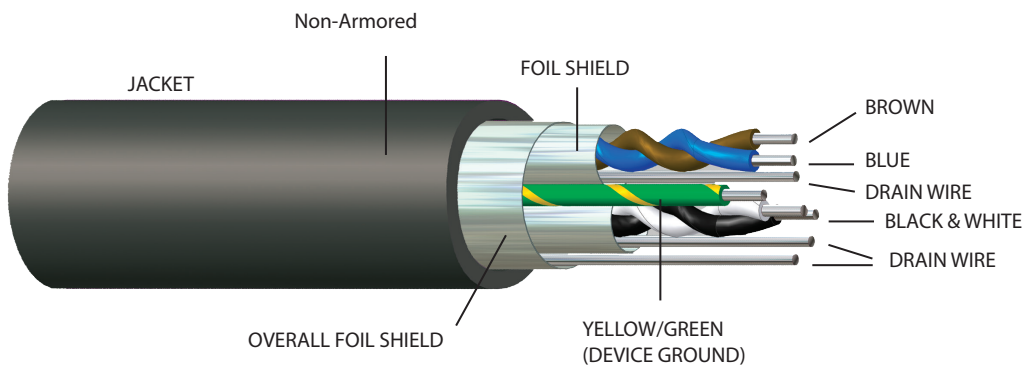

Brown	
Blue	STP
Drain	
Black	
White	STP
Drain	
Green/Yellow Ground	
Overall Drain	

P-RSV RKV 66-XXX-*M

2176XL ITC-ER Extremelife-60 Black (Non-Armored)

Note: These cables have two shielded twisted pairs with individual drains, an overall drain, and a ground conductor

* = length in meters

Connectivity | Process Wiring

4-Port Junction Box Options for Mixing Analog and Digital Signals

4-Port Box with Extremelife-60 Black Colored Jacket (6-pin, 2 Analog/Port)

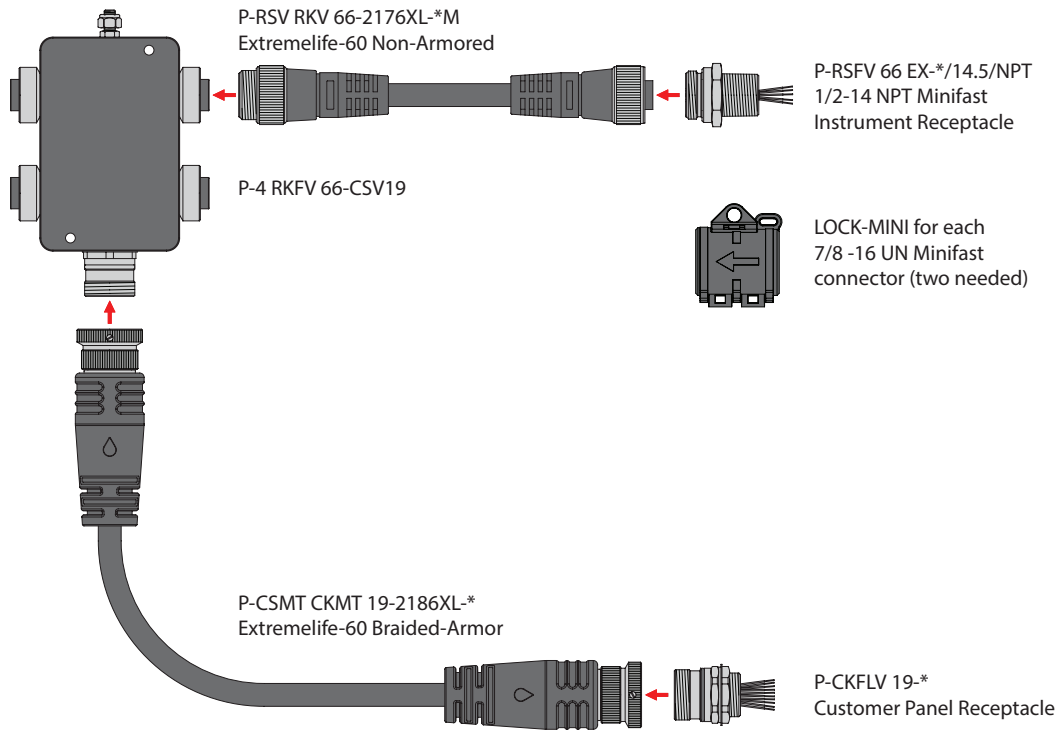

* = length in meters

We reserve the right to make technical alterations without prior notice.

Connectivity | Process Wiring

Harsh Environment Cable: 8-Port Junction Box Options

Matching Assembly Part Numbers - Class I Division 2 Areas

P-RSV RKV 40-XXX-*M

1188XL ITC-ER Extremelife-60 Black (Non-Armored)

P-8 RKFV 40-RSFV190

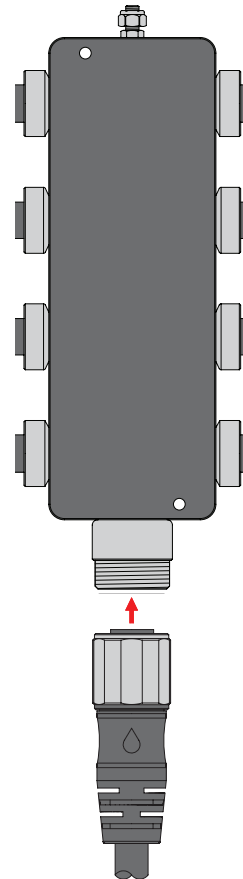

P-RSV RKV 190-XXX-*M

1484XL ITC-ER Extremelife-60 Black (Non-Armored)

We reserve the right to make technical alterations without prior notice.

Typical Field Instrument Applications

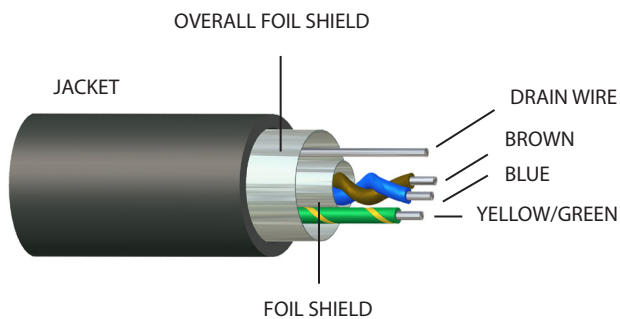

P-RSV RKV 40-XXX-*M

1188XL ITC-ER Extremelife-60 Black (Non-Armored)

2-wire Transmitter

Brown + 24 VDC
Blue 4-20 mA signal
Drain

SPST Valve Switch Contact

Brown + 24 VDC
Blue Common

2-wire Valve Solenoid

Brown + 24 VDC
Blue Common

* = length in meters

Connectivity | Process Wiring

Harsh Environment Cable: 8-Port Junction Box Options

Instruments Wire to 8-Port Box Pinout

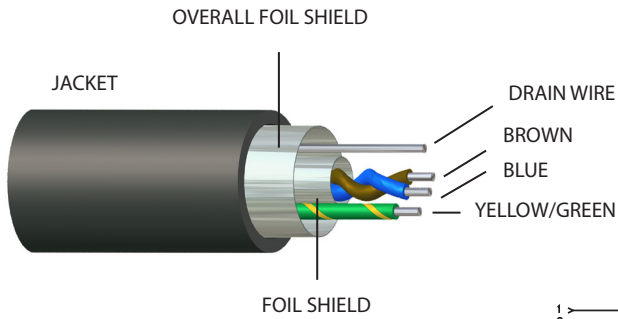

8-Port Junction Box

Transmitter Application

- Pin 1: Blue 4-20 mA
- Pin 2: Brown +24 VDC
- Pin 3: Drain Wire (shield)
- Pin 4: Transmitter Case Ground
Normally not used

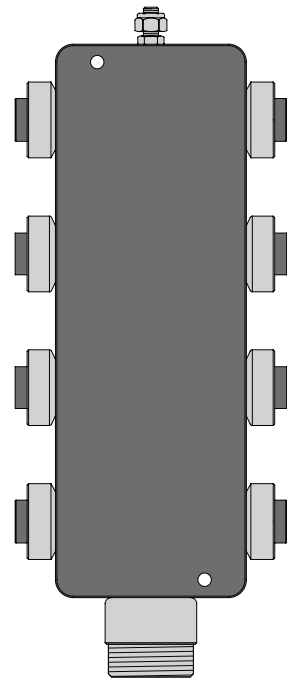
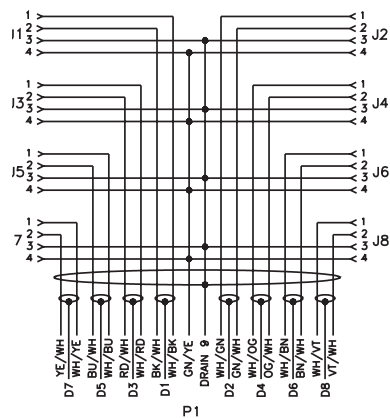

We reserve the right to make technical alterations without prior notice.

Single Analog 8-Port Box with Extremelife-60 Non-Armored Drop Cable Black Colored Jacket

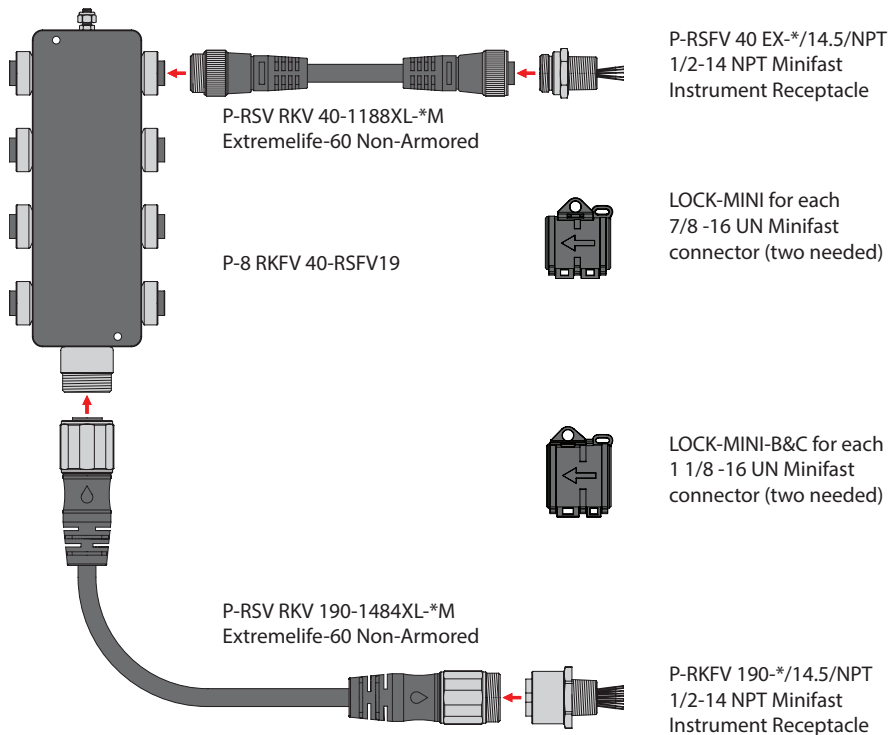

* = length in meters

Connectivity | Process Wiring

Retrofit to Existing Class I Division 2 Conduit System

Division 2 Conduit System to Extremelife-60 Non-Armored Black Colored Jacket

Matching Assembly Part Numbers

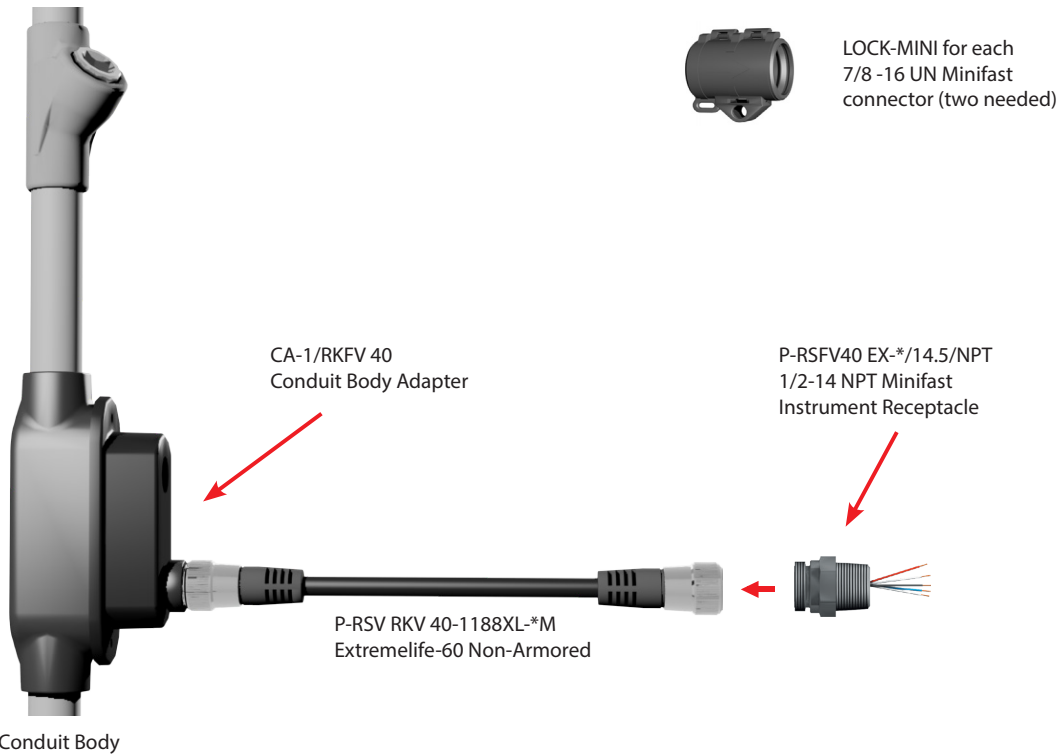

We reserve the right to make technical alterations without prior notice.

Division 2 Conduit System to Extremelife-60 Non-Armored Black Colored Jacket

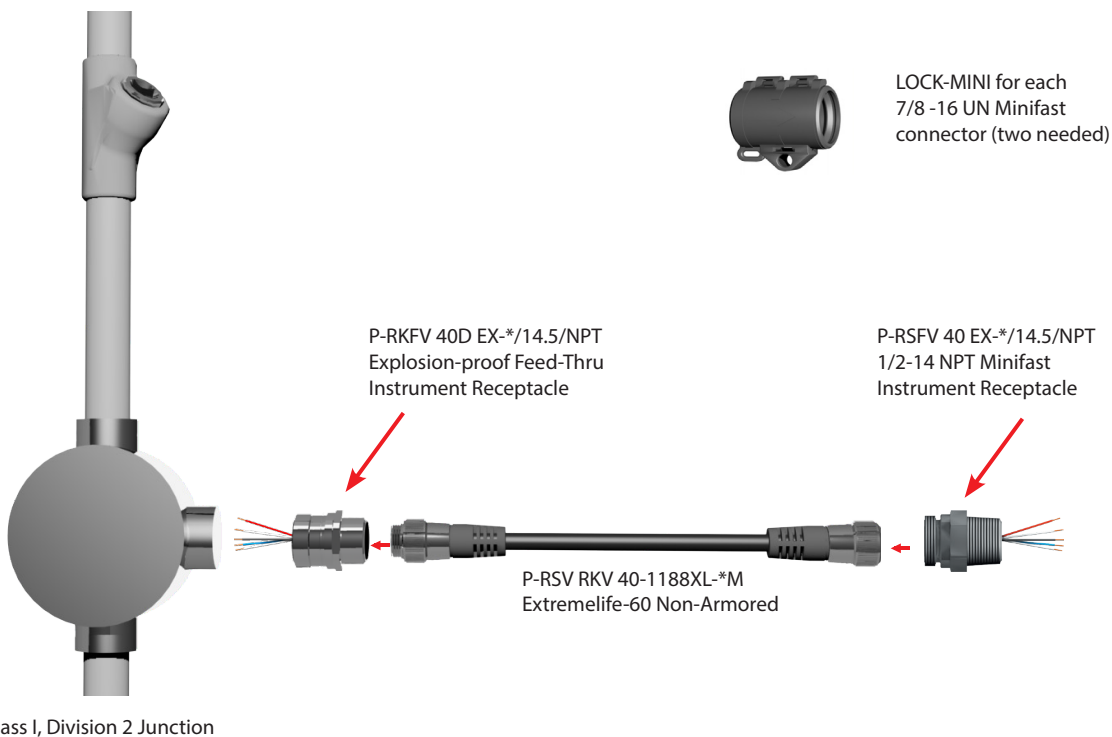

* = length in meters

Connectivity | Process Wiring

AC Power Applications for Control Equipment

Typical TC-ER and TC-ER/STOOW Cables for AC Power



P-PWR-GSDV GKDV 30-xxx-*M

- 1667 TC-ER/STOOW Black
- 1742 TC-ER Black

P-PWR-GSDV GKDV 32-xxx-*M

- 1669 TC-ER/STOOW Black
- 1851 TC-ER Black

P-PWR-GSDV GKDV 34-xxx-*M

- 1671 TC-ER/STOOW Black
- 1198 TC-ER Black

P-PWR-RSV RKV 34-xxx-*M

- 1671 TC-ER/STOOW Black
- 1198 TC-ER Black



P-PWR-GSDV GKDV 40-xxx-*M

- 1666 TC-ER/STOOW Black
- 1743 TC-ER Black

P-PWR-GSDV GKDV 42-xxx-*M

- 1668 TC-ER/STOOW Black
- 1850 TC-ER Black

P-PWR-GSDV GKDV 44-xxx-*M

- 1672 TC-ER/STOOW Black
- 1193 TC-ER Black

P-PWR-RSV RKV 44-xxx-*M

- 1672 TC-ER/STOOW Black
- 1750 TC-ER Black

We reserve the right to make technical alterations without prior notice.

* = length in meters

Connectivity | Process Wiring

AC Power Applications for Control Equipment

Typical Single-Phase Supply for Actuators and Small Motors up to 600 V/30 A



P-PWR-GKDFV 30-*/14.5/NPT

1/2-14 NPT Powerfast® receptacle
1 3/8-16 UN female mating thread
10 AWG leads

P-PWR-GSDV GKDV 30-1667-*/M

Black TC-ER/STOOW cable, 10 AWG

P-PWR-GSDFV 30-*/M/14.5/NPT

1/2-14 NPT Powerfast receptacle
1 3/8-16 UN male mating thread
10 AWG leads



P-PWR-GKDFV 32-*/M/14.5/NPT

1/2-14 NPT Powerfast receptacle
1 3/8-16 UN female mating thread
12 AWG leads

P-PWR-GSDV GKDV 32-1669-*/M

Black TC-ER/STOOW cable, 12 AWG

P-PWR-GSDFV 32-*/M/14.5/NPT

1/2-14 NPT Powerfast receptacle
1 3/8-16 UN male mating thread
12 AWG leads



P-PWR-GKDFV 34-*/M/14.5/NPT

1/2-14 NPT Powerfast receptacle
1 3/8-16 UN female mating thread
14 AWG leads

P-PWR-GSDV GKDV 34-1671-*/M

Black TC-ER/STOOW cable, 14 AWG

P-PWR-GSDFV 34-*/M/14.5/NPT

1/2-14 NPT Powerfast receptacle
1 3/8-16 UN male mating thread
14 AWG leads

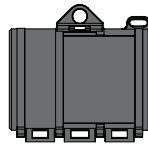

LOCK-MINI-D for each
1 3/8 UN Powerfast
connector (two needed)

Typical Single-Phase Supply for Actuators and Small Motors up to 600 V/15 A



P-PWR-RKFV 34-*/14.5/NPT

1/2-14 NPT Powerfast receptacle
1 3/8-16 UN female mating thread
14 AWG leads

P-PWR-RSV RKV 34-1671-*/M

Black TC-ER/STOOW cable, 14 AWG

P-PWR-RSFV 34-*/14.5/NPT

1/2-14 NPT Powerfast receptacle
1 3/8-16 UN female mating thread
14 AWG leads

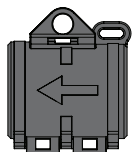

LOCK-MINI for each
7/8-16 UN Powerfast
connector (two needed)

* = length in meters

Connectivity | Process Wiring

AC Power Applications for Control Equipment

Typical Three-Phase Supply For Actuators and Small Motors up to 600 V/30 A



P-PWR-GKDFV 40-*/14.5/NPT

1/2-14 NPT Powerfast receptacle
1 3/8-16 UN female mating thread
10 AWG leads

P-PWR-GSDV GKDV 40-1666-*/M

Black TC-ER/STOOW cable, 10 AWG

P-PWR-GSDFV 40-*/M/14.5/NPT

1/2-14 NPT Powerfast receptacle
1 3/8-16 UN male mating thread
10 AWG leads



P-PWR-GKDFV 42-*/M/14.5/NPT

1/2-14 NPT Powerfast receptacle
1 3/8-16 UN female mating thread
12 AWG leads

P-PWR-GSDV GKDV 42-1666-*/M

Black TC-ER/STOOW cable, 12 AWG

P-PWR-GSDFV 42-*/M/14.5/NPT

1/2-14 NPT Powerfast receptacle
1 3/8-16 UN male mating thread
12 AWG leads



P-PWR-GKDFV 44-*/M/14.5/NPT

1/2-14 NPT Powerfast receptacle
1 3/8-16 UN female mating thread
14 AWG leads

P-PWR-GSDV GKDV 44-1672-*/M

Black TC-ER/STOOW cable, 14 AWG

P-PWR-GSDFV 44-*/M/14.5/NPT

1/2-14 NPT Powerfast receptacle
1 3/8-16 UN male mating thread
14 AWG leads

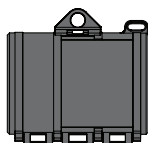

LOCK-MINI-D for each
1 3/8 UN Powerfast
connector (two needed)

Typical Three-Phase Supply for Actuators and Small Motors up to 600 V/15 A



P-PWR-RKFV 44-*/14.5/NPT

1/2-14 NPT Powerfast receptacle
1 3/8-16 UN female mating thread
14 AWG leads

P-PWR-RSV RKV 44-1672-*/M

Black TC-ER/STOOW cable, 14 AWG

P-PWR-RSFV 44-*/14.5/NPT

1/2-14 NPT Powerfast receptacle
1 3/8-16 UN female mating thread
14 AWG leads

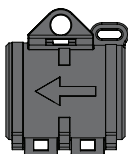

LOCK-MINI for each
7/8-16 UN Powerfast
connector (two needed)

* = length in meters

We reserve the right to make technical alterations without prior notice.

Connectivity | Process Wiring

Retrofit to Existing Class I Division 2 Conduit System

Typical Single-Phase Division 2 Conduit System to TC-ER/STOOW Direct Burial Black Colored Jacket

Process Wiring Matching Assembly Part Numbers

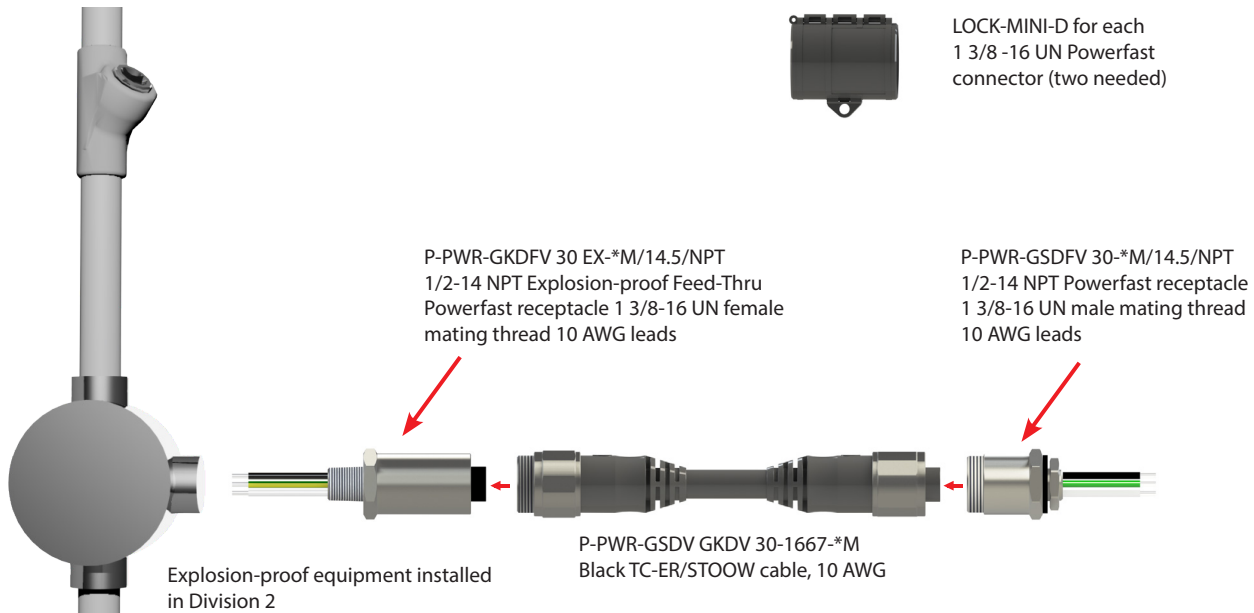

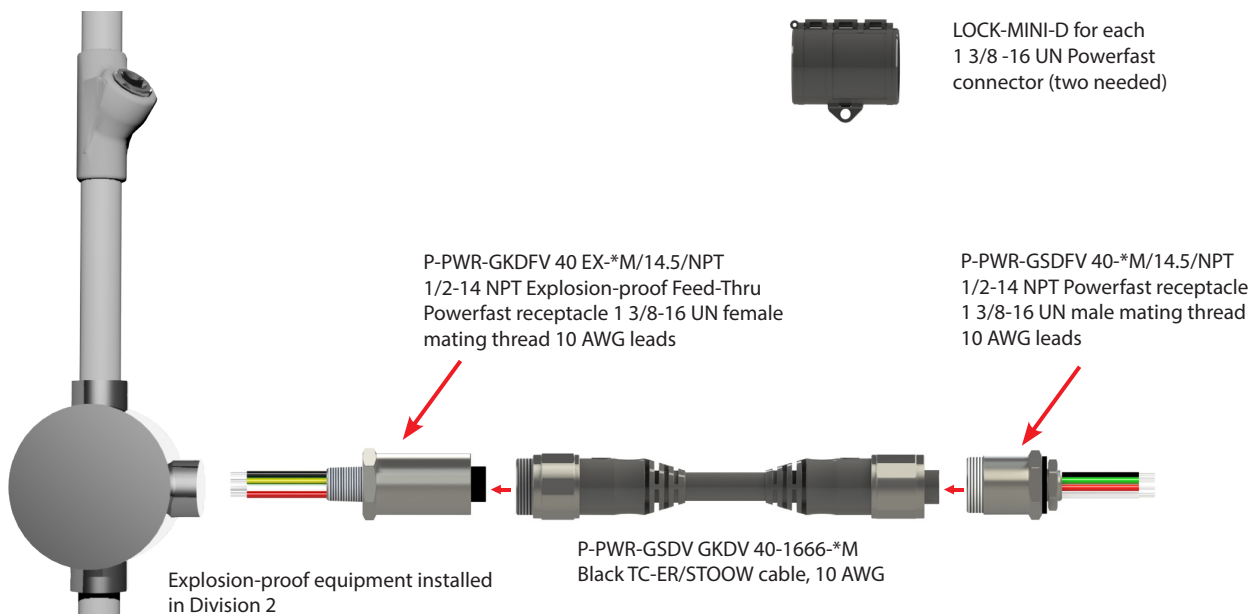

Typical Three-Phase Division 2 Conduit System to TC-ER/STOOW Direct Burial Black Colored Jacket



* = length in meters

Connectivity | Process Wiring

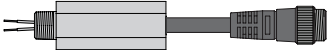
Midstream applications require reliable and rugged automation solutions to keep your production processes up and running. Turck has solutions to answer the demanding needs of midstream applications where your goods are in constant motion; solutions that can withstand shock and vibration, provide environmental protection, and allow for reliable network and I/O communication.

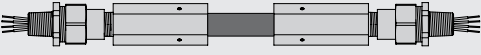
Assembly reference (note: conductor count may vary from picture)	1 Pair + Ground	2 Pair + Ground	2 Pair + Ground + Drain	4 Pair + Ground + Drain
	P-RSV 40-EXG-2524XL-*/*/14.5/NPT	P-RSV 562-EXG-2574-*/*/14.5/NPT	P-RSV 66-EXG-2574-*/*/14.5/NPT	P-RSV101 562-EXG-2525-*/*/14.5/NPT
	P-RSV 40-EXG-2524XL-*/*/14.5/NPT/UNION	P-RSV 562-EXG-2574-*/*/14.5/NPT/UNION	P-RSV 66-EXG-2574-*/*/14.5/NPT/UNION	P-RSV101 562-EXG-2525-*/*/14.5/NPT/UNION
	P-EXG 2A1-2524*/*/14.5/NPT	P-EXG 2A4-2574*/*/14.5/NPT	P-EXG 2A3-2574*/*/14.5/NPT	P-EXG 2A2-2525*/*/14.5/NPT
	P-EXG 2A1-2524*/*/14.5/NPT/UNION	P-EXG 2A4-2574*/*/14.5/NPT/UNION	P-EXG 2A3-2574*/*/14.5/NPT/UNION	P-EXG 2A2-2525*/*/14.5/NPT/UNION

We reserve the right to make technical alterations without prior notice.

Note: First asterisk is the length of the jacketed cable in meters. Second asterisk is the wire lead length in meters.

Connectivity | Process Wiring

MC-HL Receptacle Extensions

Typical Field Applications

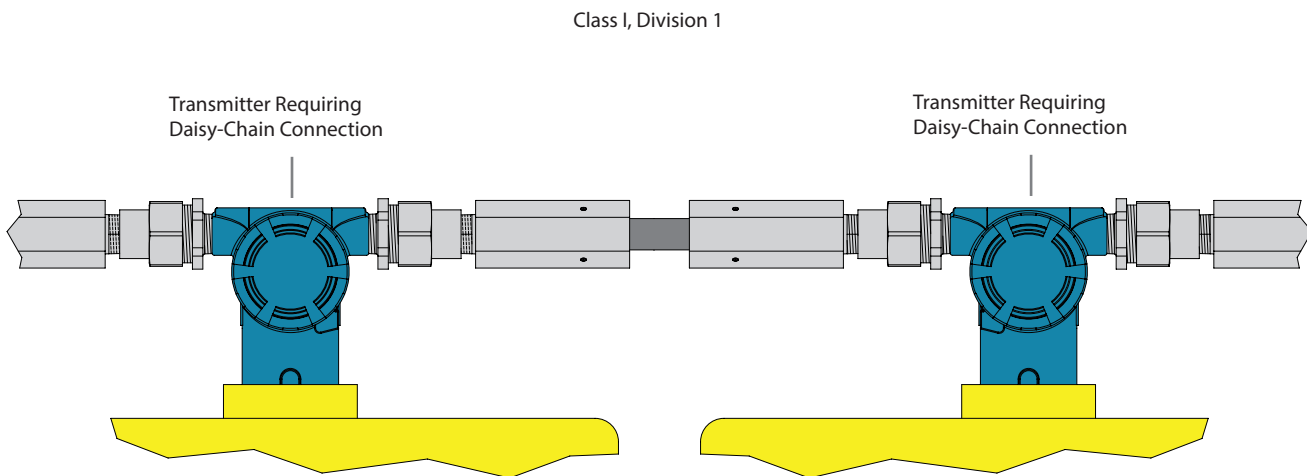
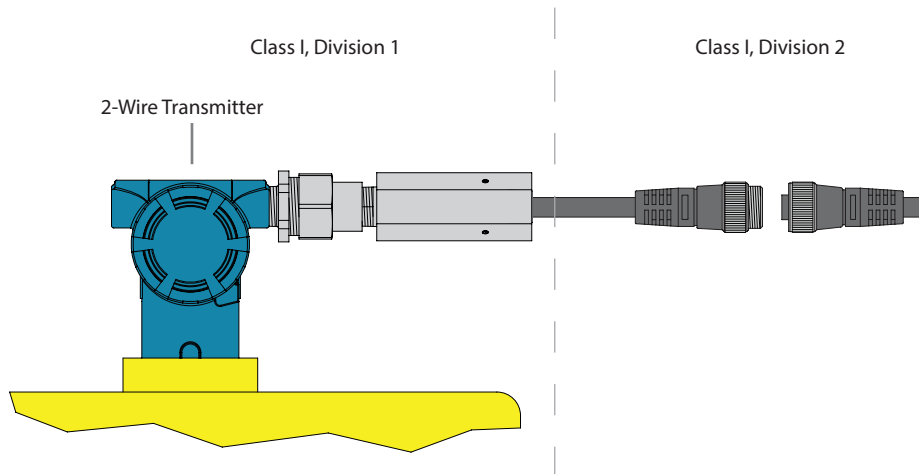

We reserve the right to make technical alterations without prior notice.

Note: Connections with Class I, Division 2 locations require the use of a Lockfast guard.

* = length in meters

Connectivity | Process Wiring

MC-HL Receptacle Extensions

Explosion-proof Feed-Thru Y-Fitting

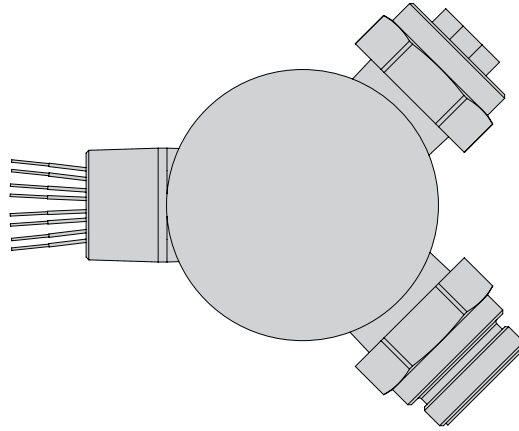

Available Options:
 Male-Male connectors
 Female-Female connectors
 Male-Female connectors (shown)

Typical Field Applications

Daisy Chain Wiring

Class I, Division 2

Explosion-proof Instrument

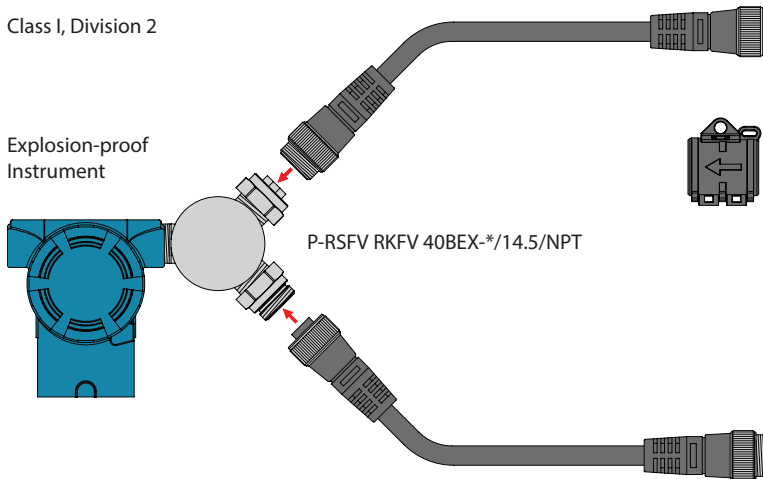

LOCK-MINI for each
 7/8-16 UN Minifast
 connector (four needed)

Wiring Two Sensors Into One Entry

Class I, Division 2

Explosion-proof Instrument

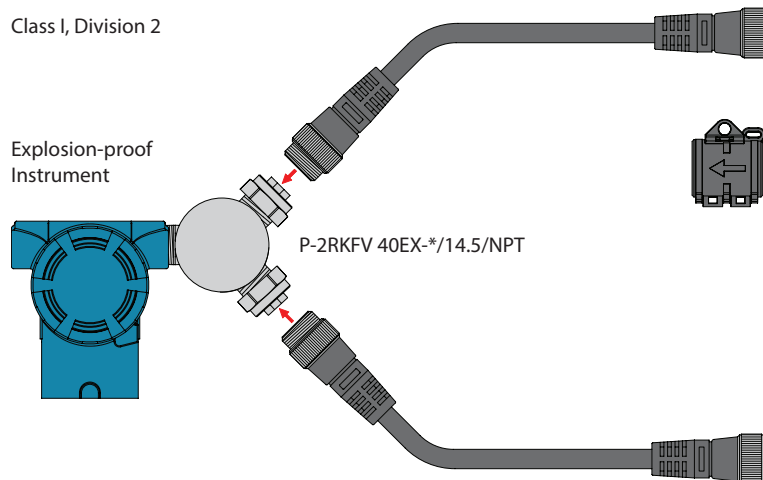

LOCK-MINI for each
 7/8-16 UN Minifast
 connector (four needed)

* = length in meters

We reserve the right to make technical alterations without prior notice.

Connectivity | Process Wiring

Accessories

Field Wirable Connector - Minifast

Housing Style	Part Number	Features	Pinout
	BS 4140-0/9	Glass filled nylon, PG 9 cable gland, accepts 6-8 mm cable diameter, 90 °C, 250 V, 9 A, mates with all 4-pin Minifast cordsets and receptacles	
	BSV 4140-0/9	Glass filled nylon, stainless steel coupling nut, PG 9 cable gland accepts 6-8 mm cable diameter, 90 °C, 250 V, 9 A, mates with all 4-pin Minifast cordsets and receptacles	

Closure Caps

Connector Style	Part Number	Features
	RKMV-CC	Stainless steel, 7/8-16 UN threads, 6" stainless steel lanyard, closure cap, mates to male cordsets, receptacles
	RSMV-CC	Stainless steel, 7/8-16 UN threads, 6" stainless steel lanyard, closure cap, mates to female cordsets, receptacles
	RSFV-CC	Stainless steel, 7/8-16 UN threads, 6" stainless steel lanyard, closure cap, mates to female cordsets, receptacles



M23 Multifast

Connector Style	Part Number	Features
	CS-CC	Nickel plated brass Neoprene gasket, closure caps for Multifast cordset connectors

Connectivity | Process Wiring

Accessories

Junction Box Mounting Kits

	Part Number	Features
	KIT, J-BOX MOUNTING, 4-PORT METAL	Galvanized steel mounting bracket for 4-port junction boxes. Includes mounting hardware. U-bolt fits up to 2 1/2" outside diameter pipe.
	KIT, J-BOX MOUNTING, 8-PORT METAL	Galvanized steel mounting bracket for 8-port junction boxes. Includes mounting hardware. U-bolt fits up to 2 1/2" outside diameter pipe.



WARRANTY TERMS AND CONDITIONS

RISK OF LOSS

Delivery of the equipment to a common carrier shall constitute delivery to the Purchaser and the risk of loss shall transfer at that time to Purchaser. Should delivery be delayed due to an act or omission on the part of the Purchaser, risk of loss shall transfer to the Purchaser upon notification by Turck Inc. that the order is complete and ready for shipment.

WARRANTIES

Turck INC. (hereinafter "Turck") offers five (5) WARRANTIES to cover all products sold. They are as follows:

- 1) The **12-MONTH WARRANTY** is available for the products listed - generally those not covered by **LIFETIME, 5-YEAR, 24-MONTH** or **18-MONTH** warranty. No registration required.
- 2) The **18-MONTH WARRANTY** is available for the products listed - generally those not covered by **LIFETIME** or **5-YEAR WARRANTY**. No registration is required.
- 3) The **24-MONTH WARRANTY** is available for the products listed - generally those not covered by **LIFETIME, 5-YEAR** or **18-MONTH**. No registration is required.
- 4) The **5-YEAR WARRANTY** is available generally for the products listed. No registration is required.
- 5) A **LIFETIME WARRANTY** is available for the products listed. It becomes effective when the accompanying Turck **LIFETIME WARRANTY REGISTRATION** is completed and returned to Turck.

GENERAL TERMS AND CONDITIONS FOR ALL WARRANTIES

- **12-MONTH STANDARD WARRANTY**
- **18-MONTH STANDARD WARRANTY**
- **24-MONTH STANDARD WARRANTY**
- **5-YEAR WARRANTY**
- **LIFETIME WARRANTY**

Turck warrants the Products covered by the respective WARRANTY AGREEMENTS to be free from defects in material and workmanship under normal and proper usage for the respective time periods listed above from the date of shipment from Turck. In addition, certain specific terms apply to the various WARRANTIES.

THESE EXPRESS WARRANTIES ARE IN LIEU OF AND EXCLUDE ALL OTHER REPRESENTATIONS MADE - BOTH EXPRESSED AND IMPLIED. THERE ARE NO WARRANTIES OF MERCHANTABILITY OR OF FITNESS FOR A PARTICULAR PURPOSE FOR PRODUCTS COVERED BY THESE TERMS AND CONDITIONS.

Turck warrants that the goods sold are as described, but no promise, description, affirmation of fact, sample model or representation, oral or written shall be part of an order, unless set forth in these terms and conditions, or are in writing and signed by an authorized representative of Turck. These WARRANTIES do not apply to any Product which has been subject to misuse, negligence, or accident - or to any Product which has been modified or repaired, improperly installed, altered, or disassembled - except according to Turck's written instructions.

These WARRANTIES are subject to the following conditions:

- 1) These WARRANTIES are limited to the electronic and mechanical performance only, as expressly detailed in the Product specifications and NOT to cosmetic performance.
- 2) These WARRANTIES shall not apply to any cables attached to, or integrated with the Product. However, the **18-MONTH WARRANTY** shall apply to cables sold separately by Turck.
- 3) These WARRANTIES shall not apply to any Products which are stored, or utilized, in harsh environmental or electrical conditions outside Turck's written specifications.
- 4) The WARRANTIES are applicable only to Products shipped from Turck subsequent to January 1, 1988.

ADDITIONAL SPECIFIC TERMS FOR:

(12-MONTH STANDARD WARRANTY) for Linear Displacement Transducers, EZ Track, RFID Products, Draw Wire Assemblies and Slip Rings.

(18-MONTH STANDARD WARRANTY) FOR Q-TRACK INDUCTIVE SENSORS, ULTRASONIC SENSORS, FLOW SENSORS, PRESSURE SENSORS, TEMPERATURE SENSORS, INCLINOMETERS, CABLES AND ALL NON-SENSING PRODUCTS SOLD BY TURCK INC. INCLUDING MULTI-SAFE, MULTI-MODUL, MULTI-CART AND RELATED AMPLIFIER PRODUCTS, RELAYS AND TIMERS.

(24-MONTH STANDARD WARRANTY) FOR ENCODERS excluding Draw Wire Assemblies.

5-YEAR WARRANTY FOR INDUCTIVE AND CAPACITIVE PROXIMITY SENSORS: The periods covered for the above WARRANTIES and Products shall be 12 MONTHS, 18-MONTHS, 24-MONTHS and 5-YEARS, respectively, from the date of shipment from Turck.

LIFETIME WARRANTY (OPTIONAL - REGISTRATION REQUIRED) FOR INDUCTIVE, INDUCTIVE MAGNET OPERATED AND CAPACITIVE PROXIMITY SENSORS SOLD TO THE ORIGINAL PURCHASER FOR THE LIFETIME OF THE ORIGINAL APPLICATION.

WARRANTY TERMS AND CONDITIONS

The following terms apply to the LIFETIME WARRANTY in addition to the General Terms:

- 1) This WARRANTY shall be effective only when the LIFETIME WARRANTY REGISTRATION has been completed, signed by the End User and an authorized Turck Representative or Distributor and has been received by Turck no later than six (6) months after installation in the End User’s Plant, or two (2) years from the date product was shipped from Turck, whichever is sooner.
- 2) This warranty is available only to Turck’s authorized Representatives, Distributors and to the Original User. (The term “Original User” means that person, firm, or corporation which first uses the Product on a continuous basis in connection with the operation of a production line, piece of machinery, equipment, or similar device.) In the event the ownership of the product is transferred to a person, firm or corporation other than the Original User, this WARRANTY shall terminate.
- 3) This WARRANTY is applicable only to the Original Application. In the event the machinery, equipment, or production line to which the Product is connected, or on which it is installed, is substituted, changed, moved or replaced, the WARRANTY shall terminate.
- 4) This WARRANTY shall be valid only if the Product was purchased by the Original User from Turck, or from an authorized Turck Distributor, or was an integral part of a piece of machinery and equipment obtained by the Original user from an Original Equipment Manufacturer, which itself, was purchased directly from Turck or from an authorized Distributor.

PURCHASER’S REMEDIES

This Remedy shall apply to all WARRANTIES. If a Turck Distributor desires to make a WARRANTY Claim, the Distributor shall, if requested by Turck, ship the Product to Turck’s factory in Minneapolis, Minnesota, postage or freight prepaid. If the User desires to make a WARRANTY Claim, they shall notify the authorized Turck Distributor from whom it was purchased or, if such Distributor is unknown, shall notify Turck. Turck shall, at its option, take any of the following two courses of action for any products which Turck determines are defective in materials or workmanship.

- 1) Repair or replace the Product and ship the Product to the Original Purchaser or to the authorized Turck Distributor, postage or freight prepaid; or
- 2) Repay to the Original Purchaser that price paid by the Original Purchaser; provided that if the claim is made under the LIFETIME WARRANTY, and such Product is not then being manufactured by Turck, then the amount to be repaid by Turck to the Original Purchaser shall be reduced according to the following schedule:

<u>Number of Years Since Date of Purchase by Original Purchaser</u>	<u>Percent of Original Purchase Price To Be Paid by Turck</u>
10	50%
15	25%
20	10%
More than 20	5%

PURCHASER’S REMEDIES SHALL BE LIMITED EXCLUSIVELY TO THE RIGHT OF REPLACEMENT, REPAIR OR REPAYMENT AS PROVIDED AND DOES NOT INCLUDE ANY LABOR COST OR REPLACEMENT AT ORIGINAL PURCHASER’S SITE. Turck SHALL NOT BE LIABLE FOR ANY CONSEQUENTIAL DAMAGES RESULTING FROM ANY BREACH OF ANY WARRANTY, EXPRESSED OR IMPLIED, APPLICABLE TO THE PRODUCT, INCLUDING WITHOUT LIMITATION, ANY DAMAGES RESULTING FROM PROPERTY DAMAGE, PERSONAL INJURY OR BUSINESS INTERRUPTION.

CONSIDER SAFETY AND PROTECTION PRECAUTIONS

Turck takes great care to design and build reliable and dependable products, however, some products can fail eventually. You must take precautions to design your equipment to prevent property damage and personal injury in the unlikely event of failure. As a matter of policy, Turck does NOT recommend the installation of electronic controls as the sole device FOR THE PROTECTION OF PERSONNEL in connection with power driven presses, brakes, shears and similar equipment and, therefore, the customer should build in redundancy or dual control using approved safety devices for these applications.

GOVERNING LAW

The sale and purchase of Products covered hereby and all terms and conditions hereof shall be governed by the law of the States of Minnesota.

PROCESS WIRING APPLICATION PRODUCTS

Turck Inc. sells its products through authorized distributors. These distributors provide our customers with technical support, service and local stock. Turck distributors are located nationwide – including all major metropolitan marketing areas.

For application assistance or for the location of your nearest Turck distributor, call:

1-800-544-7769

Specifications in this manual are subject to change without notice. Turck also reserves the right to make modifications and makes no guarantee of the accuracy of the information contained herein.

Literature and media questions or concerns?
Contact Turck USA Marketing – tusa.marketing@turck.com

TURCK



28 subsidiaries and over
60 representations worldwide!

Printed in USA

©2018 by Turck Inc. All rights reserved. No part of the
publication may be reproduced without written permission.

B5111 D 11/18

www.turck.com