



Allen-Bradley

1336 PLUS II Adjustable Frequency AC Drive

AQF05 - AQF75

BRF05 - BRF200

CWF10, CWF20 - CWF200

Troubleshooting Guide

**Rockwell
Automation**

Important User Information

Solid state equipment has operational characteristics differing from those of electromechanical equipment. “*Safety Guidelines for the Application, Installation and Maintenance of Solid State Controls*” (Publication SGI-1.1 available from your local Allen-Bradley Sales Office or online at <http://www.ab.com/manuals/gi>) describes some important differences between solid state equipment and hard-wired electromechanical devices. Because of this difference, and also because of the wide variety of uses for solid state equipment, all persons responsible for applying this equipment must satisfy themselves that each intended application of this equipment is acceptable.

In no event will the Allen-Bradley Company be responsible or liable for indirect or consequential damages resulting from the use or application of this equipment.

The examples and diagrams in this manual are included solely for illustrative purposes. Because of the many variables and requirements associated with any particular installation, the Allen-Bradley Company cannot assume responsibility or liability for actual use based on the examples and diagrams.

No patent liability is assumed by Allen-Bradley Company with respect to use of information, circuits, equipment, or software described in this manual.

Reproduction of the contents of this manual, in whole or in part, without written permission of the Allen-Bradley Company is prohibited.

Throughout this manual we use notes to make you aware of safety considerations.



ATTENTION: Identifies information about practices or circumstances that can lead to personal injury or death, property damage, or economic loss.

Attentions help you:

- identify a hazard
- avoid the hazard
- recognize the consequences

Important: Identifies information that is especially important for successful application and understanding of the product.



Shock Hazard labels may be located on or inside the drive to alert people that dangerous voltage may be present.

SCANport is a trademark of Rockwell Automation.

PLC is a registered trademark of Rockwell Automation.

COLOR-KEYED is a registered trademark of Thomas & Betts Corporation.

IBM is a registered trademark of International Business Machines Corporation.

Windows 95 is a registered trademark of Microsoft Corporation.

Introduction

Manual Objectives

This document is intended as a supplementary addition to the 1336 PLUS 6.1 Troubleshooting Guide. This supplement covers the additional information you will need to help troubleshoot or repair an Allen-Bradley Bulletin 1336 PLUS II Adjustable Frequency AC Drive with A1 - A4 Frames.

Who Should Use This Manual

This manual is intended for qualified service personnel responsible for troubleshooting and repairing the 1336 PLUS II Adjustable Frequency AC Drive. You should:

- Read this entire manual before performing maintenance or repairs to drives.
- Have previous experience with, and basic understanding of, electrical terminology, procedures, required troubleshooting equipment, equipment protection procedures and methods, and safety precautions.



ATTENTION: Some printed circuit boards and drive components may contain hazardous voltage levels. Remove and lock out power before you disconnect or reconnect wires, and before you remove or replace fuses and circuit boards. Verify bus voltage by measuring the voltage between +DC and -DC on Terminal Block TB1. Do not attempt to service the drive until the bus voltage has discharged to zero volts.

ATTENTION: Potentially fatal voltages may result from improper usage of oscilloscope and other test equipment. The oscilloscope chassis may be at a potentially fatal voltage if not properly grounded. If an oscilloscope is used to measure high voltage waveforms, use only a dual channel oscilloscope in the differential mode with X 100 probes. It is recommended that the oscilloscope be used in the A minus B Quasi-differential mode with the oscilloscope chassis correctly grounded to an earth ground.

ATTENTION: Only personnel familiar with the 1336 PLUS II AC Drive and associated machinery should plan or implement the installation, start-up and subsequent maintenance of the system. Failure to comply may result in personal injury and/or equipment damage.

Electrostatic Discharge



ATTENTION: This assembly contains parts and sub-assemblies that are sensitive to electrostatic discharge. Static control precautions are required when servicing this assembly. Component damage may result if you ignore electrostatic discharge control procedures. If you are not familiar with static control procedures, reference Allen-Bradley Publication 8000-4.5.2, Guarding Against Electrostatic Damage, or any other applicable ESD protection handbook.

Electrostatic discharge generated by static electricity can damage the complimentary metallic oxide semiconductor devices on various drive boards. It is recommended that you perform these procedures to guard against this type of damage when circuit boards are removed or installed:

- Wear a wrist-type grounding strap that is grounded to the drive chassis.
- Attach the wrist strap before removing the new circuit board from the conductive packet.
- Remove boards from the drive and immediately insert them into their conductive packets.

1336 PLUS II Product Identification

Drive Nameplate Location - The drive nameplate is located on the the Main Control Board Mounting Plate on B thru G frame drives and on the chassis of A frame drives. The drive nameplate contains the drive's catalog number and other important drive information. Reference the catalog number when ordering replacement parts.

Figure 1.1

Drive Nameplate Location

¹ Refer to page 1-1 for frame reference classifications.

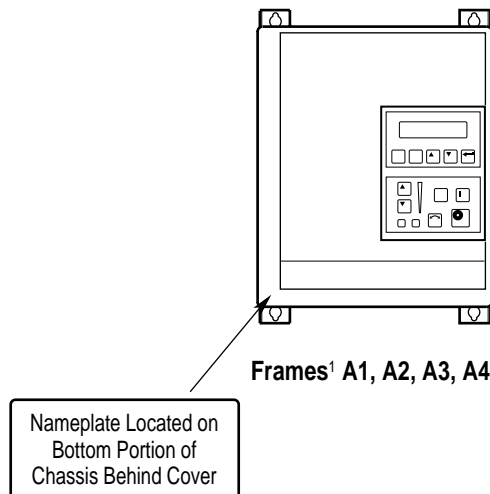

Software Compatibility

Three-Phase Drive Rating ¹			Compatible with Version . . .	Frame Reference
200-240V	380-480V	500-600V		
0.37-0.75 kW 0.5-1 HP	0.37-1.2 kW 0.5-1.5 HP	–	1.0 & Up	A1
1.2-1.5 kW 1.5-2 HP	1.5-2.2 kW 2-3 HP	–	1.0 & Up	A2
2.2-3.7 kW 3-5 HP	3.7 kW 5 HP	–	1.0 & Up	A3
5.5 kW 7.5 HP	5.5-15 kW 7.5-20 HP	0.75-15 kW 1-20 HP	1.0 & Up	A4

1 kW and HP are constant torque.

Drive and Option Identification

The following is an explanation of the catalog numbering system for the PLUS II Adjustable Frequency AC Drives and options. The catalog number is coded to identify the drive power rating and can be found on the drive shipping carton and nameplate.

1336 PLUS II Drive Catalog Numbers

1336F – BR

F30 – AA

– EN – MODS

First Position Bulletin Number	Second Position Voltage	Third Position Nominal HP Rating	Fourth Position Enclosure Type	Fifth Position Language Group ①	Sixth Position Options
	Letter Voltages	Refer to table below for ratings and possible voltage combinations.	Code Type	Code Language	
AQ	200-240V AC or 310V DC		AA IP 20 (NEMA 1)	EN English	
BR	380-480VAC or 513-620V DC		AE IP 20 (NEMA 1)/EMC	FR French	
CW	500-600V AC or 775V DC		AF IP 65 (NEMA 4)③	DE German	
A	200-240V AC		AJ IP 54 (NEMA 12)③	IT Italian	
B	380-480V AC		AN IP 00 (Open)	ES Spanish	
BP/BPR ④	380-480V AC (F Frame)			JP Japanese	
BX	Special Rating				
C	500-600V AC				
CP/CPR ④	500-600V AC (F Frame)				
Q	310V DC				
R	513-620V DC				
RX	Special Rating				
W	775V DC				

Voltage and Nominal HP Rating Combinations

Code	Rating	AQ	BR	CW	A	B	BP/BPR	BX	C	CP/CPR	Q	R	RX	W
F05	0.37 (0.5)	●	●											
F07	0.56 (0.75)	●	●											
F10	0.75 (1)	●	●	●										
F15	1.2 (1.5)	●	●											
F20	1.5 (2)	●	●	●										
F30	2.2 (3)	●	●	●										
F50	3.7 (5)	●	●	●										
F75	5.5 (7.5)	●	●	●										
F100	7.5 (10)		●	●										
F150	11 (15)		●	●										
F200	15 (20)		●	●										
007	5.5 (7.5)				●						●			
010	7.5 (10)				●						●			
015	11 (15)				●	●					●	●		
020	15 (20)				●	●					●	●		
025	18.5 (25)				●	●			●		●	●		●
030	22 (30)				●	●			●		●	●		●
040	30 (40)				●	●		●	●		●	●	●	●
050	37 (50)				●	●		●	●		●	●	●	●
060	45 (60)				●	●		●	●		●	●	●	●
075	56 (75)				●	●		●	●		●	●	●	●
100	75 (100)				●	●		●	●		●	●	●	●
125	93 (125)				●	●		●	●		●	●	●	●
150	112 (150)					●		●	●		●	●	●	●
200	149 (200)					●		●	●		●	●	●	●
250	187 (250) ②					●	●	●	●		●	●	●	●
300	224 (300) ②					●	●	●	●		●	●	●	●
350	261 (350) ②					●	●	●	●	●	●	●	●	●
400	298 (400) ②					●	●	●	●	●	●	●	●	●
450	336 (450) ②					●	●	●	●	●	●	●	●	●
500	373 (500) ②					●	●	●	●	●	●	●	●	●
600	448 (600)					●	●	●	●	●	●	●	●	●

Code	Description
Human Interface Module, Snap-In, IP20 (NEMA Type 1)	
HASB	Snap-In Cradle/Blank Plate
HASP	Programmer Only
HCSP	Programmer Only & Upload/Download Capability
HAS1	Programmer/Controller w/Analog Pot
HCS1	Programmer/Controller w/Analog Pot & Upload/Download Capability
HAS2	Programmer/Controller w/Digital Pot
HCS2	Programmer/Controller w/Digital Pot & Upload/Download Capability
Human Interface Module, IP65/54 (NEMA Type 4/12)	
HJP	Programmer Only
HJ2	Programmer/Controller w/Digital Pot
Communication Options – B Frame & Up (Adapter 6)	
GM1	Single Point Remote I/O B Frame
GM2	RS-232/422/485, DF1 & DH485 B Frame
GM5	DeviceNet™
GM6	Enhanced DeviceNet™
Communication Options – All Frames (Adapter 1)	
GMS1	GM1 with Snap-In Cradle
GMS2	GM2 with Snap-In Cradle
GMS5	GM5 with Snap-In Cradle
GMS6	GM6 with Snap-In Cradle
Control Interface Options	
L4	TTL Contact
L4E	TTL Contact & Encoder Feedback
L7E	TTL Contact & Encoder Fdbck. for use with Encoder Loss Detection
L5	24V AC/DC
L5E	24V AC/DC & Encoder Feedback
L8E	24V AC/DC & Encoder Feedback for use with Encoder Loss Detection
L6	115V AC
L6E	115V AC & Encoder Feedback
L9E	115V AC & Encoder Feedback for use with Encoder Loss Detection
Analog Interface Options – Slot A	
• Choose No More than One – Configurable Inputs/Outputs are 10V or 20mA	
LA2	Two Isolated Configurable Inputs
LA6	One Isolated Bi-polar Input (±10V or ±20mA) and One Isolated Thermistor Input
LA7	One Isolated Bi-polar Input (±10V or ±20mA) and One Isolated Configurable Input
Analog Interface Options – Slot B	
• Choose No More than One – Configurable Inputs/Outputs are 10V or 20mA	
LA1	Single-ended, Non-isolated Configurable (including Pot) Input & 2 Single-ended, Non-isolated Outputs (1 - Configurable, 1 - 20mA)
LA3	Two Isolated Configurable Outputs
LA4	One Isolated Configurable Input & Output
LA5	Isolated Pulse Input, Non-isolated Pulse Output & Single-ended, Non-isolated Configurable Output
Common Mode Choke – F & G Frame (must be specified for F Frame)	
CM	Internal Common Mode Choke (factory installed)
NCM	No Common Mode Choke

① Language must be specified to ensure shipment of appropriate User Manual.
 ② G Frame Standard Drives in enclosed construction are supplied through the *Configured Drives Program* and will have an "A" suffix after the HP rating.
 ③ D through G Frame drives in IP 65 (NEMA Type 4) and IP 54 (NEMA Type 12) configurations are supplied through the *Configured Drives Program*.
 ④ "xPR" has a "roll-in" type chassis.

Drive Rating Qualifications

Several factors can affect drive rating. If more than one factor exists, derating percentages must be multiplied. For example, if a 14-amp drive is installed at a 2km (6,600 ft.) altitude and has a 2% high-input line voltage, the actual amp rating is:

14 x 94% altitude derating x 96% high-input line derating = 12.6 amps.

User Supplied Enclosures

1336 PLUS II drives installed in user supplied enclosures may be mounted within an enclosure or may be mounted to allow the heat sink to extend outside the enclosure. Use the information in the 1336 PLUS II User Manual (1336 PLUS-5.3) to help determine if a possible enclosure sizing or derating problem exists.

Conventions

To help differentiate parameter names and display text in this manual, the following conventions will be used.

- Parameter Names will appear in [brackets].
- Display Text will appear in “quotes”.

The following is a list of conventions used throughout this manual, and definitions of the conventions. For a list of terminology and definitions, refer to the Glossary in the back of this manual.

Auxiliary Input

The Auxiliary Input is a terminal connection on the Control Interface Board. This connection provides an external input for use as an Auxiliary Interlock. Unless this interlock is closed, the drive will be faulted with an AuxiliaryFault.

Auxiliary Interlock

The Auxiliary Interlock is a user supplied circuit consisting of reset, overload, or other interlocking circuitry. The interlock is wired to the drive Auxiliary input.

Bit

A bit is a single character or status point used in programmable logic. Eight bits form a BYTE, 16 bits form a word. Drive parameters are actually eight bits or 16 bit words.

Check

To check means to examine either the physical condition of something or the setting of some control, such as a Parameter. Checking a drive board or component may also require measurements and tests.

Connector

A connector connects one drive board to another. Connectors come in two designs, male and female. Male connectors are stationary and contain pins, which are sometimes joined by jumpers. Female connectors are at the ends of wires or ribbon cables and plug into male connectors.

Default

When a drive defaults, it automatically changes to a pre-programmed setting.

Enable Input

The Enable Input is a terminal connection on the Control Interface Board. This connection provides an external input to enable or disable the Drive Output section. It must be true to permit the drive to operate.

False

False refers to a logical false state. For instance, a Control Interface signal on TB3 is false when the input contact is open or the appropriate voltage is not applied to the Control Interface Board.

Jumper

A jumper completes a circuit between two pins within a male connector on a drive board. In the absence of certain optional equipment using female connectors, jumpers are applied to certain pins within a male connector to complete specific and necessary circuits.

Control Interface Board

A Control Interface Board plugs into connectors J2 & J4, located on the lower portion of the Main Control Board. This board is identified as L4/4E, L5/L5E, L6/L6E, L7E, L8E or L9E and provides optional control wiring configurations for a drive Control Interface Board.

Parameter

Parameters are programmable drive functions that define various operating functions or status displays of a drive. Refer to Bulletin 1336 PLUSII User Manual (1336 PLUS-5.3) for Parameter details.

Press

Press a button on the Human Interface Module to change Parameter settings and drive functions.

True

True refers to a logical true state. For example, a Control Interface signal on TB3 is true when: L4/L4E contact input is closed, L8E input terminal registers 24V, or L9E input terminal registers 115 VAC.

Control Logic Wiring and Adapters

Chapter Objectives

This chapter introduces you to terminal block locations and wiring and adapter locations and functions.

Chapter Overview

This chapter illustrates and describes:

- Control Logic Interface Options L4, L5, L6, L7, L8 and L9 including terminal block TB3.
- TB3 terminal designations.
- TB3 input mode selections and functions.

All printed circuit boards, except the Main Control Board assembly, are referenced to negative ground (-bus).



ATTENTION: Some printed circuit boards and drive components may contain hazardous voltage levels. Remove and lock out power before you disconnect or reconnect wires, and before you remove or replace fuses and circuit boards. Verify bus voltage by measuring the voltage between +DC and -DC on Terminal Block TB1. Do not attempt to service the drive until the bus voltage has discharged to zero volts.

ATTENTION: This assembly contains parts and sub-assemblies that are sensitive to electrostatic discharge. Static control precautions are required when servicing this assembly. Component damage may result if you ignore electrostatic discharge control procedures. If you are not familiar with static control procedures, reference Allen-Bradley Publication 8000-4.5.2, Guarding Against Electrostatic Discharge, or any other applicable ESD protection handbook.

Figure 2.1 Terminal Block Locations

- TB1 Power Terminal Block
- TB2 Control & Signal Wiring
- TB3 Control Interface Option
- TE Control & Signal Shield Terminals

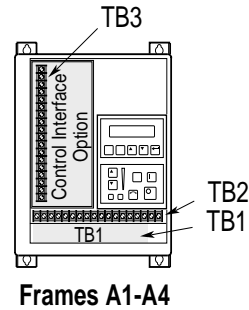

ATTENTION: The National Electrical Code (NEC) and local codes outline provisions for safely installing electrical equipment. Installation must comply with specifications regarding wire types, conductor sizes, branch circuit protection and disconnect devices. Failure to do so may result in personal injury and/or equipment damage.

Control Interface Option

The Control Interface Option provides a means of interfacing various signals and commands to the 1336 PLUS II by using contact closures.

Nine different versions of the option are available:

- L4 Contact Closure Interface ¹
- L4E Contact Closure Interface with Encoder Feedback Inputs ¹
- L5 24V AC/DC
- L5E 24V AC/DC & Encoder Feedback
- L6 115V AC
- L6E 115V AC & Encoder Feedback
- L7E TTL Contact & Encoder Fdback for use with Encoder Loss Detection
- L8E 24V AC/DC & Encoder Fdback for use with Encoder Loss Detection
- L9E 115V AC & Encoder Feedback for use with Encoder Loss Detection

¹ Uses internal +5V DC supply.

The user inputs are connected to the option board through TB3. The L4 thru L9 options each have nine control options. The function of each input must be selected through programming as explained later in this chapter. The L4E, L5E and L6E options are similar to L4, L5 and L6 with the addition of encoder feedback inputs.

Control Interface Board Jumpers

IMPORTANT: If the Control Interface Board is being installed, Main Control Board Jumpers at pins 3 & 4 and 17 & 18 of J2 must be removed and the proper [Input Mode] selected. If this board is removed, these jumpers must be reinstalled and the [Input Mode] parameter must be programmed to “Status (1).”

Figure 2.2 Jumper Locations

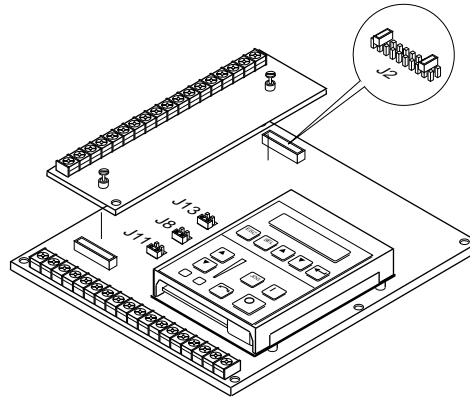

Frames¹ A1 - A4

¹ Refer to page 1-1 for frame reference classifications.

Digital Inputs

Digital Inputs are connected at TB3.

Input Mode Select

A number of combinations are available by first programming [Input Mode] to the desired control scheme (i.e. 2 wire, 3 wire or Status). The remaining inputs can then be configured by programming [TB3 Term 22 Sel] through [TB3 Term 28 Sel]. Refer to the Digital I/O parameter group in Chapter 6 of the PLUS II User Manual for programming information.

Figure 2.3 Digital I/O Default Settings - TB3.

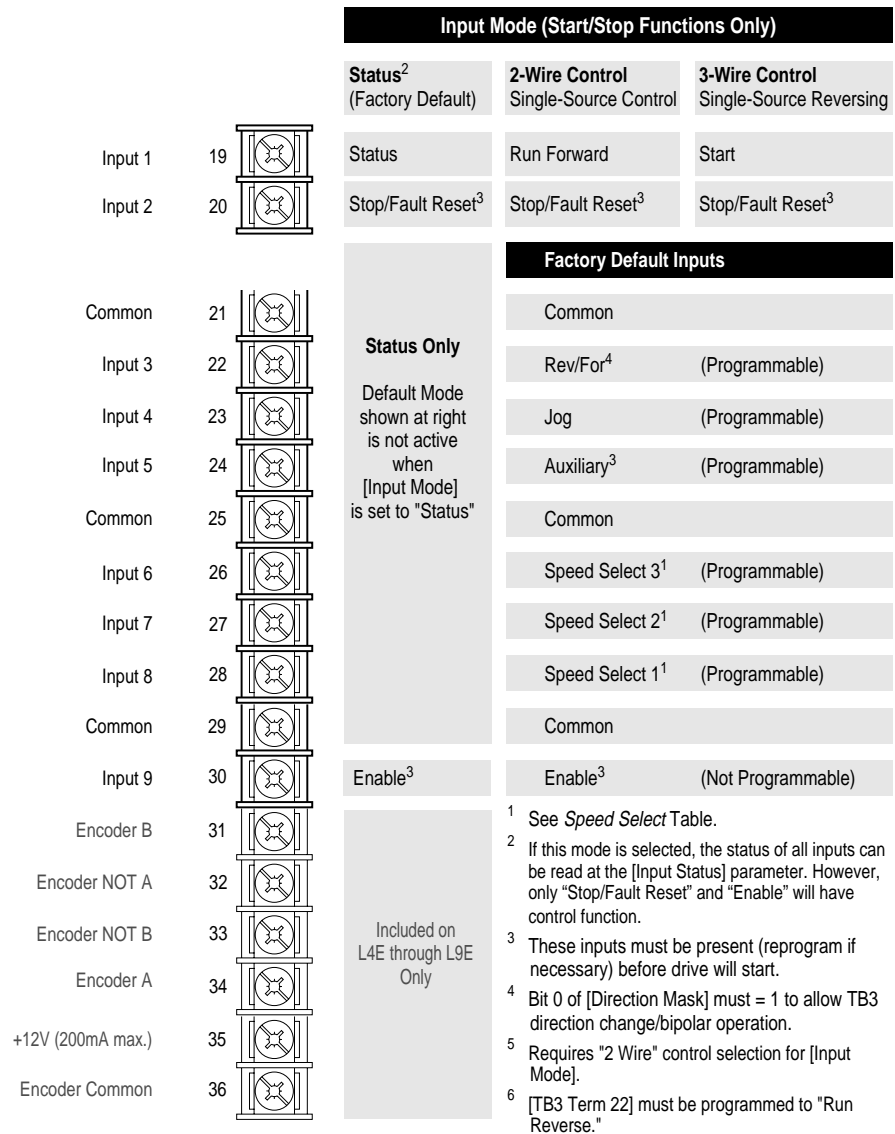

2-Wire Control Example

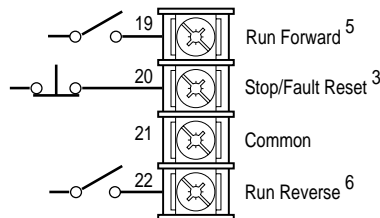

3-Wire Control Example

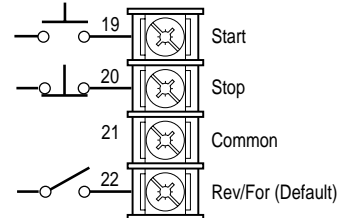

A hazard of personal injury from automatic restart exists with 2-wire control. 2-wire control uses maintained Run contacts that act as both Run (closed) and Stop (open) devices. Opening the Stop contact (terminal 20) will stop the drive. If this contact is reclosed, any fault will be reset. If a valid Start command is still present, the drive will restart. Only use 2-wire control for applications outlined in NFPA79, "Under Voltage Protection."

If a 3-wire device (i.e. HIM) is also used, pressing the HIM Stop key will also stop the drive. Releasing the Stop key will clear any faults that are present, but the drive will not restart without cycling the Start contact.

The following table defines the input state of the Speed Select inputs for a desired frequency source.

Table 2.A Speed Select Input State vs. Frequency Source.

Speed Select 3	Speed Select 2	Speed Select 1	Frequency Source
Open	Open	Open	[Freq Select 1]
Open	Open	Closed	[Freq Select 2]
Accessed through [Freq Select 2] parameter			[Preset Freq 1]
Open	Closed	Open	[Preset Freq 2]
Open	Closed	Closed	[Preset Freq 3]
Closed	Open	Open	[Preset Freq 4]
Closed	Open	Closed	[Preset Freq 5]
Closed	Closed	Open	[Preset Freq 6]
Closed	Closed	Closed	[Preset Freq 7]

Local Programming

For local programming and control information, refer to the 1336 PLUS II User Manual.

Human Interface Module

For a complete description of the Human Interface Module (HIM) including key descriptions, module removal and overall HIM operation refer to Chapter 3 of the 1336 PLUS II User manual (1336 PLUS 5.3).

This Page Intentionally Blank

Troubleshooting and Error Codes

Chapter Objectives

This chapter helps you trace faults to field-replaceable components.

NOTE: On 1336 PLUS II A1 - A4 Frames, the only replaceable parts are the Main Control Board and Fans.

Troubleshooting Overview

To troubleshoot a 1336 PLUS II Adjustable Frequency AC Drive, you need a Range DVM, or VOM with a range capacity of at least 1000V.

IMPORTANT: All printed circuit boards, except the Main Control Board assembly, are referenced to negative ground (-bus).



ATTENTION: Power circuits are optically isolated from control driver circuits. Power circuit components are “floating” with respect to “ground”. Use only approved methods of isolating test equipment when making measurements in power circuits.

ATTENTION: Some printed circuit boards and drive components may contain hazardous voltage levels. Remove power before you disconnect or reconnect wires, and before you remove or replace fuses and circuit boards. Verify bus voltage by measuring the voltage between +DC and -DC on Terminal Block TB1. Do Not attempt to service the drive until the bus voltage has discharged to zero volts.

ATTENTION: Potentially fatal voltages may result from improper usage of oscilloscope and other test equipment. The oscilloscope chassis may be at a potentially fatal voltage if not properly grounded. We do not recommend use of an oscilloscope to directly measure high voltages. Use an isolated measuring device with a high voltage probe. Contact Allen-Bradley for recommendations.

ATTENTION: To guard against equipment damage when troubleshooting the drive, always check the following before issuing a Start command:

- Set the Speed Reference to minimum.
 - Select the proper motor-rotation direction.
 - Disconnect the motor from its mechanical load.
-



ATTENTION: This assembly contains parts and sub-assemblies that are sensitive to electrostatic discharge. Static control precautions are required when servicing this assembly. Component damage may result if you ignore electrostatic discharge control procedures. If you are not familiar with static control procedures, reference Allen-Bradley Publication 8000-4.5.2, Guarding Against Electrostatic Discharge, or any other applicable ESD protection handbook.

Electrostatic Discharge Precautions

Electrostatic Discharge generated by static electricity can damage the complimentary metallic oxide semiconductor devices on various drive boards. It is recommended that you perform these procedures to guard against this type of damage when circuit boards are removed or installed.

- Wear a wrist type grounding strap that is grounded to the chassis.
- Attach the wrist strap before removing the new circuit board from the conductive packet.
- Remove boards from the drive and immediately insert them into their conductive packets.

Fault Descriptions

Fault Display

The LCD display is used to indicate a fault by showing a brief text statement relating to the fault as shown in the following figure. The fault will be displayed until “Clear Faults” is initiated or drive power is cycled. A Series A (version 3.0) or Series B & up HIM will display a fault when it occurs, no matter what state the display is in. In addition, a listing of past faults can be displayed by selecting “Fault queue” from the Control Status menu (See Chapter 3 of the 1336 PLUS II user manual for more information). Refer to Table 3.A for a listing and description of the various faults.

Figure 3.1 Fault Display



Clearing a Fault

When a fault occurs, the cause must be corrected before the fault can be cleared. After corrective action has been taken, simply cycling drive power will clear the fault. Issuing a valid Stop command from the HIM or Control Interface option (TB3) will also clear a fault if the {Flt Clear Mode} parameter is set to “Enabled”. In addition, a “Clear Faults” command can be issued anytime from a serial device (if connected).

Contact Description

A schematic representation of contacts CR1-CR4 is shown in Figure 2-5 of the 1336 PLUS II User Manual. When powered these contacts will change state. For Example: During normal operating conditions (no faults present, drive running), the CR3 contacts (default firmware setting) at TB2-13 & 14 are open, and the contacts at TB2-14 & 15 are closed. When a fault occurs, the state of these contacts will change.

Table 3.A
1336 PLUS II Fault Descriptions

Name & Fault #	Description	Action
Adptr Freq Err 65	The SCANport adapter that was the selected frequency reference sent a frequency greater than 32767 to the drive.	Correct the problem that is causing the SCANport adapter to send the illegal frequency reference to the drive.
Auxiliary Fault 02	The auxiliary input interlock is open.	If Control Interface option is installed, check TB3 connections. If not installed, set [Input Mode] to "Status."
Bgnd 10ms Over 51	Microprocessor loop fault. Occurs if the 10ms background task hasn't been run in 15 ms.	Replace Main Control Board or complete drive as required.
Bipolar Dir Flt 16	3 Wire – Bi-polar input is the active frequency reference and direction control is not possible. 2 Wire – Run Forward or Reverse commands attempt direction control, but bi-polar input is not masked from direction control.	a) Mask out direction control at bit 7 of [Direction Mask]. b) Remove or mask other direction control sources. Set bit 7 of [Direction Mask] to zero.
Blwn Fuse Flt 58	If the difference between the commanded voltage and the measured voltage is greater than 1/8 of rated voltage for 0.5 seconds, then a fault will be issued indicating that the bus fuse in 30 kW (40HP) & up drives has blown.	Locate cause, replace fuse.
C167 Watchdog 17	Internal microprocessor fault.	If there is only one occurrence, reset the fault and continue. If the fault continuously or frequently reoccurs, contact your local service representative or replace the Main Control Board.
Diag C Lim Flt 36	The drive output current has exceeded the hardware current limit and the [Cur Lim Trip En] parameter was enabled.	Check [Cur Lim Trip En]. Check for excess load, improper DC boost setting, DC brake volts set too high or other causes of excess current.
Drive -> HIM	Refer to Table 3B.	
DSP Checksum 37	There was a breakdown in communications between the DSP and main processors.	Reset to factory defaults. Replace Main Control Board or Gate Driver Board.
DSP Comm Fault 27	Refer to the "Description" and "Action" statements for C167 Watchdog (F17) above.	
DSP Protected 46	Flash download included a new DSP Main Block and J14 was not installed when power was restored.	Remove power from the drive. Install J14 per download kit instructions and reapply power. When transfer is complete, remove power and J14.
DSP Queue Fault 31	Refer to the "Description" and "Action" statements for C167 Watchdog (F17) above.	

Name & Fault #	Description	Action
DSP Reset Fault 22	Power-up has been attempted with an Open Stop contact or Closed Start contact.	Check/verify wiring and contact operation.
DSP Timeout Fault 28	Refer to the "Description" and "Action" statements for C167 Watchdog (F17) on page 3.3.	
EE Init Read 53	<ol style="list-style-type: none"> Gate Drive Bd. replacement (requires re-initialization). Trouble reading EEPROM during initialization. 	<ol style="list-style-type: none"> Reset to factory defaults & cycle input power. Check all connections to Power/Driver Board. Replace board or complete drive as needed.
EE Init Value 54	Stored parameter value out of range on initialization.	<ol style="list-style-type: none"> Reset to factory defaults & cycle input power. Check all connections to the Power/Driver Bd. Replace the board or complete drive as needed.
EEprom Checksum 66	The checksum read from the EEPROM does not match the checksum calculated from the EEPROM data.	<ol style="list-style-type: none"> Reset to factory defaults & cycle input power. Check all wire and cable connections to the Power Driver Board. Replace Power Driver Board or complete drive as required.
EEprom Fault 32	EEPROM is being programmed and will not write a new value.	Check all wire and cable connections to the Main Control Board. Replace Main Control Board or complete drive as required.
Encoder Loss 60	<p>The drive has detected an error in the encoder signals at TB3, terminals 31-36. The error could be due to a:</p> <ol style="list-style-type: none"> Loss of 1 or more channels. Loss of quadrature. Loss of differential signal (A & A NOT or B & B NOT were high at the same time). 	Check encoder and wiring.
Fgnd 10ms Over 52	Microprocessor loop fault. Occurs if a 10ms interrupt is pending before the current interrupt is complete.	Replace Main Control Board or complete drive as required.
Ground Fault 13	A current path to earth ground in excess of 100A has been detected at one or more of the drive output terminals. NOTE: If ground current exceeds 220% of drive rated current, "Overcurrent Flt" may occur instead of Ground Fault.	Check the motor and external wiring to the drive output terminals for a grounded condition.
Ground Warning 57	A current path to earth ground in excess of 2A has been detected at one or more of the drive output terminals. See [Ground Warning].	Check the motor and external wiring to the drive output terminals for a grounded condition.
Hardware Trap 18	Refer to the "Description" and "Action" statements for C167 Watchdog (F17) on page 3.3.	

Name & Fault #	Description	Action
Hertz Err Fault 29	This fault indicates that there is not a valid operating frequency. It can be caused by any of the following: 1. [Maximum Freq] is less than [Minimum Freq]. 2. Skip frequencies and skip bandwidth eliminate all operating frequencies. 3. Analog input signal speed reference has been lost. See [Anlg Signal Loss] and [4-20mA Loss Sel].	1. Check [Minimum Freq] and [Maximum Freq] parameters. 2. Check [Skip Freq 1], [Skip Freq 2], [Skip Freq 3] and [Skip Freq Band] parameters. 3. Check for broken wires, loose connections or transducer loss at analog inputs.
Hertz Sel Fault 30	A frequency select parameter has been programmed with an out of range value.	Reprogram [Freq Select 1] and/or [Freq Select 2] with a correct value. If problem persists, replace Main Control Board or complete drive.
HIM -> Drive	Refer to Table 3.B.	
Ill Prog Input 62	[Fault Data] = 98 – “3 Wire” is selected as the [Input Mode] and one or more digital inputs are programmed to “Run Reverse” (2 wire action).	Reprogram the digital inputs or select “2 Wire” as the [Input Mode].
Input Phase Flt 49	The DC bus ripple has exceeded the value in [Phase Loss Level].	1. If the drive is operated on single-phase, the load derating level has been exceeded. 2. Check incoming power for a missing phase/blown fuse.
Load Loss Flt 20	[Load Loss Detect] is set to “Enabled” and the drive output torque current was below [Load Loss Level] for a time period greater than [Load Loss time].	1. Verify connections between motor and load. 2. Verify level and time requirements or disable [Load Loss Detect].
Loop Overrn Flt 23	An overrun of the 2.5ms control loop has occurred.	Check all connections to the Main Control Board. Replace the board or complete drive as needed.
Max Retries Fault 33	Drive unsuccessfully attempted to reset a fault and resume running for the programmed number of [Reset/Run Tries].	Check fault buffer for fault code requiring reset. Correct the cause of the fault and manually clear by pressing the local Stop key or cycling the TB3 Stop input.
Motor Mode Flt 24	A fault has been detected originating from the Control Board.	Check all connections to the Control Board. Replace the board or complete drive as required.
Motor Stall Fault 06	Current remained over [Current Limit] setting (parameter 36) for more than 4 seconds.	If the motor is drawing excessive current (over [Current Limit] setting), the motor load is excessive and will not allow the drive to accelerate to set speed. A longer accel time or a reduced load may be required.
Motor Thermistor 15	An analog option board with thermistor input is installed and the value at the terminals is less than 60 ohms or greater than 3300 ohms.	1. Verify that thermistor is connected. 2. Motor is overheated. Reduce load. 3. Thermistor is not present. Remove option board.

Name & Fault #	Description	Action
Mult Prog Input 61	A single source input function such as Reverse/Forward (open=1 st function, closed=2 nd function) has been programmed to more than one input or more than one "Run Reverse" input.	Reprogram one or more of the inputs to a different value.
Neg Slope Fault 35	Drive software detected a portion of the volts/hertz curve with a negative slope.	Check drive programming. 1. [Base Voltage] parameter must be greater than [Start Boost]. 2. If the [DC Boost Select] parameter is set to "Full Custom," [Base Voltage] must be greater than [Break Voltage] and [Break Voltage] must be greater than [Start Boost].
Open Pot Fault 09	An external pot is connected and the common side of the pot is open. The drive generates this fault when the voltage between pot leads is greater than 3.9V DC.	Check the external potentiometer circuit at TB2 for an open circuit.
Op Error Fault 11	A SCANport device requests a Read or Write of a data type not supported. This will also occur if: 1. [Motor Type] is set to "Sync PM" and [Stop Mode Used] is set to "DC Brake", or 2. [Motor Type] is set to "Sync Reluc" or "Sync PM" and [Speed Control] is set to "Slip Comp".	Check programming.
Option Error 14	A slot A analog option board has been installed in slot B or A slot B board has been installed in slot A	Remove or relocate to proper slot.
Overcurrent Flt 12	Overcurrent is detected in instantaneous overcurrent trip circuit.	Check for a short circuit at the drive output or excessive load conditions at the motor.
Overload Fault 07	Internal electronic overload trip.	An excessive motor load exists. It must be reduced such that drive output current does not exceed the current set by the [Overload Amps] parameter.
Overspeed Fault 25	Not functional at time of printing.	
Overtemp Fault 08	Heat sink temperature exceeds a predefined value of 90° C (195° F).	Check for blocked or dirty heat sink fins. Check that the ambient temperature has not exceeded 40° C (104° F). Check fan.
Overvolt Fault 05	DC bus voltage exceeded maximum value.	Monitor the AC line for high line voltage or transient conditions. Bus overvoltage can also be caused by motor regeneration. Extend the decel time or install dynamic brake option.
Phase U Fault 38	A phase to ground fault has been detected between the drive and motor in this phase.	Check the wiring between the drive and motor. Check motor for grounded phase.
Phase V Fault 39	A phase to ground fault has been detected between the drive and motor in this phase.	Check the wiring between the drive and motor. Check motor for grounded phase.

Name & Fault #	Description	Action
Phase W Fault 40	A phase to ground fault has been detected between the drive and motor in this phase.	Check the wiring between the drive and motor. Check motor for grounded phase.
Poles Calc Flt 50	Generated if the calculated value of [Motor Poles] is less than 2 or greater than 32.	Check [Motor NP RPM] and [Motor NP Hertz] programming.
Power Loss Fault 03	DC bus voltage remained below 85% of nominal for longer than 500ms. [Line Loss Fault] parameter is set to "enabled."	Monitor the incoming AC line for low voltage or line power interruption.
Power Mode Fault 26	The internal power mode variable received an incorrect value.	Check all connections to the Control Board. Replace the board or complete drive as required.
Power Overload 64	The drive rating of 150% for 1 minute has been exceeded.	Reduce load.
Precharge Fault 19	The precharge device was open 20ms after the end of a line loss condition or the bus charging alarm remains on for 20 seconds (pre-charge did not complete).	See Chapter 1 for frame definitions. <ol style="list-style-type: none"> 1. Frames A1, A2, A3 - Check the pre-charge circuit. Replace the drive. 2. Frame B - Check the precharge circuit. Replace the Power Driver Bd. or complete drive as required. 3. All larger frames - Check the pre-charge circuit. Replace the input SCRs, SCR Firing Board, Power Driver Board or complete drive as needed.
Precharge Open 56	The precharge circuit was commanded to close, but was detected to be open.	See page 1–1 for frame definitions. <ol style="list-style-type: none"> 1. Frames A1, A2, A3 - Check the pre-charge circuit. Replace the drive. 2. Frame B - Check the precharge circuit. Replace the Power Driver Bd. or complete drive as required. 3. All larger frames - Check the pre-charge circuit. Replace the input SCRs, SCR Firing Board, Power Driver Board or complete drive as needed.
Prm Access Flt 34	A communication error occurred between the microprocessor and the serial EEPROM or the DSP.	Record the value in [Fault Data], then reset the fault. If this fault occurs repeatedly, contact factory.
Reprogram Fault 48	The drive was commanded to write default values to EEPROM.	<ol style="list-style-type: none"> 1. Clear the fault or cycle power to the drive. 2. Program the drive parameters as needed. <p>Important: If [Input Mode] has been changed from its original value, power must be cycled before the new value will take affect.</p>
ROM or RAM Flt 68	Internal power-up ROM or RAM tests have not executed properly.	Replace Control Board or complete drive as required.

Name & Fault #	Description	Action
Serial Fault 10	A SCANport adapter has been disconnected and the [Logic Mask] bit for that adapter is set to "1."	<ol style="list-style-type: none"> 1. If no adapter was intentionally disconnected, check wiring to the SCANport adapters. Replace wiring, SCANport expander, SCANport adapters, Main Control Board or complete drive as required. 2. If an adapter was intentionally disconnected and the [Logic Mask] bit for that adapter is set to "1", this fault will occur. To guard against this fault occurring, set the [Logic Mask] bit for the adapter to "0." 3. Check HIM connection for proper seating.
Shear Pin Fault 63	Programmed [Current Limit] amps has been exceeded and [Shear Pin Fault] is enabled.	Check load requirements and [Current Limit] setting.
Sync Loss Fault 67	<i>Not functional at time of printing.</i>	
Temp Sense Open 55	Heat sink thermistor is open or malfunctioning.	Check thermistor and connections.
Undervolt Fault 04	DC Bus voltage fell below the minimum value (388V DC at 460V AC input). [Line Loss Fault] and [Low Bus Fault] set to "enabled."	Monitor the incoming AC line for low voltage or line power interruption.
UV Short Fault 41	Excessive current has been detected between these two output terminals.	Check the motor and external wiring to the drive output terminals for a shorted condition.
UW Short Fault 42	Excessive current has been detected between these two output terminals.	Check the motor and external wiring to the drive output terminals for a shorted condition.
VW Short Fault 43	Excessive current has been detected between these two output terminals.	Check the motor and external wiring to the drive output terminals for a shorted condition.

**Table 3.B
HIM Upload/Download Errors**

Fault Name	Error Displayed	Probable Cause	Action
HIM -> Drive	ERROR 1	The HIM calculated a checksum for the file to be downloaded, then checked the EEPROM checksum of the download. The checksums did not match, indicating the file stored in the HIM is invalid and the download was not successful.	Upload a valid, uncorrupted file from the source drive and then repeat the download.
	ERROR 2	The number of parameters in the HIM file is different than the number of parameters in the drive file. The smaller of the two numbers is the number of parameters downloaded. The last downloaded parameter number is displayed.	Verify that the correct file is being downloaded to the correct drive, then press the Enter key. Manually reprogram the parameters whose numbers are higher than the last number downloaded or whose values were incorrect.
	ERROR 3	The file in the HIM is for a different type of drive than the drive to which it is connected (i.e. 1336 PLUS file to 1336 IMPACT drive). Downloads can only occur between like drive types.	None - Download not allowed.
	ERROR 4	The value just transferred to the drive is an illegal value (out of range, too high or too low) for the parameter.	Record the parameter number displayed and then press the Enter key to continue the download. Manually reprogram all recorded parameters after the download is complete.
	ERROR 5	The download was attempted while the drive was running.	Stop the drive and repeat the download attempt.
	ERROR 6	The file in the HIM is for a different HP or voltage drive than the drive to which it is connected (i.e. 1336 PLUS 10 HP file to 1336 PLUS 15 HP drive).	If the download is desired, press the Enter key. If not desired, press the ESCape key to end the download
Drive -> HIM	ERROR 1	The HIM calculated a checksum as the file was uploaded and compared it to the HIM file checksum stored after the upload. The checksums did not match, indicating the upload was not successful and the HIM file is now corrupted.	Repeat the Upload.

Table 3.C
Fault Code Cross Reference

Fault #	Display Name	Reset/Run
02	Auxiliary Fault	Yes
03	Power Loss Fault	Yes
04	Undervolt Fault	Yes
05	Overvolt Fault	Yes
06	Motor Stall Fault	Yes
07	Overload Fault	Yes
08	Overtemp Fault	Yes
09	Open Pot Fault	No
10	Serial Fault	No
11	Op Error Fault	No
12	Overcurrent Flt	Yes
13	Ground Fault	No
14	Option Error	No
15	Motor Thermistor	No
16	Bipolar Dir Flt	No
17	C167 Watchdog	No
18	Hardware Trap	No
19	Precharge Fault	No
20	Load Loss Flt	No
22	DSP Reset Fault	Yes
23	Loop Overrn Flt	Yes
24	Motor Mode Flt	Yes
26	Power Mode Fault	Yes
27	DSP Comm Fault	No
28	DSP Timeout Fault	No
29	Hertz Err Fault	No
30	Hertz Sel Fault	No
31	DSP Queue Fault	No
32	EEPROM Fault	No
33	Max Retries Fault	No
34	Prm Access Flt	No
35	Neg Slope Fault	No
36	Diag C Lim Flt	No
37	DSP Checksum	No
38	Phase U Fault	No
39	Phase V Fault	No
40	Phase W Fault	No
41	UV Short Fault	No
42	UW Short Fault	No
43	VW Short Fault	No
46	DSP Protected	No
47	Xsistr Desat Flt	No
48	Reprogram Fault	No
49	Input Phase Flt	No
50	Poles Calc Fault	No
51	Bgnd 10ms Over	Yes
52	Fgnd 10ms Over	Yes
53	EE Init Read	No
54	EE Init Value	No
55	Temp Sense Open	No

Fault #	Display Name	Reset/Run
56	Precharge Open	No
57	Ground Warning	No
58	Blwn Fuse Flt	No
60	Encoder Loss	No
61	Mult Prog Input	No
62	Ill Prog Input	No
63	Shear Pin Fault	No
64	Power Overload	No
65	Adptr Freq Err	No
66	EEPROM Checksum	No
67	Sync Loss Fault	No
68	ROM or RAM Flt	No

Note: Fault Numbers not listed are reserved for future use.

Diagnostic Procedures by Symptom

These charts list drive symptoms, symptom descriptions, and recommended actions to remedy the symptoms.

Drive Will Not Start

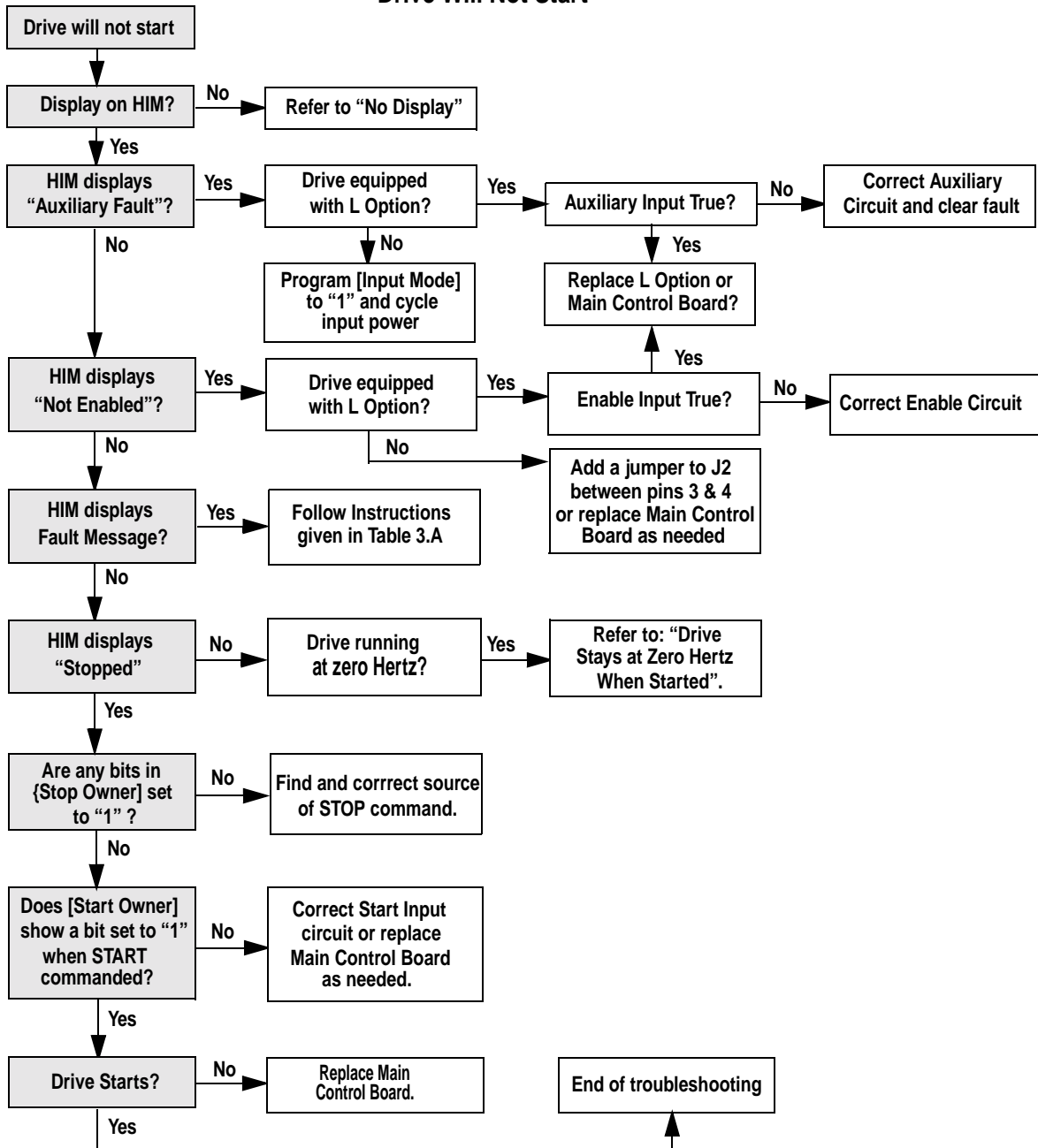

No Display

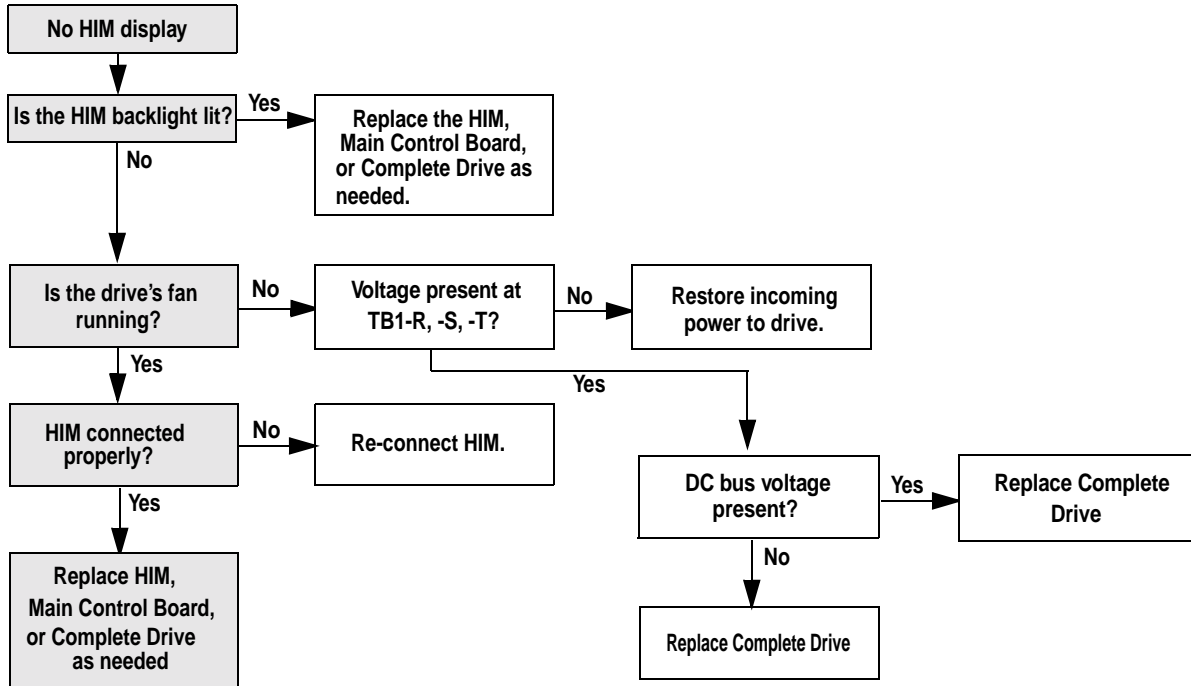

Drive Will Not Jog

Local Human Interface Module used to control drive.

Jog is not active if a START command is present. START command always overrides a JOG command.

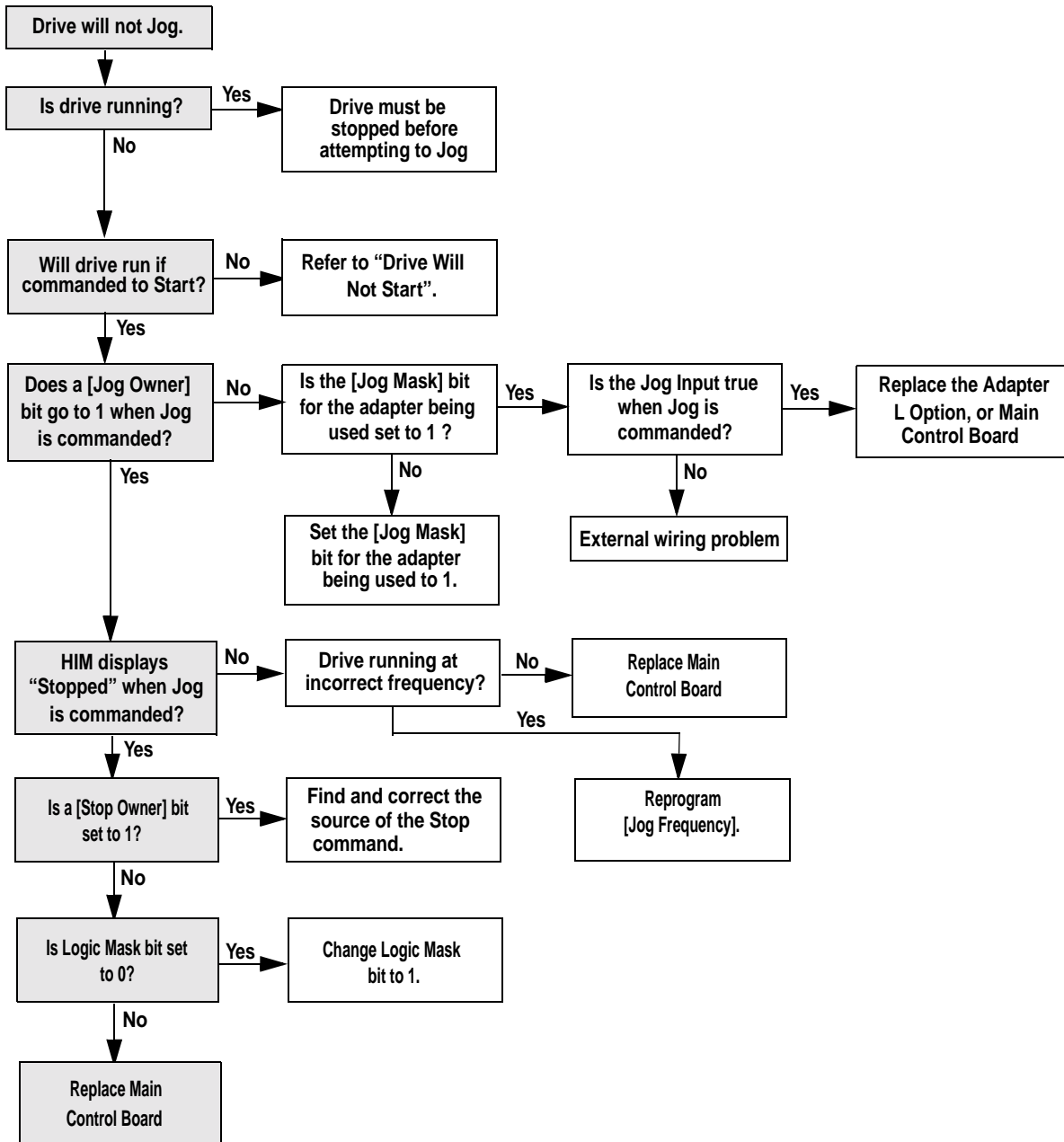

Drive Stays at Zero Hertz When Started

IMPORTANT: [Command Frequency] parameter in the Metering Group can be checked using the HIM.

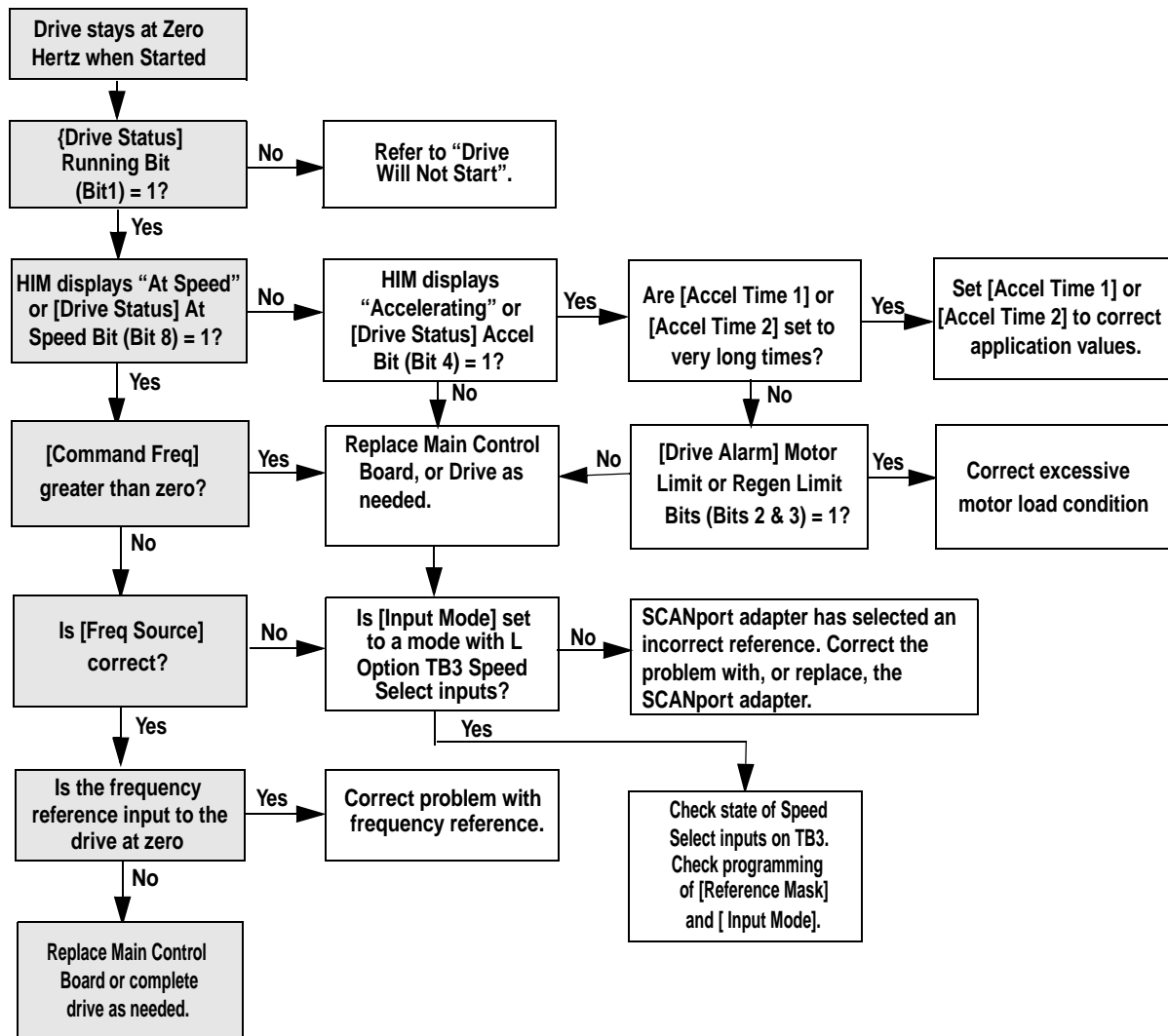

Disassembly and Access Procedures

Chapter Objectives

This chapter describes general disassembly procedures required to remove the Control Interface Board and Main Control Board on A1 to A4 frame drives. Fan replacement is also detailed for A4 frame drives.

Disassembly and Access Overview



ATTENTION: Some printed circuit boards and drive components may contain hazardous voltage levels. Remove and lock out power before you disconnect or reconnect wires, and before you remove or replace fuses and circuit boards. Verify bus voltage by measuring the voltage between +DC and -DC on Terminal Block TB1. Do not attempt to service the drive until the bus voltage has discharged to zero volts.

ATTENTION: Servicing energized industrial control equipment can be hazardous. Electrical shock, burns, or unintentional actuation of controlled industrial equipment may cause death or serious injury. Follow the safety-related practices of NFPA 70E, Electrical Safety for Employee Workplaces, when working on or near energized equipment. Do not work alone on energized equipment.

Electrostatic Discharge Precautions



ATTENTION: This assembly contains parts and sub-assemblies that are sensitive to electrostatic discharge. Static control precautions are required when servicing this assembly. Component damage may result if you ignore electrostatic discharge control procedures. If you are not familiar with static control procedures, reference Allen-Bradley Publication 8000-4.5.2, Guarding Against Electrostatic Discharge, or any other applicable ESD protection handbook.

Electrostatic Discharge generated by static electricity can damage the complimentary metallic oxide semiconductor devices on various drive boards. It is recommended that you perform these procedures to guard against this type of damage when circuit boards are removed or installed.

- Wear a wrist type grounding strap that is grounded to the chassis.
- Attach the wrist strap before removing the new circuit board from the conductive packet.
- Remove boards from the drive and immediately insert them into their conductive packets.

Tools

You need the following tools to disassemble and assemble the drive:

- Pliers
- #2 Phillips and a magnetic flat blade screwdriver
- 5/16 - inch or 8mm socket.
- Torque wrench, metered in lb-in. or N-m

Disassembly and Access Procedures

Drive Enclosure Removal & Installation



ATTENTION: Disconnect and lock out power from the drive before disassembling the drive. Failure to disconnect power may result in death or serious injury. Verify bus voltage by measuring the voltage between +DC and -DC on Terminal Block TB1. Do not attempt to service the drive until the bus voltage has discharged to zero volts.



ATTENTION: Wear a wrist type grounding strap when servicing 1336 PLUS II Drives. Failure to protect drive components against ESD may damage drive components. Refer to Electrostatic Discharge Precautions at the beginning of this chapter.

Removal

Figure 4.1
Removing the Drive Enclosure .

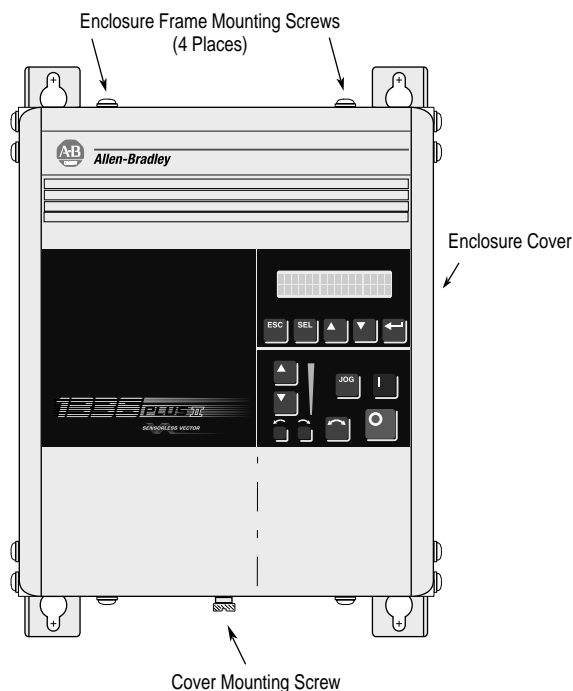

Removal Sequence

1. Remove power from the drive.
2. Remove the screw fastening the Enclosure cover to the Enclosure frame.
3. Pull the bottom of the cover outward to clear the Enclosure frame, then pull the cover down off the upper slots to remove.
4. Remove the four screws from the Enclosure frame top (2 screws) and bottom(2 screws) panels and slide panels down out of engagement slots on side panels. Remove side panels by sliding up off engagement tabs.
5. Check for zero volts at TB1 terminals +DC and -DC.
6. Check for the absence of control voltage before servicing the drive.

Installation

Install the Enclosure in reverse order of removal.



ATTENTION: Replace all guards before applying power to the drive. Failure to replace guards may result in death or serious injury!

Removing Control Interface Board MOD - L4 - L9

Figure 4.2
Control Interface Board. (A Frame Drives)

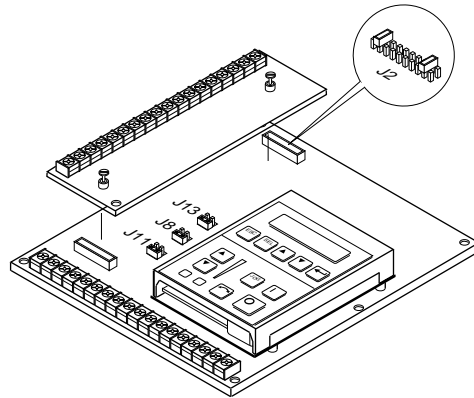

Frames¹ A1 - A4

¹ Refer to page 1-1 for frame reference classifications.

Removal (A Frame Drives)



ATTENTION: Disconnect and lock out power from the drive before disassembling the drive. Failure to disconnect power may result in death or serious injury. Verify bus voltage by measuring the voltage between +DC and -DC on Terminal Block TB1. Do not attempt to service the drive until the bus voltage has discharged to zero volts.



ATTENTION: Wear a wrist type grounding strap when servicing 1336 PLUS Drives. Failure to protect drive components against ESD may damage drive components. Refer to Electrostatic Discharge Precautions at the beginning of this chapter.

1. Remove power from the drive.
2. Remove the Enclosure cover if the drive has an enclosure. Refer to removing the Drive Enclosure in this chapter.
3. Check for zero volts at TB1 terminals +DC and -DC.
4. Check for absence of control voltage.
5. Remove all wires from terminals on TB3
6. Loosen the two captive screws fastening the Control Interface Board to the Main Control Board.
7. Grip the right and left sides of the Control Interface Board and pull the board straight outward from the Main Control Board.

Installation

1. Position the Control Interface Board over the J2 and J4 connectors with the Terminal Block TB3 oriented on the left side of the drive with the drive facing up.
2. Push the Control Interface Board straight down onto the J2 & J4 connectors. Tighten the two captive screws holding the Interface Board to the Main Control Board.
3. Reinstall all wires previously removed at TB3.
4. Reinstall the enclosure cover before re-applying power to the drive.



ATTENTION: Replace all guards before applying power to the drive. Failure to replace guards may result in death or serious injury.

Removing the Main Control Board

Removal (A Frame Drives)

Figure 4.4

Main Control Board Components (A Frame).

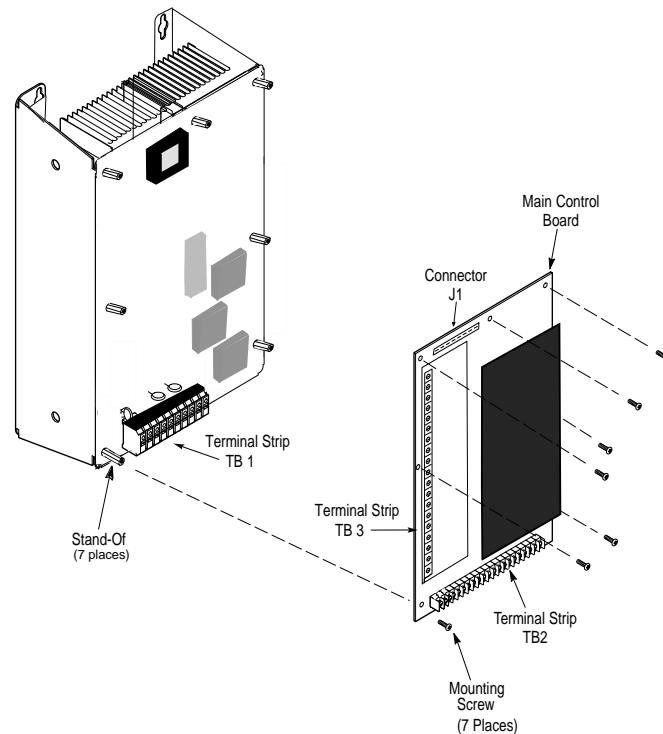

ATTENTION: Disconnect and lock out power from the drive before disassembling the drive. Failure to disconnect power may result in death or serious injury. Verify bus voltage by measuring the voltage between +DC and -DC on Terminal Block TB1. **Do Not** attempt to service the drive until the bus voltage has discharged to zero volts.



ATTENTION: Wear a wrist-type grounding strap when servicing 1336 PLUS II Drives. Failure to protect drive components against ESD may damage drive components. Refer to Electrostatic Discharge Precautions at the beginning of this chapter.

IMPORTANT: Before you remove connections and wires from the drive components, mark the connections and wires to correspond with their component connections and terminals to prevent incorrect wiring during assembly.

1. Remove the Enclosure cover if the drive has an enclosure. Refer to removing the Drive Enclosure in this chapter.
2. Remove power from the drive.
3. Check for zero volts at TB1 Terminals +DC and -DC
4. Check for the absence of control voltage.

Figure 4.5
Option Board Locations. (A Frame)

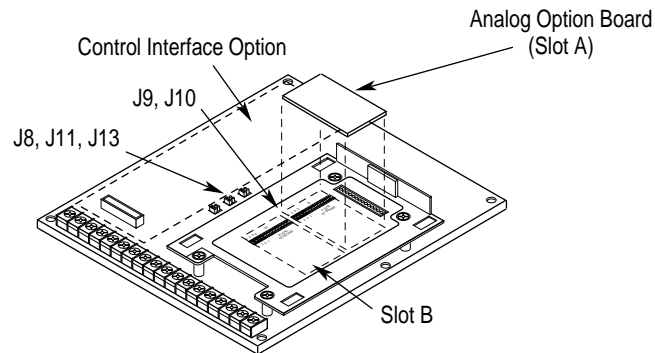

Frames A1 - A4

5. Remove the Control Interface Board (L Option), if used. If a Control Interface Board is not present, and a new Main Control Board will be installed, the jumpers at pins 3 & 4 and 17 & 18 of J2 must be transferred to the same location on the new board.
6. If a HIM (or other snap-in module) is installed, remove it by carefully squeezing the locking tabs in and pulling the HIM straight out. Remove the HIM cradle by removing the four screws securing it to the Main Control Board.
7. If a new Main Control Board will be used, and a Communications Option (1336-GM1, etc.) is installed in the Adapter 6 location it must be removed and reinstalled on the new Main Control Board.
8. If a new Main Control Board will be used, and an Analog Interface Board (LA1, LA2 etc.) is installed in Slot A or B, it must be transferred to the new board. Note placement of the Analog Interface Board and carefully remove the board by releasing standoffs and lifting straight out. Transfer this board (and standoffs, if needed) to the same slot on the new board. Repeat if a second board is present
9. Locate jumpers J8, J11 and J13. Note jumper placement - then transfer jumpers to the same location on the new Main Control Board (if used).
10. Remove the communications connector at J3, the ribbon cable at J1 and all wires at TB2.
11. Remove the six remaining screws (1 was previously removed with the HIM cradle) holding the Main Control Board to the standoffs. Remove the Main Control Board.

Installing the Main Control Board

Installation (A Frame Drives)

1. Position the Main Control Board on the standoffs and install the six screws that were previously removed in step 11 of disassembly. Torque screws to 26 in-lb (3 N-m).
2. Install the HIM cradle to the Main Control Board with four screws.
3. Reinstall the communications connector at J3, the ribbon cable at J1 and all wires at TB2.
4. Reinstall the Control Interface Board on the Main Control Board.
5. Install the HIM in the HIM cradle.

NOTE: Verify that the Analog Option Board(s) are correctly installed in the proper slot for your application. The terminal designations at TB2 change based on the Analog Option board installed and on slot location. Refer to Publication 1336 PLUS-5.70 if you have questions on Analog Option Board installation and set up.

6. Apply power - if a fault occurs, "Reset Defaults". Download parameters (if previously uploaded) from the HIM.

Gate Driver/Power Supply/Precharge Board

IMPORTANT: Individual components such as Bridge Rectifiers and Transistor Modules cannot be tested or replaced separately as they are part of the Gate Driver/Power Supply Board assembly.

If you suspect a problem on the Gate Driver/Power Supply Board, the Drive should be returned to the factory for repair or replacement.

Removing the Fan Assemblies (A4 Frame Drives)

1. Remove power from the drive.
2. Remove the Enclosure cover if the drive has an enclosure.
3. Check for zero volts at TB1 Terminals +DC and -DC
4. Check for the absence of control voltage before beginning fan removal.
5. Disconnect the fan leads at the J2 connector on the Main Control Board (Figure 4.6). Cut any tie wraps fastening the fan leads to the drive frame.
6. Remove the four phillips head screws holding each fan unit and safety shield to the heat sink. Withdraw each fan unit while threading the fan leads down from the top layer of the drive.

Figure 4.6
Fan Assemblies (A4 Frame).

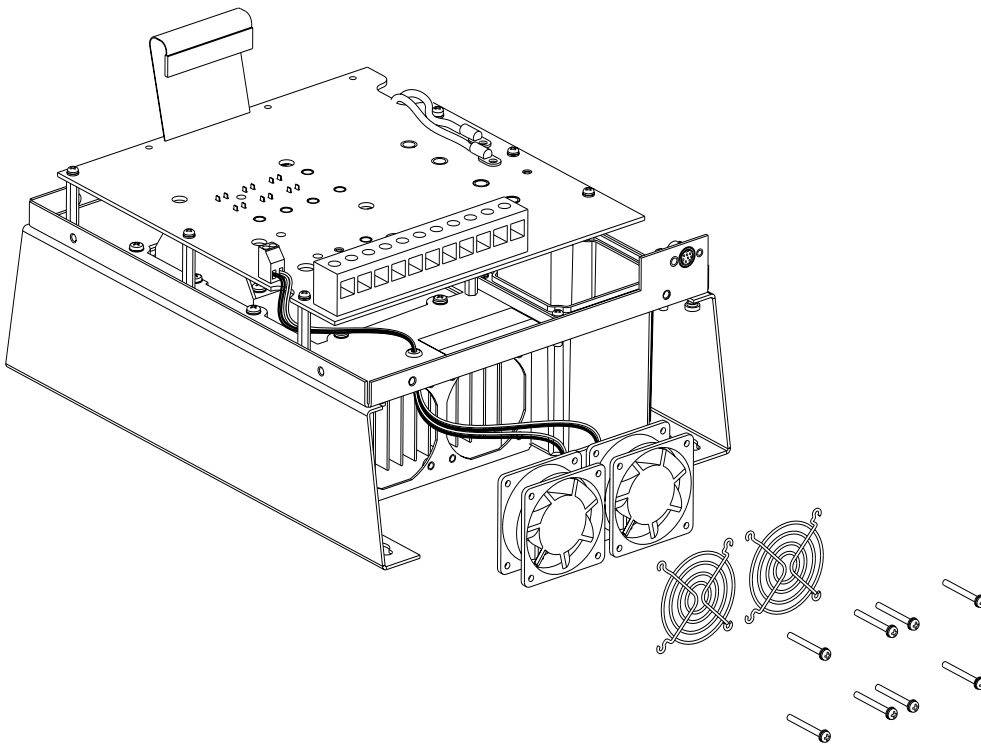

Installing Fan Assemblies (A4 Frame Drives)

1. Make certain power is removed from the drive.
2. Begin to thread the leads on the replacement fan units up thru the opening to the first layer of the drive.
3. Position each fan unit with safety shield on the heat sink and install the four screws thru the shields and the fans into the threaded holes on the heat sink as shown in Figure 4.6. Tighten all screws securely.
4. Install the fan leads at terminal J2 and reroute and fasten the leads in the same location as the previous unit.
5. Install all covers and re-power the drive.

To contact **Drives Technical Support** . . .
Tel: (1) 262 512-8176, Fax: (1) 262 512-2222
Email: support@drives.ra.rockwell.com, Online: www.ab.com/support/abdrives

www.rockwellautomation.com

Power, Control and Information Solutions Headquarters

Americas: Rockwell Automation, 1201 South Second Street, Milwaukee, WI 53204-2496 USA, Tel: (1) 414.382.2000, Fax: (1) 414.382.4444
Europe/Middle East/Africa: Rockwell Automation, Vorstlaan/Boulevard du Souverain 36, 1170 Brussels, Belgium, Tel: (32) 2 663 0600, Fax: (32) 2 663 0640
Asia Pacific: Rockwell Automation, Level 14, Core F, Cyberport 3, 100 Cyberport Road, Hong Kong, Tel: (852) 2887 4788, Fax: (852) 2508 1846