



# Electric Trolling Motor

NV Kayak Series

---

User's Manual

Please read and retain this manual before using product

REACH

RoHS



# TABLE OF CONTENTS

## Contents

<b>GENERAL INFORMATION</b>	4
<b>SPECIFICATIONS</b>	4
<b>WIRING AND BATTERY RECOMMENDATIONS</b>	5
<b>Battery Type</b>	5
<b>Circuit Protection</b>	5
<b>Cable Size</b>	5
<b>SAFETY INFORMATION</b>	6
<b>FIRST TIME RUNNING</b>	7
<b>MOTOR USAGE</b>	8
<b>Battery Connection Method (12 Volt only)</b>	8
<i>Connection with one battery (12V DC)</i>	8
<i>Connection with two batteries in parallel (12V DC)</i>	8
<b>How To Control The Motor</b>	9
<i>On/Off Speed Control</i>	9
<i>Battery Level Indicator</i>	9
<i>Adjusting Motor Depth</i>	9
<i>Raising The Motor</i>	10
<i>Lowering The Motor</i>	10
<b>TRANSOM MOUNT INSTALLATION</b>	11
<b>HOW TO REPLACE THE PROPELLER</b>	12

<b>DAILY MAINTENANCE</b>	<b>13</b>
<b>TROUBLE SHOOTING</b>	<b>14</b>
<b>Loss Of Power</b>	<b>14</b>
<b>Motor Makes Excessive Noise Or Vibration</b>	<b>14</b>
<b>Motor Fails To Run</b>	<b>15</b>
<b>Motor Loses One Or More Speeds</b>	<b>15</b>
<b>ABOUT CIRCUIT BREAKER</b>	<b>15</b>
<b>Function of the circuit breaker</b>	<b>16</b>
<b>Declaration of Conformity for Recreational Craft</b>	<b>17</b>
<b>CONTACT US</b>	<b>17</b>

## GENERAL INFORMATION

Thank you for purchasing our product and we wish that you enjoy it.

Newport Vessels trolling motors are designed and developed by professional engineers and have been continually developed over a number of years. There are a wide range of Newport Vessels outboard motors, from 36lbs to 86lbs to suit every customer's requirements and application.

Please read and retain this manual before using this electrical motor. This manual contains information that describes the procedure for safe operation and daily maintenance of your electrical motor. Safe operation will prevent personal injury and product damage.

## SPECIFICATIONS

ITEMS-No.	THRUST IN LBS	THRUST IN KG	INPUT	INPUT POWER	MAX SPEED*
NVK-36	36	16.3	12V, 29A	348W	4.8MPH
NVK-55	55	25.0	12V, 52A	624W	10.8MPH

\* Since speed depends on many factors, such as loading, water condition, hull type and wind speed etc., it would be difficult to give an accurate speed rating, we give the speed for reference purposes:  
 Kayak size, 3.7m (12')\ Loading, 90kg (190lbs)\ Quiet water.

## WIRING AND BATTERY RECOMMENDATIONS

### Battery Type

Recommended battery(s): 12-volt Deep Cycle battery or Marine battery. To extend running time either a larger capacity or an additional battery can be used. See section on battery connection method. NOTE: 86lbs model requires a 24-volt battery.

### Circuit Protection

It is recommended to install a manual reset circuit breaker in the electric outboard motor leads within 1.8m (72 Inches) of the battery(s).

### Cable Size

If extending the standard battery cable supplied with the product, Newport Vessels recommends the use of 13mm<sup>2</sup> wire (8-gauge wire, AWG).

## WARNING

Batteries contain sulfuric acid, which can cause severe burns. Avoid contact with skin, eyes and clothing. The battery also produces hydrogen and oxygen gases when being charged. This potentially explosive mixture escapes through the fill vent cell caps and may form an explosive atmosphere around the battery for several hours after it has been charged. Electrical arcing or flames can ignite the gas and cause an explosion, which may shatter the battery and could cause blindness or other serious injury.

## WARNING

Be sure all switches are in the OFF position before connecting to battery or batteries. Electrical arcing near the battery could ignite hydrogen gas and cause the battery to explode.

## **SAFETY INFORMATION**

Do not allow children to operate the electric outboard motor.

Do not modify the unit in any way or add accessories not intended for this product.

Never fully submerge the unit, if unit is accidentally submerged disconnect battery and leave to dry.

To prevent accidental damage of the fiberglass shaft, do not over tighten the mounting bracket.

Only use this product between the temperatures of -20C to +45C (-4F to +113F).

**User(s) should always wear approved Life Jackets.**

A black warning symbol consisting of a triangle with an exclamation mark inside.

## **WARNING**

Always disconnect power from the motor when replacing propeller, removing debris around the prop, charging batteries, transporting boat or when the motor is not in use.

## **FIRST TIME RUNNING**

1. Place Electric Outboard onto the back of the vessel in the Stow away position.
2. Loosely tighten Transom Mounting Screws till they grip the Transom Mount.
3. Press the Tilt Lever and slowly let the motor enter the water.
4. Use the Depth Adjuster Collar to adjust the height of motor (Recommend running depth between 150mm-300mm (6in-12in) below the waterline).
5. When you are satisfied that the motor is at a safe depth and isn't too close or in danger of hitting the bottom of the lake, river or other water ways you may proceed to tighten the Transom Mounting Screws.
6. Once this is done it should be safe to connect the battery to the motor. Ensure that the twist grip is in the neutral position and that the nuts are tight on the terminals to prevent a poor connection.
7. Select the desired speed and direction using twist grip on the tiller arm.
8. Do not go from full forward speed to full reverse speed without letting the propeller stop turning first or motor damage may occur.

## MOTOR USAGE

This product does not include batteries; please choose a battery with 12V (24V for 86LBS motor) output to fit this motor, the recommended type of battery is deep cycle battery or marine battery, as they will last much longer and are designed for this application.

### Battery Connection Method (12 Volt only)

#### ***Connection with one battery (12V DC)***

The red wire should connect to positive; the black wire should connect to negative.

(It is recommended to install circuit breaker in line with positive lead.)

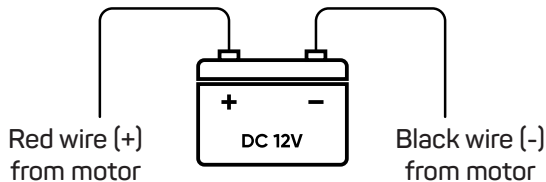

#### ***Connection with two batteries in parallel (12V DC)***

The red wire should connect to positive; the black wire should connect to negative.

(It is recommended to install circuit breaker in line with positive lead.)

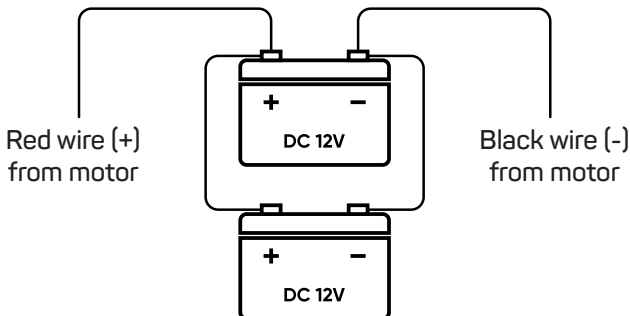



## How To Control The Motor

Please rotate handle to select desired speed.

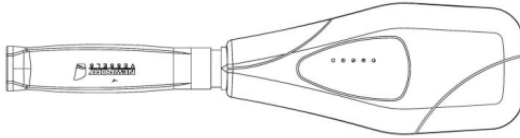

### **WARNING**

Remember to always disconnect from the battery(s) once the motor leaves water as a rotating propeller can cause personal injury.

### ***On/Off Speed Control***

Rotate handle clockwise to obtain any of the 5 forward speeds. Rotate handle counter clockwise for any of the 3 reverse speeds. To stop the motor from running, position the handle following the arrow marker and position on level 0.

### ***Battery Level Indicator***

There are 5 LED lights on the top cover, when four (4) blue LED's are out, the meter is indicating that the input voltage is less than 9.5V (normal voltage draw, 12V). It is advised to disconnect the motor from the battery to prevent damage to the battery and recharge.

### ***Adjusting Motor Depth***

Position the depth adjustment collar so the propeller blades are sub-

merged 150mm - 300mm (6inches - 12inches) below the waters surface.

### ***Raising The Motor***

It is recommended to disconnect the battery before carrying out this procedure to prevent accidental running of the motor. To raise the motor out of the water push and hold the tilt lever and with the other hand push down on the end of the handle to bring the motor up and out of the water. Then release the tilt lever to lock in place.

### ***Lowering The Motor***

It is recommended to disconnect the battery before carrying out this procedure to prevent accidental running of the motor. Press the tilt lever, while with the other hand; hold onto the end of the handle to steady the motor into the water. Once lowered release the tilt lever to lock into position.

## **! CAUTION**

Remember to wash the motor by using fresh water after being used in salt water as it can greatly reduce the possibility of corrosion.

## TRANSOM MOUNT INSTALLATION

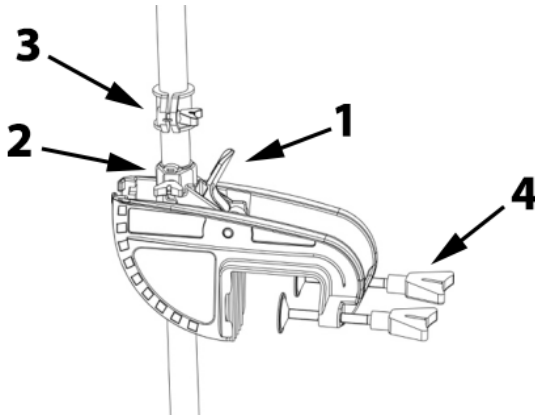

### ! CAUTION

Before the installation, make sure the area between column and bracket is clear.

1. Tilt Position Lever - This lever allows the user to adjust the tilt (angle) of the motor. Push tilt position lever, adjust tilt of motor, release lever.
2. Steering Tension Adjustment -To adjust the steering resistance, simply tighten or loosen the tension knob located on front of the mount.
3. Depth Adjustment Collar -The depth of the motor can be adjusted up and down by loosening the depth collar tension knob located on the column directly above the mount. The column can be adjusted and the motor can be positioned at the desired depth by re-tightening the tension knob.

4. Transom Screws -The transom clamp screws allow for easy motor removal and installation. Mount your motor on the transom then tighten the transom clamp screws securely.

## CAUTION

The motor can only be used in water deeper than 0.7m.

### HOW TO REPLACE THE PROPELLER

## CAUTION

Make sure that the motor has been disconnected from batteries.



STEP 1



STEP 2



STEP 3

Hold the propeller blade and loosen the propeller nut using the prop spanner supplied or a set of needle nose pliers. Remove the propeller nut. Pull the propeller straight off. If prop is stuck, grasp one blade with

one hand and tap on the backside of the opposite blade lightly with a rubber mallet, until the propeller comes off. If the propeller pin is bent, replace it. Align the new propeller with the propeller pin. Reinstall the propeller nut and tighten firmly by hand, tighten with spanner another 1/4 turn.

## CAUTION

Do not strike bent prop pin with hammer to remove pin. Damage to motor armature may occur that would not be covered by warranty.

### DAILY MAINTENANCE

1. Check behind the propeller after each day for weeds, fishing line or other debris that may get wrapped behind the propeller.
2. Lubricate all the pivot points with a **non-aerosol** lubricant. Never use an aerosol lubricant as many types contain harmful propellants that can cause damage to various parts of your electric motor.
3. Check tightness of the battery lead connections.
4. Visually check condition of main battery cables.
5. Inspect for loose or corroded wiring connections.
6. Always thoroughly rinse your electric outboard motor with fresh water after every use in salt water. Only rinse the areas that have been in contact with salt water, avoid getting the top cover wet as this may damage the circuitry inside.

7. Inspect for tightness of all nuts, bolts and screws.
8. Recharge batteries after each use. Follow the battery manufacturer's recommendations for battery maintenance.
9. During freezing temperatures, when your electric motor is not being used, it should be stored in an area where it will not freeze.
10. Never connect the wires to the wrong battery terminal. You must disconnect the battery during maintenance.

## **TROUBLE SHOOTING**

### **Loss Of Power**

Propeller may be damaged. Remove propeller, clean and replace.

Battery connections may be corroded.

Battery has low voltage. Recharge.

Battery may be faulty, recharge and check.

Insufficient cable size from battery to motor wiring, 13mm<sup>2</sup> thickness / 6 gauge wire (AWG) recommended.

Bad or faulty connection in boat wiring or electric motor wiring.

Permanent magnet cracked or chipped. Motor will whine or grind.

### **Motor Makes Excessive Noise Or Vibration**

Propeller may be damaged or unbalanced.

Check to see if propeller is secured.

Bent armature. Remove propeller, set at medium speed, turn unit on and check for armature wobble.

Turn propeller by hand. It should turn freely with a slight magnetic drag.

Bearing bushes may be worn out.

### **Motor Fails To Run**

Check fuse circuit breaker on boat for electric motor.

Check for loose or corroded connections.

Check plug for loose or bad connection.

Test main rotary switch.

Turn prop by hand. It should turn freely with a slight magnetic drag.

Total battery failure. Recharge and check voltage.

Propeller damaged.

### **Motor Loses One Or More Speeds**

Loose wire on rotary switch. Check wiring diagram.

Lose connection in top housing.

Rotary switch damaged.

Speed coils in lower unit may be burned.

## **ABOUT CIRCUIT BREAKER**

During the usage of the electric outboard motor, the propeller can sometimes get stuck by weeds, fishing lines, or fishing webs. Sometimes, due to the variance of the water depth, the propeller can become covered by silt. If those situations occur, quickly disconnect the battery and clean up the propeller. (Please DO NOT rise steps and increase the thrust of electric outboard motor to solve the problem, or it may cause permanent damages to the electric outboard motor.)

The characteristics between the electric outboard motor and gasoline outboard motor are different. If the propeller of the motor gets stuck, the gasoline outboard motor will shut down to not cause any permanent damage to the motor itself. However, the electric outboard will draw extremely large current due to the motor stall and can generate large amounts of heat that can damage important components in the motor such as switch, rotor and other connecting parts or even cause serious battery explosions.

In some muddy water areas, it can be hard for the user to recognize that the motor is stalled. To prevent these situations from occurring, it is strongly recommended to use circuit breaker to protect the electric outboard motor. If the current draw of the electric outboard motor exceeds the limit of normal usage, the circuit breaker will cut off the power automatically to prevent any possible damage to the electric outboard motor. The circuit breaker has a reset button and is therefore reusable.

To prevent the rotor coil damage from exceeding current, it is highly recommended to use a circuit breaker to protect electric outboard motor.

### Function of the circuit breaker

During the usage of the electric outboard motor, when the propeller is stuck by the weeds, small stones, fishing lines or so forth, the circuit breaker will cut off the power automatically to prevent the damage of the motor's electrical parts.

If the circuit breaker cuts off the power, please disconnect the battery first, then check and clear any obstacles. At last, press the reset button on the circuit breaker and reconnect the battery, the electric outboard motor will now be able to continue functioning properly.

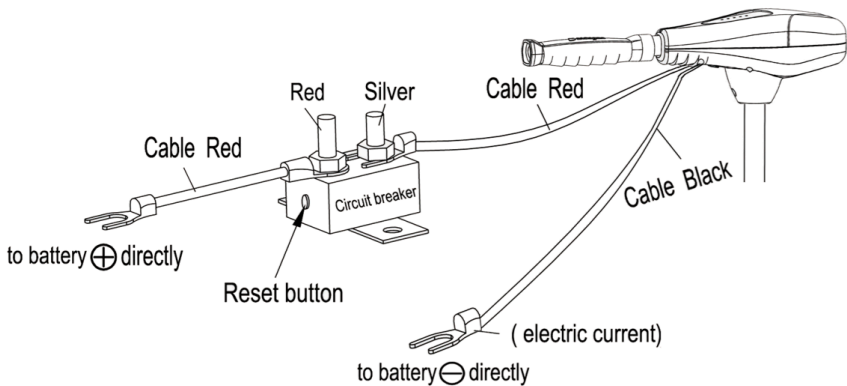



# Declaration of Conformity for Recreational Craft

**Propulsion Engine with the requirements of Directive  
89/392/EEC as amended by 89/336/EEC.**

---

**Engine type approved according to: Directives 89/392/EEC, 89/336/EE**

**Description of Engine(s) and Essential Requirements**

**Engine Type:** Outboard Engine

**Fuel Type:** Electric

---

This declaration of conformity is issued under the sole responsibility of the manufacturer. I declare on behalf of the manufacturer that the motor(s) is (are) in conformity with the type(s) for which above mentioned EC, EMC and ROHC type-examination or type approval certificate(s) has (have) been issued and it will meet the requirements of Directive 89/392/EEC, 89/336/EEC as amended when installed in a recreational craft, in accordance with the manufacturer's supplied instructions.

## CONTACT US

If you have any other enquires regarding the motor please contact Newport Vessels.

**(866) 721-0002**

**[www.newportvessels.com](http://www.newportvessels.com)**

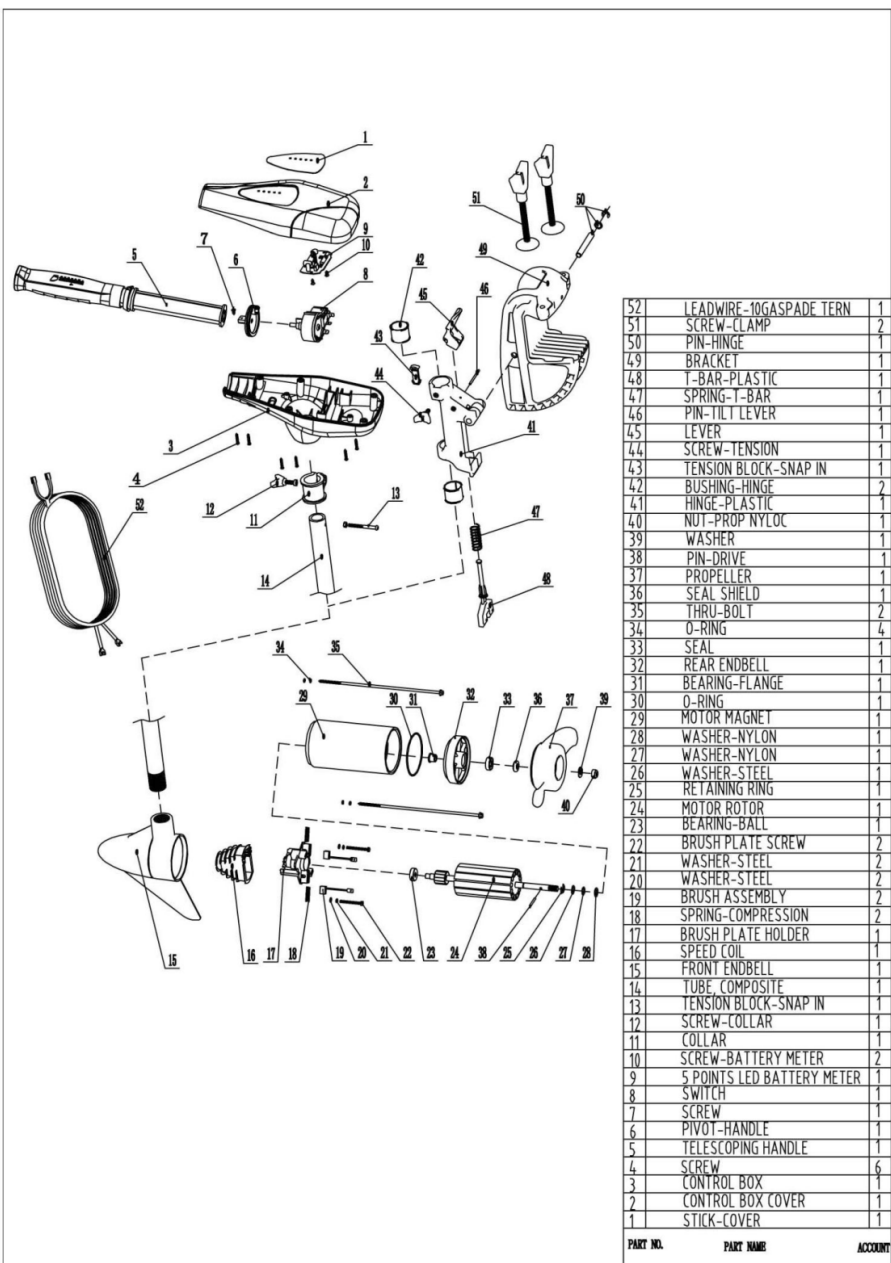

52	LEADWIRE-10GASPADE TERN	1
51	SCREW-CLAMP	2
50	PIN-HINGE	1
49	BRACKET	1
48	T-BAR-PLASTIC	1
47	SPRING-T-BAR	1
46	PIN-TILT LEVER	1
45	LEVER	1
44	SCREW-TENSION	1
43	TENSION BLOCK-SNAP IN	1
42	BUSHING-HINGE	2
41	HINGE-PLASTIC	1
40	NUT-PROP NYLOC	1
39	WASHER	1
38	PIN-DRIVE	1
37	PROPELLER	1
36	SEAL SHIELD	1
35	THRU-BOLT	2
34	O-RING	4
33	SEAL	1
32	REAR ENDBELL	1
31	BEARING-FLANGE	1
30	O-RING	1
29	MOTOR MAGNET	1
28	WASHER-NYLON	1
27	WASHER-NYLON	1
26	WASHER-STEEL	1
25	RETAINING RING	1
24	MOTOR ROTOR	1
23	BEARING-BALL	1
22	BRUSH PLATE SCREW	2
21	WASHER-STEEL	2
20	WASHER-STEEL	2
19	BRUSH ASSEMBLY	2
18	SPRING-COMPRESSION	2
17	BRUSH PLATE HOLDER	1
16	SPEED COIL	1
15	FRONT ENDBELL	1
14	TUBE, COMPOSITE	1
13	TENSION BLOCK-SNAP IN	1
12	SCREW-COLLAR	1
11	COLLAR	1
10	SCREW-BATTERY METER	2
9	5 POINTS LED BATTERY METER	1
8	SWITCH	1
7	SCREW	1
6	PIVOT-HANDLE	1
5	TELESCOPING HANDLE	1
4	SCREW	6
3	CONTROL BOX	1
2	CONTROL BOX COVER	1
1	STICK-COVER	1

PARTY NO.      PARTY NAME      ACCOUNT