

IXG System

IP network-compatible intercom

IXG Support Tool Setting Manual: Property Manager Mode

Software version: 1.0.0.0 or later

Important

- Before configuring and using the system, read Setting Manual (this document) and Operation Manual carefully.
- For the installation and connection of each device, refer to "Installation Manual."
- Begin installation after reading and understanding the procedures for system configuration.
- The setting file is required for post-installation maintenance and service. Write the setting file to a CD-R or other media and be sure to give it to the customer.
- The illustrations and images in this manual may vary from the actual ones.
- Configure each function according to regulations, laws, and policies related to personal information in the applicable country and municipality.

Table of contents

Introduction

| | |
|--|----|
| 1. Notational symbols in this manual | 5 |
| 2. Device type | 6 |
| 3. Product manuals | 7 |
| 4. Station description | 8 |
| 4.1 Tenant Station (IXG-2C7(-*)) | 8 |
| 4.2 Master Station (IX-MV7-*) | 9 |
| 4.3 Guard Station (IXG-MK) | 11 |
| 4.4 Entrance Station (IXG-DM7(-*)) | 13 |
| 4.5 Video Door Station (IX-EA, IX-EAU)/Door Station (IX-FA) | 14 |
| 4.6 Video Door Station (IX-DA)/Door Stations (IX-BA) | 16 |
| 4.7 Video Door Station (IX-DV, IX-DVF(-*)) /Door Stations (IX-SSA(-*)) | 18 |
| 4.8 Lift Control Adaptor (IXGW-LC) | 23 |
| 4.9 Gateway Adaptor (IXGW-GW) | 25 |
| 5. Configuring the system | 27 |
| 6. Flowcharts for configuring the system | 28 |
| 7. Flowcharts for Mobile App Integration | 29 |
| 7.1 Registering the Mobile App | 29 |
| 7.2 Adding a Mobile App to Each Unit | 31 |
| 7.3 When the type of mobile device registered to a Residential unit was replaced | 32 |
| 7.4 When the type of mobile device registered to a Guard or a Commercial unit was replaced | 34 |

Startup and Configuration

| | |
|--|----|
| 1. System requirements | 36 |
| 2. Installing IXG Support Tool | 37 |
| 3. Login and registration of the station | 38 |
| 4. How to Configure | 39 |
| 4.1 Settings window | 39 |
| 4.2 How to Configure | 40 |
| 5. System settings list | 42 |

Menu bar

| | |
|---|----|
| 1. File | 45 |
| 1.1 Select Existing System | 45 |
| 1.2 Delete Existing System | 46 |
| 1.3 Exporting the IXG Support Tool System Configuration | 47 |
| 1.4 Outputting IXG Supervision Tool Data | 48 |
| 1.5 IXG Support Tool Settings | 49 |
| 1.6 Exit | 52 |
| 2. Connection | 53 |
| 2.1 Station Search | 53 |
| 2.2 Download Settings | 54 |

| | |
|--|----|
| 2.3 Upload Settings | 56 |
| 2.4 Download Log File | 59 |
| 3. App Integration | 60 |
| 3.1 Upload Settings to IXG Cloud Server | 61 |
| 3.2 Applying QR Code for App Registration to a station | 64 |
| 3.3 Export QR Code for App Registration | 65 |
| 3.4 Site List | 66 |
| 3.5 Property manager Account Settings | 67 |
| 3.6 Manual IXG Cloud Server and Gateway Sync | 71 |
| 4. View | 72 |
| 5. Language | 73 |
| 6. Help | 74 |
| 6.1 About | 74 |

System Settings

| | |
|---|-----|
| 1. Site Information (Move-in Settings) | 76 |
| 1.1 Units / Stations | 76 |
| 2. Station Information (Move-in Settings) | 79 |
| 2.1 Identification | 79 |
| 3. System Information (Move-in Settings) | 81 |
| 3.1 Station List | 81 |
| 3.2 Mobile App List | 84 |
| 3.3 Network Camera List | 86 |
| 3.4 Group | 90 |
| 4. Call Settings (Move-in Settings) | 93 |
| 4.1 Called Stations (Door/Sub Stations) | 93 |
| 4.2 Guard Button (IXG-2C7) | 96 |
| 5. Move-out Settings (Move-out Settings) | 97 |
| 5.1 Resident Move-out | 97 |
| 5.2 Delete Unit Information | 98 |
| 6. Entrance Station Settings (Misc.) | 99 |
| 6.1 Access Code | 99 |
| 6.2 Welcome Screen | 103 |
| 7. Transfer Settings (Misc.) | 105 |
| 7.1 Absent Transfer | 105 |
| 7.2 Delay Transfer | 107 |
| 7.3 Schedule Transfer | 109 |

Additional Settings

| | |
|--|-----|
| 1. Confirming Station Information | 116 |
| 1.1 Confirming Station Information on the Entrance Station | 116 |





Introduction

This manual describes IXG Support Tool in detail.

The IXG System offers a separate manual for Installation, Settings, and Operations. Refer to the relevant manual.

1. Notational symbols in this manual

The following symbols identify important information concerning operational procedures.

| | |
|---|---|
|  | Indicates that users may require caution (including warning / caution). |
|  | Alerts users to prohibited actions. |
|  | Restricts user actions / provides instructions. |
|  | Tips and additional information for operation. |

- Terms displayed on master station and PC screens are indicated as **[XXXX]**.
- Page reference are shown as "[Title \(→ page XX\)](#)," [\(→ page XX\)](#), or [page XX](#).

2. Device type

The stations are shown as below.

| | Device Type | Example Model Name |
|------------------------------------|-------------------|--|
| Tenant Stations | IXG-2C7(-*) | IXG-2C7, IXG-2C7-L |
| Master Stations | IX-MV7-* | IX-MV7-HW, IX-MV7-W, IX-MV7-HB, IX-MV7-B |
| Guard Stations | IXG-MK | IXG-MK※1 |
| Video Entrance Stations | IXG-DM7(-*) | IXG-DM7, IXG-DM7-HID |
| Video Stations | IX-DV, IX-DVF(-*) | IX-DV, IX-DVF, IX-DVF-P, IX-DVF-L, IX-DVF-2RA, IX-DVF-RA |
| | IX-DA | IX-DA |
| Audio Stations | IX-SSA(-*) | IX-SSA, IX-SSA-2RA, IX-SSA-RA |
| | IX-BA | IX-BA |
| | IX-FA | IX-FA※2 |
| Lift Control Adaptor | IXGW-LC | IXGW-LC |
| Gateway Adaptor | IXGW-GW | IXGW-GW |
| Intercom Application (AIPHONE IXG) | Intercom App | ASP-IXGI, ASP-IXGA |

※1 Scheduled for release in the 3rd quarter of 2020.

※2 Japan only

3. Product manuals

Read the "Installation Manual," "Setting Manual," and "Operation Manual" as needed. Have the person who installs or configures the product refer to the relevant manuals.

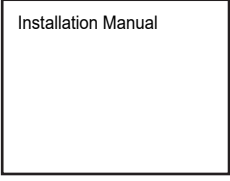
| | |
|--|---|
|  <p>Installation Manual</p> | <p>Installation Manual (comes with each station.) Refer to when installing and connecting each station. (For installers)</p> |
| <p>The manuals listed to the right can be found on our Web site at "https://www.aiphone.net/product/support/" for download and reference. Download and refer to these manuals as necessary.</p> | <p>IXG Support Tool Setting Manual (Electronic format (PDF file).) Describes how to configure and maintain the system using IXG Support Tool. (For system administrator)</p> |
| | <p>Monitoring Software (IXG Supervision Tool) Operation Manual (Electronic format (PDF file).) Describes how to use the IXG Supervision Tool. (For system administrator)</p> |
| | <p>Operation Manual (Electronic format (PDF file).) Describes how to use each station. (For user)</p> |
| | <p>Installation Manual (Electronic format (PDF file).) Describes how to install each station. (For installers)</p> |

4. Station description

4.1 Tenant Station (IXG-2C7(-*))

■ Part names

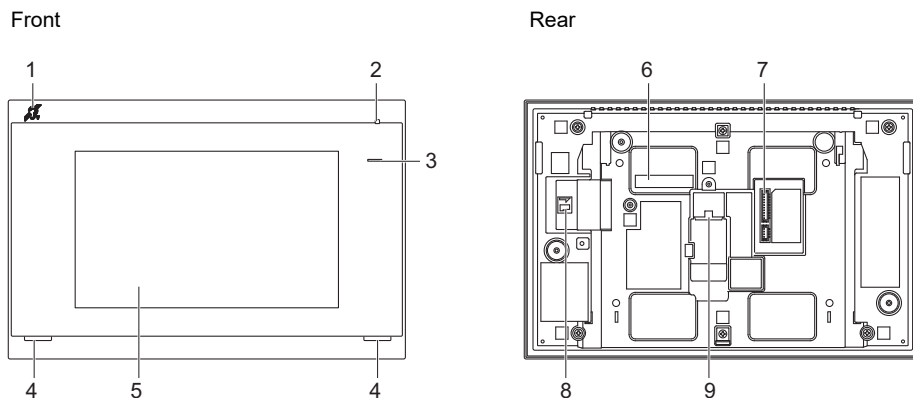

| | | | |
|---|--|---|---------------------------|
| 1 | Hearing aid T-mode compatibility symbol (IXG-2C7-L only) | 6 | MAC address |
| 2 | Microphone | 7 | Option connector terminal |
| 3 | Status indicator (Blue) | 8 | microSD card slot |
| 4 | Speaker | 9 | LAN (PoE) port |
| 5 | Touchscreen LCD | | |

■ Indicators

☀: ON, □: OFF

| Name | Status (pattern) | Description |
|------------------|-------------------|--|
| Status indicator | Blue flashing | Booting |
| | | Communication failure |
| | | Firmware version updating |
| | Blue light | Operating normally (may not light up when in standby depending on setting) |

💡 Note

- For a status other than those noted here, refer to "Operation Manual."
- The display language is English by default.

4.2 Master Station (IX-MV7-*)

■ Part names

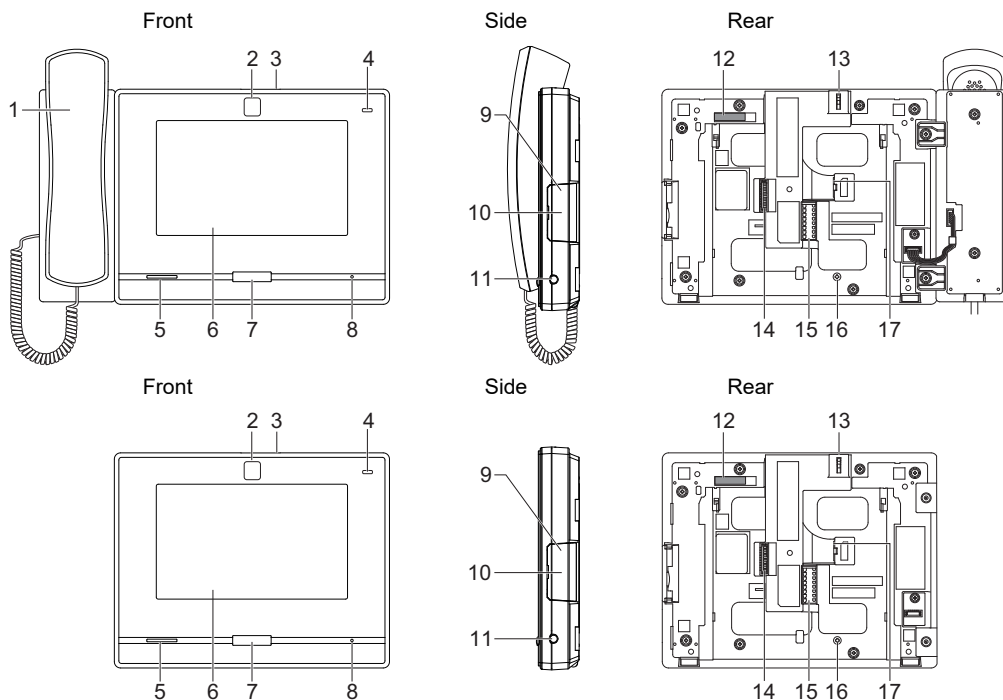





| | | | |
|---|-------------------------------------|----|------------------------------------|
| 1 | Handset | 10 | microSD card slot*1 |
| 2 | Camera | 11 | 3.5 mm jack |
| 3 | Camera privacy cover lever (on top) | 12 | MAC address |
| 4 | Status indicator (Orange/Blue) | 13 | Camera angle adjustment lever |
| 5 | Speaker | 14 | Option connector terminal |
| 6 | Touchscreen LCD | 15 | Low-voltage connection terminal |
| 7 | Home button | 16 | Desktop-stand fastening screw hole |
| 8 | Microphone | 17 | LAN port |
| 9 | Reset button*1*2 | | |

*1 Found by opening cover.

*2 Press and hold the reset button for at least 1 second (less than 5 seconds), then release to restart (reset).

■ Indicators

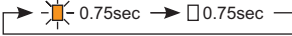
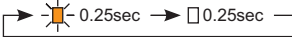
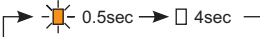
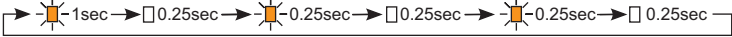
: ON,  : OFF

| Name | Status (pattern) | Description |
|------------------|--|--|
| Status indicator |  | Booting |
| |  | Device error, Startup error |
| |  | Communication failure Line supervision and device check error |
| |  | Firmware version updating |
| |  | Initializing |
| Blue light |  | Standby(Depends on setting) |



Note

- For a status other than those noted here, refer to "Operation Manual."
- The display language is English by default.

4.3 Guard Station (IXG-MK)

■ Part names

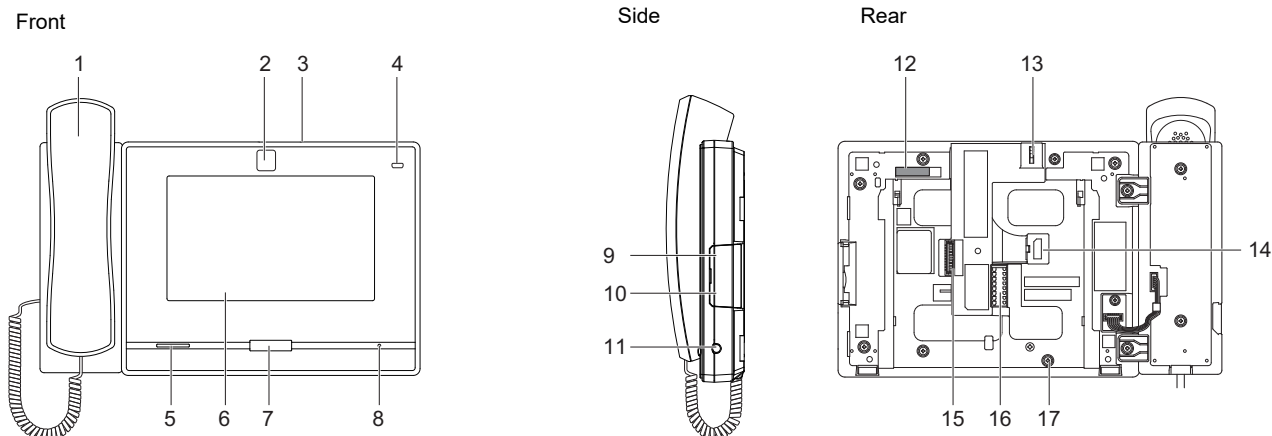



| | | | |
|---|-------------------------------------|----|------------------------------------|
| 1 | Handset | 10 | microSD card slot*1 |
| 2 | Camera | 11 | 3.5 mm jack |
| 3 | Camera privacy cover lever (on top) | 12 | MAC address |
| 4 | Status indicator (Orange/Blue) | 13 | Camera angle adjustment lever |
| 5 | Speaker | 14 | LAN (PoE) port |
| 6 | Touchscreen LCD | 15 | Option connector terminal |
| 7 | Home button | 16 | Low-voltage connection terminal |
| 8 | Microphone | 17 | Desktop-stand fastening screw hole |
| 9 | Reset button*1*2 | | |



*1 Found by opening cover.

*2 Press and hold the reset button for 1 - 4 seconds, then release to restart station.

*3 Scheduled for release in the 3rd quarter of 2020.

■ Indicators

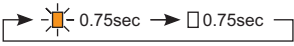
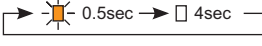
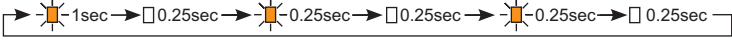
: ON,  : OFF

| Name | Status (pattern) | | Description |
|------------------|------------------|--|--|
| Status indicator | Orange flashing |  | Booting |
| | |  | Communication failure |
| | |  | Firmware version updating |
| | |  | Initializing |
| | Blue light |  | Operating normally (may not light up when in standby depending on setting) |



Note

- For a status other than those noted here, refer to "Operation Manual."
- The display language is English by default.

4.4 Entrance Station (IXG-DM7(-*))

Part names

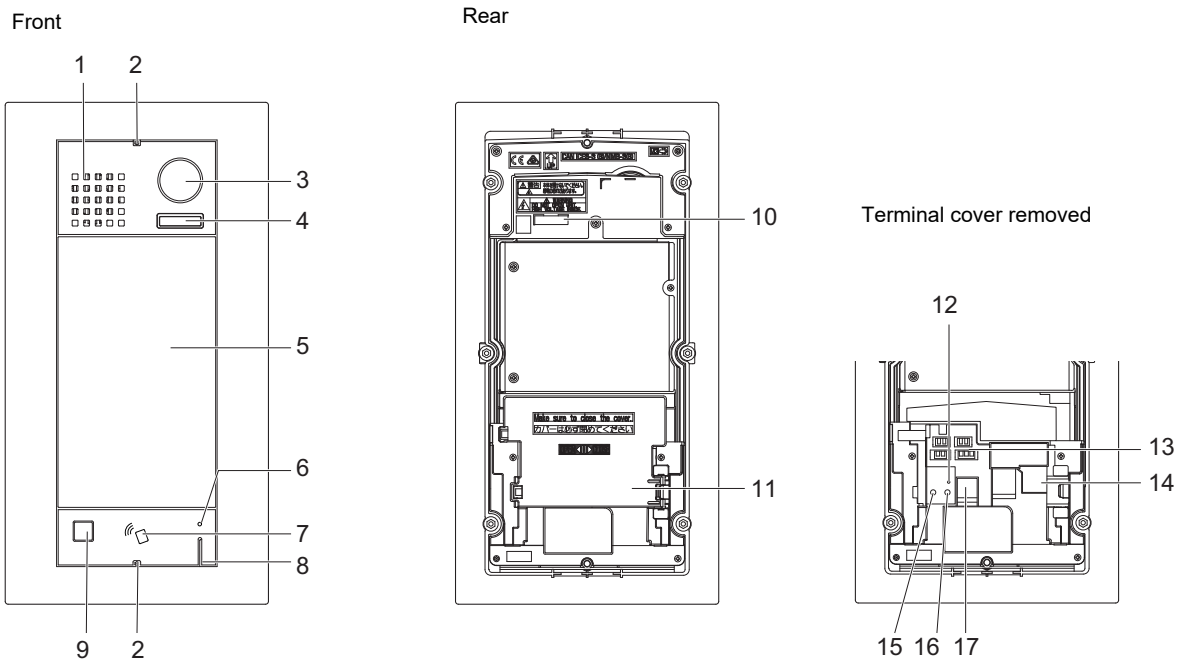

| | | | |
|---|---|----|--|
| 1 | Speaker | 10 | MAC address |
| 2 | Special screw | 11 | Terminal cover |
| 3 | Camera | 12 | microSD card indicator (Red)* ³ |
| 4 | LED for night illumination* ¹ | 13 | Connectors* ³ |
| 5 | Touchscreen LCD | 14 | LAN (PoE) port* ³ |
| 6 | Card reader indicator (Red/Green)* ² (IXG-DM7-HID only) | 15 | Reset button* ³ * ⁴ |
| 7 | Card reader (IXG-DM7-HID only) | 16 | microSD card release button* ³ |
| 8 | Microphone | 17 | microSD card slot* ³ |
| 9 | Sensor | | |

*1 Lights ON when rebooting.

Flashes when the station is booting or during ID/password initialization.

*2 Always lit ON red. If the proximity key is authenticated, it will light ON (green) for approximately 3 seconds.

*3 Found by opening terminal cover.

*4 Press and hold the reset button for 1 - 4 seconds, then release to restart station.

Note

- The display language is English by default.

4.5 Video Door Station (IX-EA, IX-EAU)/Door Station (IX-FA)

Part names

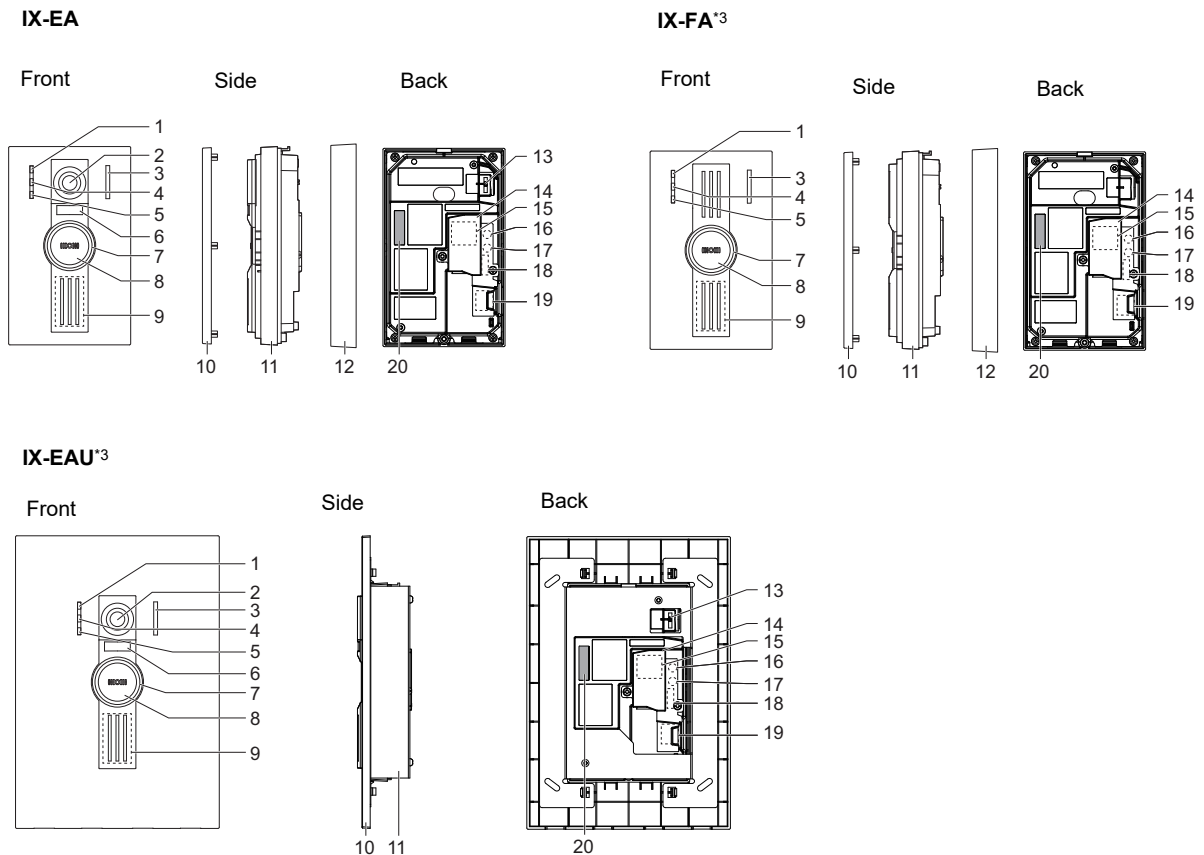



| | | | |
|----|---|----|-------------------------------|
| 1 | Call indicator (Green) | 11 | Main unit |
| 2 | Camera | 12 | Mount |
| 3 | Microphone | 13 | Camera angle adjustment lever |
| 4 | Communication indicator (Orange) | 14 | Terminal cover |
| 5 | Door release indicator (Green) | 15 | LAN port*1 |
| 6 | LED for night illumination | 16 | Reset button*1*2 |
| 7 | Status indicator (Orange/Blue) The ring around the button will illuminate. | 17 | microSD card release button*1 |
| 8 | Call Button | 18 | Option connector terminal*1 |
| 9 | Speaker | 19 | microSD card slot*1 |
| 10 | Panel | 20 | MAC address |





















*1 Accessible when terminal cover is opened.

*2 Press and hold the reset button for 1 - 4 seconds, then release to restart station.

*3 Japan only

■ Indicators

: ON,  : OFF

| Name | Status (pattern) | | Description |
|------------------|------------------|--|----------------------------------|
| Status indicator | Orange flashing |  0.75sec →  0.75sec | Booting |
| | |  0.25sec →  0.25sec | Device error, Startup error |
| | |  0.5sec →  4sec | Communication failure |
| | |  1sec →  0.25sec →  0.25sec →  0.25sec →  0.25sec →  0.25sec | Firmware version updating |
| | |  2sec →  0.25sec →  0.25sec →  0.25sec | Mounting/unmounting microSD card |
| | |  1sec →  0.25sec →  0.25sec →  0.25sec | Initializing |
| | Blue light |  | Standby |



Note

- For a status other than those noted here, refer to "Operation Manual."

4.6 Video Door Station (IX-DA)/Door Stations (IX-BA)

■ Part names

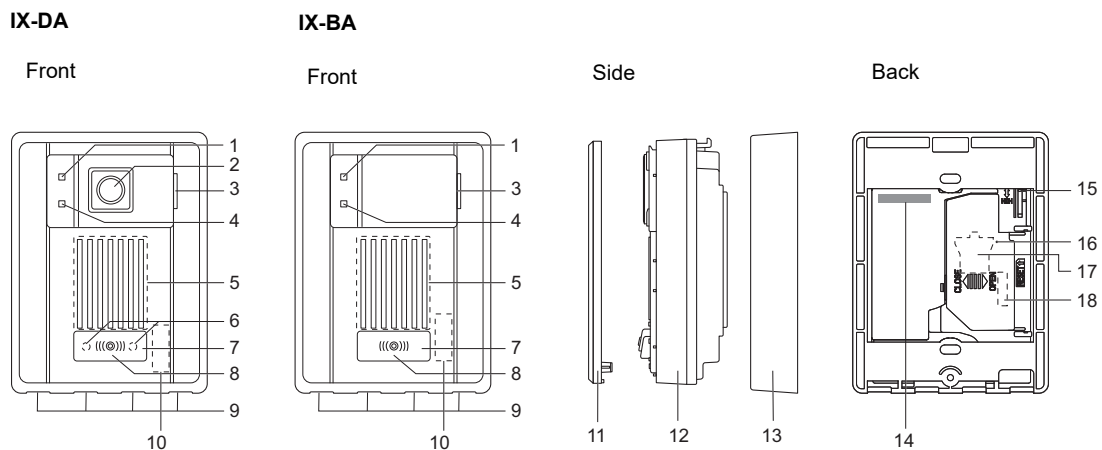

| | | | |
|---|---------------------------------|----|--|
| 1 | Call indicator (Orange) | 10 | MAC address (beneath the panel) |
| 2 | Camera | 11 | Panel |
| 3 | Microphone | 12 | Main unit |
| 4 | Communication indicator (Green) | 13 | Mounting frame |
| 5 | Speaker | 14 | MAC address |
| 6 | LED for night illumination | 15 | Camera angle adjustment lever (IX-DA only) |
| 7 | Call Button | 16 | Reset button ^{*1*2} |
| 8 | Status indicator (Red) | 17 | LAN port ^{*1} |
| 9 | Drain holes (4) | 18 | Connectors ^{*1} |

*1 Found by opening terminal cover.

*2 Press and hold the reset button for 1 - 4 seconds, then release to restart station.

■ Indicators

☒: ON, ☐: OFF

| Name | Status (pattern) | Description |
|------------------|---|---------------------------|
| Status indicator | Red flashing ☒-0.75sec → ☐0.75sec | Booting |
| | ☒-0.25sec → ☐0.25sec | Device error |
| | ☒-0.5sec → ☐4sec | Communication failure |
| | ☒-1sec → ☐0.25sec → ☒-0.25sec → ☐0.25sec → ☒-0.25sec → ☐0.25sec | Firmware version updating |
| | ☒-1sec → ☐0.25sec → ☒-0.25sec → ☐0.25sec | Initializing |
| | Red light ☒ | Standby |



Note

- For a status other than those noted here, refer to "Operation Manual."

4.7 Video Door Station (IX-DV, IX-DVF(-*)) /Door Stations (IX-SSA(-*))

■ Part names

IX-DV

Front

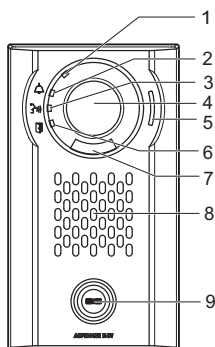

Back

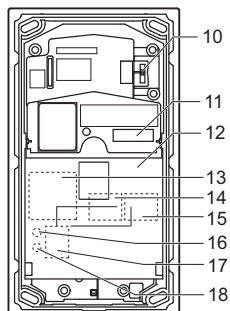

IX-DVF

Front

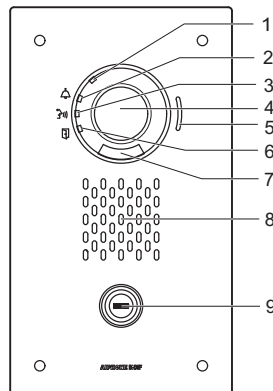

Back

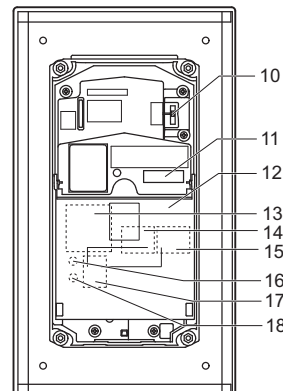

| | | | |
|---|--|----|-------------------------------|
| 1 | Status indicator (Orange/Blue) | 10 | Camera angle adjustment lever |
| 2 | Call indicator (Green) | 11 | MAC address |
| 3 | Communication indicator (Orange) | 12 | Terminal cover |
| 4 | Camera | 13 | Option connector terminal*1 |
| 5 | Microphone | 14 | LAN2 terminal (PoE/PSE)*1 |
| 6 | Door release indicator (Green) | 15 | LAN1 terminal (PoE/PD)*1 |
| 7 | LED for night illumination | 16 | Reset button*1*2 |
| 8 | Speaker | 17 | microSD card slot*1 |
| 9 | Call Button Surrounding area is lit up with blue light. | 18 | microSD card release button*1 |

*1 Accessible when terminal cover is opened.

*2 Press and hold the reset button for 1 - 4 seconds, then release to restart station.

IX-DVF-2RA

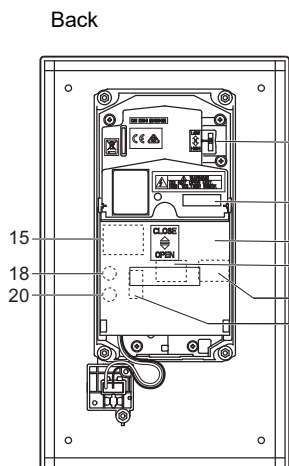
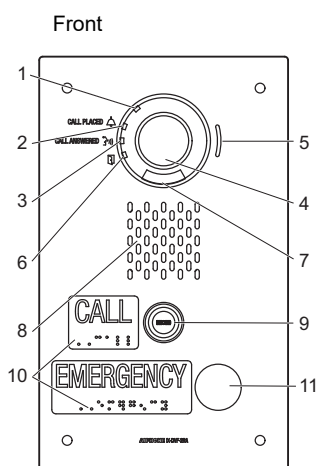

IX-DVF-RA

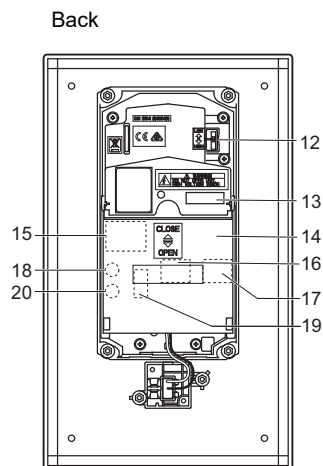
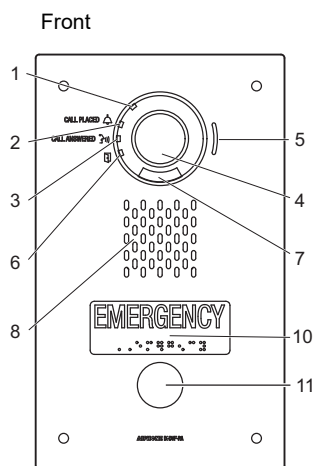

| | | | |
|----|--|----|-------------------------------|
| 1 | Status indicator (Orange/Blue) | 11 | Urgent call button |
| 2 | Call indicator (Green) | 12 | Camera angle adjustment lever |
| 3 | Communication indicator (Orange) | 13 | MAC address |
| 4 | Camera | 14 | Terminal cover |
| 5 | Microphone | 15 | Option connector terminal*1 |
| 6 | Door release indicator (Green) | 16 | LAN2 terminal (PoE/PSE)*1 |
| 7 | LED for night illumination | 17 | LAN1 terminal (PoE/PD)*1 |
| 8 | Speaker | 18 | Reset button*1*2 |
| 9 | Call Button Surrounding area is lit up with blue light. | 19 | microSD card slot*1 |
| 10 | Braille | 20 | microSD card release button*1 |

*1 Found by opening terminal cover.

*2 Press and hold the reset button for 1 - 4 seconds, then release to restart station.

IX-DVF-P

Front

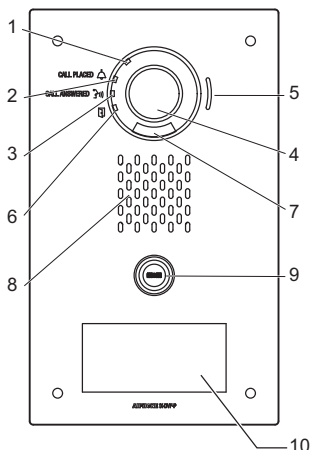

Back

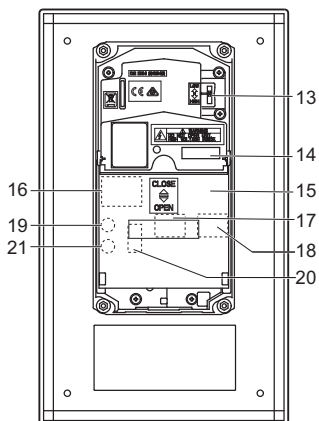

IX-DVF-L

Front

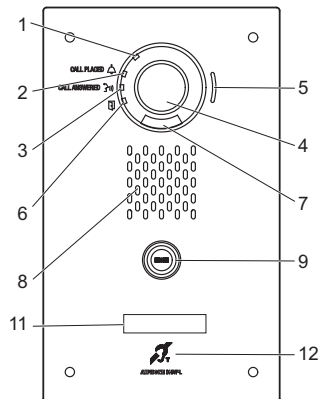

Back

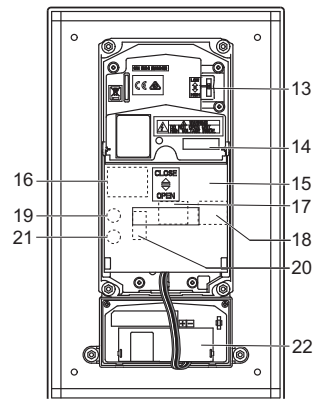

| | | | |
|----|--|----|--|
| 1 | Status indicator (Orange/Blue) | 12 | Hearing aid (T mode) compatible microphone |
| 2 | Call indicator (Green) | 13 | Camera angle adjustment lever |
| 3 | Communication indicator (Orange) | 14 | MAC address |
| 4 | Camera | 15 | Terminal cover |
| 5 | Microphone | 16 | Option connector terminal*1 |
| 6 | Door release indicator (Green) | 17 | LAN2 terminal (PoE/PSE)*1 |
| 7 | LED for night illumination | 18 | LAN1 terminal (PoE/PD)*1 |
| 8 | Speaker | 19 | Reset button*1*2 |
| 9 | Call Button Surrounding area is lit up with blue light. | 20 | microSD card slot*1 |
| 10 | HID reader | 21 | microSD card release button*1 |
| 11 | Nameplate (with backlight) | 22 | Hearing aid unit |

*1 Found by opening terminal cover.

*2 Press and hold the reset button for 1 - 4 seconds, then release to restart station.

IX-SSA

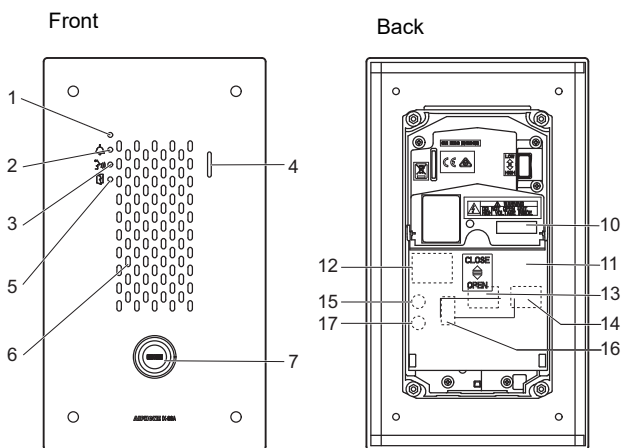

IX-SSA-2RA

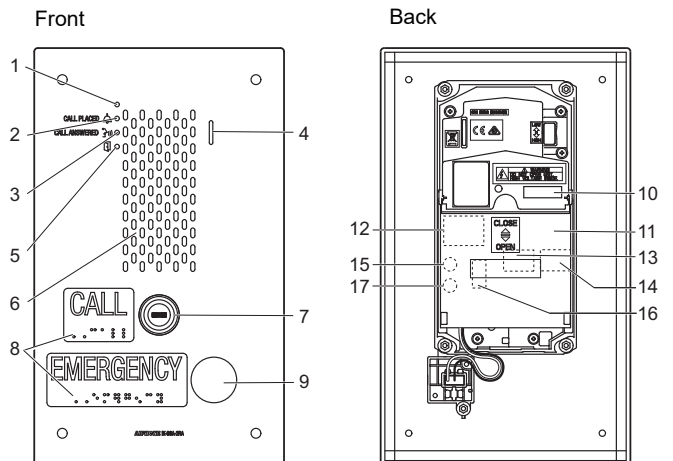

IX-SSA-RA

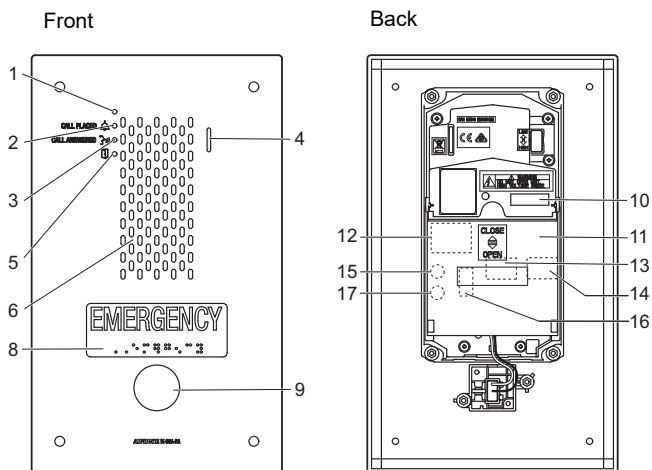























| | | | |
|---|--|----|-------------------------------|
| 1 | Status indicator (Orange/Blue) | 10 | MAC address |
| 2 | Call indicator (Green) | 11 | Terminal cover |
| 3 | Communication indicator (Orange) | 12 | Option connector terminal*1 |
| 4 | Microphone | 13 | LAN2 terminal (PoE/PSE)*1 |
| 5 | Door release indicator (Green) | 14 | LAN1 terminal (PoE/PD)*1 |
| 6 | Speaker | 15 | Reset button*1*2 |
| 7 | Call Button Surrounding area is lit up with blue light. | 16 | microSD card slot*1 |
| 8 | Braille | 17 | microSD card release button*1 |
| 9 | Urgent call button | | |

*1 Found by opening terminal cover.

*2 Press and hold the reset button for 1 - 4 seconds, then release to restart station.

■ Indicators

: ON, : OFF

| Name | Status (pattern) | | Description |
|------------------|------------------|--|----------------------------------|
| Status indicator | Orange flashing |  0.75sec →  0.75sec | Booting |
| | |  0.25sec →  0.25sec | Device error, Startup error |
| | |  0.5sec →  4sec | Communication failure |
| | |  1sec →  0.25sec →  0.25sec →  0.25sec →  0.25sec →  0.25sec | Firmware version updating |
| | |  2sec →  0.25sec →  0.25sec →  0.25sec | Mounting/unmounting microSD card |
| | |  1sec →  0.25sec →  0.25sec →  0.25sec | Initializing |
| | Blue light |  | Standby |



Note

- For a status other than those noted here, refer to "Operation Manual."

4.8 Lift Control Adaptor (IXGW-LC)

■ Part names

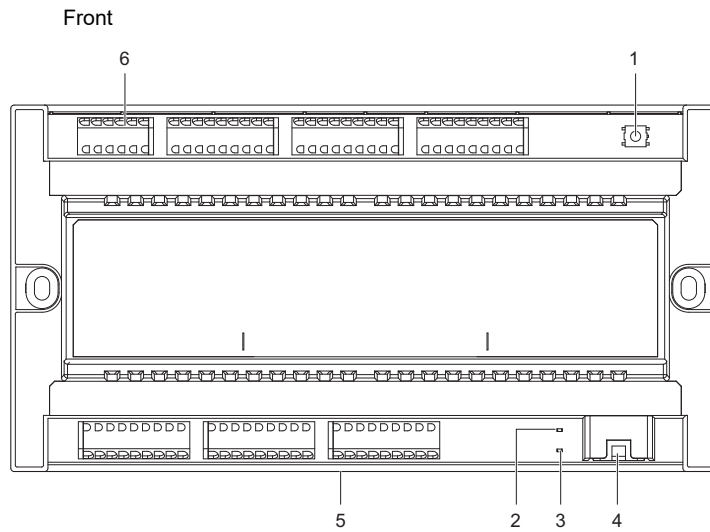



| | | | |
|---|---------------------------|---|---------------------------------|
| 1 | Reset button*1 | 4 | LAN (PoE) port |
| 2 | Status indicator (Orange) | 5 | Lock release lever (Back) |
| 3 | Status indicator (Green) | 6 | Low-voltage connection terminal |

*1 Press and hold the reset button for 1 - 4 seconds, then release to restart station.

*2 The MAC address is found on the back on the device.

■ Indicators

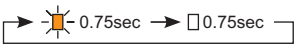
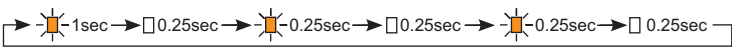
☀: ON, □ : OFF

| Name | Status (pattern) | | Description |
|------------------|------------------|--|---------------------------|
| Status indicator | Orange flashing |  | Booting |
| | |  | Firmware version updating |
| | |  | Initializing |
| | Green light |  | Standby |

4.9 Gateway Adaptor (IXGW-GW)

■ Part names

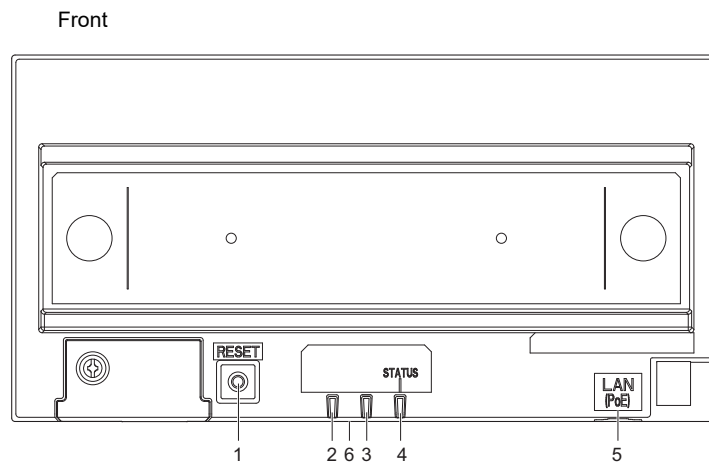

| | | | |
|---|--------------|---|---------------------------------|
| 1 | Reset button | 4 | Status indicator (Orange/Green) |
| 2 | Not used | 5 | LAN (PoE) port |
| 3 | Not used | 6 | Lock release lever (Back) |

*1 Press and hold the reset button for 1 - 4 seconds, then release to restart station.

*2 The MAC address is found on the back on the device.

! Important

- Due to the features and services provided by the Gateway Adaptor and the AIPHONE IXG app, future required changes to device functionality, network communication, security, etc. may require firmware updates unavailable to the Gateway Adaptor. In this situation, the Gateway Adaptor would need to be replaced at the cost of the responsible party.

■ Indicators

☀: ON, □ : OFF

| Name | Status (pattern) | | Description |
|------------------|------------------|--|---------------------------------------|
| Status indicator | Orange light | ☀ | IXG Cloud Server authentication error |
| | Orange flashing | ☀ 0.75sec → □ 0.75sec | Booting |
| | | ☀ 0.5sec → □ 4sec | Communication failure |
| | | ☀ 1sec → □ 0.25sec → ☀ 0.25sec → □ 0.25sec → ☀ 0.25sec → □ 0.25sec | Firmware version updating |
| | | ☀ 1sec → □ 0.25sec → ☀ 0.25sec → □ 0.25sec | Initializing |
| Green light | ☀ | Standby | |

5. Configuring the system

The IXG System can be configured using the following methods.

- Configure the system using the "IXG Support Tool" application.
 - Install the application on a PC and use to create the configuration for all stations.
 - Search for IXG system stations on the network; assign and upload the setting file for the system.

There are two configuration modes for IXG Support Tool.

- Administrator mode: Configure all settings.
- Property Manager mode: Configure only the following settings.

Move-in Settings

- Units / Stations
- Identification
- Station List
- Mobile App List
- Network Camera List
- Group
- Called Stations (Door/Sub Stations)
- Guard Button (IXG-2C7)

Move-out Settings

- Resident Move-out
- Delete Unit Information

Misc.

- Access Code
- Welcome Screen
- Absent Transfer
- Delay Transfer
- Schedule Transfer

This document describes how to configure settings in Property Manager mode. For information on Administrator mode, refer to the separate "IXG Support Tool Setting Manual: Administrator Mode."

Important

- Be sure to store the setting file that was created. If the setting file is lost, you may be charged a separate setting fee during maintenance or post-installation maintenance and service.

6. Flowcharts for configuring the system

Follow the flowchart below when changing the settings using IXG Support Tool.

Save the settings after configuring the system. Otherwise, it may become impossible to restore the settings after maintenance or after-sales servicing.

1. Set the language.

["Language \(→page 73\)"](#)



2. Download the settings from all the stations.

["Download Settings \(→page 54\)"](#)



3. Perform setup.

Follow the instructions for each setting item and perform setup.

["System Settings \(→page 75\)"](#)

If using App Integration, configure settings following the detailed explanation in "App Integration Flowchart."

["Flowcharts for Mobile App Integration \(→page 29\)"](#)



Has the "Station Number," "Station Name," or "Camera Name" been changed?

YES



NO



4. Upload the setting data to all stations.

["Upload Settings \(→page 56\)"](#)

4. Upload the setting data to the station whose settings were changed.

["Upload Settings \(→page 56\)"](#)



5. Complete

7. Flowcharts for Mobile App Integration

! Important

- Due to the features and services provided by the Gateway Adaptor and the AIPHONE IXG app, future required changes to device functionality, network communication, security, etc. may require firmware updates unavailable to the Gateway Adaptor. In this situation, the Gateway Adaptor would need to be replaced at the cost of the responsible party.
- QR code is a registered trademark of Denso Wave Incorporated.

7.1 Registering the Mobile App

The flowchart below describes the process of registering a Mobile App with a new or existing site.

1. Register the App in [“Units / Stations \(→page 76\)”](#).



2. Configure the following settings.

- Test Settings* [“IXG Support Tool Settings \(→page 49\)”](#)
- Change password at initial login [“App Integration \(→page 60\)”](#)
- Unit Name* [“Units / Stations \(→page 76\)”](#)
- Station Name [“Identification \(→page 79\)”](#)
- Open Station List [“Station List \(→page 81\)”](#)
- Create mobile app list [“Mobile App List \(→page 84\)”](#)

* Configuration is not required if it is already registered.



3. Updating the Settings to an Existing Site on the IXG Cloud Server.

[“Uploading an existing site to the IXG Cloud Server \(→page 61\)”](#)



4. Generate PDF of QR Code for App Registration.

[“Export QR Code for App Registration \(→page 65\)”](#)

* If there is already a Tenant Station in the unit, send the QR Code to the Tenant Station.

[“Applying QR Code for App Registration to a station \(→page 64\)”](#)





5. Upload the setting file to the station.

[“Upload Settings \(→page 56\)”](#)



6. Register the Mobile App by scanning the QR code.

7.2 Adding a Mobile App to Each Unit

The flowchart below describes the process of registering a Mobile App with a unit that is already connected to the IXG Cloud Server.

Important

- Refer to [“Registering the Mobile App \(→page 29\)”](#) for information on registering the first Mobile App in each unit.

1. Add the "App" in [“Units / Stations \(→page 76\)”](#).



2. Configure the following settings.

- Station Name [“Identification \(→page 79\)”](#)
- Open Station List [“Station List \(→page 81\)”](#)



3. Updating the Settings to an Existing Site on the IXG Cloud Server.

[“Uploading an existing site to the IXG Cloud Server \(→page 61\)”](#)



4. Generate PDF of QR Code for App Registration.

[“Export QR Code for App Registration \(→page 65\)”](#)



5. Upload the setting file to the station.

[“Upload Settings \(→page 56\)”](#)



6. Register the Mobile App by scanning QR code.

* For a residential Mobile App where a Tenant Station is installed in the residence, touch **[SETTINGS] - [Register Apps]** on the Home Screen of the Tenant Station to display the QR code.

7.3 When the type of mobile device registered to a Residential unit was replaced

The flowchart below describes the process of replacing a Mobile App.

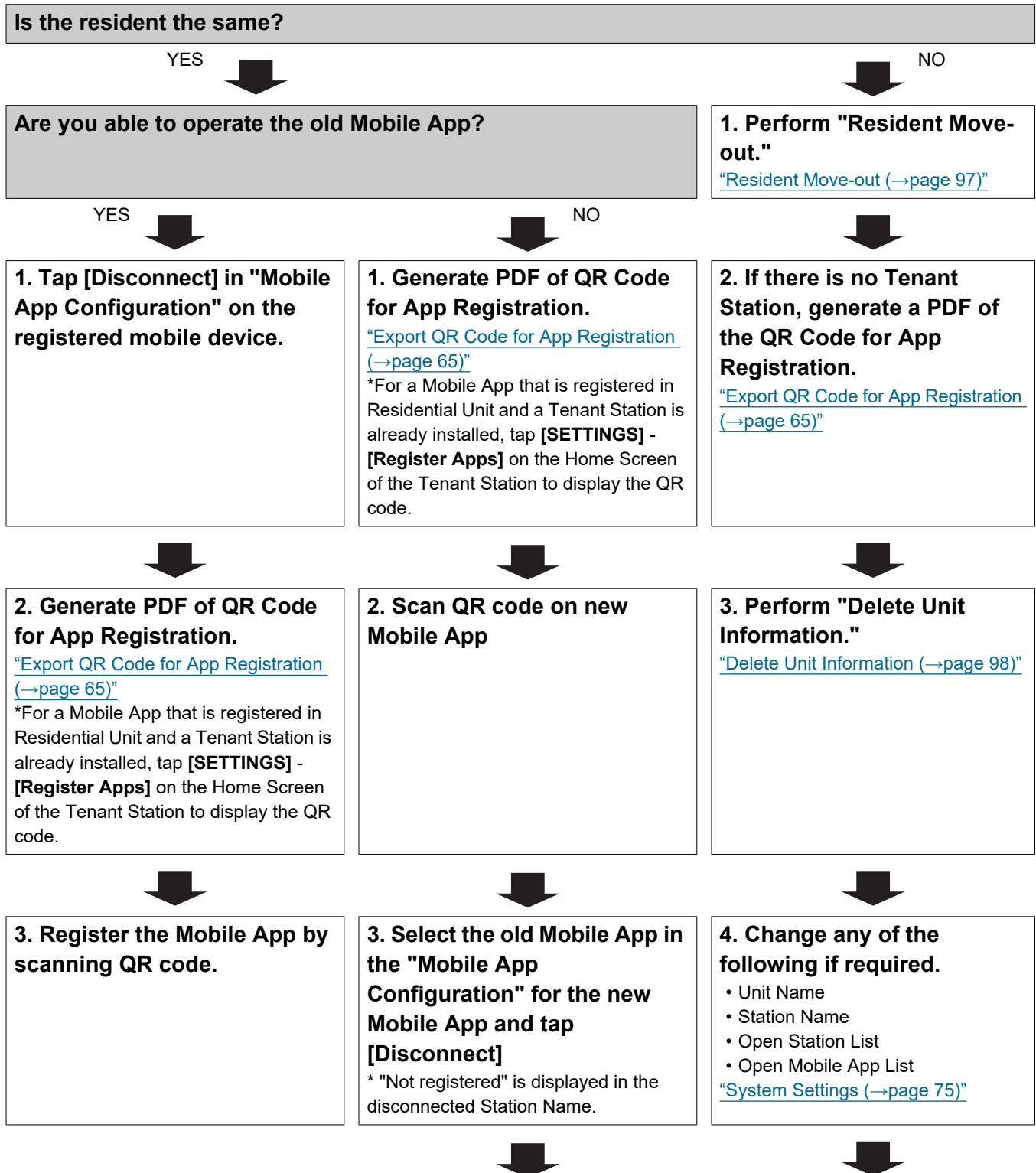



4. Tap the disconnected Station Name in the "Mobile App Configuration" for the new Mobile App and tap [Connect]



5. Upload the settings to the IXG Cloud Server.
["Uploading an existing site to the IXG Cloud Server \(→page 61\)"](#)



6. Upload the setting file to the station.
["Upload Settings \(→page 56\)"](#)



7. Register the new Mobile App by scanning the QR code.

7.4 When the type of mobile device registered to a Guard or a Commercial unit was replaced

The flowchart below describes the process of replacing a Mobile App.

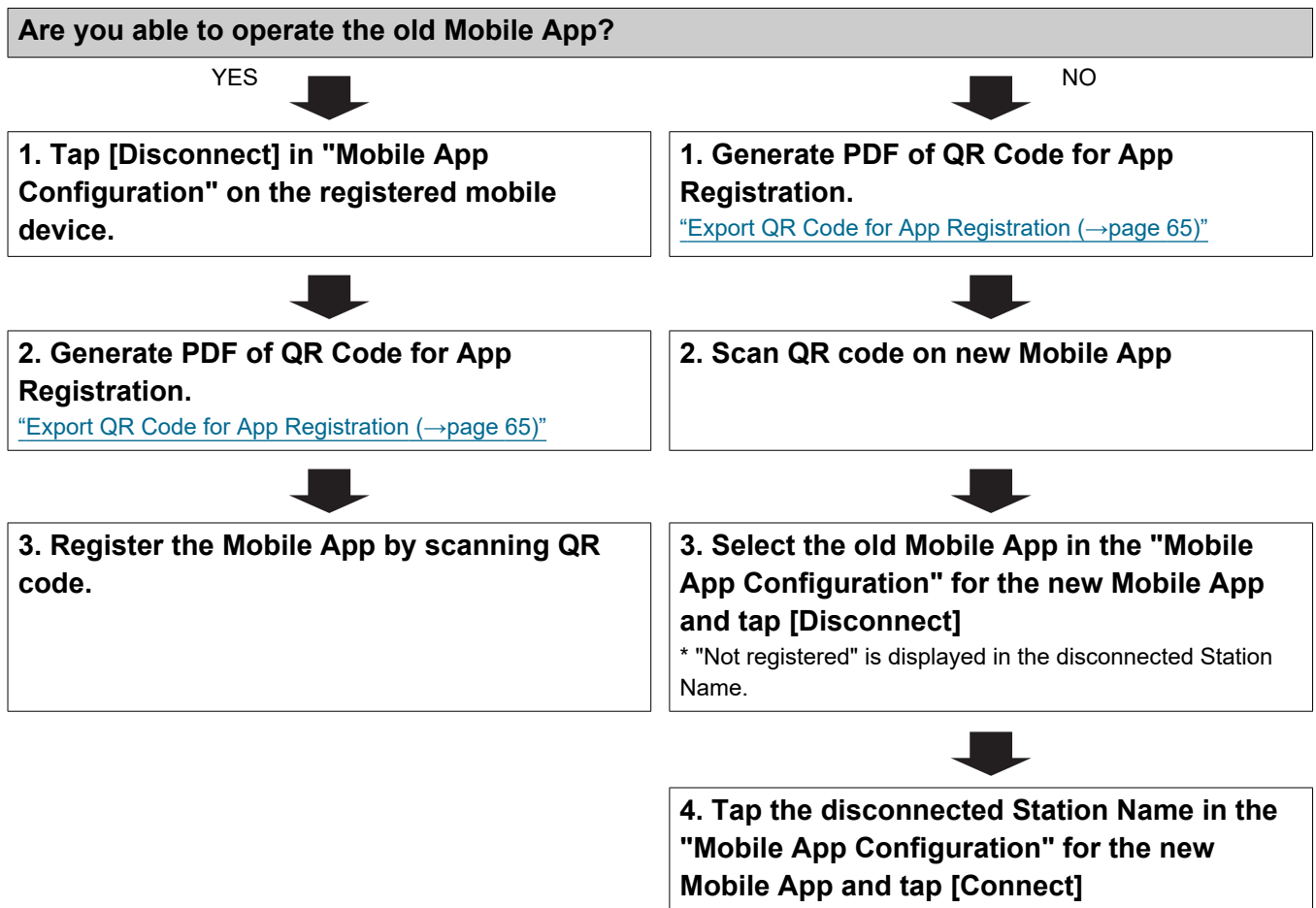

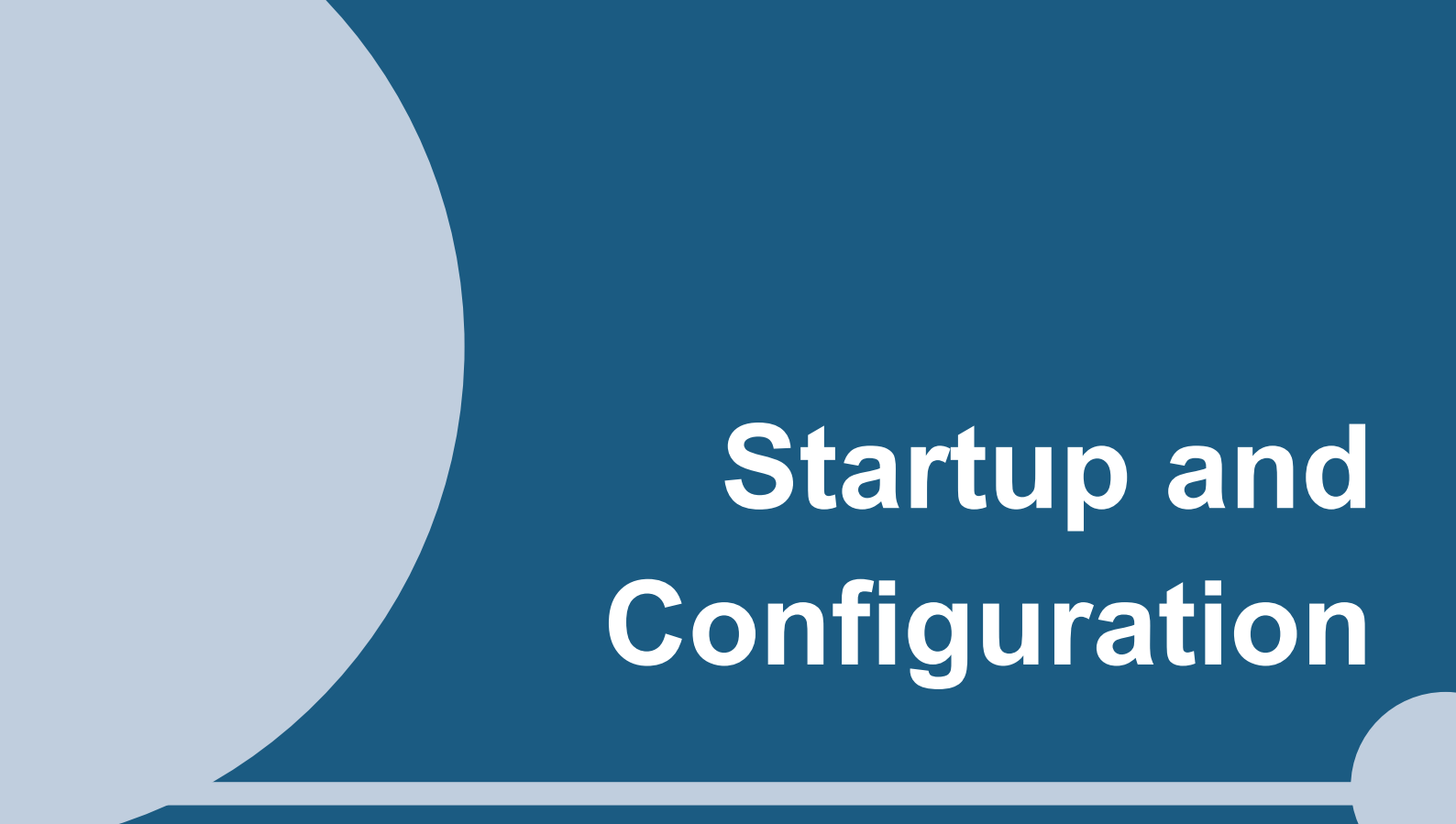

Startup and Configuration

1. System requirements

PC requirements for using the IXG Support Tool.

| | |
|------------------|--|
| Operating System | Windows 7 Professional (SP1), Windows 7 Enterprise (SP1), Windows 7 Ultimate (SP1) Windows 8, Windows 8 pro, Windows 8 Enterprise Windows 8.1, Windows 8.1 pro, Windows 8.1 Enterprise Windows 10 Home, Windows 10 Pro, Windows 10 Enterprise |
| CPU | 32 bit (x86) processor or 64 bit (x64) processor of 1 GHz or higher |
| Memory | 4 GB RAM or higher |
| Resolution | 1280x768 or greater |



Note

- Set the display size setting of your PC to “100%”.
If set to a setting other than “100%”, the screen of the IXG Support Tool may not be displayed correctly.

2. Installing IXG Support Tool

1. Access our Web site at <https://www.aiphone.net/product/support/> and download the IXG Support Tool to your PC.
2. Double-click the downloaded file ("AIPHONE_IXG_SupportTool_Setup.exe") to install IXG Support Tool.

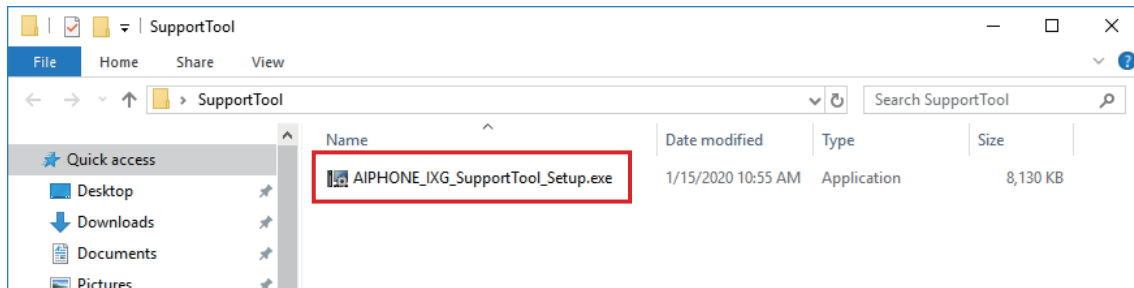

3. Select the components to install for IXG Support Tool, and then click **[Next]**.

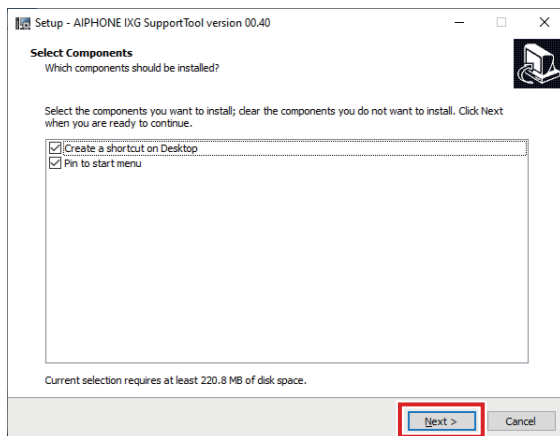

4. Click **[Finish]**.

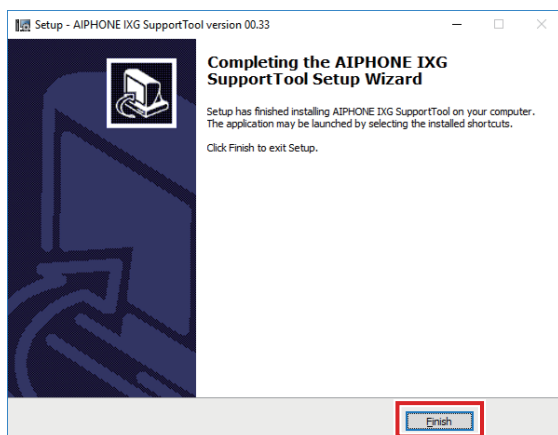

- IXG Support Tool is now installed.

3. Login and registration of the station

1. Double-click any of the following.
 - The "AIPHONE IXG SupportTool" shortcut that was created on the desktop
 - "AIPHONE IXG SupportTool" in the Start Menu
 - "Local Disk (C)" - "Program Files" - "Aiphone" - "IXG" - "SupportTool" - "AIPHONE_IXG_SupportTool.exe"

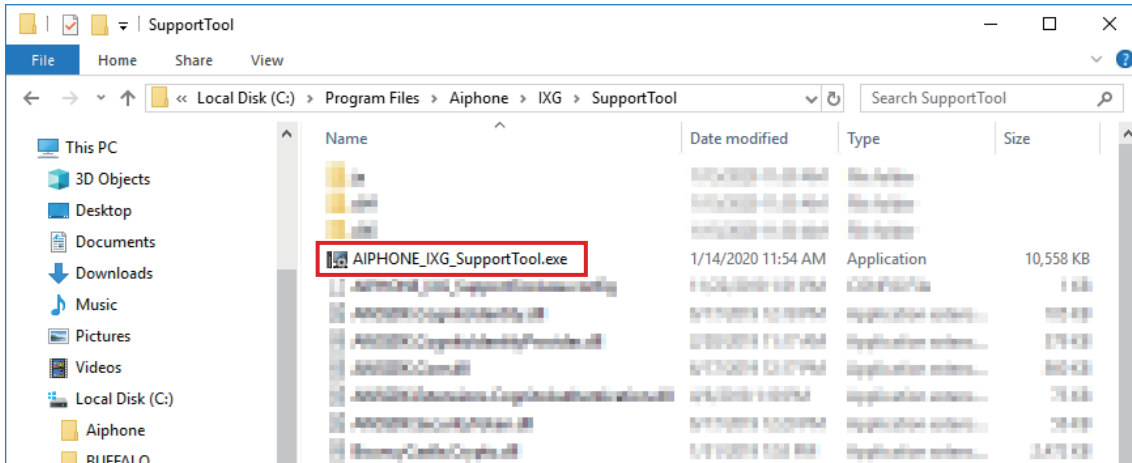

2. Select "Property Manager."
 - For information on Administrator mode, refer to the separate "IXG Support Tool Setting Manual: Administrator Mode."

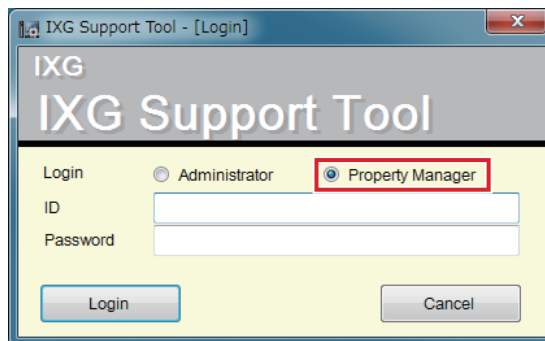

3. Enter "ID" and "Password," and click [Login].
 - The "Property Manager Settings" screen is displayed.
 - The setting data configured during the previous login session will be shown.
 - The default ID and Password are "admin."

4. How to Configure

After logging into IXG Support Tool, the Settings screen is displayed. The Settings screen is used to configure settings.

- Depending on PC and OS being used, the window may be slightly different.
- After configuration, refer to the "Operation Manual" for each station and confirm operation.

4.1 Settings window

Settings screen sample

All stations in the system can be configured using the table.

Update: Click to save the settings.

Menu bar: Allows you to create new setting data. "[Menu bar](#) ([→page 44](#))"

Information: Click to display notes.

Title bar: Displays the system name and title when editing settings.

| Building Number | Unit Number | Station Name | System Information | | | | System Information | | |
|-----------------|-------------|-----------------|--------------------|-----------------|----------------|-------|--|-----------------------------------|-------------|
| | | | Group | | | | Group | | |
| | | | 01 | | | | 01 | | |
| | | | Number | Name | Type | Total | Station Number / Station Name / Station Type | | |
| 01 | 002 | Master Station1 | 01 | Inside Area 002 | Audio Protocol | 1 | 0010 / Entrance Station1 / IXG-DM7(-*) | 0020 / Master Station1 / IX-MV7-* | 0021 / Mast |
| | | | | | Video Protocol | 1 | | | |
| 01 | 002 | Master Station2 | 01 | Inside Area 002 | Audio Protocol | 1 | | U | |
| | | | | | Video Protocol | 1 | | U | |
| 01 | 106 | Master Station1 | 01 | Inside Area 002 | Audio Protocol | 2 | | U | U |
| | | | | | Video Protocol | 2 | | U | U |

Settings menu: Displays a list of titles. When you click a title that you want to configure, the corresponding Settings screen is displayed.

Settings screen: The Settings screen for the currently selected title is displayed.

Note

- Settings which cannot be modified will be grayed out.

4.2 How to Configure

1. Click the title to be configured.
 - The Settings window for that particular title will be shown.
2. Enter setting values for each entry.
 - The selected field will turn orange.
 - When changing the settings, the field will turn pink.
 - Some titles allow copy and paste.

| Building Number | Unit Number | Station Type | Station Settings | |
|-----------------|-------------|--------------|------------------|-------------------|
| | | | Identification | |
| | | | Station Number | Station Name |
| 01 | 001 | IXG-DM7(-*) | 0010 | Entrance Station1 |
| 01 | 002 | IX-MV7-* | 0020 | Master Station3 |
| 01 | 002 | IX-MV7-* | 0021 | Master Station2 |

! Important

- Be sure to input the settings for entries in red. Use the default values, unless a change is necessary.

- Select an entry field and press the F1 key to display an explanation screen.

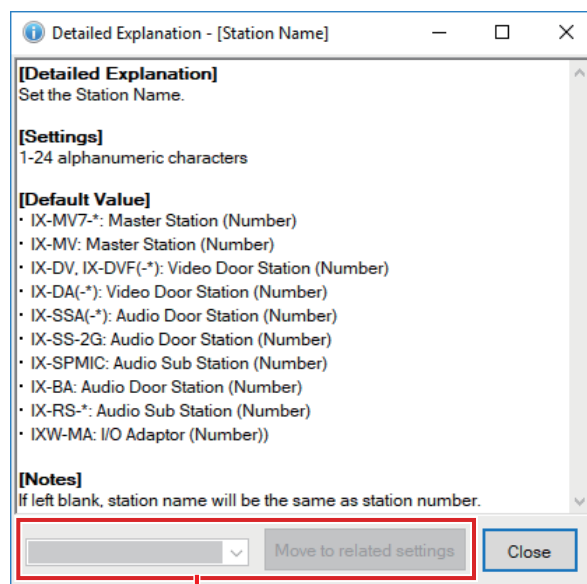

Move to related item: This allows you to move to the Settings screen for related entries.

- Pressing [Ctrl] + [F] displays the Search window, which allows the search function to be used. Enter the text to search and click **[Find Next]** to move to the applicable cell.
-  is displayed when the cursor is moved over an entry. Clicking this allows you to use the filter function. Select what to display and then click **[Apply]** to display only the applicable information.

| Building Number | Unit Number | Station Type | Station Settings | |
|-----------------|-------------|--------------|------------------|-----------------|
| | | | Identification | |
| | | | Station Number | Station Name |
| 01 | 001 | | | |
| 01 | 002 | | | |
| 01 | 002 | | | |
| 01 | 003 | | | |
| 01 | 101 | | | |
| 01 | 101 | | | |
| 01 | 101 | | | |
| 01 | 102 | IXG-2C7(-*) | 1020 | Tenant Station1 |

(Select All)

Intercom App

IX-DV,IX-DVF(-*)

IXG-2C7(-*)

IXG-DM7(-*)

IXGW-GW

IXGW-LC

IX-MV7-*

B Text Filter
 Apply Clear Cancel

3. When you are done configuring on this screen, click **[Update]** to save the settings.

- To cancel all settings, click another title in the Setting menu.
- If there is an error when clicking **[Update]**, the error message will be shown and the settings will not be allowed to be saved.

The field will be shown in red if there is an error in the settings.

| Building Number | Unit Number | Station Type | Station Settings | |
|-----------------|-------------|------------------|------------------|---------------------|
| | | | Identification | |
| | | | Station Number | Station Name |
| 01 | 001 | IXG-DM7(-*) | 0010 | Entrance Station1 |
| 01 | 002 | IX-MV7-* | 0020 | Master Station_1 |
| 01 | 002 | IX-MV7-* | 0021 | Master Station2 |
| 01 | 002 | IX-DV,IX-DVF(-*) | 0022 | Video Door Station1 |

Required settings.

- If another title is selected without clicking **[Update]**, the system will prompt whether to save the settings. Click **[Yes]** to save, or click **[No]** to display another title without saving.
- Click **[Cancel]** to return to the previous screen.

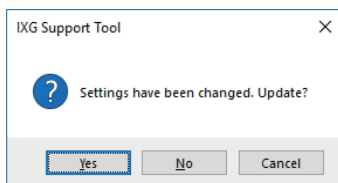

4. Perform Steps 1 - 3 for other titles as well.

5. System settings list

The following items can be configured using IXG Support Tool.

The symbols indicate the following:

- ◆: Be sure to enter a setting value. Use the default values, unless a change is necessary.
- ♣: The setting item information can be copied.
 - The following table provides an overview of IXG Support Tool. The content, how they are displayed, and the order of entries may vary from the actual screens.
 - Download and back up the setting file "[Exporting the IXG Support Tool System Configuration \(→page 47\)](#)" in case post-installation maintenance and service is required, and store it in a safe place where it will not be lost. If a backup has not been performed, it may not be possible to recover the data during after-sales service.

| Setting items | | | | Reference pages |
|---|-------------------------|---|---|-----------------|
| Site Settings (Move-in Settings) | | | | |
| Units / Stations | - | - | Unit Name◆ | 77 |
| | | | First Name (Residential only) | 78 |
| | | | Last Name (Residential only) | 78 |
| | | | App (Guard, Commercial, Residential only) | 78 |
| Station Information (Move-in Settings) | | | | |
| Identification | - | - | Station Number◆ | 79 |
| | | | Station Name◆ | 80 |
| System Information (Move-in Settings) | | | | |
| Station List | - | - | - | 81 |
| Mobile App List | - | - | - | 84 |
| Network Camera List | Network Camera Registry | - | Camera Name◆ | 87 |
| | | | Hostname | 88 |
| | | | IP Address (IPv4)◆ | 88 |
| | | | IP Address (IPv6)◆ | 88 |
| | | | ID◆ | 88 |
| | | | Password◆ | 88 |
| Group | Configuring a Group | - | - | 91 |
| Call Settings (Move-in Settings) | | | | |
| Called Stations (Door/Sub Stations) | - | - | - | 93 |
| Guard Button (IXG-2C7) | - | - | Select Station | 96 |
| | | | Mobile App | 96 |

| Setting items | | | | Reference pages |
|--|--------------------------|-----|---------------------------|-----------------|
| Move-out Settings (Move-out Settings) | | | | |
| Resident Move-out | - | - | - | 97 |
| Delete Unit Information | - | - | - | 98 |
| Entrance Station Settings (Misc.) | | | | |
| Access Code | Add Access Code | - | - | 101 |
| | Delete Access Code | - | - | 102 |
| Welcome Screen | Welcome Screen Wallpaper | - | - | 103 |
| | Image 1 | - | Display | 104 |
| | | | File name | 104 |
| Transfer Settings (Misc.) | | | | |
| Absent Transfer | - | - | Absent Transfer | 105 |
| | | | Transfer Destination List | 108 |
| | | | Re-Transfer Destination | 114 |
| Delay Transfer | - | - | Delay Transfer | 107 |
| | | | Delay Time [sec]↕ | 107 |
| | | | Transfer Destination List | 108 |
| | | | Re-Transfer Destination | 108 |
| Schedule Transfer | - | - | Schedule Transfer | 109 |
| | | | Weekly Schedule | - |
| | Re-Transfer Destination | 110 | | |
| | Start Time | 111 | | |
| | End Time | 111 | | |
| | Daily Schedule | - | Transfer Destination List | 113 |
| | | | Re-Transfer Destination | 114 |
| | | | Start Time | 114 |
| End Time | | | 114 | |

Menu bar

Important

- The symbols indicate the following:
 - ◆: Be sure to enter a setting value. Use the default values, unless a change is necessary.

1. File

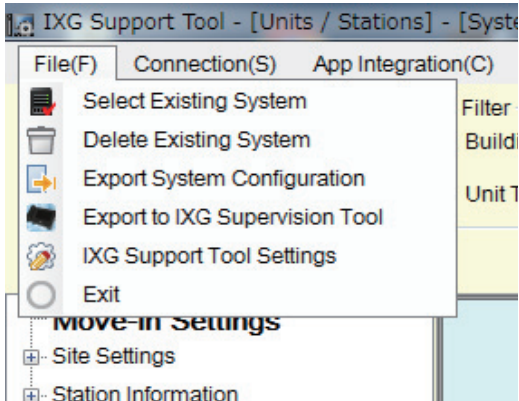

1.1 Select Existing System

Edit a setting file that already exists. This allows you to load a setting file that was saved. Select "File" - "Select Existing System." The "System Selection" screen will be displayed.

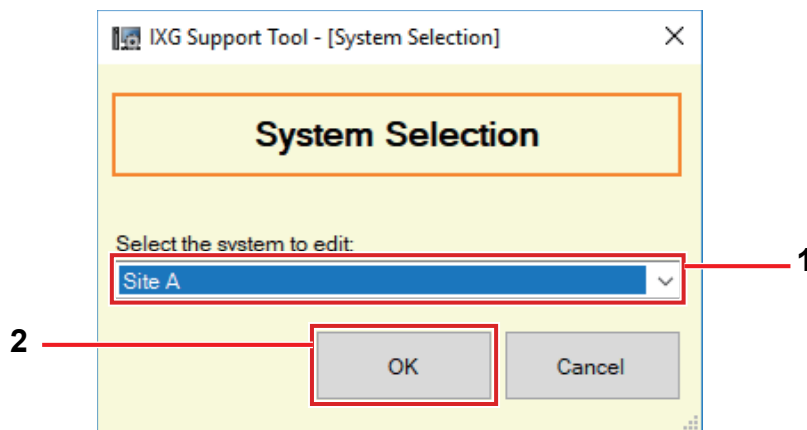

1. Select the system (site name) for the setting file to edit.
2. Click **[OK]**.
 - In the Setting window, the selected setting data will be shown.
 - Click **[Cancel]** to quit without selecting a system.

1.2 Delete Existing System

Delete created setting data.

Select "File" - "Delete Existing System." The "Delete System" screen is displayed.

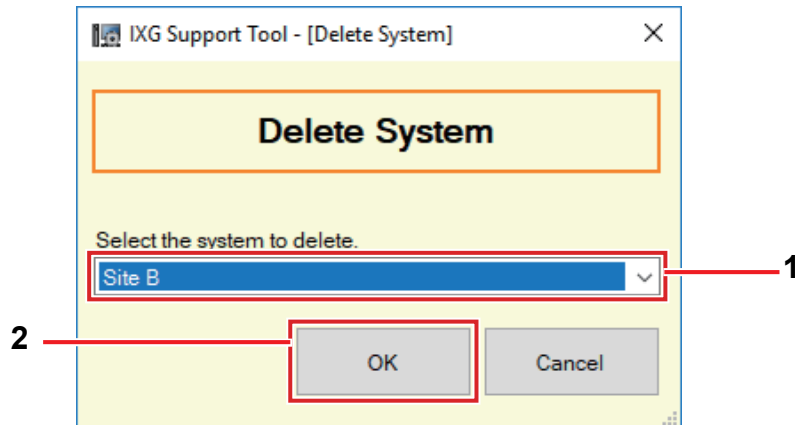

1. Select the system (site name) for the setting file to delete.
2. Click **[OK]**.
 - Delete the selected setting data.
 - Click **[Cancel]** to quit without deleting a system.
3. Click **[OK]**.
 - Click **[Cancel]** to return to the "Delete System" screen.

1.3 Exporting the IXG Support Tool System Configuration

Backup setting files created in IXG Support Tool.

If the settings are lost, it may be impossible to restore them after maintenance or after-sales servicing.

Select "File" - "Export System Configuration." The "Export Settings" screen is displayed.

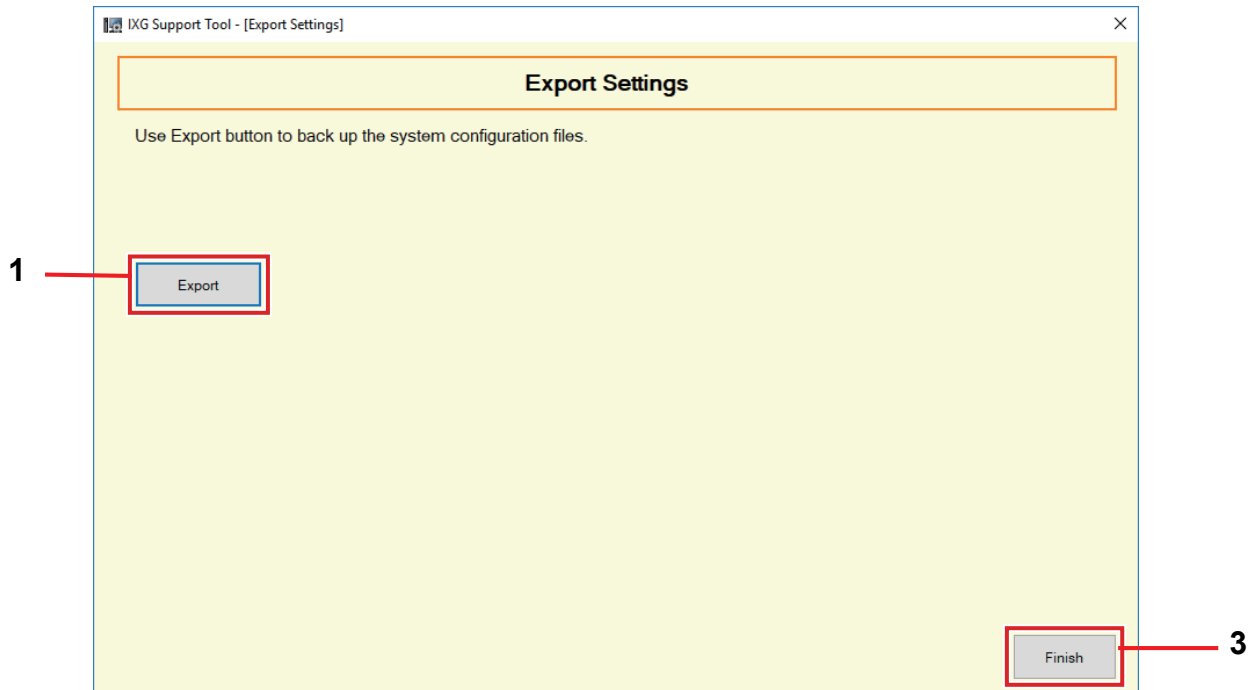

1. Click **[Export]**.
2. Select the folder where the setting file is saved and click **[OK]**.
 - A folder with the name specified in "Site Name" will be created in the specified directory, and the system configuration file will be saved inside as a hidden file.
Copy the entire "Site Name" folder to store the setting file.
 - Click **[Cancel]** to return to the "Export Settings" screen without saving the setting file.
3. Click **[Finish]**.

1.4 Outputting IXG Supervision Tool Data

To use registered station information with the IXG Supervision Tool, output the file in Address Book format. Select "File" - "Export to IXG Supervision Tool" to display the following screen.



1. Click **[Browse]** and select the folder where the setting file will be saved.
2. Click **[Export]**.
3. Click **[OK]**.
 - The setting file will be saved as "SettingAddressList.txt."
 - Information for stations without configured IP addresses will not be output.

1.5 IXG Support Tool Settings

Select "File" - "IXG Support Tool Settings." The "IXG Support Tool Settings" screen will be displayed.

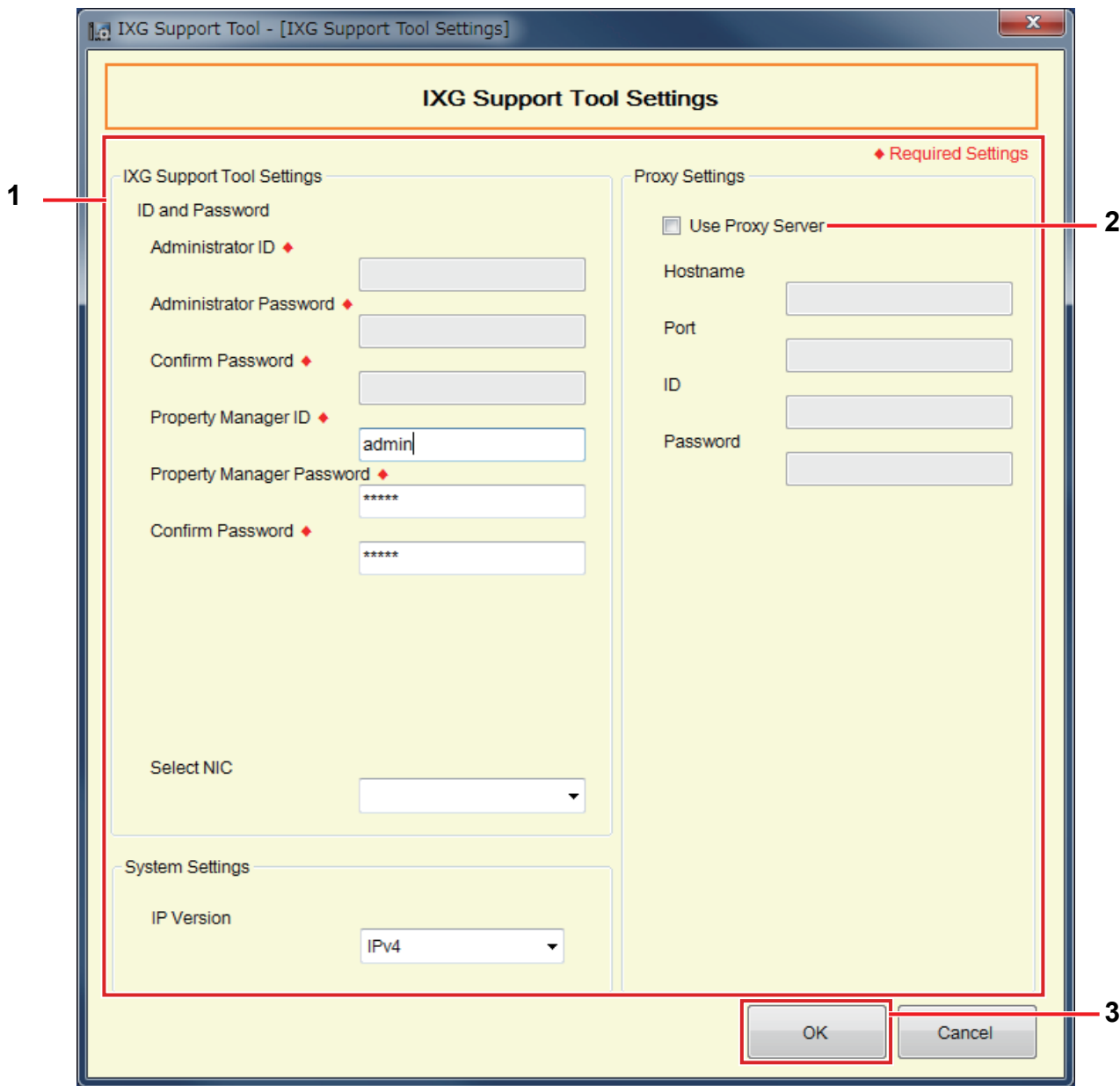

How to configure IXG Support Tool Settings

1. Configure each item.
2. If a proxy server is used to access the IXG Cloud Server, check the "Use Proxy Server" box and enter the required information.
3. Click [OK].
 - Click [Cancel] to exit.

■ Administrator ID◆

| | |
|-------------|----------|
| Description | Not used |
|-------------|----------|

■ Administrator Password◆

| | |
|-------------|----------|
| Description | Not used |
|-------------|----------|

■ Confirm Password◆

| | |
|-------------|----------|
| Description | Not used |
|-------------|----------|

■ Property Manager ID◆

| | |
|---------------|--|
| Description | Configure the ID used to login to IXG Support Tool in Property Manager mode. |
| Settings | 1-32 alphanumeric characters |
| Default value | admin |

■ Property Manager Password◆

| | |
|---------------|--|
| Description | Configure the password used to login to IXG Support Tool in Property Manager mode. |
| Settings | 1-32 alphanumeric characters |
| Default value | admin |

■ Confirm Password◆

| | |
|---------------|--|
| Description | Enter the "Property Manager Password" again. |
| Settings | 1-32 alphanumeric characters |
| Default value | admin |

■ Select NIC

| | |
|---------------|--|
| Description | Select the network interface card (NIC). |
| Settings | Select the NIC used for the PC. |
| Default value | - |

■ IP Version

| | |
|---------------|--|
| Description | Choose the protocol for IXG Support Tool. |
| Settings | <ul style="list-style-type: none"> • IPv4 • IPv6 |
| Default value | IPv4 |

■ Hostname

| | |
|---------------|---|
| Description | Enter the IP address of the proxy server. |
| Settings | 1-255 alphanumeric characters |
| Default value | - |

■ Port

| | |
|---------------|--|
| Description | Enter the port number of the proxy server. |
| Settings | 1-5 digits |
| Default value | - |

■ ID

| | |
|---------------|---|
| Description | Enter the ID used for proxy authentication. |
| Settings | 1-255 alphanumeric characters |
| Default value | - |

■ Password

| | |
|---------------|---|
| Description | Enter the password used for proxy authentication. |
| Settings | 1-255 alphanumeric characters |
| Default value | - |

1.6 Exit

Select "File" - "Exit" to close IXG Support Tool.

2. Connection

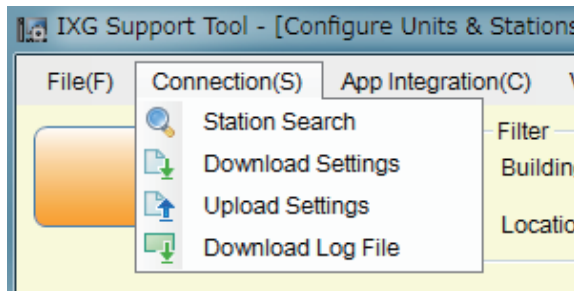

2.1 Station Search

Search the stations in IXG and IX Systems connected in the network to show the list.

1. Connect the PC to a network on the same segment as the system.
 - Set this to the same IP version as the system. Refer to [“IXG Support Tool Settings \(→page 49\)”](#) for information of configuring the IP version.
2. Select "Connection" - "Station Search". The stations searched are displayed on the "Station Search" screen. (Searching may take several minutes.)
 - The stations without power and the stations in the process of initialization will not be subject to search.
 - Search up to 9999 stations at a time.
 - Stations on other segments cannot be searched.
 - Click **[Search]** to search again.

Station Search

Search results within the local network.

| Station List | | | | | | | Required settings. |
|-----------------|-------------|---------------------|------------------|--------------|-------------------|------------------|------------------------------------|
| Building Number | Unit Number | Station Name | Station Type | IP Address | MAC Address | Firmware Version | Sub Firmware Version (for IXG-DM7) |
| | | Gateway Adaptor1 | IXGW-GW | 192.168.1.41 | 00:0B:AA:44:00:1A | 0.19 | |
| 01 | 101 | Video Door Station1 | IX-DV,IX-DVF(-*) | 192.168.1.17 | 00:0B:AA:27:00:3A | C.05 | |
| 01 | 101 | Tenant Station1 | IXG-2C7(-*) | 192.168.1.15 | 00:0B:AA:3C:00:57 | 0.73 | |
| 01 | 101 | Tenant Station2 | IXG-2C7(-*) | 192.168.1.16 | 00:0B:AA:3C:00:5E | 0.73 | |
| | | Entrance Station1 | IXG-DM7(-*) | 192.168.1.10 | 00:0B:AA:41:00:7D | 0.72 | |

2.2 Download Settings

Obtain (download) settings from a station.

Downloading can be performed only if "Association Settings" have been configured in advance in Administrator mode.

Select "Connection" - "Download Settings." The "Setting File Download" screen will be displayed.

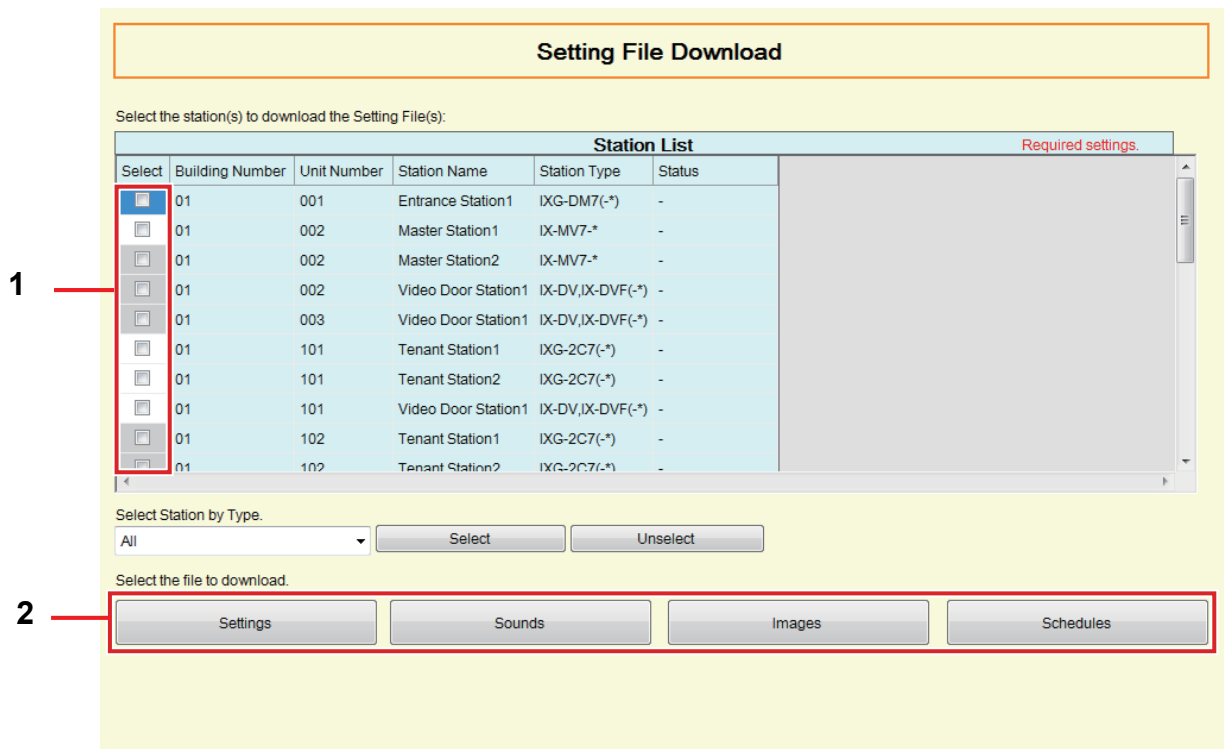

How to obtain settings

1. Select the station from which to download the setting file from "Station List." (Multiple selections allowed.)
 - To select or unselect stations in a batch, choose the station type and click **[Select]** or **[Unselect]**.
 - A station can be selected only if "Association Settings" have been configured for the station in Administrator mode.
2. Download the file.
 - [Settings]**: Download only the setting file.
 - [Sounds]**: Download the setting file and audio file for a custom tone.
 - [Images]** (IXG-DM7(-*) only): Download the setting file and the image file for Welcome Screen Settings.
 - [Schedules]** (IX-MV7-* only): Download transfer and other schedule setting files.

3. Click **[OK]**.

- Click **[Cancel]** to return to the "Setting File Download" screen without downloading.

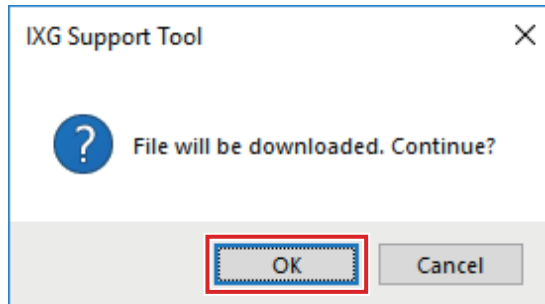
**4.** Click **[OK]**.

- The file download result is displayed in "Station List" - "Status."
 - In Process: The file is in the process of downloading.
 - Success: Download is completed.
 - Failed: Download failed. Try downloading again.
 - Unavailable: This is displayed when a file that cannot be uploaded to a station is selected to download in Step 2.
- Downloaded files are saved as follows in "Local Disk (C)" - "users" - "public" - "Documents" - "Aiphone" - "IXG" - "SupportTool" - "SystemData."
 - Setting file: "NewIXSystem(Set Site Name).db"
 - Sound file: Saved as a WAV file in "(Set Site Name)" - "Setting (Hidden Folder)" - "(Station Number)"
 - Image file: Saved as a PNG file in "(Set Site Name)" - "Setting (Hidden Folder)" - "(Station Number)"
 - Schedule file: Saved inside "(Set Site Name)" - "Setting (Hidden Folder)" - "(Station Number)" as "SCHED_CHIME.txt," "SCHED_GROUP.txt," "SCHED_OUTPUT.txt," "SCHED_TRANSFER.txt," or "SCHED_REC.txt" (the saved content differs depending on the station).

2.3 Upload Settings

Upload settings created using IXG Support Tool onto the station.

Uploading can be performed only if "Association Settings" have been configured in advance in Administrator mode. Select "Connection" - "Upload Settings." The "Setting File Upload" screen will be displayed.

! Important

- When the IXGW-GW settings have been uploaded, synchronize on the ["Manual IXG Cloud Server and Gateway Sync \(→page 71\)"](#) screen. The Intercom App cannot be used without synchronizing.
- If a custom tone/image was registered, be sure to upload each file to the station in "Sounds" - "Images." The following will occur if only the setting file is uploaded.
 - The default tone will play when the operation in which the custom tone was set is performed.
 - "Download Settings" will fail.
 - "Upload Settings" will fail.

Setting File Upload

Select the station(s) to upload the Setting File(s):

If you change the maximum simultaneous calls and upload the settings to the gateway adapter, the device will restart. It may take up to 10 minutes for the restart to complete.

| Select | Building Number | Unit Number | Station Name | Station Type | Status | Required settings. |
|-------------------------------------|-----------------|-------------|---------------------|------------------|--------|--------------------|
| <input checked="" type="checkbox"/> | 01 | 001 | Entrance Station1 | IXG-DM7(-*) | - | |
| <input type="checkbox"/> | 01 | 002 | Master Station1 | IX-MV7-* | - | |
| <input type="checkbox"/> | 01 | 002 | Master Station2 | IX-MV7-* | - | |
| <input type="checkbox"/> | 01 | 002 | Video Door Station1 | IX-DV,IX-DVF(-*) | - | |
| <input type="checkbox"/> | 01 | 003 | Video Door Station1 | IX-DV,IX-DVF(-*) | - | |
| <input type="checkbox"/> | 01 | 101 | Tenant Station1 | IXG-2C7(-*) | - | |
| <input type="checkbox"/> | 01 | 101 | Tenant Station2 | IXG-2C7(-*) | - | |
| <input type="checkbox"/> | 01 | 101 | Video Door Station1 | IX-DV,IX-DVF(-*) | - | |
| <input type="checkbox"/> | 01 | 102 | Tenant Station1 | IXG-2C7(-*) | - | |
| <input type="checkbox"/> | 01 | 102 | Tenant Station2 | IXG-2C7(-*) | - | |

Select Station by Type.

All

Select file type to be uploaded.

Settings
Sounds
Images
Schedules

How to upload settings

1. Select the station from which to upload the setting file from "Station List." (Multiple selections allowed.)
 - To select or unselect stations in a batch, choose the type and click **[Select]** or **[Unselect]**.
 - A station can be selected only if "Association Settings" have been configured for the station in Administrator mode.
2. Upload the file.
 - [Settings]**: Upload only the setting file.
 - [Sounds]**: Upload the setting file and audio file for a custom tone.
 - [Images]** (IXG-DM7(-*) only): Download the setting file and the image file for Welcome Screen Settings.
 - [Schedules]** (IX-MV7-* only): Select and upload transfer and other schedule setting files. Refer to ["How to upload schedules \(→page 58\)"](#).
3. If **[Settings]**, **[Sounds]**, or **[Images]** was clicked, click **[OK]**.
 - Click **[Cancel]** to return to the "Setting File Upload" screen without uploading.

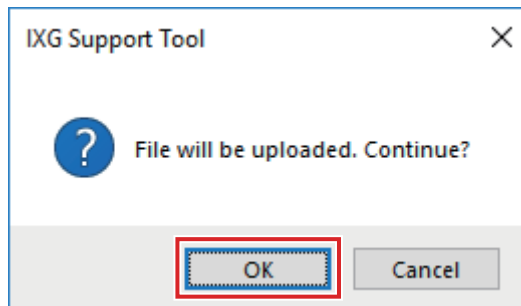

4. Click **[OK]**.
 - The file upload result is displayed in "Station List" - "Status."
 - In Process: The file is in the process of uploading.
 - Success: Upload is completed.
 - Failed: Upload failed. Try uploading again.
 - Unavailable: This is displayed when a file that cannot be uploaded was selected in Step 2.
5. When the IXGW-GW settings have been uploaded, click **[Sync]** on the ["Manual IXG Cloud Server and Gateway Sync \(→page 71\)"](#) screen.

How to upload schedules

In Step 2 of “[How to upload settings \(→page 57\)](#)”, if **[Schedules]** is clicked, the following screen is displayed.

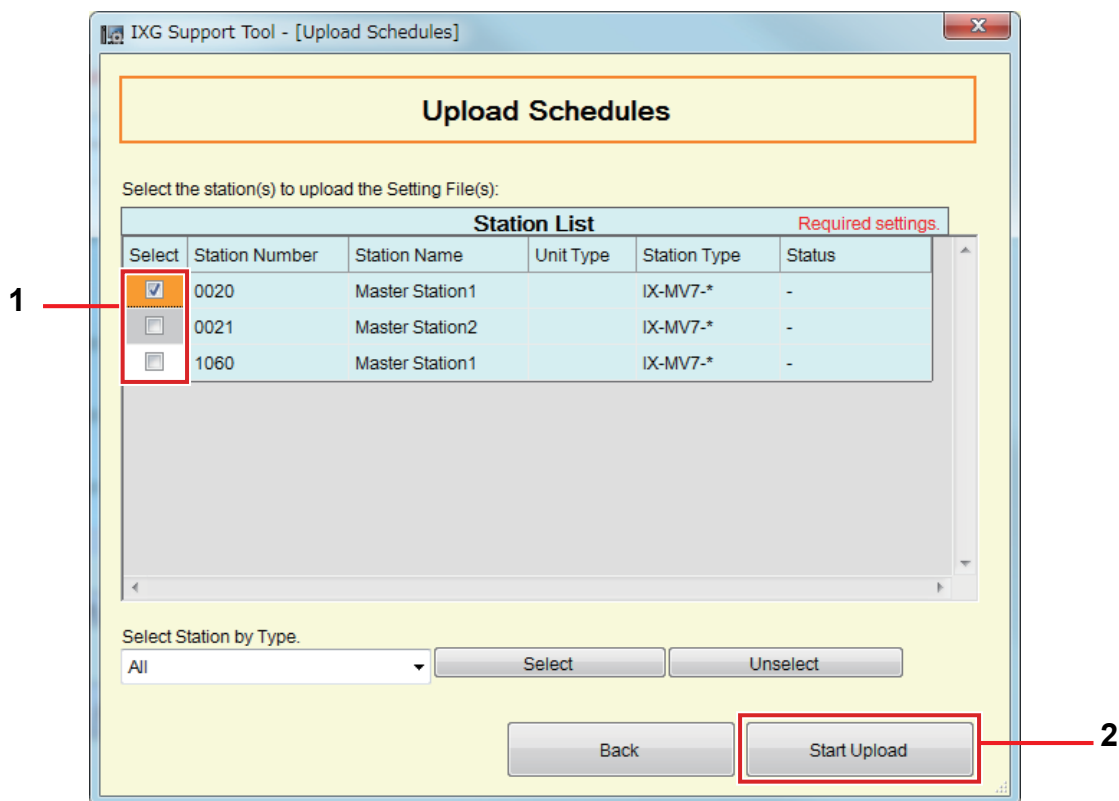

1. Select the station from which to upload the schedule file, from the station list. (Multiple selections allowed.)
 - To select or unselect stations in a batch, choose the station type and click **[Select]** or **[Unselect]**.
2. Click **[Start Upload]**.
3. Click **[OK]**.
 - Click **[Cancel]** to return to the "Upload Schedules" screen without uploading.

2.4 Download Log File

Obtain (download) log files from IXG-DM7(-*), IXG-2C7(-*), IXGW-LC, or IXGW-GW.

Downloading can be performed only if "Association Settings" have been configured in advance in Administrator mode.

Select "Connection" - "Download Log File ." The "Download Log" screen will be displayed.

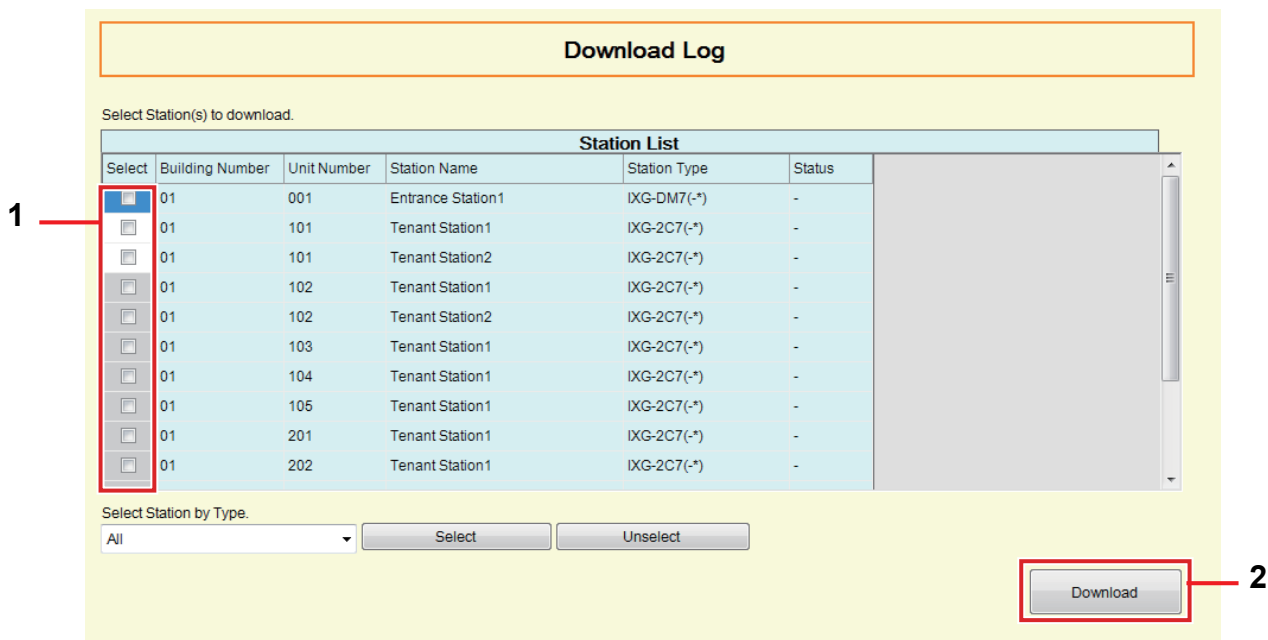

How to obtain log files

1. Select the station from which to download the log files from "Station List." (Multiple selections allowed.)
 - To select or unselect stations in a batch, choose the station type and click **[Select]** or **[Unselect]**.
 - A station can be selected only if "Association Settings" have been configured for the station in Administrator mode.
2. Click **[Download]**.
3. Click **[OK]**.
 - Click **[Cancel]** to return to the "Download Log" screen without downloading.
4. Select the folder where the log files are saved and click **[OK]**.
 - A folder with the name "Station Number_Date_log.gz" will be created in the specified directory, and the log files will be saved inside as hidden files.
 - Click **[Cancel]** to return to the "Download Log" screen without saving log files.
 - The file download result is displayed in "Station List" - "Status."
 - In Process: The file is in the process of downloading.
 - Success: Download is completed.
 - Failed: Download failed. Try downloading again.
5. Click **[OK]**.

3. App Integration

If the "App" was registered in ["Units / Stations \(→page 76\)"](#), registration on IXG Cloud Server is necessary. Create an IXG Cloud Server account and log in.

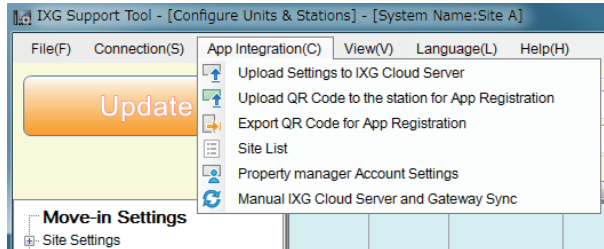

Configure the "IXG Cloud Server ID" and "Password" settings in Administrator mode. An email notification containing the details of the "IXG Cloud Server ID" and "Password" settings configured in Administrator mode is sent.

When logging in for the first time, enter the "ID" and "Password" that are provided in the email, and then follow the on-screen instructions to change the password.

3.1 Upload Settings to IXG Cloud Server

If "App" was registered in "[Units / Stations \(→page 76\)](#)", the following setting data configured in IXG Support Tool will need to be uploaded to IXG Cloud Server.

- Unit Name
- Station Name
- Station List
- Mobile App List

3.1.1 Uploading an existing site to the IXG Cloud Server

If the following settings were changed in IXG Support Tool, upload the changes to the IXG Cloud Server.

- Unit Name "[Units / Stations \(→page 76\)](#)"
- Station Name "[Identification \(→page 79\)](#)"
- Station List "[Station List \(→page 81\)](#)"
- Mobile App List "[Mobile App List \(→page 84\)](#)"

Select "App Integration" - "Upload Settings to IXG Cloud Server." The "IXG Cloud Server Login" screen will be displayed.



The screenshot shows a dialog box titled "IXG Support Tool - [IXG Cloud Server Login]". The dialog has a yellow background and a blue border. At the top, there is a title bar with a close button (X). The main content area contains the text "IXG Cloud Server Login" in bold. Below this, there are two input fields: "IXG Cloud Server ID" and "Password". Under the "Password" field, there is a blue hyperlink that says "*Forgot password?". At the bottom of the dialog, there are two buttons: "Login" and "Cancel".

How to apply settings to the IXG Cloud Server

1. Enter the "IXG Cloud Server ID" and "Password."
2. Click **[Login]**.
 - Login to the IXG Cloud Server.
 - Click **[Cancel]** to exit.
3. Click **[Upload]**.
 - Click **[Cancel]** to exit.

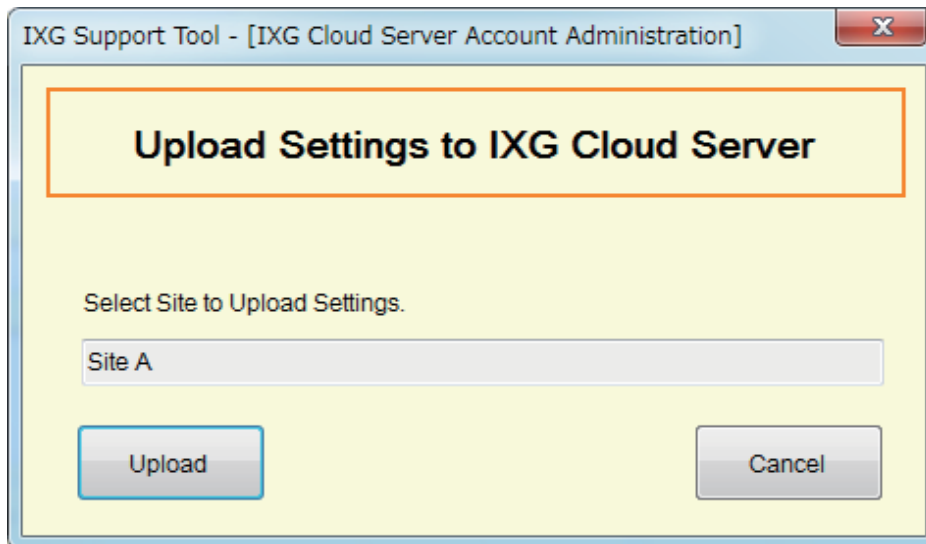

4. Click **[Agree]**.
- The changes are applied to IXG Cloud Server.
 - Click **[Disagree]** to exit.

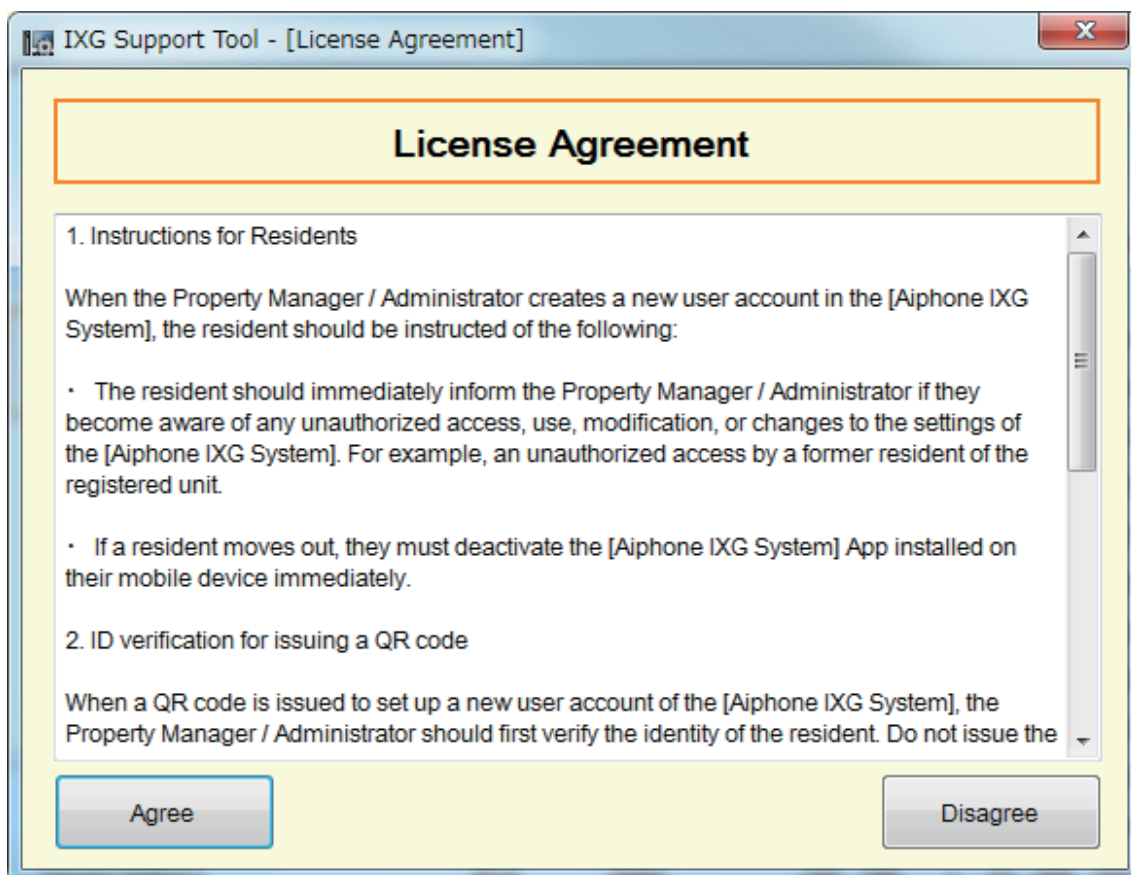

5. Click **[OK]** to send the QR Code for App Registration to the Tenant Station.
 - The QR code will be sent to the Tenant Station. Refer to [“Applying QR Code for App Registration to a station \(→page 64\)”](#) for details.
 - Click **[Cancel]** to exit.

3.2 Applying QR Code for App Registration to a station

After uploading the settings configured with IXG Support Tool in [“Upload Settings to IXG Cloud Server \(→page 61\)”](#), a QR Code for App Registration is sent to the Tenant Station. If there is no Tenant Station in a Residential unit or an Intercom App was registered in a non-Residential unit, refer to [“Export QR Code for App Registration \(→page 65\)”](#). The settings can be applied only if "Association Settings" have been configured in advance in Administrator mode. Click "App Integration" - "Upload QR Code to the station for App Registration." The following screen will be displayed.



The screenshot shows a web interface with a yellow header bar containing a button labeled "Upload to station(s)". Below the button is a table with the following columns: Select, Building Number, Unit Number, Unit Name, Station Number, Station Name, Status, Available App(s), and Status. The table contains 13 rows of data for various residential units.

| Select | Building Number | Unit Number | Unit Name | Station Number | Station Name | Status | Available App(s) | Status |
|-------------------------------------|-----------------|-------------|----------------|----------------|-----------------|----------------------|------------------|---------|
| <input checked="" type="checkbox"/> | 01 | 101 | Residential101 | 1010 | Tenant Station1 | Uploaded | 3 | Success |
| <input checked="" type="checkbox"/> | 01 | 101 | Residential101 | 1011 | Tenant Station2 | Uploaded | 3 | Success |
| <input type="checkbox"/> | 01 | 102 | Residential102 | 1020 | Tenant Station1 | Association Required | 3 | |
| <input type="checkbox"/> | 01 | 102 | Residential102 | 1021 | Tenant Station2 | Association Required | 3 | |
| <input type="checkbox"/> | 01 | 103 | Residential103 | 1030 | Tenant Station1 | Association Required | 0 | |
| <input type="checkbox"/> | 01 | 104 | Residential104 | 1040 | Tenant Station1 | Association Required | 0 | |
| <input type="checkbox"/> | 01 | 105 | Residential105 | 1050 | Tenant Station1 | Association Required | 0 | |
| <input type="checkbox"/> | 01 | 201 | Residential201 | 2010 | Tenant Station1 | Association Required | 0 | |
| <input type="checkbox"/> | 01 | 202 | Residential202 | 2020 | Tenant Station1 | Association Required | 0 | |
| <input type="checkbox"/> | 01 | 203 | Residential203 | 2030 | Tenant Station1 | Association Required | 0 | |
| <input type="checkbox"/> | 01 | 204 | Residential204 | 2040 | Tenant Station1 | Association Required | 0 | |
| <input type="checkbox"/> | 01 | 205 | Residential205 | 2050 | Tenant Station1 | Association Required | 0 | |

How to upload the QR code to the station

1. Select the Tenant Station to send the QR Code for App Registration.
2. Click **[Upload to station(s)]**.
 - The result will be displayed in "Status."
 - In Process: The QR code is being sent.
 - Success: The QR code has been applied.
 - Failed: The QR code has not been applied. Try again.
3. Click **[OK]**.

3.3 Export QR Code for App Registration

Once the settings files have been uploaded to the IXG Cloud Server in [“Upload Settings to IXG Cloud Server \(→page 61\)”](#) generate a PDF file with QR code. A QR code for App Registration can be sent to the Tenant Station if a Tenant Station is registered in the Residential Unit. Refer to [“Applying QR Code for App Registration to a station \(→page 64\)”](#).

The settings can be applied only if "Association Settings" have been configured in advance in Administrator mode. Click "App Integration" - "Export QR Code for App Registration." The following screen will be displayed.

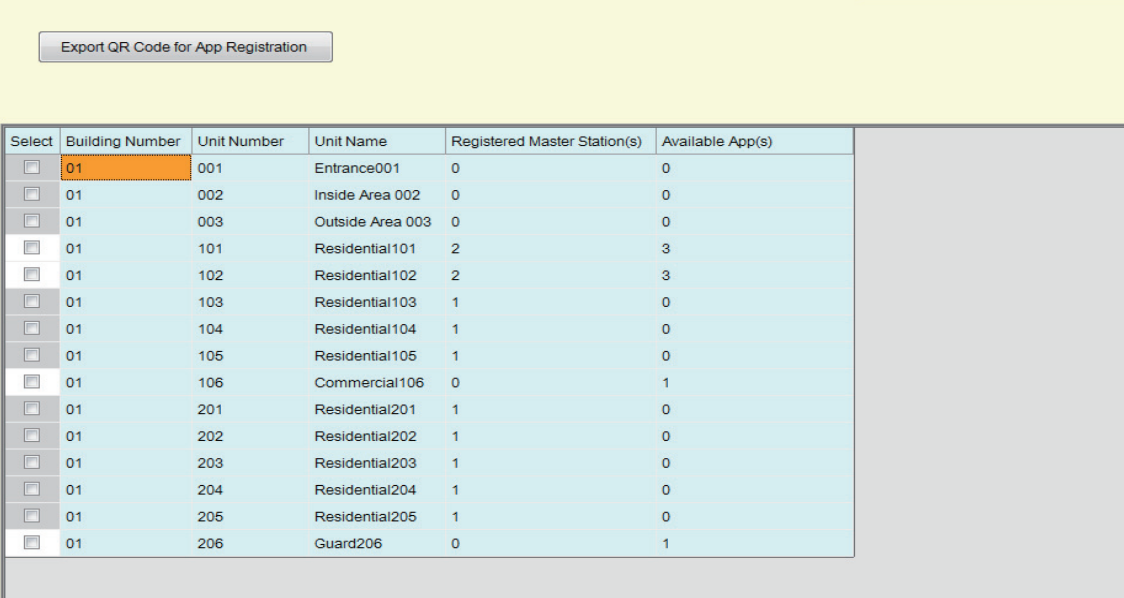

| Select | Building Number | Unit Number | Unit Name | Registered Master Station(s) | Available App(s) |
|-------------------------------------|-----------------|-------------|------------------|------------------------------|------------------|
| <input checked="" type="checkbox"/> | 01 | 001 | Entrance001 | 0 | 0 |
| <input type="checkbox"/> | 01 | 002 | Inside Area 002 | 0 | 0 |
| <input type="checkbox"/> | 01 | 003 | Outside Area 003 | 0 | 0 |
| <input type="checkbox"/> | 01 | 101 | Residential101 | 2 | 3 |
| <input type="checkbox"/> | 01 | 102 | Residential102 | 2 | 3 |
| <input type="checkbox"/> | 01 | 103 | Residential103 | 1 | 0 |
| <input type="checkbox"/> | 01 | 104 | Residential104 | 1 | 0 |
| <input type="checkbox"/> | 01 | 105 | Residential105 | 1 | 0 |
| <input type="checkbox"/> | 01 | 106 | Commercial106 | 0 | 1 |
| <input type="checkbox"/> | 01 | 201 | Residential201 | 1 | 0 |
| <input type="checkbox"/> | 01 | 202 | Residential202 | 1 | 0 |
| <input type="checkbox"/> | 01 | 203 | Residential203 | 1 | 0 |
| <input type="checkbox"/> | 01 | 204 | Residential204 | 1 | 0 |
| <input type="checkbox"/> | 01 | 205 | Residential205 | 1 | 0 |
| <input type="checkbox"/> | 01 | 206 | Guard206 | 0 | 1 |

How to export the QR Code for App Registration

1. Select the unit to register a Mobile App.
2. Click **[Export QR Code for App Registration]**.
3. Specify the save directory and click **[OK]**.
 - A file with the name "(Building Number)_(Unit Number)" will be saved in the specified directory.
4. Click **[OK]**.

3.4 Site List

Check the list of sites that are being managed.

Select "App Integration" - "Site List." The following screen will be displayed.

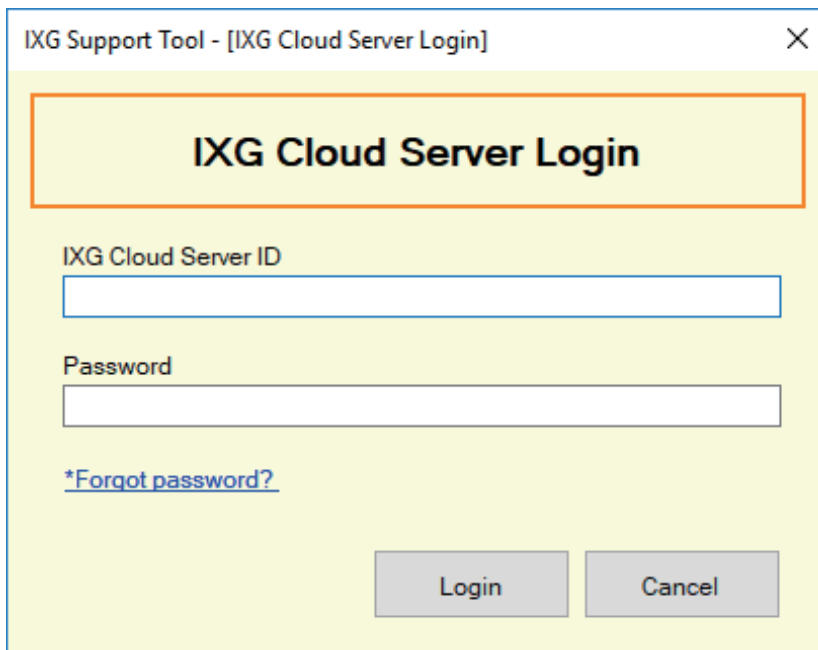

IXG Support Tool - [IXG Cloud Server Login]

IXG Cloud Server Login

IXG Cloud Server ID

Password

[*Forgot password?](#)

Login Cancel

How to configure Site List Settings

1. Enter the "IXG Cloud Server ID" and "Password."
2. Click **[Login]**.
 - Login to the IXG Cloud Server.
 - Click **[Cancel]** to exit IXG Cloud Server Login.
3. Check the site list.
 - Click **[Close]** to finish configuring the Site List / Property Manager Account Settings.

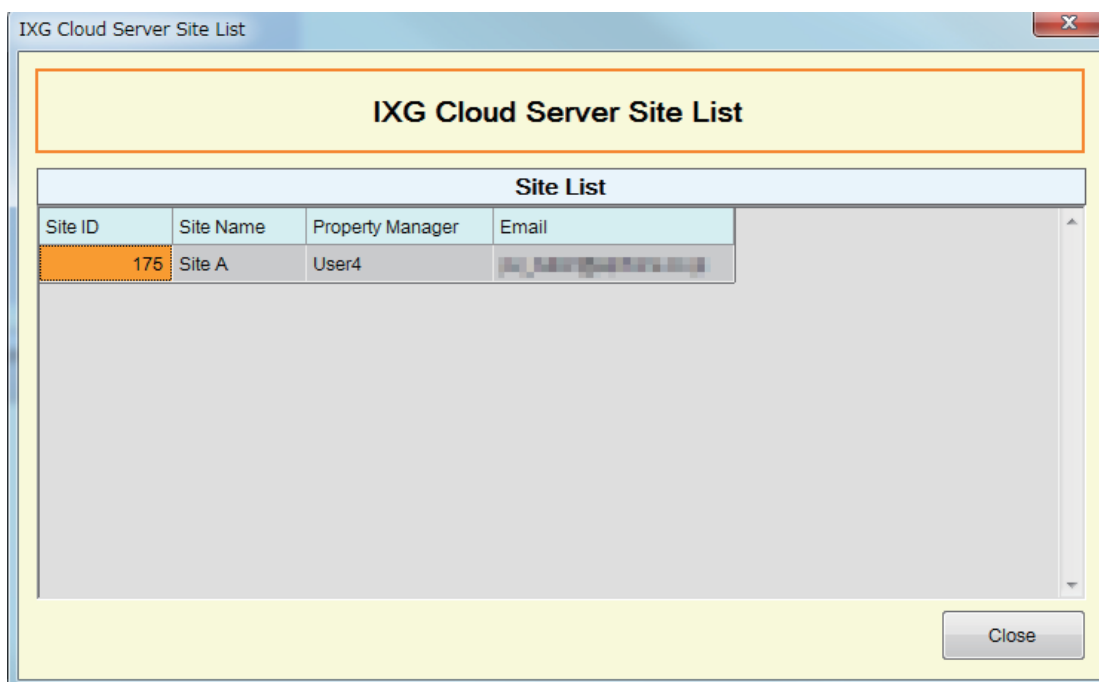

IXG Cloud Server Site List

IXG Cloud Server Site List

| Site List | | | |
|-----------|-----------|------------------|------------|
| Site ID | Site Name | Property Manager | Email |
| 175 | Site A | User4 | [redacted] |

Close

3.5 Property manager Account Settings

Change the email address and password that are registered for the property manager. Configure this if the registered email address was changed, or to change the password. Select "App Integration" - "Property Manager." The following screen will be displayed.

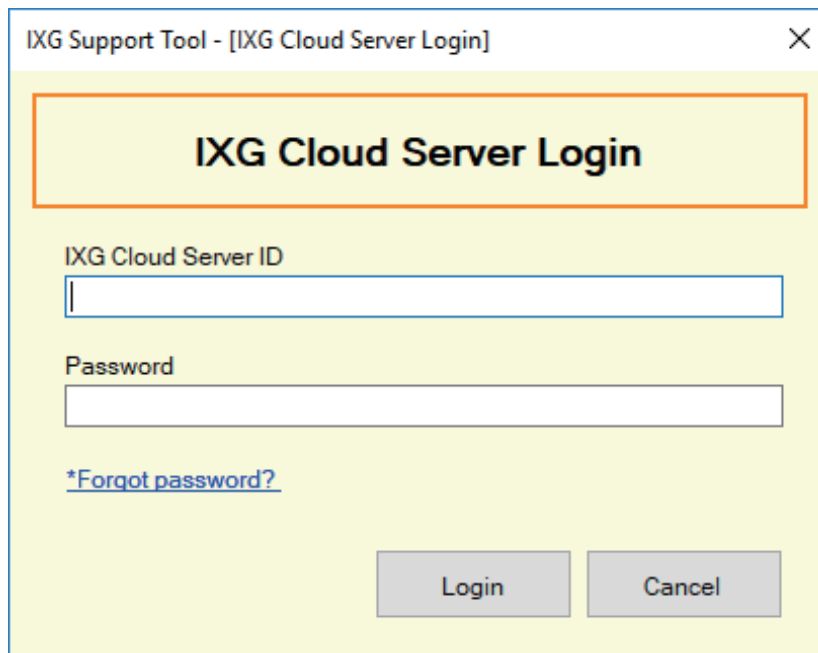

The screenshot shows a dialog box titled "IXG Support Tool - [IXG Cloud Server Login]". Inside the dialog, there is a yellow box with the title "IXG Cloud Server Login". Below this, there are two input fields: "IXG Cloud Server ID" and "Password". A link "*Forgot password?" is located below the password field. At the bottom of the dialog, there are two buttons: "Login" and "Cancel".

How to configure the property manager account settings

1. Enter the "IXG Cloud Server ID" and "Password."
2. Click **[Login]**.
 - Login to the IXG Cloud Server.
 - Click **[Cancel]** to exit.

3. Change the following information if required.
- Change Email Address: Enter the new email address and click **[Change Email Address]**. (Email: 1-64 alphanumeric characters.)
 - Change Password: Enter the current and new passwords, and then click **[Change Password]**. (The password must be at least 8 alphanumeric characters and include uppercase letters, lowercase letters, and numbers.)
 - Click **[Close]** to finish configuring the property manager account settings.

The screenshot shows a dialog box titled "IXG Support Tool - [IXG Cloud Server Account Administration]". The main heading is "IXG Cloud Server Account Administration". It is divided into two sections: "Change Email Address" and "Change Password".

Change Email Address section:

- Field: "New Email Address" with an empty text input box.
- Button: "Change Email Address" (disabled).
- Text: "Email Address Status Verified".
- Button: "Activate" (disabled).

Change Password section:

- Field: "Current Password" with an empty text input box.
- Field: "New Password" with an empty text input box.
- Text: "The password must be at least 8 characters and include uppercase letters, lowercase letters, and numbers."
- Field: "Confirm Password" with an empty text input box.
- Button: "Change Password" (disabled).

At the bottom right of the dialog is a "Close" button.

4. If **[Change Email Address]** was clicked in Step 3, an email containing the Verification Code will be sent to the registered email address. Click **[OK]**.
5. Enter the received "Verification Code" and then click **[Activate]**.
- Click **[Cancel]** to exit.

The screenshot shows a dialog box titled "IXG Support Tool - [Email Authentication]". The main heading is "Email Authentication".

Text: "Enter the verification code."

Field: "Verification Code" with an empty text input box.

Buttons: "Activate" and "Cancel" (disabled).

6. Click **[OK]**.

3.5.1 Password Recovery

If the password used to login to the IXG Cloud Server was forgotten, a new password can be created. Click "App Integration" - "Upload Settings to IXG Cloud Server," "Site List," or "Property manager Account Settings." The following screen will be displayed.

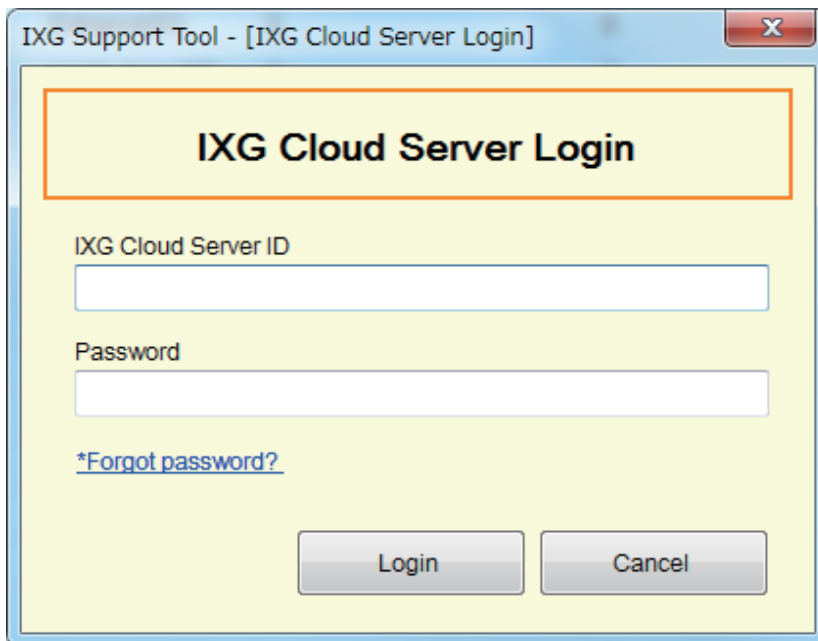

The screenshot shows a dialog box titled "IXG Support Tool - [IXG Cloud Server Login]". The main heading is "IXG Cloud Server Login". Below the heading are two input fields: "IXG Cloud Server ID" and "Password". A blue link labeled "*Forgot password?" is positioned below the password field. At the bottom of the dialog are two buttons: "Login" and "Cancel".

How to create a new password

1. Click [***Forgot password?**].
2. Enter "IXG Cloud Server ID" or "Email," and click [**Send Email**].
 - An email containing the Verification Code will be sent either to the email address associated with the IXG Cloud Server ID or to the email address that was entered.
 - Click [**Cancel**] to exit.

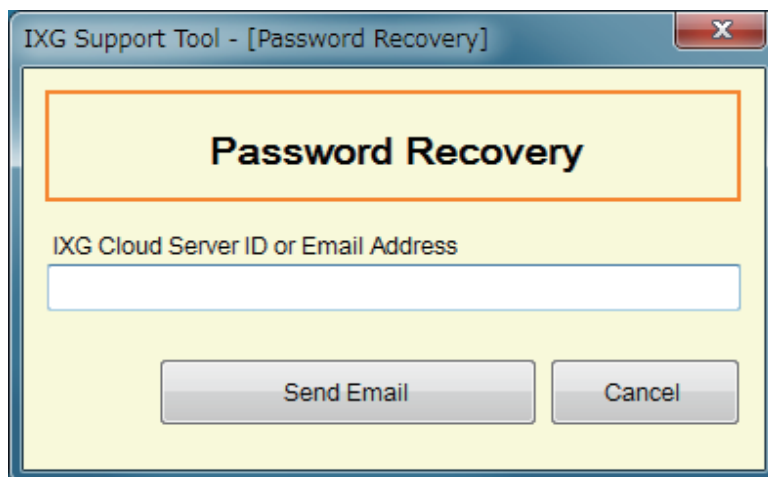

The screenshot shows a dialog box titled "IXG Support Tool - [Password Recovery]". The main heading is "Password Recovery". Below the heading is a single input field labeled "IXG Cloud Server ID or Email Address". At the bottom of the dialog are two buttons: "Send Email" and "Cancel".

Note

- Input the Email Address which is registered in the IXG Cloud Server for the Email Address.

3. Click **[OK]**.

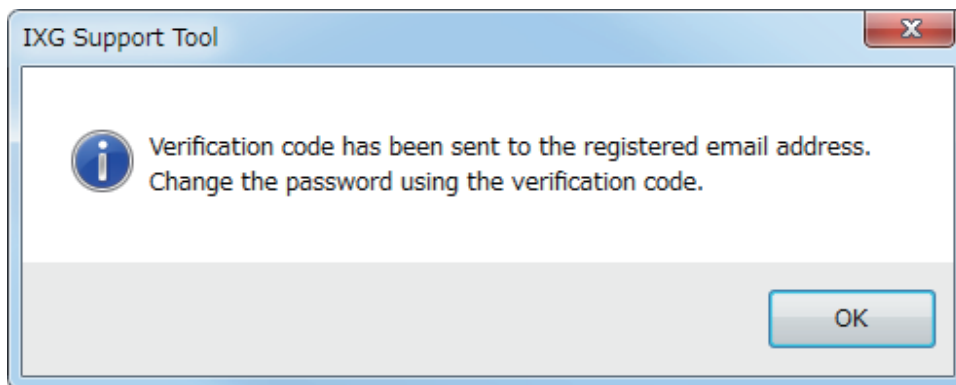

4. Enter the following information.

- Verification Code: Enter the "Verification Code" contained in the email.
- New Password: The password must be at least 8 alphanumeric characters and include uppercase letters, lowercase letters, and numbers.
- Confirm Password: Enter the same password again.



5. Click **[Change Password]**.
- The password will be changed.
 - Click **[Cancel]** to exit.

6. Click **[OK]**.

3.6 Manual IXG Cloud Server and Gateway Sync

If the app integration function is not working properly, synchronize the settings of the Gateway Adaptor and the IXG Cloud Server.

! Important

- The Gateway Adaptor can be configured only if "Association Settings" have been configured in Administrator mode, and the PC can communicate with the system.

Click "App Integration" - "Manual IXG Cloud Server and Gateway Sync" to display the following screen.

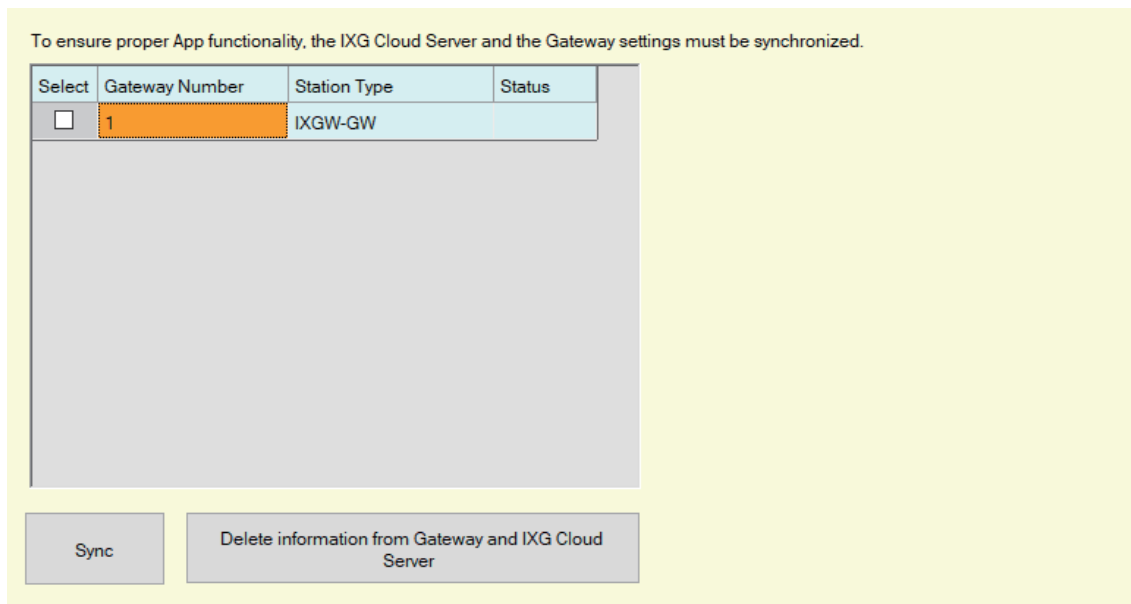

Manual IXG Cloud Server and Gateway Sync

1. Select the Gateway Adaptor to synchronize with the IXG Cloud Server.
2. Click **[Sync]**.
 - The IXG Cloud Server and the Gateway Adaptor will be synchronized.
 - The file synchronization result is displayed in "Status."
 - In Process: Currently synchronizing.
 - Success: Synchronization successful.
 - Failed: Synchronization failed. Try synchronizing again.

How to delete linked information from the Gateway and the IXG Cloud Server

If app integration will no longer be used, delete the gateway information from the IXG Cloud Server and the IXG Cloud Server information from the gateway.

1. Select the Gateway Adaptor for which to delete the link.
2. Click **[Delete information from Gateway and IXG Cloud Server]**.
 - The gateway information is deleted from the IXG Cloud Server, and the IXG Cloud Server information is deleted from the gateway.
 - The result is displayed in "Status."
 - In Process: Linked information is being deleted.
 - Success: Linked information has been deleted.
 - Failed: Linked information has not been deleted, try again.

4. View

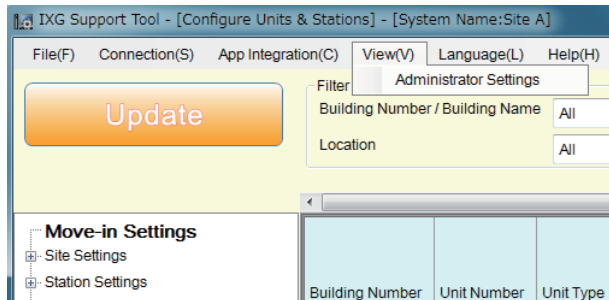

Switch to Administrator Settings (Administrator mode).

In Administrator mode, "Basic" and "Advanced" settings are available.

- Basic: Configure only the following settings.

- Site Information
- Building Information
- Units / Stations
- Gateway Registration
- Gateway Selection
- Identification
- ID / Password
- IP Address
- DNS
- NTP

- Advanced: Perform detailed configuration for all functions.

For information on Administrator mode, refer to the separate "IXX Support Tool Setting Manual: Administrator Mode."

5. Language

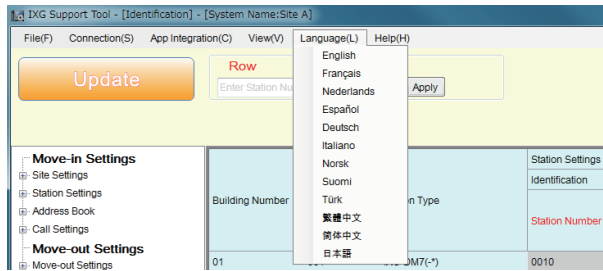

Set the language of following items.

- The display content of the IXC Support Tool.
- The language used to enter setting data (Units / Stations, etc.)
- The content of the email message.

! Important

- The language used on each station can be changed on the Settings screen of each station.
- If the language (configured on the station main unit) displayed on the screen for IXG-2C7(-*), IX-MV7-*, IXG-DM7(-*), or Intercom App is different from the language set with "Apply" the characters may appear incorrectly. To avoid this, enter information in the setting data using alphabetical characters only.

6. Help

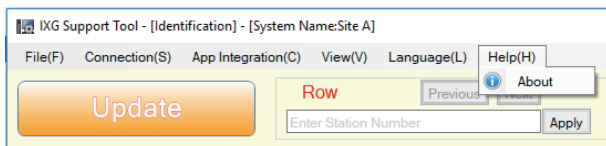

6.1 About

Select "Help" - "About." The "About" screen will be displayed.

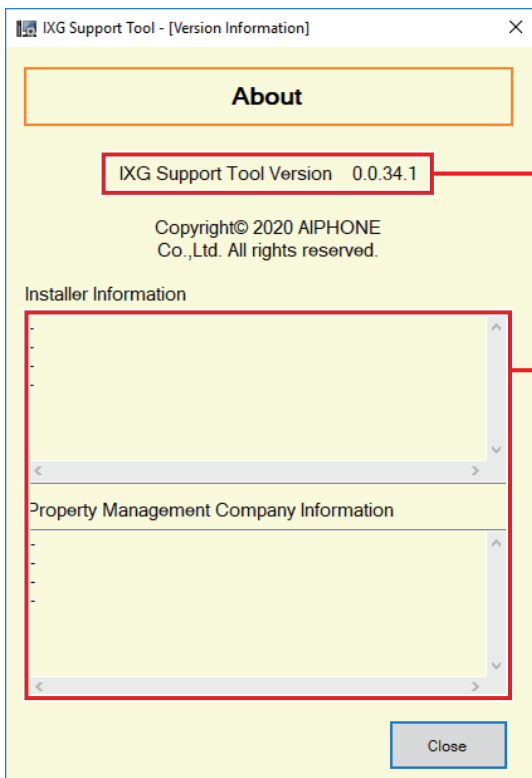

The current version of the IXG Support Tool.

The Installer Information and Property Management Information that was entered in "Administrator mode" is displayed.

Click **[Close]** to close the "About" screen.

System Settings

Important

- Depending on the display language of the Master Station (IXG-2C7(-*), IX-MV7-*, IXG-DM7(-*), or Intercom App), the settings may appear incorrectly.
- The symbols indicate the following:
 - ◆: Be sure to enter a setting value. Use the default values, unless a change is necessary.

1. Site Information (Move-in Settings)

1.1 Units / Stations

Configure common area and private area information.

Up to 9,999 units can be registered.

Up to 9,999 IXG and IX stations can be registered. Up to 9,999 Mobile Apps can be registered.

Register IXG and IX stations in Administrator mode.

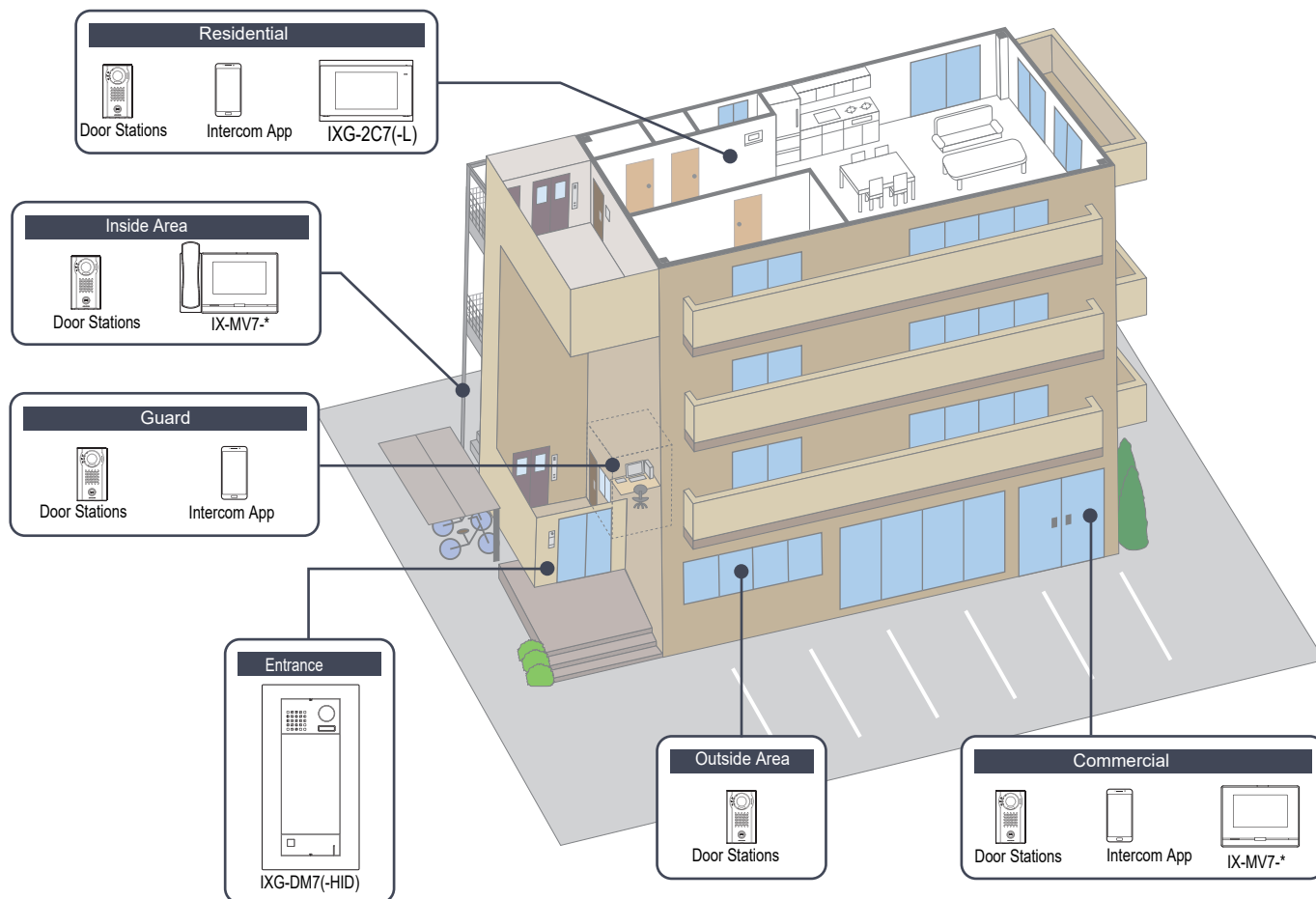

Configure unit information.

Up to 9,999 IXG and IX stations can be registered. Up to 9,999 Mobile Apps can be registered.

Filter

Building Number / Building Name: Select a building to display, and then click **[Apply]** to display only the items for the selected building.

Unit Type: Select a unit type to display, and then click **[Apply]** to display only the items for the selected unit type.

Display Settings

Check the Display Settings box, select the number to display for each station, and then click **[Apply]**.

The screenshot shows the system settings interface. At the top, there are two main sections: 'Filter' and 'Display Settings'. The 'Filter' section includes dropdown menus for 'Building Number / Building Name' (set to 'All') and 'Unit Type' (set to 'All'). The 'Display Settings' section includes checkboxes for 'First Name / Last Name', 'Number of Master Stations' (set to 2), 'Number of Mobile Apps' (set to 3), and 'Number of Door / Entrance Stations' (set to 1). An 'Apply' button is located to the right of these settings.

Below the settings is a table titled 'Site Information' with a 'Required settings' link. The table has columns for 'Building Number', 'Unit Number', 'Unit Type', 'Unit Name', 'First Name', 'Last Name', 'Master / Tenant Station 1', 'Master / Tenant Station 2', 'Door / Entrance Station 1', and 'App 1'. The table contains 26 rows of data, with the first row (Unit 001) highlighted in orange. Each row has a 'Select' button in the 'Unit Name' column and another 'Select' button in the 'App 1' column.

! Important

- “[Language \(→page 73\)](#)” must be set before continuing.
- Enter using the language set in “[Language \(→page 73\)](#)”. However, if the language (configured on the station main unit) displayed on the screen for IXG-2C7(-*), IX-MV7-*, IXG-DM7(-*), or Intercom App is different from the language set with “[Language \(→page 73\)](#)”, the characters displayed on the station screen may appear incorrectly. To avoid this, enter information using alphabetical characters only.

■ Unit Name ◆

| | |
|-------------|---|
| Description | Configure the name of the unit. The Unit Name will be displayed when placing a call. The Unit Name will be displayed on the selection button of the Search by List Screen for the Entrance Station. (Guard, Inside Area, Commercial only) |
| Settings | 1-24 alphanumeric characters |

■ First Name (Residential only)

| | |
|-------------|---|
| Description | Enter the first name. The First Name will be displayed on the selection button of the Search by List Screen on the Entrance Station. This is also used to search for a destination on the Entrance Station. |
| Settings | 1-16 alphanumeric characters |

■ Last Name (Residential only)

| | |
|-------------|---|
| Description | Enter the last name. The Last Name will be displayed on the selection button of the Search by List Screen on the Entrance Station. This is also used to search for a destination on the Entrance Station. |
| Settings | 1-16 alphanumeric characters |

Note

- Only alphanumeric characters can be entered on the Search by Name Screen for an Entrance Station, so enter only alphanumeric characters for the "First Name" and "Last Name" when using "Search by Name" with an Entrance Station.

■ App (Guard, Commercial, Residential only)

| | |
|-------------|---|
| Description | Configure the station type of the app to register to Guard, Commercial, or Residential Unit. Up to 8 Mobile Apps can be registered in each unit. Click [Select] and select the app station type. |
| Settings | Intercom App, Delete |

2. Station Information (Move-in Settings)

2.1 Identification

Configure the Station Number and Station Name of the station to register in the system.

Move row

Up to 50 station number rows can be displayed at a time. Switch the screen as follows.

[Previous]: Display the previous 50 rows.

[Next]: Display the next 50 rows.

[Apply]: Enter the station number and click **[Apply]** to move the cursor to the row of the station number that was entered.

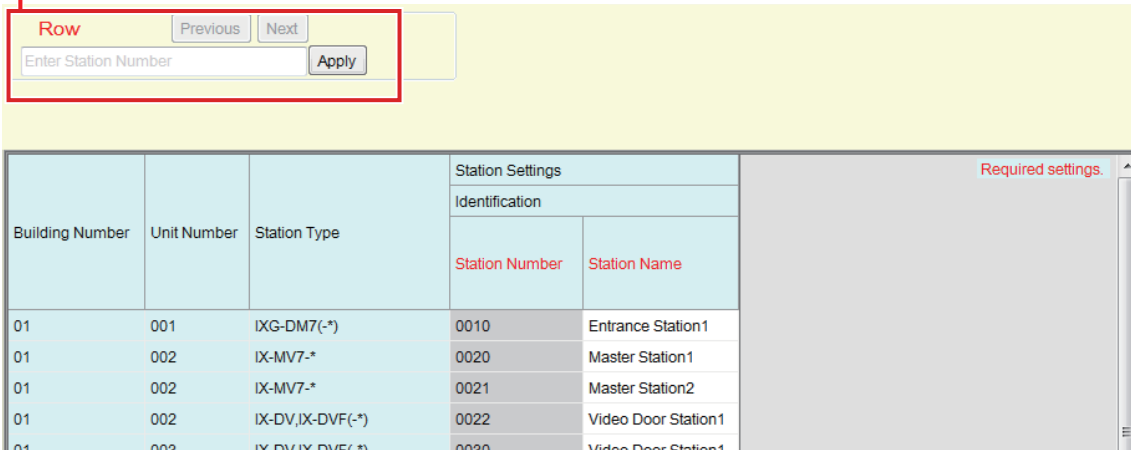

! Important

- Always set "[Language \(→page 73\)](#)" before setting "Identification."
- Enter using the language set in "[Language \(→page 73\)](#)". However, if the language (configured on the station main unit) displayed on the screen for IXG-2C7(-*), IX-MV7-*, IXG-DM7(-*), or Intercom App is different from the language set with "[Language \(→page 73\)](#)", the characters displayed on the station screen may appear incorrectly. To avoid this, enter information using alphabetical characters only.

■ Station Number◆

| | |
|-----------------|---|
| Compatible type | <input type="checkbox"/> IXG-2C7(-*) <input type="checkbox"/> IXG-MK <input type="checkbox"/> IX-MV7-* <input type="checkbox"/> IXG-DM7(-*) <input type="checkbox"/> IX-DA <input type="checkbox"/> IX-BA <input type="checkbox"/> IX-DV, IX-DVF(-*) <input type="checkbox"/> IX-SSA(-*) <input type="checkbox"/> IX-EA, IX-EAU <input type="checkbox"/> IX-FA <input type="checkbox"/> IXGW-LC <input type="checkbox"/> IXGW-GW <input checked="" type="checkbox"/> Intercom App |
| Description | Set the station number. Ensure that it does not overlap with the unit number or another station number. The set station number will be shown on the destination station when placing a call or when paging is performed. |
| Settings | 3-24 digits |
| Default value | Single Building System: Unit Number+sequence number starting from 000 for each unit type Multiple Building System: Building Number+Unit Number+sequence number starting from 000 for each unit type |

■ Station Name ◆

| | |
|-----------------|---|
| Compatible type | <input checked="" type="checkbox"/> IXG-2C7(-*) <input type="checkbox"/> IXG-MK <input checked="" type="checkbox"/> IX-MV7-* <input checked="" type="checkbox"/> IXG-DM7(-*) <input checked="" type="checkbox"/> IX-DA <input checked="" type="checkbox"/> IX-BA <input checked="" type="checkbox"/> IX-DV, IX-DVF(-*) <input checked="" type="checkbox"/> IX-SSA(-*) <input checked="" type="checkbox"/> IX-EA, IX-EAU <input checked="" type="checkbox"/> IX-FA <input checked="" type="checkbox"/> IXGW-LC <input checked="" type="checkbox"/> IXGW-GW <input checked="" type="checkbox"/> Intercom App |
| Description | Set the station name. The set station name will be shown on the destination station when placing a call. |
| Settings | 1-24 alphanumeric characters |
| Default value | <ul style="list-style-type: none"> • Intercom App: Intercom App (number) • Stations other than Intercom App: - |

3. System Information (Move-in Settings)

3.1 Station List

| | |
|-----------------|---|
| Compatible type | <input checked="" type="checkbox"/> IXG-2C7(-*) <input type="checkbox"/> IXG-MK <input checked="" type="checkbox"/> IX-MV7-* <input checked="" type="checkbox"/> IXG-DM7(-*) <input type="checkbox"/> IX-DA <input type="checkbox"/> IX-BA <input type="checkbox"/> IX-DV, IX-DVF(-*) <input type="checkbox"/> IX-SSA(-*) <input type="checkbox"/> IX-EA, IX-EAU <input type="checkbox"/> IX-FA <input type="checkbox"/> IXGW-LC <input type="checkbox"/> IXGW-GW <input checked="" type="checkbox"/> Intercom App |
|-----------------|---|

Configure the address book for IX-MV7-*, IXG-2C7(-*), IXG-DM7(-*), or Intercom App.

Up to 500 stations can be registered only on the IXG-2C7(-*).

The number of stations which can be registered on the IX-MV7-* is the number of stations registered on the [“Station List \(→page 81\)”](#) plus the number of units registered on the [“Mobile App List \(→page 84\)”](#) for a maximum total of 9,998.

Calling, paging, monitoring (IXG-DM7(-*) and Door Stations only), line supervision, and device checking (IX Station only) can be performed by IX-MV7-* for stations registered in the Address Book.

Calling (except for IXG-DM7(-*), Door Stations) and monitoring (IXG-DM7(-*) and Door Stations only) can be performed by IXG-2C7(-*) for stations registered in the Address Book.

Calling can be performed by IXG-DM7(-*) for stations registered in the Address Book.

Monitoring can be performed by Intercom App for stations registered in the Address Book.

Monitoring can be performed for network cameras.

Move row

Up to 50 station number rows can be displayed at a time. Switch the screen as follows.

[Previous]: Display the previous 50 rows.

[Next]: Display the next 50 rows.

[Apply]: Enter the station number and click **[Apply]** to move the cursor to the row of the station number that was entered.

Move column

Up to 50 station number columns can be displayed at a time. Switch the screen as follows.

[Previous]: Display the previous 50 columns.

[Next]: Display the next 50 columns.

[Apply]: Enter the station number and click **[Apply]** to move the cursor to the column of the station number that was entered.

The screenshot shows two navigation panels at the top: 'Row' and 'Column'. Each panel has 'Previous', 'Next', and 'Apply' buttons, and a text input field for 'Enter Station Number'. Below these is a table with the following structure:

| Building Number | Unit Number | Station Name | System Information | | | |
|-----------------|-------------|-------------------|---------------------------------|----------------|----------------------------|-------------|
| | | | 0010 | 0020 | 0021 | Required se |
| | | | Entrance Station1 / IXG-DM7(-*) | | Master Station1 / IX-MV7-* | |
| | | | Select | Network Camera | Door Release Button | Select |
| 01 | 001 | Entrance Station1 | | | | |
| 01 | 002 | Master Station1 | ✓ | Network Camera | | ✓ |
| 01 | 002 | Master Station2 | ✓ | Network Camera | | ✓ |
| 01 | 101 | Tenant Station1 | ✓ | Network Camera | | |
| 01 | 101 | Intercom App1 | ✓ | | Disable | |
| 01 | 101 | Intercom App2 | ✓ | | Disable | |
| 01 | 101 | Intercom App3 | ✓ | | Disable | |
| 01 | 101 | Tenant Station2 | ✓ | Network Camera | | |

List of IX-MV7-*, IXG-2C7(-*), IXG-DM7(-*), and Intercom App in setting data

If a network camera has not been registered in "[Network Camera List \(->page 86\)](#)", this will not be shown.

List of stations that can be registered to the Address Book

! Important

- A station cannot be registered to the Address Book unless "IP Address" has been configured for the station in Administrator mode.

How to create a Station List

1. Search for the stations for which the Address Book will be set up from the "list of IX-MV7-*, IXG-2C7(-*), IXG-DM7(-*), and Intercom App in setting data."
2. Search for the station to be registered in the Address Book using "list of stations that can be registered to the Address Book."
3. Click the cells ("Select," "Network Camera," and "Door Release Button") that correspond to Steps 1 and 2.
 - Select: The station for which "✓" was selected will be registered in the Address Book.

- Network Camera (IX-MV7-* and IXG-2C7(-*)) only): Click **[Network Camera Selection]** to select the network camera to associate. Network cameras configured in [“Network Camera List \(→page 86\)”](#) may be selected. The number of the selected network camera is displayed. If a network camera is associated with a station, the video from the network camera will be displayed when placing a call, during a communication, or when monitoring.

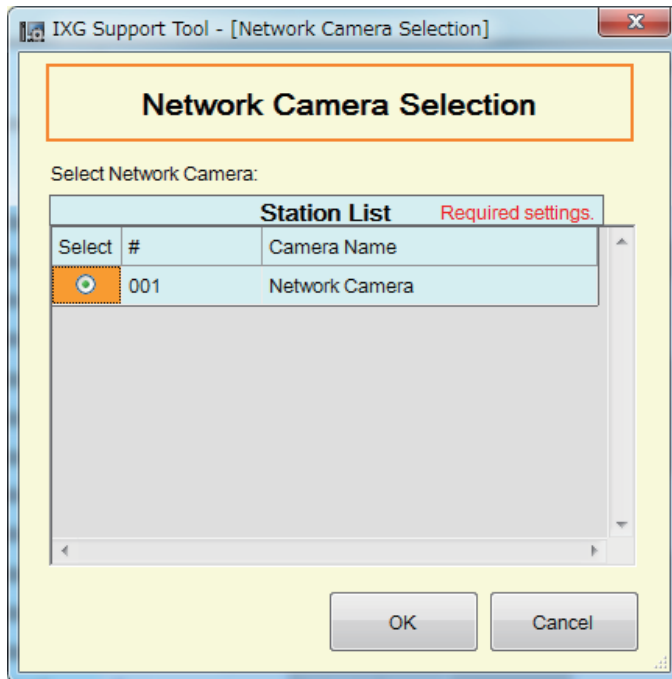

- Door Release Button (Intercom App only): Set whether to display the Door Release button on the station screen in order to release the door.
 - Disable: Do not display the Door Release button on the station screen.
 - Display 1 Only: Display only Door Release button 1 on the station screen.
 - Display 1 and 2: Display Door Release button 1 and Door Release button 2 on the station screen.

4. After configuration is complete, click **[Update]**.

5. Click **[OK]**.

3.2 Mobile App List

| | |
|-----------------|--|
| Compatible type | <input checked="" type="checkbox"/> IXG-2C7(-*) <input type="checkbox"/> IXG-MK <input checked="" type="checkbox"/> IX-MV7-* <input checked="" type="checkbox"/> IXG-DM7(-*) <input type="checkbox"/> IX-DA <input type="checkbox"/> IX-BA <input type="checkbox"/> IX-DV, IX-DVF(-*) <input type="checkbox"/> IX-SSA(-*) <input type="checkbox"/> IX-EA, IX-EAU <input type="checkbox"/> IX-FA <input type="checkbox"/> IXGW-LC <input type="checkbox"/> IXGW-GW <input type="checkbox"/> Intercom App |
|-----------------|--|

Register the unit containing the Mobile App to call in the Address Book.
 All Mobile Apps in a registered unit can be called at once.

The number of stations which can be registered on the IX-MV7-* is the number of stations registered on the [“Station List \(→page 81\)”](#) plus the number of units registered on the [“Mobile App List \(→page 84\)”](#) for a maximum total of 9,998.

Move row

Up to 50 station number rows can be displayed at a time. Switch the screen as follows.
[Previous]: Display the previous 50 rows.
[Next]: Display the next 50 rows.
[Apply]: Enter the station number and click **[Apply]** to move the cursor to the row of the station number that was entered.

Move column

Up to 50 station number columns can be displayed at a time. Switch the screen as follows.
[Previous]: Display the previous 50 columns.
[Next]: Display the next 50 columns.
[Building Number]: Select the building.
[Apply]: Select the building number and enter the unit number and click **[Apply]** to move the cursor to the column of the unit number that was entered.

List of IX-MV7-*, IXG-2C7(-*) and IXG-DM7(-*) in setting data

List of units that can be registered to the Address Book

Mobile App List

1. Search for the stations for which the Address Book will be set up from the "list of IX-MV7-*, IXG-2C7(-*) and IXG-DM7(-*) in setting data."
2. Search for the unit to be registered in the Address Book using "list of units that can be registered to the Address Book."
3. Click the cell that corresponds to Steps 1 and 2.
 - Select: The unit for which "✓" was selected will be registered in the Address Book.
4. After configuration is complete, click **[Update]**.

5. Click **[OK]**.

3.3 Network Camera List

IX-MV7-* and IXG-2C7(-*) support ONVIF Profile S and RTSP.

Video and audio captured by a 3rd party network camera and microphone can be monitored on the IX-MV7-* or IXG-2C7(-*) screen.

Register the network camera in the Address Book. Up to 500 network cameras can be registered.

Configure "Network Camera Integration" to configure event notification-related settings for the network camera in Administrator mode.

| Resolution of network cameras capable of displaying video | Resolution of network cameras capable of recording video |
|---|--|
| <ul style="list-style-type: none"> IX-MV7-*: SXGA IXG-2C7(-*): WVGA | <ul style="list-style-type: none"> IX-MV7-*: SXVGA IXG-2C7(-*): WVGA |

Move row
Up to 50 station number rows can be displayed at a time. Switch the screen as follows.
[Previous]: Display the previous 50 rows.
[Next]: Display the next 50 rows.
[Apply]: Enter the station number and click **[Apply]** to move the cursor to the row of the station number that was entered.

Move column
Up to 50 station number columns can be displayed at a time. Switch the screen as follows.
[Previous]: Display the previous 50 columns.
[Next]: Display the next 50 columns.
[Apply]: Enter the station number and click **[Apply]** to move the cursor to the column of the station number that was entered.

List of network cameras that can be registered to the Address Book

["Network Camera Registry \(→page 87\)"](#)

List of IX-MV7-* and IXG-2C7(-*) in setting data

If no network camera is registered, this will not be shown.

How to create a Network Camera List

1. Register the network camera in ["Network Camera Registry \(→page 87\)"](#).
2. Search for the stations for which the Address Book will be set up from the "list of IX-MV7-* and IXG-2C7(-*) in setting data."

3. Identify the network camera to be registered in the Address Book using "List of network cameras that can be registered to the Address Book."
4. Click the cells ("Select" and "Audio Monitoring") that correspond to Steps 2 and 3.
 - Select: Register network cameras with "✓" selected to the Address Book.
 - Audio Monitoring: Configure whether to allow monitoring of network camera audio from the station.

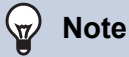
**Note**

- For IXG-2C7(-*), "Audio Monitoring" is set to "Enable" and cannot be changed.

5. After configuration is complete, click **[Update]**.
6. Click **[OK]**.

3.3.1 Network Camera Registry

Click **[Open Network Camera Registry]**. The following screen is displayed.

["How to register a new network camera \(→page 89\)"](#)

Select the network camera(s) to be deleted (multiple selections allowed), and click to delete.

| Station Settings | | Network Settings | | | Function Settings | | Required settings |
|-------------------------------------|-----|------------------|----------|-------------------|-------------------|------|-------------------|
| Select | # | Camera Name | Hostname | IP Address (IPv4) | IP Address (IPv6) | ID | Password |
| <input checked="" type="checkbox"/> | 001 | XXXXXXXXXX | | 192.168.1.200 | | XXXX | ***** |

If no network camera is registered, this will not be shown.

! Important

- Network camera registration can be performed only if "Association Settings" have been configured in Administrator mode on at least one IX-MV7-* or IXG-2C7(-*), and the PC can communicate with the system. (This is because, when registering a network camera, the network camera is searched through IX-MV7-* or IXG-2C7(-*).)
- Even if the network camera unit settings (resolution, etc.) are changed after uploading the settings to stations (IXG-2C7(-*), IX-MV7-*) which display network camera video with the IXG Support Tool, the settings are not updated on the stations. Because the network camera information on the station must be erased one time, follow the steps below.
 1. Delete the reconfigured network camera in the "Network Camera List."
 2. With the target network camera in an unregistered state, upload the settings to the station. (The network camera information will disappear on the station side)
 3. Register the target network camera from the "Network Camera List" once more and upload the settings to the station.

■ Camera Name ◆

| | |
|---------------|------------------------------|
| Description | Set the Network Camera Name. |
| Settings | 1-24 alphanumeric characters |
| Default value | - |

■ Hostname

| | |
|---------------|---|
| Description | Set the hostname. When setting the hostname, configure the "DNS" settings in Administrator mode. |
| Settings | 1-64 alphanumeric characters |
| Default value | - |

■ IP Address (IPv4)◆

| | |
|---------------|--|
| Description | Set the IPv4 address for Network camera. |
| Settings | 1.0.0.1-223.255.255.254 |
| Default value | - |

■ IP Address (IPv6)◆

| | |
|---------------|--|
| Description | Set the IPv6 address for Network camera. |
| Settings | ::FF:0-FE:FF:FFFF:FFFF:FFFF:FFFF:FFFF:FFFF |
| Default value | - |

■ ID◆

| | |
|---------------|---------------------------------|
| Description | Enter ID of the network camera. |
| Settings | 1-32 alphanumeric characters |
| Default value | - |

■ Password◆

| | |
|---------------|---------------------------------------|
| Description | Enter Password of the network camera. |
| Settings | 1-32 alphanumeric characters |
| Default value | - |



Note

- "Password" is displayed as "*****" in the Settings screen.

How to register a new network camera

Registration cannot be performed if the PC is not connected to the same network as the network camera.

Click **[Add Camera]** to search for a network camera. (Searching may take several minutes.)

When searching is complete, the "Network Camera Selection" screen is displayed, and the network cameras connected to the network are displayed in the "Network Camera Search List."

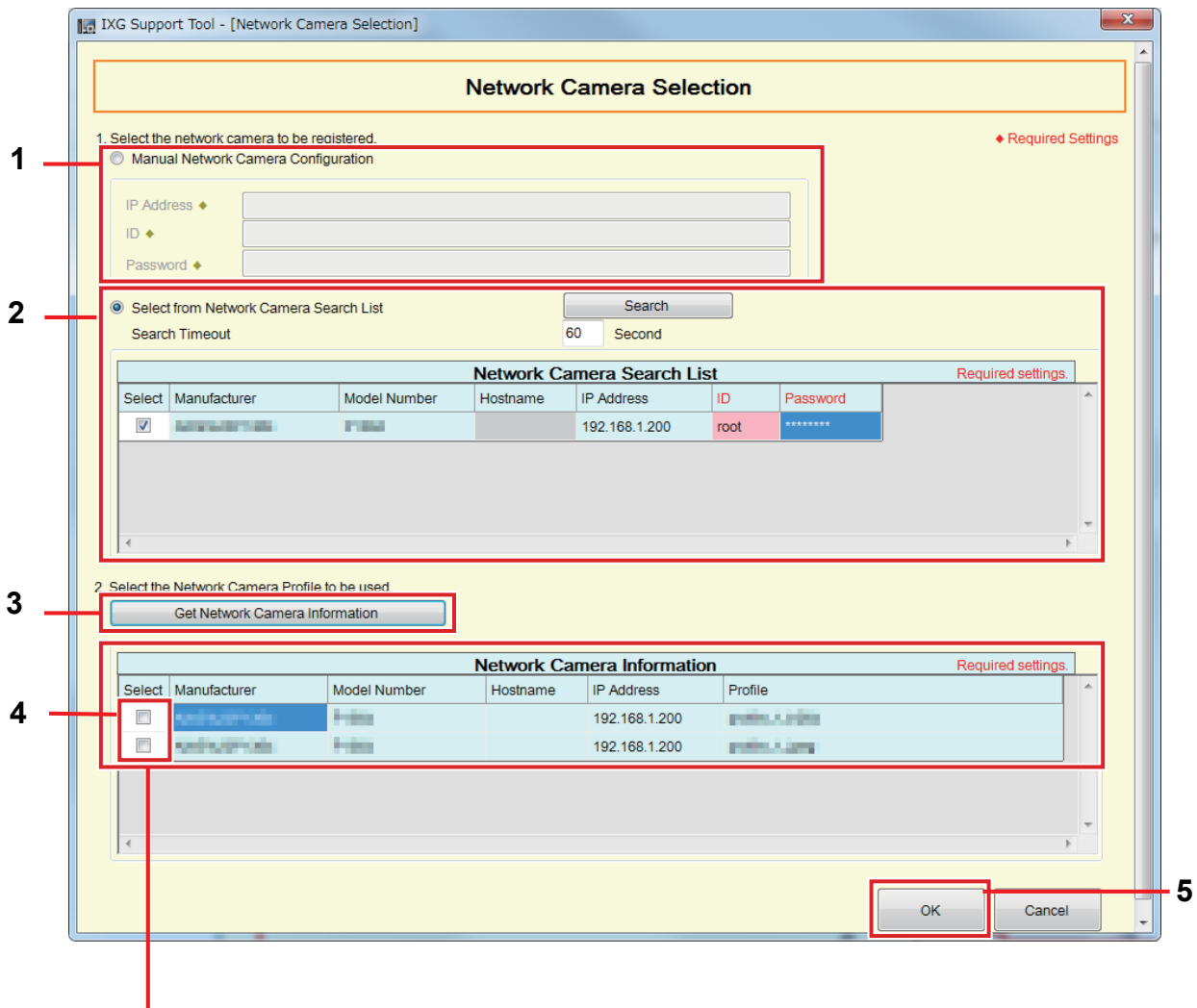

If the video profile cannot be obtained, nothing will be shown.

1. To register by specifying an IP address, select "Manual Network Camera Configuration," and then enter the "IP Address (Hostname)◆," "ID◆," and "Password◆" for the network camera.
2. To select from the Network Camera Search List, select "Select from Network Camera Search List." Select the network camera to register from the "Network Camera Search List" (multiple selections allowed), and then enter the "Hostname," "ID◆," and "Password◆." When entering the hostname, configure the "DNS" settings in Administrator mode. To search again, click **[Search]**. It is also possible change the search time.
3. Click **[Get Network Camera Information]**.
(Obtaining the video profile may take several minutes.)
When video profiles are successfully obtained, they will be shown in "Network Camera Information."
4. Choose the video profile to be registered from the list. (Multiple selections allowed.)
5. Click **[OK]** to register the network camera.

3.4 Group

| | |
|-----------------|---|
| Compatible type | <input type="checkbox"/> IXG-2C7(-*) <input type="checkbox"/> IXG-MK <input checked="" type="checkbox"/> IX-MV7-* <input type="checkbox"/> IXG-DM7(-*) <input type="checkbox"/> IX-DA <input type="checkbox"/> IX-BA <input type="checkbox"/> IX-DV, IX-DVF(-*) <input type="checkbox"/> IX-SSA(-*) <input type="checkbox"/> IX-EA, IX-EAU <input type="checkbox"/> IX-FA <input type="checkbox"/> IXGW-LC <input type="checkbox"/> IXGW-GW <input type="checkbox"/> Intercom App |
|-----------------|---|

Configure the group for groups calls, group pages, and contact input calls.

Up to 50 stations can be added per group (when registering a Mobile App, 49 stations per group and a single unit containing the Mobile App), and up to 99 groups can be configured.

Move row

Up to 50 station number rows can be displayed at a time. Switch the screen as follows.

[Previous]: Display the previous 50 rows.

[Next]: Display the next 50 rows.

[Apply]: Enter the station number and click **[Apply]** to move the cursor to the row of the station number that was entered.

Move column

Up to 50 station number columns can be displayed at a time. Switch the screen as follows.

[Previous]: Display the previous 50 columns.

[Next]: Display the next 50 columns.

[Apply]: Enter the station number and click **[Apply]** to move the cursor to the column of the station number that was entered.

Row

Enter Station Number

Column

Enter Station Number

[Display settings]

Group Number

01

U = Unicast, M = Multicast
If designating "M", multicast IP addresses must be configured for the station(s).

| Building Number | Unit Number | Station Name | System Information | | | | System Information Required settings. | |
|-----------------|-------------|-----------------|--------------------|-----------------|----------------|-------|--|---|
| | | | Group | | | | Group | |
| | | | 01 | | | | 01 | |
| | | | Number | Name | Type | Total | Station Number / Station Name / Station Type | |
| 01 | 002 | Master Station1 | 01 | Commercial106 | Audio Protocol | 2 | | |
| | | | | | Video Protocol | 1 | | |
| 01 | 106 | Master Station1 | 01 | Inside Area 002 | Audio Protocol | 1 | | U |
| | | | | | Video Protocol | 0 | | |

! Important

- Always set "[Language \(→page 73\)](#)" before setting "Group."
- Enter using the language set in "[Language \(→page 73\)](#)". However, if the language (configured on the station main unit) displayed on the screen for IX-MV7-* is different from the language set with "[Language \(→page 73\)](#)", the characters displayed on the station screen may appear incorrectly. To avoid this, enter information using alphabetical characters only.
- A station cannot be registered to a group unless the "IP Address" settings have been configured in Administrator mode and the station has been registered in "[Station List \(→page 81\)](#)". In addition, units (Mobile App) which are not registered on "[Mobile App List \(→page 84\)](#)" cannot be registered to a group.
- Groups calls and contact input calls cannot be made to an Door Stations or Entrance Station.
- Results when searching by station will be listed in order of group number.

3.4.1 Configuring a Group

Configure the group to register in each station.

The screenshot shows a web-based configuration interface. At the top, there are 'Row' and 'Column' filter sections, each with a search box and an 'Apply' button. To the right of these is a 'Group Number' dropdown menu, which is highlighted with a red box and labeled '1'. Below this is a section for 'Group Information' with two input fields: 'Number' and 'Name', both highlighted with a red box and labeled '2'. To the left of the 'Group Information' section is a table titled 'List of IX-MV7-* in setting data', which is highlighted with a red box and labeled '3'. To the right of the 'Group Information' section is another table titled 'List of stations that can be registered to group', which is highlighted with a red box and labeled '4'. A red arrow points from the 'List of IX-MV7-* in setting data' table to the 'List of stations that can be registered to group' table. In the 'List of stations that can be registered to group' table, a dropdown menu is open, showing options 'U' and 'M', highlighted with a red box and labeled '5'. To the right of the 'List of stations that can be registered to group' table is a 'Mobile App' section with three 'Select' buttons, highlighted with a red box and labeled '6'. The interface also includes a 'System Information' section with 'Group' information and a 'Required settings' section.

1. Select the group to configure from "Group Number."
The Settings screen for the selected group will be shown on the screen.
2. Enter the following information in "Group Information."
 - Number: 01-99
Group numbers must be unique.
 - Name: 1-24 alphanumeric characters
3. Search for the station to be configured from "list of IX-MV7-* in setting data."
4. Search for the station to be registered from the "list of stations that can be registered to group."

- 5.** Click the cells that correspond to Steps 3 and 4. Select an audio protocol and video protocol setting value for each, and register to a group.

The number of registered stations will be displayed in "Total."

Audio Protocol

- Blank: Select to not register to a group.
- U: Register to group. Audio will be transmitted in unicast during group paging.
- M: Register to group. Audio will be transmitted in multicast during group paging.

Video protocol (only when IX-MV7-*or IXG-2C7(-*) is the station to register)

- Blank: Video will be transmitted as multicast.
- U: Video will be transmitted in unicast during group calls. Unicast can reach up to 20 stations.
- M: Video will be transmitted in multicast during group calls.

The video protocol pull-down menu is shown when the audio protocol setting is selected.

- 6.** To register a Mobile App to a group, click "Mobile App" - **[Select]**.

- 7.** Select the unit containing the Mobile App to register to the group.

- 8.** Click **[OK]**.
- Click **[Cancel]** to quit without registering a Mobile App.

- 9.** After configuration is complete, click **[Update]**.

- 10.** Click **[OK]**.



Important

- If "M" is selected, or if "Blank" is selected for the video protocol setting, be sure to configure "Multicast Address" in Administrator mode.



Note

- When making a group call, the audio protocol will be set to "U" and cannot be changed.

4. Call Settings (Move-in Settings)

4.1 Called Stations (Door/Sub Stations)

| | |
|-----------------|---|
| Compatible type | <input type="checkbox"/> IXG-2C7(-*) <input type="checkbox"/> IXG-MK <input type="checkbox"/> IX-MV7-* <input type="checkbox"/> IXG-DM7(-*) <input checked="" type="checkbox"/> IX-DA <input checked="" type="checkbox"/> IX-BA <input checked="" type="checkbox"/> IX-DV, IX-DVF(-*) <input checked="" type="checkbox"/> IX-SSA(-*) <input checked="" type="checkbox"/> IX-EA, IX-EAU <input checked="" type="checkbox"/> IX-FA <input type="checkbox"/> IXGW-LC <input type="checkbox"/> IXGW-GW <input type="checkbox"/> Intercom App |
|-----------------|---|

Configure the group to call when a call is made using the call button or via contact input.

- Except for IX-DA, IX-BA: Up to 20 stations can be added per group (when registering a Mobile App, 19 stations per group and a single unit containing the Mobile App), and up to 10 groups can be configured.
- IX-DA and IX-BA: Up to 20 stations can be added per group (when registering a Mobile App, 19 stations per group and a single unit containing the Mobile App), and only a single group can be configured.
- IXG-2C7(-*) and IX-MV7-* stations can be registered as destinations.

Move row

Up to 50 station number rows can be displayed at a time. Switch the screen as follows.

[Previous]: Display the previous 50 rows.

[Next]: Display the next 50 rows.

[Apply]: Enter the station number and click **[Apply]** to move the cursor to the row of the station number that was entered.

Move column

Up to 50 station number columns can be displayed at a time. Switch the screen as follows.

[Previous]: Display the previous 50 columns.

[Next]: Display the next 50 columns.

[Apply]: Enter the station number and click **[Apply]** to move the cursor to the column of the station number that was entered.

Move to Related Settings

Moves to the selected item within the same Settings screen.

1

2

3

4

5

List of Door Stations in setting data

List of stations that can be registered to group

| Building Number | Unit Number | Station Name | Total |
|-----------------|-------------|----------------|-------|
| 01 | 002 | Video Door Stn | 2 |
| 01 | 003 | Video Door Stn | 1 |
| 01 | 101 | Video Door Stn | 1 |
| 01 | 102 | Video Door Stn | 3 |
| 01 | 103 | Video Door Stn | 1 |
| 01 | 104 | Video Door Stn | 1 |
| 01 | 106 | Video Door Stn | 1 |
| 01 | 106 | Video Door Stn | 2 |
| 01 | 201 | Video Door Stn | 1 |
| 01 | 202 | Video Door Stn | 1 |
| 01 | 203 | Video Door Stn | 1 |
| 01 | 204 | Video Door Stn | 1 |
| 01 | 205 | Video Door Stn | 1 |
| 01 | 206 | Video Door Stn | 1 |

| Building Number | Unit Number | Unit Name | Select |
|-----------------|-------------|----------------|--------|
| 01 | 206 | Quart206 | Select |
| 01 | 101 | Residential101 | Select |
| 01 | 102 | Residential102 | Select |
| 01 | 106 | Commercial106 | Select |
| 01 | 106 | Commercial106 | Select |
| 01 | 106 | Commercial106 | Select |
| 01 | 106 | Commercial106 | Select |
| 01 | 106 | Commercial106 | Select |
| 01 | 106 | Commercial106 | Select |
| 01 | 106 | Commercial106 | Select |
| 01 | 206 | Quart206 | Select |

! Important

- A station cannot be registered as a destination unless "IP Address" has been configured for the station in Administrator mode.

How to configure destinations (Door/Sub Stations)

1. Select the group to configure from "Display settings."
 - The Settings screen for the selected group will be displayed.
 - When configuring IX-DA and IX-BA destinations, use "Group 10."
2. Search for the station to be configured from "list of Door Stations in setting data."
3. Search for the station to be registered from the "list of stations that can be registered to group."
4. Click the cells that correspond to Steps 2 and 3. Select the setting value and register to the group.
 - The number of registered stations will be displayed in "Total."
 - Blank: Select to not register to a group.
 - U: Register to group. Video and audio will be transmitted in unicast when making an outgoing call.
 - M: Register to group. Video transmitted in multicast and audio will be transmitted in unicast when making an outgoing call.
 - This can only be configured if the station to configure is IX-DV, IX-DVF(-*), IX-DA, IX-EA, or IX-EAU, and the destination is IX-MV7-* or IXG-2C7(-*).
5. To register a Mobile App to a group, click "Mobile App" - **[Select]**.
6. Select the unit containing the Mobile App to register to the group.

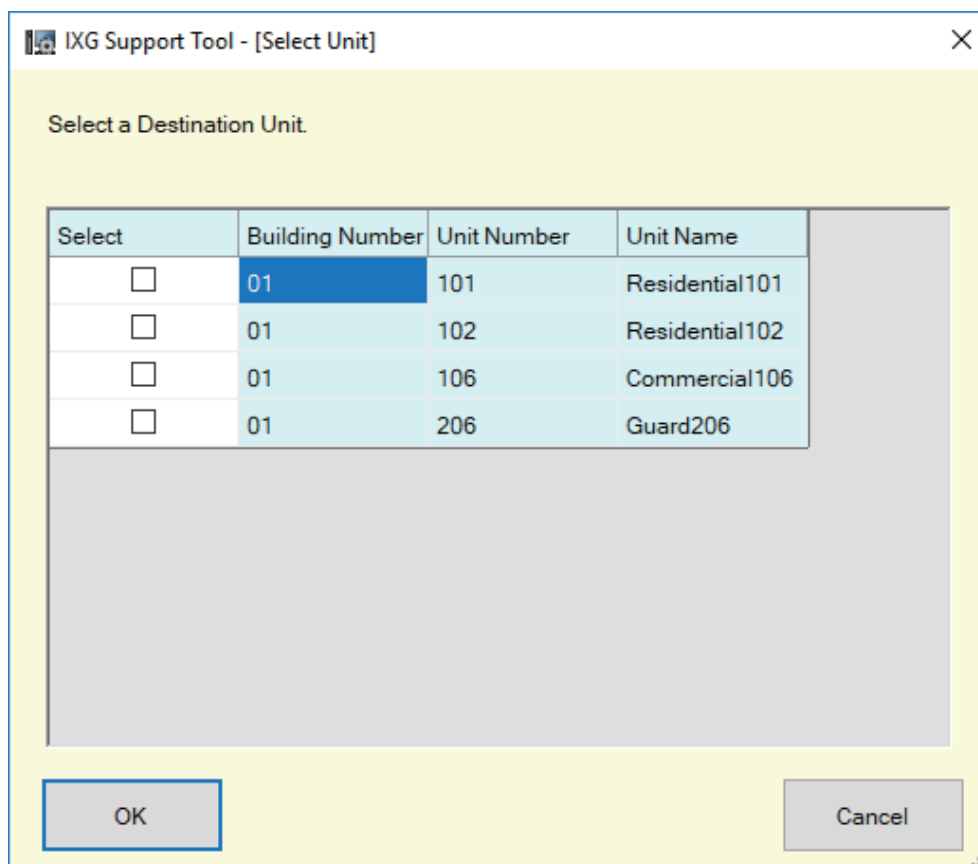

7. Click **[OK]**.
 - Click **[Cancel]** to quit without registering a Mobile App.
8. After configuration is complete, click **[Update]**.
9. Click **[OK]**.

 **Important**

- If "M" is selected, be sure to configure "Multicast Address" in Administrator mode.

4.2 Guard Button (IXG-2C7)

Configure the station to be called when the "Guard Call Button" is pressed on the Tenant Station. IX-MV7-* stations can be set as destinations.

| | | | Call Settings Required settings. | | | | | | | | | |
|-----------------|-------------|----------------|---|----------------|-----------------|-------------|----------------|----------------|-----------------|-------------|--------------|--|
| Building Number | Unit Number | Unit Name | Guard Button (IXG-2C7) | | | | | | | | | |
| | | | Select Station | Button Number1 | | | Button Number2 | | | | | |
| | | | | Station Number | Building Number | Unit Number | Station Name | Station Number | Building Number | Unit Number | Station Name | |
| 01 | 101 | Residential101 | ... | | | | | | | | | |
| 01 | 102 | Residential102 | ... | | | | | | | | | |
| 01 | 103 | Residential103 | ... | | | | | | | | | |
| 01 | 104 | Residential104 | ... | | | | | | | | | |
| 01 | 105 | Residential105 | ... | | | | | | | | | |

! Important

- A station cannot be set as a destination unless "IP Address" has been configured for the station in Administrator mode.

■ Select Station

| | |
|-----------------|--|
| Compatible type | <input checked="" type="checkbox"/> IXG-2C7(-*) <input type="checkbox"/> IXG-MK <input type="checkbox"/> IX-MV7-* <input type="checkbox"/> IXG-DM7(-*) <input type="checkbox"/> IX-DA <input type="checkbox"/> IX-BA <input type="checkbox"/> IX-DV, IX-DVF(-*) <input type="checkbox"/> IX-SSA(-*) <input type="checkbox"/> IX-EA, IX-EAU <input type="checkbox"/> IX-FA <input type="checkbox"/> IXGW-LC <input type="checkbox"/> IXGW-GW <input type="checkbox"/> Intercom App |
| Description | Configure the call destination station (the station number). Up to 8 call destination stations can be configured. Enter the station number or click [Select] to select one. The information (building number, unit number, station name) for the configured station will be displayed. |
| Settings | Multiple Building System: 3-24 digits Single Building System: 3-5 digits |

■ Mobile App

| | |
|-----------------|--|
| Compatible type | <input checked="" type="checkbox"/> IXG-2C7(-*) <input type="checkbox"/> IXG-MK <input type="checkbox"/> IX-MV7-* <input type="checkbox"/> IXG-DM7(-*) <input type="checkbox"/> IX-DA <input type="checkbox"/> IX-BA <input type="checkbox"/> IX-DV, IX-DVF(-*) <input type="checkbox"/> IX-SSA(-*) <input type="checkbox"/> IX-EA, IX-EAU <input type="checkbox"/> IX-FA <input type="checkbox"/> IXGW-LC <input type="checkbox"/> IXGW-GW <input type="checkbox"/> Intercom App |
| Description | Select the unit containing the Mobile App to configure as a destination. Up to 1 destination unit can be configured. Enter the building number and unit number of the unit containing the Mobile App, or click [Select] to select it. The information (building number, unit number, unit name) for the configured Mobile App is displayed. |
| Settings | Building Number: 01-99 Unit Number: 3-4 digits (Single Building System), 3-10 digits (Multiple Building System) |

5. Move-out Settings (Move-out Settings)

5.1 Resident Move-out

Prevent previous residents from using the Mobile App once they have moved out.
Send a QR code for new residents to the registered Tenant Station.

| Move-out Settings Required settings. | | | | | | | | |
|---|-------------|----------------|--------------------------|----------------|-----------------|--------------------------|-----------------|----------------|
| Resident Move-out | | | | | | | | |
| Building Number | Unit Number | Unit Name | Select | Station Number | Station Name | Initialize User Settings | Deactivate Apps | Upload QR Code |
| 01 | 101 | Residential101 | <input type="checkbox"/> | 1010 | Tenant Station1 | - | - | - |
| 01 | 101 | Residential101 | <input type="checkbox"/> | 1011 | Tenant Station2 | - | - | - |
| 01 | 102 | Residential102 | <input type="checkbox"/> | 1020 | Tenant Station1 | - | - | - |
| 01 | 102 | Residential102 | <input type="checkbox"/> | 1021 | Tenant Station2 | - | - | - |
| 01 | 103 | Residential103 | <input type="checkbox"/> | 1030 | Tenant Station1 | - | - | - |
| 01 | 104 | Residential104 | <input type="checkbox"/> | 1040 | Tenant Station1 | - | - | - |
| 01 | 105 | Residential105 | <input type="checkbox"/> | 1050 | Tenant Station1 | - | - | - |
| 01 | 201 | Residential201 | <input type="checkbox"/> | 2010 | Tenant Station1 | - | - | - |
| 01 | 202 | Residential202 | <input type="checkbox"/> | 2020 | Tenant Station1 | - | - | - |
| 01 | 203 | Residential203 | <input type="checkbox"/> | 2030 | Tenant Station1 | - | - | - |
| 01 | 204 | Residential204 | <input type="checkbox"/> | 2040 | Tenant Station1 | - | - | - |
| 01 | 205 | Residential205 | <input type="checkbox"/> | 2050 | Tenant Station1 | - | - | - |

List of Residential Unit

How to perform Resident Move-out

1. In the "List of residences in the setting data," select the unit for which to perform the move-out process.
2. Click **[Resident Move-out]**.
3. Click **[OK]**.
 - Click **[Cancel]** to quit without performing the move-out process.
4. Enter the "IXG Cloud Server ID" and "Password."
5. Click "Login."
 - Login to IXG Cloud Server.
 - Click **[Cancel]** to quit without performing IXG Cloud Server Login.

The following processes will be performed.

- Initialize User Settings: The user settings of the Tenant Station will be initialized.
- Deactivate Apps: The previous residents will not be able to use the App.
- Upload QR Code: Upload a new QR code to the Tenant Station.

6. Click **[OK]**.
7. If there is no Tenant Station, generate a PDF of the QR Code for App Registration.
["Export QR Code for App Registration \(→page 65\)"](#)

5.2 Delete Unit Information

Delete the unit information if necessary, such as when a resident moves out.

Unit Information and registered App will be deleted.

| Select | Building Number | Unit Number | Move-out Settings | | |
|--------------------------|-----------------|-------------|-------------------------|------------|-----------|
| | | | Delete Unit Information | | |
| | | | Unit Name | First Name | Last Name |
| <input type="checkbox"/> | 01 | 101 | Residential101 | Derek | McNeill |
| <input type="checkbox"/> | 01 | 102 | Residential102 | Sean | Peterson |
| <input type="checkbox"/> | 01 | 103 | Residential103 | John | Ford |
| <input type="checkbox"/> | 01 | 104 | Residential104 | Jordana | Kidd |
| <input type="checkbox"/> | 01 | 105 | Residential105 | Joy | Sweet |
| <input type="checkbox"/> | 01 | 201 | Residential201 | aiphone | |
| <input type="checkbox"/> | 01 | 202 | Residential202 | aiphone | |
| <input type="checkbox"/> | 01 | 203 | Residential203 | | |

List of Residential information in the setting data

How to delete unit information

1. In the "List of Residential information in the setting data," select the unit for which to delete the unit information.
2. Click **[Delete]**.
 - "Unit Name," "First Name," and "Last Name" will be blank.
3. Click **[Update]**.
 - "Unit Name," "First Name," and "Last Name" will be returned to their default values.
4. Click **[OK]**.

6. Entrance Station Settings (Misc.)

6.1 Access Code

Set the access code for each unit used at the Entrance Station to open the door.

Filter
 Building Number / Building Name: Select the building to display.
 Station Number / Station Name: Select the station to display and then click **[Apply]**. The access codes for each unit will be displayed.

Length: length of access codes.

["Add Access Code \(→page 101\)"](#)

["Delete Access Code \(→page 102\)"](#)

Filter

Building Number / Building Name Apply

Station Number / Station Name

Length

Add Access Code

Delete Access Code

| Building Number | Unit Number | Unit Name | Entrance Station Settings | | | <small>Required settings.</small> |
|-----------------|-------------|------------------|---------------------------|----------------|----------------|-----------------------------------|
| | | | Access Code | Access Code | | |
| | | | | Relay Output 1 | Relay Output 2 | |
| 01 | 002 | Inside Area 002 | | | | |
| 01 | 003 | Outside Area 003 | | | | |
| 01 | 101 | Residential101 | | | | |
| 01 | 102 | Residential102 | | | | |
| 01 | 103 | Residential103 | | | | |
| 01 | 104 | Residential104 | | | | |
| 01 | 105 | Residential105 | | | | |
| 01 | 106 | Commercial106 | | | | |
| 01 | 201 | Residential201 | | | | |
| 01 | 202 | Residential202 | | | | |
| 01 | 203 | Residential203 | | | | |
| 01 | 204 | Residential204 | | | | |
| 01 | 205 | Residential205 | | | | |

How to configure access codes

1. Use "Filter" to select the Entrance Station for which to configure an access code, and then click **[Apply]**.
 - The Settings screen for the selected Entrance Station will be displayed.

2. Enter the access code for each unit.
 - Access Code: Configure using the number of digits displayed in "Length."
 - If "Door Release" was set for Relay Output 1 of the Entrance Station in "Relay Output" - "Function" in Administrator mode, enter "A"+"Access Code" when releasing the door using the Entrance Station.
 - If "Door Release" was set for Relay Output 2 of the Entrance Station in "Relay Output" - "Function" in Administrator mode, enter "B"+"Access Code" when releasing the door using the Entrance Station.

Filter

Building Number / Building Name Apply

Station Number / Station Name

Length

Add Access Code Delete Access Code

| Building Number | Unit Number | Unit Name | Entrance Station Settings | | | Required settings. |
|-----------------|-------------|------------------|---------------------------|----------------|----------------|---|
| | | | Access Code | Access Code | | |
| | | | | Relay Output 1 | Relay Output 2 | |
| 01 | 002 | Inside Area 002 | 1111 | A1111 | | |
| 01 | 003 | Outside Area 003 | | | | |
| 01 | 101 | Residential101 | | | | |
| 01 | 102 | Residential102 | | | | |
| 01 | 103 | Residential103 | | | | |
| 01 | 104 | Residential104 | | | | |
| 01 | 105 | Residential105 | | | | |
| 01 | 106 | Commercial106 | | | | |
| 01 | 201 | Residential201 | | | | |
| 01 | 202 | Residential202 | | | | |
| 01 | 203 | Residential203 | | | | |

3. Click **[Update]**.
4. Click **[OK]**.

6.1.1 Add Access Code

Configure the access code for each unit.

Click **[Add Access Code]**. The "Add Access Code" screen will be displayed.

IXG Support Tool - [Add Access Code]

Access Code

Select a Unit to associate to this Access Code.

Building Number

Unit Number

Select Entrances to release the door by this Access Code.

| Select | Building Number | Unit Number | Station Name | Length |
|--------------------------|-----------------|-------------|---------------------|--------|
| <input type="checkbox"/> | 01 | 001 | Entrance Station1 4 | 4 |

Required settings.

Add Cancel

■ How to add Access Codes

1. Enter the "Access Code."
 - Access Code: Configure using the number of digits set in Step 2 of ["How to configure access codes \(→page 99\)"](#).
2. Select the "Building Number" of the unit to assign the access code, and then enter the "Unit Number."
3. Select the Entrance Station where to add the access code. (Multiple selections allowed.)
4. Click **[Add]**.
 - Click **[Cancel]** to exit.
5. Click **[Update]**.
6. Click **[OK]**.

 **Note**

- To confirm the configured access codes, use "Filter" to select the "Building Number / Building Name" and "Station Number / Station Name" for the Entrance Station, and then click **[Apply]**.

6.1.2 Delete Access Code

Delete registered access codes.

Click **[Delete Access Code]**. The "Delete Access Code" screen will be displayed.

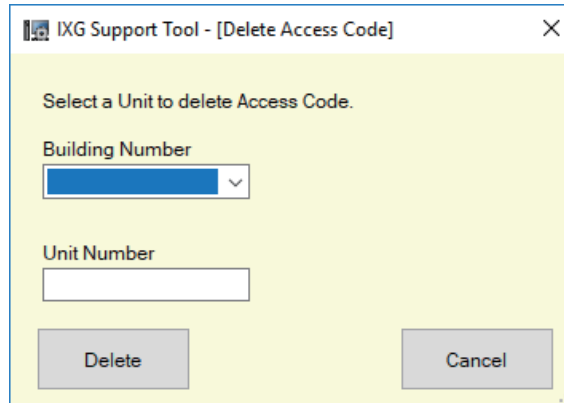

■ How to delete access codes

1. Select the "Building Number" of the unit to delete an access code, and then enter the "Unit Number."
2. Click **[Delete]**.
 - Click **[Cancel]** to exit.
3. Click **[Update]**.
4. Click **[OK]**.

 **Note**

- To confirm whether an access code was deleted, use "Filter" to select the "Building Number / Building Name" and "Station Number / Station Name" for the Entrance Station, and then click **[Apply]**.

6.2 Welcome Screen

An image may be set as a Welcome Screen to be displayed prior to seeing the operation screen.

| Building Number | Unit Number | Station Name | Entrance Station Settings | | | | Required settings. |
|-----------------|-------------|-------------------|-------------------------------------|--------------------------|--|-----|--------------------------|
| | | | Welcome Screen Settings | | | | |
| | | | Welcome Screen Wallpaper | Image1 | | | |
| Display | File name | ... | | Delete | | | |
| 01 | 001 | Entrance Station1 | <input checked="" type="checkbox"/> | <input type="checkbox"/> | | ... | <input type="checkbox"/> |

6.2.1 Welcome Screen Wallpaper

| | |
|-----------------|--|
| Compatible type | <input type="checkbox"/> IXG-2C7(-*) <input type="checkbox"/> IXG-MK <input type="checkbox"/> IX-MV7-* <input checked="" type="checkbox"/> IXG-DM7(-*) <input type="checkbox"/> IX-DA <input type="checkbox"/> IX-BA <input type="checkbox"/> IX-DV, IX-DVF(-*) <input type="checkbox"/> IX-SSA(-*) <input type="checkbox"/> IX-EA, IX-EAU <input type="checkbox"/> IX-FA <input type="checkbox"/> IXGW-LC <input type="checkbox"/> IXGW-GW <input type="checkbox"/> Intercom App |
| Description | Configure whether to display the Welcome Screen. |
| Settings | <ul style="list-style-type: none"> • Checked: Enable • Unchecked: Disable |

6.2.2 Image 1

Register the image to display if "Checked: Enable" was set in "Welcome Screen Wallpaper."
If no image is registered, the default Welcome Screen will be displayed.

■ Display

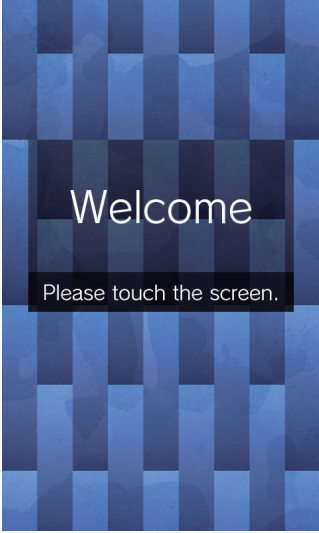
| | |
|-----------------|--|
| Compatible type | <input type="checkbox"/> IXG-2C7(-*) <input type="checkbox"/> IXG-MK <input type="checkbox"/> IX-MV7-* <input checked="" type="checkbox"/> IXG-DM7(-*) <input type="checkbox"/> IX-DA <input type="checkbox"/> IX-BA <input type="checkbox"/> IX-DV, IX-DVF(-*) <input type="checkbox"/> IX-SSA(-*) <input type="checkbox"/> IX-EA, IX-EAU <input type="checkbox"/> IX-FA <input type="checkbox"/> IXGW-LC <input type="checkbox"/> IXGW-GW <input type="checkbox"/> Intercom App |
| Description | Configure whether to display the registered image on the Welcome Screen. Only a single image file can be displayed.  |
| Settings | <ul style="list-style-type: none"> • Checked: Enable • Unchecked: Disable |

■ File name

| | |
|-----------------|--|
| Compatible type | <input type="checkbox"/> IXG-2C7(-*) <input type="checkbox"/> IXG-MK <input type="checkbox"/> IX-MV7-* <input checked="" type="checkbox"/> IXG-DM7(-*) <input type="checkbox"/> IX-DA <input type="checkbox"/> IX-BA <input type="checkbox"/> IX-DV, IX-DVF(-*) <input type="checkbox"/> IX-SSA(-*) <input type="checkbox"/> IX-EA, IX-EAU <input type="checkbox"/> IX-FA <input type="checkbox"/> IXGW-LC <input type="checkbox"/> IXGW-GW <input type="checkbox"/> Intercom App |
| Description | Register an image to display on the Welcome Screen. <ul style="list-style-type: none"> • Message File Name: Up to 64 bytes of alphanumeric characters (including extension) • File format: PNG • Resolution: <ul style="list-style-type: none"> Width: 480 pixels Height: 800 pixels |
| Settings | OK: Click [Browse] to select a file. To delete, place a check next to the [Delete] box. |

7. Transfer Settings (Misc.)

7.1 Absent Transfer

Configure the settings for absent transfer.

Absent Transfer: If an incoming call is received during absent transfer, the incoming call can be automatically transferred to a transfer destination.

Move row

Up to 50 station number rows can be displayed at a time. Switch the screen as follows.

[Previous]: Display the previous 50 rows.

[Next]: Display the next 50 rows.

[Apply]: Enter the station number and click **[Apply]** to move the cursor to the row of the station number that was entered.

| Building Number | Unit Number | Station Name | Transfer Settings | | | | | | | | | | Required settings. | |
|-----------------|-------------|-----------------|-------------------|---------------------------|-------|-------|-------|-------|-------|-------|-------|-------|--------------------|--|
| | | | Absent Transfer | Absent Transfer | | | | | | | | | | |
| | | | | Transfer Destination List | | | | | | | | | | |
| | | Select Station | Station Number | | | | | | | | | | Mobile App | |
| | | | No.01 | No.02 | No.03 | No.04 | No.05 | No.06 | No.07 | No.08 | No.09 | No.10 | Building Number | |
| 01 | 002 | Master Station1 | Disable | Select Station | | | | | | | | | | |
| 01 | 106 | Master Station1 | Disable | Select Station | | | | | | | | | | |

! Important

- A station cannot be set as a transfer destination unless "IP Address" has been configured for the station in Administrator mode.

■ Absent Transfer

| | |
|-----------------|---|
| Compatible type | <input type="checkbox"/> IXG-2C7(-*) <input type="checkbox"/> IXG-MK <input checked="" type="checkbox"/> IX-MV7-* <input type="checkbox"/> IXG-DM7(-*) <input type="checkbox"/> IX-DA <input type="checkbox"/> IX-BA <input type="checkbox"/> IX-DV, IX-DVF(-*) <input type="checkbox"/> IX-SSA(-*) <input type="checkbox"/> IX-EA, IX-EAU <input type="checkbox"/> IX-FA <input type="checkbox"/> IXGW-LC <input type="checkbox"/> IXGW-GW <input type="checkbox"/> Intercom App |
| Description | Configure whether to set absent transfer. The setting can also be changed using the button on the station main unit. If "Transfer Destination List" is not configured, this cannot be set to "Enable." |
| Settings | <ul style="list-style-type: none"> • Enable: Set absent transfer. • Disable: Do not set absent transfer. |

Transfer Destination List

| | |
|-----------------|--|
| Compatible type | <input type="checkbox"/> IXG-2C7(-*) <input type="checkbox"/> IXG-MK <input checked="" type="checkbox"/> IX-MV7-* <input type="checkbox"/> IXG-DM7(-*) <input type="checkbox"/> IX-DA <input type="checkbox"/> IX-BA <input type="checkbox"/> IX-DV, IX-DVF(-*) <input type="checkbox"/> IX-SSA(-*) <input type="checkbox"/> IX-EA, IX-EAU <input type="checkbox"/> IX-FA <input type="checkbox"/> IXGW-LC <input type="checkbox"/> IXGW-GW <input type="checkbox"/> Intercom App |
| Description | <p>Configure the transfer destination station (station number) and Mobile App when performing absent transfer. Up to 10 stations can be configured as transfer destinations (when registering a Mobile App, 9 stations and a single unit containing the Mobile App). However, if the call originating station is IX-DA or IX-BA, calls will only be transferred to the station entered for "No.01."</p> <p>To configure a station, enter the station number or click [Select Station] to select one.</p> <p>To configure a Mobile App, click "Mobile App" - [Select]. Select the unit containing the Mobile App to register as a transfer destination, and then click [OK].</p> |
| Settings | <p>Multiple building system: 3-24 digits</p> <p>Single building system: 3-5 digits</p> |

 **Note**

- To register a "Mobile App," first register the "Mobile App" in ["Mobile App List \(→page 84\)"](#). A "Mobile App" registered in a "Mobile App List" can be registered as a transfer destination "Mobile App."

Re-Transfer Destination

| | |
|-----------------|---|
| Compatible type | <input type="checkbox"/> IXG-2C7(-*) <input type="checkbox"/> IXG-MK <input checked="" type="checkbox"/> IX-MV7-* <input type="checkbox"/> IXG-DM7(-*) <input type="checkbox"/> IX-DA <input type="checkbox"/> IX-BA <input type="checkbox"/> IX-DV, IX-DVF(-*) <input type="checkbox"/> IX-SSA(-*) <input type="checkbox"/> IX-EA, IX-EAU <input type="checkbox"/> IX-FA <input type="checkbox"/> IXGW-LC <input type="checkbox"/> IXGW-GW <input type="checkbox"/> Intercom App |
| Description | <p>Configure the transfer destination station (station number) and Mobile App when performing absent transfer again for a transferred call. Only a single station can be configured as a transfer destination. However, if the call originating station is IX-DA or IX-BA, the call will arrive without being retransferred.</p> <p>To configure a station, enter the station number or click [Select Station] to select one.</p> <p>To configure a Mobile App, click "Mobile App" - [Select]. Select the unit containing the Mobile App to register as a transfer destination, and then click [OK].</p> |
| Settings | <p>Multiple building system: 3-24 digits</p> <p>Single building system: 3-5 digits</p> |

 **Note**

- To register a "Mobile App," first register the "Mobile App" in ["Mobile App List \(→page 84\)"](#). A "Mobile App" registered in a "Mobile App List" can be registered as a transfer destination "Mobile App."
- When configuring a Entrance Station or Door Station as a transfer destination, configure only a single Entrance Station or Door Station. If multiple stations are configured, calls will not be transferred to the Entrance Station or Door Station.

7.2 Delay Transfer

Configure the settings for delay transfer.

Delay Transfer: If an incoming call is received during delay transfer, the call can be automatically transferred to the transfer destination after a certain period of time (the set delay time) elapses with no response.

Move row

Up to 50 station number rows can be displayed at a time. Switch the screen as follows.

[Previous]: Display the previous 50 rows.

[Next]: Display the next 50 rows.

[Apply]: Enter the station number and click **[Apply]** to move the cursor to the row of the station number that was entered.

| Building Number | Unit Number | Station Name | Transfer Settings | | | | Transfer Destination List | | | | | | | | | | Mobile App | |
|-----------------|-------------|------------------|-------------------|------------------|----------------|----------------|---------------------------|-------|-------|-------|-------|-------|-------|-------|-------|-------|------------|-----------------|
| | | | Delay Transfer | Delay Time [sec] | Select Station | Station Number | No.01 | No.02 | No.03 | No.04 | No.05 | No.06 | No.07 | No.08 | No.09 | No.10 | | Building Number |
| 01 | 002 | Master Station 1 | Disable | 30 | Select Station | | | | | | | | | | | | | |
| 01 | 106 | Master Station 1 | Disable | 30 | Select Station | | | | | | | | | | | | | |

! Important

- A station cannot be set as a transfer destination unless "IP Address" has been configured for the station in Administrator mode.

■ Delay Transfer

| | |
|-----------------|---|
| Compatible type | <input type="checkbox"/> IXG-2C7(-*) <input type="checkbox"/> IXG-MK <input checked="" type="checkbox"/> IX-MV7-* <input type="checkbox"/> IXG-DM7(-*) <input type="checkbox"/> IX-DA <input type="checkbox"/> IX-BA <input type="checkbox"/> IX-DV, IX-DVF(-*) <input type="checkbox"/> IX-SSA(-*) <input type="checkbox"/> IX-EA, IX-EAU <input type="checkbox"/> IX-FA <input type="checkbox"/> IXGW-LC <input type="checkbox"/> IXGW-GW <input type="checkbox"/> Intercom App |
| Description | Select Enable / Disable for Delay Transfer. If "Transfer Destination List" is not configured, this cannot be set to "Enable." |
| Settings | <ul style="list-style-type: none"> • Enable: Delay transfer enabled. • Disable: Delay transfer disabled. |

■ Delay Time [sec]◆

| | |
|-----------------|---|
| Compatible type | <input type="checkbox"/> IXG-2C7(-*) <input type="checkbox"/> IXG-MK <input checked="" type="checkbox"/> IX-MV7-* <input type="checkbox"/> IXG-DM7(-*) <input type="checkbox"/> IX-DA <input type="checkbox"/> IX-BA <input type="checkbox"/> IX-DV, IX-DVF(-*) <input type="checkbox"/> IX-SSA(-*) <input type="checkbox"/> IX-EA, IX-EAU <input type="checkbox"/> IX-FA <input type="checkbox"/> IXGW-LC <input type="checkbox"/> IXGW-GW <input type="checkbox"/> Intercom App |
| Description | Set the delay time between receiving and transferring a call. |
| Settings | 1-300 seconds (by 1 sec.) |

Transfer Destination List

| | |
|-----------------|---|
| Compatible type | <input type="checkbox"/> IXG-2C7(-*) <input type="checkbox"/> IXG-MK <input checked="" type="checkbox"/> IX-MV7-* <input type="checkbox"/> IXG-DM7(-*) <input type="checkbox"/> IX-DA <input type="checkbox"/> IX-BA <input type="checkbox"/> IX-DV, IX-DVF(-*) <input type="checkbox"/> IX-SSA(-*) <input type="checkbox"/> IX-EA, IX-EAU <input type="checkbox"/> IX-FA <input type="checkbox"/> IXGW-LC <input type="checkbox"/> IXGW-GW <input type="checkbox"/> Intercom App |
| Description | <p>Configure the transfer destination station (station number) and Mobile App when performing delay transfer. Up to 10 stations can be configured as transfer destinations (when registering a Mobile App, 9 stations and a single unit containing the Mobile App). However, if the call originating station is IX-DA or IX-BA, calls will only be transferred to the station entered for "No.01."</p> <p>To configure a station, enter the station number or click [Select Station] to select one. To configure a Mobile App, click "Mobile App" - [Select]. Select the unit containing the Mobile App to register as a transfer destination, and then click [OK].</p> |
| Settings | Multiple building system: 3-24 digits Single building system: 3-5 digits |

 **Note**

- To register a "Mobile App," first register the "Mobile App" in ["Mobile App List \(→page 84\)"](#). A "Mobile App" registered in a "Mobile App List" can be registered as a transfer destination "Mobile App."

Re-Transfer Destination

| | |
|-----------------|--|
| Compatible type | <input type="checkbox"/> IXG-2C7(-*) <input type="checkbox"/> IXG-MK <input checked="" type="checkbox"/> IX-MV7-* <input type="checkbox"/> IXG-DM7(-*) <input type="checkbox"/> IX-DA <input type="checkbox"/> IX-BA <input type="checkbox"/> IX-DV, IX-DVF(-*) <input type="checkbox"/> IX-SSA(-*) <input type="checkbox"/> IX-EA, IX-EAU <input type="checkbox"/> IX-FA <input type="checkbox"/> IXGW-LC <input type="checkbox"/> IXGW-GW <input type="checkbox"/> Intercom App |
| Description | <p>Configure the transfer destination station (station number) and Mobile App when performing delay transfer again for a transferred call. Only a single station can be configured as a transfer destination. However, if the call originating station is IX-DA or IX-BA, the call will arrive without being retransferred.</p> <p>To configure a station, enter the station number or click [Select Station] to select one. To configure a Mobile App, click "Mobile App" - [Select]. Select the unit containing the Mobile App to register as a transfer destination, and then click [OK].</p> |
| Settings | Multiple building system: 3-24 digits Single building system: 3-5 digits |

 **Note**

- To register a "Mobile App," first register the "Mobile App" in ["Mobile App List \(→page 84\)"](#). A "Mobile App" registered in a "Mobile App List" can be registered as a transfer destination "Mobile App."
- When configuring a Entrance Station or Door Station as a transfer destination, configure only a single Entrance Station or Door Station. If multiple stations are configured, calls will not be transferred to the Entrance Station or Door Station.

7.3 Schedule Transfer

Configure the settings for Schedule Transfer.

Schedule Transfer: A call can be automatically transferred to a transfer destination when an incoming call is received during the time period set in [“Weekly Schedule \(→page 110\)”](#) and [“Daily Schedule \(→page 113\)”](#).

Move row

Up to 50 station number rows can be displayed at a time. Switch the screen as follows.

[Previous]: Display the previous 50 rows.

[Next]: Display the next 50 rows.

[Apply]: Enter the station number and click **[Apply]** to move the cursor to the row of the station number that was entered.

Weekly schedule

Select the day and schedule range to configure. The Settings screen will be shown.

[“Weekly Schedule \(→page 110\)”](#)

[“Daily Schedule \(→page 113\)”](#)

Move to Related Settings

Moves to the selected item within the same Settings screen.



Important

- A station cannot be set as a transfer destination unless "IP Address" has been configured for the station in Administrator mode.
- Incoming calls will be transferred during the time period set in "Schedule Transfer," regardless of the settings in [“Absent Transfer \(→page 105\)”](#) and [“Delay Transfer \(→page 107\)”](#).

■ Schedule Transfer

| | |
|-----------------|--|
| Compatible type | <input type="checkbox"/> IXG-2C7(-*) <input type="checkbox"/> IXG-MK <input checked="" type="checkbox"/> IX-MV7-* <input type="checkbox"/> IXG-DM7(-*) <input type="checkbox"/> IX-DA <input type="checkbox"/> IX-BA <input type="checkbox"/> IX-DV, IX-DVF(-*) <input type="checkbox"/> IX-SSA(-*) <input type="checkbox"/> IX-EA, IX-EAU <input type="checkbox"/> IX-FA <input type="checkbox"/> IXGW-LC <input type="checkbox"/> IXGW-GW <input type="checkbox"/> Intercom App |
| Description | Select Enable / Disable for Schedule Transfer. If “Weekly Schedule (→page 110)” or “Daily Schedule (→page 113)” is not configured, this cannot be set to "Enable." |
| Settings | Enable: Schedule transfer enabled. Disable: Schedule transfer disabled. |

7.3.1 Weekly Schedule

Configure the transfer destination and transfer time for every day from Sunday through Saturday. 12 schedules can be set for each day.

Transfer Destination List

| | |
|-----------------|--|
| Compatible type | <input type="checkbox"/> IXG-2C7(-*) <input type="checkbox"/> IXG-MK <input checked="" type="checkbox"/> IX-MV7-* <input type="checkbox"/> IXG-DM7(-*) <input type="checkbox"/> IX-DA <input type="checkbox"/> IX-BA <input type="checkbox"/> IX-DV, IX-DVF(-*) <input type="checkbox"/> IX-SSA(-*) <input type="checkbox"/> IX-EA, IX-EAU <input type="checkbox"/> IX-FA <input type="checkbox"/> IXGW-LC <input type="checkbox"/> IXGW-GW <input type="checkbox"/> Intercom App |
| Description | Configure the transfer destination station (station number) and Mobile App when performing schedule transfer. <ul style="list-style-type: none"> Up to 10 stations can be configured as transfer destinations for each of 12 day schedules (when registering a Mobile App, 9 stations and a single unit containing the Mobile App). However, if the call originating station is IX-DA or IX-BA, calls will only be transferred to the station entered for "No.01." To configure a station, enter the station number or click [Select Station] to select one. To configure a Mobile App, click "Mobile App" - [Select] . Select the unit containing the Mobile App to register as a transfer destination, and then click [OK] . |
| Settings | Multiple building system: 3-24 digits Single building system: 3-5 digits |

Note

- To register a "Mobile App," first register the "Mobile App" in "[Mobile App List \(→page 84\)](#)". A "Mobile App" registered in a "Mobile App List" can be registered as a transfer destination "Mobile App."

Re-Transfer Destination

| | |
|-----------------|---|
| Compatible type | <input type="checkbox"/> IXG-2C7(-*) <input type="checkbox"/> IXG-MK <input checked="" type="checkbox"/> IX-MV7-* <input type="checkbox"/> IXG-DM7(-*) <input type="checkbox"/> IX-DA <input type="checkbox"/> IX-BA <input type="checkbox"/> IX-DV, IX-DVF(-*) <input type="checkbox"/> IX-SSA(-*) <input type="checkbox"/> IX-EA, IX-EAU <input type="checkbox"/> IX-FA <input type="checkbox"/> IXGW-LC <input type="checkbox"/> IXGW-GW <input type="checkbox"/> Intercom App |
| Description | Configure the transfer destination station (station number) and Mobile App when performing schedule transfer again for a transferred call. Only a single station can be configured as a transfer destination for each of the 12 day schedules. However, if the call originating station is IX-DA or IX-BA, the call will arrive without being retransferred. To configure a station, enter the station number or click [Select Station] to select one. To configure a Mobile App, click "Mobile App" - [Select] . Select the unit containing the Mobile App to register as a transfer destination, and then click [OK] . |
| Settings | Multiple building system: 3-24 digits Single building system: 3-5 digits |

Note

- To register a "Mobile App," first register the "Mobile App" in "[Mobile App List \(→page 84\)](#)".
A "Mobile App" registered in a "Mobile App List" can be registered as a transfer destination "Mobile App."

■ Start Time

| | |
|-----------------|--|
| Compatible type | <input type="checkbox"/> IXG-2C7(-*) <input type="checkbox"/> IXG-MK <input checked="" type="checkbox"/> IX-MV7-* <input type="checkbox"/> IXG-DM7(-*) <input type="checkbox"/> IX-DA <input type="checkbox"/> IX-BA <input type="checkbox"/> IX-DV, IX-DVF(-*) <input type="checkbox"/> IX-SSA(-*) <input type="checkbox"/> IX-EA, IX-EAU <input type="checkbox"/> IX-FA <input type="checkbox"/> IXGW-LC <input type="checkbox"/> IXGW-GW <input type="checkbox"/> Intercom App |
| Description | Set the Start Time to enable schedule transfer. |
| Settings | 00:00 - 23:59 |

■ End Time

| | |
|-----------------|--|
| Compatible type | <input type="checkbox"/> IXG-2C7(-*) <input type="checkbox"/> IXG-MK <input checked="" type="checkbox"/> IX-MV7-* <input type="checkbox"/> IXG-DM7(-*) <input type="checkbox"/> IX-DA <input type="checkbox"/> IX-BA <input type="checkbox"/> IX-DV, IX-DVF(-*) <input type="checkbox"/> IX-SSA(-*) <input type="checkbox"/> IX-EA, IX-EAU <input type="checkbox"/> IX-FA <input type="checkbox"/> IXGW-LC <input type="checkbox"/> IXGW-GW <input type="checkbox"/> Intercom App |
| Description | Configure the time at which to end schedule transfer. If set earlier than "Start Time," the end time will be the time the following day. |
| Settings | 00:00 - 23:59 |



Note

- When configuring a Entrance Station or Door Station as a transfer destination, configure only a single Entrance Station or Door Station. If multiple stations are configured, calls will not be transferred to the Entrance Station or Door Station.

How to configure schedule display

Configure the day and schedule range shown on the Settings screen for the weekly schedule.

The display can be filtered to show only the day and schedule to configure.

Click **[Schedule View Adjustment]**. The following screen will be shown.

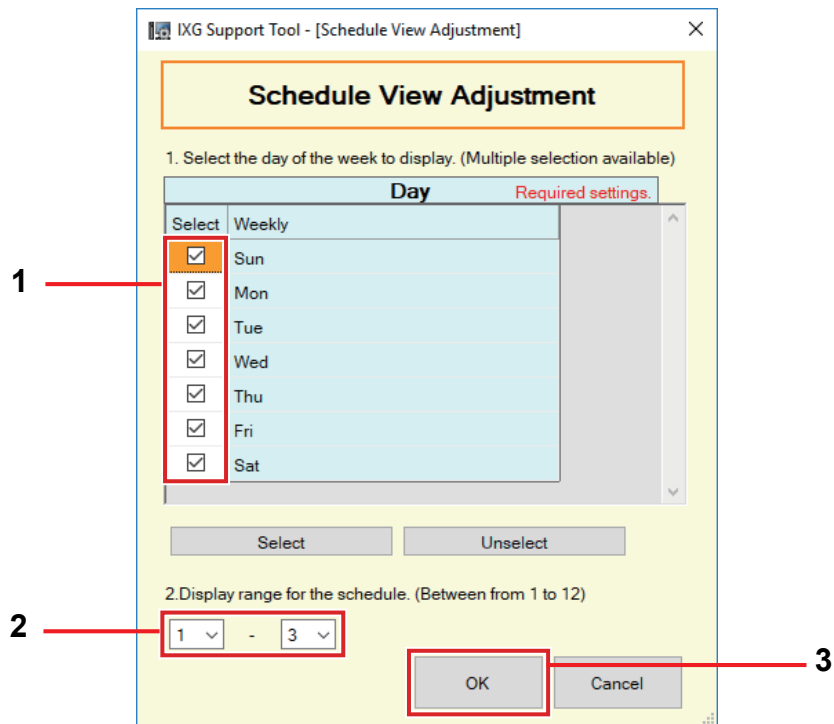

1. Select the day to display from "Day." (Multiple selections allowed.)
 - To select or unselect all days at once, click **[Select]** or **[Unselect]**.
 - By default, all days are shown.
2. Select the range of schedules to display (1 - 12) that can be configured for each day.
 - By default, the range of 1 - 3 is displayed.
3. Click **[OK]**.
 - Click **[Cancel]** to finish configuring the schedule display.

7.3.2 Daily Schedule

Configure the transfer destination and time for each individual day.

A schedule one year from the set day can be configured. 12 schedules can be set for each day.

Move row

Up to 50 station number rows can be displayed at a time. Switch the screen as follows.
[Previous]: Display the previous 50 rows.
[Next]: Display the next 50 rows.
[Apply]: Enter the station number and click **[Apply]** to move the cursor to the row of the station number that was entered.

Daily schedule

Select the date and schedule range to configure. The Settings screen is displayed.

1. Select the date from the drop down menu.
2. Select the range of schedules to display (1 - 12) that can be configured for each day.
 - By default, the range of 1 - 3 is displayed.
3. Click **[Change to Daily Schedule Display]**.

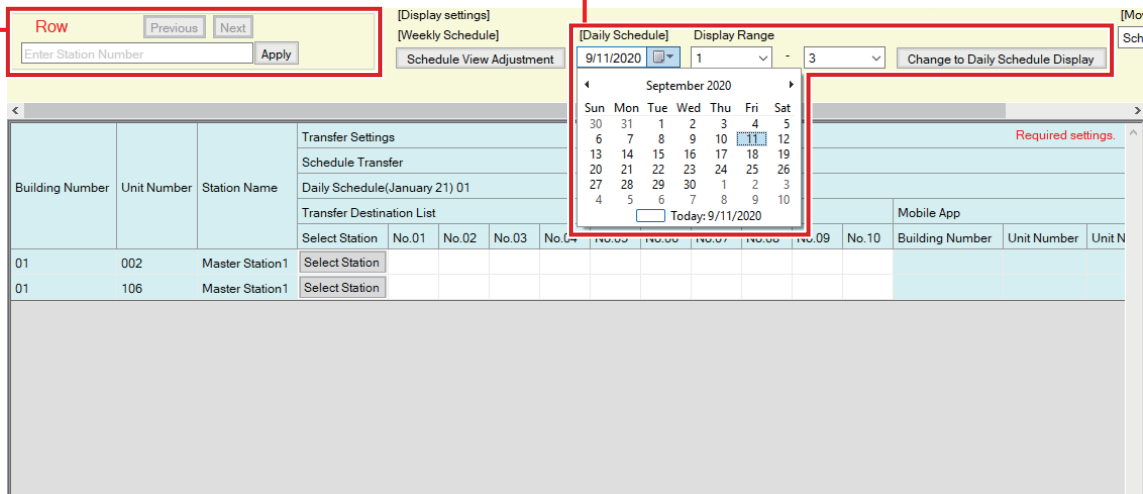

Transfer Destination List

| | |
|-----------------|--|
| Compatible type | <input type="checkbox"/> IXG-2C7(-*) <input type="checkbox"/> IXG-MK <input checked="" type="checkbox"/> IX-MV7-* <input type="checkbox"/> IXG-DM7(-*) <input type="checkbox"/> IX-DA <input type="checkbox"/> IX-BA <input type="checkbox"/> IX-DV, IX-DVF(-*) <input type="checkbox"/> IX-SSA(-*) <input type="checkbox"/> IX-EA, IX-EAU <input type="checkbox"/> IX-FA <input type="checkbox"/> IXGW-LC <input type="checkbox"/> IXGW-GW <input type="checkbox"/> Intercom App |
| Description | Configure the transfer destination station (station number) and Mobile App when performing schedule transfer. Up to 10 stations can be configured as transfer destinations for each of 12 day schedules (when registering a Mobile App, 9 stations and a single unit containing the Mobile App). However, if the call originating station is IX-DA or IX-BA, calls will only be transferred to the station entered for "No.01." To configure a station, enter the station number or click [Select Station] to select one. To configure a Mobile App, click "Mobile App" - [Select] . Select the unit containing the Mobile App to register as a transfer destination, and then click [OK] . |
| Settings | Multiple building system: 3-24 digits Single building system: 3-5 digits |

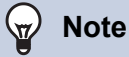
**Note**

- To register a "Mobile App," first register the "Mobile App" in "[Mobile App List \(→page 84\)](#)". A "Mobile App" registered in a "Mobile App List" can be registered as a transfer destination "Mobile App."

■ Re-Transfer Destination

| | |
|-----------------|---|
| Compatible type | <input type="checkbox"/> IXG-2C7(-*) <input type="checkbox"/> IXG-MK <input checked="" type="checkbox"/> IX-MV7-* <input type="checkbox"/> IXG-DM7(-*) <input type="checkbox"/> IX-DA <input type="checkbox"/> IX-BA <input type="checkbox"/> IX-DV, IX-DVF(-*) <input type="checkbox"/> IX-SSA(-*) <input type="checkbox"/> IX-EA, IX-EAU <input type="checkbox"/> IX-FA <input type="checkbox"/> IXGW-LC <input type="checkbox"/> IXGW-GW <input type="checkbox"/> Intercom App |
| Description | Configure the transfer destination station (station number) when performing schedule transfer again for a transferred call. Only a single station can be configured as a transfer destination for each of the 12 day schedules. However, if the call originating station is IX-DA or IX-BA, the call will arrive without being retransferred. Enter the station number or click [Select Station] to select one. To configure a Mobile App, click "Mobile App" - [Select] . Select the unit containing the Mobile App to register as a transfer destination, and then click [OK] . |
| Settings | Multiple building system: 3-24 digits Single building system: 3-5 digits |

■ Start Time

| | |
|-----------------|--|
| Compatible type | <input type="checkbox"/> IXG-2C7(-*) <input type="checkbox"/> IXG-MK <input checked="" type="checkbox"/> IX-MV7-* <input type="checkbox"/> IXG-DM7(-*) <input type="checkbox"/> IX-DA <input type="checkbox"/> IX-BA <input type="checkbox"/> IX-DV, IX-DVF(-*) <input type="checkbox"/> IX-SSA(-*) <input type="checkbox"/> IX-EA, IX-EAU <input type="checkbox"/> IX-FA <input type="checkbox"/> IXGW-LC <input type="checkbox"/> IXGW-GW <input type="checkbox"/> Intercom App |
| Description | Set the Start Time to enable schedule transfer. |
| Settings | 00:00 - 23:59 |

■ End Time

| | |
|-----------------|--|
| Compatible type | <input type="checkbox"/> IXG-2C7(-*) <input type="checkbox"/> IXG-MK <input checked="" type="checkbox"/> IX-MV7-* <input type="checkbox"/> IXG-DM7(-*) <input type="checkbox"/> IX-DA <input type="checkbox"/> IX-BA <input type="checkbox"/> IX-DV, IX-DVF(-*) <input type="checkbox"/> IX-SSA(-*) <input type="checkbox"/> IX-EA, IX-EAU <input type="checkbox"/> IX-FA <input type="checkbox"/> IXGW-LC <input type="checkbox"/> IXGW-GW <input type="checkbox"/> Intercom App |
| Description | Configure the time at which to end schedule transfer. If set earlier than "Start Time," the end time will be the time the following day. |
| Settings | 00:00 - 23:59 |

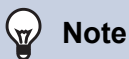
**Note**

- When configuring a Entrance Station or Door Station as a transfer destination, configure only a single Entrance Station or Door Station. If multiple stations are configured, calls will not be transferred to the Entrance Station or Door Station.



Additional Settings



1. Confirming Station Information

1.1 Confirming Station Information on the Entrance Station

Confirm the following information on the Entrance Station.

- Main: The firmware version for the main CPU
- Sub: The firmware version for the sub CPU (IXG-DM7-HID only)
- Station Number
- IP Address
- Subnet Mask
- Default Gateway
- Mac Address

1. Enter "ABAB1234" using the keypad.

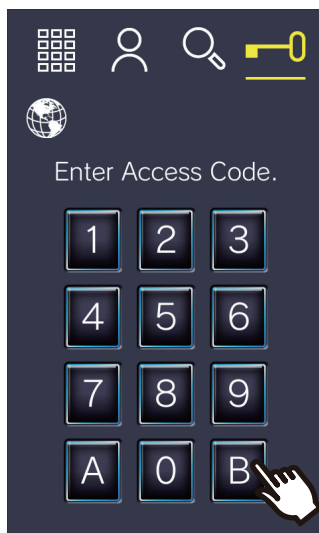

2. Confirm station information.

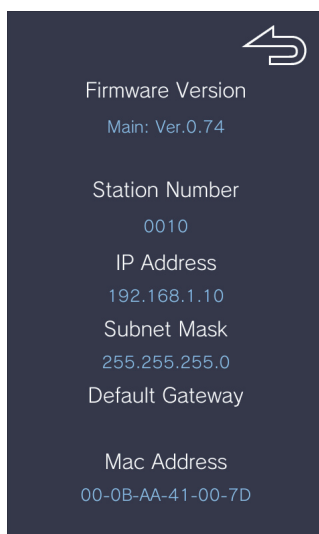

• Tap  to return to the previous screen.



Note

- If "Error" is displayed.
 - The access controller is turned off
 - The sub CPU is disconnected



<https://www.aiphone.net/>

AIPHONE CO., LTD., NAGOYA, JAPAN

Issue Date: Mar. 2020 © 0320 RQ 62286