



1645 Lemonwood Dr.  
Santa Paula, CA. 93060, USA  
Telephone: (877) 432-6627  
www.dannmar.com

# INSTALLATION AND OPERATION MANUAL

12,000/15,000LB / 5,443/6,804 KG CAPACITY  
TWO-POST LIFTS

**MODELS:**

- D2-12C
- D2-15C

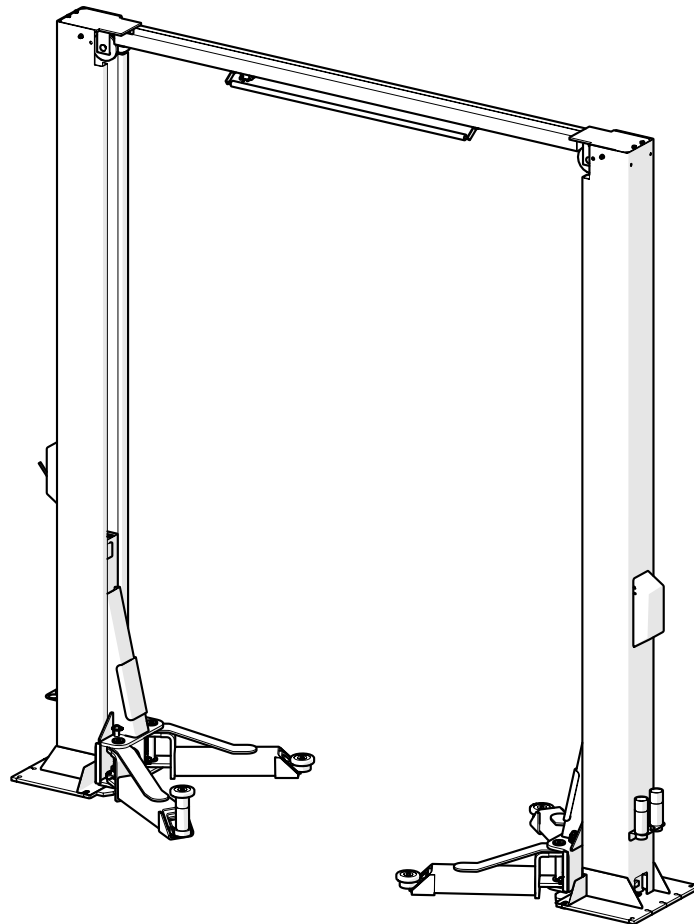

**READ FIRST**



Do not operate this machine until you read and understand all the dangers, warnings and cautions in this manual.

P/N 5900252  
Rev A - October 2020



Read the entire contents of this manual before using this product. Failure to follow the instructions and safety precautions in this manual can result in serious injury or death. Make sure all other operators also read this manual. Keep the manual near the product for future reference. ***By proceeding with setup and operation, you agree that you fully understand the contents of this manual and assume full responsibility for product use.***

# READ THIS ENTIRE MANUAL BEFORE INSTALLATION & OPERATION BEGINS.

**Unit Information.** Enter the Model Number, Serial Number, and the Date of Manufacture from the label on your unit. This information is required for part or warranty issues.

Model : \_\_\_\_\_

Serial: . \_\_\_\_\_

Date of Manufacture: \_\_\_\_\_

<b>DANNMAR</b>		Santa Paula, CA USA www.dannmar.com	
MODEL NUMBER			
DESCRIPTION			
LIFT CAPACITY		DATE CODE	
VOLTAGE		SERIAL NUMBER	
<input type="checkbox"/> 110-220V, 50-60 Hz, 1 Ph			
<input type="checkbox"/> 208-240V, 50-60 Hz, 1 Ph			
<input type="checkbox"/> 380-415V, 50-60 Hz, 3 Ph			
<input type="checkbox"/> 208-440V, 50-60 Hz, 3 Ph			
		UPC	
 <b>DANGER!</b> Disconnect Power Before Servicing		MADE IN CHINA	
WARRANTY VOID IF DATA PLATE IS REMOVED		  PH 5905703	

## PRODUCT WARRANTY

Our comprehensive product warranty means more than a commitment to you; it's also a commitment to the value of your new Dannmar lift. For full warranty details and to register your new lift contact your nearest Dannmar dealer or visit the Dannmar website.

What is not covered under this warranty:

- a. Any failure that results from Purchaser's abuse, neglect or failure to operate, maintain or service product in accordance with instructions provided in the owner's manual(s) supplied.
- b. Any damage caused by overloading lift beyond rated capacity.
- c. Items or service normally required to maintain the product, i.e. lubricants, oil, etc.
- d. Items considered general wear parts such as rubber pads, lifting cables, etc. unless wear or failure is a direct result of manufacturer defect due to material and/or workmanship.
- e. Any component damaged in shipment or any failure caused by installing or operating lift under conditions not in accordance with installation and operation guidelines or damaged by contact with tools or surroundings.
- f. Motor or pump failure caused by rain, excessive humidity, corrosive environments or other contaminants.
- g. Rusted components due to improper maintenance or corrosive environments.
- h. Cosmetic defects that do not interfere with product functionality.
- i. Damage due to incorrect voltage or improper wiring.
- j. Any incidental, indirect, or consequential loss, damage or expense that may result from any defect, failure or malfunction of BendPak Inc. product.
- k. All electrical components (excluding power unit) are guaranteed for one year against defects in workmanship and/or materials when the lift is installed and used according to specifications.

## LIMITATIONS

Every effort has been taken to ensure complete and accurate instructions have been included in this manual. However, product updates, revisions and/or changes may have occurred since this manual was published. BendPak reserves the right to change any information without incurring any obligation for equipment previously or subsequently sold. BendPak is not responsible for typographical errors.

## IMPORTANT NOTICE

Do not attempt to install this lift if you have never been trained on basic automotive lift installation procedures. Never attempt to lift components without proper lifting tools such as forklift or cranes. Stay clear of any moving parts that can fall and cause injury. These instructions must be followed to ensure proper installation and operation of your lift. Failure to comply with these instructions can result in serious bodily harm and void product warranty. Manufacturer will assume no liability for loss or damage of any kind, expressed or implied resulting from improper installation or use of this product.



**PLEASE READ ENTIRE MANUAL  
PRIOR TO INSTALLATION**

## SYMBOLS

Following are the symbols that may be used in the Manual:



Watch for this symbol: Calls attention to an immediate hazard that **will** result in injury or death.



Watch for this symbol: Calls attention to a hazard or unsafe practice that **could** result in injury or death.



Watch for this symbol: Calls attention to a hazard or unsafe practice that could result in **product** or **property damage**.

## OWNER'S RESPONSIBILITY

To maintain the lift and user safety, the responsibility of the owner is to read and follow these instructions:

- ◆ Follow all installation, operation, and maintenance instructions.
- ◆ Make sure installation conforms to all applicable Local, State, and Federal Codes, Rules, and Regulations; such as State and Federal OSHA Regulations and Electrical Codes.
- ◆ Carefully check the lift for correct initial function.
- ◆ Read and follow the safety instructions. Keep them readily available for machine operators.
- ◆ Make certain all operators are properly trained, know how to safely and correctly operate the unit, and are properly supervised.
- ◆ Allow unit operation only with all parts in place and operating safely.
- ◆ Carefully inspect the unit on a regular basis and perform all maintenance as required.
- ◆ Service and maintain the unit only with authorized or approved replacement parts.
- ◆ Keep all instructions permanently with the unit and all decals on the unit clean and visible.

## SHIPPING INFORMATION

Your equipment was carefully checked before shipping. Nevertheless, you should thoroughly inspect the shipment **before** you sign to acknowledge that you received it.

Do not sign the bill of lading until **after** you have inspected the shipment.

**NOTIFY THE CARRIER AT ONCE** if any hidden loss or damage is discovered after receipt and request the carrier to make an inspection. If the carrier will not do so, prepare a signed statement to the effect that you have notified the carrier (on a specific date) and that the carrier has failed to comply with your request.

**IT IS DIFFICULT TO COLLECT FOR LOSS OR DAMAGE AFTER YOU HAVE GIVEN THE CARRIER A CLEAR RECEIPT.** File your claim with the carrier promptly. Support your claim with copies of the bill of lading, freight bill, invoice, and photographs, if available. Our willingness to assist in helping you process your claim does not make BendPak responsible for collection of claims or replacement of lost or damaged materials.

# TABLE OF CONTENTS

Contents	Page No.
Warranty / Serial Number Information . . . . .	2
Definitions of Hazard Levels . . . . .	3
Owner's Responsibility . . . . .	3
Before You Begin . . . . .	3
Installer/Operator Agreement/ Protective Equipment . . . . .	5
Important Safety Instructions . . . . .	6
Tools Required . . . . .	7
Step 1 / Selecting Site . . . . .	7
Step 2 / Floor Requirements / Concrete Specifications . . . . .	7
Assembly View / Description of Parts . . . . .	8
Specifications . . . . .	9
Clearances . . . . .	10
Step 3 / Column Preparation . . . . .	11
Equalizer Cable Routing . . . . .	12
Hose Routing . . . . .	13
Step 4 / Site Layout . . . . .	14
Step 5 / Installing Power Side Column . . . . .	15
Step 6 / Installing Off Side Column . . . . .	15
Step 7 / Mounting The Overhead Assembly . . . . .	16
Step 8 / Mounting The Hydraulic Power Unit . . . . .	16
Step 9 / Installing the Safeties and Safety Cable . . . . .	17
Step 10 / Installing Hydraulic Hoses . . . . .	10
Step 11 / Routing the Equalizer Cables . . . . .	19
Step 12 / Installing Overhead Microswitch . . . . .	20
Step 13 / Installing Power Unit Hose Assembly and Power Side Safety Cover . . . . .	21
Step 14 / Installing the Lift Arms . . . . .	22
Carriage Stop Bolt Installation Warning. . . . .	24
Step 15 / Power Unit Connection . . . . .	27
Step 16 / Final Adjustments . . . . .	27
Post Installation Checklist . . . . .	28
Step 17 / Lubrication. . . . .	28
Step 18 / Bleeding the Cylinders . . . . .	28
Step 19 / Operation/ Maintenance . . . . .	29
Troubleshooting . . . . .	38
Labels. . . . .	39
Parts Drawings . . . . .	42

**INSTALLER / OPERATOR  
PLEASE READ AND FULLY UNDERSTAND.  
BY PROCEEDING YOU AGREE TO THE  
FOLLOWING:**

- ◆ I have visually inspected the site where the lift is to be installed and verified the concrete to be in good condition and free of cracks or other defects. I understand that installing a lift on cracked or defective concrete could cause lift failure resulting in personal injury or death.
- ◆ I understand that a level floor is required for proper installation and level lifting.
- ◆ I understand that I am responsible if my floor is of questionable slope and that I will be responsible for all charges related to pouring a new level concrete slab if required and any charges.
- ◆ I understand that Danmar lifts are supplied with concrete fasteners meeting the criteria of the latest version of the American National Standard “Automotive Lifts - Safety Requirements for Construction, Testing, and Validation” ANSI/ALI ALCTV and that I will be responsible for all charges related to any special regional structural and/or seismic anchoring requirements specified by any other agencies and/or codes such as the Uniform Building Code (UBC) and/or International Building Code (IBC).
- ◆ I assume full responsibility for the concrete floor and condition thereof, now or later, where the above equipment model(s) are to be installed. Failure to follow warning symbols may lead to serious personal injury or death to operator or bystander or damage to property.
- ◆ I understand that Danmar lifts are designed to be installed in indoor locations only. Failure to follow installation instructions may lead to serious personal injury or death to operator or bystander or damage to property or lift.



Failure to follow danger, warning, and caution instructions may lead to serious personal injury or death to operator or bystander or damage to property.



Please read entire manual prior to installation. Do not operate this machine until you read and understand all the dangers, warnings and cautions in this manual. For additional copies or further information, contact:

**BendPak Inc. / Danmar Products**

1645 Lemonwood Dr.  
Santa Paula, CA. 93060  
(877) 432-6627  
www.danmar.com

**INSTALLER / OPERATOR  
PROTECTIVE EQUIPMENT**



You **MUST** wear OSHA-approved (publication 3151) Personal Protective Equipment **at all times** when installing the Lift. Leather gloves, steel-toed work boots, eye protection, back belts, and hearing protection **are mandatory**.



**THIS SYMBOL POINTS OUT IMPORTANT SAFETY INSTRUCTIONS WHICH IF NOT FOLLOWED COULD ENDANGER THE PERSONAL SAFETY AND/OR PROPERTY OR YOURSELF AND OTHERS AND CAN CAUSE PERSONAL INJURY OR DEATH. READ AND FOLLOW ALL INSTRUCTIONS IN THIS MANUAL BEFORE ATTEMPTING TO OPERATE THIS EQUIPMENT.**

## IMPORTANT SAFETY INSTRUCTIONS

*Read these safety instructions entirely.*

Refer to ANSI/ALI ALIS Standard (R2015) *Safety Requirements for Installation and Service of Automotive Lifts* for more information about safely installing your Lift.

- Read and understand all instructions and all safety warnings before operating the lift.
  - Do **NOT** touch hot parts; you could be burned. Always use care with the equipment.
  - Do **NOT** operate equipment with a damaged cord or if the equipment has been dropped or damaged – until it has been examined by a qualified service person.
  - Do **NOT** let a cord hang over the edge of the table, bench, or counter or come in contact with hot manifolds or moving fan blades.
  - If an extension cord is necessary, a cord with a current rating equal to or more than that of the equipment should be used. Cords rated for less current than the equipment may overheat..
  - Always unplug equipment from electrical outlet when not in use. Never use the cord to pull the plug from the outlet. Grasp plug and pull to disconnect.
  - Let equipment cool completely before putting away. Loop cord loosely around equipment when storing.
  - To reduce the risk of fire, do **NOT** operate equipment near open containers of flammable liquids (gasoline).
  - Adequate ventilation should be provided when working on operating internal combustion engines.
  - Keep hair, loose clothing, fingers, and all parts of body away from moving parts.
  - To reduce the risk of electric shock, do **NOT** use on wet surfaces or expose to rain. Disconnect power at the receptacle or at the circuit breaker switch before performing any electrical maintenance. Secure the plug so that it cannot be accidentally
- **ALWAYS WEAR SAFETY GLASSES.** Everyday eyeglasses only have impact resistant lenses, they are not safety glasses.
  - Guard against electric shock. This lift must be grounded while in use to protect operator from electric shock. Never connect the green power cord wire to a live terminal. This is for ground only.
  - Only trained operators should operate this lift. All non-trained personnel should be kept away from the work area. Never let non-trained personnel come in contact with, or operate lift.
  - DO **NOT** override self-closing lift controls.
  - Clear area if vehicle is in danger of falling.
  - ALWAYS make sure the safeties are engaged before attempting to work on or near a vehicle.
  - **WARNING! RISK OF EXPLOSION.** This equipment has internal arcing or sparking parts which should not be exposed to flammable vapors. This machine should not be located in a recessed area or below floor level.
  - **MAINTAIN WITH CARE.** Keep lift clean for better and safer performance. Follow manual for proper lubrication and maintenance instructions. Keep control handles and/or buttons dry, clean and free from grease and oil.
  - Check for damaged parts. Check for alignment of moving parts, breakage of parts or any condition that may affect operation of lift. Do **NOT** use lift if any component is broken or damaged.
  - NEVER remove safety related components from the lift. Do **NOT** use lift if safety related components are missing or damaged.
  - **STAY ALERT.** Use common sense and watch what you are doing. Remember, **SAFETY FIRST.**



## TOOLS REQUIRED

- ◆ Rotary Hammer Drill or Similar
- ◆ 3/4" Masonry Bit
- ◆ Hammer
- ◆ 4 Foot Level
- ◆ Open-End Wrench Set: SAE/Metric
- ◆ Socket And Ratchet Set: SAE/Metric
- ◆ Hex-Key / Allen Wrench Set
- ◆ Large Crescent Wrench
- ◆ Large Pipe Wrench
- ◆ Crow Bar
- ◆ Chalk Line
- ◆ Medium Flat Screwdriver
- ◆ Tape Measure: 25 Foot Minimum
- ◆ Needle Nose Pliers

## IMPORTANT NOTICE

These instructions must be followed to ensure proper installation and operation of your lift. Failure to comply with these instructions can result in serious bodily harm and void product warranty. Manufacturer will assume no liability for loss or damage of any kind, expressed or implied resulting from improper installation or use of this product.

### STEP 1

#### (Selecting a Site)

Before installing your new lift, check the following.

1. **LIFT LOCATION:** Always use architects plans when available. Check layout dimension against floor plan requirements making sure that adequate space if available.
2. **OVERHEAD OBSTRUCTIONS:** The area where the lift will be located should be free of overhead obstructions such as heaters, building supports, electrical lines etc.
3. **DEFECTIVE FLOOR:** Visually inspect the site where the lift is to be installed and check for cracked or defective concrete.



4. **OPERATING TEMPERATURE.** Operate lift only between temperatures of 41° -104° F.
5. Lift is designed for **INDOOR INSTALLATION ONLY.**

### STEP 2

#### (Floor Requirements)

This lift must be installed on a solid level concrete floor with no more than 3-degrees of slope. Failure to do so could cause personal injury or death.



- ◆ **DO NOT** install or use this lift on any asphalt surface or any surface other than concrete.
- ◆ **DO NOT** install or use this lift on expansion seams or on cracked or defective concrete.
- ◆ **DO NOT** install or use this lift on a second / elevated floor without first consulting building architect.

### CONCRETE SPECIFICATIONS

LIFT MODEL	CONCRETE REQUIREMENTS
12,000 Lb Models:	6.5" Min. Thickness 3,000 PSI
15,000 Lb Models:	8" Min. Thickness 3,000 PSI



All models **MUST** be installed on 3,000 PSI concrete only, conforming to the minimum requirements shown above. New concrete must be adequately cured for at least 28 days minimum.

### IMPORTANT NOTE:

Dannmar lifts are supplied with installation instructions and concrete fasteners meeting the criteria as prescribed by the American National Standard "Automotive Lifts - Safety Requirements for Construction, Testing, and Validation" ANSI/ALI LCTV. Lift buyers should contact qualified persons regarding any special regional structural and/or seismic anchoring requirements specified by any other agencies and/or codes such as the Uniform Building Code (UBC) and/or International Building Code (IBC).

**! DANGER**

**When removing the lift from shipping angles, pay close attention as the posts can slide and can cause injury. Prior to removing the bolts, make sure the posts are held securely by a Forklift or other heavy lifting device.**

**COMPONENTS**  
Make sure to take a complete inventory of parts prior to beginning installation.

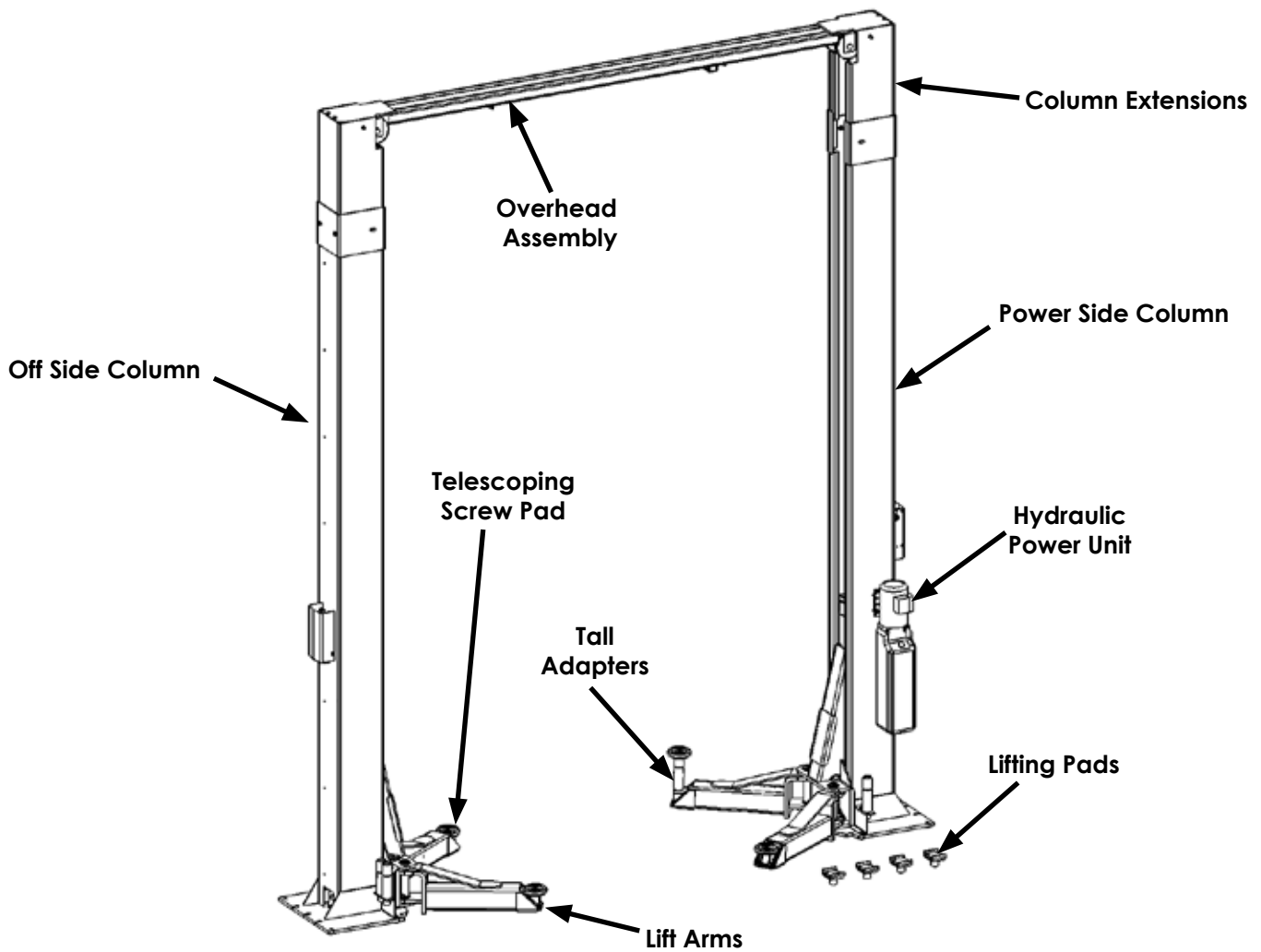



# SPECIFICATIONS

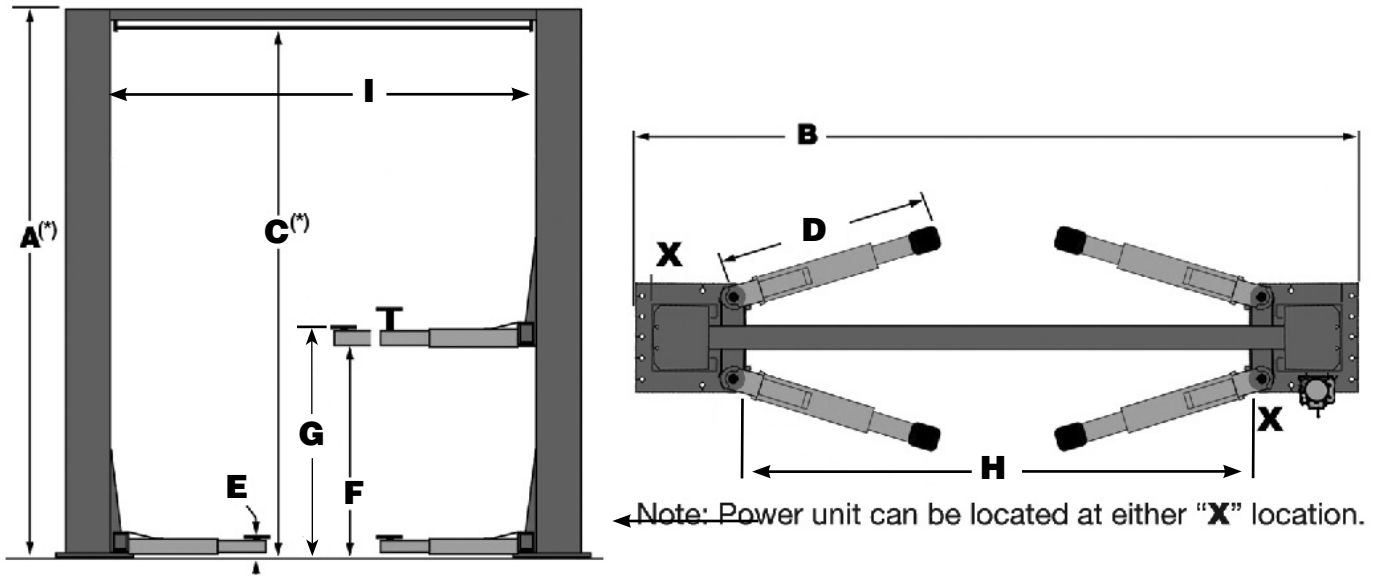

MODEL	D2-12C	D2-15C
Lifting Capacity	12,000Lbs. / 5,443 Kg.	15,000Lbs. / 6,804 Kg.
Max Capacity/ Front Axle	6,000 lbs. / 2,722 Kg.	7,500 lbs. / 3,408 Kg.
Max Capacity/ Rear Axle	6,000 lbs. / 2,722 Kg.	7,500 lbs. / 3,408 Kg.
A- Height Overall:	168" / 4,285 mm. (*)	168" / 4,285 mm.
B -Width Overall	155.25" / 3,941 mm.	155.25" / 3,941 mm.
C- Floor to Overhead Switch:	162.75" / 4,131 mm. (*)	162.75" / 4,131 mm.
D- Arm Reach	31.5" (800 mm) - 58" (1,473 mm)	37.25" (946 mm) - 58" (1,473 mm)
E- Min. Pad Height:	4.25" / 108 mm.	6.5" / 165 mm.
F- Rise:	69" / 1,753 mm.	69" / 1,753 mm.
G - Max Lifting Height:	80" / 2,032 mm	83" / 2,108 mm
I - Width inside Columns:	119.5" / 3,035 mm	119.5" / 3,035 mm
H- Drive-Thru Clearance:	105" / 2,663 mm.	105" / 2,663 mm.
Standard Motor(**)	220 VAC / 60Hz.1Ph.	220 VAC / 60Hz.1Ph.
Time of Full Rise:	55 Seconds	55 Seconds
Max Load Per Arm:	3,000 Lbs." / 1,361 Kg.	3,750 Lbs." / 1,701 Kg.
Emission sound pressure at Operator Position < 70 dB(A)		
* An optional bolt-on top extension for column raises the overhead bar an additional 24". Must be ordered from factory at time of order.		
** For CE compliant countries see errata sheet included with control panel.		
Specifications are subject to change without notice.		

## CLEARANCES D2-12C AND D2-15C

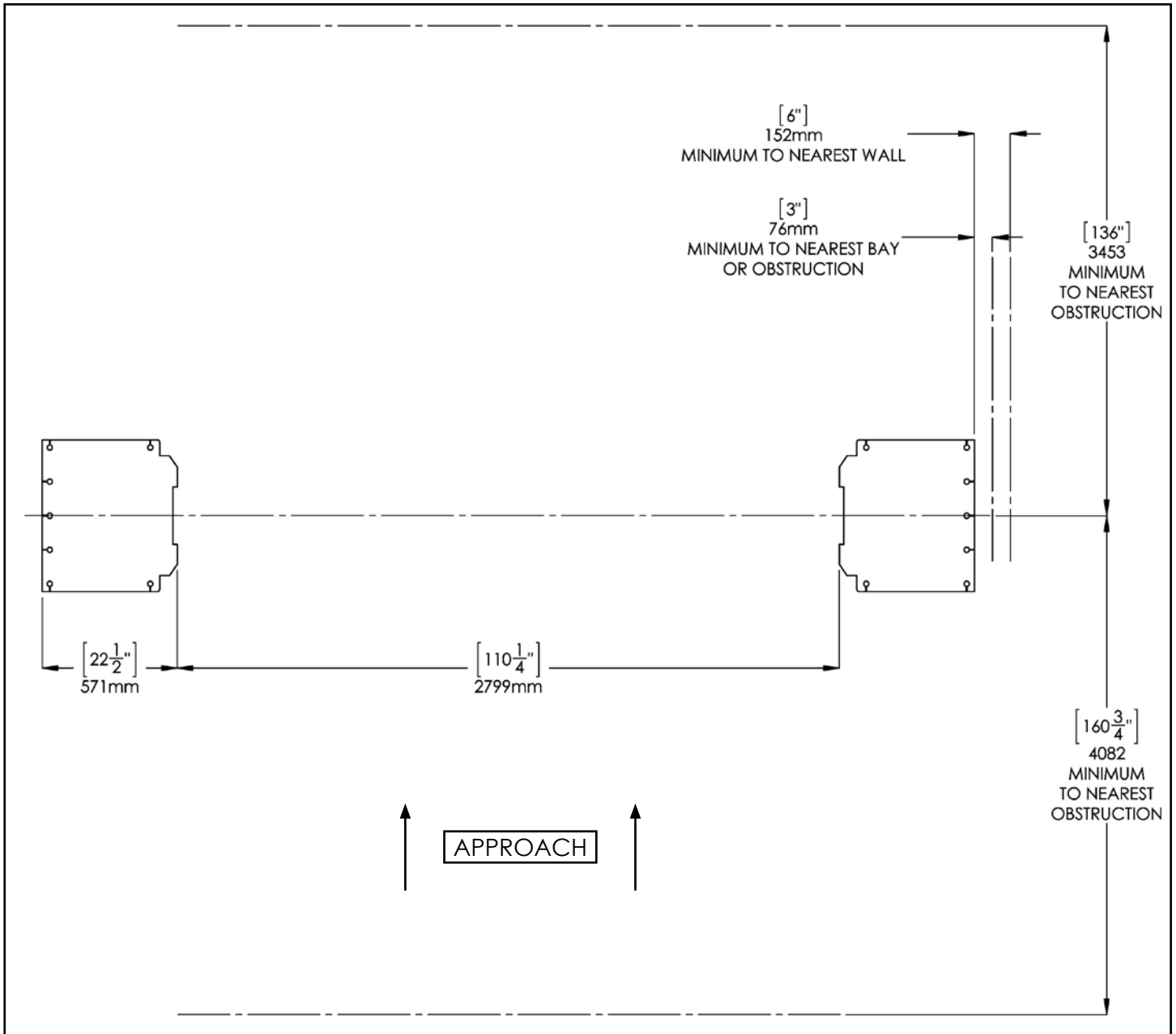

LIFT HEIGHT CLEARANCE NOTE: There must be a 1" MIN distance from top of lift to nearest obstruction.

**STEP 3**  
**(Column Preparation)**  
**COMPLETE THE FOLLOWING**  
**PRIOR TO STANDING UP COLUMNS.**

1. Slide Lift Head up Column to access the Cable Sheave and Equalizer Cable routing. (See Fig 3.1)

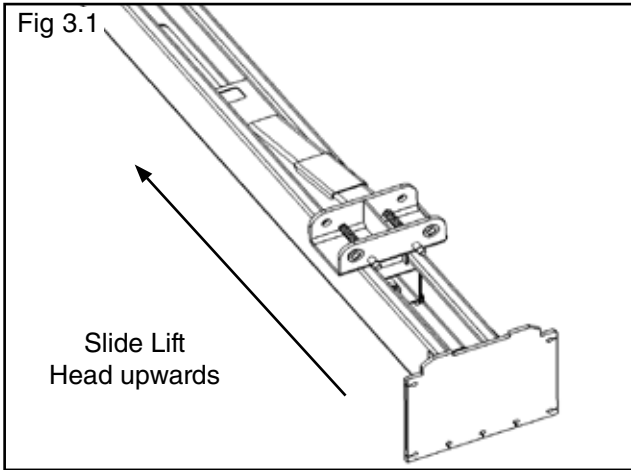

2. Temporarily remove the Cable Sheaves located at the inside bottom of each Column. (Fig. 3.2)

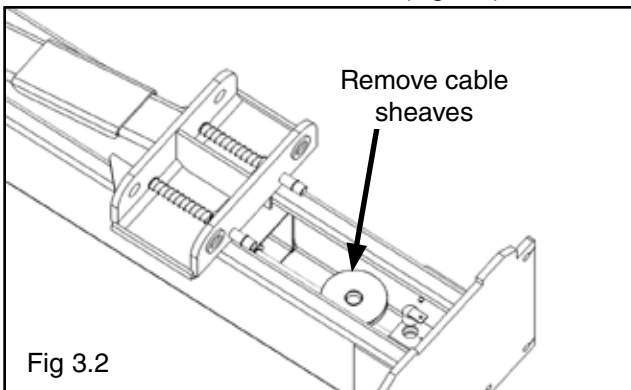

3. Route the Button End of Cable around the Bottom Sheave and secure at the carriage lock plate inside each Lift Head. Route the Threaded End of Cable up through the bottom of the carriage. Leave extra cable resting on top of carriage until further steps are required. (See Fig 3.3 and 3.4)

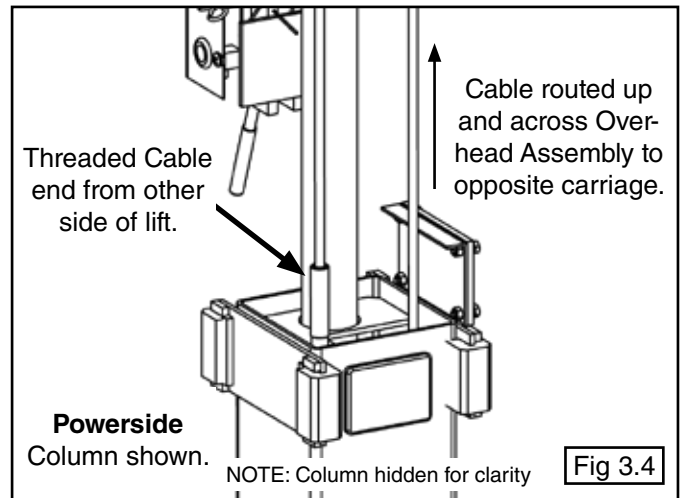
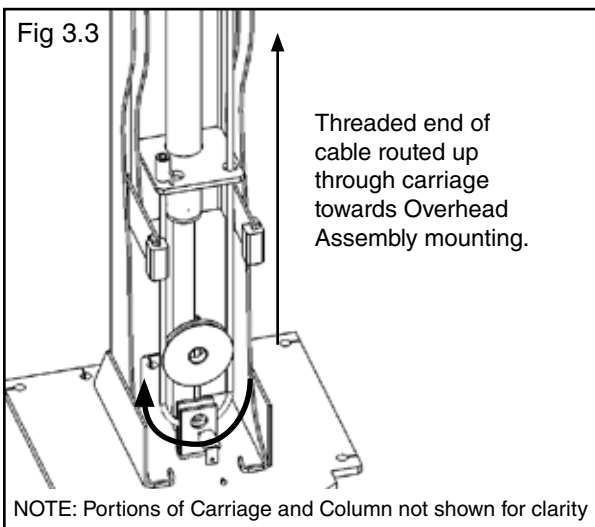

4. Install the Straight and Elbow Cylinder Fittings in Cylinder Ports. Make sure the Elbow Fittings point towards the side of the Column that the hose retainer clips are located on. (See Fig 3.5)

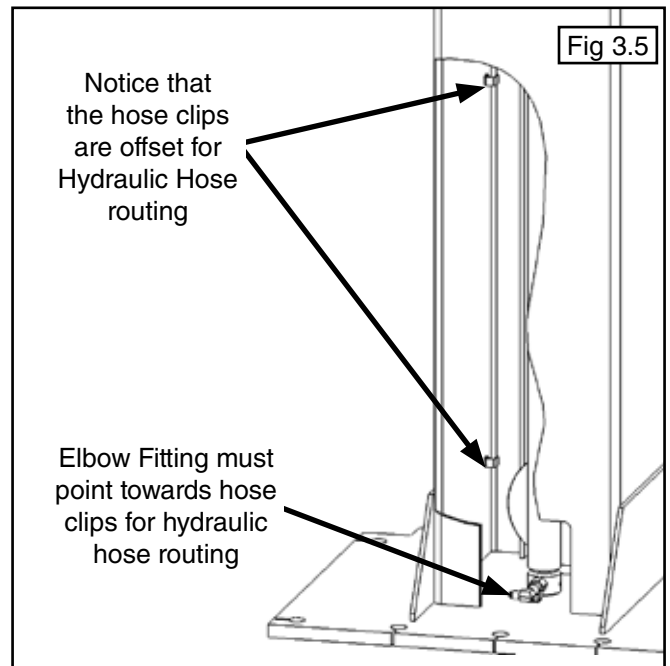

**NOTE**  
**FIT EXTENSION WELDMENTS TO POST ASSEMBLY**  
**IN THIS STEP FOR EASE OF INSTALLATION**  
**AND BOLT TOGETHER AS SHOWN ON PAGE 13**  
**WITH M10 HARDWARE.**

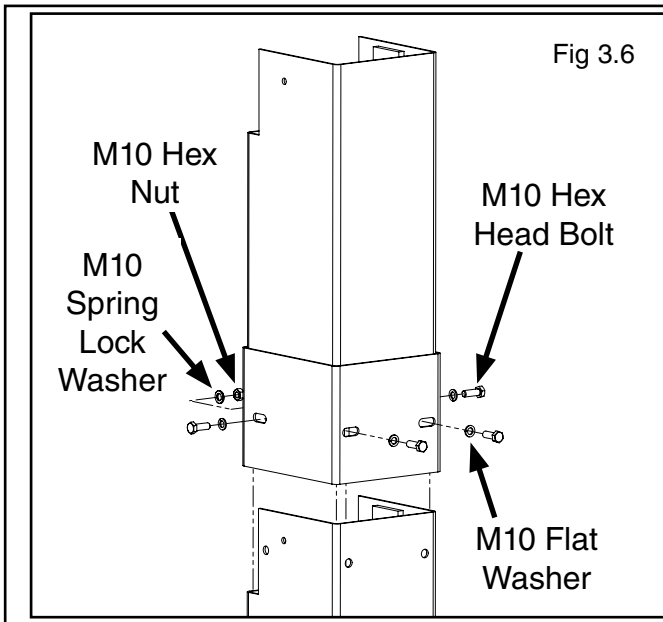

6. Route both Hoses in their respective Columns **PRIOR** to standing up the Columns. When routing the Hydraulic Hose through the Columns, make sure to route through the Retaining Clips welded inside each Column. Make sure that the Hose is clear of any moving parts. It may be necessary to tie Hose clear of obstructions by using nylon tie straps or wire. Refer to Step 10.



**BE SURE TO ROUTE THE HYDRAULIC HOSES THROUGH THE RETAINING CLIPS WELDED INSIDE EACH COLUMN.**

## EQUALIZER CABLE ROUTING

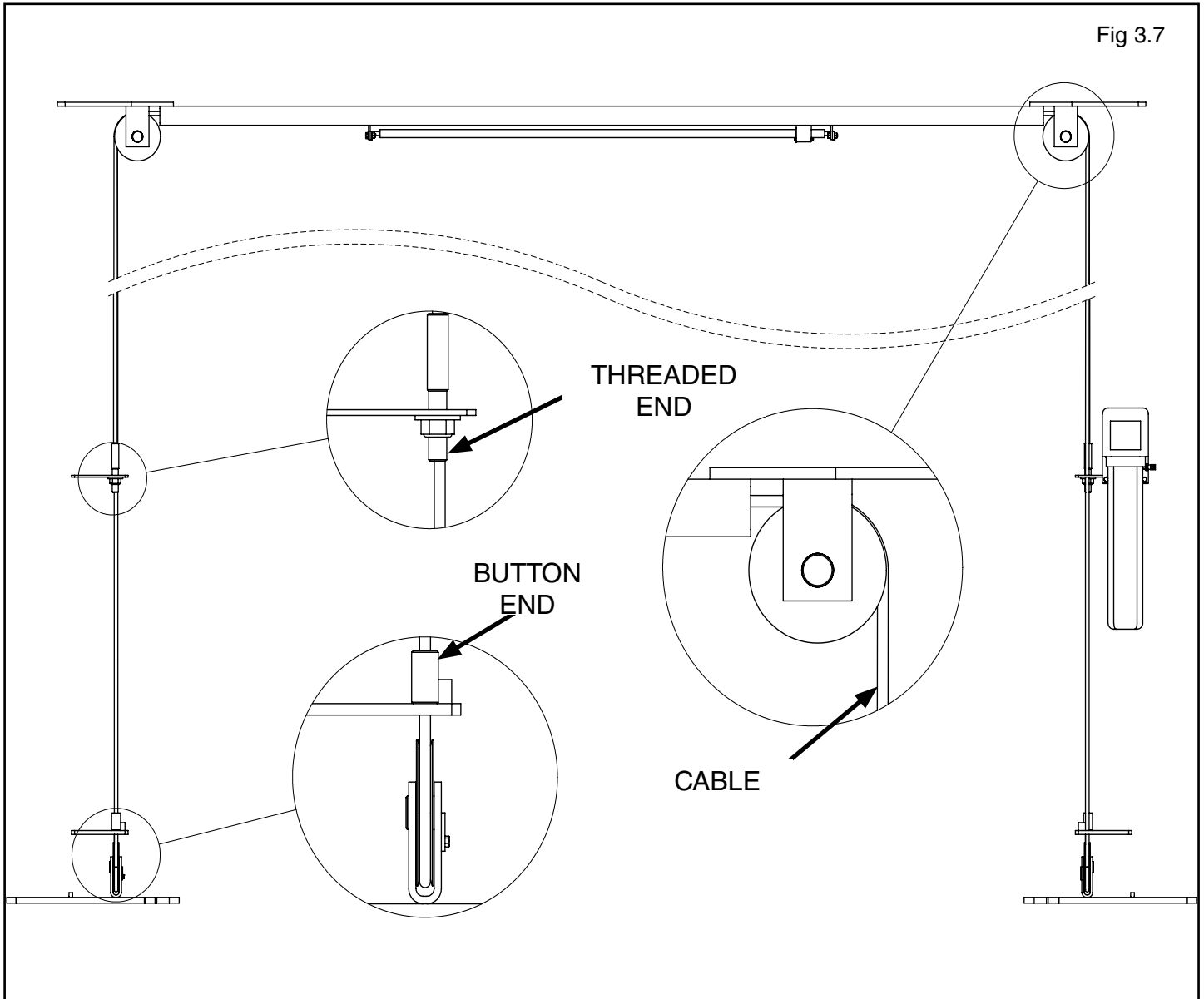

# HOSE ROUTING

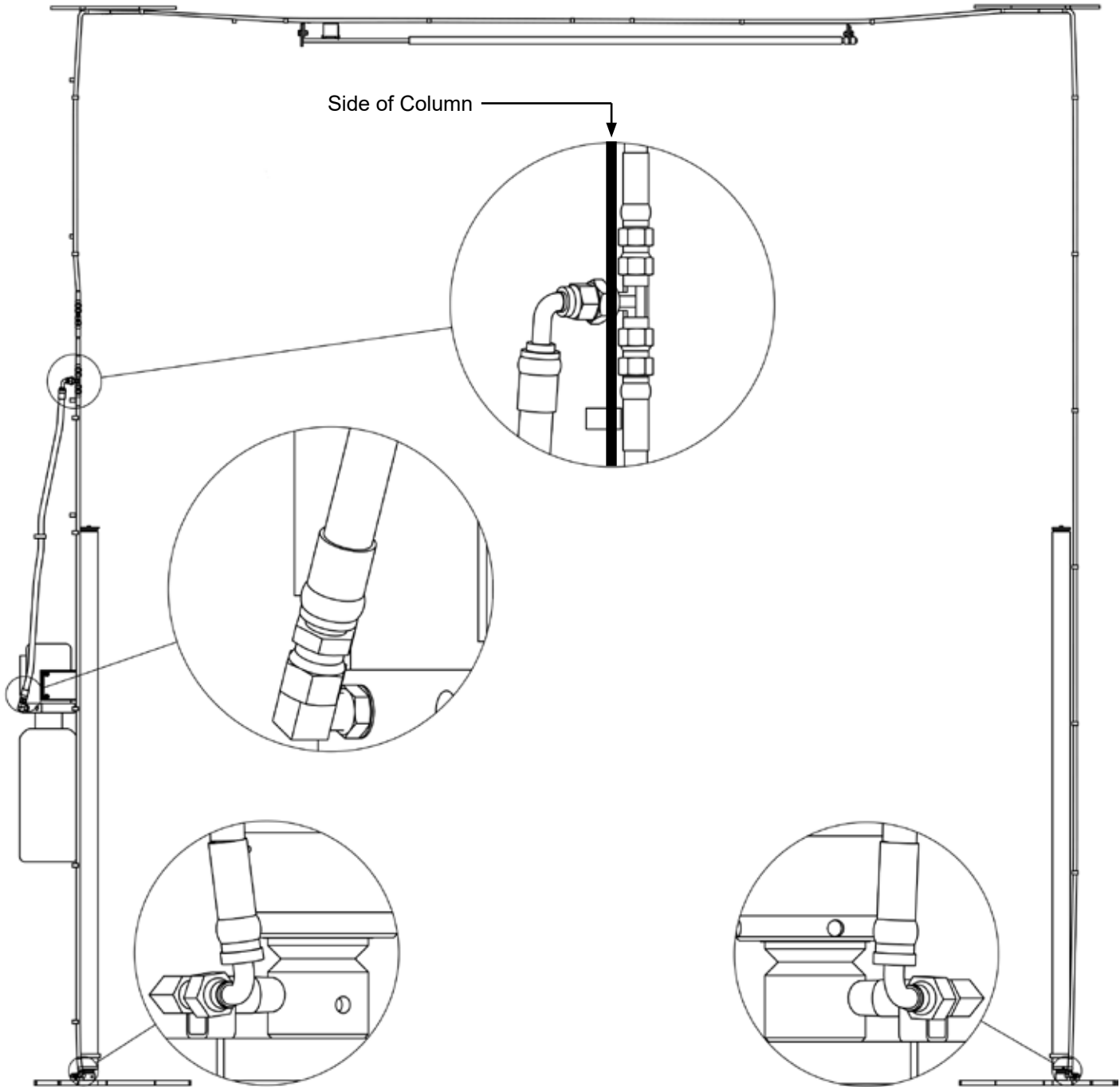

## FLOOR PLAN

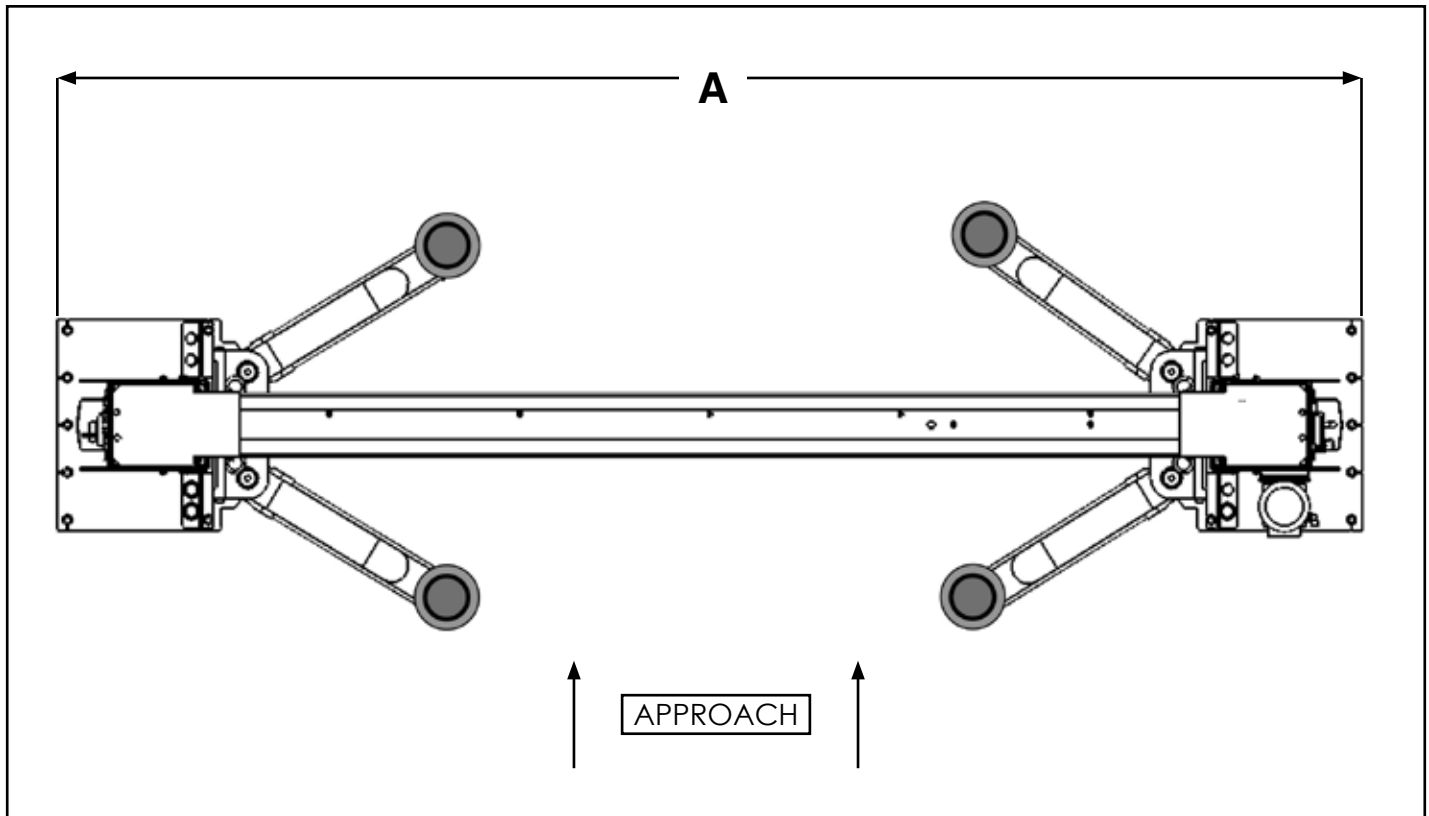

Model	A	Capacity
D2-12C	155.25" / 3,941 mm	12,000 lbs
D2-15C	155.25" / 3,941 mm	15,000 lbs

### STEP 4 (Site Layout)

1. Determine which side of the Lift will be the approach side.
2. Determine where the Power Unit will be located. The Powerside Post has the Power Unit Mounting Bracket attached to the side.
3. Determine which lift width layout you would like to use.
4. Once a location is determined, use chalk line to layout an alignment line for the Post locations. Keep all dimensions square within 1/8" (3 mm) or malfunctioning of the lift can occur. (See Fig 4.1)
5. After the Post locations are properly marked, make an outline of the posts on the floor at each Column location using the Column base plates as a template.
6. **VERIFY ALL DIMENSIONS** and make sure that the layout is perfectly square.



## STEP 5

### (Installing The POWERSIDE Column)

#### NOTE:

DANNMAR LIFTS ARE SUPPLIED WITH INSTALLATION INSTRUCTIONS AND CONCRETE FASTENERS MEETING THE CRITERIA AS PRESCRIBED BY THE LATEST VERAMERICAN NATIONAL STANDARD "AUTOMOTIVE LIFTS - SAFETY REQUIREMENTS FOR CONSTRUCTION, TESTING, AND VALIDATION" ANSI/ALI ALCTV-2011. LIFT BUYERS SHOULD CONTACT QUALIFIED PERSONS REGARDING ANY SPECIAL REGIONAL, STRUCTURAL AND/OR SEISMIC ANCHORING REQUIREMENTS SPECIFIED BY ANY OTHER AGENCIES AND/OR CODES SUCH AS THE UNIFORM BUILDING CODE (UBC) AND/OR INTERNATIONAL BUILDING CODE (IBC).

1. Before proceeding, review your measurements and ensure that the Column Base Plates are aligned with the chalk line.
2. Using the Base Plate on the POWERSIDE column as a guide, drill each anchor hole in the concrete approximately **6" deep** using a rotary hammer drill and 3/4" concrete drill-bit. Do **not** ream the hole or allow the drill to wobble.
3. After drilling, remove dust thoroughly from each hole making certain that the Column remains aligned with the chalk line.
4. Assemble the Washers and Nuts on the anchors then tap into each hole with a hammer until the washer rests against the Base Plate. Be sure that if shimming is required that enough threads are left exposed. (See Fig. 5.2)

Fig 5.2

Tap anchor bolts into each hole with a hammer until the washer rests against the baseplate.



5. Insert the shims as necessary under the Base Plate so that when the anchor bolts are tightened, the Columns will be plumb. (See Fig. 5.3)

6. With the shims and anchor bolts in place, tighten by securing the nut to the base then turning 3-5 full turns clockwise. **DO NOT** use an impact wrench for this procedure. (See Fig. 5.4)

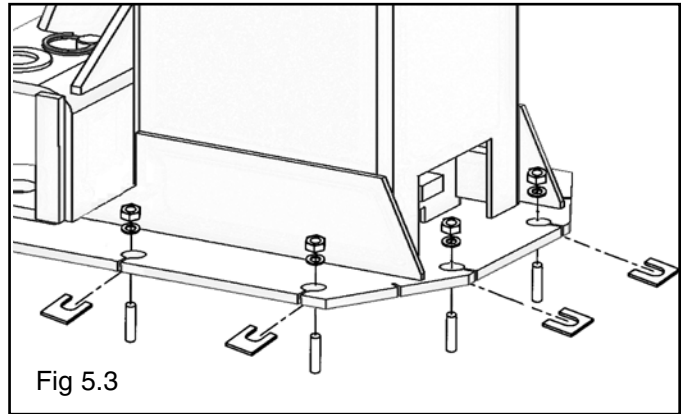

Fig 5.3

#### NOTE:

TO EASE INSTALLATION OF THE OVERHEAD ASSEMBLY, IT HELPS TO KEEP THE ANCHOR BOLTS LOOSE ON ONE OF THE POSTS UNTIL THE OVERHEAD ASSEMBLY IS MOUNTED.

## STEP 6

### (Mounting The OFFSIDE Column)

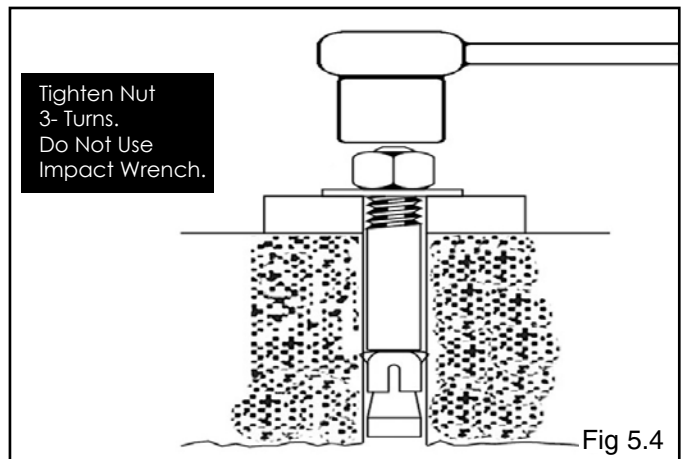

Fig 5.4

1. Position the OFFSIDE Column at the chalk line location and secure to the floor following the same instructions as outlined in the previous procedure (Steps 1-6).

#### NOTE:

TO EASE THE INSTALLATION OF THE OVERHEAD ASSEMBLY, IT HELPS TO KEEP THE ANCHOR BOLTS LOOSE ON ONE OF THE POSTS UNTIL THE OVERHEAD ASSEMBLY IS MOUNTED.

**NOTE:**  
REMOVE THE CABLE SHEAVES PRIOR TO  
EQUALIZER CABLE ROUTING.

**STEP 7**  
**(Mounting the Overhead Assembly)**

1. Remove all of the Sheaves in preparation of installing the Overhead Assembly.
2. Using a ForkLift or other lifting device, raise the Overhead Assembly into position on top of the Columns. Bolt to the columns using the 10 mm Hex Bolts, Nuts and Washers.
3. **YOU MUST POSITION THE SWITCH ENCLOSURE ADJACENT POWERSIDE COLUMN.** (See Fig. 7.1)

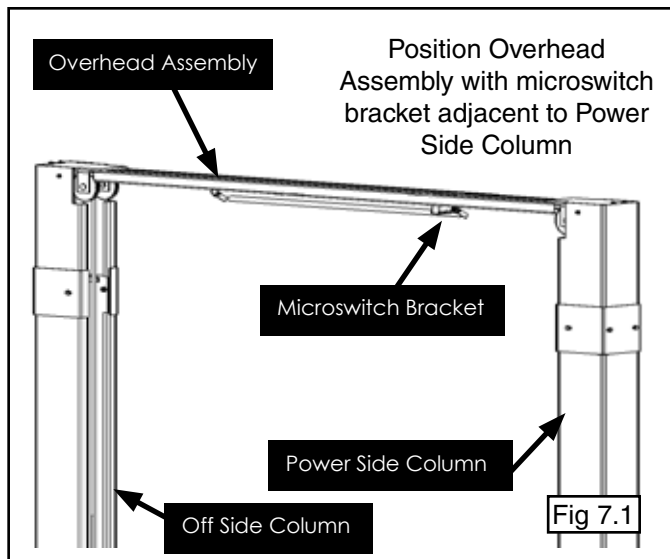

4. Tighten the Overhead Assembly Bolts.



IF THE ANCHOR BOLTS WERE LOOSENEED TO AID ON THE INSTALLATION OF THE TOP TROUGH, TIGHTEN ANCHOR BOLTS AS INDICATED IN STEP 5 ITEMS 4 - 7.

**STEP 8**  
**(Mounting the Hydraulic Power Unit)**

1. Attach the power unit to the POWER SIDE Column. Install the vibration dampener between the power unit and the power unit mounting plate on the Power Side Column, using four M8 hex head bolts and nuts supplied. (See Fig 8.1)

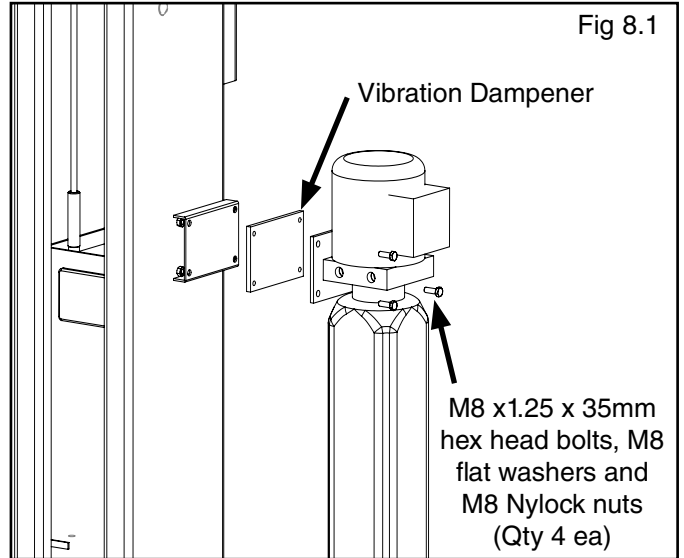

2. **Fill the reservoir with 10 WT. HYDRAULIC OIL OR DEXRON ATF**, approximately four gallons. Make sure the funnel used to fill the Power Unit and unit is clean. Do not connect power unit hydraulic hose assembly at this time.

3. The standard power unit for your lift is 220 VAC, 60HZ, 1PH. **All wiring must be performed by a licensed, certified electrician only.** SEE WIRING INSTRUCTIONS ATTACHED TO MOTOR FOR PROPER WIRING INSTRUCTIONS.



ALL WIRING MUST BE PERFORMED BY A LICENSED ELECTRICIAN.



DO NOT PERFORM ANY MAINTENANCE OR INSTALLATION OF ANY COMPONENTS WITHOUT FIRST ENSURING THAT ELECTRICAL POWER HAS BEEN DISCONNECTED AT THE SOURCE OR PANEL AND CANNOT BE RE-ENERGIZED UNTIL ALL MAINTENANCE AND/OR INSTALLATION PROCEDURES ARE COMPLETED.



**⚠ WARNING**

DO NOT RUN POWER UNIT WITHOUT OIL. DAMAGE TO POWER UNIT PUMP CAN OCCUR. THE POWER UNIT MUST BE KEPT DRY. DAMAGE TO POWER UNIT CAUSED BY WATER OR OTHER LIQUIDS SUCH AS DETERGENTS, ACID ETC., IS NOT COVERED UNDER WARRANTY. OPERATE LIFT ONLY BETWEEN TEMPERATURES OF 41 °- 104° F.

ANY IMPROPER ELECTRICAL INSTALLATION MAY DAMAGE POWER UNIT MOTOR AND RESULTING DAMAGE WILL NOT BE COVERED UNDER WARRANTY. MOTOR CAN NOT RUN ON 50HZ WITHOUT A PHYSICAL CHANGE IN MOTOR. USE A SEPARATE CIRCUIT BREAKER FOR EACH POWER UNIT. PROTECT EACH CIRCUIT WITH TIME DELAY FUSE OR CIRCUIT BREAKER.

FOR 208-230 VOLT, SINGLE PHASE, USE A 25 AMP FUSE.  
 FOR 208-230 VOLT, THREE PHASE, USE A 20 AMP FUSE.  
 FOR 380-440 VOLT, THREE PHASE, USE A 15 AMP FUSE.

**STEP 9**  
 (Installing the Safeties and Safety Cable)

1. Install safety weldments on to each respective Column. (See Figs 9.1 - 9.2)

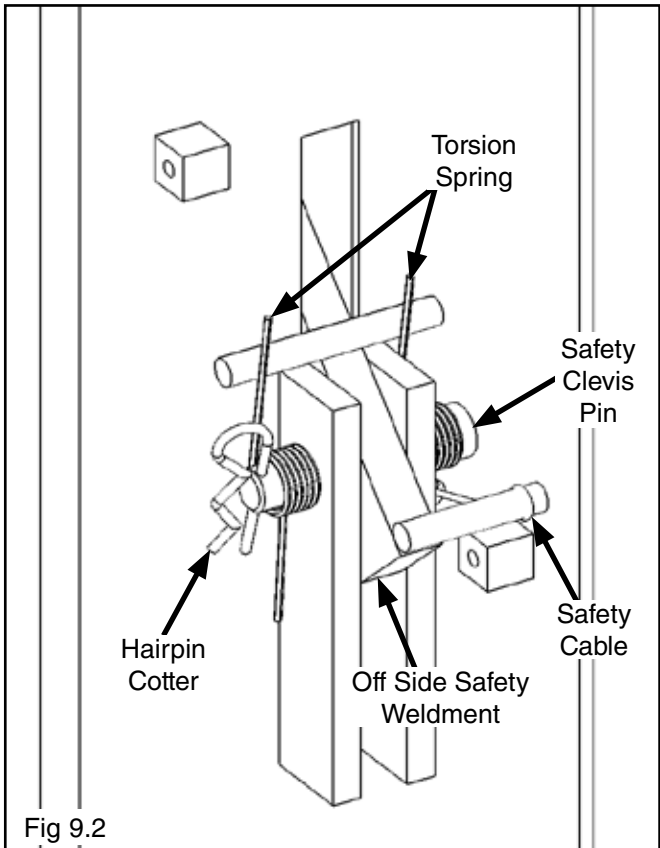
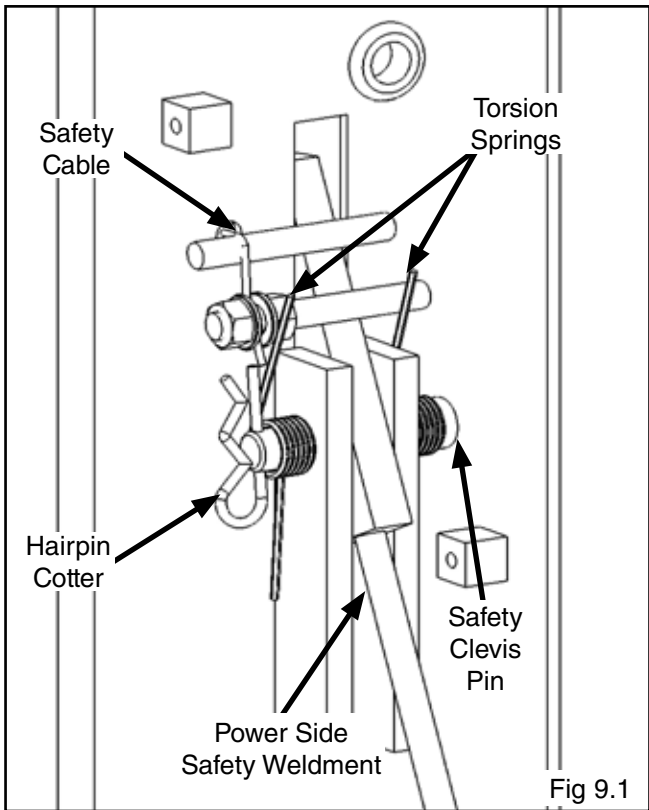

Fig 9.2

2. From the Off Side Column insert the non-looped end of the safety cable through the hole located to the right of the Off Side safety weldment. (See Fig 9.3)
3. Route the cable under the sheave and route it towards the Overhead Assembly. (See Fig 9.4)
4. Route the cable through the Overhead Assembly's safety sheave(s) and across the lift. (See Figs 9.5 - 9.6)

5. Route the cable the same way on the Power Side going back down the Column.
6. Route the cable over the top pin on the safety handle. Insert the cable end through the hole on the threaded pin. (See Fig 9.7)
7. Pull the slack out the safety cable and keep tension on the cable as nuts are being tightened. Tighten jam nuts on either side of the cable keeping the cable centered to the hole to secure it into place. (See Fig 9.7)

**! DANGER**

**ENSURE THAT BOTH THE POWER SIDE & OFF SIDE SAFETIES ENGAGE PROPERLY PRIOR TO LIFT OPERATION.**

**NOTE:**  
**MAKE SURE TO KEEP THE SAFETY CABLE CENTERED WHEN TIGHTENING JAM NUTS ON SAFETY.**

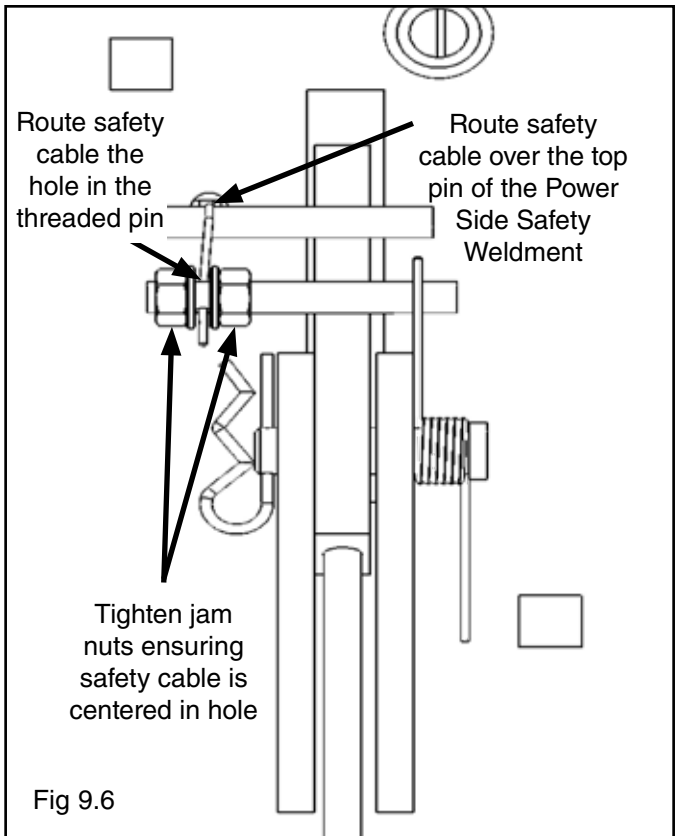
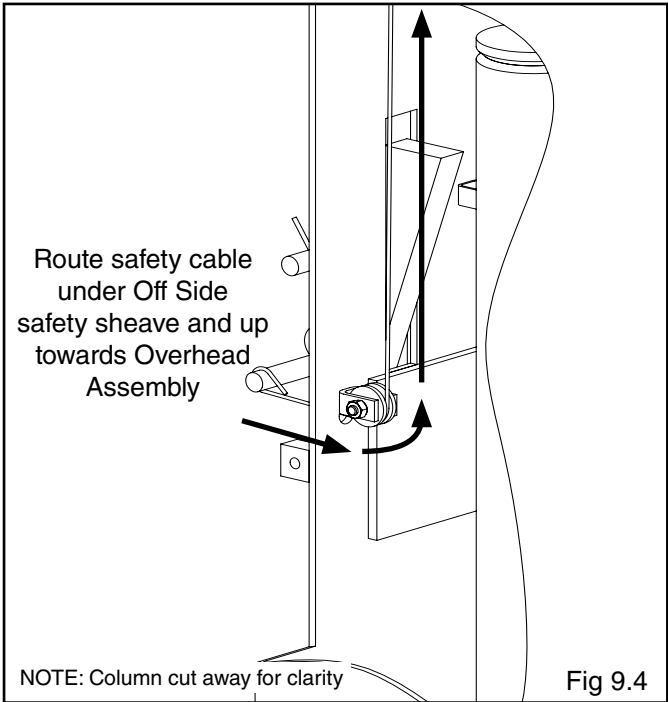
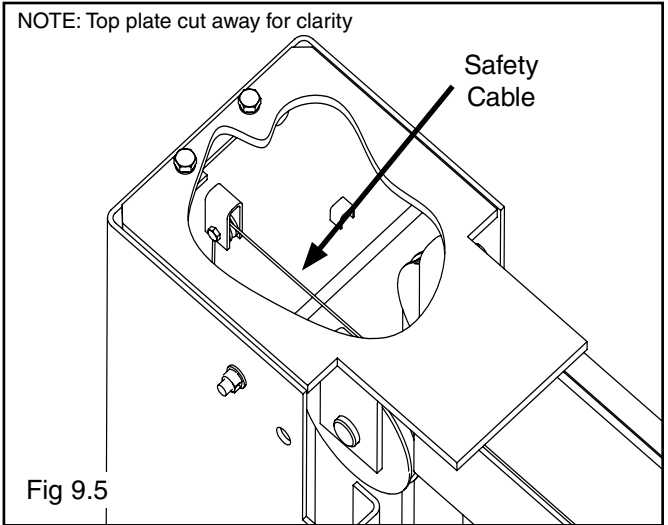
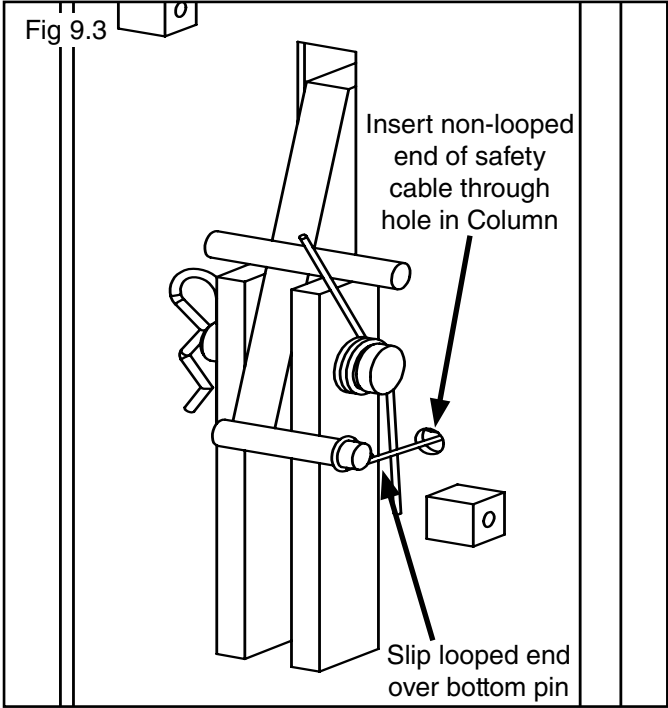

## STEP 10 (Installing Hydraulic Hoses)

1. Install the Hydraulic Tee Fitting into the Power Side Column. The through hole is located approximately 90 inches from the floor on the back wall of the Power Side Column.
2. Connect the **Power Side** Hydraulic Hose to the Tee Fitting. Make sure to route the hose through the Retainer Clips inside the posts.
3. Route the Off Side Hydraulic Hose (Crossover Hose) up through the Column and across the Overhead Assembly, down the Column and connect it to the Tee Fitting. (See Fig 10.1)

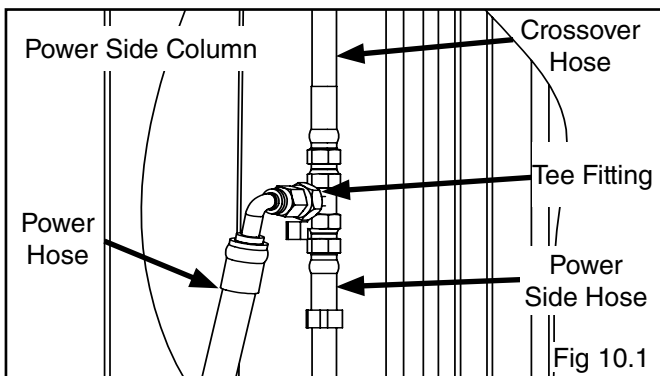

## WARNING

WHEN ROUTING THE HYDRAULIC HOSE THROUGH THE POSTS, MAKE SURE TO ROUTE THROUGH THE HOSE CLIPS INSIDE EACH POST.

MAKE SURE THAT THE HOSE IS CLEAR OF ANY MOVING PARTS. IT MAY BE NECESSARY TO TIE THE HOSE CLEAR BY USING NYLON TIE STRAPS OR WIRE.

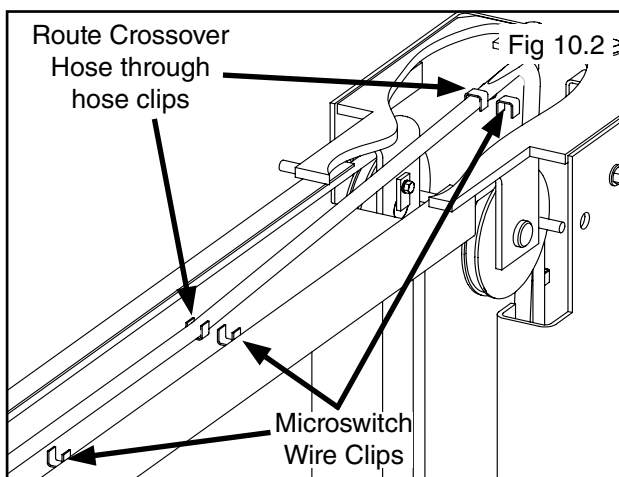

## WARNING

WHEN THE CABLE ADJUSTING NUTS BOTTOM OUT ON THE THREADED END OF THE CABLE CONNECTOR AND THERE IS STILL SLACK IN THE CABLES, THE CABLES HAVE STRETCHED BEYOND THE SAFE USEFUL LENGTH AND NEED TO BE REPLACED WITH FACTORY APPROVED CABLE ASSEMBLIES. DO NOT PLACE WASHERS, SPACERS OR OTHER DEVICES TO "SHORTEN" THE EFFECTIVE CABLE LENGTH AS DAMAGE TO THE LIFT OR INJURY TO PERSONS MAY OCCUR.

## STEP 11

### (Routing the Equalizer Cables)

See drawing on page 13 for reference.

1. Raise and lock each Carriage approximately 28" above the ground. (See Fig. 11.1)

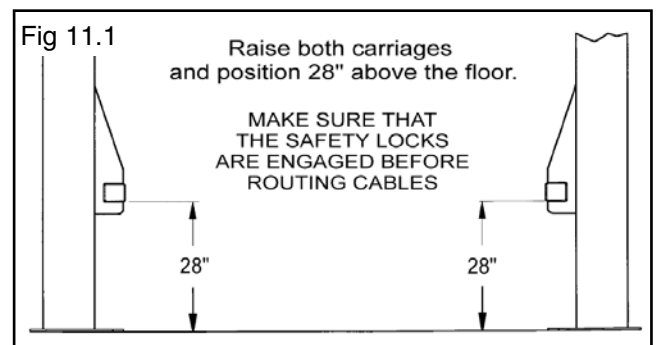

## DANGER

MAKE SURE THAT THE SAFETY LOCKS ON EACH POST ARE FULLY ENGAGED BEFORE ATTEMPTING TO ROUTE EQUALIZER CABLES AND/OR HOSES. CARRIAGES MUST BE EQUAL HEIGHT FROM THE FLOOR BEFORE PROCEEDING.

2. With the Carriages locked at 28" off the floor, route the Equalizer Cables up to the Top Trough.
3. Route the cables through the sheave brackets and reinstall the Cable Sheaves. (See Fig. 11.2)

**Note:** The Cable Sheaves should have been removed in Step 6.

4. Insert the threaded end of the Cable through the hole on top of the carriage. Place M22 Washer and M22 Nylock Nut on threaded cable end. Tighten cable nuts until taut, checking that both cables have equal tension. (See Fig 11.3)

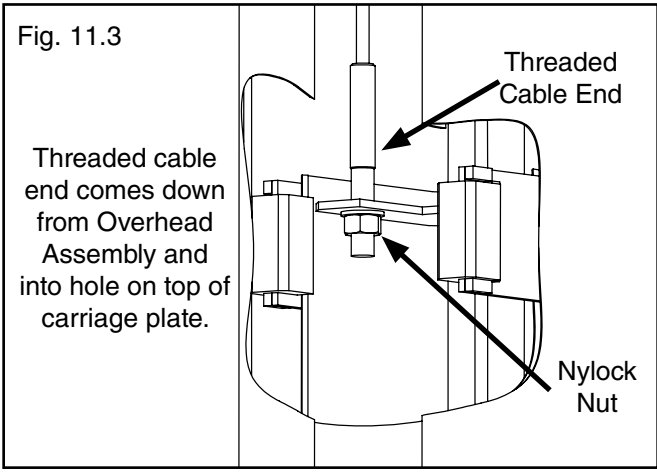
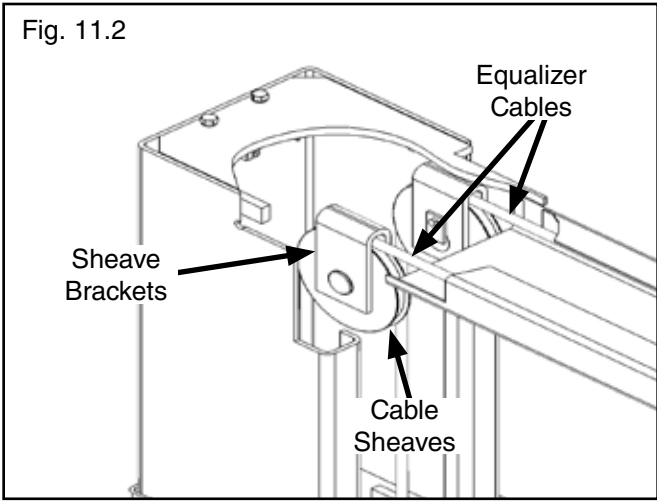

**! DANGER**

ALL WIRING MUST BE PERFORMED BY A LICENSED ELECTRICIAN.

**! DANGER**



DO NOT PERFORM ANY MAINTENANCE OR INSTALLATION OF ANY COMPONENTS WITHOUT FIRST ENSURING THAT ELECTRICAL POWER HAS BEEN DISCONNECTED AT THE SOURCE OR AT POWER PANEL AND CANNOT BE RE-ENERGIZED UNTIL ALL MAINTENANCE AND/OR INSTALLATION PROCEDURES ARE COMPLETED.

**STEP 12**  
**(Installing Overhead Micro Switch)**

**! CAUTION**

MICROSWITCH WIRE MUST BE RUN THROUGH CLIPS IN POST AND OVERHEAD ASSEMBLY. FAILURE TO DO SO CAN CAUSE DAMAGE TO LIFT OR TO VEHICLES.

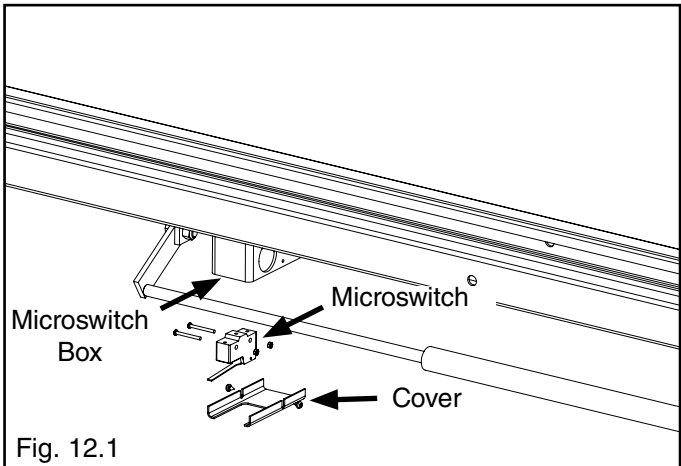

1. Install the overhead Microswitch as shown below. Be sure to keep wire clear of moving parts. (See Fig.12.1)

Note: Second Microswitch for 3 phase wired units ONLY. 3 phase Microswitch Kit can be found in the Power Unit shipping box.

2. Route Microswitch wire through the hole in Power Side Column with rubber grommet. Loosely position Power Side safety cover and run other end of Microswitch wire through hole with grommet in Power Side safety cover. (See Fig. 12.2)

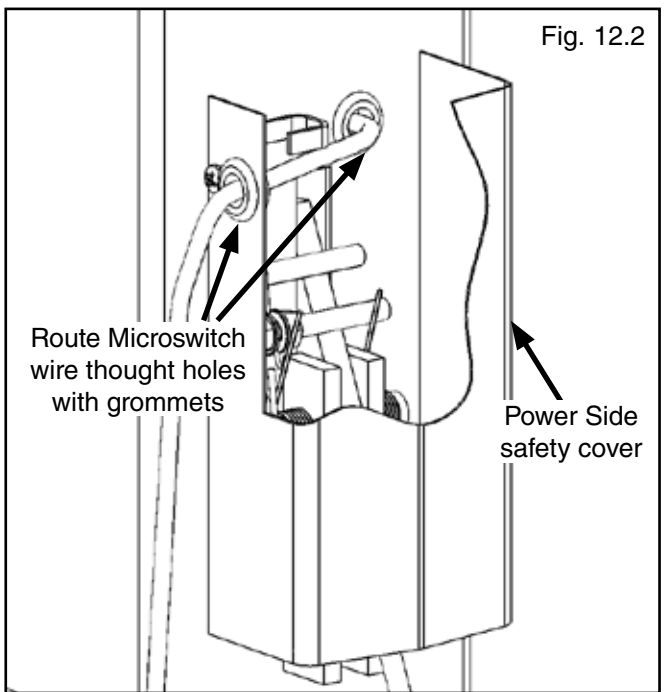

3. Route wire up through Column and across Overhead Assembly through hole in Overhead Assembly into the Microswitch box. (See Fig. 12.3)

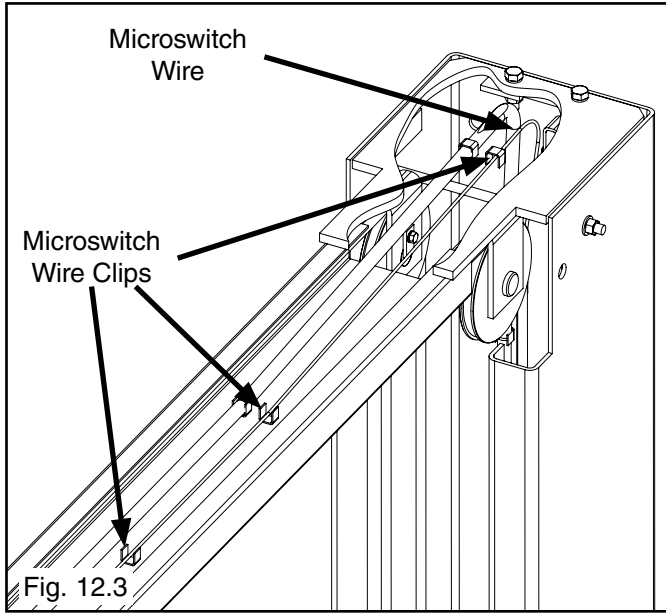

2. Install the Elbow Fitting w/ O-ring into the Hydraulic Pressure Port of the Power Unit. Connect the Power Unit Hose to the Elbow Fitting (See Fig. 13.2)

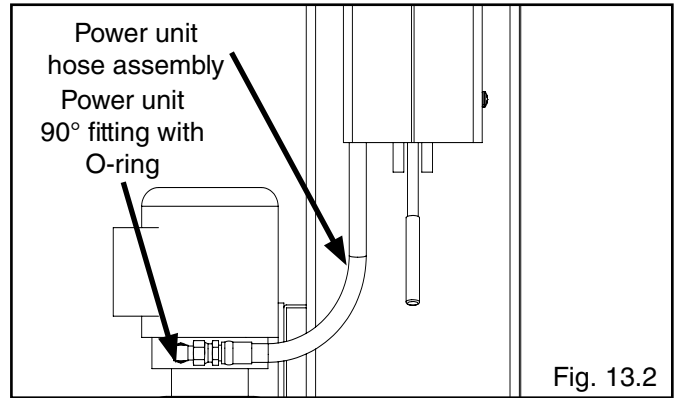

3. Connect other end of Power Unit Hydraulic Hose to the Hydraulic Tee Fitting. (See Fig. 13.3)

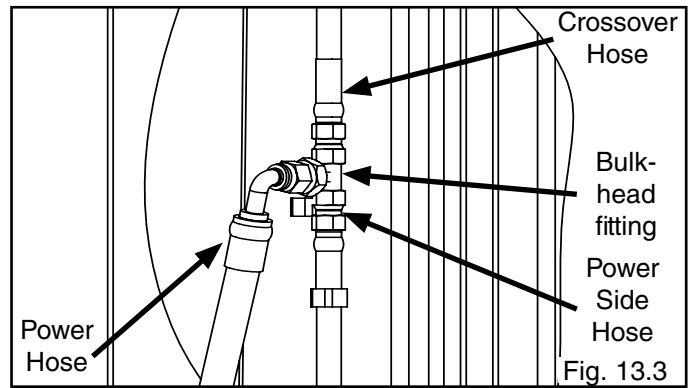

**STEP 13**  
(Installing Power Unit Hose  
and Power Side Safety Cover)



**POWER UNIT HYDRAULIC HOSE MUST BE ROUTED THROUGH THE HOSE CLIPS IN POWER SIDE SAFETY COVER. FAILURE TO DO SO CAN RESULT IN PERSONAL INJURY OR DAMAGE TO THE LIFT.**

1. With Power Side Safety Cover loosely positioned, route Power Unit Hydraulic Hose through clips in Power Side Safety Cover. (See Fig. 13.1)

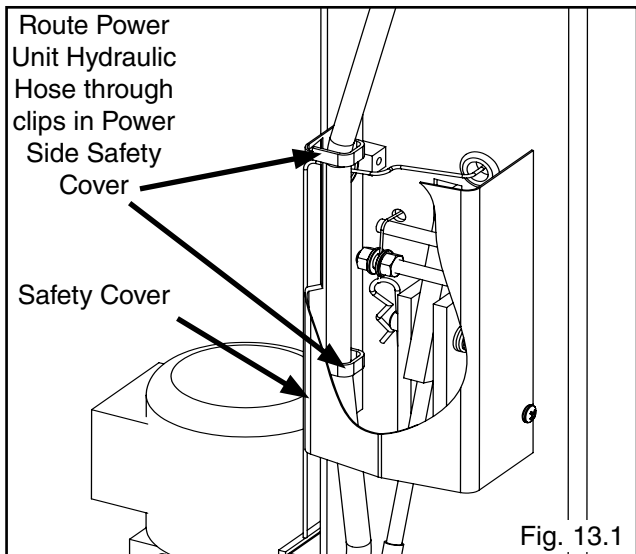

4. After Safeties have been adjusted and checked for proper operation, install and tighten Power Side and Off Side Safety Cover mounting screws. (See Fig. 13.4 and 13.5)

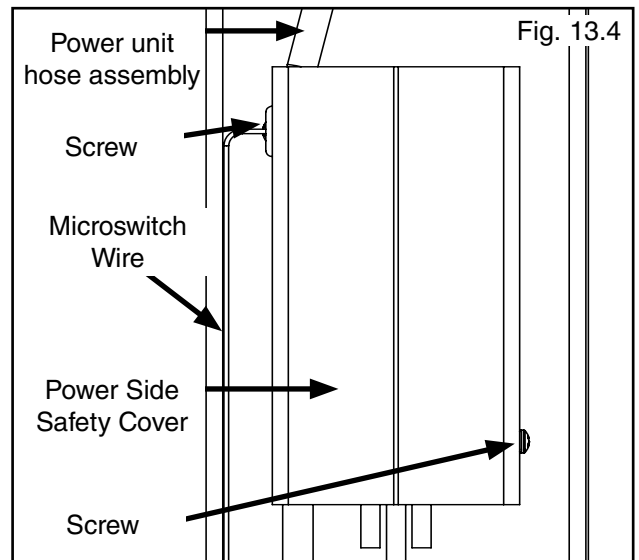

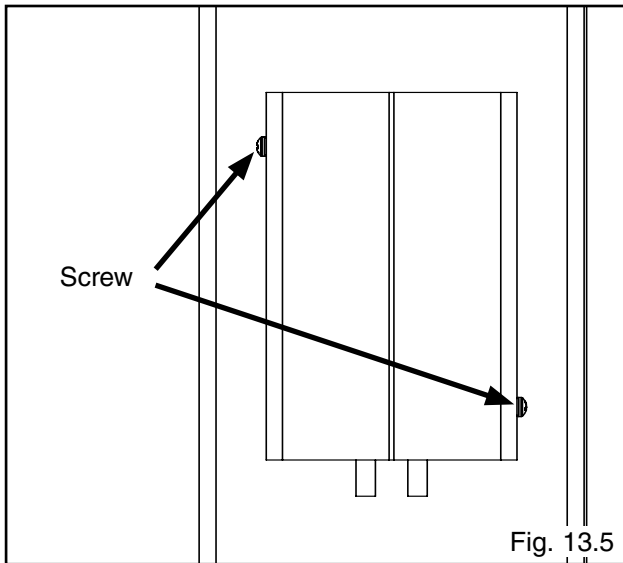

Fig. 13.5

### STEP 14 (Installing the Lift Arms)

1. Place the Lift Arms in the Lift Heads.
2. Install the Lift Head Pins into the Lift Head and through the holes in the Lift Arm (See Fig. 14.1).

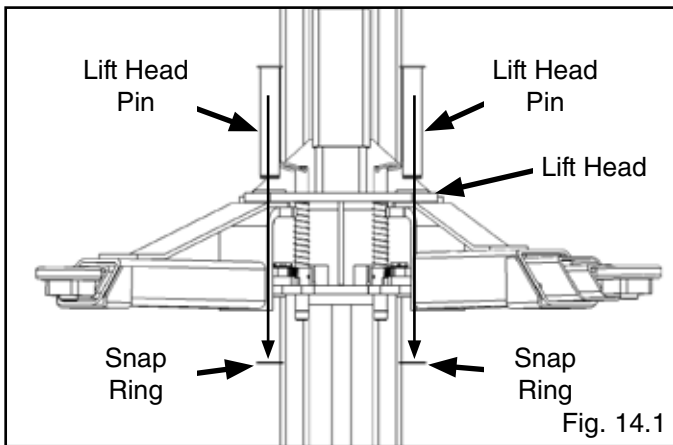

Fig. 14.1

3. Install the snap ring into the groove in the Lift Head Pin on under side of the Lift Head. (See Fig. 14.2)

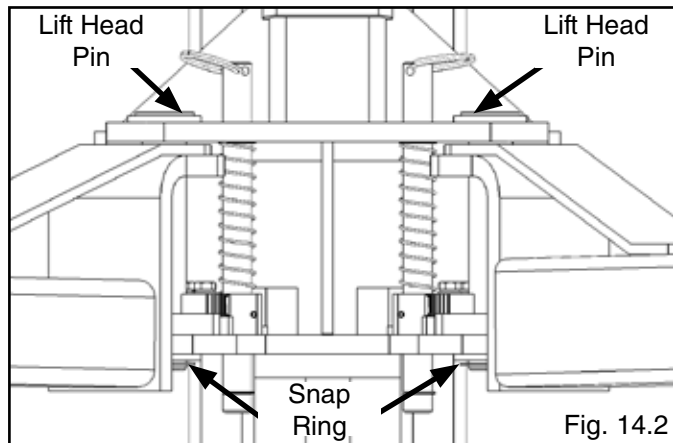

Fig. 14.2



THE ARM RESTRAINT GEARS MUST BE POSITIONED PROPERLY. CONFIRMATION OF PROPER GEAR ENGAGEMENT MUST BE MADE PRIOR TO THE OPERATION OF THE LIFT. PERIODIC INSPECTION IS REQUIRED. FAILURE TO INSPECT THE ARM RESTRAINT GEARS ON ALL FOUR ARMS PROPERLY CAN RESULT IN DAMAGE TO THE VEHICLE OR INJURY AND/OR DEATH.

4. Place each Gear Ring against the Lift Head Pin and align the holes in the Gear Ring with the threaded holes in the Arm Ears. Make sure that the teeth on the Gear Ring mesh smoothly with the teeth on the gears of the Lift Head. (See Fig. 14.3)

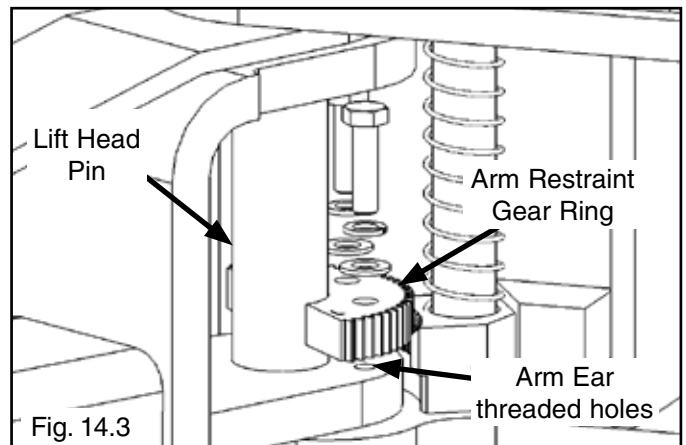

Fig. 14.3

5. Verify the operation of the arm restraints by pulling up on the key ring of the arm restraint pin. Pivot the arms back and forth and test the operation of the arm restraint pin in various positions. (See Fig. 14.4)

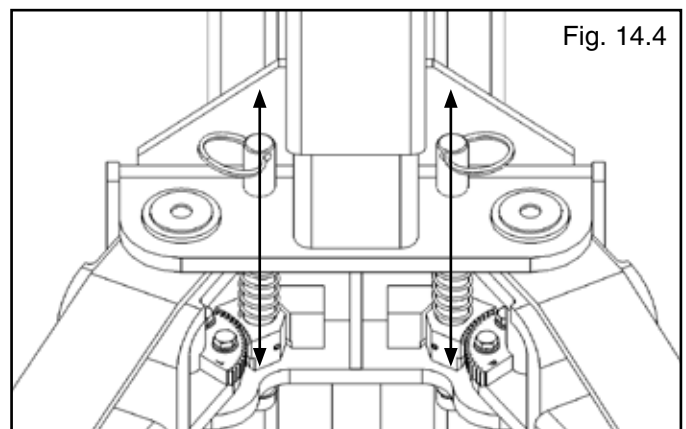

Fig. 14.4

6. Make sure the Lift Arms do not move when a force of approximately 100 pounds or less is applied laterally to the fully extended arms.

**! DANGER**

**NOTE:**  
EACH ARM RESTRAINT ASSEMBLY MUST BE INSPECTED BEFORE **EACH AND EVERY TIME** THE LIFT IS OPERATED.

DO NOT OPERATE THE LIFT IF ANY OF THE FOUR ARM RESTRAINT SYSTEMS ARE NOT FUNCTIONING PROPERLY.

REPLACE ANY BROKEN COMPONENTS OR COMPONENTS WITH BROKEN TEETH ONLY WITH AUTHORIZED OR APPROVED REPLACEMENT PARTS.

**! WARNING**

**IMPORTANT LEVELING INSTRUCTIONS**

Before operating your lift, check to make sure that both "A" and "B" measurements are EQUAL.

The lift arms must be level before operation.

If your lift arms are not level, shim the columns as required.

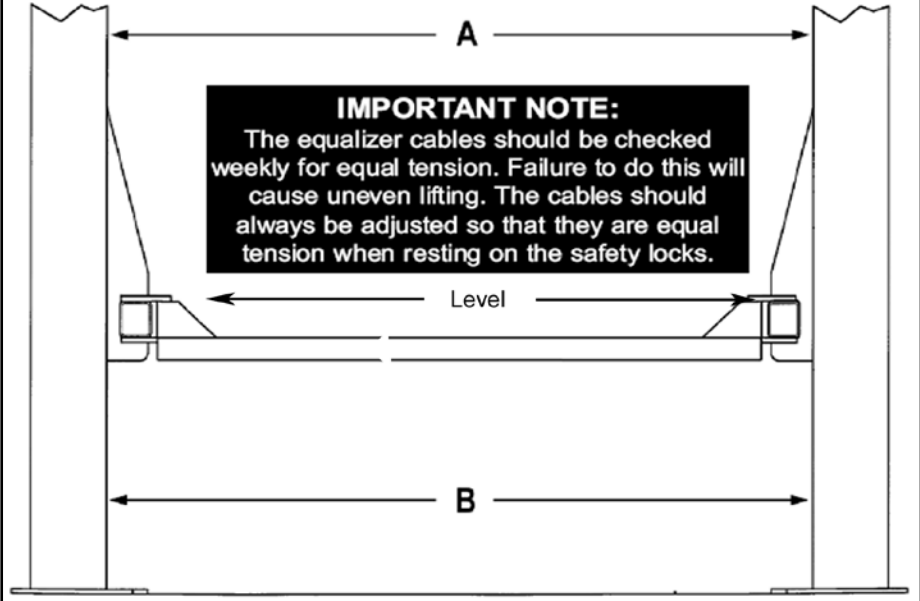

## CARRIAGE STOP BOLT INSTALLATION



YOU MUST RE-INSTALL TOP CARRIAGE-STOP BOLT (SHOWN BELOW). TIGHTEN CARRIAGE-STOP BOLT TO 2-3 POUND FEET OF TORQUE UPON FINAL INSTALLATION INSPECTION. THESE INSTRUCTIONS MUST BE FOLLOWED TO ENSURE PROPER INSTALLATION AND OPERATION OF YOUR LIFT. FAILURE TO COMPLY WITH THESE INSTRUCTIONS CAN RESULT IN SERIOUS BODILY INJURY AND/OR DEATH AND/OR VOID PRODUCT WARRANTY. MANUFACTURER WILL ASSUME NO LIABILITY FOR LOSS OR DAMAGE OF ANY KIND, EXPRESSED OR IMPLIED RESULTING FROM IMPROPER INSTALLATION OR USE OF THIS PRODUCT.

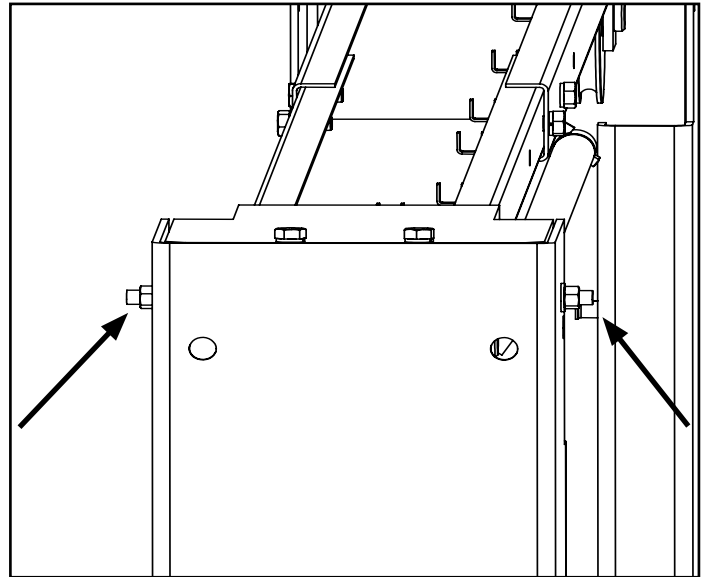
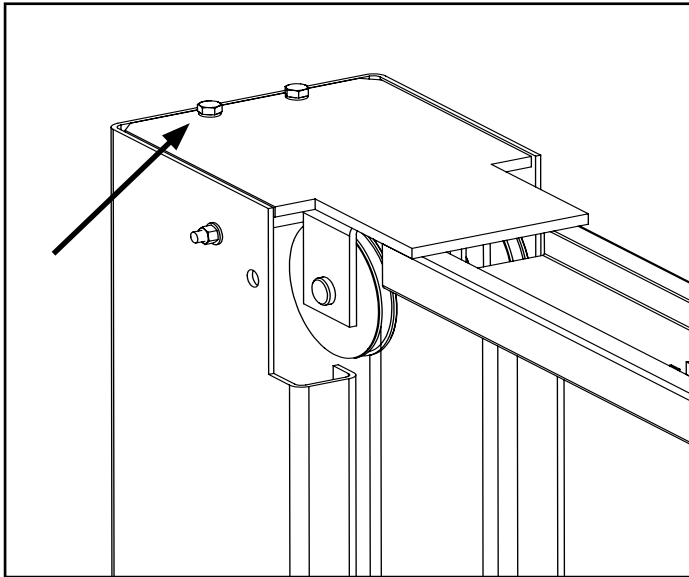





**DO NOT PERFORM ANY MAINTENANCE OR INSTALLATION OF ANY COMPONENTS WITHOUT FIRST ENSURING THAT ELECTRICAL POWER HAS BEEN DISCONNECTED AT THE SOURCE OR PANEL AND CANNOT BE RE-ENERGIZED UNTIL ALL MAINTENANCE AND/OR INSTALLATION PROCEDURES ARE COMPLETED.**



## IMPORTANT POWER-UNIT INSTALLATION NOTES

- DO NOT run Power Unit with no oil. Damage to pump can occur.
- The Power Unit must be kept dry. Damage to Power Unit caused by water or other liquids such as detergents, acid etc., is not covered under warranty.
- Improper electrical hook-up can damage motor and will not be covered under warranty.
- Motor can not run on 50HZ without a physical change in motor.
- Use a separate breaker for each power unit.
- Protect each circuit with time delay fuse or circuit breaker.
- For 208-230 volt, single phase, use a 25 amp fuse.
- For 208-230 volt, three phase, use a 20 amp fuse.
- For 380-440 volt, three phase, use a 15 amp fuse.

DO NOT attempt to raise vehicle until a thorough operation check has been completed.

**ALL WIRING MUST BE PERFORMED BY A CERTIFIED ELECTRICIAN ONLY.**

### Single Phase

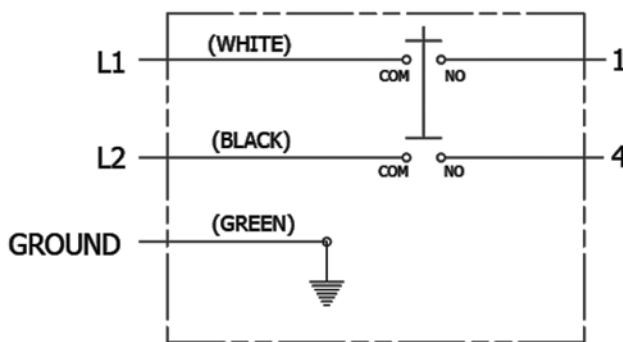

### Three Phase

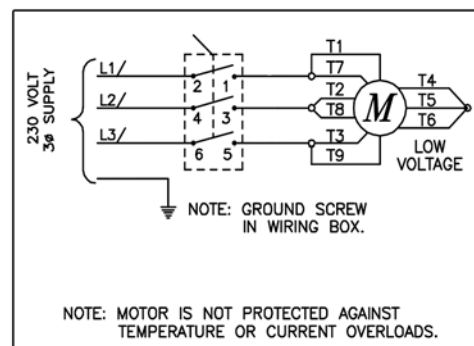

**SEE WIRING INSTRUCTIONS AFFIXED TO MOTOR FOR PROPER WIRING INSTRUCTIONS.**

## STEP 15 (Power Unit Connection)

1. Have a certified electrician run the power supply to motor. Refer to the data plate found on the motor for proper power supply and wire size.



### RISK OF EXPLOSION!

This equipment has internal arcing or parts that may spark and should not be exposed to flammable vapors. Motor should not be located in a recessed area or below floor level. NEVER expose motor to rain or other damp environments. DAMAGE TO MOTOR CAUSED BY WATER IS NOT COVERED UNDER WARRANTY.

### NOTE:

CAUTION NEVER OPERATE THE MOTOR ON LINE VOLTAGE LESS THAN 208V. MOTOR DAMAGE MAY OCCUR WHICH IS NOT COVERED UNDER WARRANTY. HAVE A CERTIFIED ELECTRICIAN RUN APPROPRIATE POWER SUPPLY TO MOTOR. SIZE WIRE FOR 25 AMP CIRCUIT. SEE MOTOR OPERATING DATA TABLE. USE SEPARATE CIRCUIT FOR EACH POWER UNIT. PROTECT EACH CIRCUIT WITH TIME DELAY FUSE OR CIRCUITBREAKER. FOR SINGLE PHASE 208-230V, USE 25 AMP FUSE. THREE PHASE 208-240V, USE 25 AMP FUSE. FOR THREE PHASE 400V AND ABOVE, USE 15 AMP FUSE. ALL WIRING MUST COMPLY WITH NECK AND ALL LOCAL ELECTRICAL CODES.

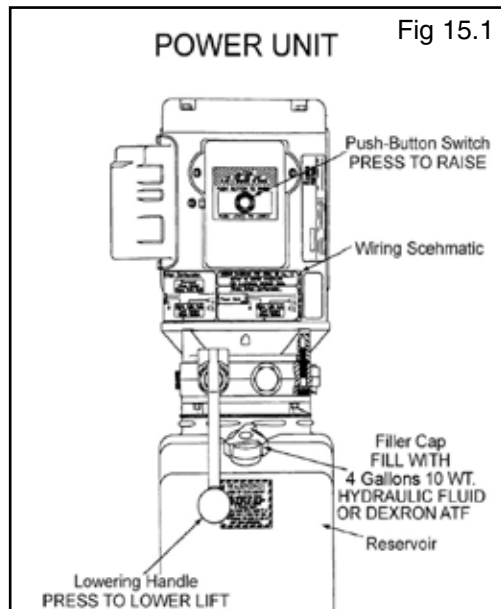

## STEP 16 (Final Adjustments / Post-Installation Checklist)



DURING THE START-UP PROCEDURE, OBSERVE ALL OPERATING COMPONENTS AND CHECK FOR PROPER INSTALLATION AND ADJUSTMENT. DO NOT ATTEMPT TO RAISE VEHICLE UNTIL A THOROUGH OPERATIONAL CHECK HAS BEEN COMPLETED.

1. Check the Hydraulic Fluid Reservoir; it must be full of approved Hydraulic Fluid or automatic transmission fluid. **You can harm the motor by running it without enough fluid.**
2. Apply light axle grease to the inside of the posts where the slide blocks glide.
3. Make sure the Power Unit is getting power from the power source.
4. Check the Hydraulic System for leaks.
5. Make sure both Columns are properly plumbed, shimmed, and stable.
6. Make sure all Cables are properly positioned within the grooves of ALL Cable Sheaves. Make sure all Cable Sheave Retaining Clips/Pins are secure.
7. Make sure that all safety locks are cleared and free.
8. Make sure both Safety Assemblies are connected and working normally.
9. Make sure all Safety Locks are clear and free.
10. Continue to press the button to raise the Lift until the Cables are taut and the Lift starts to move.
11. Check to see that all the Anchor Bolts are properly torqued.
12. Perform an Operational test with a typical Vehicle.

## STEP 17

(Lubrication)

1. After installation and start up has been completed, lubricate lift components as shown below.  
(See Fig. 17.1)

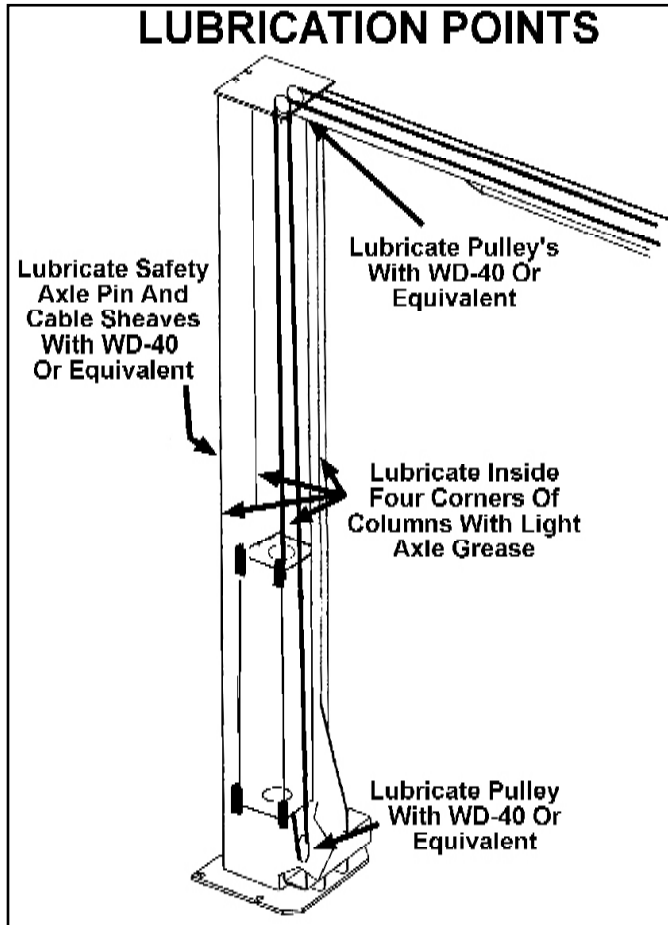

Fig. 17.1

## NOTE:

There will be initial stretching of the cables and/or with increased loads. Adjust the cables as outlined above a week after first use, then every three to six months thereafter depending on usage and/or to compensate for stretch.

## STEP 18

(Bleeding)



**THE LIFT WILL MOVE DOWN WHEN BLEEDING  
MAKE SURE ALL EQUIPMENT, PERSONNEL,  
HANDS AND FEET ARE CLEAR  
BEFORE BLEEDING**

1. After electrical power is connected and the Hydraulic Reservoir is full, press the **Up** Button to raise the Lift.
2. Continue raising until lift cylinders fully extend to full height. **DO NOT** continue pressing button after lift reaches full height. Damage to motor can occur if continued.
3. Lower the lift only **HALF WAY** by pressing the **SAFETY RELEASE** handle inward then pressing in the **DOWN** lever on the power unit.
4. With the lift at half height, slowly loosen the **BLEED SCREWS** located at the top of each cylinder to bleed trapped air. **DO NOT** completely remove bleed screws. Re-tighten after trapped air has escaped. (See Fig. 18.1)

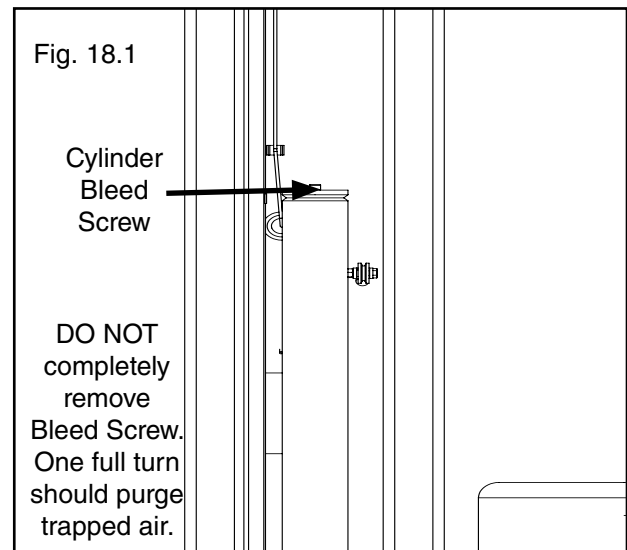

5. Lower the lift completely by pressing the **SAFETY RELEASE** handle inward then pressing the **DOWN** lever on power unit. Wait five minutes and repeat bleeding process one additional time.

## STEP 19 (Operation Instructions)

### OWNER/EMPLOYER RESPONSIBILITIES

#### The Owner/Employer:

- Shall ensure that lift operators are qualified and that they are trained in the safe use and operation of the lift using the manufacturer's operating instructions; ALI/SM 10-01, ALI Lifting It Right safety manual; AL-ST-17 ALI Safety Tips card; ANSI/ALI ALOIM:2008 (R2013), American National Standard for Automotive Lifts-Safety Requirements for Operation, Inspection and Maintenance; ALI/WL Series, ALI Uniform Warning Label Decals/Placards; and in the case of frame engaging lifts, ALI/LP-GUIDE, Vehicle Lifting Points/Quick Reference Guide for Frame Engaging Lifts.
- Shall establish procedures to periodically inspect the lift in accordance with the lift manufacturer's instructions or ANSI/ALI ALOIM:2008 (R2013), American National Standard for Automotive Lifts-Safety Requirements for Operation, Inspection and Maintenance; and The Employer shall ensure that lift inspectors are qualified and that they are adequately trained in the inspection of the lift.
- Shall establish procedures to periodically maintain the lift in accordance with the lift manufacturer's instructions or ANSI/ALI ALOIM:2008 (R2013), American National Standard for Automotive Lifts-Safety Requirements for Operation, Inspection and Maintenance; and the Employer shall ensure lift maintenance personnel are qualified and that they are adequately trained in the maintenance of the lift.
- Shall maintain the periodic inspection and maintenance records recommended by the manufacturer or ANSI/ALI ALOIM:2008 (R2013), American National Standard for Automotive Lifts-Safety Requirements for Operation, Inspection and Maintenance.

### LIFT OPERATION SAFETY

- **DAILY** inspect your lift. Never operate if Lift malfunctions or if it has broken or damaged parts. Use **only** qualified lift service personnel and genuine Danmar parts to make repairs.
- **THOROUGHLY** train all employees in use and care of lift, using manufacturer's instructions and "Lifting It Right" and "Safety Tips" supplied with the lift.
- **NEVER** allow unauthorized or untrained persons to position vehicle or operate lift.
- **PROHIBIT** unauthorized persons from being in Lift area while lift is in use.
- **DO NOT** permit anyone on lift or inside vehicle when it is either being raised or lowered.

- Shall display the lift manufacturer's operating instructions; ALI/SM 10-01, ALI Lifting It Right safety manual; AL-ST-17 ALI Safety Tips card; ANSI/ALI ALOIM:2008 (R2013), American National Standard for Automotive Lifts-Safety Requirements for Operation, Inspection and Maintenance; and in the case of frame engaging lifts, ALI/LP-GUIDE, Vehicle Lifting Points/Quick Reference Guide for Frame Engaging Lifts; in a conspicuous location in the lift area convenient to the operator.
- Shall provide necessary lockout/tagout means for energy sources per ANSI Z244.1-2016, Safety Requirements for the Lockout/Tagout of Energy Sources, before beginning any lift repairs.
- Shall not modify the lift in any manner without the prior written consent of the manufacturer.



- **ALWAYS** keep area around lift free of tools, debris, grease and oil.
- **NEVER** overload lift. Capacity of lift is shown on nameplate affixed to the lift.
- **DO NOT** stand in front of the vehicle while it is being positioned in lift bay.
- **DO NOT** hit or run over lift arms or adapters. This could damage lift or vehicle.
- Before driving vehicle into lift bay, position arms and adapters to provide unobstructed entrance onto lift.

## LIFT OPERATION SAFETY (CONTINUED)

- **ALWAYS** carefully load Vehicle on the Lift. Position the lift adapters to contact at the Vehicle Manufacturer's recommended lift points. Raise lift until adapters contact vehicle. Check adapters for secure contact with Vehicle. Raise lift to desired working height. (See Fig.19.1)

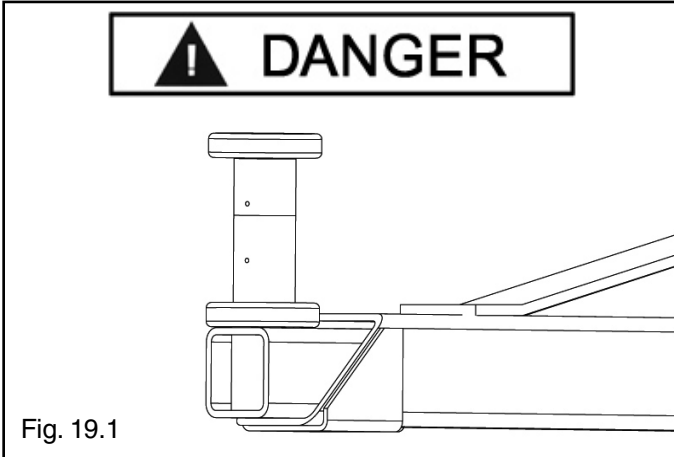

- **DO NOT** block open or override self-closing lift controls; they are designed to return to the "Off" or Neutral position when released.
- **DO NOT** remove or disable arm restraints.
- **ALWAYS** remain clear of Lift when raising or lowering Vehicles.
- **ALWAYS** use safety stands when removing or installing heavy components.
- **NEVER** go under a raised Vehicle if safety locks are not engaged.



VISUALLY CONFIRM THAT ALL PRIMARY SAFETY LOCKS ARE ENGAGED BEFORE ENTERING WORK AREA. SUSPENSION COMPONENTS USED ON THIS LIFT ARE INTENDED TO RAISE AND LOWER LIFT ONLY AND ARE NOT MEANT TO BE LOAD HOLDING DEVICES. REMAIN CLEAR OF ELEVATED LIFT UNLESS VISUAL CONFIRMATION IS MADE THAT ALL PRIMARY SAFETY LOCKS ARE FULLY ENGAGED AND THE LIFT IS LOWERED ONTO THE SAFETY LOCKS, REFER TO INSTALLATION/OPERATION MANUAL FOR PROPER SAFETY LOCK PROCEDURES AND/OR FURTHER INSTRUCTION.

- **NEVER LEAVE LIFT IN ELEVATED CONDITION** unless all Safety Locks are engaged.
- **AVOID** excessive rocking of Vehicle while on Lift.



WHEN LOWERING THE LIFT PAY CAREFUL ATTENTION THAT ALL PERSONNEL AND OBJECTS ARE KEPT CLEAR. ALWAYS KEEP A VISUAL LINE OF SITE ON THE LIFT AT ALL TIMES. ALWAYS MAKE SURE THAT ALL LOCKS ARE DISENGAGED. IF ONE OF THE LOCKS INADVERTENTLY LOCKS UPON DESCENT THE VEHICLE MAY DISMOUNT CAUSING PERSONAL INJURY OR DEATH.

- **ALWAYS CLEAR AREA** if Vehicle is in danger of falling.
- **ALWAYS REMOVE** tool trays, stands, etc. before lowering lift.
- **ALWAYS RELEASE** Safety Locks before attempting to lower lift.
- **ALWAYS POSITION** the Lift Arms and Adapters to provide an unobstructed exit before removing Vehicle from lift area.

### TO RAISE THE LIFT

1. Before Loading: Lift must be fully lowered and service bay clear of all personnel before the Vehicle is brought on Lift with the swing arms set to the full drive-thru position.



TO AVOID PERSONAL INJURY AND/OR PROPERTY DAMAGE, PERMIT ONLY TRAINED PERSONNEL TO OPERATE LIFT. AFTER REVIEWING THESE INSTRUCTIONS, PRACTICE USING LIFT CONTROLS BY RUNNING THE LIFT THROUGH A FEW UNLOADED CYCLES BEFORE LOADING VEHICLE ON LIFT. ALWAYS LIFT THE VEHICLE USING ALL FOUR ADAPTERS. NEVER RAISE JUST ONE END, ONE CORNER, OR ONE SIDE OF VEHICLE.

2. Loading: Swing arms under Vehicle and position Adapters at Vehicle manufacturer's recommended Lift Points. Use height extenders or optional frame-cradle adapters when necessary to ensure good contact. (See Fig 19.2 - 19.3)
3. Some vehicles may have the manufacturer's Service Garage Lift Point locations identified by triangle shape marks on the undercarriage (reference ANSI/SAE J2184-1992). Also, there may be a label located on the right front door jamb area showing specific vehicle lift points.

## LIFT OPERATION SAFETY (CONT'D)

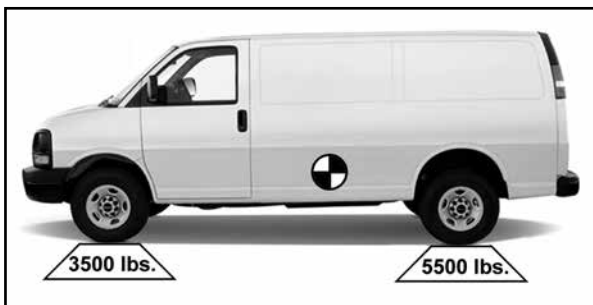
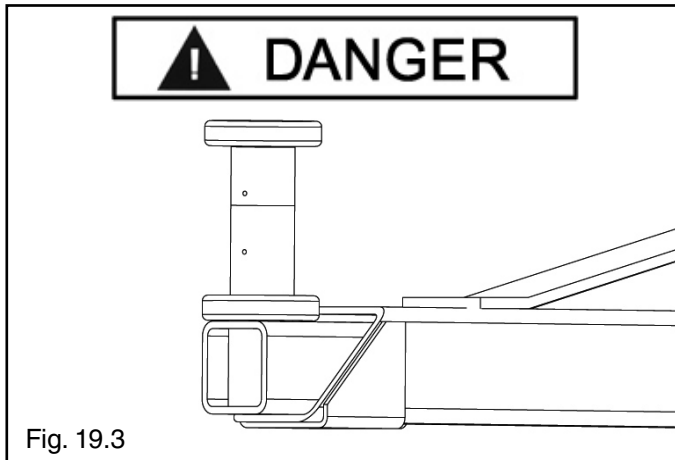
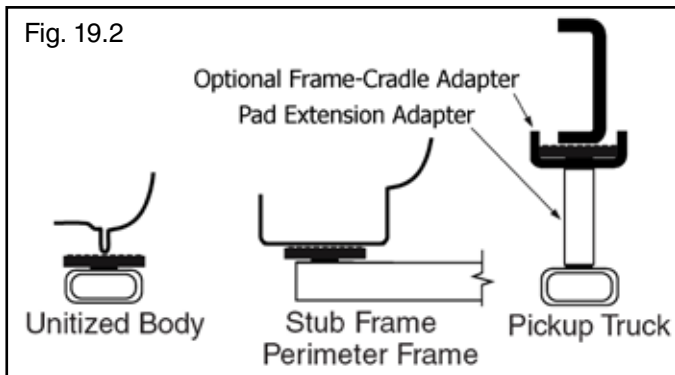

- Position Vehicle for proper weight distribution arms under Vehicle to allow adapters to contact at the manufacturer's recommended lifting points.
- Push the **RAISE** button or rotate the control switch on the power unit.

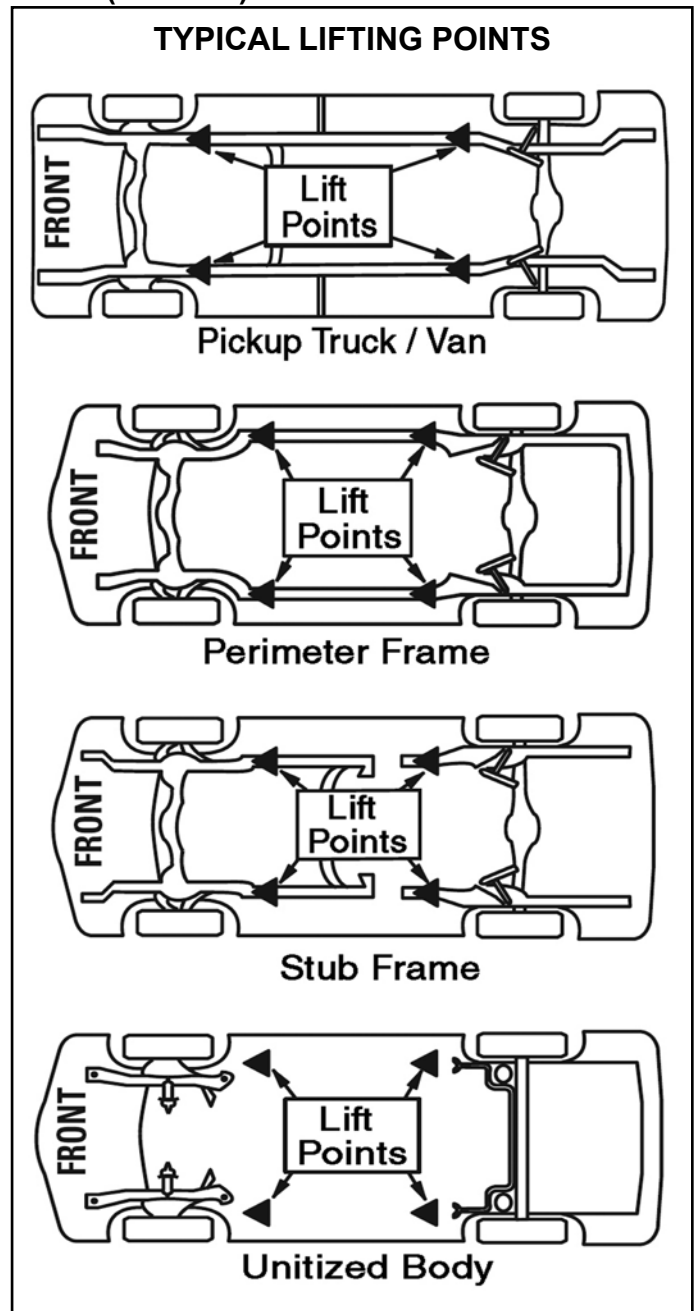

**NOTE:**  
ALLOW (2) SECONDS BETWEEN MOTOR STARTS. FAILURE TO COMPLY MAY CAUSE MOTOR BURNOUT.

- Stop before making contact with Vehicle. Check arm restraint pins for engagement. If required, slightly move arm to allow restraint gear and pawl to mesh. **DO NOT** hammer arm restraint pin down as this will damage the restraint gear teeth.
- Raise Vehicle until tires clear the floor.
- Stop and check adapters for secure contact at vehicle manufacturer's recommended lift points.
- Continue to raise to desired height only if vehicle is secure on lift.

## LIFT OPERATION SAFETY (CONTINUED)

11. **DO NOT** go near or under a raised Vehicle if all four adapters are not in secure contact with vehicle at vehicle manufacturer's recommended lift points.
12. Repeat entire loading and raising procedures if required.
13. Lower Lift onto safety locks.



VISUALLY CONFIRM THAT ALL PRIMARY SAFETY LOCKS ARE ENGAGED BEFORE ENTERING WORK AREA. SUSPENSION COMPONENTS USED ON THIS LIFT ARE INTENDED TO RAISE AND LOWER LIFT ONLY AND ARE NOT MEANT TO BE LOAD HOLDING DEVICES. REMAIN CLEAR OF ELEVATED LIFT UNLESS VISUAL CONFIRMATION IS MADE THAT ALL PRIMARY SAFETY LOCKS ARE FULLY ENGAGED AND THE LIFT IS LOWERED ONTO THE SAFETY LOCKS, REFER TO INSTALLATION / OPERATION MANUAL FOR PROPER SAFETY.

- **CLEAR AREA** if vehicle is in danger of falling.
- **DO NOT** position yourself between a wall and the lift. If the vehicle falls in that direction, you may be severely injured or killed.
- Before attempting to lift pickup trucks or other truck frame vehicles, be sure that:
  - ◆ Vehicle frame is strong enough to support its weight and has not been weakened by modification or corrosion.
  - ◆ Vehicle individual axle weight does not exceed one-half lift capacity.
  - ◆ Adapters are in secure contact with frame at vehicle manufacturers recommended lift points.
  - ◆ Vehicle is stable on lift and the center of gravity is NOT off balance.
  - ◆ The overhead switch bar will contact the highest point on the vehicle.

### WHILE USING LIFT

- Avoid excessive rocking of Vehicle while on lift.
- Always use safety stands as needed or when removing or installing heavy components.



WHEN LOWERING THE LIFT PAY CAREFUL ATTENTION THAT ALL PERSONNEL AND OBJECTS ARE KEPT CLEAR. ALWAYS KEEP A VISUAL LINE OF SITE ON THE LIFT AT ALL TIMES. ALWAYS MAKE SURE THAT ALL LOCKS ARE DISENGAGED. IF ONE OF THE LOCKS INADVERTENTLY LOCKS ON DESCENT THE LIFT AND/OR VEHICLE MAY DISRUPT CAUSING PERSONAL INJURY OR DEATH.

### TO LOWER THE LIFT

1. Remove all tools or other objects from the lift area.
2. Press and hold the Up Button for a few seconds to move the Lift off the Safety Locks.
3. Pull down and hold Safety Lock Release Handle.
4. Push and hold the Lowering Handle.

**NOTE:** Both Safety Release Handle **AND** Lowering Handle **must be held down at the same time** to lower the Lift. Do not override self-closing lift controls.

5. Remain clear of Lift when lowering vehicle. Observe pinch point warning decals.
6. Remove adapters from under vehicle and swing arms to full drive-thru position before moving vehicle.
7. Drive the Vehicle out.



IF YOU ARE NOT COMPLETELY FAMILIAR WITH AUTOMOTIVE LIFT MAINTENANCE PROCEDURES; STOP AND CONTACT THE MANUFACTURER FOR INSTRUCTIONS. TO AVOID PERSONAL INJURY, PERMIT ONLY QUALIFIED PERSONNEL TO PERFORM MAINTENANCE ON THIS EQUIPMENT.

### MAINTENANCE INSTRUCTIONS

- Always keep bolts tight. Check periodically.
- Always keep lift components clean.
- Always if oil leakage is observed, call local service representative.
- Always call local service representative if electrical problems develop.

## LIFT OPERATION SAFETY (CONT'D)

- Always replace ALL FAULTY PARTS before lift is put back into operation.
- Daily: Make a visual inspection of ALL MOVING PARTS and check for excessive signs of wear.
- Daily: Check safety locks to ensure they are in good operating condition.
- Daily: Check cables and sheaves for wear. Replace worn parts as required with genuine BendPak parts.
- Daily: Inspect adapters for damage or excessive wear. Replace as required with genuine BendPak parts.
- Weekly: Lubricate all sheave and rollers with general purpose oil.
- Weekly: Check all cable connections, bolts and pins to ensure proper mounting.
- Monthly: Check equalizer cable tension. Adjust per lift installation instructions.
- Monthly: Lubricate locking latch shafts. Push latch handle several times for oil to penetrate pivot points.
- Every 3 Months: Check anchor bolt torque. Anchors should be torqued to 90 ft/lbs.
- Semi-Annually: Check fluid level of lift power unit and refill if required per lift installation instructions.
- Replace all caution, warning or safety related decals on the lift if unable to read or missing. Reorder labels from BendPak.
- Refer to ANSI/ALI ALOIM booklet for periodic inspection checklist and maintenance log sheet.



Before lifting the vehicle, make sure it is neither front nor rear heavy. See image below. Center of balance should be midway between adapters.

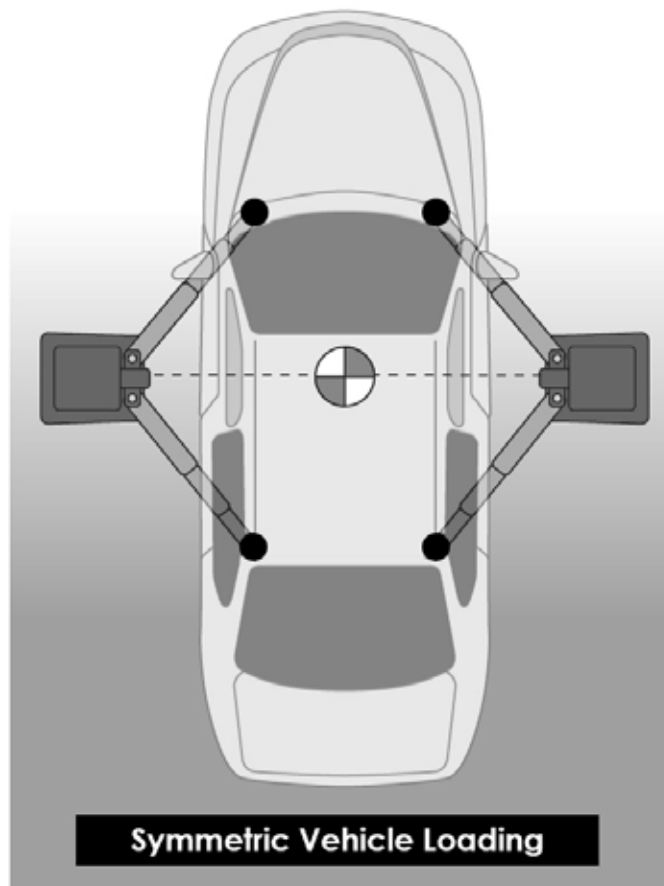



## TO RAISE LIFT

- ◆ Read operating and Safety manuals before using lift.
- ◆ Always lift a vehicle according to the manufacturers recommended lifting points.
- ◆ Position vehicle between columns.
- ◆ Adjust swing arms so that the vehicle is positioned with the center of gravity midway between pads.
- ◆ Use truck adapters as needed. Never exceed 9" of Pad height.
- ◆ **NEVER** use lift pad assemblies without rubber slip over pads in place.
- ◆ Raise the vehicle by depressing button until the vehicle just lifts off the ground. Re-check to make sure the vehicle is secure and all locking pins are lock in place.
- ◆ Raise vehicle to desired height. Lower vehicle onto nearest safety,
- ◆ Always ensure safeties are engaged before any attempt is made to work on or near vehicle.

## TO LOWER THE LIFT

- ◆ First raise the lift clear to the safeties.
- ◆ Release safeties by pulling on the safety handle.
- ◆ Be sure tool trays, stands or personnel are cleared from under the vehicle.
- ◆ Lower vehicle by activating lowering handle on power unit.
- ◆ Before removing vehicle from lift; position lift arms and supports to provide an unobstructed exit.
- ◆ **NEVER**, drive over lift arms.

## REQUIRED MONTHLY MAINTENANCE

- ◆ Check all arm adjusting locks for proper operation.
- ◆ Check all cables connections, bolts and pins to ensure proper mounting and torque.
- ◆ Visually inspect safeties for proper operation.
- ◆ Lubricate columns with grease.
- ◆ Inspect all anchors bolts and retighten if necessary.
- ◆ Check all columns for squareness and plumb.
- ◆ Inspect all pivot arms pins making sure they are properly secure.
- ◆ Check equalizer cable tension, and adjust if necessary.
- ◆ If lift is equipped with over head cut-off switch, check for proper operation.



1. **WARNING!** If cement anchor bolts are loose or any component of the lift is found to be defective, **DO NOT USE THE LIFT!!**
2. Never operate the lift with any person or equipment below the vehicle.
3. Never exceed the rated lift capacity.
4. Always ensure the safeties are engaged before any attempt is made to work on or near the vehicle.
5. Never leave lift in elevated position unless the safeties are engaged.
6. Do not permit electric motor to get wet! Motor damage caused by dampness is not covered under warranty.



**NEVER LIFT ANY VEHICLE IN ANY MANNER WITH LESS THAN ALL FOUR (4) ARMS. RATED CAPACITY OF EACH LIFT ARM IS NO GREATER THAN ONE FOURTH (1/4) OF THE OVERALL LIFT CAPACITY.**



## WARNING

### WIRE ROPE INSPECTION AND MAINTENANCE

- ◆ Lifting cables should be replaced every three - five years or when visible signs of damage are apparent. **DO NOT USE LIFT WITH DEFECTIVE / WORN CABLES.**
- ◆ Lifting cables should be maintained in a well-lubricated condition at all times. Wire rope is only fully protected when each wire strand is lubricated both internal and external. Excessive wear will shorten the life of the wire rope. The factory suggested wire rope lubricant that penetrates to the core of the rope and provides long-term lubrication between each individual strand is 90-WT gear oil or ALMASOL® Wire Rope Lubricant. In order to make sure that the inner layers of the rope remain well lubricated, lubrication should be carried out at intervals not exceeding three months during operation.
- ◆ All sheaves and guide rollers in contact with the moving rope should be given regular visual checks for surface wear and lubricated to make sure that they run freely. This operation should be carried out at appropriate intervals generally not exceeding three months during operation. For all sheave axles, the factory recommends standard wheel bearing grease. For all sheaves and/or guide rollers, the factory recommends 90-WT gear oil or similar heavy lubricant applied by any method including pump / spray dispensing, brush, hand and/or swabbing.

### HOW OFTEN TO INSPECT

- ◆ Lifting cables should be visually inspected at least once each day when in use, as suggested by American Petroleum Institute (API) RP54 guidelines.
- ◆ Any lifting cables that have met the criteria for removal must be immediately replaced.

### WHEN TO REPLACE LIFTING CABLES DUE TO BROKEN WIRES

- ◆ Lifting cables should be removed from service when you see six randomly distributed broken wires within any one lay length, or three broken wires in one strand within one lay length.

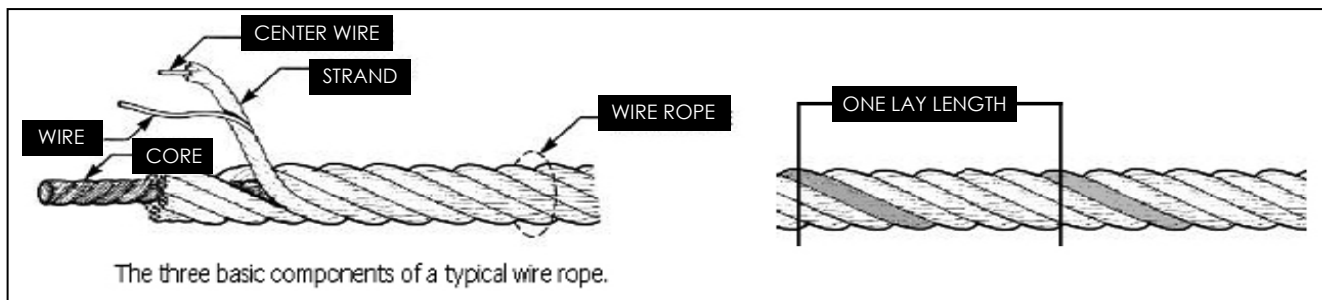

### OTHER REASONS TO REPLACE LIFTING CABLES

- ◆ Corrosion that pits the wires and/or connectors.
- ◆ Evidence of kinking, crushing, cutting, bird-caging or a popped core.
- ◆ Wear that exceeds 10% of a wire's original diameter.
- ◆ Evidence of heat damage.

### HOW TO FIND BROKEN WIRES

- ◆ The first step is to relax your rope to a stationary position and move the pick-up points off the sheaves. Clean the surface of the rope with a cloth — a wire brush, if necessary — so you can see any breaks.
- ◆ Flex the rope to expose any broken wires hidden in the valleys between the strands.
- ◆ Visually check for any broken wires. One way to check for crown breaks is to run a cloth along the rope to check for possible snags.
- ◆ With an awl, probe between wires and strands and lift any wires that appear loose. Evidence of internal broken wires may require a more extensive rope examination.

## Safe Lift Operation

It is your responsibility to **operate your lift safely**.

Lift training should include, but not be limited to, the following:

- Proper positioning of the vehicle on the lift arms. (See manufacturers minimize wheel base loading requirements.)
- Use of the operating controls.
- Understanding the lift capacity.
- Proper use of jack stands or other load supporting devices.
- Proper use, understanding and visual identification of safety lock devices and their operation.
- Reviewing the safety rules.
- Proper housekeeping procedures (lift area should be free of grease, oil, tools, equipment, trash, and other debris).
- A daily inspection of the lift should be completed prior to its use. Safety devices, operating controls, lift arms and other critical parts should be inspected prior to using the lift.
- All maintenance and repairs of the lift should be completed by following the manufacturer's requirements. Lift repair parts should meet or exceed OEM specifications. Repairs should only be completed by a qualified lift technician.
- The vehicle manufacturer's recommendations should be used for spotting and lifting the vehicle.

Other important safety rules include:

- It is important that you know the load limit. Never overload the lift. If you are unsure what the load limit is, check the data plate found on one of the lift columns or contact the manufacturer.
- Make sure any vehicle you put onto the lift is balanced. Always use the manufacturer's recommended lifting points.
- Always make sure you have proper overhead clearance. Additionally, check that attachments (vehicle signs, campers, antennas, etc.) are not in the way.
- Be sure that prior to the vehicle being raised, the doors, trunk, and hood are closed securely.
- Prior to being raised, make sure there is no one standing closer than six feet from the lift.
- After positioning the vehicle on the lift runways, set the emergency brake, make sure the ignition is off, the doors are closed, overhead obstructions are cleared, and the transmission is in neutral.
- Double check that the automatic chock devices are in position and then when the lift is raised, observe the chocks.
- Put pads or adapters in the right position under the contact points that have been recommended.
- The lift should be raised just until the vehicle's wheels are about one foot off the ground. If contact with the vehicle is uneven or it appears that the vehicle is not sitting secure, carefully lower the lift and readjust.
- Always consider potential problems that might cause a vehicle to slip, i.e., heavy cargo, undercoating, etc.
- Pay attention when walking under a vehicle that is up on the hydraulic lift.



- **Do not** leave the controls while the lift is still in motion.
- **Do not** stand directly in front of the vehicle or in the bay when vehicle is being loaded or driven into position.
- **Do not** go near vehicle or attempt to work on the vehicle when being raised or lowered.
- **Remain clear** of lift when raising or lowering vehicle.
- Do not rock the vehicle while on the lift or remove any heavy component from vehicle that may cause excessive weight shift.
- Do not lower the vehicle until people, materials, and tools are clear.
- Make sure the safeties are engaged and lowered on to the safety ladders before any attempt is made to work on or near a vehicle.
- Some vehicle maintenance and repair activities may cause the vehicle to shift. Follow the manufacturer's guidelines when performing these operations. The use of jack stands or alternate lift points may be required when completing some repairs.
- **READ AND UNDERSTAND** all safety warning procedures before operating lift.
- **KEEP HANDS AND FEET CLEAR.** Remove hands and feet from any moving parts. Keep feet clear of lift when lowering. Avoid pinch points.
- **ONLY TRAINED OPERATORS** should operate this lift. All non-trained personnel should be kept away from work area. Never let non-trained personnel come in contact with, or operate lift.
- **USE LIFT CORRECTLY.** Use lift in the proper manner. Never use lifting adapters other than what is approved by the manufacturer.
- Do not override self-closing lift controls.
- **CLEAR AREA** if vehicle is on danger of falling.
- **STAY ALERT.** Watch what you are doing. Use common sense. Be aware.
- **CHECK FOR DAMAGED PARTS.** Check for alignment of moving parts, breakage of parts or any condition that may affect its operation. Do not use lift if any component is broken or damaged.
- Never remove safety related components from the lift. Do not use lift if safety related components are damaged or missing. Never
- When the lift is being lowered, make sure everyone is standing at least six feet away.
- Be sure there are no jacks, tools, equipment, left under the lift before lowering.
- Always lower the vehicle down slowly and smoothly.

## TROUBLESHOOTING

Issue	Action to take
Lift does not raise or does not lower once raised.	<p>Make sure there is sufficient Hydraulic Fluid in the Reservoir.</p> <p>Make sure there is no air in the Hydraulic System.</p> <p>Make sure none of the Hydraulic Hoses are pinched or leaking.</p> <p>Make sure the Power Unit is getting power.</p> <p>If the Hydraulic Fluid is dirty, replace it with clean fluid.</p> <p>Make sure the Lift is not overloaded. Make sure the load on the Lift is balanced.</p>
Lift Arms move erratically or squeak when in use.	<p>Move the Arms up and down a few times to flush any residual air from the Hydraulic System.</p>
Lift does not stay up.	<p>Make sure to leave the Lift engaged on its Safety Locks.</p> <p>Check for Hydraulic Fluid leaks.</p>
Vehicle on the Lift is not level.	<p>Make sure Lift is engaged on its Safety Locks at the same height. Make sure the Safety Locks in both Posts are engaged.</p> <p>If either condition is not met, carefully lower the Vehicle back down to the ground and raise it again.</p>
Motor is not running.	<p>Check connection to power source; make sure it is plugged in and the appropriate voltage.</p> <p>Check wiring diagram on Power Unit.</p>
Hydraulic Fluid is dirty.	<p>Replace the dirty Hydraulic Fluid with clean, approved ATF fluids, such as Dexron III, Dexron VI, Mercon V, Mercon LV, or comparable.</p>
Lift makes weird noises.	<p>Lubricate hinge points using white lithium grease.</p>

If you continue to have issues with your Lift, take the Lift out of service, then contact your dealer or Danmar Support at [Danmar.com/support](http://Danmar.com/support) or by phone at **(877) 432-6627**.



**G**

<b>NOTICE</b>  Read operating and safety manuals before using lift.	<b>NOTICE</b>  Proper maintenance and inspection is necessary for safe operation.
<b>NOTICE</b>  Do not operate a damaged lift.	The messages and photographs shown are generic in nature and are meant to generally represent hazards common to all automotive lifts regardless of specific style. Funding for the development and validation of these labels was provided by the Automotive Lift Institute, PO Box 33116 Indiatrust, FL 32903. They are protected by copyright. Set of labels may be obtained from ALI or its member companies.

<b>CAUTION</b>  Lift to be used by trained operator only.	<b>CAUTION</b>  Authorized personnel only in lift area.
<b>CAUTION</b>  Use vehicle manufacturer's lift points.	<b>CAUTION</b>  Always use safety stands when removing or installing heavy components.
<b>CAUTION</b>  Use height extenders when necessary to ensure good contact.	<b>CAUTION</b>  Auxiliary adapters may reduce load capacity.
The messages and photographs shown are generic in nature and are meant to generally represent hazards common to all automotive lifts regardless of specific style. Funding for the development and validation of these labels was provided by the Automotive Lift Institute, PO Box 33116 Indiatrust, FL 32903. They are protected by copyright. Set of labels may be obtained from ALI or its member companies.	

<b>WARNING</b>  Clear area if vehicle is in danger of falling.	<b>WARNING</b>  Position vehicle with center of gravity midway between adapters.
<b>WARNING</b>  Remain clear of lift when raising or lowering vehicle.	<b>WARNING</b>  Avoid excessive rocking of vehicle while on lift.
<b>WARNING</b>  Do not override self-closing lift controls.	<b>WARNING</b>  Keep feet clear of lift while lowering.
The messages and photographs shown are generic in nature and are meant to generally represent hazards common to all automotive lifts regardless of specific style. Funding for the development and validation of these labels was provided by the Automotive Lift Institute, PO Box 33116 Indiatrust, FL 32903. They are protected by copyright. Set of labels may be obtained from ALI or its member companies.	

**H**

**PLEASE READ**  
Internal packing oil may cause the cylinders to bleed oil during start up. This is normal. To extend cylinder and seal life, raise the lift to full height at least once every day.

**K**

<b>DANMAR</b>		Santa Paula, CA USA www.danmar.com
MODEL NUMBER		
DESCRIPTION		
LIFT CAPACITY		DATE CODE
<b>VOLTAGE</b>		<b>SERIAL NUMBER</b>
<input type="checkbox"/> 110-220V, 50-60 Hz, 1 Ph <input type="checkbox"/> 208-240V, 50-60 Hz, 1 Ph <input type="checkbox"/> 380-415V, 50-60 Hz, 3 Ph <input type="checkbox"/> 208-440V, 50-60 Hz, 3 Ph		UPC
<b>⚡ DANGER!</b> Disconnect Power Before Servicing		<b>CE EAC</b>
WARRANTY VOID IF DATA PLATE IS REMOVED		MADE IN CHINA PN 5905703

**I**

**CERTIFIED AUTOMOTIVE LIFT**

**ALI CERTIFIED**  
To the provisions of ANSI/ALI ALCVT-2017 SAFETY REQUIREMENTS FOR CONSTRUCTION, TESTING AND VALIDATION

Automotive Lift Institute, Inc. | Cortland, NY 13045

**MET LISTED**  
Conforms to ANSI/UL 201 SAFETY STANDARD FOR GARAGE EQUIPMENT

**CERTIFIED TO CAN/CSA C22.2 NO.68**  
MOTOR OPERATED APPLIANCES (HOUSEHOLD & COMMERCIAL)

MET Laboratories, Inc. | BALTIMORE, MD 21230

Certification Label Serial Number  
AL00617000M

**L**

<b>TO RAISE LIFT:</b> 1. Press and hold <b>UP</b> button. 2. When lift is just <b>PAST</b> desired height, release <b>UP</b> button. 3. Hold down Lowering Handle. <b>DO NOT</b> hold down Safety Lock Release Handle. Lift engages on safety locks. 4. Release Lowering Handle.	<b>TO LOWER LIFT:</b> 1. Press and hold <b>UP</b> button for two to three seconds, moving lift off safety locks. 2. Hold down Safety Lock Release Handle <b>and</b> Lowering Handle. 3. When lift is fully lowered, release both handles.
---	--

PN 5905414

**J**

**NOTICE**

If attachments, accessories, or configuration modifying components used on this lift are located in the load path and affect operation of the lift, affect the lift electrical listing, or affect intended vehicle accommodation; and if they are not certified for use on this lift, then the certification of this lift shall become null and void. Contact the participant for information pertaining to certified attachments, accessories, or configuration modifying components.

**FRONT OF  
POWERSIDE POST**

**ADJACENT TO PU  
POWERSIDE POST**

**BACK OF  
POWERSIDE POST**

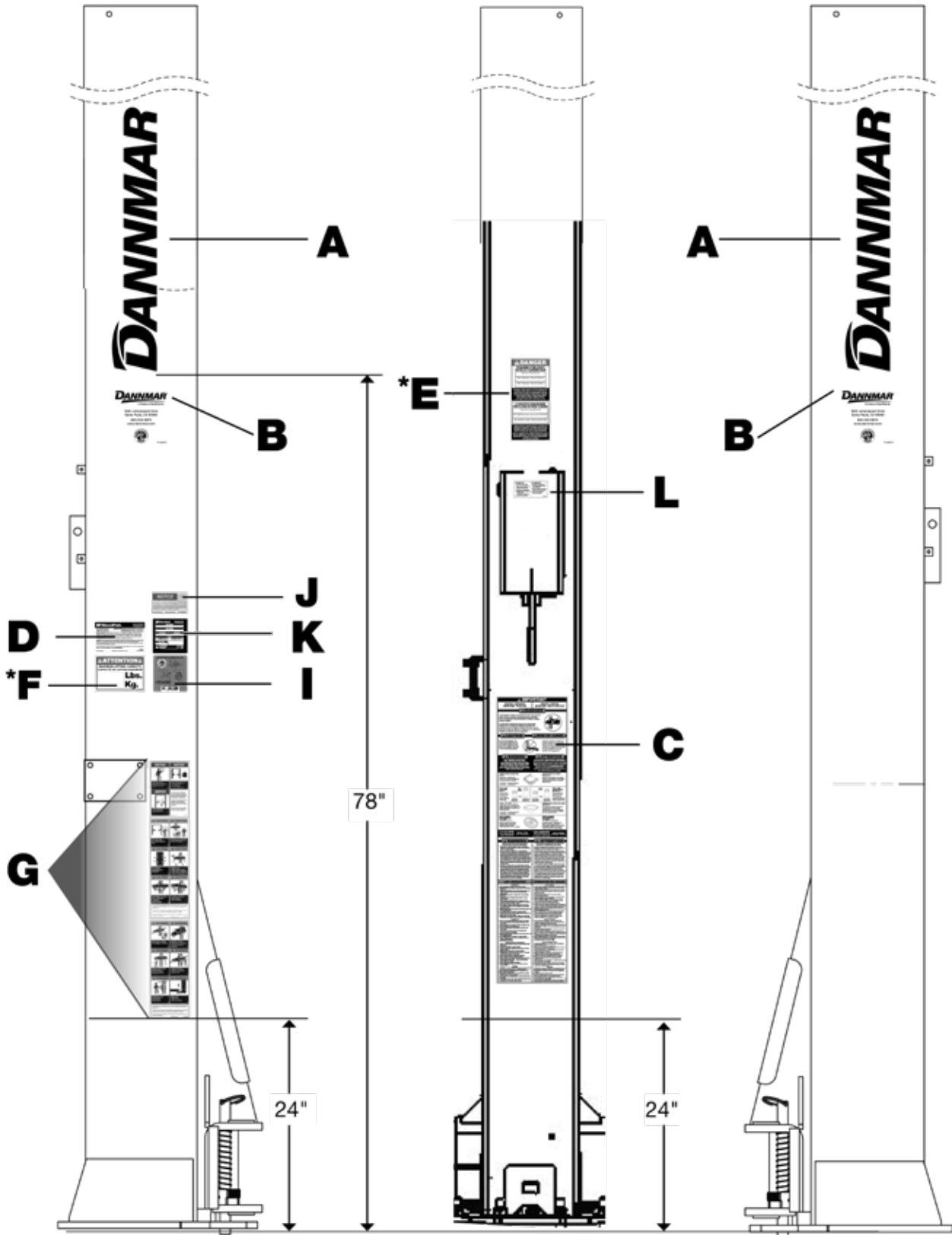



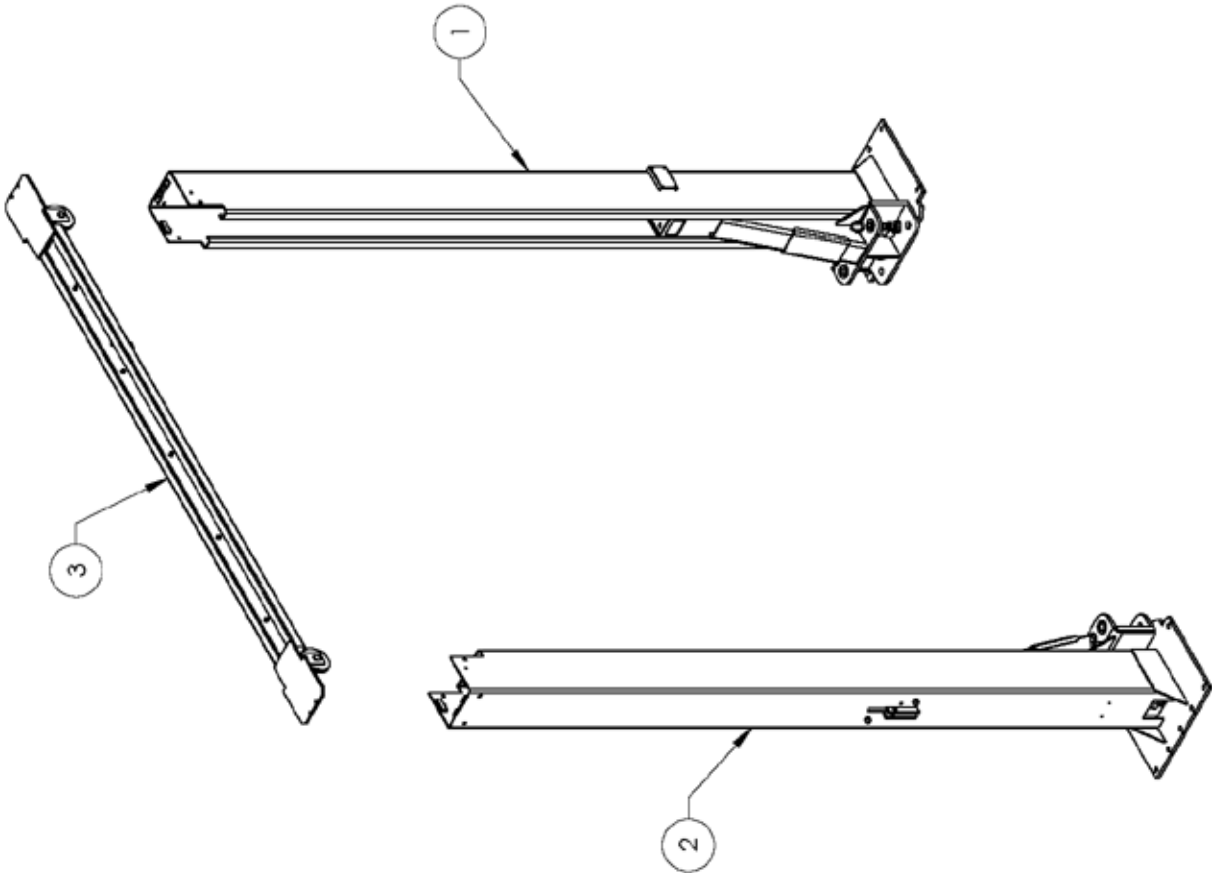

ITEM NO	PART NUMBER	DESCRIPTION	QTY	REV
1	5215982	D2-12C POWER SIDE POST ASSEMBLY	1	A
2	5215981	D2-12C OFF SIDE POST ASSEMBLY	1	A
3	5210244	D2-12/15C TOP TROUGH ASSEMBLY	1	A

DO NOT SCALE DRAWING	NAME	DATE	 <b>BP BendPak</b> 1645 LEMCINWOOD DR. SANTA PAULA, CA 93060
	DRAWN	TIM	
	CHECKED	OR	8/27/2020
	THIRD ANGLE PROJECTION		TITLE
			D2-12C LIFT SUPERSTRUCTURE
			SEE DWG. NO.
	DIMENSIONS ARE IN MM		A
	PROPRIETARY AND CONFIDENTIAL THE INFORMATION CONTAINED HEREIN IS THE SOLE PROPERTY OF BENDPAK INC. REPRODUCTION IN WHOLE OR IN PART WITHOUT THE WRITTEN PERMISSION OF BENDPAK INC. IS PROHIBITED.		REV
	SCALE: 1:35		5245103
	SHEET 1 OF 1		A

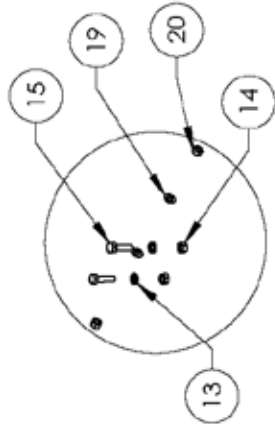

DETAIL A  
SCALE 1:12

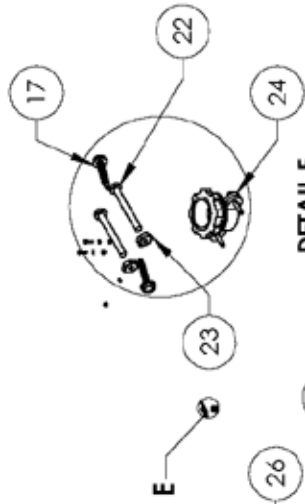

DETAIL E  
SCALE 1:4

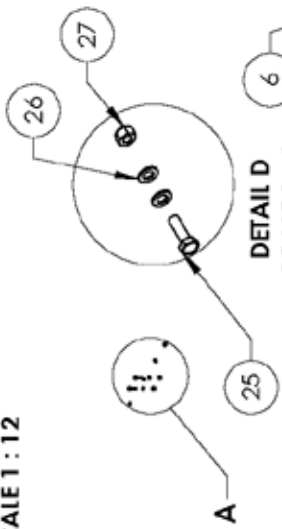

DETAIL D  
SCALE 1:4

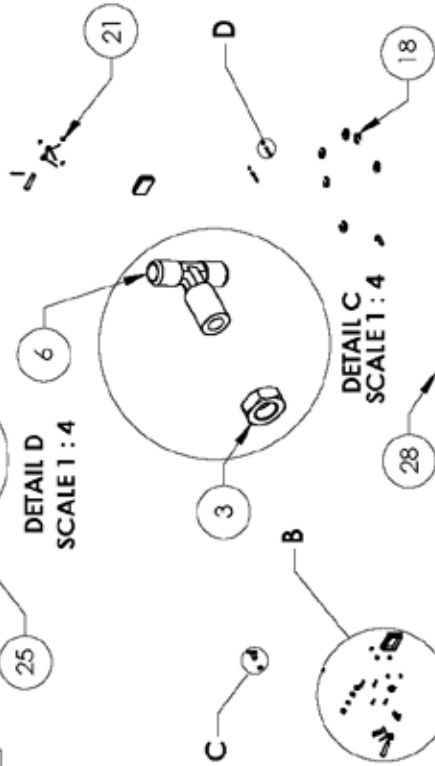

DETAIL C  
SCALE 1:4

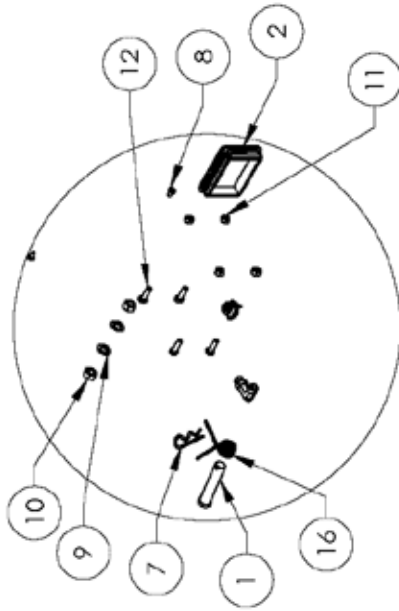

DETAIL B  
SCALE 1:12

ITEM NO	PART NUMBER	DESCRIPTION	QTY	REV
1	5509001	D27GP-7 XPR SERIES SAFETY CLEVIS PIN	2	B
2	5715194	D27XPR POLYURETHANE COVER BLOCK 105 X 80	2	D
3	5530025	NUT M10 X 1.5 NI	2	-
4	5530026	FIG ELB-04 NPT 1/4-04 JIC	2	-
5	5530033	FIG ELB-06 JIC-064 ORH	1	-
6	5530033	FIG TEE-04 JIC-04 JIC-06 JIC	2	-
7	5530030	MODEL P21 HAIR PIN/LARGE	2	-
8	5530026	PHPS M8 X 1.0	4	-
9	5545347	WASHER M12 FLAT WASHER	2	-
10	5530034	NUT M12 X 1.75	2	-
11	5530001	NUT M8 X 1.25 NI	4	-
12	5530010	HHB M8 X 1.25 X 25	4	-
13	5545200	WASHER M10 X 0.18 SL	4	-
14	5530030	NUT M10 X 1.5	4	-
15	5530060	HHB M10 X 1.5 X 38	4	-
16	5540075	R.H. 2.5 WIRE DIA. 0.205 X 7.5 LG	4	B
17	5530099	C WASHER SHIM FOR TIETS	2	-
18	5545341	WASHER M10 X 0.20 FLAT	4	-
19	5530031	NUT M10 X 1.5 NI	4	-
20	5530031	ROTOR CLIP 1/2" ID 3/8 SS	2	-
21	5530115	BHS 6-32 X 1.25	2	-
22	5530150	HN 6-62	2	-
23	5530140	ROMEX CONNECTOR 3/8 #6623	2	-
24	5530099	HHB M6 WASHER	4	-
25	5545303	M6 FLAT WASHER	8	-
26	5530037	NUT M6 X 1.0 NI	4	-
27	5530037	LIQUID PTFE THREAD SEALANT 50ml	4	-

DO NOT SCALE DRAWING

DRAWN		TM	02/11/2010
CHECKED		OR	4/17/2020
THIRD ANGLE PROJECTION			
<p><b>PROPRIETARY AND CONFIDENTIAL</b>          THE INFORMATION CONTAINED IN THIS DRAWING IS          THE PROPERTY OF BENDPAK INC. AND IS TO BE USED          ONLY FOR THE PROJECT AND QUANTITY SPECIFIED.          ANY REPRODUCTION IN ANY FORM WITHOUT          THE WRITTEN PERMISSION OF BENDPAK INC. IS          PROHIBITED.</p>			
DIMENSIONS ARE IN MM			
<p><b>BendPak</b>          1645 LEMMONWOOD DR          SANTA PAULA, CA 93060</p>		<p><b>D2-12/15, XPR</b>  <b>CLEARFLOOR PARTS BAG</b></p>	
SIZE DWG. NO.	A	5174518	REV M
SCALE:	1:30		SHEET 1 OF 1

**BP BendPak.**  
 1645 LEMONWOOD DR.  
 SANTA PAULA, CA 93360

TITLE		D2-12C PARTS BOX	
SIZE	DWG. NO.	REV	
A	5250314	A	
SCALE: 1:22		SHEET 2 OF 2	





ITEM NO	PART NUMBER	DESCRIPTION	QTY	REV
1	5174518	D2-12/15, XPR CLEARFLOOR PARTS BAG	1	M
2	5736605	D2-12C/XPR-12 BOLT ON ARM RESTRAINT GEAR	4	E
3	5746192	ARM ADAPTER, MEDIUM	4	D
4	5746193	ARM ADAPTER, LONG	4	C
5	5716174	D2-12/15/GP/XPR OFF SIDE PLASTIC SAFETY COVER	1	B
6	5716173	D2-12/15/GP/XPR POWER SIDE PLASTIC SAFETY COVER	1	B
7	5215701	ROUND LIFT PAD ADAPTER ASSEMBLY	4	D
8	5715003	POWER UNIT VIBRATION DAMPENER	1	B
9	5210010	D2/XPR OFF SIDE SAFETY WELDMENT	1	F
10	5210196	D2/XPR POWER SIDE INCLINED SAFETY ASSEMBLY	1	C
11	5505346	D2/XPR-12C/FD LIFT HEAD PIN WELDMENT	4	B
12	5570150	HYDRAULIC HOSE ASSEMBLY Ø6.35 x 9611mm, SB	1	E
13	5570017	HYDRAULIC HOSE ASSEMBLY Ø10 x 1219mm, SB	1	D
14	5570832	HYDRAULIC HOSE ASSEMBLY Ø6.35 x 2299mm, SB	1	F
15	5595125	Ø2.4mm x 8900 SAFETY CABLE	1	C
16	5595922	CABLE ASSEMBLY Ø12 x 10640mm, ST	2	D
17	5540281	C RING Ø38mm OD 5103-1.50	4	-
18	5746166	DOUBLE THREADED ROD M10 x 1.5 x 295	2	B
19	5525150	SPDT MICRO SWITCH;25A@125VAC	1	-
20	5520116	14-4 SJO UL 62 CABLE 300VDC	427.5mm*	-
21	5525112	MICRO SWITCH COVER-3FA2	1	-
22	5716634	D2/10AP/XPR MICROSWITCH COVER, PLASTIC	1	B
23	5215702	CRADLE LIFT PAD LARGE ADAPTER ASSEMBLY	4	E
24	5530308	AB 3/4" x 7"	14	-
25	5550112	FIG NPI -04 NPT x-04 F NPT	2	-
26	5900252	D2-12/15 INSTALLATION MANUAL	1	-
27	5701660	10PA/D2-12/15/XPR HEIGHT ADAPTER HOLDER	2	A
28	5701661	D2/XPR-12/15/18 FOOT GUARD, R.H.	2	A
29	5701662	D2/XPR-12/15/18 FOOT GUARD, L.H.	2	A

DO NOT SCALE DRAWING

NAME	DATE
TA	08/04/2020
OR	8/27/2020

TITLE: D2-12C PARTS BOX

SEE DWG. NO. A 5250314 REV A

SCALE: 1:28 SHEET 1 OF 2

BP BendPak.  
1645 LEMONWOOD DR.  
SANTA PAULA, CA 93060

THIRD ANGLE PROJECTION

PROPRIETARY AND CONFIDENTIAL  
THE INFORMATION CONTAINED IN THIS DRAWING IS THE SOLE PROPERTY OF BENDPAK INC. ANY REPRODUCTION OR TRANSMISSION IN ANY FORM OR BY ANY MEANS WITHOUT THE WRITTEN PERMISSION OF BENDPAK INC. IS PROHIBITED.

DIMENSIONS ARE IN (MM)

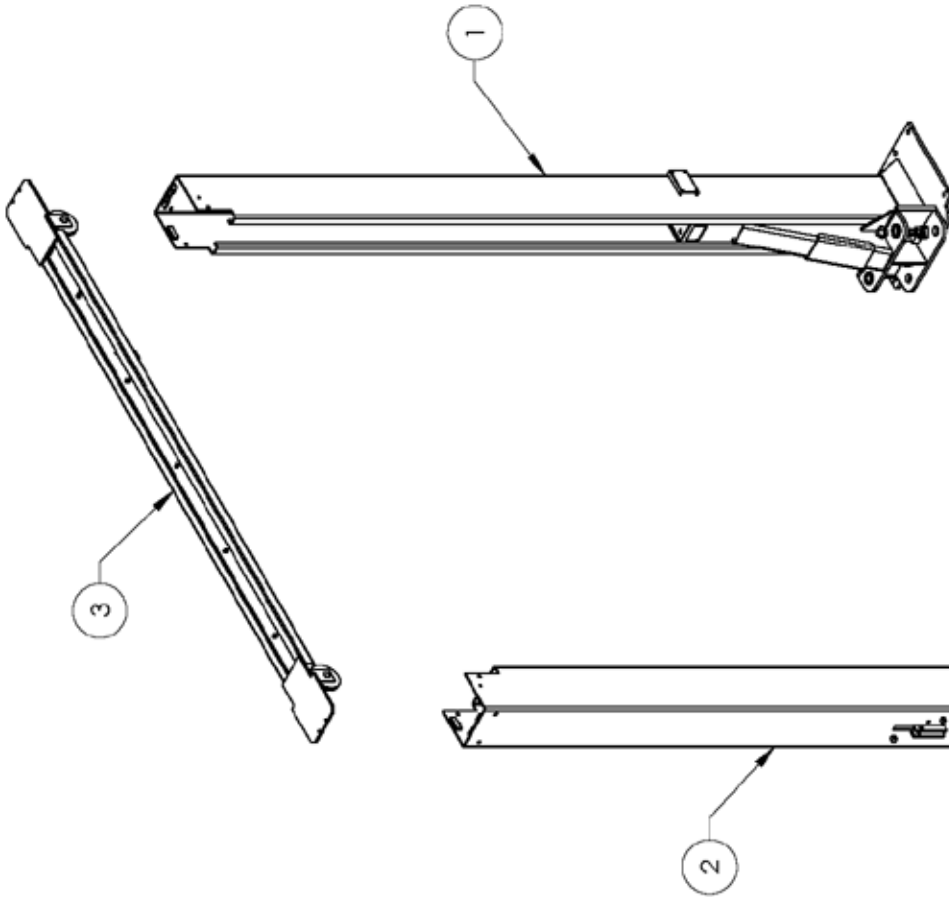

ITEM NO	PART NUMBER	DESCRIPTION	QTY	REV
1	5215979	D2-15C POWER SIDE POST ASSEMBLY	1	A
2	5215978	D2-15C OFF SIDE POST ASSEMBLY	1	A
3	5210244	D2-12/15C TOP TROUGH ASSEMBLY	1	A

DO NOT SCALE DRAWING		NAME	DATE
DIMENSIONS ARE IN INCH		TIM	08/04/2020
		CHECKED	OR
		8/27/2020	
		THIRD ANGLE PROJECTION	
		<small>PROPRIETARY AND CONFIDENTIAL          THIS DRAWING IS THE PROPERTY OF BENDPAK, INC. ANY          REPRODUCTION OR TRANSMISSION WITHOUT          THE WRITTEN PERMISSION OF BENDPAK, INC. IS          PROHIBITED.</small>	
		1645 LEMONWOOD DR. SANTA PAULA, CA 95060	
TITLE:		D2-15C LIFT SUPERSTRUCTURE	
SIZE DWG. NO.		A 5245104	
REV		A	
SCALE: 1:35		SHEET 1 OF 1	



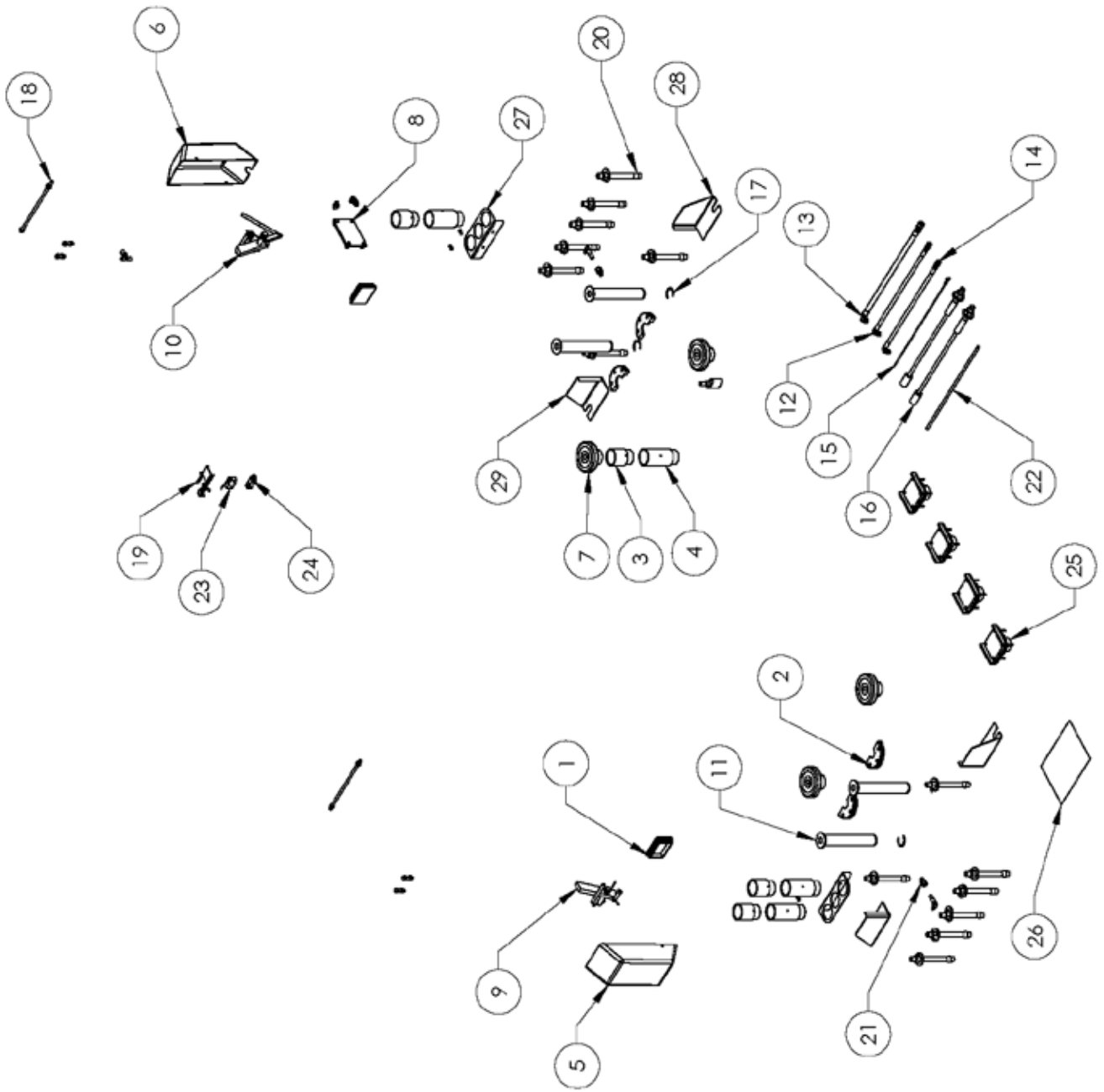

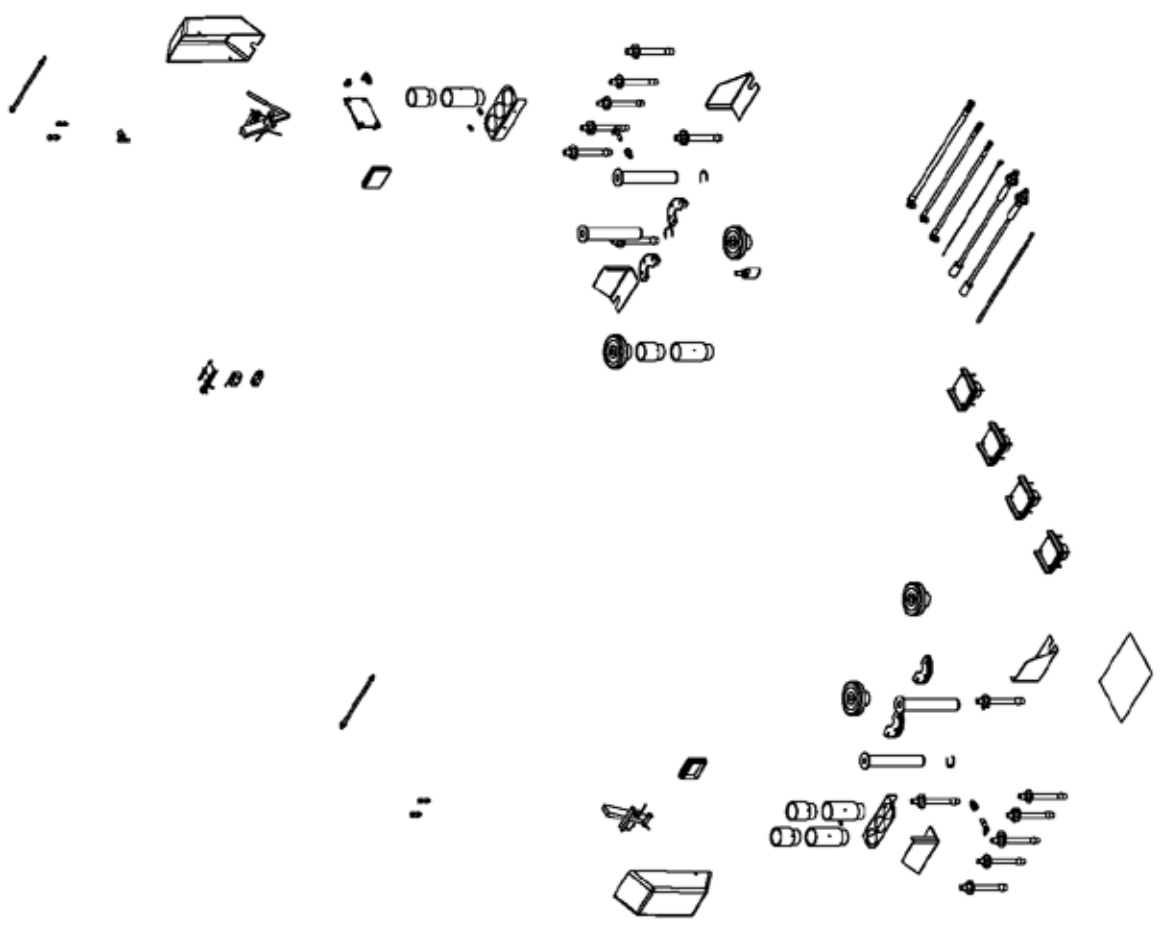
12.00

ITEM NO	PART NUMBER	DESCRIPTION	QTY	REV
1	5174518	D2-12/15 XPR CLEARFLOOR PARTS BAG	1	M
2	5736606	D2/XPR-15/18 BOLT ON ARM RESTRAINT GEAR	4	F
3	5746192	ARM ADAPTER, MEDIUM	4	D
4	5746193	ARM ADAPTER, LONG	4	C
5	5716174	D2-12/15/GP/XPR OFF SIDE PLASTIC SAFETY COVER	1	B
6	5716173	D2-12/15/GP/XPR POWERSIDE PLASTIC SAFETY COVER	1	B
7	5215701	ROUND LIFT PAD ADAPTER ASSEMBLY	4	D
8	5715003	POWER UNIT VIBRATION DAMPENER	1	B
9	5210010	D2/XPR OFF SIDE SAFETY WELDMENT	1	F
10	5210196	D2/XPR POWER SIDE INCLINED SAFETY ASSEMBLY	1	C
11	5600349	D2/XPR-15/18C LIFT HEAD PIN WELDMENT	4	C
12	5570150	HYDRAULIC HOSE ASSEMBLY Ø6.35 x 9611mm SB	1	E
13	5570017	HYDRAULIC HOSE ASSEMBLY Ø10 x 1219mm SB	1	D
14	5570832	HYDRAULIC HOSE ASSEMBLY Ø6.35 x 2299mm SB	1	F
15	5595125	Ø2.4mm x 8900 SAFETY CABLE	1	C
16	5595922	CABLE ASSEMBLY Ø12 x 10640mm ST	2	D
17	5540112	SNAP RING; TRUARC 5103-175	4	-
18	5746166	DOUBLE THREADED ROD M10 x 1.5 x 295	2	B
19	5716634	D2/10AP/XPR MICROSWITCH COVER, PLASTIC	1	B
20	5530308	AB 3/4" x 7"	14	-
21	5550112	FIG NPT -04 NPT x -04 F NPT	2	-
22	5520116	14-4 SJO UL 62 CABLE 300vac	4275mm*	-
23	5525150	SPDT MICRO SWITCH;25A@125VAC	1	-
24	5525112	MICRO SWITCH COVER-5PA2	1	-
25	5215702	GRADLE LIFT PAD LARGE ADAPTER ASSEMBLY	4	E
26	5900249	D2-10 INSTALLATION MANUAL	1	-
27	5701660	10P A/D2-12/15/XPR HEIGHT ADAPTER HOLDER	2	A
28	5701661	D2/XPR-12/15/18 FOOT GUARD, R.H.	2	A
29	5701662	D2/XPR-12/15/18 FOOT GUARD, L.H.	2	A

DO NOT SCALE DRAWING

NAME DATE

DRAWN TM 09/04/2020

CHECKED OR 8/27/2020

THIRD ANGLE PROJECTION

TITLE: D2-15C PARTS BOX

SEE DWG. NO. 5250315

REV A

SCALE: 1:28

SHEET 1 OF 2

**BP BendPak.**  
1645 LEMONWOOD DR.  
SANTA PAULA, CA 90060

PROPRIETARY AND CONFIDENTIAL  
THIS DOCUMENT IS THE SOLE PROPERTY OF BENDPAK INC. ANY  
REPRODUCTION IN WHOLE OR IN PART WITHOUT  
THE WRITTEN PERMISSION OF BENDPAK INC. IS  
FORBIDDEN.

DIMENSIONS ARE IN MM

***DANNMAR***<sup>®</sup>

---

1645 Lemonwood Dr. • Santa Paula, CA, 93060 USA  
Toll Free: (877) 432-6627

**FOR PARTS OR TECHNICAL SUPPORT:**  
1 (877) 437-6627