

CH50 - CH480

Service Book KH001801G



Customers. The core of our innovation









ENGLISH

CONTENTS

1. GENERAL INFORMATION	5 - G
2. SAFETY	5 - G
2.1. GENERAL INFORMATION	5 - G
2.2. GENERAL PRECAUTIONS	6 - G
2.2.1. Liquids to cool	6 - G
2.2.2. Precautions for lifting and transport	6 - G
2.2.3. Precautions to be observed during installation	7 - G
2.2.4. Precautions during operation	7 - G
2.2.5. Precautions for maintenance and repair work	7 - G
2.3. IDENTIFICATION PLATE	8 - G
2.4. SAFETY DEVICES	9 - G
3. TECHNICAL DATA	10 - G
3.1. REFRIGERANT R22	10 - G
3.2. REFRIGERANT R407C	11 - G
4. GENERAL DESCRIPTION OF THE MACHINE	12 - G
4.1. TECHNICAL SPACES, WEIGHTS	12 - G
4.2. OPERATION	13 - G
4.2.1. Hydraulic circuit	13 - G
4.2.2. Chiller circuit	13 - G
4.3. CONTROL PANEL	15 - G
5. DUCTING FOR HOT AIR LEAVING FANS	16 - G
5.1. EXAMPLES OF SIZING EXPULSION DUCTS	18 - G
6. CONTROL THERMOSTAT	19 - G
6.1. CHARACTERISTICS	19 - G
6.2. USING THE KEYS AND READING THE DISPLAY	19 - G
6.3. MOST COMMON PROCEDURES	21 - G
6.4. CONFIGURATION DIAGRAM	21 - G
6.5. MAIN FUNCTIONS	22 - G
7. INSTALLATION	22 - G
7.1. REQUISITES OF THE ROOM - POSITIONING	22 - G
7.2. REFRIGERATED WATER DISTRIBUTION NETWORK	23 - G
7.2.1. Head of the pump on the machine and head at the service	23 - G
7.2.2. Ratio between pipe lengths and diameters	24 - G
7.2.3. Hydraulic circuit pre-charging	25 - G
7.3. MACHINE CONNECTIONS TO THE REFRIGERATED LIQUID DISTRIBUTION NETWORK ..	25 - G
7.4. ELECTRICAL CONNECTIONS	26 - G
7.5. FILLING WITH WATER	27 - G
7.6. BLEEDING AIR FROM HYDRAULIC CIRCUIT (SERVICES)	28 - G



7.7. ANTI-FREEZE PROTECTION	29 - G
8. START-UP	29 - G
8.1. PRELIMINARY CHECKS	29 - G
9. SWITCHING OFF THE CHILLER	30 - G
10. SERVICING THE CHILLER	31 - G
10.1. GENERAL INFORMATION	31 - G
10.2. SCHEDULED MAINTENANCE	32 - G
10.3. UNSCHEDULED MAINTENANCE	32 - G
11. PUTTING THE MACHINE OUT OF SERVICE	33 - G
12. SPARE PARTS	33 - G
13. ACCESSORIES	34 - G
13.1. FILTERS	34 - G
13.2. HOT GAS INJECTION BY-PASS VALVE	34 - G
13.3. CHECKING PHASE SEQUENCE AND VOLTAGE	35 - G

	<p>Refers to procedures or practices that, if not performed correctly, <i>will cause</i> serious damage to health, injury or death.</p>
	<p>Refers to procedures or practices that, if not performed correctly, <i>may cause</i> serious damage to health, injury or death.</p>
	<p>Refers to procedures or practices that, if not performed correctly, <i>may cause</i> damage to the product.</p>
	<p>Danger: electric discharge.</p>
	<p>Danger: hot surface.</p>
	<p>Protective footwear must be worn.</p>
	<p>Protective gloves must be worn.</p>
	<p>Face guard must be used.</p>
	<p>Respiratory protection must be used.</p>

Tab.1

The symbols have been taken from EEC Directive 77/576.

1. GENERAL INFORMATION

The machines described in this manual will hereinafter be called “WATER CHILLER” or simply “CHILLER”.

This manual is for the personnel assigned to installing, using and servicing the chiller.

These chillers have been designed to cool a flow of liquid.

In most applications the liquid to cool is water; for this reason the word “WATER” will hereinafter be used even if the liquid to cool is not water (for instance, a mixture of water and ethylene glycol).

The liquid to cool must be compatible with the materials used: this analysis must always be made prior to purchasing or installing the chiller (See “WATER SPECIFICATIONS SHEET” on page 38)

When interfacing with other machinery, keep strictly to the instructions given by the manufacturers of the other machines.

2. SAFETY

2.1. GENERAL INFORMATION

This machine has been designed to be safe for its designated use provided it has been installed, commissioned and serviced following the instructions given in this manual.

Therefore it must be studied by anyone wishing to install, use or service the system.

The machine contains electric components that operate at line voltage and also moving parts such as the fan and/or pump.

Therefore it must normally be cut off from the electricity supply before being opened.

Any maintenance work that requires access to the system must be performed by skilled or suitably trained personnel who are fully aware of the necessary precautions.

When handling or servicing the machine and auxiliary equipment, personnel must work in safety and observe the instructions concerning safety and health at the place of installation.

Many accidents that occur when operating and servicing the machinery are the result of failing to observe basic safety precautions or rules.

Accidents can often be avoided by recognizing a situation that is potentially hazardous.

The user has to make sure that all personnel concerned with operating and servicing the machine and auxiliary equipment have **read and understood** all the warnings, precautions, prohibitions and notes given in this manual and on the machine.

Improper use or maintenance of the machine and auxiliary equipment can be hazardous and cause even fatal accidents.

Never operate the machine or auxiliary equipment until the instructions on starting and operation have clearly been read and understood by the personnel involved.

Never perform any maintenance work or repairs until the instructions given in this manual have clearly been understood by the personnel involved.

It is not possible to foresee all the possible circumstances that may be a potential hazard for people. The notes on safety in this manual are therefore not exhaustive.

If the user employs operating procedures, instruments or work methods that are not specifically recommended, he must make sure that the machine and auxiliary equipment do not get damaged or made unsafe, and that there are no risks for people and property.

The water chillers made by PIOVAN must not be installed in potentially explosive atmospheres (they are not explosion proof).

2.2. GENERAL PRECAUTIONS

2.2.1. Liquids to cool

The liquids to cool must be compatible with the materials used (See “WATER SPECIFICATIONS SHEET” on page 38). They may, for instance, be **water or mixtures of water and ethylene glycol**.

Never use distilled or demineralized water as it is incompatible with the construction materials of the chiller.

It is recommended to add anti-corrosive chemical additives to the water that are compatible with the materials used and work with pH between 7 and 8.

In the case of glycol mixtures, too, it is extremely important to use appropriate chemical additives (contact the glycol supplier) to protect the materials of the chiller from any corrosive action caused by the chemical deterioration to which glycol is subject.

Using these chemical additives **is necessary** when the chiller belongs to **a hydraulic circuit that is open to the atmosphere in at least one point**: in this case, the constant supply of oxygen will feed any corrosive reactions inside the chiller.

The liquids to cool must be not flammable. If the liquids to cool contain hazardous substances (such as, for instance, ethylene glycol), any liquid spilling out of an area of leakage must be collected as it can damage the environment.

In addition, when the chiller will no longer be used, it will be necessary to dispose of the hazardous liquids by consigning them to specialized firms authorized to treat them.

2.2.2. Precautions for lifting and transport

The machine must be handled by expert personnel in accordance with binding safety and health regulations. Check the state of the machine after removing the packing. If you have any doubts, do not use the machine and contact the PIOVAN Technical Service Department.

The packaging must be disposed of in accordance with binding waste disposal regulations.

Avoid all hazardous situations when using a hoist to lift heavy items.

When a load is lifted off the ground, it is necessary to keep away from the area beneath and around it.

Keep the lifting speed and acceleration within safe limits and never leave a load hanging from a hoist any longer than necessary.

Handling chillers with lift forks must be done **in accordance with the enclosed diagrams and figures**.

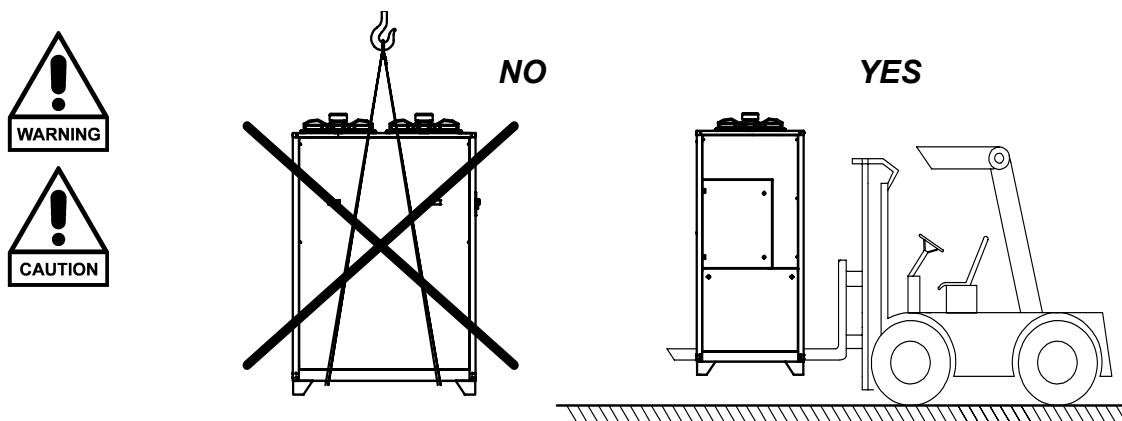

Fig. 1

2.2.3. Precautions to be observed during installation

The machine must be installed by expert personnel in accordance with binding safety and health regulations. For the connection to the electricity supply, check that the voltage and frequency stated on the machine data plate correspond to those of the electricity mains and check that the mains circuit is suitably scaled for the machine maximum power (Tab. 2 page 10).

2.2.4. Precautions during operation

Machine operation must be followed by skilled personnel directed by a qualified supervisor.

All the water pipes must be painted or clearly marked in accordance with local safety regulations at the place of installation.

Do not remove or tamper with the safety devices, guards or insulating materials installed on the machine or auxiliary equipment.

All the electrical connections must conform to the regulations at the place of installation.

The machine and auxiliary equipment must be earthed and protected against short-circuits, overloads and insulation failures (residual current switch).

When the main switch is turned off the voltage in the electric circuit reaches fatal levels; therefore, if it is necessary to work on the electric circuit, the greatest precautions must be taken.

Never open the panels closing off the electrical equipment while it is live unless this is necessary for testing, measurements or settings that are anyhow to be made by skilled personnel equipped for the purpose.

This work should be performed solely by qualified personnel with suitable equipment and wearing protection against dangers of an electrical nature.

2.2.5. Precautions for maintenance and repair work

Maintenance, overhauling and repairing the machine must be performed by **skilled personnel directed by a qualified supervisor**.

Tab. 15 page 32 for the machine's routine maintenance.

When it is necessary to discharge waste materials, make sure no water courses are polluted and no materials are burnt that may pollute the air.

Use solely appropriate storage methods that are environment friendly.

If spare parts are needed, use genuine parts only.

Keep a written report of all the work done on the machine and auxiliary equipment; use the attached sheet for this purpose.

The frequency and nature of the work required in a certain period may reveal abnormal operating conditions that should be corrected.

Use solely the refrigerant gas specified on the machine's data plate; never substitute or mix gases as they are not alternatives.

Make sure that all the instructions concerning operation and maintenance are closely followed and that the entire unit with all its accessories and safety devices is serviced in good working order.

The accuracy of the temperature and pressure gauges has to be checked regularly. They need to be replaced when the acceptable tolerances are exceeded.

Always keep the machine clean. Protect the components and exposed openings by covering them for example with clean rags during maintenance work and repairs.

Never weld or perform any other operations that generate heat near a system containing oil or flammable liquids.

Systems that may contain oil or flammable liquids must be completely drained off and cleaned, for example with steam, before performing these operations. Never weld on, or anyhow modify, a container that can be pressurized.

To prevent an increase in working pressure and temperature, check and clean the heat exchange surfaces (e.g., the condenser fins) regularly. Set down a suitable frequency for cleaning each unit. Tab. 15 page 32 for the machine's routine maintenance.

Avoid damaging the safety valves and other pressure limiting devices.

Avoid obstructing these parts with paint, oil or accumulated dirt.

Precautions need to be taken when welding or performing repair work generating heat, flames or sparks. The components nearby need to be protected with non-flammable material and if the work needs to be done near parts of the lubrication system or near components that may contain oil or flammable liquids, the system must first be bled.

Never use a source of light such as a naked flame to inspect parts of a machine.

Before dismantling machine parts, make sure all the movable and heavy parts have been secured.

When repairs have been completed, make sure no tools, loose parts or rags have been left inside the machine.

Check the direction of rotation of the motors when starting the machine for the first time after work on the electrical connections or on the supply disconnecting device.

All the guards have to be re-installed after maintenance or repair work.

Never use flammable liquids to clean components when the machine is running. If non-flammable hydrocarbons containing chlorine are used for cleaning, all the safety precautions must be taken against the toxic fumes that may be given off.

Before removing any panels or any part of the unit, perform the following operations:

Cut off the machine from the main electricity supply from above the supply cable.

Lock the disconnecting switch in the "OFF" position with a padlock.

Put a sign up on the disconnecting switch warning "WORK IN PROGRESS - DO NOT POWER UP".

Do not turn on the electricity supply switch or try to start the machine if there is a warning sign attached.

The manufacturer cannot be considered liable for any damage to people or property caused by the failure to observe the above-mentioned safety regulations. These rules supplement but do not replace the binding industrial accident prevention regulations in the country where the machine is installed.

The chillers are charged with R407c or R22. Refer to the identification plate on the back panel of the machine.

To clean a heavily contaminated chiller circuit, for instance after the burning of the compressor , it is necessary for the work to be done by an expert chiller technician.

Cylinders containing refrigerant gases must be used and stored in accordance with the recommendations of the manufacturers of these cylinders and with the binding safety laws and regulations at the place of installation.

The machine can arrive at its destination packed in palletizable cardboard packing, crates, cages, wooden pallets and protective plastic sheets. Keep the packing materials to protect the machine if it has to be moved again in the future; in any case, dispose of such materials observing the binding provisions in the place of installation.

2.3. IDENTIFICATION PLATE

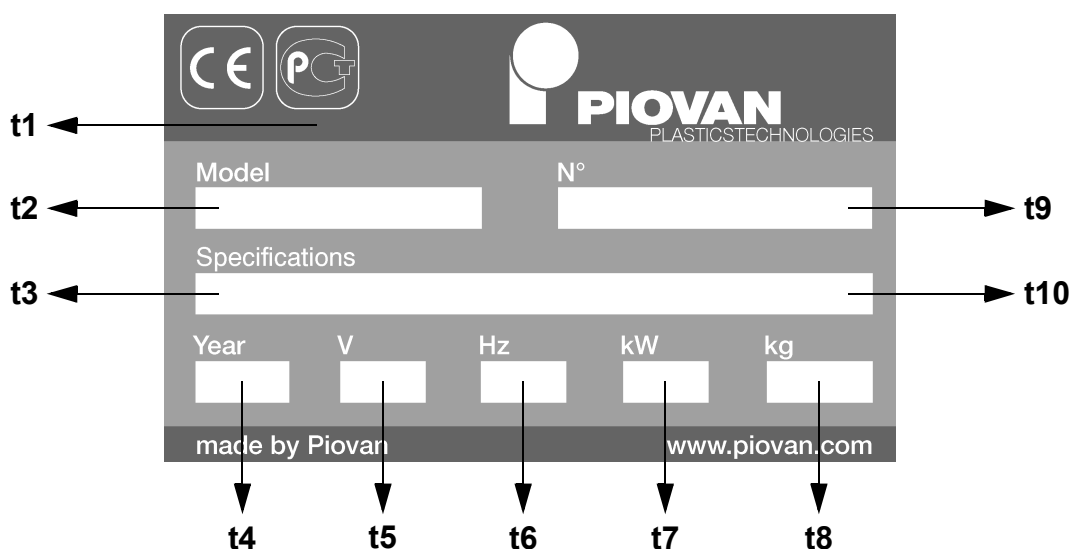

Fig. 2

REFERENCE	DESCRIPTION
t1	NOTIFIED BODY (Dir. 97/23/CEE)
t2	MODEL
t3	TYPE / QUANTITY OF REFRIGERANT GAS
t4	YEAR OF MANUFACTURE
t5	POWER SUPPLY VOLTAGE
t6	POWER SUPPLY FREQUENCY
t7	POWER
t8	WEIGHT
t9	SERIAL NUMBER
t10	MAXIMUM PRESSURES

2.4. SAFETY DEVICES

The water chillers are equipped with the following safety devices:

- **SP2**, high pressure switch, which have been adjusted to 26 bar; it is forbidden to modify the setting value.
- **QM1 - QM2 - QM6**, motor circuit breakers which have been adjusted according to the maximum current rating of each protected motor: it is forbidden to modify the setting value.

QM3 , Compressor circuit breakers, which have been adjusted according to the maximum current rating shown in the electric drawing. It is forbidden to modify the setting value.

3. TECHNICAL DATA

3.1. REFRIGERANT R22

MAIN TECHNICAL DATA		CH50		CH90		
Three-phase voltage (V)	±10%	400	460	400	460	
Frequency (Hz)	±1%	50	60	50	60	
Place of installation	indoor					
Cooling capacity (KW) (*)	7.00		10.51			
Total power installed (standard pump) (kW) (**)	4.1	4.6	4.9	5.7		
Total power installed (uprated pump) (kW) (**)	6.6	6.3	7.4	7.4		
Maximum noise level (dBA)	≤80					
Type of refrigerant	R22					
Refrigerant charge (kg)	4.5		5			
Type of compressor fluid	Suniso 3GS		Suniso 3GS			
MAIN TECHNICAL DATA		CH180		CH280		
Three-phase voltage (V)	±10%	400	460	400	380	
Frequency (Hz)	±1%	50	60	50	60	
Place of installation	indoor					
Cooling capacity (KW) (*)	22.70		37.80			
Total power installed (standard pump) (kW) (**)	9.2	8.8	13.4	14.4	14.4	
Total power installed (uprated pump) (kW) (**)	10.6	10.5	16.7	17.4	17.4	
Maximum noise level (dBA)	≤80					
Type of refrigerant	R22					
Refrigerant charge (kg)	5		7			
Type of compressor fluid	Suniso 3GS		Suniso 3GS			
MAIN TECHNICAL DATA		CH380			CH480	
Three-phase voltage (V)	±10%	400	380	460	400	380
Frequency (Hz)	±1%	50	60	60	50	60
Place of installation	indoor					
Cooling capacity (KW) (*)	47.70			56.40		
Total power installed (standard pump) (kW) (**)	17.2	17.1	17.5	20.9	20.1	20.6
Total power installed (uprated pump) (kW) (**)	19.8	20.1	20.5	23	22.9	23.3
Maximum noise level (dBA)	≤80					
Type of refrigerant	R22					
Refrigerant charge (kg)	7			9		
Type of compressor fluid	Suniso 3GS			Suniso 3GS		
WORK ENVIRONMENT						
Ambient temperature (°C)	version for indoor installation (standard)			7 ÷ 40		
	version for outdoor application with fan speed regulation (special)			-10 ÷ 40		
Maximum altitude (m)	1500					
Transport and storage temperature (°C)	-10 ÷ 50					

Tab.2

(*) Measured in the following conditions: Ambient temperature = 25°C; Temperature of the water entering the chiller = 15°C;

Altitude 0 m; Refrigerated liquid: water without additives.

(**) See wiring diagram.

3.2. REFRIGERANT R407C

MAIN TECHNICAL DATA		CH50		CH90			
Three-phase voltage (V)	±10%	400	460	400	460		
Frequency (Hz)	±1%	50	60	50	60		
Place of installation	indoor						
Cooling capacity (KW) (*)	6.63		10.19				
Total power installed (standard pump) (kW) (**)	4.1	4.6	4.9	5.7			
Total power installed (uprated pump) (kW) (**)	6.6	6.3	7.4	7.4			
Maximum noise level (dBA)	≤80						
Type of refrigerant	R407C						
Refrigerant charge (kg)	4.5		5				
Type of compressor fluid	Mobil EAL ARCTIC 22CC		Mobil EAL ARCTIC 22CC				
MAIN TECHNICAL DATA		CH180		CH280			
Three-phase voltage (V)	±10%	400	460	400	380	460	
Frequency (Hz)	±1%	50	60	50	60	60	
Place of installation	indoor						
Cooling capacity (KW) (*)	21.91			37.5			
Total power installed (standard pump) (kW) (**)	9.2	8.8	13.4	14.4	14.4		
Total power installed (uprated pump) (kW) (**)	10.6	10.5	16.7	17.4	17.4		
Maximum noise level (dBA)	≤80						
Type of refrigerant	R407C						
Refrigerant charge (kg)	5			7			
Type of compressor fluid	Mobil EAL ARCTIC 22CC			Mobil EAL ARCTIC 22CC			
MAIN TECHNICAL DATA		CH380			CH480		
Three-phase voltage (V)	±10%	400	380	460	400	380	460
Frequency (Hz)	±1%	50	60	60	50	60	60
Place of installation	indoor						
Cooling capacity (KW) (*)	47.38			56.98			
Total power installed (standard pump) (kW) (**)	17.2	17.1	17.5	20.9	20.1	20.6	
Total power installed (uprated pump) (kW) (**)	19.8	20.1	20.5	23	22.9	23.3	
Maximum noise level (dBA)	≤80						
Type of refrigerant	R407C						
Refrigerant charge (kg)	7			9			
Type of compressor fluid	Mobil EAL ARCTIC 22CC			Mobil EAL ARCTIC 22CC			
WORK ENVIRONMENT							
Ambient temperature (°C)	version for indoor installation (standard)					7 ÷ 40	
	version for outdoor application with fan speed regulation (special)					-10 ÷ 40	
Maximum altitude (m)	1500						
Transport and storage temperature (°C)	-10 ÷ 50						

Tab.3

(*) Measured in the following conditions: Ambient temperature = 25°C; Temperature of the water entering the chiller = 15°C;

Altitude 0 m; Refrigerated liquid: water without additives.

(**) See wiring diagram.

4. GENERAL DESCRIPTION OF THE MACHINE

4.1. TECHNICAL SPACES, WEIGHTS

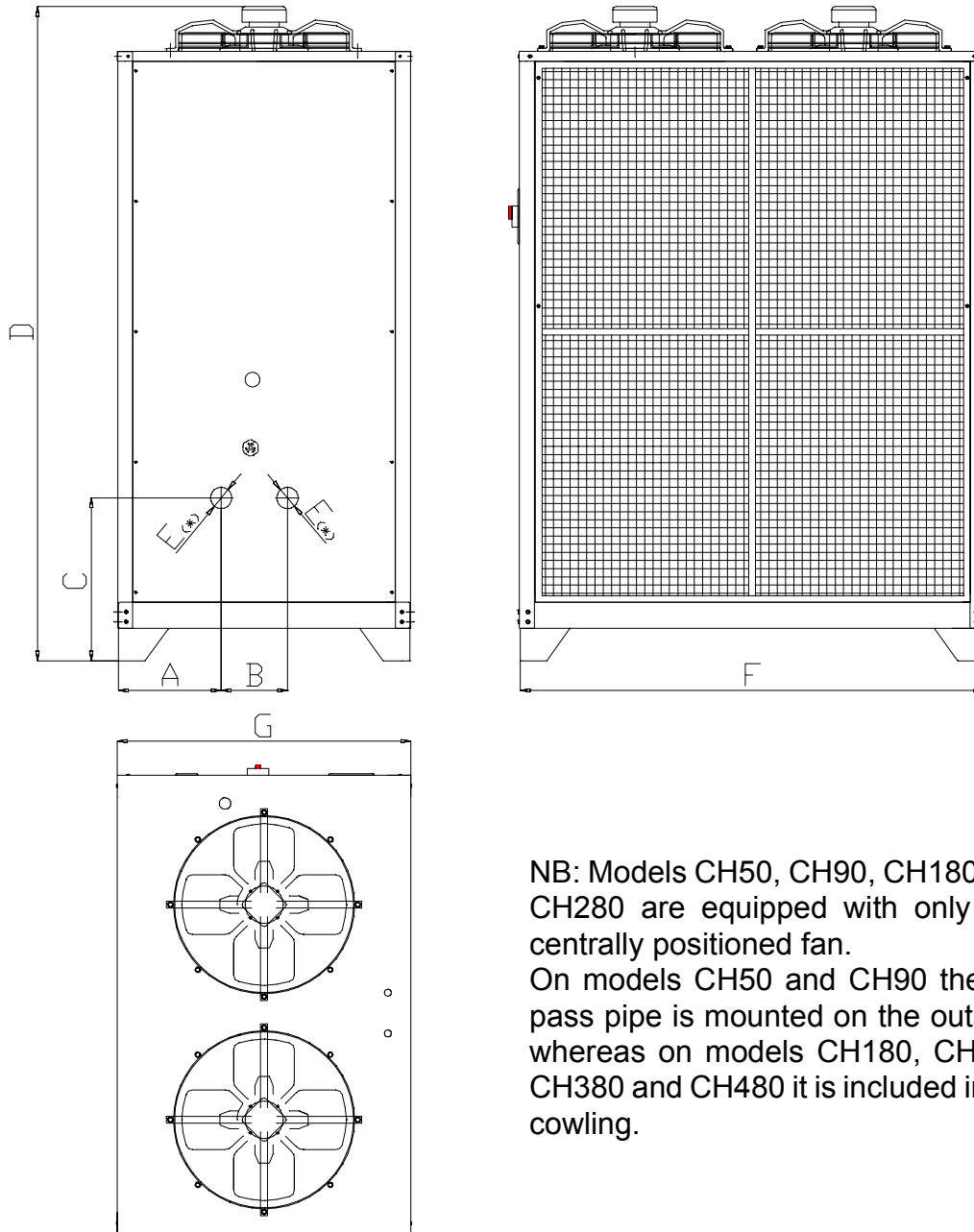

NB: Models CH50, CH90, CH180 and CH280 are equipped with only one centrally positioned fan.

On models CH50 and CH90 the bypass pipe is mounted on the outside, whereas on models CH180, CH280, CH380 and CH480 it is included in the cowling.

	A	B	C	D	E	F	G	WEIGHTS (Kg)
CH50-CH90	391mm	150mm	441mm	1500mm	G 3/4"	1007mm	677mm	230-240
CH180-CH280	310mm	200mm	500mm	1670mm	G 1"	1220mm	886mm	295-370
CH380-CH480	310mm	200mm	500mm	2010mm	G 1 1/4"	1409mm	886mm	460-500

Tab.4

4.2. OPERATION

4.2.1. Hydraulic circuit

The liquid to cool coming from the services enters the circulation pump and is sent through the evaporator where, it is refrigerated thanks to the action of the refrigerant gas that evaporates; from the evaporator it passes through the accumulation tank to be sent back to the services. Motor pump (M1).

Centrifugal with impeller in stainless steel (standard or uprated version).

Inertial accumulation tank

In hot-galvanized iron with anti-condensation insulation, together with a fixed setting safety valve, bleed valve at the highest point and drain tap.

System charging assembly (4)

A pressure reduction unit keeps the pre-charging pressure at a value of 0.5. It is equipped with an integrated pressure gauge and tap to shut off the water supply.

Differential pressure switch (SF1)

This detects a pressure drop within the evaporator by detecting the flow of water. A low water flow rate causes the machine to stop with an alarm.

Anti-freeze protection (BT2)

A probe detects the water temperature immediately at the evaporator outlet. The control thermostat constantly checks this temperature does not drop under the anti-freeze setpoint. If this happens, the anti-freeze alarm triggers and the compressor is stopped. On standard machines the anti-freeze setpoint is set to 4°C.

Manual by-pass

Between the machine inlet and outlet there is a manual by-pass in order to adjust the flow rate of refrigerated fluid to the service.

The sequence to set the by-pass correctly is described below.

N.B. This sequence should be performed with the system fully charged and the pre-charging pressure stabilized.

1. Shut the register of the by-pass completely by turning it fully clockwise.
2. Check that the services are open and they therefore mirror the conditions of normal operation.
3. Set the PIOVAN Chiller working as described in the user manual.
4. Check the working pressure shown on the pressure gauge near the register and directly connected with the piping coming out of the PIOVAN Chiller.
5. If the pressure shown is too high, open the by-pass with the register and turn it anticlockwise to reach the required pressure.

NB: If completely shutting the by-pass trips alarm E41, set the register of the by-pass until the alarm tripping is prevented

4.2.2. Chiller circuit

The refrigerant in a gaseous state on leaving the compressor reaches high pressure and temperature in the pipes of the condenser where condensation takes place via ambient air blown by the fans. Downstream from the condenser, the liquid refrigerant passes through the dewatering filter, the refrigerant gauge and the thermostatic expansion valve, that supplies the evaporator according to the load. On leaving the evaporator, the gaseous refrigerant is sucked in by the compressor.

Compressor (M3)

The compressors are the airtight scroll type. The motors have an internal protection against electric and heat overloads: in addition, they are protected externally by a specific magnetothermal motor cut-out in the electric panel. After any work on the internal thermal protection, normal operation is automatically restored when the temperature of the windings falls under the set safety level in a time that may vary from a few minutes to a few hours.

Lubrication is ensured by a specific integrated pump: oil suction takes place via the casing and it is distributed on the bushings and internal parts subject to sliding.

The oil level in the casing is visible through a sight glass; the sight glass must be half-covered by the oil contained in the casing.

Each compressor has an electric heating element that heats the casing to prevent the refrigerant gas condensing during stoppages and mixing in high percentages with the oil in the casing. The electric heating element must be powered at least 2-3 hours before starting up the machine.

All the compressors are mounted on special rubber mounts to limit the transmission of vibration to the chiller structure.

Condenser (C)

The air-cooled condenser is made up of several rows of mechanically expanded copper tubing with aluminium fins.

The large surface area of exchange ensures proper sub-cooling and therefore the right supply to the thermostatic valve.

The volume of the coils ensures a partial storage of the machine's refrigerant during maintenance.

Filter (17)

This is located on the liquid line and eliminates any debris and moisture from the circuit, preventing acid residues from forming that would damage the compressor.

Liquid and moisture gauge (18)

This is located on the liquid line and signals a sufficient refrigerant charge when the flow of fluid crossing it is clear and constant. If the flow is turbulent with gas bubbles, the machine charge is insufficient (See "TROUBLESHOOTING" on page 39). The chiller circuit must be completely free of moisture, whose level is signalled by the colour taken on by the ring-shaped sensitive element inserted in the gauge.

Solenoid valve (YV1)

Positioned on the liquid line, it prevents refrigerant migrating towards the compressor casing during downtime.

Thermostatic expansion valve (13)

This is mounted right before the evaporator. A sensitive bulb at the evaporator outlet is connected via a capillary tube to the valve body and, opposing the action of the equalization tube, it acts according to the overheating detected, increasing or decreasing the amount of refrigerant entering the evaporator.

The valve is set for gas overheating of 5-7°C to prevent the compressor from being able to draw in liquid.

Evaporator (E)

The evaporator has brazed plates insulated with an elastomer mattress that protects the exchanger from condensation.

High-pressure switch (SP2)

This is located on the compressor delivery line.

It stops the compressor when the condensation pressure exceeds the setting.

Once it has tripped, the pressure switch must be reset manually pressing the reset button located on the switch itself.

Low pressure switch (SP3)

This is located on the suction line. It stops the compressor when the suction pressure reaches the setting.

The compressor can restart when the pressure has increased by the amount of the differential.

Fan control pressure switch (SP1)

This is located on the compressor delivery line.

It controls the operation of the fan(s) according to the condensation pressure. This component is not fitted on the versions for outdoor application where the fans are powered through a speed governor according to the condensation pressure.

4.3. CONTROL PANEL

On the control panel of the machine there is:

QS1: Main switch. This is the point to which the machine's power cables are connected. It can be used to turn off the power under normal conditions or in an emergency.

ST1: Control thermostat. This device guarantees that the water temperature is maintained at the set level and checks the operation of the chiller managing any alarm situations.

HP: High-pressure switch. Checks the gas delivery pressure of the compressor (high-pressure). The reading must be taken on the scale which refers to the gas with which the machine has been charged (see data plate).

LP: Low pressure switch. Checks the gas suction pressure of the compressor (low-pressure). The reading must be taken on the scale which refers to the gas with which the machine has been charged (see data plate).

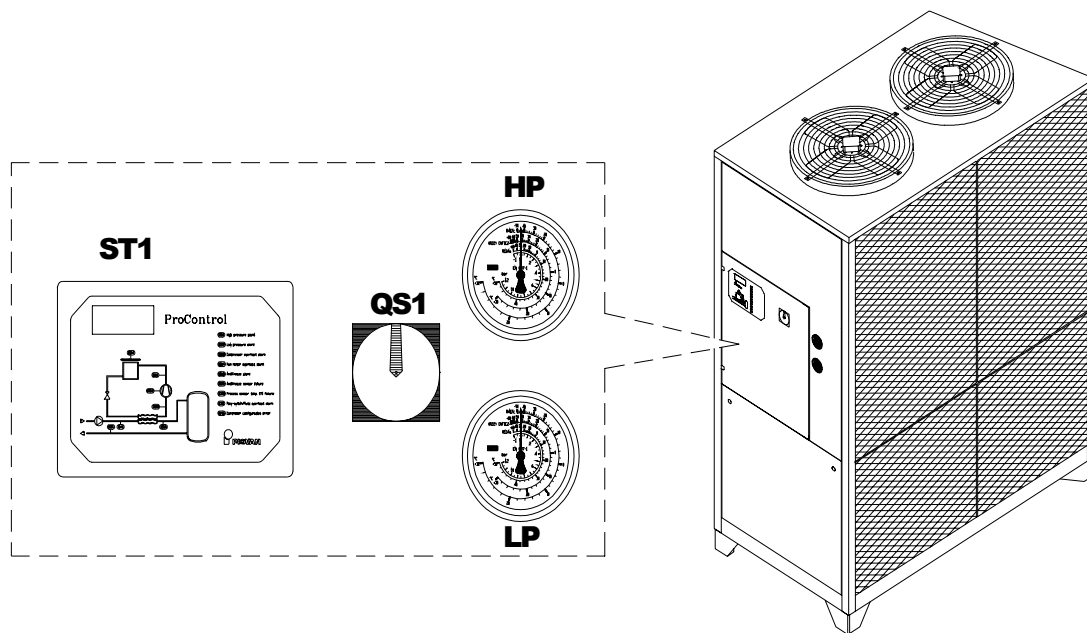

Fig. 3

5. DUCTING FOR HOT AIR LEAVING FANS

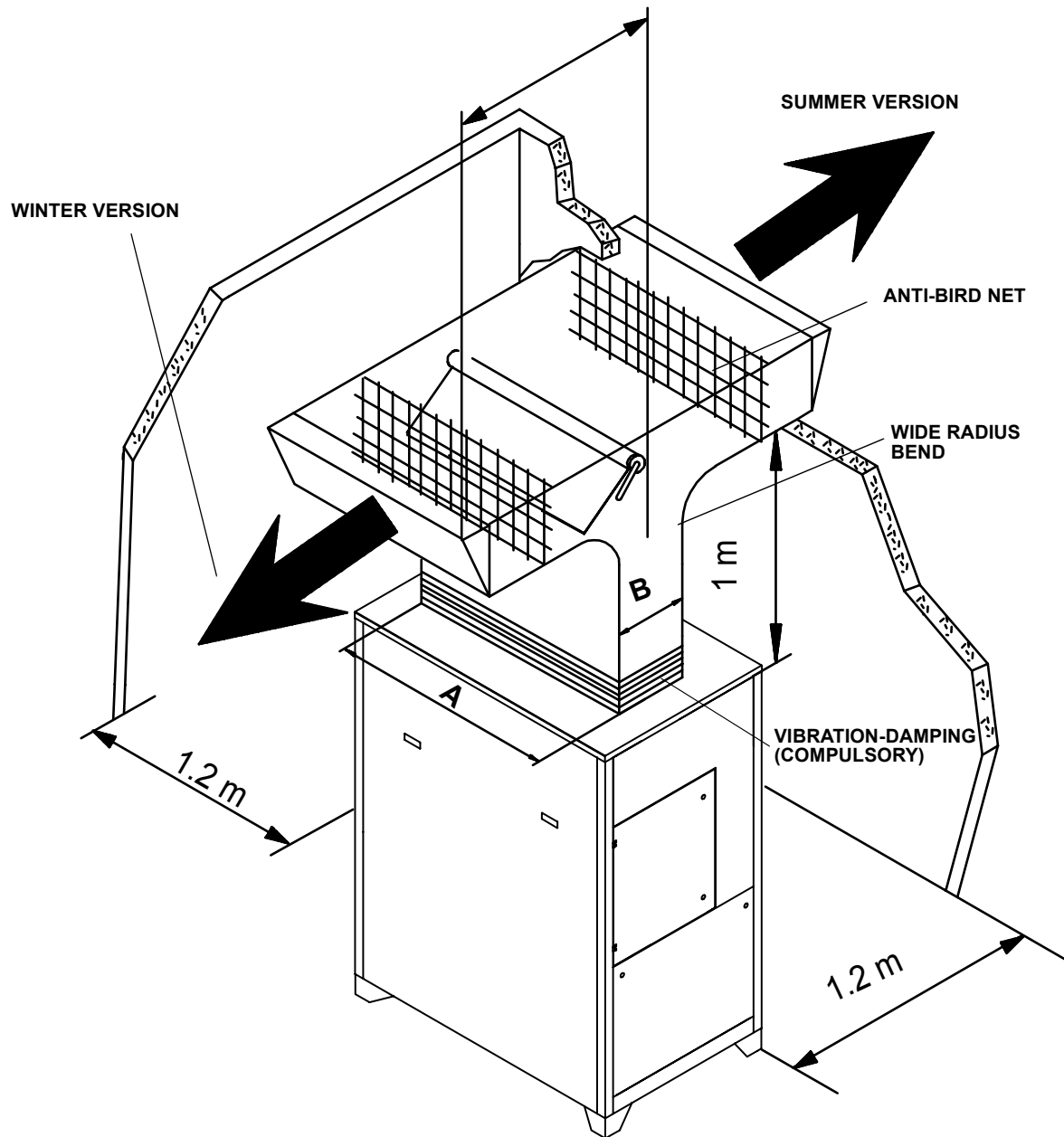

Fig. 4

N.B. The drawing of the ducting represents one example of application.

	A	B
CH50-90	600 mm	600 mm
CH180-280	800 mm	800 mm
CH380-480	1300 mm	750 mm

The chillers in the CH series are equipped with axial fans that cause a certain airflow to circulate through the condenser coils. The passage of cool air into the condensers is necessary to condense the hot refrigerant contained within them under high pressure.

For the same ambient air inlet temperature, the condensation temperature is a function of the quantity of air flowing through the condenser coils. When the airflow decreases, the condensation temperature increases until it reaches the conditions for tripping the high-pressure switch (SP2) and diminishing the cooling capacity of the chiller.

A chiller in which the airflow through the condenser coils diminishes, would therefore have performances and functioning limitations lower than those of a machine with design airflow.

Although the use of axial fans does not originate for the installation of ducting for hot air leaving them, this can be carried out provided that:

- a reduction in the cooling capacity of the machine is accepted, with the ambient temperature and the water temperature on leaving the chiller being equal;
- a reduction in the maximum working ambient temperature of the machine is accepted;
- the instructions given below are complied with.

In the installation of a chiller in the CH series, a maximum reduction in the airflow through the condenser coils of 20% of the nominal airflow is permitted, provided that a reduction in cooling capacity and a reduction in maximum working ambient temperature is accepted. The reduction in the airflow causes a smaller pressure drop in the condenser coil and an increase in the head of the fan. The result of the difference between these two is the useful head for the hot air ducting.

A 20% reduction in the airflow leads to an average reduction in cooling capacity of 4% and to an average reduction in maximum working ambient temperature of 5°C. These values are anyhow approximate and can be subject to considerable increases if further impediments to the correct passage of air through the condenser coils (walls too close, lack of sufficient ventilation in the room, dirty filters, ...) exist.

In the following table the design flow rates for each model of CH chiller and the available head for the hot air ducting are given considering a reduction in flow of 20%.

Chiller model	No. of fans	Nominal flow rate per fan [m ³ /h]	Flow rate reduced by 20% per fan [m ³ /h]	Available pressure drop [Pa]
CH50	1	6100	4880	76
CH90	1	5600	4480	75
CH180	1	7800	6240	29
CH280	1	8300	6640	35
CH380	2	2 X 7500	2 X 6000	67
CH480	2	2 X 7200	2 X 5760	71

Tab.5

In indicating the flow rates of air, a single fan is considered; all the following considerations refer to a single fan, the number of ducts in machines with two fans will have to be doubled.

For calculating the pressure drop in the air distribution ducts, the following data have been assumed:

- Air density of 1.204 kg/m³. This value is really a function of the air temperature and the height above sea level, but can be considered valid for a broad work field.
- Galvanized expulsion ducts (maximum roughness $\epsilon = 0.09$ mm) and joints about every 1.2 m.

In calculating air-pressure drop of the duct, both the distributed pressure drop (the duct itself) and the concentrated pressure drop (bends, expulsion outlets, shutters, ...) will have to be considered

With regard to the **distributed pressure drop**, refer to Fig. 13 page 43, where the air-pressure drop values are given in Pa/m according to the airflow in l/s and the diameter of the duct in mm and to Fig. 14 page 43, where the equivalent diameters for the rectangular section ducts are given.

When choosing the duct diameter always stay within the grey zone.

As regards the concentrated pressure drop, the bends, the expulsion outlets and the various shutters can be traced back to a certain number of equivalent lengths of round duct. Consider the values given in table no. 6.

Components typology	Equivalent length
90° bend with ratio of 1:1 between radius of curvature and diameter.	17 m
90° bend with ratio of 2:1 between radius of curvature and diameter.	10 m

Tab.6

For other components, refer to the manufacturer's instructions.

One last consideration must be made about the height of the duct outlet compared to the level of the fan (h). In fact, an additional "pressure drop" must be considered, of:

$$\Delta P = 1.204 \times 9.8 \times h = 11.8 \times h \text{ [Pa]}$$

5.1. EXAMPLES OF SIZING EXPULSION DUCTS

Example of calculation "A"

A CH480 has to be ducted to expel hot air from the condensers at a height of 1 metre above the level of the fans.

In table no. 5 it says that the nominal flow of the machine fans is 7200 m³/h (second column).

On the chillers in the CH series, a maximum reduction in the airflow of 20% is permitted. The airflow to be allowed for will therefore be 5760 m³/h per fan (penultimate column).

With this flow, the head of the fan available for the ducting is 71 Pa (last column).

Suppose one wants to duct the air with a section of 500 x 500 mm square duct to a height of 1 m above the level of the fans, and one then wants to bring the duct into a horizontal position with a bend to then expel the hot air (Fig. 4 page 16). One therefore wants to know the maximum length of the horizontal section of the duct.

In the diagram of Fig. 14 page 43, it says that a duct with a 500 x 500 mm cross-section is equivalent to a round duct of 550 mm

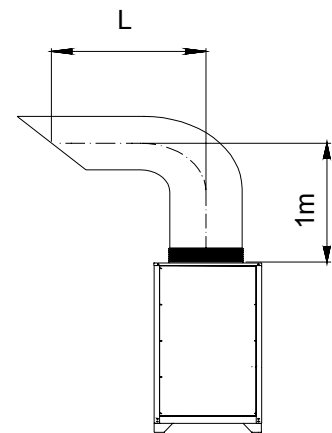

Fig. 5

In the diagram of Fig. 13 page 43, with an airflow of 5760 m³/h, equivalent to $5760 \times 1000 / 3600 = 1600$ l/s, the following values can be read:

- Distributed pressure drop = 1.2 Pa/m;
- Air speed 7.5 m/s (needed for calculating the concentrated pressure drop in some ducting component catalogues).

The bend (considering a radius/diameter ratio of 1), will lose the equivalent of 17 m of duct, that is $17 \times 1.2 = 20.4$ Pa

To take the air to a height of 1 m, 1×11.8 Pa = 11.8 Pa will be necessary and the vertical metre of duct loses $1 \times 1.2 = 1.2$ Pa.

As a final loss, the drop in air-pressure on leaving the duct must be considered (called loss due to sharp outflow),

equal to $1 \times (0.612v^2) = 35$ Pa, where v indicates the air speed in the duct (7.5 m/s).

Considering, then, that the available head with a reduction in the nominal flow of 20% is 71 Pa, the maximum length of the horizontal section will be:

$$\text{Maximum duct length} = \frac{71 - 1.2 - 20.4 - 11.8 - 35}{1.2} = 2.2 \text{ m}$$

This obviously does not take into account other components that might be installed such as shutters, expulsion grilles or other things that might lead to a large reduction in the maximum length.

Example of calculation "B"

If we wanted to expel the air with a vertical duct, we should allow for:

Air-pressure drop at bend = $17 \times 1.2 = 20.4 \text{ Pa}$

Air-pressure drop due to outflow = 35 Pa

Therefore we have:

$1.2 \times L = 71 - 20.4 - 11.8 \times L - 35$ where L is the maximum duct length.

$$\text{That is } L = \frac{71 - 20.4 - 35}{11.8 + 1.2} = 1.2 \text{ m}$$

This obviously does not take into account other components that might be installed such as shutters, expulsion grilles or other things.

Attention is paid to how having to expel air upwards is much more important than having to make horizontal sections of duct.

As a general rule, when sizing ducting for these machines, as far as possible try to use ducts with a large cross-section and with as few bends and narrowings or supplementary components as possible. Special attention must also be paid to the wind direction that could slow down, or even reverse, the airflow.

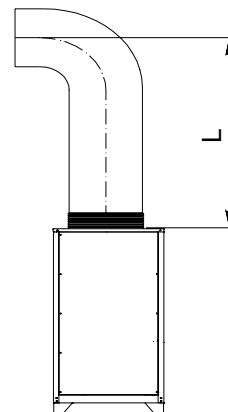

Fig. 6

6. CONTROL THERMOSTAT

6.1. CHARACTERISTICS

The control thermostat installed on the chillers in the CH50-480 series is an electronic control device with a microprocessor that can detect and process the signals necessary to operate the devices that make up the chiller itself. In order to perform the functions listed above, the thermostat makes use of: a set of digital and analogue inputs, a suitably configured electronic board, a user interface system (display and keys), a set of digital outputs and an analogue output. The temperature of the water leaving the chiller, temperature of the water leaving the evaporator and (for the machines supplied with fan speed control) compressor delivery gas pressure are detected via the analogue inputs. The first quantity is the temperature that the control refers to for carrying out the thermoregulation, the second is the temperature detected at the coldest point in the hydraulic circuit and is therefore used for activating the anti-freeze alarm. Whereas, with the aid of the digital inputs, the thermostat can detect the status of the following devices: internal thermal overload protection of the compressor or integral protection, contact for remote ON/OFF, miniature circuit breakers, motor cut-outs, differential pressure switch or flowmeter, condensation pressure switch, high-pressure switch and low-pressure switch.

6.2. USING THE KEYS AND READING THE DISPLAY

The user interface is composed of a display (three digits plus a set of LEDs) and two keys. During normal operation the display shows the process temperature. During configuration, it shows the code of the various parameters and the relative value and, when there is an alarm, it shows the code for that alarm. The two keys

can be used to reset an alarm, to turn the chiller on or off and to scroll and select the groups of parameters and the parameters themselves.

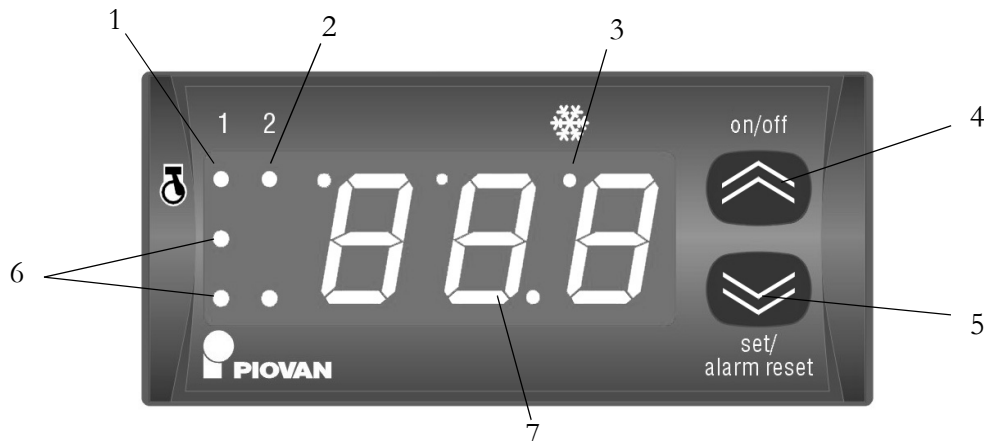

Fig. 7

There follows a table summing up the function of the display and the use of the keys

Ref.	Description
1	Indicates the state of the compressor: <ul style="list-style-type: none"> • Alight = compressor turned on. • Off = compressor turned off. • Blinking = timing calculations are in process to prevent the compressor stopping and starting too often.
2	Indicates the status of the hot gas injection solenoid valve or choking (optional): <ul style="list-style-type: none"> • Alight = choking not active. • Off = choking active. • Blinking = timing calculations are in process to prevent the solenoid valve stopping and starting too often.
3	Indicates the status of the chiller; when it is alight, the chiller has been activated by using the relevant key (4).
1+6	These three LEDs blink (the two outside ones come on, alternating with the inside one) to indicate that the component is undergoing configuration, or that some parameters or the setpoint are being modified.
7	The display can show: <ul style="list-style-type: none"> • Temperature of the process fluid. • Codes of the various parameters and if necessary the value assigned to these. • Alarm codes (if installed). • Abbreviations of the various groups and sub-groups of parameters. • OFF status from remote input (abbreviation E00 blinking).
4	It has several functions: <ul style="list-style-type: none"> • Turns the chiller on/off. • During configuration, it can scroll any list of variables (groups and sub-groups of parameters and the parameters themselves), and can also increase the value of the parameter selected.
5	It has several functions: <ul style="list-style-type: none"> • During normal operation, if pressed for longer than 2 sec., it enables the display and the following modification of the current setpoint. The desired modifications can now be made, then it is necessary to wait for about 10 sec. (until LEDs 1 and 6 stop blinking) for the new value to be memorised and the display to return to normal conditions. • During configuration, it can scroll any list of variables (groups and sub-groups of parameters and the parameters themselves), and can also decrease the value of the parameter selected. • If the alarm triggers, it resets it (if the condition that caused it no longer persists).
4+5	When pressed simultaneously, it is possible to scroll and select the various groups and sub-groups of parameters.

Tab.7

6.3. MOST COMMON PROCEDURES

Switching on the chiller: Press key “4”, the LED “3”, lights up, indicating chiller start-up.

Switching off the chiller: Press key “4”, the LED “3”, switches off, indicating the chiller has stopped.

Changing the setpoint: Press key “5” for longer than 2 sec., LEDs “1” and “6” begin to blink and the current value of the setpoint appears. Make the desired modifications and wait for about 10 sec. The process temperature reappears, LEDs “1” and “6” stop blinking and the new setpoint value has been saved.

Editing a parameter: Access to the various parameters is organized in sublevels that can be accessed by pressing keys “4” and “5” simultaneously. To scroll through the contents of the sublevels press keys “4” or “5” individually. Each menu level and then each parameter is identified by a code. The structure is shown in Fig. 15 page 44. To quit the configuration wait for 10 sec. or press keys “4” and “5” simultaneously for longer than 2 sec.

Resetting an alarm: When an alarm situation arises a code is displayed and the relative procedure is activated. Upon return to normal conditions (the cause of the alarm no longer exists) the control must be reset by pressing and releasing key “5”. If the alarm does not reset when carrying out this procedure, it means that the cause that provoked the alarm still persists.

6.4. CONFIGURATION DIAGRAM

As already described, the various configuration parameters are split into groups. Accordingly, if a parameter has to be edited, the relative code in the list of parameters has to be identified, go back to the group that it belongs to and then (Fig. 15 page 44) establish the path to reach it. In order to prevent modifications being carried out that would damage the chiller, not all the parameters can be modified. In the diagram the dotted squares indicate that parameters that cannot be modified or seen, while the padlock symbol distinguishes the parameters that need a password.

6.5. MAIN FUNCTIONS

Temperature Control

The essential parameters for temperature control are the setpoint (ST1) and the differential (C03). The graph below schematizes the operation of the temperature control.

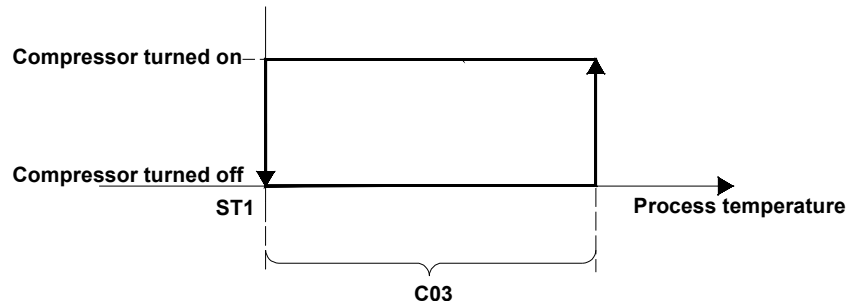

Fig. 8

Condensation control

Condensation control is performed in two different modes depending on the type of machine. On standard chillers, a set pressure switch operates the fans, while on chillers equipped with speed regulation the pressure is detected by the control thermostat, which, depending on the condensation setpoint value, sends an analogue signal to the speed regulator. In both cases, the purpose of the regulation is to maintain the condensation pressure within a certain value.

Monitoring working hours

The regulator records the working hours of the compressors and the pump. These values can be displayed scrolling through the parameters contained in the group OHR (OH1=compressor working hours and OHP=pump/chiller working hours).

Anti-freeze control

The second probe (BT2) on the evaporator outlet before the accumulation lets the control carry out the anti-freeze control. In case the water temperature falls below the anti-freeze alarm setpoint (parameter A11).

Remote ON/OFF

The control thermostat is equipped with a digital input with which it is possible to turn the chiller on or off from a remote station. By referring to the attached wiring diagram, it is possible to identify the two terminals (No. 16 – 23) to connect the clean contact for remote ON/OFF (contact open = OFF, contact closed = ON). To do this, the jumper that is connected at the general test and inspection stage has to be disconnected. At this stage, the chiller **has to be enabled by the ON/OFF button** (the ON LED lights up) and, following this, it can be stopped and restarted from the remote station by opening and closing the contact.

Alarm management

For every alarm condition there is a corresponding code and procedure. As already mentioned, the alarms can be detected by the digital inputs or by the analogue inputs. In the electric panel (on the terminal board) a clean contact is available that signals the tripping of one of the alarms listed above (terminals 33 – 34). Still on the terminal board, it is possible to connect an alarm siren (terminals 4 – 32). Remember that all the alarms must be reset manually (see use of keys). If more than one alarm trips, the control displays the first alarm that trips. The next alarm is displayed only after the first alarm has been reset.

7. INSTALLATION

7.1. REQUISITES OF THE ROOM - POSITIONING

There must be sufficient free space around the perimeter of the machine to guarantee easy access to all the parts that need servicing and to the service and control members.

Machines with air condensing must observe the minimum distances around the perimeter in order to guarantee proper ventilation of the condensing coils.

The stated maximum ambient temperatures take into account the correct installation of the machine. **Incorrect installation inevitably leads to a reduction in this value.**

Installation must be carried out by specialized personnel.

Never install the machines in harsh environments, in small rooms or rooms with poor ventilation and the risk of re-circulating condensation air. The chiller can only be installed in the open if it is in the version for outdoor application (special) and must be protected from atmospheric agents by a special canopy. In any case observe the instructions regarding positioning given in the section “REQUISITES OF THE ROOM - POSITIONING” on page 22

Position the machine on a flat surface. If installing on an elevated surface, make sure it is adequately structured and scaled to bear the weight of the machine and big enough to accommodate it.

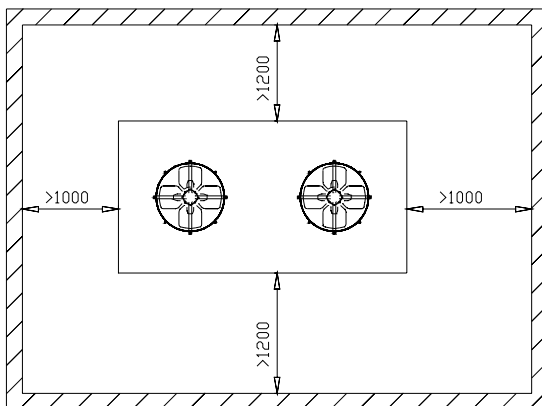

Fig. 9

Observe the minimum distances for positioning (Fig. 9 page 23), to guarantee easy access to all the parts that need servicing and to the service and control members.

Machines with air condensing must observe the minimum distances around the perimeter in order to guarantee proper ventilation of the condensing coils.

Do not obstruct the flow of cooling air of the condenser. Position the chiller so that the air expelled from the fans cannot recirculate into the suction filters.

Make certain that the chiller is not assailed by the hot air coming from the cooling systems of other machines. The flow of hot air leaving the fans must absolutely not meet any obstacles that might impede the diffusion of hot air into the environment.

A minimum height of 3 metres between the fan outlet and any obstacle is permitted.

If more than one unit is installed, the minimum distance between the refrigerating units must be no less than 2 metres, to prevent interference in the working of the fans of each machine.

An installation that does not take into account the recommended technical spaces will cause the machine to function poorly and will result in **a considerable reduction in the refrigerating power delivered, an increase in consumption and a substantial reduction in maximum working temperature.**

If necessary, duct that air outlet of the fan(s) complying with the maximum lengths and cross-sections given in the section “DUCTING FOR HOT AIR LEAVING FANS” on page 16; provide suitable aeration for the reintegration of the expelled air.

If installed in a closed place the room must be well ventilated. In some cases it might be necessary to install fans or extractors in the room to limit its temperature.

The ambient air must be clean and contain no flammable gases or solvents. The minimum and maximum working temperature are specified in the section “TECHNICAL DATA” on page 10.

7.2. REFRIGERATED WATER DISTRIBUTION NETWORK

7.2.1. Head of the pump on the machine and head at the service

Due to a drop in pressure in the refrigerated water distribution circuit, the head at the service will be lower than that stated in the pump characteristics.

For this reason, when installing the chillers, it is necessary to size the pipes of the hydraulic system correctly. Incorrect sizing can significantly decrease the performance of the pump installed on the machine, in terms of both head at the point of use and rate of flow.

For this reason the instructions in this manual must be strictly followed or a designer must be used to size the plant correctly.

Piovan S.p.a. shall not be held responsible for a decrease in chiller performance or for any trouble deriving from poor installation.

7.2.2. Ratio between pipe lengths and diameters

The following table gives the diameters of the hydraulic pipes according to the distances they travel (out + return) with the following:

1. Use of trade pipes made of steel;
2. Thermal conveying fluid = water without any additives (see water specifications paragraph)
3. Straight pipes (no bends, valves, filters or other components that might cause a drop in pressure).

By using the following diameters, the drop in pressure of the refrigerated water distribution line is limited to 0.5 bars.

Chiller model	Nominal flow rate [m ³ /h]	Length of piping (out + return)						
		L=10m	L=20m	L=30m	L=40m	L=60m	L=80m	L=100m
CH50	1.7	1/2"	3/4"	1"	1"	1"	1"	1" 1/4
CH90	3.0	3/4"	1"	1"	1" 1/4	1" 1/4	1" 1/4	1" 1/4
CH180	6.0	1"	1" 1/4	1" 1/4	1" 1/2	1" 1/2	2"	2"
CH280	9.3	1" 1/4	1" 1/4	1" 1/2	2"	2"	2"	2" 1/2
CH380	12.7	1" 1/4	2"	2"	2"	2" 1/2	2" 1/2	2" 1/2
CH480	16.0	2"	2"	2"	2" 1/2	2" 1/2	2" 1/2	2" 1/2
--	23.3	2"	2" 1/2	2" 1/2	2" 1/2	2" 1/2	3"	3"
--	30.0	2"	2" 1/2	2" 1/2	2" 1/2	3"	3"	4"

Tab.8

If any bends or elbows are included in the piping, besides the pressure drop of 0.5 bars, consider also the following additional values for each component installed.

If the hydraulic circuit is charged with a solution of water and ethylene glycol, increase the losses according to the following corrective factors:

Overall length of piping [m]	Elbow [bars]	Bend [bars]
10	0.12	0.09
20	0.05	0.04
30	0.04	0.03
40	0.03	0.02
60	0.02	0.02
80	0.02	0.01
100	0.01	0.01

Tab.9

% Ethylene glycol in the water	Increase in load loss
0	0%
5	4%
10	8%
15	12%
20	17%
25	21%
30	25%
35	29%
40	33%
45	37%
50	41%

Tab.10

Example of calculation:

It is necessary to install a chiller model CH380 to cool the water in a mould at a distance of 10 metres, using a 20% solution of ethylene glycol for the fluid and having to insert 4 bends and 6 elbows in the hydraulic piping. See Tab. 8 page 24, at model CH380 and the column for 20 metres (10 out and 10 back), you find that the diameter to use for the pipes is 2". With this diameter, just the pipes will lose 0.5 bar.

In Tab. 9 page 25, it is possible to obtain the losses of the bends and elbows. Overall, these components will therefore lose $4 \times 0.04 + 6 \times 0.05 = 0.46$ bar.

Using a solution of water and ethylene glycol, the drop in pressure in the circuit must be increased by 17%, so we have:

$$\text{Total pressure drop} = (0.5 + 0.46) \times 1.17 = 1.1 \text{ bar.}$$

This value has to be subtracted from the head of the pump. The result will be the head at the service.

7.2.3. Hydraulic circuit pre-charging

The automatic charging valve is factory set to a pressure of 0.5 bars

This value permits correctly charging the system in the event of water loss due for instance to changing a mould in the hydraulic circuit.

7.3. MACHINE CONNECTIONS TO THE REFRIGERATED LIQUID DISTRIBUTION NETWORK

Connect the chiller to the water pipes and to the water supply (or to an appropriate charging assembly). Provide:

- two taps (one on the inlet and one on the outlet) to cut off the machine in the event of maintenance without having to drain the water from the service circuit.
- automatic breather valves at all the highest points of the water circuit.
- expansion tank (not needed in the case of an open circuit on pump suction).

To calculate the minimum volume of the expansion tank needed for a certain installation, it is possible to use the following calculation.

The volume of the expansion tank V in litres is given by the formula:

$$V_{\text{tot}} = 2 \cdot V_t \cdot (P_{\text{tmin}} - P_{\text{tmax}})$$

where:

V_{tot} = Total circuit volume in litres.

P_{tmin} = Specific weight at the minimum temperature the water can reach in the course of a year in °C (also with the system at a standstill)

P_{tmax} = Specific weight at the maximum temperature the water can reach in the course of a year in °C (also with the system at a standstill)

Example of calculation:

$V_{\text{tot}} = 200$

Percentage in volume of ethylene glycol = 30%

$t_{\text{min}} = 5^{\circ}\text{C}$ from the table $P_{\text{tmin}} = (1.045+1.041)/2 = 1.043$

$t_{\text{max}} = 40^{\circ}\text{C}$ from the table $P_{\text{tmax}} = 1.0282$

$V = 2 \cdot 200 \cdot (1.043 - 1.0282) = 5.92$ litres

Table of specific weights P

% Glycol	0°C	10°C	20°C	30°C
0%	1.0008	0.9988	0.9964	0.9936
10%	1.0155	1.0130	1.0101	1.0067
20%	1.0303	1.0272	1.0237	1.0199
30%	1.0450	1.0414	1.0374	1.0330
40%	1.0669	1.0635	1.0598	1.0556

Tab.11

7.4. ELECTRICAL CONNECTIONS

Check that the supply voltage and frequency conform to those of the machine's data plate and that they are within the tolerances stated in Tab. 3 page 11.

Make sure the electrical installation conforms to the binding laws and regulations at the place of installation.

The power cable must be sized for the electrical characteristics of the chiller.

For connection to the electric mains, protection with a rating of at least IP2X or IPXXB must be guaranteed and devices that meet the following indications must be installed:

1. protection against overcurrent of the power cable.
2. short-circuiting current limited to a peak of 15 kA in correspondence with its rated breaking capacity if the short-circuiting current envisaged at the point of installation is effectively greater than 10 kA;

3. protection against indirect contacts on the machine (short-circuiting between live and the equipotential protection circuit) automatically cutting off supply according to the requirements of the IEC 364 - HD 384 - CEI 64-8 standard. For this purpose, use an RCD (normally with a rated residual current of 0.03 A).
4. protection against a lack of phase in the case of three-phase power supply.

For the sizing of the protection circuit, refer to the data given in the section “TECHNICAL DATA” on page 10 and possibly in the attached wiring diagram.

Before making the electrical connections to the supply mains, it is necessary to make the following checks:

- the integrity of the electric components, which must show no sign of wear or burning;
- the maximum unbalance between phases has to be less than 3%. Higher unbalance nullifies machine warranty.

To calculate the unbalance, follow the example given (consider a three-phase power supply voltage of 400V):

the voltages between the three-phase connecting points have been measured with a voltmeter;

voltage L1 - L2 = 393V;

voltage L2 - L3 = 401V;

voltage L1 - L3 = 403V;

mean voltage = $\frac{393 + 401 + 403}{3} = 399\text{V}$;

the maximum voltage difference between the phases is $399 - 393 = 6\text{V}$;

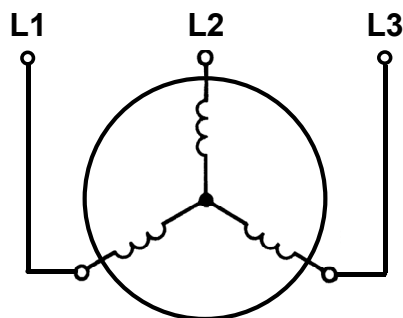

the unbalance between the phases is $\frac{6}{399} \cdot 100 = 1,5\%$ and is acceptable because it is under 3%.



WARNING!

Supply values that fail to come within the guidelines in Tab. 3 page 11 nullify machine warranty.

Use an electric cable of cross-section suited to the total machine power. See Tab. 3 page 11 or attached wiring diagram.

Connect the power cable, through the cable clamp provided, to the terminals of the main switch (QS1), following the wiring diagram.

THE MACHINE SHOULD BE CONNECTED TO AN EFFICIENT EARTH SOCKET.

7.5. FILLING WITH WATER

- Connect the water from the water supply to connection (5);
- open the tap (6) and the ball valve (2);
- if necessary, use the pressure reduction unit (4) to set the charging pressure to 50 kPa (0.5 bars, already adjusted at the manufacture factory), measured on the pressure gauge (7). The machine is supplied with a pressure reduction unit already set to 50 kPa (0.5 bars);
- wait for water to come out of the ball valve (2) with a constant flow. It is important to prevent air pockets from being left in the tank;
- shut off the ball valve (2) and open (only for CH180, CH280, CH380 and CH480) the (2a).
- when charging is complete, shut off tap 6.
- If required by current regulations in the country of installation, it may be necessary to install suitable equipment (hydraulic disconnectors) to prevent polluting the water supply mains with the water of the refrigerator's hydraulic circuit.

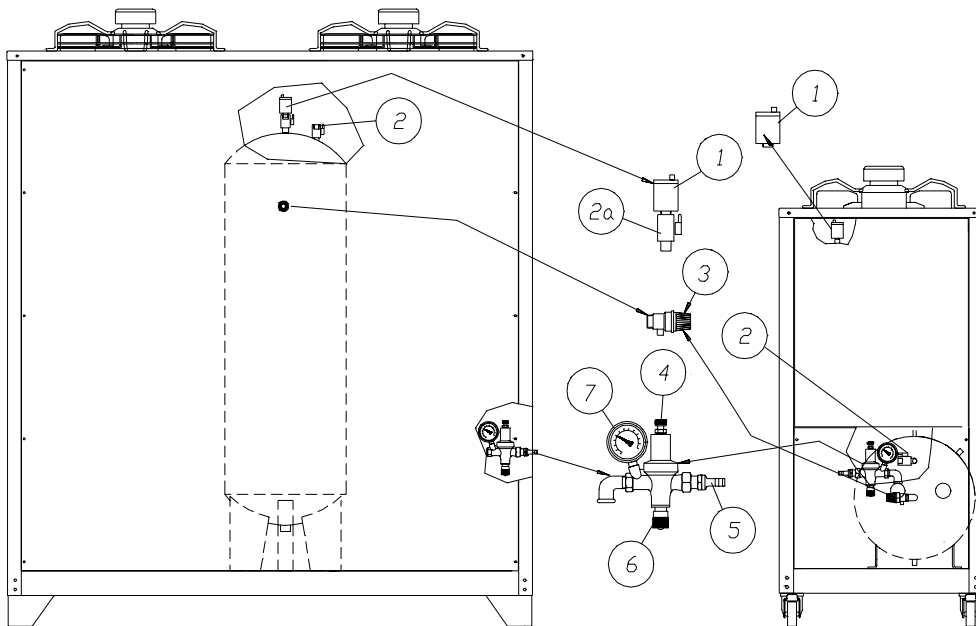

Fig. 10

7.6. BLEEDING AIR FROM HYDRAULIC CIRCUIT (SERVICES)

Correct chiller operation requires the air in the hydraulic circuit to be efficiently eliminated. To achieve this, it is necessary to fit the following components on the line connecting the chiller with the services:

- automatic air breather valves to be fitted at the highest points of the system;
- manual air breather valves to be fitted at the highest points of the system.

Air breather valves are needed for the hydraulic lines on the floor, too, not necessarily to be fitted at the highest points of the system.

For systems supplying a high number of service machines that, in their turn, involve frequent mould changing and therefore air entering the circuit, it is wise to fit an accumulation tank and air bleed on the return pipe from the services to the chiller.

7.7. ANTI-FREEZE PROTECTION

Even if the minimum ambient working temperature is higher than 0°C, during the cold season the chiller might be in a place where the temperature is below 0°C. In these cases, if the chiller is not drained, it is necessary to add an anti-freeze fluid to prevent ice forming (ethylene glycol or another fluid compatible with the materials used) in the following percentages:

Min. ambient temp. [°C]	Ethylene glycol [% in volume]
< 10	10
-5	15
-10	20
-15	30
-20	35

Tab.12

Minimum water outlet temperature [°C]	Ethylene glycol [% in volume]
< 5	10
0	15
-5	20
-10	30
-15	35
-20	40

Tab.13

Depending on the refrigerated water outlet temperature, to prevent ice forming, it is necessary to add anti-freeze (ethylene glycol) in the following percentages:

Depending on the percentage of glycol added to the water system, the cooling capacity will decrease as shown in the following table:

Loss of cooling capacity [%]	Ethylene glycol [% in volume]
1.0	10
1.5	15
2.0	20
3.0	30
3.5	35
4.0	40

Tab.14

For the increase in drop in pressure of the system after adding anti-freeze, refer to “Connecting the machine to the refrigerated liquid distribution system”.

8. START-UP

8.1. PRELIMINARY CHECKS

Before going ahead and starting up the chiller, make sure all the personnel have read and understood the section on SAFETY in this manual.

Check that the shut-off valves on the water system are open.

Fully open the by-pass gate installed between the delivery and return pipes of the chiller.

Open the water charging tap underneath the pressure reduction unit.

Open the side inspection panel (on the side opposite the condensation air suction filter) and check that the tank is completely full of water and that the air has been properly bled.

If the hydraulic circuit is the closed type, check an expansion tank of suitable capacity has been installed

Check (with the water pressure gauges) that the pressure in the water circuit is approximately 0.5-1 bars to make sure that during operation the pump does not lower the pressure in parts of the circuit (risk of cavitation) causing air to get in (preventing both manual and automatic breather systems from working) and any hoses to implode (which would prevent the regular flow of water).

Check that the ambient temperature is in the limits stated on the machine data plate.

Check that the main switch is turned to OFF.

Check that the supply voltage is correct.

Use the supply line protection device to power up the machine.

Turn the machine's main switch to the "ON" position; the control thermoregulator will begin to display the actual temperature of the water leaving the chiller.

Wait for the oil to warm up in the compressor casing for about 2-3 hours. In normal use, leaving the equipment live even in production downtime, when starting up afterwards it will not be necessary to wait for the oil to heat since the casing heating element stays on even if the chiller is not working.

Press the ON/OFF button on the thermoregulator; **the pump starts immediately.**

Check the pump turns in the right direction. If necessary, after having cut off the power, swap over two phases on the chiller power supply line. **CAUTION!** Do not reverse the direction of rotation of solely the pump.

With the pump running, check that the pressure difference between the reading on the delivery pressure gauge (located on the rear panel) and the reading on the return pressure gauge (located on the pressure reduction unit of the filler assembly inside the machine) is greater than the available head at maximum pump delivery (see "Technical Data" section). If this difference is less, it means that the water flow rate is greater than the maximum permissible amount. **So as not to damage the pump, it is necessary to increase the pressure drop in the hydraulic circuit, e.g. by partly shutting a pump delivery tap.**

When starting up the first time , if the ambient temperature is high and the temperature of the water in the hydraulic circuit is much higher than its working temperature (e.g. **25-30°C**) it means the chiller starts overloaded with the protection devices **possibly tripping. To reduce this overload, you can progressively close a chiller outlet valve to decrease the flow of water crossing through it.** As the temperature of the water in the hydraulic circuit reaches its working temperature, open the valve.

The machine is now ready to work.

If the thermal load is lower than that produced by the chiller, the water temperature drops until it reaches the setpoint value and the compressor stops: the water pump continues running.

9. SWITCHING OFF THE CHILLER



WARNING!

In the event of an emergency, turn the main switch QS1 onto 0 (OFF). Use this procedure only in case of need and not as a routine procedure.

To stop the chiller press the ON/OFF key.

It is advisable to keep the machine powered (QS1 in position 1 (ON)) to avoid having to wait for the oil in the compressor casing to warm up, or, if the machine is intended to be left inactive for a long time, turn switch QS1 to position 0 (OFF) to cut off the power.

10. SERVICING THE CHILLER

10.1. GENERAL INFORMATION



WARNING!

Carefully read the “SAFETY” section before carrying out the following operations.

All maintenance work (unless indicated otherwise) must be performed with the machine switched off and disconnected from the electric power supply line.

To access the components inside the machine, use the following diagram (Fig. 11 page 31):

From **side A** it is possible to access: connections to the water supply.

From **side B** it is possible to access: condenser.

From **side C** it is possible to access: electric panel.

From **side D** it is possible to access: chiller and hydraulic circuit.

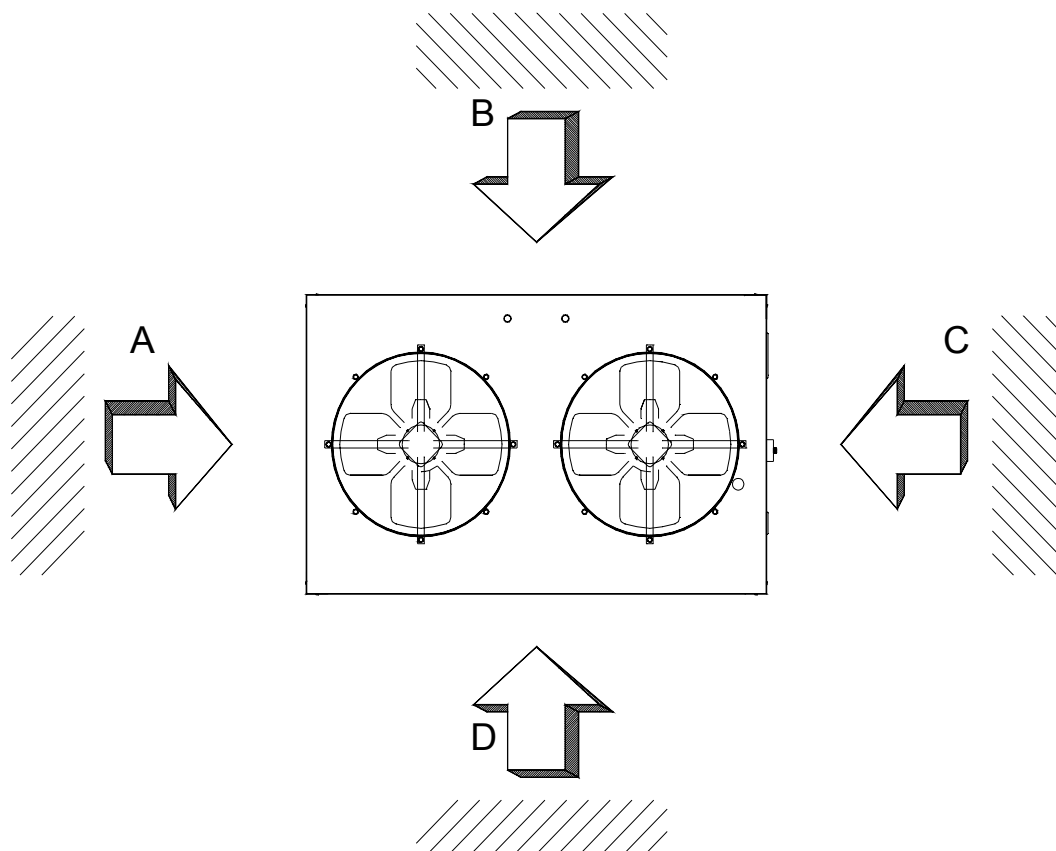

Fig. 11

10.2. SCHEDULED MAINTENANCE

Every week	<p>Cleaning air filters: take out the filters, clean with an extractor and, if necessary, wash them.</p> <p>Checking the inside for water leakage and condensation: take off the closing panels; tighten the fittings if necessary and restore the insulation.</p> <p>Cleaning water filter cartridge (optional): thoroughly wash under running water with a soft brush and, if necessary, replace it.</p>
Every month	<p>Checking and cleaning the condenser: take out the filter and, if necessary, clean the condenser using an extractor. Protect the internal components with a sheet.</p> <p>Electrical check: check and clean the electric panel with the main switch QS1 in the OFF position. Check the tightness of the clamps, check the state of wear of the contacts of the contactors and replace them if necessary. On the version for outdoor application also clean the panel aeration filters.</p> <p>Mechanical check: thoroughly clean the inside of the machine and check the tightness of the bolts fixing the various components.</p> <p>Oil level: with the machine stationary for over half an hour, check the level through the sight glass located on the compressor; if this has fallen under a third of the sight glass, call the PIOVAN technical assistance service. The type of fluid to use is stated in par. 3. - Technical Data. Never mix different oils.</p> <p>General check: Search for any leakage with a specific leak finder, taking the end of the probe close up to all the fittings and welds.</p>

Tab.15

10.3. UNSCHEDULED MAINTENANCE

Repairing the chiller circuit

Any repairs to the chiller circuit that may become necessary have to be performed solely by skilled chiller technicians.

If repairs have been made, it is necessary to carry out the following operations.

- Leak test
- Forced vacuum and circuit drying
- Charge with refrigerant

Leak test

Charge the circuit with anhydrous nitrogen from a cylinder fitted with a reduction unit to reach a pressure of approximately 15 bars.

Any leaks will have to be identified with a bubble-type leak detector; any bubbles and/or foam indicate the location of leaks; in which case, before repairing, drain the circuit again.

Forced vacuum and circuit drying

To obtain a forced vacuum in the chiller circuit it is necessary to have a specific pump with a high vacuum level capable of reaching at least 0.1mbar (absolute).

If a specific pump were not available or when a circuit has stayed open for a long time, it is strongly recommended to follow the triple evacuation method.

This method is also indicated if there is any moisture in the circuit.

The vacuum pump should be connected to the filler sockets.

Evacuate the circuit to an absolute pressure of at least 35 mbars; afterwards break the vacuum with anhydrous nitrogen.

Repeat the operation of the above point.

Repeat the operation of the above point for a third time, trying in this case to reach the greatest vacuum possible.

With this procedure it is possible to remove up to 99% of pollutants easily.

Refrigerant charge

Connect the refrigerant gas cylinder to the charging socket on the liquid line letting a little gas come out of the pipe to eliminate the air it contains.

Turn over the cylinder and charge it with liquid until 100% of the total charge has been introduced. Afterwards, check the sub-cooling value that has to be between 7 and 10°C.

11. PUTTING THE MACHINE OUT OF SERVICE

When the machine has reached the end of its life cycle, it must be disconnected from the electrical supply line and disinstalled from its working position.

The machine must be disposed of in full compliance with the waste disposal laws in the country where it is installed.

IMPORTANT! After removing the machine from its work station, affix a permanent notice to it with the message: "MACHINE FOR DISMANTLING, DO NOT USE".

12. SPARE PARTS

When ordering spare parts it is **always** necessary to specify:

1. All the data on the identification plate affixed to the machine (see Fig. 2 page 8);
2. The reference number and the code number of the part (see spare parts table);
3. The description of the part required;
4. The quantity required;
5. The exact destination address and means of dispatch required.

PIOVAN S.p.A. accepts no responsibility for mistaken consignments resulting from inaccurate or incomplete information.

13. ACCESSORIES

The entire range of CH chillers can be integrated with a set of optional extras making it possible to keep it working correctly. These chillers may come to work in anomalous conditions (process water with considerable debris, electric mains not very stable, etc.) that could undermine its working properly.

13.1. FILTERS

The water chillers in the CH series can be fitted out with filters for the inlet water. This accessory, (supplied loose) is helpful when the process water contains debris that, should it reach the chiller, could impair its operation. A cartridge filter is proposed with the following characteristics:

Chiller	IN-OUT connections	Filterable flow rate	Filtration grade
CH50-90	3/4" G	9.6 m3/h	60 µm
CH180-280	1" G	9.6 m3/h	60 µm
CH380-480	1"1/2 G	20 m3/h	60 µm

13.2. HOT GAS INJECTION BY-PASS VALVE

The purpose of the gas injection solenoid is to reduce the cooling capacity of the chiller when the temperature of the process fluid is near the set-point. In this way a reduction in the frequency with which the compressor switches ON and OFF is obtained and as a result also in the resulting fluctuations in the fluid leaving the compressor due to the minimum starting and stopping times set by the control thermostat (which are indispensable for preventing damage to the electrical motor); a similar result is obtained increasing the accumulation capacity in the hydraulic circuit.

The reduction in refrigerating power is obtained by reducing the quantity of gas that is rolled through the expansion valve diverting part of the gas from the compressor outlet directly into the evaporator. The compressor outlet and evaporator inlet are physically connected by a by-pass valve that may be open or shut by a (hot gas injection) solenoid valve controlled by the control thermostat. The calibration tap R is factory set to allow the chiller to work with the by-pass open up to a thermal load of not less than 30% of the maximum load the chiller can handle with the by-pass closed. See the the following diagram.

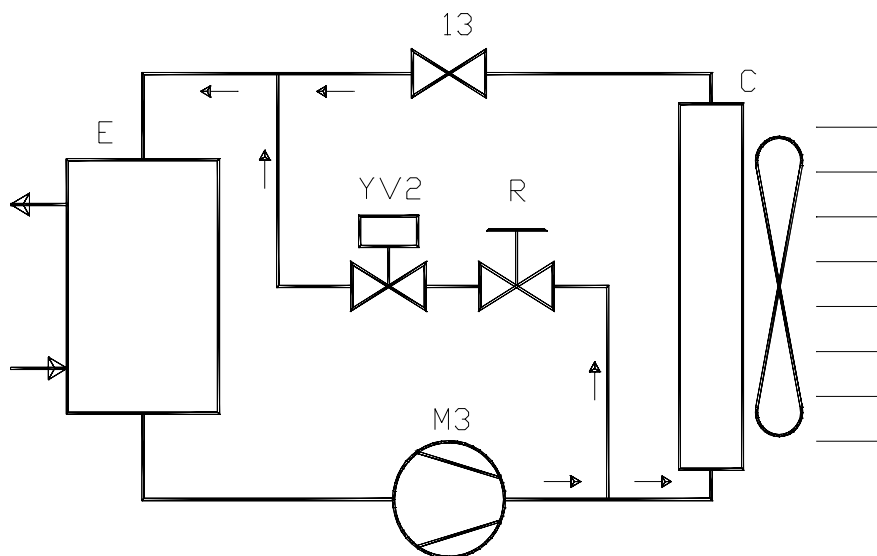

The following diagram gives the solenoid valve's operation when varying the temperature of the process fluid with respect to the setpoint.

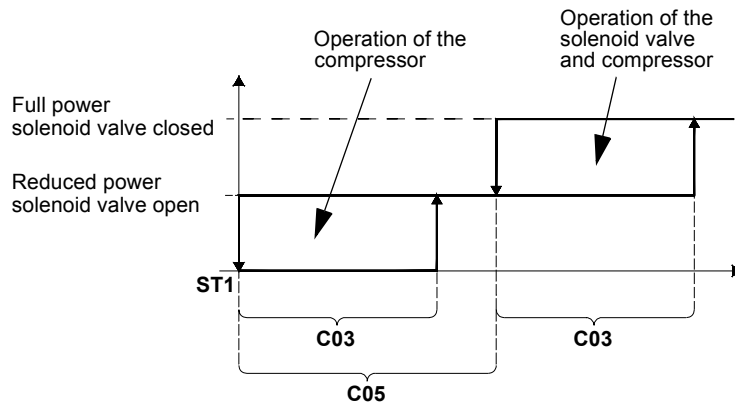

Fig. 12

13.3. CHECKING PHASE SEQUENCE AND VOLTAGE

The construction of scroll-type compressors requires keeping a strict direction of rotation. If the compressor is made to work for a long time in the opposite direction of rotation, besides not compressing the refrigerating gas, it can get severely damaged. To avoid this danger, it is possible to install a phase sequence control in the electric panel that will prevent the chiller starting if there is the wrong phase sequence. This control acts directly on the remote ON/OFF input of the thermostat, so if the sequence is wrong then "E00" is shown on the display and the HLO lamp on the front of the panel comes on.

If the alarm trips, it is necessary to cut off power to the machine with the main isolating switch and the switch upline from the chiller and then swap over two of the three wires coming into the isolating switch.

Once the system has been started up the phase sequence control stays active and checks for the line voltage lowering and/or one of the three phases failing (this is again to prevent damage to the electric motors). So, if during normal operation the chiller switches off, the thermostat shows "E00", and the signal lamp HLO (situated on the door of the panel) lights, it will be necessary to cut off power to the machine and check for any trouble with the electricity distribution line.

APPENDIX A. REFRIGERANT SAFETY SHEET

	R22	R134a	R407c
Name	chlorodifluoromethane	1,1,1,2 - tetrafluoroethane	23% Difluoromethane (R32); 25% Pentafluoroethane (R125) 52% R134a

Indication of dangers

Greatest dangers	Asphyxia		
Specific dangers	not known	not known	fast evaporation can cause freezing.

First aid

General information:	Do not administer anything to anyone who has fainted.
Inhalation:	Take out into the open air. Use oxygen or artificial respiration if necessary. Do not administer adrenalin or similar substances.
Contact with eyes:	Carefully rinse with plenty of water for at least 15 minutes and call a doctor.
Contact with the skin:	Wash immediately with plenty of water. Immediately take off any contaminated clothing.

Fire-fighting

Means of extinguishing:	Any.
Specific dangers:	Increase in pressure.
Specific methods:	Cool the containers by splashing water.

Action in case of accidental spillage

Individual precautions:	Evacuate personnel into safety areas. Make provision for adequate ventilation. Use individual safety gear.
Environmental precautions:	It evaporates.
Methods of cleaning:	It evaporates.

Handling

Technical measures/precautions:	Use solely in well-ventilated rooms.	Use solely in well-ventilated rooms.	Ensure sufficient air ventilation and/or extraction in the work environment.
advice for safe use:		Leak test. Never perform a pressure test with mixtures of air/R134a. It can form a mixture with air that is combustible at higher pressures than atmospheric pressure when the volume ratio exceeds 60%	

Storage

Storage:	Close carefully and keep in a cool, dry and well-ventilated place.	Close carefully and keep in a cool, dry and well-ventilated place.	Close carefully and keep in a cool, dry and well-ventilated place. Keep in its original containers. Incompatible products: explosive, flammable materials, organic peroxide
----------	--	--	---

Checking individual protection/exposure

Control parameters:	1000ppm,v/v,ml/m ³ =3540 mg/m ³ as a weighted average over 8 hours.	1000ppm,v/v,ml/m ³ =3540 mg/m ³ as a weighted average over 8 hours.	AEL (8-h e 12-h TWA)=1000 ml/m ³ for each of the three components.
Respiratory protection:	For rescues and maintenance work in tanks, use independent breathing apparatus. The fumes are heavier than air and can cause suffocation by reducing the oxygen available for breathing.		
Eye protection:	Safety goggles.		
Hand protection:	Rubber gloves.		
Hygiene measures:	No smoking.		

Physical and chemical properties

Colour:	Colourless.		
Smell:	Similar to ether.		
Boiling point:	-40.8°C at atm. press.	-26.5°C at atm. press.	-43.9°C at atm. press.
Flash point:	It is not flammable.		
Relative density:	1.194 kg/l at 25°C	1.21 kg/l at 25°C	1.138 kg/l at 25°C
Solubility in water:	3 g/l at 25°C and atm. press.	0.15% in weight (25°C and atm. press.)	Negligible.

Ecological information

Global heating potential HGWP (R11=1):	0.098	0.28	R125: 0.84 - R134a: 0.28
Ozone depletion potential ODP (R11=1):	0.05	0	0

Stability and reactivity

Stability:	No reactivity if used with the appropriate precautions.		
Materials to avoid:	Alkaline metals, ferrous alkaline metals, salts of granulated metal, Al, Zn, Be, etc. in powder form.		
Dangerous products of decomposition:	Halide acids, traces of carbonyl halides.		
Acute toxicity:	LC50/inhalation/4hours/on rat=220ml/l	ALC/inhalation/4hours/on rat=567ml/l	(R32) LC50/inhalation/4hours/on rat=760ml/l (R125) LC50/inhalation/4hours/on rat=3480 mg/l (R134a) ALC/inhalation/4hours/on rat=567ml/l
Local effects:	Concentrations substantially above 1000 ppm v/v can produce narcotic effects. Inhalation of products in decomposition at high concentration can breathing difficulties (pulmonary oedema).		Concentrations substantially above the TLV can produce narcotic effects. Inhalation of products in decomposition at high concentration can cause breathing difficulties (pulmonary oedema).
Long-term toxicity:	It has not shown any carcinogenic, teratogenic or mutagenic effects in experiments on animals.		

Remarks on disposal

It can be used with re-conditioning.

APPENDIX B. WATER SPECIFICATIONS SHEET

PIOVAN chillers need the process fluid to be water with the following characteristics (ref. UNI 8884):

Characteristic / magnitude	Amount
Appearance	Preferably clear and colourless. Undissolved substances, preferably absent.
PH	>7 (not acid)
Conductivity	≤ 3000 S/cm
STD	≤ 2000 mg/l at 180°
Total hardness	< 1000 mg/l CaCO ₃ for total alkalinity equal to zero (with alkalinity, correlate the temporary hardness, calcium hardness or alkalinity parameters with the most restrictive amount).
Temporary hardness	< 350 mg/l CaCO ₃ if the calcium hardness is equal to or greater than 350.
Calcium hardness	< 600 mg/l CaCO ₃ in general, 350 if the alkalinity is equal to or greater than 350.
Total alkalinity	≤ 450
Chlorides	< 1000 mg/l Cl
Silica	≤ 60 mg/l SiO ₂
Iron	≤ 1.5 mg/l Fe
Iron + Manganese	≤ 1.5 mg/l Fe + Mn
Organic substances	Absent
Dissolved gases	H ₂ S -----> absent Ammonia -----> absent Hydrocarbons -----> traces Oxygen and other gases ---> within the solubility limits
Oils and fatty substances	Absent

Using other process fluids than water with the above characteristics may lead to chemical or mechanical corrosion of the chiller components or to deposits forming on the heat exchange surfaces and generally on the surfaces of the parts in contact with the water that over time may lead to them bursting due to ice forming locally or an increase in the speed of the fluid due to a decrease in the cross-section of the passage.

APPENDIX C. TROUBLESHOOTING

ALARM	CAUSE	EFFECT	CORRECTIVE ACTION
E00 Machine OFF from remote control.	Digital input off.	Chiller fully turned off.	Close the remote control input.
E00 + HL0 (optional)	Wrong phase sequence or power supply voltage outside the permissible tolerances.	Chiller fully turned off.	If the alarm trips on the first start-up, swap over two phases directly downline from the main switch QS1. If tripping occurs during running, check the power supply voltage (it must not be beyond +/-10% of the data plate value)
E01 High-pressure alarm.	Machine panels open.	Compressor stops.	Close all the open panels. Reset the high-pressure switch SP2 and the alarm and restart the machine.
	Air filter and condenser fins dirty.		Clean the filters and condenser fins. Reset the high-pressure switch SP2 and the alarm and restart the machine.
	Front surface of the condenser obstructed.		Free the front surface of the condenser. Check the minimum permissible clearance between the chiller and walls and/or other appliances. Reset the high-pressure switch SP2 and the alarm and restart the machine.
	Possible fan(s) ducting obstructed or not correctly realized.		Check that the expulsion ducts are not obstructed. Verify that the sizing of the ducting conforms to the indications in this manual. Reset the high-pressure switch SP2 and the alarm and restart the machine.
	The fan does not work.		Check the fan motor. Verify that the contact of the control pressure switch SP1 closes on exceeding the pressure of *** bars (reading on the pressure gauge ***) Reset the high-pressure switch SP2 and the alarm and restart the machine.

	Ambient temperature too high.		Check that the temperature of the air extracted through the condenser is no greater than the maximum permissible value. (see "TECHNICAL DATA" on page 10). Take the ambient temperature to within the preset limits, e.g. Increasing the ventilation in the room. Change the position of the machine or the surrounding barriers to eliminate hot air recirculation. Reset the high-pressure switch SP2 and the alarm and restart the machine.
	Water temperature too high.		See alarm E46 Reset the high-pressure switch SP2 and the alarm and restart the machine.
	Heating load applied too high.		Reduce the heating load to within the pre-set values at the current working conditions (water and air temperatures). Reset the high-pressure switch SP2 and the alarm and restart the machine.
E02. High-pressure alarm	Refrigerant drainage system.	Compressor stops.	Have a chiller technician check for any leaks and eliminate them. Have the system filled by an expert chiller technician. Reset the alarm and restart the machine.
	Evaporator frozen.		Check the water circulates in the chiller correctly. See alarm E41. Wait for the evaporator to defreeze, reset the alarm and restart the machine.
	Gas circuit solenoid valve fails to open.		Check the solenoid valve control circuit. Check the control coil and replace it if necessary. Reset the alarm and restart the machine.
	Gas filter clogged.		Have a chiller technician check the filter and replace it if necessary. Reset the alarm and restart the machine.
E03 Compressor(s) protection	Heating load too high concurrently with high ambient temperatures.	Compressor stops.	Reduce the heating load to within the pre-set values at the current working conditions (water and air temperatures). Wait for a few minutes before restarting the machine. Reset the alarm and restart the machine.
	Heating load too high concurrently with discharged chiller circuit.		Have a chiller technician check for any leaks and eliminate them. Have the system filled by an expert chiller technician. Reduce the heating load to within the pre-set values at the current working conditions (water and air temperatures). Wait for a few minutes before restarting the machine. Reset the alarm and restart the machine.
E04. Fan(s) protection trips.	Fan motor power electrical input too high.	Fan(s) and compressor stop.	Check the voltage and see there are all three power supply phases. Check the current electrical input of the fan. Repair or replace the fan. Check the thermal protection of the fan, too. Reset the alarm and restart the machine.

E05. Anti-freeze alarm.	Evaporator outlet temperature too low.	Compressors stop.	Check whether the control circuit stops the compressor when the established set point is reached (for the machines not provided with hot gas by-pass option). Reset the alarm and restart the machine.
	Low water flow rate in the evaporator.		Check the differential pressure switch/flowmeter works properly and replace it if necessary. Open the water by-pass valve to increase the circulation in the evaporator. Reset the alarm and restart the machine.
	Evaporation pressure (temperature) too low.		Check the fan(s) works properly (in cold periods it must not work continuously, check the control circuit if necessary). Have a chiller technician check the expansion valve operation and setting. Reset the alarm and restart the machine.
E06 Anti-freeze probe fault	The anti-freeze probe BT2 is faulty.		Replace the probe. Reset the alarm and restart the machine.
	The anti-freeze probe BT2 is disconnected.		Check the probe's electrical connections. Reset the alarm and restart the machine.
E07 Fault at the condensation pressure analogue transducer (if the machine is installed for outside use).	The transducer BP3 is faulty.		Replace the transducer. Reset the alarm and restart the machine
	The transducer BP3 is disconnected.		Check the transducer's electrical connections. Reset the alarm and restart the machine.
E40 Process probe fault.	The probe BT1 is faulty.		Replace the probe. Reset the alarm and restart the machine.
	The probe BT1 is disconnected.		Check the probe's electrical connections. Reset the alarm and restart the machine.
E41 Differential pressure switch/flowmeter alarm	Poor water circulation.	Pump stops.	Check the delivery and return of the water circuit are not shut. Check that the applied service is not shut off. Open the water by-pass valve to increase the flow of water into the chiller. Reset the alarm and restart the machine.
	Water pre-charging pressure too low / machine drained of water.		Check that the water supply is not shut off and is connected to the filler valve; fill the circuit. Check for any leaks from the water circuit. Reset the alarm and restart the machine.
E46 Water temperatures too high	The water temperature has reached a value that is too high.	Compressor turned off.	Check the possible causes. Reduce the water temperature to normal values. Reset the alarm and restart the machine.
--- Machine at a total standstill.	Everything turned off		Check the switch, fuses, supply cable, electric mains and main switch.

<p>--- Low water flow rate to the service</p>	<p>The pump turns in the opposite direction.</p>		<p>Reverse the direction of rotation of the pump after checking that of the other motors.</p>
	<p>Water by-pass not set/ fully open.</p>		<p>Set the by-pass so as to obtain the highest possible flow rate but without tripping alarm E41: in which case, slightly reopen the by-pass.</p>
	<p>Piping obstructed or blocked.</p>		<p>Check all the pipes and the shut-off valves.</p>
	<p>Pressure drop too high.</p>		<p>Check the cross-sections and length of the water supply: refer to section 7.2.2. - pag. 24 of this manual for the minimum cross-sections. Increase the line diameter if necessary.</p>
<p>--- The chiller works continuously but the water temperature increases.</p>	<p>Low cooling capacity.</p>		<p>Check that the power delivered by the assembly (in relation to the current working conditions) is no lower than as required: if necessary, decrease the applied heating load and, if possible, decrease the air temperature by ventilating the room more. Have a chiller technician check for any refrigerant gas leaks and eliminate them. Have the system charge restored by an expert chiller technician.</p>

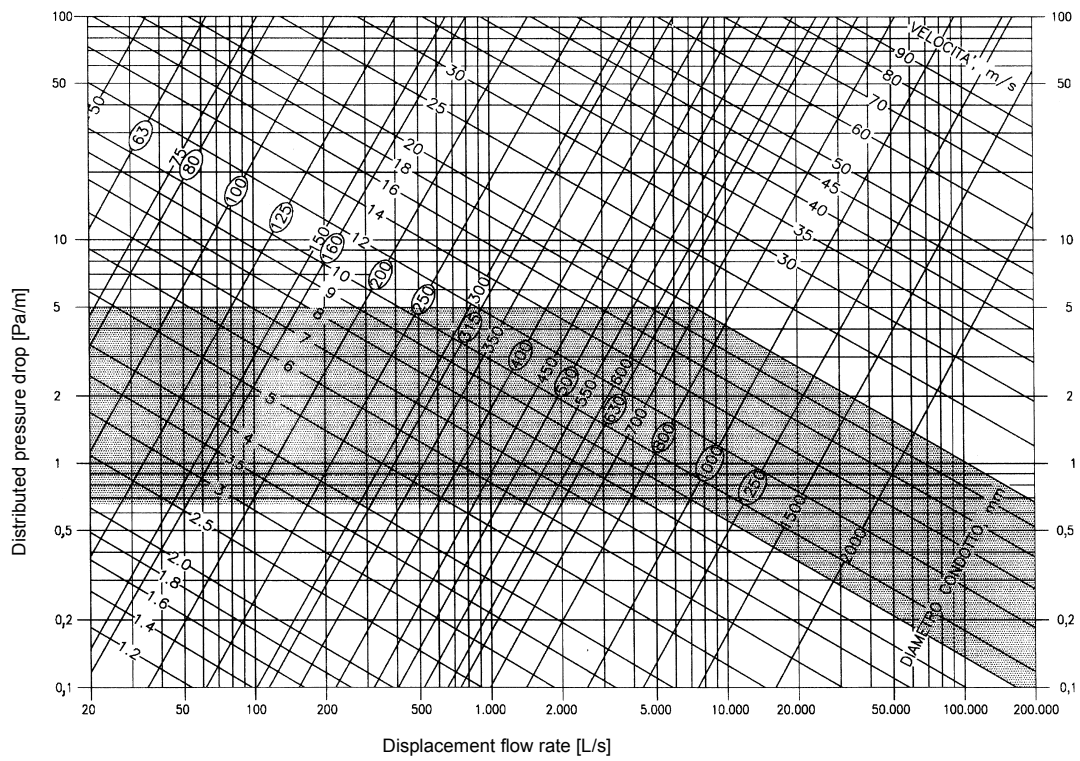

Fig. 13

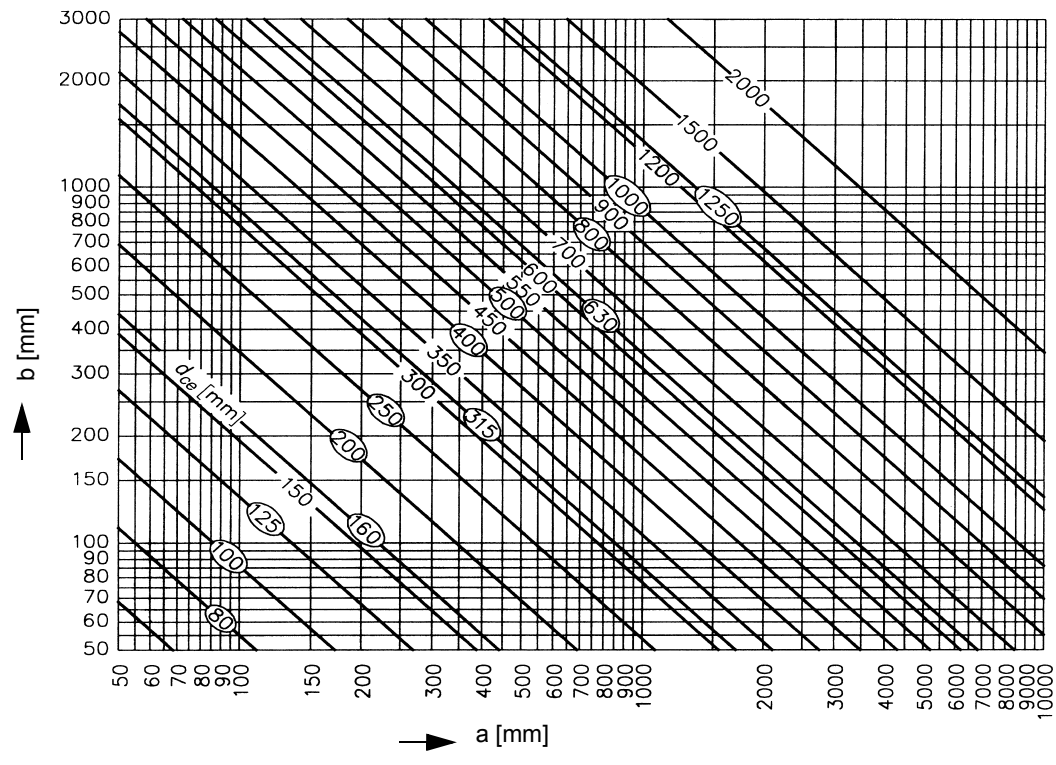

Fig. 14

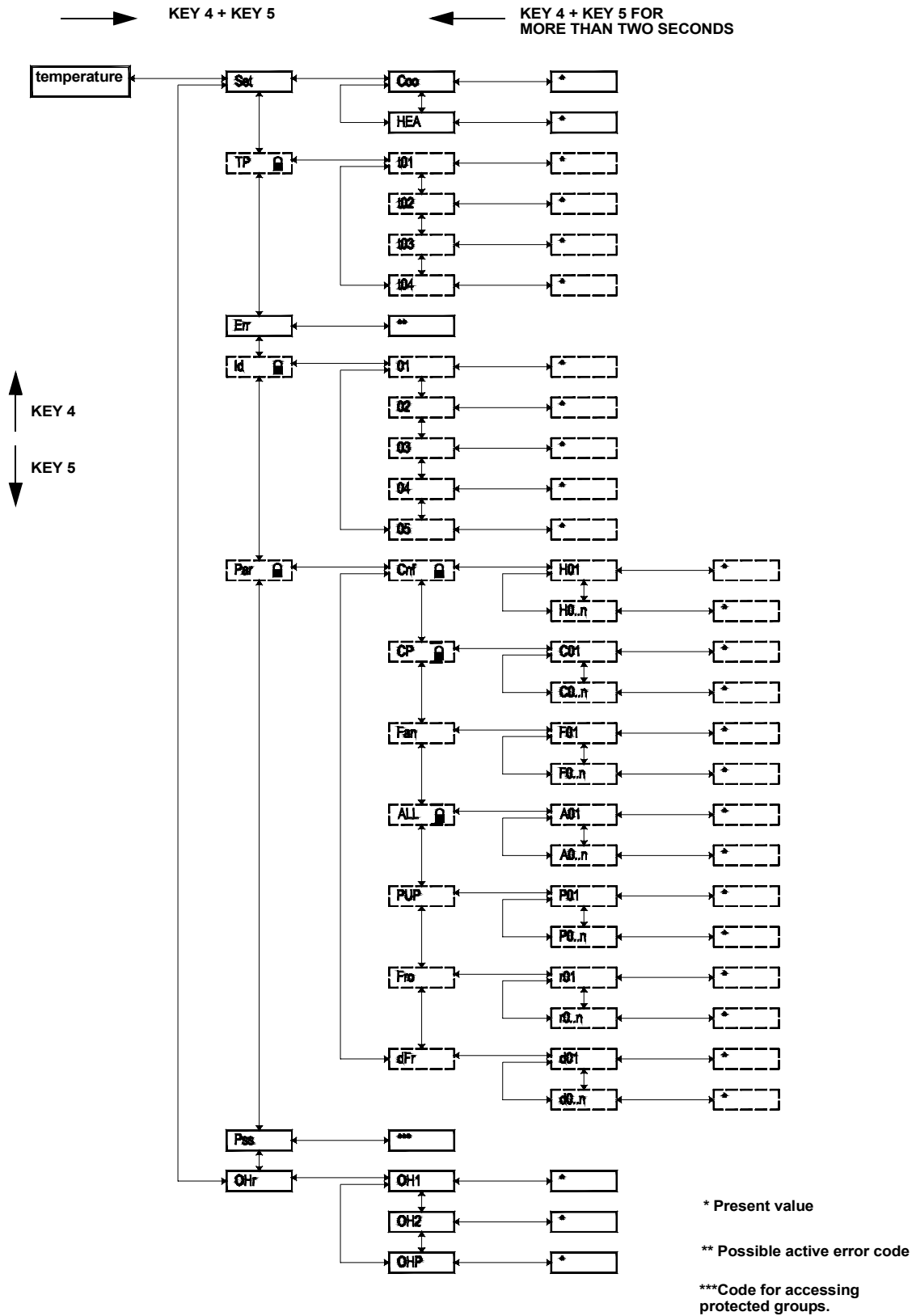
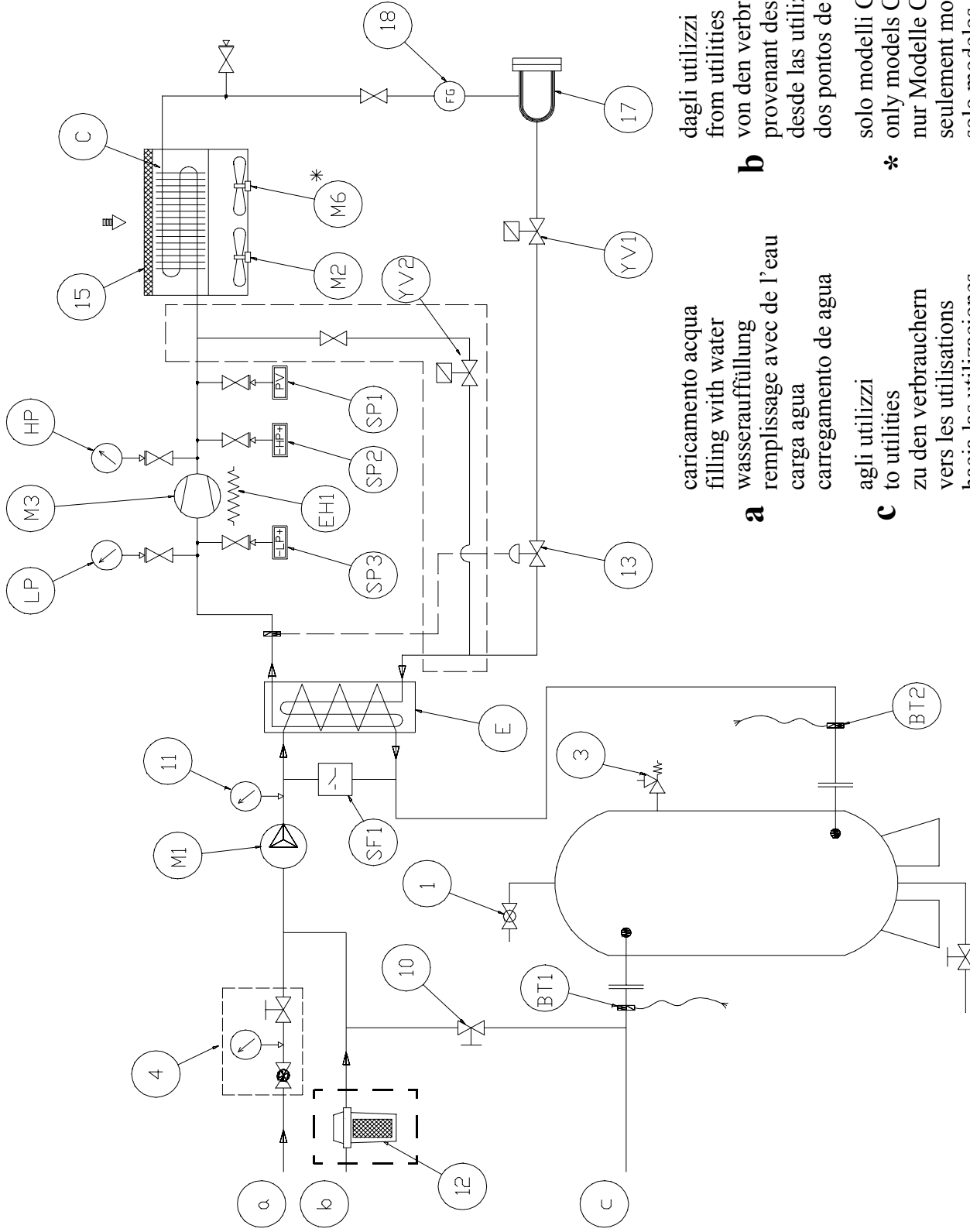

Fig. 15

TABELLE RICAMBI
TABLES OF SPARE PARTS
ERSATZTEILTABELLEN
TABLEAUX PIECES DE RECHANGE
TABLAS REPUESTOS
TABELA DAS PEÇAS DE REPOSIÇÃO



a caricamento acqua
filling with water
wasserauffüllung
remplissage avec de l'eau
carga agua
carregamento de agua

b dagli utilizzi
from utilities
von den verbrauchern
provenant des utilisations
desde las utilizaciones
dos pontos de utilização

c agli utilizzi
to utilities
zu den verbrauchern
vers les utilisations
hacia las utilizaciones
para os pontos de utilização

solo modelli CH380, CH480
only models CH380, CH480
nur Modelle CH380, CH480
seulement modèles CH380, CH480
solo modelos CH380, CH480
apenas modelos CH380, CH480

**PIOVAN**

ERSATZTEILTABELLE
TABELA DAS PEÇAS DE REPOSIÇÃO

TABLE OF SPARE PARTS
TABLA REPUESTOS

TAB. 1 TABELLA RICAMBI
TABEUAU PIECES DE RECHANGE

CH50

	Descrizione	Description	Beschreibung	Description	Description	Descripción	Descrição	400V/3/50Hz	460V/3/60Hz
1	Valvola sfiato automatica	Automatic vent valve	Automatisches Entlüftungsventil	Souape purge automatique	Válvula desfogue automática	Válvula desfogue automática	Válvula drenagem automática	4190601	
3	Valvola di sicurezza	Safety valve	Sicherheitsventil	Souape de sureté	Válvula de seguridad	Válvula de seguridad	Válvula de sugurança	4190635	
4	Valvola di caricamento acqua	Filling valve	Füllungsventil	Vanne de remplissage	Valvula de relleno	Valvula de relleno	Válvula carregamento.	4190603	
11	Manometro pressione mandata	Delivery pressure gauge	Manometer vorlaufdruck	Manomètre pression refoulement	Manómetro presión de impulsión	Manómetro presión de impulsión	Manómetro pressão alimentação	4150419	
13	Valvola di espansione termostatica	Thermostatic expansion valve	Thermostatisches Expansionsventil	Détendeur thermostatique	Válvula de expansión termostática	Válvula de expansión termostática	Válvula de expansão termostática	4190470	
15	Filtro aria	Air filter	Luftfilter	Filter air	Filtro aire	Filtro aire	Filtro do ar	-	
17	Filtro deidratatore	Dehydrator filter	Dehydrierungsfilter	Filter de déshydratation	Filtro deshidratator	Filtro deshidratator	Filtro desidratator	4240455	
18	Indicatore refrigerante	Coolant indicator	Kühmittelanzeige	Indicateur réfrigérant	Indicator refrigerante	Indicator refrigerante	Indicator do refrigerante	4190527	
BT1	Sonda temperatura processo	Process temperature probe	Prozestemperatursonde	Détecteur temperature processus	Sonda temperatura proceso	Sonda temperatura proceso	Sonda temperatura processo	4151258	
BT2	Sonda temperatura antigelo	Antifreeze temperature probe	Antifrost temperaturesonde	Détecteur température antigel	Sonda temperatura anticongelante	Sonda temperatura anticongelante	Sonda temperatura anticongelante	4151258	
C	Condensatore	Condenser	Kondensator	Condenseur	Condensador	Condensador	Condensador	610A1740	
E	Evaporatore	Evaporator	Verdampfer	Evaporateur	Evaporador	Evaporador	Evaporador	4280166	
EH1	Resistenza carter	Crankcase heater	Heizwiderstand gehäuse	Resistance carter	Resistencia cárter	Resistencia cárter	Resistencia cárter	4180654	
G	Refrigerante R22	Coolant R22	Kühmittel R22	Réfrigérant R22	Refrigerante R22	Refrigerante R22	Refrigerante R22	4210401	
	Refrigerante R407C	Coolant R407C	Kühmittel R407C	Réfrigérant R407C	Refrigerante R407C	Refrigerante R407C	Refrigerante R407C	4210405	
HP	Manometro alta pressione	High pressure gauge	Hochdruckmanometer	Manomètre haute pression	Manómetro alta presión	Manómetro alta presión	Manómetro alta pressão	4150411	



ERSATZTEILTABELLE
TABELA DAS PEÇAS DE REPOSIÇÃO

TABLE OF SPARE PARTS
TABLA REPUESTOS

TAB. 1 TABELLA RICAMBI
TABLEAU PIECES DE RECHANGE

CH50

	Descrizione	Description	Beschreibung	Description	Descripción	Descrição	400V/3/50Hz	460V/3/60Hz
LP	Manometro bassa pressione	Low pressure gauge	Niederdruckmanometer	Manomètre basse pression	Manómetro baja presión	Manómetro baixa pressão	4150410	
	Elettropompa (standard)	Electric pump (standard)	Elektropumpe (standard)	Electropompe (standard)	Electrobomba (standard)	Electrobomba (standard)	4181270	4181901
M1	Tenuta per elettropompa (standard)	Seal for electric pump (standard)	Abdichtung elektropumpe (standard)	Tenue pour électropompe (standard)	Estaqueidad para electrobomba (standard)	Vedante para electrobomba (standard)	4180489	
	Elettropompa (maggiorata)	Electric pump (enhanced)	Elektropumpe (größere)	Electropompe (majorée)	Electrobomba (sobredimensionada)	Electrobomba (potência maior)	4181970	4181973
M2	Tenuta per elettropompa (maggiorata)	Seal for electric pump (enhanced)	Abdichtung elektropumpe (größere)	Tenue pour électropompe (majorée)	Estaqueidad para electrobomba (sobredimensionada)	Vedante para electrobomba (potência maior)	4180480	
	Elettroventilatore	Electric fan	Elektroventilator	Ventilateur électrique	Electroventilador	Electroventilador	4170505	4170506
M3	Compressore (R22)	Compressor (R22)	Verdichter (R22)	Compresseur (R22)	Compresor (R22)	Compressor (R22)	4181572	4181591
	Compressore (R407C)	Compressor (R407C)	Verdichter (R407C)	Compresseur (R407C)	Compresor (R407C)	Compressor (R407C)	4181709	4181750
SF1	Pressostato differenziale	Differential pressure switch	Differential druckmesser	Pressostat différentiel	Presóstato diferencial	Pressostato differenziale	4152026	
SP1	Pressostato ventilatore	Fan pressure switch	Druckwächter ventilator	Pressostat ventilateur	Presóstato ventilador	Pressostato ventilador	4152038	
SP2	Pressostato di alta pressione	high pressure switch	Druckwächter hoher druck	Pressostat de haute pression	Presóstato de alta presión	Pressostato de alta pressão	4152053	
SP3	Pressostato di bassa pressione	low pressure switch	Druckwächter niedriger druck	Pressostat de basse pression	Presóstato de baja presión	Pressostato de baixa pressão	4152040	
	Elettrovalvola	Solenoid valve	Magnetventil	Electrovanne	Electroválvula	Electroválvula	4551222	
YV1	Bobina	Coil	Spule	Bobine	Bobina	Bobina	4551057	
	Elettrovalvola	Solenoid valve	Magnetventil	Electrovanne	Electroválvula	Electroválvula	4551227	
YV2	Bobina	Coil	Spule	Bobine	Bobina	Bobina	4551057	

**PIOVAN**

TAB. 1 **TABELLA RICAMBI** **TABLE OF SPARE PARTS** **ERSATZTEILTABELLE**
TABLEAU PIECES DE RECHANGE **TABLA REPUESTOS** **TABELA DAS PEÇAS DE REPOSIÇÃO**

CH50

Descrizione	Description	Beschreibung	Description	Descripción	Descrição	400V/3/50Hz	460V/3/60Hz
Oilio compressore R22	Oil for compressor	Öl fuer Verdichter	Huile compresseur	Aceite compresor	Óleo compressor	4210228	
Oilio compressore R407C	Oil for compressor	Öl fuer Verdichter	Huile compresseur	Aceite compresor	Óleo compressor	4210226	
Filtro acqua completo di cartuccia	Water complete cartridge	Wasserfilter komplett mit Papierfilter	Filtre eau avec cartouche	Filtro de agua completo cartucho	Filtro água completo com elemento	4240460	
Cartuccia filtro acqua	Cartridge for water filter	Wasserpapierfilter	Cartouche filtre eau	Cartucho filtro agua	Elemento filtro de água	4240471	

TAB. 2 TABELLA RICAMBI

TABLE OF SPARE PARTS

ERSATZTEILTABELLE



PIOVAN

TABLEAU PIECES DE RECHANGE

TABLA REPUESTOS

TABELA DAS PEÇAS DE REPOSIÇÃO

CH90

	Descrizione	Description	Beschreibung	Description	Description	Descripción	Descrição	400V/3/50Hz	460V/3/60Hz
1	Valvola sfiato automatica	Automatic vent valve	Automatisches Entlüftungsventil	Soupepe purge automatique	Válvula desfogue automática	Válvula drenagem automática	Válvula de drenagem automática	4190601	
3	Valvola di sicurezza	Safety valve	Sicherheitsventil	Soupepe de sureté	Válvula de seguridad	Válvula de segurança	Válvula de segurança	4190635	
4	Valvola di caricamento acqua	Filling valve	Füllungsventil	Vanne de remplissage	Valvula de relleno	Valvula carregamento.	Valvula carregamento.	4190603	
11	Manometro pressione mandata	Delivery pressure gauge	Manometer vorlaufdruck	Manomètre pression refoulement	Manómetro presión de impulsión	Manómetro pressão alimentação	Manómetro pressão alimentação	4150419	
13	Valvola di espansione termostatica	Thermostatic expansion valve	Thermostatisches Expansionsventil	Détendeur thermostatique	Válvula de expansión termostática	Válvula de expansão termostática	Válvula de expansão termostática	4190469	
15	Filtro aria	Air filter	Luftfilter	Filter air	Filtro aire	Filtro do ar	Filtro do ar	-	
17	Filtro deidratatore	Dehydrator filter	Dehydrierungsfilter	Filter de déshydratation	Filtro deshidratador	Filtro desidratador	Filtro desidratador	4240455	
18	Indicatore refrigerante	Coolant indicator	Kühmittelanzeige	Indicateur réfrigérant	Indicator refrigerante	Indicator do refrigerante	Indicator do refrigerante	4190527	
BT1	Sonda temperatura processo	Process temperature probe	Prozess temperature sonde	Détecteur temperature processus	Sonda temperatura proceso	Sonda temperatura processo	Sonda temperatura processo	4151258	
BT2	Sonda temperatura antigelo	Antifreeze temperature probe	Antifrost temperature sonde	Détecteur température antigel	Sonda temperatura anticongelante	Sonda temperatura anticongelante	Sonda temperatura anticongelante	4151258	
C	Condensatore	Condenser	Kondensator	Condenseur	Condensador	Condensador	Condensador	610A1340	
E	Evaporatore	Evaporator	Verdampfer	Evaporateur	Evaporador	Evaporador	Evaporador	4280167	
EH1	Resistenza carter	Crankcase heater	Heizwiderstand gehäuse	Resistance carter	Resistencia cárter	Resistencia cárter	Resistencia cárter	4180654	
G	Refrigerante R22	Coolant R22	Kühmittel R22	Réfrigérant R22	Refrigerante R22	Refrigerante R22	Refrigerante R22	4210401	
	Refrigerante R407C	Coolant R407C	Kühmittel R407C	Réfrigérant R407C	Refrigerante R407C	Refrigerante R407C	Refrigerante R407C	4210405	
HP	Manometro alta pressione	High pressure gauge	Hochdruckmanometer	Manomètre haute pression	Manómetro alta presión	Manómetro alta presión	Manómetro alta presión	4150411	



ERSATZTEILTABELLE

TABELA DAS PEÇAS DE REPOSIÇÃO

TABLE OF SPARE PARTS

TABELLA RICAMBI

TABLA REPUESTOS

TABLEAU PIECES DE RECHANGE

CH90

	Descrizione	Description	Beschreibung	Description	Descripción	Descrição	400V/3/50Hz	460V/3/60Hz
LP	Manometro bassa pressione	Low pressure gauge	Niederdruckmanometer	Manomètre basse pression	Manómetro baja presión	Manómetro baixa pressão	4150410	
	Elettropompa (standard)	Electric pump (standard)	Elektropumpe (standard)	Electropompe (standard)	Electrobomba (standard)	Electrobomba (standard)	4181270	4181901
M1	Tenuta per elettropompa (standard)	Seal for electric pump (standard)	Abdichtung elektropumpe (standard)	Tenue pour électropompe (standard)	Estaqueidad para electrobomba (standard)	Vedante para electrobomba (standard)	4180489	
	Elettropompa (maggiorata)	Electric pump (enhanced)	Elektropumpe (größere)	Electropompe (majorée)	Electrobomba (sobredimensionada)	Electrobomba (potência maior)	4181970	4181973
M2	Tenuta per elettropompa (maggiorata)	Seal for electric pump (enhanced)	Abdichtung elektropumpe (größere)	Tenue pour électropompe (majorée)	Estaqueidad para electrobomba (sobredimensionada)	Vedante para electrobomba (potência maior)	4180480	
	Elettroventilatore	Electric fan	Elektroventilator	Ventilateur électrique	Electroventilador	Electroventilador	4170505	4170506
M3	Compressore (R22)	Compressor (R22)	Verdichter (R22)	Compresseur (R22)	Compresor (R22)	Compressor (R22)	4181573	4181588
	Compressore (R407C)	Compressor (R407C)	Verdichter (R407C)	Compresseur (R407C)	Compresor (R407C)	Compressor (R407C)	4181710	4181753
SF1	Pressostato differenziale	Differential pressure switch	Differential druckmesser	Pressostat différentiel	Presóstato diferencial	Pressostato differenziale	4152026	
SP1	Pressostato ventilatore	Fan pressure switch	Druckwächter ventilator	Pressostat ventilateur	Presóstato ventilador	Pressostato ventilador	4152038	
SP2	Pressostato di alta pressione	high pressure switch	Druckwächter hoher druck	Pressostat de haute pression	Presóstato de alta presión	Pressostato de alta pressão	4152053	
SP3	Pressostato di bassa pressione	low pressure switch	Druckwächter niedriger druck	Pressostat de basse pression	Presóstato de baja presión	Pressostato de baixa pressão	4152040	
	Elettrovalvola	Solenoid valve	Magnetventil	Electrovanne	Electroválvula	Electroválvula	4551222	
YV1	Bobina	Coil	Spule	Bobine	Bobina	Bobina	4551057	
	Elettrovalvola	Solenoid valve	Magnetventil	Electrovanne	Electroválvula	Electroválvula	4551227	
YV2	Bobina	Coil	Spule	Bobine	Bobina	Bobina	4551057	

**PIOVAN**

TAB. 2 **TABELLA RICAMBI** **TABLE OF SPARE PARTS** **ERSATZTEILTABELLE**
TABLEAU PIECES DE RECHANGE **TABLA REPUESTOS** **TABELA DAS PEÇAS DE REPOSIÇÃO**

CH90

Descrizione	Description	Beschreibung	Description	Descripción	Descrição	400V/3/50Hz	460V/3/60Hz
Oilio compressore R22	Oil for compressor	Öl fuer Verdichter	Huile compresseur	Aceite compresor	Óleo compressor	4210228	
Oilio compressore R407C	Oil for compressor	Öl fuer Verdichter	Huile compresseur	Aceite compresor	Óleo compressor	4210226	
Filtro acqua completo di cartuccia	Water complete cartridge	Wasserfilter komplett mit Papierfilter	Filtre eau avec cartouche	Filtro de agua completo de cartucho	Filtro água completo com elemento	4240460	
Cartuccia filtro acqua	Cartridge for water filter	Wasserpapierfilter	Cartouche filtre eau	Cartucho filtro agua	Elemento filtro de água	4240471	

TAB. 3 TABELLA RICAMBI

TABLE OF SPARE PARTS

ERSATZTEILTABELLE



PIOVAN

TABLEAU PIECES DE RECHANGE

TABLA REPUESTOS

TABELA DAS PEÇAS DE REPOSIÇÃO

CH180

	Descrizione	Description	Beschreibung	Description	Description	Descripción	Descrição	400V/3/50Hz	460V/3/60Hz
1	Valvola sfiato automatica	Automatic vent valve	Automatisches Entlüftungsventil	Souape purge automatique	Válvula desfogue automática	Válvula drenagem automática	Válvula de drenagem automática	4190601	
3	Valvola di sicurezza	Safety valve	Sicherheitsventil	Souape de sureté	Válvula de seguridad	Válvula de segurança	Válvula de segurança	4190635	
4	Valvola di caricamento acqua	Filling valve	Füllungsventil	Vanne de remplissage	Valvula de relleno	Valvula de carregamento.	Valvula de carregamento.	4190603	
11	Manometro pressione mandata	Delivery pressure gauge	Manometer vorlaufdruck	Manomètre pression refoulement	Manómetro presión de impulsión	Manómetro pressão alimentação	Manómetro pressão alimentação	4150419	
13	Valvola di espansione termostatica	Thermostatic expansion valve	Thermostatisches Expansionsventil	Détendeur thermostatique	Válvula de expansión termostática	Válvula de expansão termostática	Válvula de expansão termostática	4190468	
15	Filtro aria	Air filter	Luftfilter	Filter air	Filtro aire	Filtro do ar	Filtro do ar	4240262	
17	Filtro deidratatore	Dehydrator filter	Dehydrierungsfilter	Filter de déshydratation	Filtro deshidratador	Filtro desidratador	Filtro desidratador	4240456	
18	Indicatore refrigerante	Coolant indicator	Kühmittelanzeige	Indicateur réfrigérant	Indicador refrigerante	Indicador do refrigerante	Indicador do refrigerante	4190511	
BT1	Sonda temperatura processo	Process temperature probe	Prozess temperature sonde	Détecteur temperature processus	Sonda temperatura proceso	Sonda temperatura processo	Sonda temperatura processo	4151258	
BT2	Sonda temperatura antigelo	Antifreeze temperature probe	Antifrost temperature sonde	Détecteur température antigel	Sonda temperatura anticongelante	Sonda temperatura anticongelante	Sonda temperatura anticongelante	4151258	
C	Condensatore	Condenser	Kondensator	Condenseur	Condensador	Condensador	Condensador	610A1750	
E	Evaporatore	Evaporator	Verdampfer	Evaporateur	Evaporador	Evaporador	Evaporador	4280168	
EH1	Resistenza carter	Crankcase heater	Heizwiderstand gehäuse	Resistance carter	Resistencia cárter	Resistencia cárter	Resistencia cárter	4180654	
G	Refrigerante R22	Coolant R22	Kühmittel R22	Réfrigérant R22	Refrigerante R22	Refrigerante R22	Refrigerante R22	4210401	
	Refrigerante R407C	Coolant R407C	Kühmittel R407C	Réfrigérant R407C	Refrigerante R407C	Refrigerante R407C	Refrigerante R407C	4210405	
HP	Manometro alta pressione	High pressure gauge	Hochdruckmanometer	Manomètre haute pression	Manómetro alta presión	Manómetro alta presión	Manómetro alta presión	4150411	



ERSATZTEILTABELLE
TABELA DAS PEÇAS DE REPOSIÇÃO

TABLE OF SPARE PARTS
TABLA REPUESTOS

TAB. 3 TABELLA RICAMBI
TABLEAU PIECES DE RECHANGE

CH180

	Descrizione	Description	Beschreibung	Description	Descripción	Descrição	400V/3/50Hz	460V/3/60Hz
LP	Manometro bassa pressione	Low pressure gauge	Niederdruckmanometer	Manomètre basse pression	Manómetro baja presión	Manómetro baixa pressão	4150410	
	Elettropompa (standard)	Electric pump (standard)	Elektropumpe (standard)	Electropompe (standard)	Electrobomba (standard)	Electrobomba (standard)	4181967	4181902
M1	Tenuta per elettropompa (standard)	Seal for electric pump (standard)	Abdichtung elektropumpe (standard)	Tenue pour électropompe (standard)	Estaqueidad para electrobomba (standard)	Vedante para electrobomba (standard)	4180480	4180472
	Elettropompa (maggiorata)	Electric pump (enhanced)	Elektropumpe (größere)	Electropompe (majorée)	Electrobomba (sobredimensionada)	Electrobomba (potência maior)	4181970	4181973
M2	Tenuta per elettropompa (maggiorata)	Seal for electric pump (enhanced)	Abdichtung elektropumpe (größere)	Tenue pour électropompe (majorée)	Estaqueidad para electrobomba (sobredimensionada)	Vedante para electrobomba (potência maior)	4180480	
	Elettroventilatore	Electric fan	Elektroventilator	Ventilateur électrique	Electroventilador	Electroventilador	4170423	4170478
M3	Compressore (R22)	Compressor (R22)	Verdichter (R22)	Compresseur (R22)	Compresor (R22)	Compressor (R22)	4181574	4181589
	Compressore (R407C)	Compressor (R407C)	Verdichter (R407C)	Compresseur (R407C)	Compresor (R407C)	Compressor (R407C)	4181711	4181777
SF1	Pressostato differenziale	Differential pressure switch	Differential druckmesser	Pressostat différentiel	Presóstato diferencial	Pressostato differenziale	4152026	
SP1	Pressostato ventilatore	Fan pressure switch	Druckwächter ventilator	Pressostat ventilateur	Presóstato ventilador	Pressostato ventilador	4152038	
SP2	Pressostato di alta pressione	high pressure switch	Druckwächter hoher druck	Pressostat de haute pression	Presóstato de alta presión	Pressostato de alta presión	4152053	
SP3	Pressostato di bassa pressione	low pressure switch	Druckwächter niedriger druck	Pressostat de basse pression	Presóstato de baja presión	Pressostato de baixa pressão	4152040	
	Elettrovalvola	Solenoid valve	Magnetventil	Electrovanne	Electroválvula	Electroválvula	4551221	
YV1	Bobina	Coil	Spule	Bobine	Bobina	Bobina	4551057	
	Elettrovalvola	Solenoid valve	Magnetventil	Electrovanne	Electroválvula	Electroválvula	4551227	
YV2	Bobina	Coil	Spule	Bobine	Bobina	Bobina	4551057	

TAB. 3 TABELLA RICAMBI

TABLE OF SPARE PARTS

ERSATZTEILTABELLE



PIOVAN

TABLEAU PIECES DE RECHANGE

TABLA REPUESTOS

TABELA DAS PEÇAS DE REPOSIÇÃO

CH180

Descrizione	Description	Beschreibung	Description	Descripción	Descrição	400V/3/50Hz	460V/3/60Hz
Olío compressore R22	Oil for compressor	Öl fuer Verdichter	Huile compresseur	Aceite compresor	Óleo compressor	4210228	
Olío compressore R407C	Oil for compressor	Öl fuer Verdichter	Huile compresseur	Aceite compresor	Óleo compressor	4210226	
Filtro acqua completo di cartuccia	Water complete cartridge	Wasserfilter komplett mit Papierfilter	Filtre eau avec cartouche	Filtro de agua completo de cartucho	Filtro água completo com elemento	4240459	
Cartuccia filtro acqua	Cartridge for water filter	Wasserpapierfilter	Cartouche filtre eau	Cartucho filtro agua	Elemento filtro de água	4240473	

TAB. 4 TABELLA RICAMBI

TABLE OF SPARE PARTS

ERSATZTEILTABELLE

TABLEAU PIECES DE RECHANGE

TABLA REPUESTOS

TABELA DAS PEÇAS DE REPOSIÇÃO



CH280

	Descrizione	Description	Beschreibung	Description	Description	Descripción	Descrição	400V/3/50Hz	380V/3/60Hz	460V/3/60Hz
1	Valvola sfiato automatica	Automatic vent valve	Automatisches Entlüftungsventil	Souape purge automatique	Válvula desfogue automática	Válvula desfogue automática	Válvula drenagem automática		4190601	
3	Valvola di sicurezza	Safety valve	Sicherheitsventil	Souape de sureté	Válvula de seguridad	Válvula de seguridad	Válvula de sugurança		4190635	
4	Valvola di caricamento acqua	Filling valve	Füllungsventil	Vanne de remplissage	Valvula de relleno	Valvula de relleno de	Valvula carregamento.		4190603	
11	Manometro pressione mandata	Delivery pressure gauge	Manometer vorlaufdruck	Manomètre pression refoulement	Manómetro presión de impulsión	Manómetro presión de impulsión	Manómetro pressão alimentação		4150419	
13	Valvola di espansione termostatica	Thermostatic expansion valve	Thermostatisches Expansionsventil	Détendeur thermostatique	Válvula de expansión termostática	Válvula de expansión termostática	Válvula de expansão termostática		4190467	
15	Filtro aria	Air filter	Luftfilter	Filter air	Filtro aire	Filtro aire	Filtro do ar		4240267	
17	Filtro deidratatore	Dehydrator filter	Dehydrierungsfilter	Filter de déshydratation	Filtro deshidratador	Filtro deshidratador	Filtro desidratador		4240409	
18	Indicatore refrigerante	Coolant indicator	Kühmittelanzeige	Indicateur réfrigérant	Indicator refrigerante	Indicator refrigerante	Indicator do refrigerante		4190510	
BT1	Sonda temperatura processo	Process temperature probe	Prozestemperatursonde	Détecteur température processus	Sonda temperatura proceso	Sonda temperatura proceso	Sonda temperatura processo		4151258	
BT2	Sonda temperatura antigelo	Antifreeze temperature probe	Antifrost temperaturesonde	Détecteur température antigel	Sonda temperatura anticongelante	Sonda temperatura anticongelante	Sonda temperatura anticongelante		4151258	
C	Condensatore	Condenser	Kondensator	Condenseur	Condensador	Condensador	Condensador		610A2420	
E	Evaporatore	Evaporator	Verdampfer	Evaporateur	Evaporador	Evaporador	Evaporador		4280157	
EH1	Resistenza carter	Crankcase heater	Heizwiderstand gehäuse	Resistance carter	Resistencia cárter	Resistencia cárter	Resistencia cárter		4180650	
G	Refrigerante R22	Coolant R22	Kühmittel R22	Réfrigérant R22	Refrigerante R22	Refrigerante R22	Refrigerante R22		4210401	
	Refrigerante R407C	Coolant R407C	Kühmittel R407C	Réfrigérant R407C	Refrigerante R407C	Refrigerante R407C	Refrigerante R407C		4210405	
HP	Manometro alta pressione	High pressure gauge	Hochdruckmanometer	Manomètre haute pression	Manómetro alta presión	Manómetro alta presión	Manómetro alta pressão		4150411	

TAB. 4 TABELLA RICAMBI

TABLE OF SPARE PARTS

ERSATZTEILTABELLE



PIOVAN

TABLEAU PIECES DE RECHANGE

TABLA REPUESTOS

TABELA DAS PEÇAS DE REPOSIÇÃO

CH280

	Descrizione	Description	Beschreibung	Description	Descripción	Descrição	400V/3/50Hz	380V/3/60Hz	460V/3/60Hz
LP	Manometro bassa pressione	Low pressure gauge	Niederdruckmanometer	Manomètre basse pression	Manómetro baja presión	Manómetro baixa pressão	4150410		
	Elettropompa (standard)	Electric pump (standard)	Elektropumpe (standard)	Electropompe (standard)	Electrobomba (standard)	Electrobomba (standard)	4181968	4181913	4181903
M1	Tenuta per elettropompa (standard)	Seal for electric pump (standard)	Abdichtung elektropumpe (standard)	Tenue pour électropompe (standard)	Estaqueidad para electrobomba (standard)	Vedante para electrobomba (standard)	4180480		4180489
	Elettropompa (maggiorata)	Electric pump (enhanced)	Elektropumpe (größere)	Electropompe (majorée)	Electrobomba (sobredimensionada)	Electrobomba (potência maior)	4181295	4181916	4181296
M2	Tenuta per elettropompa (maggiorata)	Seal for electric pump (enhanced)	Abdichtung elektropumpe (größere)	Tenue pour électropompe (majorée)	Estaqueidad para electrobomba (sobredimensionada)	Vedante para electrobomba (potência maior)		4180480	
	Elettroventilatore	Electric fan	Elektroventilator	Ventilateur électrique	Electroventilador	Electroventilador	4170423	4170471	4170478
M3	Compressore (R22)	Compressor (R22)	Verdichter (R22)	Compresseur (R22)	Compresor (R22)	Compressor (R22)	4181720	4181721	4181722
	Compressore (R407C)	Compressor (R407C)	Verdichter (R407C)	Compresseur (R407C)	Compresor (R407C)	Compressor (R407C)	4181740	4181743	4181744
SF1	Pressostato differenziale	Differential pressure switch	Differential druckmesser	Pressostat différentiel	Presóstato diferencial	Pressostato differenziale		4152026	
SP1	Pressostato ventilatore	Fan pressure switch	Druckwächter ventilator	Pressostat ventilateur	Presóstato ventilador	Pressostato ventilador		4152038	
SP2	Pressostato di alta pressione	high pressure switch	Druckwächter hoher druck	Pressostat de haute pression	Presóstato de alta presión	Pressostato de alta pressão		4152053	
SP3	Pressostato di bassa pressione	low pressure switch	Druckwächter niedriger druck	Pressostat de basse pression	Presóstato de baja presión	Pressostato de baixa pressão		4152040	
	Elettrovalvola	Solenoid valve	Magnetventil	Electrovanne	Electroválvula	Electroválvula		4551221	
YV1	Bobina	Coil	Spule	Bobine	Bobina	Bobina		4551057	
	Elettrovalvola	Solenoid valve	Magnetventil	Electrovanne	Electroválvula	Electroválvula		4551227	
YV2	Bobina	Coil	Spule	Bobine	Bobina	Bobina		4551057	

TAB. 4 TABELLA RICAMBI

TABLE OF SPARE PARTS

ERSATZTEILTABELLE



PIOVAN

TABEAU PIECES DE RECHANGE

TABLA REPUESTOS

TABELA DAS PEÇAS DE REPOSIÇÃO

CH280

Descrizione	Description	Beschreibung	Description	Descripción	Descrição	400V/3/50Hz	380V/3/60Hz	460V/3/60Hz
Oilio compressore R22	Oil for compressor	Öl fuer Verdichter	Huile compresseur	Aceite compresor	Óleo compresor		4210228	
Oilio compressore R407C	Oil for compressor	Öl fuer Verdichter	Huile compresseur	Aceite compresor	Óleo compresor		4210226	
Filtro acqua completo di cartuccia	Water complete cartridge filter with	Wasserfilter komplett mit Papierfilter	Filtre eau avec cartouche	Filtro de agua completo de cartucho	Filtro água completo com elemento		4240459	
Cartuccia filtro acqua	Cartridge for water filter	Wasserpapierfilter	Cartouche filtre eau	Cartucho filtro agua	Elemento filtro de água		4240473	

TAB. 5 TABELLA RICAMBI

TABLE OF SPARE PARTS

ERSATZTEILTABELLE

TABLEAU PIECES DE RECHANGE

TABLA REPUESTOS

TABELA DAS PEÇAS DE REPOSIÇÃO



CH380

	Descrizione	Description	Beschreibung	Description	Description	Descripción	Descrição	400V/3/50Hz	380V/3/60Hz	460V/3/60Hz
1	Valvola sfiato automatica	Automatic vent valve	Automatisches Entlüftungsventil	Souape purge automatique	Válvula desfogue automática	Válvula desfogue automática	Válvula drenagem automática		4190601	
3	Valvola di sicurezza	Safety valve	Sicherheitsventil	Souape de sureté	Válvula de seguridad	Válvula de seguridad	Válvula de sugurança		4190635	
4	Valvola di caricamento acqua	Filling valve	Füllungsventil	Vanne de remplissage	Valvula de relleno	Valvula de relleno de	Valvula carregamento.		4190603	
11	Manometro pressione mandata	Delivery pressure gauge	Manometer vorlaufdruck	Manomètre pression refoulement	Manómetro presión de impulsión	Manómetro presión de impulsión	Manómetro pressão alimentação		4150419	
13	Valvola di espansione termostatica	Thermostatic expansion valve	Thermostatisches Expansionsventil	Détendeur thermostatique	Válvula de expansión termostática	Válvula de expansión termostática	Válvula de expansão termostática		4190466	
15	Filtro aria	Air filter	Luftfilter	Filter air	Filtro aire	Filtro aire	Filtro do ar		4240267	
17	Filtro deidratatore	Dehydrator filter	Dehydrierungsfilter	Filter de déshydratation	Filtro deshidratador	Filtro deshidratador	Filtro desidratador		4240457	
18	Indicatore refrigerante	Coolant indicator	Kühmittelanzeige	Indicateur réfrigérant	Indicator refrigerante	Indicator refrigerante	Indicator do refrigerante		4190528	
BT1	Sonda temperatura processo	Process temperature probe	Prozestemperatursonde	Détecteur température processus	Sonda temperatura proceso	Sonda temperatura proceso	Sonda temperatura processo		4151258	
BT2	Sonda temperatura antigelo	Antifreeze temperature probe	Antifrost temperaturesonde	Détecteur température antigel	Sonda temperatura anticongelante	Sonda temperatura anticongelante	Sonda temperatura anticongelante		4151258	
C	Condensatore	Condenser	Kondensator	Condenseur	Condensador	Condensador	Condensador		610A1760	
E	Evaporatore	Evaporator	Verdampfer	Evaporateur	Evaporador	Evaporador	Evaporador		4280158	
EH1	Resistenza carter	Crankcase heater	Heizwiderstand gehäuse	Resistance carter	Resistencia cárter	Resistencia cárter	Resistencia cárter		4180650	
G	Refrigerante R22	Coolant R22	Kühmittel R22	Réfrigérant R22	Refrigerante R22	Refrigerante R22	Refrigerante R22		4210401	
	Refrigerante R407C	Coolant R407C	Kühmittel R407C	Réfrigérant R407C	Refrigerante R407C	Refrigerante R407C	Refrigerante R407C		4210405	
HP	Manometro alta pressione	High pressure gauge	Hochdruckmanometer	Manomètre haute pression	Manómetro alta presión	Manómetro alta presión	Manómetro alta pressão		4150411	

TAB. 5 TABELLA RICAMBI

TABLE OF SPARE PARTS

ERSATZTEILTABELLE



PIOVAN

TABLEAU PIECES DE RECHANGE

TABLA REPUESTOS

TABELA DAS PEÇAS DE REPOSIÇÃO

CH380

	Descrizione	Description	Beschreibung	Description	Descripción	Descrição	400V/3/50Hz	380V/3/60Hz	460V/3/60Hz
LP	Manometro bassa pressione	Low pressure gauge	Niederdruckmanometer	Manomètre basse pression	Manómetro baja presión	Manómetro baixa pressão	4150410		
	Elettropompa (standard)	Electric pump (standard)	Elektropumpe (standard)	Electropompe (standard)	Electrobomba (standard)	Electrobomba (standard)	4181969	4181913	4181903
M1	Tenuta per elettropompa (standard)	Seal for electric pump (standard)	Abdichtung elektropumpe (standard)	Tenue pour électropompe (standard)	Estaqueidad para electrobomba (standard)	Vedante para electrobomba (standard)	4180480	4180480	4180489
	Elettropompa (maggiorata)	Electric pump (enhanced)	Elektropumpe (größere)	Electropompe (majorée)	Electrobomba (sobredimensionada)	Electrobomba (potência maior)	4181295	4181916	4181296
M2	Tenuta per elettropompa (maggiorata)	Seal for electric pump (enhanced)	Abdichtung elektropumpe (größere)	Tenue pour électropompe (majorée)	Estaqueidad para electrobomba (sobredimensionada)	Vedante para electrobomba (potência maior)		4180480	
	Elettroventilatore	Electric fan	Elektroventilator	Ventilateur électrique	Electroventilador	Electroventilador	4170477	4170476	4170474
M3	Compressore (R22)	Compressor (R22)	Verdichter (R22)	Compresseur (R22)	Compresor (R22)	Compressor (R22)	4181723	4181724	4181720
	Compressore (R407C)	Compressor (R407C)	Verdichter (R407C)	Compresseur (R407C)	Compresor (R407C)	Compressor (R407C)	4181577	4181746	4181740
SF1	Pressostato differenziale	Differential pressure switch	Differential druckmesser	Pressostat différentiel	Presóstato diferencial	Pressostato differenziale		4152026	
SP1	Pressostato ventilatore	Fan pressure switch	Druckwächter ventilator	Pressostat ventilateur	Presóstato ventilador	Pressostato ventilador		4152038	
SP2	Pressostato di alta pressione	high pressure switch	Druckwächter hoher druck	Pressostat de haute pression	Presóstato de alta presión	Pressostato de alta pressão		4152053	
SP3	Pressostato di bassa pressione	low pressure switch	Druckwächter niedriger druck	Pressostat de basse pression	Presóstato de baja presión	Pressostato de baixa pressão		4152040	
	Elettrovalvola	Solenoid valve	Magnetventil	Electrovanne	Electroválvula	Electroválvula		4551221	
YV1	Bobina	Coil	Spule	Bobine	Bobina	Bobina		4551057	
	Elettrovalvola	Solenoid valve	Magnetventil	Electrovanne	Electroválvula	Electroválvula		4551227	
YV2	Bobina	Coil	Spule	Bobine	Bobina	Bobina		4551057	



CH380

Descrizione	Description	Beschreibung	Description	Descripción	Descrição	400V/3/50Hz	380V/3/60Hz	460V/3/60Hz
Oilio compressore R22	Oil for compressor	Öl fuer Verdichter	Huile compresseur	Aceite compresor	Óleo compressor		4210228	
Oilio compressore R407C	Oil for compressor	Öl fuer Verdichter	Huile compresseur	Aceite compresor	Óleo compressor		4210226	
Filtro acqua completo di cartuccia	Water complete cartridge	Wasserfilter komplett mit Papierfilter	Filtre eau avec cartouche	Filtro de agua completo de cartucho	Filtro água completo com elemento		4240435	
Cartuccia filtro acqua	Cartridge for water filter	Wasserpapierfilter	Cartouche filtre eau	Cartucho filtro agua	Elemento filtro de água		4240603	

TAB. 6 TABELLA RICAMBI

TABLE OF SPARE PARTS

ERSATZTEILTABELLE

TABLEAU PIECES DE RECHANGE

TABLA REPUESTOS

TABELA DAS PEÇAS DE REPOSIÇÃO



CH480

	Descrizione	Description	Beschreibung	Description	Description	Descripción	Descrição	400V/3/50Hz	380V/3/60Hz	460V/3/60Hz
1	Valvola sfiato automatica	Automatic vent valve	Automatisches Entlüftungsventil	Soupape purge automatique	Válvula desfogue automática	Válvula drenagem automática	4190601			
3	Valvola di sicurezza	Safety valve	Sicherheitsventil	Soupape de sureté	Válvula de seguridad	Válvula de segurança	4190635			
4	Valvola di caricamento acqua	Filling valve	Füllungsventil	Vanne de remplissage	Valvula de relleno	Válvula de carregamento.	4190603			
11	Manometro pressione mandata	Delivery pressure gauge	Manometer vorlaufdruck	Manomètre pression refoulement	Manómetro presión de impulsión	Manómetro pressão alimentação	4150419			
13	Valvola di espansione termostatica	Thermostatic expansion valve	Thermostatisches Expansionsventil	Détendeur thermostatique	Válvula de expansión termostática	Válvula de expansão termostática	4190465			
15	Filtro aria	Air filter	Luftfilter	Filter air	Filtro aire	Filtro do ar	4240258			
17	Filtro deidratatore	Dehydrator filter	Dehydrierungsfilter	Filter de déshydratation	Filtro deshidratator	Filtro desidratator	4240457			
18	Indicatore refrigerante	Coolant indicator	Kühmittelanzeige	Indicateur réfrigérant	Indicator refrigerante	Indicator do refrigerante	4190528			
BT1	Sonda temperatura processo	Process temperature probe	Prozestemperatursonde	Détecteur température processus	Sonda temperatura proceso	Sonda temperatura processo	4151258			
BT2	Sonda temperatura antigelo	Antifreeze temperature probe	Antifrost temperaturesonde	Détecteur température antigel	Sonda temperatura anticongelante	Sonda temperatura anticongelante	4151258			
C	Condensatore	Condenser	Kondensator	Condenseur	Condensador	Condensador	610A1630			
E	Evaporatore	Evaporator	Verdampfer	Evaporateur	Evaporador	Evaporador	4280165			
EH1	Resistenza carter	Crankcase heater	Heizwiderstand gehäuse	Resistance carter	Resistencia cárter	Resistencia cárter	4180650			
G	Refrigerante R22	Coolant R22	Kühmittel R22	Réfrigérant R22	Refrigerante R22	Refrigerante R22	4210401			
	Refrigerante R407C	Coolant R407C	Kühmittel R407C	Réfrigérant R407C	Refrigerante R407C	Refrigerante R407C	4210405			
HP	Manometro alta pressione	High pressure gauge	Hochdruckmanometer	Manomètre haute pression	Manómetro alta presión	Manómetro alta pressão	4150411			



PIOVAN

ERSATZTEILTABELLE

TABLE OF SPARE PARTS

TAB. 6 TABELLA RICAMBI

TABELA DAS PEÇAS DE REPOSIÇÃO

TABLA REPUESTOS

TABEAU PIECES DE RECHANGE

CH480

	Descrizione	Description	Beschreibung	Description	Descripción	Descrição	400V/3/50Hz	380V/3/60Hz	460V/3/60Hz
LP	Manometro bassa pressione	Low pressure gauge	Niederdruckmanometer	Manomètre basse pression	Manómetro baja presión	Manómetro baixa pressão		4150410	
	Elettropompa (standard)	Electric pump (standard)	Elektropumpe (standard)	Electropompe (standard)	Electrobomba (standard)	Electrobomba (standard)	4181971	4181914	4181904
M1	Tenuta per elettropompa (standard)	Seal for electric pump (standard)	Abdichtung elektropumpe (standard)	Tenue pour électropompe (standard)	Estaqueidad para electrobomba (standard)	Vedante para electrobomba (standard)	4180480		4180489
	Elettropompa (maggiorata)	Electric pump (enhanced)	Elektropumpe (größere)	Electropompe (majorée)	Electrobomba (sobredimensionada)	Electrobomba (potência maior)	4181295	4181916	4181296
M2	Tenuta per elettropompa (maggiorata)	Seal for electric pump (enhanced)	Abdichtung elektropumpe (größere)	Tenue pour électropompe (majorée)	Estaqueidad para electrobomba (sobredimensionada)	Vedante para electrobomba (potência maior)		4180480	
	Elettroventilatore	Electric fan	Elektroventilator	Ventilateur électrique	Electroventilador	Electroventilador	4170477	4170476	4170474
M3	Compressore (R22)	Compressor (R22)	Verdichter (R22)	Compresseur (R22)	Compresor (R22)	Compressor (R22)	4181725	4181726	4181723
	Compressore (R407C)	Compressor (R407C)	Verdichter (R407C)	Compresseur (R407C)	Compresor (R407C)	Compressor (R407C)	4181727	4181755	4181577
SF1	Pressostato differenziale	Differential pressure switch	Differential druckmesser	Pressostat différentiel	Presóstato diferencial	Pressostato differenziale		4152026	
SP1	Pressostato ventilatore	Fan pressure switch	Druckwächter ventilator	Pressostat ventilateur	Presóstato ventilador	Pressostato ventilador		4152038	
SP2	Pressostato di alta pressione	high pressure switch	Druckwächter hoher druck	Pressostat de haute pression	Presóstato de alta presión	Pressostato de alta pressão		4152053	
SP3	Pressostato di bassa pressione	low pressure switch	Druckwächter niedriger druck	Pressostat de basse pression	Presóstato de baja presión	Pressostato de baixa pressão		4152040	
YV1	Elettrovalvola	Solenoid valve	Magnetventil	Electrovanne	Electroválvula	Electroválvula		4551221	
	Bobina	Coil	Spule	Bobine	Bobina	Bobina		4551057	
YV2	Elettrovalvola	Solenoid valve	Magnetventil	Electrovanne	Electroválvula	Electroválvula		4551227	
	Bobina	Coil	Spule	Bobine	Bobina	Bobina		4551057	

**PIOVAN**

TAB. 6 **TABELLA RICAMBI** **TABLE OF SPARE PARTS** **ERSATZTEILTABELLE**
TABLEAU PIECES DE RECHANGE **TABLA REPUESTOS** **TABELA DAS PEÇAS DE REPOSIÇÃO**

CH480

	Descrizione	Description	Beschreibung	Description	Descripción	Descrição	400V/3/50Hz	380V/3/60Hz	460V/3/60Hz
	Oilio compressore R22	Oil for compressor	Öl fuer Verdichter	Huile compresseur	Aceite compresor	Óleo compressor		4210228	
--	Oilio compressore R407C	Oil for compressor	Öl fuer Verdichter	Huile compresseur	Aceite compresor	Óleo compressor		4210226	
12	Filtro acqua completo di cartuccia	Water complete cartridge	Wasserfilter komplett mit Papierfilter	Filtre eau avec cartouche	Filtro de agua completo cartucho	Filtro água completo com elemento		4240435	
	Cartuccia filtro acqua	Cartridge for water filter	Wasserpapierfilter	Cartouche filtre eau	Cartucho filtro agua	Elemento filtro de água		4240603	

1	2	3	4	5	6	7	8	9	10
	M1 [kW] Pompa Pump Pumpe Pompe Bomba Bomba	Alimentazione Supply Spannung Alimentation Alimentacion Alimentacao	Ia (MAX) Corrente massima assorbita Maximum load current. Maximal aufgenommenen Strom Courant maximum absorbe Corriente mExima absorbida Corrente mExima absorvida	IS Corrente di spunto Peak current Anlaufstrom Courant initial de dEmarrage Corrente inicial de arranque Corrente de arranque	[A] Potenza installata Power installed Instal. Gesamtleistung Puissance installée Potencia instalada Potencia instalada	[kW] FUO Protezione consigliata Recommended protection Empfohlener Schutz Protection conseillée Protección recomendada Protecao aconselhada			
CH50 960H516	0.55	400V/3ph/50HZ + PE	7.4	25	4.1	16	4.1 4.6	16 (3x2.5 + 1x2.5mm ² MAX 15m)	
	0.75	460V/3ph/60HZ + PE	7.1	18	4.6				
CH50 [*] 960H516	1.85	400V/3ph/50HZ + PE	10.3	28	6.6	16	6.6 6.3	16 (3x2.5 + 1x2.5mm ² MAX 15m)	
	1.5	460V/3ph/60HZ + PE	8.3	20	6.3				
CH90 960H516	0.55	400V/3ph/50HZ + PE	9.3	42	4.9	16	4.9 5.7	16 (3x2.5 + 1x2.5mm ² MAX 15m)	
	0.75	460V/3ph/60HZ + PE	9	35	5.7				
CH90 [*] 960H516	1.85	400V/3ph/50HZ + PE	12.2	45	7.4	16	7.4 7.4	16 (3x2.5 + 1x2.5mm ² MAX 15m)	
	1.5	460V/3ph/60HZ + PE	10.2	36	7.4				

* POMPA MAGGIORATA
ENHANCED PUMP
GROEBERE PUMPE
POMPE MAJOREE
BOMBASOBREDIMENSIONADA
BOMBAPOTENCIAMAIOR

Variazioni		Nome	Data	Nome	Dis.	Data	Nome	Dis.	Data	Nome	Dis.	Data	Nome
a													
b													
c													
d													

 P I O V A N
UFFICIO TECNICO

Des. 960H516/517/518

Luogo

Impianto

Prog. CH50-90/180-280/380-480
Revisione REV.0 * 23.05.01 * A.S.

Nome

23.05.01

Dis.

Nome

A.S.

Ver.

Pg.

1

20

	1	2	3	4	5	6	7	8	9	10
	M1 [kW] Pompa Pump Pumpe Pompe Bomba Bomba	Alimentazione Supply Spannung Alimentation Alimentacion Alimentacao	Ia (MAX) Corrente massima assorbita Maximum load current. Maximal aufgenommen Strom Courant maximum absorbé Corriente mExima absorbida Corriente mExima absorvida	I S Corrente di spunto Peak current Anlaufstrom Courant initial de démarrage Corriente inicial de arranque Corriente de arranque	[kW] Potenza installata Power installed Instal. Gesamtleistung Puissance installée Potencia instalada Potencia instalada	FUO Protezione consigliata Recommended protection Empfohlener Schutz Protection conseillée Protección recomendada Protecao aconselhada				
CH180 960H517	0.9	400V/3ph/50HZ + PE	16.2	75	8.3	25				
	1.1	460V/3ph/60HZ + PE	14.5	66	8.8	(3x6 + 1x6 mm ² MAX 15m)				
CH180 [*] 960H517	1.85	400V/3ph/50HZ + PE	18.4	77	9.6	25				
	1.5	460V/3ph/60HZ + PE	15.2	67	10.5	(3x6 + 1x6 mm ² MAX 15m)				
CH280 960H517	1.1	400V/3ph/50HZ + PE	25.5	132	13.3	63				
	1.5	460V/3ph/60HZ + PE	22.9	121	14.4	(3x16 + 1x16 mm ² MAX 15m)				
	1.5	380V/3ph/60HZ + PE	27.4	150	14.4					
CH280 [*] 960H517	3	400V/3ph/50HZ + PE	29.2	136	15.6	63				
	3	460V/3ph/60HZ + PE	25.7	124	17.4	(3x16 + 1x16 mm ² MAX 15m)				
	3	380V/3ph/60HZ + PE	30.9	153	17.4					

* POMPA MAGGIORATA
ENHANCED PUMP
GROEBERE PUMPE
BOMBASOBREDIMENSIONADA
BOMBAPOTENCIAMAIOR

a	b	c	d	Variazioni		Nome		Data		Dis.	Ver.	Dis. N.	Luogo	Impianto
				Data	Nome	Data	Nome							
								23.05.01	A. S.			960H516/517/518		
												REV.0 * 23.05.01 * A. S.		Pg. 2
														20



P.I.O.VAN

UFFICIO TECNICO

CH50-90/180-280/380-480

	1	2	3	4	5	6	7	8	9	10	
	M1 [kW]	Alimentazione Supply Spannung Alimentation Alimentacion Alimentacao	Ia (MAX) Corrente massima assorbita Maximum load current. Maximal aufgenommener Strom Courant maximum absorbé Corriente máxima absorbida Corriente máxima absorvida	IS Corrente di spunto Peak current Anlaufstrom Courant initial de démarrage Corriente inicial de arranque Corriente de arranque	[kW] Potenza installata Power installed Instal. Gesamtleistung Puissance installée Potencia instalada Potencia instalada	FUO Protezione consigliata Recommended protection Empfohlener Schutz Protection conseillée Protección recomendada Protecao aconselhada					
	1.5	400V/3ph/50HZ + PE	32.4	165	16.4	63					
CH380 960H518	1.5	460V/3ph/60HZ + PE	28.2	135	17.5	(3x16 + 1x16 mm ² MAX 15m)					
	1.5	380V/3ph/60HZ + PE	33.4	159	17.1						
	3	400V/3ph/50HZ + PE	35.1	168	18.7	63					
CH380 960H518	3	460V/3ph/60HZ + PE	31	137	20.5	(3x16 + 1x16 mm ² MAX 15m)					
	3	380V/3ph/60HZ + PE	36.9	163	20.1						
	1.85	400V/3ph/50HZ + PE	38.2	197	20.2	63					
CH480 960H518	1.85	460V/3ph/60HZ + PE	33.3	166	20.6	(3x16 + 1x16 mm ² MAX 15m)					
	1.85	380V/3ph/60HZ + PE	39.5	204	20.1						
	3	400V/3ph/50HZ + PE	40	199	21.9	63					
CH480 960H518	3	460V/3ph/60HZ + PE	35.5	168	23.3	(3x16 + 1x16 mm ² MAX 15m)					
	3	380V/3ph/60HZ + PE	42.4	207	22.9						

* POMPA MAGGIORATA

ENHANCED PUMP
GROEBERE PUMPE
POMPE MAJOREE
BOMBASOBREDIMENSIONADA
BOMBAPOTENCIAMAIOR

a	b	c	d	VARIANTI		PIOVAN		UFFICIO TECNICO	
				Nome	Data	Nome	Data	Nome	Data
					23.05.01				

Dis. N.	960H516/517/518	Luogo	Impianto
Rev. N.	REV.0 * 23.05.01 * A.S.		
Prog.	CH50-90/180-280/380-480		
Pg.	3		
	20		

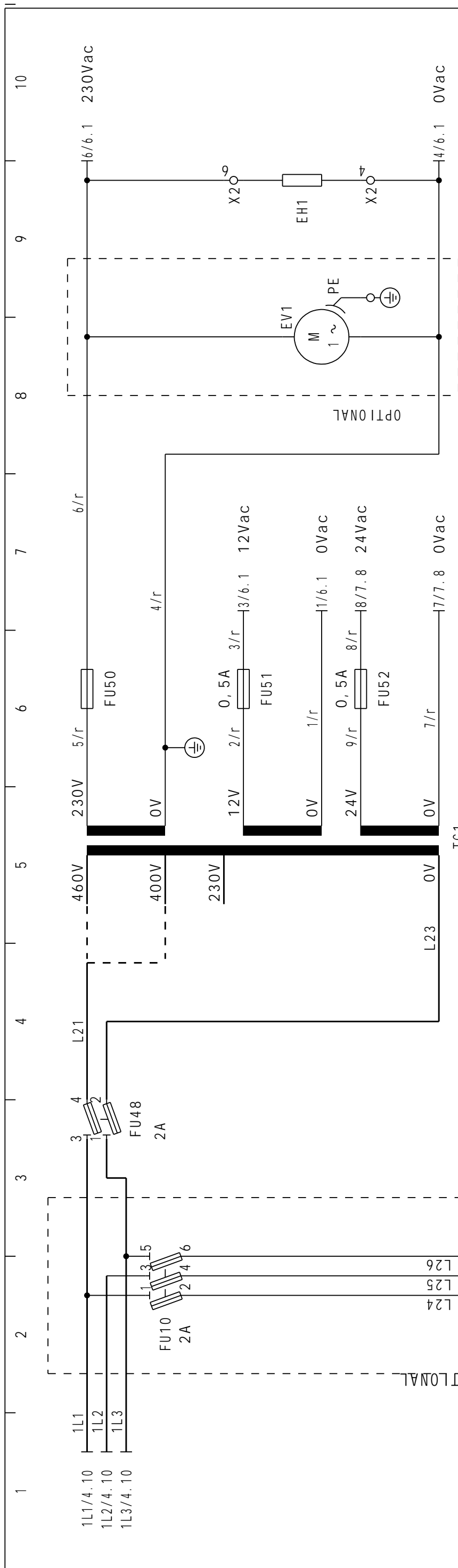

* (Pag. 4)

	ALIMEN. / SUPPLY	QM3
CH50	400V / 3 / 50HZ 460V / 3 / 60HZ 380V / 3 / 60HZ	4.5 A 3.5 A 4 A
CH90	400V / 3 / 50HZ 460V / 3 / 60HZ 380V / 3 / 60HZ	6.3 A 5.1 A 5.8 A
CH180	400V / 3 / 50HZ 460V / 3 / 60HZ 380V / 3 / 60HZ	12 A 10.5 A 12 A
CH280	400V / 3 / 50HZ 460V / 3 / 60HZ 380V / 3 / 60HZ	21 A 18.5 A 22 A
CH380	400V / 3 / 50HZ 460V / 3 / 60HZ 380V / 3 / 60HZ	25.5 A 22 A 25 A
CH480	400V / 3 / 50HZ 460V / 3 / 60HZ 380V / 3 / 60HZ	30 A 25.5 A 30.5 A

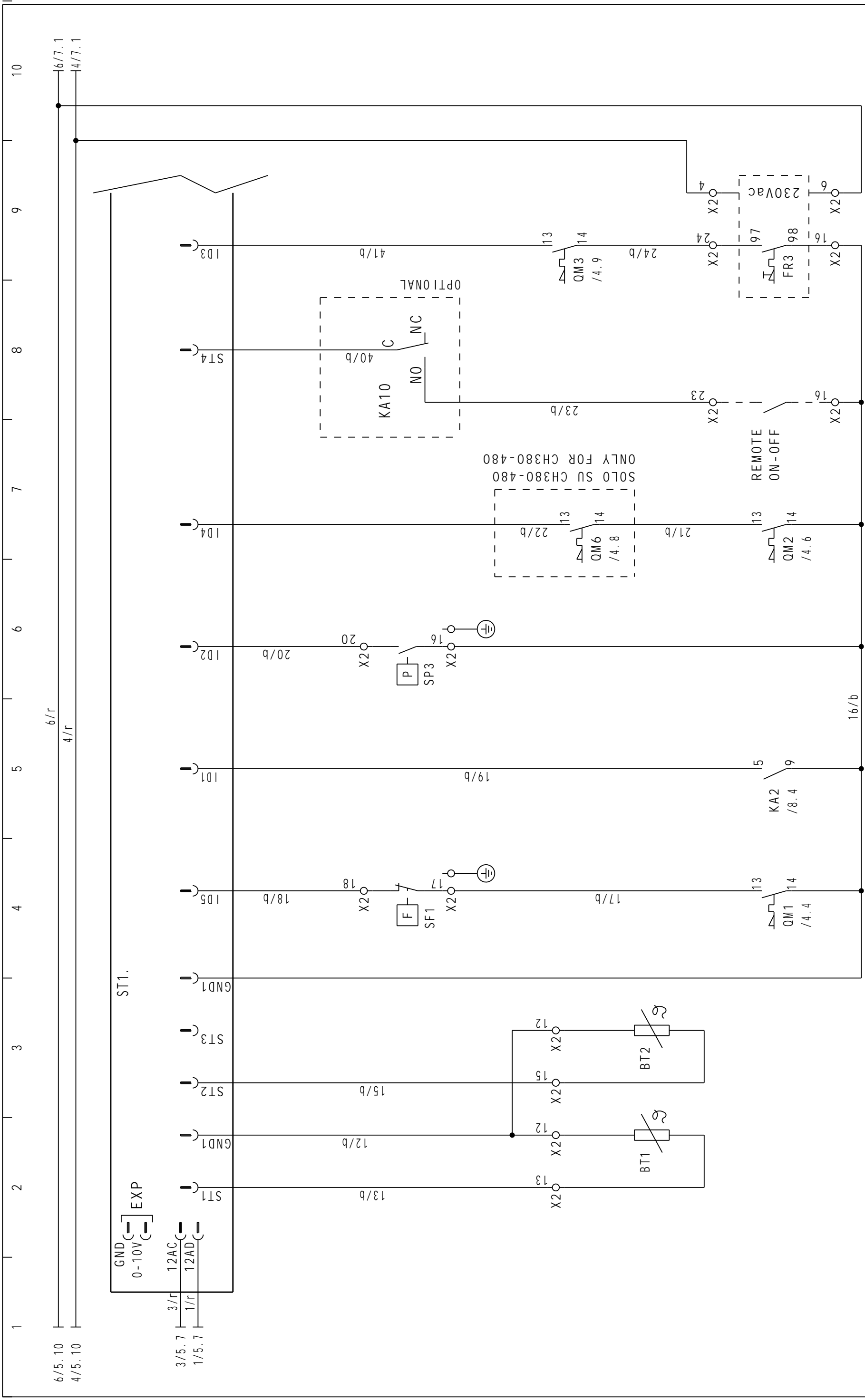

6/5.10	6/r	10
4/5.10	4/r	10
3/5.7	3/r	
1/5.7	1/r	

ST1	13/b	X20 13	
GND1	12/b	X20 12	
ST2	15/b	X20 15	
ST3			
GND1			
ID5	18/b	X20 18	
ID1	19/b	X20 19	
ID2	20/b	X20 20	
ID3	41/b	X20 41	
ID4	22/b	X20 22	
ID3	40/b	X20 40	
	23/b	X20 23	
	24/b	X20 24	
	4/b	X20 4	
	6/b	X20 6	

Dis. N.	960H516/517/518	Luogo	
Revisione	REV.0 * 23.05.01 * A.S.	Prog.	CH50-90/180-280/380-480
Des.	UFFICIO TECNICO		
Impianto		Pg.	6
			20

Variazioni	Data	Nome
a	23.05.01	A.S.
b		
c		
d		

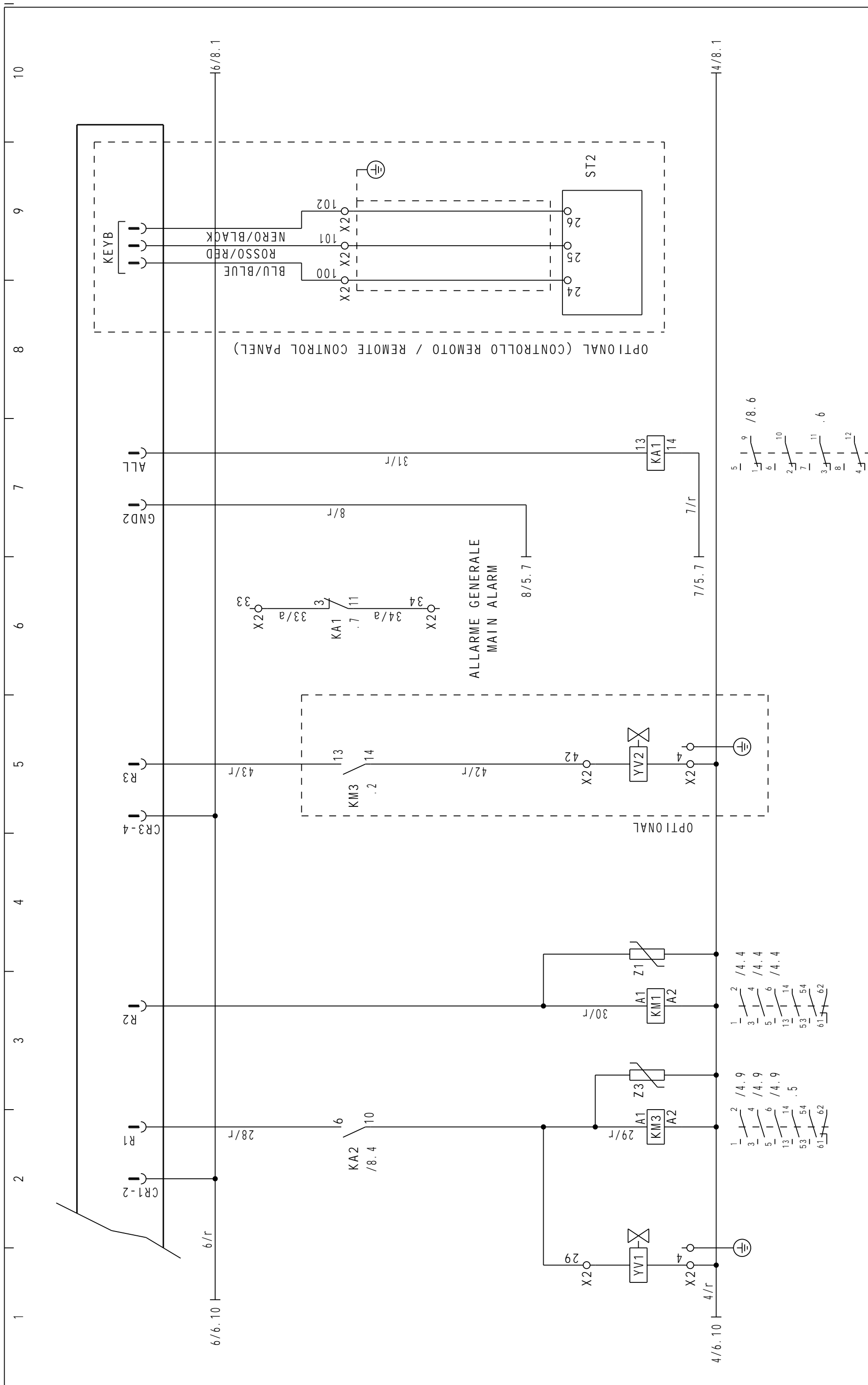

Variazioni	Data	Nome	Data	Nome	Dis.	Luogo	Impianto
a			23.05.01	A.S.		960H516/517/518	
b							
c							
d							

Des.	CH50-90/180-280/380-480
Prog.	REV.0 * 23.05.01 * A.S.
Dis. N.	960H516/517/518
Revisione	REV.0 * 23.05.01 * A.S.
Luogo	
Impianto	
Pg.	7
	20

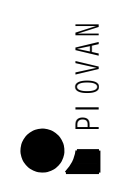

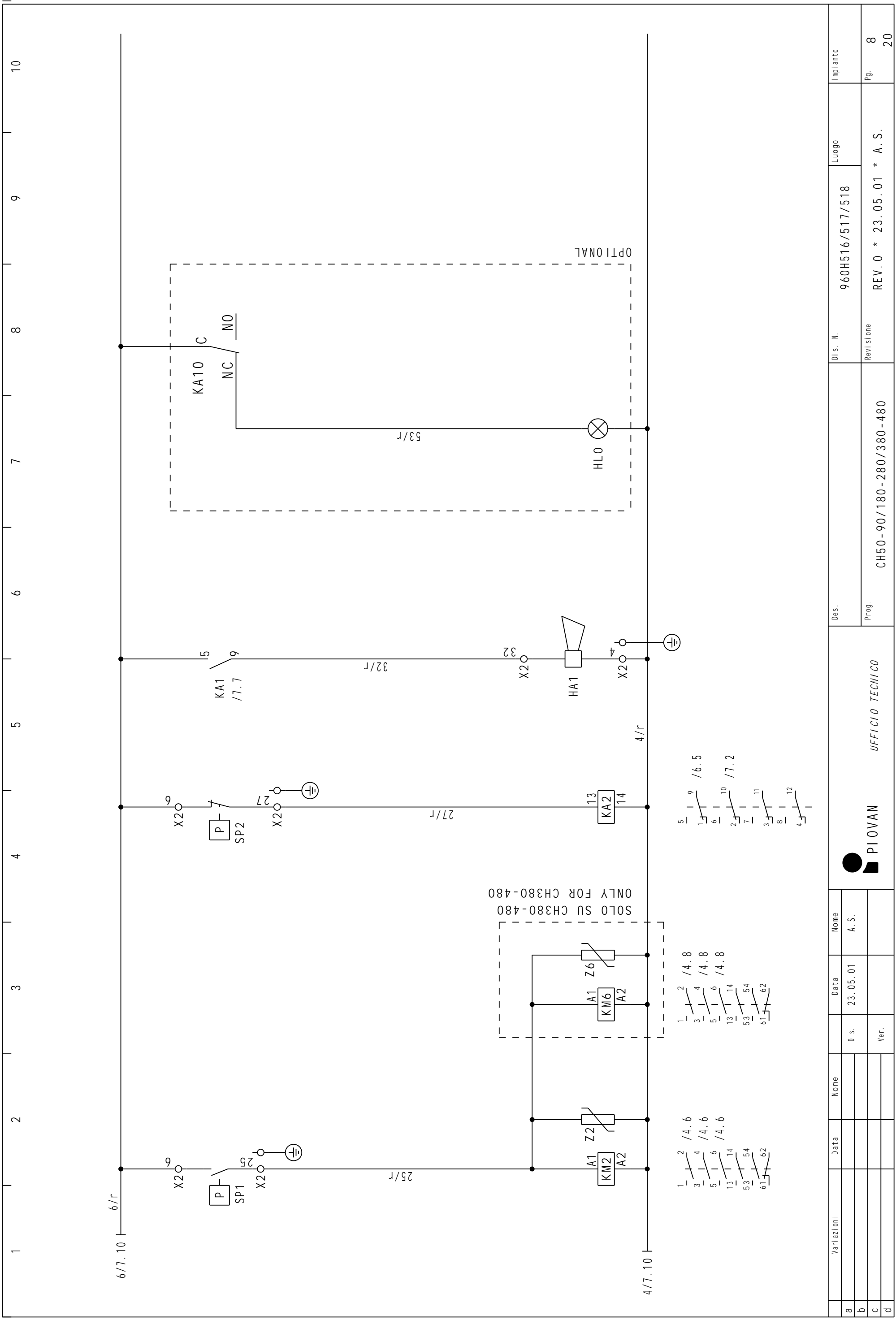

Variazioni	Data	Nome	Data	Nome
a				
b				
c				
d				

Dis. N.	Luogo	Impianto
960H516/517/518		

Des.	Prog.
CH50-90/180-280/380-480	

UFFICIO TECNICO	PIOVAN

Dis.	Ver.	Data	Nome
23.05.01			A. S.

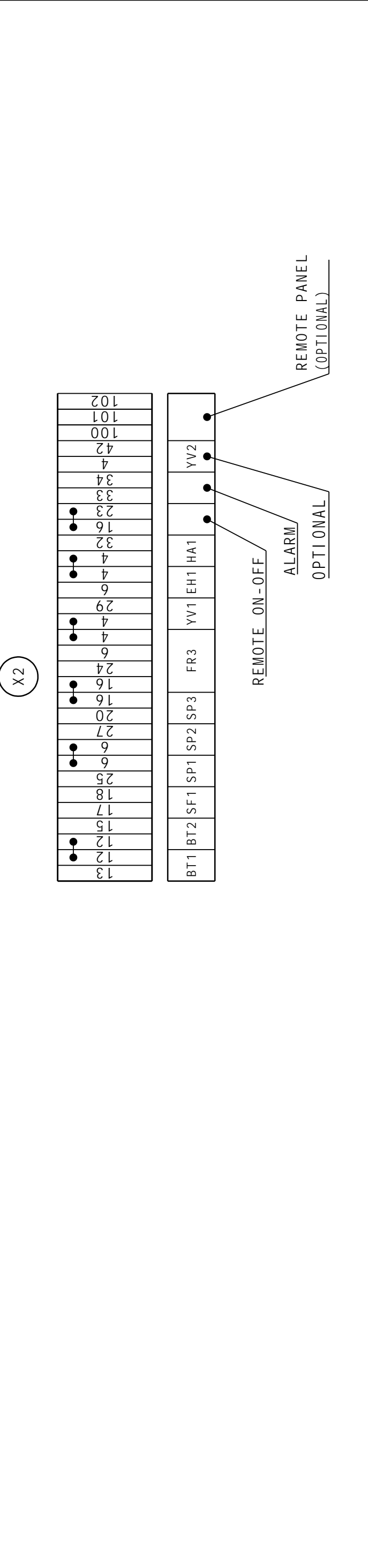
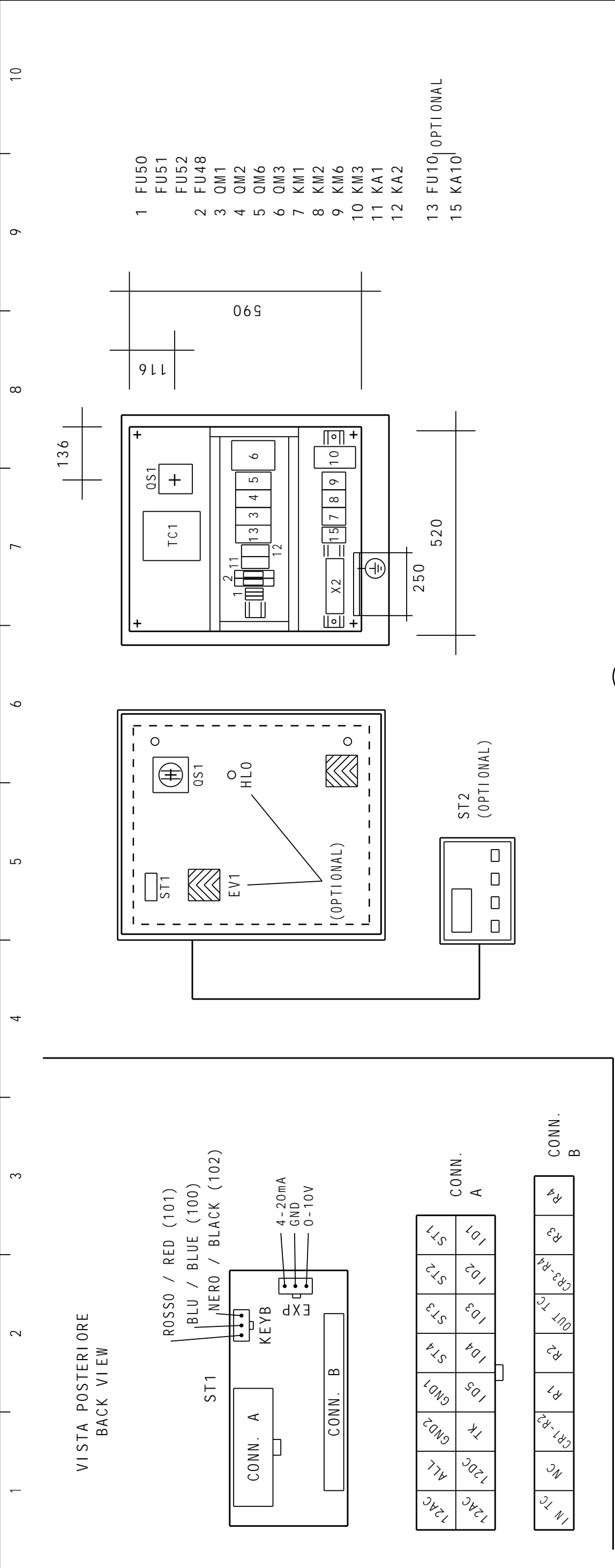

a	Variazioni	Data	Nome	Data	Nome	Dis. N.	Luogo	Impianto
b				23.05.01	A. S.		960H516/517/518	
c						Prog.	CH50-90/180-280/380-480	Revisione
d							REV.0 * 23.05.01 * A. S.	Pg.
								20

960H516			
TAB. 01	400/50*380-460/60	400/50*380/60	460/60
		400/50*380-460/60	400/50*380/60
		CH90	
	NORMAL PUMP	SPECIAL PUMP	SPECIAL PUMP
FU0	max. 25A aM		
FU50	4520207 5X20 1A STANDARD		
KM1	4512301 3RT1015-1AP01 SIEMENS		
KM2	4512301 3RT1015-1AP01 SIEMENS		
KM3	4512302 3RT1016-1AP01 SIEMENS		
KM6	/		
QM1	4514546 3RV1011-1BA10 1, 4-2A SIEMENS	4514550 3RV1011-1FA10 3, 5-5A SIEMENS	4514548 3RV1011-1DA10 2, 2-3, 2A SIEMENS
QM2	(400/3/50) (380-460/3/60) 4514545-3RV1011-1AA10 4514546-3RV1011-1BA10 1, 1-1.6 SIEMENS 1, 4-2 SIEMENS		
QM3	4514550 3RV1011-1FA10 3. 5-5 SIEMENS		
QM6	/		
QS1	4514825 : P1-25/V/SVB 25A MOELLER		
TC1	4511406 160VA PR=0-230-400-460V S1=0-230V (148VA) S2=0-12V (6VA) S3=0-24V (6VA)		



TAB. 02		960H517	
400/50*380-460/60	400/50*380/60	460/60	400/50*380-460/60
CH180		CH280	
NORMAL PUMP	SPECIAL PUMP	NORMAL PUMP	SPECIAL PUMP
FU0		max. 63A aM	
FU50		4520250 5x20 1,6A STANDARD	
KM1	3RT1015-1AP01 SIEMENS	4512301 3RT1015-1AP01 SIEMENS	4512301 3RT1015-1AP01 SIEMENS
KM2	3RT1015-1AP01 SIEMENS	4512301 3RT1015-1AP01 SIEMENS	4512301 3RT1015-1AP01 SIEMENS
KM3	3RT1034-1AL20 SIEMENS	4512306 3RT1034-1AL20 SIEMENS	4512306 3RT1034-1AL20 SIEMENS
KM6	/	/	/
QM1	4514548 3RV1011-1DA10 2,2-3,2A SIEMENS	4514550 3RV1011-1FA10 3,5-5A SIEMENS	4514548 3RV1011-1DA10 2,2-3,2A SIEMENS
QM2	3RV1011-1BA10 1,4-2A SIEMENS	4514546 3RV1011-1BA10 1,4-2A SIEMENS	4514546 3RV1011-1BA10 1,4-2A SIEMENS
QM3	3RV1011-1KA10 9-12 SIEMENS	4514554 3RV1011-4CA10 17-22 SIEMENS	4514571 3RV1021-4CA10 17-22 SIEMENS
QM6	/	/	/
OS1	4514827 : P3-63/V/SVB 63A MOELLER	4514827 : P3-63/V/SVB 63A MOELLER	4514827 : P3-63/V/SVB 63A MOELLER
TC1	4511407 250VA PR=0-230-400-460V S1=0-230V (238VA) S2=0-12V (6VA) S3=0-24V (6VA)	4511407 250VA PR=0-230-400-460V S1=0-230V (238VA) S2=0-12V (6VA) S3=0-24V (6VA)	4511407 250VA PR=0-230-400-460V S1=0-230V (238VA) S2=0-12V (6VA) S3=0-24V (6VA)

TAB. 03		960518	
400/50*380-460/60	400/50*380-460/60	400/50*380-460/60	400/50*380-460/60
CH380		CH480	
NORMAL PUMP	SPECIAL PUMP	NORMAL PUMP	SPECIAL PUMP
FU0 max. 63A aM			
FU50 4520210 5x20 2A STANDARD			
KM1 4512303 3RT1017-1AP01 SIEMENS			
KM2 4512301 3RT1015-1AP01 SIEMENS			
KM3 4512308 3RT1036-1AL20 SIEMENS			
KM6 4512301 3RT1015-1AP01 SIEMENS			
QM1 4514549 3RV1011-1EA10 2,8-4A SIEMENS		4514552 3RV1011-1HA10 5,5-8A SIEMENS	
QM2 4514546 3RV1011-1BA10 1,4-2A SIEMENS		4514546 3RV1011-1BA10 1,4-2A SIEMENS	
QM3 4514558 3RV1031-4EA10 22-32 SIEMENS		4514558 3RV1031-4EA10 22-32 SIEMENS	
QM6 4514546 3RV1011-1BA10 1,4-2A SIEMENS		4514546 3RV1011-1BA10 1,4-2A SIEMENS	
OS1 4514827 : P3-63/V/SVB 63A MOELLER			
TC1 4511408 400VA PR=0-230-400-460V S1=0-230V (388VA) S2=0-12V (6VA) S3=0-24V (6VA)		4511408 400VA PR=0-230-400-460V S1=0-230V (388VA) S2=0-12V (6VA) S3=0-24V (6VA)	



960H516 CABLE	CH50			CH90		
	400V/50HZ	380V/60HZ	460V/60HZ	400V/50HZ	380V/60HZ	460V/60HZ
M1	4G1,5	4G1,5	4G1,5	4G1,5	4G1,5	4G1,5
M2	4G1	4G1	4G1	4G1	4G1	4G1
M3	4G1,5	4G1,5	4G1,5	4G1,5	4G1,5	4G1,5
M6	/	/	/	/	/	/

960H517 CABLE	CH180			CH280		
	400V/50HZ	380V/60HZ	460V/60HZ	400V/50HZ	380V/60HZ	460V/60HZ
M1	4G1,5	4G1,5	4G1,5	4G1,5	4G1,5	4G1,5
M2	4G1	4G1	4G1	4G1	4G1	4G1
M3	4G6	4G6	4G6	4G6	4G6	4G6
M6	/	/	/	/	/	/

960H518 CABLE	CH380			CH480		
	400V/50HZ	380V/60HZ	460V/60HZ	400V/50HZ	380V/60HZ	460V/60HZ
M1	4G1,5	4G1,5	4G1,5	4G1,5	4G1,5	4G1,5
M2	4G1	4G1	4G1	4G1	4G1	4G1
M3	4G10	4G10	4G10	4G10	4G10	4G10
M6	4G1	4G1	4G1	4G1	4G1	4G1

1	2	3	4	5	6	7	8	9	10
SIGLA	DESCRIZIONE			CODICE	Q. TA'	MODELLO	COSTRUTTORE	RIF.	
POS.	DESCRIPTION			CODE	Q. TY'	TYPE	MANUFACTURER	REF.	
SIGEL	BESCHREIBUNG			CODE	ANZ.	TYPE	HERSTELLER	BEZUG	
POS./PIECE	DESCRIPTION			CODE/PIECE	Q. TY'	TYPE	MANUFACTURER	REF.	
	MODELE/COMPOSANT			DE RECHANGE					
SIGLA	DESCRIPCION			CODIGO	CANTIDAD	MODELO	CONSTRUCTOR	REF.	
SIGLA	DESCRICA0			CODIGO	Q. DE	TIPO	FABRI CANTE	REF.	
BT1	SONDA TEMPERATURA INGRESSO (PROCESSO)			(*1)	1			6.2	
	INPUT TEMPERATURE PROBE (PROCESS)								
	RUCKLAUFSEITIGE TEMPERATURSONDE (PROZESS)								
	SONDE TEMPERATURE ENTREE (PROCESSUS)								
	SONDA TEMPERATURA ENTRADA (PROCESSO)								
	SONDA DA TEMPERATURA ENTRADA (PROCESSO)								
	SONDA TEMPERATURA USCITA (ANTIGELO)			(*1)	1			6.3	
	OUTPUT TEMPERATURE PROBE (ANTIFREEZE)								
	VORLAUFSEITIGE TEMPERATURSONDE (FROSTSCHUTZ)								
	SONDE TEMPERATURE SORTIE (ANTIGEL)								
	SONDA TEMPERATURA SALIDA (ANTICONGELANTE)								
	SONDA DA TEMPERATURA SAIDA (ANTIGELO)								
EV1	VENTILATORE QUADRO ELETRICO			417	1	4656-7-853	PAPST	5.8	
	VENTILATOR FOR ELECTRICAL BOX								
	VENTILATOR-SCHALTSCHRANK								
	VENTILATEUR TABLEAU ELECTRIQUE								
	VENTILADOR PARA TABLERO ELETRICO								
	VENTILADOR PARA O QUADRO ELETRICO								
EH1	RESISTENZA CARTER			(*1)	1			5.9	
	RESISTOR CASING								
	HEIZWIDERSTAND KURBELGEHAUSE								
	RESISTANCE CARTER								
	RESISTENCIA CARTER								
	RESISTENCIA CARTER								
FR3	PROTEZIONE TERMICA MOTORE M3			(*1)	1			6.9	
	MOTOR M3 THERMAL PROTECTION								
	M3 THERMOSCHUTZ								
	PROTECTION THERMIQUE DU MOTEUR M3								
	TERMICO PROTECCION MOTOR M3								
	PROTECAO TERMICA DO COMPRESSOR M3								
FUO	FUSIBILE LINEA A CURA CLIENTE			(*2)	3			4.2	
	LINE FUSES PROVIDED BY CUSTOMER								
	KUNDENSEITIGE LEITUNGSSICHERUNGEN								
	FUSIBLES PROTECTION LIGNE FOURNIS PAR LE CLIENT								
	FUSIBLE DE LINEA DEL CLIENTE								
	FUSIVEL DA LINHA POR CONTA DO CLIENTE								

Dis. N.	960H516/517/518	Luogo	Impianto
Prog.	CH50-90/180-280/380-480	Rev. 0 * 23.05.01 * A. S.	Pg. 14
Des.	UFFICIO TECNICO		
Prog.	PIOVAN		

1	2	3	4	5	6	7	8	9	10
SIGLA	DESCRIZIONE			CODICE	Q. TA'	MODELLO	COSTRUTTORE	RIF.	
POS.	DESCRIPTION			CODE	Q. TY'	TYPE	MANUFACTURER	REF.	
SIGEL	BESCHREIBUNG			CODE	ANZ.	TYPE	HERSTELLER	BEZUG	
POS./PIECE	DESCRIPTION			CODE/PIECE	Q. TY'	TYPE	MANUFACTURER	REF.	
	MODELE/COMPOSANT			DE RECHANGE					
SIGLA	DESCRIPCION			CODIGO	CANTIDAD	MODELO	CONSTRUCTOR	REF.	
SIGLA	DESCRICAIO			CODIGO	Q. DE	TIPO	FABRI CANTE	REF.	

FU10	FUSIBILE PROTEZIONE KA10 (OPTIONAL) KA10 PROTECTION FUSE (OPTIONAL) SICHERUNG KA10 (OPTIONAL) FUSIBLE PROTECTION KA10 (OPTION) FUSIBLE PROTECCION KA10 (OPCIONAL) FUSIVEL DA PROTECAO KA10 (OPCIONAL) FUSIBILE PROTEZIONE TC1 TC1 PROTECTION FUSE SICHERUNG TC1 FUSIBLE PROTECTION TC1 FUSIBLE PROTECCION TC1 FUSIVEL DA PROTECAO TC1 FUSIBILE PROTEZIONE AUSILIARI 230VAC AUXILIARY 230VAC PROTECTION FUSE ZUSATZSICHERUNG 230VAC FUSIBLE DE PROTECTION DES AUXILIAIRE 230VAC FUSIBLE PROTECCION AUXILIARES 230VAC FUSIVEL DE PROTECAO AUXILIAR 230VAC FUSIBILE PROTEZIONE AUSILIARI 12VAC AUXILIARY 12VAC PROTECTION FUSE ZUSATZSICHERUNG 12VAC FUSIBLE DE PROTECTION DES AUXILIAIRE 12VAC FUSIBLE PROTECCION AUXILIARES 12VAC FUSIVEL DE PROTECAO AUXILIAR 12VAC FUSIBILE PROTEZIONE AUSILIARI 24VAC AUXILIARY 24VAC PROTECTION FUSE ZUSATZSICHERUNG 24VAC FUSIBLE DE PROTECTION DES AUXILIAIRE 24VAC FUSIBLE PROTECCION AUXILIARES 24VAC FUSIVEL DE PROTECAO AUXILIAR 24VAC SIRENA D'ALLARME (OPTIONAL) ALARM HORN (OPTIONAL) ALARM SIRENE (OPTIONAL) SIRENE D'ALARME (OPTION) SIRENA DE ALARME (OPCIONAL) SIRENE DE ALARME (OPCIONAL)			4521807	3	10x38 2A GG 3NW6002-1	SIEMENS	5.2	
FU48				4521807	2	10x38 2A GG 3NW6002-1	SIEMENS	5.4	
FU50				(*2)	1			5.7	
FU51				4520249	1	5x20 0, 5A	STANDARD	5.7	
FU52				4520249	1	5x20 0, 5A	STANDARD	5.7	
HA1				4570627	1	SIRLAT B 230VAC	SIRENA	8.7	

Variazioni		Data	Nome	Des.		Dis. N.		Luogo		Impianto	
a								960H516/517/518		A	
b				23.05.01		A. S.				Pg. 15	
c								REV. 0 * 23.05.01 * A. S.		20	
d								CH50-90/180-280/380-480		Prog.	



P.I.O.VAN

UFFICIO TECNICO

1	2	3	4	5	6	7	8	9	10
SIGLA	DESCRIZIONE			CODICE	Q. TA'	MODELLO	CONSTRUTTORE		RIF.
POS.	DESCRIPTION			CODE	Q. TY'	TYPE	MANUFACTURER		REF.
SIGEL	BESCHREIBUNG			CODE	ANZ.	TYPE	HERSTELLER		BEZUG
POS./PIECE	DESCRIPTION			CODE/PIECE	Q. TY'	TYPE	MANUFACTURER		REF.
	MODELE/COMPOSANT			DE RECHANGE					
SIGLA	DESCRIPCION			CODIGO	CANTIDAD	MODELO	CONSTRUCTOR		REF.
SIGLA	DESCRICA0			CODIGO	Q. DE	TIPO	FABRI CANTE		REF.

HLO	SPIA SEGNALAZIONE INTERVENTO KA10 (OPTIONAL) KA10 INTERVENTION SIGNALLING LAMP (OPTIONAL) SIGNALLAMPE ANSPRECHEN KA10 (OPTIONAL) VOYANT INTERVENTION KA10 (OPTION) LUZ INDICADORA INTERVENCION KA10 (OPCIONAL) INDICADOR LUMINOSO SINALIZACAO INTERV. KA10 (OPC.)			4570223	1	BA9S 230V	ARTELETA		8.7
KA1	RELE' AUSILIARIO ALLARME AUXILIARY RELAY FOR ALARM HILFSRELAIS ALARM RELAIS AUXILIAIRE DE ALARME RELE AUXILIAR DE ALARMA RELE AUXILIAR DE ALARME RELE' AUSILIARIO SP2 AUXILIARY RELAY SP2 HILFSRELAIS SP2 RELAIS AUXILIAIRE SP2 RELE AUXILIAR SP2 RELE AUXILIAR SP2			4513443	1	PT570.524 24VAC	SCHRACK		7.9
KA2	RELE' CONTROLLO FASE (OPTIONAL) RELAY-PHASE CONTROL (OPTIONAL) RELAIS PHASENFOLGE (OPTIONAL) RELAIS DE CONTROLE PHASE (OPTION) RELE CONTROL DE PHASE (OPCIONAL) RELE DO CONTROLLO FASE (OPCIONAL) CONTATTORE MOTORE M1 CONTACTOR MOTOR M1 KONTAKSCHALTER MOTOR M1 CONTACTEUR MOTEUR M1 CONTACTOR MOTOR M1 CONTATOR DO COMANDO M1 CONTATTORE MOTORE M2 CONTACTEUR MOTEUR M2 CONTACTOR MOTOR M2 KONTAKSCHALTER MOTOR M2 CONTACTEUR MOTEUR M2 CONTACTOR MOTOR M2 CONTATOR DO COMANDO M2			4513445	1	PT570.730 230VAC	SCHRACK		8.4
KA10	RELE' CONTROLLO FASE (OPTIONAL) RELAY-PHASE CONTROL (OPTIONAL) RELAIS PHASENFOLGE (OPTIONAL) RELAIS DE CONTROLE PHASE (OPTION) RELE CONTROL DE PHASE (OPCIONAL) RELE DO CONTROLLO FASE (OPCIONAL) CONTATTORE MOTORE M1 CONTACTOR MOTOR M1 KONTAKSCHALTER MOTOR M1 CONTACTEUR MOTEUR M1 CONTACTOR MOTOR M1 CONTATOR DO COMANDO M1 CONTATTORE MOTORE M2 CONTACTEUR MOTEUR M2 CONTACTOR MOTOR M2 KONTAKSCHALTER MOTOR M2 CONTACTEUR MOTEUR M2 CONTACTOR MOTOR M2 CONTATOR DO COMANDO M2			4513462 4513463	1 1	3UG3013-1BP60(380-400V) 3UG3013-1BR60(440-480V)	SIEMENS SIEMENS		5.2
KM1	CONTATTORE MOTORE M1 CONTACTOR MOTOR M1 KONTAKSCHALTER MOTOR M1 CONTACTEUR MOTEUR M1 CONTACTOR MOTOR M1 CONTATOR DO COMANDO M1 CONTATTORE MOTORE M2 CONTACTEUR MOTEUR M2 CONTACTOR MOTOR M2 KONTAKSCHALTER MOTOR M2 CONTACTEUR MOTEUR M2 CONTACTOR MOTOR M2 CONTATOR DO COMANDO M2			(*2)	1				4.2
KM2	CONTATTORE MOTORE M1 CONTACTOR MOTOR M1 KONTAKSCHALTER MOTOR M1 CONTACTEUR MOTEUR M1 CONTACTOR MOTOR M1 CONTATOR DO COMANDO M1 CONTATTORE MOTORE M2 CONTACTEUR MOTEUR M2 CONTACTOR MOTOR M2 KONTAKSCHALTER MOTOR M2 CONTACTEUR MOTEUR M2 CONTACTOR MOTOR M2 CONTATOR DO COMANDO M2			(*2)	1				4.3

Variazioni		Data	Nome	Des.		Dis. N.		Luogo		Impianto	
a								960H516/517/518		A	
b		23.05.01	A. S.							Pg. 16	
c								REV.0 * 23.05.01 * A. S.		20	
d								CH50-90/180-280/380-480			



PIOVAN

UFFICIO TECNICO

1	2	3	4	5	6	7	8	9	10
SIGLA	DESCRIZIONE			CODICE	Q. TA'	MODELLO	CONSTRUTTORE	RIF.	
POS.	DESCRIPTION			CODE	Q. TY'	TYPE	MANUFACTURER	REF.	
SIGEL	BESCHREIBUNG			CODE	ANZ.	TYPE	HERSTELLER	BEZUG	
POS./PIECE	DESCRIPTION			CODE/PIECE	Q. TY'	TYPE	MANUFACTURER	REF.	
	MODELE/COMPOSANT			DE RECHANGE					
SIGLA	DESCRIPCION			CODIGO	CANTIDAD	MODELO	CONSTRUCTOR	REF.	
SIGLA	DESCRICA0			CODIGO	Q. DE	TIPO	FABRI CANTE	REF.	

KM3	CONTATTORE MOTORE M3			(*2)	1			4.7	
	CONTACTOR MOTOR M3								
	KONTAKSCHALTER MOTOR M3								
	CONTACTEUR MOTEUR M3								
	CONTACTOR MOTOR M3								
	CONTATOR DO COMANDO M3								
KM6	CONTATTORE MOTORE M6			(*2)	1			4.5	
	CONTACTOR MOTOR M6								
	KONTAKSCHALTER MOTOR M6								
	CONTACTEUR MOTEUR M6								
	CONTACTOR MOTOR M6								
	CONTATOR DO COMANDO M6								
M1	MOTORE POMPA			(*1)	1			4.2	
	PUMP MOTOR								
	PUMPENMOTOR								
	MOTEUR POMPE								
	MOTOR BOMBA								
	MOTOR DA BOMBA								
M2	MOTORE VENTILATORE 1			(*1)	1			4.3	
	FAN MOTOR 1								
	VENTILATORMOTOR 1								
	MOTEUR VENTILATEUR 1								
	MOTOR VENTILADOR 1								
	MOTOR DO VENTILADOR 1								
M3	MOTORE COMPRESSORE			(*1)	1			4.7	
	COMPRESSOR MOTOR								
	KOMPRESSORMOTOR								
	MOTEUR COMPRESSEUR								
	MOTOR COMPRESOR								
	MOTOR DO COMPRESSOR								
M6	MOTORE VENTILATORE 2			(*1)	1			4.5	
	FAN MOTOR 2								
	VENTILATORMOTOR 2								
	MOTEUR VENTILATEUR 2								
	MOTOR VENTILADOR 2								
	MOTOR DO VENTILADOR 2								

Variazioni	Data	Nome	Data	Nome	Des.	Dis. N.	Luogo	Impianto
a			23.05.01	A. S.			960H516/517/518	A
b								
c							REV.0 * 23.05.01 * A. S.	Pg. 17
d								20



UFFICIO TECNICO

CH50-90/180-280/380-480

REV.0 * 23.05.01 * A. S.

Dis. N.

Luogo

960H516/517/518

Revisione

CH50-90/180-280/380-480

Des.

UFFICIO TECNICO



Nome

Data

Dis.

Nome

Data

Ver.

Nome

A. S.

1	2	3	4	5	6	7	8	9	10
SIGLA	DESCRIZIONE			CODICE	Q. TA'	MODELLO	CONSTRUTTORE	RIF.	
POS.	DESCRIPTION			CODE	Q. TY'	TYPE	MANUFACTURER	REF.	
SIGEL	BESCHREIBUNG			CODE	ANZ.	TYPE	HERSTELLER	BEZUG	
POS./PIECE	DESCRIPTION			CODE/PIECE	Q. TY'	TYPE	MANUFACTURER	REF.	
	MODELE/COMPOSANT			DE RECHANGE					
SIGLA	DESCRIPCION			CODIGO	CANTIDAD	MODELO	CONSTRUCTOR	REF.	
SIGLA	DESCRICA O			CODIGO	Q. DE	TIPO	FABRI CANTE	REF.	

QM1	MAGNETOTERMICO PROT. MOTORE M1			(*2)	1			4.2	
	M1 MOTOR SAFETY CUTOUT								
	THERMOSCHUETZ MOTOR M1								
	MAGNETOTHERMIQUE DE PROTECTION DU MOTEUR M1								
	MAGNETOTERMICO PROTECCION MOTOR M1								
	MAGNETOTERMICO DE PROTECAO DO MOTOR M1								
	MAGNETOTERMICO PROT. MOTORE M2								
	M2 MOTOR SAFETY CUTOUT								
	THERMOSCHUETZ MOTOR M2								
	MAGNETOTHERMIQUE DE PROTECTION DU MOTEUR M2								
	MAGNETOTERMICO PROTECCION MOTOR M2								
	MAGNETOTERMICO DE PROTECAO DO MOTOR M2								
	MAGNETOTERMICO PROT. MOTORE M3								
	M3 MOTOR SAFETY CUTOUT								
	THERMOSCHUETZ MOTOR M3								
	MAGNETOTHERMIQUE DE PROTECTION DU MOTEUR M3								
	MAGNETOTERMICO PROTECCION MOTOR M3								
	MAGNETOTERMICO DE PROTECAO DO MOTOR M3								
	MAGNETOTERMICO PROT. MOTORE M6								
	M6 MOTOR SAFETY CUTOUT								
	THERMOSCHUETZ MOTOR M6								
	MAGNETOTHERMIQUE DE PROTECTION DU MOTEUR M6								
	MAGNETOTERMICO PROTECCION MOTOR M6								
	MAGNETOTERMICO DE PROTECAO DO MOTOR M6								
QS1	INTERRUPTORE GENERALE			(*2)	1			4.2	
	MAIN SWITCH								
	HAUPTSCHALTER								
	INTERRUPTEUR GENERAL								
	INTERRUPTOR GENERAL								
	INTERRUPTOR GERAL								
	FLUSSOSTATO								
	FLOW SWITCH								
	DURCHFLUSSREGLER								
	REGULATEUR DE FLUX								
	INDICADOR DE FLUJO								
	FLUXIMETRO								
SF1				(*1)	1			6.4	

Variazioni	Data	Nome	Nome	Des.	Dis. N.	Luogo	Impianto
a			A. S.			960H516/517/518	A
b							
c				Prog.	Revisione	REV.0 * 23.05.01 * A. S.	Pg. 18
d						CH50-90/180-280/380-480	20



PIOVAN

UFFICIO TECNICO

1	2	3	4	5	6	7	8	9	10
SIGLA	DESCRIZIONE			CODICE	Q. TA'	MODELLO	COSTRUTTORE	RIF.	
POS.	DESCRIPTION			CODE	Q. TY'	TYPE	MANUFACTURER	REF.	
SIGEL	BESCHREIBUNG			CODE	ANZ.	TYPE	HERSTELLER	BEZUG	
POS./PIECE	DESCRIPTION			CODE/PIECE	Q. TY'	TYPE	MANUFACTURER	REF.	
	MODELE/COMPOSANT			DE RECHANGE					
SIGLA	DESCRIPCION			CODIGO	CANTIDAD	MODELO	CONSTRUCTOR	REF.	
SIGLA	DESCRICA0			CODIGO	Q. DE	TIPO	FABRI CANTE	REF.	
SP1	PRESSOSTATO VENTILATORE FAN MOTOR PRESSURE SWITCH DRUCKWACHTER VENTILATOR PRESSOSTAT VENTILATEUR PRESOSTATO VENTILADOR PRESSOSTATO DO VENTILADOR PRESSOSTATO MASSIMA PRESSIONE HIGH-PRESSURE SWITCH HOCHDRUCK DRUCKWACHTER PRESSOSTAT DE MAXIMUM PRESSION PRESOSTATO ALTA PRESSION PRESSOSTATO DE ALTA PRESSAO PRESSOSTATO MINIMA PRESSIONE LOW-PRESSURE SWITCH NIEDERDRUCK DRUCKWACHTER PRESSOSTAT DE MINIMUM PRESSION PRESOSTATO MINIMA PRESSOSTATO DE PRESSAO MINIMA			(*1)	1			8.2	
SP2				(*1)	1			8.4	
SP3				(*1)	1			6.6	
ST1	CONTROLLO CONTROLLER STUEERPANEEL CONTROLE CONTROL CONTROLO			4151679A4 4151679A8(*)	1	MW320021 ENERGY 210BA	ELIWELL	6.2	
ST2	CONTROLLO (OPTIONAL) CONTROLLER (OPTIONAL) STUEERPANEEL (OPTIONAL) CONTROLE (OPTION) CONTROL (OPCION) CONTROLO (OPCION)			4151687	1	MW320600	ELIWELL	7.9	
TC1	TRASFORMATORE TRANSFORMER TRANSFORMATOR TRANSFORMATEUR TRANSFORMADOR TRANSFORMADOR			(*2)	1			5.6	

Variazioni		Data	Nome	Des.		Dis. N.	Luogo	Impianto
a							960H516/517/518	A
b			A. S.					
c		Dis.		Prog.		Revisione	REV.0 * 23.05.01 * A. S.	Pg. 19
d		Ver.		CH50-90/180-280/380-480				20



P.I.O.VAN

UFFICIO TECNICO

1	2	3	4	5	6	7	8	9	10
SIGLA	DESCRIZIONE			CODICE	Q. TA'	MODELLO	COSTRUTTORE	RIF.	
POS.	DESCRIPTION			CODE	Q. TY'	TYPE	MANUFACTURER	REF.	
SIGEL	BESCHREIBUNG			CODE	ANZ.	TYPE	HERSTELLER	BEZUG	
POS./PIECE	DESCRIPTION			CODE/PIECE	Q. TY'	TYPE	MANUFACTURER	REF.	
	MODELE/COMPOSANT			DE RECHANGE					
SIGLA	DESCRIPCION			CODIGO	CANTIDAD	MODELO	CONSTRUCTOR	REF.	
SIGLA	DESCRICA0			CODIGO	Q. DE	TIPO	FABRI CANTE	REF.	

YV1	ELETTROVALVOLA GAS LIQUIDO			(*1)	1			7.2	
	GAS SOLENOID VALVE								
	SPULE MAGNETVENTIL GAS								
	ELECTROSOUPAPE GAZ								
	ELECTROVALVULA GAS								
	BOBINA DA VALVULA ELETRICA DO GAS								
	ELETTROVALVOLA GAS CALDO (OPTIONAL)								
	HOT GAS SOLENOID VALVE (OPTIONAL)								
	SPULE MAGNETVENTIL GAS (OPTIONAL)								
	ELECTROSOUPAPE GAZ (OPTION)								
	ELECTROVALVULA GAS (OPCIONAL)								
	BOBINA DA VALVULA ELETRICA DO GAS (OPCIONAL)								
N. B. :	(*1)								
	CODICI PARTI DI RICAMBIO NELLA SEZIONE MECCANICA DEL MANUALE.								
	PART CODE TO LOOK FOR IN THE MECHANICAL SECTION OF THIS MANUALD.								
	DIE CODES DER ERSATZTEILE SIND IM MECHANISCHEN TEIL DES HANDBUCHES ENTHALTEN.								
	CODES RELATIFS AUX PIECES DE RECHANGE A IDENTIFIER DANS LA PARTIE MECANIQUE DU LIVRET D' INSTRUCTION.								
	LOS CODIGOS DE ESTAS PIEZAS DE REPUESTO SE TIENEN QUE BUSCAR EN LA SECCION MECANICA DEL MANUAL.								
	OS CODIGOS DAS PECAS SOBRESSALENTES DEVEM SER PROCURADOS NA SECAO MECANICA DO MANUAL.								
N. B. :	(*2)								
	VEDERE TAB. 01/02/03								
	SEE TAB. 01/02/03								
	SIEHE TAB. 01/02/03								
	VOIR TAB. 01/02/03								
	VEASE TAB. 01/02/03								
	VEJA TAB. 01/02/03								

Variazioni	Data	Nome	Data	Nome	Des.	Dis. N.	Luogo	Impianto
a			23.05.01	A. S.			960H516/517/518	A
b								
c								
d								