

GREG SMITH

Equipment



(800) 673-8740

www.GregSmithEquipment.com

TWO POST LIFTS

WE ARE NOT RESPONSIBLE FOR MISPRINTS.
PRICES AND SPECIFICATIONS ARE SUBJECT TO CHANGE.

ELITE 9KOH

The Elite 9KOH is the perfect choice for those customers who demand the most lifting capacity at the lowest possible price. The overhead beam can be adjusted to two different height settings: 11' 6" or 11' 10".

LIGHT COMMERCIAL GRADE

IN STORE PICK-UP PRICE
\$1495

FEATURES

- 9,000 lb. Capacity
- Light Commercial Grade
- Dual Point Lock Release
- Symmetric Columns
- Asymmetric Arm Design
- Automatic Arm Restraints
- Clear Floor Design
- Powder Coat Finish
- FREE Truck Adapters
- Mounting Hardware
- 1-Year Structural, 1-Year Hydraulic Warranty



Atlas 9KOH Specifications

Capacity	9,000 lb.
Overall Height	142" (11' 10") Or 138" (11' 6")
Overall Floor Width	134 1/4" (11' 2 1/4")
Maximum Lift Height	80 1/4" (6' 8 1/4")
Inside Column	109 3/4" (9' 1 3/4")
Shipping Weight	1,500 lb.

PRICES SUBJECT TO CHANGE
VISIT OUR WEBSITE
FOR CURRENT PRICING
AND SPECIALS

Atlas Single Screw-Up Adapters

Optional adjustable single screw-up lift pads are now available for all Atlas two post lifts. Screw-up adapters allow the operator to "precisely position" the lift pad in direct contact with the vehicle's lifting points. Please make sure of your arm hole size before you order.



Starting At
\$199
8 Piece Kit

ATPK-S-SCREW-KIT1

3 Different
Kits On Our
Website



90HSC-SS

The Atlas 90HSC-SS features single piece columns and extra long carriages. The Atlas 90HSC-SS two-post above ground lift is the perfect choice for smaller repair facilities or Mr. Homeowner who demands the highest quality at the absolute best price.



COMMERCIAL GRADE

Atlas 90HSC-SS Specifications

Capacity	9,000 lb.
Overall Height	142" (11' 10")
Overall Floor Width	134" (11' 2")
Maximum Lift Height	81 3/8" (6' 9 3/8")
Inside Column	109 1/2" (9' 1 1/2")
Shipping Weight	1,450 lb.

IN STORE PICK-UP PRICE
\$1795
OR
\$2045
W/ SHIPPING INCLUDED

FEATURES

- 9,000 lb. Capacity
- Light Commercial Grade
- Dual Hydraulic Chain-Over Cylinders
- Single Piece Columns
- Single-Point Lock Release
- Symmetric Columns
- 3-Stage Super-Symmetric Front Arms
- Powder Coat Finish
- Clear Floor Design
- FREE Truck Adapters
- Mounting Hardware
- 5-Year Structural Warranty, 1-Year Hydraulic Warranty

Atlas RimRod Mountable Wheel Holders For Lift Arms



The RimRod tire/wheel support attaches to most above ground lift arms. Visit our website for product dimensions.

IN STORE PICK-UP PRICE
\$69
OR
\$84
W/ SHIPPING INCLUDED
For One

IN STORE PICK-UP PRICE
\$239
OR
\$255
W/ SHIPPING INCLUDED
Set of Four



PV-9P

COMMERCIAL GRADE

The Atlas PV-9P is a commercial grade two post lift that incorporates the same arm and carriage design as our Industry leader PV-10P. The PV-9P has symmetric columns and specially designed arms that can be set in either the symmetric or asymmetric position. The PV-9P has dual direct drive cylinders and single point lock release.



IN STORE PICK-UP PRICE
\$2095
OR
\$2345
W/ SHIPPING INCLUDED

WATCH OUR
VIDEO
ONLINE

FEATURES

- Commercial Grade
- Direct Drive Cylinders
- Single-Point Lock Release
- Front Arms May Be Configured Symmetric Or Asymmetric
- "Padded" Shut-Off Bar
- Powder Coat Finish
- Adjustable Height
- Clear Floor Design
- FREE Truck Adapters
- Mounting Hardware
- 5-Year Structural, 2-Year Hydraulic Warranty

Atlas PV-9P Specifications

Capacity	9,000 lb.
Overall Height	142 1/2" - 150 1/2" (11' 10 1/2" - 12' 6 1/2")
Overall Floor Width	135" (11' 3")
Maximum Lift Height	80 1/2" (6' 8 1/2")
Inside Column	112 1/4" (9' 4 1/4")
Shipping Weight	1,500 lb.

PV-9P Width Extension Kit

Adds 6 inches to the overall width of the Atlas PV-9P.

ATPK-PV9P-WKIT

IN STORE PICK-UP PRICE

\$129

Add 6 Inches To
Overall Width



Increase The Width Of Your Existing PV-9P!



PV-9HP EXTRA TALL

The Atlas PV-9HP is the taller version of our PV-9P two post above ground lift.

Adjustable From 13' 10 1/2" To 14' 6 1/2"

Atlas PV-9HP Specifications

Capacity	9,000 lb.
Overall Height	166 1/2" - 174 1/2" (13' 10 1/2" - 14' 6 1/2")
Overall Floor Width	135" (11' 3")
Maximum Lift Height	81 3/4" (6' 9 3/4")
Inside Column	112 1/4" (9' 4 1/4")
Shipping Weight	1,650 lb.

2 Feet Taller!

IN STORE PICK-UP PRICE
\$2295
OR
\$2545
W/ SHIPPING INCLUDED

**Perfect For High
Profile Vehicles**



PV-10P

The Atlas PV10P is a commercial grade two-post lift designed to lift a wide variety of vehicles. The PV10P has a low pad height to accommodate passenger vehicles but is built to handle full size pickups. The PV10P has dual direct drive cylinders and single-point lock release.



IN STORE PICK-UP PRICE
\$2245
OR
\$2495
W/ SHIPPING INCLUDED

FEATURES

- Commercial Grade
- Direct Drive Cylinders
- Single-Point Lock Release
- Front Arms May Be Configured Symmetric Or Asymmetric
- "Padded" Shut-Off Bar
- Powder Coat Finish
- Adjustable Height
- Clear Floor Design
- FREE Truck Adapters
- Mounting Hardware
- 5-Year Structural, 2-Year Hydraulic Warranty

Atlas PV-10P Specifications

Capacity	10,000 lb.
Overall Height	Low: 142" (11' 10") High: 146" (12' 2")
Overall Width	137 3/8" (11' 5 3/8")
Maximum Lift Height	82" (6' 10")
Between Columns	110 3/4" (9' 2 3/4")
Shipping Weight	1,900 lb.

COMMERCIAL GRADE

PV-10P Height Extension Kit

Add 2 Feet To Overall Height To Your Existing PV-10P

IN STORE PICK-UP PRICE
\$350
OR
\$475
W/ SHIPPING INCLUDED
ATPK-PV10PX-EXT



OH-10X

EXTRA WIDE EXTRA TALL

This commercial grade two-post lift is the perfect choice for garages that demand the highest quality at the absolute best price. The Atlas OH10X is **WIDER** and **TALLER** than most above ground two-post lifts. The OH10X has dual direct drive cylinders and single-point lock release.



IN STORE PICK-UP PRICE
\$2295
OR
\$2545
W/ SHIPPING INCLUDED

FEATURES

- Commercial Grade
- Direct Drive Cylinders
- 2-Stage Heavy Duty Symmetric Arms
- Single Piece Columns
- Symmetric Columns
- Extra Long Carriages
- Powder Coat Finish
- 10,000 lb. Capacity
- Clear Floor Design
- FREE Truck Adapters
- Mounting Hardware
- 5-Year Structural, 2-Year Hydraulic Warranty

Atlas OH-10X Specifications

Capacity	10,000 lb.
Overall Height	151 1/2" (12' 7 1/2")
Overall Floor Width	143 3/8" (11' 11 3/8")
Max Lift Height	84" (7')
Inside Column	117 1/2" (9' 9 1/2")
Shipping Weight	1,800 lb.

COMMERCIAL GRADE

Atlas Wheel Stands

The Atlas Wheel Stands can support up to 6,000 lbs. and are the perfect choice for those smaller shops who want the advantages of a four post lift but have only limited floor space. Turntables can be placed on the wheel stands to turn any two-post lift into an alignment lift. *Turntables Sold Separately



IN STORE PICK-UP PRICE
\$1295
OR
\$1495
W/ SHIPPING INCLUDED



APEX 10

The Atlas APEX-10 was engineered and built to offer a commercial grade above ground lift to those customers who have "fallen in love" with the Double S column design. The Atlas APEX-10 can be installed with the columns positioned symmetrically. This offers easy vehicle access and superior vehicle lift point support due to the three stage front arm design.

IN STORE PICK-UP PRICE
\$2345
OR
\$2595
W/ SHIPPING INCLUDED



COMMERCIAL GRADE

Includes These **FREE** Accessories:



TALLER VERSION AVAILABLE

Direct Drive Cylinders

Double S Column Design

FEATURES

- Commercial Grade
- Double S Column Design
- Direct Drive Cylinders
- Single-Point Lock Release
- Symmetric Columns
- "Padded" Shut-Off Bar
- Powder Coat Finish
- Adjustable Height
- Clear Floor Design
- FREE Truck Adapters
- FREE Screw-Up Adapters
- Mounting Hardware
- 5-Year Structural, 2-Year Hydraulic Warranty

Atlas APEX 10 Specifications

Capacity	10,000 lb.
Overall Height	Low: 135 7/8" (11' 3 7/8")* High: 139 7/8" (11' 7 7/8")
Overall Height w/ Cylinder	142 1/2" (11' 10 1/2")
Overall Width	139" (11' 7")
Max Lift Height (w/ adapters)	81 1/2" (6' 9 1/2")
Shipping Weight	1,750 lb.

WATCH OUR VIDEO ONLINE

*Requires spacers

What ALI Certified Really Means



ALI (Automotive Lift Institute) governs the safety standards for automotive lifts in the U.S. ALI Certified lifts must all pass the exact same testing, material and operational standards. This testing covers the structural integrity, proper control function and even overloading the lift beyond its rated capacity. The procedures are PASS - FAIL. Either you get the sticker or you do not. Rotary, Forward, Mohawk and ATLAS Certified Lifts are all subject to the exact same production and testing standards.

If a product carries the ALI Gold Label you can be assured that the equipment and the manufacturing facility it is produced in are in compliance with the ALI Standard. The facilities are audited at least two times, yearly, to guarantee the process and product adhere to the ALI Guidelines.

IBC or International Building Code is in use in all 50 States. This Code states that for every region governed by IBC, automotive lifts must adhere to the ALI Standard in order to obtain permits for lift installation in new construction buildings.



APEX 10H



IN STORE PICK-UP PRICE
\$2545
OR
\$2795
W/ SHIPPING INCLUDED

ALI Certified

TWO POST LIFTS

WE ARE NOT RESPONSIBLE FOR MISPRINTS.
PRICES AND SPECIFICATIONS ARE SUBJECT TO CHANGE.



PV-12P EXTRA WIDE EXTRA TALL

The Atlas PV-12P and PV-15P are commercial grade lifts designed to accommodate heavy, long wheel base trucks. The low pad height on the PV-12P allows the operator to lift both cars and trucks. The larger arms and taller pad height on the PV-15P are designed for customers who primarily work on trucks and SUVs. The extra distance between the columns accommodates wider vehicles or vehicles with wide rear-view mirrors. The extra height is perfect for tall vans and box trucks.

IN STORE PICK-UP PRICE
\$2995
OR
\$3345
W/ SHIPPING INCLUDED



FEATURES

- Commercial grade
- Single point lock release
- Symmetric design
- Powder coat finish
- Adjustable to three (3) heights
- Free 12 piece truck adapter set
- Anchor bolts included
- 5 Year Structural Warranty, 2 Year Hydraulic Warranty

PRICES SUBJECT TO CHANGE
VISIT OUR WEBSITE
FOR CURRENT PRICING
AND SPECIALS



PV-15P EXTRA WIDE EXTRA TALL



IN STORE PICK-UP PRICE
\$3495
OR
\$3845
W/ SHIPPING INCLUDED

Visit Our Website
FOR MORE
Product Photos

Atlas PV-12P Specifications

	Low	Middle	High
Capacity	12,000 lb.		
Overall Height	148 1/2" (12' 4 1/2") [‡]	163 1/2" (13' 7 1/2")	175 1/2" (14' 7 1/2")
Height To Shut Off Bar	142" (11' 10") [‡]	157" (13' 1")	169" (14' 1")
Overall Width	158" (13' 2")		
Maximum Lift Height (With Truck Adapters)	82" (6' 10")		
Between Columns	122 5/8" (10' 2 5/8")		
Drive Thru	108 5/8" (9' 5/8")		
Motor/Electrical Re- quirement	220 Volt Single (1) Phase; A 30 amp Breaker Is Recommended		
Shipping Weight	2,250 lb.		

[‡] Requires purchase of additional shorter cables

Atlas PV-15P Specifications

	Low	Middle	High
Capacity	15,000 lb.		
Overall Height	150 3/8" (12' 6 3/8") [‡]	162 3/8" (13' 6 3/8")	177 3/8" (14' 9 3/8")
Height To Shut Off Bar	140 3/4" (11' 8 3/4") [‡]	152 3/4" (12' 8 3/4")	167 3/4" (13' 11 3/4")
Overall Width	158" (13' 2")		
Maximum Lift Height (With Truck Adapters)	79 3/4" (6' 7 3/4")		
Between Columns	122 5/8" (10' 2 5/8")		
Drive Thru	109" (9' 1")		
Motor/Electrical Re- quirement	220 Volt, Single (1) Phase; A 30 amp Breaker Is Recommended		
Shipping Weight	2,600 lb.		



APEX 12

The Atlas Apex 12 is an ALI CERTIFIED overhead two-post lift with two adjustable height settings and single point lock release.



IN STORE PICK-UP PRICE
\$3195
OR
\$3495
W/ SHIPPING INCLUDED



ALI
Certified

FEATURES

- Commercial Grade
- Direct Drive Cylinders
- Single-Point Lock Release
- "Padded" Shut-Off Bar
- Powder Coat Finish
- Adjustable Height
- Clear Floor Design
- FREE Truck Adapters
- FREE Screw-Up Adapters
- Mounting Hardware
- Professional Grade Arm Lock Restraint System

Atlas APEX 12 Specifications

Capacity	12,000 lb.
Overall Height	Low: 165" (13' 9") High: 177" (14' 9")
Overall Width	155 3/4" (12' 11 3/4")
Max Lift Height	86" (7' 2")
Drive Thru	109 2/3" (9' 1 2/3")
Shipping Weight	2,100 lb.



APEX 15

The Atlas Apex 15 is an ALI CERTIFIED, commercial grade, overhead two-post lift designed to accommodate both long wheel base trucks and passenger cars.



IN STORE PICK-UP PRICE
\$4795
OR
\$4995
W/ SHIPPING INCLUDED



ALI
Certified

COMMERCIAL
GRADE

FEATURES

- Commercial Grade
- Direct Drive Cylinders
- Single-Point Lock Release
- "Padded" Shut-Off Bar
- Powder Coat Finish
- Clear Floor Design
- FREE Truck Adapters
- FREE Screw-Up Adapters
- Mounting Hardware
- Professional Grade Arm Lock Restraint System

Atlas APEX 15 Specifications

Capacity	15,000 lb.
Overall Height	174 1/2" (14' 6 1/2")
Overall Width	154 1/2" (12' 10 1/2")
Max Lift Height	87 1/2" (7' 3 1/2")
Drive Thru	107 1/2" (8' 11 1/2")
Shipping Weight	2,400 lb.



Atlas 18K

ALI Certified

The ALI CERTIFIED Atlas 18,000 lb capacity heavy duty two post lift meets the highest European and American Lift Institute standards. This electro-hydraulic lift features the finest design, engineering, and manufacturing that has made the Atlas brand a globally recognized stamp of quality. Includes safety lowering valve, mechanical safety latch, synchronization cables, and high quality steel to ensure a safe and powerful lift system. Arms, adapters, and carriages are usually the first components to show excessive signs of wear on a low quality lift. Atlas takes important steps to ensure that our components stay working correctly and safely for years to come.



IN STORE PICK-UP PRICE
\$9995
OR
\$10345
W/ SHIPPING INCLUDED

80" Maximum Lifting Height



BP-8000

The Atlas BP8000 is a base-plate two-post lift designed for low ceiling garages. The total column height is 108" (9 feet.) This lift features a single-point lock release.

IN STORE PICK-UP PRICE
\$1495
OR
\$1745
W/ SHIPPING INCLUDED



Visit Our Website
**FOR MORE
Product Photos
AND DETAILED SPECIFICATIONS**

PRICES SUBJECT TO CHANGE
VISIT OUR WEBSITE
FOR CURRENT PRICING
AND SPECIALS

FEATURES

- 8,000 lb. Capacity
- Dual Hydraulic Chain-Over Cylinders
- Single-Point Lock Release
- 3-Stage Super-Symmetric Front Arms
- Automatic Arm Restraints
- Base-Plate Design
- Powder Coat Finish
- FREE Truck Adapters
- Mounting Hardware
- 5-Year Structural, 2-Year Hydraulic Warranty

Atlas BP-8000 Specifications

Capacity	8,000 lb.
Overall Height	108" (9')
Overall Floor Width	132" (11')
Maximum Lift Height	81 3/8" (6' 9 3/8")
Inside Column	109 5/8" (9' 1 5/8")
Shipping Weight	1,350 lbs.

ELITE 9KBP

The Elite 9KBP is a base-plate two-post lift designed for low ceiling garages. The total column height of 111 1/2" (9' 3 1/2") allows this lift to be installed in almost any professional or home garage with a ceiling as low as 9' 6".



IN STORE PICK-UP PRICE
\$1495

LIGHT COMMERCIAL GRADE

Elite 9KBP Specifications

Capacity	9,000 lb.
Overall Height	111 1/2" (9' 3 1/2")
Overall Floor Width	134 1/2" (11' 2 1/2")
Maximum Lift Height	81" (6' 9")
Inside Column	110" (9' 2")
Shipping Weight	1,450 lbs.

FEATURES

- 9,000 lb. Capacity
- Light Commercial Grade
- Dual Point Lock Release
- Symmetric Arms
- Symmetric Columns
- Automatic Arm Restraints
- Base-Plate Design
- Designed For Low Ceiling Clearance
- FREE Truck Adapters
- Mounting Hardware
- Powder Coat Finish
- 1-Year Structural, 1-Year Hydraulic Warranty



BP-10000

The Atlas BP-10000 commercial grade 2 post lift is built for those customers who want to lift heavy vehicles in a low ceiling garage.



COMMERCIAL GRADE

IN STORE PICK-UP PRICE
\$2295
OR
\$2545
W/ SHIPPING INCLUDED

Atlas BP-10000 Specifications

Capacity	10,000 lb.
Overall Height	111 7/8" (9' 3 7/8")
Overall Floor Width	139 1/8" (11' 7 1/8")
Maximum Lift Height	86 3/8" (7' 2 3/8")
Inside Column	112 1/4" (9' 4 1/4")
Shipping Weight	1,640 lbs.

FEATURES

- 10,000 lb. Capacity
- Dual Hydraulic Chain-Over Cylinders
- Single-Point Lock Release
- Automatic Arm Restraints
- 3-Stage Super-Symmetric Front Arms
- Base-Plate Design
- Powder Coat Finish
- FREE Truck Adapters
- Mounting Hardware
- 5-Year Structural, 2-Year Hydraulic Warranty

Atlas Frame Adapters

The optional rear frame adapter set (2 pieces) is available for most of our Atlas line of 2-post lifts.



IN STORE PICK-UP PRICE
\$49
per set

Works Great
For Ford®
Trucks!



APEX 9BP

The Atlas Apex 9BP is an ALI CERTIFIED baseplate two-post lift designed for low ceiling garages. The total column height is 111 1/8" (9' 3 1/8").



ALI
Certified



PERFECT FOR LOW CEILING!

IN STORE PICK-UP PRICE
\$2245
OR
\$2495
W/ SHIPPING INCLUDED

FEATURES

- 9,000 lb. Capacity
- Dual Hydraulic Chain-Over Cylinders
- Symmetric Arms
- Base-Plate Design
- Powder Coat Finish
- Mounting Hardware
- FREE Truck Adapters
- Dual Point Lock Release
- Automatic Arm Restraints
- Secondary Lock System (SLS)

Atlas APEX 9BP Specifications

Capacity	9,000 lb.	Maximum Lift Height	74 5/6" (6' 2 5/6")
Overall Height	111 1/8" (9' 3 1/8")	Drive Thru	97 1/3" (8' 1 1/3")
Overall Floor Width	138 3/5" (11' 6 3/5")	Shipping Weight	1,700 lbs.



BP-12000

The Atlas BP-12K base-plate style lift is equipped with single-point lock release – a very unique feature for a base-plate style lift. With an overall column height of 9' 3" the BP-12K is the ideal solution for a garage with low ceilings.



COMMERCIAL GRADE

IN STORE PICK-UP PRICE
\$2995
OR
\$3345
W/ SHIPPING INCLUDED

Atlas BP-12000 Specifications

Capacity	12,000 lb.
Total Ceiling Height Required	122 1/2" (10' 2 1/2")
Overall Height	111 1/4" (9' 3 1/4")
Overall Floor Width	150 3/4" (12' 6 3/4")
Maximum Lift Height	80 3/4" (6' 8 3/4")
Inside Column	123 1/2" (10' 3 1/2")
Shipping Weight	2,300 lbs.

FEATURES

- 12,000 lb. Capacity
- Dual Hydraulic Chain-Over Cylinders
- Single-Point Lock Release
- Automatic Arm Restraints
- 3-Stage Symmetric Arms
- Base-Plate Design
- Powder Coat Finish
- FREE Truck Adapters
- Mounting Hardware
- 5-Year Structural, 2-Year Hydraulic Warranty

FOUR POST PORTABLE LIFTS

WE ARE NOT RESPONSIBLE FOR MISPRINTS. PRICES AND SPECIFICATIONS ARE SUBJECT TO CHANGE.



Atlas Garage Pro 8000

The Atlas Garage Pro 8000 is one of our most popular 4-post lifts. These 8,000 lb. capacity lifts feature a lock ladder column design with a single point lock release.

67 1/2" Clearance Under Runways

IN STORE PICK-UP PRICE
\$1995
 OR
\$2345
 W/ SHIPPING INCLUDED

Specifications

Capacity	8,000 LB
Overall Width without Motor	104 1/2" (8' 8 1/2")
Overall Length without Approach Ramps	175 1/2" (14' 7 1/2")
Maximum Wheel Base	153 1/2" (12' 9 1/2")

FEATURES

- 8,000 lb. capacity
- Powder coat finish
- Diamond plated runways
- Single point lock release
- Caster kit with polyurethane wheels
- Steel approach ramps included
- Steel jack tray included
- Plastic drip trays included
- Four steel wheel stops included
- Two rubber wheel chocks included
- Perfect for storing or working on vehicles
- 2 year structural, 1 year hydraulic warranty



Atlas Garage Pro 8000 EXT

The Atlas Garage Pro 8000 EXT is a true 8,000 LB. four post lift. The Atlas Garage Pro 8000 EXT incorporates many of the great features of both the Atlas Garage Pro 8000 and the Atlas Garage Pro 9000.

IN STORE PICK-UP PRICE
\$2195
 OR
\$2545
 W/ SHIPPING INCLUDED

11 1/2" TALLER!
 Than The Garage Pro 8000



79" Clearance Under Runways

No Need To Bolt Down!



Atlas Garage Pro 8000 EXT-L

EXTRA TALL EXTRA LONG!

IN STORE PICK-UP PRICE
\$2395
 OR
\$2745
 W/ SHIPPING INCLUDED

FEATURES

- 8,000 lb. Capacity
- Powder Coat Finish
- Diamond Plated Runways
- Four Drip Trays Included
- Single Point Lock Release
- Steel Approach Ramps Included
- Caster Kit Included
- Perfect For Storing Or Working On Vehicles

Specifications

Clearance Under Runways	80" (6' 8")
Overall Width (Without Motor)	104 3/4" (8' 8 3/4")
Overall Length (Without Approach Ramps)	195" (16' 3")
Height of Columns (Including Bolts)	100" (8' 4")
Lifting Height	84 1/4" (7' 1/4")
Runway Width	22 1/2" (1' 10 1/2")
Runway Length	185" (15' 5")

LIGHT COMMERCIAL GRADE



The Atlas Garage Pro 8000, 8000EXT, 8000EXT-L, And 9000 Include these FREE accessories!

WHEEL CHOCKS



JACK TRAY



4 DRIP TRAYS



CASTER KIT



Atlas Garage Pro 9000

A portable lift that can accommodate a dual-wheel truck. Long runways support a long wheel base, crew cab dually.

LIGHT COMMERCIAL GRADE

FEATURES

- Light commercial grade
- Ladder lock system
- Steel approach ramps included
- Powder coat finish
- 9,000 lb. capacity
- Single point lock release
- Extra height AND width
- Polyurethane wheels on caster kit
- Four wheel stops included
- Perfect for storing or working on vehicles
- 2 year structural, 1 year hydraulic warranty

No Need To Bolt Down!
80 1/2" Clearance Under Runways

IN STORE PICK-UP PRICE
\$2795
 OR
\$3145
 W/ SHIPPING INCLUDED

Specifications

Capacity	9,000 LB.
Clearance under Runways	80 1/2" (6' 8 1/2")
Between Columns	109 1/2" (9' 1 1/2")
Maximum Wheel Base	187" (15' 7")
Shipping Weight	2,300 lb.



EXTRA TALL EXTRA WIDE EXTRA LONG!



SAVE BIG \$\$\$
 When You Buy A 4-Post Lift And Add 2 Rolling Jacks



The Atlas Apex 8 is an ALI CERTIFIED four post hobbyist lift. This 8,000 lb. capacity lift was designed for storage and light vehicle maintenance and built for use by Mr. Homeowner or restoration shops.

ALI Certified



Perfect For Storing Or Working On Vehicles

WATCH OUR VIDEO ONLINE

IN STORE PICK-UP PRICE
\$2545
OR
\$2895
W/ SHIPPING INCLUDED



FEATURES

- 8,000 lb. capacity
- Powder coat finish
- Lock Ladder Design
- Single point lock release
- Free Caster set included
- Double Lock Safety System
- Steel approach ramps included
- Four steel wheel stops included
- Two rubber wheel chocks included

Atlas APEX 8 Specifications

Clearance Under Runways	67 1/2" (5' 7 1/2")
Overall Width (Without Motor)	114 1/2" (9' 6 1/2")
Overall Length (Without Approach Ramps)	186 1/2" (15' 6 1/2")
Height of Columns (Including Bolts)	87 1/2" (7' 3 1/2")
Runway Length	165 1/2" (13' 9 1/2")
Runway Width	18 3/4" (1' 6 3/4")



ST-7000

This is THE lift to have for the customer who has extra tall ceilings and need to store regular height vehicles on top of extra tall vehicles.

IN STORE PICK-UP PRICE
\$4995

SUPER TALL



Perfect For Storing Above Tall Vehicles

SUPER TALL 12' 3" LIFTING HEIGHT!

ST-7000 Specifications

Lifting Height To Top Of Runway	147" (12' 3")
Height of Columns	162" (13' 6")
Clearance Under Runways	142" (11' 10")
Clearance Between Columns	100" (8' 4")
Runway Length	194" (16' ")

7000 LB CAPACITY

WATCH OUR VIDEO ONLINE

4-Post Commercial Service Lifts



Atlas 412



Atlas 414

Atlas lifts are designed and built to commercial grade standards, providing you with many years of service. Our Atlas lifts offer many exclusive features not found on many other competitors' lifts.



IN STORE PICK-UP PRICE
\$3195
OR
\$3645
W/ SHIPPING INCLUDED

186 1/2" Runway Length

COMMERCIAL GRADE

Add 2 Rolling Jacks And Save Big \$\$\$ On A Combo Deal

Specifications

Capacity	12,000 LB.
Lifting Height	75 1/2" (6' 3 1/2")
Shipping Weight	2,650LB.

VISIT OUR WEBSITE FOR YOUR BEST DEAL
www.GregSmithEquipment.com

IN STORE PICK-UP PRICE
\$3695
OR
\$4145
W/ SHIPPING INCLUDED

COMMERCIAL GRADE



207" Runway Length

Specifications

Capacity	14,000 LB.
Lifting Height	74" (6' 2")
Shipping Weight	3,200LB.

Visit Our Website FOR MORE Product Photos AND DETAILED SPECIFICATIONS

Optional Equipment For 412/412A And 414/414A

Drive-Off Ramps

The heavy duty diamond plated Atlas drive-off ramps make the perfect addition to your existing Atlas 414/414A or 412/412A 4-post lift system. These ramps give you the option to "drive through" the lift rather than "backing off" the lift. The ramp kit contains all the necessary hardware for installation.

412/412A
IN STORE PICK-UP PRICE
\$199
Set Of 2

414/414A
IN STORE PICK-UP PRICE
\$299
Set Of 2

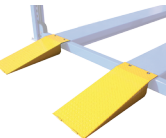

2-Foot Front Extension Kits

Add 24" To Your Existing Runway!

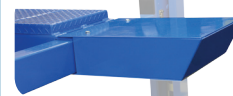

For Use With: Atlas 412, 412A, 414, And 414A

IN STORE PICK-UP PRICE
\$495
Set Of 2

ATLAS EQUIPMENT **APEX 14**

The Atlas Apex 14 is an ALI CERTIFIED four post commercial grade lift is built for years of dependable service for the busiest of automotive shops.

IN STORE PICK-UP PRICE
\$3995
 OR
\$4445
 W/ SHIPPING INCLUDED



**Alignment Kit
 Accessory Available**

ATTD-APEX-ALIKIT

ALI Certified

Visit Our Website
**FOR MORE
 Product Photos**



COMMERCIAL GRADE

Specifications

Capacity	14,000 LB.
Lifting Height	76 1/2" (6' 4 1/2")
Overall Height	92 1/2" (7' 8 1/2")
Runway Length	205 1/2" (17' 1 1/2")
Shipping Weight	2,800 LB.

ATLAS EQUIPMENT **Atlas 412A**

Atlas alignment lifts are designed and built to commercial grade standards and will provide many years of service. Our Atlas alignment lifts offer many exclusive features not found on many other competitors' lifts.

COMMERCIAL GRADE



IN STORE PICK-UP PRICE
\$4095
 OR
\$4545
 W/ SHIPPING INCLUDED



Specifications

Capacity	12,000 LB.
Lifting Height	76 1/4" (6' 4 1/4")
4-Wheel Alignment Wheelbase	Maximum 154"
2-Wheel Alignment Wheelbase	Maximum 157"
Shipping Weight	2,950 LB.

ATLAS EQUIPMENT **Atlas 414A**

Atlas alignment lifts are designed and built to commercial grade standards and will provide many years of service. Our Atlas alignment lifts offer many exclusive features not found on many other competitors' lifts.

IN STORE PICK-UP PRICE
\$4695
 OR
\$5145
 W/ SHIPPING INCLUDED



COMMERCIAL GRADE

Specifications

Capacity	14,000 LB.
Lifting Height	76 1/4" (6' 4 1/4")
4-Wheel Alignment Wheelbase	Maximum 172 1/2"
2-Wheel Alignment Wheelbase	Maximum 175 1/2"
Shipping Weight	3,500LB.

FEATURES

- Air operated single point lock release
- Diamond Plate Runway Surface
- Mounting Hardware Included
- Flush-mounted alignment slip plates and recessed areas in the runways for turntables
- 5 Year Structural, 2 Year Hydraulic Warranty

ATLAS EQUIPMENT **Atlas 14KOF-EXT Open Front Alignment Lift**

The Atlas 14KOF-EXT Garage Pro four post commercial grade open front alignment lift is built for years of dependable service for the busiest of automotive shops. The Atlas 14KOF-EXT Garage Pro open front alignment lift has 2 wheel alignment wheel base capabilities of 187 inches. The Atlas 14KOF-EXT Garage Pro has built in slip plates and recessed areas in the runways to allow for turntables

COMMERCIAL GRADE



EXTRA LONG!

FEATURES

- Four Post Open Front Alignment Lift
- 14,000 LB. lifting capacity
- Recessed areas in the runways for turntables
- Built In rear slip-plates
- Air operated double lock system

**223" (18' 7")
 Runway Length**

IN STORE PICK-UP PRICE
\$6495
 OR
\$7995
 W/ SHIPPING INCLUDED

SAVE BIG \$\$\$
 When You Buy A 4-Post Lift
 And Add 2 Rolling Jacks



No Crossbar Open Front

Specifications

Capacity	14,000 LB.
Lifting Height	69 7/8" (5' 9 7/8")
4-Wheel Alignment Wheelbase	Maximum 162"
2-Wheel Alignment Wheelbase	Maximum 187"
Runway Length	223" (18' 7")
Shipping Weight:	3,500 lb.

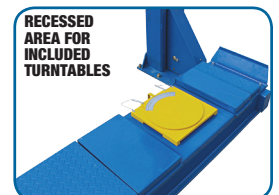

WE ARE NOT RESPONSIBLE FOR MISPRINTS.
PRICES AND SPECIFICATIONS ARE SUBJECT TO CHANGE.

SCISSOR ALIGNMENT LIFTS



12ASL Alignment Scissor Lift

Specifications

Lifting Capacity	12,000 LB
Lifting Height	84 1/4" (7' 1/4")
4-Wheel Alignment Wheelbase	Max. 168" - Min. 90"
2-Wheel Alignment Wheelbase	Max. 172" - Min. 86"
Motor	220 Volt, 1 Phase
Shipping Weight	5000 lb.

FEATURES

- Can be surfaced mounted or flush mounted
- Very precise platform leveling accuracy
- Mechanical safety lock with air operated engagement and release
- Emergency manual pump for lowering
- Overload valve included
- Lowering speed control valve included
- Extra Long Slip Plates allow for aligning of wheelbases from 86" to 172"

IN STORE PICK-UP PRICE
\$7995
OR
\$9495
W/ SHIPPING INCLUDED

WATCH OUR VIDEO ONLINE!

COMMERCIAL GRADE



*Professional Installation Recommended

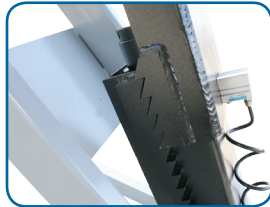

Air Operated Locking System

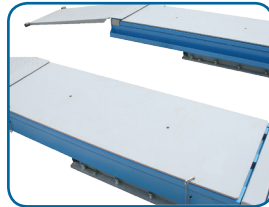

Flush Mounted Slip Plates



Recessed Area For Turntables

INCLUDES TURNABLES
Color May Vary



12AWFSL

Atlas alignment scissor lifts are the perfect choice for customers who have limited bay space. This lift is comparable to other lifts costing \$15,000 or more.

Specifications

Lifting Capacity	12,000 LB
Lifting Height	84 1/4" (7' 1/4")
"Wheels Free" Platform Height	17" (1' 5")
4-Wheel Alignment Wheelbase	Max. 168" - Min. 90"
2-Wheel Alignment Wheelbase	Max. 172" - Min. 86"
Motor	220 Volt, 1 Phase
Shipping Weight	5,400 lb.

IN STORE PICK-UP PRICE
\$9495
OR
\$10995
W/ SHIPPING INCLUDED

Remote Control



*Professional Installation Recommended

Built-in "Wheels Free" System

Visit Our Website
FOR MORE Product Photos AND DETAILED SPECIFICATIONS

COMMERCIAL GRADE

SAVE BIG \$\$\$ When You Buy An Alignment Lift And An Alignment Machine In A Combo Special!



Atlas PX-16A Alignment Scissor Lift

The Atlas PX-16A (16,000 lb. capacity) scissor alignment lift is the perfect choice for those service shops that need a space saving alignment lift to accommodate most all passenger cars up to long up wheel base trucks and extended vans. The Atlas PX-16A allows the operator to perform 4-wheel alignments for vehicles with wheel bases lengths from 95 inches to 204 inches (with front extensions). (184 inches without front extensions) The Atlas PX-16A includes a set of turntables and can be used with (optional) rolling jacks and (optional) air line kit.

FEATURES

- Alignment Scissor Lift
- 16,000 LB. lifting capacity
- Recessed areas in the runways for turntables
- Built in rear slip-plates
- Air operated double lock system

Specifications

Capacity	16,000 LB.
Lifting Height	71 1/2" (5' 11 1/2")
4-Wheel Alignment Wheelbase	Maximum 184"
2-Wheel Alignment Wheelbase	Maximum 188 1/2"
Runway Length	206" (17' 2")
Shipping Weight:	5,000 lb.

Add A Pair Of Rolling Jacks To Your Alignment Lift And SAVE BIG \$\$\$

EXTRA LONG!



See Our Alignment Machine Section

COMMERCIAL GRADE

IN STORE PICK-UP PRICE
\$9995
OR
\$11495
W/ SHIPPING INCLUDED



TOLL FREE **800.673.8740**

Make Wheel Service Easy When You Add A Pair Of Center Jacks To Your 4-Post Or Scissor Alignment Lift!

Add A Pair Of Jacks To Your 4-Post Or Scissor Lift And **SAVE HUNDREDS!**



OUR MANUAL AND AIR/HYDRAULIC OPERATED CENTER JACKS ARE DESIGNED TO WORK WITH MANY DIFFERENT BRANDS OF FOUR (4) POST LIFTS. CHECK OUR WEBSITE TO DETERMINE IF OUR JACKS WILL WORK WITH YOUR FOUR (4) POST LIFT.

Atlas RJ-35

Manual Hydraulic Sliding Jack
XH-PROJACK35

IN STORE PICK-UP PRICE
\$695
OR
\$820
W/ SHIPPING INCLUDED

For Use With:
Atlas Garage Pro 8000,
8000 EXT, 8000 EXT-L,
9000

3,500 lb. Capacity

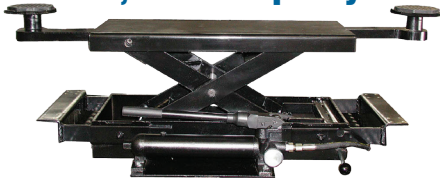

Atlas RJ-45

Manual Hydraulic Rolling Jack
XH-PROJACK45

IN STORE PICK-UP PRICE
\$795
OR
\$920
W/ SHIPPING INCLUDED

For Use With:
Atlas Garage Pro 9000

4,500 lb. Capacity



Atlas RJ-6000

Manual Hydraulic Rolling Jack
ATPK-RJ6BK

IN STORE PICK-UP PRICE
\$795
OR
\$920
W/ SHIPPING INCLUDED

For Use With:
Atlas Garage Pro 9000,
412, 412A, 414, 414A,
14KOF-EXT

6,000 lb. Capacity



Atlas RJ-6000

Air / Hydraulic Rolling Jack
ATPK-RJ6BK-AH-KIT

IN STORE PICK-UP PRICE
\$995
OR
\$1120
W/ SHIPPING INCLUDED

For Use With:
Atlas Garage Pro 9000, 412,
412A, 414, 414A, 14KOF-EXT

6,000 lb. Capacity



Atlas RJ-6

Air / Hydraulic Rolling Jack
ATTD-RJ-6

IN STORE PICK-UP PRICE
\$995
OR
\$1120
W/ SHIPPING INCLUDED

For Use With:
Atlas 12ASL
And 12AWFSL

6,000 lb. Capacity



APEX RJ7

Air / Hydraulic Rolling Jack
ATTD-APEXRJ7

IN STORE PICK-UP PRICE
\$1295

For Use With:
Atlas Apex 14
And Apex 140F

7,000 lb. Capacity



Atlas RJ-8000

Air / Hydraulic Rolling Jack
ATPK-RJ8BKNP-AH-KIT

IN STORE PICK-UP PRICE
\$1395
OR
\$1520
W/ SHIPPING INCLUDED

For Use With:
Atlas 414, 414A,
14KOF-EXT, PX-16A

8,000 lb. capacity



Air/Hydraulic Pump Aluminum Reservoir

Convert almost any hydraulic cylinder from hand or foot pump to air powered simply by adding this Atlas® Air/Hydraulic Pump. This Air-Over-Hydraulic Pump features an aluminum 98cc reservoir and a strong design making it great for commercial or home use.

IN STORE PICK-UP PRICE
\$279
OR
\$294
W/ SHIPPING INCLUDED



RM-RAA-1098

Atlas Air/Hydraulic Power Unit

HT3401

IN STORE PICK-UP PRICE
\$140
OR
\$157
W/ SHIPPING INCLUDED

10,000 PSI





LR-06P/LR-10P

LR-06P
6,000 lb. Capacity
IN STORE PICK-UP PRICE
\$1295
OR
\$1545
W/ SHIPPING INCLUDED

The Atlas LR-06P portable 6,000 lb., And the LR-10P portable 10,000 lb. low rise lifts make the perfect addition to any garage that needs a quick method to raise a car to perform wheel service. The Atlas LR-06P and LR-10P low rise lifts come with a rubber top lifting surface and a set of four high density rubber blocks that help to protect the lifting points of most vehicles.

Maximum Lifting Height:
25 1/2"
(w/ positioning blocks)



LR-10P
10,000 lb. Capacity
IN STORE PICK-UP PRICE
\$1695
OR
\$1945
W/ SHIPPING INCLUDED

COMMERCIAL GRADE

FEATURES

- 6,000 OR 10,000 LB. lifting capacities
- Portable
- Low profile design
- Positioning blocks included
- Multiple locking positions
- 110V Power Unit
- Powder Coated
- Commercial Grade



MR-06

The Atlas MR-06 is a free standing 6,000 lb. capacity portable scissor lift. The Atlas MR-06 is the perfect lift for body shops and wheel service specialists that need extra lifting height. This portable lift easily raises a 6,000 LB. car or light truck to a comfortable working height. The unique platform design of the Atlas MR-06 allows access to some areas on the underside of the car not easily accessible with other portable mid-rise lifts.

FEATURES

- 6,000 LB. capacity
- Powder coated finish
- Commercial grade
- Portable design
- 110V power unit
- 3 locking heights
- Extension pad included

IN STORE PICK-UP PRICE
\$1395
OR
\$1645
W/ SHIPPING INCLUDED

Maximum Lifting Height:
39 1/2"
(w/ extension pad)

6,000 lb. Capacity

COMMERCIAL GRADE

Call Us For Current Pricing And SPECIALS!



EM-06

The Atlas EM06 full platform portable mid rise lift is a great choice for the tire shop or service center that wants to get a passenger car or light SUV into the air as quickly as possible. Most full platform portable lifts only lift the vehicle about 24 inches. The Atlas EM06 raises the vehicle a full 40 inches (with lift blocks); a very comfortable working height for the technician.

IN STORE PICK-UP PRICE
\$1495
OR
\$1745
W/ SHIPPING INCLUDED

6,000 lb. Capacity

FEATURES

- 6,000 lb. lifting capacity
- Portable
- Minimum Height: 4 1/2"
- Maximum Height (With Blocks): 40"
- Three locking positions at heights of: (w/o rubber blocks) 13 3/4", 27 3/4", and 36"
- 110V Power Unit

Maximum Lifting Height:
40"
(w/ positioning blocks)



110V

COMMERCIAL GRADE

WATCH OUR VIDEO ONLINE!

Optional Support Bar Set



ATTD-SUPPORTBARKIT
IN STORE PICK-UP PRICE
\$350
OR
\$500
W/ SHIPPING INCLUDED

Visit Our Website FOR MORE Product Photos AND DETAILED SPECIFICATIONS



TD-6MR

The Atlas TD6MR is a free standing 6,000 lb. capacity portable scissor lift. The Atlas TD6MR is the perfect lift for body shops and wheel service specialists that need extra lifting height. This portable lift easily raises a 6,000 LB. car or truck to a comfortable working height.

IN STORE PICK-UP PRICE
\$1495
OR
\$1745
W/ SHIPPING INCLUDED

6,000 lb. Capacity

Visit Our Website FOR MORE Product Photos AND DETAILED SPECIFICATIONS

FEATURES

- 6,000 LB. Capacity
- Portable, Easy To Move
- Powder Coated
- Separate Power Unit Stand Included
- Several Locking Positions
- Dual Hydraulic Cylinders
- Truck Adapters Included
- Commercial Grade
- Single Point Lock Release

Maximum Lifting Height:
53 1/2"
(w/ truck adapters)



COMMERCIAL GRADE



Kwik Bay

The Atlas Kwik Bay is a free standing 7,000 lb. capacity portable scissor lift. The Atlas Kwik Bay is the perfect lift for body shops and wheel service specialists that need extra lifting height. This portable lift easily raises a 7,000 LB. car or truck to a comfortable working height and does not require the customer to position arms under the lifting points of the car.

FEATURES

- 7,000 LB. Capacity
- Portable
- Open center
- 110V motor
- Air operated locks
- Zerk grease fittings at hinge points
- Open middle for easy access
- Four positioning blocks

IN STORE PICK-UP PRICE
\$2295
OR
\$2545
W/ SHIPPING INCLUDED

Maximum Lifting Height:
41"
(w/ positioning blocks)

COMMERCIAL GRADE

PRICES SUBJECT TO CHANGE
VISIT OUR WEBSITE FOR CURRENT PRICING AND SPECIALS



7,000 lb. Capacity

SPECIALTY LIFTS + COMBOS

WE ARE NOT RESPONSIBLE FOR MISPRINTS. PRICES AND SPECIFICATIONS ARE SUBJECT TO CHANGE.



FM9SL

The Atlas 9KFMSL flush mounted scissor lift has a rated capacity of 9,000 LB. and a total lifting height of just over 71 inches.

IN STORE PICK-UP PRICE
\$3295
 OR
\$3545
 W/ SHIPPING INCLUDED

Flush Mount Scissor Lift



FEATURES

- 9,000 lb. capacity
- 71 1/2" maximum lifting height
- Extendable platforms
- Air actuated locks
- Open middle for easy access
- Separate Self-Contained Control Panel
- Mechanical safety locks
- Shipping Weight: 2,500 lbs.



SLP-9K

COMMERCIAL GRADE

The Atlas SLP-9K full rise scissor lifts combine an extremely low lift platform height and a full rise scissor jack system. The Atlas SLP-9K full-rise scissor lifts can be flush mounted. It is the perfect above ground lift for those customers with ceiling height restrictions, or those service shops that want to avoid the cluttered look of dozens of vertical lift columns.

FEATURES

- 9,000 LB. capacity
- Open center for easy access
- 220 volt, full rise
- Powder coat finish
- Commercial grade
- Air operated locks
- Positioning blocks included

IN STORE PICK-UP PRICE
\$4295
 OR
\$4545
 W/ SHIPPING INCLUDED

WATCH OUR VIDEO ONLINE!

CAN BE FLUSH MOUNTED

Maximum Lifting Height: 78"
 (w/ positioning blocks)



Rotisserie

This auto body rotisserie is great for anyone wanting to restore a car or truck body or frame. The rotisserie allows a full 360° of vehicle movement by just turning the crank. When the vehicle is properly mounted and positioned, the rotisserie SPINS and allows the operator to have easy access to all parts of the body for welding, sandblasting, or any other work that needs to be done.

Hand Crank



Poly-Coated Steel Casters



Threaded Rod Adjusters



IN STORE PICK-UP PRICE
\$1095
 OR
\$1245
 W/ SHIPPING INCLUDED



WATCH OUR VIDEO ONLINE!

Atlas Lawn Mower Adapter

The ATLAS LMA (lawn mower adapter) will transform most two post above ground lifts with symmetric arms into an easy to use lawn mower lift, golf car lift, snowmobile lift, ATV lift, or a small sports car lift. The LMA is adjustable in width to accommodate the many different arm configurations found on two post lifts. The ATLAS LMA can be used in an infinite amount of wheel base configurations to allow the operator great flexibility in lifting different pieces of lawn service equipment with varying wheelbases.

Specifications

Capacity	5,000 LB. ‡
Adjusts In Width	7' 4 1/4" - 10' 2 1/2"
Wheel Well Width	12"
Steel Thickness	1/4" (12 gauge)
Shipping Weight	600 LBS.

‡ Depending on capacity of lift, and adapter distance from lift columns.

Transform Your 2-Post Lift Into A 4-Post Lift

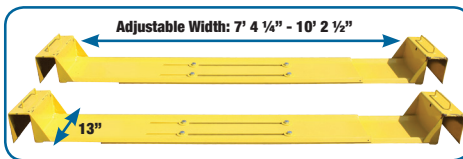

IN STORE PICK-UP PRICE
\$995
 OR
\$1195
 W/ SHIPPING INCLUDED



*Lift Not Included



*Lift Not Included

Alignment Lift + Instrumentation Combos

Atlas 412A + Two RJ-6000 Rolling Jacks + 501 Alignment Machine + 4 Point Clamps

COMMERCIAL GRADE

A Huge Savings When Bought Together



SAVE HUNDREDS \$\$\$

Visit Our Website Or Call Us For Your Best Deal

More Combo Deals Online!

Atlas 414A + Two RJ-7000 Rolling Jacks + 601 Pro Alignment Machine + 3 Point Clamps

A Huge Savings When Bought Together



Air / Hydraulic Rolling Jacks

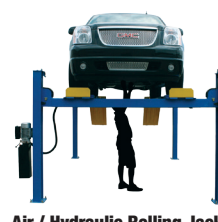

Air / Hydraulic Rolling Jacks



Mobile Column Lift Systems

Don't waste valuable floor space with a large four post lift. Atlas Mobile Column Lift Systems will save shop space and money versus a four post lift. No need to buy an extended length 4-post lift. With Atlas mobile column lifts, longer wheel bases are not a problem. Adjustable forks accommodate a wide range of wheel sizes. All Atlas Mobile Column Lift Systems electronically ensure synchronization of all columns.

44,000 lb
CAPACITY SYSTEM

IN STORE PICK-UP PRICE
\$19995
Per Set Of 4 Columns

WATCH OUR
VIDEO
ONLINE



1-Phase

**Battery
Powered**

66,000 lb
CAPACITY SYSTEM

IN STORE PICK-UP PRICE
\$25995
Per Set Of 4 Columns



Built-in hydraulic pallet jack system allows columns to be moved easily on level concrete surface with a minimum thickness of six (6) inches.



FEATURES

- Automatic Safety Stops
- Simultaneous operation of all columns
- Electronically ensures synchronization of all columns
- Can be "Expanded" from a four (4) column system to a six (6) or eight (8) column system

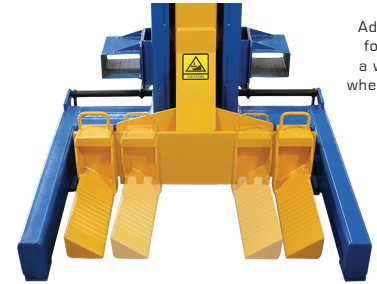

Adjustable arm forks support a wide array of wheel assemblies.

74,000 lb
CAPACITY SYSTEM

IN STORE PICK-UP PRICE
\$27995
Per Set Of 4 Columns



Battery Powered

**Battery
Powered**

111,000 lb
CAPACITY SYSTEM

IN STORE PICK-UP PRICE
\$42500
Per Set Of 6 Columns



MOBILE COLUMN LIFT SYSTEM ACCESSORIES

12,000 lb
Capacity
Tripod
Stands

IN STORE PICK-UP PRICE
\$1395
Set Of 4



16,500 lb
Capacity
Tripod
Stands

IN STORE PICK-UP PRICE
\$1795
Set Of 4



MOTORCYCLE LIFTS

WE ARE NOT RESPONSIBLE FOR MISPRINTS.
PRICES AND SPECIFICATIONS ARE SUBJECT TO CHANGE.

Atlas Cycle Lift

IN STORE PICK-UP PRICE
\$749
OR
\$899
W/ SHIPPING INCLUDED

The Atlas Cycle Lift is one of the industry's longest motorcycle lifts. The motorcycle lift has platform length of 93 inches. In addition to the heavy gauge diamond plated 93 inch platform, the Atlas Cycle Lift has an additional 20 inch removable approach ramp.



Includes **FREE** Removable Rear Section To Make Wheel Service Easy

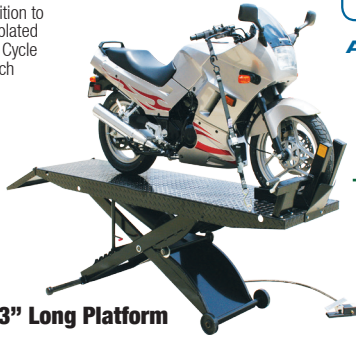

93" Long Platform



ATLAS CYCLE LIFT XLT

IN STORE PICK-UP PRICE
\$949
OR
\$1099
W/ SHIPPING INCLUDED

Extra Wide 48" Center Table

Motocross Lift

The Motocross Lift HT1007 is a lightweight, portable lift. This lift is ideal for anyone looking for an inexpensive way to get their bike off the floor. The lightweight and compact design also allows you to take this lift with you on the road.

IN STORE PICK-UP PRICE
\$110
OR
\$260
W/ SHIPPING INCLUDED

Lightweight And Portable



Multiple Colors Available



Atlas XLT Kit

The Atlas XLT kit will fit the Atlas Cycle Lift. The Atlas XLT kit includes two 12" side extensions, a two wheeled dolly, approach ramp extensions, three connector rods and clips. In less than two minutes, you can convert a standard motorcycle lift into an ATV lift.

IN STORE PICK-UP PRICE
\$225
OR
\$375
W/ SHIPPING INCLUDED

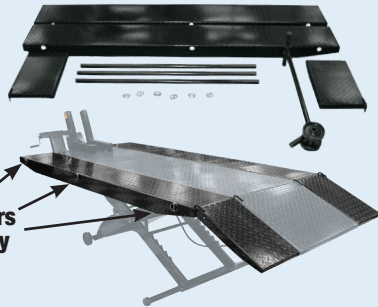

Three Support Bars For Extra Stability

Fits Atlas Cycle Lifts

- [2] 12" Side Extensions
- [2] Approach ramp extensions
- One two wheeled dolly (used for moving the lift)
- Three rods (used to connect/support the side extensions)
- Set of pins (used to secure the rods in place)

Motorcycle Jack

The Atlas Motorcycle Jack is a lightweight scissor jack that fits nicely under most motorcycle and ATV frames.

IN STORE PICK-UP PRICE
\$89
OR
\$134
W/ SHIPPING INCLUDED

Two Models Available



Atlas HT-ACL Cycle Lift

The Atlas HT-ACL Cycle Lift features a removable (drop in) roller plate with grooved rollers for better traction. The motorcycle lift has a platform length of over 85 inches.



- Includes:
- Motorcycle Vise
 - Approach Ramp
 - Removable Drop-In Roller Plate

85 1/2" Long Platform

HT-ACL
IN STORE PICK-UP PRICE
\$749
OR
\$899
W/ SHIPPING INCLUDED
85 1/2" Table Length

HT-ACL XLT
IN STORE PICK-UP PRICE
\$949
OR
\$1099
W/ SHIPPING INCLUDED
Extra Wide 48" Center Table

Atlas EML-1200 Motorcycle Lift

The Atlas EML-1200 is an electric/hydraulic 1200 lb. capacity motorcycle lift with an extremely smooth ascent and a platform length of over 88 inches.

ELECTRIC / HYDRAULIC
IN STORE PICK-UP PRICE
\$1195
OR
\$1345
W/ SHIPPING INCLUDED

WATCH OUR VIDEO ONLINE!



Specifications	
Weight Capacity	1,200 LB.
Length (w/ ramp)	104" (8' 8")
Center table width (without side extensions)	29 1/2" (2' 5 1/2")
Center table width (with side extensions)	48"
Fully Lowered	6"

EML-1200 XLT

IN STORE PICK-UP PRICE
\$1395
OR
\$1545
W/ SHIPPING INCLUDED
48" Center Table



Extra Wide

Atlas Hi-Rise 1500 Motorcycle / ATV Lift

The Atlas HI-RISE 1500 is one of our most popular motorcycle and ATV lifts.

IN STORE PICK-UP PRICE
\$1295
OR
\$1445
W/ SHIPPING INCLUDED

FEATURES

- Weight capacity: 1,500 LB.
- Powder coat finish
- Includes removable drop out section
- Includes chopper extension
- Includes side extensions
- Table length with chopper extension: 99"
- Removable approach ramp included
- 6 Locking Positions
- Diamond Plate
- Vise included



- Includes:
- Side Extensions
 - Chopper Extension
 - Motorcycle Vise
 - Approach Ramp
 - Removable Drop Out Section

Specifications	
Overall Length (w/ Ramps)†	125" (10' 5")
Center Table Length (w/o Ramps)†	99 3/4" (8' 3 3/4")
Side Extension Length (w/o ramps)	88 1/2" (7' 4 1/2")
Center Table Width (w/ Side Extensions)	51" (4' 3")
Center Table Width (w/o Side Extensions)	29 1/2"
Height Fully Raised	43" (3' 7")
Height Lowered	7 1/2"
Shipping Weight	800 LB.

† These measurements are taken with the FREE chopper extension attached (20 3/4" long)

Atlas Edge 501

The Atlas Edge 501 is an ultra fast and accurate alignment system for under \$10,000. The Atlas® 501 is the perfect choice for quick reliable "dead-nut" alignment "full body" accuracy for an entry level price. The 501 System utilizes eight cameras (these cameras "look at each other" from both sides of the rear of the vehicle) to provide accurate measurements between rear wheels just as the two front cameras provide measurements between the front wheels. The eight camera system completes a rectangle which produces a closed 360 degree measured field.



FEATURES

- Bluetooth® Wireless Data Transmission
- 8 Camera Optical System
- Standard Four Point Clamps Included
- Deluxe Cabinetry With Printer Drawer
- Lightweight (8 LB.) Sensor Heads
- Printer, LCD Monitor, Keyboard
- Lipless Wheel Adapters
- 2 Heavy Duty Turntables Included
- 1 Brake Pedal Depressor
- 1 Steering Wheel Lock
- Wireless App Compatible
- Vast Vehicle Database
- Simple 4 Key Operation
- Spoiler Program For Low Air Dams

Servicing or updating your Atlas Edge alignment machine is simple if you have internet access at your shop!

We can access your alignment computer to provide upgraded software, install new vehicle data and diagnose software or hardware issues. There is no need to wait for the "alignment service tech in the little white van". We stock parts and can ship quickly. If you can replace parts on a car, then you can replace any broken part on your Atlas Edge alignment machine.



- Only four color coded (arrow) buttons are required to operate the entire program.
- The system can be operated from any sensor head and the software is simple.
- Lightweight (8 lb.) sensor heads.

**ALIGNMENT
Training Classes
AVAILABLE
Visit Our Website
FOR DETAILS!**

501 W/ Traditional 4-Point Clamp System

Includes a set of self-centering 4 point clamps, with removable claws. These clamps will clamp wheels 10"-24" and require runout compensation.

IN STORE PICK-UP PRICE
\$9995
OR
\$10145
W/ SHIPPING INCLUDED

Set Of 4



SAVE BIG \$\$\$ When You Buy An Alignment Lift And An Alignment Machine Combo

501 W/ Fast Clamp System

Clamping method prevents damage to expensive rims

The 3 point "Fast Clamp System" offers the finest wheel reference points in the industry. The operator does NOT need to perform any lateral runout compensation procedures or "roll-back" maneuvers when the sensors are mounted to the patented "Fast Clamp System". The technician does not need to disturb the vehicle's natural running position by rolling or raising it. A vehicle is most accurately aligned when it is in the "full rest" position.

IN STORE PICK-UP PRICE
\$11995
OR
\$12145
W/ SHIPPING INCLUDED

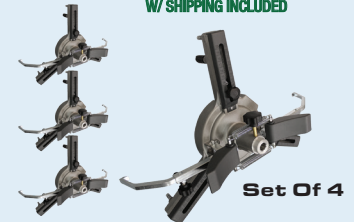

Atlas Edge 601 Pro

The Atlas Edge 601 alignment system may be the most user friendly wheel alignment system available. The Atlas Edge 601 combines low price, simple to use technology, and repeatable accuracy in a machine that is "ready to use" out of the box.

FEATURES

- The system can be operated from any sensor head. Software is simple.
- The machine is "ready to go" out of the box.
- Bluetooth technology eliminates the need for any connecting cables
- Deluxe cabinetry
- Fast set up and unparalleled accuracy in an alignment system costing thousands of dollars less than the Big Name competition ensures a fast return on your investment.
- Non-proprietary computer hardware makes replacement or upgrades affordable.
- Printer, LCD monitor, and keyboard

Servicing or updating your Atlas Edge alignment machine is simple if you have internet access at your shop!

We can access your alignment computer to provide upgraded software, install new vehicle data and diagnose software or hardware issues. There is no need to wait for the "alignment service tech in the little white van". We stock parts and can ship quickly. If you can replace parts on a car, then you can replace any broken part on your Atlas Edge alignment machine.

W/ Fast Clamps

Clamping method prevents damage to expensive rims

IN STORE PICK-UP PRICE
\$13995
OR
\$14145
W/ SHIPPING INCLUDED



WATCH OUR VIDEO ONLINE!

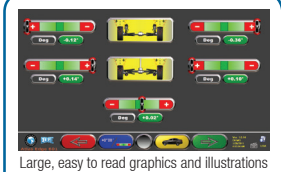

Huge Vehicle data base with yearly (2) updates available.



**ALIGNMENT
Training Classes
AVAILABLE**

Atlas Edge 801

We have the most innovative large truck alignment system on the world market. It features Bluetooth wireless data transmission and is customized for all truck axle configurations – 2, 3, 4 and 5 axle configurations. This system combines blazing speed, precision accuracy, and reliable Bluetooth® wireless communication all at a very affordable cost. It is PC Driven using high quality PC components and managed by Windows XP Pro®. The system prints detailed alignment reports and stores these reports on its hard drive for future retrieval.

FEATURES

- Bluetooth wireless data transfer
- Software lets you choose between trucks, trailers, buses, coaches, light trucks and more.
- Allows you to choose between 2, 3, 4, or 5 axle vehicles
- Specifications for thousands of trucks, C, coaches, and light trucks are included in software.
- Measures collision angles such as axle set back and offset to help diagnose uncommon problems.
- Optional calibration package
- Kingpin fixture assembly and electronic focal points allow operator to quickly align trailer axles using the trailer kingpin as reference



- Non Runout Fast Clamps- Accurately references the center of the wheel
- Eliminates need for time consuming runout compensation of all 6 wheel positions of a 3 axle tractor

IN STORE PICK-UP PRICE
\$27995
 OR
\$28245
W/ SHIPPING INCLUDED



- TOTAL WHEEL ALIGNMENT- Performs a total alignment of the vehicle and looks at all axles as a whole and not just a single axle at a time.
- Alignments can be performed in a service bay or outside parking area



- Spoiler program for low air dams
- Turning angle gauges



ALIGNMENT Training Classes AVAILABLE Visit Our Website FOR DETAILS!



- Only four color coded buttons operate the entire system.
- Program walks the operator thru the alignment process in a simple step by step manner.

Atlas Cyclops

With IC3D TowerFree™ Technology

After almost 20 years, a revolutionary new 3-D system is now available. Introducing the Atlas® Cyclops 3-D TowerFree™ Camera alignment system featuring IC3D technology. The Atlas® 3-D camera system does not require a fixed tower and is easily installed on the alignment lift runways so the size of the bay space needed is determined by the length of the lift (or vehicle on the lift). No more loss of valuable bay space at the front of your alignment lift. The "alignment lift" may be a four post lift, a scissor lift, a parallelogram lift, or "the floor".

IN STORE PICK-UP PRICE
\$19995

FEATURES

- Compatible with any alignment lift
- Works flawlessly at any height
- Save valuable bay space
- Wireless communication eliminates the need to walk to the console
- Portable computer console
- Free InstaCheck system
- 3-Point Non-Runout FastClamps



The InstaCheck system provides accurate alignment measurements (on the floor) in less than 80 seconds. Simple to use and a great way to provide alignment information to potential alignment customers. Sell more alignments!



- Compensates for an unlevel lift



- 3-Point Non-Runout FastClamps

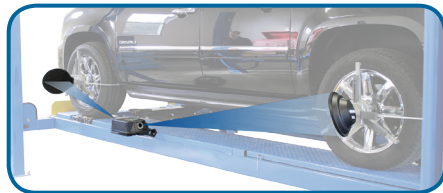

- The cameras work at any height
- Patented three (3) dimensional sensor targets eliminate the need for rollback

CYCLOPS ALSO DOUBLES AS AN INSTACHECK SYSTEM



Visit Our Website FOR MORE Product Photos AND DETAILED SPECIFICATIONS

WATCH OUR VIDEO ONLINE!

Atlas Wheel Stands And Turntable Package

The Atlas Wheel Stands are the perfect choice for those smaller shops who want the advantages of a four post lift but have only limited floor space. The set of Atlas Wheels Stands can support up to 6,000 lbs. and, because they are taller than most other stands, are the perfect height for hanging wheel alignment sensors.

Wheel Stand Package

IN STORE PICK-UP PRICE
\$1895
 OR
\$2045
W/ SHIPPING INCLUDED

Includes 4 Turntables

Visit Our Website FOR MORE Product Photos AND DETAILED SPECIFICATIONS

- Includes 4 Steel Wheel Stands
- 4 Alignment Turntables
- 39 1/2" High
- .38" Thick Top Steel Plating
- 19.5" x 19.5" Solid Steel Surface
- 6,000 LB Capacity (1,500 LB Per Stand)



Color May Vary



Atlas Traditional 4-Point Clamps

Four Point 10"-24"
Self-Centering 4 Point Clamps
(Set Of 4)

Traditional self-centering 4 point clamps with removable claws. These clamps will clamp wheels 10"-24" and require runout compensation.



IN STORE PICK-UP PRICE
\$1300
OR
\$1340
W/ SHIPPING INCLUDED

Set Of 4

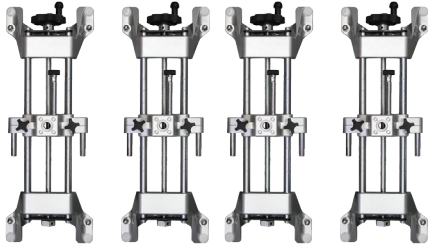

Atlas 3-Point Fast Clamps

Three Point 13"-24" Non-Runout Wheel Clamps (Set Of 4)

The 3 point "Fast Clamp System" offers the finest wheel reference points in the industry. The operator does NOT need to perform any lateral runout compensation procedures or "roll-back" maneuvers when the sensors are mounted to the patented "Fast Clamp System".



IN STORE PICK-UP PRICE
\$2995
OR
\$3045
W/ SHIPPING INCLUDED

Set Of 4



AK-1 Alignment Kit

Converts a 4 post lift into an alignment lift.

IN STORE PICK-UP PRICE
\$1395

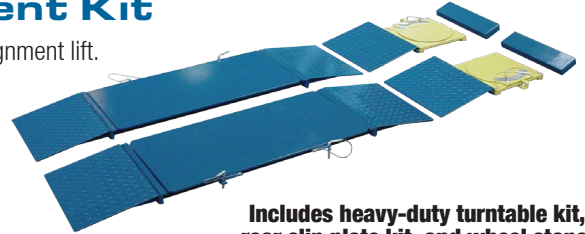

Includes heavy-duty turntable kit, rear slip plate kit, and wheel stops.

Atlas Alignment Training Course



Visit Our Website For Details

Turntables

(Pair) Passenger Light Truck

IN STORE PICK-UP PRICE
\$345
OR
\$445
W/ SHIPPING INCLUDED

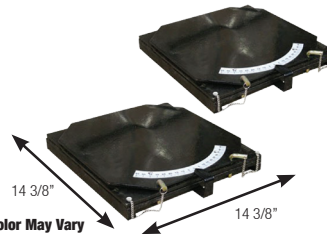

*Color May Vary

Atlas Alignment Calibration Bar

The Atlas calibration fixture system allows the owner of an Atlas Edge 401 or Atlas Edge 601 computer alignment machine to perform sensor calibration procedures in his shop.

(For Edge 401, 501, and 601)

IN STORE PICK-UP PRICE
\$699
OR
\$714
W/ SHIPPING INCLUDED



Transmission Teardown Workbench

IN STORE PICK-UP PRICE

\$495

OR
\$645

W/ SHIPPING INCLUDED

HTTB



Sloping top with drain



Visit Our Website FOR MORE Product Photos AND DETAILED SPECIFICATIONS

FEATURES

- 47" Wide x 32" Deep x 41" High
- Heavy Duty Steel Construction
- Lockable Casters
- Lockable Drawer
- Shipping Weight: 200 lb.

2 Drawer Workbench HEAVY DUTY STEEL

IN STORE PICK-UP PRICE

\$225

OR
\$375

W/ SHIPPING INCLUDED

FEATURES

- L x W x H: 59" x 25" x 34"
- Heavy Duty Steel Construction
- Shipping Weight: 180 lb.

HTWS911



LOCKING DRAWERS

3 Drawer Workbench HEAVY DUTY STEEL

IN STORE PICK-UP PRICE

\$325

OR
\$475

W/ SHIPPING INCLUDED

FEATURES

- L x W x H: 79" x 25" x 34"
- Heavy Duty Steel Construction
- Shipping Weight: 210 lb.

HTWS79111



LOCKING DRAWERS

Wood Top Workbench

IN STORE PICK-UP PRICE

RED **\$99**



HTTZL2060W-RD

Wood Top Workbench

IN STORE PICK-UP PRICE

GRAY **\$99**



HTTZL2060W-GR

5 Drawer With Wood Top

IN STORE PICK-UP PRICE

\$340



HTTSA5405-X

Rolling Cabinet

IN STORE PICK-UP PRICE

\$165



HTTC321A

Rolling Work Table

IN STORE PICK-UP PRICE

\$95



HTTC304C

WHEEL BALANCERS

WE ARE NOT RESPONSIBLE FOR MISPRINTS.
PRICES AND SPECIFICATIONS ARE SUBJECT TO CHANGE.

WB-HS

The Atlas WB-HS is the perfect choice for smaller service shops or mobile wheel service companies. The Atlas WB-HS (with built in wheel assembly) is extremely portable and can easily be moved from service bay to service bay or can be rolled up a ramp to the inside of a mobile service truck.



IN STORE PICK-UP PRICE
\$995
OR
\$1145
W/ SHIPPING INCLUDED

FEATURES

- Extremely portable
- Operates on both 110V and 12V-24V DC power
- Easily connects to a car battery
- Static and dynamic balancing modes
- 1-year limited warranty



Built In Wheel Assembly

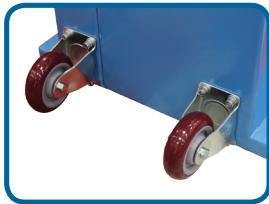

Foot Brake Pedal

Holds wheel in place when mounting wheel weights

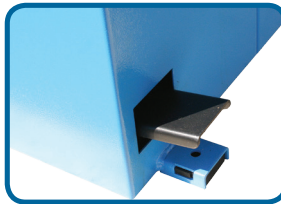

Specifications

Max Tire Diameter	39"
Rim Diameter	10"-32"
Rim Width	1 1/2"-20"
Max. Wheel Weight	130 lb.
Shipping Weight	225 lb.

WB11

The Atlas WB 11 is the most popular Atlas wheel balancer that we sell. Low price, dependability and repeatable accuracy make the Atlas WB-11 the backbone of the entire Atlas line of computer wheel balancers.



IN STORE PICK-UP PRICE
\$1195
OR
\$1345
W/ SHIPPING INCLUDED

FEATURES

- Automatic and pedal operated brake
- Automatic start/stop when hood is lowered/raised
- Static and dynamic balancing modes
- Self-diagnosis / Self-calibration
- 1-year limited warranty

Specifications

Max Tire Diameter	39"
Rim Diameter	10"-32"
Rim Width	1 1/2"-20"
Max. Wheel Weight	150 lb.
Shipping Weight	355 lb.

Static Bubble Balancer

IN STORE PICK-UP PRICE
\$59

- Rugged die-cast aluminum head cone
- Easy to use self-leveling stand. No need for leveling legs
- Shipping Weight: 21 LB



WB41

The Atlas WB 41 is the larger version of our extremely popular Atlas WB-11.



IN STORE PICK-UP PRICE
\$1395
OR
\$1545
W/ SHIPPING INCLUDED

FEATURES

- Automatic and pedal operated brake.
- Automatic start/stop when hood is lowered/raised.
- Static and dynamic balancing modes.
- Self-diagnosis / Self-calibration
- 1-year limited warranty

Specifications

Max Tire Diameter	39"
Rim Diameter	10"-32"
Rim Width	1 1/2"-20"
Max Wheel Weight	165 lb.
Shipping Weight	380 lb.



Buy A Tire Changer When You Buy A Balancer And **SAVE HUNDREDS \$\$\$**
Visit Our Website Or Call Us For Your Best Deal

WB49

The Atlas WB 49 computer wheel balancer incorporates all the great features (AND MORE) of the Atlas WB41 computer wheel balancer.



IN STORE PICK-UP PRICE
\$1695
OR
\$1845
W/ SHIPPING INCLUDED

FEATURES

- Automatic data entry
- Weight Splitting feature
- Automatic and pedal operated brake
- Automatic start/stop when hood is lowered/raised
- Static and dynamic balancing modes
- Rapid optimization (OPT)
- Self-diagnosis / Self-calibration
- 1-year limited warranty

AUTOMATIC DATA ENTRY



Specifications

Max Tire Diameter	39"
Rim Diameter	10"-32"
Rim Width	1 1/2"-20"
Max Wheel Weight	150 lb.
Shipping Weight	380 lb.



WB55

The Atlas 3-D WB-55 has a 19 inch LED LCD digital flat screen that displays high resolution tire and wheel images, providing a clear "picture" of tire/wheel assembly and out of balance condition. The Atlas WB-55 incorporates the **Insta/Input (I/I)** measuring system that automatically enters all three parameters (rim size, rim width, and distance of rim from machine) when the operator touches the inside and outside of the mounted rim with the built-in measuring rods. The Atlas **Smart/Selector (S/S)** allows the operator to turn one knob and select the desired balancing mode.

Insta/Input Automatic Data Entry



Standard Accessories



LCD Monitor



IN STORE PICK-UP PRICE
\$2195
OR
\$2345
W/ SHIPPING INCLUDED

Specifications	
Max Tire Diameter	39"
Rim Diameter	10"-32"
Rim Width	1 1/2"-20"
Max Wheel Weight	165 lb.
Shipping Weight	400 lb.

FEATURES

- 19" Color LED LCD Monitor
- Large weight tray
- Automatic positioning where to apply weights
- Automatic and pedal operated brake
- Automatic start/stop when hood is lowered/raised
- Static and dynamic balancing modes
- Rapid optimization (OPT)
- Self-diagnosis
- Self-calibration
- Exceptional stability in reading the unbalance between planes
- Display in grams or ounces, in mm or inches
- Very fast 7 second cycle time
- Multi user function for up to 4 different users
- Seven (7) ALU settings for both adhesive and clip on weight
- 1-year limited warranty

*Requires manual input of some data between 23" - 32"



WB77

The Atlas WB-77 is our absolute top of the line wheel balancer. Please watch our online video highlighting all the amazing features of this balancer. The Atlas WB-77 guarantees dead nut accuracy by eliminating the "human error" of rim measurement and weight placement.

FEATURES

- 17" Color LED LCD Monitor
- Large weight tray
- Self-calibration
- Auto/ALU + S-Drive + Direct3D
- Automatic distance, diameter and width entry
- Automatic ALU-type entry [Auto/ALU technology]
- Precise direct measuring of ALU-rims weight planes [Direct 3D technology]
- Tire positioning optimization
- Speech synthesizer
- 110 volt [Power Guard technology] with surge protection
- Automatic pivoting to the weight placing location [S-Drive technology]
- Precise placement of adhesive weights with the clip on the gauge arm
- SPLIT - behind the spoke weight placement [invisible weight]
- Static imbalance minimizing
- Zero point setting
- High-precision spindle, shaft diameter 40 mm



IN STORE PICK-UP PRICE
\$3995
OR
\$4145
W/ SHIPPING INCLUDED

Specifications	
Max Tire Diameter	35 1/2"
Rim Diameter	10"-28"
Rim Width	1 1/2" - 20"
Max Wheel Weight	155 lb.
Shipping Weight	420 lb.



WBT-210 From Car Wheels To Semi Wheels

The Atlas WBT-210 truck tire wheel balancer is one of the best values in large truck tire computer balancers sold. This truck tire balancer is priced thousands of dollars less than the Big Name brand truck tire balancers and offers the same accuracy and reliability as the rest of the Atlas wheel balancer products.

Visit Our Website
FOR MORE
Product Photos
AND DETAILED SPECIFICATIONS

Specifications	
Max Tire Diameter	47"
Rim Diameter	10"-32"
Rim Width	1 1/2"-20"
Balance Capacity	440 lb.
Shipping Weight	725 lb.

Standard Accessories

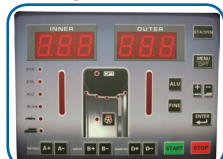

IN STORE PICK-UP PRICE
\$3495
OR
\$3745
W/ SHIPPING INCLUDED

Atlas Universal Truck Adapter

IN STORE PICK-UP PRICE
\$499
OR
\$549
W/ SHIPPING INCLUDED

The Atlas Universal Adapter (TRUCK)/PF-40000 is designed for truck wheels that have either a closed center or wheels that are made "without a true center" and classified as lug-centric.



FEATURES

- Cone sets for car and light truck tires
- Cone and spacer set for truck, bus or implement wheels
- Quick release nuts
- Heavy duty steel wing nut
- Pneumatic wheel lift capacity: 300 lbs.
- Protective hood
- Self-diagnosis / Self-calibration
- Display in grams or ounces;
- 1-year limited warranty

Atlas "UA" Universal Adapter (40 mm Shafts)

Atlas Universal Adapter (UA) is designed for wheels that have either a closed center or wheels that are made "without a true center" and classified as lug-centric. The Atlas UA was specifically designed for those custom alloy wheels that require a special mounting procedure.

Need to use with most GMC® Trucks & SUVs

WATCH OUR VIDEO ONLINE!

IN STORE PICK-UP PRICE
\$399
OR
\$414
W/ SHIPPING INCLUDED



ATWB-UA

Truck Adapter Set (40 mm Shafts)

This two piece truck adapter set consists of a double sided center cone for wheel centers up to 6 inches in diameter. A spacer is also included to help prevent offset wheels from contacting the side of the balancer. Fits 40mm shafts.

IN STORE PICK-UP PRICE
\$199
OR
\$219
W/ SHIPPING INCLUDED

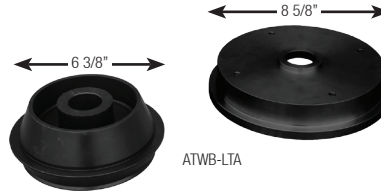

For Large Center Hole Rims on 1 Ton Trucks



WBAWL Pneumatic Wheel Lift

The WBAWL is a pneumatic wheel lift designed to raise and support (up to 150 lb.) tire/wheel combinations. The WBAWL's compact design allows it to fit under most wheel balancers.

IN STORE PICK-UP PRICE
\$299
OR
\$449
W/ SHIPPING INCLUDED

Visit Our Website FOR MORE Product Photos AND DETAILED SPECIFICATIONS



ATTC-WBAWL

Specifications

Capacity	150 lbs
Max. Lifting Height	20 1/2"
Min. Lifting Height	8"
Overall Height	32 1/2"
Required Air Pressure	100 psi
Shipping Weight	100 lbs

Atlas Quick Release Nut

The Atlas Quick Release Nut fits all Atlas brand wheel balancers. Available in both 40mm and 36mm sizes. Please specify your shaft size.

IN STORE PICK-UP PRICE
\$80
OR
\$95
W/ SHIPPING INCLUDED

Available in 36mm OR 40mm



Fast Mounting

ATWB-NUT

Atlas Metal Wing Nut

For Use with Heavy Truck Wheels

IN STORE PICK-UP PRICE
\$99
OR
\$114
W/ SHIPPING INCLUDED

Available in 36mm OR 40mm



ATWB-MWN

Atlas Passenger Wheel Balancers Can Be Converted Into Motorcycle Wheel Balancers

MC Kit

The Atlas MC adapter kit will allow your Atlas (passenger and light truck) computer wheel balancer to balance a variety of motorcycle wheels with hub assemblies up to 9.25 inches wide. The Atlas MC kit has a 14mm shaft size.

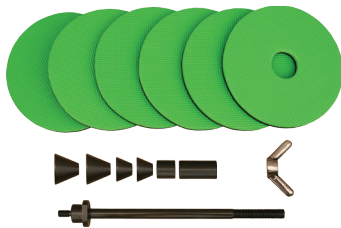

IN STORE PICK-UP PRICE
\$300
OR
\$315
W/ SHIPPING INCLUDED

ATWB-MCKIT-NEW

MC-XLT Kit

The Atlas MC-XLT adapter kit will allow your Atlas (passenger and light truck) computer wheel balancer to balance a variety of motorcycle wheels with hub assemblies up to 13.75 inches wide. The Atlas MC XLT kit has a 19mm shaft size.

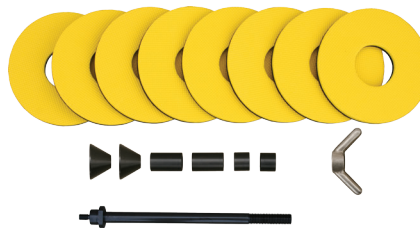

IN STORE PICK-UP PRICE
\$400
OR
\$415
W/ SHIPPING INCLUDED

ATWB-MCXLTKIT-NEW

Spoke Support Adapter

The Atlas SSA offers the needed support for those extra heavy tires and rear wheel assemblies found on many custom motorcycles. For use with all Atlas motorcycle wheel balancers.

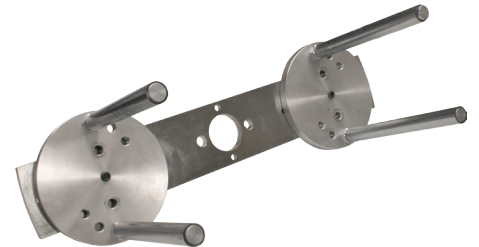

IN STORE PICK-UP PRICE
\$199
OR
\$214
W/ SHIPPING INCLUDED

ATWB-SSA



TTC-301

Heavy Duty Truck Tire Changer

1 Phase Motor

The Atlas TTC301 is a heavy duty truck tire changer designed to accommodate tire diameters in excess of 63". This Heavy Duty Atlas truck tire changer is designed and engineered to handle rim sizes from 3 3/8" to 27" and can easily accommodate tires with a maximum width of 30 1/2". The Atlas TTC301 truck tire changer is the perfect choice for the large truck tire center that specializes in mounting and demounting over the road semi tires.

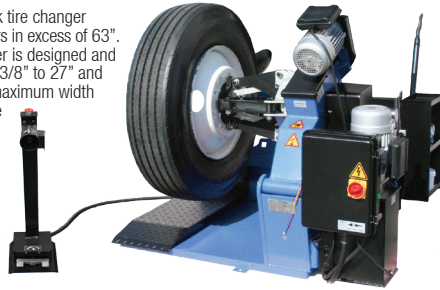

IN STORE PICK-UP PRICE
\$5495
OR
\$5745
W/ SHIPPING INCLUDED

Save Hundreds When You Buy A Combo!

COMBO DEALS ONLINE
www.GregSmithEquipment.com

TTC-301 Specifications

Center Hole Diameter	3-3/8" - 27"
Max. Wheel Weight	3,300 lb.
Max. Tire Diameter	63"
Max. Tire Width	30 1/2"
Shipping Weight	1,400 lb.

WATCH OUR VIDEO ONLINE!



TTC-305

Heavy Duty Truck Tire Changer

1 Phase Motor

This Heavy Duty Atlas truck tire changer is designed and engineered to handle rim bore sizes from 8 inches to 26 inches and tire diameters in excess of 55 inches. The fully automatic Atlas TTC-305 truck tire changer can easily accommodate tires with a maximum width of 30.5 inches. The TTC-305 truck tire changer features a single speed hydraulic chuck with five (5) locking rim positions. The ergonomic toggle control panel and foot pedals control the automatic operation of the truck tire changer.



IN STORE PICK-UP PRICE
\$6495
OR
\$6745
W/ SHIPPING INCLUDED

COMBO DEALS ONLINE
www.GregSmithEquipment.com

TTC-305 Specifications

Center Hole Diameter	3-3/8" - 27"
Max. Wheel Weight	838 lb.
Max. Tire Diameter	55"
Max. Tire Width	30 1/2"
Shipping Weight	1,490 lb.

FEATURES

- Handles rim bores from 8" to 26" and tire diameters in excess of over 55"
- Interchangeable Mount/Demount and Roller Heads
- Accommodates tires with a maximum width of up to 30.5 inches
- Electric/Hydraulic Self-Centering Four Jaw Chuck
- 5 different rim locking positions
- Aluminum Rim Accessories Included
- Automatic movement and positioning of bead tool, carriage, and chuck arm.
- 220 Volt/ 1 Phase Motor



TTC-303

Super Duty Truck Tire Changer

The Atlas TTC303 is a heavy duty truck tire changer designed and engineered to handle rim sizes from 4 1/4" to 56" and tire diameters in excess of over 90". The Atlas Truck Tire Changer can easily accommodate tires with a maximum width of up to 42". The TTC303 handles off-road tires, agricultural tires, super single tires, and skidder tires with ease.

IN STORE PICK-UP PRICE
\$7995
OR
\$8245
W/ SHIPPING INCLUDED

TTC-303 Specifications

Center Hole Diameter	4 1/4" - 46" (3' 10") [47" (3' 11") - 56" (4' 8") With Extensions]
Max. Wheel Weight	3,307 lb.
Max. Tire Diameter	90 1/2" (7' 6 1/2")
Max. Tire Width	42" (3' 6")
Shipping Weight	1,800 lb.

FEATURES

- Available With Either 1-Phase Or 3-Phase Power Unit
- Handles Rims From 4 1/4" To 56" And Tire Diameters In Excess Of Over 90"
- Changes Tires With A Maximum Width Of Up To 42 Inches
- 2 Speed (3 Phase Power Unit) Hydraulic Chuck
- 5 Rim Locking Positions
- 1 Speed Hydraulic Chuck When Equipped With 220 V, Single (1) Phase Power
- Portable Control Unit



Buy A Truck Tire Balancer When You Buy A Truck Tire Changer And **SAVE HUNDREDS \$\$\$**

1 Phase OR 3 Phase Motor



TTC-306

Automatic Super Duty Truck Tire Changer

3 Phase Motor

The Atlas TTC 306 features a remote controlled rotating bead breaker disc and mount/demount head that are controlled from either the portable remote console or (optional) ZigBee® remote control. This Super Duty Atlas truck tire changer is designed and engineered to handle rim sizes from 14" to 56" and tire diameters in excess of over 97".

IN STORE PICK-UP PRICE
\$9995
OR
\$10245
W/ SHIPPING INCLUDED



FEATURES

- Two Speed Hydraulic Chuck
- Portable Control Unit
- Remote controlled Tilting/Shifting Tool Arm
- Working Tool With Automatic Rotation System
- Wireless Control (Optional)



TTC-306 W/Wireless Control Unit

IN STORE PICK-UP PRICE
\$10395
OR
\$10645
W/ SHIPPING INCLUDED

TTC-306 Specifications

Center Hole Diameter	4 1/4" - 46" (3' 10") [47" (3' 11") - 56" (4' 8") With Extensions]
Max. Wheel Weight	3,968 lb.
Max. Tire Diameter	98" (8' 2")
Max. Tire Width	53" (4' 5")
Shipping Weight	2,260 lb.

TC211

The Atlas TC 211 wheel clamp tire changer is the perfect changer for a small commercial garage or an ATV/motorcycle dealer.

COMMERCIAL GRADE

IN STORE PICK-UP PRICE
\$995

**Bead Blaster
Not Included**

FEATURES

- 1-year limited warranty
- 4 plastic rim protectors
- Soap reservoir
- Automatic oiler
- Commercial grade
- Air operated jaw slides
- Steel, aluminum, alloy rims



Specifications

External clamping range	11" - 20"
Internal clamping range	12 1/2" - 12 1/2"
Maximum tire diameter	39"
Operating voltage	110V 1Ph
Maximum wheel width (Bead Breaker)	13"
Shipping weight	500 lb.

TC221

The Atlas TC221 is the perfect tire changer for a small commercial garage or an ATV/motorcycle dealer. It is designed to change tires on both high priced alloy wheels and steel wheels.

IN STORE PICK-UP PRICE
\$1095
OR
\$1245
W/ SHIPPING INCLUDED

**Bead Blaster
Not Included**

COMMERCIAL GRADE

FEATURES

- 1-year limited warranty
- 4 plastic rim protectors
- Soap reservoir
- Oiler, filter, regulator
- Commercial grade
- Air operated jaw slides
- Steel, aluminum, alloy rims



Specifications

External clamping range	9 3/4" - 23 1/4"
Internal clamping range	11 5/8" - 25 1/4"
Maximum tire diameter	39"
Operating voltage	110V 1Ph
Maximum wheel width (Bead Breaker)	13"
Shipping weight	500 lb.

TC229

COMMERCIAL GRADE

The Atlas TC229 has the same clamping and tire changing capabilities as the Atlas TC221 wheel clamp tire changer, but has the added, built-in bead blaster system to help inflate stiff sidewall tires or other "hard to inflate" tires.

IN STORE PICK-UP PRICE
\$1395
OR
\$1545
W/ SHIPPING INCLUDED

FEATURES

- 1-year limited warranty
- 4 plastic rim protectors
- Soap reservoir
- Oiler, filter, regulator
- Commercial grade
- Air operated jaw slides
- Steel, aluminum, alloy rims
- Bead blaster system



Specifications

External clamping range	9 3/4" - 23 1/4"
Internal clamping range	11 5/8" - 25 1/4"
Maximum tire diameter	39"
Operating voltage	110V 1Ph
Maximum wheel width (Bead Breaker)	13"
Shipping weight	500 lb.

TC289

The Atlas TC289 wheel clamp tire changer is the perfect wheel clamp tire changer for most general automotive service departments and medium sized tire stores. The powerful, adjustable bead breaker located on the side of the tire changer is designed to break even the most stubborn and rusted beads without damage to the rim. The Atlas TC289 is equipped with our powerful bead blast feature.



**Save Hundreds \$\$\$
When You Buy A
Tire Changer/Wheel Balancer
Combo**



IN STORE PICK-UP PRICE
\$1695
OR
\$1845
W/ SHIPPING INCLUDED

FEATURES

- 1-year limited warranty
- 4 plastic rim protectors
- Soap reservoir
- Oiler, filter, regulator
- Commercial grade
- Air operated jaw slides
- Steel, aluminum, alloy rims
- Bead Blaster System

COMMERCIAL GRADE

Specifications

External clamping range	11 7/8" - 28"
Internal clamping range	13 7/8" - 29 7/8"
Maximum tire diameter	47 1/2"
Operating voltage	110V 1Ph
Maximum wheel width (Bead Breaker)	18 1/2"
Shipping weight	650 lb.



TC755 Designed For Low Profile Tires

The Atlas TC755 wheel clamp tire changer is the perfect wheel clamp tire changer for most general automotive service departments and tire stores. The powerful bead breaker located on the side of the tire changer is designed to break even the most stubborn and rusted beads without damage to the rim. The Atlas TC755 is equipped with our powerful bead blast feature and has a tilt back column.



**Add An Assist
Arm Now Or In
The Future**

IN STORE PICK-UP PRICE
\$2095
OR
\$2245
W/ SHIPPING INCLUDED

Specifications

External clamping range	11 7/8" - 28"
Internal clamping range	13 7/8" - 29 7/8"
Maximum tire diameter	47 1/2"
Operating voltage	110V 1Ph
Maximum wheel width (Bead Breaker)	13 1/2"
Shipping Weight	650 lb.

FEATURES

- 1-year limited warranty
- 4 plastic rim protectors
- Soap reservoir
- Oiler, filter, regulator
- Tilt-back column
- Air operated jaw slides
- Bead Blaster System



TC229LH

The Atlas TC229LH wheel clamp tire changer is the Atlas TC229 wheel clamp tire changer that has been equipped with the pneumatic Atlas LH assist arm.

FEATURES

- Tire Inflator
- 3 Positions For Clamping Jaws
- 90-110 Psi
- Beadblaster
- Left Hand Assist Arm Assembly
- One Year "Parts Only" Limited Warranty

IN STORE PICK-UP PRICE
\$2095
OR
\$2245
W/ SHIPPING INCLUDED

**BEAD
BLASTER
SYSTEM**

Visit Our Website
**FOR MORE
Product Photos
AND DETAILED SPECIFICATIONS**

COMBO
DEALS
ONLINE
www.GregSmithEquipment.com



COMMERCIAL
GRADE

TC289DAA

The Atlas TC289 DAA wheel clamp tire changer is the Atlas 289 wheel clamp tire changer that has been equipped with the pneumatic Atlas LH assist arm plus the Atlas RF assist arm that includes a bead roller and second bead lifting/pressing disc.

FEATURES

- Tire Inflator
- Adjustable Bead Breaker
- 3 Positions For Clamping Jaws
- 90-110 Psi
- Beadblaster
- Left & Right Side Assist Arms
- One Year "Parts Only" Limited Warranty

IN STORE PICK-UP PRICE
\$2695
OR
\$2845
W/ SHIPPING INCLUDED

**BEAD
BLASTER
SYSTEM**

COMMERCIAL
GRADE

Save Hundreds \$\$\$
When You Buy A
Tire Changer/Wheel Balancer
Combo



Atlas 200 And 700
Series Tire Changers
Can Be Converted
Into Motorcycle/ATV
Tire Changers

Motorcycle/ATV Flip Adapters



ATTC-MC/ATV

IN STORE PICK-UP PRICE
\$249
OR
\$264
W/ SHIPPING INCLUDED

Deluxe ATV Adapters



ATTC-DX-ATV

IN STORE PICK-UP PRICE
\$199
OR
\$214
W/ SHIPPING INCLUDED

This complete Atlas Deluxe ATV adapter kit is designed to decrease the external jaw clamping range of the 200 and 700 series Atlas wheel clamp tire changers.

Deluxe Motorcycle Adapters

IN STORE PICK-UP PRICE
\$199
OR
\$214
W/ SHIPPING INCLUDED

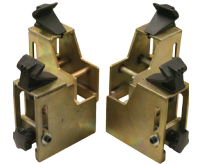

ATTC-DX-MC-SPJ

Small Plastic Jaw Protectors



ATTC-SPJP

- Set of four
- Helps to prevent rim damage on custom rims
- Designed for the Deluxe ATV and Deluxe Motorcycle adapters

IN STORE PICK-UP PRICE
\$16

Large Plastic Jaw Protectors

Large Plastic Jaw Protectors are used on the tire changer turntable jaws to help prevent rim damage on custom aluminum and alloy rims.



Set of four

IN STORE PICK-UP PRICE
\$20
ATTC-LPJP

Plastic Inserts For Mount / Demount Heads

Replacement plastic inserts for Atlas 200 and 700 series tire changers.



IN STORE PICK-UP PRICE
\$16
TAXP-MHPP

Right Assist Arm

The Atlas RH assist arm is the perfect complement to the Atlas LH assist arm when you need to change extremely stiff sidewall and run flat tires.

Visit Our Website
**FOR MORE
Product Photos
AND DETAILED SPECIFICATIONS**



IN STORE PICK-UP PRICE
\$500
OR
\$625
W/ SHIPPING INCLUDED

Left Assist Arm

The ATLAS LH assist arm is designed to be mounted on wheel clamp tire changers.

IN STORE PICK-UP PRICE
\$700
OR
\$850
W/ SHIPPING INCLUDED



E-Z Arm

The Atlas E-Z arm (mounted on the right side) performs almost all the same functions as the dual arms.

IN STORE PICK-UP PRICE
\$595



PRICES SUBJECT TO CHANGE
VISIT OUR WEBSITE
FOR CURRENT PRICING
AND SPECIALS

Dual Assist Arm

The Atlas DAA is the combination of the Atlas LH assist arm and the Atlas RH assist arm.



IN STORE PICK-UP PRICE
\$1000
OR
\$1150
W/ SHIPPING INCLUDED

Atlas Center Post Adapter

The Atlas center post adapter was designed to eliminate the possibility of jaw damage to decorative automotive rim. Makes any wheel clamp tire changer as versatile as a center post tire changer.



IN STORE PICK-UP PRICE
\$499

WATCH OUR VIDEO ONLINE!

Quick Change Head Assembly



IN STORE PICK-UP PRICE
\$199
OR
\$214
W/ SHIPPING INCLUDED

INCLUDES:

WATCH OUR VIDEO ONLINE!

ATTC-QCHAK

Change from a metal head to plastic head in 5 seconds!

Atlas ABS Bead Blaster

The (ABS) Atlas Bead Seater delivers a large volume of air in a very short amount of time to help seat the beads on the most stubborn of tires. The ABS is portable so that it can be used in the shop or in the field.



IN STORE PICK-UP PRICE
\$199
OR
\$225
W/ SHIPPING INCLUDED

ATTC-ABS

The ABS works well on ATV tires all the way up to semi truck tires.

Pneumatic Portable Wheel Lift

The Atlas pneumatic portable wheel lift (AEZWL) is the perfect solution to prevent back injuries when lifting large wheel assemblies onto the shaft of a wheel balancer or on onto tire changer turntable. Today's wheels and tires are getting bigger and heavier. Many wheels are expensive and can be easily scratched or damaged. The Atlas wheel pneumatic wheel lift will lift a 180 pound wheel easily and allow the operator to maneuver the wheel into the correct position without fear of wheel damage or back strain. The AEZWL operates on 120 PSI air pressure.



IN STORE PICK-UP PRICE
\$399
OR
\$549
W/ SHIPPING INCLUDED

ATTC-AEZWL

IN STORE PICK-UP PRICE
\$429
OR
\$579
W/ SHIPPING INCLUDED

New Model Available

- Capacity: 180 LBS.
- 3" Poly Casters
- Max. Lifting Height: 40 1/2"
- Min. Lifting Height: 5 1/2"
- Arm Length: 12"
- Distance Between Arms: 10"
- Overall Height: 67 3/4"
- Required Air Pressure: 120 psi
- Shipping Weight: 175 LBS.

Visit Our Website FOR MORE Product Photos AND DETAILED SPECIFICATIONS

Atlas Aluminum Bead Seater

The Atlas Aluminum Bead Seater delivers a large volume of air in a very short amount of time to help seat the beads on the most stubborn of tires, from small passenger tires up to large over the road semi tires.



IN STORE PICK-UP PRICE
\$279
OR
\$295
W/ SHIPPING INCLUDED

RM-DSR7

Portable Lightweight Construction

Atlas Wheel Lift

The ATLAS wheel lift can be mounted on the Atlas 200 and 700 series wheel clamp tire changer. This wheel lift is a great back saver. The Atlas wheel lift can raise a 150 pound wheel assembly into the correct position for placement onto the turntable.

Fits Atlas 200 And 700 Series Tire Changers



IN STORE PICK-UP PRICE
\$299
OR
\$424
W/ SHIPPING INCLUDED

ATTC-WL-2

Portable Bead Breaker

Great for farm and truck tires. Dimensions: 19" L x 5 1/2" W x 13" T. Max. Opening of Jaws: 5". Size of inlet for coupler or fitting: 5/8" pipe thread. Fits All Types Of Rims. Works With Plastic Air/Hydraulic Pump (HTTLA5100). Shipping Weight: 34 lbs.



IN STORE PICK-UP PRICE
\$215
OR
\$249
W/ SHIPPING INCLUDED

HTTLA5200

Hands Free Clamp

The ATLAS hands-free clamp is the perfect solution to help mount the stiff sidewall tires found on many of today's vehicles.



IN STORE PICK-UP PRICE
\$49

WATCH OUR VIDEO ONLINE!

ATTC-HFC

Bench Vises

Great for home shops or commercial applications. These Bench Vises feature serrated jaws for better gripping, a swivel base for versatility, and a built in anvil.

5 Inch Jaw Width



IN STORE PICK-UP PRICE
\$75
OR
\$119
W/ SHIPPING INCLUDED

HTVISE-5

6 Inch Jaw Width



IN STORE PICK-UP PRICE
\$105
OR
\$167
W/ SHIPPING INCLUDED

HTVISE-6

10 Inch Jaw Width



IN STORE PICK-UP PRICE
\$270
OR
\$420
W/ SHIPPING INCLUDED

HTVISE-10

100 TON Air/Hydraulic

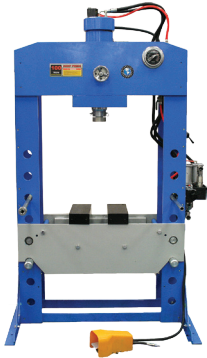

IN STORE PICK-UP PRICE
\$4150
OR
\$4400
W/ SHIPPING INCLUDED
HT0813GG

*Color May Vary

FEATURES

- Measurement between uprights: 31 1/2"
- Base measurement: 47 1/4" W x 39 1/4" L
- Overall height: 6' 10" (82")
- Includes Pressing Blocks
- Sliding ram assembly
- Shipping weight: 1,550 lb.

75 TON Electric/Hydraulic



IN STORE PICK-UP PRICE
\$3595
HT0882

*Color May Vary

FEATURES

- Measurement between uprights: 31 1/2"
- Base measurement: 45" W x 31 1/2" L
- Overall height: 6' 1" (73")
- Includes Pressing Blocks
- Sliding ram assembly
- 110V Motor
- Shipping Weight: 1,225 lb.

75 TON Air/Hydraulic

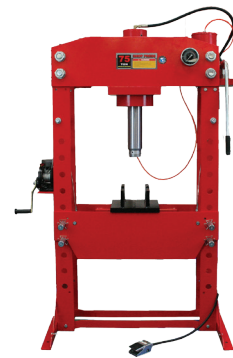

IN STORE PICK-UP PRICE
\$2330
OR
\$2580
W/ SHIPPING INCLUDED
HT0812-GG

FEATURES

- Measurement between uprights - 31 1/2"
- Base measurement: 45" W x 31 1/2" L
- Overall height: 5' 10 5/8" (70 5/8")
- Includes Pressing Blocks
- Sliding ram assembly
- Shipping weight: 1,140 lb.

50 TON Air/Hydraulic

IN STORE PICK-UP PRICE
\$1999
OR
\$2149
W/ SHIPPING INCLUDED
HT0811-GG

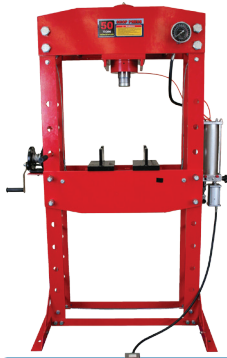

FEATURES

- Measurement between uprights: 28 1/2"
- Base measurement: 40 3/4" W x 31 1/2" L
- Overall height: 6' 10" (76 1/2")
- Ram assembly position adjustable side to side
- Includes Pressing Blocks
- Shipping weight: 800 lbs.

45 TON Air/Hydraulic

IN STORE PICK-UP PRICE
\$1049
OR
\$1199
W/ SHIPPING INCLUDED
HT0807-GG

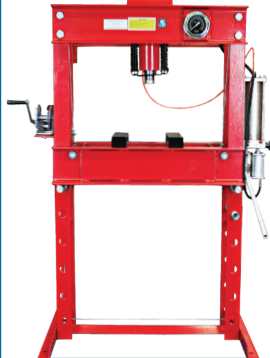

FEATURES

- Measurement between uprights: 32 1/4"
- Working Height: 31 1/2"
- Base measurement: 44" W x 31 1/2" L
- Overall height: 5' 7 1/4" (67 1/4")
- Includes Pressing Blocks
- Shipping weight: 730 lbs.

40 TON Air/Hydraulic

IN STORE PICK-UP PRICE
\$795
OR
\$945
W/ SHIPPING INCLUDED
HT0806



FEATURES

- Measurement between uprights: 25 1/2"
- Working Height: 41"
- Base measurement: 38" W x 34" L
- Overall height: 6' 3" (75")
- Includes Pressing Blocks
- Shipping Weight: 540 Lb.

30 TON Air/Hydraulic

IN STORE PICK-UP PRICE
\$840
OR
\$990
W/ SHIPPING INCLUDED
HT070808A



FEATURES

- Pressure gauge
- Air or manual operation
- Pressing blocks
- 6 positions for pressing bed
- Distance between uprights: 21 1/4"
- Working Height: 34 1/4"
- Dimensions of base: 32" L x 27 1/2" W
- Overall Height: 75 1/2" (6' 3 1/2")
- Shipping weight: 335 lb.

20 TON Air/Hydraulic
W/ Gauge

IN STORE PICK-UP PRICE
\$400
OR
\$550
W/ SHIPPING INCLUDED
HT0805



FEATURES

- Measurement between uprights: 21 1/2"
- Working Height: 38 1/2"
- Base measurement: 29" W x 27" L
- Overall height: 6' (72")
- Ram assembly position adjustable side to side
- Includes Pressing Blocks
- Shipping Weight: 217 Lb.

20 TON Air/Hydraulic



IN STORE PICK-UP PRICE
\$295
OR
\$445
W/ SHIPPING INCLUDED
HT0704-KIT

FEATURES

- Measurement between uprights: 21 1/8"
- Working Height: 29 1/2"
- Base measurement: 25" W x 28" L
- Overall height: 5' (60")
- Includes Pressing Blocks
- Shipping weight: 174 lb.

20 TON Hydraulic



IN STORE PICK-UP PRICE
\$230
OR
\$380
W/ SHIPPING INCLUDED
HT0702-KIT

FEATURES

- Measurement between uprights: 21 1/2"
- Working Height: 30 1/2"
- Base measurement: 25" W x 28" L
- Overall height: 5' (60")
- Includes Pressing Blocks
- Shipping weight: 164 lb.

12 TON Hydraulic



IN STORE PICK-UP PRICE
\$245
OR
\$395
W/ SHIPPING INCLUDED
HT0803

FEATURES

- Measurement between uprights: 20"
- Working Height: 36 1/4"
- Base measurement: 27" W x 20" L
- Overall height: 5' 6" (66")
- Includes Pressing Blocks
- Shipping weight: 163 lb.

SERVICE JACKS

WE ARE NOT RESPONSIBLE FOR MISPRINTS.
PRICES AND SPECIFICATIONS ARE SUBJECT TO CHANGE.

35/22 Ton Air/Hydraulic Two Stage Service Jack

The full hydraulic model is operated by either the handle or the foot pedal. The air/hydraulic model can be operated by air pressure or can be manually operated.

IN STORE PICK-UP PRICE

\$399

HT1912

Visit Our Website
FOR MORE
Product Photos
AND DETAILED SPECIFICATIONS



FEATURES

- 35 Ton Capacity
- Fully Lowered: 8 1/4"
- Fully Raised: 17 1/4"
- Two Heavy Duty 8" Rubber Wheels
- Commercial Grade
- Overall Length: 22"
- Overall Width: 7 7/8"
- Overall Width: 41 1/2"
- Shipping Weight 120 lb.

5 Ton Hydraulic or Air/Hydraulic Low Profile Jack

The full hydraulic model is operated by either the handle or the foot pedal. The air/hydraulic model can be operated by air pressure or can be manually operated.

IN STORE PICK-UP PRICE

\$625

OR

\$775

W/ SHIPPING INCLUDED

FEATURES

- 5 Ton Capacity
- Fully Lowered: 6 1/2"
- Fully Raised: 26"
- Rear swivel casters makes positioning under vehicles easy
- Commercial Grade
- Overall Length: 57"
- Overall Width: 15"
- Saddle Diameter: 5 1/8"
- Shipping Weight 245 lb.



10 Ton Hydraulic or Air/Hydraulic Low Profile Floor Jack

The full hydraulic model is operated by either the handle or the foot pedal. The air/hydraulic model can be operated by air pressure or can be manually operated.

Air/Hydraulic

IN STORE PICK-UP PRICE

\$750

OR

\$900

W/ SHIPPING INCLUDED

HTALFJ10

Hydraulic

IN STORE PICK-UP PRICE

\$590

OR

\$740

W/ SHIPPING INCLUDED

HTLFJ10

PRICES SUBJECT TO CHANGE
VISIT OUR WEBSITE
FOR CURRENT PRICING
AND SPECIALS

FEATURES

- 10 Ton capacity
- Fully Lowered: 8 1/2"
- Fully Raised: 23"
- Rear swivel casters makes positioning under vehicles easy
- Commercial grade
- Overall Length: 62"
- Overall Width: 20"
- Saddle Diameter: 5 7/8"
- Shipping Weight 366 lb.



2 Ton Hydraulic or Air/Hydraulic Low Profile Floor Jack

This 2 ton capacity low profile floor jack will fit under almost any vehicle and is great for shop or home use. The long, low design of this floor jack along with the rear swivel casters make it easy to move and place. Foot pump operated.

Hydraulic

IN STORE PICK-UP PRICE

\$240

OR

\$390

W/ SHIPPING INCLUDED

HTLFJ2

FEATURES

- 2 Ton Capacity
- Fully Lowered (Pad Height): 5 1/4"
- Fully Raised: 31"
- Rear Swivel Casters Make Positioning Under Vehicles Easy
- Foot Pump Operated
- Commercial Grade
- Overall Length: 54"
- Overall Width: 17 1/2"
- Saddle Diameter: 4 7/8"
- Shipping Weight: 143 lb.



Air/Hydraulic

IN STORE PICK-UP PRICE

\$485

OR

\$635

W/ SHIPPING INCLUDED

HTALFJ2



The full hydraulic model is operated by either the handle or the foot pedal. The air/hydraulic model can be operated by air pressure or can be manually operated.

Air Bumper Jack

The 2,500 lb capacity bumper jack has an air control valve for easy raising and lowering of a load. This vehicle end lift also features an adjustable bumper extension with rubber mounting pads. This bumper jack has solid rubber tires in the rear, making it easy to move this jack in and out of position.

FEATURES

- Weight capacity: 2,500 LB.
- Height range: 10"-30"
- Air Pressure: 120-180 psi
- Air operated
- Shipping weight: 250 LB.

IN STORE PICK-UP PRICE

\$445

OR

\$595

W/ SHIPPING INCLUDED

HTEL1.5



PRICES SUBJECT TO CHANGE
VISIT OUR WEBSITE
FOR CURRENT PRICING
AND SPECIALS

22 Or 35 Ton Air/Hydraulic Jack

- 3 adapters included
- Minimum height: 10"
- Maximum lifting height [w/ included adapter] 18" (22 ton) / 25" (35 ton)

22 Ton
IN STORE PICK-UP PRICE

\$270

OR

\$420

W/ SHIPPING INCLUDED

HT1902

Shipping Weight: 90 lb.

35 Ton
IN STORE PICK-UP PRICE

\$370

OR

\$520

W/ SHIPPING INCLUDED

HT1903

Shipping Weight: 108 lb.



2 Bag Air Jack

IN STORE PICK-UP PRICE

\$249

OR

\$320

W/ SHIPPING INCLUDED

HT3101-NEW

- Air operated
- 4,300 LB. capacity
- Maximum height: 12 1/2"



3 Bag Air Jack

IN STORE PICK-UP PRICE

\$279

OR

\$344

W/ SHIPPING INCLUDED

HT3102-NEW

- Air operated
- 3,500 LB. capacity
- Maximum height: 15"



Adjustable Air Seat

- Foam padded seat for maximum comfort
- Five swivel caster wheels for easy moving
- Height adjustable from 15" to 19 1/4"
- Seat swivels 360 degrees
- Shipping Weight: 15 lb.

HTSEAT-1

IN STORE PICK-UP PRICE

\$35

OR

\$52

W/ SHIPPING INCLUDED

MORE
MODELS
AVAILABLE
ON OUR
WEBSITE



Power Train Lift

2,500 LB. CAPACITY

This lift table handles power train components like engines and their transmissions, engines with trans-axle assemblies, rear ends and large electric vehicle batteries. It will also serve as a work table where components can be lowered to a convenient work height for repairs.



Max. Lifting Height: 80" (6' 8")

HT6400

IN STORE PICK-UP PRICE
\$1670
OR
\$1820
W/ SHIPPING INCLUDED

FEATURES

- Scissor lift design provides easy 360° access to any component
- Table top height from 33" to 80"
- Four 8" diameter rubber coated swivel caster wheels for easy maneuverability with even the heaviest loads
- Wheels can be locked in position for steering, rear wheels can be locked to prevent the lift from rolling
- Removable air/hydraulic power unit provides hands free operation anywhere around the lift's perimeter
- Adjusting screws tilt the table + or - 15 degrees side to side, or fore and aft, ensures maximum stability of the table in any position

Power Train Lift

1,250 LB. CAPACITY



Max. Lifting Height: 55" (4' 7")

HTPTLIFT

IN STORE PICK-UP PRICE
\$850
OR
\$1000
W/ SHIPPING INCLUDED

WATCH OUR VIDEO ONLINE!

FEATURES

- 1,250 Lb. Capacity
- Air/Hydraulic Operated
- Movable Power Unit For Easier Hands Free Operation
- Fully Adjustable Saddle
- Heavy Duty Steel Swivel Casters For Easy Positioning
- Shipping weight: 300 LBS.

2,000 LB. Capacity Folding Engine Stand

IN STORE PICK-UP PRICE
\$115
OR
\$265
W/ SHIPPING INCLUDED



- Rear swivel casters
- Rotating backing plate

1,250 LB. Capacity Engine Stand

IN STORE PICK-UP PRICE
\$60
OR
\$127
W/ SHIPPING INCLUDED



- Fully adjustable mounting head
- Shipping Weight: 67 LBS.



2 Ton Air/Hydraulic Foldable Engine Crane

HT72501

- Air/hydraulic operated
- Adjustable telescoping boom - 4 different positions
- Used for maneuvering engines, transmissions, or heavy loads
- Large diameter ram makes lifting easy
- Shipping Weight: 250 LBS.

IN STORE PICK-UP PRICE
\$360
OR
\$510
W/ SHIPPING INCLUDED

3 Ton Hydraulic Engine Crane

The 3 Ton Hydraulic Engine Crane is strong, durable, versatile, and a real space saver! This Cherry Picker's strong design allows for maximum lifting power for a minimum of shop space.

- 3 Ton Capacity
- Hydraulic operated
- Used for maneuvering engines, transmissions, or heavy loads
- Adjustable length legs for stability
- Large diameter ram makes lifting easy
- Shipping Weight: 250 LBS.

HT73001

IN STORE PICK-UP PRICE
\$445
OR
\$595
W/ SHIPPING INCLUDED

Engine Cradle

- 1000 lb. capacity
- Fits most Small Block Chevy engines
- FOUR heavy duty casters for easy maneuverability
- Used for storing, transporting, and working on "in progress" engines
- Low design for maximum stability when working on engines
- Shipping Weight: 21 LBS.

IN STORE PICK-UP PRICE
\$30
OR
\$51
W/ SHIPPING INCLUDED

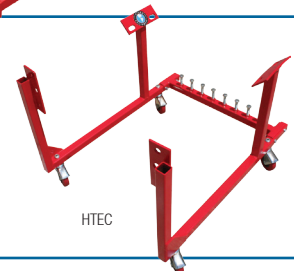

HTEC

600 LB. Engine Support Bar

- Minimum Width: 44 1/2"
- Maximum Width: 62"
- Shipping Weight: 33 LBS.



HT1703

IN STORE PICK-UP PRICE
\$45
OR
\$78
W/ SHIPPING INCLUDED

1000 LB. Engine Support Bar

- Fully Adjustable Working Width
- Overall Width: 59"
- Shipping Weight: 41 LBS.



HT1701

IN STORE PICK-UP PRICE
\$60
OR
\$101
W/ SHIPPING INCLUDED

12 Ton Hydraulic Pipe Bender

IN STORE PICK-UP PRICE
\$150
OR
\$300
W/ SHIPPING INCLUDED

- Heavy duty cast iron dies, from 1/2" to 2"
- Spring return ram for fast ram retraction

HTPB12



12 Ton Air/Hydraulic Pipe Bender

IN STORE PICK-UP PRICE
\$195
OR
\$345
W/ SHIPPING INCLUDED

- Air or manual operated
- Adjustable top rollers for degree of bends up to 90°

HTPB12-AIR

16 Ton Hydraulic Pipe Bender

IN STORE PICK-UP PRICE
\$245
OR
\$395
W/ SHIPPING INCLUDED

- 9 1/2" jack stroke
- Horizontal and vertical positions
- Spring return rams for fast ram retraction
- 8 Heavy duty cast iron dies from 1/2" to 3"
- Adjustable top rollers for a degree of bends up to 90°



HTPB16

16 Ton Air/Hydraulic Pipe Bender

IN STORE PICK-UP PRICE
\$290
OR
\$440
W/ SHIPPING INCLUDED

- 9 1/2" jack stroke
- 100 - 120 working PSI
- Air or manual operated
- Horizontal and vertical positions
- Spring return rams for fast ram retraction
- 8 Heavy duty cast iron dies from 1/2" to 3"
- Adjustable top rollers for a degree of bends up to 90°

HTPB16-AIR

3.5 Gallon Parts Washer

IN STORE PICK-UP PRICE

\$50

OR

\$66

W/ SHIPPING INCLUDED

HTPW3.5G



*Color May Vary

FEATURES

- Solvent Capacity: 3 1/2 gallons
- Pump: 4 GPM
- Motor: 110V
- Flexible stainless steel nozzle
- Removable tray
- Heavy duty steel construction
- Lightweight, portable
- Shipping weight: 16 Lb.

20 Gallon Parts Washer

IN STORE PICK-UP PRICE

\$125

OR

\$185

W/ SHIPPING INCLUDED

HTPW20G

*Color May Vary



FEATURES

- 110 volt
- Built in drain
- Shipping Weight: 60 Lb.
- 36" overall height on stand
- Gooseneck spout: 20 1/4" L
- On/off switch with indicator light
- Re-circulates fluid at up to 50 GPH
- Washer dimensions: 30" L x 20" D x 11" H
- 20 gallon steel tank has operating level of 12 gallons
- Extra powerful, heavy duty electric pump is fully enclosed

40 Gallon Parts Washer

IN STORE PICK-UP PRICE

\$180

OR

\$330

W/ SHIPPING INCLUDED

HTPW40G



*Color May Vary

FEATURES

- 110 volt
- Built in drain
- 40 gallon steel tank
- Gooseneck spout: 24" L
- Shipping Weight: 109 Lb.
- 34 3/4" overall height on stand
- On/off switch with indicator light
- Re-circulates fluid at up to 50 GPH
- Washer dimensions: 43 1/8" L x 20 3/4" D x 10 1/2" H
- Extra powerful, heavy duty electric pump is fully enclosed

SWC-500 Heated Spray Wash Cabinet

The SWC-500 Spray Wash Cabinet is the ideal parts washer for any automotive repair or transmission shop.

IN STORE PICK-UP PRICE

\$3495

OR

\$3645

W/ SHIPPING INCLUDED

PORTABLE!

SL-STD-500-KIT



LARGER TANK

STD-750

FEATURES

- 50 Gallon Tank
- Automatic cleaning
- Uses eco-friendly soap and hot water
- Casters provide mobility
- Parts basket and hang tree
- Timer with auto shut-off
- Front loading design
- Cleans small and large parts
- Oil skimmer
- Turntable rotates at 3 rpm
- 3/16" vents spray solution at 30-60 GPM
- Solution is filtered and recycled
- One Year Parts Warranty
- Shipping Weight: 750 Lbs.

SWC-750 Heated Spray Wash Cabinet

The SWC-750 is designed to handle light diesel engines and engine parts for the truck repair and maintenance trade. It is a full foot taller than our standard SWC-500.

IN STORE PICK-UP PRICE

\$3995

OR

\$4145

W/ SHIPPING INCLUDED

FEATURES

- 53 Gallon Tank
- Automatic cleaning
- Uses eco-friendly soap and hot water
- Casters provide mobility
- Heavy duty pump
- Timer with auto shut-off
- Front loading design
- Cleans small and large parts
- Oil skimmer
- Turntable rotates at 3 rpm
- 3/16" vents spray solution at 30-60 GPM
- Solution is filtered and recycled
- Load capacity: 1,250 lbs.
- One Year Parts Warranty
- Shipping weight: 960 lbs.

Tire Rack Carrier

IN STORE PICK-UP PRICE

\$230

OR

\$380

W/ SHIPPING INCLUDED

HTT250



Tire Inflation Cage

IN STORE PICK-UP PRICE

\$545

OR

\$695

W/ SHIPPING INCLUDED

HT400



1,000 LB. Dual Wheel Dolly

The hydraulic system on this Dual Wheel Dolly makes it easy to remove and install dual wheel assemblies.

FEATURES

- 1,000 LB. Capacity
- Working range: 3 1/2" - 10 3/4"
- 6 ft. support Chain included
- Two mounting positions for Lift Arms
- Steel wheel casters: two 3 1/2" stationary in front & one 3 1/2" swivel in rear
- Floor Dimensions: 40" L x 40" W
- Height: 29 1/4" - 35 1/4"
- Lift Arm Length: 23 3/4"
- Lift Arm Spread: Outer Position 25" Inner Position 21"
- Lift: 6 1/4"
- Shipping Weight: 150 lbs

IN STORE PICK-UP PRICE

\$245

OR

\$395

W/ SHIPPING INCLUDED



HT2301

Heavy Duty Wheel Dolly

This Heavy Duty Wheel Dolly is perfect for farm and shop use. This wheel dolly works with large truck wheel assemblies, implement tires, farm tractors and machinery, and other equipment requiring wheel changes. This dolly features hydraulic lifting action and heavy duty rollers which make it easy to lift tires for moving and the heavy duty swivel casters which make it a snap to transport wheels from one location to another.

IN STORE PICK-UP PRICE

\$990

OR

\$1140

W/ SHIPPING INCLUDED

FEATURES

- 2,600 LB. capacity
- Accommodates wheel diameters from 39" - 83"
- Maximum wheel width: 31 1/2"
- Hydraulic
- Shipping Weight: 330 LBS

2,600 LB CAPACITY



HT712001

1,500 LB. Heavy Duty Wheel Dolly

The hydraulic system on this heavy duty Dual Wheel Dolly makes it easy to remove and install dual wheel assemblies from even the largest truck.

FEATURES

- 1500 lb capacity
- For wheels up to 52" diameter
- 6 ft. Support Chain included
- Steel wheel roller bearing casters: two 3 1/2" in front & one 3" in rear
- Tilt Frame and Rolling Lift Arms for easy positioning of dual wheel assemblies.
- Overall Dimensions: 43" W x 51" L x 35" H
- Lift Arm Length: 26"
- Lift Arm Spread: 21" - 25"
- Lift: 9 1/4"
- Ram Travel 4 3/4"
- Shipping weight: 155 lbs.

HT90751



IN STORE PICK-UP PRICE

\$215

OR

\$365

W/ SHIPPING INCLUDED

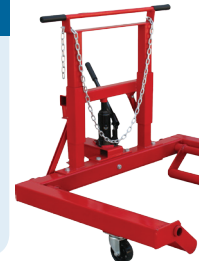

Tire Caddy

IN STORE PICK-UP PRICE

\$155

OR

\$185

W/ SHIPPING INCLUDED

FEATURES

- Adjustable Width makes it easy to load without using your hands.
- Handles Tires Stacked up to 5 Ft. High
- Maximum Width: 30 inches
- Minimum Width: 12 inches
- Caddy Height: 60 inches
- Shipping Weight: 66 lb.



HTT400



AF1

Portable 20 Gallon

These dynamite portable 110 volt electric air compressors deliver enough air for the average two man motorcycle shop.



IN STORE PICK-UP PRICE
\$395
OR
\$549
W/ SHIPPING INCLUDED

Specifications

Motor Peak	5.0 Horsepower
Motor Running	2.0 Horsepower
Delivered-CFM 40PSI	7.1
Delivered-CFM 90PSI	5.5
Pressure Setting	90 lb.-135 lb.
Power	110V

AF2

Portable 20 Gallon

These are belt driven reciprocating air compressors with a rebuildable cast iron twin cylinder single stage pumps.



IN STORE PICK-UP PRICE
\$549
OR
\$799
W/ SHIPPING INCLUDED

Specifications

Motor Peak	5.0 Horsepower
Motor Running	2.0 Horsepower
Delivered-CFM 40PSI	7.1
Delivered-CFM 90PSI	5.5
Pressure Setting	90 lb.-135 lb.
Power	110V
Shipping Weight	250 Lb.

AF3

Single Stage 60 Gallon



This 220 volt single stage air compressor is the perfect compressor for the one or two man automotive service center.

IN STORE PICK-UP PRICE
\$849
OR
\$1099
W/ SHIPPING INCLUDED

Specifications

Motor Peak	6.0 Horsepower
Motor Running	3.2 Horsepower
Delivered-CFM 40PSI	12.0
Delivered-CFM 90PSI	10.5
Pressure Setting	90 lb. - 135 lb.

AF4

Single Stage 60 Gallon

This compressor utilizes a three cylinder single stage pump as compared to the two cylinder pump on the Atlas AF3. The Atlas AF4 also employs a slightly more efficient motor than the Atlas AF3. The Atlas AF4 produces "faster" air for the shop operator who cannot wait. The no-load recovery time (90 LB. to 135 LB.) for the Atlas AF4 is twice as fast as the Atlas AF3. (1 minute and 40 seconds.)



IN STORE PICK-UP PRICE
\$949
OR
\$1199
W/ SHIPPING INCLUDED

Visit Our Website FOR MORE Product Photos

FEATURES

- Quiet Operation
- Heavy Duty Metal Belt Guard
- Shipping Weight: 380 lb.
- Vibro-isolator Pads

Specifications

Motor Peak	7.0 Horsepower
Motor Running	3.4 Horsepower
Delivered-CFM 40PSI	15.0
Delivered-CFM 90PSI	13.7
Pressure Setting	90 lb. - 135 lb.

AF5

Single Stage 60 Gallon

This compressor is equipped with an oversized three (3) cylinder cast iron single stage reciprocating pump that produces a large volume of air at a very competitive price. The Atlas AF5 is our lowest priced air compressor that is capable of delivering enough air to effectively run our SBC 420 sandblast cabinet (when used with #8 or #10 glass beads). The Atlas AF5 does not produce enough air to "run" the sandblast cabinet for an extended period of time, but does produce a sufficient volume and pressure to operate the machine for ten minute intervals.



IN STORE PICK-UP PRICE
\$999
OR
\$1249
W/ SHIPPING INCLUDED

FEATURES

- Quiet Operation
- Heavy Duty Metal Belt Guard
- Shipping Weight: 390 lb.
- Vibro-isolator Pads

Specifications

Motor Peak	6.5 Horsepower
Motor Running	4.5 Horsepower
Delivered-CFM 40PSI	20.0
Delivered-CFM 90PSI	18.0
Pressure Setting	90 lb. - 135 lb.

AF6

Two Stage 80 Gallon

This is our entry level, two-stage air compressor. This unit operates between 140 LB. and 175 LB. PSI. The Atlas AF6 will run the SBC 420 sandblast cabinet (when used with #8 or #10 glass beads). The combination of the commercial grade low RPM motor and heavy duty 3 cylinder (2 cylinders are low pressure and one cylinder is high pressure) cast iron reciprocating air compressor pump delivers an incredible amount of air volume and air pressure for a very low price.

IN STORE PICK-UP PRICE
\$1249
OR
\$1499
W/ SHIPPING INCLUDED



FEATURES

- Quiet Operation
- Heavy Duty Metal Belt Guard
- Shipping Weight: 485 lb.
- Vibro-isolator Pads

Specifications

Motor Running	5.0 Horsepower
Delivered-CFM 100PSI	15.0
Delivered-CFM 175PSI	14.0
Pressure Setting	145 lb. - 175 lb.
Power	220V Single Phase

AF7

Two Stage 80 Gallon

This is the perfect compressor for the 3-4 man auto shop, or for the one man shop that wants to be prepared for future growth.



WATCH OUR VIDEO ONLINE

IN STORE PICK-UP PRICE
\$1349
OR
\$1599
W/ SHIPPING INCLUDED

COMMERCIAL GRADE

Specifications

Motor Running	5.0 Horsepower
Delivered-CFM 10PSI	15.0
Delivered-CFM 175PSI	14
Pressure Setting	145 lb. - 175 lb.
Motor Voltage	230VAC 1PH

FEATURES

- Mounted Magnetic Starter
- Heavy Duty Metal Belt Guard
- Shipping Weight: 485 lb.
- Vibro-isolator Pads

AF8

Two Stage 80 Gallon

FEATURES

- Quiet Operation
- Heavy Duty Metal Belt Guard
- Shipping Weight: 589 lb.
- Vibro-isolator Pads



IN STORE PICK-UP PRICE
\$1599
OR
\$1859
W/ SHIPPING INCLUDED

Specifications

Motor Running	5.0 Horsepower
Delivered-CFM 100PSI	19.6
Delivered-CFM 175PSI	18.4
Pressure Setting	145 lb. - 175 lb.
Motor Voltage	230VAC 1PH

INCLUDES THESE ADDITIONAL FEATURES:

Visit Our Website FOR MORE Product Photos

COMMERCIAL GRADE

AF8 Plus

Two Stage 80 Gallon

The "PLUS" features for our commercial grade two stage air compressors include a low oil monitor, automatic tank drain, and air cooled aftercooler. These three feature help to extend the life of your Atlas air compressor while also delivering "better air".

IN STORE PICK-UP PRICE
\$1849
OR
\$2099
W/ SHIPPING INCLUDED

Low Oil Shut Off



Auto Drain



Air Aftercooler



AF9/17

Two Stage 80 Gallon

The Atlas AF9/17 is capable of providing adequate air for the medium to large shop owner.



IN STORE PICK-UP PRICE
\$1949
OR
\$2199
W/ SHIPPING INCLUDED

COMMERCIAL
GRADE

FEATURES

- 1725 RPM Motor
- Quiet Operation
- Magnetic Starter
- Heavy Duty Metal Belt Guard
- Vibro-isolator Pads
- Shipping Weight: 627 lb.

Specifications

Motor Running	7.5 Horsepower
100PSI	24.8
Delivered-CFM 175PSI	22.8
Pressure Setting	145 - 175
Tank Capacity	80 Gal.
Motor Voltage	230VAC 1PH 60Hz

AF9/17 Plus

Two Stage 80 Gallon

The "PLUS" features for our commercial grade two stage air compressors include a low oil monitor, automatic tank drain, and air cooled aftercooler. These three feature help to extend the life of your Atlas air compressor while also delivering "better air".

COMMERCIAL
GRADE

IN STORE PICK-UP PRICE
\$2249
OR
\$2499
W/ SHIPPING INCLUDED



INCLUDES THESE ADDITIONAL FEATURES:

Automatic Low Oil Shut Off



Auto Tank Drain



Air Aftercooler

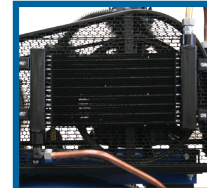

AF10 Plus

1 Phase And 3 Phase
Two Stage 120 Gallon

The Atlas Air Force AF-10 is available in either 1 phase or 3 phase, 10 HP motor configuration. This air compressor is designed for the service center that demands a lot of air! The AF-10 has a 120 gallon ASME certified storage tank. The heavy duty extra large three cylinder two stage pump delivers over 36 CFM @ 175 PSI.

AF10 3-Phase
IN STORE PICK-UP PRICE
\$2949
OR
\$3199
W/ SHIPPING INCLUDED



FEATURES

- Magnetic Starter
- Auto Drain
- Air Aftercooler
- Heavy Duty Metal Belt Guard
- Automatic Low Oil Shut Off
- Vibro-isolator Pads
- Shipping Weight: 969 lb

AF10 1-Phase

IN STORE PICK-UP PRICE
\$3249
OR
\$3499
W/ SHIPPING INCLUDED

Specifications

Motor Running	10 Horsepower
Delivered-CFM 100PSI	38
Delivered-CFM 175PSI	36.3
Pressure Setting	145 lb. - 175 lb.
Tank Capacity	120 Gal.
Motor Voltage	230VAC 1PH or 3PH 60Hz

INCLUDES THESE ADDITIONAL FEATURES:

Automatic Low Oil Shut Off



Aftercooler

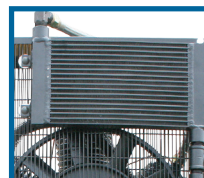

Auto Tank Drain

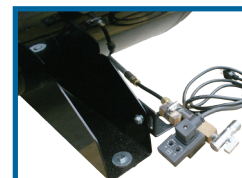

AF15 Plus

Two Stage 120 Gallon

The Atlas Air Force AF-15 Plus is a 3 phase, 15 HP motor configuration. This air compressor is designed for the service center that demands a lot of air! The AF-15 has a 120 gallon ASME certified storage tank. The heavy duty extra large three cylinder two stage pump delivers over 49 CFM @ 175 PSI.

IN STORE PICK-UP PRICE
\$4045
OR
\$4295
W/ SHIPPING INCLUDED

FEATURES

- Magnetic Starter
- Auto Drain
- Air Aftercooler
- Heavy Duty Metal Belt Guard
- Automatic Low Oil Shut Off
- Vibro-isolator Pads



Specifications

Motor Running	15 Horsepower
Delivered-CFM 100PSI	52
Delivered-CFM 175PSI	49
Pressure Setting	145 lb. - 175 lb.
Tank Capacity	120 Gal.
Motor Voltage	230VAC 3PH 60Hz

COMMERCIAL
GRADE

INCLUDES THESE
ADDITIONAL FEATURES:

Aftercooler



Automatic Low Oil Shut Off



Auto Tank Drain

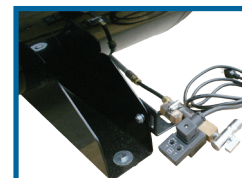

AF17G 
Gas Powered 30 Gallon

This air compressor is equipped with the super reliable Honda GX240 8.0 HP electric start gas engine. The Atlas AF17G gas powered air compressor features a pneumatic throttle control, electric start, vibro-isolator pads, charging system, and head unloaders. This is the perfect air compressor for the highway service truck.

The Atlas AF17G delivers plenty of air to power the large impact wrenches needed to remove those stubborn BUDD wheel lug nuts. The dependable HONDA engine and the Atlas two stage compressor pump are designed and engineered to provide years of service.

IN STORE PICK-UP PRICE
\$1645
OR
\$1895
W/ SHIPPING INCLUDED

COMMERCIAL GRADE



 **FOR MORE**
Product Photos
AND DETAILED SPECIFICATIONS

FEATURES

- Honda GX240 8 HP Electric Start Gas Engine
- Heavy Duty Metal Belt Guard
- Shipping Weight: 630 lbs

Specifications

Motor Running	8.0 Horsepower
Delivered-CFM 100PSI	18
Delivered-CFM 175PSI	16.5
Pressure Setting	145 lb. - 175 lb.
Tank Capacity	30 Gal.
Gasoline Engine	4 Cycle Air Cooled OHV Single cylinder
Starting System	12VDC Electrical or Recoil
Compressor Pump	CT51 2 Cylinder 2 Stage

AF13 
Gas Powered 30 Gallon

This air compressor is equipped with the super reliable Honda GX390 13 HP electric start gas engine. The Atlas AF13 gas powered air compressor features a pneumatic throttle control, electric start, vibro-isolator pads, charging system, and head unloaders. This is the perfect air compressor for the highway service truck.



COMMERCIAL GRADE

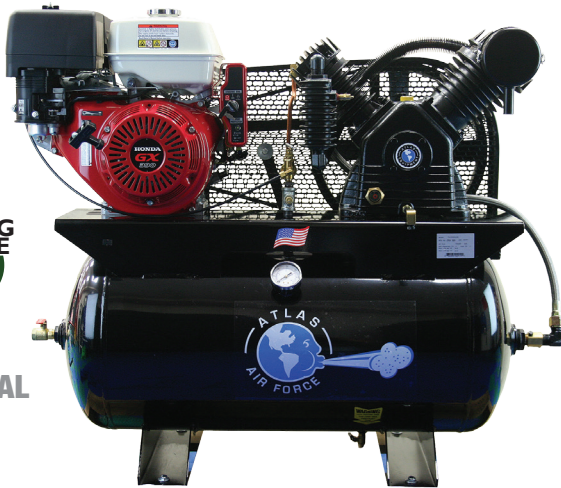

 **FOR MORE**
Product Photos
AND DETAILED SPECIFICATIONS

IN STORE PICK-UP PRICE
\$2049
OR
\$2299
W/ SHIPPING INCLUDED

Designed For Service Trucks

FEATURES

- Honda GX390 13 HP Gas Engine
- Electric Start
- Heavy Duty Metal Belt Guard
- Vibro-isolator Pads
- Shipping Weight: 627 lbs

Specifications

Motor Running	13.0 Horsepower
Delivered-CFM 100PSI	23
Delivered-CFM 175PSI	22
Pressure Setting	145 lb. - 175 lb.
Tank Capacity	30 Gal.
Gasoline Engine	4 Cycle Air Cooled OHV Single cylinder
Starting System	12VDC Electrical or Recoil
Compressor Pump	CT51 2 Cylinder 2 Stage

325 lb. Capacity Table Truck

IN STORE PICK-UP PRICE
\$225
OR
\$405
W/ SHIPPING INCLUDED



Maximum Height: 29"

*Color May Vary

- 325 lb. capacity
- Table Dimensions: 18" wide x 28" long
- Maximum Height 29"
- Minimum Height 9"
- Weight 102 lbs.
- Hydraulic Foot Pedal Operated
- Hand Release Lowering Lever

750 lb. Capacity Scissor Lift Table

IN STORE PICK-UP PRICE
\$420
OR
\$570
W/ SHIPPING INCLUDED



Maximum Height: 54"

*Color May Vary

PRICES SUBJECT TO CHANGE
VISIT OUR WEBSITE FOR CURRENT PRICING AND SPECIALS

- 750 lb. capacity
- Table Top Dimensions: 19.5" wide x 36" long
- Maximum Height 54"
- Minimum Height 14.5"
- Shipping Weight: 220 Lbs.
- Hydraulic Foot Pedal Operated
- Hand Release Lowering Lever

1100 lb. Capacity Table Truck

IN STORE PICK-UP PRICE
\$455
OR
\$605
W/ SHIPPING INCLUDED



Maximum Height: 35"

*Color May Vary

- 1,100 lb. capacity
- Table Dimensions: 20" wide x 32" long
- Maximum Height 35"
- Minimum Height 11.5"
- Weight 260 lbs.
- Hydraulic Foot Pedal Operated
- Hand Release Lowering Lever

Air Operated Grease Pump

Practical, functional and compact, the Atlas Air Operated Grease Pump can be used in all workplaces. Enables quick, high pressure greasing on any motor vehicle or mechanism. Equipped with a grease follower plate that protects the lubricant and ensures positive priming.

IN STORE PICK-UP PRICE
\$200
OR
\$234
W/ SHIPPING INCLUDED

FEATURES

- Portable
- 50:1 pressure ratio
- 5 cu. in./min delivery
- Comes with hose and pump



HT-K5001

THIS PRODUCT
ON DISPLAY
AT OUR SHOWROOM

Stainless Steel, Air Operated Grease Pump

Practical, functional and compact, the Atlas Stainless Steel Air Operated Grease Pump can be used in all workplaces. Enables quick, high pressure greasing on any motor vehicle or mechanism. Equipped with a grease follower plate that protects the lubricant and ensures positive priming.

IN STORE PICK-UP PRICE
\$225
OR
\$259
W/ SHIPPING INCLUDED

FEATURES

- Stainless steel
- Portable
- 50:1 pressure ratio
- 5 cu. in./min delivery
- Comes with hose and pump



HT-K5002

Portable Oil Dispenser

Practical and functional, with a wheel-mounted 17 gallon tank, the Portable Oil Dispenser can be used in all workplaces. The Portable Oil Dispenser has an air-operated pump that is suitable for oils of any density. The Portable Oil Dispenser comes equipped with an aluminum digital oil meter gun.

IN STORE PICK-UP PRICE
\$525
OR
\$675
W/ SHIPPING INCLUDED

FEATURES

- Stainless steel
- Comes with hose, pump, and digital oil meter gun
- 5 cu. in./min delivery
- 3:1 pressure ratio
- Portable
- Level indicator



HT-T726065

Grease Dispensing Trolley Kit

Grease dispensing trolley includes: 50:1 air operated pump with 28" suction tube, 12" drum cover, 12" follower plate, 13' hose, and grease gun. For use with 35 LB. grease pails.

IN STORE PICK-UP PRICE
\$275
OR
\$321
W/ SHIPPING INCLUDED

FEATURES

- 50:1 air operated pump with 28" suction tube
- 12" drum cover
- 12" follower plate
- Grease gun
- Portable



Grease dispensing trolley for use with 35 LB. grease pails

HT-A7701

*Color May Vary

Grease Dispensing Trolley Kit

Grease dispensing trolley includes: 50:1 air operated pump with 37" suction tube, 23 1/2" drum cover, 23" follower plate, and grease gun. For use with 400 LB. grease drums.

IN STORE PICK-UP PRICE
\$355
OR
\$430
W/ SHIPPING INCLUDED

FEATURES

- 50:1 air operated pump with 36" suction tube
- 23 1/2" drum cover
- 23" follower plate
- Grease gun
- Portable



Grease dispensing trolley for use with 400 LB. grease drums

HT-A7801

*Color May Vary

Grease Dispensing Trolley Kit

Grease dispensing trolley includes: 50:1 air operated pump with 37" suction tube, 23 1/2" drum cover, 23" follower plate, 50 ft., 1/4" hose reel, and grease gun. For use with 400 LB. grease drums.

IN STORE PICK-UP PRICE
\$655
OR
\$805
W/ SHIPPING INCLUDED

FEATURES

- 50:1 air operated pump with 36" suction tube
- 50 Ft., 1/2" hose reel
- 23 1/2" drum cover
- 23" follower plate
- Grease gun
- Portable



Grease dispensing trolley for use with 400 LB. grease drums

HT-A7901

*Color May Vary

Oil Dispensing Trolley Kit

This mobile self contained system includes a heavy duty steel trolley platform that can support up to 400 pounds, up to a 55 gallon drum, a 5:1 ratio oil pump, heavy-duty 50 foot lubrication hose reel (and hose), and a digital control dispensing hand gun.

IN STORE PICK-UP PRICE
\$695
OR
\$845
W/ SHIPPING INCLUDED

FEATURES

- Digital oil gun
- 50:1 air operated pump with 36" suction tube
- 50 Ft., 1/2" in. retractable hose reel



HT-K9903

*Color May Vary

50 Ft. Retractable Grease Hose Reel *Color May Vary

FEATURES

- For 50:1 ratio Air Grease Pumps
- Heavy Duty Metal Frame
- Rubber Hose
- Retractable
- Available in both 1/4" and 3/8" ID
- 50 Foot Hose length



Enclosed
1/4" ID
HT-D9306402.015-1/4ID

IN STORE PICK-UP PRICE
\$230

OR
\$280
W/ SHIPPING INCLUDED

OIL / GREASE GUNS AVAILABLE
Call For Details

Enclosed
3/8" ID
HT-D9306402.015-3/8ID

IN STORE PICK-UP PRICE
\$300

OR
\$350
W/ SHIPPING INCLUDED

Pivot Hose Reel Wall Mount

IN STORE PICK-UP PRICE
\$10
HT-A11310



Pivot Hose Reel Wall Mount

IN STORE PICK-UP PRICE
\$10
HT-A11320



360° Swivel Hose Reel Wall Mount

IN STORE PICK-UP PRICE
\$10
HT-A11330



33 Ft./50 Ft. Retractable Air Hose Reel

Heavy Duty Metal Frame

33 Ft.
HTHR-33FT
3/8" ID
Shipping Weight:
27 lbs.

IN STORE PICK-UP PRICE
\$80
OR
\$107
W/ SHIPPING INCLUDED



*Color May Vary

50 Ft.
HTHR-50FT
IN STORE PICK-UP PRICE
\$105
OR
\$145
W/ SHIPPING INCLUDED

Shipping Weight:
40 lbs.

3/8" ID

65 Ft. Retractable Air Hose Reel

IN STORE PICK-UP PRICE
\$185
OR
\$242
W/ SHIPPING INCLUDED

65 Ft.
HTHR-65FT
Shipping Weight: 57 lbs.
1/2" ID



*Color May Vary

Heavy Duty Metal Frame

100 Ft. Retractable Air Hose Reel

Shipping Weight: 63 lbs.



*Color May Vary

100 Ft.
HTHR-100FT
IN STORE PICK-UP PRICE
\$185
OR
\$242
W/ SHIPPING INCLUDED

Heavy Duty Metal Frame 3/8" ID

50 Ft. Retractable Welding Dual-Hose Reel

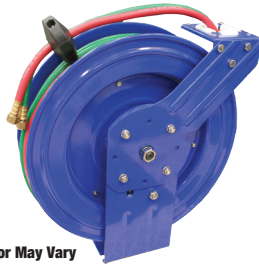

*Color May Vary

50 Ft.
HT-D3205202.015
IN STORE PICK-UP PRICE
\$100
OR
\$145
W/ SHIPPING INCLUDED

Heavy Duty Metal Frame 1/4" ID

75 Ft. Retractable Welding Dual-Hose Reel

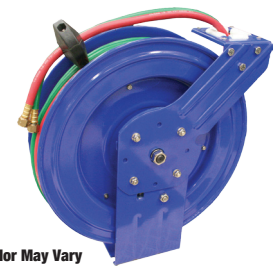

*Color May Vary

75 Ft.
HT-D3305202.023
IN STORE PICK-UP PRICE
\$160
OR
\$210
W/ SHIPPING INCLUDED

Heavy Duty Metal Frame 1/4" ID

100 Ft. Manual Water Hose Reel

Heavy Duty Metal Frame

100 Ft.
HT-D2105104.30
IN STORE PICK-UP PRICE
\$120
OR
\$160
W/ SHIPPING INCLUDED

3/8" ID

*Color May Vary



200 Ft. Manual Water Hose Reel

Heavy Duty Metal Frame

200 Ft.
HT-D2205104.60
IN STORE PICK-UP PRICE
\$175
OR
\$232
W/ SHIPPING INCLUDED

3/8" ID

*Color May Vary



25 Gallon Capacity Steel Gas Caddy

Perfect for homes, shops, marinas, farms, or anywhere you need to easily transport and dispense fuel. The Atlas gas caddy features heavy duty steel construction, rugged solid rubber wheels and a dolly handle for easy portability. Works with gasoline, kerosene, diesel, or mixed fuels.

FEATURES

- Heavy duty steel construction
- Two way rotary pump (for siphoning and dispensing)
- Fluid level gauge
- 8" solid rubber tires
- 8" flexible hose
- Shipping weight 75 lb.

IN STORE PICK-UP PRICE
\$285
OR
\$360
W/ SHIPPING INCLUDED



HTGC

"Move-It" Dollies (Set of 4)

Our "Move-It" dolly system is the easy answer for moving cars in your garage. These dollies allow operators to lift the car in seconds with the built-in jacking mechanism – then just roll the car to the desired location. This unique system makes the need for a separate jack obsolete.

MOVING YOUR VEHICLE IS MUCH EASIER WITH A SET OF "MOVE-IT" DOLLIES!



Hydraulic Style

- 1500 lb. capacity per dolly
- 11" maximum distance closed
- 22" maximum distance open
- 12" width of wheel guard

IN STORE PICK-UP PRICE
\$100
OR
\$143
W/ SHIPPING INCLUDED

Each

OR

IN STORE PICK-UP PRICE
\$395
OR
\$545
W/ SHIPPING INCLUDED

Set Of 4



HTMD

Ratchet Style

- 1250 lb. capacity per dolly
- 11" maximum distance closed
- 23" maximum distance open
- 9" width of wheel guard

IN STORE PICK-UP PRICE
\$85
OR
\$123
W/ SHIPPING INCLUDED

Each

OR

IN STORE PICK-UP PRICE
\$345
OR
\$495
W/ SHIPPING INCLUDED

Set Of 4



HTMDRS

"Move-It" Dolly Storage Rack



IN STORE PICK-UP PRICE
\$35
OR
\$58
W/ SHIPPING INCLUDED

HTMD-RACK

- Store and move up to 4 dollies
- Shipping weight: 21 LBS.

17 Gallon Low Profile Oil Drain



Manual Pump
IN STORE PICK-UP PRICE
\$169

HTC70L-1

FEATURES

- Capacity: 17 Gallons
- Low profile design
- Durable lightweight polypropylene construction
- 4" Heavy-Duty swivel casters
- Ideal for draining oil or antifreeze
- T-Handle easily folds for storage
- Built-In manual pump for fast fluid draining
- Top wire mesh drain reduces splashing
- Shipping Weight: 50 lbs.

17 Gallon Low Profile Oil Drain



12V Pump
IN STORE PICK-UP PRICE
\$239

HTC70L-2

FEATURES

- Capacity: 17 Gallons
- Low profile design
- Ideal for draining oil or antifreeze
- T-Handle easily folds for storage
- Built-In 12V pump for fast fluid draining
- Durable lightweight polypropylene construction
- 4" Heavy-Duty swivel casters
- Top wire mesh drain reduces splashing
- Shipping Weight: 50 lbs.

20 Gallon Low Profile Oil Drain

This Atlas Low Profile metal oil drain is perfect for rolling under trucks and buses to change oil and other fluids. This Low Profile roll around oil drain has less than 8 inch ground clearance. With the long "T" handle and swivel casters the oil drain is easily maneuvered into position.

FEATURES

- Capacity: 20 Gallons
- Reservoir: 2' 8 1/2" Long X 2' 1" Wide X 6" Deep
- 25 1/2" Long T Bar Handle
- Internal Baffles Prevent Spills
- Shipping Weight: 98 Lb.

IN STORE PICK-UP PRICE
\$280
OR
\$430
W/ SHIPPING INCLUDED



HTOD-RU

8 Gallon Oil Drain

IN STORE PICK-UP PRICE
\$45
OR
\$60
W/ SHIPPING INCLUDED

HTA30L

Shipping Weight: 15 lbs.



Adjustable From
29 1/2" to 55"

FEATURES

- Four swivel casters make it portable and easy to maneuver
- Oil drain valve makes disposal easy
- 17" funnel diameter
- Lightweight Plastic

18 Gallon Oil Drain



IN STORE PICK-UP PRICE
\$80
OR
\$100
W/ SHIPPING INCLUDED

HTB75L

Shipping Weight: 20 lbs.

Adjustable From
36" to 72"

4 Gallon Oil Drain Pan



HTOP15

IN STORE PICK-UP PRICE
\$10
OR
\$25
W/ SHIPPING INCLUDED

- Plastic
- 4 Gallon (15L) Oil Drain Pan
- Shipping Weight: 5 Lb.

26 Gallon Oil Drain

To evacuate the oil from the container, simply hook an air line to the unit, turn the valve, and the oil is forced out through the evacuation tube.

PRESSURIZED

IN STORE PICK-UP PRICE
\$199

Lightweight Plastic

FEATURES

- Heavy duty plastic construction
- 26 gallon capacity
- Pressurized evacuation
- Pressurized gauge
- Shipping weight 75 lb.



HTE100L-1

18 Gallon Oil Extractor

This Atlas 18 gallon capacity Oil Extractor and Oil Drain is perfect for any commercial or home shop. This oil drain/extractor features both a standard funnel to catch drained oil from overhead as well as a vacuum system to suck oil out of an engine.

HTOD18-EX

PRESSURIZED

IN STORE PICK-UP PRICE
\$270
OR
\$348
W/ SHIPPING INCLUDED

FEATURES

- Steel
- Dolly handle
- Measuring tank
- 3" Solid rubber rear swivel casters
- 5" Solid rubber front wheels
- 3 probe adapters - 2 plastic, 1/4" and 5/16" diameter, 1 copper, 1/4" diameter



18 Gallon Steel Oil Drain

To evacuate the oil from the container, simply hook an air line to the unit, turn the valve, and the oil is forced out through the evacuation tube.



IN STORE PICK-UP PRICE
\$140
OR
\$196
W/ SHIPPING INCLUDED

HTOD18

FEATURES

- Pressurized oil drain allows oil to be removed in seconds
- 15" funnel diameter
- Adjustable from 46" to 76"
- Shipping Weight: 56 lb.

PRESSURIZED

30 Gallon Steel Oil Drain

To evacuate the oil from the container, simply hook an air line to the unit, turn the valve, and the oil is forced out through the evacuation tube.

IN STORE PICK-UP PRICE
\$249
OR
\$399
W/ SHIPPING INCLUDED

HTOD30

FEATURES

- 30 gallon capacity
- Adjustable Height from 49 3/4" - 73 1/2"
- Pressurized oil drain allows oil to be removed in seconds
- Two front swivel casters make it portable and easy to maneuver
- 15 1/2" funnel diameter
- Shipping Weight: 80 lb.

PRESSURIZED



Over Engine Creeper / Topsider



EXTEND YOUR REACH!

Adjustable Height:
47 1/2" - 58 1/2"

IN STORE PICK-UP PRICE
\$170
OR
\$320
W/ SHIPPING INCLUDED

HTCREEPER-TS



Perfect For Working On Truck Engines

FEATURES

- Adjustable height: 47 1/2" - 58 1/2"
- Heavy duty casters
- Convenient tool drawer
- Deck is padded and covered with heavy duty vinyl for comfort

HT53002/HT56002

3 Ton/6 Ton/(Set of 2)

3 Ton
IN STORE PICK-UP PRICE

\$20
OR
\$43

W/ SHIPPING INCLUDED
Pair
HT53002

- Adjustable from 11" to 16 1/2"
- Shipping Weight: 23 lbs.



6 Ton
IN STORE PICK-UP PRICE

\$40
OR
\$78

W/ SHIPPING INCLUDED
Pair
HT56002

- Adjustable from 16" to 24"
- Shipping Weight: 38 lbs.

HT52008 LOW

2 Ton Low Tripod Stand

The 2 ton low tripod stand is the perfect choice for the mechanic who is working on a vehicle that is lifted by a two post lift or a four post lift. The adjustable 2 ton low tripod stand is used to offer additional support to either the front or the rear of the vehicle.

IN STORE PICK-UP PRICE

\$50
OR
\$76

W/ SHIPPING INCLUDED

Each
HT52008

Max Height: 53"
Min Height: 30"
Shipping Weight: 26 lbs



HT510001 & HT510003

IN STORE PICK-UP PRICE

\$115
OR
\$265

W/ SHIPPING INCLUDED

10 Ton
SHORT
(Set of 2)
Pair
HT510001



IN STORE PICK-UP PRICE

\$145
OR
\$295

W/ SHIPPING INCLUDED

10 Ton
TALL
(Set of 2)
Pair
HT510003



HT57501/HT512001

Deluxe 6 Ton/12 Ton

These deluxe trailer or truck jack stands work great with a variety of vehicles because it features adjustable height and three different contact adapters. These jack stands also features three spring loaded swivel casters, making it easy to move but stable when weight is applied on top.

Swivel Casters



6 Ton
IN STORE PICK-UP PRICE

\$330
OR
\$480

W/ SHIPPING INCLUDED

Each
HT57501
Shipping Weight: 160 lbs.



12 Ton
IN STORE PICK-UP PRICE

\$410
OR
\$560

W/ SHIPPING INCLUDED

Each
HT512001
Shipping Weight: 190 lbs.

HT58001 HIGH

2 Ton Heavy Duty Tripod Stand

The 2 ton heavy duty tripod stand is the perfect choice for the mechanic who is working on a vehicle that is lifted by a two post lift or a four post lift. The adjustable 2 ton heavy duty tripod stand is used to offer additional support to either the front or the rear of the vehicle. These jack stands can be placed between the runways of a four post lift and when the runways of the four post lift are lowered, the jack stands will support the weight of the vehicle. The wheels will be above the runway of the four post lift and wheel service can be easily performed.

- Minimum height: 48 1/2"
- Maximum height: 84"
- Shipping Weight: 39 lbs.

Max Height: 84"

IN STORE PICK-UP PRICE

\$65
OR
\$104

W/ SHIPPING INCLUDED

Each
HT58001



HT58005 & HT58003

With & Without Foot Pedal

Foot pedal "jounces" the saddle to help line up bolt holes.

The 1,500 LB. Tall Jack Stand with foot pedal is used with four post lifts, and two post lifts. This Atlas jack stand supports up to 1,500 pounds. The jack stand can easily be placed into position under the lifting points of cars or trucks.

- Minimum height - 54"
- Maximum height - 80"
- Shipping Weight: 40 lbs.

Without
Foot Pedal
IN STORE PICK-UP PRICE

\$55
OR
\$89

W/ SHIPPING INCLUDED

Each
HT58003



With
Foot Pedal
IN STORE PICK-UP PRICE

\$55
OR
\$94

W/ SHIPPING INCLUDED

Each
HT58005

4 Ton Porta Power Kit

IN STORE PICK-UP PRICE

\$110
OR
\$155

W/ SHIPPING INCLUDED

HT0102



FEATURES

- 4 ton Hydraulic Pump and Ram w/ female coupler
- 5' hydraulic hose
- 5 extension tubes: 3", 5", 8 1/2", 16 1/2", & 19 1/4"
- 1/2 ton capacity Spreader
- Flat base
- Ram toe
- Plunger toe
- Wedge head
- 90° V-base
- Male connector
- Serrated Saddle
- Rubber Head
- Storage case

10 Ton Porta Power Kit

IN STORE PICK-UP PRICE

\$155
OR
\$200

W/ SHIPPING INCLUDED

HT0202



FEATURES

- 10 ton Hydraulic Pump and Ram w/ female coupler
- 5' hydraulic hose
- 4 extension tubes: 4 1/4", 10 1/4", 14 1/4", & 20 1/4"
- Flat base
- Ram toe
- Plunger toe
- Wedge head
- 90° V-base
- Male connector
- Serrated Saddle
- Rubber Head
- 1/2 ton capacity Spreader
- Storage case

Pallet Jacks

FEATURES

- Maximum Height 7 1/2"
- Minimum Height 3"
- Overall Width: 27"
- Length of Forks 47 1/2"
- Width of Forks 6 1/4"
- Distance Between Forks: 14 1/4"



Easily Transport Heavy Engines, Transmissions, Or Any Other Large Piece Of Automotive Parts From Bay To Bay In Your Service Shop



*Color May Vary

4,400 lb. Capacity

IN STORE PICK-UP PRICE

\$305
OR
\$455

W/ SHIPPING INCLUDED

HTPJ20
Shipping Weight: 175 lbs.

5,500 lb. Capacity

IN STORE PICK-UP PRICE

\$310
OR
\$460

W/ SHIPPING INCLUDED

HTPJ25
Shipping Weight: 270 lbs.

6,600 lb. Capacity

IN STORE PICK-UP PRICE

\$315
OR
\$465

W/ SHIPPING INCLUDED

HTPJ30
Shipping Weight: 300 lbs.

20 Ton Porta Power Kit

IN STORE PICK-UP PRICE

\$355
OR
\$505

W/ SHIPPING INCLUDED

HT0204



FEATURES

- 20 ton Hydraulic Pump and Ram
- 5' hydraulic hose
- 4 connective tubes: 5", 10", 20", & 27"
- 3 each, 3" connective tube & 2 1/2" joint connector tube
- Base
- Ram toe
- Plunger toe
- Wedge toe
- V-base
- Metal Storage Cases
- Collapsed Height: 11 1/8"
- Extended Height: 16"

Perfect For Frame And Body Repair

Sandblast Cabinets

Sandblast Cabinets allow you to remove scale or heavy rust from automotive parts, clean up rusty tools, etch glass, and many other special applications.

SBC90 HTSBC90

IN STORE PICK-UP PRICE
\$115
 OR
\$155
 W/ SHIPPING INCLUDED

FEATURES

- Easy operation
- Interior dust filter
- Continually recycles
- Low air supply design
- Interior fluorescent light
- 17" Gauntlet Gloves



Convenient Table-Top Model

SBC220 HTSBC220

IN STORE PICK-UP PRICE
\$330
 OR
\$480
 W/ SHIPPING INCLUDED



Side Loading

SBC350

The SBC350 sandblast cabinet features switches for power, light and dust collector, a regulator and pressure gauge, and indicator lights. The unit comes with 2 blasting nozzles: a heavy-duty gun with valve, and a stationary nozzle that is controlled with the foot switch. Two large side doors make loading and unloading simple.

HTSBC350-KIT



110V

IN STORE PICK-UP PRICE
\$695
 OR
\$845
 W/ SHIPPING INCLUDED

- Interior dust filter
- Large side load doors
- Interior fluorescent light
- 37 1/8" W x 23 5/8" D
- 22 1/2" H work volume

Includes Free 50 lb. Bag Of Glass Beads

SBC420

The SBC 420 Sandblast Cabinet has an attached vacuum system. The SBC420 allows you to load parts from both the side and top of the cabinet.

HTSBC420-KIT



110V

IN STORE PICK-UP PRICE
\$950
 OR
\$1100
 W/ SHIPPING INCLUDED

FEATURES

- Easy operation
- Continually recycles
- Bottom feed system
- Heavy-duty blast gun
- 4 Ceramic nozzles
- Abrasive flexibility
- 24" Gauntlet gloves
- 2 side doors as well as top load door
- Built-in fluorescent lamp
- Self-contained dust collection system with cartridge filter

Includes Free 50 lb. Bag Of Glass Beads



SBC990

The SBC 990 Sandblast Cabinet has an attached vacuum system and allows you to load large parts through it's large folding front door.

IN STORE PICK-UP PRICE
\$1395
 OR
\$1545
 W/ SHIPPING INCLUDED

FEATURES

- Large folding front door
- Easy operation
- Continually recycles
- Abrasive flexibility
- NE490 Power gun with foot pedal
- 4 Ceramic nozzles
- 110 Volt
- 24" Gauntlet gloves
- Built-in fluorescent lamp
- Shipping Weight: 490 lb.



HTSBC990-KIT

Includes Free 50 lb. Bag Of Glass Beads



PSBC990

Pressurized Model Of The SBC990

IN STORE PICK-UP PRICE
\$1995
 OR
\$2145
 W/ SHIPPING INCLUDED

HTPSBC990-KIT

WATCH OUR VIDEO ONLINE



SBC1200

HTSBC1200-KIT

The extra wide SBC1200 sandblast cabinet features two large folding doors (one in the front and one in the back) for easy loading and unloading of large parts. The SBC1200 has two foot-operated blasting guns located on each side of the blast cabinet allowing two people to operate the access ports at the same time.

110V

PRICES SUBJECT TO CHANGE VISIT OUR WEBSITE FOR CURRENT PRICING AND SPECIALS



IN STORE PICK-UP PRICE
\$2399
 OR
\$2549
 W/ SHIPPING INCLUDED

FEATURES

- Easy operation
- Two blasting guns
- 2 Ceramic tip sizes
- 24" Gauntlet gloves
- Two large folding doors
- Overall size: 60" Wide x 55" Deep x 72 1/2" High
- Work Volume: 47" Wide x 51" Deep x 33 1/2" High
- Built-in fluorescent lamp

Includes Free 100 lb. Bag Of Glass Beads

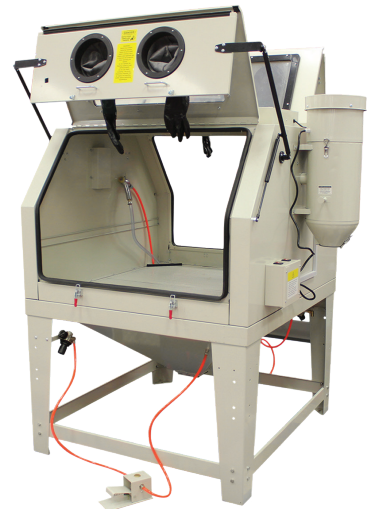

HTRA20

20 Gallon Roll About Sandblast Unit

FEATURES

- Easy operation
- Abrasive flexibility
- Portable
- 110V Power
- Heavy duty 3/8" hose
- 6" solid tires
- Tilt-and-go handle for increased mobility
- Concave head for ease of filling
- Carbon steel abrasive mixing valve for durability and long life
- Shipping Weight: 60 lbs.

IN STORE PICK-UP PRICE
\$155
 OR
\$215
 W/ SHIPPING INCLUDED



HTRA20

HTSB28

28 Gallon Roll Around Sandblast Unit With Vacuum

FEATURES

- Easy operation
- Abrasive flexibility
- Portable
- 110V Power
- 110V Vacuum
- Heavy duty hose
- 6" solid tires
- Concave head for ease of filling
- Carbon steel abrasive mixing valve for durability and long life
- Shipping Weight: 90 lbs.

IN STORE PICK-UP PRICE
\$280
 OR
\$430
 W/ SHIPPING INCLUDED

Visit Our Website FOR MORE Product Photos AND DETAILED SPECIFICATIONS



HTSB28

HTMB275 Passenger and Light Truck

The HTMB275 tire spreader can be used with most wheel clamp tire changers. The metal mounting plate is held securely between the clamping jaws of the tire changer, allowing the operator to position the tire at the correct working height to make tire repair easy. The HTMB275 has adjustable spreader arms that fit on the inside beads of the tire and are spread open by use of the heavy metal arm. The 275 tire spreader is the perfect choice for those customers who need to perform inside tire repairs on most passenger and light truck tires. This tire spreader can be bolted to a workbench.

IN STORE PICK-UP PRICE
\$90
OR
\$115
W/ SHIPPING INCLUDED

Specifications

Tire Width Capacity: 5 3/4" TO 10 3/4"
Overall Dimensions: 35" L x 12" W x 10 1/2" H
Shipping Weight: 25 Lb.



HTM275 Passenger and Light Truck

The HTM275 tire spreader is a heavy duty tire spreader designed for use in shops that repair passenger and light truck tires. The HTM275 has an adjustable four (4) position table that can be rotated for easy access to the inside of the tire. The foot pedal controls the position of the table top. Depressing the spring actuated foot pedal allows operator to move the table top to the most desired position. The tire is rotated easily on the heavy rollers mounted on the table top. The spreader arms are adjustable to accommodate passenger and light truck tires.

IN STORE PICK-UP PRICE
\$115
OR
\$222
W/ SHIPPING INCLUDED

Specifications

Tire Width Capacity: 5 3/4" TO 10 3/4"
Tire Diameter Capacity: 11" TO 24"
Overall Dimensions: 30" L x 12" W x 39 3/4" H
Shipping Weight: 67 Lb.

FEATURES

- Portable
- Adjustable clamping arms
- 4 position table tilt
- Rotatable table design
- Makes tire inspections and repair quick & easy
- Adapts to varying sidewall heights and tire widths



HTS275 Passenger and Light Truck

The HTM275 tire spreader is a heavy duty tire spreader designed for use in shops that repair passenger and light truck tires. The HTM275 has an adjustable four (4) position table that can be rotated for easy access to the inside of the tire. The foot pedal controls the position of the table top. Depressing the spring actuated foot pedal allows operator to move the table top to the most desired position. The tire is rotated easily on the heavy rollers mounted on the table top. The spreader arms are adjustable to accommodate passenger and light truck tires.

FEATURES

- Portable
- Adjustable clamping arms
- 4 position table tilt
- Rotatable table design
- Makes tire inspections and repair quick & easy
- Adapts to varying sidewall heights and tire widths

IN STORE PICK-UP PRICE
\$530
OR
\$680
W/ SHIPPING INCLUDED



Specifications

Tire Width Capacity: 5 3/4" TO 10 3/4"
Tire Diameter Capacity: 11" TO 24"
Overall Dimensions: 30" L x 12" W x 39 3/4" H
Shipping Weight: 67 Lb.

HTS825 Large Truck

The HTS825 truck tire spreader makes it easy to lift and repair large truck tires. The powerful pneumatic lifting table can accommodate tires of up to 250 lbs. and raises them to the perfect inspection and working height. The adjustable clamping arms and rollers as well as the pneumatic lift table allow the operator to repair large and small truck tires (and passenger tires) easily. If you are a professional tire repair shop that handles all sizes of tires, then the HTS825 is the perfect choice for all your tire repair needs. The HTS825 tire spreader has an adjustable work light and a tool tray.

FEATURES

- Easy to use hand operated controls
- Adjustable clamping arms
- Pressure gauge & regulator assembly
- Tool Tray
- Adjustable light
- Air outlet for air tool connection



IN STORE PICK-UP PRICE
\$1145
OR
\$1295
W/ SHIPPING INCLUDED

Specifications

Tire Size Capability: 8.25-20; 14.00-20(9R-16.5R); 11-22.5R
Air Requirements: 110-145 PSI
Work Light: 110V
Overall Dimensions: 64" L x 28" W x 42" H
Shipping Weight: 450 Lb.

Strut Spring Compressor

This manually operated Strut Spring Compressor is designed to aid in replacing strut springs and strut assembly components. The Strut Spring Compressor is adjustable to handle a wide variety of strut spring sizes.

Commercial Grade

FEATURES

- Heavy duty capacity - handles the heaviest coil over shocks
- Handles extra long springs - room to disassemble long struts
- Gives easy strut access
- Independently adjustable upper and lower hooks

IN STORE PICK-UP PRICE
\$300
OR
\$450
W/ SHIPPING INCLUDED

HTT01-SC



Air Operated Strut Spring Compressor

This Air Operated Strut Spring Compressor is designed to aid in replacing strut springs and strut assembly components. The Strut Spring Compressor is adjustable to handle a wide variety of strut spring sizes.

Commercial Grade

FEATURES

- Fully Adjustable To Fit A Wide Variety Of Strut Springs
- Air Operated
- Heavy Duty
- Shipping Weight: 150 LBS.
- Shipping Dimensions: 55" x 23" x 12"

IN STORE PICK-UP PRICE
\$385
OR
\$535
W/ SHIPPING INCLUDED

HT1206



Freight Truck Shipping Information

Our larger products are shipped by a common freight carrier. You (the customer) will need to have the product delivered to place that a 53 foot semi trailer can easily access. You (the customer) will need to provide the correct equipment to unload your purchase. If you do not have a loading dock, then you will need a forklift, skid steer, or some similar type of material handling equipment to unload the product. We included representative pictures of some products packaged for freight shipment below.

IF YOU HAVE ANY FREIGHT QUESTIONS REGARDING YOUR PRODUCT, PLEASE GET THEM ASKED AND ANSWERED BEFORE WE SHIP!

For the majority of locations, we may be able to provide a semi truck with a lift gate. The lift gate will assist the customer in unloading products such as motorcycle lifts, tire changers, wheel balancers, air compressors, sandblast cabinets, etc. Unloading two post or four post lifts (and other products weighing over 1000 pounds) will require a forklift (or some type of material handling equipment), if the customer does not have a truck-height loading dock. Remember, the customer is always responsible for providing the necessary equipment to offload their product safely.

If a product is picked up at a local trucking terminal, the truck terminal staff should be able to load the equipment on your trailer or truck. (You must furnish a vehicle that is large enough to "handle" your product). If you need to locate a terminal in your area, or if you would like a shipping quote, please contact our office.

GREG SMITH EQUIPMENT DOES NOT OWN THE DELIVERY TRUCK LINE.



THE CUSTOMER IS ALWAYS RESPONSIBLE FOR UNLOADING THE PRODUCT FROM THE DELIVERY TRUCK.

VISIT OUR WEBSITE FOR MORE SHIPPING INFORMATION

Atlas Apex 8 - 4 Post Lift

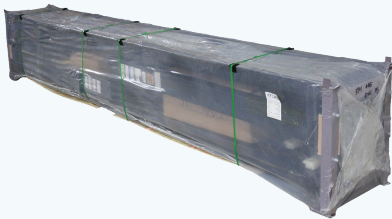

Shipping Weight: 1,800 lbs.

Atlas WB77 Wheel Balancer



Shipping Weight: 400 lbs.

Atlas EML-1200 Electric Motorcycle Lift



Shipping Weight: 800 lbs.

Atlas Apex 9BP - 2 Post Lift



Shipping Weight: 1,700 lbs.

In Store Pick Up Is Available

Visit any of our nine brick and mortar locations and pick up your purchase. Just make sure that you bring "enough vehicle" and call ahead to make sure that "your" location has the product in stock.

WE HAVE PACKAGE DIMENSIONS AND SHIPPING WEIGHTS ON OUR WEBSITE. CHECK TO MAKE SURE YOU BRING THE RIGHT VEHICLE OR TRAILER TO PICK UP YOUR EQUIPMENT.



NEED FINANCING? CALL US TODAY!

Our company has partnered with lending institutions to provide our customers with alternative financing options.



Are you a new or growing business???

Ask our finance department about our 100% commercial lease to own programs.

Benefits Include:

- Conserve cash
- Little to no money down
- Easier than bank financing
- End of term ownership or new equipment upgrade options
- 100% Tax Deductible off balance sheet lease options available

We ship all over the USA and the World, so call us for your best shipping price.

(800) 673-8740

VISIT ONE OF OUR



**BRICK AND MORTAR
LOCATIONS TODAY!**

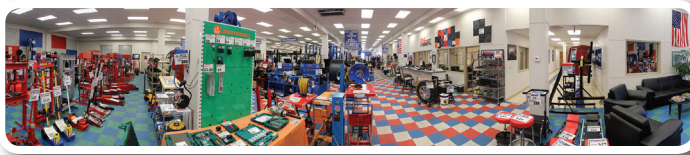
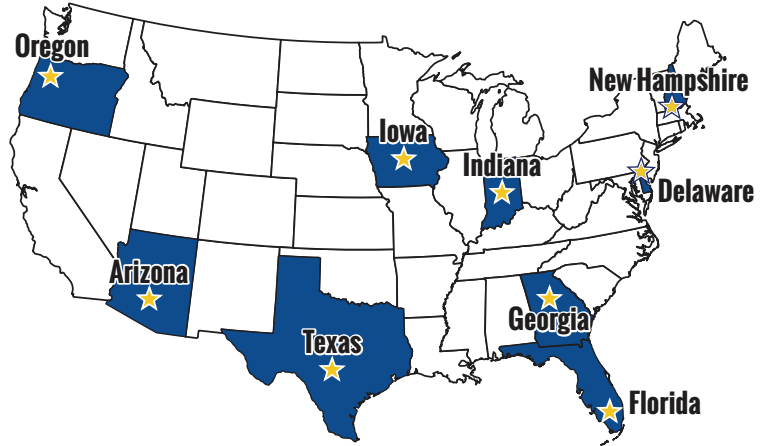

**PROUDLY SERVING YOU
WITH NINE LOCATIONS
NATIONWIDE!**

WE SHIP ANYWHERE!

www.GregSmithEquipment.com



5800 Massachusetts Ave.
Indianapolis, IN 46218
www.GregSmithEquipment.com

PRINTED IN THE USA

(800) 673-8740

VISIT ONE OF OUR BRICK AND MORTAR LOCATIONS TODAY!

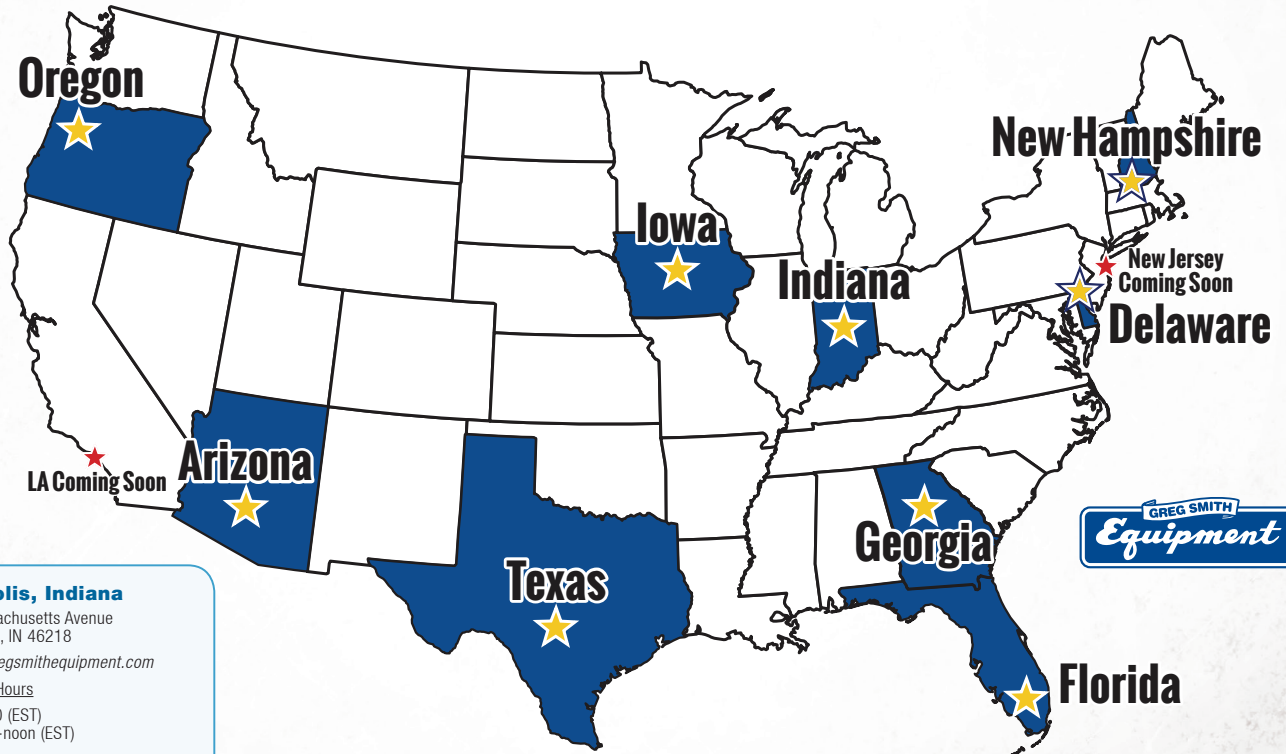

Indianapolis, Indiana

5800 Massachusetts Avenue
Indianapolis, IN 46218
salesIN@gregsmithequipment.com
Showroom Hours
M-F: 8-5:30 (EST)
Saturday: 8-noon (EST)

Newark, Delaware

250 Executive Drive, Suite 1
Newark, DE 19702
salesDE@gregsmithequipment.com
Showroom Hours
M-F: 8-5:30 (EST)
Saturday: 8-noon (EST)

Atlanta, Georgia

2375 Button Gwinnett Drive, Suite 100
Atlanta, GA 30340
salesGA@gregsmithequipment.com
Showroom Hours
M-F: 8-5:30 (EST)
Saturday: 8-noon (EST)

Tolleson, Arizona

8399 West Van Buren Street, Suite 210
Tolleson, AZ 85353
salesAZ@gregsmithequipment.com
Showroom Hours
M-F: 8-5:30 (MST)
Saturday: 8-noon (MST)

Austin, Texas

3206 Industrial Terrace Suite #102
Austin, TX 78758
salesTX@gregsmithequipment.com
Showroom Hours
M-F: 8-5:30 (CST)
Saturday: 8-noon (CST)

Miami, Florida

11801 NW 100th Rd., Suite 8
Medley, FL 33178
salesFL@gregsmithequipment.com
Showroom Hours
M-F: 8-5:30 (EST)
Saturday: By Appointment Only

Hudson, New Hampshire

8 Industrial Drive
Hudson, NH 03051
salesNH@gregsmithequipment.com
Showroom Hours
M-F: 8-4:30 (EST)
Saturday: 8-noon (EST)

Milwaukie, Oregon

5505 SE International Way, Suite D
Milwaukie, OR 97222
salesOR@gregsmithequipment.com
Showroom Hours
M-F: 8-5:30 (PST)
Saturday: By Appointment Only

Grimes, Iowa

3801 S. James Street, Suite 140
Grimes, IA 50111
salesIA@gregsmithequipment.com
Showroom Hours
M-F: 8-5:30 (CST)
Saturday: By Appointment Only