



Owner's Manual

Everything you need to know about Olli
V1.0 - 2020

Introduction

Congratulations and thank you for choosing Olli. We are pleased to welcome you to the growing number of organizations who use Olli. We are very proud of the advanced engineering, autonomy and high-quality construction of each Olli we create. This manual will introduce you to Olli's features, safety, infrastructure needs, maintenance and other useful information. To become familiar with your new Olli and fully enjoy the experience, please read carefully.

Olli will need an Onboard Steward when driving in manual mode and for regular maintenance. The Onboard Steward will be provided to you either by LMI or an approved channel partner/fleet operator

organization. Any service related activities must be performed only by the service team from LMI or from an approved organization.

All information in this manual is current at the time of publication. However, LMI reserves the right to make changes at any time so that our policy of continual product improvement may be carried out.

For any questions about the operation, maintenance, service or other topics not covered in this manual, please contact Local Motors Service Department at **1.888.256.2028**.



Important Labels

Information in this document considered of importance is distinguished by the following icons and notations. Please be familiar with these icons as they will appear throughout.



Electric Shock

This symbol indicates a hazardous situation which, if not avoided, could result in death or serious injury due to electricity.



Warning

This symbol indicates a hazardous situation which, if not avoided, could result in death or serious injury to people.



Caution

This symbol indicates a hazardous situation which, if not avoided, could result in minor or moderate injury to people.



Notice

This symbol indicates a situation which, if not avoided, could result in vehicle damage.

Contents

1.0 Vehicle Overview

Pg. 08-09 | About Olli
Pg. 10-15 | Vehicle Features
Pg. 16-17 | Operator Controls
Pg. 18-19 | Vehicle Technical Specifications

2.0 Recognizing Olli

Pg. 22-23

5.0 Safety

Pg. 26-27 | Safety Systems
Pg. 28-29 | Egress Procedure
Pg. 30-31 | Electrical Safety
Pg. 32-35 | Hazardous Materials

3.0 Infrastructure

Pg. 38-39 | Garage Requirements
Pg. 40-41 | RTK Base Station
Pg. 42 | Internet Requirements
Pg. 42 | Laptop & Cables
Pg. 43 | Power & Charging Requirements

4.0 General Maintenance

Pg. 46 | Charging Olli
Pg. 47-48 | Cleaning Olli
Pg. 49 | Tire Maintenance
Pg. 50-51 | Towing

6.0 Information Technology

Pg. 54-55 | GDPR Requirements
Pg. 56-57 | Cybersecurity Information

7.0 Shipping Procedures

Pg. 60-61 | Shipping Procedures
Pg. 61 | Vehicle Lift Points

8.0 Wrapping Olli

Pg. 64-65

9.0 Warranty

Pg. 68-69

10.0 Additional Notes

Pg. 72-78

Vehicle Overview



About Olli

Meet Olli, your friendly neighborhood mobility solution and the world's first co-created, self-driving, electric and cognitive shuttle. Olli is ready to change the way we view transportation. From neighborhoods to campuses to urban city centers, learn how Olli is the smart, safe, sustainable option for getting around.

Olli is a low speed electric powered passenger carrier vehicle designed for use in light occupancy transit. Olli can transport one Onboard Steward and up to eight

seated occupants. Olli has an air ride automatic leveling suspension system to adjust ride height and provide smooth performance.

Each Olli shuttle has an electronically activated door, eight passenger seats with seatbelts and cabin climate control. Olli is a drive-by-wire system using electronic servo motors to actuate steering and braking controls via joystick input command.



Vehicle Features

Interior

- 01 Audio Speakers
- 02 Grab Handles
- 03 Seatbelts with Retractors
- 04 Forward-Facing Rear Passenger Seating
- 05 Rear-Facing Front Passenger Seating
- 06 Information Display Screens
- 07 Emergency Window Breaker
- 08 Side-Facing Seating
- 09 Emergency Stop Button
- 10 Olli Control Center

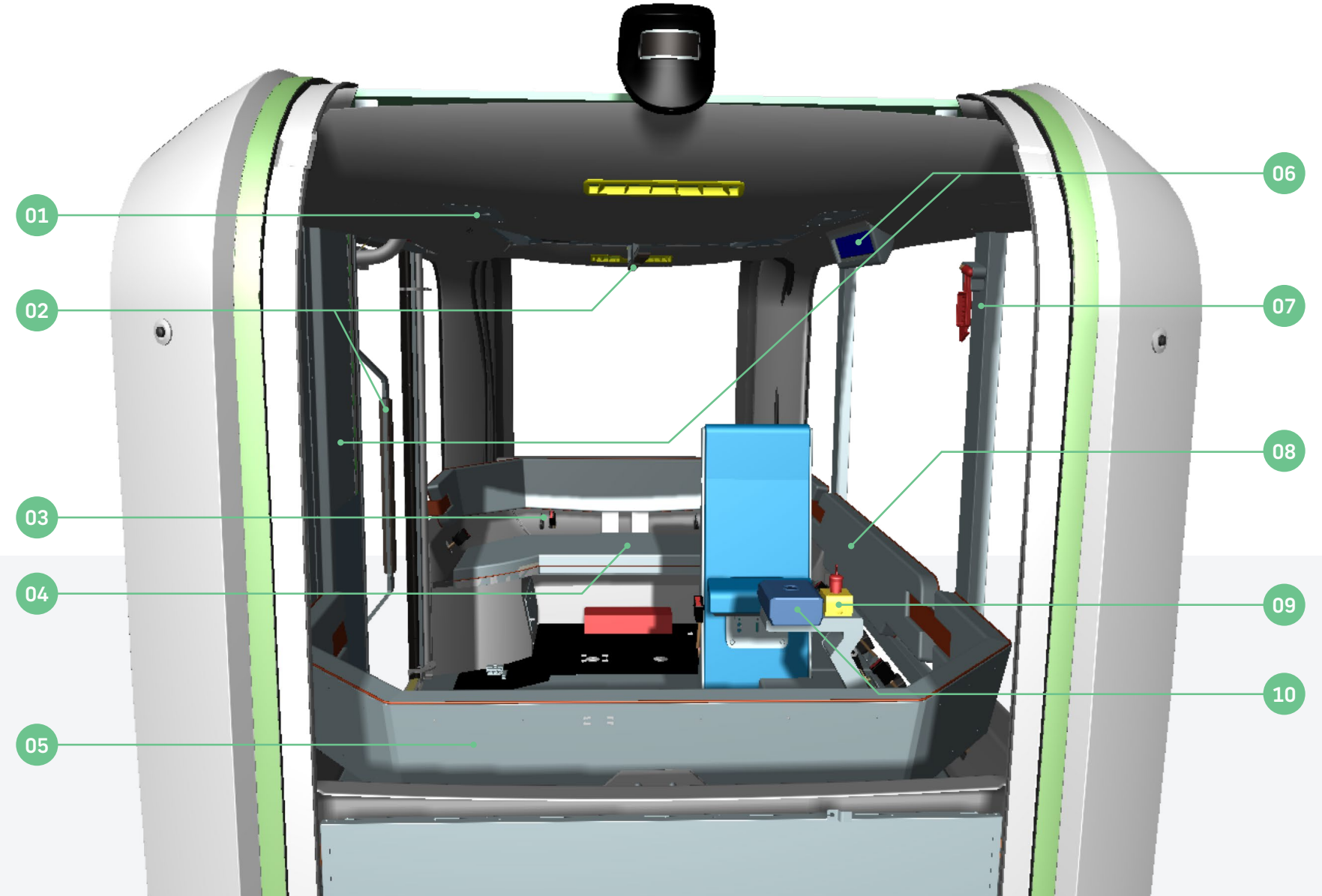

Exterior, Front

- 01 Front Right Camera
- 02 Front Windscreen
- 03 Front Light Blades
- 04 Headlights
- 05 Front Lower LiDAR
- 06 GPS (Hidden)
- 07 Front Upper LiDAR
- 08 Front Left Camera
- 09 Front Information Display Screen
- 10 Front Lower Camera
- 11 Front Radar
- 12 Front Tow Hook

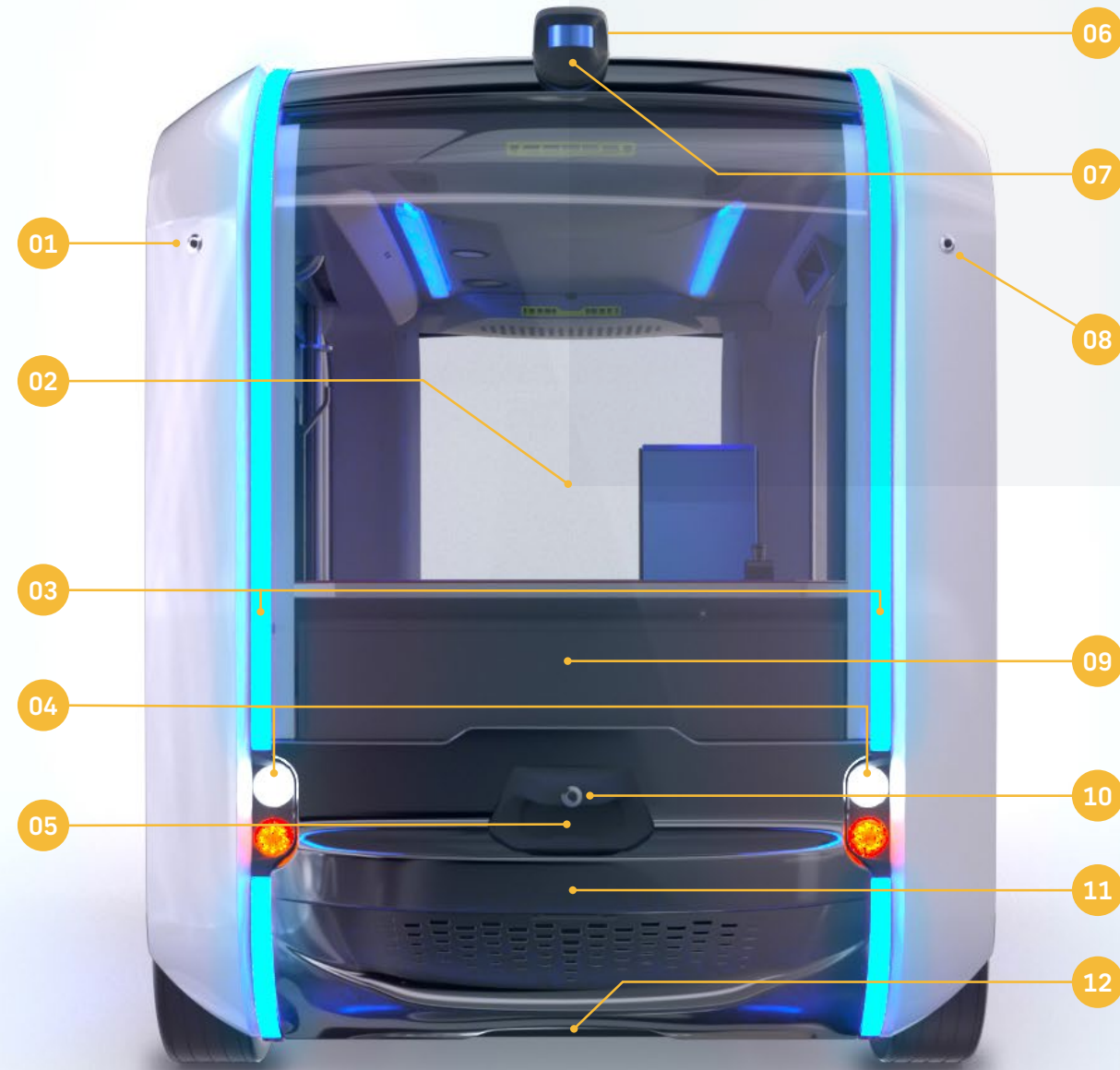

Exterior, Rear

- 01 GPS (Hidden)
- 02 Rear Upper Camera
- 03 Rear Light Blades
- 04 Rear Information Display Screen
- 05 Taillights
- 06 Rear Lower Camera
- 07 Rear LiDAR
- 08 Rear Radar
- 09 Rear Tow Hook

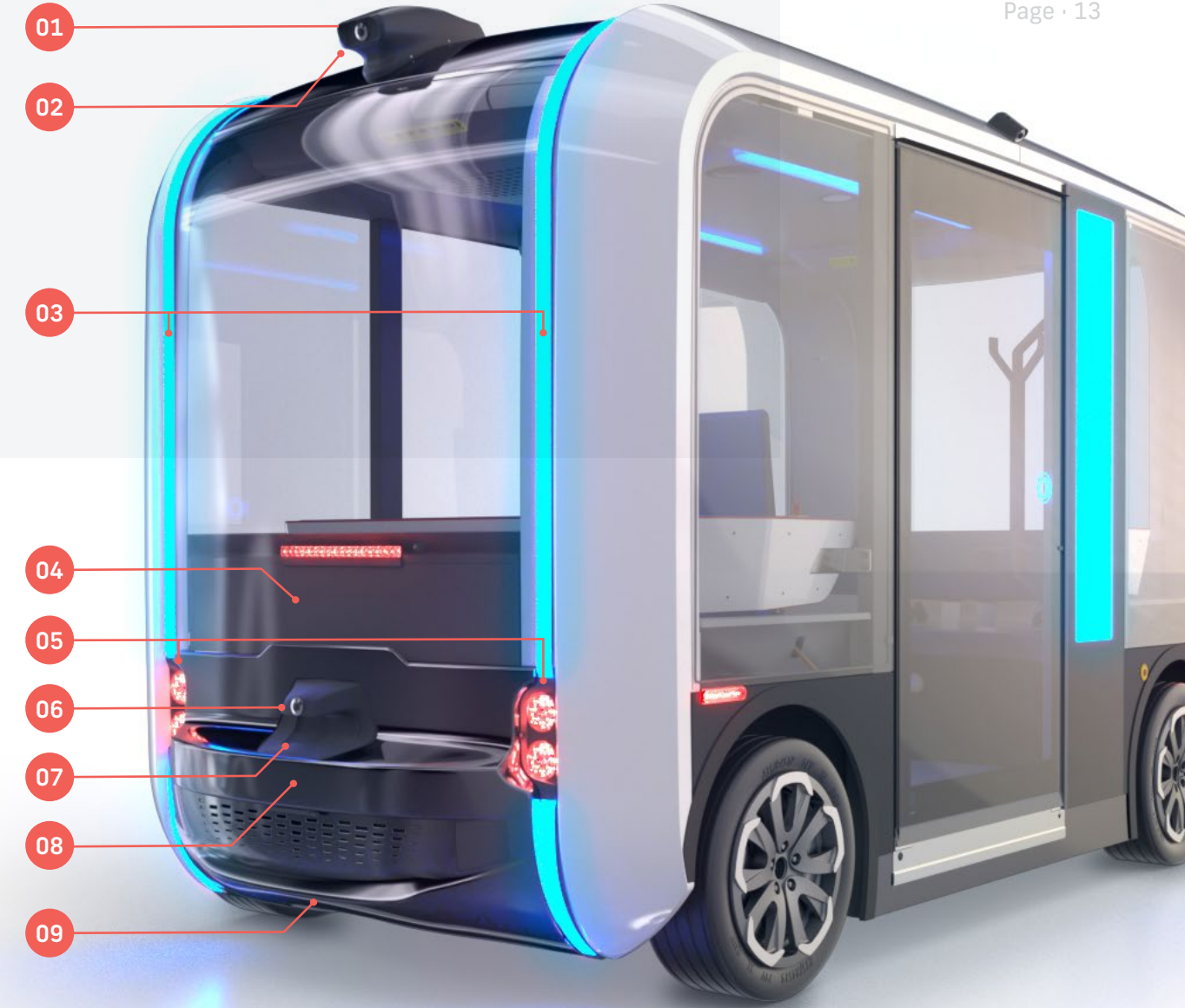

Exterior, Right

- 01 Front Right Window Pane
- 02 Side Information Display Screen
- 03 Right Camera
- 04 Rear Right Window Pane
- 05 Door Entry Button (Captron)
- 06 Vehicle Identification Plate
- 07 Rear Right LiDAR
- 08 Rear Right Reflector
- 09 Wheelchair Ramp
- 10 Entry Door
- 11 Emergency Door Release Button
- 12 Front Right LiDAR
- 13 Front Right Radar
- 14 Front Right Reflector

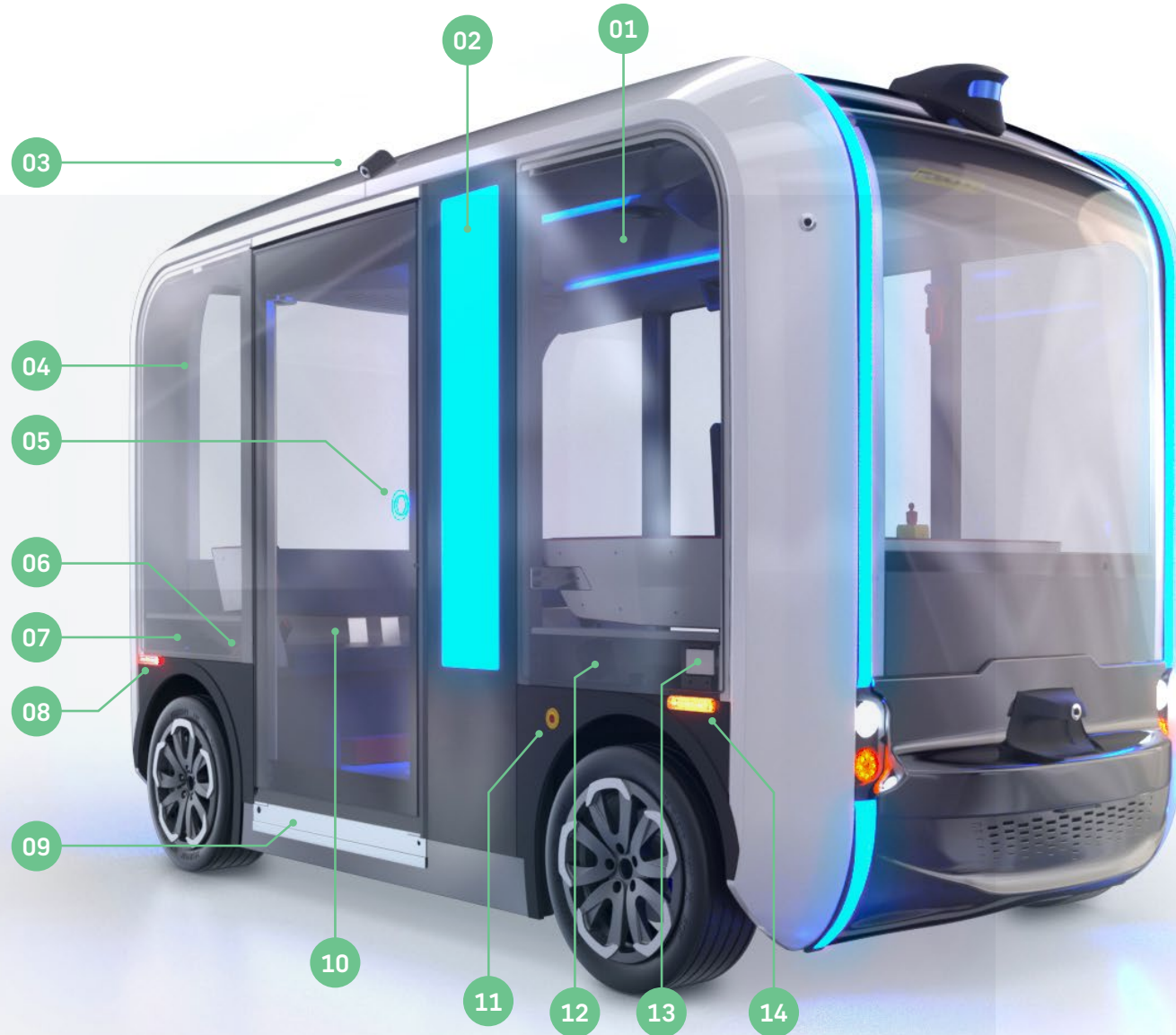

Exterior, Left

- 01 Rear Left Window Pane
- 02 Left Camera
- 03 Front Left Window Pane
- 04 Left Center Window Pane
- 05 Front Left Radar
- 06 Front Left Reflector
- 07 Front Left LiDAR
- 08 Left Bottom Window Pane
- 09 Rear Left LiDAR
- 10 Rear Left Reflector

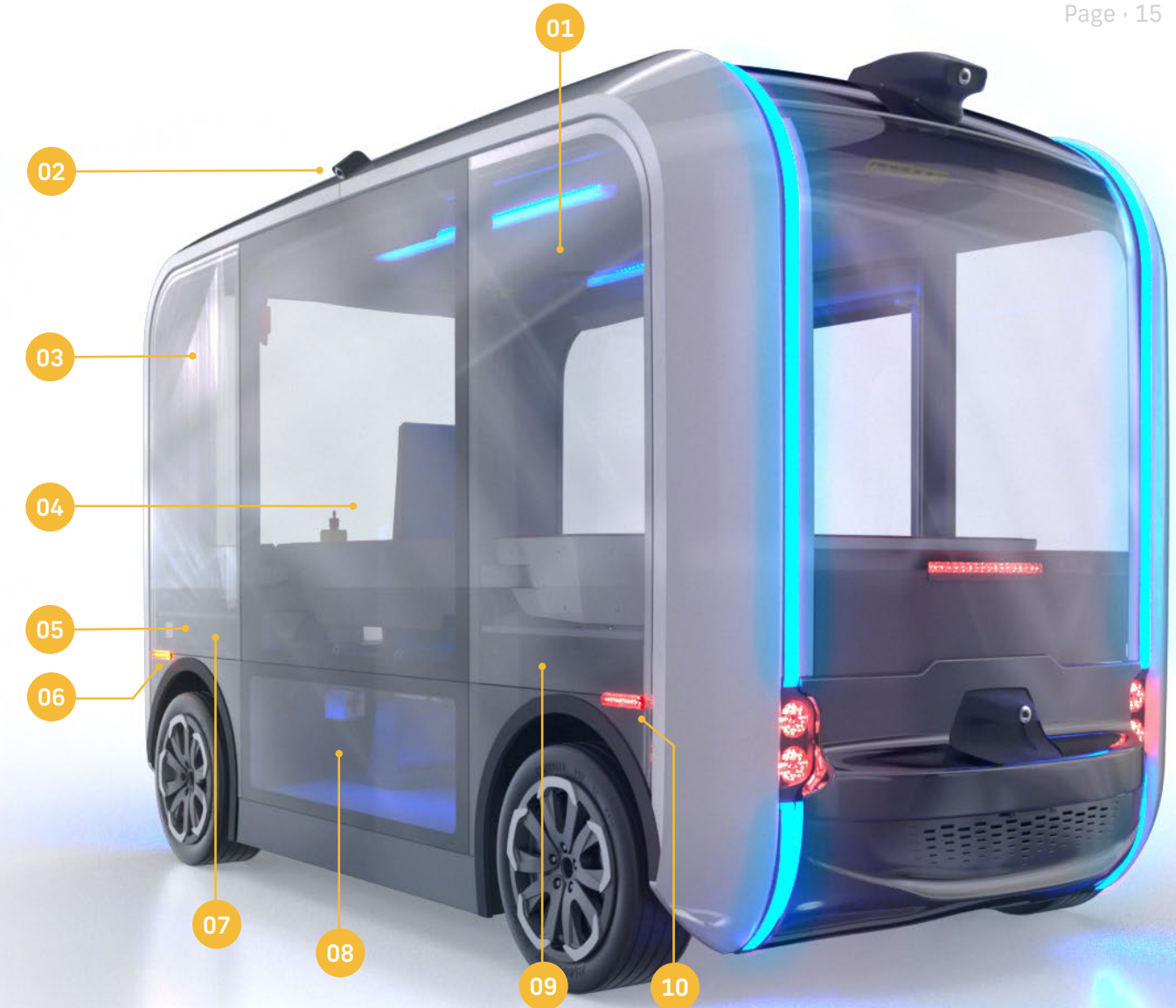

Operator Controls

NOTICE

Do not attempt servicing any component of Olli without consulting Local Motors Service Department. Servicing Olli without Local Motors' approval may void the warranty and may be subject to legal consequences.

WARNING

Do not attempt to start and/or drive Olli if you are not a certified Onboard Steward. Operating Olli without Local Motors' approval may void the warranty and may be subject to legal consequences.

For safety reasons, we only authorize certified Onboard Stewards to do the following operations.

- Use Olli's control center
- Switch on/off procedures
- Drive in manual/autonomous mode
- Park Olli in the garage
- Remove any components from Olli
- Use the laptop provided by Local Motors in the garage
- Other activities related to operating Olli

Detailed instructions on how to operate Olli are covered in the Operator's Manual. The Operator's Manual is provided to certified Onboard Stewards, channel partners, and fleet operating agencies.

Any identified service related issues must be reported to Local Motors Service Department at [1.888.256.2028](tel:1.888.256.2028).

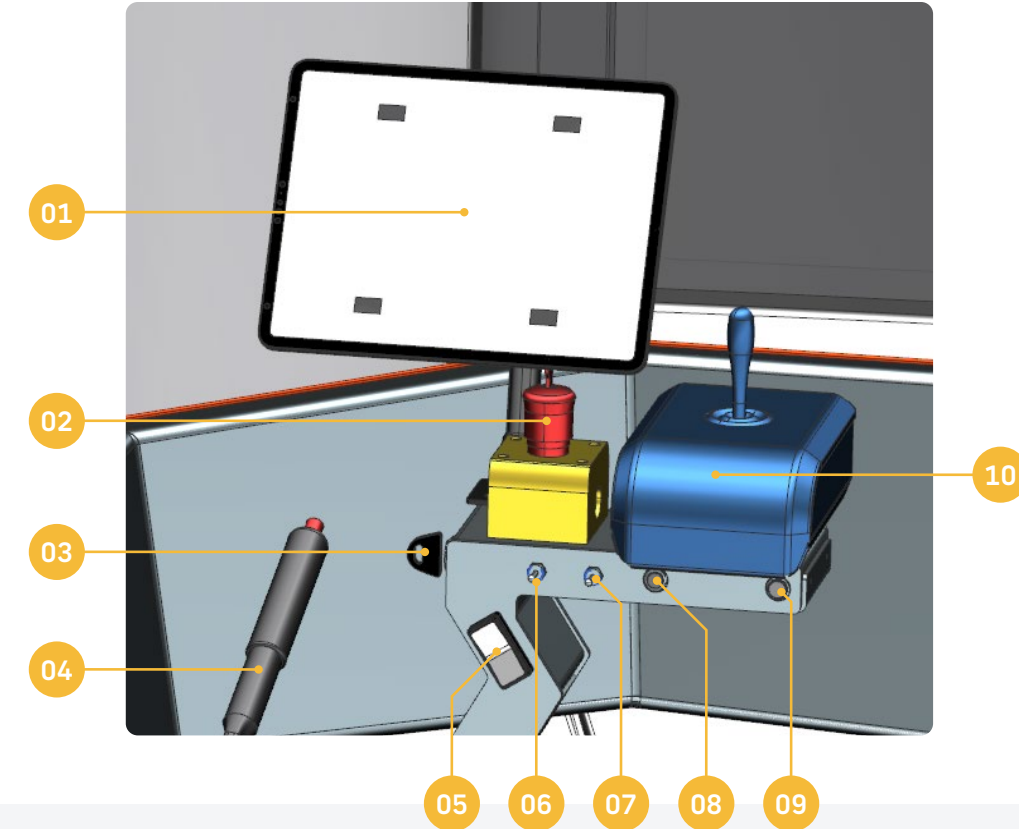

Olli Control Center

- 01 Steward Display Screen
- 02 Emergency Stop Button
- 03 Ignition Switch
- 04 Hand Brake

- 05 Air Ride Automatic Control
- 06 Autonomous/Manual Mode Switch
- 07 Forward/Reverse Switch
- 08 Autonomous Engagement Button

- 09 Autonomous Disengagement Button
- 10 Driver Controls

Vehicle Technical Specifications

Exterior Dimensions

A Overall Length	162.8 in (4136 mm)
B Overall Width	79.6 in (2022 mm)
C Overall Height	102.7 in (2610 mm)
D Wheel Base	101 in (2567.7 mm)
E Ground Clearance	4.8 in (122 mm)
F Ride Kneeling	+/- 2.65 in (67.5 mm)
G Overhang, Front	30.8 in (783.3 mm)
H Overhang, Rear	31 in (787.4 mm)
I Track, Front & Rear	70.9 in (1800 mm)

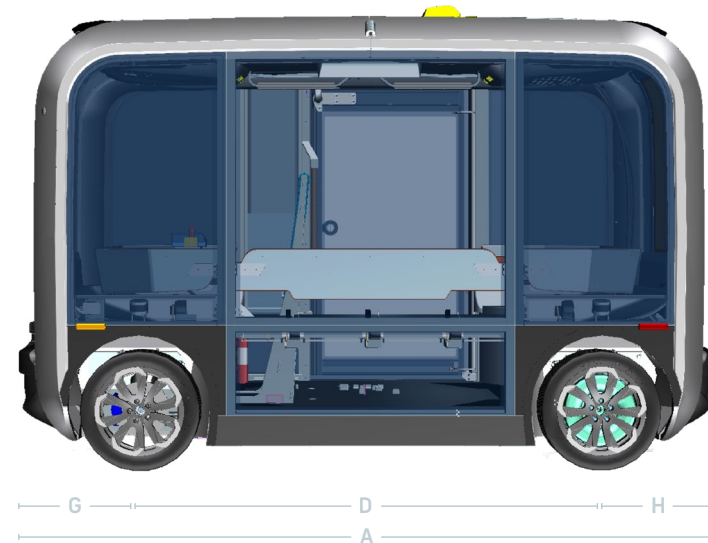

Weight

Curb Weight	4900 lbs (2222 kg)
Max Load	1600 lbs (726 kg)
Max Gross Weight	6500 lbs (2948 kg)

Motors

Model	Rear Wheel Hub Motor x 2
Peak Power	215 hp (160 kW)
Continuous Power	163 hp (120kW)
Max Speed	25 mph (40 kph)
Motor Weight	79 lb (36 kg)
Peak Torque	1844 ft-lb (2500 Nm)

Brakes

Front	4-Piston Disk Brake
Rear	Single Piston Disk Brake Integrated Parking Brake

Battery

12V Battery Type	Lead Acid
EV Battery Type	Li-ion
EV Battery Nominal Energy	18.5 kWh
EV Battery Voltage Range	300-400V
Vehicle Operating Temperature Range	32°F/0°C to 115°F/ 46°C

Recognizing Olli



Recognizing Olli

The photos in this document as well as the following listed identification markers will help identify Olli among other on-road vehicles.

Recognition Markers

- 01** Hoop shaped A-pillars on the corners
- 02** Large curved glass pane on the front and rear
- 03** Door located on right hand side
- 04** Large vertical display screen near the door
- 05** Horizontal front and rear fascia display screens
- ★ Olli is visually front and rear symmetrical, with only slight differences in her lights, LiDAR and radar placement



Safety



Safety Systems

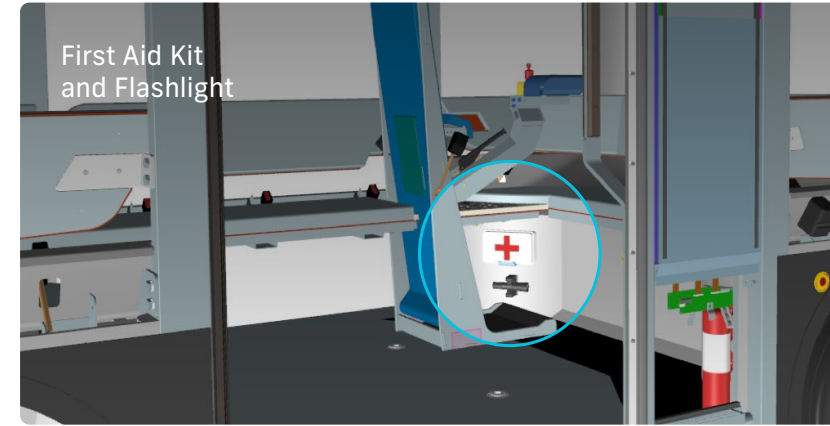
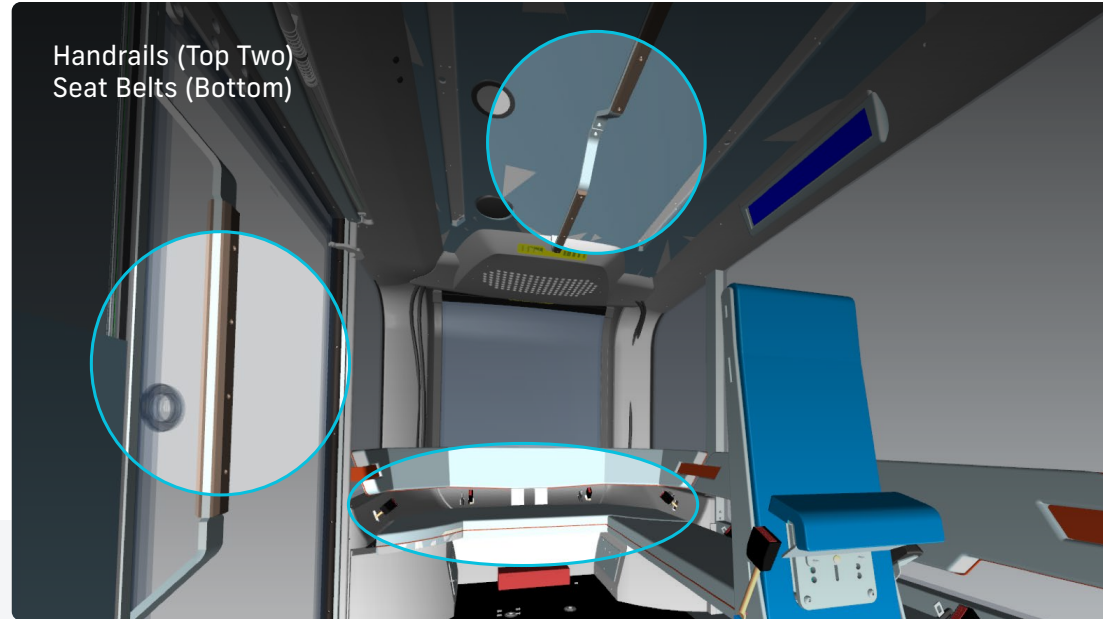

Autonomous Safety Systems

- LiDAR and radar sensors act as redundant systems to detect a number of similar objects
- Auto Drive, which slows down or brings Olli to a full stop, as it detects static or moving objects that are, or may come into her path. It ensures Olli maintains a safe distance from all objects
- An Onboard Steward continuously monitors any irregularity in auto drive and is fully trained to overtake and manually control at any time, if needed
- Seamless, instantaneous switch-over capability from autonomous to manual mode
- Real-time data collection for continuous improvement

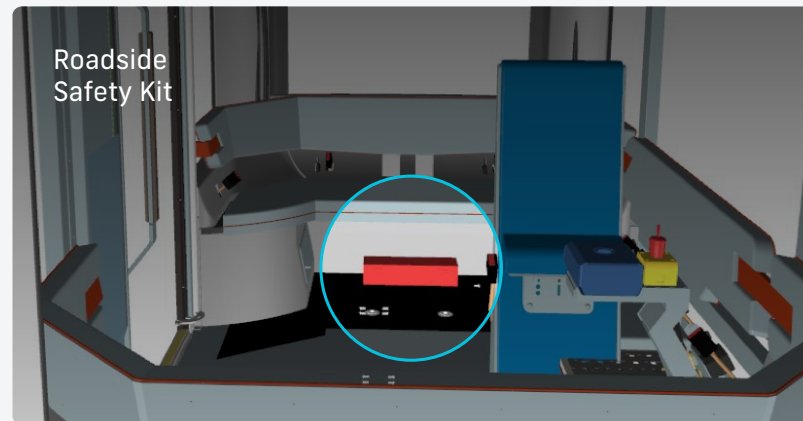

Built-In Standard Safety Systems

- Paravan brake-by-wire and steer-by-wire ensures smooth and reliable braking, with redundant power system
- Manual Parking Mechanical Brake
- Emergency stop button
- Multiple emergency door release buttons
- Eight seat belts
- Handrails
- ADA compliant manual wheelchair restraint system
- ADA compliant wheelchair ramp
- Front and rear bumper sensors
- Tempered and laminated glass windows
- Exterior lighting with side markers and direction indicators
- Egress lighting
- Interior lighting
- Safety Kit
- Fire extinguisher
- Emergency glass breaker
- Vertical Grab Handle
- Horizontal Grab Handle
- Display screen for Onboard Steward displaying forward and side road views
- Front and rear fascia screens with operational alerts
- No-slip floor
- Horn

Egress Procedure

Emergency Egress Overview

In an event of an emergency, the door should be used as the first point of exit. There are two emergency door release buttons which override the electronic push button, as well as allow manual movement of the sliding door.

In the event of a malfunction or the need to open door, locate and push one of the red emergency buttons. One button is located on the exterior right side of the vehicle and the other is located inside at the base of the rear seat.

Window Egress Overview

Window egress should be used if the vehicle:

- Is disabled and the door is unable to operate either electronically or by manual override
- Is turned on its side, fully upside-down, has entered a body of water, is pinned against an object, or any other scenario in which the door cannot be used

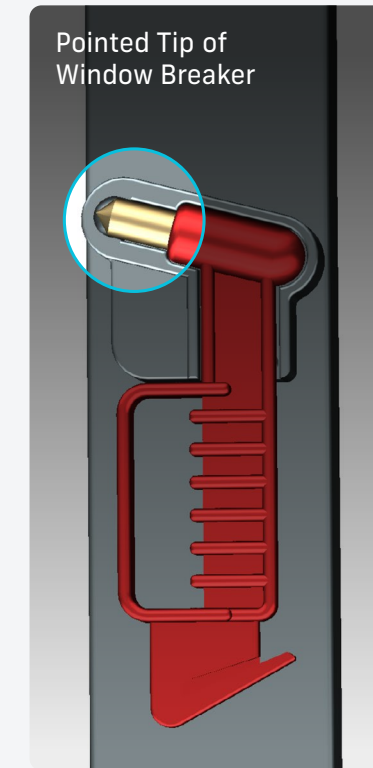
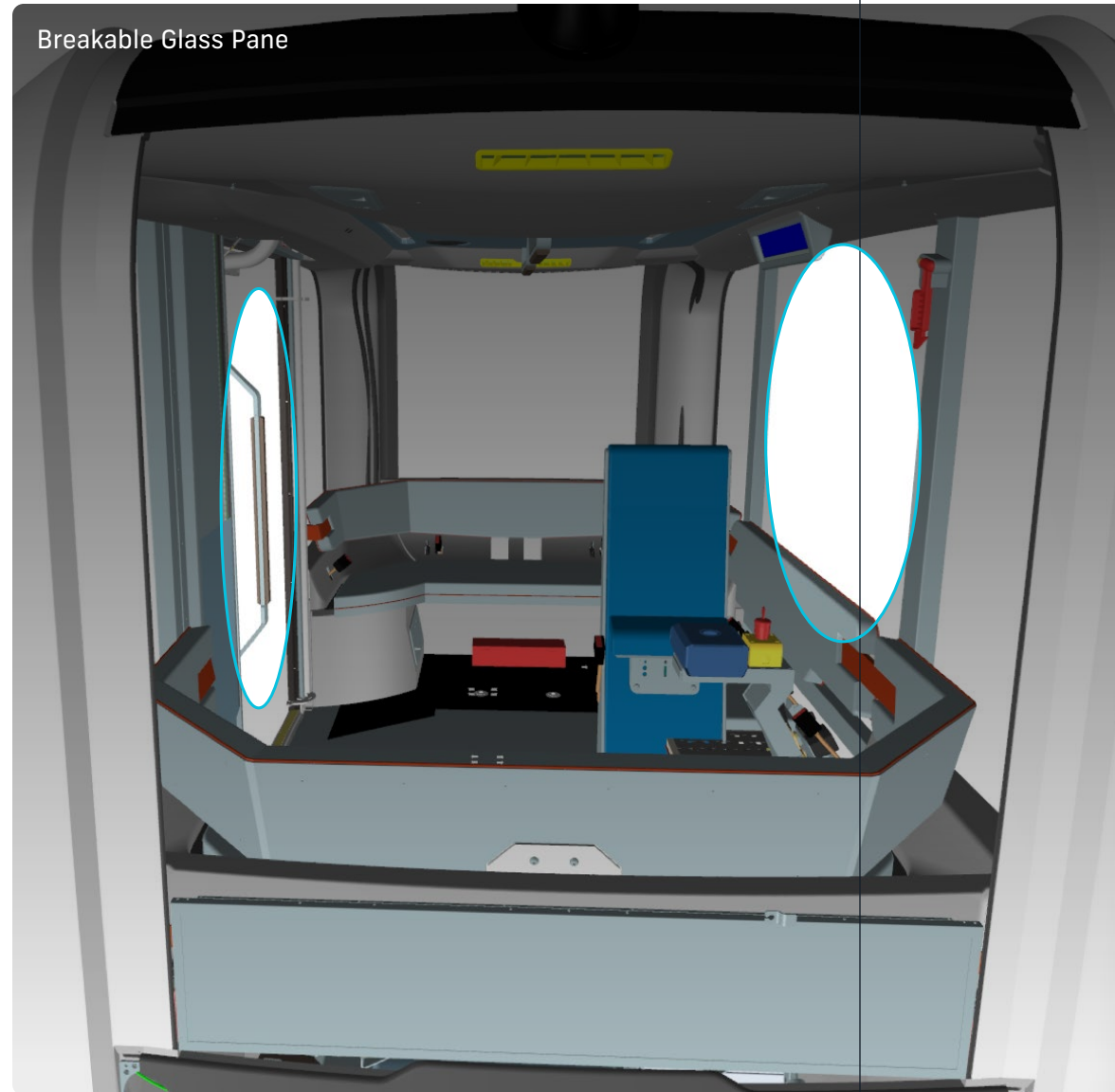

Using the Window Breaker

- **Step 01**
Remove the **Window Breaker** attached to Olli's left B-pillar.
- **Step 02**
With the **Pointed Tip**, strike the center of the glass pane.
- **Step 03**
If the vehicle has overturned and is resting with the door side on the ground, it will be impossible to egress from the door side. In such a case, break the center glass above side seats (opposite the door) and use the bench seats and railings to climb up and out of the vehicle.

⚠ WARNING

When shattering glass, all persons onboard must protect their eyes and face.

Electrical Safety

⚠ WARNING



High voltage system is extremely dangerous and could result in serious injury or death.

Olli is a fully electric vehicle and contains significantly more electronic components and electric wiring compared to traditional combustion engine vehicles.

There are two main voltage systems inside Olli:

- High voltage system
- Low voltage system

Neither the high voltage nor the low voltage system has any serviceable components that need the attention of Olli's owner or Onboard Steward. In case of issues, these components must be only accessed by the Olli service team.

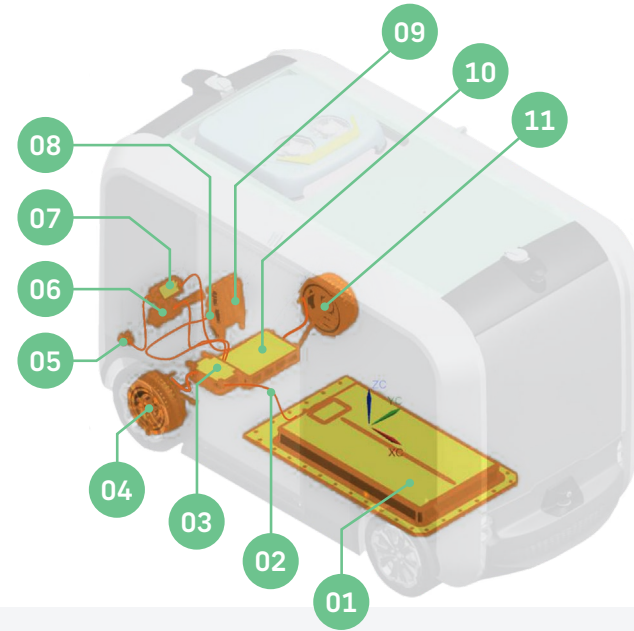

High Voltage System: High voltage cables are typically colored in orange. Never disassemble, remove or replace high voltage components, connectors or cables. In the unlikely event that a fire occurs, immediately contact your local fire emergency responders.

- | | |
|---|--------------------------------|
| 01 High Voltage Battery | 07 Break Out Box |
| 02 High Voltage Cabling | 08 Air Conditioning Compressor |
| 03 High Voltage Distribution Box (HVDU) | 09 DC/DC Converter |
| 04 Hub Motor | 10 Onboard Charger |
| 05 Charge Port | 11 Hub Motor |
| 06 Cabin Heater | |

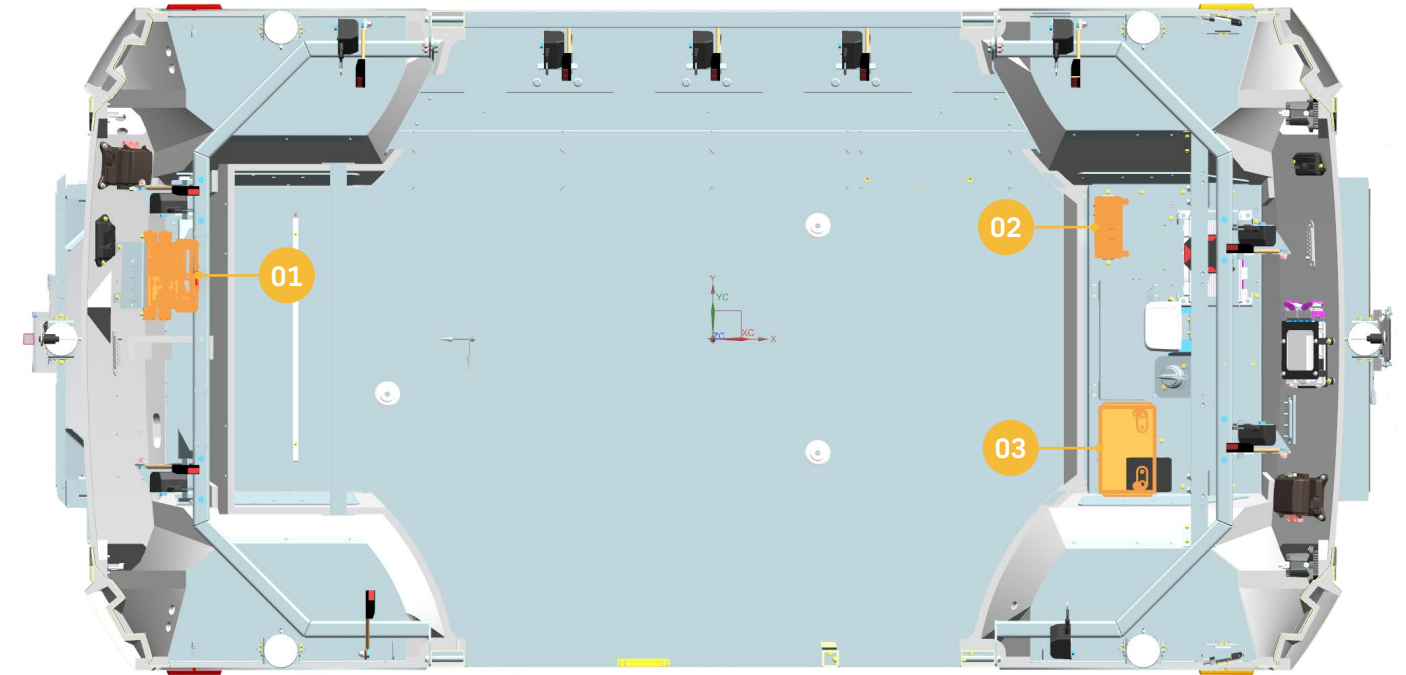

Low Voltage System: Olli has two 12vdc sealed batteries.

The low voltage electrical system is safe from electrical shocks provided all safety guidelines are followed, as with any other type of passenger vehicle using a 12vdc system.





Olli is equipped with a master 12vdc disconnect switch that disables the electrical path from ground.

- | |
|--------------------|
| 01 DC/DC Converter |
| 02 12v Lithium Ion |
| 03 12v SLA Battery |

Hazardous Materials

The following is a list of potentially harmful materials on Olli that one should be aware of when maintaining/ shipping the vehicle. For your safety, always read and follow the instructions printed on fluid containers. In case of battery rupture, major leakage or explosion, evacuate all passengers and quarantine the contaminated area.

Some fluids (battery acid, battery coolant, brake fluid, windshield washer additives, etc.) used in Olli are poisonous and should not be inhaled, swallowed or brought into contact with open wounds.

High Voltage Lithium-Ion Battery	 	<p>INHALATION: Provide good ventilation to clear out any fumes, gases or pungent odors.</p> <p>EYE CONTACT: Rinse eyes with plenty of water for 15 minutes.</p> <p>SKIN CONTACT: Rinse affected skin area with plenty of water and soap or take a shower for 15 minutes.</p> <p>INGESTION: Expose those affected to fresh air and use artificial respiration, if needed. Consult a physician or local poison control center immediately, if any fluid was ingested.</p> <p>Seek medical attention, as needed.</p>
Low Voltage Sealed Lead Acid Battery	 	<p>INHALATION: Move those affected into fresh air and keep them calm under observation. Get medical attention if any discomfort continues. In the case of exposure to contents of an open or damaged battery, immediately flush with plenty of water for at least 15 minutes while removing contaminated clothing and shoes. Get medical attention if irritation develops and persists.</p> <p>EYE CONTACT: Flush thoroughly with water for at least 15 minutes. Hold eyelids open during flushing. If irritation persists, repeat flushing. Get medical attention if irritation develops and persists.</p> <p>INGESTION: Rinse mouth thoroughly with water. DO NOT induce vomiting because of danger of aspirating liquid into lungs. Get medical attention immediately.</p> <p>Under normal conditions of processing and use, exposure to the chemical constituents in this product is unlikely. The battery should not be opened or burned. Exposure to the ingredients contained within or their combustion products could be harmful.</p>

DOT 4
Brake Fluid



EYE CONTACT: May cause slight eye irritation. May cause slight corneal injury.

SKIN CONTACT: Brief contact is essentially non-irritating to skin.

INHALATION: At room temperature, exposure to vapor is minimal due to low volatility. Mist may cause irritation of the upper respiratory tract.

INGESTION: Toxic or fatal, if ingested. For diethylene glycol, a component of this mixture, a lethal dose can be as little as two ounces. Symptoms of diethylene glycol poisoning include severe abdominal cramping, diarrhea, vomiting, sweating, confusion, cardiac abnormalities, neurological abnormalities, infrequent urination, intoxication or CNS depression. If left untreated, product will metabolize to cause metabolic acidosis, renal failure, hyperkalemia, hyponatremia, paralysis, cardiac failure or death. Seek medical attention immediately for poisoning. If ingested, DO NOT wait for symptoms to develop before getting treatment. Read and observe the instructions provided by the manufacturer of the product.

Antifreeze
Coolant



EYE CONTACT: May cause slight eye irritation. May cause slight corneal injury.

SKIN CONTACT: Irritating to skin. Wash with plenty of soap and water.

INHALATION: At room temperature, exposure to vapor is minimal due to low volatility. Mist may cause irritation of the upper respiratory tract.

INGESTION: Toxic or fatal if ingested. For diethylene glycol, a component of this mixture, a lethal dose can be as little as two ounces. Symptoms of diethylene glycol poisoning include severe abdominal cramping, diarrhea, vomiting, sweating, confusion, cardiac abnormalities, neurological abnormalities, infrequent urination, intoxication or CNS depression. If left untreated, product will metabolize to cause metabolic acidosis, renal failure, hyperkalemia, hyponatremia, paralysis, cardiac failure or death. Seek medical attention immediately for poisoning. If ingested, DO NOT wait for symptoms to develop before getting treatment. Read and observe the instructions provided by the manufacturer of the product.

R134a
Refrigerant



EYE CONTACT: Rapid evaporation of liquid in contact with the eye will damage it. Hold eyelids apart and flush eyes with plenty of water for at least 15 minutes. Get medical attention.

SKIN CONTACT: Rapid evaporation of liquid may cause frostbite. Take off all contaminated clothing immediately if not stuck to the skin. Flush area with lukewarm water. Do not use hot water.

INHALATION: Rapid evaporation of the liquid may cause frostbite. Vapor is heavier than air and can cause suffocation. Remove from exposure, move to fresh air, and lie down. Keep patient warm and at rest. Artificial respiration and/or oxygen may be necessary. Consult a physician.

INGESTION: Toxic or fatal, if ingested. For diethylene glycol, a component of this mixture, a lethal dose can be as little as two ounces. Symptoms of diethylene glycol poisoning include severe abdominal cramping, diarrhea, vomiting, sweating, confusion, cardiac abnormalities, neurological abnormalities, infrequent urination, intoxication or CNS depression. If left untreated, product will metabolize to cause metabolic acidosis, renal failure, hyperkalemia, hyponatremia, paralysis, cardiac failure or death. Seek medical attention immediately for poisoning. If ingested, DO NOT wait for symptoms to develop before getting treatment. Read and observe the instructions provided by the manufacturer of the product.

Infrastructure

Garage Requirements

To ensure optimal functionality and longevity of your Olli, it is recommended to have a properly equipped garage or storage facility. This is to allow proper clearance for comfortable repair and maintenance procedures. It is beneficial to have the parking location be within range (3.5ft/1m) of a charging station. Parking areas should be protected against weather effects and safety equipment must be available.

Regulations require personal protective equipment (PPE) be readily accessible in the storage facility:

- Proper marking kit to denote EV storage warnings
- Protective gloves
- Facial protective screen/safety glasses
- Safety shoes
- Power-checker
- First aid kit
- Fire extinguisher



The list below summarizes the technical prerequisites for Olli's storage and recharging system.

- The minimum recommended ceiling height is 15ft (4.5 m)
- The minimum recommended width is 10ft (3m)
- The minimum recommended depth is 20ft (6m)
- The temperature for storage area must be between 52°F (11°C) and 88°F (31°C)
- A well-controlled ventilation system

RTK Base Station

The RTK base station system enhances the positional accuracy of autonomous vehicle navigation. This is achieved by sending relation offsets from a stationary GPS antenna, with a fixed, known position, to Olli via cellular transmission.

RTK utilizes multi-constellation dual-frequency GNSS products including GPS, GLONASS, Galileo, and Beidou.

RTK Base Station (Box Only with Solar Shield)

Dimensions	26" x 12" x 20" (660 mm x 305 mm x 508 mm)
Weight	40 lbs (18 kg)
Input	90~305 VAC
Communications	Cellular (4G)

Horizontal Position Accuracy (RMS)

Single Point L1	59 in (1.5 m)
Single Point L1/L2	47 in (1.2 m)
SBASS	24 in (60 cm)
RTK	1 cm + 1 ppm

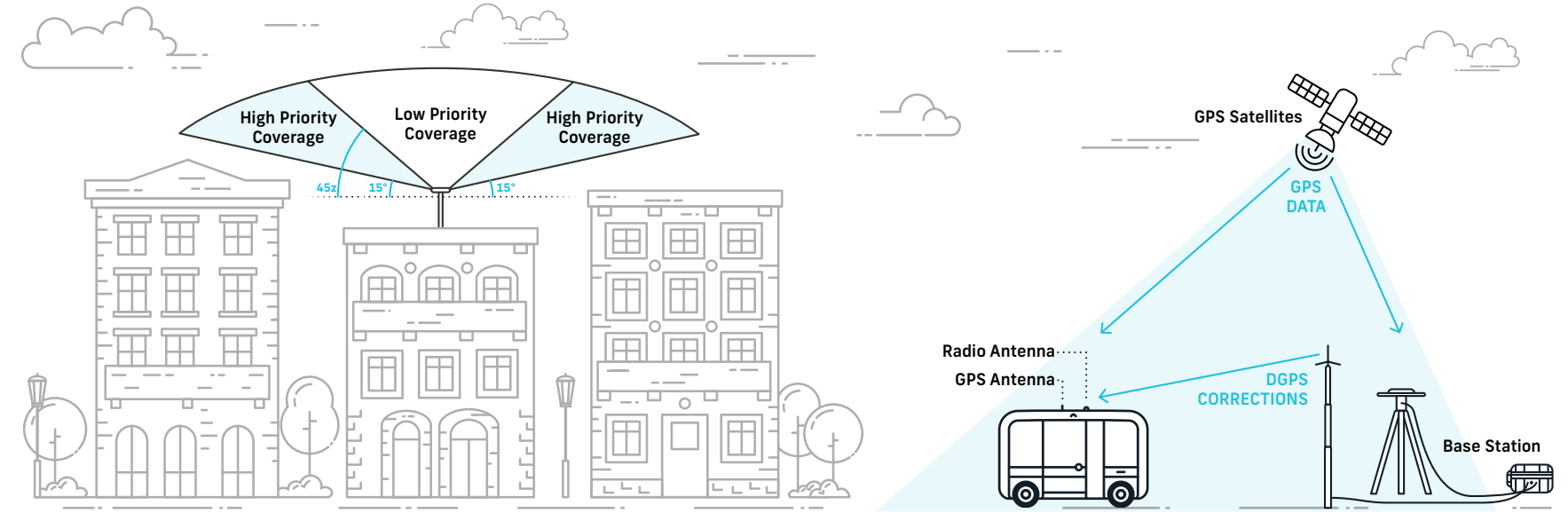

RTK Requirements

- Ideal Performance Operational Radius: <6 miles (<10 km) from vehicles
- Access to 110V-220V power source
- Constant 24/7 power supply
- Solid and steady cell coverage
- Flat rooftop location to mount RTK base station
- GPS antenna on top of building must have clear view at 15° above horizon



Internet Requirements

Olli comes standard with one 4G LTE mobile connection and modem inbuilt to connect to Internet in real time. **Active cellular data plan required.**

Coverage depends on wireless carrier network coverage, but it is important to ensure that the deployment location provides 4G LTE coverage at full strength throughout the route without any fluctuations or signal loss even in dense areas covered with trees, buildings or other obstacles.

3 Separate Internet Connections Required:

- 01 Internet in Garage over hard LAN connection with minimum 35Mbps upload speed per vehicle
- 02 4G LTE mobile connection inside Olli
- 03 4G LTE mobile connection for RTK Base Station

Laptop & Cables

Each Olli come standard with a laptop unit, power adapter, software and necessary cables. The laptop must be connected to power and to internet cable at all times. It will be used by the Onboard Steward to upload Olli data via the Internet, on a daily basis. Laptop, adapter and cables must be permanently placed in the garage where Olli is stored or at a nearby location with 24/7 access.

Power and Charging Requirements

Olli uses an 11 kW onboard charger.

- Type 1 voltage is 110V-240V single/split phase and permits up to 7.7 kW
- Type 2 voltage is 480V three phase Y configuration and permits up to 11 kW
- A dedicated charger is not needed if there are multiple Olli
- 32A is the ideal charger spec for max power from an EDN onboard charger
- All Olli are provided with a charge cable and plug suitable for your area
- Refer to Operator's Manual for more details



Charger Requirements

Voltage Source Per Charger	110-480V, 32A
Vehicle Connector Type	Type 1 (Lockable SAE J1172) or Type 2 (Mennekes)
Infrastructure	Varies based on existing electrical infrastructure
Charge Time	Minimum of 2 hours

General Maintenance

Charging Olli

At least one-hour prior, check Olli's current state of charge (via the Olli Driver Screen app) to confirm sufficient charge for operational needs. If necessary, plug Olli in to charge before proceeding. It will take approximately 2 hours to fully charge Olli.*

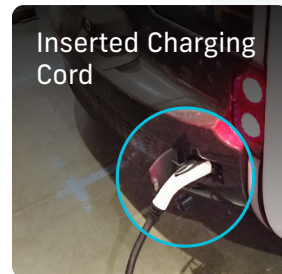
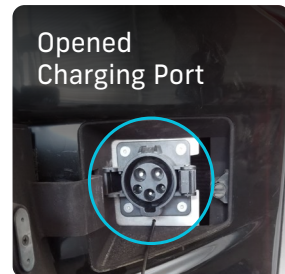

Connecting the Charging Cable

- **Step 01**
Open the **charging port** on the back of Olli.
- **Step 02**
Plug in the **charging cord** (J1772 Outlet Shown).
- **Step 03**
To confirm the charging cord is inserted correctly, Olli's **front lights** will flash off and on.

*Assuming 3-Phase, 480 Volt Input

Cleaning Olli

NOTICE

Exterior

Exterior Panels

Avoid using harsh chemicals, abrasives, solvents or hard brushes on any part of Olli's exterior.

Lights

When cleaning headlights, taillights or light blades, do not use organic substances or scrub with hard brushes. Do not apply wax to the surfaces of lights as it may damage the lenses.

HVAC Unit and GPS Unit

When cleaning, do not let water penetrate any electronic components.

Cameras

Wipe off dirt and dust with a soft cloth, slightly dampened with cold or lukewarm water. Do not use chemicals, caustic agents or

aerosol cleaners.

LiDARs

The ring lenses are acrylic and must not be cleaned with an alcohol-based cleaner. An alcohol-based cleaner will cause the ring lens on the sensor to crack.

If the sensor is caked with mud or bugs, use a spray bottle to loosen the debris. Do not wipe dirt directly from the sensor. Instead, spray it with warm water first. Then use warm, mildly-soapy water and gently wipe the sensor with a clean microfiber towel. Wipe along the curve of the sensor, not top-to-bottom. Spray the sensor with clean water to rinse off the soap and then dry it with a second microfiber towel.

Cleaning Olli (Cont.)

NOTICE

Interior

Interior Panels

Use a vinyl cleaner to regularly clean. Light surface scratches and abrasions can be concealed with a vinyl cleaner or by waxing with a paste wax. Deeper scratches can be removed by lightly buffing with a fine grade of rubbing compound or fine steel wool. Any buffing or sanding has the potential to leave a slight matte finish, so this process should be followed by an application of the wax or vinyl cleaner. After waxing, polish the surface lightly with a clean cotton flannel or jersey. After polishing, wipe gently with a damp cloth to ground any electrostatic charges that may attract dust particles.

Seats

Any vinyl cleaner can be used to clean seats. To remove dirt and dust, use a low power vacuum cleaner, or a soft cloth slightly dampened with cold or lukewarm water. If excess dirt, grease or tar is present on the seat material, spot-clean the area with a vinyl cleaner. Avoid any harsh chemicals or detergents.

Glass Surfaces

Use a vinyl cleaner to remove any stains, dirt and dust. To remove hard stains, use any commercially available standard glass cleaning

product. Wipe away any fluid on the glass surface using a lint-free, microfiber, soft cloth. Avoid using harsh chemicals, abrasives or harsh solvents when cleaning the surface. Do not use excessive water or a soaked sponge, as water may seep into the electronics under the seats.

Floor

Olli's floor is durable, slip resistant and easy to clean. Regularly remove dust and loose debris with a broom or vacuum cleaner. A damp mop with a small amount of neutral detergent or auto scrubber can also be used. To clean grease or oil spots, scrub the floor using a medium-stiff bristled hand brush, a rotocleaner or a single-brush machine (450tr/min with a red disc) with alkaline detergent, if required.

Seat Belts

Check the belts periodically for excessive wear, fraying or cuts. Vinyl cleaners can be used to remove stubborn stains. Do not use excessive water or a soaked sponge, as water may seep into the electronics under the seats.

Tire Maintenance

Good tire maintenance is important to ensure rider safety. Regularly inspect tires and remove any small rocks or foreign objects stuck in the tire tread or between the tire and the rim. Clean the tires any time there is a visible amount of grime or dirt on the surface. A routine monthly cleaning is recommended.

Tires collect more grime compared to other parts of Olli. Proper cleaning of the tires is an important maintenance activity to prevent brake dust and other foreign particles from causing damage. Maintain proper inflation pressure in tires at the recommended level of 50 psi to

meet optimum tire performance, safety, and range. Frequently (at least monthly) check tires (when they are cool) with an accurate tire pressure gauge. Maintaining proper inflation pressure is the single most important thing you can do to promote tire durability and prolong tread life. **DO NOT attempt to mount your own tires.**

- Do not overload Olli with more than recommended number of riders
- Avoid petroleum based tire protectants
- For any issues with tires, please contact the service team

Towing

NOTICE

Use extreme caution when using chains or tow straps. Attaching the wheel straps to the chassis, suspension or other parts of the vehicle's body may cause vehicle damage.

⚠ WARNING

Improper towing technique may lead to injury or death.

Olli is equipped with two (2) **Tow Hooks** (one each at the front and rear), as shown in the picture to the right. For towing, equip the winch to said tow hook and apply tension only in the direction parallel to the length of Olli. When being transported Olli should always be moved on a flat surface, such as a flatbed or shipping crate. Minimal wheel spin is a priority when moving Olli. Load it directly onto the selected method of transport without allowing Olli to roll to the desired location. For more instructions, refer to the shipping procedures section.

Olli Towing Hook

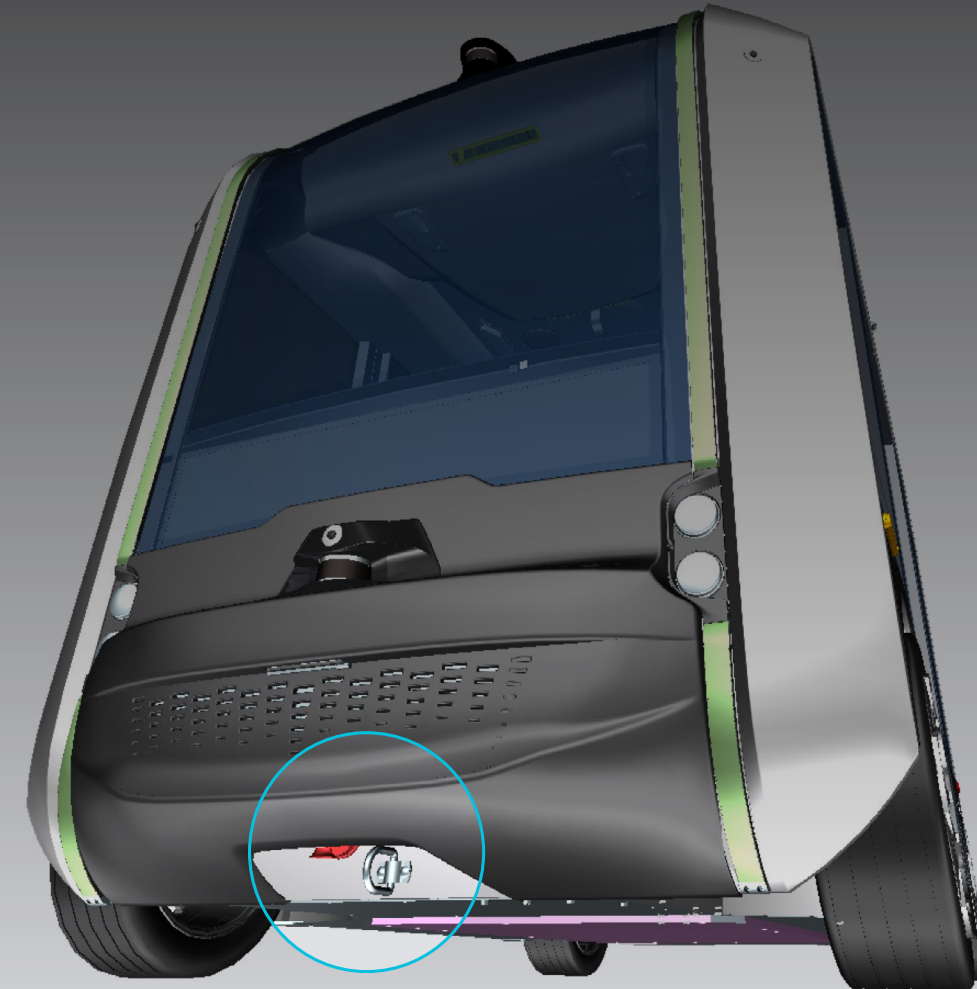

Information Technology

General Data Protection Regulation (GDPR) Requirements

Lawful, Fair and Transparent Processing

The companies that process personal data are asked to process personal data in a lawful, fair and transparent manner.

- *Lawful* means all processing should be based on a legitimate purpose.
- *Fair* means companies take responsibility and do not process data for any purpose other than legitimate purposes.
- *Transparent* means that companies must inform data subjects about the processing activities on their personal data.

Limitation of Purpose, Data and Storage

The companies are expected to limit the processing, collect only that data which is necessary, and not keep personal data once the processing purpose is completed. This would effectively bring the following requirements:

- forbid processing of personal data outside the legitimate purpose for which the personal data was collected
- mandate that no personal data, other than what is necessary, be requested
- ask that personal data should be deleted once the legitimate purpose for which it was collected is fulfilled

Awareness and Training

Organizations must create awareness among employees about key GDPR requirements, and conduct regular training to ensure that employees remain aware of their responsibilities with regard to the protection of personal data and identification of personal data breaches as soon as possible.

Data Subject Rights

The data subjects have been assigned the right to ask the company what information it has about them, and what the company does with this information. In addition, a data subject has the right to ask for correction, object to processing, lodge a complaint, or even ask for the deletion or transfer of his or her personal data.

Consent

As and when the company has the intent to process personal data beyond the legitimate purpose for which that data was collected, a clear and explicit consent must be asked from the data subject. Once collected, this consent must be documented, and the data subject is allowed to withdraw his consent at any moment. Also, for the processing of children's data, GDPR requires explicit consent of the parents (or guardian) if the child's age is under 16.

Privacy by Design

Companies should incorporate organizational and technical mechanisms to protect personal data in the design of new systems and processes; that is, privacy and protection aspects should be ensured by default.

Data Transfers

The controller of personal data has accountability to ensure that personal data is protected and GDPR requirements respected, even if processing is being done by a third party. This means controllers have the obligation to ensure the protection and privacy of personal data when that data is being transferred outside the company, to a third party and/or other entity within the same company.

Data Protection Impact Assessment

To estimate the impact of changes or new actions, a Data Protection Impact Assessment should be conducted when initiating a new project, change, or product. The Data Protection Impact Assessment is a procedure that needs to be carried out when a significant change is introduced in the processing of personal data. This change could be a new process or a change to an existing process that alters the way personal data is being processed.

Cybersecurity Information

Cybersecurity on Olli is based on a tiered approach of implementation, access controls, monitoring, logging and notifications. The systems are designed to reduce the possibility of a cybersecurity event by segmentation of components and applications. No system is completely secure; however we continually evaluate our systems and implementation and update to increase our security of Olli.

Access to the systems, both physically and electronically, is limited to those that require access and is controlled with least-privilege accounts. Olli's network inbound traffic is prohibited except through VPN tunnels established between onboard systems and Local Motors' network systems. Outbound communication for data collection is secured to a cloud-based system with digital certificates.

Network segmentation on the vehicle helps prevent cross-vulnerabilities between critical systems. Logs are regularly reviewed for anomalies and notifications to support teams are sent when an anomalies are detected. Local Motors works with third parties and suppliers to enhance the security of its vehicles and to learn about new cybersecurity best practices and guidelines.

Shipping Procedures

Shipping Procedures

This information is for general knowledge purposes. Only individuals certified to handle transportation of the vehicle should do so. If information beyond this document is needed, please contact your Olli operator.

Olli has a curb weight of approximately 4900 lbs (2222 kgs). Knowing the dimensions is critical when moving Olli. Please reference the Olli's measurements on page 18. Olli may be moved using several different methods.

Short Distance (<50 Miles)

A **standard, rollback flatbed tow truck** should be used. Olli should be secured by a licensed and certified tow truck driver using **standard bonnet-style wheel straps**.



Standard, Rollback Flatbed Tow Truck



Standard Bonnet-Style Wheel Straps

Long Distance (>50 Miles)

Olli fits in a **standard 53-foot semi-trailer**. The trailer must be equipped with either vertical e-track strapping points or permanent tie down points on the floor. Olli can be driven from a dock high platform into the truck or loaded (decked) using a rollback tow truck.

Once inside the truck, Olli should be **secured using straps** laced through or over the wheels. In addition to the wheels being strapped, each wheel must also be choked. No other points on the vehicle are to be used to secure Olli for transport.



Loading Olli Into a Standard 53-Foot Semi-Trailer

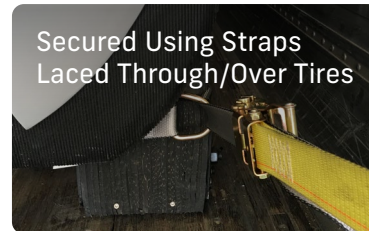

Secured Using Straps Laced Through/Over Tires

International Shipping

Ocean Freight: An overseas “high cube” shipping container needs to be used to accommodate Olli’s overall height. The vehicle can also travel inside a custom-built crate on a “**flat rack.**” A professional shipping company certified for ocean freight transport should be used. Olli travels as hazardous cargo due to Olli’s lithium-ion batteries.

Air Freight: Only a certified freight company should perform the crating of Olli to ensure that she is safely secured for air transport. Olli travels as hazardous cargo due to Olli’s lithium-ion batteries.

**Proper international shipping procedures must be followed.*



Flat Rack



Flat Rack

Vehicle Lift Points

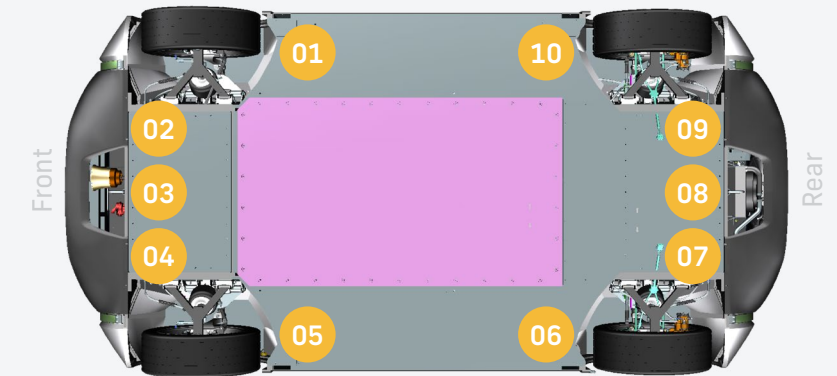

NOTICE

While lifting/placing jacks, make sure bumpers are not in contact, to avoid damage to the bumpers.

Wrapping Olli



Wrapping Olli

Wrapping Olli is a great way to make your riders' experience even more memorable and showcase your brand, company or special event. Please note that the blue sections on the schematics to the right show areas that are not available for wrap or design.

For the latest dimensions and template files, please visit:
LocalMotors.com/OwnersManual

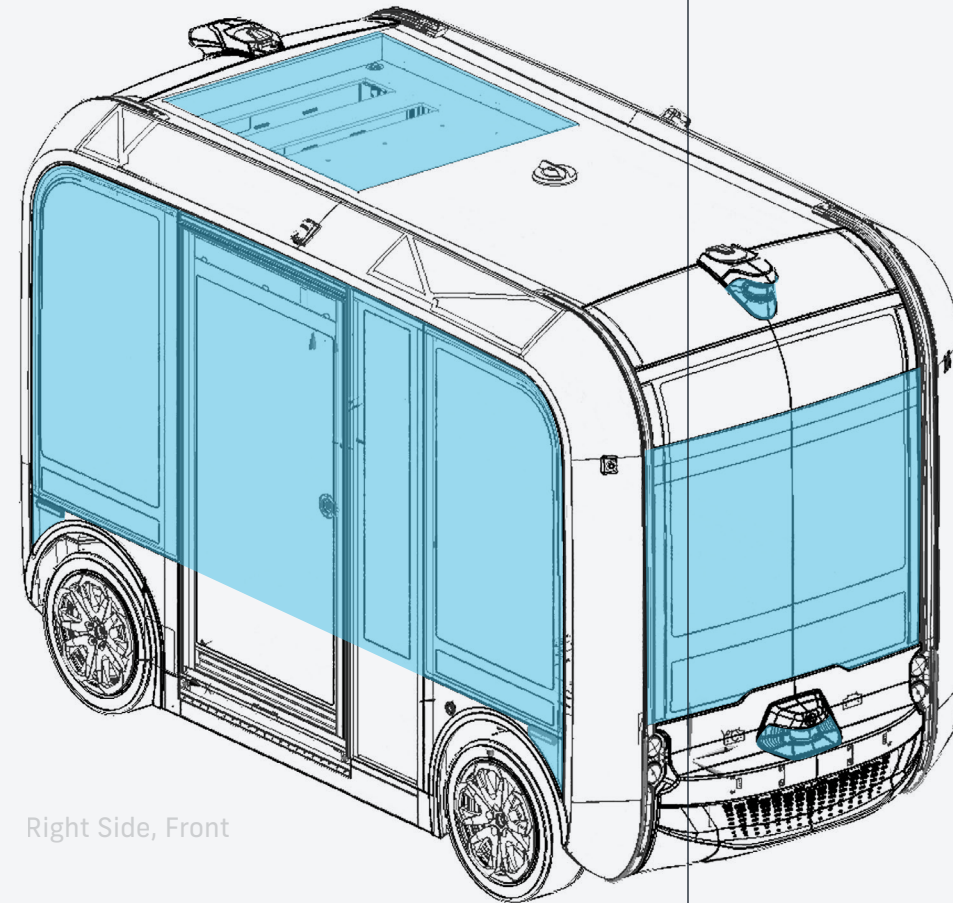

Right Side, Front

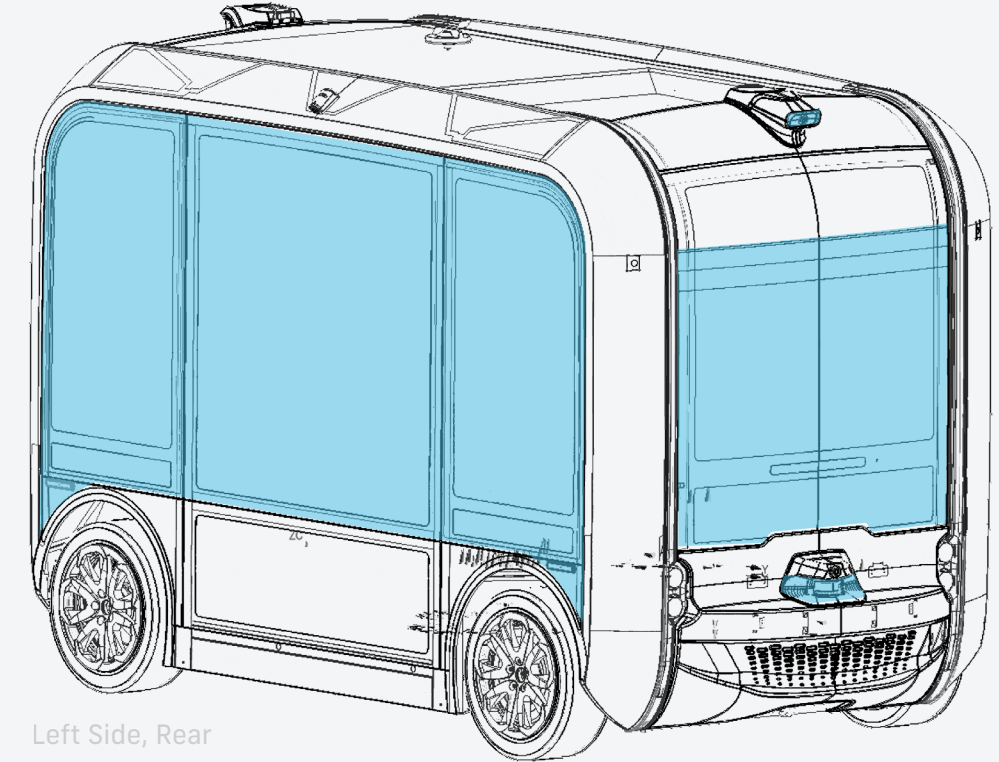

Left Side, Rear

Olli Warranty



Warranty Details

Warranty Period

LM Industries Group, Inc ("LMI") warrants that each new Olli manufactured and/or distributed by Local Motors shall be free, under normal use and with proper maintenance, from defects in material or workmanship (Full Coverage). The Warranty Period is detailed to the right.

2 Year Warranty Period for Battery

The lithium ion battery is warranted to charge and discharge normally and have a remaining capacity of 80% or greater by the end of two (2) years.

4 Year Warranty Period for Hub Motors

The motors (excluding wear items such as seals, lubricants and gaskets) are warranted for parts and labor for four (4) years.

3 Year Warranty Period for Remaining Covered Components

LMI will provide without charge new and genuine Local Motors parts, labor and service calls to replace or repair any covered components furnished by Local Motors and found to be defective in material or workmanship.

Components Covered

- Suspension and steering components
- Power electronics
- Inverters
- Frame
- Replacement parts come with a one year warranty provided the part is installed by an authorized Local Motors channel partner.

LMI Responsibilities

If a defect in material or workmanship is identified during the Warranty Period, LMI will (during normal working hours and through a place of business of a LMI or LMI authorized service representative):

- Provide new, remanufactured or LMI-approved repair parts or assembled components needed to correct the defect. *NOTE: At any time during the repair process, LMI shall be entitled to repair an original part or component with a replacement part or component and the original part or component shall become LMI's exclusive property.*
- Replace service items made unusable by the defect
- Provide labor needed to correct the defect.

Parts replaced under this Warranty are warranted for the remainder of the Warranty Period of the LMI Olli. LMI reserves the right to make any changes in design and improvement without incurring any obligation to incorporate such improvements in any product already shipped from its factory premises or which is in the hands of the customer. OLLI WITH KNOWN FAILED OR DEFECTIVE PARTS MUST BE IMMEDIATELY REMOVED FROM SERVICE.

Customer Responsibilities

The customer is responsible for:

- All transportation expenses, if any, related to a claim under this Warranty
- Labor expenses, except as stated under "LM Responsibilities."
- Federal, state and local taxes, if applicable
- Parts shipping charges in excess of those which are usual and customary
- Expenses to investigate complaints, unless the problem is caused by a defect in material or workmanship
- Giving timely notice of defects covered by this Warranty and promptly making the LM Olli available for repair.
- All claims for coverage under this Warranty must be filed with LM no later than seven (7) days after the expiration of the Warranty Period.
- Giving timely prior written notice of the transfer of ownership of the LM Olli covered by this Warranty. Any transfers of ownership of the LM Olli covered by this Warranty shall not affect the remainder of the original Warranty Period, if any.

This Warranty requires proper and timely maintenance and periodic inspections of the LM Olli as indicated in the operator's manual furnished with each LM Olli.) The cost of routine or required maintenance and service is the responsibility of the customer. The customer is required to keep documented evidence of when and by whom maintenance and service are performed.

Warranty coverage is not extended to repairs or parts and services required as a result of normal or accelerated wear and tear (i.e., brake shoes/pads, tires, light bulbs) and periodic maintenance which is performed in accordance with published schedules (i.e., electric motors brushes, contact or tips, fuses, load wheels).

Additional Notes



