

Installation Instructions

Please read these instructions completely before starting the installation.

TABLE OF CONTENTS

TABLE OF CONTENTS	1
SAFETY CONSIDERATIONS	1
INTRODUCTION	2
DESCRIPTION AND USAGE	2
ELECTROSTATIC DISCHARGE (ESD) PRECAUTION ...	4
SECTION I: MULTIPOISE SINGLE-SPEED AND TWO-SPEED NON-CONDENSING HSI FURNACE MODELS	5
INSTALL FURNACES	5
CONNECT ELECTRICAL COMPONENTS— HEATING	10
CONNECT ELECTRICAL COMPONENTS-COOLING	15
VENTING	15
GAS SUPPLY PIPING	15
ELECTRICAL SUPPLY CONNECTIONS	15
START-UP AND ADJUSTMENT	18
SEQUENCE OF OPERATION	20
SECTION II: SINGLE-SPEED AND TWO-SPEED MULTIPOISE CONDENSING HSI FURNACE MODELS	21
INSTALL FURNACES	24
CONNECT ELECTRICAL COMPONENTS — HEATING	28
CONNECT ELECTRICAL COMPONENTS— COOLING	31
VENTING	32
GAS SUPPLY PIPING	32
CONDENSATE DRAIN CONNECTIONS	32
ELECTRICAL SUPPLY CONNECTIONS	32
START-UP AND ADJUSTMENT	32
SEQUENCE OF OPERATION	33

SAFETY CONSIDERATIONS

Installing and servicing heating equipment can be hazardous due to gas and electrical components. **Only trained and qualified personnel should install, repair, or service heating equipment.** Untrained personnel can perform basic maintenance functions such as cleaning and replacing air filters. All other operations must be performed by trained service personnel. When working on heating equipment, observe precautions in literature, on tags, and on labels attached to or shipped with unit and other safety precautions that may apply.

These instructions cover the minimum requirements and conform to existing national standards and safety codes. In some instances, these instructions exceed certain local codes and ordinances, especially those that may not have kept up with changing residential construction practices. We require these instructions as a minimum for a safe installation.

Wear safety glasses and work gloves. Have a fire extinguisher available during start-up and adjustment procedures and service calls.

Recognize safety information. This is the safety-alert symbol . When you see this symbol on the furnace and in instructions or manuals, be alert to the potential for personal injury.

Understand the signal words DANGER, WARNING, and CAUTION. These words are used with the safety-alert symbol. DANGER identifies the most serious hazards which **will** result in severe personal injury or death. WARNING signifies a hazard which **could** result in personal injury or death. CAUTION is used to identify unsafe practices which **may** result in minor personal injury or product and property damage. NOTE is used to highlight suggestions which **will** result in enhanced installation, reliability, or operation.

WARNING

ELECTRICAL OPERATION HAZARD

Failure to follow this warning could result in personal injury or death.

Turn off gas and electrical supplies to unit and install lockout tag before beginning any installation or modification. Follow operating instructions on label attached to furnace.



CAUTION

CUT HAZARD

Failure to follow this caution may result in personal injury. Sheet metal parts may have sharp edges or burrs. Use care and wear appropriate protective clothing and gloves when handling parts.

INTRODUCTION

IMPORTANT: Only the furnace sizes listed in Tables 2, 3 and 4 can be twinned. Both furnaces must have the same product number, including heating and cooling sizes, to achieve correct operation.

This furnace twinning kit P/N KGATW0601HSI permits connection to the following furnaces to operate as a single unit on the same duct work:

- 2 multipoise, 33.3 inch (846 mm), single-speed, non-condensing furnaces (See Fig. 1, 2, and Table 2.)
- 2 multipoise, 33.3 inch (846 mm), 2-stage, non-condensing furnaces (See Fig. 1, 14, and Table 2.)
- 2 multipoise, 40 inch (1016 mm), single-speed, condensing furnaces (See Fig. 22, 23, and Table 3 or 4.)
- 2 multipoise, 40 inch (1016 mm), 2-stage, condensing furnaces (See Fig. 22, 23, and Table 3 or 4.)



WARNING

UNIT AND PROPERTY DAMAGE HAZARD

Failure to follow this warning could result in unit and property damage.

A non-condensing furnace shall NOT be twinned with a condensing furnace. Two-stage condensing or non-condensing furnaces shall not be twinned with any single stage furnace. Do not twin furnaces that have a different number of blower motor speed taps together. Furnaces shall only be twinned in the positions shown. Variable-speed furnaces shall not be twinned.

DESCRIPTION AND USAGE

Refer to the appropriate section for your furnaces.

SECTION I: Models 58STA, 58STX, 58DLA, 58DLX, 310AAV, 310JAV, 311AAV, 311JAV, PG8MAA, and PG8JAA Multipoise Single-Speed Non-Condensing HSI Furnaces

- Single-Stage Heat with Single-Stage Gas-Heat Thermostat
- Two-Stage Heat with 2-Stage Gas-Heat Thermostat
- Models 58CTA, 58CTX, 312AAV, and 312JAV, Multipoise 2-Stage Non-Condensing HSI Furnaces
- Two-Stage Heat with Single-Stage Gas-Heat Thermostat
- Two-Stage Heat with 2-Stage Gas-Heat Thermostat

SECTION II: Models 58MCA, 58MCB, 58MSA, 58MXA, 58MXB, 340AAV, 340MAV, 345MAV, 350AAV, 350MAV, 490AAV, PG9MAA and PG9MAB Multipoise Single-Speed Condensing HSI Furnaces

- Single-Stage Heat with Single-Stage Gas-Heat Thermostat

SECTION III: Models 58MTA, 58MTB, 352MAV and 352AAV Multipoise 2-Stage Condensing HSI Furnaces

- Two-Stage Heat with Single-Stage Gas-Heat Thermostat
- Two-Stage Heat with 2-Stage Gas-Heat Thermostat

DUCT CONNECTIONS

All furnaces must have a common supply plenum attached to the furnaces or evaporator coils prior to any branch supply trunk or take-off. The height of the plenum should be at least as high (upflow/downflow) or as long (horizontal) as the width of one furnace. Supply air dampers, when used should be installed in the branch ducts, not in the common plenum. Fire or smoke dampers, when required by code may be installed in the common plenum. Refer to the damper manufacturer's ratings installation instructions for proper application. The damper should not create undue restriction in the open position.

All furnaces must be installed to ensure sufficient return air to both furnaces:

- **For upflow furnaces:** A combination of 1 full side of each and bottom inlet plenum or bottom only inlet plenum shall be used for return air to each furnace. The preferred method is to have all return air brought into the bottom of the furnaces through a common bottom plenum. The bottom return-air plenum shall be at least as high as the width of the furnace bottom return-air opening. When there are height limitations, the bottom return-air plenum height can be reduced to 8 in. minimum if 1 entire side return-air opening of each furnace is used in conjunction with the bottom return opening. Rear inlet plenums shall not be used. (See Fig. 1.) Connect all return trunks or branch return ducts to common return plenum.
- **For downflow and horizontal furnaces:** All return air must be brought into the bottom opening of the furnace through a common return air plenum. The return-air plenum shall be at least as long (horizontal) or tall (downflow) as the width of the furnace return-air opening. (See Fig. 2). Connect all return trunks or branch return ducts to common return plenum.
- **For all furnaces:** Fire or smoke dampers, when required by code may be installed in the common return plenum. Refer to the damper manufacturer's ratings installation instructions for proper application. The damper should not create undue restriction in the open position.



WARNING

FIRE HAZARD

Failure to follow this warning could result in improper auxiliary limit operation, fire, personal injury or death.

Do not remove the center return-air partitions between the furnaces.

Staged heating operation is permitted only with this twinning kit. With the single-speed, non-condensing, and condensing furnaces, the left-hand furnace is used for first-stage heat, and both furnaces are used for second-stage heat. With the 2-stage, non-condensing and condensing furnaces, low-gas heat in both furnaces is used for first-stage heat, and high-gas heat in both furnaces is used for second-stage heat. This kit ensures both furnace blowers operate simultaneously so air flows through the duct work rather than recirculating in a loop between the furnaces.

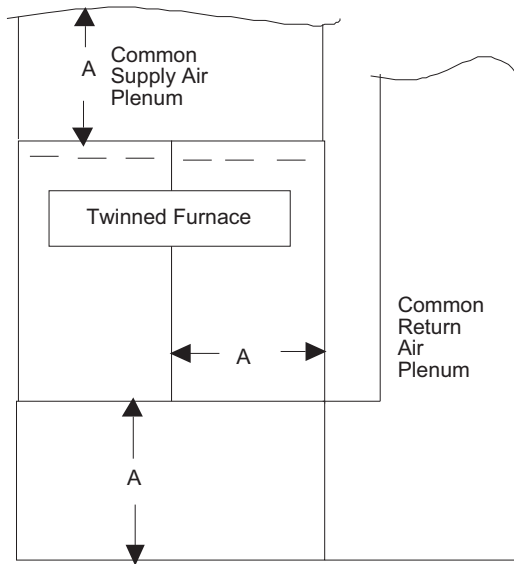

Example 1

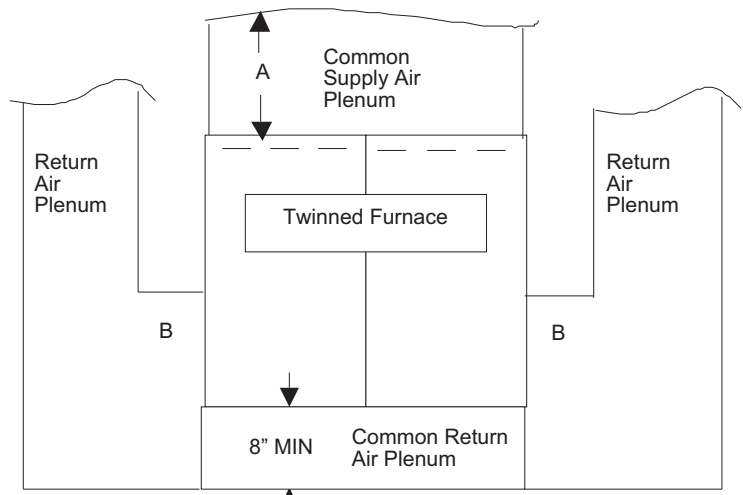

Example 2

Example 1 Notes:

Return duct cannot obstruct access to either furnace
Return Air can enter thru any combination of:

- a. Left side only
- b. Right side only
- c. Bottom only
- d. Back of platform when height of platform equal Dimension "A" as shown
- e. Any combination of a, b, c, d

Example 2 Notes:

When furnaces are installed Back-to-Back (not shown) return duct MUST connect to the common return plenum and side inlet of BOTH furnaces
Return duct cannot obstruct access to either furnace

KGATW

Fig. 1 - Upflow Ductwork Connections

A02223

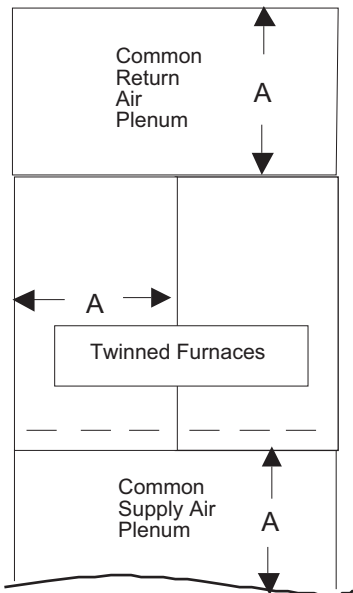

Example 3 - Downflow Applications

Example 3 Notes:

Do not connect return air to any side of the furnace
Connect return air plenum as shown

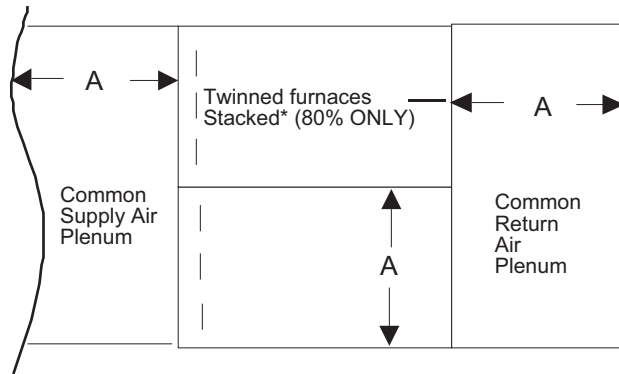

Example 4 - Horizontal Applications

Example 4 Notes:

Do not connect return air to any side of furnace.
Do not stack condensing furnaces of top of each other
When furnaces are installed Side-by-Side (not shown), return connection is similar. Depth of plenum Dimension "A" must equal to the front width of one furnace

Fig. 2 - Downflow/Horizontal Ductwork Connections

A02224

Table 1 – Kit Contents

DESCRIPTION	PART NO.	QUANTITY
Sealing tape		2
External extension harness	327962-701	1
Main twinning harness	327957-701	1
Secondary twinning harness	327959-701	1
Two-stage furnace wiring diagram	327891-101	1
Single-stage furnace heat wiring diagram	327893-101	1
Single-stage furnace/two-stage heat wiring diagram	327892-101	1
Label	327956-101	1
Tape		1
Bag Assembly includes:		
Snap bushing		2
Screws (HEX HD 6B X ¾)		10
Screws (flat head)		1
Wire tie		4
Clamps		2
Installation Instructions		1

KGATW

NOTE: As a result of staged heating with single-speed furnaces, the air temperature distribution in the supply plenum may be uneven when only 1 furnace is heating.

NOTE: Refer to the Installation, Start-Up, and Operating Instructions supplied with each furnace for information on venting, clearances, start-up, maintenance, and other information not covered in this publication.

See Table 1 for kit contents.

**ELECTROSTATIC DISCHARGE (ESD)
PRECAUTION**

⚠ CAUTION

UNIT DAMAGE HAZARD

Failure to follow this caution may result in unit and component damage.

Failure to follow this caution could result in unit and component damage. Electrostatic discharge can affect electronic components. Take precautions during furnace installation and servicing to protect the furnace electronic control. Precautions will prevent electrostatic discharges from personnel and hand tools which are held during the procedure. These precautions will help to avoid exposing the control to electrostatic discharge by putting the furnace, the control, and the person at the same electrostatic potential.

1. Disconnect all power to the furnace. **DO NOT TOUCH THE CONTROL OR ANY WIRE CONNECTED TO THE CONTROL PRIOR TO DISCHARGING YOUR BODY'S ELECTROSTATIC CHARGE TO GROUND.**
2. Firmly touch a clean, unpainted, metal surface of the furnace chassis which is close to the control. Tools held in a person's hand during grounding will be satisfactorily discharged.
3. After touching the chassis you may proceed to service the control or connecting wires as long as you do nothing that recharges your body with static electricity (for example; DO NOT move or shuffle your feet, DO NOT touch ungrounded objects, etc.).
4. If you touch ungrounded objects (recharge your body with static electricity), firmly touch furnace again before touching control or wires.
5. Use this procedure for installed and uninstalled (ungrounded) furnaces.
6. Before removing a new control from its container, discharge your body's electrostatic charge to ground to protect the control from damage. If the control is to be installed in a furnace, follow items 1 through 5 before bringing the control or yourself into contact with the furnace. Put all used AND new controls into containers before touching ungrounded objects.
7. An ESD service kit (available from commercial sources) may also be used to prevent ESD damage.

SECTION I: MULTIPOISE SINGLE-SPEED AND TWO-SPEED NON-CONDENSING HSI FURNACE MODELS

SINGLE-STAGE	SINGLE-STAGE	TWO-STAGE	TWO-STAGE
58STA	310AAV	58CTA	312AAV
58STX	310JAV	58CTX	312JAV
58DLA	311AAV		
58DLX	311JAV		
	PG8MAA		

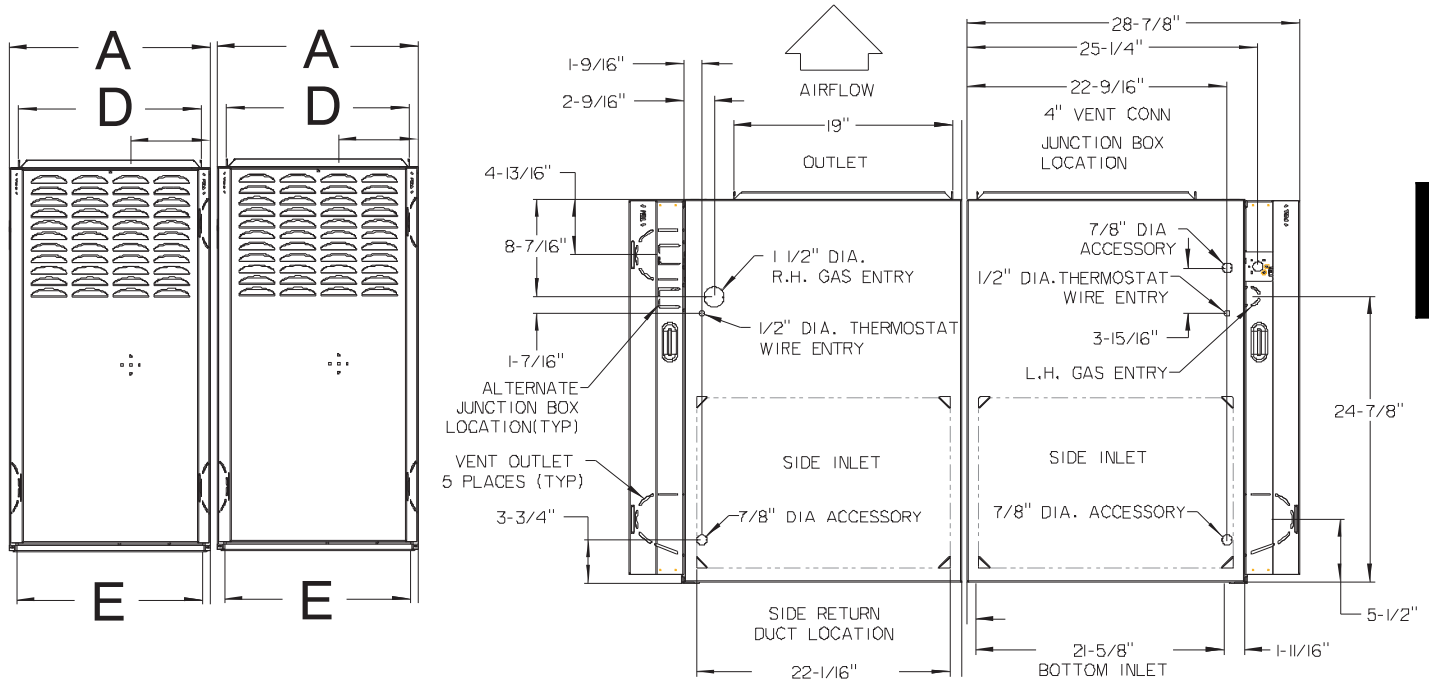

Fig. 3 - Dimensional Drawing

A02235

Table 2 – Dimensions - In. (mm) for Two-Stage with PSC Blower

UNIT SIZE	A	B	C	VENT CONN.*	SHIP WT. – LB. (KG)
045-08/024045	14-3/16 (360)	12-9/16 (319)	12-11/16 (322)	4	104 (47)
045-120/036045	14-3/16 (360)	12-9/16 (319)	12-11/16 (322)	4	107 (49)
070-08/024070	14-3/16 (360)	12-9/16 (319)	12-11/16 (322)	4	111 (50)
070-12/036070	14-3/16 (360)	12-9/16 (319)	12-11/16 (322)	4	115 (52)
070-16/048070	17-1/2 (445)	15-7/8 (403)	16 (406)	4	126 (57)
090-14/042090	17-1/2 (445)	15-7/8 (403)	16 (406)	4	127 (58)
090-16/048090	21 (533)	19-3/8 (492)	19-1/2 (495)	4	140 (64)
090-20/060090	21 (533)	19-3/8 (492)	19-1/2 (495)	4	146 (66)
110-12/036110	17-1/2 (445)	15-7/8 (403)	16 (406)	4	135 (61)
110-16/048110	21 (533)	19-3/8 (492)	19-1/2 (495)	4	146 (66)
110-22/066110	21 (533)	19-3/8 (492)	19-1/2 (495)	4	152 (69)
135-16/048135	21 (533)	19-3/8 (492)	19-1/2 (495)	4	149 (68)
135-22/066135	24-1/2 (622)	22-7/8 (581)	23 (584)	4	163 (74)
155-20/060155	24-1/2 (622)	22-7/8 (581)	23 (584)	4	170 (77)

*5-in. or 6-in. (127 or 152 mm) vent connector may be required in some cases.

NOTE: Throughout these instructions, when the furnace installed side-by-side, the left-hand (LH) side will be referred to as the LH furnace, and the furnace installed on the right-hand (RH) side as the RH furnace. When the furnaces are installed back-to-back, the left-hand (LH) side will be referred to as the LH furnace, and the furnace installed on the right-hand (RH) side as the RH furnace when viewed from the side with the extension harness installed.

PROCEDURE 1 — INSTALL FURNACES

A. Upflow/Downflow, Side-by-Side Position

Refer to Fig. 3 and Table 2 for appearance and dimensional drawing of twinned furnaces and their connection locations.

1. Select 2 identical heating and airflow furnaces. (See Table 2.)
2. Remove outer door and blower access door.

KGATW

3. For upflow and downflow applications:

- a. For **upflow** applications: Bottom return air usage is required as part of any upflow return air configuration. If additional return air is to enter 1 side of each furnace, in addition to bottom return air, cut open 1 entire return-air opening in appropriate side of each furnace. (See Fig. 1.)

⚠ WARNING

UNIT DAMAGE AND FIRE HAZARD

Failure to follow this warning could result in fire, personal injury or death.

DO NOT use the back of the furnace for return-air duct connections, as limit cycling will occur.

b. For **downflow** applications:

Return air can only be connected to bottom opening of furnace. A common return air plenum is required for proper auxiliary limit switch operation. (See Fig. 2.)

⚠ WARNING

UNIT DAMAGE AND FIRE HAZARD

Failure to follow this warning could result in unit damage, fire, personal injury or death.

DO NOT use the back or sides of the furnace for return-air duct connections in the downflow position, as limit switch cycling will occur.

4. Remove bottom closure panels from both furnaces. (See Fig. 4.)
 - a. Lay furnaces on back or sides.
 - b. Remove 2 screws from bottom front panel.
 - c. Pull front panel forward to remove.
 - d. Remove bottom closure panel and discard.
 - e. Reinstall bottom front panel.
 - f. Stand furnaces upright.
5. Apply 2 factory-supplied foam strips to mating side of each furnace. Locate strips equal distance from top and bottom as shown in Fig. 5. Trim off excess material.

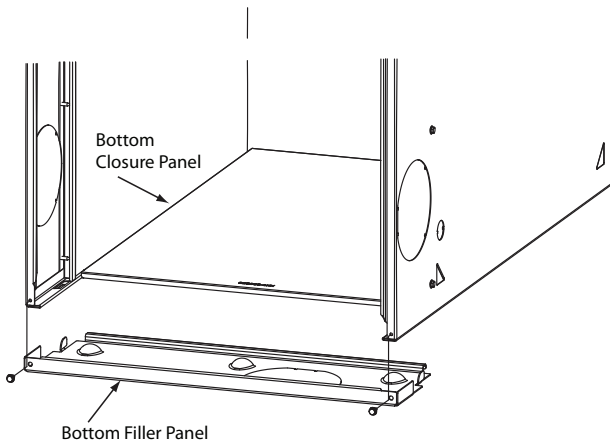

Fig. 4 - Removing Bottom Closure Panel

A10273

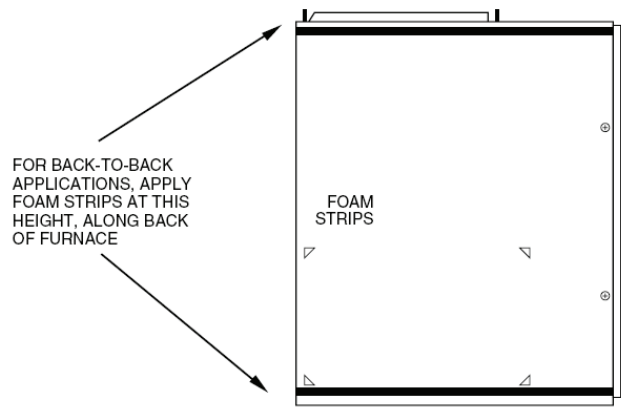

Fig. 5 - Location of Foam Strips

A10274

6. Remove 7/8-in. diameter accessory hole knock-outs in blower compartment from mating sides of furnaces. (See Fig. 3.)
7. Insert a plastic snap bushing through the 7/8-in. knock-out from the outside of the casing.
8. Bend or remove the supply flanges as required for upflow or downflow installation. Refer to the furnace installation instructions for complete details.
9. Position furnaces against each other on return air plenum, supply air plenum or evaporator coil casing. Adjust and shim each furnace to align 7/8-in. diameter holes in both furnaces.
10. Drill two 1/8-in. holes, approximately 1 in. (25 mm) below discharge flange, from inside top of discharge opening and through both furnaces. (See Fig. 6.) Drill two 1/8-in. holes, approximately 1 in. (25 mm) below return air flange, from inside top of return air opening and through both furnaces. (See Fig. 7. as an example).
11. Drive 1 factory-supplied screw through each hole and tighten until furnaces are secure and foam strips have sealed gap between furnaces.
12. Connect return- and supply-air ducts to furnaces. Seal duct connections to prevent air leakage.
13. Move 115-v junction box JB in RH furnace (as viewed from the upflow position) from left-hand side to right-hand side. Refer to furnace installation instructions for complete details.
14. Go to PROCEDURE 2A for Single Stage Furnaces or PROCEDURE 2B for Two Stage Furnaces.

B. Upflow/Downflow, Back-to-Back Position

Refer to Fig. 3 and Table 2 for appearance and dimensional drawing of twinned furnaces and their connection locations.

1. Select 2 identical heating and airflow furnaces. (See Table 2.)
2. Remove outer door and blower access door.
3. Remove bottom closure panels from both furnaces. (See Fig. 4.)
 - a. Lay furnaces on back or sides.
 - b. Remove 2 screws from bottom front panel.
 - c. Pull front panel forward to remove.
 - d. Remove bottom closure panel and discard.
 - e. Reinstall bottom front panel.
 - f. Stand furnaces upright.

4. Applications

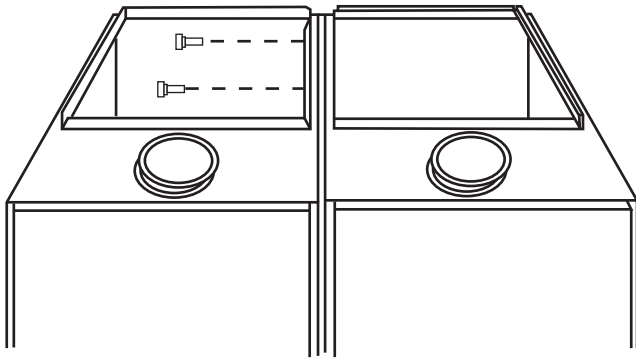

A02232

Fig. 6 - Attaching Furnaces Together at Discharge Opening

- a. For upflow applications:
Bottom return air usage is required as part of any up-flow return air configuration. If additional return air is to enter 1 side of each furnace, in addition to bottom return air, cut open 1 entire return-air opening in appropriate side of each furnace. (See Fig. 2.)

⚠ WARNING

UNIT DAMAGE AND FIRE HAZARD

Failure to follow this warning could result in unit damage, fire, personal injury or death.

DO NOT use the side of the furnace for return-air duct connections in the downflow position, as limit cycling will occur.

- b. For downflow applications:
Return air can only be connected to bottom opening of furnace. A common return air plenum is required for proper auxiliary limit switch operation. (See Fig. 3.)
 5. Apply 2 factory-supplied foam strips to the back of each furnace. Locate strips equal distance from top and bottom as shown in Fig. 5. Trim off excess material.
 6. Determine which side of furnace will be used to route external extension harness. Remove 7/8-in. diameter accessory hole knockouts in blower compartment side selected to attach harness to. (See Fig. 3.)
 7. Bend or remove the supply flanges as required for upflow or downflow installation. Refer to the furnace installation instructions for complete details.
 8. Position furnaces back-to-back on return-air plenum, supply air plenum or evaporator coil casing. Adjust and shim each furnace to align both furnaces.
- NOTE:** External extension harness cannot be used on the same side of the furnace that the return air ducts connect to. Locate harness on opposite side of furnace when side return air is used.
9. Drill two 1/8-in. holes, approximately 1 in. (25 mm) below discharge flange, from inside top of discharge opening and through both furnaces. (Similar to Fig. 6.) Drill two 1/8-in. holes, approximately 1 in. (25 mm) below return air flange, from inside top of return air opening and through both furnaces. (Similar to Fig. 7.)
 10. Drive 1 factory-supplied No. 6 X 3/4-in. LG screw through each hole and tighten until furnaces are secure and foam strips have sealed gap between furnaces.
 11. Connect return- and supply-air ducts to furnaces. Seal duct connections to prevent air leakage.

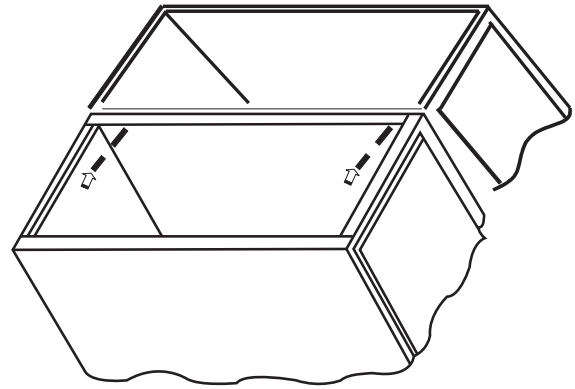

A02219

Fig. 7 - Attaching Furnaces Together at Return Air Opening

12. Move 115-v junction box JB in either furnace from left-hand side to right-hand side if required. Refer to furnace installation instructions for complete details.
13. Go to Step 2A for Single Stage Furnaces or Step 2B for Two Stage Furnaces.

C. Horizontal, Back-to-Back Position

When twinning furnaces in the horizontal position, consideration must be made to the type of building construction. Attic floors should be constructed to support normal live and dead loads of the furnaces and the person(s) servicing them.

Trusses, wood and metal are engineered for specific applications, and may not support the weight of two (2) furnaces suspended from the top chords or the bottom chords of the trusses. Long horizontal spans may flex or sag, resulting in damage to the building. Contact the truss manufacturer for additional design and engineering assistance.

Do not suspend furnaces with straps or suspend furnaces from roof decking.

For attic installations on a platform (See Fig. 8.):

1. Construct a platform from 3/4-in. (76 mm) (nominal plywood), extending out 30 inches (762 mm) from the front of each furnace.
2. Maintain all clearances to combustibles per the furnace Installation, Start-up and Operating Instructions.
3. Follow all additional building codes.
4. Long truss spans may require additional support along the bottom chord of the truss. Consult the truss manufacturer's guidelines for engineering assistance.
5. Long rafter or attic joist spans may require additional support along the bottom of the rafter or joist. Consult local or regional building codes for design and loading requirements.

For suspended installations (See Fig. 9.) Not recommended for wood trusses unless approved by the truss manufacturer or other approved engineering methods):

1. Furnaces may be suspended using two (2) pieces of 1-1/2-in. x 1-1/4-in x 1/4-in. thick cold rolled angle iron underneath the furnaces and four (4) 3/8-in. diameter threaded rods.
2. Allow for at least 9 inches (229 mm) in front of each door for door removal.
3. Each piece of angle iron must be secured to the bottom of each furnace with at least two (2) #8 x 3/4-in. sheet metal screws.
4. Maintain all clearances to combustibles per the furnace Installation, Start-up and Operating Instructions.

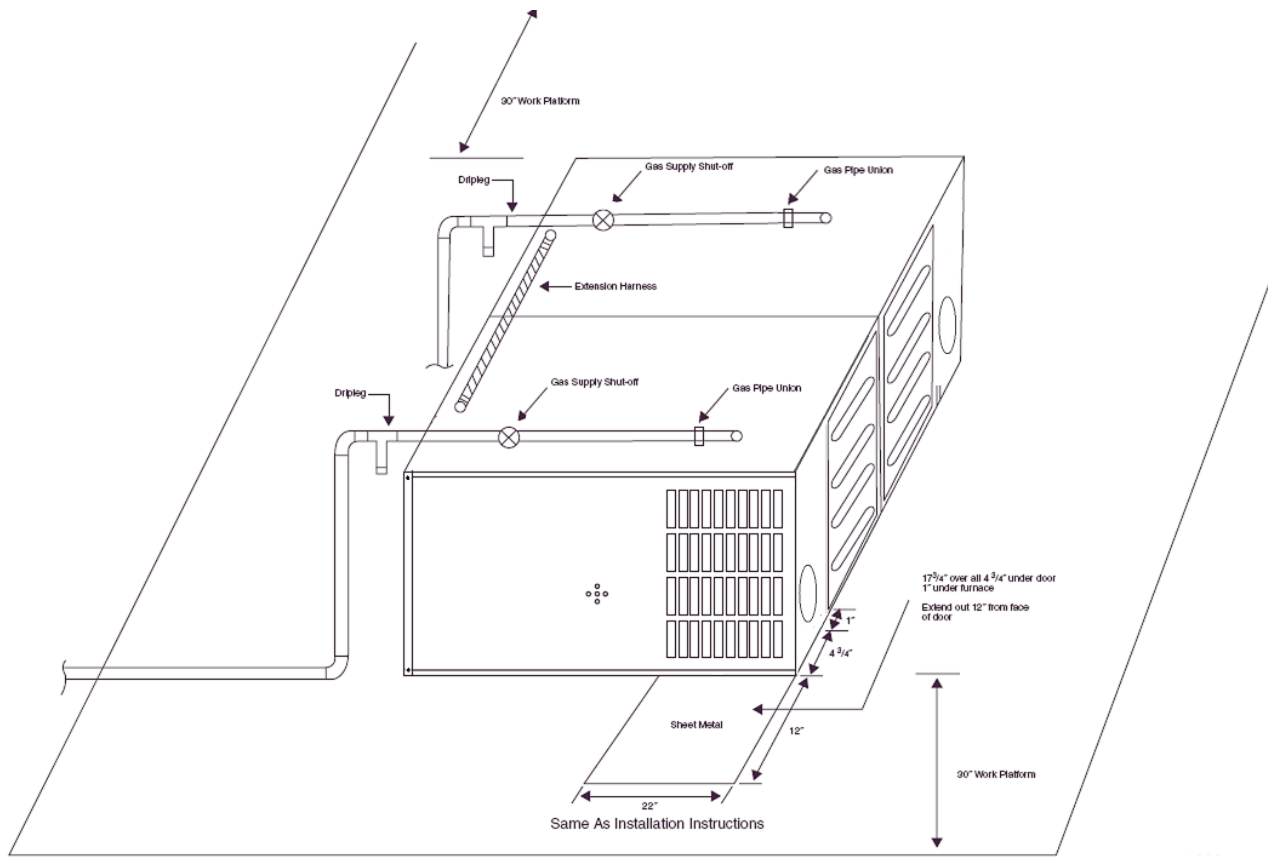

Fig. 8 - Attic Installation of Horizontal Back-to-Back Furnaces

A10275

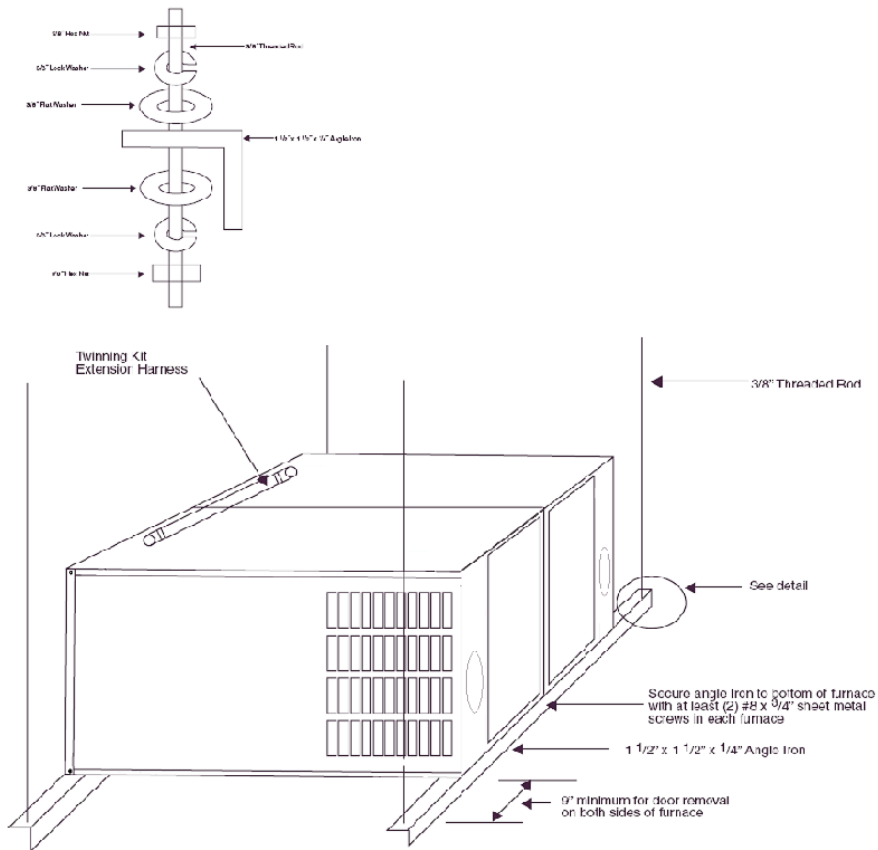

Fig. 9 - Suspended Installation for Horizontal Furnaces Back-to-Back

A10276

5. Unistrut or similar material may be used, provided that the furnaces do not sag in the middle or bend or twist at the support ends. The support material must be secured to the bottom of each furnace in a manner similar to securing angle iron to the furnace.

Refer to Fig. 3 and Table 2 for appearance and dimensional drawing of twinned furnaces and their connection locations.

1. Select 2 identical heating and airflow furnaces. (See Table 2.)
2. Remove outer door and blower access door.
3. Remove bottom closure panels from both furnaces. (See Fig. 4.)
 - a. Lay furnaces on back or sides.
 - b. Remove 2 screws from bottom front panel.
 - c. Pull front panel forward to remove.
 - d. Remove bottom closure panel and set aside for possible use as roll-out protection.
 - e. Reinstall bottom front panel.
 - f. Stand furnaces upright.
4. For All Horizontal applications:

Return air can only be connected to bottom opening of furnace. (See Fig. 2.) A common return air plenum is required for proper auxiliary limit switch operation.

⚠ WARNING

UNIT DAMAGE AND FIRE HAZARD

Failure to follow this warning could result in unit damage, fire, personal injury or death.

DO NOT use the side or back of the furnace for return-air duct connections in the horizontal position, as limit cycling will occur.

5. Apply 2 factory-supplied foam strips to the back of each furnace. Locate strips equal distance from top and bottom as shown in Fig. 5. Trim off excess material.
6. Determine which side of furnace will be used to route external extension harness. Remove 7/8-in. diameter access-hole knockouts in blower compartment side selected to attach harness to. (See Fig. 3.)
7. Position furnaces back-to-back on attic platform or suspended supports. Adjust and shim each furnace to align both furnaces. Follow all clearance to combustible material.
8. If furnaces are installed closer than 12 inches above a deck made from combustible material, provide roll-out protection as shown in the furnace installation instructions. The bottom closure pan may be used for this purpose.

NOTE: DO NOT lay furnace down flat on the side that external extension harness is installed. Raise furnace up a minimum of 1-1/2 inches (38 mm) above deck so harness does not rub on casing or deck.

9. Drill two 1/8-in. holes, approximately 1 in. (25 mm) below discharge flange, from inside top of discharge opening and through both furnaces. (See Fig. 6.) Drill two 1/8-in. holes, approximately 1 in. (25 mm) below return air flange, from inside top of return air opening and through both furnaces. (Use Fig. 6 as an example).
10. Drive 1 factory-supplied No. 6 X 3/4-in. LG screw through each hole and tighten until furnaces are secure and foam strips have sealed gap between furnaces.
11. Connect return- and supply-air ducts to furnaces. Seal duct connections to prevent air leakage.

12. Move 115-v junction box JB in either furnace from left-hand side to right-hand side if required. Refer to furnace installation instructions for complete details.
13. Go to PROCEDURE 2A for Single Stage Furnaces or PROCEDURE 2B for Two Stage Furnaces.

D. Horizontal, Stacked Together

When twinning furnaces in the horizontal position, consideration must be made to the type of building construction. Attic floors should be constructed to support normal live and dead loads of the furnaces and the person(s) servicing them.

Trusses, wood and metal are engineered for specific applications, and may not support the weight of two (2) furnaces suspended from the top chords or the bottom chords of the trusses. Long horizontal spans may flex or sag, resulting in damage to the building. Contact the truss manufacturer for additional design and engineering assistance.

Do not suspend furnaces with straps or suspend furnaces from roof decking.

For attic installations on a platform, see Fig. 10:

1. Construct a platform from 3/4-in. (nominal plywood), extending out 30 inches (762 mm) from the front of each furnace.
2. Maintain all clearances to combustibles per the furnace Installation, Start-up and Operating Instructions.
3. Follow all additional building codes.
4. Long truss spans may require additional support along the bottom chord of the truss. Consult the truss manufacturer's guidelines for engineering assistance.
5. Long rafter or attic joist spans may require additional support along the bottom of the rafter or joist. Consult local or regional building codes for design and loading requirements.

For suspended installations, see Fig. 11. Not recommended for wood trusses unless approved by the truss manufacturer or other approved engineering methods):

1. Furnaces may be suspended using two (2) pieces of 1-1/2-in. x 1-1/2-in. x 1/4-in. thick cold rolled angle iron underneath the furnaces and four (4) 3/8-in. diameter threaded rods.
2. Allow for at least 9 inches (229 mm) in front of each door for door removal.
3. Each piece of angle iron must be secured to the bottom of each furnace with at least two (2) #8 x 3/4-in. sheet metal screws.
4. Maintain all clearances to combustibles per the furnace Installation, Start-up and Operating Instructions.
5. Unistrut or similar material may be used, provided that the furnaces do not sag in the middle or bend or twist at the support ends. The support material must be secured to the bottom of each furnace in a manner similar to securing angle iron to the furnace.

Refer to Fig. 3 and Table 2 for appearance and dimensional drawing of twinned furnaces and their connection locations.

1. Select 2 identical heating and airflow furnaces. (See Table 2.)
2. Remove outer door and blower access door.
3. Remove bottom closure panels from both furnaces. (See Fig. 4.)
 - a. Lay furnaces on back or sides.
 - b. Remove 2 screws from bottom front panel.
 - c. Rotate front panel downward to remove.
 - d. Remove bottom closure panel and set aside for possible use as roll-out protection.
 - e. Reinstall bottom front panel.

- f. Stand furnaces upright.
- 4. For all horizontal applications: Return air can only be connected to bottom opening of furnace.
- 5. Apply 2 factory-supplied foam strips to mating side of each furnace. Locate strips equal distance from top and bottom as shown in Fig. 5.
- 6. Remove 7/8-in. diameter accessory hole knockouts in blower compartment from mating sides of furnaces. (See Fig. 3.)
- 7. Insert a plastic snap bushing through the 7/8-in. K.O. from the outside of the casing.
- 8. Position furnaces on top of each other on platform or suspended supports. Adjust and shim each furnace to align 7/8-in. diameter holes in both furnaces.
- 9. Drill two 1/8-in. holes, approximately 1 in. (25 mm) below discharge flange, from inside top of discharge opening and through both furnaces. (See Fig. 6.) Drill two 1/8-in. holes, approximately 1 in. (25 mm) above return air opening flange, from inside blower compartment and through both furnaces. (See Fig. 7.)
- 10. Drive 1 factory-supplied screw through each hole and tighten until furnaces are secure and foam strips have sealed gap between furnaces.
- 11. Connect return- and supply-air ducts to furnaces. Seal duct connections to prevent air leakage.

- 12. Move 115-v junction box JB in RH furnace (as viewed from the upflow position) from left-hand side to right-hand side. Refer to furnace installation instructions for complete details.
- 13. Go to PROCEDURE 2A for Single Stage Furnaces or PROCEDURE 2B for Two Stage Furnaces.

PROCEDURE 2 — CONNECT ELECTRICAL COMPONENTS—HEATING

A. All Single-Stage Models: 58STA, 58STX, 58DLA, 58DLX, 310AAV, 310JAV, 311AAV, 311JAV, PG8MAA, AND PG8JAA Multipoise Single-Speed Non-Condensing HSI Furnaces

⚠ WARNING

FIRE HAZARD

Failure to follow this warning could result in fire, personal injury or death.

Make no connections between the R 24-vac connector in 1 furnace and the R 24-vac connector in other furnace.

See Electrostatic Discharge Precaution Section.

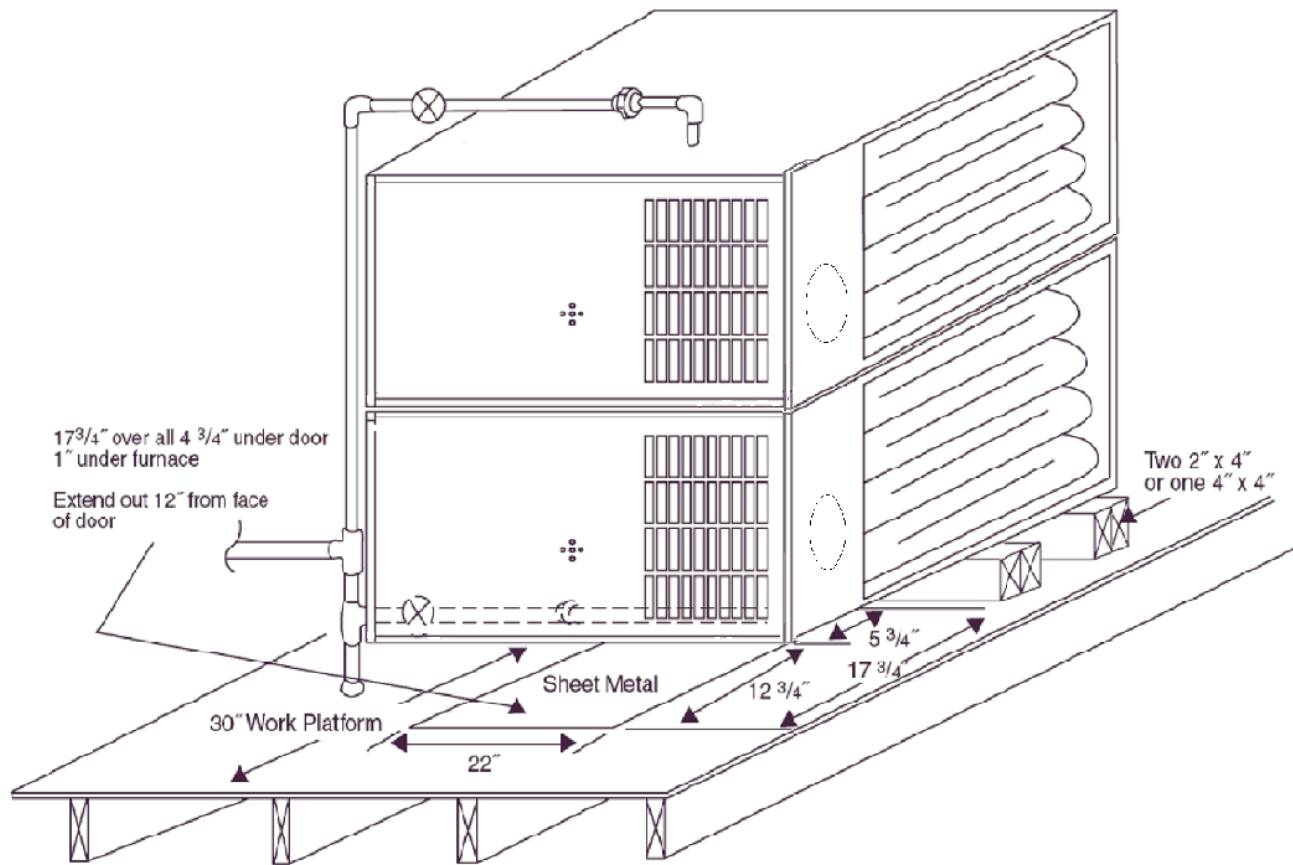

Fig. 10 - Attic Installation of Horizontal Furnace Stacked Together

A10277

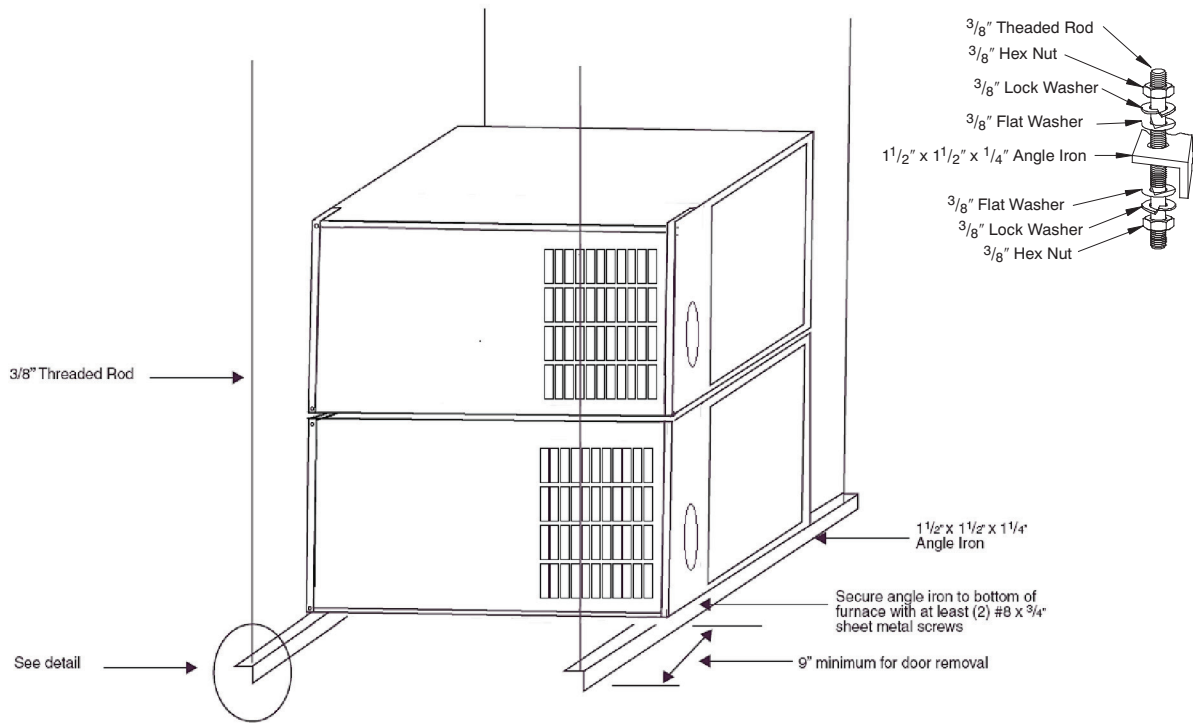

Fig. 11 - Suspended Installation for Horizontal Furnaces Stacked Together

A10278

The twinning kit can be used for single-stage or 2-stage heating operation. There are 3 harness assemblies included in this kit. If the furnaces are side-by-side, only 2 harness assemblies are required. If the furnaces are installed back-to-back, all 3 harness assemblies included in the kit must be used.

1. Remove outer doors and blower access doors from both furnaces.
2. If furnaces are installed back-to-back in any orientation, the external Extension Harness must be used. The harness consists of:
 - a. 54-1/2 inches (1384 mm) of 1/2-in. flexible steel conduit
 - b. (2) 90° conduit connectors
 - c. (1) 4 wire polarized wiring harness
 - d. (1) 2 wire polarized wiring harness
3. Install the Extension Harness as follows:
 - a. Remove lock nuts from the end of each conduit connector.
 - b. Route the end of the harness, labeled “twinning kit harness,” that mates to the TRK relay harness from the outside of the furnace through the 7/8-in. knock-out in the casing to the blower compartment.
 - c. Route the end of the harness that mates to the 4-wire harness through the outside of the furnace through the 7/8-in. knockout in the casing to the blower compartment.
 - d. Install the lock nuts on the 90° conduit connectors.
 - e. Install 2 kit-supplied straps approximately 18 inches (457 mm) from each end of harness.

Single-Stage Heat with Single-Stage Gas-Heat Thermostat (Field-Supplied)

NOTE: This application allows both furnaces to operate as 1 furnace in gas heat mode as determined by single-stage thermostat operation. Both furnaces operate in heating mode simultaneously. See furnace Installation, Start-Up, and Operating Instructions for further details on this heating mode.

1. Install harness labeled “Main Furnace” with TKR on L/H Furnace:

The Main Harness includes the TKR relay and Auxiliary Limit switch on the harness. The harness is also tagged “Main Furnace” near the ends of the plug connector.

- a. Secure relay of TKR harness assembly to LH furnace blower housing using 2 factory-supplied screws. (See Fig. 12.)

NOTE: See Fig. 15 for Single Stage furnace Twinning Kit wiring diagram.

- b. Connect TKR white wire labeled W from TKR to LH furnace control thermostat connection W.
- c. Connect TKR black wire labeled C from TKR to LH furnace control thermostat connection COM 24V.
- d. Connect yellow wire labeled TEST to LH furnace control TEST/TWIN terminal.
- e. If Extension Harness was used, connect 4-wire harness to Extension Harness.

NOTE: If Extension Harness will not plug in to L/H and R/H furnaces, extension harness is installed backward. Remove extension harness and re-install in correct orientation.

2. Install Auxiliary Limit Switch (ALS-M) on L/H furnace:

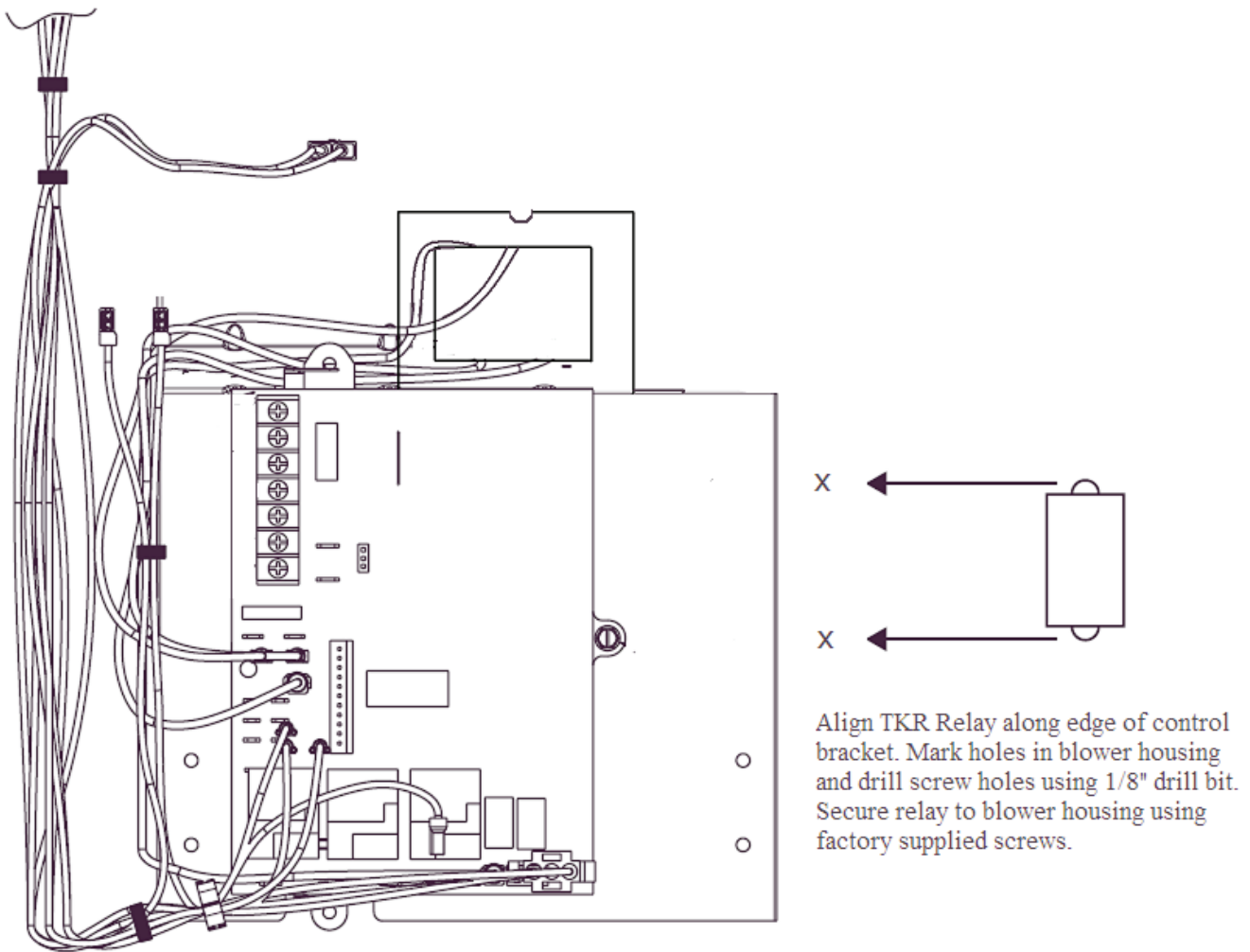
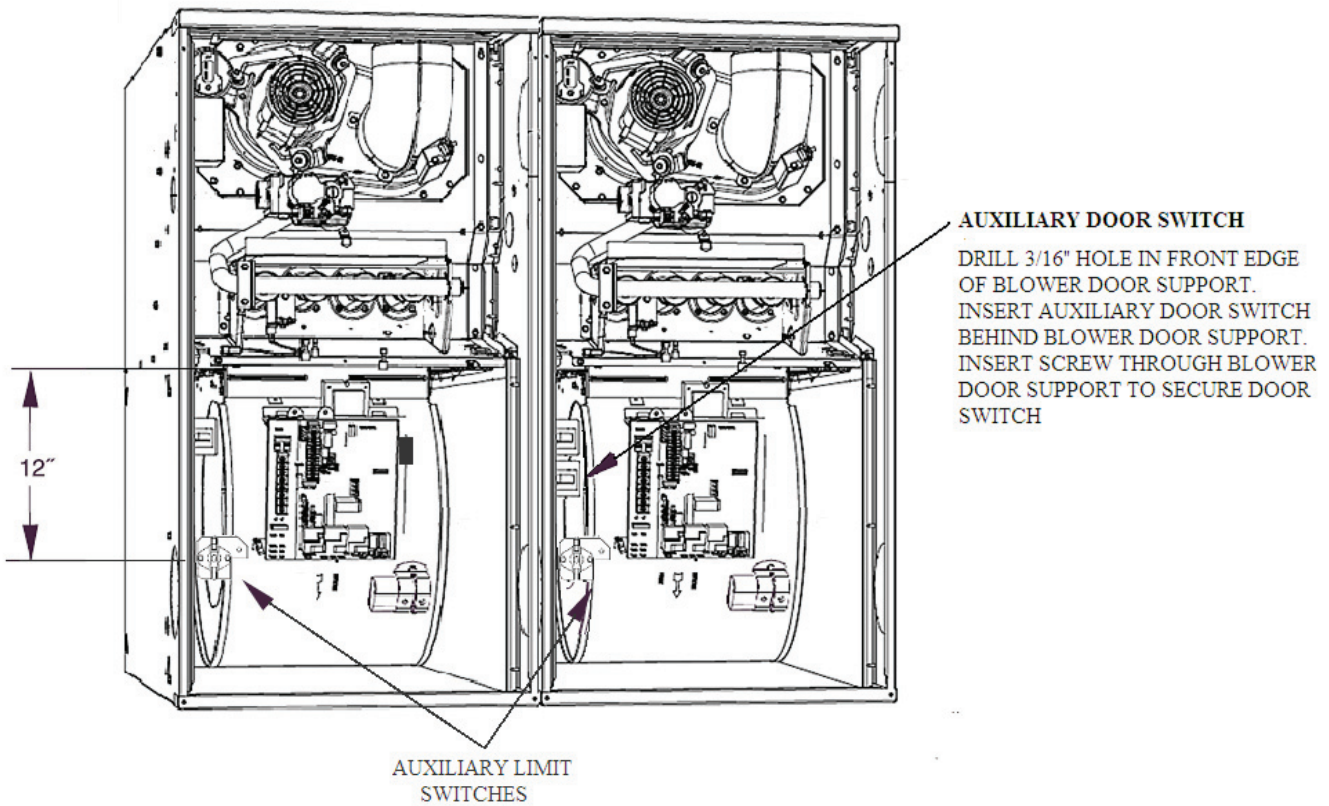

Fig. 12 - TKR Relay Secured with Factory-Supplied Screws

A10279

- a. Drill 1/8-in. hole in blower housing 12 in. (305 mm) below blower shelf. (See Fig. 13.)
 - b. Position ALS-M so reset button faces front of furnace.
 - c. Secure bracket to blower housing using a factory-supplied screw.
 - d. Disconnect red transformer wire from LH furnace control SEC-1 connection.
 - e. Connect red transformer wire connector to ALS-M wire connector PL7 labeled TRAN.
 - f. Connect orange ALS-M wire connector labeled DOOR SWITCH or SEC 1 to LH furnace control SEC-1 terminal.
 - g. If Extension Harness was used, connect 2-wire harness to Extension Harness
3. Install Secondary 4-wire harness on R/H furnace:
The Secondary Harness includes the Auxiliary Door Switch and Auxiliary Limit Switch. The harness is also tagged "Secondary Furnace" near the plug ends of the harness.
- a. Connect red wire labeled R-Secondary to RH furnace control thermostat connection R.
 - b. Connect white wire labeled W-Secondary to RH furnace control thermostat connection W.
 - c. Connect black wire labeled C-Secondary to RH furnace control thermostat connection COM 24V.
 - d. Connect yellow wire labeled TEST SECONDARY from LH furnace control TEST terminal to RH furnace control TEST terminal.
 - e. If the furnaces are side-by-side, route loose ends of 4-wire harness from Secondary furnace to Main furnace through EWIN snap bushings previously installed between furnaces. (See Fig. 4.)
 - f. Connect Secondary 4-wire harness into 4-wire Main harness.
 - g. If Extension Harness was installed, connect 4-wire Secondary Harness to the Extension Harness.
4. Install Auxiliary Limit Switch, ALS-S on Secondary furnace:
- a. Drill 1/8-in. hole in blower housing 12 in. (305 mm) below blower shelf. (See Fig. 13.)
 - b. Position ALS-S with terminals facing front of furnace.
 - c. Secure bracket to blower housing using factory-supplied screw.
5. Install Auxiliary Blower Door Interlock Switch, ILK-1 on Secondary furnace:
- a. Measure along the left edge of the furnace casing, 6 inches (152 mm) down from blower shelf.
 - b. Drill a 3/16-in. clearance hole through front edge of blower door support.
 - c. Insert blower door switch mounting tab behind front edge of blower door support.
 - d. Secure auxiliary door switch ILK-1 using factory-supplied screw.
 - e. Connect 2-Wire Secondary Harness to 2-wire Main Harness that was routed through furnace casings.



KGATW

Fig. 13 - Auxiliary Door Switch

A10280

f. If extension harness was installed, 2-wire Secondary Harness from Secondary to Main Extension Harness.

NOTE: If Extension Harness will not plug in to L/H and R/H furnaces, extension harness is installed backward. Remove extension harness and re-install in correct orientation.

6. Select identical blower motor speed taps at control center connectors in both furnaces.

⚠ CAUTION

UNIT DAMAGE HAZARD

Failure to follow this caution may result equipment damage.

Failure to select identical blower speed taps in both furnaces can result in overheating of furnace components and possible loss of furnace operation and damage to the furnaces.

7. Dress wires to ensure they do not contact sharp or moving parts nor interfere with blower operation, removal of filters, or operation of switches.

8. Make all thermostat connections to LH furnace only. See Fig. 15.

Two-Stage Heat with 2-Stage Gas-Heat Thermostat (Field Supplied)

NOTE: ALL thermostat connections are to be made to LH furnace control ONLY. (See Fig. 16.)

NOTE: This application allows only the LH furnace to operate for first-stage heat mode or both furnaces to operate for second-stage

heat mode as determined by a 2-stage thermostat. See furnace Installation, Start-Up, and Operating Instructions for further details on this heating mode.

To operate furnaces in 2-stage heating mode when a 2-stage thermostat controls the staging, install twinning kit as described in Single-Stage Heat with Single-Stage Gas Heat Thermostat, then modify TKR wiring as follows:

- a. Disconnect TKR white wire labeled W from the LH furnace control thermostat connection W.
- b. Cut off terminal of TKR white wire labeled W and strip 1/4 in. (6 mm).
- c. Connect 2-stage thermostat W2 connection to TKR white wire labeled W.

⚠ CAUTION

PERSONAL INJURY HAZARD

Failure to follow this caution could result in intermittent furnace operation and unit damage.

Supply-air temperature will be uneven left-to-right when only main system is operating.

NOTE: ALL other 2-stage thermostat connections are to be made to LH furnace control ONLY. (See Fig. 16.)

B. All Two-Stage Models: 58CTA, 58CTX, 312AAV, 312JAV Multipoise Two-Speed Non-Condensing HSI Furnaces with PSC Motors

⚠ WARNING

FIRE HAZARD

Failure to follow this warning could result in fire, personal injury or death.

Make no connections between the R 24-vac connector in 1 furnace and the R 24-vac connector in other furnace.

See Electrostatic Discharge Precaution Section.

The twinning kit can be used for single-stage or 2-stage heating operation. There are 3 harness assemblies included in this kit. If the furnaces are side-by-side, only 2 harness assemblies are required. If the furnaces are installed back-to-back, all 3 harness assemblies included in the kit must be used.

1. Remove outer doors and blower access doors from both furnaces.
2. If furnaces are installed back-to-back in any orientation, the external Extension Harness must be used. The harness consists of:
 - a. 54-1/2-in. of 1/2-in. flexible steel conduit
 - b. (2) 90° conduit connectors
 - c. (2) 4 wire polarized wiring harness
 - d. (2) 2 wire polarized wiring harness
3. Install the Extension Harness as follows:
 - a. Remove lock nuts from the end of each conduit connector.
 - b. Route the end of the harness labeled “Twinning Kit Harness” that mates to the TKR relay harness from the outside of the furnace through the 7/8-in. knock-out in the casing to the blower compartment.
 - c. Route the end of the harness that mates to the 4-wire harness through the outside of the furnace through the 7/8-in. knockout in the casing to the blower compartment.
 - d. Install the lock nuts on the 90° conduit connectors.

Two-Stage Heat with Single-Stage Gas-Heat Thermostat (Field Supplied) (See Fig. 17.)

NOTE: This application allows both furnaces to operate as 1 furnace in gas heat mode as determined by single-stage thermostat operation. Both furnaces operate in heating mode simultaneously. See furnace Installation, Start-Up, and Operating Instructions for further details on this heating mode.

1. Install harness labeled “Main Furnace” with TKR on L/H Furnace: The Main Harness includes the TKR relay and Auxiliary Limit switch on the harness. The harness is also tagged “Main Furnace” near the ends of the plug connector.
 - a. Secure relay of TKR harness assembly to LH furnace blower housing using 2 factory-supplied screws. Two new screw holes will have to be drilled using a 1/8-inch drill bit. See Fig. NO TAG for location of holes to be drilled.
 - b. Connect TKR white wire labeled W from TKR to LH furnace control thermostat connection W/W1.
 - c. Connect TKR black wire labeled C from TKR to LH furnace control thermostat connection COM 24V.
 - d. Connect yellow wire labeled TEST to LH furnace control TEST/TWIN terminal.
 - e. If Extension Harness was used, connect 4-wire harness to Extension Harness.
 - f. Turn LHT set-up switch on L/H control board to “OFF.” (See Fig. 14.)

- g. Turn LHT set-up switch on R/H control board to “ON.”

NOTE: If Extension Harness will not plug in to L/H and R/H furnaces, extension harness is installed backward. Remove extension harness and re-install in correct orientation.

2. Install Auxiliary Limit Switch (ALS-M) on L/H furnace:
 - a. Drill 1/8-in. hole in blower housing 12 in. (305 mm) below blower shelf. (See Fig. 13.)
 - b. Position ALS-M so reset button faces front of furnace.
 - c. Secure bracket to blower housing using a factory-supplied screw.
 - d. Disconnect red transformer wire from LH furnace control SEC-1 connection.
 - e. Connect red transformer wire connector to ALS-M wire connector PL7 labeled TRAN.
 - f. Connect ALS-M orange wire connector labeled SEC 1 to LH furnace control SEC-1 terminal.
 - g. If Extension Harness was used, connect 2-wire harness to Extension Harness
3. Install Secondary 4-wire harness on R/H furnace:

The Secondary Harness includes the Auxiliary Door Switch and Auxiliary Limit Switch. The harness is also tagged “Secondary Furnace” near the plug ends of the harness.

- a. Connect red wire labeled R-Secondary to RH furnace control thermostat connection R.
 - b. Connect white wire labeled W-Secondary to RH furnace control thermostat connection W/W1.
 - c. Connect black wire labeled C-Secondary to RH furnace control thermostat connection COM 24V.
 - d. Connect yellow wire labeled TEST SECONDARY to RH furnace control TEST/TWIN terminal.
 - e. If the furnaces are side-by-side, route loose ends of 4-wire harness from Secondary furnace to Main furnace through snap bushings previously installed between furnaces.
 - f. Connect Secondary 4-wire harness into 4-wire Main harness.
 - g. If Extension Harness was installed, connect 4-wire Secondary Harness to the Extension Harness.
4. Install Auxiliary Limit Switch, ALS-S on Secondary furnace:
 - a. Drill 1/8-in. hole in blower housing 12 in. (305 mm) below blower shelf. (See Fig. 13.)
 - b. Position ALS-S with terminals facing front of furnace.
 - c. Secure bracket to blower housing using factory-supplied screw.
 5. Install Auxiliary Blower Door Interlock Switch, ILK-1 on Secondary furnace:
 - a. Measure along the left edge of the furnace casing, 6 inches (152 mm) down from blower shelf.
 - b. Drill a 3/16-in. clearance hole through front of blower door support.
 - c. Insert blower door switch mounting tab behind front edge of blower door support.
 - d. Secure auxiliary door switch ILK-1 using factory-supplied shallow head screw.
 - e. Connect 2-Wire Secondary Harness to 2-wire Main Harness that was routed from Secondary to Main furnace casings.
 - f. If extension harness was installed, 2-wire Secondary Harness to Extension Harness.

NOTE: If Extension Harness will not plug in to L/H and R/H furnaces, extension harness is installed backward. Remove extension harness and re-install in correct orientation.

Thermostat Type	Left Hand LHT Switch 1	Right Hand LHT Switch 1
Single Stage Thermostat	OFF	ON
Two Stage Thermostat	ON	ON

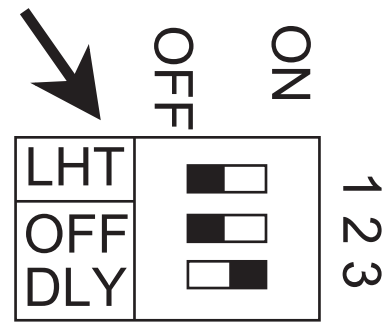

A02221

Fig. 14 - LHT Switch Settings

6. Select identical blower motor speed taps at control motor connectors in both furnaces.

⚠ CAUTION

UNIT DAMAGE HAZARD

Failure to follow this caution may result in unit damage.

Failure to select identical blower speed taps in both furnaces can result in overheating of furnace components and possible loss of furnace operation and damage to the furnaces

7. Dress wires to ensure they do not contact sharp or moving parts nor interfere with blower operation, removal of filters, or operation of switches.
8. Make all thermostat connections to LH furnace only.

Two-Stage Heat with 2-Stage Gas-Heat Thermostat (Field Supplied)

NOTE: ALL thermostat connections are to be made to LH furnace control ONLY. (See Fig. 17.)

NOTE: This application allows both furnaces to operate in low heat for first-stage heat mode or both furnaces to operate in high heat for second-stage heat mode as determined by a 2-stage thermostat. See furnace Installation, Start-Up, and Operating Instructions for further details on this heating mode.

To operate furnaces in 2-stage heating mode when a 2-stage thermostat controls the staging, install twinning kit as described in the two-stage heat with single-stage gas heat thermostat:

- a. Turn LHT set-up switch on L/H control board to “ON.”
- b. Turn LHT set-up switch on R/H control board to “ON.”

NOTE: ALL other 2-stage thermostat connections are to be made to LH furnace control ONLY. (See Fig. 17.)

PROCEDURE 3 — CONNECT ELECTRICAL COMPONENTS-COOLING

⚠ WARNING

ELECTRICAL OPERATION HAZARD

Failure to follow this warning could result in fire, personal injury or death.

Failure to follow warning could result in fire, personal injury or death. Make no connections between the R 24-vac connector in 1 furnace and the R 24-vac connector in other furnace.

When installing twinned outdoor units with twinned gas furnaces, it is necessary to use a field-supplied 24-vac pilot-duty relay and a

field-supplied 24/115-vac transformer as shown in Fig. 15, 16, or 17 to prevent overloading furnace 24/115-vac transformer.

PROCEDURE 4 — VENTING

Refer to Installation, Start-Up, and Operating Instructions supplied with each furnace for venting information.

⚠ CAUTION

UNIT DAMAGE HAZARD

Failure to follow this caution may result in unit damage

When common-venting twinned, Category I (negative-pressure venting), non-condensing furnaces, excessive condensate may occur as a result of oversized vent systems. Dedicated vents and/or proper vent sizing, per the current edition of the National Fuel Gas Code, will reduce the potential for condensation.

PROCEDURE 5 — GAS SUPPLY PIPING

NOTE: All gas connections must be made through exposed outer side of each furnace. Do not common connect any connection other than supply and return-air ducts.

Furnaces are recommended to be provided with a single shutoff valve. However, individual shutoff valves may be required by local codes or jurisdictions. Refer to Installation, Start-Up, and Operating Instructions provided with each furnace for additional gas supply information.

PROCEDURE 6 — ELECTRICAL SUPPLY CONNECTIONS

NOTE: All electrical power connections must be made through exposed outer side of each furnace. Do not common connect any connection other than supply- and return-air ducts.

1. Each furnace shall be connected to its own 115-vac power supply. The twinning kit installation interconnects the furnaces, allowing them to operate as a single furnace. The L1 (black) connection to each furnace must be connected to circuit breakers connected to the same service panel 115-vac phase leg.

On single-phase (residential) systems, each furnace circuit breaker should be located directly across from each other in service panel, or each furnace circuit breaker should be located on the same side of service panel, but must skip 1 space to be connected to the same leg of the 1-phase power supply.

On 3-phase (commercial) systems, each furnace circuit breaker should be located directly across from each other in service panel, or each furnace circuit breaker should be located on the same side of service panel, but must skip 2 spaces to be connected to the same leg of the 3-phase

KGATW

power supply.

The proper 115-vac phasing of furnace connections permits 24-vac transformer phasing as described below.

2. Phasing of the connected 24-vac transformer secondary circuits can be determined with the LED status of both furnaces. See furnace Installation, Start-Up, and Operating Instructions and status code labels on blower doors. The furnaces' transformers' black leads should be connected to

IF:

- a. Both LEDs are on continuously: System phasing is okay.
- b. One or both LEDs are rapidly flashing:
 - (1.) Line voltage polarity is reversed
 - (2.) Reverse SEC-1 and SEC-2 in furnace with rapid flashing LED.
- c. One LED is off, 1 LED is on continuously:
 - (1.) The 24-vac circuit is inoperative on furnace with LED light off.

PR1 connectors and white leads to L2 connectors on controls. If 1 or both LEDs are rapidly flashing, disconnect lead at TEST/TWIN terminal of LH furnace and observe LED at each furnace.

To verify that the furnaces are in phase, check from Main furnace L1 to Secondary furnace L1 with a voltmeter. If the furnaces are in phase, the voltage between both furnaces will be ZERO.

- (2.) Check transformers, auxiliary limits, and door switches in both furnaces and correct problem.
 - d. One or both LEDs are dim or flickering. Furnaces are on different phase legs. Disconnect TWIN/TEST lead. If both LEDs are on continuously when TWIN/TEST is disconnected, furnace line voltage power supply is out of phase.
3. Reconnect lead at TWIN/TEST terminal of LH furnace and observe LED at each furnace. The LEDs will glow steady for proper phasing.

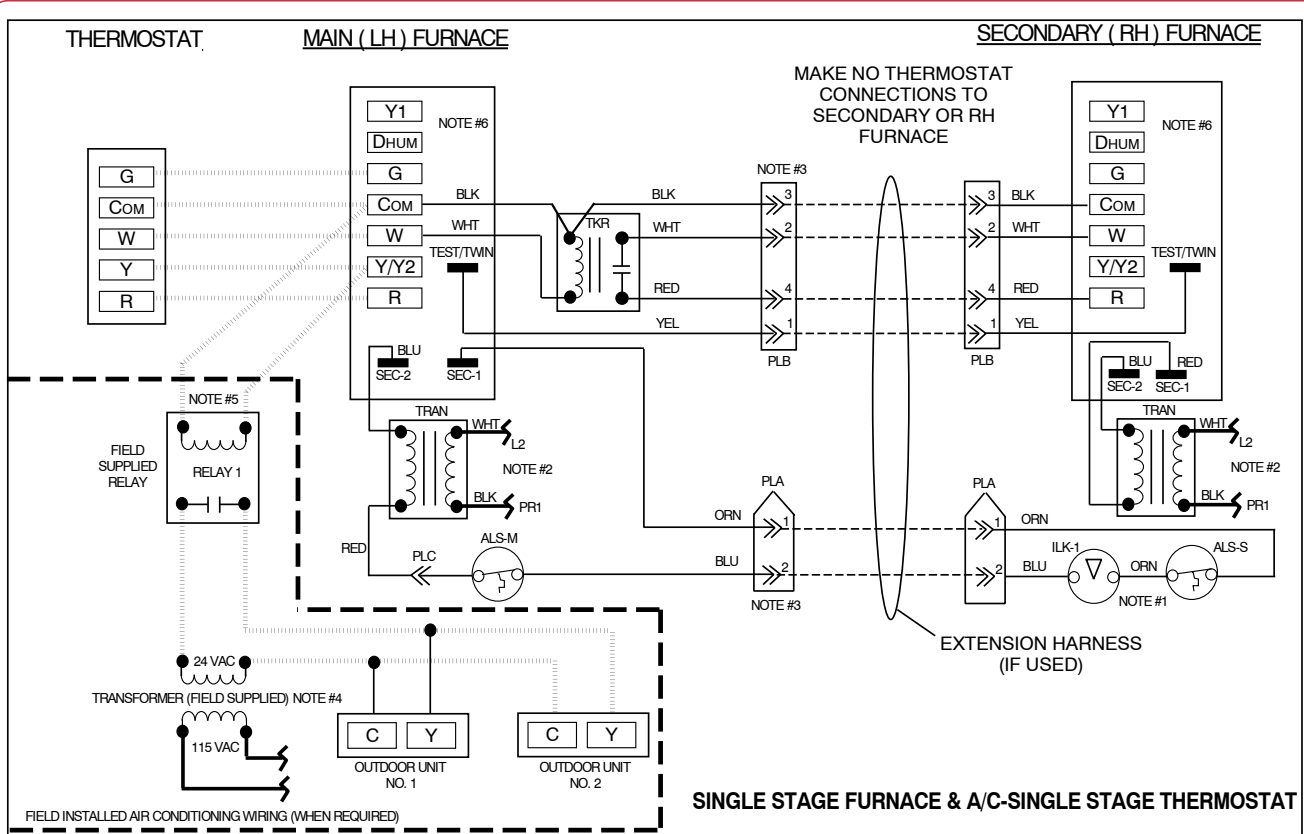

LEGEND:

- ALS-M MAIN AUX. LIMIT SW., OVERTEMP-MANUAL RESET, SPST - (N.C.)
- ALS-S SECONDARY AUX. LIMIT SW., OVERTEMP-MANUAL RESET, SPST - (N.C.)
- ILK-1 SECONDARY AUX. BLOWER DOOR INTERLOCK SWITCH, SPST - (N.O.)
- PLA 2-CIRCUIT TWINNING KIT CONNECTOR
- PLB 4 - CIRCUIT TWINNING KIT CONNECTOR
- PLC 1 - CIRCUIT TWINNING KIT IN-LINE SPLICE
- TEST/TWIN COMPONENT TEST & TWINNING TERMINAL
- TKR TWINNING KIT RELAY, SPST - (N.O.)
- TRAN TRANSFORMER - 115VAC / 24VAC (PART OF FURNACE)
- 115 VOLT WIRING
- TWINNING KIT EXTENSION HARNESS (REQUIRED)
- FIELD WIRING
- FACTORY WIRING (TWINNING KIT)

NOTES:

1. ALS-S and ILK-1 are located in the SECONDARY or RH furnace blower compartment.
2. Primary connections of transformer not shown; refer to furnace wire label.
3. When extension harness is not required PLA and PLB must be routed through holes in casings.
4. Transformer = 115 VAC primary / 24 VAC secondary / 40VA.
5. Relays = 24 VAC coils / pilot duty / normally open.
6. Y1 and DHUM terminal not available on "RED" LED control board.

327893-101 REV. A

Fig. 15 - Single-Stage Furnace and A/C Single-Stage Thermostat

A02227

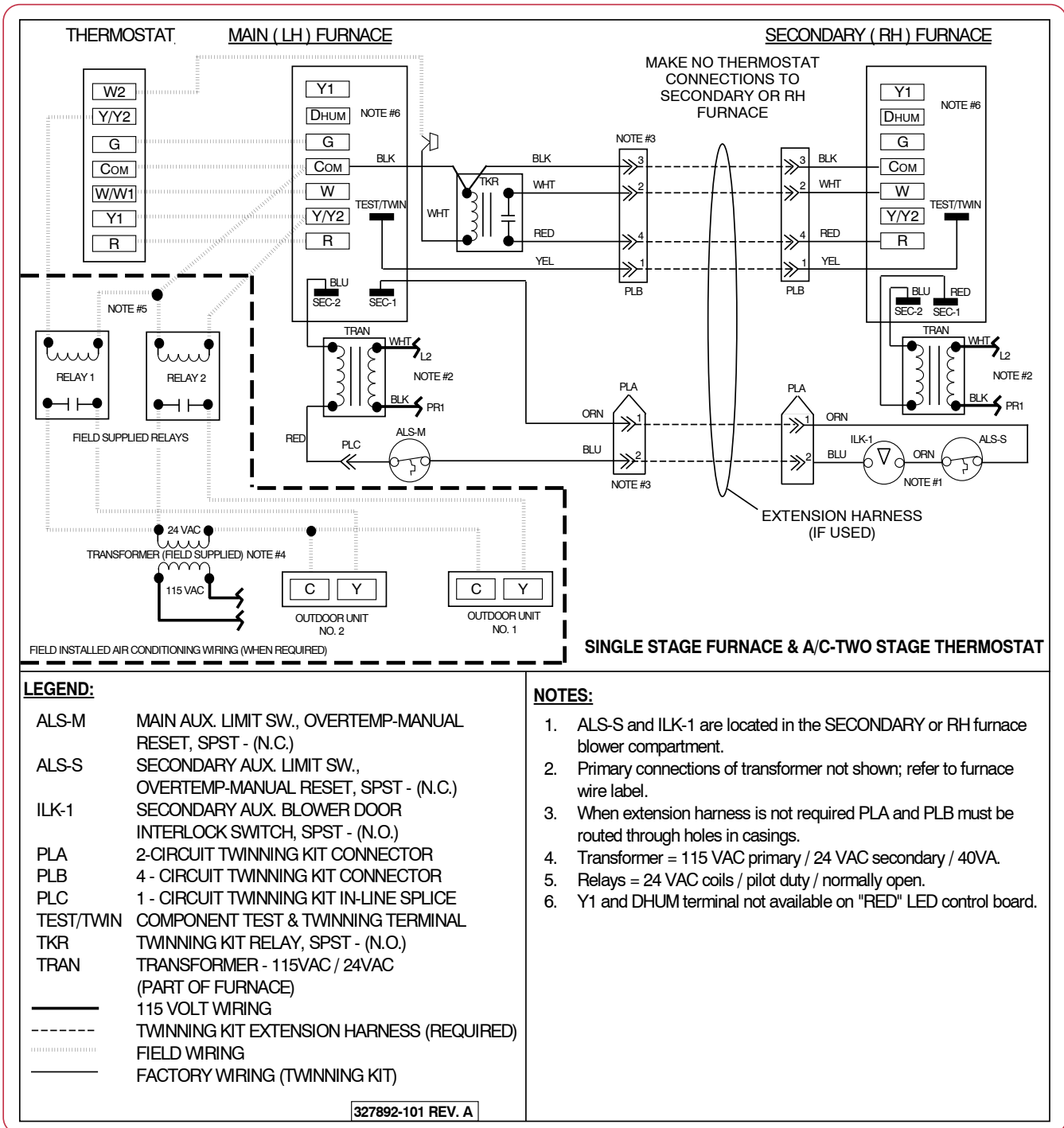

Fig. 16 - Single-Stage Furnace and A/C Two-Stage Thermostat

A02228

PROCEDURE 7 — START-UP AND ADJUSTMENT

Refer to Installation, Start-Up, and Operating Instructions supplied with furnaces for detailed information.

1. Shut off all power and gas to both furnaces.
2. Position blower off delay switches on controls in BOTH furnaces to SAME desired gas heat blower off delay. (See Fig. 18 and 19.) See furnace Installation, Start-Up, and Operating Instructions for further details.
3. Attach twinning connection wiring label above the existing furnace wiring label on the inside of the L/H furnace blower

access door. Use the following labels for the following applications:

Single Stage furnaces with single-stage thermostat, 327893-101
 Single Stage furnaces with two-stage thermostat, 327892-101
 Two Stage furnaces with single-stage or 2-stage thermostat, 327891-101

4. Attach twinning reference label 327956-101 on outside of blower access door of RH furnace blower door.
5. Turn on power and gas to both furnaces.
6. Reinstall blower access doors on both furnaces.
7. Operate furnaces through 2 cycles in each mode to confirm correct operation by operating only thermostat.

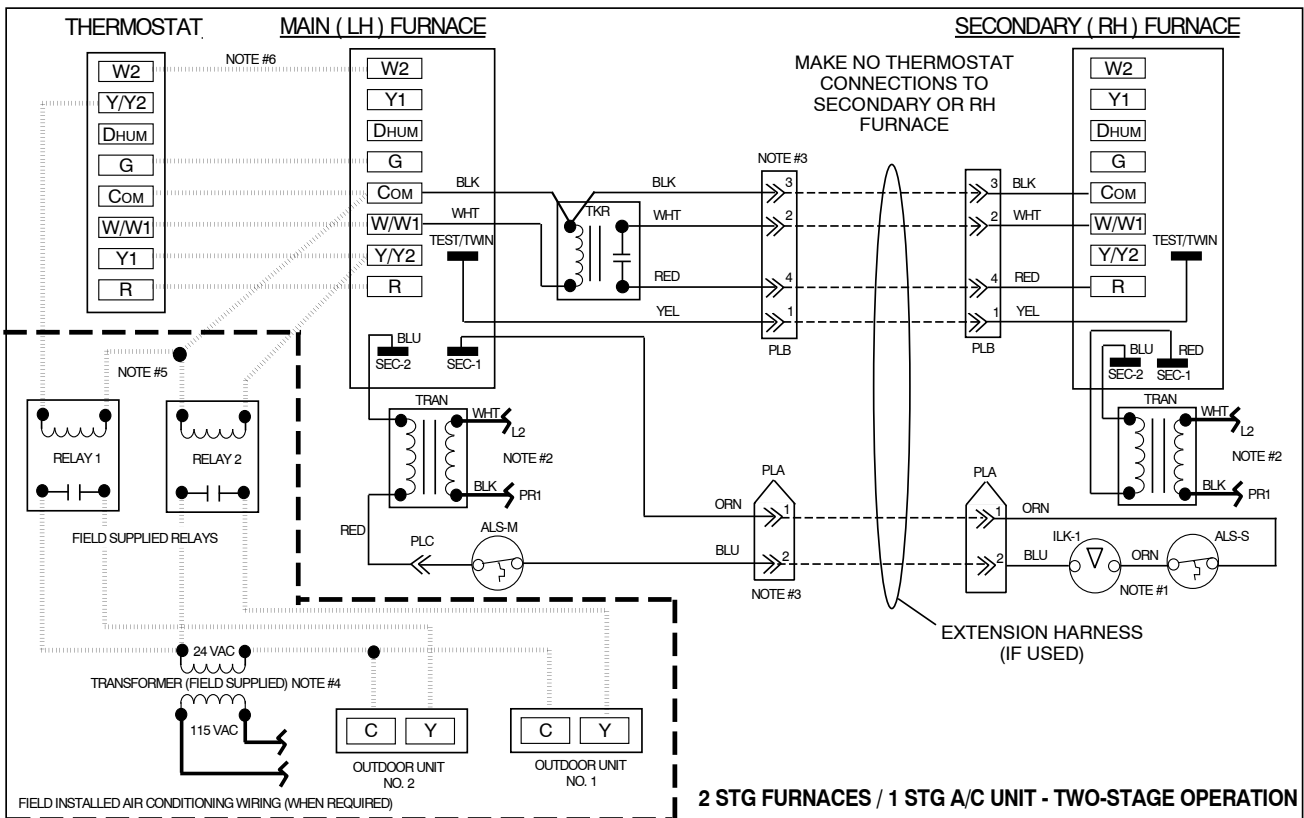

LEGEND:

- ACRDJ AIR CONDITIONING RELAY DISABLE JUMPER
- ALS-M MAIN AUX. LIMIT SW., OVERTEMP-MANUAL RESET, SPST - (N.C.)
- ALS-S SECONDARY AUX. LIMIT SW., OVERTEMP-MANUAL RESET, SPST - (N.C.)
- ILK-1 SECONDARY AUX. BLOWER DOOR INTERLOCK SWITCH, SPST - (N.O.)
- PLA 2-CIRCUIT TWINNING KIT CONNECTOR
- PLB 4 - CIRCUIT TWINNING KIT CONNECTOR
- PLC 1 - CIRCUIT TWINNING KIT IN-LINE SPLICE
- TEST/TWIN COMPONENT TEST & TWINNING TERMINAL
- TKR TWINNING KIT RELAY, SPST - (N.O.)
- TRAN TRANSFORMER - 115VAC / 24VAC (PART OF FURNACE)
- 115 VOLT WIRING
- TWINNING KIT EXTENSION HARNESS (REQUIRED)
- FIELD WIRING
- FACTORY WIRING (TWINNING KIT)

327891-101 REV. A

NOTES:

1. ALS-S and ILK-1 are located in the SECONDARY or RH furnace blower compartment.
2. Primary connections of transformer not shown; refer to furnace wire label.
3. When extension harness is not required PLA and PLB must be routed through holes in casings.
4. Transformer = 115 VAC primary / 24 VAC secondary / 40VA.
5. Relays = 24 VAC coils / pilot duty / normally open.
6. Two-stage heating can be accomplished by one of the two methods:
 - a. Using one stage thermostat and letting the Main Furnace (LH) algorithm control low and high-heat operation.
 - b. Using a two-stage thermostat to control low and high-heat operation. (Apply "W2" Wire)

	THERMOSTAT TYPE	LEFT HAND LHT SWITCH 1	RIGHT HAND LHT SWITCH 1									
<table border="1" style="font-size: 8px;"> <tr><td>LHT</td><td>OFF</td><td>ON</td></tr> <tr><td>OFF</td><td>ON</td><td>ON</td></tr> <tr><td>DLY</td><td>ON</td><td>ON</td></tr> </table>	LHT	OFF	ON	OFF	ON	ON	DLY	ON	ON	ONE STAGE THERMOSTAT	OFF	ON
LHT	OFF	ON										
OFF	ON	ON										
DLY	ON	ON										
	TWO STAGE THERMOSTAT	ON	ON									

Fig. 17 - Two-Stage Furnaces and 1-Stage A/C Unit - One or Two-Stage Thermostat

A02229

- a. Single-stage gas heating thermostat R-to-W operates both furnaces gas heat mode. First stage of a 2-stage thermostat causes LH furnace to operate in gas-heat mode. Second stage of a 2-stage thermostat causes both furnaces to operate in gas heat mode.
- b. Single stage thermostat operates first or second stage of a two stage furnace, based on the furnace control board algorithm. 2-stage heating thermostat R-to-W/W1 will operate both furnaces in low heat mode. Thermostat R

- to W/W1 and-W2 causes both furnaces to operate in high gas-heat mode.
- c. Thermostat R-to-G for continuous fan or low-cooling blower.
- d. Cooling thermostat R-to-G-and-Y for single-speed cooling blower.
8. Reinstall control doors on both furnaces.
9. Instruct user in operation of furnace and thermostat.

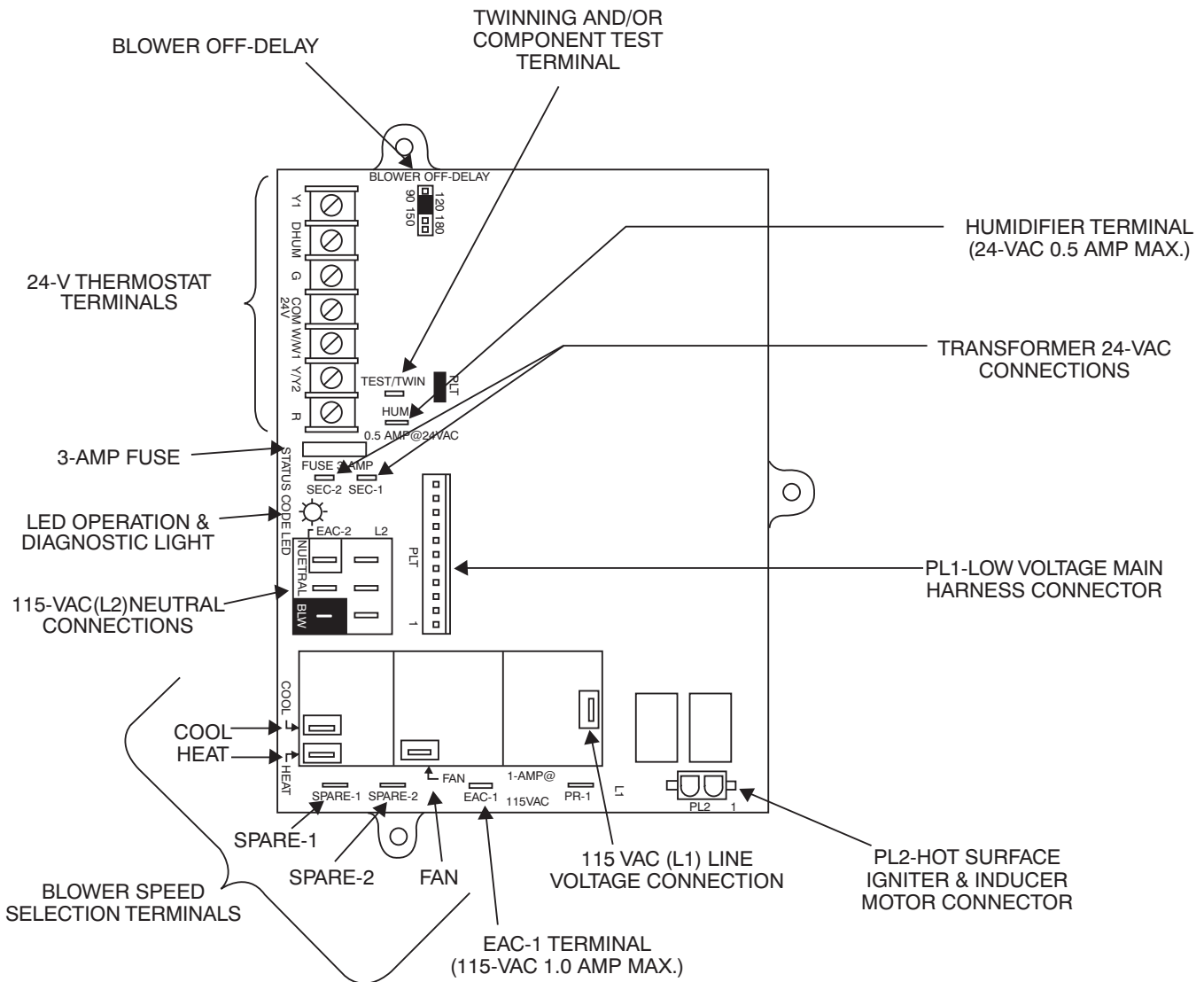

Fig. 18 - Single-Stage Furnace Control

A02142

PROCEDURE 8 — SEQUENCE OF OPERATION

See Fig. 15, 16, or 17 and 20 or 21 for single-speed non-condensing furnace twinning connection and schematic wiring diagrams while reviewing the sequence of operation.

Twinning operation is controlled by LH furnace. The TWIN/TEST and COM 24v connection wires ensure the 2 furnaces coordinate their blower operation. When either furnace requires blower operation, both furnaces operate their blowers at the same speed. Both furnaces operate simultaneously in the same mode: heat, cool, or continuous fan. Exceptions can occur if a safety switch on either

furnace is activated (such as pressure switch, flame roll-out switch, main limit switch, draft safeguard switch, twinning kit auxiliary limit switch, or flame-proving sensor). In such a case, the other furnace continues to operate unless open switch is the flame roll-out, main limit, or twinning kit auxiliary limit switch, in which case both furnaces respond.

Before performing component test, disconnect TKR yellow wire labeled TEST from LH furnace control TEST/TWIN terminal. After removing yellow wire, component test can be initiated on each furnace individually as stated in Installation, Start-Up, and Operating Instructions.

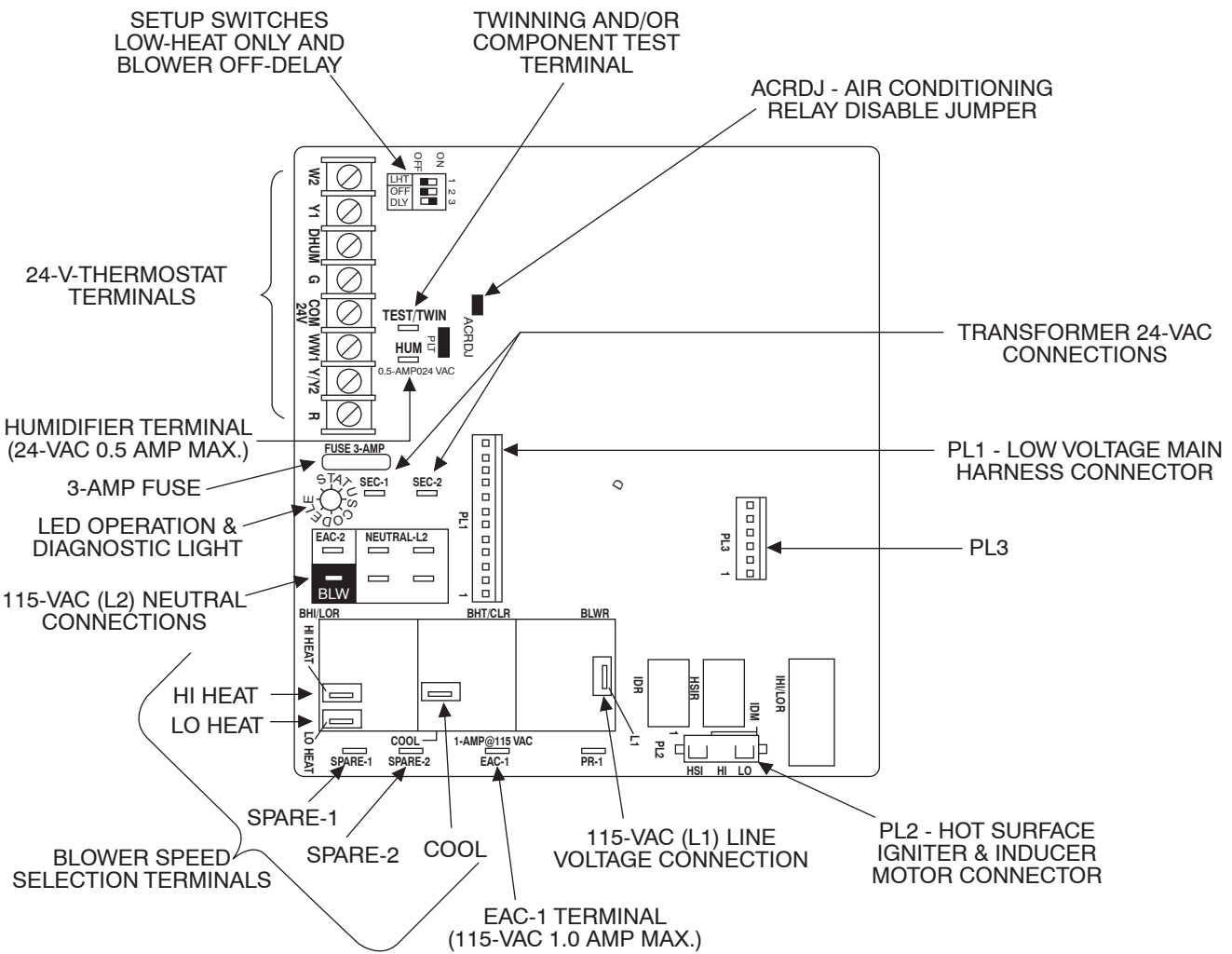

KGATW

Fig. 19 - Two-Stage Furnace Control

A02017

Single-Stage Heat with Single-Stage Gas-Heat Thermostat

See Section I, Procedure 2 for furnace and kit components used.

1. Single-stage thermostat causes both furnaces to operate in heating mode.
2. Operation in ALL modes is the same for twinned furnaces as for an individual furnace. See furnace Installation, Start-Up, and Operating Instructions for more information on sequence of operation.

Two-Stage Heat with 2-Stage Gas-Heat Thermostat

See Section I, Procedure 2 for furnace and kit components used.

1. The 2-stage thermostat causes the furnaces to operate in first-stage heat (LH furnace operates in heat while RH furnace blower operates but RH furnace is not heating) or causes the furnaces to operate in second-stage heat (both furnaces operate in heat), depending on whether 1 or 2 thermostat stages are calling for heat.
2. Operation in ALL modes is the same for twinned furnaces as for an individual furnace. See furnace Installation, Start-Up, and Operating Instructions for more information on sequence of operation.

SECTION II: SINGLE-SPEED AND TWO-SPEED MULTIPOISE CONDENSING HSI FURNACE MODELS

SINGLE STAGE				TWO-STAGE	
Model	Series	Model	Series	Model	Series
58MCA	170 and later series	340MAV	H and later series	58MTA	110 and later series
58MXA	160 and later series	350MAV	G and later series	58MTB	100 and later series
58MCB	100 and later series	PG9MAA	E and later series	352MAV	B and later series
58MXB	100 and later series	340AAV	A and later series	352AAV	A and later series
58MSA	140 and later series	350AAV	A and later series		
345MAV	E and later series	PG9MAB	A and later series		

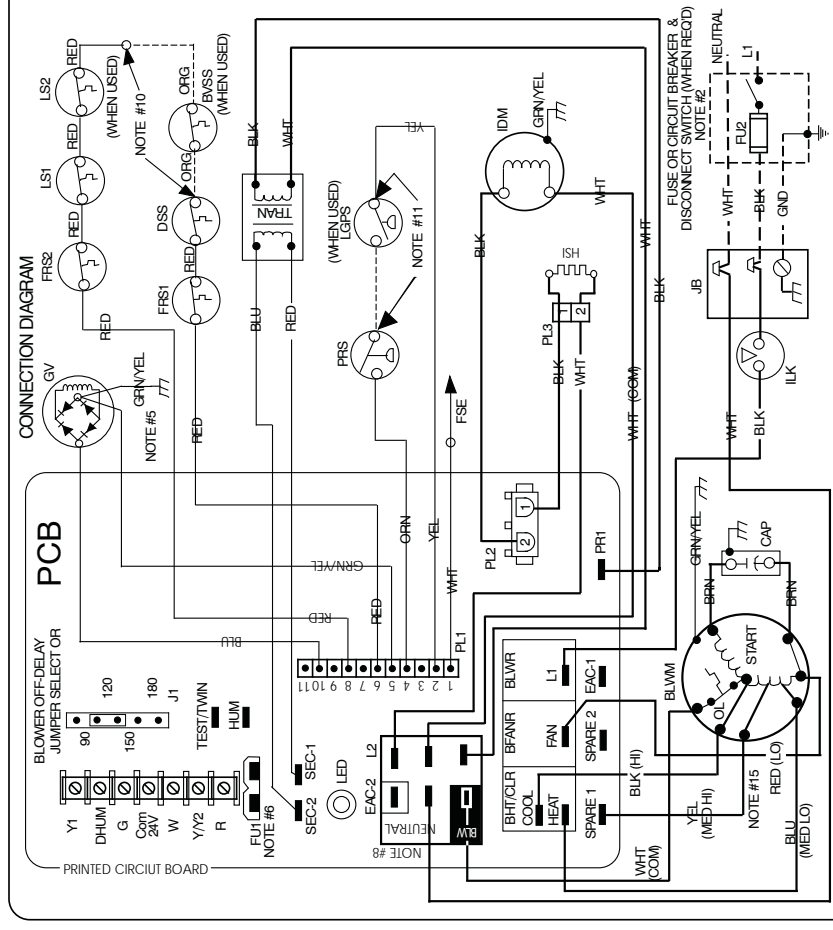

LEGEND

BFAN/R	CONTINUOUS-FAN SELECT RELAY; SPDT	LS1, 2	LIMIT SWITCH; AUTO-RESET; SPST (N.C.)
BHT/CLR	BLOWER MOTOR SPEED CHANGE RELAY; SPDT	OL	AUTO-RESET INTERNAL MOTOR OVERLOAD
BLWR	BLOWER MOTOR RELAY; SPST (N.O.)	PCB	TEMPERATURE SWITCH (N.C.)
BLWM	BLOWER MOTOR; PERMANENT-SPLIT-CAPACITOR	PL1	PRINTED CIRCUIT BOARD CONTROL
BVSS	BLOCKED-VENT SHUTOFF SWITCH; MANUAL-RESET; SPST (N.C.)	PL2	2-CIRCUIT PCB CONNECTOR
CAP	CAPACITOR	PL3	2-CIRCUIT HSI CONNECTOR
CPU	MICROPROCESSOR AND CIRCUITRY	PRS	PRESSURE SWITCH; SPST (N.O.)
DSS	DRAFT SAFE GUARD SWITCH; AUTO-RESET; SPST (N.C.)	TEST/TWIN	COMPONENT TEST & TWIN TERMINAL
EAC-1	ELECTRONIC AIR CLEANER CONNECTION (115 VAC/1.0 AMP MAX.)	TRAN	TRANSFORMER; 115VAC/24VAC
EAC-2	ELECTRONIC AIR CLEANER CONNECTION (COMMON)		
FRS 1, 2	FLAME ROLLOUT SW. - MANUAL RESET; SPST (N.C.)		
FU 1	FLAME-PROVING ELECTRODE		
FU 2	FUSE; 3 AMP AUTOMOTIVE BLADE TYPE; FACTORY INSTALLED		
GND	FUSE OR CIRCUIT BREAKER CURRENT INTERRUPT DEVICE (FIELD INSTALLED & SUPPLIED)		
GVR 1, 2	EQUIPMENT GROUND		
HSI	GAS VALVE REDUNDANT		
HUM	HOT SURFACE IGNITER (115 VAC)		
IDM	HOI SURFACE IGNITER RELAY; SPST (N.O.)		
ILK	24VAC DRIFT MOTOR SELECTOR (0.5 AMP MAX.)		
J1	INDUCED DRAFT MOTOR SELECTOR (0.5 AMP MAX.)		
J2	INDUCED DRAFT MOTOR RELAY SPST (N.O.)		
J3	BLOWER ACCESS PANEL INTERLOCK SWITCH; SPST (N.O.)		
J4	BLOWER DELAY JUMPER SELECTOR		
LED	JUNCTION BOX		
LGPS	LOW GAS PRESSURE SWITCH; SPST (N.O.)		

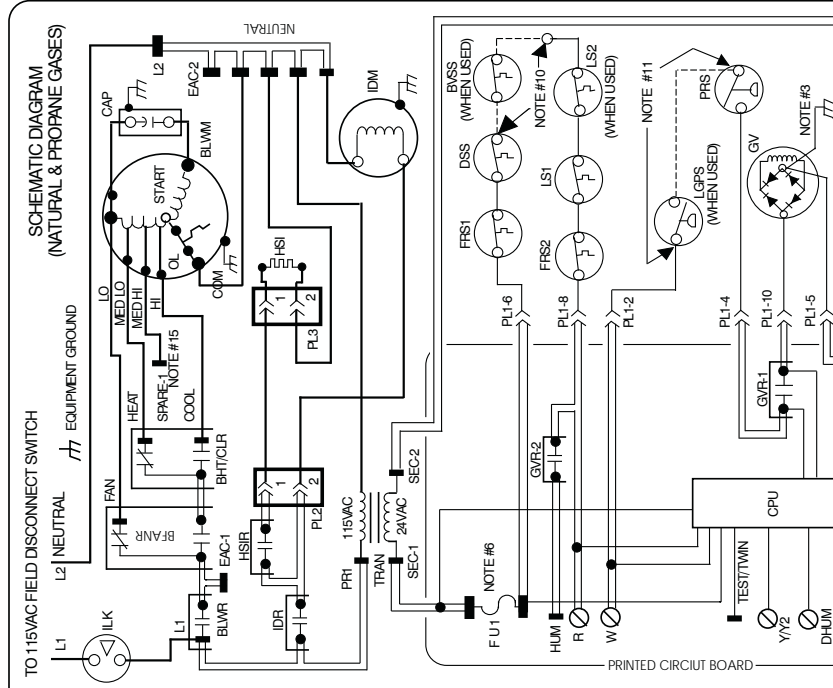

- NOTES:**
- If any of the original equipment wire is replaced use wire rated for 105°C.
 - Use only copper wire between the disconnect switch and the furnace junction box (JB).
 - This wire must be connected to turnace sheet metal for control to prove flame.
 - Symbols are electrical representation only.
 - Solid lines inside PCB are printed circuit board conductors and are not included in legend.
 - Replace only with a 3 amp fuse.
 - Inducer (IDM) and blower (BLWM) motors contain internal auto-reset thermal overload switches (OL).
 - Neutral connections are interchangeable within the NEUTRAL connector block.
 - Blower motor speed selections are for average conditions, see installation instructions for details on optimum speed selection.
 - Factory connected when BVSS (Chimney Adapter Accessory Kit) is not installed.
 - Ignition-lockout will occur after four consecutive unsuccessful trials-for-ignition. Control will auto-reset after three hours.
 - Blower-on delay; gas heating selections are 90, 120, 150 or 180 seconds, cooling or heat pump 90 seconds or 5 seconds when DHUM is ON.
 - YELLOW lead not on all motors.

327560-101 REV. D

Fig. 20 - Wiring Diagram for Fixed-Capacity, Non-Condensing Furnaces

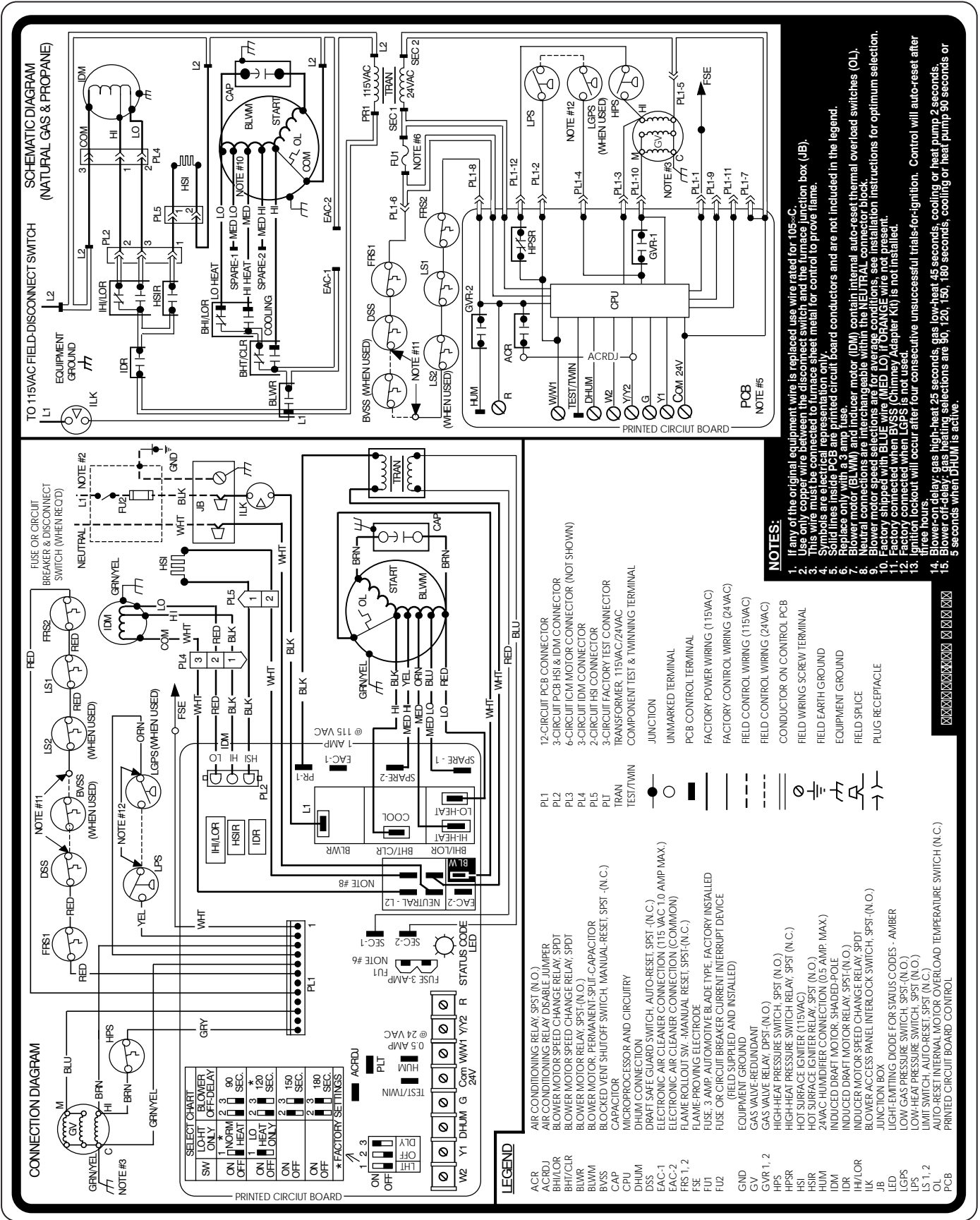
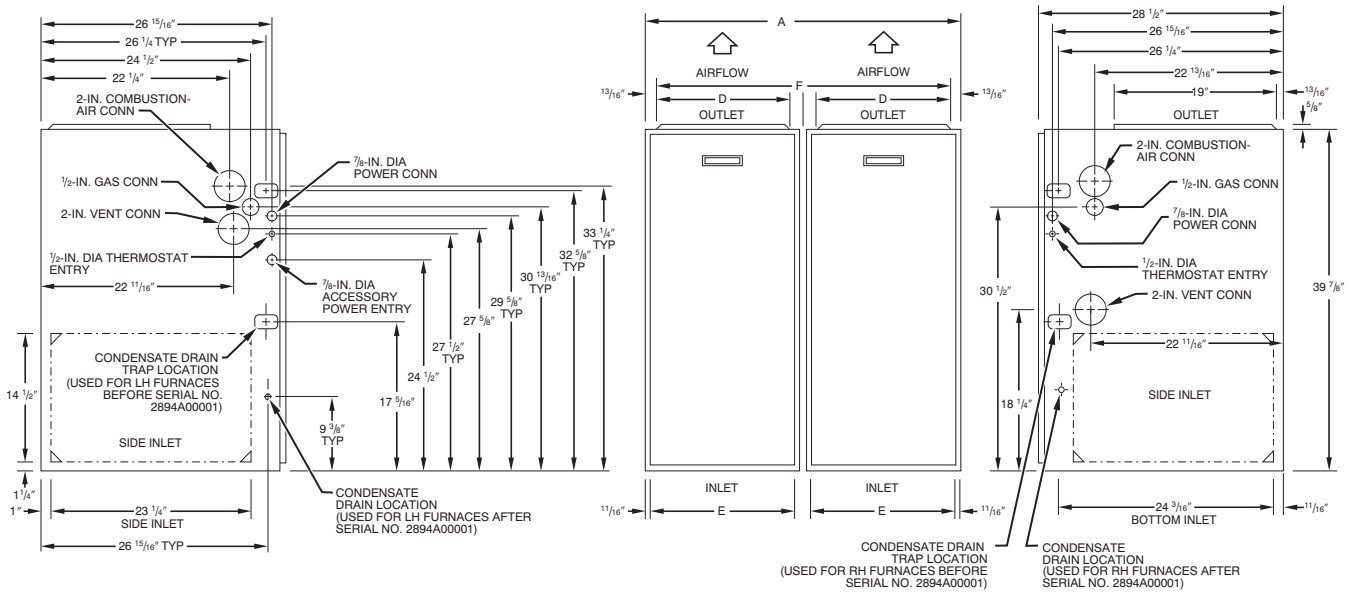

Fig. 21 - Wiring Diagram for Two-Stage, Non-Condensing Furnaces

A02159



A93537

Fig. 22 - Dimensional Drawing for Twinned Single-Speed Condensing Furnaces (Upflow, Downflow)

**Table 3 – 58MCA, 58MCB, 58MSA, 58MTB, 58MXA, 58MXB, 58MTZ, 340AAV, 340MAV, 345MAV, 350AAV, 350MAV, 352AAV, 352MAV, 490AAV, PG9MAA and PG9MAB
Single-Speed Condensing Furnace Dimensions - In. (mm)**

INPUT HEATING SIZE (BTUH)	NOMINAL COOLING SIZE	A	D	E	F
60,000	48,000	35 (889)	15-7/8 (403)	16 (406)	33-3/8 (848)
80,000*	48,000	35 (889)	15-7/8 (403)	16 (406)	33-3/8 (848)
80,000	60,000	42 (1067)	19-3/8 (492)	19-1/2 (495)	40-3/8 (1026)
100,000*	48,000	42 (1067)	19-3/8 (492)	19-1/2 (495)	40-3/8 (1026)
100,000*	60,000	42 (1067)	19-3/8 (492)	19-1/2 (495)	40-3/8 (1026)
120,000*	60,000	49 (1245)	22-7/8 (581)	23 (584)	47-3/8 (1203)

*Two-speed furnace capacities and dimensions

PROCEDURE 1 — INSTALL FURNACES

NOTE: Multipoise units can be installed in UPFLOW, DOWNFLOW, or HORIZONTAL configurations.

A. Upflow, Downflow, Side-By-Side Configuration

Refer to Fig. 22 for appearance and dimensional drawing of twinned furnaces and their connection locations.

1. Select 2 identical heating and airflow furnaces. (See Table 3.)
2. Remove bottom closure panels from both furnaces. (See Fig. 21.)
 - a. Remove main and blower access doors.
 - b. Remove 2 screws from front filler panel.
 - c. Rotate front filler panel downward to remove.
 - d. Remove bottom closure panel and discard.
 - e. Reinstall front filler panel.
3. Apply 2 factory-supplied foam strips to mating side of each furnace. Locate strips equal distance from top and bottom as shown in Fig. 25.
4. Return air connections
 - a. For upflow applications: Bottom return air usage is required as part of any upflow return air configuration. If additional return air is to enter 1 side of each furnace, in addition to bottom return air, cut open 1 entire return-air opening in appropriate side of each furnace. (See Fig. 1.)

⚠ WARNING

UNIT DAMAGE AND FIRE HAZARD

Failure to follow this warning could result in unit damage, fire, personal injury or death.

DO NOT use the back of the furnace for return-air duct connections as limit cycling will occur.

- b. For downflow applications: Return air can only be connected to bottom opening of furnace. A common return air plenum is required for proper auxiliary limit switch operation. (See Fig. 2.)
5. For upflow applications
 - a. Position furnaces against each other on return-air plenum. Adjust and shim each furnace to align unused condensate drain line holes in lower section of both furnaces holes, which will be used for wire routing between furnaces. (See Fig. 31.)
 - b. Drill two 1/8-in. holes, approximately 1 in. (25 mm) below discharge air flange, from inside top of discharge opening and through both furnaces. (See Fig. 26.)
 - c. Drive 1 factory-supplied No. 6 X 3/4-in. LG screw through each hole and tighten until furnaces are secure and foam strips have sealed gap between furnaces.

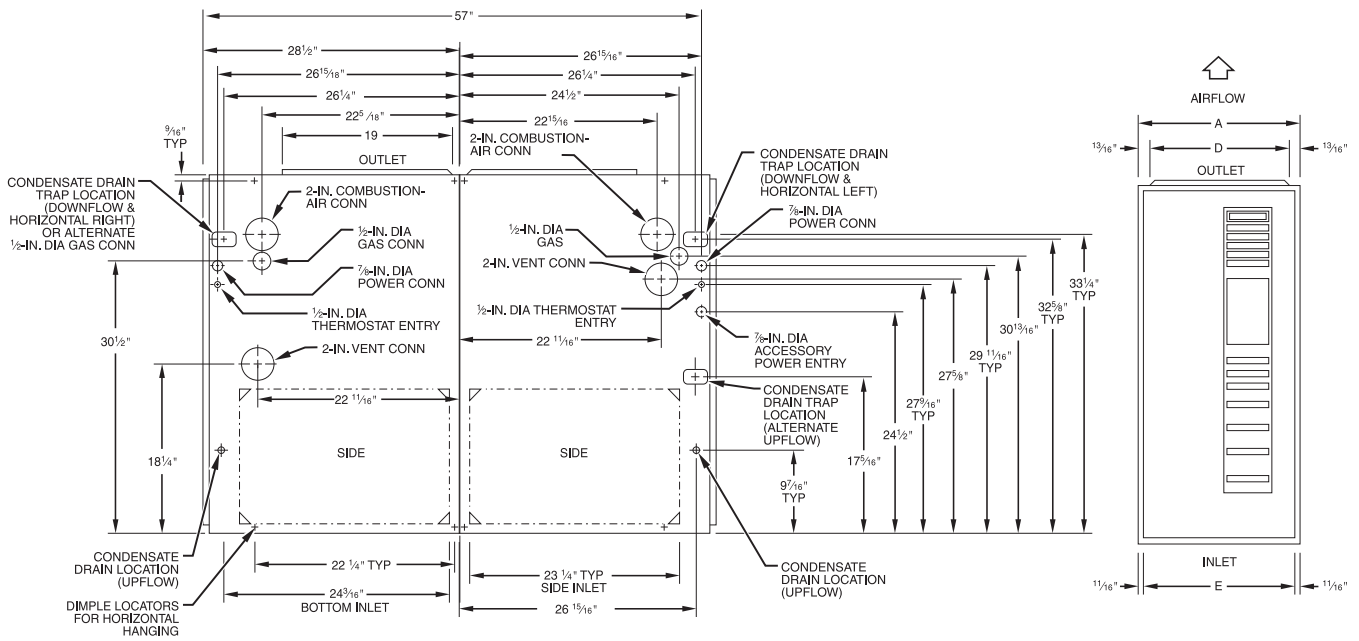

Fig. 23 - Back-to-Back (Upflow, Downflow or Horizontal)

A02234

Table 4 – Dimensions - In. (mm)

INPUT HEATING SIZE (BTUH)	NOMINAL COOLING SIZE	A	D	E	TWINNED FURNACE WEIGHT LBS (kg)
60,000	48,000	17-1/2 (445)	15-7/8 (403)	16 (406)	350 (159)
80,000*	48,000	17-1/2 (445)	15-7/8 (403)	16 (406)	410 (186)
80,000	60,000	21 (533)	19-3/8 (492)	19-1/2 (495)	228 (103)
100,000*	48,000	21 (533)	19-3/8 (492)	19-1/2 (495)	458 (208)
100,000*	60,000	21 (533)	19-3/8 (492)	19-1/2 (495)	464 (210)
120,000*	60,000	24-1/2 (622)	22-7/8 (581)	23 (584)	522 (237)

*Two-Speed furnace capacities and dimensions

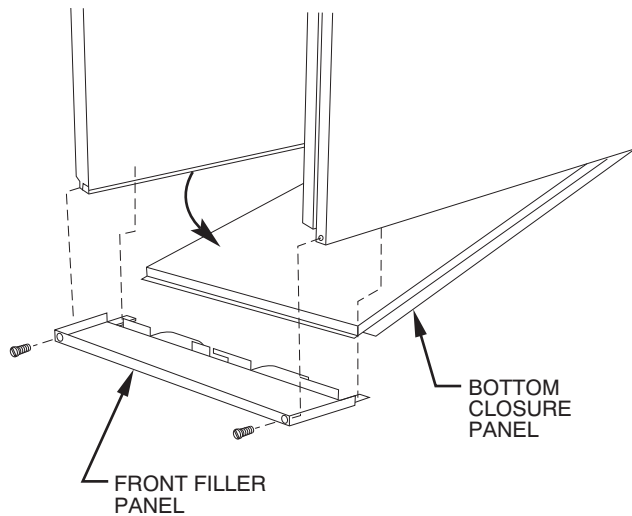

Fig. 24 - Bottom Closure Panel

A93047

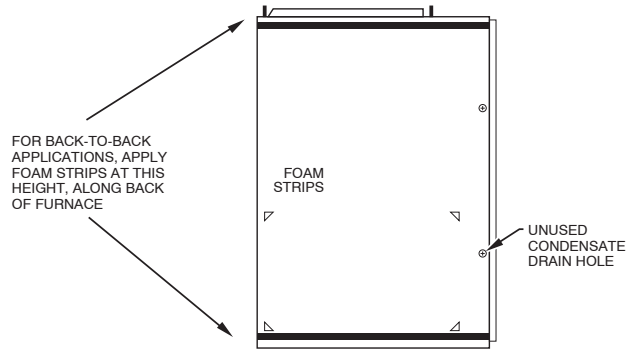

Fig. 25 - Location of Foam Strips and Hole to be used for Twinning Kit Wire Routing

A02236

KGATW

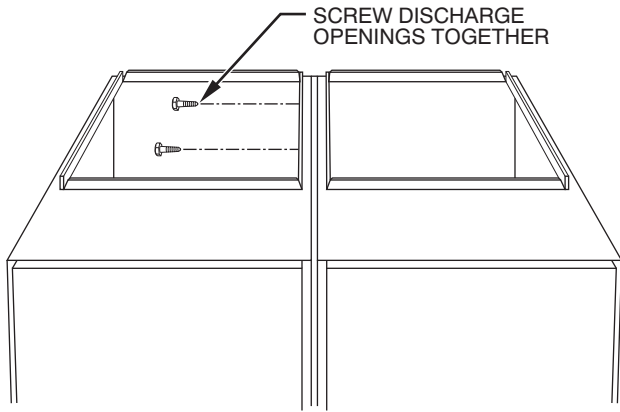

Fig. 26 - Attaching Furnaces Together

A93539

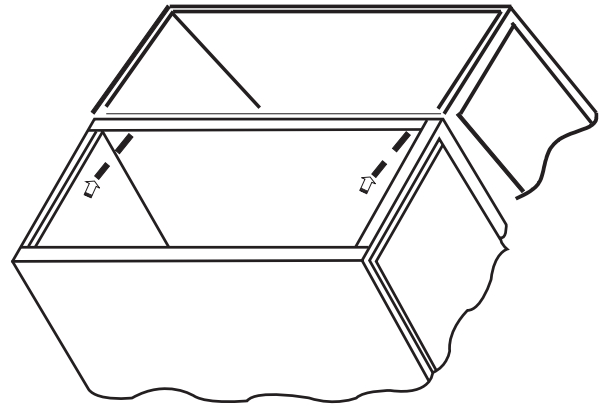

Fig. 27 - Attaching Furnaces Together - Downflow

A02219

6. For downflow applications:
 - a. Position furnaces on downflow kits (no A/C coils) or on entering air-side of A/C coils. Adjust and shim each furnace to align unused condensate drain line holes in lower section of both furnaces holes, which will be used for wire routing between furnaces. (Similar to Fig. 31.)
 - b. Drill two 1/8-in. holes, approximately 1 in. (25 mm) below return air flange, from inside top of return air opening and through both furnaces. (See Fig. 27.)
 - c. Drive 1 factory-supplied No. 6 X 3/4-in. LG screw through each hole and tighten until furnaces are secure and foam strips have sealed gap between furnaces.
7. Insert 1 snap bushing through each adjoining unused condensate drain line hole of each furnace.
8. Connect return- and supply-air ducts to furnaces. Seal duct connections to prevent air leakage.
9. 115-V junction boxes JB must be located on right side of right-hand furnace and left side of left-hand furnace. Relocate as necessary. (See Fig. 31.)
10. Follow individual furnace installation instructions for upflow/downflow applications. This includes, but not limited to: condensate trap, condensate/inducer housing tubing, pressure switch tubing venting and electrical connections.

- c. Rotate front filler panel downward to remove.
 - d. Remove bottom closure panel and discard.
 - e. Reinstall front filler panel.
3. Apply 2 factory-supplied foam strips to mating back of each furnace. Locate strips equal distance from top and bottom as shown in Fig. 25. Trim off excess material.
4. Return Air Connections
 - a. For upflow applications: Bottom return air usage is required as part of any upflow return air configuration. If additional return air is to enter 1 side of each furnace, in addition to bottom return air, cut open 1 entire return-air opening in appropriate side of each furnace. (See Fig. 1.)

⚠ WARNING

UNIT DAMAGE AND FIRE HAZARD

Failure to follow this warning could result in unit damage, fire, personal injury or death.

DO NOT use the back of the furnace for return-air duct connections as limit cycling will occur.

⚠ WARNING

UNIT DAMAGE AND FIRE HAZARD

Failure to follow this warning could result in unit damage, fire, personal injury or death.

DO NOT use the back of the furnace for return-air duct connections in upflow position, as limit switch cycling will occur.

B. Upflow/Downflow, Back-to-Back Configuration

Refer to Fig. 23 and Table 4 for appearance and dimensional drawing of twinned furnaces and their connection locations.

1. Select 2 identical heating and airflow furnaces. (See Table 4.)
2. Remove bottom closure panels from both furnaces. (See Fig. 24.)
 - a. Remove main and blower access doors.
 - b. Remove 2 screws from front filler panel.

- b. For downflow applications: Return air can only be connected to bottom opening of furnace. A common return air plenum is required for proper auxiliary limit switch operation. (See Fig. 2.)
5. For upflow applications
 - a. Position furnaces against each other on return-air plenum. (See Fig. 23.)
 - b. Drill two 1/8-in. holes, approximately 1 in. (25 mm) below discharge air flange, from inside top of discharge opening and through both furnaces. (See Fig. 27.)
 - c. Drive 1 factory-supplied No. 6 X 3/4-in. LG screw through each hole and tighten until furnaces are secure and foam strips have sealed gap between furnaces.
6. For downflow applications
 - a. Position furnaces on downflow kits or plenum (no A/C coils) or on entering air-side of A/C coils. (See Fig. 23.)
 - b. Drill two 1/8-in. holes, approximately 1 in. (25 mm) below return air flange, from inside top of return air opening and through both furnaces. (See Fig. 27.)

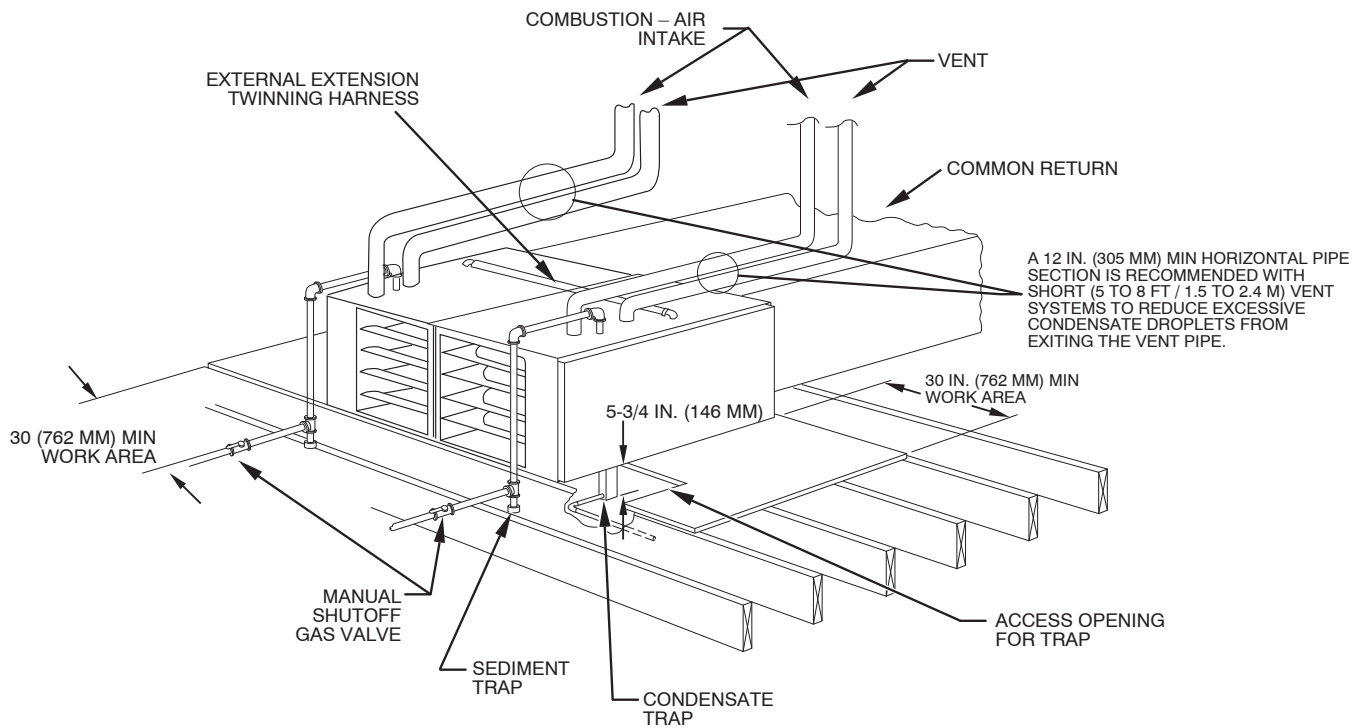

A02209

Fig. 28 - Attic Installation on a Platform

- c. Drive 1 factory-supplied No. 6 X 3/4-in. LG screw through each hole and tighten until furnaces are secure and foam strips have sealed gap between furnaces.
- 7. Determine which side of furnace will be used to route external extension harness. If condensate drain hole is available, use it, otherwise, drill two 7/8-in holes in blower housing area, mid-point between blower deck and bottom of furnace.

NOTE: The external extension harness cannot be used on the same side of the furnace that the return air ducts connect to. Locate harness on opposite side of furnace where return air is used.

- 8. Connect return and supply-air ducts to furnaces. Seal duct connections to prevent air leakage.
- 9. Follow individual furnace installation instructions for up-flow/downflow applications. This includes, but not limited to: condensate trap, condensate/inducer housing tubing, pressure switch tubing venting and electrical connections.

C. Horizontal, Back-to-Back Configuration

When twinning furnaces in the horizontal position, consideration must be made to the type of building construction. Attic floors should be constructed to support normal live and dead loads of the furnaces and the person(s) servicing them. Trusses, wood and metal are engineered for specific applications, and may not support the weight of two (2) furnaces suspended from the top chords or the bottom chords of the trusses. Long horizontal spans may flex or sag, resulting in damage to the building. Contact the truss manufacturer for additional design and engineering assistance.

Do not suspend furnaces with straps or suspend furnaces from roof decking.

For attic installations on a platform:

- 1. Construct a platform from 3/4-in. (nominal plywood), extending out 30 inches (762 mm) from the front of each furnace. (See Fig. 28.)
- 2. Maintain all clearances to combustibles per the furnace Installation, Start-up and Operating Instructions.
- 3. Follow all additional building codes.

- 4. Long truss spans may require additional support along the bottom chord of the truss. Consult the truss manufacturer's guidelines for engineering assistance.
- 5. Long rafter or attic joist spans may require additional support along the bottom of the rafter or joist. Consult local or regional building codes for design and loading requirements.

For suspended installations (Not recommended for wood trusses) (See Fig. 29.):

- 1. Furnaces may be suspended using two (2) pieces of 1-1/2-in. x 1-1/2-in. x 1/4-in. thick cold rolled angle iron underneath each furnace and four (4) 3/8-in. diameter threaded rods.
- 2. Allow for at least 8 inches (203 mm) in front of each door for door removal.
- 3. Each piece of angle iron must be secured to the bottom of each furnace with at least two (2) #8 x \square sheet metal screws.
- 4. Maintain all clearances to combustibles per the furnace Installation, Start-up and Operating Instructions.
- 5. Unistrut or similar material may be used, provided that the furnaces do not sag in the middle or bend or twist at the support ends. The support material must be secured to the bottom of each furnace in a manner similar to securing angle iron to the furnace.

Refer to Fig. 23 and Table 4 for appearance and dimensional drawing of twinned furnaces and their connection locations.

- 1. Select 2 identical heating and airflow furnaces. (See Table 4.)
- 2. Remove bottom closure panels from both furnaces. (See Fig. 24.)
 - a. Remove main and blower access doors.
 - b. Remove 2 screws from front filler panel.
 - c. Rotate front filler panel downward to remove.
 - d. Remove bottom closure panel and discard.
 - e. Reinstall front filler panel.

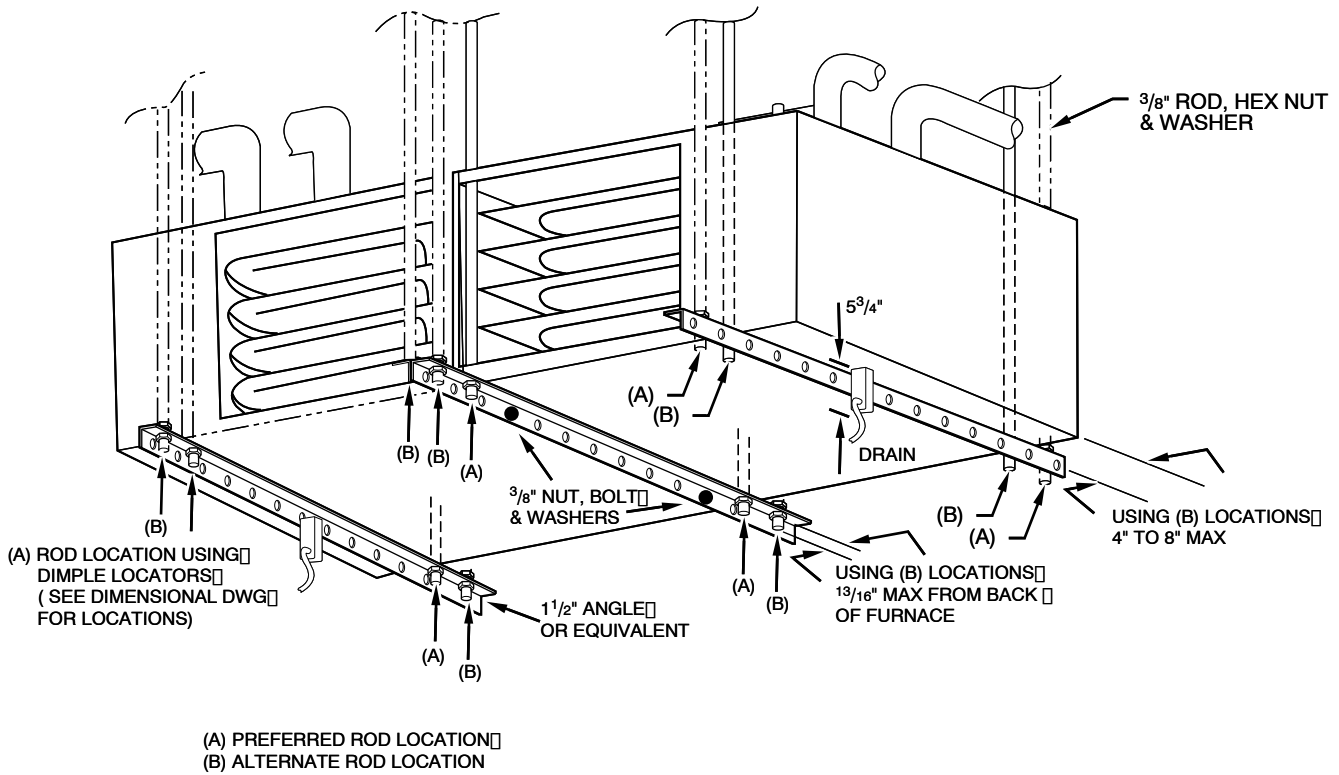

Fig. 29 - Suspended Installation of Furnaces

A02208

3. Apply 2 factory-supplied foam strips to mating back of each furnace. Locate strips equal distance from top and bottom as shown in Fig. 25. Trim off excess material.
4. Securing furnaces together:
 - a. Lay furnaces back-to-back on a flat surface.
 - b. Similar to side-by-side installations (See Fig. 26.), drill two 1/8-in. holes, approximately 1 in. (25 mm) below discharge air flange, from inside top of discharge opening and through both furnaces. Also drill two 1/8-in. holes, approximately 1 in. (25 mm) below return air flange, from inside top of return air opening and through both furnaces.
 - c. Drive 1 factory-supplied No. 6 X 3/4-in. LG screw through each hole and tighten until furnaces are secure and foam strips have sealed gap between furnaces.
5. With furnaces laying in their side and back-to-back, determine which side will now be the top side to route external extension harness. Use the unused condensate drain holes in blower housing area.
6. Connect return- and supply-air ducts to furnaces. Seal duct connections to prevent air leakage.
7. Follow individual furnace installation instructions for horizontal applications. This includes, but not limited to: condensate trap, condensate/inducer housing tubing, pressure switch tubing venting and electrical connections.

PROCEDURE 2 — CONNECT ELECTRICAL COMPONENTS—HEATING

⚠ WARNING

FIRE HAZARD
 Failure to follow this warning could result in fire, personal injury or death.
 Make no connections between the R 24-vac connector in 1 furnace and the R 24-vac connector in other furnace.

See Electrostatic Discharge Precaution Section.

NOTE: To determine referencing of Left Hand (LH) and Right Hand (RH) furnace:

- a. In the Side-by-Side, upflow and downflow applications, reference the furnaces from the front, as you would see them in the upflow application (See Fig. 31.) The LH furnace is the main furnace and the RH furnace is the secondary furnace.
- b. In the Back-to-Back, upflow, downflow and horizontal applications, reference the furnaces from the side of the external extension harness. The LH furnace is the main furnace and the RH furnace is the secondary furnace, as you would see them in the upflow application (See Fig. 32.)

There are 3 harnesses included in this kit. If the furnaces are side-by-side, only 2 harnesses are required. If the furnaces are installed back-to-back, all 3 harnesses included in the kit must be used.

1. Remove outer doors and blower access doors from both furnaces.

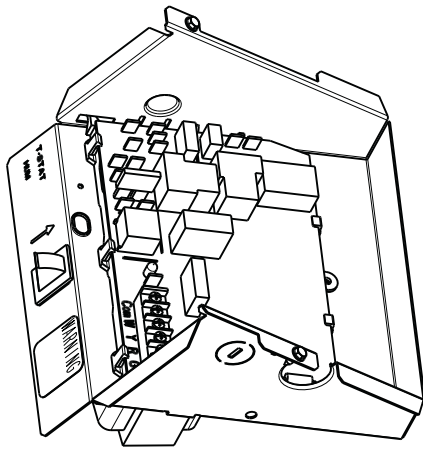

A02226

Fig. 30 - Twinning Kit Relay Mounted on Control Mounting Bracket for LH Furnace

2. If furnaces are installed back-to-back in any orientation, the External Extension Harness must be used. The harness consists of:
 - a. 54-1/2 inches (1384 mm) of 1/2-in. flexible steel conduit
 - b. (2) 90° conduit connectors
 - c. (3) 4 wire polarized wiring harness
 - d. (3) 2 wire polarized wiring harness

Install the harness as follows:

- a. Remove lock nuts from the end of each conduit connector.
 - b. Route the end of the harness that mates to the TKR relay harness of the LH furnace through the unused condensate trap hole in the casing of the blower compartment.
 - c. Route the end of the harness that mates to the 4-wire harness of the RH furnace through the unused condensate trap hole in the casing of the blower compartment.
 - d. Install the lock nuts on the 90° conduit connectors.
 - e. Install the two kit-supplied straps approximately 18 inches (457 mm) from each end of extension harness.
3. Fixed Capacity Furnace/Single-Stage Heat with Single-Stage Gas-Heat Thermostat (Field Supplied) OR Two-Stage Furnace with Single or Two-Stage Gas-Heat Thermostat (Field-Supplied)

NOTE: This application of TKR allows both furnaces to operate as 1 furnace gas heat mode as determined by an individual thermostat. Install twinning kit relay (TKR):

- a. Mount TKR assembly to underside of LH furnace control enclosure using 1 No. 6 sheet metal screw (factory supplied). Screw hole is located to left of door switch near front edge of control. (See Fig. 30.)

NOTE: See Fig. 15 or 17 for twinning kit wiring.

- b. Route 3 loose wires (black, yellow, and white) from TKR assembly wire harness through T-STAT/HUM hole adjacent to door switch. (See Fig. 30.)
 - c. Connect TKR white wire labeled W from TKR to LH furnace control thermostat connection W or W/W1.
 - d. Connect TKR black wire labeled C from TKR to LH furnace control thermostat connection COM 24V.
 - e. Connect yellow wire labeled TEST to LH furnace control TEST/TWIN terminal.
 - f. Route female four-pin connector end of TKR wires:
 - (1.) For Side-by-Side applications, see Fig. 22 and 31. Route female, four-pin connector through previously installed bushings in unused condensate drain holes, located on casing in blower compartment area. Connect to male four-pin connector of RH furnace.
 - (2.) For Back-to-Back applications, see Fig. 23 and 32. Connect the female, four pin connector to the male four pin connector of the previously installed External Extension Kit. Connect the female four pin connector of the External Extension Kit to the male four pin connector of the RH furnace.
 - g. Route four wires through thermostat cable hole of RH furnace control box.
 - h. Connect TKR red wire labeled R-SECONDARY from TKR to RH furnace control thermostat connection R.
 - i. Connect TKR white wire labeled W-SECONDARY from TKR to RH furnace control thermostat connection W or W/W1.
 - j. Connect TKR black wire labeled C-SECONDARY from TKR to RH furnace control thermostat connection COM 24V.
 - k. Connect yellow wire labeled TEST SECONDARY from LH furnace control TEST/TWIN terminal to RH furnace control TEST/TWIN terminal.
1. **For Two-Stage Furnace Control Boards**—In addition to the wiring of the twinning kit, the LHT switch and a single OR two-stage gas-heat thermostat must be configured to one of the two methods describe below:

Two-Stage Heat with Single-Stage Gas-Heat Thermostat (allows the LH or Main Furnace’s algorithm control low and high-heat operation)

 - (1.) Position LHT switch on Main or LH furnace control to OFF.
 - (2.) Position LHT switch on Secondary or RH furnace control to ON.

Two-Stage Heat with Two-Stage Gas-Heat Thermostat (allows a two-stage thermostat to control low and high-heat operation)

Position LHT switch furnace controls in BOTH furnaces to ON
- m. Proceed to #5 “Install LH furnace auxiliary limit switch harness ALS-M” to complete electrical connections.

KGATW

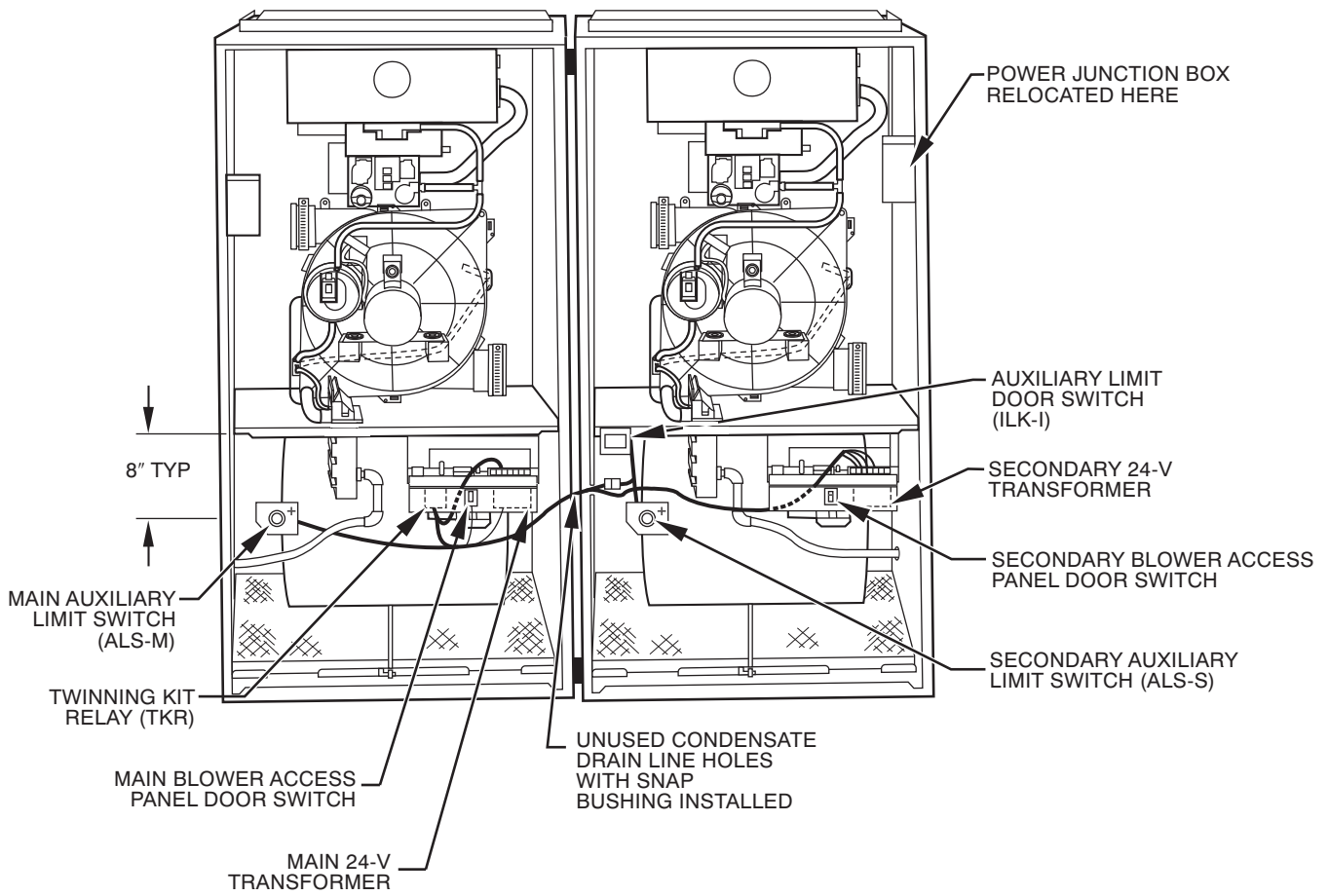

Fig. 31 - Twinning Kit Installed on Single-Speed and 2-Stage Condensing Furnaces (After Serial No. 2894A00001) Single-Speed Shown

A01377

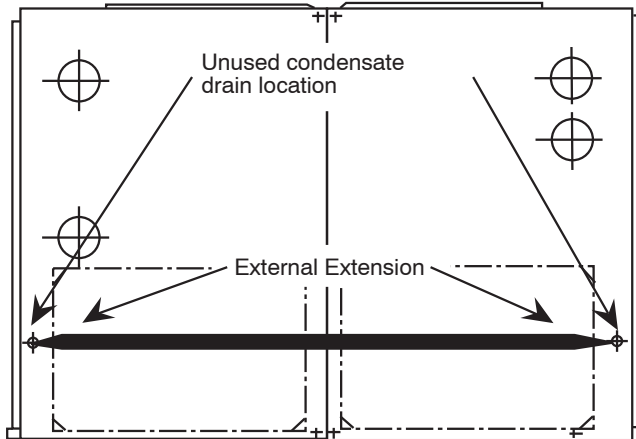

Fig. 32 - External Extension Harness (Back-to-Back Application)

A02225

4. Two-Stage Heating using Fixed-Capacity Furnaces with Two-Stage Gas Heat Thermostat (Field Supplied). See Fig. 16.

NOTE: This modification allows LH furnace only to operate in heating mode for first-stage heat or both furnaces to operate in heating mode for second-stage heat as determined by a 2-stage thermostat. See furnace Installation, Start-Up, and Operating Instructions for further details on this heating mode.

To operate furnaces in 2-stage heating mode when a 2-stage thermostat controls the staging, install twinning kit as described above, then modify TKR wiring as follows:

⚠ CAUTION

PERSONAL INJURY HAZARD

Failure to follow this caution may result in intermittent furnace operation and unit damage.

Supply-air temperature will be uneven left-to-right when only main system is operating.

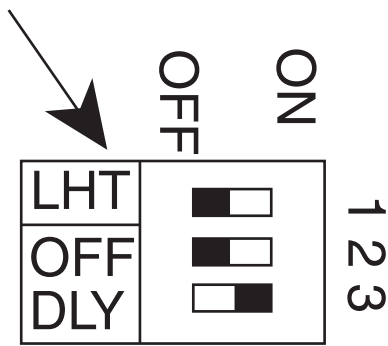

Thermostat Type	MAIN or Left Hand LHT Switch 1	MAIN or Right Hand LHT Switch 1
LH Furnace Algorithm	OFF	ON
Two Stage Thermostat	ON	ON

A02237

Fig. 33 - LHT Switches

NOTE: See Fig. 16.

- a. Disconnect TKR white wire labeled W from LH furnace control thermostat connection W.
- b. Cut terminal off TKR white wire labeled W and strip 1/4 in. (6 mm).
- c. Connect 2-stage thermostat W2 connection to TKR white wire labeled W.

NOTE: ALL other 2-stage thermostat connections are to be made to LH furnace control center ONLY.

- d. Proceed to #5 "Install LH furnace Auxiliary Limit Switch - Main ALS-M" harness to complete electrical connections.
5. Install LH furnace (main) auxiliary limit switch harness ALS-M.

NOTE: LH furnace ALS-M assembly DOES NOT include door switch.

- a. Drill 1/8-in. hole in blower housing 8 in. below blower shelf as shown in Fig. 31.
- b. Position ALS-M so reset button faces front of furnace.
- c. Secure bracket to blower housing using factory-supplied No. 6 X 3/4-in. LG screw.
- d. Disconnect red transformer wire from SEC-1 connection.
- e. Connect removed red transformer wire to ALS-M wire connector labeled TRAN. Route through thermostat holes of control box.
- f. Connect ALS-M connector labeled SEC 1 to LH furnace control SEC-1 terminal.
- g. Route 2-wire ALS-M connector from LH furnace to RH furnace through unused condensate drain line hole with snap bushing.
6. Install RH furnace (SECONDARY) auxiliary door switch and harness (ALS-S/ILK-1).

NOTE: RH furnace ALS-S assembly HAS door switch included.

- a. Install auxiliary limit switch (ALS-S).
 - (1.) Drill 1/8-in. hole in blower housing 8 in. below blower shelf as shown in Fig. 25.
 - (2.) Position ALS-S so terminals face front of furnace.
 - (3.) Secure bracket to blower housing using factory-supplied No. 6 X 3/4-in. LG screw.
- b. Install auxiliary door switch (ILK-1).

- (1.) Drill 7/32-in. hole in left side of RH furnace blower shelf for mounting door switch as shown in Fig. 31.
- (2.) Secure ALS-S door switch (ILK-1) using factory-supplied flat screw No. 6 X 3/4-in. LG screw.
- c. Connect RH furnace 2-wire ALS-S connector PL6 to LH furnace 2-wire ALS-M connector PL6 that was routed through furnace casings.
7. Select identical blower speed taps at blower motor connections on control center in both furnaces.

KGATW

⚠ CAUTION

UNIT DAMAGE HAZARD

Failure to follow this caution could result in unit damage.

Failure to select identical blower speed taps in both furnaces can result in overheating of furnace components and possible loss of furnace operation and damage to the furnace.

8. Dress wires to ensure they do not contact sharp edges or moving parts, nor interfere with blower operation, removal of filters, or operation of switches.
9. Make all thermostat connections to the LH furnace only.

PROCEDURE 3 — CONNECT ELECTRICAL COMPONENTS—COOLING

⚠ WARNING

ELECTRICAL OPERATION HAZARD

Failure to follow this warning could result in unit damage, fire, personal injury or death.

Make no connections between the R 24-vac connector in 1 furnace and the R 24-vac connector in other furnace.

When installing twinned outdoor units with twinned gas furnaces, it is necessary to use a field-supplied 24-vac pilot-duty relay and a field-supplied 24/115-vac transformer as shown in Fig. 15, 16, or 17 to prevent overloading furnace 24/115-vac transformer.

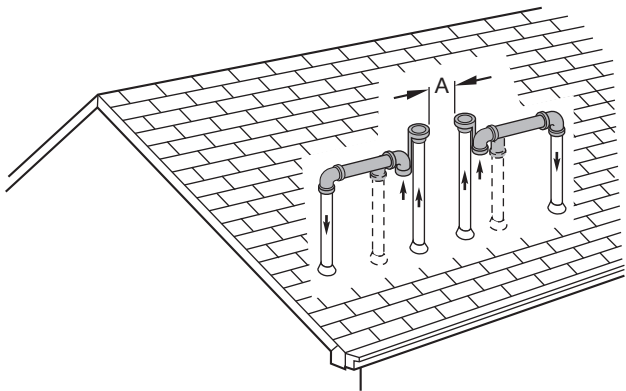

A96128

Fig. 34 - Rooftop Termination (Dimension “A” is Touching or 2 in. (51 mm) Maximum Separation)

PROCEDURE 4 — VENTING

Refer to Installation, Start-Up, and Operating Instructions supplied with each furnace for venting information. Each furnace must always be individually vented. Do not common-vent or breach-vent condensing furnaces. For direct-vent installations, refer to Fig. 34, 35, 36, 37, or 38 for proper termination. It is important that vent terminations be made as shown to avoid recirculation of flue gases.

PROCEDURE 5 — GAS SUPPLY PIPING

NOTE: All gas connections must be made through exposed outer side of each furnace. Do not common connect any connection other than supply and return-air ducts.

Furnaces are recommended to be provided with a single shutoff valve. However, individual shutoff valves may be required by local codes or jurisdictions. Refer to Installation, Start-Up, and Operating Instructions provided with each furnace for additional gas supply information.

PROCEDURE 6 — CONDENSATE DRAIN CONNECTIONS

The condensate trap is factory installed in blower shelf and factory connected for UPFLOW applications. Install condensate trap extension drain such that field drain connections are on the left side for LH (MAIN) furnace and on right side for RH (SECONDARY) furnace. (See Fig. 28.)

The condensate trap must be relocated for downflow and horizontal applications.

See furnace Installation, Start-Up, and Operating Instructions for details on attaching field drain for downflow and horizontal applications.

PROCEDURE 7 — ELECTRICAL SUPPLY CONNECTIONS

NOTE: All electrical power connections must be made through exposed outer side of each furnace. Do not common connect any connection other than supply- and return-air ducts.

1. Each furnace shall be connected to its own 115-vac power supply. The twinning kit installation interconnects the furnaces, allowing them to operate as a single furnace. The L1 (black) connection to each furnace must be connected to circuit breakers connected to the same service panel 115-vac phase leg.

On single-phase (residential) systems, each furnace circuit breaker should be located directly across from each other in

service panel, or each furnace circuit breaker should be located on the same side of service panel, but must skip 1 space to be connected to the same leg of the 1-phase power supply.

On 3-phase (commercial) systems, each furnace circuit breaker should be located directly across from each other in service panel, or each furnace circuit breaker should be located on the same side of service panel, but must skip 2 spaces to be connected to the same leg of the 3-phase power supply.

The proper 115-vac phasing of furnace connections permits 24-vac transformer phasing as described below.

2. Phasing of the connected 24-vac transformer secondary circuits can be determined with the LED status of both furnaces. See furnace Installation, Start-Up, and Operating Instructions and status code label on blower access panel or main furnace door. The furnaces’ transformers’ black leads should be connected to PR1 connectors and white leads to PR2 connectors on controls. If 1 or both LEDs are rapidly flashing, disconnect lead at TEST/TWIN terminal of LH furnace and observe LED at each furnace.
IF:
 - a. Both LEDs are on continuously:
System phasing is okay.
 - b. One or both LEDs are rapidly flashing:
 - (1.) Line voltage polarity is reversed.
 - (2.) Reverse SEC-1 and SEC-2 in furnace with rapid flashing LED.
 - c. One LED is off, 1 LED is on continuously:
 - (1.) The 24-vac circuit is inoperative on furnace with LED light off.
 - (2.) Check transformers, auxiliary limits, and door switches in both furnaces and correct problem.
3. Reconnect lead at TWIN/TEST terminal of LH furnace and observe LED at each furnace. The LEDs will glow steady for proper phasing.

PROCEDURE 8 — START-UP AND ADJUSTMENT

NOTE: Refer to Installation, Start-Up, and Operating Instructions supplied with furnace for detailed information.

1. Shut off all power and gas to both furnaces.

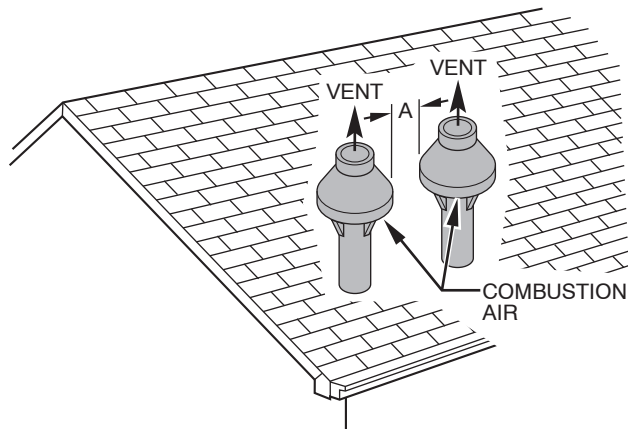

A93056

Fig. 35 - Concentric Vent and Combustion Air Roof Termination (Dimension “A” is Touching or 2 in. (51 mm) Maximum Separation)

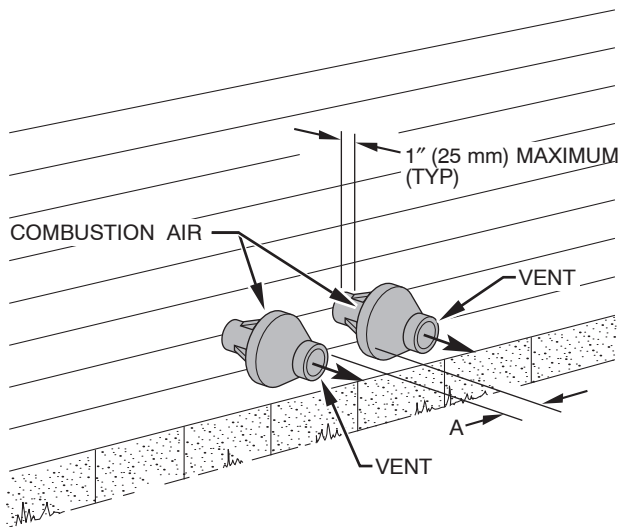

A93057

Fig. 36 - Concentric Vent and Combustion Air Side Termination (Dimension "A" is Touching or 2 in. (51 mm) Maximum Separation)

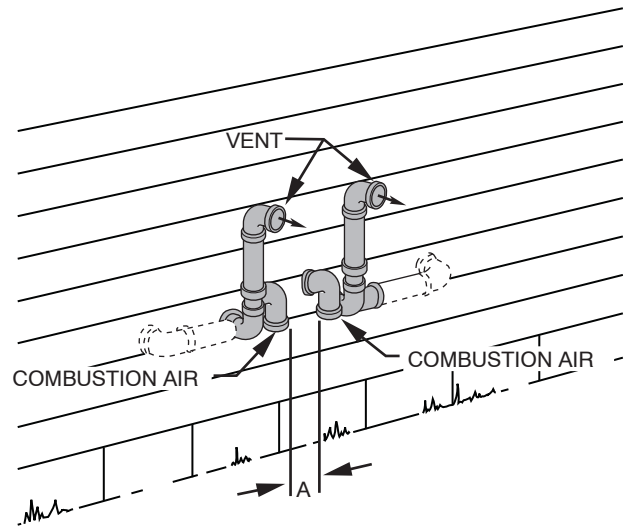

A96130

Fig. 38 - Sidewall Termination of More Than 12 in. (305 mm) (Dimension "A" is Touching or 2 in. (51 mm) Maximum Separation)

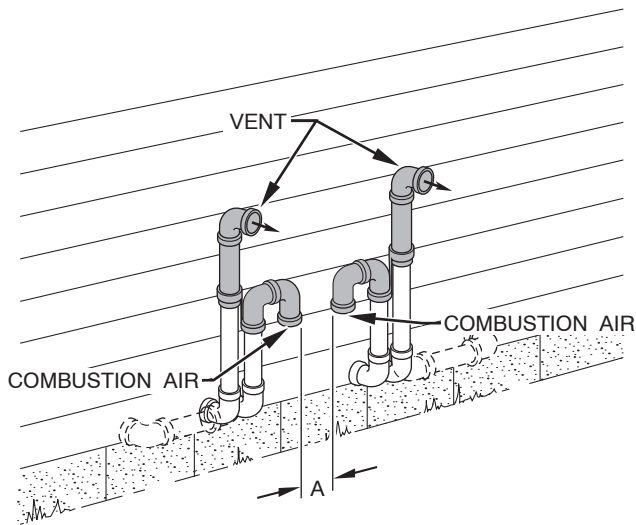

A96129

Fig. 37 - Sidewall Termination of 12 in. (305 mm) or Less (Dimension "A" is Touching or 2 in. (51 mm) Maximum Separation)

2. Position blower off delay switches on controls in BOTH furnaces to the SAME desired blower off delay in heating. See furnace Installation, Start-Up, and Operating Instruction for further details.
3. Attach twinning connection wiring label above the existing furnace wiring label on the inside of the L/H furnace blower access door. Use the following labels for the following applications:
 - Single-Stage furnaces with single-stage thermostat, 327893-101
 - Single Stage furnaces with two-stage thermostat, 327892-101
 - Two-Stage furnaces with single-stage or 2-stage thermostat, 327891-101
4. Attach twinning reference label 327956-101 on the outside of blower access door of RH furnace
5. Manually close the blower switch.

6. Turn on power and gas to furnaces.
7. Using appropriate section below, operate furnaces through 2 cycles in each mode to confirm correct operation by operating only the thermostat.
 - a. Single- or 2-stage gas heating thermostat R-to-W/W1 for low-gas heat. Single-stage thermostat with adaptive heating mode causes furnace to operate in low-gas-heat mode for up to 16 minutes, and then furnace automatically switches to high-gas heat. First stage of a 2-stage thermostat without adaptive heating mode causes furnace to operate in low-gas-heat mode indefinitely.
 - b. First and second-stage of 2-stage heating thermostat R-to-W/W1-and-W2 for high-gas-heat.
 - c. Thermostat R-to-G for continuous fan or 2-stage cooling low-cool blower.
 - d. Cooling thermostat R-to-G-and-Y/Y2 for single-speed cooling blower or for 2-stage cooling high-cool blower.
8. Reinstall control doors on both furnaces.
9. Instruct user in operation of furnaces and thermostat.

PROCEDURE 9 — SEQUENCE OF OPERATION

See Fig. 15, 16, or 17, and 39 or 40 for condensing furnace twinning connection and schematic wiring diagrams while reviewing sequence of operation.

Twinning operation is controlled by LH or MAIN furnace. The TEST/TWIN connection wire ensures the 2 furnaces coordinate their blower operation. When either furnace requires blower operation, both furnace blowers operate at same speed. Both furnaces operate simultaneously in the same mode: heat, cool, or continuous fan. Exceptions can occur if a safety switch on either furnace is opened by a problem (such as pressure switch, flame roll-out switch, main limit switch, twinning kit auxiliary limit switch, or flame-proving sensor). In such a case, the other furnace continues to operate unless open switch is the flame roll-out, main limit, or twinning kit auxiliary limit switch, in which case both furnaces respond.

Before performing component test, disconnect TKR yellow wire labeled TEST from LH furnace control center TEST/TWIN terminal. After removing yellow wire, component test can be initiated on each furnace individually as stated in Installation, Start-Up, and Operating Instructions.

A. Fixed Capacity Furnaces

SINGLE-STAGE HEAT, SINGLE STAGE FURNACES WITH SINGLE-STAGE GAS-HEAT THERMOSTAT

Operation in all modes (sequence of operation) is the same for twinned furnaces as for an individual furnace. See furnace Installation, Start-Up, and Operating Instructions for more information on the sequence of operation.

TWO-STAGE HEAT, SINGLE STAGE FURNACES WITH 2-STAGE GAS-HEAT THERMOSTAT

1. The two-stage thermostat determines if furnaces are operating in first-stage heat (LH furnace operates in heat while RH furnace blower operates but RH furnace is not heating) or if furnaces are operating in second-stage heat (both furnaces operate in heat), depending on how many thermostat stages are calling for heat. If two-stage cooling is used, Y1 from the thermostat will initiate both furnace blowers to the cooling speed and the first A/C unit. Y2 from the thermostat will go directly to the outdoor unit and initiate the second A/C unit.
2. Operation in all modes (sequence of operation) is the same for twinned furnaces as for an individual furnace. See furnace Installation, Start-Up, and Operating Instructions for more information on sequence of operation.

TWO-STAGE HEAT, TWO STAGE FURNACES WITH SINGLE-STAGE GAS-HEAT THERMOSTAT

NOTE: See Section 2, Procedure 2 - Electrical Connections, Step 3 for control board wiring and LHT switch setup.

1. LH furnace control determines whether furnaces are both operating in low-gas heat or high-gas heat, depending on the control's adaptive gas heating mode when the R-to-W/W1 circuit is closed in LH furnace.
2. Operation in all modes (sequence of operation) is the same for twinned furnaces as for an individual furnace. See furnace Installation, Start-Up, and Operating Instructions for more information on sequence of operation.

TWO-STAGE HEAT, TWO STAGE FURNACES WITH 2-STAGE GAS-HEAT THERMOSTAT

NOTE: See Section 2, Procedure 2 - Electrical Connections, Step 3 for control board wiring and LHT switch setup.

1. The 2-stage thermostat (NOT furnace control's adaptive gas heating mode) determines whether furnaces are both operating in low-gas heat or high-gas heat, depending on whether 1 or both thermostat stages (W/W1 or W/W1-and-W2) are calling for heat.
2. Operation in all modes (sequence of operation) is the same for twinned furnaces as for an individual furnace. See furnace Installation, Start-Up, and Operating Instructions for more information on sequence of operation.

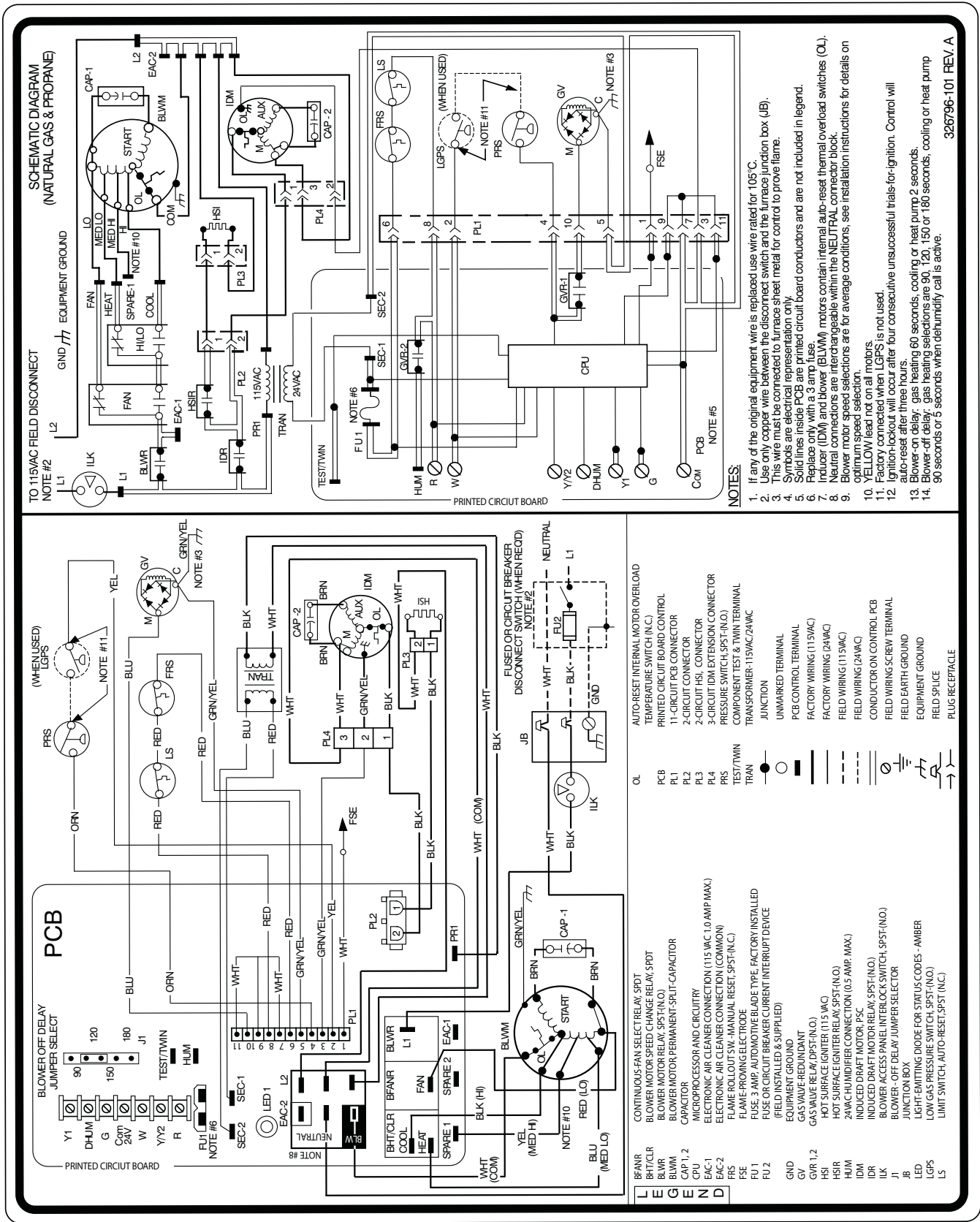
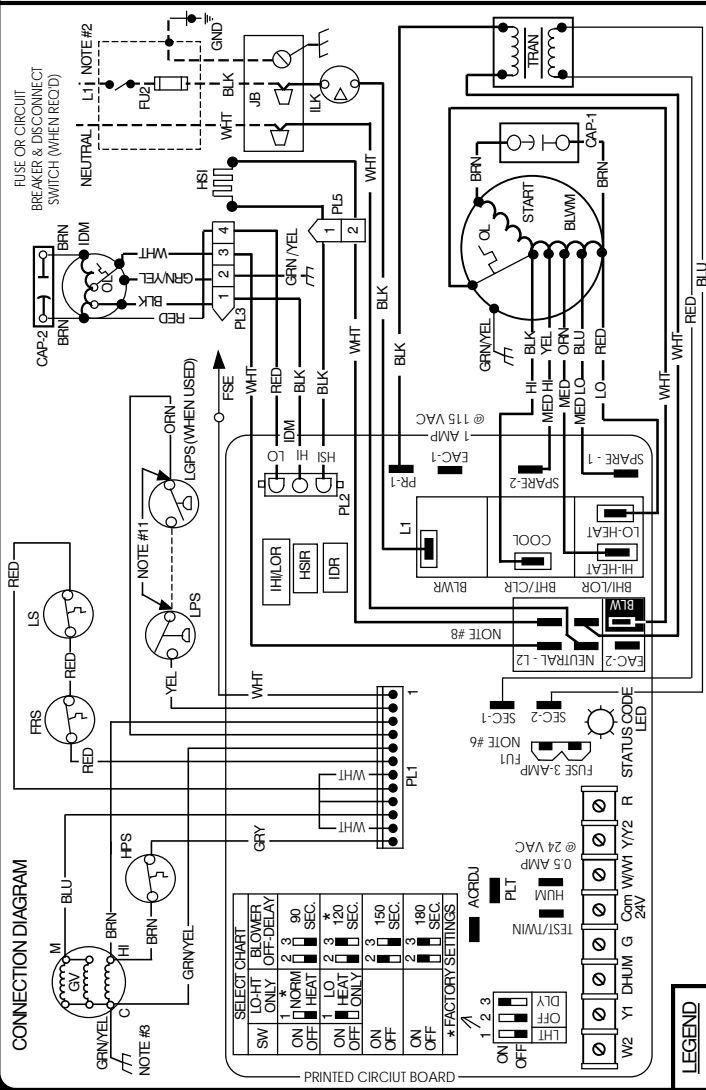
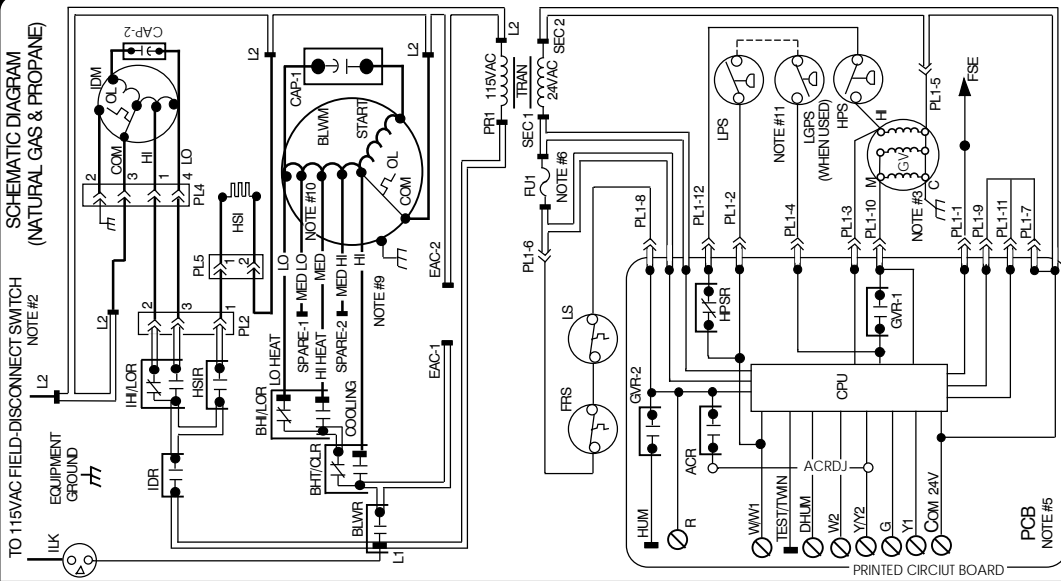

Fig. 39 - Fixed-Capacity Condensing Furnace Wiring Diagram

A02157



LEGEND

- ACR AIR CONDITIONING RELAY (SPST (N.O.))
- ACRDJ AIR CONDITIONING RELAY DISABLE JUMPER
- HI/LOR HIGH HEAT/LOW OIL RELAY
- BHT/CLR BLOWER MOTOR SPEED CHANGE RELAY (SPDT)
- BLWR BLOWER MOTOR RELAY (SPST (N.O.))
- BLWM BLOWER MOTOR RELAY (SPST (N.O.))
- CAP-1 CAPACITOR
- CPU MICROPROCESSOR AND CIRCUITRY
- DHJM DHJM CONNECTION
- EAC-1 ELECTRONIC AIR CLEANER CONNECTION (115 VAC, 1.0 AMP MAX.)
- EAC-2 ELECTRONIC AIR CLEANER CONNECTION (COMMON)
- FSE FLAME PROOFING ELECTRODE
- FUT FUSE, 3 AMP, AUTOMOTIVE BLADE TYPE, FACTORY INSTALLED (FIELD SUPPLIED AND INSTALLED)
- FUZ FUSE OR CIRCUIT BREAKER CURRENT INTERRUPT DEVICE (EQUIPMENT GROUND)
- GND EQUIPMENT GROUND
- GV GAS VALVE REDUNDANT
- GVR 1, 2 GAS VALVE RELAY, DPST (N.O.)
- HPS HIGH-HIGH PRESSURE SWITCH, SPST (N.O.)
- HPSR HIGH-HIGH PRESSURE SWITCH RELAY, SPST (N.C.)
- HSI HOT SURFACE IGNITER (115VAC)
- 24VAC HUMIDIFIER CONNECTION (0.5 AMP, MAX.)
- IDM INDUCED DRAFT MOTOR, 2-SPEED, SHADED POLE
- IDMR INDUCED DRAFT MOTOR RELAY, SPST (N.O.)
- IDMTR INDUCED DRAFT MOTOR RELAY, SPDT
- BLWR ACC ACCESS PANEL INTERLOCK SWITCH, SPST (N.O.)
- JUNCTION BOX
- LED LIGHT-EMITTING DIODE FOR STATUS CODES - AMBER
- LOW GAS PRESSURE SWITCH, SPST (N.O.)
- LOW-HIGH PRESSURE SWITCH, SPST (N.O.)
- LS LIMIT SWITCH, AUTO-RESET, SPST (N.C.)
- LSR AUTO-RESET INTERNAL MOTOR OVERLOAD TEMPERATURE SWITCH (N.C.)
- PCB PRINTED CIRCUIT BOARD CONTROL

PL1 12-CIRCUIT PCB CONNECTOR
PL2 3-CIRCUIT PCB HSI & IDM CONNECTOR
PL3 4-CIRCUIT CM MOTOR CONNECTOR (NOT SHOWN)
PL4 4-CIRCUIT IDM CONNECTOR
PL5 3-CIRCUIT FACTORY TEST CONNECTOR
PLT TRANSFORMER, 115VAC/24VAC COMPONENT TEST & TWINNING TERMINAL

PL1-1 JUNCTION TERMINAL
PL1-2 CONTROL PCB TERMINAL
PL1-3 FACTORY POWER WIRING (115VAC)
PL1-4 FACTORY CONTROL WIRING (24VAC)
PL1-5 FIELD CONTROL WIRING (115VAC)
PL1-6 FIELD CONTROL WIRING (24VAC)
PL1-7 CONDUCTOR ON CONTROL PCB
PL1-8 FIELD WIRING SCREW TERMINAL
PL1-9 FIELD EARTH GROUND
PL1-10 EQUIPMENT GROUND
PL1-11 FIELD SPICE
PL1-12 PLUG RECEPTACLE

NOTES:

1. If any of the original equipment wire is replaced use wire rated for 105°C.
2. Use only copper wire between the disconnect switch and the furnace junction box (JB).
3. This wire must be connected to furnace sheet metal for control to prove flame.
4. Symbols are electrical representation only.
5. Solid lines inside PCB are printed circuit board conductors and are not included in the legend.
6. Replace only with a 3 amp fuse.
7. Blower motor (BLWM) and inducer motor (IDM) contain internal auto-reset thermal overload switches (OL).
8. Blower motor speed selections are for average conditions, see installation instructions for optimum selection.
9. MED not available on some models.
10. Factory connected when LGPS is not used.
11. Ignition lockout will occur after four consecutive unsuccessful trials-for-ignition. Control will auto-reset after three hours.
12. Blower-on delay: gas high-heat 60 seconds; gas low-heat 45 seconds; cooling or heat pump 2 seconds.
13. Blower off-delay: gas heating selections are 90, 120, 150, 180 seconds, cooling or heat pump 50 seconds or 3 seconds when dehumidify call is active.

Fig. 40 - Two-Stage Condensing Furnace Wiring Diagram

Table 5 – Single-Stage Heating with Single-Stage Thermostat Using Two Single-Stage Furnaces

THERMOSTAT CONNECTIONS	CONTROL BOARD CONNECTION	ACTION
R	R	Power from control board to thermostat
W	W	Starts L/H and R/H furnaces for heating

Table 6 – Single-Stage Cooling with Single-Stage Thermostat Using Two Single-Stage A/C Units

THERMOSTAT CONNECTIONS	CONTROL BOARD CONNECTION	ACTION
R	R	Power from control board to thermostat
Y	Y/Y2 (Y on standard control board)	Energizes accessory cooling relay(s) to start L/H and R/H A/C for cooling
G	G	Starts both indoor fans on cooling speed (With Y/Y2 energized)
Dehum*	Dehum*	Reduces airflow in cooling mode from cooling speed to heating speed when Dehum input is removed

*Dehum is not available on all thermostats or control boards

Table 7 – Two-Stage Heating with Two-Stage Thermostat Using Two Single-Stage Furnaces

THERMOSTAT CONNECTIONS	CONTROL BOARD CONNECTION	ACTION
R	R	Power from control board to thermostat
W1	W	Starts L/H furnace for first stage heating
W2	None	Thermostat W2 wired directly to R/H accessory relay to start R/H Furnace for second stage heating

KGATW
Table 8 – Two-Stage Cooling with Two-Stage Thermostat Using Two Single-Stage A/C Units

THERMOSTAT CONNECTIONS	CONTROL BOARD CONNECTION	ACTION
R	R	Power from control board to thermostat
Y1	Y/Y2 (Y on standard control board)	Energizes accessory cooling relay to start L/H and A/C for first stage cooling and cooling speed blower
Y2	None	Thermostat Y2 wired directly to R/H accessory relay to start R/H A/C
G	G	Starts both indoor fans on cooling speed (With Y/Y2 energized)
Dehum*	Dehum*	Reduces airflow in cooling mode from cooling speed to heating speed when Dehum input is removed

*Dehum is not available on all thermostats or control boards

Table 9 – Continuous Fan Operation

THERMOSTAT CONNECTIONS	CONTROL BOARD CONNECTION	ACTION
R	R	Power from control board to thermostat
G	G	Starts both fans in heating speed*

*Staged continuous Fan operation is not available

Table 10 – Two-Stage Heating with Single-Stage Thermostat Using 2 Two-Stage Furnaces

THERMOSTAT CONNECTIONS	CONTROL BOARD CONNECTION	ACTION
R	R	Power from control board to thermostat
W	W/W1	Starts L/H and R/H furnaces in low heat or high heat, as determined by L/H furnace control board*

*LHT switches must be in correct configuration

Table 11 – Two-Stage Heating with Two-Stage Thermostat Using 2 Two-Stage Furnaces

THERMOSTAT CONNECTIONS	CONTROL BOARD CONNECTION	ACTION
R	R	Power from control board to thermostat
W1	W/W1	Starts both furnaces in low heat for first stage heating*
W2	W2	Starts both furnaces in high heat for second stage heating*

*LHT switches must be in correct configuration

Table 12 – Single-Stage Cooling with Single-Stage Thermostat Using 2 Single-Stage A/C Units

THERMOSTAT CONNECTIONS	CONTROL BOARD CONNECTION	ACTION
R	R	Power from control board to thermostat
Y	Y/Y2	Energizes accessory cooling relay to start both A/C units for cooling
G	G	Starts both indoor fans on cooling speed (With Y/Y2 energized)
Dehum*	Dehum**	Reduces airflow in cooling mode from cooling speed to heating speed when Dehum input is removed

*Do not remove ACRDJ from furnace control boards

** Dehum is not available on all thermostats or control boards

Table 13 – Two-Stage Cooling with Two-Stage Thermostat Using 2 Single-Stage A/C Units

THERMOSTAT CONNECTIONS	CONTROL BOARD CONNECTION	ACTION
R	R	Power from control board to thermostat
Y1	Y/Y2	Energizes accessory cooling relay to start L/H A/C for first stage cooling
Y2	None	Thermostat Y2 wired directly to R/H accessory relay to start R/H A/C
G	G	Starts both indoor fans on heating speed until Y/Y2 is energized
Dehum*	Dehum**	Reduces airflow in cooling mode from cooling speed to heating speed when Dehum input is removed

*Do not remove ACRDJ from furnace control boards

** Dehum is not available on all thermostats or control boards

Table 14 – Continuous Fan Operation

THERMOSTAT CONNECTIONS	CONTROL BOARD CONNECTION	ACTION
R	R	Power from control board to thermostat
G	G	Starts both fans in heating speed*

*Staged Continuous Fan operation is not available

KGATW