

HD10 High Definition UW Video Housing

- 6-10 Standard manual controls- Power on/off, Record-start/stop, Zoom-Wide/Telephoto, White Balance, Auto focus, Auto/Manual focus Switch, ND filter
- 250 ft depth rating
- Close to neutral buoyancy at approx. 33 ft
- BRS (Ballast Release System) for easy travel of if trouble occurs on a dive, simply pull the quick release pin on one of the wings, the wing and handle (ballast) release, the housing now becomes positive and shoots to the surface
- Includes 2.5" Color LCD monitor with battery and charger



- f/Panasonic AG-HMC150.....#EQHD10HMC150..... **3149.00**
 - f/Panasonic AG-HVX.....#EQHD10HVX200..... **2498.99**
 - f/Canon XL2.....#EQHD10XL2..... **2518.95**
 - f/Panasonic AG-HPX170.....#EQHDPHAGHPX1..... **2749.99**
 - f/Sony HVR-Z7U.....#EQHDSHVRZ7U..... **2999.95**
 - f/Sony PMW-EX1.....#EQHDSMPMEX1..... **2749.95**
- HDPro Underwater Housing**
- f/Sony PMW-EX3.....#EQHD14EX3..... **3899.00**

HD8 High Definition UW Video Housing

- Mechanical Controls
- Rugged PVC Material Construction
- Includes Color-Correcting Filter
- Includes Wide-Angle Lens
- Ballast Release System Handles
- Rated Down to 250'



- f/ JVC GY-HM100U.....#EQHD8HM100..... **1239.99**
- f/ Sony FX7.....#EQHSSHV1..... **1299.95**
- f/ Sony V1U.....#EQHSSHV1U..... **1299.95**
- FX7PRO** UW Video Housing.....#EQHD8FX7V1U..... **1999.00**
- HD8f** / JVC GY-HM100U.....#EQHD8XHM100..... **2294.95**

HD6 High Definition UW Video Housing

- Mechanical Controls
- Rugged PVC Material Construction
- Includes Color-Correcting Filter
- Includes Wide-Angle Lens
- Ballast Release System Handles
- Rated Down to 250'



- f/ Canon HF-M30/31/300.....#EQHD6CHF30..... **899.00**
- f/ Canon VIXIA HF S10 & HF.....#EQHD6CHFS101..... **749.95**
- f/ Canon HF-S21/20/200.....#EQHD6CHFS21..... **899.00**
- f/ Canon HG20 and HG21.....#EQHD6HG2021..... **799.99**
- f/ Canon HV40, HV30 and HV2.....#EQHD6HV40302..... **774.95**
- f/ Canon HF100, HF10 and HF.....#EQHDCHF100..... **799.99**
- f/ JVC GZ-HM400.....#EQHD6JGZHM40..... **899.00**
- f/ Panasonic TM10/SD10.....#EQHD6PTM10..... **899.00**
- f/ Panasonic TM20K/SD20K.....#EQHD6PTM20K..... **899.00**
- f/ Sony CX110/150.....#EQHD6SCX110..... **899.00**
- f/ Sony CX300/350.....#EQHD6SCX300..... **899.00**
- f/ Sony HDR-CX500 & HDR-CX5.....#EQHD6SCX500..... **798.99**
- f/ Sony CX550.....#EQHD6SCX550..... **899.00**
- f/ Panasonic HDC-TM300.....#EQHD6SDTM30..... **799.99**
- f/ Samsung HMX-H204.....#EQHD6SHMXH20..... **899.00**
- f/ Samsung HMX-S10BN.....#EQHD6SHMXS10..... **899.00**
- f/ Sony XR150.....#EQHD6SXR150..... **899.00**
- f/ Sony XR350.....#EQHD6SXR350..... **899.00**
- f/ Sony XR550.....#EQHD6SXR550..... **899.00**
- f/ Sony HDR-CX100.....#EQHD6SCX100..... **894.95**
- f/ Sony A1u.....#EQHD6SHA1U..... **889.99**
- f/ Sony HDR-HC9, HDR-HC7 &.....#EQHDSHHRHC9..... **899.00**
- f/ Sony HDR-HC9, HDR-HC7 &.....#EQHDSHHC579..... **799.99**
- f/ Sony HDR-XR100 & HDR-XR2.....#EQHDSXR10020..... **799.99**
- f/ Sony HDR-XR500 & HDR-XR5.....#EQHDSXR50052..... **669.95**

Pro8 Underwater Video Housing

- 7 Mechanical Controls
- Rugged PVC Material Construction
- Includes Color-Correcting Filter and Wide-Angle Lens
- Ballast Release System Handles
- Rated Down to 250'



- f/ Panasonic DVX100B.....#EQPP8DVX100Q..... **1249.95**
- for Sony PD170.....#EQPP8PD170..... **1299.00**
- f/ Canon GL2.....#EQPP8GL2Q..... **1249.95**
- f/ Sony VX-2100.....#EQP8VX2100..... **1299.95**

- Pro8X** Mechanical UW Housing.....#EQP8DVX100BX..... **1998.99**
- Pro-Pak 8** UW Video Housing.....#EQPP8DVX100B..... **1099.95**

Housing for Red 1 coming soon!..... **CALL**

For more Ewa-Equinox video housings see our website

Monitor backs available for all Housings

- Large 2.5" color active matrix LCD screen
- PAL or NTSC auto sense
- Rechargeable Ni-Cad battery that gives you one hour of view time
- The on/off switch is on the outside of the back, for easy access.

Call for additional details

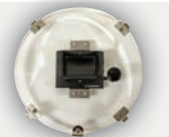

Large Aqualight Light System

- Depth-rated to 400'
- 3300°K
- Change lamps easily, no tools required
- Emits beautiful, soft, even, 180° light that has the appearance of ambient light



MALO2 Kit Includes:

Two 50-watt quartz-halogen light, 12 volt/12 amp rechargeable battery, charger & control arm.....#EQMALO2..... **1074.95**

ALQ2 Kit Includes:

Two 100-watt quartz-halogen lights, 12 volt/12 amp rechargeable lead-acid battery, charger & control Arm.....#EQALQ2..... **1694.95**

FILTERS

Size	27mm	37mm	43mm	46mm	49mm	52mm	58mm	67mm	72mm
Blue Water	#EQCF27BW 62.95	#EQCF37BW 54.95	#EQCF37BW 54.95	#EQCF46BW 59.95	#EQCF49BW 39.95	#EQCF52BW 59.95	#EQCF58BW 79.95	#EQCF67BW 94.95	#EQCF72BW 114.95
Green Water	#EQCF27GW 29.95	#EQCF27GW 54.95	#EQCF43GW 49.95	#EQCF46GW 59.95	#EQCF49GW 39.50	#EQCF52GW 59.95	#EQCF58GW 83.95	#EQCF67GW 94.95	#EQCF72GW 114.95

ewa-marine CAMCORDER HOUSINGS

Tested for use to a depth of 33'/10m. Light & still robust, effective against sand, rain, seawater, humidity, etc. Double-laminate PVC with optical glass ports.



Many New

Camcorders Supported:

- #EWWEX1 for Sony PMW-EX1..... **789.95**
- #EWWFX for Sony FX1, Z1..... **437.99**
- #EWW2000 for SONY VX-2000, PD-170..... **469.50**
- #EWWXA for CANON XL-1, H-1..... **536.50**
- #EWWHD for JVC HD-7..... **312.50**
- #EWWP2 for Panasonic HVX200..... **549.95**

For other Ewa-Marine video housings see our website

DiCAPac
www.dicapac.com

WP-D10 / WP-D20 Soft Housings

- PVC vinyl housing with a polycarbonate lens port
- UV coating on the lens port for clear pictures
- All controls are accessible
- Rated to a depth of 16.4' (5.0 m)
- Has pocket to accommodate fold-out LCD monitor
- Ideal for taking pictures in the rain, at the beach, or on the ski slopes
- Meets standard requirements for JIS (Japan Industrial Standards) IPX8 at 0.5 water pressure (underwater 5.0m), tested for 30 minutes
- Compatible with camcorders that have a length of 4.7" (112mm) or smaller, and a circumference no larger than 9" (228mm)



- WP-D10** For Small Camcorders.....#DIWPD10..... **41.00**
- WP-D20** For Small HD Camcorders.....#DIWPD20..... **59.95**

XDAmphibicam X3

Electronic & Mechanical Underwater Housing

- For Sony PMW-EX3 HD Camcorder
- Limited Production Semi-Custom Housing
- Window to View Camcorder's LCD Monitor • Includes Dome Port
- Color Bar Display • Tally light
- Visual Leak Alarm on Both Grips
- Rated Down to 330'



XDAmphibicam X3 Housing f/Sony PMW-EX3 #AMVHSPMWEX3 **11,900.00**

Phenom Z7LE

Electronic Underwater Camcorder Housings

Designed for the Sony HVR-Z7U camcorder

- Depth Rated to 330' (100m)
- Electronic and Mechanical Push Button Controls
- Marine Grade Aluminum
- 2 Coats of Polyurethane and Marine Grade Brass w/Stainless Steel Hardware



#AMVHSHVRZ7U Housing without w/o port..... **4,999.95**

Dive Buddy EVO HD Elite

Underwater Housing

The housing has a 3.5" color LCD back for easy enhanced viewing. It is depth-rated to 330' with a flashing moisture alarm. Features electronic controls, external hydrophone, and marine bayonet-mounted flat port.



f/Sony HDR-SR10/10D/11/12 #AMDBSHDRSR10 **1994.95**
 f/Sony HDR-HC5/ HDR-HC7/ HC9 #AMDBSHDRHC5 **1994.95**
 for Sony HDR-SR7/ SR8 #AMDBSHDRSR7 **2149.95**
 for Sony HDR-UX1/ SR1 #AMESHDRUX1 **2494.95**
 for Sony HDR-HC1/ HVR-A1U #AMDBSHVRA1U **1994.95**

VIDEO LIGHTS & MONITORS

Discovery 10W HID Light

- 10w clean, natural light.
- 15" Flexible Loc-Line Arm
- Two Sony NP-f500/NP-f570 batteries provides 2 hours burn time.



#AMVLDL0010 **974.95**



Monitors

Monitors supports resolutions up to 1080i, and is designed for under- or above-water use.

4.3" 16:9 TFT LCD Color Monitor #AMACHDM043 **1957.50**
 3.5" 4:3 TFT LCD Color Monitor #AMACFM0350 **504.95**

Dive Buddy EVO HD Elite Kits

Dive Buddy Evo Housing with Single Light

The housing has 3.5" color LCD back for easy enhanced viewing. It is depth rated to 330'. Incuded video light brings back natural colors underwater.

#AMDBSSR10 for Sony HDR-SR10, SR10D, SR11, SR12 **3769.95**
 #AMDBSHC5 for Sony HDR-HC9, HC7 & HC5 **3868.95**
 #AMDBSSR78 for Sony HDR-SR7 & SR8 **2494.95**
 #AMDBSUX1 for Sony HDR-UX1 & SR1 **3296.95**
 #AMDBSHC1 for Sony HDR-HC1 & HVR-A1U **3559.50**

SEA&SEA

Pro Electronic Underwater Housing

VX-S2 Housing

- A large folding mirror reflects the camcorder's LCD screen
- Designed for multiple camcorder models, requires a specific camera base
- Depth rating: 200'/60m
- Infrared control grip switches between video and still capture
- Includes 0.6x wide conversion lens • Leak detector alerts you to any accidental moisture in the housing • Underwater microphone captures sounds to accompany your video • Pressure-release valve ensures that excess air pressure is purged



VX-S2 for Sony HDR-UX1/HDR-SR1 #SEVXS2 **1674.95**
 Base for Mounting Sony HDR-UX5/UX7 #SEBSHDRUX5 **189.95**
 Base for Mounting Sony HDR-HC7 #SEBSHDRHC7 **174.95**
 Base for Mounting Sony DCR-DVD505 #SEBSDCRDVD50 **49.95**
 Base for Mounting Sony HDR-UX1/SR1 #SEBSHDRUX1 **169.95**

Snapper Dive HDDV Digital Camera & Housing

- Hi-Definition 1440 x 1080P resolution video at 30fps
- 5.0 MP digital stills
- 2.4" LCD monitor
- Built-in video light and flash
- 3x Optical zoom
- 4X digital zoom
- Use SD cards to 4 GB
- Digital stabilizer
- Snapper Skin: Protects camera if housing floods
- Depth-rated to 12' by itself • Housing depth-rated to 180'
- Polycarbonate • Easy-to-use buttons



Snapper 1080P HDDV Digital Media Camcorder with Hard-Shell Storm Case..... #BOC1080PC..... **299.95**
Snapper Dive 1080P HDDV Digital Media Camcorder..... #BOC1080PH..... **569.00**
Snapper Dive 1080P HDDV Digital Media Camcorder with Soft Travel Bag #BOC1080PHB..... **615.00**
Snapper Dive 1080P HDDV Camcorder Dual Lighting & Lens Kit #BO1080PD2LL..... **1714.00**

Bonica G8V15 LED Video Light

- Six 3W (15W total) LED bulbs provide 1500 lumens of light
- Eight 2400 mAh NiMH recharge. AA batteries powers the light for 60 minutes of full-power burn time
- Dimmer control allows to adjust light intensity from 0 to 100%



G8V15 LED Video Light (Head Only) #BOVLSH..... **379.95**
G8V15 LED Video Light Kit w/Tray & Handle#BOVLS... **448.95**

epic Video Housings

- Depth: 20'/tested @ 60'
- Optical quality, scratch-resistant lens • Adjustable pause/record mechanism • Incredibly strong polycarbonate hull



Elite: Fits most cameras within the dimensions: (HWD) 5 x 5 x 8.5" #EPE..... **274.95**
Sport: Fits most cameras within these dimensions: (HWD) 5 x 5 x 6.5" #EPS **259.95**
Pro HD: for the Sony HDR-FX1 #EPPHD..... **379.95**

ikelite

Camcorder Housings

- Molded of corrosion-free polycarbonate and operates safely to 200 feet
- Provides full view camcorder info, control functions
- Quad-seal camera controls
- Includes special viewfinder enhancement device • Weighted for near neutral buoyancy
- Dimensions: 4.75 x 6 x 11" • Weight: 9 lbs
- Many new camcorders supported



6039.21 Underwater Video Housing for Sony HDR-XR500 & HDR-XR520 #IK6039.21 **1234.95**
6071 for Canon Vixia HV20, HV30 & HV40.. #IK6071 **849.99**
6091 for Canon Vixia HF20, HF200 #IK6091 **759.95**
6095 for Canon VIXIA HF S10 & HF S100 #IK6095 **759.95**

UW Housings for Shoot & Share Video



5610.02 Video Housing for Pure Digital Flip Ultra & UltraHD (2nd Gen) #IK5610.02 **219.99**
5650.01 for JVC Piccio GC-FM1 #IK5650.01 **246.95**

5650.02 Compact Underwater Video Housing Including JVC Piccio GC-FM1 Camcorder #IK5650.02 **379.95**
5660.08 Housing for Kodak Zi8 #IK566008 **246.95**

For other Ikelite video housings see our website

ikelite Video Ports

Port for Raynox HD5050 attached to camcorder



#IK9304 Dome Port for Raynox HD 5050 **229.95**
 #IK9304.1 Flat Port for Raynox HD 5050 **149.95**

6320 Pro-V8 LED Video Light

- Three 5W LED Diodes Provide 510 Lumens
- Pop Bead Flex Arm 45 Degree Beam Angle • 4500 Kelvin Color Temperature
- Batteries Not Included • Rated up to 300'



6320 Pro-V8 LED Video Light... #IK6320 **236.95**

Pro Video Lite III Kits Lite Kits with Smart Charger



- Kits Include: ball joint mounting arm, battery pack, PRO/SPD smart charger, cable with in-line switch
- 100w** • Depth-rated to 300'/90m • Burn time: 25 minutes • 3400°K #IK6341.05 **579.95**

100w • Depth-rated to 300'/90m • Pop Bead Flex Arm • NiMH Battery/ Smart Charger • 3400°K #IK6341.06 **597.95**

6386.52 Pro Video Lite II (50W) #IK6386.52 **224.95**

Nocturnal Lights Single SLX 800xi LED Video Light Kit

- For Sea & Sea Housings
- With Hybrid Adapter, 12" Flex Arm
- SLX 800xi Light Head
- Three 3W (9W total) LED Bulbs • 800 Lumens • Powered by 12 AA Batteries • Adjustable Beam Angle • Rated up to 328' #NOSLX8XISS **569.95**



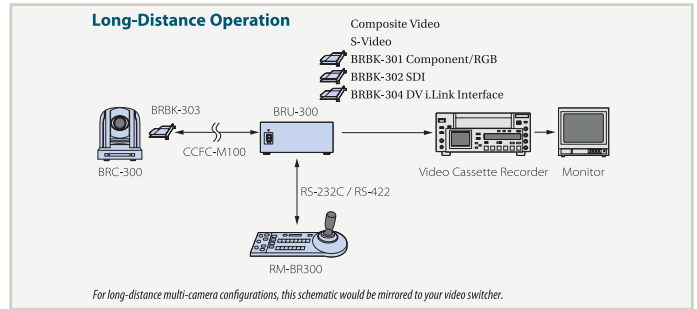
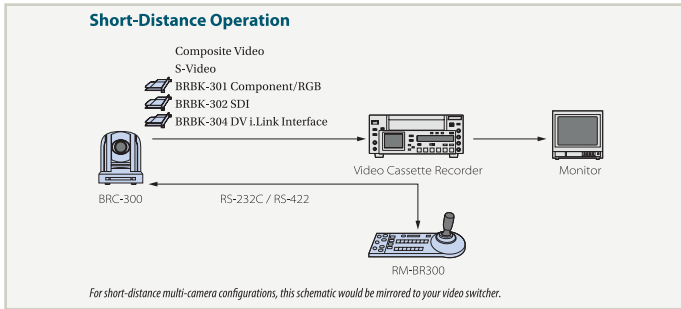

EVI-HD1
High-Definition PTZ Color Camera

Flexible full 1080i HD remote Pan/Tilt/Zoom camera enables you to output in one of 14 formats—eight HD and six SD video formats (including 1080/60i, 1080/30p, 720/60p, 720/25p, NTSC/PAL and HD-Analog and HD-Digital). It incorporates a 1/3" CMOS (2 MP) image sensor, 10x optical wide angle zoom lens, and HD-SDI output. The EVI-HD1's direct drive motor ensures quick but quiet movement, while the newly developed lens takes in a wide field of view.

#SOEVIHD1



SONY

BRC-Z330
High Definition PTZ Camera

Designed for a wide variety of remote video applications, the BRC-Z330 is a high definition PTZ camera featuring a 1/3" 2-MegaPixel CMOS image sensor and 18x optical zoom lens. The camera's wide pan/tilt ranges and smooth pan/tilt/zoom capability make it perfect for deployment in houses of worship and auditoriums, as well as educational facilities, conferences and concerts halls. The camera simultaneously delivers stunning high definition images in 1080i and 720p, while still having capability for output standard definition. Easy to install, it has a quiet operation that minimizes interference with ongoing events, helping it blend in naturally with the surrounding environment. #SOBRZ330.....**4200.00**



SONY

EVI-D70
1/4" PTZ Color Video Camera

Pan/Tilt/Zoom remote desktop or ceiling-mounted communication camera with a 1/4" EXview HAD image sensor, long 18x zoom lens, image inverting capability, high-speed operation, quiet direct drive operation, and six camera position presets. It includes a wireless remote control and can be controlled by optional RS-232C and RS-422 serial controllers.

#SOEVID70

- #SOCPIVD300 Telemetrics RS-232 Serial Desktop Remote Controller
- #SORMBR300 Sony RS-232C/RS-422 Serial Remote Control Panel
- #SOEVID8C1 8" Indoor Clear Dome Housing w/Pendant-Mount Bracket

SONY



BRC-300
3-CCD PTZ Color Camera

This broadband remote camera provide high-quality, low-noise SD images in 4:3 and 16:9. The 12x autofocus optical zoom has a high-accuracy, wide-range Pan/Tilt/Zoom capability. Controlled from a PC via RS-232C or RS-422 connection. Integrates into S-Video, RGB, iLINK, fiber or SDI systems.

- #SOBR300 Camera with three 1/4.7" advanced HAD CCD's
- #SORMBR300 Joystick Controller for up to 7 BRU/EVI Cameras
- #SOBRU300 Optical Multiplex Unit w/2 Card Slots
- #SOBRBK301 Analog Component or RGB Data (9-Pin) Card
- #SOBRBK302 Uncompressed SDI Video Card
- #SOBRBK303 Fiber-Optic Card
- #SOBRBK304 FireWire/iLink Board



SONY

EVI-D100
1/4" PTZ Color Video Camera

This Pan/Tilt/Zoom remote communication camera has a wide-angle lens and quiet, high-speed direct drive operation—ideal for smaller, closed-in venues. Along with its 1/4" CCD, 10x optical (4x digital) zoom, and six position presets, the camera features auto focus, auto white balance, and auto exposure. Includes wireless remote control, or can be controlled by optional VISCA/RS-232C serial controllers.

#SOEVID100

- #SORMBR300 Sony RS-232C/RS-422 Serial Remote Control Panel
- #SOCPIVD300 Telemetrics RS-232 Serial Desktop Remote Controller
- #SOCAMWMBKT CAM-WMBKT Wall Mount Bracket f/EVI-D100/D30 Cameras

SONY



BRC-H700 / BRC-Z700
HD 3-Chip PTZ Color Cameras

These compact HD cameras capture 1080i resolution in 60i/50i, offering wide pan and tilt ranges, Carl Zeiss lenses and fast, accurate movements. The highly sensitive BRC-H700, with 3 1/3" CCD sensors, has the widest viewing angle in the BRC series. The BRC-Z700 provides HD/SD output via 3 1/4" CMOS chips, a 20x optical zoom, and a very quiet and precise motor.

- #SOBRCH700 #SOBRZ700 #SOBRUH700 HD Optical Multiplex Unit
- #SOHFBKHD1 HD-SDI Card #SOBRBKH700 HD Optical Multiplex Card w/Audio for BRC-H700
- #SOHFBKSD1 Down-converts SD-SDI, Analog Component, RGB & Composite Card
- #SOHFBKXG1 WXGA, XGA and VGA Computer Inputs Card
- #SOHFBKTS1 FireWire/i-Link (for Use with HDV Systems) Card



SONY

TELEMETRICS CP-ITVD300
PTZ Remote RS-232 Controller

The Telemetrics CP-ITVD300 desktop remote controller has four direct RS-232 serial inputs for up to four EVI/BRC cameras. Joystick's proportional rate technology allows smooth, precise and simultaneous pan/tilt/zoom functions. Can also program predetermined angle, focal length and focus points. Compatible with Sony EVI-D30, EVI-D70, EVI-D100, BRC-300, BRCH-700 and Elmo PTC-100 cameras.

- #SOCPIVD300
- #SOCAITVDIN25
- #SOCAITVD50 50-ft., 9-pin D-Sub M/F Ext. Cable



SONY

RM-BR300
PTZ RS-232C/RS-422 Remote Control Unit

The Sony RM-BR300 joystick remote controller has one input for each RS-232C and RS-422 serial port, and can control up to 7 EVI/BRC Series cameras that are daisy-chained from one source camera in your system.

- #SORMBR300
- #SORC815 Sony 15m Daisy Chain RS-232C Control 8-pin Mini-Din Cable
- #SOCAITVDIN6 6-ft., 8-pin Mini-Din to 9-pin D-Sub RS-232C Control Cable
- #SORC8931 15-ft., 8-pin Mini-Din to 9-pin D-Sub RS-232C Control Cable
- #SOCAITVDIN25 25-ft., 8-pin Mini-Din to 9-pin D-Sub RS-232C Control Cable



SONY

PRO POV CAMS

Remote Head and Micro Camera Systems

Designed for industrial video, diagnostics, scientific imaging, and specialty programming such as reality TV, these tiny, high-resolution cameras can be mounted in places inaccessible to standard cameras—providing unique points of view for a range of uses. Whether focusing on an auto plant or a petri dish, an operating table or a poker table, these fixed focus professional systems will capture details otherwise impossible to record. Each camera head is connected by cable to a dedicated camera control unit (CCU), purchased separately, and requires a C-mount, bayonet or micro mount lens.



SONY HXR-MC1 Compact HD POV Camera and Recording System

A stunning full high-definition compact point-of-view (POV) camera, the HXR-MC1 consists of a small camera unit and a handheld controlling unit with LCD panel and recording function. This all-in-one tiny camera system needs no extra equipment, take it out and just start shooting. The camera unit is also splash-proof. Moreover, the unique style of the HXR-MC1 enables shooting in unordinary conditions and angles, such as shooting sports scenes from the user's point of view and onboard shooting in motor sports. Thanks to the LCD-equipped main unit, once the shot is taken, users can check the material immediately.

- Achieves its balance of compact size, light weight and superb image quality through the use of solid-state recording onto Memory Stick PRO™ Duo media using AVCHD compression. The HXR-MC1 can record up to six hours of high-definition content onto a 16GB Memory Stick media.
- Offers HD 1920 x 1080 resolution, and features Sony's ClearVid CMOS Sensor system enhanced by Exmor technology for high-quality digital signals with extremely low noise.
- Even with a 10x optical zoom and a built-in mic, the camera measures only 1-1/2 x 1-11/16 x 3-1/2" allowing it to be attached to various devices such as helmets or cars. Screw holes on the bottom of the unit make mounting easier. It is also splash-resistant for use in the rain.
- Recording and playback are performed within the HXR-MC1's control unit, eliminating the need for external recording devices or facilities. The combination of Exmor and CMOS sensor technologies result in low power consumption and maximum battery operation of up to 405 minutes.

- Control unit has a 2.7" 16:9 touch-screen LCD panel. Set-up during shooting or video operation can be carried out simply by touching the LCD panel.
- The control unit is also equipped with a recording button, zoom lever, and manual control dial, so users can control the camera remotely while watching the images. External monitors are not needed.
- HD video is recorded in AVCHD, which uses MPEG-4 AVC/H.264 compression, the same method used in Blu-ray Disc technology. **#SOHXRMCIACC** **2349.95**

MN-43H

1/2" CCD Color Lipstick Camera

This high-performance micro camera is ideal for medical and scientific applications as well as covert surveillance. Designed mainly for indoor use, the MN-43H offers low-light sensitivity down to 5 lux, and 470 lines of horizontal resolution.

- 1/2" CCD delivers 768 x 494 effective pixels
- Accepts 14 different lenses
- Manual white balance and shutter

- #ELMN43H** **#ELCC431E** Camera Control Unit for Elmo Remote-Head Cameras
- #ELTT3318** 18mm, f3.3 Micro Mount Lens for 1/3-Inch CCD
- #ELTT203** 1/3-Inch 3.0 mm, f/2.0 Lens
- #ELTT1655** 1/3-Inch 5.5mm, f/1.6 Micro Camera Lens
- #ELEMCO2H** 2 Meter/6.6 foot Camera Cable **#ELEMCO3H** 3 Meter/10 Foot Camera Cable
- #ELEMCI2H** 12 Meter/39.4 Foot Camera Cable **#ELACE12A** 120 Volt AC Power Supply

ELMO



IK-M44H

1/2" CCD Micro Camera Head

Offering 470 lines of resolution and an ultra-fast shutter, the IK-M44H is a micro remote-head camera that produces finely detailed video for a variety of industrial applications.

- 1/2" CCD (410K pixels)
- Minimum 5 lux
- Accepts 12mm micro-mount lenses (3mm–24mm)

- #TOIKM44H**
- #TOIKCU44A** Camera Control Unit for Toshiba IK-M44 Camera Head
- #TOJKL15M2** 15mm f/2.0 Micro Mount Lens
- #TOJKL04M2** 4mm f/2.0 Micro Mount Lens for Toshiba
- #TOJKL24M2** 24mm f/3.1 Micro Mount Lens

TOSHIBA



Panasonic

AG-HMR10 • AG-HCK10

Full HD Portable SD Memory Card Recorder and Multi-Purpose Camera Head

Ideal for applications in video production, sports coaching, health-care, law enforcement, remote operation/ surveillance, and much more, the AG-HMR10 is a handheld, battery-operated portable recorder with HD-SDI input and output, while the AG-HCK10 camera head features three 1/4" native HD resolution 3-MOS imagers, 12x optical zoom, and Optical Images Stabilizer (OIS).



When connected via included 3m detachable cable (optional 10m cable is also available), iris, focus and zoom can be remotely controlled from the recorder. The HMR10 records in HD formats including 1080/60i, 1080/50i, 720/60p and 720/50p.

- Equipped with an HD-SDI input and output, the HMR10 recorder is also suitable for back-up recording from any HD-SDI-enabled camera or for use in studio or event production.
- In addition to HD-SDI in/out the recorder features HDMI out and USB 2.0, internal speaker and headphone mini jack, and 3.5-inch color LCD monitor that displays content in thumbnail images for quick viewing.
- For editing or playback, users can instantly transfer content from the SD memory card to Mac or PC computers with an SD/SDHC card reader or by connecting the HMR10 recorder directly via its USB 2.0 interface.
- To simplify shot selection, you can add a mark to the thumbnail images of each clip. You can then display and play only the clips that have shot marks.
- Pre-REC function ensures you always get the shot you want by letting you continuously store, and subsequently record, images and sounds for 3 seconds before the REC button is pressed.
- Plays back the last 2 seconds of the most recently recorded clip for quick confirmation.
- The date, camera operator, location, title and other information can be added to the image data.

AG-HMR10 (B&H# PAAGHMR10).....**CALL** **AG-HCK10 (B&H# PAAGHCK10)**.....**CALL**



XH-A1s • XH-G1s

Professional HDV Camcorders

The XH-A1s and XH-G1s encapsulate a wealth of features in a compact, 3-CCD camcorder that captures 1080i HD video at frame rates of 60i, 30p and 24p. Genuine Canon L-series 20x wide-angle (32.5-650mm equivalent) HD zoom ensures outstanding resolution and color reproduction.

Behind the lens are three 1/3" 16:9 1440 x 1080 CCDs delivering superior picture quality and wide dynamic range with virtually no color noise. Other features include an analog-digital converter, built-in XLR inputs with external leveling, a 2.8" widescreen LCD (207K pixels), and two built-in ND filters. Otherwise the same, the XH-G1s steps up with the Professional Jack Pack which offers HD-SDI and SD-SDI output, Genlock input and SMPTE timecode input/output, for multi-camera shoots.



- Whether shooting handheld, from a moving car, or on a swaying bridge, Canon's super-range OIS combines gyro- and image sensors to keep your picture steady.
- DIGIC DV II technology processes the HDV signal with 4:2:2 color sampling, ensuring optimal color reproduction in skin tones and in high-contrast scenes. For more precise image control there are 7 Program AE modes and nine custom presets, to adjust hue, gain, sharpness, setup level, and Cine gamma settings. Then save the settings on an SD memory card for future use.
- Instant AF uses two sensors to provide fast and accurate focus, even in low light.
- Audio capabilities include two-channel audio performance; two built-in XLR terminals with separate audio-input sensitivity settings; the ability to simultaneously record sound from the supplied internal microphone and an external microphone; line output level switching; an audio (manual) limiter and a new metal headphone jack for reliable connectivity. The result is better overall flexibility and control of the camera by enabling the use of one cameraman to do the job of many.

CAXHA1S **Call or Log-on**
Canon 72mm 0.8x Wide Angle Lens (B&H# CAWDH72) 339.95

XL-H1A • XL-H1s

The Canon XL-H1a is designed to meet the needs of broadcast ENG producers, documentary, film, and commercial videographers. Genuine 20x HD optics and exceptional image processing result in brilliant HD image capture. Achieve 1080i HD resolution at 25 Mbps with selectable frame rates of 60i, 30p, and 24p. Fully customizable system has a 1/3" XL mount w/three native 16:9 image sensors (1440 x 1080), Cine control, multiple output options, and a well-balanced design—an ideal tool for meeting the demands of advanced video work. Otherwise the same, the XL-H1s steps up with the Professional Jack Pack which offers HD-SDI and SD-SDI output, Genlock input and SMPTE timecode input/output, for multi-camera shoots.



- The standard lens offers unprecedented control over zoom, focus and iris settings, delivering an even higher level of creative expression. Canon 20x Zoom (38.9-778mm equivalent) Professional L Series Fluorite features an SR multi-coating which minimizes ghosting and veiling of the image, and ensures the highest level of resolution and color fidelity.
- One of the most useful and desirable features that distinguishes the XL line is the interchangeable lens system. This flexibility of optics opens the door to total creative freedom, which is further enhanced by adaptors that are available for the camera's XL mount.
- Complete customization brings a high level of tuning to achieve creative objectives with precision.
- 2.4" widescreen combination EVF/LCD Monitor (215,000 pixels) with adjustable brightness, contrast, color and sharpness as well as Black & White mode. Offers comfortable shooting for any operator.
- Total Cine control • Optical image stabilization • SD slot to save camera settings
- Combination flip-up 16:9 EVF & LCD panel • Aspect guides in viewfinder
- SMPTE time code and color bars with 1kHz reference tone
- Dual XLR (line/mic level) inputs with +48v Phantom power (4-channel option with MA-300)
- Clear Scan • 2 built-in ND filters • LANC terminal

XL-H1A (CAXLH1A) **Call or Log-on**
 XL-H1s (CAXLH1S) **Call or Log-on**
6x XL Wide Angle Zoom HD Lens (CAG6LH1) 2499.95

XF100 • XF105

HD 1920 x 1080 4:2:2 CCD Camcorders

The XF100 and XF105 feature 50Mbps MPEG-2 4:2:2 recording of 1920 x 1080 HD video onto Compact Flash (CF) cards for unsurpassed image quality and efficient workflow at an affordable price. Ideal for documentary and independent filmmaking and event videography, they utilize file-based MPEG-2 compression with an MXF File Wrapper to ensure full compatibility with existing industry infrastructure, metadata and non-linear editing systems. They are equipped with Canon 10x (30.4- 304mm equivalent) HD lens; enable the easy set-up and capture of high-definition 3-D video when two XF100 or XF105's are paired; and have built-in infrared low-light enabling the capture of HD video in complete darkness. Otherwise the same, XF105 adds HD-SDI output, genlock, and SMPTE time code (I/O) terminals for multi-camera or 3-D productions.



XF100 (CAXF100) or XF105 (CAXF105) Call or Log-on

XF100 • XF105 • XF300 • XF305 All Feature

- Single or three 1920 x 1080 CMOS image sensor delivers outstanding Full HD video recording with minimal noise. 50Mbps constant bit rate provides the bandwidth needed to capture their superior resolution and color in spectacular detail.
- 4:2:2 color sampling provides ultra-fine transitions in tone and color and maintains the highest quality image for use in post production processes such as chroma keying, color grading, advanced compositing and effects.
- In addition to rugged, solid-state construction and the speed and ease of file transfer to computers, CF cards are cost effective and widely available. They feature hot-swappable dual card slots and support UDMA CF cards for maximum performance.
- The Canon XF Codec is supported by Adobe, Apple, Avid, and Grass Valley, to ensure compatibility with widely used software programs.
- Canon's proprietary DIGIC DV III Image Processor, ensures natural, lifelike colors and captures tonal gradations and shadow detail with remarkable accuracy. DIGIC DV III also powers Canon's innovative Face Detection Technology, an autofocus option that can significantly reduce the effort required when camera operators work alone, such as in news applications.
- To maximize their adaptability across various production environments, they are equipped with the ability to record at multiple bit rates, resolutions and variable frame rates for slow and fast motion.
- Additional professional features include variable-interval (for time-lapse) and frame-record for stop-motion animation, and a photo feature for frame-grabs.
- XF100 and XF105 features a 3.5-inch (920,000 dot) LCD monitor, while the XF300 and XF305 features a rotating 4-inch, 1.23-megapixel LCD monitor that can be positioned at either the right or left side of the camcorder, allowing for easy viewing even in the most difficult shooting positions.
- The LCD monitor also provides a display of the built-in waveform monitor and (XF300, XF305 add a vectorscope) to aid in achieving accurate exposure and color levels while shooting. Additionally, the LCD can show peaking, edge-monitor-focus and magnify the image, enabling users to confirm critical focus, an essential objective in all HD production. They also come equipped with 0.24", 260,000-dot (XF100/300) and 0.52" 1.55-megapixel color electronic viewfinder (XF300/305), providing ample resolution for critical focus and 100% field-of-view coverage for accurate judgment of composition.
- For audio, they feature a built-in stereo mic as well as dual XLR inputs for external audio sources. They support 16-bit PCM audio at 48 kHz with automatic and manual audio level adjustment.

XF300 • XF305

HD 1920 x 1080 4:2:2 3-CCD Camcorders

The XF300 and XF305 step up with three 1920 x 1080 CMOS sensors which deliver outstanding Full HD video recording with minimal noise. They also feature Genuine Canon 18x HD L-series lens which has a focal length of 29.3-527.4mm (35mm equivalent) and a Full Manual Focus mode with mechanical "hard" end stops and distance markers for professional operability and repeatable manual focus. HI-UD (high-index, ultra low dispersion), UD and aspherical lens elements minimize chromatic aberrations and provide a compact size and weight to the lens – while also delivering a resolution of 1000 TV lines. The lens also features a SuperRange Optical Image Stabilizer (OIS) system featuring Dynamic and Powered modes for optimal performance in the greatest variety of situations. Otherwise the same, XF305 adds HD-SDI output, genlock, and SMPTE time code (I/O) terminals for multi-camera or 3-D productions.



XF300 (CAXF300) or XF305 (CAXF305) Call or Log-on

Canon XL-2

Professional MiniDV Camcorder



The only prosumer camcorder to offer an interchangeable lens system, the LX-2 also offers a host of professional functions including 16:9 aspect ratio, scan-matching, time code and custom picture looks. It also has 30-frame and 24-frame interlaced and progressive modes.

- 3 1/3" CCD's (680k pixels) with horizontal pixel shift
- Separate progressive scan CCD for each primary color
- Interchangeable XL lens system
- Complete image control including custom presets
- 2-bit DSP (Digital Signal Processor) allows customizable Cine look
- 20x Fluorite zoom lens (5.4 - 108mm) with OIS
- 16:9 and 4:3 aspect ratio shooting formats
- 4-channel audio, two XLR audio inputs with phantom power (+48v)
- SMPTE time code
- Variable frame rates—60i / 30p / 24p (2:3 and 2:3:3:2)

XL-2 Professional MiniDV Camcorder (CAXL2)
Ultimate DVD Guide to the XL-2 (FUDVDXL2).....**39.95**

Canon

GL-2 3-CCD MiniDV Camcorder



Building on their expertise in 35mm photographic and broadcast TV lenses, the GL-2 is equipped with Canon's exclusive L-Series Fluorite optical technology for outstanding imaging power and shooting versatility in a lightweight, portable design. To complement the lens, Canon's superb optical stabilization system eliminates image shake due to a wide range of movement and/or high wind conditions.

- 20x Fluorite lens
- Three 1/4" CCD's, 410K pixels each
- Optical image stabilization
- 30P frame movie mode
- 2.5" LCD with 200K Pixels
- Balanced XLR audio inputs with manual levels
- Manual Aperture/Shutter/Gain
- 16:9 Aspect Guides, Custom Keys, Variable Zoom Speeds, SMPTE Bars, Control-L, Clear Scan

GL-2 3-CCD MiniDV Camcorder (CAGL2)
Ultimate DVD Guide to the GL-2 (FUDVDGL2).....**29.95**
0.7 Wide Angle Lens with Hood (CAWD58H).....**163.95**
MA-300 Dual-XLR Audio Adapter (CAMA300).....**164.99**

for XL-H1A, XL-H1s

FU-2000 Color Viewfinder: A 2.4" remote color viewfinder that connects to your camcorders color viewfinder socket or to the optional ZR-2000 Zoom Remote Controller. Useful for times when the shoulder-mount viewfinder is inconvenient. Includes a built-in shade for brightly lit environments. (B&H# CAFU2000).....**369.00**

for XL-H1A, XL-H1s, XL-2

FU-1000 Monochrome Viewfinder: A 1.5" professional-quality B&W CRT viewfinder. With a horizontal resolution of 500 lines, it makes critical focusing easier in tough shooting situations. (B&H# CAFU1000).....**139.95**

For XH-A1s, XH-G1s

WD-H72 72mm 0.8x Wide Angle Converter Lens: Provides an 0.8x wider angle of coverage for the times when you are shooting in a confined space or for scenery. (B&H# CAWDH72).....**339.95**

HC-4200 System Case: A solid and lockable reinforced case for transportation and storage protection. (B&H# CAHC4200)....**329.95**

For XL-2, GL-2, XH-A1s, XH-G1s, XL-H1A, XL-H1s

SBR-1000 Shooting Brace: Offers additional support of your video camera. The neck strap is designed to increase comfort during long shoots. (B&H# CASBR1000).....**184.95**

ZR-1000 Zoom Remote Control: Plugs into the GL-2 and XL-2 via their Control L (LANC) terminal, giving you wired remote control of such functions as record start/stop, zoom and focus. Ideal for using while the camcorders are mounted on a tripod. (B&H# CAZR1000).....**175.99**

ZR-2000 Remote Zoom Controller: Connects to the LANC terminal of your camcorder, and controls recording start/stop, focusing, and 16 different zoom speeds. Especially useful when your camera is mounted on a tripod and maximum stability is desired. (B&H# CAZR2000).....**369.95**

VL-10Li II Battery Video Light: A 10w light that improves lighting and image quality whether you are shooting indoors or out. Powered by a 900 Series battery (B&H# CAVL10LI2).....**79.95**



For XL-2, GL-2, XL-H1A, XL-H1s

DM-50 Directional Stereo Microphone: Attaches to the hot shoe for cable-free operation. Powered by the camcorder's power source. Windshields included. (B&H# CADM50).....**144.95**

MA-300 Dual XLR Microphone Adapter: Provides 2 additional XLR terminals, allowing you to connect and use unbalanced microphones on all four channels. (B&H# CAMA300).....**164.99**

HC-3200 System Case: A solid, lockable case for transportation and storage protection. (B&H# CAHC3200).....**429.95**

for XH-A1s, XH-G1s, XL-H1A, XL-H1s, XL-2

FS-72U 72mm Filter Set: A set of three 72mm filters (UV, Neutral Density and Circular Polarizer) to enable creative control of challenging lighting conditions. (B&H# CAFS72U).....**112.95**

TA-100 Tripod Adapter: Allows you to quickly mount and dismount your camcorder on or off a tripod. (B&H# CATA100).....**145.95**

Interchangeable Lenses for XL-H1A, XL-H1s, XL-2

The XL-H1A, XL-H1s and XL-2 accept a host of interchangeable XL lenses or Canon's extensive range of photographic lenses. For wide-angle imaging, Canon offers a 3x Wide-Angle Lens with a resolution in excess of 600 TV lines, while the 16x Mechanical Servo Zoom Lens gives you the flexibility of calibrated focus and zooms. For added optical lens magnification, apply the 1.6x Extender between the camcorder and the zoom lens. There is also a 16x Automatic Lens with Super Range Optical Image Stabilization. Using the optional EF Adapter opens you to a wealth of Canon EOS EF photographic lenses, a tremendous super telephoto boon to those producing wildlife, astronomy or surveillance videos.



3x Wide-Angle Zoom Lens: The 3x (3.4-10.2mm f/1.8-2.2) short zoom gives your camcorder a 70° field of view, making it ideal for shooting interiors as well as landscapes. It incorporates 18 high-quality precision-crafted optical elements to deliver extraordinarily sharp images. Six-blade iris for minimal light flare. Manual zoom and focus ring. Built-in 1.5x ND filter. (24mm—72mm in 35mm). (B&H# CA3XXL1).....**1,199.95**

16x Manual Zoom Lens: The 16x (5.4-86.4mm f/1.6) manual servo zoom lens gives you the flexibility of calibrated power zoom, power iris (has auto iris capability), two built-in ND filters and calibrated manual focus. Has a macro and flangeback adjustment mechanism. Includes soft case. (B&H# CAM16XXL1S).....**1,499.95**

RC-72 Aspect Ratio Converter: When shooting in 4:3 mode, this 0.8x converter provides the same angle of view as 16:9 mode. (B&H# CARCXL2).....**279.95**

EF Adapter: Allows the attachment of over 50 high-quality Canon photographic EF lenses—ranging from Fisheye to Super Telephoto to a choice of versatile zoom models. (B&H# CAEFAXL1).....**449.95**

1.6x Extender: Fits between body and lens to increase the focal length of Canon XL lenses by 1.6x. (B&H# CA1.6XXL1).....**399.95**

Reconnaissance, Intelligence and Target Acquisition

These versatile night vision solutions are specifically designed to capture high-resolution imagery directly to various standard and high-definition video camcorders. Using a modular system to facilitate high-performance video capture, these scopes exhibit extraordinary sensitivity in critical low-light operation, and will transform any dark scene into bright, high-resolution video. Both the AstroScope and Prowler systems can not only attach directly to fixed- and interchangeable-lens camcorders, their front-end C-mounts allow use of any number of professional-grade 35mm cameras and lenses.

AstroScope™ 9350XL-3PRO

This advanced night vision module is designed for Canon's XL series standard and HD camcorders. Utilizing Canon's 20x zoom lens enables long-range surveillance and evidence capture, at the same time permitting you to take advantage of the vast array of Canon-quality EOS EF still imaging lenses (with the addition of Canon's EF Lens Adapter—B&H #CAEFAXL1).

- Intensifier (CIU) module powered by the camcorder
- Maintains all camera functions including image stabilization
- No backfocus adjustments needed



9350XL-3PRO System Includes:

- Gen III Common Module Central Intensifier Unit
- Back Body Adapter (BBA)
- Front Lens Adapter
- Simple "Start Here Card"
- Soft-Sided Drawstring Lens Bag
- Lens Cleaning Cloth

#ASNVCXL (914657).....**5,849.95**

AstroScope™ 9350BRAC Systems

The AstroScope 9350BRAC systems are designed for video camcorders with a fixed (non-removable) lens. They require an optional standard C-mount objective lens, per your intended requirements for high performance.



9350BRAC systems include:

- Gen III central intensifier unit module (powered by AAA Batteries)
- Custom-designed relay lens
- Camera platform bracket with standard 1/4" x 20" tripod mount
- Eyepiece adapter (EPA) with cold shoe accessory adapter
- C-mount front lens adapter (FLA-C)
- Simple "Start Here" card
- Standard AAA batteries
- Lens-cleaning cloth

#ASNVBCGL2	Pro 3rd Generation Night Vision Adapter Kit for the Canon GL2	5,399.95
#ASNVBSPD170	9350BRAC DSR PD170 Night Vision Bracket	5,399.95
#ASNVBPAGHVX2	9350BRAC-HVX-3PRO Night Vision Bracket	5,800.00
#ASNVBSHDRSR1	9350BRAC-SR1-3PRO Night Vision Bracket	5,800.95
#ASNVBPAGDVX1	9350BRAC-DVX100 Night Vision Bracket	5,800.00
#ASNVBHVRA1U	9350BRAC-A1-3PRO Night Vision Bracket	5,800.00
#ASNVBCXHG1	9350BRAC-XHG1-3PRO Night Vision Bracket	5,800.00
#ASNVBHVZR21U	Night Vision Adapter Kit for Sony HVR-Z1U/ HDR-FX1	5,399.95

AstroScope™ 9323B ENG

9323B-3N for ENG/EFP 2/3" B-4 (Sony-Type) Bayonet Mount

Systems Includes:

- Gen III thin film image intensifiers
- Supports 2/3" cameras with B-4 (Sony-type) bayonet mount
- Intensifier module powered directly from host camera
- Permits the use of all standard optics
- Soft-sided drawstring lens bag
- Lens-cleaning cloth
- Support for high-definition (HD) models



ASNVABENG (914415).....**8,798.95**

Prowler Pocket Scope

This Gen III pocket surveillance scope incorporates an internal flood light illuminator that allows night viewing up to 200 feet. An optional laser illuminator can also be attached for capabilities of well over 2 miles. Use as a fully operational pocket scope or add a 702 D/S adapter for your Nikon or Canon SLRs or other camcorders. Includes a removable 50mm f/1.3 C-mount lens.



- Built-in tube circuitry protects against bright light damage
- No vignetting
- Dioptic correction from -2 to +6
- Resolution 64 lp/mm
- Brightness increase of 12 to 16 stops
- Built-in IR illuminator
- Power 1- AA or 1- 123
- 100% US made
- Dim. 5 x 2.5"
- Weight: 12oz

#43001	Prowler with 50mm f/1.3 C-Mount	2,994.95
#BE704	3" Extended Viewing Relay Lens	494.95

MEYERS ELECTRO OPTICS 745-B1 Night Vision Systems

Canon XL Series Night Vision Camcorder Kit

The 745B-1 series adapts to Canon XL series (interchangeable lens) camcorders. The 745B-1 includes the relay with designated camcorder adapting bracket mount. The image above illustrates the 745B-1 together with the (optional) Prowler scope, which has a C-mount front and 50mm lens. To adapt the Canon 6x, 16x, and 20x video lenses requires the optional 709A-XI adapter ring



#BE745B1XL Ultra Hi-Res Adaptor f/Canon XL Series camcorders.....**1,995.00**

MEYERS ELECTRO OPTICS 745A Camcorder (Fixed-Lens) Systems

Kits include:

- Camcorder relay
- Designated camcorder bracket (Prowler Pocket Scope optional)



#BE745A-GL	(745A-GL-2) f/Canon GL-1 and GL-2	779.95
#BE745A-XH	(745A-XH-A1/XH-G1) f/Canon XH-A1 and XH-G1	779.95
#BE745A-A1U	(745A-A1U) f/Sony HVR-A1U	779.95
#BE745A-V1U	745A-V1U) f/Sony HVR-V1U	779.95
#BE745A-Z1U	(745A-Z1U) f/Sony HVR-Z1U	779.95
#BE745APD170	745APD170	779.95
#BE745A-VX2100	(745A-PD170/745A-VX2100) f/Sony DCR-VX2100/DSR-PD170	779.95
#BE745A-SR1	(745A-SR1) f/Sony HDR-SR1	779.95
#BE745A-HVX200	(745A-HVX200) f/Panasonic AG-HVX200	779.95

MEYERS ELECTRO OPTICS Camera Adapters/Laser Illuminators

- High-resolution adapters allow you to take pictures in low- or no-light environments by attaching your Prowler Scope to a 35mm SLR camera. Just replace the standard relay lens with this adapter, then mount the assembly to your camera.
- Laser illuminator enhances viewing in total darkness through night vision devices
- Adjustable beam angles
- Includes standard 1/4 x 20" tripod mount



#BEUHRAC	702 D/S-C Ultra High Resolution Adapter for Canon EOS SLR Cameras	1,875.95
#BEUHRAN	702 D/S-N Ultra High Resolution Adapter for Nikon SLR Cameras	1,875.95
#BE424PR14B	Clamp mount	CALL
#BE424R03TSV	Remote pressure switch	CALL
#BE425PA2	200 watt laser illuminator for night vision devices	CALL
#BE425PR14B	Clamp mount	CALL
#BE425R03TSV	Remote pressure switch	CALL



GY-HM100U • GY-HM700U

ProHD Memory Card Camcorders



GY-HM100U

The hand-held GY-HM100 and shoulder-mounted GY-HM700 are solid state 3-CCD camcorders that record 35Mbps HD video and uncompressed audio directly to SDHC media cards in the native Quicktime format used by Apple Final Cut Pro. This eliminates the need to transcode or re-wrap prior to editing — allowing instant editing of recorded material without file conversion, and a media cost approaching the economy of tape. Video clips are dragged directly from the storage media onto the editor's timeline, eliminating the need for transcoding while maintaining original first generation image quality.

In addition to 35Mbps per second, a bit rate supporting full 1920 x 1080 encoding in the HQ mode, they can record 720p (19/35Mbps) and 1080i (25Mbps) in SP mode, assuring compatibility with most NLE systems. Both record on SDHC memory cards up to 32GB. The cameras have two memory card slots, for a total of up to 64GB of on board storage—enough for up to 6 hours of continuous HD recording. The cameras automatically record on the second card when the first card is full.



GY-HM700U

GY-HM100 Hand-held

- Ultra-compact handheld form factor makes it ideal for use in tight quarters. For even less conspicuous shooting, the handle can be removed and the audio can be recorded via the built-in 2-channel mic.
- Incorporates a Fujinon 10:1 Zoom HD Lens with three aspherical elements and an EBC for reduced flaring and ghosting. Flip-in cover integrated in the lens hood, eliminates the need for an external cap.
- Focus is controlled manually or automatically. A smooth servo zoom is controlled with a rocker on the handgrip, or manually with the lens ring. Macro mode lets you record subjects as little as 2" away from the lens. Automatic and manual iris let you adjust the depth of focus.
- Camera's hand grip accommodates hands of all sizes. A single ring is used for both manual focus and manual zoom. Additional manual controls include white balance, shutter, gain, and audio levels.
- Audio levels can be controlled manually, or automatically using AGC. Audio meter in the LCD and VF facilitates adjustment. Balanced XLRs with 48v phantom power on the handle for external mic and/or wireless receiver. Shotgun mic is provided, as well as a built-in stereo mic for ambient sound pickup.

GY-HM700 Shoulder-Mounted

- Utilizes three precisely aligned 1/3" progressive scan full HD CCDs and exclusive Adaptive Pixel Correlation Technique to produce resolution comparable to cameras with larger image sensors.
- Includes a detachable 14x Canon HD lens based on the superb optics found in more expensive HD lenses. Its superior MTF provides higher resolution than typical "stock" lenses.
- Create a single clip file from multiple trigger presses. This is ideal when "in camera editing" is preferred. The complete shot sequence is instantly available as a single clip.
- Optional adapters allow 1/2" and 2/3" bayonet mount lenses to be used. Optional HZ-CA13U film lens mount adapter enables mounting of 16mm film camera lenses—expanding production lens options.
- In 720p 35Mbps mode, the camera can be set to record at a frame rate different (under/over crank) than the playback rate.

GY-HM100U (JVGYHM100) and GY-HM700U (JVGYHM700U) Call or Log-on

GY-HD250U 1/3" 3-CCD Professional ProHD Camera

Designed for ENG, field production and cinematography, the GY-HD250U records full-frame 720/60p and real 24p, 25p, 30p, 50p, and 60p. Offers 24p full HD image capture for cinematographic applications and easy transfer to 16mm and 35mm film. 1280 x 720 HDV format produces crisp, native HD images, while full-frame 60p eliminates the degenerative process of de-interlacing. MPEG-2 compression allows high-quality HD recording on standard DV media. Direct digital transfers to HDD via FireWire maintain quality throughout the transfer process. Archive on tape or plug the drive straight into an NLE—no need to make dubs or transfer data.



- Composite video input (for SD pool feed) , genlock, time code input/output
- Studio capability with optional multicore adapter
- HD/SD-SDI output with embedded audio & TC, Varicam flags (HD mode only); HD-SDI output of 1080i from built-in cross converter

GY-HD250U with 16x Fujinon Lens (JVGYHD250U) 5995.00

GY-HM790U ProHD ENG / Studio Camera

The GY-HM790U is a modular 3-CCD shoulder-mount HD video camera with solid state recording capability as well as studio functionality. Capable of recording 1920 x 1080 (60i, 50i, 30p, 25p, 24p), 1440 x 1080 (60i, 50i (MOV only), 1280 x 720 (60p, 50p, 30p, 25p, 24p) at 35Mbps or 19 Mbps and 720 x 480i video to native MP4 or Final Cut Pro files for the most efficient workflow. Also offers a full complement of broadcast features, including HD-SDI output, 4:2:2 sampling, timecode, genlock, and variable frame rates. Records to dual, hot-swappable SD/SDHC cards which can be coupled with the optional KA-MR100G SxS recorder for extended or backup capture, or simultaneous recording to high-speed SxS media. Optional studio components allow the camera to meet the most demanding studio applications.



- With full recording compatibility with the following formats, users can take advantage of accelerated workflow enabled through Native File Recording capability.
 - QuickTime™ MOV, native file format recording (HD/SD) for direct file access to Apple FCP
 - XDCAM EX MP4 (HD), Seamless integration into XDCAM EX™ HD workflow
 - AVI (SD), DV codec AVI file support for existing SD workflow
- When recording in 720p 35Mbps mode, the camera can be set to record at a frame rate (10, 12, 15, 20, 24, 30, 40, 48 or 60 fps) different than the playback rate (overcrank/undercrank). This makes it possible to record slow or fast motion when the recording is played back at 24p or 30p.
- Stunning high-resolution (852 x 480 x 3) LCOS 0.45" 16:9 viewfinder is crisper and more detailed than conventional LCD viewfinders, with higher vertical resolution and superior RGB color separation. Helping the operator stay focused on the action is a focus assist system that highlights the edges of objects in the image. Also visible in the viewfinder are indicators for the audio input level, the battery time remaining, and the recording time available on each memory card.
- 4.3-inch (800 x 480) 16:9 LCD monitor provides a wide array of monitoring and setup indications.
- SD composite, HD/SD component, SDI and IEEE1394 outputs. The SDI output (BNC) can be switched between HD and downconverted SD with embedded uncompressed audio.
- When shooting high-contrast scenes, the camera features a spot exposure meter to monitor the dynamic range of the image in various ways so that the exposure may be controlled more accurately.

GY-HM790 Body (no lens) (JVGYHM790CHU) 8795.00

Optional Studio Components:

KA-M790G Multicore Studio Interface: Small and compact unit enables studio/EPF operation. Features intercom, call camera control, video/genlock, tally and other signals interface via 68-pin multi-connector. Has a 26-pin RM connector on the back compatible with cables from JVC and Sony to connect with a camera control unit (CCU). (JVKAM790G) **2495.00**

KA-790G Studio Sled: Supports the VF-HP790 LCD studio viewfinder on the top and stabilizes the entire system including an optional teleprompter. A hinged side panel makes it easy to remove the camera for shoulder use. (JVKA790G) **1995.00**

VF-HP790G LCD Studio Viewfinder: 8.4" XGA (1024 x 768) LCD studio viewfinder for the GY-HM790 or GY-HM700. Mounting to the KA-790 Studio Sled, it is equipped with a large tally indicator and screen hood. Provides all of the camera's viewfinder indications: safety markers, focus assist, power and clip management. Also has an HD-SDI input for monitoring an external signal. (JVVFHP790G) **3895.00**

SR-HD1250 • SR-HD1500 Blu-Ray and HDD Recorder Combos

Record and author professional BDMV (with menu) or BDAV discs. Advanced MPEG-2 and MPEG-4 encoding provides support for HD and SD



sources, and a built-in format converter can downconvert HD content for recording to a standard DVD. They also support BD-R or BD-RE (erasable) Blu-ray discs. The SR-HD1250 has a 250GB hard drive and includes component and HDMI outputs for flexible monitoring options. The SR-HD1500 steps up with a 500GB hard drive, RS-232C and support for .MOV files (for Apple Final Cut Pro), making it compatible with footage recorded with the JVC GY-HM100, GY-HM700 in the SP mode.

- USB, SDHC slot and i.LINK input for connection to camcorders
- Multiple file formats such as AVCHD, HDV, DV are compatible; digital dubbing can be performed.
- Copy videos to a Blu-ray disc from HD camcorder, from the HDD, or downconvert videos and record them onto a DVD. The internal HDD also enables easy editing and dubbing of multiple discs.

SR-HD1250 (JVSJRH1250US) and SR-HD1500 (JVSJRH1500US) Call or Log-on

Panasonic

AW-HE100

Multiformat HD/SD Integrated PTZ Camera

The HE100 integrates super-smooth pan/tilt/zoom (PTZ) mechanisms within a unique ergonomic design, making it a cost-effective robotic camera solution for a wide range of applications—from surveillance to video-conferencing to event production. The HE100 supports 1080i, 720p, and 480i formats and can simultaneously output both HD and SD signals, creating broadcast-quality video through its three 1/3" CCD's and 13x f1.6 zoom lens. The integrated PTZ unit has a True Servo pan-tilt head that offers precise, fast, fluid movement in all directions, delivering a maximum pan/tilt speed of 60 degrees per second. Outputs HD/SD analog component and composite video. Includes: Wireless remote control, power cable, tbletop/ceiling mounting bracket, main mounting bracket, drop-prevention wire, cable cover, mountig screws and rubber feet.



AW-HE100 (#PAAWHE100) **Call**
HD/SD-SDI Output Board (#PAAWHD100) **Call**

AW-HE50H • AW-HE50S

Multiformat HD/SD Integrated PTZ Cameras

The AW-HE50H and AW-HE50S combine outstanding image quality, smooth pan/tilt/zoom operation and easy integration for superior HD/SD production and communications. They feature full HD 1920 x1080 MOS sensor and support 1080i, 720p, 576i and 480i. They can be controlled via RS-422 or Internet Protocol (IP) via 3rd party control or automation systems or via computer. Up to 100 HE50's can be operated by the Panasonic AW-RP50 remote camera controller. Otherwise the same, the HE50H has an HDMI output making it ideal for HD videoconferencing and distance learning; the HE50S has HD/SD-SDI output and genlock, making it a great choice for multi-camera systems and for demanding applications such as TV/cable production, sports video, A/V and conference facilities, houses of worship, and professional staging applications.

- High-quality 18x HD optical zoom lens, plus a 10x digital zoom.
- Dynamic Range Stretch (DRS) enables multi-zone digital image processing over a wide dynamic range, for exceptional results in difficult shooting conditions.
- Hybrid Noise Reduction function reduces noise without image latency or loss of resolution by combining 3D and 2D noise reduction algorithms.
- "Flesh Tone" function enables accurate and pleasing reproduction of live subjects.
- Smooth and highly accurate pan-tilt head offers precise, fast, fluid movement in all directions (±175° pan; +90° to -30° tilt). These capabilities enable the capture of a wide range of slow and fast moving objects without visually distracting vibration or "bounce". Moreover, the unit delivers quiet operation.
- Also feature 3-step gamma correction, 7-step chroma level adjustment, 100 pre-set memories, up to 1/10,000 electronic shutter with synchro scan, tally light, and a ceiling mounting bracket.



AW-HE50H with HDMI output (#PAAWHE50H) **Call**
AW-HE50S with HD/SD-SDI (#PAAWHE50S) **Call**
AW-HS50 Compact Live Switcher (#PAAWHS50) **Call**
AW-RP50 Remote Camera Controller (#PAAWRP50) **Call**

Panasonic

AG-DVX100B 1/3" 3-CCD MiniDV Camcorder

The lightweight AG-DVX100B records in standard definition 60i or 30p or lets you achieve film-like images with 24p shooting and Panasonic's exclusive CineSwitch™ technology. Adjust every aspect of your picture, with manual control of iris, shutter, gain, white balance, gamma, color matrix, detail, chroma, and pedestal. Three user-assignable buttons and six scene files allow you to save settings and transfer them between projects. Leica Dicomar 10x wide-angle zoom lens provides mechanical zoom and focus rings for precise control, along with professional barrel markings for correct pull-focus and take-to-take consistency. To make sure you're seeing exactly what you're shooting, a BW/color viewfinder and LCD both offer full overscan and anamorphic 16:9 display. Also offers two zebra settings, and has two XLR audio inputs.



Shown with optional Mic

AG-DVX100B (#PAAGDVX100B) **Call or Log-on** **AG-DVX100B in 'PAL' (#PAAGDVX100BP)** **Call or Log-on**
63-Minute High-Definition MiniDV Tape (#PAAYDVM63HD) **7.99**
63-Minute Advanced Master-Quality MiniDV Tape (#PAAYDVM63AMQ) **5.69**
Extended 7.2v 5400mAh Lithium-ion Battery (#PACGRD54) **115.95**
Power Adapter / Battery Charger (#PAAGB25) **142.95**
72mm 0.8x Wide-Angle Lens (#PAAGLW7208G) **389.95** **72mm Anamorphic Lens Adapter (#PAAGLA7200G)** **729.95**

AG-DVC20 3-CCD MiniDV Proline Camcorder

Shoulder-mounted SD camcorder with an advanced digital image processing system that captures sharp and vivid images with true colors. Perfect for educators, event videographers, sports coaches and entry-level shooters, the camera is equipped with three 1/6" CCD's, 10x optical zoom lens with electronic image stabilization, multi-speed zoom rocker and 2.5" LCD monitor. Lightweight (4.4 lb.) and easy to use with a one-touch navigation joystick for easy and fast control over basic operations. Different shooting modes—Cinema (letterbox), tele-macro, and soft skin—and five AE settings give you more advanced image control, while the Color Night View mode produces bright, vivid colors even in dimly lit locations. IEEE-1394 input and output, plus composite and S-Video output. Built-in stereo microphone and external stereo mini-mic input. Includes two 1350 mAh batteries, AC adapter and wireless remote control.



(#PAAGDVC20) **Call or Log-on**

AJ-HDX900 2/3" 3-CCD 16:9 1080i/720p DVCPRO HD Camcorder

The AJ-HDX900 is a full 2/3" DVCPRO tape-based HD camcorder that records pristine 100Mbps HD images in any of 11 video formats, encompassing 60Hz and 50Hz production. Provides higher-quality 4:2:2 intra-frame recording that holds up through layers of special effects, graphic overlays and constant editing and processing. With 1080i, 720p, 24p and 25p capabilities, the AJ-HDX900 is perfect for long-form HD programming and an invaluable tool for digital cinematography, cable and television production in any format, sports, events and documentaries.

- Three CineGamma modes to replicate the look and feel of film
- Supports 1080 at 59.94i, 50i, 29.97p, 25p, 23.98p, 23.98pA and 720 at 59.94p, 50p, 29.97p, 25p, 23.98p
- HD-SDI output plus built-in downconverter to produce an SD output; IEEE1394 digital output
- Outstanding low-light shooting down to 0.032 lux (at +62 dB gain)



PAAJHDX900 **Call or Log-on**

AJ-SD930B DVCPRO 50/25 Editing VCR with DVCAM and DV Playback

The AJ-SD930B is a versatile, cost-effective studio VCR designed for high-end digital video production. Use of the DVCPRO50 50Mbps format makes it suitable for creating high-end programming. With 4:2:2 digital component recording and four channels of digital audio, it delivers the superior picture and audio quality professionals need. Equipped with SDI I/O, RS-422A remote and jog & shuttle dial. Switchable between DVCPRO50 (50Mbps) and DVCPRO (25Mbps) for recording and playback. In DVCPRO50 mode records up to 92 minutes on a AJ-5P92LP 1/4" cassette tape. In DVCPRO mode, recording time is doubled. Also plays back DVCAM and standard DV tapes. Mini DV tapes can be played back using the optional AJ-CS455P adapter. In playback mode, it automatically detects the recording format used (DV, DVCAM, DVCPRO or DVCPRO50) and plays accordingly.



PAAJSD930B **Call or Log-on**

AJ-HD1400 DVCPRO HD-EX VCR with DVCAM and DV Playback

From field recording to nonlinear to studio editing, the AC/DC-powered AJ-HD1400 is an invaluable solution for HD production. It records at 100 Mbps with 4:2:2 color sampling and intra-frame compression in multiple HD/SD formats including 1080/59.94, 1080/50i, 720/60p, 720/59.94p and 720/50p. Features HD-SDI and IEEE1394 input/output, RS-422 interface and a built-in up/down converter. Lightweight, the AJ-HD1400 offers a handle for on-the-go use and its compact design makes it a great space-saver for desktop use and in-studio editing.



#PAAJHD1400 **Call or Log-on**

AVCCAM ACCESSORIES

For AG-HMC40

7.2v 5800mAh Lithium-ion Battery (PAVWVBG6PPK).....149.95

For AG-HMC70

Soft Case with 3" hood for LCD (PAAGYUC70H)164.95

Hard Shell Case: Yellow, Hard Shell Case by Thermodyne (PAAGYUC70)198.95

MC-70 Shotgun Microphone (PAMC70)219.95

43mm 1.4x Telephoto Lens (PAVWT4314H).....179.95

7.2v 2640mAh Lithium-ion Battery (PAVWVBG260PQ)....149.95

7.2v 5400mAh Lithium-ion Battery (PAVWVBG6PPK).....149.95

For AG-HMC150

MC-70 Shotgun Microphone (PAMC70)219.95

7.2v 2640mAh Lithium-ion Battery (PAVWVBG260PQ)....149.95

7.2v 5400mAh Lithium-ion Battery (PAVWVBG6PPK).....149.95

Panasonic AG-HMC40

3-Chip AVCCAM Handheld Camcorder with 10.6MP Still Capability

Weighing less than 2.2 pounds, the AG-HMC40 features three full resolution 1/4" 3-MOS image sensors to produce stunning 1920 x 1080 HD images with high sensitivity. The camera can also capture still images with 10.6 MP resolution directly onto the SD card. It is equipped with a 12x optical zoom (includes 2x, 5x, 10x) and professional image functions like Dynamic Range Stretch (DRS) that helps compensate for wide variations in lighting, and a Cine-Like Gamma mode which gives recordings a more film-like aesthetic.



- Supports 1080/59.94i (in all modes) and 1080/29.97p, 1080/23.98p native, 720/59.94p, 720/20.97p, and 720/23.98p native (in PH mode only).
- Offers a wide variety of valuable professional features including waveform monitor display, focus assists such as focus bar display and enlarged display, time date stamp, user assignable focus ring, auto focus with face detection, zebra display, synchro-scan shutter function, three programmable user buttons, time code/UB recording, and remote control terminal (for zoom, focus, aperture, REC start/stop controls).

- Comes standard with HDMI output, USB 2.0, composite output (AV multi/ch1, ch2), analog component (mini-D), detachable XLR audio input and audio REC level adjustment dials. Also offers 2-channel input (mic/line switchable) with +48V phantom power.
- 2.7" LCD monitor offers simple touch-panel operation and access to various solid-state recording functions such as pre-record, interval recording, shot marker and metadata capture.

AG-HMC40 (PAAGHMC40)Call or Log-on

Panasonic's AVCCAM series provides the flexibility of low cost, SD memory card based recording and full 1080 and 720 resolution capture. Utilizing AVCHD, an MPEG-4 /AVC Hi Profile-based format, the AVCCAM series provides a near doubling of bandwidth efficiency with improved video performance over MPEG-2 compression used in HDV formats. It also brings the benefits of solid-state recording to budget-conscious professionals. Like digital still photography, recording onto inexpensive SD/SDHC cards offers a fast and simple, file-based workflow with ultra-reliable performance and resistance to shock, vibration and extreme temperatures and weather. Since AVCHD records video as digital data files, content can be transferred and stored on affordable, high-capacity hard disk drives (HDD) or optical storage media and transferred to future storage media as technology advances.

- Using just one 32GB SDHC memory card, a user can record 3 hours of full resolution 1920 x 1080 video and audio in PH mode (average 21 Mbps/max. 24 Mbps), four hours at HA mode (17 Mbps) and 5.3 hours at HG mode (13 Mbps). In the HE mode (6 Mbps), the camera can record up to 12 hours of 1440 x 1080 HD content on a single 32GB SDHC card.

- AVCHD is supported by a wide range of editing options including Apple Final Cut Pro, Adobe Premier Pro CS4, EDIUS Pro 5 and EDIUS Neo 2. In addition, a free transcoder can be downloaded from Panasonic to convert AVCHD files to DVCPRO HD P2 and downconverted DV files for use with most existing professional editing systems.

Panasonic AG-HMC80

3-Chip AVCCAM Shoulder-Mount HD Camcorder

With a high-resolution 3-megapixel imager, four AVCCAM HD recording formats, 12x optical zoom (40.8-490mm equivalent) DV support, and enhanced professional functions, the AG-HMC80 delivers the full benefits of AVCCAM for schools, event videographers, government and corporate users who prefer to work with a shoulder-mount camera and need flexible connectivity and format support. The camera, utilizing a professional 3-chip imager, can also take 10.6-megapixel still images and store them as standard JPEGs on the solid state card. AVCHD recordings and stills can be played back from the SD card on Blu-ray players, laptop PCs and advanced game consoles.



- 3-megapixel 3MOS imager produces stunning 1920 x 1080 or 1280 x 720 AVCHD video with high sensitivity. Plus, using MPEG-4 AVC/H.264 high profile encoding – recordings look clean and crisp, even during fast motion, without image degradation or dropouts.
- At 60Hz, the camcorder supports the following HD formats in PH mode: 1080/60i, 1080/30p, 1080/24pN, 720/60p, 720/30p, 720/24pN; in HA, HG and HE modes, it records in 1080/60i.
- Record DV (480/60i, 480/30p, 480/24p) on SD cards with squeeze, letter box and side crop options.
- User-assignable manual focus ring (Focus/Iris/Zoom) for added control; time code/UB recording; time/date stamp; no wired remote control terminals (for zoom, focus, iris, REC start/stop controls).
- Optical Image Stabilizer (OIS) for smooth stable shooting; Dynamic Range Stretch (DRS) compensates for wide variations in lighting, and a Cine-Like Gamma mode to give recordings a more film-like look.
- Two XLR inputs (mic/line) with +48v phantom power, built-in stereo mic, and external mic-in jack. Also HDMI output, USB 2.0, composite (BNC), analog component (BNC x3), and IEEE1394 output.
- Offers waveform monitor display, focus assists such as focus bar display and enlarged display, auto focus with face detection, zebra display, color bar, tally lamps, slow smooth zoom and soft landing, slow shutter and synchro-scan shutter functions, and three programmable user buttons.

AG-HMC80 (PAAGHMC80).....Call or Log-on

Panasonic AG-HMC150

3-Chip AVCCAM Handheld HD Camcorder

The AG-HMC150 is a production-level camera featuring three 1/3" progressive CCD imagers to produce stunning 1920 x 1080 resolution picture quality. It comes with a 13x Leica Dicomar zoom lens (28-364mm equivalent)—the widest in its class, auto or manual operation of focus and iris, and automatic optical image stabilization (O.I.S.) to ensure stable, smooth and precise shooting. It handles full-pixel (1920 x 1080 and 1280 x 720) 24p progressive recording, and offers advanced features such as SMPTE time code reader/generator, focus assist functions, six scene files, three neutral density filters and three user sets and simplified waveform and vectorscope display.



- Cam-driven (mechanical) manual zoom ring provides the same fast, precise zooming and feeling as cameras with interchangeable lenses. The servo-driven zoom also allows slow zooming. Also offers a 2x, 5x or 10x digital zoom that instantly magnifies the image —without the light loss that happens when using a lens extender.
- Records in 1080/60i, 1080/30p, 1080/24p; 720/60p, 720/30p, 720/24p HD formats
- Advanced gamma functions address eight shooting scenarios and enhance your creative abilities. This includes the cinelike gamma, which produces the characteristic warm tone of film recordings.
- In addition to a built-in stereo mic, it has two XLR mic/line switchable inputs with +48v phantom power, auto/manual level, and internal/external assignment
- Equipped with both composite (RCA) and component (Mini D4) video outputs, allowing HD images to be down converted and output as SD images. Also has an HDMI output and USB port.
- Any remote controller compatible with the AG-DVX100 or AG-HVX200 can be used (for Zoom, Iris, Focus, Start/Stop)
- Handle grip contains both the Rec Start/Stop button and a lens zoom control (with three speeds) to ensure easy shooting even at low angles.
- Large 3.5" LCD monitor offers a monitor mirror mode which is convenient when shooting interviews.
- Time/date stamp for applications like legal depositions or surveillance

AG-HMC150 (PAAGHMC150).....Call or Log-on



AG-HPX170 1/3" 3-CCD P2 HD Handheld Camcorder

The AG-HPX170 is a solid-state P2 HD handheld camcorder equipped with three 1/3" 16:9 CCDs, high-performance digital signal processor with 14-bit A/D conversion and 19-bit processing to assure high-quality recordings necessary for top-level production and broadcast. Weighing only 4.2 lbs, the camcorder has a 13x Leica Dicomar zoom lens with a 28mm wide-angle setting (the widest in its class) and a cam-driven manual zoom for smooth, easy and precise operation. For added flexibility, the camera provides auto or manual focus and iris.



- Fully solid-state, the HPX170 has no moving parts, features fast IT compatible file-based workflow, and is resistant to temperature extremes, shock and vibration.
- Two P2 card slots let you record up to 128 minutes of the highest quality DVCPRO HD recording using 64GB P2 cards. Other user-friendly recording modes include hot swapping for non-stop recording, loop record, pre-record, interval and one-shot recording. A time/date stamp function makes it ideal for use in law enforcement environments.
- 20-step frame rate selection in 720p mode for variable-speed shooting in the 12 fps to 60fps range to acquire fast- or slow-motion in-camera effects.
- For added creative flexibility, offers a variety of advanced gamma functions and settings including a CineGamma mode.
- HD/SD-SDI output for live feed, editing and monitoring. Also has IEEE1394 and USB 2.0 interfaces.
- Records in 20 HD and SD formats (1080i and 720p formats in DVCPRO HD, as well as 480i in DVCPRO50, DVCPRO and DV) and is switchable between 16:9/4:3 aspect ratios.
- Convenient features include clip preview on the camera's 3.5" color LCD monitor; instant recording startup, scene files, assignable user buttons, focus assist and a camera remote function.

AGPAHPX170 **Call or Log-on**

AG-HVX200A

1/3" 3-CCD P2 HD/DV Handheld Camcorder

This solid state P2 HD/DV camcorder provides professional filmmakers with a powerful acquisition tool for the most demanding requirements. 1/3" 16:9 progressive 3-CCD imager and a wide-angle (30mm) 13x Leica Dicomar HD lens give you a wider, more vibrant image as you capture HD 1080i and 720p video in DVCPRO HD, DVCPRO 50, DVCPRO or DV. The HVX200A's intraframe compression system—great for precise editing—records to two P2 cards 64 mins. per 64GB card) or MiniDV tape at 100 Mbps and 4:2:2 sampling. With Cine/News gamma modes, plus variable frame rates of 12–60fps, achieve the exact look your project needs. Also offers uncompressed 4-channel, 16-bit digital audio recording in DVCPRO HD and DVCPRO50SD, built-in SD downconverter, two XLR inputs with Phantom power and analog component signal terminals, IEEE1394 and USB 2.0 ports and SD Memory card slot. Includes full function remote control.



PAAGHVX200A **Call or Log-on**

Optional Accessories for the AG-HPX170 and AG-HVX200A

- Rep. Lithium-ion Battery Pack:** 7.2v, 5400mAh (PACGRD54) .. **134.95**
- 16GB E-Series** P2 Memory Card (PAAJ/P2E016XG) **399.95**
- 32GB E-Series** P2 memory card card (PAAJ/P2E032XG) **569.95**
- 64GB E-Series** P2 memory card card (PAAJ/P2E064XG) **899.95**
- 60GB** Portable P2 Storage Device (PAAJ/PCS060G) **1469.95**
- MC-70 Shotgun Mic:** Supercardioid polar pattern for off-axis rejection and focused pickup. The mic can be boom or stand mounted and is ideal for ENG work. Has an XLR output and +48V Phantom power is required. (PAMC70) **219.95**



Camera Rain Cover (for AG-HVX200A):

Protects the camcorder from rain, dust and poor weather conditions, while allowing full operation. There are extra-large clear vinyl windows to view camera controls and cassette opening with a microphone opening, pockets for a viewfinder and a wireless receiver antenna. It has an opening for a sungun and is equipped with a thermoforming gasket to keep out dampness. This rain cover is contoured to protect flip-out monitor screens. (PAAGYURC100) **86.95**



AG-HPX370 P2 HD Camcorder with AVC-Intra

Equipped with 17x interchangeable lens, three 1/3", full-HD 2.2 megapixel U.L.T. 3-MOS imagers and 20-bit Digital Signal Processor, the AG-HPX370 acquires full 1920 x 1080, 10-bit 4:2:2 AVC-Intra recording to bring true master-quality HD recording – with the benefit of P2's fast independent frame, file-based workflow. Delivers high-resolution recording using AVC-Intra and DVCPRO HD, but also supports SD recording in DVCPRO50, DVCPRO and DV formats for complete flexibility. Native 24p (23.98 fps), makes it an affordable solution for indie film production. Lightweight (only 8 lbs.) with a well-balanced design, the AG-HPX370 offers a broad range of creative features including variable frame rates, advanced gamma functions, Chromatic Aberration Compensation (CAC), built-in scan reverse, Dynamic Range Stretch (DRS) function, waveform and vector scope display and focus assist tools. High-res LCOS color viewfinder (1,226,000-pixels) and 3.2" LCD color monitor (921,000-pixels) provide clear image reproduction even in bright outdoor areas. The two-slot HPX370 provides instant random access to recorded HD or SD content and operates reliably in harsh environments, with resistance to temperature extremes, shock and vibration. (PAAGHPX370) **Call or Log-on**



AG-HPX500 2/3" 3-CCD P2 HD Camcorder

With three 2/3" progressive image sensors, an interchangeable lens system and four P2 card slots, the AG-HPX500 is built for professionals. Supporting all HD/SD recording formats and tapeless P2 work flow, it uses advanced 14-bit A/D digital conversion and 19-bit inner processing for exceptional image accuracy. It records in 1080 (60i/50i/30p/25p/24p) and 720 (60p/50p/30p/ 25p/24p) resolution, with a variable frame rate function (12fps–60fps) that allows for under- and overcranking. Footage can be captured in DVCPRO HD, DVCPRO50/25, and DV, in a variety of gamma modes, while exclusive CAC technology minimizes any blur caused by lens chromatic aberration. Offers instant recording startup, clip thumbnail view, shot marker, hot swap, pre-rec, loop-rec and SD card metadata/scene files.



AG-HPX500: with 1.5" B/W viewfinder (PAAGHPX500) **Call or Log-on**

AG-HPX500: with Canon 17x 2/3" Motor Drive Full-Servo Lens (KJ17ex7.7B ITS-ME) and two 32GB P2 cards (PAAGHPX500K1) **Call or Log-on**

AJ-HPX2000 2/3" 3-CCD 16:9 P2 HD Camcorder

The AJ-HPX2000 integrates native HD progressive 2/3" 3-CCD performance with the ultra-high reliability and speed of P2 solid-state recording. An incredibly flexible, full production-quality camera, it can record pristine high-quality images in over 30 HD and SD formats ranging from 1080p, 1080i, 720p, 480p, 480i and 576i. With the AVC-Intra codec option board (AJ-YBX200G), the AJ-HPX2000 can deliver 10-bit, 4:2:2 master-quality video for outstanding video production and news acquisition. Extensive signal connectivity and control capability includes IEEE1394 (AVC) and USB 2.0 interfaces, HD/SD-SDI, genlock, SMPTE time code and composite video. A 10-pin RCU terminal connects the optional AJ-RC10G remote control unit. GPS mapping connection is also available. Features high sensitivity of F11 at 2000 lux and a minimum illumination of 0.007 lux (at +74 dB gain), powerful digital super gain, time lapse, 12-color correction matrix for precise color adjustments. Records 48-kHz/16-bit digital audio on four channels. Holds up to five 64MB P2 cards to record over 10 hours of content with AVC-Intra 50 and over 13 hours in DVCPRO HD 720p native.



- AG-HP2000 Body only:** No lens or viewfinder or lens (PAAJ/HPX2000) **Call or Log-on**
- 2" HD B&W Viewfinder** (PAAJ/HVF21G) ... **3995.00**
- Tripod Adapter** (PASHANTM700) **444.95**
- Stereo Mic** (PAAJ/MC900G) **1473.95**
- Mic Holder** (PAAJ/MH800G) **304.95**
- GPS Global Positioning Unit** (PAAJ/GPS910G) **1259.95**
- AVC-Intra Codec Board** (PAAJ/YBX200G) and **HD/SD Input Board** (AJ-YA350G) **Call or Log-on**



AJ-PCD2 Single-Slot P2 Solid-State Memory Card Drive

Basically a P2 card reader, the AJ-PCD2 supports all P2 card sizes, P2 formats and frame rates in HD and SD for fast, reliable video offloads. Supplied with two USB 2.0 cables, the PCD2 requires no separate power supply for file transfers and offers total compatibility with Mac OS X and Windows desktop and laptop computers.

(PAAJPCD2).....**Call or Log-on**



AJ-PCD20 • AJ-PCD35 5-Slot P2 Card Drives

These P2 Drives are conduit between P2 cards and a computer. When connected to your computer, the P2 cards appear as one drive. The AJ-PCD20 can ingest up to 5 P2 cards at one time over FireWire or USB 2.0. When connected to either a Mac or PC the P2 cards will appear as one drive, making it extremely easy to browse through video footage. For even faster data transfer, the AJ-PCD35 drive can also ingest up to five P2 cards at once. However, it connects via a "PCI-e" card slot of a tower computer to support a peak transfer speed of up to 1.2 Gbits/sec. This is 3x faster than USB 2.0 and 1.5x faster than Firewire/1394b.

AJ-PCD20 (PAAJPCD20).....**Call or Log-on** **AJ-PCD35** (PAAJPCD35).....**Call or Log-on**



AG-MSU10 Portable P2 Media Storage Unit

Easily back-up or aggregate P2 content to a large removable solid-state drive. This allows users to quickly download P2 content, and then walk away with a featherweight SSD unit that can be powered by virtually any computer. Delivering fast, stable data transfer, the compact AG-MSU10 eliminates the need for computers or larger, more expensive appliances in the field and frees up card space for additional shooting. Battery operated, the compact AG-MSU10 has two slots: one for a P2 card, and the second for the AG-MBX10 removable housing that encloses a standard 2.5" SATA solid-state drive (SSD). Equipped with USB 2.0 and eSATA connectors, the drive can then be connected to PC or Mac. Has a 3.2" LCD screen for simple one-touch operation. It provides P2 thumbnail display and supports master-quality 10-bit AVC-Intra (100/50) and DVCPRO HD, DVCPRO50, DVCPRO and DV recording formats. Content is transferred from a P2 card to the solid-state drive at 4x real-time when recording in AVC-Intra 100 or DVCPRO HD. (PAAGMSU10) (no SSD included)**Call or Log-on**



AJ-HRW10 Portable P2 Rapid Writer

The AJ-HRW10 lets you copy content from up to five of your P2 cards onto two 3.5" removable SATA drives configured for RAID-1 mirrored operation. This lets you reuse your P2 cards on the next shoot while knowing that your previously recorded footage is safely stored away in its original pristine format. You can also configure the drives as JBOD if more storage space is needed rather than fail-safe backup. Supports all P2 frame rates, formats and codecs (AVC-Intra 100/50, DVCPRO HD/50/25/DV), and offers simple VCR-like controls. All system information is displayed on the 5" LCD monitor, including playback status from disk drives, assuring your data was successfully copied over. Equipped with a Gigabit Ethernet port for network integration, and speakers and a headphone jack for audio monitoring. Removable hard disk drives, power supply, rack enclosures and rack slides are not included (available separately). (PAAJHRW10)**Call or Log-on**



AG-HPG20 Portable P2 Player/Recorder

Featuring AVC-Intra recording, the powerful, 2.5 lb. AG-HPG20 brings easy playback, recording and file copying of 10-bit, 4:2:2 content to field and studio work. Equipped with two P2 card slots and a 3.5" LCD monitor, the P2 lets you view content in a variety of formats — whether it's 10-bit, 4:2:2 AVC-Intra or DVCPRO HD or in standard definition in DVCPRO50, DVCPRO and DV. Professional inputs/outputs include IEEE1394, USB 2.0 and HD-SDI). Shock-resistant and solid-state, the recorder features a wide range of clip playback and management functions (including metadata editing), speakers and easy-to-use controls. (PAAAGHPG20)**Call or Log-on**



AG-3DA1

The AG-3DA1 is a professional, fully-integrated Full HD 3D camcorder that records to SD card media. It makes 3D production more democratic by giving professional videographers an affordable, flexible, reliable and easier-to-use tool for capturing immersive content as well as providing a training tool for educators.

At less than 6.6 pounds, the AG-3DA1 is equipped with dual lenses and two full 1920 x 1080 2.07 megapixel 3-MOS imagers to record 1080/60i, 50i, 30p, 25p and 24p (native) and 720/60p and 50p in AVCHD. It can record for up to 3-hours on dual 32GB SD cards in Panasonic's professional AVCHD PH mode, and offers dual HD-SDI outputs, HDMI (1.4) interface, two XLR connectors, built-in stereo mic and twin-lens camera remotes. It also features a remote terminal for focus iris, zoom, REC start/stop and convergence point. Its 3.2-inch LCD screen provides the option to switch from Left, Right or overlay image display.

- The AG-3DA1 incorporates stereoscopic adjustment controls making it easier to use and operate. The twin-lens system adopted in the camcorder's optical section allows the convergence point to be adjusted. Functions for automatically correcting horizontal and vertical displacement are also provided. Conventional 3D camera systems require these adjustments to be made by means of a PC or an external video processor. The AG-3DA1 however, will automatically recalibrate without any need for external equipment, allowing immediate 3D image capture.
- The AG-3DA1 is lighter weight and smaller than current 3D rigs, while providing the flexibility of handheld-style shooting. Setup and transportation is simplified, making it ideal for sports, documentary and filmmaking projects.
- Right and left Full HD video streams can be recorded on SDHC/SD Memory Cards, significantly reducing maintenance costs.

AG-3DA1**Call or Log-on**



AG-HMX100 3D Compatible Digital AVV Mixer

The AG-HMX100 is a compact, all-in-one, digital AV mixer with a built-in HD/SD multi-format compatible video switcher, audio mixer, frame synchronizer and digital effector. It serves as an audio/video switcher, adds a variety of effects, and transmits signals - all by itself. A Multi-View function displays all source images on a single monitor, while keeping the system configuration simple and clean. Users benefit from easy delivery, set-up and removal at event sites, as well as low-cost operation. Wide-ranging SDI (HD/SD), PC (DVI-I) and HDMI (HD only) inputs, versatile digital effects, and comfortable Matrix Menu operation combine with advanced functions to configure a low-cost system that supports a wide variety of applications, from live relays and broadcasting to production. The AG-HMX100 can also operate as a 3D video switcher with dual SDI inputs. Combined with the Panasonic AG-3DA1 3D HD cam corder, and the 3D-compatible BT-3DL2550 LCD Video Monitor, which lets you view 3D footage on-site, this professional HD 3D production system makes it easy to produce and transmit high-quality 3D images. (PAAAGHMX100)**Call or Log-on**



BT-3DL2550 3D LCD Video Monitor

The BT-3DL2550 provides everything needed for 3D monitoring in the field. It supports older frame compatible 3D formats and connects easily with common professional interfaces, so it can integrate into any production. The display utilizes an Xpol® polarizing filter that is built in to the screen which brings the 3D content to life. The content can be viewed using polarized (passive) 3D glasses which come included with the monitor. It supports 1080i, 1080p and 720p playback and it offers a pixel to pixel function in the 720p display mode. The monitor also uses two HD/SD-SDI inputs for the simultaneous display of the left and right images and 3D signals. The 3D signals can be supported side by side or line by line through the monitors DVI-D input.

- Offers six different color settings such as: SMPTE, ITU-R BT.709, EBU, Adobe 2.2, Adobe 1.8 and D-Cinema (which offers a 3D look-up table (LUT) for calibration.)
- Includes two HD/SD-SDI inputs, component and RGB, RS-232C (9-pin) and GPI (9-pin) remote inputs. A headphone jack, green and red tally lamps are on the front. Has a time code display, an embedded audio decoder, closed caption and an audio level meter display of up to eight channels.

PABT3DL2550**Call or Log-on**



SONY



HXC-100 HD/SD System Camera

Equipped with Sony's newly-developed digital triax transmission technology, the multi-format HXC-100 allows users to use their facility's existing triax cable infrastructures for a seamless and cost-effective transition to digital transmission and ultimately to HD. The HXC-100 camera supports versatile applications for HD with a high-quality SD output. It uses the latest 14-bit A/D conversion circuit as well as the superb 2/3-inch Power HAD™ FX CCDs to bring out high picture quality. Together with the highly compact 1.5 RU HXCU-100 Camera Control Unit and a remote control panel from Sony, the HXC-100 camera offers a fairly simple system. With a variety of beneficial functions packed into the camera, such as its Focus Assist function, the HXC-100 provides genuine user-friendliness. Features three 2/3-inch Power HAD™ FX CCDs with 2.2 million pixels each, and is switchable between 1080i and 720P 50/60 Hz, with 525i and 625 SD modes available from the camera head and CCU. It offers comprehensive image controls with wide dynamic range and a 14-bit A/D. It also offers a range of automatic features designed to minimize the adjustments necessary during production, including auto iris with multi-zone weighting, auto skin tone detail, auto knee, electronic color correction, focus assist function and hyper gamma.

SOHXC100K..... **Call or Log-on**

HXCU-100

Camera Control Unit for HXC-100

The HXC-100 camera offers flexible configuration with the highly compact 1.5 RU-size HXCU-100 Camera Control Unit, creating a standardized 19-inch rack system that is ideal for space-limited production areas. Combined with the HXCU-100, the HXC-100 can be configured as a simple studio system. Equipped with the latest Sony-developed digital transmission technology, the HXCU-100 can transmit high-resolution pictures between the camera and CCU, regardless of the cable length. The HXCU-100 features flexible interfaces of selectable inputs/outputs between HD-SDI and SD-SDI. What's more, the optional HKCU-FP1 CCU Front Control Panel is also available. When the front panel of the HXCU-100 is replaced with the HKCU-FP1, a simple remote control system can be configured. Many functions of the camera can be controlled by the control knobs and switches on the HKCU-FP1. (SOHXC100K)..... **Call or Log-on**



- Offers a high sensitivity of f/10 for 59.94 Hz and f/11 for 50 Hz with high S/N ratios of -55 dB (HD) and -65 dB (NTSC)
- A wide range of capturing modes are available including 1080/50i, 1080/59.94i, 720/50P, 720/59.94P, 576/50i, and 480/59.94i.
- High-performance 14-bit A/D converter enables images captured by the high-performance CCDs to be processed with maximum precision.
- Auto Lens Aberration Compensation function optimizes lens performance to provide stunning picture quality.
- Offers long cable runs of up to 1200m (3937 feet) via ø14.5 mm cable between the camera and the CCU.
- Provides a wide range of inputs and outputs via the connector panel such as HD-SDI output, SD-SDI output, VF signal, return signal, and SDI Prompter signal. What's more, an intercom channel (ENG/PROD) is also provided.

DSR-45A DVCAM Player/Recorder

The DSR-45 is a compact, comprehensive DVCAM VCR with a variety of convenient functions for recording, playback, and simple editing (assemble only). It features RS-422 and RS-232 (and LANC) machine control, composite, S-video, and component output I/O as well as XLR-balanced audio output. Built-in 2.5" LCD monitor for menu set-up and AV monitoring.

DSR-45 (#SODSR45A)

Sony 3-Year Extended Warranty (#SOEWD)



DSR-1500A DVCAM Player/Recorder

A compact, half rack player/recorder that makes it ideal in production vehicles, desktop editing suites or in any location where space is at a premium. In addition to DVCAM the deck plays back the consumer DV format as well as Panasonic's DVCPRO. Signal outputs include composite video, Y/C, and analog component video standard. Aside from Firewire all the video inputs are optional. Separate supplementary digital input (DSBK-1501) and analog input (DSBK-1504) boards are required.

DSR-1500A (#SODSR1500A)

Sony 3-Year Extended Warranty (#SOEWD)



DSR-1800A Master Series DVCAM Editing VTR

The DSR-1800A DVCAM Master Series digital video cassette deck records 8-bit digital component with a 5:1 compression ratio at a sampling rate of 4:1:1. It offers excellent playback compatibility for all DV family formats 25Mbps cassette sizes, and does not require a cassette adapter or menu setting changes for playback. Playback of Panasonic DVCPRO cassettes. The DSR-1800A offers a variable speed playback function with a range of -0.5 to +0.5 times normal speed. It is equipped with an RS-422A remote control connection to interface with the other compatible equipment. A built-in signal generator for color bars and black burst. 1kHz tone or mute signal for audio. Optional interfaces may be installed for HD up-convert, and SDI/AES/EBU I/O.

DSR-1800A Master Series Digital VTR (#SODSR1800A)

SDI/AES/EBU Input/Output Board (#SODSBK1801)

HD Up-converter Board (#SODSBK1820)

Remote Control Unit (#SODSRM10)

19" Rack-Mount Kit (#SORMM130US)

Sony 3-Year Extended Warranty (#SOEWD)



DSR-DR1000A DVCAM Studio Hard Disk Recorder

The Sony DSR-DR1000A is a DVCAM stream-based, hard-disk recorder that brings new production opportunities. Uses a large capacity hard-disk drive to provide more than twelve hours of DVCAM stream recording.

DSR-DR1000A (#SODSRDR1000A)

Sony 3-Year Extended Warranty (#SOEWD)



DSR-2000A DVCAM Master Series Editing Player/Recorder

The DSR-2000A supports playback of all DV based formats including DVCPRO and DV recorded in both SP and LP. It has pre-read editing for superior frame accuracy, a built-in jog shuttle dial for 2 machine linear editing and Dynamic Motion Control for clear playback and smooth edits at any speed. Also includes Firewire connection for interfacing with non-linear systems.

DSR-2000A (#SODSR2000A)

Sony 3-Year Extended Warranty (#SOEWD10)



SONY

HXR-MC50U

NXCAM AVCHD Camcorder

The optimum HD tool to add to your production arsenal, the HXR-MC50U HD fits comfortably in the palm of your hand, but has HD picture quality to rival that of much bigger cameras. In addition, it can shoot still images as well as video, offers low light capability for nighttime shooting, has an intuitive touch screen viewfinder, a detachable shotgun microphone, and a built-in GPS that keeps track of locations. Just stick it in your vest pocket or stuff it in your camera bag, and you're good to go. Affordably priced, feature-packed and adaptable, this innovative tool is ideal for journalists, documentarians, and government and military operations – or for shooters needing a handy, dependable second camera to get that unobtrusive shot. Designed for performance, built for convenience, and packed with intelligent features, this is the small camera with big capabilities.

- Full raster 1920 x 1080i AVCHD HD recording at up to 24Mbps
- Super sensitive Exmor R CMOS sensor reduces noise for clearer images. In conjunction with the powerful BIONZ processor you'll get great results in low light.
- Sony G 10x wide angle (29.8-298mm equivalent) optical zoom lens delivers brilliant, accurate color reproduction and sharp, amazingly detailed images. The six-bladed iris offers superb shallow depth of field videography.
- Optical SteadyShot Active Mode delivers '3-way' camera shake correction at all zoom settings, even when you're walking.
- Assignable dial allows for control of focus, exposure, white balance, iris, and shutter speed. Adjusting the iris lets you control depth of field, while shutter speed allows control of motion blur.
- Intelligent Auto mode analyzes your shot and then automatically selects the appropriate settings from 10 distinct scene modes.
- Smooth Slow Record mode increases the frame rate from 50 frames per second (fps) to 200 fps, allowing you to capture 3 seconds of fast motion and play the video back in 12 seconds.
- IR illuminator enables effective nighttime imaging under low light conditions. With the NightShot function turned on, images can be recorded in virtually total darkness of 0 lx (lux).

HXR-MC50U: Includes lens hood, ECM-CG1S shotgun mic, NP-FV70 battery, AC Adapter/charger (SOHXRMC50U) **Call or Log-on**

VCL-HGA07B: 0.75x Conversion Lens (SOVCLHGA07B)..... **129.99**

VCL-HG1737C: 1.7x Telephoto Lens (SOVCLHG1737C) **117.95**

HXR-NX5U NXCAM AVCHD Camcorder

The HXR-NX5U incorporates AVCHD technology, three Sony Exmor CMOS sensors with ClearVid array, and state-of-the-art 20x G Lens, to deliver full high-definition resolution and low light sensitivity with low noise. The camcorder will record AVCHD up to 24Mbps, delivering 1920 x 1080 HD images with both interlace and progressive modes along with native 1080/24p, 720/60p and MPEG-2 SD recording. It includes both HD-SDI and HDMI outputs, as well as two-channel linear PCM audio capabilities. It features SMPTE Timecode I/O, built-in GPS function, and an upgrade option for 60i/50i switchable. Utilizing the revolutionary AVCHD format, the HXR-NX5U offers long recording time with dual memory slots - on affordable memory cards. In addition to facilitating a totally IT-based workflow, simultaneous hybrid recording is available in HD/SD formats, using the optional HXR-FMU128 flash memory unit.

- Records Full HD 1920 x 1080 video as well as 720/60p, 60i, 30p and 24p. Offers a choice of bit rates (24/17/9 or 5 Mbps), as well as selectable audio recording – Dolby Digital stereo or LPCM (Linear PCM) stereo which provides uncompressed audio quality.
- Three 1/3" Exmor™ CMOS Sensors improve the color reproduction of video recordings and capture sharp, detailed images even in low-light environments with sensitivity of 1.5 lux.
- 20x zoom "G Lens" zoom 29.5-590mm focal length (35mm equivalent). Two ED glass elements reduce chromatic aberrations.
- Active SteadyShot offers additional stabilization by increasing the optical lens coverage area and by improving detection with state-of-the-art compensation.
- 3.2" (16:9) Xtra Fine LCD with 921,000 dots and 0.45" Xtra Fine electronic viewfinder with 1,227,000 pixels for high-resolution and high-contrast images with remarkable color reproduction.
- Manual zoom, focus and iris for even more flexibility. Offers the same operability as interchangeable lenses.

- Has three built-in neutral density filters, plus manual settings for iris, gain, white balance, shutter speed and focus for increased creativity and control.
 - Equipped with two memory slots for recording to Memory Stick PRO Duo media and SD/SDHC cards, with the HXR-NX5U automatically cycling between the two of them. Using two 32GB memory cards, six hours of continuous HD footage can be recorded.
 - Built-in GPS locator allows satellite data to be recorded directly onto footage for reference. Bundled Content Management Utility software lets you create mapping data and to extract GPS data from video files in latitude/longitude NMEA format.
 - Hardware switch for headphone monitoring lets users change the output to CH-1 or CH-2, or mix both channels together.
 - Outputs HD-SDI, HDMI, component with AV/R, USB and RCA composite and audio. A remote terminal and a TC Link allows two camcorders to be synchronized when they are connected.
- SOHXRNX5U **Call or Log-on**



VCT-PG11RMB 2-Stage Tripod

Features the RM-1BP remote LANC controller on the pan arm for fingertip control of zoom, focus and recording functions, and a 75mm leveling ball-mount for rapid setups. The dual-tubed upper stage provides superior torsional resistance, and the mid-level spreader provides greatly increased vertical strength.

SOVCTPG11RMB **1099.95**



HVL-LBP Battery-Powered LED Light



Ideal for wide-angle shooting, the HVL-LBP features LED reliability and low power consumption, wide uniform light for 16:9 aspect ratios, and operates with daylight-balanced color temperature. Spot or flood lighting with an attached condensing lens. A dimmer dial adjusts the light intensity from 10% to 100%, and an indicator shows the remaining

battery strength even when the light is turned off. Use as a hand-held battery light or on top of a light stand to act as a back-light. Powered by NPF-970 InFoLITHIUM battery for up to 3 hours at maximum brightness. (SOHVLBP)..... **519.95**

VCT-SP1BP Camcorder Support

Weight support for stable/comfortable shooting. Support several shooting styles (eg. high-angle shooting). Quick release function from harness for excellent mobility.



SOVCTSP1BP **714.95**

VCT-SP2BP Camcorder Support

Offers simple but efficient stabilization capable of a variety of shooting styles. Three point support includes shoulder, chest, and operator's hands. Quick release from tripod including tripods which require VCT-U14. Fast and easy transformation from tripod mode to support mode.



SOVCTSP2BP **479.95**

HXR-FMU128 128GB Flash Memory Unit

Designed exclusively for the HXR-NX5U, the optional HXR-FMU128 is a 128GB flash memory unit that enables hybrid recording of video footage. Other capabilities include simultaneous recording of HD and HD video footage, and even the combination of HD and SD, realizing an instant backup in the desired format. The 128GB storage capacity provides continuous recording for up to 11 hours at the highest bit-rate—making it the ideal option for recording music festivals, seminars, and weddings, and for making documentaries, all of which require extended recording times. SOHXRFMU128 **Call or Log-on**



SONY HDV

HVR-A1U CMOS Hand-Held HDV Camcorder

An extremely compact and lightweight camcorder, the The HVR-A1U is equipped with a 1/3" CMOS sensor with 2.97-megapixels and an Enhanced Imaging Processor to deliver outstanding picture quality.

In addition to HDV 1080i recording and playback, the HVR-A1U offers DVCAM/DV recording and playback capabilities, and down-conversion capability of its 1080i recordings for a flexible choice of production systems in HDV, DVCAM, or DV format.

It features a Carl Zeiss Vario-Sonnar T* 10x high-definition zoom lens with four types of zoom control, electronic Super SteadyShot stabilization system, and simultaneous operation of 2.7" LCD monitor and B/W or color 0.44" viewfinder with peaking, histogram and zebra pattern functions. It also incorporates convenient and professional features such as two XLR audio inputs with 48v phantom power, time code capability, automatic shooting modes, and still image recording to Memory Stick Duo media. Other advanced features include Tele Macro function, SuperNight Shot, Skin Tone Detail, Black Stretch and Shot Transition function for smooth automatic scene transitions.

SOHVR/A1U **Call or Log-on**



HVR-Z5U 3-CMOS Handheld HDV Camcorder

A compact HDV camcorder designed to enhance creativity and deliver the highest standard of optical and audio quality, the HVR-Z5U incorporates Sony's 3 ClearVid™ CMOS Sensor system with Exmor™ technology to provide excellent low-light sensitivity and Sony's 20x "G Lens" for superb resolution, color, and contrast, for breathtaking images that rival expensive interchangeable lenses.

This sophisticated lens incorporates Sony's unique optical technology and unparalleled quality control. Moreover, it's been optimized to perfectly complement the camcorder's image sensor and image-processing technology, thus expanding shooting possibilities. The 29.5-590mm (35mm equivalent) wide-angle zoom offers a field of view that's ideal for many shooting situations. Zoom, focus, and iris control rings can be controlled using just one hand. Moreover, the built-in digital extender system increases the zoom ratio to approximately 30x while Sony's optical Super SteadyShot system helps you achieve a stable picture.

SOHVR/Z5U **Call or Log-on**



HVR-HD1000U CMOS Shoulder-Mounted HDV Camcorder



Designed for mobility and professional appearance, the HVR-HD1000U features a shoulder-mount design and black matte body similar to that of professional camcorders. Ideal for corporate communications, colleges, wedding and event videography, the camera is equipped with premium design characteristics, and can record high-definition 1080i on a standard mini DV tape.

A 10x Carl Zeiss Vario-Sonnar lens with SteadyShot image stabilization ensures the perfect shot every time. A built-in down-converter creates DV material, perfect for standard DVD productions. Plus, a special still photo mode is ideal for producing DVD cases and making wedding photo albums.

SOHVR/HD1000U **Call or Log-on**

Sony's HDV Format

The HDV tape transport mechanisms are based on the DV helical scan format. Therefore, videotapes used for DV recording can also be used for HD recording, and the recording time is equivalent. HDV1080i and HDV 720p devices are downward compatible with DV from which both HDV tape transports mechanisms were derived.

The HDV 1080i specification does not follow the DV tape footprint as HDV 720p does. In order to accommodate a higher bit-rate, the HDV 1080i specification adopted a unique track and sector structure that maximizes the length of the track for MPEG-2 payload recording. The video payload bit-rate is 25.4Mbps, which is 28% higher than what is possible by strictly adhering to the DV track and sector structure.

Content originated by HDV 1080i products is routinely used as "contribution" for high end productions, inter-cut with other high definition formats and eventually aired on network broadcasts. The HDV 1080i specification compresses HD video at 25 Mbps (same as DV). The 25Mbps data stream consumes only 2GB for every ten minutes of recording.

HDV 1080i has a very high vertical resolution of 1080 lines. It is possible to deliver 1.85:1 or 2.35:1 film formats with excellent visual quality. The high spatial and temporal resolution of HDV 1080i produces very detailed 35mm film out.

Blu-ray Disc recorders can be connected directly to compatible HDV devices via their i.Link® ports for an efficient and cost effective distribution of high quality prerecorded HD content. One single layer Blu-ray Disc media provides 115 minutes of native HDV 1080i recording. It is not necessary to resort to high compression schemes or to use expensive, time-consuming multi-pass encoders for long form program distribution.

HVR-Z5U • HVR-Z7U • HVR-S270U All Feature

- They incorporate three Sony ClearVid™ 1/3" CMOS sensor chips for high sensitivity, deep resolution, low noise and a wider dynamic range. The sensors capture full HD 1920 x 1080 resolution, resulting in better picture quality when recorded onto mini DV tape in the HDV format (1440 x 1080).
- The 3 ClearVid CMOS Sensor system is enhanced by Exmor technology providing superb performance in low-light environments with sensitivity of 1.5 lux.
- They can switch between HDV 1080i, DVCAM, and standard DV recording for supreme flexibility. Native editing in the HDV format is supported by most popular NLE (nonlinear editing) software.
- They can convert material from 1080i down to 480i and output the video signals through their i.LINK interface and other SD output connectors.
- HDV can also be recorded as a memory file on inexpensive CompactFlash cards using the supplied (optional with the HVR-Z5U) HVR-MRC1K Memory Recording Unit, allowing a streamlined nonlinear editing workflow to be achieved. The cameras have a special shoe connector for direct attachment of the HVR-MRC1K without having to use a cable. The recording unit automatically synchronizes with the cameras, and various recording options (are available when using it in HYBRID operation. Store over two hours of HDV, DVCAM or DV on a 32GB CompactFlash card.
- They feature 24p/30p HDV native progressive recording and 24p/30p progressive scan mode
- They are equipped with Sony's 3.2" XtraFine LCD (921,000 pixels) and 0.45" XtraFine EVF (1.2 million pixels) for high-resolution and high-contrast images with remarkable color reproduction.
- They have three built-in ND filters to help reduce light intensity under bright shooting conditions.
- The HVR-Z5U and HVR-Z7U have HDMI output, the HVR-S270U has an HD/SD-SDI output connector.
- A host of functions enhance operational versatility. These include -6 and -3dB gain settings, Smooth Gain function, advanced histogram, picture profile with up to 6 picture-quality settings, Color Correction and Skin Detail functions, White Balance Shift function and Smooth Slow Rec function which enables smooth slow-motion playback by capturing images 4x faster than normal.

HVR-Z7U • HVR-S270U

3-CMOS Handheld and Shoulder-Mount Interchangeable Lens HDV Camcorders

Ideal for documentaries, electronic newsgathering, independent production, music videos, web streaming, and more, the handheld HVR-Z7U and shoulder-mounted HVR-S270U step up from the HVR-Z5U with a 1/3" bayonet interchangeable lens system. This allows the use of a wide range of lenses from Canon and Fujinon.

Both come standard with a 12x high-quality, multi-purpose Carl Zeiss lens for HD video, with a Vario-Sonnar T* coating to reduce reflections. A specially designed 8x wide-angle lens is also available as an option. These lenses give them the same functionality as Sony's professional fixed-lens camcorders with built-in features such as auto-focus, optical stabilizer, and automatic back-focus adjustment. Using a special adaptor, users can also attach Sony's Alpha series (digital still camera) lenses.

The HVR-Z7U uses InfoLithium batteries and has an HDMI output. The HVR-S270U also supports standard-size cassettes for extended recording times (up to 4.5 hours), has four-channel audio input and has an HD/SD-SDI output connector.

HVR-Z7U (SOHVR/Z7U) **Call or Log-on** HVR-S270U (SOHVR/S270U) **Call or Log-on**



800-947-1175 | 212-444-6675 Quick Dial: 821

SONY HDR-FX1000 3-CMOS HDV Camcorder

With its 24p progressive scan mode, the HDR-FX1000's high-quality film-like motion lets you realize brilliant, broadcast-quality HD imagery. CinemaTone Gamma and CinemaTone Color give your footage an even more film-like feel. Three 1/3" ClearVid CMOS image sensors with Exmor technology capture sharp, detailed images even in low light (to 1.5 lux). The 29.5mm G-Lens with 20x optical zoom allows for wider-angle shooting, while three built-in neutral density filters and three manual rings provide even greater flexibility.



HDV

- 3.2" Xtra Fine LCD display (921k pixels)
 - Smooth slow record (6 seconds)
 - 6 picture profiles
 - 2:3 pull-down to 60i for editing on most HDV software
 - Manual gain/shutter/white balance
- SOHDRFX1000.....**Call or Log-on**

SONY GV-HD700

HDV Portable Video Walkman

A portable player/recorder well suited for ENG and EFP work, the GV-HD700 offers the ability to record SD resolution and playback HDV resolution, view content on its built-in 7" TFT 16:9 LCD screen, or output 1080i/720p signals to an HD display through the HDMI output. Features include x.v.Color Technology, crystal clear still/slow-motion playback, MiniDV SP/LP record/playback, IEEE-1394 (DV) interface, component output, and 12-Bit/16-bit PCM digital audio recording.



- 7" color LCD screen with Active Matrix technology provides clear, accurate colors for on-the-spot playback of recordings.
 - Built in assemble editor lets you mark cut-in and cut-out points for up to 20 separate scenes.
 - Edit images by zooming in up to 2x and cropping (up, down, left, right).
 - Capture digital still images from tape, analog or i.LINK input, directly onto Memory Stick Duo media
 - Analog in/out lets you preserve your analog library by copying it onto a digital format.
- SOGVHD700.....**1049.95**

SONY HDR-FX7

3-CMOS HDV Camcorder

Shoot like a pro with the HDR-FX7 high definition Handycam camcorder. Capture amazing video and still images in high definition with the HDV 1080i 3CMOS sensor, while a Carl Zeiss 20x optical zoom Lens maintains image clarity. Record still images at the same time that you're shooting video. So no matter what the occasion, the HDR-FX7 is the perfect camcorder for the situation.



HDV

- Carl Zeiss 20x HD lens plus a 1.5x digital extender available throughout the entire zoom range
 - 3.5" wide (16:9) Hybrid Clear Photo LCD Plus display
 - Smooth slow record
 - Manual zoom and focus rings
 - Super SteadyShot Optical Stabilization System
 - Picture Profile lets you make adjustments for a scene (color, sharpness, white balance, etc.) into any one of six presets
 - Simultaneously record HD video and 1.2-megapixel still images directly to Memory Stick Duo Media
- SOHDRFX7.....**Call or Log-on**

SONY HDR-V1U

3-CMOS Professional HDV Camcorder

Equipped with a 3-chip ClearVid CMOS sensor combined with Sony's Enhanced Imaging Processor (EIP) technology for higher sensitivity and higher resolution, the HVR-V1U natively captures progressive images at 24p, 30p or 60p, while maintaining full 1080i HDV resolution. It features a Carl Zeiss 10x Vario-Sonnar T* Lens with extra-low dispersion glass, huge 3.5" Clear Photo LCD screen, XLR audio input, time code capability, various automatic shooting modes, and still picture recording. In addition to HDV/1080i, it offers DVCAM/DV recording and playback as well. Down-conversion of 1080i recordings is also provided for a flexible choice of production systems in HDV, DVCAM, or DV format. For added flexibility and versatility, the HVR-V1U enables simultaneous or "hybrid" recording to tape with the optional HVR-DR60 hard-disk recording unit.



HDV

SOHVRV1U.....**Call or Log-on**

SONY HVR-M15AU • HVR-M25AU • HVR-M35AU

HDV Videocassette Recorders

These HDV videocassette decks both offer HDV 1080i, DVCAM, and DV SP recording and playback capability on mini-size DV as well as standard-size cassettes, for easy migration from standard- to high-definition production. They can convert material from 1080i down to 480i and 576i, and output these video signals via its i.LINK, analog component, composite or S-Video connectors.



HVR-M35AU



HVR-M15AU



HVR-M25AU

They can output three types of color bars via i.LINK, HDMI, analog component, S-Video, and composite connectors, as well as a 1kHz audio tone signal via the i.LINK, HDMI, and analog audio connectors.

They copy external timecode through the "HDV/DV in TC" feature and connectivity options include—i.LINK (IEEE-1394), component output, S-Video, composite, and analog audio I/Os. Auto repeat function enables them to automatically rewind the tape to either the beginning of the tape, the first complete blank portion, or an index point on the tape, and start playback again from there. Built-in tape cleaner with high-grade sapphire blade helps prevent signal dropouts and improve the reliability of recording and playback.

- The HVR-M15AU is compact and unobtrusive. Can be placed horizontally or vertically to conform to existing work environments.
- The HVR-M25AU deck adds a 2.7" wide 16:9 ClearPhoto LCD and an HDMI output. DUPLICATE PLUS function makes it easy to copy video and audio from an i.LINK compatible VCR or camcorder. When down-converting signals, the Edge Crop Adjust function is provided to adjust the edge crop position. By displaying the edge crop marker on the LCD monitor, operators can conveniently check the edge crop position before outputting down-converted signals. All Scan Mode—similar to the Underscan mode of ordinary monitors—displays all effective scanning lines in the LCD monitor when 1080i mode is selected. This is useful if you want to check pictures for web applications, for example.
- The HVR-M35AU adds support for "native progressive" recording modes, down-conversion playback, and has HD/SD-SDI output with embedded audio and timecode data, allowing straight duplication to a similarly equipped deck. It can also play back the 4-channel audio data in HDV 1080i format recorded by the HVR-S270U as well as the four-channel audio data in DVCAM format.

HVR-M15AU (SOHVRM15AU).....**Call** HVR-M25AU (SOHVRM25AU).....**Call**
 HVR-M35AU (SOHVRM35AU).....**Call** Sony 3-Year Extended Warranty (SOEWD) ..**Call**

SONY HVR-1500A

Digital HD Video Cassette Recorder

The HVR-1500A is an HDV/DVCAM/DV player and recorder. It offers many must-have professional features such as quick mechanical response, multi-format DV playback, and a robust set of video and audio interfaces ranging from analog to digital SDI and AES/EBU. Additionally, it offers HD-SDI input/output, allowing it to be used as an HD recording deck for cameras with HD-SDI outputs. The HVR-1500A can also be used as a standard definition DVCAM recorder. Designed as a bridge between HDV and HDCAM format, as well as between HDV and XDCAM HD format, use it for dubbing from HDCAM decks for off-line production, such as viewing or distributing content on lower-cost HD media, or for baseband, real-time writing back from an HD non-linear editing system.



- Records in 60i, 50i, HDV 1080i, DVCAM, and DV (SP mode) formats, with DVCPRO 25 playback
- Inputs include SD-SDI, AES/EBU and 6-pin i.Link (HDV).
- Analog video is selectable from HD/SD component, SD composite, S-video, and analog XLR (x2)
- Optional HVBK-1505 Analog Input Board enables analog SD component, composite or S-video, and balanced audio via XLR connectors.
- Optional HVBK-1520 enhances the unit by giving it both up-conversion and cross-conversion capabilities; up-convert DV to either 1080i or 720 or cross-convert 1080i HDV footage to 720p.

HVR-1500A (#SOHVR1500A).....**Call or Log-on**
 HV-BK1505 Analog Input Board (#SOHVBK1505).....**Call or Log-on**
 HVBK-1520 Format Converter Board (#SOHVBK1520).....**Call or Log-on**

SONY XDCAM EX

PMW-EX1R 3CMOS XDCAM EX Pro HD Camcorder

A successor to the award-winning PMW-EX1, the PMW-EX1R adds DVCAM recording, cache recording, picture inversion and a host of additional refinements such as HDMI output, a higher-resolution viewfinder and one-push auto iris. It also features a range of ergonomic enhancements, including an improved hand grip for better balance, smooth handle zoom start/stop, one-click S&Q (Slow & Quick) mode and easy-to-access switches. Incorporating all the benefits of the XDCAM HD optical disc-based recording system – tapeless workflow, selectable bit rates and outstanding picture performance, the PMW-EX1R redefines the standard for a compact professional camcorder. It features three 1/2" Exmor CMOS sensors – each with an effective pixel count of 1920 x 1080, to produce images in full HD resolution. Combining the moderate bit rate of MPEG-2 Long GOP compression with the SxS PRO memory card, the PMW-EX1R offers cost-effective long form recording coupled with non-linear capabilities such as random access and high speed file-based operation. The PMW-EX1R supports multiple frame rate recording such as 59.94i, 50i, and native 23.98P and 25P as well as being 1080i/720P switchable. Equipped with two SxS PRO memory card slots, it can record over four hours of HD footage using two 32GB SxS PRO memory cards. (SOPMWE1R)**Call or Log-on**



PMW-EX3

3CMOS XDCAM EX Pro HD Camcorder with Interchangeable Lenses

Utilizing the same electronics as the PMW-EX1R, the EX3 features an interchangeable 1/2" lens mount, removable viewfinder, and an easy-to-hold body that includes a retractable shoulder pad. It incorporates three 1/2" type "Exmor" Full HD CMOS Sensors, each with 1920 x 1080 effective pixels to deliver stunning-quality HD images in 1080P, 720P and 1080i HD resolutions. Frame rate is selectable from interlace and progressive, such as 59.94i, 50i, 59.94P, 50P, 29.97P, 25P and native 23.98P recording. For creative shooting, it features "Slow & Quick Motion" (over- and-under-cranking), selectable gamma curves, slow-shutter, interval recording and Picture Profile feature. Filmmakers and wildlife/event videographers requiring variable lenses can take advantage of the outside dials for peaking, brightness and contrast, a push-button frame rate dial, and zebra switches for easier viewfinder calibration. Additionally, the PMW-EX3 features genlock and timecode in/out for multi-camera operation. For studio configuration, the RM-B150 or RM-B750 remote controllers adjust camera parameters such as gain, iris, white balance, pedestal, and gamma via the the 8-pin remote connector on the camcorder. (SOPMWE3)**Call or Log-on**



PMW-320 • PMW-350

XDCAM EX Shoulder-Mount Camcorders

Featuring three 1/2" (PMW-320) or three 2/3" (PMW-350) Full-HD CMOS sensors, multiple-format recording, 4-channel audio and solid state SxS workflow, these camcorders set the standard for affordable, high-end videography. They provide an excellent sensitivity (F12 for the PMW-350 and F10 for the PMW-320), remarkable S/N ratio (59dB for the PMW-350 and 54dB for the PMW-320) and high resolution of 1000 TV lines. Whether in HQ 35Mbps HD setting or optional 25Mbps DVCAM recording mode, images are captured quietly and efficiently to SxS PRO or lower-cost SxS-1 memory cards — storing over 4½ hours of MPEG-2 HD video on two 32GB cards. Advanced features include scene file settings, adjustable gamma, and Matrix settings that can be stored on memory cards. They are also studio-configurable, with timecode in/out, genlock in, HD/SD SDI and HDMI out. Compact and well-balanced, they weigh just over 7 lbs., providing a high level of mobility and comfort in many shooting situations. In addition, a low center of gravity, ensures outstanding stability on the shoulder. Miserly users of power, means they can run on a single 90WH battery for up to 5 hours.



PMW-320 with Fujinon 16x Zoom Lens (SOPMW320K)Call or Log-on

PMW-350 with Fujinon 16x Zoom Lens (SOPMW350K)Call or Log-on

PHU-120R

120GB Hard Disk Recorder for XDCAM EX Camcorders

Designed for use with XDCAM EX camcorders, the 120GB drive can be formatted in either one 120GB partition or two 60GB partitions, letting you record up to 400 continuous minutes in HQ (35Mbps) mode or 520 minutes in SP (25Mbps) mode. The ability to record uninterrupted is especially useful for event coverage, sports and documentary-style shooting. The PHU-120R doesn't have—or need—transport controls, record time displays or multiple inputs and outputs. The unit simply plugs into a media slot on the host camcorder or deck, where it is recognized as if it were just another memory card. All read, write and file access operations are controlled by the host recorder. The disk drive itself is suspended inside the PHU-120R chassis by four specially engineered dampers that help protect against shock. (SOPHU120R)**746.95**



MEAD-MS01 Memory Stick Adapter

The same shape as SxS memory cards, the MEAD-MS01 allows you to use Memory Stick media with XDCAM EX camcorders. Since there aren't any protrusions the media cover can be closed during shooting. Memory Stick media recorded with MEAD-MS01 works on a PC without any need for drivers. Folders and files of XDCAM EX are shown in the NLE operation window or in Clip Browser in the same way as with SxS media. (SOMEADMS01)**119.95**



MEAD-SD01 Media Adapter

The MEAD-SD01 media adapter allows the use of SDHC memory cards in XDCAM EX equipment such as the PMW-EX1/EX1R, PMW-EX3, PMW-350 and PMW-EX30. The adapter is recommended for emergency use only. (SOMEADMS01)**110.95**



HVR-MRC1 CompactFlash Recording Unit

The HVR-MRC attaches directly to XDCAM EX camcorders and records up to 144 minutes (on a 32GB card) of HDV ready-to-edit footage. The card records the same .M2T files that are created when capturing HDV footage from tape and provides seamless integration with virtually all non-linear editing systems. Footage can be recorded to both tape and CompactFlash simultaneously, instantly archiving footage while still gaining the workflow efficiency of tape-based media. (SOHVRMRC1)**49.95**



PMW-EX30

XDCAM EX Recording Deck

The PMW-EX30 is a versatile and compact recording deck that can be used for many different applications. It allows simple viewing of recorded materials with a monitor, dubbing to other format/media such as HDV, XDCAM HD and HDCAM, and feeding to nonlinear editing systems. In addition, the PMW-EX30 can be used as an affordable full HD recorder for event recordings — it can record HD signal outputs from a switcher. The PMW-EX30 is equipped with a wide array of interfaces including HD-SDI input and output, HDMI output, HD analog component, composite outputs and more. Equipped with two SxS PRO memory card slots, the PMW-EX30 can record up to 140 minutes of HD footage using two 16GB SxS PRO memory cards. The recording time can be further extended up to approximately 260 minutes when an optional PHU-60K Professional Hard Disk Unit is attached to the deck.



- Highly compact design - can be placed either horizontally or vertically
- MPEG HD recording /playback at 35 and 25 Mb/s
- Equipped with two SxS PRO memory card slots
- Built-in 3.5" LCD monitor
- Adjustable audio input volume (CH1 and CH2)
- HD-SDI input/output, i.LINK (HDV) input/output and component output
- Down-converted SD outputs for migration to SD environments – SD-SDI, i.LINK (DVCAM), component, S-Video and composite
- HDMI output for connection to HDTV displays

(SOPMWE30)**Call or Log-on**

XDCAM HD Versatile, Disc-based Recording System

Sony's XDCAM HD system is suitable for all types of users – including cinematographers, broadcasters, and video professionals – and complements the other products in the Sony range such as the HDCAM Series for high-end video production and the affordable, entry-level HDV Series. One of the major characteristics of the XDCAM HD system is its use of an optical disc as a recording medium. Ideal for broadcasters, production facilities, corporate, government and educational facilities, the tremendous benefits of disc-based operation include instant random access and network capability to name just a few. Sony's XDCAM HD brings these disc-based benefits to HD programming, providing much improved workflows and cost efficiencies as well as offering striking-quality HD images.



#SOPDF335L or #SOPDW355L

SONY PDW-F335L • PDW-F355L

XDCAM HD 1/2" 3CCD Camera with Viewfinder

The PDW-F335L and PDW-F355L are highly versatile and cost-effective HD camcorders. Equipped with three 1/2" HD CCDs they offer HD recording in 1080/59.94i, 50i, 29.97P, 25P, and 23.98P modes – as well as DVCAM-format recording. They incorporate a rich variety of features useful for creative shooting such as interval recording, slow-shutter, and selectable gamma curve. Additionally, the PDW-F355 provides a "Slow & Quick Motion" function, which is also commonly known as "over-cranking" and "under-cranking". They record high-quality uncompressed four-channel audio in HD recording mode. They are also equipped with a range of audio interfaces. They offer highly advanced image control features such as Skin Tone Detail and Dynamic Contrast Control, allowing operators to create stunning images. Picture Cache recording provides up to 12 seconds of loop recording using solid state memory. When in Standby mode and the REC button is pressed, everything that happened up till 12 seconds before that moment can be recorded to disc. Valuable shots, which would otherwise have been missed, are now captured. Disc recording provides users with a number of benefits that are especially useful during shooting. For example, because new footage is always recorded onto an empty area of the disc, there is no need to cue-up to the next recording position before shooting. This means that operators can start shooting without the worry of accidentally recording over existing footage. In short, the XDCAM HD camcorders are ideally suited to a broad array of shooting opportunities such as event shooting, news gathering, field productions, and indie productions.

SONY PDW-700 2/3" XDCAM HD422 Camcorder

The PDW-700 offers striking-quality HD recording at a rate of up to 50MB/s (on 50GB Dual Layer discs) using the MPEG-2 4:2:2P@HL compression, "MPEG HD422. It also provides multi-format recording capability including 1080i, 720p and SD, which comes with HD/SD conversion and cross conversion between 1080i and 720p. The PDW-700 is equipped with three 2/3" CCDs – a "Power HAD FX" progressive CCD with 1920 x 1080 effective pixels. Stunning-quality HD images are captured by this high-resolution CCD in conjunction with the 14-bit A/D converter, 4:2:2 sampling and recording, and advanced digital signal processing. It features two HD/SD-SDI outputs and a composite/HD-Y output, as well as a pool-feed input (HD/SD-SDI and composite) input options. The camera's ruggedness and durability have been enhanced with dust and water resistant mechanisms, as well as features to cool the camera and reduce fan noise. The camcorder maintains XDCAM's file-based architecture and use of proxy video and metadata. It also features a digital extender, picture cache, interval recording, slow shutter, focus magnification, clean switching between the "live and playback" function, and a large 3.5" LCD screen. The PDW-700 has a Live & Play function that can simultaneously output both playback signals (images already recorded) and incoming camera signals (images seen through the viewfinder). Both signals are fed to their respective output and viewfinder connectors independently, and can be viewed at the same time. This allows users to frame the next shot, adjust the exposure, and even focus the lens while the camcorder is playing back recordings from the disc. With fast file-based operations and superb picture quality, the PDW-700 is an invaluable tool for news gathering, TV, documentaries, and entertainment programming where a high-quality look is everything.



#SOPDW700

SONY PDW-F800 2/3" XDCAM HD422 Camcorder

The PDW-F800 CineAlta® camcorder offers a frame rate of 23.98P natively in 1080 mode and multi-format recording flexibility as standard – including standard-definition recording to support legacy formats (MPEG IMX®, DVCAM™ and 4:2:0 HD content). It also provides multi-format (1080i/720P) recording, as well as HD/SD conversion and cross-conversion during playback between 1080i and 720P. Record HD content (95 minutes at 50 Mbps) to the dual-layer PFD50DLA 50GB optical disc. The PDW-F800 adds variable frame rate recording for slow and quick motion capabilities, also known as "over-cranking" and "under-cranking." The camcorder uses three of Sony's new 2/3-inch Power HAD™ FX progressive CCDs that can produce a resolution of 1920 x 1080, delivering high quality, four-channel 24-bit audio recording. An image inverter feature enables the camera to be used with cinema lens adaptors, and a variety of gamma settings includes HyperGamma and user-selectable gamma curves. A focus assist bar-graph display is visible on the camera's viewfinder, and users can record proxy data to USB removable media to make transferring data easier and faster, especially in the field or on location between the camera and a PC or editing system.

Also features auto tracing white balance hold, output markers such as safety, aspect, and center on the HD-SDI output, slow shutter, interval recording, picture cache recording (up to 30 seconds), disc exchange cache and "shock-less" gain control. Option boards are

available to enable pool-feed operation. The camcorder features a 2x digital extender to enhance zoom capabilities, enabling images to be doubled in size without any loss of image sensitivity. It also has slow shutter, 2x focus magnification, clean switching between the "live and playback" function, and a large, easy-to-view 3.5" color LCD screen. (SOPDF800)

PDW-1500 XDCAM Compact Deck

A half-rack XDCAM recorder for Sony's line of non-linear optical cameras. Features include high speed file transfer, Metadata recording and multiple format capability. Thumbnail search operation means no more winding through endless amount of recorded tape; each shot is right at your fingertips.

PDW-1500 (SOPDW1500).....**Call or Log-on**
Rackmount Kit (SORMMDSR15).....**Call or Log-on**
Hard Shell Carrying Case (SOLCPDW15H).....**Call or Log-on**
Remote Edit Controller (SORM280).....**Call or Log-on**

**PDW-F75** XDCAM HD Decks

Increase your workload efficiency and flexibility. Supports 1080/59.94i, 50i, 29.97P, 25P and native 23.98P, with DV CAM playback. Features up and down HD signal conversion, precise variable jog/shuttle, and a 3.5" color (16:9) LCD screen.

• Accepts the dual layer 50GB XDCAM HD discs • Records with MPEG HD codec at 35, 25, and 18 Mb/s via HD-SDI input/output and AES/EBU audio

PDW-F75 (SOPDF75).....**Call** **Plug-in Board** (SOPDBK101).....**Call**
HDV I/O Board (SOPDBK102).....**Call** **RGB/HD Component Input Board** (SOPDBK103).....**Call**
Up-Conversion Board, SD-SDI, Analog, Composite (SOPDBK104).....**Call**
Remote Edit Controller (SORM280).....**Call**
Rackmount Kit (SORMMF7030).....**Call** **IEEE1394 Interface Board** (SOLCPDW70).....**Call**

PDW-V1 Mobile XDCAM Player with LCD

Built upon blue-laser technology, XDCAM products increase non-linear workflows while maintaining the same archiving infrastructure of traditional tape-based acquisition schemes

• Capable of playing back both MPEG IMX and DV CAM without the need of an external device

SOPDWV1.....**Call or Log-on**



ThermoDyne SlimLine hard transit case (SOLCPDWR1).....**Call** **Li-Ion V-mount battery 65Wh** (SOBPL65).....**Call**
Li-Ion V-mount battery 83.5Wh (SOBPL80S).....**Call** **2-position battery charger** (SOBCL70).....**Call**

PDW-U1 XDCAM Drive Unit

The PDW-U1 drive unit is designed specifically for XDCAM cameras. It will act as a conduit between the camera and your NLE.

- Handles SD and HD professional disc media using Sony's patented blue-violet laser, as well as the PFD50DLA dual-layer disc
- Cost-effective, lightning-fast transfers streamlines post-production workflow
- XDCAM HD dual discs are compatible with the PFD50DLA, along with the standard professional disc blue-laser media

SOPDWU1.....**Call or Log-on**

PDW-F1600 XDCAM HD Player/Recorder

The Sony PDW-F1600 is an XDCAM HD422 recorder and player. Built upon blue laser technology, the XDCAM HD line of products takes advantage of non-linear workflow, while keeping the same archiving infrastructure professionals are accustomed to with tape-based formats. The player is ideal for transferring footage into non-linear workstations.

SOPDFW1600.....**Call or Log-on**

**PDW-HR1**

XDCAM HD422 Field Recorder

The Sony PDW-HR1 is a portable recorder for Sony's high-end XDCAM HD422 format. The recorder accepts both dual and single-layer professional discs and can record in a variety of different settings. The unit features a 9" LCD viewer, built-in stereo speaker, and can be powered using IDX batteries, making it ideal for field recording.

SOPDWHR1.....**Call or Log-on**

PDW-HD1500

DCAM HD Compact Deck

The Sony PDW-HD1500 is a half rack XDCAM HD recorder for Sony's line of optical disc-based cameras, including the PDW-700. Built upon blue laser technology, the XDCAM HD line of products takes advantage of non-linear workflow, while keeping the same tape-based archiving infrastructure that professionals are accustomed to.

SOPDWH1500.....**Call or Log-on**

**Compact Prime CP.2 Lenses**

Compact Prime CP.2 lenses are the latest members of the Zeiss family of lenses for digital and film cameras. This second generation delivers even greater flexibility by offering interchangeable mounts that allow the lenses to be used with a wide range of



cameras from traditional cine to HDSLR systems. They also offer a wide choice of lenses – from wide-angle to tele (18 to 100mm, including a 50 mm macro lens). With precision and speed – Compact Prime CP.2 lenses are the perfect tool for Independent filmmakers, professional still photographers expanding their services or large studios using HDSLR equipment as a second camera unit for TV and film productions.

- Compact Prime CP.2 lenses offer professional quality on a budget and have been designed for both film cameras and the next generation of digital motion picture cameras. Covering the Super 35 as well as the full-frame still format, makes these lenses a safe investment for the future.
- Allows a mix of HDSLR systems with traditional cine cameras, for maximum flexibility on set
- No need for adapter solutions anymore
- Three different mounts available (PL, EF and F mount)
- Changing the lenses is fast and easy and offers great flexibility, regardless of the camera equipment used.
- Cover a full-frame image format without vignetting. Combined with the interchangeable mount, the Compact Prime CP.2 offers the possibility to upgrade to any number of existing or future cine and still cameras while still utilizing the same set of lenses.
 - Full-frame coverage (24 x 36mm) for focal lengths 21-100mm
 - Common aperture of T2.1 for the standard lens set
 - Sweet spot effect with APS-C sensors
- The iris opening is created by 14 high precision blades. It stays consistently round and symmetrical over the entire T-stop range. This translates into natural and pleasing out-of-focus highlights and a smooth bokeh. Together they help create and capture special moments on film.
- The modern lens design as well as the cine manufacturing process and tight tolerances ensure low distortion, high resolution and excellent color rendition for sharp, punchy images.
- Improved functionality of Compact Prime CP.2 lenses means better ergonomics compared to standard SLR lenses:
 - Standard housing dimensions
 - Standard focus and iris gear positions
 - Consistent front diameter
 - Robust construction
 - Longer focus rotation and a manual focus
 - Stable exposure due to manual operated aperture

18mm/T3.6 Cine Lens (EF Mount) (ZECPT3618EF).....**3900.00**

21mm/T2.9 Cine Lens (EF Mount) (ZECPT2921EF).....**3900.00**

25mm/T2.9 Cine Lens (EF Mount) (ZECPT2925EF).....**3900.00**

28mm/T2.1 Cine Lens (EF Mount) (ZECPT2128EF).....**3900.00**

35mm/T2.1 Cine Lens (EF Mount) (ZECPT2135EF).....**3900.00**

50mm/T2.1 Cine Lens (EF Mount) (ZECPT2150EF).....**3900.00**

85mm/T2.1 Cine Lens (EF Mount) (ZECPT2185EF).....**3900.00**

PRO LENSES



Fujinon HDTV (XDCAM) HD 1/2" Mounted Lenses

- XS13x33BRMM** 13:1 (3.3–43mm) Servo Zoom
- XS13x3.3RM-M** 13:1 (3.3–43mm) Servo Zoom w/Dual Hot Shoe
- HS16x46ERM** 16:1 (4.6–74mm) w/2x Extender
- HS16x4.6ERM-M** 16:1 (4.6–74mm) Servo Zoom w/2x Extender
- XS17x55BRMM** 17:1 (5.5–94mm) Servo Zoom
- XS17x5.5RM-M** 17:1 (5.5–94mm) Servo Zoom w/Dual Hot Shoe
- HSS18x55BRDS** 18:1 (5.5–100mm) Servo Focus
- HS18x55BERM** 18:1 (5.5–100mm) Servo Zoom w/2x Extender
- HSS18x5.5BMD-D18** 18:1 (5.5–100mm) Motor Focus with Remote Control
- HSS18x5.5RM-M** 18:1 (5.5–100mm) Servo Zoom w/Dbl Hot Shoe
- HSS18x5.5RD-S** 18:1 (5.5–100mm) Servo Foc/Zm w/Dbl Hot Shoe
- HSS18x55BRM** 18:1 (5.5–100mm)
- HSS18x5.5ERM-M** 18:1 (5.5–100mm) w/2x Extender
- HSS18x5.5ERD-D** 18:1 (5.5–100mm) Servo Focus w/2x Extender

Canon HDTV (XDCAM) HD 1/2" Mounted Lenses

- KH10ex3.6-IRSE** 10:1 (3.6–36mm) Servo Zoom w/ 2x Extender
- KH13x4.5-KRS** 13:1 (4.5–59mm) Servo Zoom
- KH16x5.7-IRSE** 13:1 (5.7–92mm) Servo Zoom w/2x Extender
- KH19x6.7-KAS** 19:1 (6.7–127mm) Servo Zoom, Auto Focus
- KH19x6.7-KTS** 19:1 (6.7–127mm) w/Rem Cntrl & Shuttle Shot
- KH20x6.4-KRS** 20:1 (6.4–128mm) Servo Zoom
- KH21ex5.7-IRSE** 20:1 (5.7–120mm) Servo Zoom w/2x Extender
- MS-15M** Zoom and Focus Control Kit for ENG/EFP Lenses

Fujinon HDTV HD 2/3" Mounted Lenses

- HA13x4.5BRD** 13:1 (4.5–59mm) Servo Focus/Zoom
- HA16x6.3ERM-M** 16:1 (6.3–101mm) Servo Zoom w/2x Extender
- HA16x6.3ERD-S** 16:1 (6.3–101mm) Servo Focus/Zoom w/2x Ext
- HA18x7.6ERM-M** 18:1 (7.6–137mm) Servo Zoom w/2x Extender
- HA18x7.6ERD-S** 18:1 (7.6–137mm) Servo Focus/Zoom w/2x Ext
- HAC18x7.6B** 18:1 Compact Cinema Zoom (7.6–137mm)
- HA22x7.8ERM-M** 22:1 (7.8–172mm) Servo Zoom w/2x Extender
- HA22x7.3ERD-S** 22:1 (7.3–161mm) Servo Focus/Zoom w/2x Ext
- HA25x11.5ERD-S** 25:1 (11.5–288mm) Servo Foc/Zoom w/2x Ext
- HA25x16.5ERD-F18** 25:1 (16.5–413mm) Servo Focus/Zoom w/2x Motor Driven Extender

Canon HDTV HD 2/3" Mounted Lenses

- HJ11ex4.7B-IRSE** 11:1 (4.7–52mm) Servo Zoom w/2x Extender
- KJ16ex7.7B-KRSD** 16:1 (7.7–124mm) Servo Zoom
- KJ16ex7.7B-IRSD** 16:1 (7.7–124mm) Servo Zoom w/2x Extender
- HJ17ex7.6B-IRSE** 17:1 (7.6–130mm) Servo Zoom w/2x Extender
- KJ20x8.5-KRS** 20:1 (8.5–170mm) Servo Zoom
- KH21x57IRS** 21:1 (7.6–160mm) w/2x Extender

Canon HD 2/3" Prime Lenses

- FJS5MM T1.7** 5mm T/1.7 Prime Lens
- FJS9MM T1.5** 9mm T/1.5 Prime Lens
- FJS14MM T1.5** 14mm T/1.5 Prime Lens
- FJS24MM T1.5** 24mm T/1.5 Prime Lens

Canon HD 2/3" Crossover Lenses for 16:9 / 4:3 Cameras

- J11ex4.5B-VASE** 11:1 Lens (4.5–50mm) Servo Focus/Zoom
- J17ex7.7B-VASE** 17:1 Lens (7.7–131mm) Servo Focus/Zoom
- J22ex7.6B-VASE** 22:1 Lens (7.6–168mm) Servo Focus/Zoom

Fujinon Lens Zoom / Focus Controllers

- MS-11** Rear lens controller kit
- MS-21D** Digital rear lens controller (lenses w/ratio converters)
- MS-15M** Canon digital rear lens controller kit
- MS-22M** Canon rear lens controller kit

Sony Lens Zoom / Focus Controller

- MS-01** Rear zoom and focus control kit (Fujinon lenses)

Manfrotto Lens Zoom / Focus Controllers

- 524CFI** Pan bar-mounted remote control (Canon/Fujinon)
- 524CN** Zoom remote controller (8-pin Canon lenses)
- 524AX** Zoom remote controller (8-pin Angenieux lenses)

Varizoom Lens Zoom / Focus Controllers

- VZ-JZFF** Focus/zoom remote controller (Fujinon lenses)
- VZ-SPGF12** Focus/zoom rem. control kit (Fujinon 12-pin lenses)
- VZ-SPG-F** Focus/zoom remote control kit (Fujinon lenses)
- VZ-SPRO-F2** Focus/zoom rem. control kit (Fujinon 1/2" lenses)
- VZ-SPRO-C** Focus/zoom remote control kit (Canon lenses)
- VZ-SPRO-F** Focus/zoom remote control kit (Fujinon lenses)

SRW-9000 2/3-inch HDCAM-SR Camcorder

The SRW-9000 is a one-piece, modular 24P camcorder platform that redefines "future proof." Designed as a next-generation younger sibling to Sony's renowned CineAlta F35 digital cinema camera, the SRW-9000 manages to introduce new technology while trimming costs and adding unprecedented levels of flexibility. The world's first shoulder-mounted HDCAM-SR camera, the SRW-9000 uses the F23's chipset and the lossless capture afforded by the MPEG4-SSIP (Simple Studio Profile) recording format, to create professional-grade 1080p images with customizable gammas and up to 12 stops of dynamic range for true film-like images. This makes the SRW-9000 the perfect tool for features, commercials, documentaries or music videos – either as a low-budget 'A' camera or as a 'B' or Steadicam camera on larger productions.

But the SRW-9000 isn't just a camera, it's a system. Sony's first truly open-platform product, it can be tailored to the specific needs of each production. As with previous CineAlta camcorders, its B4 lens mount allows for the full range of professional 2/3" HD lenses. But the SRW-9000 goes even further. Need to shoot in 4:4:4 color? Or with incremental, variable frame rates? Optional processing boards let you go there.

Even more revolutionary, the SRW-9000 can switch out its 2/3" sensor for a 35mm sensor and 35mm PL mount – allowing the highest image quality possible. Add the 1TB SR Memory Pack, and the camera will be able to switch from standard HDCAM-SR tape recording to solid state capture. Offering an unprecedented 5Gbps data rate and Raid-5 security, the Memory Pack allows shooting in 3D, 4K, and 8 different HD streams, at the same time improving post-production workflow by recording color information in the video stream's metadata to provide a built-in color management system.

- Providing improved operational flexibility and cost benefits, the SRW-9000 is the perfect choice for anyone in the broadcasting industry seeking HDCAM-SR picture quality and a high level of creative freedom. Used for stunning visual productions in digital cinema, commercial programs, TV dramas, and documentaries.
- In standard confuration, the SRW-9000 is capable of top-quality 4:2:2 Y/Cb/Cr 10-bit recording at 1080/23.98p, 24p, 25p and 29.97p, and at 1080/50i and 59.94i. In addition, the SRW-9000 can record 1080/50p and 59.94p signals, and 4:2:2 720/50p and 59.94p* signals, making it ideal for DTV programming and transmission applications. For users who require further creative performance, a variety of option cards can be added, allowing the benefits of full-bandwidth 1080 RGB 4:4:4 capturing, SR Motion™ variable frame rate capturing and recording, S-Log Gamma, and additional signal inputs and outputs.



- Sony's BP-GL Series of on-board batteries can be attached to further extend shooting times.
- State-of-the-art 2/3" sensor can be upgraded with the same Super 35mm sensor used in Sony's F35, while the internal HDCAM SR tape deck can be swapped out for a revolutionary solid state unit.
- Accepts three types of viewfinder, including the HDVF-20A/200, HDVF-C35W, and HDVF-C30WR. The HDVF-C30WR offers improved focus assist functions, a color brightness level indicator, and numerous other beneficial features. Moreover, with pre-installed viewing LUTs for S-Log Gamma, this viewfinder provides users with easier focus adjustment and a more intuitive photo-shooting operation.
- Versatile gamma settings include the unique S-LOG Gamma (HKSR-9003), HyperGamma, and customizable gamma curve (standard).
- With Picture Cache Re-recording capability, everything captured up three seconds before the REC button is pressed is recorded to HDCAM SR tape when the camcorder is in stand-by mode.



HDW-S280

HDCAM Half-Rack Field Recorder

The HDCAM recorder is ideal for field and mobile playback. The CineAlta brand has become synonymous with high quality film and TV digital acquisition.

- Features a small, lightweight frame
- Betacam SX/SP tape playback
- Built-in down-conversion and up-conversion
- Front panel LCD • HD-SDI in/out
- Runs on AC, DC 12V, and battery power
- Records at 24P, interlaced or progressive, 1080/59.94i, 50i, 23.98PsF, 24PsF, 25PsF and 29.97PsF
- Dimensions: 8.375 x 5.25 x 16.75"
- Weighs 13.3 lb



- | | | | |
|------------|--------------------------|-------------|-------------------------------|
| #SOHDWS280 | | #SOHKDW102 | SDTI interface board |
| #SORM280 | Remote edit controller | #SOBKMW102 | Desktop control panel holder |
| #SORMM131A | Rack mount kit | #SOBKMW103 | Control panel remote ext. kit |
| #SOHKDV900 | Digital video controller | #SOMLB1M100 | 100 tele file memory labels |
| #SOHKDW101 | Control panel | | |

HDWM2000/20 Series

HDCAM Video Cassette Recorder/Player with Legacy Playback

The HDW-2000 Series bridges the gap between HD and SD. These powerful workhorse solutions offer full HDCAM record and editing abilities, and legacy playback of BETACAM/BETACAM SP, Digital BETACAM, BETACAM SX, and MPEG IMX 1/2-inch tape recordings.



- Can record HDCAM at variable frame rates
- Built-in down-conversion
- Down-convert 1080 HD signals on the fly
- Frame accurate recording without preroll
- They measure 16.8 x 9.3 x 20.5" (WxHxD) and weighs 50 lbs. each

- | | |
|---------------|--|
| #SOHDWM200020 | HD rec. / HD and Legacy playback |
| #SOHDWM210020 | HDCAM and Legacy playback |
| #SOHDW200020 | HDCAM record and playback |
| #SOHDWD200020 | HD record / Digi Beta, MPEG IMX playback |
| #SOHDWS200020 | HD record / HD, Legacy playback |

HDW-1800 / HDWD-1800



HDCAM Studio Editing Recorder

The CineAlta HDCAM studio editing recorder features a wide variety of advanced options, making the adoption of and integration of professional-grade high definition acquisition a more seamless transition than ever before.



- Record and playback HDCAM 1080/59.94i, 50i, 25PsF, 29.97PsF, 23.98PsF, and 24PsF formats
- Built-in down-converter enables output at 480/59.94i or 576/50i • Color LCD monitor
- HDW-D1800 adds SD to HD playback/mastering for Digi Betacam and MPEG IMX

- | | | | |
|----------|------------|-------------------------------|-------------|
| HDW-1800 | #SOHDW1800 | HDWD-1800 | #SOHDWD1800 |
| | #SOHKDW104 | 3:2 pd, 720p conversion board | |
| | #SOHKDW105 | i.Link/HDV input board | |
| | #SOHKDV900 | Digital video controller | |
| | #SORMM131A | Rack mount kit | |

SRW-5100/2 • SRW-5800/2

HDCAM SR Studio Player and HDCAM SR Studio Recorder

The SRW-5100/2 and SRW-5800/2 support 2K recording and playback at both 2048 x 1080 and 2048 x 1556 modes, MXF file transfer of the SStP codec and the "SR-Lite" 220 Mbps data rate, and 96KHz audio. They also support double speed record and playback, as well as 3D content record and playback of 4:2:2 & 4:4:4 RGB.



The SRW-5100/2 is a top-quality player for viewing, screening, dubbing, and ingestion. It plays HDCAM-SR recordings in 1080 50/60i, 1080 24/25/30PsF and 720 50/60P. Format conversions such as 1080i from/to 720P and 2-3 pull down are available with the optional HKSR-5001. Plays 880Mbps mode, such as 4:4:4 HQ, 1080 50/60P and dual stream materials (3D) with optional HKSR-5103 board. HDCAM and Digital Betacam tapes can be played back with optional HKSR-5802 board. Create HDV editorial copy of HDCAM-SR and HDCAM format materials with the optional HKSR-5105 board.

The SRW-5800/2 records 1920 x 1080 10-bit HD signals using MPEG-4 Studio Profile with virtually loss-less compression. 12 channels of 24-bit discrete uncompressed audio can also be recorded.

- | | |
|---------------------------------------|-----------------------|
| SRW-5100/2 (#SOSRW51002) | Call or Log-on |
| SRW-5800/2 (#SOSRW58002) | Call or Log-on |

SRW-5000/2 • SRW-5500/2 HDCAM SR VTR's

The SRW-5000/2 and SRW-5500/2 are designed to be used in conjunction with Sony's top-quality CineAlta line of cameras, to deliver the pinnacle in HD acquisition. Providing the highest quality solutions for the most demanding cinematographers, the HDCAM SR format records full bandwidth video at nearly 3.5x the data-rate of HDCAM, providing the highest quality image available. This virtually loss-less image acquisition represents video comparable to that of film. Otherwise the same, the SRW-5000/2 is exclusive for HDCAM-SR recording, while the SRW-5500/2 adds HDCAM recording as well.



They can record in the 4:2:2 format and be combined with current HDC series studio cameras to form a system that is ideal for high-end studio/OB production applications. Or they can be combined with the HDC-F950, to form a full-bandwidth 4:4:4 (RGB) image capturing-system. They support multi-frame-rate recording on the HDCAM SR format, and feature integrated up-conversion, down-conversion, 2-3 pull-down, and legacy playback of HDCAM and Digital Betacam tapes. For digital content mastering applications and for future content delivery methods, they come with 12 channels of digital sound.

- | | |
|--------------------------------------|-----------------------|
| SRW-5000/2 (SOSRW50002) | Call or Log-on |
| SRW-5500/2 (SOSRW55002) | Call or Log-on |

DVW-2000 / DVW-M2000

Digital Betacam VTR's

The DVW-2000 Series of Digital Betacam VTR's continue to offer top-quality SD recording and archiving, while paving the way for future HD operations



DVW-2000

- DVW-M2000 step-up features include playback capability for all Sony 1/2 inch standard-definition legacy format tapes—Betacam, Betacam SP, Betacam SX, MPEG IMX and Digital Betacam
- Plug-in HD upconversion option allows HD signal output of 1080/59.94i or 720/59.94P
- Metadata handling capability, flexible audio operation, and compact body design
- Editing features—frame-accurate insert/assemble editing, pre-read editing capability, digital audio jog sound, variable speed playback



DVW-M2000

- | | | | |
|------------|---|-------------|--|
| DVW-2000 | Digital betacam VTR | #SODVW2000 | |
| DVW-M2000 | Digital betacam Studio VTR / Legacy 1/2" playback | #SODVWM2000 | |
| #SOBKMW104 | Upconverter board | | |

Ikegami

HLM-920WP • HLM-1510R • HLM-1750W • HLM-2450W

The HLM-920WP (9") and HLM-1510R (15") are LCD monitors designed to save space and consume low amounts of power. This makes them ideal for OB vans and outside broadcasting. Features include an on-panel protective overlay, HD-SDI, tally, as well as both VESA and rack mounting compatibility. They also offer built-in 3 remote types, 10 color-temperature memory presets, waveform monitoring, marker, and a test signal generator. For audio they have full XLR analog audio input capability and built-in speaker for easy sound monitoring. Additionally the HLM-920WP is equipped with an Anton Bauer Gold battery mount and has the ability to convert to a V-mount system, making it ideal for field work. Otherwise the same, the HLM-1750W (17-inch) and HLM-2450W (24-inch) are designed specifically for professional editing workstations and broadcast studios.



- HLM-920WP:** 9" Multi-Format LCD Monitor (IKHLM920WP).....**Call or Log-on**
- HLM-1510R:** 15" Multi-Format LCD Monitor (IKHLM1510R).....**Call or Log-on**
- HLM-1750W:** 17" Multi-Format LCD Monitor (IKHLM1750W).....**Call or Log-on**
- HLM-2450W:** 24" Multi-Format LCD Monitor (IKHLM2450W).....**Call or Log-on**

JVC DTV-17G1Z • DTV-24G1Z

17- and 24-inch Verité 3G HD-SDI/SDI Studio Monitors

The 17-inch DT-V17G1Z and 24-inch DT-V24G1Z set the standard for picture quality. They are 3G/Dual-Link ready for monitoring of 60 frames/3GB per second uncompressed 1080p digital video input signals. They feature 10-Bit 4:4:4 video processing for superior image gradation and have built-in high quality vectorscope and ultra high resolution waveform monitor with adjustable over-level indicator function. There is a 12-channel embedded audio metering display with peak hold viewable above or below active picture area. They also offer computer automated calibration capability of black and white levels, color temperature and gamma for mission-critical monitor matching.



Connections include:

- HD/SD SDI (x2 In, x1 switched out), component/RGB and composite video input/output
- DVI-D (HDCP Video and PC) Input • Audio inputs with built-in speakers
- ASCII Code Input for Source ID
- RS-232C, RS-485 (RJ-45 In and Out) and Make/Trigger (RJ-45 In) external control connections

- DT-V17G1Z:** Verite 17" 3G HD-SDI/SDI Studio Monitor (JVDTV17G1Z).....**Call or Log-on**
- DT-V24G1Z:** Verite 24" 3G HD-SDI/SDI Studio Monitor (JVDTV24G1Z).....**Call or Log-on**

Panasonic BT-LH1710 • BT-LH1760 • BT-LH2550

Widescreen HD/SD LCD Video Monitors

The versatile AC/DC powered BT-LH1710 provides production-tough, HD broadcast-quality performance for a wide range of applications—in the studio or in the field. 10-bit image processing engine has a 3D look-up table (LUT) that calibrates it to reproduce accurate images according to the specific color standard selected. It features built-in waveform monitor and vectorscope, embedded audio support, pixel-to-pixel display, cross hatch overlay, audio level meters, time code and closed caption displays. Equipped with two HD-SDI/SDI auto-switching inputs with a switched output, and a DVI-D input for connection to digital devices with a DVI-D output. Otherwise the same, the BT-LH1760 has a 120Hz double-speed drive, twice that of the BT-LH1710 to handle fast motion content exceptionally well and reduce image blur to a level never before seen in a professional LCD display. With full 1920 x 1200 HD resolution, the 25.5" BT-LH2550 LCD production monitor delivers stunning picture quality and greatly expands the range of colors you can view on screen. Designed for applications that require the highest resolution and color performance, it surpasses the ITU-R BT.709 standard (130%), enabling it to display a greater range of colors than conventional LCD and CRT displays.



- BT-LH1710:** 17" Widescreen HD/SD LCD Video Monitor (PABTLH1710).....**Call or Log-on**
- BT-LH1760:** 17" Widescreen HD/SD LCD Video Monitor (PABTLH1760).....**Call or Log-on**
- BT-LH2550:** 25.5" Widescreen HD/SD LCD Video Monitor (PABTLH2550W).....**Call or Log-on**

SONY LMD-1530

15-inch WXGA HD Monitor with HDMI

Ideal for HDV monitoring, the LMD-1530W incorporates a 15:9 aspect ratio and WXGA (1280 x 768) LCD panel. It offers HD input via HDMI and analog component interface. It also offers a full range of analog SD inputs including composite (NTSC/PAL), S-Video and component and RGB. SD-SDI input can be achieved with the optional BKM-320D adapter. It can display various area markers, including a center marker and aspect markers with selectable brightness. It also offers selectable color temperatures and gamma modes and 3-color tally lamp. SOLMD1530W.....**Call or Log-on**



SONY High-Grade LUMA SERIES

17-, 20- and 24-inch Professional HD Monitors

Designed for broadcast and multimedia applications where performance and reliability are critical, Sony's high-grade type LUMA monitors incorporate the latest DSP engine, ChromaTRU color-matching technology, and high functionality. They accept a variety of signals in both digital and analog, and HD and SD formats. The LMD-2451W also offers 3G SDI input capability.



- Standard interfaces include composite (NTSC/ PAL), S-Video, 525i/625i component and RGB. Optional digital interfaces including HD-SDI and SD-SDI are also available.
- With HD-15 and DVI-D interfaces and built-in high-performance scan converters, they can display PC signals from VGA to WUXGA as well.
- They can display various area markers, including a center marker, aspect markers, and a safety zone marker. The brightness of these markers can be selected from three different levels: white, gray, and dark gray. Black or gray matte can also be used to fill the outer area of the aspect markers.
- Selectable color temperatures (9300K, 6500K, or a user preset value)
- Selectable scan size (5% over scan and 0% scan modes and aspect ratio (16:9 and 4:3)
- Equipped with three-color tally lamp that can be lit via a parallel remote connector.
- They can be controlled remotely via a parallel and serial remote connector.

- LMD-1751W:** 17" High Grade Multi-Format LCD Monitor (SOLMD1751W).....**Call or Log-on**
- LMD-1751W** with BKM-243HS HD-SDI Board (SOLMD1751WHD).....**Call or Log-on**
- LMD-2050W:** 20" High Grade Multi-Format LCD Monitor (SOLMD2050W).....**Call or Log-on**
- LMD-2050W** with BKM-243HS HD-SDI Board (SOLMD2050WHD).....**Call or Log-on**
- LMD-2451W:** 24" High Grade Multi-Format LCD Monitor (SOLMD2451W).....**Call or Log-on**
- LMD-2451W** with BKM-243HS HD-SDI Board (SOLMD2451WHD).....**Call or Log-on**

SONY BVM-A14F5U / A20F1U

Multiformat CRT Broadcast Monitors

Master-grade CRT monitors with SMPTE-C phosphors. Configurable modular slot design supports multi-format inputs. Top-quality images up to 1080/50i and 1080/60i 4:4:4 RGB. Test signal generator, H/V delay, sync signals, degaussing and various area markers for support of DTV and cinema aspect ratios.

- BVM-A14F5U** 4:3 aspect - 14" (13 1/8" viewable) (SOBVM14F5U) SDI/Analog composite multi-input adapter (SOBKM61D) Analog component input adapter (SOBKM68X)
- BVM-A20F1U** 4:3 aspect - 20" (19" viewable) (SOBVM20F1U) HDS/SDI input board option (SOBKM62HS)



SONY BVM-L230

23" Trimaster Professional Master LCD Monitor

A professional monitor built specifically for high-end finishing studios. Features a 12-bit output and 10-bit driver. Input slots for optional SDI, HD-SDI, RGB, Component, or Y/C.

- DVI-D input
- #SOBVML230 #SOBKM220D SDI input board
- #SOBKM16R Control unit
- #SOBKM243HS HDSDI 4:2:2 SDI input adapter
- #SOBKM227W Input adapter for LMD2140
- #SOBKM229X Component input adapter for LMD2140
- #SMF700 Remote interface cable
- #SOBKM37H Controller attachment stand





ELIPZ 10K Battery
Lithium-Ion Under-Camera
Battery System

The ElipZ 10K 75Wh battery is an excellent high-capacity power source for popular 7.2v camcorders—it can provide runtime of as much as 2 to 5 times of the battery provided with the camcorder, it can run a 10W camcorder for more than 7.5 hrs.



Camcorder shown with Elipz Battery and light



Kits include: Battery, camera-adaptor cable and charger

Available for: Canon #ANELIPZCK, Panasonic #ANELIPZPK, Sony #ANELIPZSK or for Sony HVR-Z1U #ANELIPZS1K..... **279.95**
Elip Z Cable for JVC GY-HM100 #ANJ100ADPELP **79.09**
Elip Z Cable for Panasonic AG-HMC150 #ANP150ADPELP **79.09**



Battery and Power Kits
for Sony PMW-EX3

ANQREXK1 Battery and Power Kit 1 features a Gold Mount, charger and battery to professionally power the Sony camcorder for an extended period of time. Kit Includes: • Dionic 90 Battery • Tandem 70 Charger • QR-EX3 Gold Mount For Sony PMW-EX3 #ANQREX3K1 **1017.95**

ANQREXK2 Battery and Power Kit 2 Kit Includes: • QR-EX3 Gold Mount for Sony PMW-EX3 • Two Dionic 90 Lithium-Ion Batteries • T2 2-Position Charger and 70-watt AC Power #ANQREX3K2 **1764.95**

Coco-EX3 Power Adapter

Specially designed for the Sony PMW-EX3, the COCO-EX3 is a compact and cost-effective method of powering accessories such as a light, on-board LCD monitor, or audio receiver. Designed to draw voltage from high capacity Anton Bauer Gold Mount or V-mount batteries, the Coco-EX3 attaches to the back of the camera in place of the battery. The Anton Bauer Gold Mount or V-mount battery then simply snaps onto Coco's special mounting plate.



- Run a camera light, hard-disk recorder, or an external LCD via a unique Twist D-Tap connector.
- Four Hirose 4-pin connectors to operate wireless audio accessories.
- COCO-EX3 and battery enhances the balance of the camera.

For use with V-mount Battery #BECOCOEX3V **429.95**
For use with Anton Bauer Battery #BECOCOEX3AB **429.99**
For use with BP-U60 Battery #BECOCOEX1 **394.95**

SERIES7 SL-50 Lithium-Ion 7.2V Battery System

The SL-50 battery will power 7.2v camcorders which is a considerable upgrade in runtime of up to 50% longer than batteries offered with the camcorders. Coupled with the Series-7 camera mount adapter, incorporating a 4-stage LED readout with temperature and fuse protection. Requires the Series-7 BC-L1 Quick Charger.

7.2V Lithium-Ion 50W/7000mAh Battery #SESL50 **104.95**

Adapter Plates available for:

Sony "L" Series #SES7SHD, Panasonic CGR-D Series #SES7PDVX, AG-HVX200 #SES7PHVX, Canon GL-2 #SES7CGL, Canon XL-2/XL-H Series Camcorders #SES7CXLHL, JVC GY-HD100/110U #SES7JVC **33.50**



SL-50



Quick Battery Chargers:
BCL-1 - for Series-7 SL-50 Batteries #SEBCL1 **133.50**
BCL-1S - for Sony L Series Batteries #SEBCL1S **146.50**
BCL-1P - for Panasonic CGR Series Batteries #SEBCL1P **110.00**
BCL-2 - Dual Charger for SL-50 Batteries #SEBCL2 **259.95**

Battery Kits with 2 SL-50 Batteries, Adapter Plate and Charger:

For **Panasonic** DVC and DVX Camcorders #SES7PDVXX, HVX-200 #SES7PHVXX, for **Sony** FX-1, Z1-U, VX Series, PD Series FX7 #SES7SHDK, for **Canon** XL-1/1S/2/H1 #SES7CXLHLK2 **359.50**
For **JVC** GY-HD100U #SES7JVCK **Call**
for **Canon** GL-1/GL-2 #SES7CAG1K **368.95**

New Battery Kit 2 with Power Plate to power Camcorder and video light Kit includes: 2 SL-50 Batteries, BCL-1 Battery Charger for SL-50 and S7-XLHL-L Battery Adapter Plate - for **Canon** XL-1, XL-1S, XL-2 and XL-H1, **XD-L56S** LED Fixture for Series 7 and Sony L Series Batteries #SES7CXLHLK2 **599.95**



SSL-VBG50 Battery

High Capacity 7.4v Lithium-Ion Battery for Panasonic

Designed to work with Panasonic's AG-HM70 and AG-HMC150 series. Provides three hours of recording time with a capacity of 5000mAh. 3 LED power indicator to provide a quick reference of the remaining level of power. 'secured' interface between the battery and the camcorder allows optimized operation and an analog battery level can be displayed in the camcorder viewfinder.

SSL-VBD50 7.4v /5000mAh Battery (#IDSLVBD50) **77.50**
SSL-VBG50 7.4v /5000mAh Battery (#IDSSLVBG50) **129.95**



SSL-VBG50



LC-VWP

LC-VWP Charger

Dual Channel Charger for SSL-VBG50

Designed to quick charge two SSL-VBG50 batteries at the same time. The charger is also compatible with Panasonic VW-VBD50, VW-VBG6, VW-VBG260.

LC-VWP 7.4v Dual Charger (#IDLCVWP) **119.95**

SSL-VBG50 / LC-VWP Charger Kit

Battery and Dual Channel Charger

For Panasonic AG-HMC70 and AG-HMC150. Kit includes: Two SSL-VBG50 Li-Ion batteries, and LC-VWP dual-battery quick charger.

SSL-VBG50 Battery and LC-VWP Charger (#IDSSLVBG50K) **359.95**



A-E2EX3 mounted on camcorder

Endura Power Adapter

for Sony PMW-EX3

IDX V-Mount Adapter enables IDX Lithium Ion Technology to complement the Sony PMW-EX3 Camera System. Specifically engineered to interconnect the IDX powerful batteries to the popular camera. It also supports the matching PMW-EX30 recording deck. The adapter's D-Tap feature enables use of on-board accessories such as IDX' X5-Lite.

A-E2EX3 Adapter for Sony PMW-EX3 (#IDAE2EX3) **169.95**

Endura Power Adapter Kit 1 for Sony PMW-EX3. Kit includes: • **A-E2EX3** Power Adapter for Sony PMW-EX3 • **E-7S** Endura Lithium-Ion V-Mount Battery • **VL-2** Battery Charger/Power Supply • **CA-4XLR** 4-pin XLR Male to 4-pin XLR Female Cable - 10' (#IDAE2EX3K1) **882.50**

Endura Power Adapter Kit 2 for Sony PMW-EX3. Kit includes: • **A-E2EX3** Power Adapter for Sony PMW-EX3 • **Two E-7S** Endura Lithium-Ion V-Mount Battery • **VL-2** Battery Charger/Power Supply • **CA-4XLR** 4-pin XLR Male to 4-pin XLR Female Cable - 10' (#IDAE2EX3K2) **1224.95**



SERIES7

EX-L96 96WH 14.4v Lithium-Ion Battery

The EX-L96 delivers up to 50% longer runtimes for the Sony EX1/EX3 than Sony's own EX battery. Features 4-LED remaining power gauge and on-board Powertap for powering 12v accessories (such as lights or monitors).

#SEEXL96 **284.95**



Switronix Power Charger for PB70/NP-L60/EX-L96/XPL90 Batteries (#SWPB70C) **44.95**

800-947-1175 | 212-444-6675 Quick Dial: 821

Power Solutions for 14.4 Camcorders



TrimPac 14 / ProPac 14 Series 14.4v NiCad Brick Batteries

These lightweight batteries operate a 25-watt camcorder and light for up to 1.5 hours, with more energy than two slide-in NP style batteries. Display shows remaining battery time.

TrimPac 14 (45Wh) (#ANTP14)	189.95
Digital TrimPac 14 (#ANDTP14)	249.95
ProPac 14 (65Wh) (#ANPP14)	294.95
Digital ProPac 14 (#ANDPP14)	299.95



Digital HyTron Series

Nickel Metal Hydride 14.4v Batteries

Offer powerful chemistry and reliable operation for all shooting applications. Utilizing Anton-Bauer's InterActive technology, the battery's onboard "Fuel Computer" monitors power and operating characteristics to ensure optimal—and accurate—performance.

50Wh (#ANH50)	264.95
100Wh (#ANH100)	399.95
140Wh (#ANH140)	499.95



Dionic 90 / 160 14.4v Lithium-Ion Batteries

High-capacity battery system compatible with Anton Bauer InterActive 2000 and Titan Series chargers. They can run a typical 25-watt camcorder for over 3 or 5 hours respectively. Feature military-grade cell chemistry multiple safety circuits and real-time display of battery run time

Dionic 90 90Wh (#AND90)	399.95
Dionic 160 160Wh (#AND160)	949.95



Dionic HC High-Capacity 14.4v Li-Ion Battery

The 91-watt Dionic HC lithium-ion battery is capable of delivering up to 10 amps for high current draw applications, including on-camera lighting. Can run a 40w HD camcorder for over 2 hours. #ANDHC

Dionic-HCX Li-Ion Battery with Built-in Motion Sensor #ANDHCX



BPLI-95 V-Mount Lithium-Ion Battery

Lithium-ion 14.4v/95Wh V-mount battery for professional camcorders and decks. Features overcharge/discharge/current protection. LED power-status indicator.

#BEBPLI95.....**224.95**



HD60 • HD150 60W & 150W On-Camera Batteries

Rugged and serviceable, Frezzi's HD camera batteries feature a sure grip case design while delivering maximum runtime for HD cameras. They are travel friendly with no restrictions and provide unmatched performance and cycle life. The 60WH mini brick camera battery can handle loads up 80W, the HD-150 can handle high discharge rates up to 200W. Designed for cameras with an Anton Bauer® bracket.

HD-60 60WH 14.4v NiMH mini battery for A/B mount (#FRHD60)	247.50
HD-60HG 60WH 14.4v NiMH mini battery, A/B mount with Energy Gauge (#FRHD60HG)	329.95
HD-150 150WH 14.4v NiMH battery, A/B mount (#FRHD150)	539.95
HD-150HG 150WH 14.4v NiMH battery, A/B mount with Energy Gauge (#FRHD150HG)	Call



PAG L-95E Series

14.8v/95Wh Power Circle Lithium Ion Battery

These sophisticated batteries incorporate a 4-segment "power-circle" micro-driven coulometric capacity indicator. Increased run time for packages up to 35W.

PAGLok Mount (#PAL95EP).....	369.95
V-Mount (#PAL95EV).....	324.95



Endura Series E7/E10 Lithium-Ion 14.4v V-Mount Batteries

High power, lightweight, and ergonomic, these batteries feature real-time transmission of capacity to the camera's viewfinder as well as five external LED lamps for easy reference of remaining power.

E-7S 71WH (#DE7S).....	208.99
E-7 71WH Stackable, Digi-View Display (#DE7).....	284.69
E-10S 98WH (#DE10S).....	289.95
E-10 98WH Stackable, Digi-View Display (#DE10).....	364.95



E-HL9/HL-9S 14.4v V-Mount High Load Batteries

Designed for power-hungry HD cameras, the E-HL9 support sustained high current loads. Take continuous draw of up to an impressive 10 Amps. 50% higher discharge rate. 10% longer battery viability at the 500-cycle level.

E-HL9S 14.4v DC, 88WH with 3 Power Status LEDs, (#DEHL9S)	393.99
E-HL9 14.4v DC, 88WH with 5 Status LEDs, Digi-View (#DEHL9)	473.29

Elite Endura 14.4v, 142 Wh V-Mount Battery

Elite 14.4v DC, 142WH Lithium-Ion Battery, (#DEE).....**599.95**



NP-L7 • NP-L7s 14.4v NP-1 Style Lithium-Ion Batteries

The NP-L7S features LEDs to display battery power status, tough ABS case and high temperature battery protection circuit. Otherwise the same, the NP-7L adds 'Digi-View' a special communication contact that transmits the current battery capacity in real time to the viewfinder "Fuel Gauge" included in many cameras and camcorders.

L7s 14.4v, 1WH (#DNPL7S).....	173.95	L7 14.4v, 71WH with Digi View (#DNPL7).....	294.95
--------------------------------------	---------------	--	---------------



14.4v Lithium-Ion Batteries

No memory digital Li-Ion battery pack. Use with a detachable battery watch (D4200) to monitor real-time capacity for maximum power conservation and optimal performance. Also feature an intelligent control circuit for temperature, current and voltage protection with a 4 level LED power indicator.

Batteries for Sony V-Mount

#VAD8081S 88Wh	271.95
#VAD8111S 126Wh	399.95
#VAD8161S 190Wh	524.95
#VAD4200 Battery Status Testing Device with LCD, Back Light Readout	99.95

Batteries for A/B Mount

#VAD8081A 88Wh	284.99
#VAD8111A 126Wh	399.95
#VAD8161A 190Wh	524.95



S-8170 Series 14.4v Lithium-Ion Split Battery

When affixed to a camcorder, the S-8170 is a powerful 160W (80Wh x 2) lithium-ion battery. It can be divided in half to meet domestic and international transport restrictions.

Sony V-Mount (#VAS8172S).....	449.95
Anton Bauer Mount (#VAS8170A).....	449.95



XP-L90 • XP-L130

90WH and 130WH 14.4v Lithium-Ion Batteries

They feature 2-pin output connectors, power gauge and information storage. The XP-L90 is a 90WH (Watt Hour) battery, the XP-L130 a 130WH battery. Also available with LCD capacity display.



XP-L90

For Anton Bauer (SWXPL90A)	449.95
For Sony V-Mount (SWXPL90S)	449.95
For A/B with LCD (SWXPL90A)	544.95

XP-L130

For Anton Bauer (SWXPL130A)	611.95
For Sony V-Mount (SWXPL130S)	699.95
For A/B with LCD (SWXPL130A)	802.50

XP-L95 Red

V-Mount Battery Pack for RED ONE

- High-capacity Li-Ion • Communicates with Camera • Integrated Powertap
 - 2nd Generation DURA Casing
- #SWXPL95RED.....**399.95**





SC-302 Series

Multi-Chemistry Battery Chargers

Dual-bay sequential chargers support Ni-Cad, NiMH, and Lithium-Ion batteries and use a variety of mounts. • 100–240V 50/60 Hz

- Charge digital and non-digital batteries

NP-1 Type (#VASC302).....	164.99
V-Mount (#VASC302S).....	324.99
A/B Mount (#VASC302A).....	324.99

SC-304 Series

Multi-Chemistry Battery Chargers

2-bay and 4-bay sequential chargers that support Ni-Cad, NiMH, and Lithium-Ion batteries.

- 100–240V 50/60 Hz power.

4-Bay NP-1 Type (#VASC304).....	279.99
2-Bay V-Mount (#VASC304S).....	309.50
2-Bay A/B Mount (#VASC304A).....	349.95



VL-2 Plus / VL-2S Plus / VL-4S / VL-4Si

Lithium-Ion Battery Chargers

- Endura V-mount • LED condition indicator • Intelligent charging • 100-240VAC 50/60 Hz

VL-2 Plus 2-Channel 60W Poser Suply (#DVL2).....	514.95
VL-2S Plus 2-Channel Simultaneous Charger and Power Supply V-Mount (#DVL2S).....	589.95
VL-4S 4-Channel (#DVL4S).....	769.95
VL-4Si 4-Channel w/PC Information Retrieval (#DVL4Si).....	1069.95
VAL-4Si 4-Chan. Plus 4-Channel Expansion Charging, w/PC Info Retrieval (#DVAL4Si).....	1699.95

JL-2Plus Dual NP-1 Charger/Power Supply

- Sequential charger • 100-240 Volts AC, 50/60Hz • NP-1: Ni-Cad/NiMH/Lithium-Ion support
- 60-watt 4-pin XLR port • Battery condition indicator

#DJL2PJ.....	Call
--------------	------

IA-60 / IA-200 / IA-300 Camera DC Power Supplies

- Compact, metal case • AC 100/240V 50/60 Hz • 10' 4-pin XLR cable included

IA-60A 1-Ch, 4.4Amp, 12V/60W (#DIA60A).....	249.95
IA-200A 2-Ch, 7amp, 12V/100W (#DIA200A).....	474.95
IA-300A 3-Ch, 15amp, 12V/210W (#DIA300A).....	654.99



AC-100 On-Camera AC Power Supply

A multi-functional AC adaptor, the AC-100 can be directly mounted to a V-Mount camera or used individually away from the camera. The unit runs silently at low loads with a temperature-activated low noise fan at higher loads

- Input Voltage : AC 100-240V 50/60Hz • Output Voltage : 14.5V
- DC Power Output: XLR Connector

AC-100 100W On-Camera AC Power Supply (#DIAC100).....	329.95
---	--------

bescor PSA-124 Power Supply for 4-Pin XLR Equipment

Lightweight (1.2 lbs) .4amp power supply. Operates with either 110V or 220V AC. Includes an IEC connector as well as a standard US AC cord. The 64" cord is terminated with a 4-pin female XLR connector for a direct equipment connection.

PSA-124 Power Supply for 4-Pin XLR (#BEPSA124).....	134.95
---	--------



Titan 70/Titan Twin AC Adapter/Chargers

- Charge any Logic Series Gold Mount battery
- InterActive® communication between battery & charger
- Three-stage charge sequence: charge time is 2 hrs or less

Titan 70 On-Camera AC Adapter/Charger (#ANT70).....	524.95
Titan Twin Dual 60W Charger (#ANTT).....	624.95



Titan 70 on camera



Titan Twin

Titan T2/TWQ/D-2722/Q-2702

Gold Mount Interactive Chargers

Simultaneous chargers for A/B Logic Series battery, with InterActive® communication. T2 charges one battery and simultaneously powers camcorder.

Titan T2 2-Position Charger/Power (#ANTT2).....	889.99
TWQ 4-Position Charger Only (#ANTTWQ).....	1189.95
D-2722 2-Position (#AND2722).....	1099.95
Q-2702 4-Position (#ANQ2702).....	1350.29



Titan T2

TM4 Four Position Gold Mount Charger

The TM4 is a four position simultaneous fast charger designed to safely and reliably charge Gold Mount batteries twice as fast as the TWQ. Delivering all of the capabilities and efficiency of the field proven InterActive system, the TM4 is the perfect charger for the professional who needs the fastest battery turnaround time while in the field.

- 70 watt power supply output • 100-240 volt wide range input
- 7 full-time operating charge terminations • Logic Series compatibility

TM4 Four Position Gold Mount Charger (#ANTM4).....	1799.95
--	---------



GP-2LSJ / GP-2LAJ / XC-2LAN / 2LSN

Multi-Chemistry Charger/Power Supply

- Dual-bay sequential chargers that support Ni-Cad, NiMH, and Lithium-Ion batteries • 12V/50W 4-Pin XLR power connection

GP-2LSJ Sony V-Mount (#SWG2LSJ).....	532.95
GP-2LAJ A/B Mount (#SWG2LAJ).....	534.50
XC-2LAN A/B Mount (#SWXC2LA).....	614.50
2LSN Sony V-Mount (#SWXC2LS).....	614.50

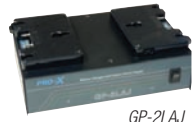

GP-2LAJ



GP-LS Single Position V-Type Charger/Power

- Combines the functionality of a single position V-mount charger with a 12V DC 90W camera power supply. • Charges NiCad, NiMH, and Lithium-Ion batteries
- 12V/90W 4-pin XLR power connection

#SWGPLS.....	469.95
--------------	--------



TC-40 Series

Four-Position Simultaneous Battery Chargers

Simultaneous quick chargers for specific Canon, JVC, Panasonic, and Sony 7.2V, lithium-ion battery packs.

- AC 110/220 and 12V DC • Dynamic power management (DPM) minimizes battery charge time

Panasonic CGR-D Series (#D04PCPQ).....	344.95	Sony "L" and "M" Series (#D04PCSQ).....	369.95
Canon BP-900 Series (#D04PCCQ).....	344.95	JVC BN-V428 Series (#D04PCJQ).....	349.95



TC-400 Four-Position Battery Charger

- Fast, simultaneous charging of battery packs up to 5600 mAh
- LCD screen shows charge progress
- 100–240V AC power supply

f/Sony PD-170 / VX-2100 (#D04PCS).....	549.95
f/Panasonic DVX/HVX (#D04PCP).....	499.99
f/Canon XL-2 (#D04PTDMC).....	599.95

f/JVC HD100 (#D04PTDMCJ).....	569.95
f/Sony EX (#D04PCSEX).....	619.99

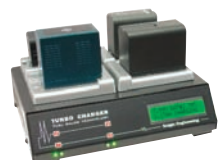

bescor

HP-3 SERIES 12V Battery Packs

At 2.8 lbs, these half-pint batteries are lightweight and memory-free.

- Capacity: 36 Wh / 3 Amh
- Run Time: with 10w-150 min.
with 50w Light-30 min.
with 100 w Light 15 min.
- Charge Time: - 8 Hours



- HP-3 with Cigarette Plug #BEHP3..... **39.95**
- with Cigarette Plug and Auto Charger #BEHP3ATM **72.50**
- with XLR Plug #BEHP3XLR **55.95**
- with XLR and Auto Charger #BEHP3XLRATM **86.95**

NMH-65 SERIES

14V NiMH Clip-On Battery Packs

The NMH-65 series batteries are high-performance, lightweight Nickel Metal Hydride (NiMH) battery packs. 14.4V/4.5 amp-hrs, memory- and maintenance-free, the NMH-65VA has a Sony-style V-mount that will fit pro camera V-mounts.



- Shoulder Pack #BENMH65A **Call**
- V-Mount Pack #BENMH65VA..... **Call**

LA-145 / LA-148

14V Shoulder/Belt Packs

The LA-145 shoulder pack includes cigarette and 4-pin XLR connectors. The LA-148ATM battery belt includes cigarette connector and 4-pin XLR connector w/2" lead. The LA-148XLATM includes two 4-pin XLR connectors, with 2" and 6' leads.



- LA-145 Shoulder Pack
54wH/4.5aH #BELA145ATM..... **144.95**
- LA-148 Belt Pack 112wH/8aH #BELA148ATM..... **227.95**
- LA-148 Belt Pack 112wH/8aH #BELA148XLATM **251.95**

MM-7 / 9 / 12 12V Battery Shoulder Packs

BES-015 / 018 12V Battery Belt Packs

Power solutions available with cigarette or 4-pin XLR connections, plus a range of charging options.

SLM-5 / 18ATM 12V Slim Battery Packs

SLM packs include an automatic shut-off charger. SLM5 is a single pouch, while the SLM-18ATM is a 4-pouch belt.



NMH-54 / 90 SERIES

12V NiMH Clip-On and Waist Battery Packs

- NMH-54 With Cigarette Connector #BENMH54A..... **154.95**
- NMH-54 4-Pin XLR Connector #BENMH54XLR..... **174.50**
- NMH-90 with 4-Pin XLR and a Cigarette Connector
(no charger) #BENMH90XLRNC..... **244.95**
- NMH-90 with Cigarette Connector (Auto charger)
#BENMH90A..... **314.95**
- NMH-90 4-Pin XLR and a Cigarette Connector
(Auto charger) #BENMH90XLR..... **314.95**

Model	MM-7	MM-9	MM-12	BES-015	BES-018	SLM-5ATM	SLM-18ATM	NMH-54	NMH-90
SKU#	#BEMM7	#BEMM9	#BEMM12	#BEBES015	#BEBES018	#BESLM5ATM	#BESLM18ATM	#BENMH54	#BENMH90
Capacity	4.3 Amh	8.6 Amh	17.2 Amh	14.4 Amh	18 Amh	4.3 Amh	17.2 Amh	4.5 Amh	7.5 Amh
Run Time with 10w	5 hrs	10 hrs	25 hrs	15 hrs	18 hrs	5 hrs	25 hrs	5+ hrs	8+ hrs
with 50w Light	50 min	120 min	240 min	3 hrs	4 hrs	50 min	240 min	1 hr	2 hr
with 100w Light	35 min	45 min	120 min	85 min	1.8 min	35 min	120 min	30 min	50 min
Charge Time	5 hrs	10 hrs	13 hrs	16 hrs	19 hrs	5 hrs	13 hrs	14 hrs	8 hrs
Weight	3.2 lbs	7.3 lbs	14 lbs	11 lbs	12 lbs	3.2 lbs	14 lbs	1.2 lbs	4 lbs
Price	54.95	59.95	93.95	103.50	113.50	74.95	239.95		



PRB-7 / 8 / 9 / 12 / 15 / 18 / 154 / 24 12V Battery Belt Packs

Power solutions available with cigarette or 4-pin XLR connections; quick-release belt fits 28"-50".

Model	PRB-7	PRB-8	PRB-9	PRB-12	PRB-15	PRB-18	PRB-154	PRB-24
SKU#	#BEPRB7	#BEPRB8	#BEPRB9	#BEPRB12	#BEPRB15	#BEPRB18	#BEPRB154	#BEPRB24
Capacity	7 Amh	8 Amh	9 Amh	12 Amh	14.4 Amh	18 Amh	14.4 Amh	24 Amh
Run Time with 10w	7 hrs	8 hrs	9 hrs	14 hrs	16 hrs	19 hrs	18+ hrs	30+ hrs
with 50w Light	1.3 hrs	1.6 hrs	1.8 hrs	2.4 hrs	3 hrs	4 hrs	3 hrs	5 hrs
with 100w Light	35 min	40 min	45 min	1.25 hrs	1.4 hrs	1.65 hrs	1.4 hrs	2.4 hrs
Charge Time	16 hrs	17 hrs	18 hrs	13 hrs	15 hrs	18 hrs	16 hrs	26 hrs
Weight	5.5 lbs	5.5 lbs	6 lbs	8.5 lbs	11 lbs	12 lbs	11 lbs	18 lbs
Price	74.95	69.95	69.95	98.95	108.50	132.95	132.95	166.50



LibertyPak

LB400V Power-Belt

The pack features 12VDC 4-Pin XLR power output capable of powering video cameras at 26A, with an output of 320W. The pack features SLIC technology which allows the unit to function in extreme weather conditions. The pack can function up to 2000 cycles, for 6 hours without a recharge. Additionally, the LB400V can be charged by a number of sources, including their own portable solar panel system.



- LB400V Power Belt #LILB400V..... **2099.95**

LP 800 Portable PowerPak

Portable 24VDC power with a peak output of 1100W. The battery is encased in a durable and lightweight case, with an operating temperature rating of -4°F (-20°C), making it extremely useful in extreme climate situations. With a cycle life of over 2000 charges, rest assured that the PowerPak is ready to go the extra mile.



- LP 800 Portable PowerPak #LILP800..... **3493.95**

COOL-LUX™

L-10 SERIES

12V Smart Power Battery Packs

The memory-free Smart Power 12V/120Wh battery belts come complete with heavy-duty 16-gauge wiring, slip-proof connectors, and reliable operating power. They feature five color LED power-indicator lights.



- BC-3074 with 4-pin XLR and cigarette connector #COBC3074..... **269.95**
- BC-3070 with Two 4-pin XLR connectors #COBC3070..... **279.95**



UL-2 Series

On-Camera Pro 12/14V Ultralight-2 Series

The most widely-used ENG compact on-camera light, the UL-2 series incorporates a 25W (BAB) lamp, Power-Tap connector and patented camcorder mount system.



- UL2-6** Light with 6" PowerTap Cable (#ANUL26).....**184.19**
- UL2-20** Light with 20-inch PowerTap Cable (#ANUL220)....**189.99**
- UL2-28** Light with 40-inch PowerTap Cable (#ANUL2L)....**229.95**
- Dimmable Kit** UL-2-6 w/25 & 50W Lamps (#ANULDP)....**433.95**

UltraDAYlight

On-Camera HMI Light

Incorporating a built-in ballast in its housing, the UltraDAYlight adds the high efficiency of HMI lighting to any Ultralight system. Provides 5600K light at less than half the power required by tungsten or halogen lamps, all without the need of dichroic adapters. Perfect for daylight fill situations, the UltraDAYlight can be converted to tungsten with the addition of the optional UL-GEL KIT (not included).



- UltraDAYlite** On-Camera HMI Light (#ANUDL).....**888.95**
- UL-GF Gel Frame** Gel or Silk Holder (#ANULGF).....**49.99**
- UL-GELKIT** Includes 40 Pre-Cut Gels (#ANULGK).....**30.59**

ULHM-LED

9W LED Head Module

Add another look to your on-camera lighting by easily swapping out already available HMI and tungsten modules. No need to remove the entire mount—just slip the ULHM-LED into a UtraLight 2 base (not included). Heat-and flicker-free, the module's 0-100% dimmable 5600K light consumes only 1/3 the power of a tungsten lamp. Included filter provides adjustable color temperatures down to 3200K, so you can match light sources. Great for dealing with unpredictable lighting at news events and in documentary settings.



- ULHM-LED** 9W LED Head Module (#ANULHMLD).....**514.95**
- UL2-20BASE** UtraLight 2 Base Mount (#ANUL220B).....**144.50**

EledZ

4.5W On-Camera LED Light

Designed to mount atop today's smaller handheld camcorders, the EledZ produces heat-free, flicker-free illumination while drawing power from the ElipZ 10K battery (optional), which can power both camera and light for up to 5 hours. A dimmer allows you to control the level of light from 0 - 100%, while an included filter lets you change color temperature from 3200K to 5600K. You can also adjust the light's angle of view using the multilateral arm built into the mount.



- EledZ** 4.5W On-Camera LED Light (#ANELEDZ).....**344.95**



LED-25

25-Watt On-Camera LED Light

Compact, daylight-balanced 25-watt LED light allows daylight balanced light without filters or ballasts and doesn't burn out like regular lamps. Includes 2 AA batteries for up to 4 hours of shooting time. Mounts to a standard camcorder shoe mount. With side bracket.



- #BELED25.....**34.95**
- With VB-50 Universal Shoe Mount Adapter (BELED25K1).....**44.95**
- With Pearstone Cold Shoe Adapter for Sony (BELED25K2).....**49.95**
- With Pearstone Cold Shoe Adapter for Canon (BELED25K3).....**49.95**

LED-40 On-Camera 40W LED Light

On-camera, daylight balanced LED light that provides the equivalent of 40W of illumination. Suitable for both video and DSLR cameras, the LED-40 offers a wide beam that reaches over 20 feet and runs on standard alkaline or NiMH AA batteries (housed in an easy-access internal battery compartment). With its universal shoe mount and included side arm bracket, this bright, compact light can also be mounted to one side or on a stand, for off-axis illumination.



- LED-40** 40-Watt LED Light (#BELED40).....**49.95**
- LED-40** Shoe Mount Adapter Kit 1 (#BELED40K1).....**59.95**
- LED-40** Swivel Shoe Adapter Kit 2 (#BELED40K2).....**59.95**

LED-50DA On-Camera 50W LED Light

On-camera, dimmable, daylight balanced (6500K) LED light. Its 30 LED bulbs produce an ultra bright beam that's the equivalent of a 50W tungsten bulb, with a reach of up to 25 feet. Suitable for both video and DSLR cameras, the LED-50DA is powered by 4 standard alkaline or NiMH AA batteries, and includes a clear frosted filter for softening glare as well as an amber 4300K correction filter for shooting indoors.



- LED-50DA** 50-Watt LED Light (#BELED50DA).....**94.95**
- LED-50DA** Shoe Mount Adapter Kit 1 (#BELED50DAK1).....**104.95**
- LED-50DA** Swivel Shoe Adapter Kit 2 (#BELED50DAK2).....**104.95**

MPL12V Multi-Watt On-Camera Lights

Compact, 12v DC on-camera light utilizes switchable 20W and 35W bulbs for both single and tandem multi-watt output. Twin barn doors aid in direction, while diffusion filter softens. An excellent choice for large or small camcorders.



- Includes:**
- Compact lamp head • Diffusion filter
 - 20W and 35W 12VDC bulbs • Vertical barn doors
- MPL12V** Multi-watt, On-Camera Light with Cigarette Plug Connector (#BEMPL12V).....**59.95**
 - MPL12VX** Multi-watt, On-Camera Light with XLR 4-pin connector (#BEMPL12VX).....**59.95**

LED-150

150W Dimmable LED Video Light

The LED-150 uses 5 LED bulbs powered by any 12V battery with cigarette socket. Draws minimal power even at full wattage for long battery life while its aluminum alloy case is never too hot to touch. The light's 80° spread and 1100Lux/1M intensity is dimmable from 150 to 25 watts, and its 5800K color temperature can be warmed to 4500K with the included filter. A combined universal shoe and 1/4" x 20 mounting thread allow use on any tripod, stand, or camera shoe mount.



- LED-150** (#BELED150).....**134.95**
- LED-150** with NMH-54NC NiMH Battery and Charger (#BELED150K1).....**279.95**
- LED-150** with MM-7NC Lead Acid Battery and Charger (#BELED150K2).....**214.95**
- LED-150** with Power Tap Connector (#BELED150PT).....**349.95**

LED-60K

60W LED Compact Light & Battery Kit



- Completely Dimmable
- 5600° K • Includes Battery & Charger • Interchangeable Filters
- #BELED60K.....**84.95**
- LED-60AAK** 60W LED Light & Battery Box (#BELED60AAK).....**94.95**

MPL-313

On-Camera 12v Light

Compact on-camera light designed with a mesh screen housing for cooler operation. Includes 4-way barn doors, diffusion filters and 35W lamp.



- With Cigarette Plug (#BEMPL313C).....**74.95**
- With XLR 4-pin (#BEMPL313X).....**79.95**
- With Powertap Connector (#BEMPL313P35).....**89.99**
- MPL-313X with SLM-5XLR Battery (#BECK5XLRATM).....**174.50**
- MPL-313X with MM-7XLR Battery (#BECK7XLRATM).....**183.95**
- MPL-313C with NMH-54XLR Battery (#BECK54XLRATM).....**251.95**
- MPL-313X with NMH-54 Battery (#BECK54ATM).....**227.95**

VS-50 / 65 & KLK-50XT / 65XT

On-Camera 12v Lights and Kits

Soft, diffused lens provides an even light spread and 2 vertical barn doors.



- VS-50** with 50W (DC) Lamp (#BEVS50).....**39.95**
- VS-65** with 50W (DC) & 100W (AC) Lamps (#BEVS65).....**49.95**
- KLK-50XT** with MM-7 (12V/86.4Wh) Battery (#BEKLK50XT).....**94.95**
- VS-65** with MM-7 (12V/86.4Wh) Battery (#BEKLK65XT).....**99.95**

BARBERTECH
VIDEO PRODUCTS

LL36

Dual Powered LED Light



The LL36P is a lightweight on-camera, daylight- balanced LED light source. The built-in diffuser insures directional but soft light with a 600 lumen output that far exceeds its nominal wattage. The LL36P runs off of its built-in lithium-ion battery for 45-60 minutes. Charges in three hours via supplied 120/220v charger (which also doubles as an AC adapter). Includes four plug adapters allowing the charger/AC adapter to be used almost anywhere in the world.

#BALL36P94.95

COOL-LUX™

Digi-Lux

On-Camera 12v Dimmable Light

The Digi-Lux is the smallest dimmable on-camera, professional video light in the world. Adjustable between 0 and 35 watts, the Digi-Lux can operate from 12v, 13.2v or 14.4v batteries. The maximum watt is 75w @ 12v, DC only. Includes shoe mount.



With Power Tap Cable (#COLK2512)149.95

With 4-Pin XLR Cable (#COLK2511).....159.95

With Power Tap Cable and Soft Box (#COLK2514)213.50

With XLR Cable and Soft Box (#COLK2513).....222.95

With XLR, Soft Box and BC-3054 Battery Belt COLK2515) ..222.95



iLED-155 On-Camera Light Kit

With its built in battery mount, dimmer, and small size, the iLED-155 requires a fraction of the power of other on-camera lights for an unbeatable price. The kit consists of the iLED-150 light, three color correction gel filters, battery, charger, AC adapter, Sony compatible battery and charger, camera shoe mount and soft case.



iLED-155 LED Light w/ Sony plate (#KILED155S).....334.95

iLED-155 LED Light w/ Canon plate (#KILED155C).....334.95

iLED-155 LED Light w/ Panasonic plate (#KILED155P).....334.95

Multi-K Variable Color Temperature LED Light

No longer will you need to fumble with gels or fiddle with white balance when mixing light sources.

The Multi-K lets you dial in the color temperature you need, using a combination of three differently colored lights – red, white, and yellow – to provide a range of color temperatures from 2800-6500K. So whether you're shooting inside, outside, in front of a window or next to a candle, the Multi-K lets you match the available light source.



• 144 LED Bulbs (Red, White, & Yellow)

• 50W Tungsten Equivalent • Less Than a Pound

• Takes 6 AA Batteries. With case, shoe mount and AC adapter.

Multi-K LED Light (#KIMULTIK).....489.95

Frezzi
ENERGY SYSTEMS

Micro-Fill

35W On-Camera Light



More compact than the Mini-Fill, this 35W/12v DC light is only 1.6" wide and less than 4" long, making it perfect for smaller HDV cameras. It features a diffusion lens, a universal shoe with 1/4"-20 mount. Also available with a dimmer and a choice of connectors

Standard Micro-Fill with on/off Quartz

MRF-4X w/ 4-pin XLR connector and 4' cable (#FRMRF4X).....194.95

MRF-PT w/ Power-tap connector, 2' cable (#FRMRFPPT).....194.95

MRF-PTS w/ Power-tap connector, 1' cable (#FRMRFPPTS).....158.95

Dimmer Micro-Fill Dimmable Quartz

MRFC-4X w/ 4-pin XLR connector, 4' cable (#FRMRFC4X).....285.95

MRFC-PT w/ Power-tap connect., 2' cable (#FRMRFCPT) ..289.50

MRFC-PTS w/ Power-tap connect., 1' cable (#FRMRFCPTS).....285.95

Mini-Fill

75W On-Camera Light

Lightweight and compact, the Mini-Fill was developed to be tough and functional enough to illuminate a broadcast of a Mount Everest climb. High-efficiency 75W/12VDC lamps create high output with minimum power consumption. Includes 1/2" stud mount. Also available with a dimmer and a choice of connectors.



Standard Mini-Fill with on/off Quartz

MF-4X w/ 4-pin XLR connector and 4' cable (#FRMF4X)242.50

MF-PT 50W w/ Power-tap connector, 2' cable (#FRMFPT).....232.95

Dimmer Mini-Fill Dimmable Quartz

MFIC-4X w/ 4-pin XLR connector, 4' cable (#FRMFIC4X).....294.95

MFIC-PT 50W w/ Power-tap connector (#FRMFICPT)342.95

MFIC-PTS 30W w/ Power-tap, 1' cable (#FRMFICPTS)337.50

MRAX2

Dimmable 15-Watt Micro-Sun Gun HMI

Features the world's smallest 10W to 15W dimmable HMI lamp fixture with a self contained ballast and full spectrum 5600K daylight color balanced lamp. Perfect for outdoor daylight fill light applications.....Call or Log-on



Dimmable Micro Fill Light

For DSLR Cameras

Put away your flashes and switch to continuous lighting for your DSLR camera to improve all your images for still and video.

Frezzi's 6oz Dimmable

Micro Fill Light mounts to all DSLR

cameras shoe and is guaranteed to

improve all your images by offering more control

and matching exposure. On or off camera, Frezzi lights offer the

best quality and durability of any Mini lighting product. With a 35

Watt lamp, color temperature is warm and bright for perfect indoor

color matching and intensity control.....Call or Log-on



I·D·E

X5 LITE

50W Dimmable On-Camera LED Light



The X5-Lite puts forth 50 watts of daylight-balanced LED light, dimmable from 0-100%. A specially designed lens holder ensures consistent, uniform dispersal. Fitted with a universal shoe mount.

X5 Lite 50W dimmable on-camera light (#IDX5LITE)349.95

X5 Lite with Barndoor and tungsten filter kit (#IDX5KIT).....369.95



LUX-LED12

On-Camera Dimmable Lighting Kits

These 12v dimmable lights are daylight balanced and incorporate five LEDs that are focusable at 40- to 60° angles. Powered by Canon, Sony or Panasonic DV camera (7.2v) batteries, they include a power supply adapter, D-Tap cable and 2-leaf or 4-leaf barn doors.



Canon BP 2-Leaf Kit (#BELULEDBP).....849.95

Sony NPF-L 2-Leaf Kit (#BELULEDNPF).....849.95

Panasonic 2-Leaf Kit (#BELULEDCGA)849.95

Sony PMW-EX1 2-Leaf Kit (#BELULEDEX1).....1079.95

4-Leaf Kits available



Kino Flo Kamio 6E Series

Fluorescent Ring Light System

The Kamio 6E system uses a fluorescent ringlight to create a shadowless, soft key light with cooler run temperature, for added comfort in close-ups. Mounting to your lens, this unique ring system uses an on-camera electronic ballast (operated from battery or AC).



#KIK6ERL w/light, harness.....Call

#KIK6ESQ w/light, 12V on-camera ballast, cable, mounts.....Call

lowel

i-Light Series

Spot/Flood 12-14v Lighting Kits

The i-Lights are great on-camera lights that focus from spot to flood. They are fitted with the high intensity #2 reflector & prismatic glass to give an even flood & uniform spot. The i-Light "D" kits are dimmable.



With cigarette plug (#LOI01)149.99

Dimmable with cigarette plug (#LOI01).....270.99

With 4-pin XLR plug (#LOI02)156.95

Dimmable with XLR plug (#LOI02).....270.99

LITE PANELS™

Micro On-Camera LED Light

Powered by AA batteries, 5-12v DC power or DV battery (with optional DV plate) the Micro is a 0-100% dimmable 5600K daylight light. With supplied provided filters, users can warm the illumination or change to 3200K tungsten. LED technology offers heat free operation drawing only 3 watts of power. Integrated camera shoe with adjustable tilt mechanism allows for multiple mounting configurations



Micro 3W light without power (*LILPMICRO*) **264.95**
Micro Pro LED 9W light without power (*LILPMICROPRO*) **394.95**

MicroPro Hybrid

Continuous LED light combined with a "Flash".



This 9W fixture is the perfect complement for the motion-enabled DSLR cameras. Use the "Continuous Mode" for the camera's video capability and get beautiful wrap-around soft light. Or choose the "Flash" feature to produce a 400% brighter burst—just the ticket for a variety of still images. Runs off 6

AA batteries. The MicroPro Hybrid offers luminous, soft, directional lighting with warmth and great color characteristics.

MicroPro Hybrid Kit with Ball Head Shoe Mount, Sync Cable, 3 Gel Filters and Padded Carrying Case *#LIMPHK* **474.95**

DV Camera Kits

Dimmable LED On-Camera Light Kits



DV Camera Kits contain an on camera daylight balanced spot dimmer LED light with gels, camera mounting and camera adapter plate. The light draws only 7W of power while delivering 25 watts of illumination.

Flood Kit for Sony (*#LIMPDVDFCKS*) **599.99**
Spot Kit for Canon (*#LIMPVDSCKC*), Panasonic (*#LIMPVDSCKP*) or Sony camcorders (*#LIMPVDSCKS*) **749.95**

CLPK50PT / 50XLR / 20PT

25 Watt On-Camera Light Kit

A complete 25-watt LED lighting kit for a variety of applications. Includes battery with charger/adapter, gel assortment, tungsten-balanced filter, shoe mount, swivel arm and carrying case.



CLPK50PT Floodlight Pattern, Power Tap Connector (*#LIMP1LDFKPT*) **1094.95**

CLPK50XLR Floodlight Pattern, 4-Pin XLR Connector (*#LIMP1LDFKX*) **1094.95**

CLPK20PT Spotlight Pattern, Power Tap Connector (*#LIMPVDS1LKS*) **949.95**

PAG

Paglight C6

On-Camera 6v Light and Power Pack



Designed as an on-camera fill light, the C6 is fully focusable from spot to flood and runs exceptionally cool. It includes barndoors plus flip-up diffusion

and dichroic filters, all on a rotating accessory ring.

PL-C6 (1001) kit includes: On-camera (6v) 20W soft/flood adjustable light, shoe plate, battery and charger
#PAPLC6K **299.95**

SERIES7

XD-L56

On-Camera LED Light

The XD-L56 is an ultra-lightweight on-camera 20W LED light designed for DV and HDV cameras/camcorders. Draws only 6 watts while outputting the equivalent of 20 watts of 5600K daylight balanced light.



Powered by Series-7, Sony "L" or Panasonic CGR batteries. It is equipped with both 1/4"-20 and shoe mounts.

For use with Sony "L" Series Batteries (*#SEXDL56S*) **239.95**
 For use with Panasonic CGR-D Batteries (*#SEXDL56P*) **249.99**

SV

SV-840 On-Camera AC/DC Light



Along with its ability to operate on AC/DC power, this small, dual-purpose on-camera light has an all-aluminum casing and built-in dichroic filter. Comes standard with a variety of light controls.

- 100W (FCR) 3300K DC lamp
- Shoe and 1/4-20 stud mounting
- 4-leaf barndoors
- 4-pin XLR cable
- 4-pin XLR plug to AC cord

#SMSV840 **109.50**

SV-950

On-Camera Interview Light

This focusing spot-to-flood light comes with rotating barndoors, a built-in rotating dichroic filter, and a rotating diffusion filter—providing excellent light control in a small package.

- 100W (FCR) 3300K DC lamp
- 4-pin XLR cable
- 4-leaf barndoors
- Shoe and 1/4-20 mounting

#SMSV950 **167.50**



sachtler

Reporter LED D

On-Camera LED Light



With its single LED module, the Reporter 8LED avoids multiple shadows. Its input voltage of 6v-24v makes it ideal for both small and broadcast camcorders.

Includes quick-release, four-leaf barndoors and optional switchable lenses and tungsten LED module.

LED D on-camera light (*#SARLEDDL*) **298.50**

LED D Kit w/light, power connector, optic set, location set, and case (*#SARLEDDLK*) **926.95**

witronix

TL-50 TorchLED

30w Dimmable LED Light Fixture

The TL-50 provides the equivalent of 30 watts of 5600K daylight balanced light. Includes an integrated rechargeable battery pack for up to 3 hours of run time. Light output can be controlled via the onboard dimmer. Battery charges in only 2 hours and it has a 3-stage battery meter. Has 1/4-20 thread mounts on the top and bottom. Includes standard CTO, 1/4 frost, and Clear filter set.



TL-50 With battery, charger and filters (*#SWTL50*) **247.95**

TL-50 With shoe mount adapter (*#SWTL50K*) **253.50**

TL-68 45w with filter set, power tap cable (*#SWTL68*) **389.99**

TL-88 75w with filter set, power tap cable (*#SWTL88*) **549.99**

GP-H56S

DV/HDV On-Camera LED Light

Featherweight, the on-camera GP-H56 weighs just 0.6 lbs. and draws only 16W (from Sony L or Panasonic CGR series) batteries while producing the equivalent of 85W of daylight-balanced light. Dimmer control allows illumination from 10% to 100%. Light is on a moveable arm with two pivot points for maximum flexibility. Frosted and CTO pop-in gels and a focusing lens to convert the beam from 115° to 45° are built into the light.



GP-H56 For use with Panasonic Battery (*#SEGP56P*) **Call**

GP-H56 For use with Sony Battery (*#SWGPH56S*) **382.95**

VariZoom

S-2000 Dimmable On-Camera LED Light

The S-2000 combines 4 advanced LEDs with professional optic technology design to offer the equivalent of a 40-watt output at 5600k with power consumption of just 12 watts and low heat radiation. The light is dimmable from 100% to 5%, can last in excess of 100,000 hours and requires no spare filament bulbs. Includes barn doors, 3200K filter and diffuser.



S-2000 (*#IAVZS2000*) **269.95**

S-2010 with Canon battery clamp & shoe mount (*IAVZS2010C*) or Panasonic battery clamp & shoe mount (*IAVZS2010P*) **297.69**

Marshall

V-LCD4L-PRO-L

4" Broadcast Quality LCD Monitor

Enjoy a broadcast-quality picture in both color and black and white. A slim profile makes the monitor ideal for custom wall or panel monitoring in both mobile and fixed applications.



- Switchable dual video BNC inputs
- Wide viewing angle • Color, contrast, and brightness control

V-LCD4L-PRO-L (#MAVLC4PROL).....229.95

V-LCD4L-PRO-L Kit V-LCD4L-PRO-L monitor with battery pack and case (#MAVLC4PROLK).....**276.89**

V-LCD5.6-PRO

5.6" Camera Mountable LCD Monitor

The V-LCD5.6-PRO is a full featured LCD display with a built-in speaker and reverse image capability. Weighing just a lb. only 2-inches deep, it can mount on top of even the smallest video cameras. Ideal not only for framing and confidence but for location or impromptu playback when a larger monitor is impractical or absent. Has audio and headphone input. A tilting table stand is built-in.



V-LCD5.6PRO (#MAVLC56PRO).....247.49

V-LCD5.6PRO Kit V-LCD5.6-PRO with battery pack, charger and carrying case (#MAVLC56PROK).....**289.99**

itone

LM-401M / LM-701M

4" / 7" Camera-Mountable LCD Monitors

These professional LCD monitors offer high brightness and extended viewing angles in a rugged metal case. They have two composite video inputs and automatically detect NTSC or PAL standards. AC adapter is included.



- Universal 1/4-20 mount • Image can be reversed or flipped

LM-401M 4" Color LCD (#TVLM401M).....**259.95**

LM-701M 7" Color LCD 16:9 (#TVLM701M).....**449.95**

datavideo

TLM-700 7" Color TFT LCD Monitor

The TLM-700 is the perfect solution for enhanced monitoring in the field or studio. It accepts both NTSC and PAL (16:9/4:3) standard signals, with an auto detect function so that manual switching is never necessary. Front-panel picture adjustment dials are recessed to avoid unintended manipulation. Includes power, sunshade, and accessories.



TLM-700 (#DATLM700).....429.95

GLIDECAM

L4Pro / L5Pro / L7Pro

On-Camera LCD Monitors

L4PRO 4" Active Matrix TFT LCD Monitor

- Mounting bracket • Sunshade
- Power optional

#GLL4P.....**399.95**

Battery Pack & Charger

for L4-PRO LCD Monitor

#GLBPL4P.....**99.95**

L7-PRO 16:9/4:3 Color Monitor

- AC power adapter • Mounting bracket • Monitor hood

#GLL7P.....**649.95**



VariZoom

VZ-TFT7

7" TFT Series Color Monitor

Frame your shots accurately with this 16:9 active matrix color LCD monitor. It has a vivid and sharp 1440 x 234 resolution display.



VZ-TFT7 includes:

AC adapter and A/V cable (#VAVZTFT7).....**278.49**

VZ-TFT7U 7" Ultimate LCD Kit includes: AC adapter, A/V cable, Swivel Shoe Mount, Hood, Battery & Charger (#VAVZTFT7U).**278.49**

Nebtek NEB258 Pro

5.8" Pro LCD Widescreen Monitors

Designed for field monitoring, these 5.8" widescreen LCD screens can flip images both horizontally and vertically. They feature an anti-glare panel—ensuring success in harsh environments—and can be mounted from either top or bottom. 16:9/4:3 switchable.



PROLI Sony Battery Mount (#NENE258PROL).....**842.95**

PROXL Canon Battery Mount (#NENE258PROX).....**842.95**

PROPAN Panasonic Mount (#NENE258PROP).....**829.95**

PROJVC JVC Battery Mount (#NENE258PROJ).....**842.95**

TOTE VISION

LCD-411KIT

4" Field Monitor with BNC

- BNC IN/OUT jacks located on top for easy access
- LED backlight provides longer life, uses less power and provides better color saturation
- Snap on battery pack holds 8 AA Alkaline or 9 Nicad rechargeable batteries (batteries not included)
- Durable ABS plastic case • 5.5 hrs battery operation (approx.)
- Response Time: 30ms/50ms (Rising/Falling).



Kit includes: TB-410 Tote Bag, AC-1000 AC Adapter, AV Adapter Cable and AA Battery Holder (#TOLCD411K).....**359.95**

LCD-801 8" LCD Monitor

This lightweight monitor with professional display characteristics can flip the image to display like a rear-view mirror, or flip the image upside-down as well. Its LCD panel contains 1440 x 468 pixels to display high-quality images, and has a backlight dimmer control for tailoring the look to your ambient lighting conditions. This monitor can be used with NTSC and PAL system, and has an auto detect function.



#TOLCD801.....**522.95**



Manfrotto

8141Q / 8191 / 823

Hydrostatic Mounting Arms

Firmly hold any camera, monitor or accessory with these hydraulic, oil-filled, dual mounting arms that affix to devices with 1/4-20" & 3/8" threads. Securely lock all joints with just a slight turn of the wrist.



814: 5" long, supports loads up to 7.7 lbs (#MA8141Q).....**143.95**

819-1: 7" long, supports loads up to 4.9 lbs (#MA8191).....**143.95**

823: 9" long, supports loads up to 8.8 lbs (#MA823).....**179.95**

386B Nano Clamp: Supports up to 8.8 lbs (#MA386B).....**28.80**



NO-MG6145CA

MG Cine Arm, 3 Locking Joints

The heart of the device is its single central locking knob that simultaneously locks all 3 joints. It's new, improved central mechanism—a kip lever—is designed to quickly and easily lock or release the arm's 3 articulated joints. Redesigned with equal length on both sides of the arm for increased strength and holding resistance.



NO-MG6145CA MG Cine Arm (#NOMG6145CA).....**149.99**



PEARSTONE

4.2- and 8.3-inch Articulating Israeli Arms

Pearstones articulating "Israeli" arms are used to mount small displays on prosumer and professional camcorders. The arm's unique design features a single-point locking mechanism, which gives the user maximum flexibility. Moving the display on multiple axes is quick and easy, allowing users to find the best possible viewing angle.



4.2" Articulating Israeli Arm (PEAA42).....64.95

8.3" Articulating Israeli Arm (PEAA83).....74.95



DM-3105

5" HD/SD LCD Monitor

The DM-3105 is a versatile, lightweight field monitor that supports 21 types of HDTV input signals and two SDTV video formats. It features frame markers, aspect ratio settings, and waveform and vectorscope displays — making it the perfect companion for field productions and mobile video monitoring. For added convenience, there are numerous picture adjustments, as well as audio level metering and selectable color temperatures of 5500K, 6500K, and 9300K.



ASDM3105 **3499.95**

DM-3011

8.4" TFT Professional LCD Monitor

High-quality flat panel monitor designed for monitoring at remote broadcasting and location sites, field monitoring, and studio applications. Displays information such as audio channels, time code, peaking and markers. Virtually all HD format signals are supported through the HD-SDI input. Front switches for brightness, contrast, and chroma make the monitor very easy to control.



#ASDM3011 **6874.95**



HD071A 7.1" HD Pro LCD Monitor

The HD071A is 7.1" widescreen LCD monitor with a bright, high-resolution 1024 x 600 screen that makes focusing on-location a breeze. With its advanced color controls, multiple inputs, anamorphic 16:9 image and 1:1 pixel mapping, it is bigger, sharper, and more versatile than any on-camera LCD screen. Shoot run-and-gun with a video DSLR or loft your rig high on the end of a jib, while framing and focusing your HD images with confidence. Also features image flip (for use with 35mm adapters), NTSC/PAL switchability, and two 1/4"-20 mounting threads. An optional sun hood is also available.



#MAHD071A **589.95**

HD089B 8.9" HD Pro LCD Field Monitor

Bright, fully HD compatible widescreen LCD monitor with a high-resolution 1024 x 600 screen that lets you really see what you're focusing on. With its advanced color controls, multiple inputs, anamorphic 16:9 image and 1:1 pixel mapping. Whether shooting run-and-gun with a video DSLR or lifting your camcorder high on the end of a jib, the HD089B helps you frame and focus your HD images with true confidence--and on a budget you can afford.



#MAHD089B **619.99**
 With Sony Battery Plate #MAHD089BS **744.95**
 With Canon Battery Plate #MAHD089BC **744.95**
 With Panasonic Battery Plate #MAHD089BP **744.95**

Marshall

V-LCD651STX

6.5" Super Transflective On-Camera Monitors

Portable field / on-camera monitor designed for outdoor applications with high ambient light. Marshall's technology minimizes surface reflection of both outdoor and indoor light, while featuring a much wider color reproduction range than typical transflective/reflective LCDs or even those with increased backlight performance. Marshall's outdoor super-transmissive LCDs provide improved visibility by producing high-contrast images and a wider viewing angle, even under diverse and challenging lighting environments. This innovative technology dramatically boosts the efficiency of the LCD backlight's light utilization, while maintaining extended temperature ratings and low power consumption for outdoor operation.



The V-LCD651ST has a durable and lightweight design, weighing only 20 oz. Features a digital TFT-MegaPixel high resolution LCD 1024 x 768 screen with 2.4 million pixels, 4-pin XLR power jack, and optical-grade polycarbonate screen protection. Analog signals are digitized using advanced 10-bit processing with 4x oversampling and adaptive 5-line comb filter.

- 650 cd/m² brightness, 500:1 contrast ratio
- 4 user-configurable function buttons
- RGB gain and bias control
- False Color and Peaking Filter On/Off
- RGB Check Field / Field Detect
- 16:9, 4:3, Pixel-to-Pixel modes • Variety of Markers

Available in three major module configurations:

HDA (Composite, YPbPr)
 HDMI (Composite, YPbPr and HDMI).
 3GSDI (Composite, YPbPr and 3G/HD/SDI)

V-LCD651STX-HDA

Without any battery mount (#MAVL65XH)..... **1544.95**
 With Anton Bauer battery mount (#MAVL65XHABM)..... **1649.95**
 With Canon battery mount (#MAVL65XHCM)..... **1554.95**
 With JVC battery mount (#MAVL65XHJM)..... **1554.95**
 With Panasonic Battery (#MAVL65XHJM)..... **1554.95**
 With Sony B battery mount (#MAVL65XHBSM)..... **1554.95**
 With Sony L battery mount (#MAVL65XHLSM)..... **1554.95**
 With Sony M battery mount (#MAVL65XHSM)..... **1554.95**
 With IDX V battery mount (#MAVL65XHVM)..... **1636.50**

V-LCD651STX-HDMI

Without any battery mount (#MAVL65XHQ)..... **1619.95**
 With Anton Bauer battery mount (#MAVL65XHABMQ)..... **1729.95**
 With Canon battery mount (#MAVL65XHCMQ)..... **1637.50**
 With JVC battery mount (#MAVL65XHJMQ)..... **1637.50**
 With Panasonic Battery (#MAVL65XHJMQ)..... **1637.50**
 With Sony B battery mount (#MAVL65XHBSMQ)..... **1637.50**
 With Sony L battery mount (#MAVL65XHLSMQ)..... **1637.50**
 With Sony M battery mount (#MAVL65XHSMQ)..... **1637.50**
 With IDX V battery mount (#MAVL65XHVMQ)..... **1729.95**

V-LCD651STX-3GSDI

Without any battery mount (#MAVL65X3G)..... **1774.95**
 With Anton Bauer battery mount (#MAVL65X3GABM)..... **1874.95**
 With Canon battery mount (#MAVL65X3GCM)..... **1799.95**
 With JVC battery mount (#MAVL65X3GJM)..... **1739.95**
 With Panasonic Battery (#MAVL65X3GPM)..... **1739.95**
 With Sony B battery mount (#MAVL65X3GSM)..... **1739.95**
 With Sony L battery mount (#MAVL65X3GSLM)..... **Call**
 With Sony M battery mount (#MAVL65X3GSM)..... **1739.95**
 With IDX V battery mount (#MAVL65X3GVM)..... **1828.95**

V-LCD70XP

7" Portable Field /On-Camera LCD Monitors

The V-LCD70XP is the perfect solution for video professionals seeking to capture their best shots. Standard features include a wide variety of formats and markers, 4 user configurable front panel function buttons, RGB



Check Field / Field Detect, RGB gain and bias control, 4-pin XLR power jack, and optical grade polycarbonate screen protection. Other features include Marshall's industry leading FALSE COLOR and PEAKING Filter, cast metal front panel, adjustable backlight and markers, manual gamma adjustment, Image Flip, 1/4"-20 mounting on all sides, and a more robust power switch.

- High resolution 800 x 480 LCD panel
- Manual Gamma Adjustment
- Adjustable Backlight
- Image Flip
- 1/4"-20 mounts on all sides
- Robust Power switch and rugged front panel
- Variety of Markers, including user-adjustable
- False Color and Peaking Filter On/Off
- RGB Check Field / Field Detect
- 15:9, 16:9, 4:3, Pixel-to-Pixel modes
- Scratch Resistant Protective Screen
- 4 user-configurable function buttons
- RGB gain and bias control

Available in three major module configurations:

HDA (Composite, YPbPr)
 HDMI (Composite, YPbPr and HDMI).
 3GSDI (Composite, YPbPr and 3G/HD/SDI)

V-LCD70XP-HDA

Without any battery mount **Call or Log-on**
 With Anton Bauer battery mount (#MAVL70XPBHQ)..... **898.99**
 With Canon battery mount (#MAVL70XPBHQ)..... **859.95**
 With JVC battery mount (#MAVL70XPBJMQ)..... **859.95**
 With Panasonic Battery (#MAVL70XPBJMQ)..... **859.95**
 With Sony B battery mount (#MAVL70XPBBS)..... **859.95**
 With Sony L battery mount (#MAVL70XPBLS)..... **859.95**
 With Sony M battery mount (#MAVL70XPBMS)..... **859.95**
 With IDX V battery mount (#MAVL70XPBVM)..... **898.99**

V-LCD70XP-HDMI

Without any battery mount (#MAVLCD70XP)..... **880.29**
 With Anton Bauer battery mount (#MAVL70XPB)..... **987.89**
 With Canon battery mount (#MAVL70XPB)..... **904.99**
 With JVC battery mount **Call or Log-on**
 With Panasonic Battery (#MAVL70XPB)..... **902.89**
 With Sony B battery mount (#MAVL70XPBBS)..... **902.89**
 With Sony L battery mount (#MAVL70XPBLS)..... **902.89**
 With Sony M battery mount (#MAVL70XPBMS)..... **902.89**
 With IDX V battery mount (#MAVL65HIM)..... **Call**

V-LCD70XP-3GSDI

Without any battery mount (#MAVLCD70XP3G)..... **1049.95**
 With Anton Bauer battery mount (#MAVL70XP3GAB)..... **1122.69**
 With Canon battery mount..... **Call or Log-on**
 With JVC battery mount **Call or Log-on**
 With Panasonic Battery (#MAVL70XP3GPM)..... **1044.09**
 With Sony B battery mount (#MAVL70XP3GSM)..... **1044.09**
 With Sony L battery mount (#MAVL70XP3GSL)..... **1044.09**
 With Sony M battery mount (#MAVL70XP3GSM)..... **1094.95**
 With IDX V battery mount (#MAVL70XP3GVM)..... **1122.69**

Marshall

V-LCD65SB-HDA

6.5" LCD Monitor with Analog HD/SD Inputs

Designed specifically for outdoor applications, the high resolution V-LCD65SB-HDA incorporates proprietary SunBrite technology to boost the efficiency of the backlight's light utilization while minimizing the surface reflection of ambient light. Inputs include composite with NTSC/PAL auto recognition and HD/SD analog component via multi-format connector (BNC x3). Also features 16:9/4:3 aspect ratio, image flip, RGB calibration and safe area. Includes V-Mount battery adapter. (#MAVLCD65SBHD) **1499.95**



V-LCD8-PRO

7.9" High Resolution LCD Monitor



The lightweight (1.7 lbs.) but high resolution (1440 x234) V-LCD8-PRO has a sleek design that makes it ideal for any indoor or outdoor monitoring application. It features composite and S-Video input

with NTSC/PAL auto recognition and loop through capability. Equipped with 1/4-20 mount and a bayonet locking 12v DC power supply that ensures that the power won't be disconnected while being handled. An on-screen display lets you access color, tint, contrast and brightness controls.

MAVLCD8PRO **688.99**

OR-841 'Orchid'

8.4" Rack Mountable / On-Camera Portable Field Monitor

The OR-841 can be used in a rack (4RU), on a desktop, in the field, or mounted to a camera. It has 9 user-assignable function keys as well as a rotary menu system.



The built-in waveform monitor (which includes adjustable White and Black clip level indicators) can be displayed in three different aspect ratios including Full Screen. The built-in vectorscope displays in full color and can also be displayed in three different ratios. The vectorscope has adjustable gain from 1x to 5x. The OR-841 will also de-embed and display up to 16 channels of audio and allow users to monitor any two channels at once through the headphone jack or rear line output jack. Also includes built-in front panel speaker and rear panel stereo input for audio monitoring. The 64-segment tri-color bar graph meters have user-adjustable reference levels.

- Auto White Balance Calibration
- Tri-Color Tally Indicator • On-Screen Time Code
- 7 assignable GPI inputs • Adjustable Color Temperature
- Adjustable Clipping Indicator • Precision Gamma Settings
- Variety of Safety Markers • Support 3 different battery adapters
- Factory-installed Protective Screen

OR-841: With component, S-Video and auto-sensing HDS/SDI inputs and re-clocked output (#MAOR841) **3369.95**

OR-841-HDS/SDI: With auto-sensing HDS/SDI inputs and re-clocked output only (#MAOR841HDS/SDI) **2999.95**

Marshall

V-R70P

7" Stand alone / Video Assist Monitor

The V-R70P series feature completely Digital TFT-MegaPixel (800 x 400) high resolution widescreen LCD with 1.2 million pixels in a durable metal enclosure. They offer a V-Mount battery adapter (run 4 to 6 hours on optional 50WH battery), 4-pin XLR power jack, and optical-grade polycarbonate screen cover with anti-reflective/anti-glare coating.



- 380 candelas per square meter (cd/m²) luminance produces enhanced image quality in varying light and viewing conditions
- 400:1 contrast ratio • 4:3 and 16:9 screen aspect ratios
- Automatic NTSC/PAL format detection
- Easy-to-see three color tally indicators
- Built-in Color Bars and Blue Screen for color adjustment
- Adjustment Settings Memory
- Includes universal voltage Class-2 power supply

V-R70P-SD: SDI input/output, composite and S-Video input and loop output (#MAVR70P/SD) **1178.89**

V-R70P-HDA: Composite (NTSC/PAL), S-Video and component (YPbPr) HD/SD input with loop-out (#MAVR70P/HDA) **1234.99**

V-R70P-HDA-AB: Same as above with Anton Bauer Battery Mount (#MAVR70P/HDA/AB) **1389.95**

V-R70P-HDS/SDI: HDS/SDI I/O only (#MAVR70P/HDS/SDI) **1549.95**

V-R70P-HDS/SDI-AB: Same as above with Anton Bauer Battery Mount (#MAVR70P/HDS/SDI/AB) **1694.95**

Nebtek NEB70HD

7" Analog Onboard Camera Monitor

The New NEB70HD is a 7" Widescreen HD-Analog LCD On-Board Camera Monitor. It offers your choice of 16:9, 4:3, Zoom, Pixel, Anamorphic, and Marker Display modes.



Both durable and portable, it is a perfect choice for HD camera operators working in the studio or under rugged field conditions.

- NTSC/PAL Auto-Recognition

NEB70HD 7" Analog Monitor (#NENE70HD) **1399.95**

Panasonic

BT-LH80WU / LH900A

Professional LCD Monitors



These multi-format color production LCD monitors are designed for high-definition field monitoring. Handles all HDTV formats and frame rates (NTSC/PAL), and can be customized to switch between

them automatically. The display features pixel-to-pixel and focus-in-red functions. Displays the input signal as a waveform image.

- Powered via Anton-Bauer batteries or 4-pin XLR

BT-LH80WU 7.9" LCD monitor (#PABTLH80WU) **Call**

BT-LH900A 8.4" LCD monitor with two SDI inputs detecting HD or SD (#PABTLH900A) **Call**

SONY LMD-940W

9" WVGA ENG/EFP LCD with 3G SDI Capability

The high-grade LMD-940W incorporates 3G SDI capability allowing it to accept 50P and 60P video signals using a single SDI cable. It employs a 800 x 480 (WVGA) LCD panel with high brightness, contrast, and fast response to offer excellent color reproduction even in outdoor or bright ambient light. Sony's ChromaTru Color Processing lets it accurately depict SMPTE, EBU and ITU color standards. Has composite and auto-detect HDS/SDI/3G SDI I/O and HDMI input. #SOLMD940W **Call or Log-on**



TOTE VISION

LCD-703HD / LCD-703HD-KIT

7" LCD Field Monitor

A 7" LCD designed to work with a variety of inputs, including component, S-video, and DVI. The display also supports RS-232 through its serial port, allowing users to attach



external remote control devices. Features such as NTSC/PAL auto-detection, underscan, and anti-glare technology make the LCD-703HD a perfect choice for a wide variety of applications.

LCD-703HD 7" LCD Field Monitor (#TOLCD703HD) **579.95**

LCD-703HD-KIT 7" Monitor Kit (#TOLCD703HDKIT) **719.95**

transvideo

Videofinder 5.8VF 5.8" TFT LCD Monitor

This high-quality 5.8" video LCD has easy-to-use image adjustment knobs along with a backlight dimmer to adapt to lighting situations. It has a durable compound casing with tempered glass that protects the unit during extreme field conditions. It can be powered by XLR-4 or Hirose 6 connectors, and will accept 8.5 to 18V DC (optional). (#TR58VM) **1049.95**



CineMonitor HD6SBL Super Bright

6" High-Definition LCD monitor



Designed for use in professional video applications, the monitor features a super-bright LED backlight that produces 1000 Nits of brightness, allowing you to work with an unobstructed view even in full sunlight. Use this unit in digital cinematography, high-speed digital video, Steadicam work, helicopter setups (SB versions), harsh working environment, or any other similar application. It accepts all SDI and analog SD & HD video signals. Aspect ratio is selectable among 16:9, 4:3, and anamorphic. Includes a luminance waveform monitor and a tally light.

#TR6CMHDSB **5694.95**

V-3800

3.8" SD LCD Monitor with Speakers

Standard Definition LCD Monitor is small enough to fit just about anywhere. It's also light, weighing only half a pound, and extremely affordable. The built-in stereo speakers and AV input make it especially convenient for playing back footage for all to see and hear. • Threaded 1/4-20 Mount • Composite Input



V-3800 SD LCD Monitor (#IKV3800).....**99.95**



V-7000

7" High Resolution TFT LCD Monitor

Lightweight, versatile LCD monitor meet the many demands of 16:9 field viewing; picture can be flipped both horizontally and vertically, display resolution is 1440 x 234, and they switchable between NTSC and PAL. Includes shoe mount, table stand, power adapters, remote control



V-7000 LCD Monitor (#IKV7000).....**Call or Log-on**



V-5600 HDMI

High-Definition 5.6" TFT LCD Monitor

Features HDMI, YUV, and AV inputs. The monitor is ideal for pairing with both video-enabled DSLRs as well as compact prosumer camcorders. Its high resolution panel allows users to verify focus while still being compact enough to take virtually anywhere. • High Definition & Standard Definition



- HDMI, Component, & Composite Inputs
- Color System NTSC & PAL • 480i, 480p, 720p, 1080i
- Safe area guides for 16:9 and 4:3 aspect ratios

V-5600 LCD Monitor (#IKV5600).....**629.99**

V-56600 Deluxe Kits w/ Case, Battery, Charger and Adapter Kit for Canon 900 Series Batteries (#IKV5600DKC).....793.99

Kit for Sony Batteries (#IKV5600DKS).....749.95

Kit for Panasonic D54 Seires Batteries (#IKV5600DKP).....689.09



V-8000HDMI

High-Definition 8" TFT LCD Monitor

Supports 480p, 720p, and 1080i. Its native 800 x 480 display interpolates to 1080i and is NTSC/PAL switchable. Connections include component HD, S-Video, composite with pass-through and HDMI. Powered via the camcorder batteries, which can be charged by the supplied AC adapter. On-camera mount also included.



With Sony Battery Plate (#IKV8000HDMSS).....**731.39**

With Canon Battery Plate (#IKV8000HDMC).....**729.95**

With Panasonic Battery Plate (#IKV8000HDMPP).....**731.39**

V-8000 HDMI Deluxe Kits with Monitor, Battery, Charger, Camera Shoe Mount, AC Adapter and Case

Monitor Deluxe Kit for Canon (#IKV8HDMICDK).....**819.99**

Monitor Deluxe Kit for Panasonic (#IKV8HDMISDK).....**819.99**

Monitor Deluxe Kit for Panasonic (#IKV8HDMIPDK).....**819.99**



VX7 7" HD-SDI LCD Monitor

High-quality HD/SD production monitor that combines light weight and affordability with a range of professional inputs and features. Equipped with a battery plate to use already existing camera batteries, the VX7 provides intuitive control with 1024 x 600 image quality to keep your images sharp, perfectly framed, and always in focus.



- 1024 x 600 • 400:1 Contrast Ratio
- HD-SDI, HDMI, Component, Composite • LED Backlighting
- Overscan/Underscan • Shoe Mount

VX7-C LCD Monitor w/Canon Battery Plate (#IKVX7C).....**999.00**

VX7-P LCD Monitor w/Panasonic Battery Plate (#IKVX7P).....**999.95**

VX7-SU LCD Monitor w/Sony 'BP-U' Battery (#IKVX7SU).....**999.00**

VX7-S LCD Monitor w/Sony 'L' Battery Plate (#IKVX7S).....**999.00**

VX7 Deluxe Kit Includes: Monitor, AC Adapter, Camera Shoe Mount, Battery Plate, DV Battery, Charger and Metal Case

VX7-C-DK Deluxe Kit for Canon (#IKVX7CDK).....**1129.95**

VX7-S-DK Deluxe Kit for Sony (#IKVX7SDK).....**1124.95**

VX7-P-DK Deluxe Kit for Panasonic (#IKVX7PDK).....**1129.95**

VG7 7" SD-VGA LCD Monitor

Compact standard-definition monitor offers 800 x 480 resolution and a level of portability and mounts easily to your camera using the included 1/4"-20 shoe mount. Switch between 4:3 and 16:9 aspect ratios, accepting input over one of two composite cables or from your PC via a VGA cable. Great as a backup monitor or a second computer display. The VG7 can be purchased with an optional battery plate for use with other camcorder batteries.



VG7 LCD Monitor without Battery (#IKVG7).....**324.95**

VG7-C LCD Monitor w/Canon Battery Plate (#IKVG7DKC).....**459.95**

VG7-P LCD Monitor w/Panasonic Batt. Plate (#IKVG7DKP).....**459.95**

VG7-S LCD Monitor w/Sony Battery Plate (#IKVG7DKS).....**459.95**

VX9 8.9" HD-SDI LCD Monitor

Brings Industry-standard HD-SDI input to Ikan's line of affordable on-camera production monitors. With its sleek, high-resolution 1024 x 600 display, NTSC/PAL capability, wide range of aspect ratios, this monitor can truly roll with the big boys.



- Comes with a Battery Plate, so you can easily power it with the same DV batteries used by your camcorder.
- HDMI, Component, Composite, HD-SDI, SVHS
- Blue Gun, Pixel to Pixel, Underscan, Overscan
- 1/4-20 threaded mounting holes on all four sides
- Aspect ratios: 480i/p, 576i, 720p, 1080i/p

VX9-C LCD Monitor w/Canon Battery Plate (#IKVX9C).....**1088.95**

VX9-P LCD Monitor w/Panasonic Battery Plate (#IKVX9P).....**1089.00**

VX9-S LCD Monitor w/Sony Battery Plate (#IKVX9S).....**1089.95**

VX9 Deluxe Kit Includes: Monitor, AC Adapter, 6" Articulating Arm, Battery Plate, DV Battery, Charger and Hard Case

VX9-C-DK Deluxe Kit for Canon (#IKVX9CDK).....**1199.95**

VX9-S-DK Deluxe Kit for Sony (#IKVX9SDK).....**1199.95**

VX9-P-DK Deluxe Kit for Panasonic (#IKVX9PDK).....**1199.95**



CRVD 43" Curved Display

The world's first curved desktop monitor, the CRVD is like having 2 monitors in 1, its 2880 x 900 resolution providing new levels of ergonomic comfort and an unprecedented aspect ratio of 32:10--or 180% wider than standard 16:9 displays.



All on-screen images are simulated pictures

- First Curved Desktop Monitor • Like 2 Monitors In 1
- 2880 x 900 Resolution • 32:10 Aspect Ratio
- 10,000:1 Contrast Ratio • Bright LED Color
- Ultra Fast Response Time • 68.7 Billion Colors
- Works with Current Graphics Cards

CDM43 43" Curved Display (#OSCDM43).....**1699.95**

Marshall

M-LCD7-HDMI

7" Portable On-Camera Field Monitors

Completely portable answer to the need for accurate focusing when shooting video with DSLR cameras or camcorders with small LCD screens. The M-LCD7-HDMI not only gives you a large, bright 800 x 480 display to focus on, it provides inputs for both HD and standard-def video as well as the flexibility of being able to use your camera's existing batteries for power.



- 7" TFT LCD display attaches directly to DSLR or DV cameras
- HDMI input works with the latest HD video cameras and high-performance digital SLR cameras
- A must-have tool for photographers and videographers
- AV input compatible with most digital cameras
- Includes table stand, AC power and lighter adapter

M-LCD7-HDMI 7" with AC (#MAMLCD7HB01).....**294.95**

M-LCD7-HDMI-C511 7" with Canon BP511 Battery (#MAMLCD7HBC51).....**394.95**

M-LCD7-HDMI-CE6 7" with Canon LP-E6 Battery (#MAMLCD7HBC6).....**399.95**

M-LCD7-HDMI-NEL3 7" with Nikon EN-EL3e Battery (#MAMLCD7HBNEL).....**394.95**



TLM-700HD

7" Wide Screen SDI / HDMI LCD Monitor

7" Monitor with a range of both High and standard definition connections including HD & SD-SDI, HD & SD YUV, HDMI & Composite Video Inputs. The range of connections and rugged metal design make it a perfect choice for users who work outdoors in the field or in a studio, with HD or SD.

- Resolution: RGB 800 x 480 dots • Brightness, Contrast, Color, Tint Adjustable
- Flip/Mirror effect • NTSC/PAL Auto Switching

TLM-700HD 7" SD/HD Monitor (#DATLM700HD).....**960.00**

TLM-700HDK 7" with Battery & Bag (#DATLM700HDK) ...**1329.95**



TLM-702 / 702MH / 433 / 404H
Color LCD Monitor Racks

Designed for DataVideo mixers, these monitor rack panels can also be used in other rack systems.

- NTSC & PAL • 16:9/4:3 display

- TLM-702** Dual 7" LCD monitor rack (#DATLM702).....**799.95**
- 702HD** Dual 7" LCD Monitor Rack (#DATLM702HD).....**1799.95**
- 702MH** Dual 7" /RKM-772 holder mt. (#DATLM702MH).....**939.95**
- 433** Three 5" color LCD monitor rack (#DATLM433).....**949.95**
- 404H** Quad 4" color LCD monitor bank (#DATLM404H).....**1199.95**



LM-563R • LM-404R • LM-404HD
Rackmount Multi-LCD Monitors

The LM-563R and LM-404R are high performance color LCD monitors in unique rackmount housings that tilt up or down to optimize the viewing angle. This is particularly beneficial when circumstances necessitate that the monitors be mounted above or below normal eye level. Each feature high brightness, active matrix LCD displays with wide viewing angles and excellent contrast ratios. They are flicker-free, low radiation, light weight, space saving and feature low power consumption.

- LM-404R:** Quad 4-inch monitors (#TVM404R).....**1269.95**
- LM-563R:** Triple 5.6-inch monitors (#TVM563R).....**1499.95**
- LM-404HD:** Quad 4.3-inch HDTV (#TVM404HD).....**4089.95**

LM-503HD / LM-702HD / LM-1750HD
5" / 7" / 17" Rackmount LCD HD Monitors



Rackmount HDTV monitors with a wide array of inputs (including SDI, RGB, component, and composite) and NTSC/PAL capability. Resolutions up to 1080p (video) and 1024 x 768 (LM-503HD)

- 16:9 • 600:1 Contrast Ratio • NTSC/PAL • SD/HD-SDI
- Includes Tilting Rack Mount Kit • Tally LEDs • Adjustable Angle

- LM-503HD** Triple 5" HDTV Monitors (#TVM503HD).....**3499.95**
- LM-702HD** Dual 7" HDTV Monitors, (#TVM702HD).....**2999.95**
- LM-1750HD** 17" HDTV Monitor, (#TVM1750HD).....**3079.95**

Marshall

V-R171-IMD-HDSDI / V-R201 / V-R231 / V-R261
HD LCD IMD Series Monitors

The V-R171-IMD-HDSDI is a 17" 16:9 LCD featuring 1920 x 1200 resolution. The monitor is large enough to function as a desktop unit, or it can be installed in a racking system using a VESA mount bracket. Unique protocol feature can handle Image Video, NVISION, TSL, and MEI standards. Image quality is preserved over the SD/HD gamut using sophisticated scaling technology.



- V-R171-IMD-HDSDI** 17" (#MAVR171IMDHD).....**1774.95**
- V-R201-IMD-HDSDI** 20" (#MAVR201IMDHD).....**Call or Log-on**
- V-R231-IMD-HDSDI** 23" (#MAVR231IMDHD).....**2189.95**
- V-R261-IMD-HDSDI** 26" (#MAVR261IMDHD).....**2599.95**
- V-R371-IMD-HDSDI** 37" LCD (#MAVR371IMDHD).....**2849.95**



V-R902DP-TE / AFD

9" Dual LCD Monitor Rackmounts

This pair of 9" high-resolution LCD monitors is housed in a compact rack that conserves space and power. Automatically detects NTSC and PAL signals.

- 800 x 480 resolution (2x)
- 130-degree viewing angle • HD/SD-SDI and BNC inputs
- V-R902DP-TE** (#MAVR902DPTE).....**3666.50**
- V-R902DP-AFD** 9" dual rack-mount monitors w/ HD/SD-SDI, composite, S-video, SXGA inputs (#MAVR902DPAFH).....**3949.95**



V-R653-IMD-TE Triple 6.5" HD Rack LCD Monitor with IMD Functionality

This is a cost-effective, all-in-one solution for post-production houses, broadcasters and mobile units.

- High-resolution 1024 x 768 with 2.4 million pixels
- Unique RotoMenu for fast, direct and easy menu navigation
- High-resolution scaling/de-interlacing • RS-422 connection with loop-through • Upgradeable firmware capability via RS-422 • Built-in color bars, brightness and contrast
- #MAVR653IMD**.....**4349.95**

V-R82DP-2C / SDI / DP-HD
8.4" Dual Rack-Mount LCD Monitors

TFT-Megapixel technology ensures that multi-format scaled images never distort. Hyper Process technology smooths out interlaced signals.



- Dual 8.4" LCDs
- 800 x 600 resolution (2x)
- NTSC/PAL autoswitch • Color, brightness, contrast, and tint
- V-R82DP-2C** Dual 8.4" LCD's (#MAVR82DP2C).....**1649.95**
- V-R82DP-2SDI** 8.4" LCD's (#MAVR82DP2SDI).....**2599.95**
- V-R82DP-HD** Dual 8.4" LCD's (#MAVR82DPHD).....**3374.99**
- V-R1042-IMD-TE4U** Dual 10.4" (#MA1042PIMDT).....**3479.95**



V-R53P Triple 5" LCD Panel

The Marshall V-R53P is a rack-mountable active matrix LCD unit with three 5" LCD panels built in. Once rack-mounted, the entire unit can tilt up or down for optimal viewing. With low power consumption and heat dissipation features built in, the V-R53P is an excellent choice for remote vehicle applications.

- 320 x 234 pixel resolution (x3) • Composite and RGB inputs
- Contrast, color, brightness, and tint controls
- V-R53P** (#MAVR53P).....**1799.95**
- V-R53P-SDI** Triple 5" monitors with SDI/composite/VGA inputs (#MAVR53PSDI).....**2677.50**



V-R44P / SDI / DVI / HDSDI
Quad 4" LCD Rack Mountable Monitors

Four separate monitors display high-quality images, each with a resolution of 480 x 234 pixels. Each monitor can auto-detect NTSC and PAL signals, while a dry erase marking area can be used to identify camera angles or programs.

- Composite video inputs and outputs (BNC)
- Contrast, color, brightness, and tint controls
- V-R44P** Quad 4" rack-mount monitors (#MAVR44P).....**1224.95**
- V-R44P-DVI** Quad 3.5" w/DVI (#MAVR44PDVI).....**2899.95**
- V-R44P-HDSDI** Quad 4" rack-mount monitors with SD/HD-SDI inputs (#MAVR44PHDSDI).....**3199.95**

RM8000 Metal Rack Mount Unit with Dual V8000 8" Monitors

The RM8000 from Ikan is a tilting rack mount which houses dual V8000 8" monitors. The Ikan V-8000T is a small, high-resolution video monitor with a touch-sensitive LCD panel. This model can be used for displaying computer images as well as video input. The touch-screen function makes the V-8000T applicable to interactive kiosks. Includes two standard video inputs—one can function as a high-quality S-video connection. The monitor comes with a wireless infrared remote control to switch among input sources and to access the on-screen menu.



- Metal rack mount unit** with dual V8000 8" monitors (#IKRM8000).....**899.95**
- Metal rack unit** with dual V8000HDMI 8" monitors (#IKRM8000HDMI).....**1659.95**



TLM-170 / D / M / MD 17" Desktop LCD Screen Monitors

The TLM-170 monitors are 17" 16:9 aspect ratio, 1440 x 900 high resolution monitors with built-in speakers. This is a fixed version (tabletop). High quality reference monitors designed to assist as a program monitoring output during production.

- 17" Reference Monitor • Multiple Video Formats

- TLM-170** 17" LCD Screen Monitor (#DATLM170).....**1439.95**
- TLM-170D** 17" Monitor with HD-SDI (#DATLM170D).....**1699.95**
- TLM-170M** 17" Auto detect format (#DATLM170M).....**1699.95**
- TLM-170MD** 17" Multi Format monitor, with HD-SDI format support (#DATLM170MD).....**1699.95**





DAC-7 Analog to SDI Converter

The DAC-7 is a small, extremely portable but powerful mini converter that enables users to convert the output from any camera, including prosumer level cameras, to professional SD-SDI for connection to professional or broadcast equipment. Converts component, composite, and S-video input to SD-SDI video output. Audio inputs include balanced XLR and unbalanced RCA. Also has an RS-232 port. Unique design allows it to be mounted between the camera and a tripod.



DAC-7 (#DADAC7).....399.95
DAC-7L Without Tripod Mounting (#DADAC7L).....384.00

DAC-8 HD/SD-SDI to HDMI Converter

The DAC-8 makes it easy to output uncompressed SDI video and audio to a video projector or HDTV. Two BNC connectors receive the HD/SD-SDI video, while two unbalanced RCA connectors handle the audio—all of which is converted to HDMI and output to your display. This is an ideal, affordable solution for using SDI coaxial cable to transmit high-quality HD video over distances up to 300-ft. In combination with the DAC-9 HDMI to HD/SD-SDI converter, system installers now have an affordable solution for distributing HDMI signal over long distances, without quality compromises.



#DADAC8.....374.95

DAC-9 HDMI to SDI Converter

The DAC-9 makes it easy to use small DV/HDV cameras with HDMI output that are available for live production by converting their HDMI output to SD-SDI or HD-SDI. The DAC-9 converts HDMI to HD-SDI or SD-SDI by autosensing the HDMI input and converting it to the same image size as SD-SDI or HD-SDI. This enables signals from DV or HDV cameras to be used with SDI switchers. In cable runs of 100-200 feet there is a cost advantage in using a long SDI or HD-SDI cable, rather than a long HDMI cable. Self-adhesive straps on the back of the converter make it easy to attach to a tripod leg. A power adapter is included.



#DADAC9.....374.95

DAC-50

HD/SD-SDI to Component/Composite Video Signal Converter

The DAC-50 is a HD/SD-SDI to Y:U:V component and composite video signal converter with built in up/down scaling. The built-in scaler allows users to convert from a HD-SDI (1080i & 720p) or SD-SDI signals to HD (1080i & 720p) or SD (480i/50i) Y:U:V component or composite video signal. The DAC-50 can also cross convert from 1080i to 720p.

Housed in a rugged metal frame, making it durable enough to endure even the roughest conditions.



#DADAC50.....474.95

DN-60 DV/HDV Solid State CF Card Recorder

Portable and shockproof, the DN-60 utilizes the latest technology of removable and high capacity CF memory cards to provide hours of continuous DV, HDV, DVC Pro 25 & 50 standard- and high definition recordings. Tripod and hot shoe mountable, it connects directly to DV or HDV camcorders via single Firewire cable. Features an 8 second pre-record buffer, useful in recording unexpected events especially in outdoor recording or security applications. Built-in intervalometer for time lapse recording. Runs on four AA batteries for more than two hours continuous recording or use the included external power adapter



#DADN60.....479.95

DN-200 HD / SD HDD Recorder

Small portable recorder capable of very long record times. A built-in 250GB hard drive (HDD) stores the video. It can record a minimum of 19 hours depending of the format, DV or HD or HDV. Drag and Drop the video files directly in the time-line of your video editing program. Features comprehensive back-lit LCD display for recording status, an 8 second pre-record buffer; and built-in intervalometer for time lapse recording. Also offers manually triggered single frame recording, and play last video feature. Works on 12v DC or local power.



#DADN200.....Call or Log-on

DN-300 DV & HDV Recorder

An instant on, "drag-and-drop" DV/HDV hard drive recorder, the DN-300 accepts DV and HDV (via Firewire), component (YUV), composite and S-Video inputs. Includes a 250GB hard drive for over 19 hours of video. VTR-style controls with large, illuminated buttons and a two-line backlit LCD display let users select play, REW, Ffast reverse, pause, frame advance, file selection and file delete and loop play. Other features include seamless repeat loop play (for trade shows), variable speed forward or reverse play and frame by frame playback in forward and reverse.



DN-300 (#DADN300).....1194.95
DN-300UPG Upgrade Kit f with removable hard-drive enclosure (#DADN300UPG).....272.95

DN-400 Hard Drive Recorder with Removable Hard Drive

The DN-400 allows for file-based tapeless solutions that save you hours of capturing time. Records standard or high definition from component, composite, S-Video or Firewire. The DN-400 comes with a 250GB removable hard drive installed inside an enclosure (additional enclosures/hard drives are available). Once you have completed your recording, simply eject the hard drive enclosure, and use the USB 2.0 port to connect to a PC or Mac based NLE system, (no power supply required, as USB provides power). You can work directly from the removable drive, or copy video files to your NLE's video drives.



#DADN400.....Call or Log-on

DN-500

Rackmountable DV/HDV Hard Drive Recorder

Take advantage of tapeless acquisition in even the roughest conditions by recording in DV and HDV. Records DV from either digital or analog inputs via component, composite, S-Video, or FireWire input. Records HDV via FireWire input. Enjoy confident native DV and HDV recording while monitoring on a standard video monitor. Once you have completed your recording simply eject the harddrive carrier, for easy connection via USB connector to your NLE system - it is as easy as that!



DADN500.....1744.95

HDR-40 HD/SD SDI HDD Recorder

Designed for studio desktop applications, the HDR-40 records from SD and HD video equipment via SDI, with HDMI output, and convenient SDI loop through. Offers a choice of 1080i, 720p, 576i and 480i recording formats. Record HD in either IBP or Intra-frame (i frame), and SD in IBP. When recording is completed, the hard drive enclosure simply ejects and can connect via USB 2.0 to a PC or Mac-based NLE system. Work directly from the removable drive, or copy video files into the NLE's video drives. Includes RS-422, RS-232, and GPI for easy integration with other equipment.



HDR-40 #DAHDR40.....1899.95
HDR-50 Same as above in rackmount.....1894.95

800-947-1175 | 212-444-6675 Quick Dial: 821

Hard Disk Recorders / Wireless Video Transmission



RFX-NLL-II License-Free Link

The RFX-NLL-II is a state-of-the-art 5.8GHz license

free, digital broadcast microwave audio/video link. The transmitter is designed to mount between an ENG camera and battery. The receiver is designed to be mounted on a tripod or other suitable location. The NLL-II offers a 1500' range, with switchable mic/line inputs, balanced audio, in and out, and microphone phantom power. Video is encoded to MPEG-2, making it ideal for high quality broadcasting environments. Applications include sports arenas, roof top to roof top, and camera to ENG truck.



RFXNLLII **9949.95**



CW-5HD Cam-Wave
HD Wireless Video Transmission System

Transmit HD 1080 and 720 signals wirelessly up to 100 feet (30m) through walls, and up to 150 feet (50m) in line-of-sight, with a transmission delay of less than 1ms. This uncompressed wireless transmitter and receiver system supports both HD-SDI and SD-SDI video signal processing, multiple video formats, and two channels of SDI embedded audio. Wireless transmission operates via MIMO/OFDM, between 5.1-5.8 GHz frequencies—no special FCC license required. It has no visible antenna array, and is powered (10-17v DC) through its V-mount or via 4-pin XLR. Selection of four manual or auto-select frequencies with 256-bit encryption.



CW-5HD Set (DCW5HD) **5599.95**
CW-5HD Set w/Anton Bauer Bracket (DCW5HDAB) **5899.95**



Titan Tx/Rx Microwave Wireless Transmitter & Receiver System

This multi-directional, microwave wireless video transmitter/receiver set can broadcast through walls without desynchronization of the video picture. The Titan Tx/Rx system has a 1,000 ft (300 m) line of sight, a 2.4 GHz frequency range, 4 preset channels, and is FCC, IC and CE certified. Transmits/receives NTSC, PAL & SECAM color and B&W signals. Requires camera-specific power cable, as listed below. Both the Titan transmitter and receiver require a minimum 9V of power, up to 36V, available in a variety of connection options (12V and 14V sources supply ample power in the field). Extremely compact, both units are easily velcroed to any camera or monitor.

- Signals remain stable even when in motion
- Can be used in conjunction with any monitor
- Connectivity via BNC (video), Lemo2 (power) and Hirose 6-pin (video and power)
- 4 channels are pre-dialed and accessible with the flip of a switch—no tools required
- Optional "5MDBP" battery pack adapters allow use of 7.2V cam batteries



95TITANSET Titan Wireless Transmitter Set
Transmitter/Receiver (TRTTS) **2749.95**
Titan Wireless Video Duo Set 1
Trans/Dual Receivers (TRTDS) **3994.95**

Titan Wireless Set for Canon:
Includes Titan Wireless Transmitter Set, Canon Smart Mini DV battery pack, Power only cable, Knee joint with shoe adapter and AL-15 power supply. (TRTTSC) **3099.95**

Titan Wireless Set for Panasonic:
Includes Titan Wireless Transmitter Set, Panasonic Smart Mini DV battery pack, Power only cable, Knee joint with shoe adapter and AL-15 power supply. (TRTTSPK) **3099.95**

Titan Wireless Set for Sony:
Includes Titan Wireless Transmitter Set, Sony Smart Mini DV battery pack, Power only cable, Knee joint with shoe adapter and AL-15 power supply. (TRTTSSK) **3099.95**



FS-H200 • FS-H200 Pro
Portable Hard Drive Recorders

The FS-H200 is a portable DTE (direct-to-edit) recorder that captures SD and HD video to Compact Flash cards. The recorder supports both DV and native HDV acquisition in a variety of resolutions and has the ability to record over 2.5 hours of footage to a 32GB card. By simply swapping in a fresh card when one is full, users can shoot the whole day without having to offload. Just shoot, connect, and edit—no more tape to log and capture, your clips are ready when you are. When used with 25Mbps HDV cameras, the FS-H200 supports QuickTime 1080i50/60 and 720p25/30 recording for Final Cut Pro use as well as M2T 720p/1080i recording for use in a number of different applications from Adobe, Avid and Grass Valley (Canopus). Otherwise the same, the FS-H200 Pro steps up with clip thumbnail viewing, proxy content playback, MPEG4 proxy clips, FTP support and wired/wireless custom metadata logging, DV/HDV MXF support, user-definable 10-second retro cache, and lower power consumption.



FS-H200 (FOFSH200Q) **849.00**
FS-H200 Pro (FOFSH200PQ) **1099.00**



DSLR-PRO Camera Shoulder Support

Shoulder support system designed for use with DSLR cameras. The unit is intended to stabilize DSLR cameras capable of shooting HD video, such as the Canon EOS 5D MKII and EOS 7D, and Panasonic Lumix Series. Constructed from machined aircraft aluminum for durability. An elevated platform ensures that the DSLR viewfinder is raised to eye level. A short slide channel is included to allow for wide-angle shots without visual interference. Three-axis movement allows for extreme mobility when positioning your shots.



DSLR-PRO Camera Shoulder Support (SWDSLPRO) **259.95**
DSLR-PRO/C Camera Shoulder Support with Series 7 Battery Mount (SWDSLPROC) **294.95**
DSLR-PRO/V Camera Shoulder Support with V-Mount for XP-DSLR (SWDSLPROV) **329.95**

FLEX DSLR Remote

Handle-mounted DSLR remote that triggers HD video start and stop recording for Canon EOS 5D MKII and EOS 7D digital cameras. The FLEX's unique gooseneck arm houses an optic that is to be positioned within line of sight to the remote sensor on the camera. Once positioned, the remote transmits a signal through the optic when the button is depressed. The arm can be extended up to 12" and coils down to approximately 3" in diameter. The FLEX's all metal construction will stand up to the everyday rigors of HD DSLR video production and is powered by 2 AAA batteries (included).



FLEX-RC1 DSLR Remote (SWFLEXRC1) **149.95**

PowerBase 70

Battery Pack for Canon EOS 5D MKII and EOS 7D DSLRs

The PowerBase 70 contains a 70 Wh, 14.8v lithium-ion battery designed to extend HD movie recording time for the Canon EOS 5D Mark II and EOS 7D digital cameras. The PowerBase 70 delivers 6x more power than the original battery supplied with the camera.

It is also intended to streamline your HD movie recording: the PowerBase 70 mounts under the camera and doubles as a grip or can be attached to an HDSL support via its 1/4"-20 release plate or V-Mt mount. Wired as a 14.8v battery pack, it can provide extended power for up to two additional 12v DC devices such as lights, monitors or HD converters as well as other devices requiring lower voltage (an optional XP power regulation cable is needed). The pack is also furnished with 1/4"-20 threads on either side to mount accessories. (Does not include a charger).



- Attaches to the camera with the supplied quick release plate to make attaching and detaching the Powerbase 70 from the DSLR rig easy.
- Furnished with 1/4"-20 threads on either side for easy mounting of production accessories
- Two PowerTap outputs power lights, monitors, HD converters, hard drives, etc.
- A four LED indicator gauge allows you to check charge capacity at any time.

PowerBase 70 (SWPB70) **349.95**
Charger for PowerBase 70 Battery (SWPB70C) **44.95**
PowerBase 70 Kit with Charger (SWPB70K) **374.95**
Replacement Quick Release Plate for PowerBase (SWPB70QR) **24.95**

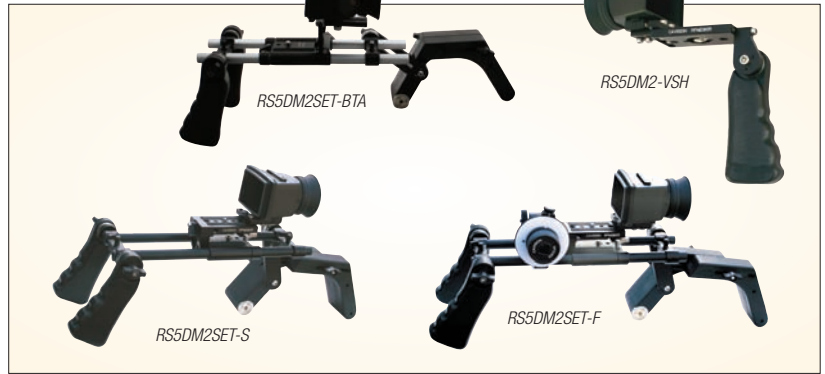

RS5DM2SET-F DSLR Shoulder Mount System

Allows you to work with a HD/SLR utilizing the stability of shoulder-mount equipment. System includes a shoulder pad, rod support, handgrips, follow focus, and a swing-away viewfinder adapter. Height alignment of LCD viewfinder is intended for the Canon EOS 5D MKII and may not align properly with other cameras. For use with the EOS 7D, an additional RPC4580 spacer plate is required.

- Broad chimney viewer for the 3" LCD screen
- Mini DV 15mm aluminum rods support-base allows use of a matte box or other accessories ahead of camera
- Dual handgrips spaced 60mm apart
- Follow focus for DSLR camera with video capabilities

(CAR5DM2SETF).....**849.95**

RS5DM2SET-S DSLR Shoulder Mount System

Allows to work with a video DSLR utilizing the stability of shoulder-mount equipment. Same as above without the follow focus, this package includes rod support, handgrips, and a viewfinder adapter. (CAR5DM2SETS).....**499.95**

RS5DM2SET-BTA DSLR Shoulder Mount System

Same as above, except designed specifically for the Canon EOS 5D MKII when used with either a battery grip or a Beachtek XLR audio adapter. (CAR5DM2SABT).....**499.95**

RS5DM2-VSH

DSLR Single Handgrip Viewfinder Package

An economical yet professional way to capture handheld video with an HD/SLR camera, this package lets you work with a Canon EOS 5D MKII (or similar-sized DSLR) using a stable handgrip and great LCD viewing hood system. Package consists of an attachment point for the SLR, a complete viewing hood system for 3" LCD screens, and an adjustable handgrip which has horizontal and fore/aft adjustment as well as full tilt adjustment. (CAR5DM2VSH).....**199.95**



Ikan Elements

The ikan Elements line is about your needs as a shooter. Simple pieces that allow you to mount your monitor, microphone, light, power supply or whatever else you can think of to your camera setup, while providing you with proper support to get a great hand held shot. The concept is simple... provide you with the parts you need to configure your camera rig how you want it. Order just the parts you need, or get a pre-configured kit. Either way, the choice is yours about how your camera rig turns out.

Starter Fly Kit

Made of anodized aluminum and comprised of three easy-to-assemble parts, the Starter Fly adds comfort and image stability to the often awkward process of shooting video with a digital still camera. Consists of a single foam-grip handle with an attaching, movable arm and a Cheese Plate that can accommodate optional accessories with 1/4"-20 mounts. (IKLEFLYS).....**109.95**

Basic Fly Kit

Stepping up, the Basic Fly kit is comprised of 5 basic parts. Not as heavy or cumbersome as a full rod system, it consists of two foam-grip handles with two attaching, movable arms and a base plate that can accommodate optional 15mm rods to allow for added accessories. (IKFB).....**229.95**

Deluxe Fly Kit

Same foundation as the Basic kit — two foam-grip handles, two attaching, movable arms, and base plate — plus, it adds a rod mount to accommodate the two included 15mm rods. These provide added flexibility to the rig, affording greater control over camera balance and placement while allowing the use of additional accessories. (IKFD).....**329.95**

Super Fly Kit

The Super Fly Kit represents the top of the line in ikan's Elements series of video support equipment — a lightweight, modular support rig designed to work with any DSLR or other small camera. Made of anodized aluminum and comprised of 11 basic parts, the Super Fly adds comfort and image stability to the often awkward process of shooting video with a digital still camera.

Not as heavy or cumbersome as a full rod system, the Super Fly uses the same foundation as the Deluxe kit — two foam-grip handles, two attaching, movable arms, cheese plate, rod mount, and two 15mm rods — to which are added two handle arms and a second cheeseplate. These provide a platform above the camera for mounting your accessories of choice, from lights to monitors to microphones. (IKFU).....**419.95**



Fly Packs (With Super Fly Kit)

Fly Pack 1 DSLR Bundle with V5600:

Includes 5.6" monitor with power, 150W LED light kit, sunhood, 6" and 10" monitor arms, 15mm rod adapters and large transport bag. Available for Canon (IKFP15P), Panasonic (IKFP15P) or Sony (IKFP15S).....**1729.50**

Fly Pack 1 DSLR Bundle with VX7:

Includes 7" monitor with power, 150W LED light kit, sunhood, 6" and 10" monitor arms, 15mm rod adapters and large transport bag. Available for Canon (IKFP17C), Panasonic (IKFP17P) or Sony (IKFP17S).....**1963.95**

Fly Pack 2 DSLR Bundle with V5600:

Includes 5.6" monitor with power, sunhood, 6" monitor arm, 15mm rod adapter and large transport bag. Available for Canon (IKFP25C), Panasonic (IKFP25P) or Sony (IKFP25S).....**1399.95**

Fly Pack 2 DSLR Bundle with VX7:

Includes 7" monitor with power, sunhood, 6" monitor arm, 15mm rod adapter and large transport bag. Available for Canon (IKFP27C), Panasonic (IKFP27P) or Sony (IKFP27S).....**1634.95**

Fly Pack 3 DSLR Bundle with V5600:

Includes 5.6" monitor with power, sunhood, 10" monitor arm, 15mm rod adapter, tripod mounting plate and compact transport bag. Available for Canon (IKFP35C), Panasonic (IKFP35P) or Sony (IKFP35S).....**1399.95**

Fly Pack 3 DSLR Bundle with VX7:

Includes 7" monitor with power, sunhood, 10" monitor arm, 15mm rod adapter, tripod mounting plate and compact transport bag. Available for Canon (IKFP37C), Panasonic (IKFP37P) or Sony (IKFP37S).....**1634.95**

Talon Kit 1

Designed for use with the Hawk or third-party viewfinders. It consists of a standard talon quick release baseplate, stainless-steel L-bracket, and 90mm stainless-steel rod extensions (female threaded on each end). You can attach the optional Letus Hawk view finder directly to the Talon baseplate or to the quick release camera plate depending on whether you want the viewfinder to remain with the camera or the support rods. The back of the standard Talon base plate is also ported to receive standard, male threaded 15mm support rods. This allows you to easily mount accessories behind the camera if needed. (LELTTLK1)**644.95**

Talon Kit 2

Same as above, except it adds Letus Hawk Viewfinder (LELTTLK2)**994.95**

Talon Kit 3

Same as Talon Kit 1, except it uses the extended base and Talon riser, which allow you to have a 'step' in the telescoping support rods. The 90mm stainless steel front rod extensions can be used for easily repositioning a follow focus or matte box when changing the lenses. The riser also provides more vertical clearance, and is ideally used with large cinema lenses where vertical clearance and adjustments are crucial for accessories. (LELTTLK3)**1044.95**

Talon Kit 4

Same as Talon Kit 2 except it adds telescoping rods that are mounted directly below the Talon quick-release baseplate with the extended base system. This is the most compact method for having telescoping support rods. The extended base can also be used with static / non-telescoping support rods if desired. (LELTTLK4)**1244.95**

Talon Kit 5

Same as Kit 3, except it adds Letus Hawk Viewfinder (LELTTLK5)**1374.95**



Letus Hawk DSLR Viewfinder

The Letus Hawk DSLR carbon fiber viewfinder is made for DSLR filmmakers who want quality optics, solid construction, and the ability to accommodate their specific shooting needs. Uses 3 lenses in 2 groups of fully coated optics rather than a single, off-the-shelf diopter, and offers 2.75x view factor—the ideal zoom for LCD screens. The lenses are adjustable from +1.5 to -2.5 to accommodate near and far sighted users. Also features removable eye cup, talon basic camera plate for mounting, X / Y / Z mounting adjustments, and 1/4-20 mount point for articulating arms (LELTHKVF) **384.95**

Letus Talon DSLR Camera Cage

The Letus Talon DSLR cage has a releasable camera plate along with a sliding / removable top bridge. The camera plate can be attached from the bottom or the front of the cage for easy camera removal when transporting. The top bridge can slide on standard 15mm diameter rods. Add any length of support rods you need to accommodate your top bridge setup. Because the top bridge can slide forward and backward, it makes for a very versatile DSLR rig that is easy to balance. The cage can also be quick released for break down and storage. The bottom of the DSLR cage is ported for battery access. Canon EOS 5D MKII and EOS 7D. Extended side risers are available if you are using the Canon 1D Mark IV or other, taller, DSLR cameras. Provides a myriad of mounting points for virtually any setup you can dream of. A great platform for mounting handgrips, preview monitors, mics, sound recorders, lights, support rods, mixers, batteries, other DSLR cages, etc. (LELTCAGE) **.689.95**



DSLR Rig

By configuring the Proteus Rail System for cameras such as the EOS 5D MKII and EOS 7D, and Nikon D3S, Cinevate gives DSLR filmmaker a perfect blend of support, functionality, and customization. The Monstor grip handles and 15mm carbon fiber rods combine with an adjustable shoulder pad to form a sturdy, lightweight rig that allows for comfortable, all-day shooting.

Fully configurable to each shooter's needs, the DSLR Rig can be outfitted with a wide range of professional accessories, from the Durus Follow Focus and Matte Box to the Proteus Cage. And if you need to shoot with something besides a DSLR, no problem: the DSLR rig will support video camcorders, too.

The base plate ejects straight up and offers a multitude of configurations, none of which protrudes below the rails. Height, XY adjustment, rake angle and placement of the rails blocks are all variable. (CISR)**929.95**

Uno DSLR Rig

With a foundation consisting of a 15mm carbon fiber rod chassis and camera baseplate, the Uno provides a unique link system – and a variety of optional camera platforms – that allow for endless configuration to suit your body type and shooting preferences. Follow focus, long lens support, shoe mounts and other 15mm rod-based accessories can be easily added, allowing for even more professional-looking results. The base plate ejects straight up and offers a multitude of configurations, none of which protrudes below the rails. Height, XY adjustment, rake angle and placement of the rails blocks are all variable. The base plate is also the basis of our shoulder support system. (CISR)**874.95**

Uno Grip

The Uno Grip is designed as an additional grip for Cinevate's Uno, Medusa and Proteus DSLR support systems. Able to be mounted and configured just about anywhere on your rig, the grip uses a single "Kip" handle for no-tools adjustment at just about any angle or in just about any direction. The grip also contains a 1/4"-20 female thread underneath for additional mounting possibilities. (CIGH)**148.95**



Medusa DSLR Cage

The Medusa DSLR Cage brings a dovetailed quick-release plate and 15mm rod support to a highly customizable DSLR accessory frame. Eight swivel joints, 4 kip handles, and two form-fitted handgrips let you adjust the width and height of your rig for maximum comfort and stability. Lights, microphones, and other peripherals – including jibs – can attach to the top accessory plate, while the bottom 15mm rod clamps attach to standard 15mm rod/rail systems, allowing for further levels of customization. (CIMC)**639.95**



microFollowFocus v2 Indie Bundle

Compatible with all camcorders and DSLRs, this bundle lends your video production the precise focus control of a big-budget film. Whether shooting with a fixed-lens camcorder, interchangeable cinema lenses, or and HD/SLR, the precision-machined, gear-driven design provides repeatable, accurate focusing. The included microLensGears enables an exact fit between your 35mm SLR lens and the microFollowFocus, allowing more precise and fluid focus adjustments.

- Completely gear-driven design for slip-free, accurate, and repeatable focus movement. 1:1 gear ratio allows smooth movements for still and motion picture 35mm lenses. Optional reversing gear focuses Nikon and Pentax lenses in the "correct" cinema direction

(RE80030020) **693.50**

microShoulderMount for 35mm Adapters Bundle

Turn nearly any camera into a portable, shoulder-mounted production rig. Whether you're shooting with a tiny consumer camcorder, a video DSLR, or an ENG-style camera and 35mm lens adapter, this kit not only increases the stability of handheld shooting, it provides new levels of flexibility to how you shoot.

The shoulder pad and two rubberized handgrips can be adjusted in nearly any configuration along the included handlebar rods and optional 15mm support rods. At the same time, with the addition of a Redrock microMount, the rods can be used to support a host of accessories, from articulating arms to external monitors, batteries and portable hard drives. (RE80030022) **469.95**

microShoulderMount Deluxe Bundle

Includes everything in the microShoulderMount Bundle, and adds 18" rods. The Deluxe Bundle is great for camera setups that don't already have a rod support system. (RE80030023) **559.95**

microMount (3-pack)

The microMount is a flexible connector that allows just about any item to be connected to 15mm rods. The microMount includes ¼" 20 mounts to accommodate connections with on-board monitors, noga arms, and other accessories. microMounts can also be used to configure entirely new camera support configurations by connecting additional rods and other microMounts. (RE80030024) **199.95**

microFollowFocus v2 Complete Package

Nearly everything you'll need to achieve smooth, accurate, professional focus. Compatible with all camcorders and DSLRs, the microFollowFocus v2 lends your video production the precise focus control of a big-budget film. Whether shooting with a fixed-lens camcorder, interchangeable cinema lenses, or a video-capable DSLR, the precision-machined, gear-driven design provides repeatable, accurate focusing. (microLensGears must be purchased separately.)

Three high-quality Arri-style microWhips – in lengths of 3", 12", and 18" – fit into the accessory port of the microFollowFocus unit, letting you pull focus at a distance from the camera. Solidly built – with rubberized handles and rugged locking inserts – these whips also work with other standard follow focus units.

The included microSpeedCrank is an extended arm that also uses an Arri-style connector to fit into the microFollowFocus, giving you the ability to pull focus much more rapidly. (RE80030025) **825.00**

DSLR Cinema Bundle

The DSLR Cinema Bundle provides you with a modular, tripod-mounted system that includes swing-away matte box, geared follow-focus, top handgrip, DSLR plates, support cage and quick-mounting rod clamps – all on a dual 15mm carbon-fiber-rod system that can be customized as needed.

Compatible with most video DSLRs – including the Nikon D90, D300s, D3s, and Canon EOS 5D MkII, EOS7D, and EOS 1D Mark IV, the DSLR Cinema Bundle provides a platform for a wide range of additional accessories, such as an articulating arm or external monitor. Lens gears must be purchased separately. (RE80030054) **2412.00**



microMatteBox Deluxe Bundle

The Redrock Micro microMatteBox Deluxe Bundle is a universal matte box system that accommodates any lens – whether camcorder, film camera, DSLR or 35mm lens adapter. With its convenient swing-away design, this cinema-grade lens attachment allows the use of 4x4" and 4x5.65" professional filters that can rotate 360° or be easily swapped out for different looks. Light spillage and lens flare are controlled by a top/bottom French flag and a pair of side wings that, like everything else on the microMatteBox, can be easily locked, adjusted or simply removed.

Configurability is key, and not only of filters, flags, and side wings: optional Redrock accessories include the 15mm microSupport system as well as additional filter stages. And since the microMatteBox uses industry standard support and filter sizes, it's completely compatible with existing 15mm and 19mm rod/rail systems. With its high-quality design and affordability, the microMatteBox system is built for productions small, large, or anywhere in between. (RE80030043) **974.95**

microMatteBox Deluxe Bundle for RED One

Upgrades the 15mm swing-away support arm of the Deluxe Bundle to a 19mm/15mm arm. Along with the RED One, this universal matte box system will accommodate any other camcorder, film camera, DSLR or 35mm lens adapter. With its convenient swing-away design, this cinema-grade lens attachment allows the use of 4x4" and 4x5.65" professional filters that can rotate 360° or be easily swapped out for different looks. Light spillage and lens flare are controlled by a top/bottom French flag and a pair of side wings that, like everything else on the microMatteBox, can be easily locked, adjusted or simply removed. (RE80030044) **1094.95**

DSLR Field Cinema Deluxe Bundle

Comprehensive package for converting video DSLRs to useful cinema production rigs. This rig is ideal for DSLRs that have the ability to output an HD picture to an external monitor while recording. Having an HD monitor opens new doors like the ability to allow a Camera Assistant to pull focus as opposed to the operator. It also allows users to take full advantage of the features that professional HD monitors offer.

(RE180010002) **1889.95**



Ultraport DSLR Bundle

Bundled kit designed to turn your DSLR hybrid camera into a professional video rig. This model features a two-grip configuration that minimizes rotation while you shoot. The system makes it easy to remove the camera from the rods with the DSLR baseplate's quick-release system. Choose to shoot with just the camera or shoot handheld with grips. The system can be further customized with a number of separately available accessories. (RE80030089) **524.95**

theEvent DSLR 2.0 Hybrid Rig

Designed to turn your DSLR hybrid camera into a professional video rig. This model is a stabilized rig designed with wedding, event, or photojournalism shooters in mind. It features two handgrips, a microFinder loupe eyepiece (loupe purchased separately), and microBrace body pad. This setup is intended to afford maximum stability and mobility with a very low overall weight. (RE80170016)..... **849.49**



eyeSpy



theEvent DSLR 2.0 Hybrid Rig



Ultraport DSLR Bundle

eyeSpy Standard • eyeSpy Balance • eyeSpy Deluxe

For a more traditional shoulder mount shooting style, try the EyeSpy rigs which come in three configurations:

- A cost-effective base package, the EyeSpy Standard starts with the shoulderpad, 18" 15mm carbon fiber rods, and single rubberized handgrip from the popular microShoulderMount. Then adds additional rod extension to center the camera for viewfinder use, and tops it off with the DSLR baseplate, and microFinder loupe accessory (loupe not included).
- eyeSpy Balance adds microBalance counterbalance weights for a rig that is easier on the arms for extended shooting.
- eyeSpy Deluxe Bundle adds the microFollowFocus v2 for convenient, precise control over focusing your SLR lenses

eyeSpy Standard (RE80170011).....	eyeSpy Balance (RE80170012)	eyeSpy Deluxe (RE80170010)
824.95	1043.99	1549.95

Z-Finder Jr. DSLR Optical Viewfinder

Whether shooting handheld or on a tripod, the Z-Finder Jr. turns your camera's 3" LCD screen into a clear, easy-to-focus viewfinder that lets you see your image in magnified detail even under the brightest sunlight. It also provides an extra degree of handling comfort and a crucial point of contact — between camera and eye — that adds stability to any handheld video. Features 2.5x focusable magnification, a 40mm diameter Zacuto optical design lens, a large form fitting eyecup preventing extraneous light leakage, and a field of view perfectly matched to 3" LCD screens. (ZAZFINDJR)..... **249.00**

Z-Finder Pro (2.5x & 3x Magnification)

The Z-Finder Pro offer a 40mm diameter optical design lens, an anti-fog coating protective lens cover, a large eyecup preventing extraneous light leakage and a field of view perfectly matched to 3" LCD screens. With the expendable anti-fog protective covers, going between extreme environments won't be a problem. Otherwise the same, if you are nearsighted the 2.5x might be for you as it offers a -4.75 correction, where as the 3x offers a -2.75 negative correction. If you are not nearsighted, then it is just a personal preference on magnification.

Z-Finder Pro 2.5x (ZAZFINDPRO2).....	375.25
Z-Finder Pro 3x (ZAZFINDPRO3).....	375.25



Target Shooter

The perfect solution for no-fuss run-and-gun DSLR video production, the lightweight Target Shooter offers finite adjustability and three points of contact for enhanced stability. Included Gorilla plate attaches to the bottom of your camera via standard 1/4"-20 mount, and is joined to the rest of the Shooter via an included 15mm rod. With the gunstock pressed against your body, you can adjust height and angle for the most comfortable fit, bringing the ergonomics and stability of a camcorder to your DSLR. (ZAZDTS) **449.95**

Striker

Striker takes the gunstock and Gorilla Plate of the Target Shooter and adds a handgrip for waist-level support. (ZAZDSR) **894.95**

Single Action

Single Action is a set of mini-rails and baseplate that attach to your tripod and allow for easy mounting of your video DSLR. In conjunction with the included Z-Focus, two universal Ziggears are cut to size to give you smooth, precise follow-focus ability over two lenses, while a quick-release plate lets you easily switch the camera between tripod and handheld use. (ZAZDSA)..... **1699.95**

Cross Fire

Cross Fire brings together the handgrip, gunstock and adjustable 15mm rods of the Striker with the follow focus of the Single Action kit to deliver a versatile, lightweight support rig for any DSLR. Shoot smooth handheld video one moment, then mount the rig intact to your tripod using the included baseplate. The camera's quick release plate allows for easy removal, while the 0.8 pitch Ziggear can be cut and sized to match your lens of choice for precise, accurate follow focus. Additional Ziggears required for additional lenses. (ZAZDCF) **2474.95**

Fast Draw

Fast Draw helps you turn any video DSLR into a professionally shoulder-mounted camcorder. The adjustable handgrip and shoulder pad provide the stability and comfort needed for long handheld shoots, while the Z-lite Double counterbalance weight keeps your rig from getting too front-heavy--aiding immensely in maneuverability while lessening fatigue. Plus, you can easily mount the entire rig onto a tripod using the DSLR baseplate. The Fast Draw can be configured for either the left or right shoulder, and will support an optional follow focus and matte box with additional 15mm rods. (ZAZDFD)..... **1539.95**

Double Barrel

Combines the Cross Fire with the Fast Draw and adds dual grips and a Z-Finder Pro 2.5x, giving you the ability to virtually wear your DSLR to the shoot. (ZAZDSB)..... **3694.95**



Precision Optics Series

Professional Digital Video Series Lenses



Professional Camcorders	Sony HDR-FX1, HVR-Z1U	Panasonic AG-HVX200	Canon XL-1s, XL-2, XL-H1	Panasonic AG-DVX100(A)
1.6x Telephoto Extenders	VS16TC-HDS 849.95	HD16TCHVX 799.95	HD16TCXLH 799.95	VS16TCDVX 849.95
0.6x Wide-Angle Adapter	VS06WA-HDS 354.95	HD06WAHVX 344.95	-	VS06WADVX 349.95
0.7x Wide-Angle Converter	VS07CV-HDS 649.99	HD75CVHVX 935.39	VS07CVXL2 568.99	VS07CVDVX 619.99
Fisheye Adapter	VSFWEA-HDS 449.95	HDFEWAHVX 2599.95	HDFEADXLH 449.95	VSFWEADVX 2799.95

Digital Series Lenses

	VX2100 PD170/250	Sony PDW-EX1	XH-A1 XH-G1	HDR-FX7 HVR-V1U
2x Telephoto Converter	DS-20TC-SB \$409.95	HD-16TC-EX1 (1.6X) \$849.95	OHD-16TC-XLH (1.6x) \$709.95	OHD-20TC-SH6 \$1294.95
0.55x Wide-Angle Adapter	DS-55WA-58 \$289.95	HD-06WA-EX1 (0.6x) \$399.95	OHD-06WA-XLH (0.6x) \$399.95	OHD-55WA-SH6 \$349.95
0.65x Wide-Angle Converter	DS-65CV-58 \$449.95	-	VS-08CV-72 (0.8x) \$519.95	OHD-65CV-SH6 \$499.95
0.3x Ultra Fisheye Adapter	DS-FEWA-SB \$799.95	HD-FESU-EX1 (1.6x) \$529.95	OHD-FE3X-XLH \$812.50	HD-FE3X-SH6 \$879.95
Extreme Fisheye Adapter		HD-FEWA-EX1 \$2,694.95		

Lenses for DV Cameras with 27-37mm Lens Mounts

Include 27mm, 30mm, and 30.5mm Step Rings

#DS-55WA-37	0.55x Wide-Angle adapter	\$124.95
#DS-HR65-37	0.65x Wide-Angle converter	\$229.95
#DS-FEWA-37	0.3x Ultra fisheye adapter	\$329.95
#DS-HR20-37	2x Telephoto converter	\$219.95

VS-08CV-72

Compact, lightweight 0.8x HD quality wide-angle lens converter with 20% wider coverage and full zoom-through capability. Affixes to 72mm lens mts.

#CEVSO8CV72 484.95



Wide-Angle & Telephoto Lens Recommendations

for DV and High-Definition Camcorders



	0.7x Wide Angle (169-HD7X-62) (169HDV7XH100)	EX 0.45x Super Fisheye (169-HDV5F5X-82)	EX 0.75x Wide Converter (169-HDV75X-82)	EX 1.5x Tele Converter (169-HDVT15X-72)	COMBO EX 0.45x & 0.75x (169-HDSFWA75)
Canon XH-A1			X	X	
Canon XH-G1			X	X	
Canon XL-H1				X	
Canon XL-2				X	
Sony HVR-FX1				X	
Sony HVR-Z1			X	X	
Sony HVR-Z7U			X	X	X
Sony HVR-S270U			X	X	X
Sony HVR-V1U				X	
Sony HVR-FX7				X	
Panasonic HVX200		X	X		X
Panasonic DVX100B		X	X	X	X



Video Pro Conversion Lenses

Impact's high-quality conversion lenses are manufactured with premium workmanship, resulting in superior, high-resolution image capture. The lenses are available in several categories: telephoto, wide-angle, macro/close-up, and fisheye. They mount directly onto digital and video camcorders. Impact lenses with a magnetic base will magnetically mount directly to your digital camera or camcorder.



Model#	Lens Mount	Description	SKU	Price
DVP-SWA38-37	37mm	0.38x Super Wide-Angle	#IMDVPSWA3837	79.95
DVS-TP20-37	37mm	2.0x High-grade Telephoto	#IMDVSTP2037Q	29.95
DVP-WA50-58	58mm	0.5x HG W/A w/Macro	#IMDVPWA5058	149.95
DVP-TP20-58	58mm	2.0x High-Grade Telephoto	#IMDVTP2058	89.95
DVP-WA70-62	62mm	0.65x Wide-Angle	#IMDVPWA6562	89.00
DVP-TP20-62	62mm	2.0x High-Grade Telephoto	#IMDVTP2062	69.95
DVP-WA70-72	72mm	0.7x Wide-Angle	#IMDVPWA7072	279.95
DVP-TP20-72	72mm	2.0x High-Grade Telephoto	#IMDVTP2072	99.95



Video Conversion Lenses



Model	Lens Mount	Description	SKU	Front Thread	Adapters	Price
XL-3000PRO	52-67mm	0.3x Ultra Wide Angle	RAXL3000PRO	N/A	Snap-on	99.95
HD-7000P58	58mm	0.7x HQ Wide Angle	RAHD7000P58	82mm		146.99
DCR-7900ZD	58mm	0.79x Wide-Angle	RADCR7900ZD	92mm		209.95
MX-3062	62mm	0.3x Semi Fisheye	RAMX3062	N/A		134.95
HD-7062	62mm	0.7x HQ Wide-Angle	RAHD7062	82mm		132.00
DCR-CF187P	62mm	185° Fisheye	RADCRFE187P	N/A	43, 52, 55, 58	439.99
HDP-6000EX	72mm	0.79x HD Wide-Angle	RAHDP6000EX	117mm		399.95
DCR-5320PRO	72mm	3-In-1 HD Macro	RADCR5320PRO	72mm		199.95
HD-FXR180	72mm	0.24x HD Fisheye	RAHDFXR180	N/A		509.95
HDP-9000EX	72mm	1.8x HD Telephoto	RAHDP9000EX	108mm		779.95



EX-II Video Pro Conversion Lenses



EXII 0.45X Super Fisheye

16x9 Inc. upgrades its EX line of specialized lens attachments with the high-definition-quality EXII 0.45X Super Fisheye. The single-element EXII 0.45X Super Fisheye offers significant improvements in design and functionality.

- Single Element • 135° Field of View • Lightweight Design

0.45X Fisheye Converter Lens Available with 62mm, 72mm, 77mm, 82mm, HP, EX or HV mount #169HDSF45X* **399.95**

EXII 0.6X Wide Angle Converter Lens

- 40% Wider Image • Partial Zoom Through • Lightweight Design

0.6X WA Lens with 62mm, 72mm or 82mm #169HDAWA6X* **274.95**

0.6X WA Lens for EX, HPX, HVX or Z5 #169HDAWA6X* **294.95**

35mm Lens Adapters

Depth of Field and the Elusive "Film Look"

Achieving a genuine film look on video takes more than good lighting and 24fps progressive capture. The shallow, controllable depth of field and high-grade optics of 35mm prime lenses are also needed. The Letus 35 and Cinevate's Brevis35 allow you to attach still photography lenses onto nearly any SD or HD camcorder, projecting their rich, film-like images onto an internal translucent screen which your camera then records.

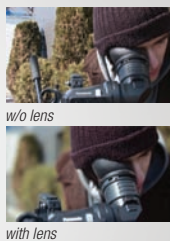

W LENS ADAPTER SYSTEMS

Letus35 Extreme

With its high-grade achromatic lens and 1/2-stop light loss, the Letus35 Extreme exhibits beautiful film look with absolutely no vignetting and superior edge-to-edge sharpness. Its proprietary image orientation technology flips the image upright—without the added expense and inconvenience of an external adapter.



- Interchangeable thread rings and lens mounts for changing cameras on-the-fly
- Virtually silent vibration system
- Built-in LED on/off indicator
- Comes with choice of mount

#LELT35EX72 with 72mm filter ring.....**1074.95**

Extreme Starter Cine Bundles

Each includes Extreme Adapter, Rod Support System, Nikon lens mount, camera connection, Zeiss lenses and custom case.

- For Panasonic HVX-200** #LELTEXSCKHVX..... **6286.50**
- For Sony PMW-EX1/EX3** #LELTEXSCKEX..... **6039.95**
- For 72mm Camera Connection** #LELTEXSCK72 **6116.50**
- For 77mm Camera Connection** #LELTEXSCK77 **6116.50**
- For 82mm Camera Connection** #LELTEXSCK82 **6038.95**

Letus35 Elite Adapter

The Letus35 Elite Adapter offers similar features to the Extreme adapter and adds a back focus adjustment.

- With Panasonic HVX-200 Ring** #LELT35ELTHV..... **1749.95**
- With Sony PMW-EX1/EX3 Ring** #LELT35ELTEX..... **1749.95**
- With 82mm Ring** #LELT35ELT82..... **1749.95**
- With 77mm Ring** #LELT35ELT77..... **1749.95**
- With 72mm Ring** #LELT35ELT72..... **1749.95**

Letus35 Ultimate

The top-of-the-line successor to the widely acclaimed Letus 35 Extreme, the Ultimate completely raises the bar on 35mm adapters by offering a new multipatented design and the highest-quality achromatic lenses. Along with a quieter, "smart" spinning ground glass element with zero wobble, the Ultimate contains a precision back-focus adjustment and can stop down to f/22. Its built-in flash memory remembers your last settings, while the supplied D-tap power cord is hot swappable. Stunningly beautiful, film-like images were never so affordable. Includes PL mount, choice of optimization kit, D-tap, custom waterproof case, and rod support bracket.



- User-changeable ground glass element
- Variable RPM motor with LED display
- Off-center spinning glass and driving motor

#LELT35ULT72 with 72mm filter ring..... **3994.95**
 #LELT35ULTEX1 with PMW-EX1 ring..... **3949.95**

Letus35 Mini

Designed and optimized for cameras with a 43mm filter size or smaller, the Letus35 Mini brings all the impressive features of the Letus35 Extreme to consumer camcorders like the Canon HV30 and Sony HC9. Now you can achieve cinema-like image quality with a minimum of equipment and cost.

- Less than 2 lbs
- No support rods necessary
- 16:9 native aspect ratio
- Great in limited space

#LELT35M37 with 37mm ring..... **774.95**
 #LELT35M43 with 43mm ring..... **774.95**



RELAY LENSES

Letus 2/3" B4 Compact Relay Lens

This relay lens will allow you to attach a Letus35 Extreme, Elite, or Ultimate adapter directly to the camera body bypassing the stock lens entirely. Precision calibrated to the Letus35 adapters, features academy frame size, 9 lens set, razor sharp center and edges, iris ring, back focus ring with lock down, stainless steel flange



#LELTB4C **2994.95**

Letus 2/3" B4 Pro Relay Lens

Pro version of the B4 compact relay lens. 103mm in length from flange. 3/4 stop brighter than the P+S PRO35 relay.



#LELTB4P **4399.95**

LT13FFPRO 1/2" Relay Lens

Designed for camcorders with 1/2" image sensors and interchangeable lens mounts, the Letus 1/2" Relay Lens can be mounted directly to the camera, letting you attach Letus 35mm adapters--such as the Extreme, Elite, or Ultimate--with minimal light loss. These adapters allow your camera to achieve reduced depth of field and thus more cinematic imagery. Compatible cameras for this lens include the Sony PMW-EX3.



#LELT12FFPRO **2874.95**



CAMERA SUPPORT SYSTEM



On Camera

LTRAPTOR Camera Support System

Professional, lightweight support rig that brings a new level of ease to using on-camera accessories. Quick-release V-plate combined with a V-wedge camera plate and telescoping support rods gives you a compact, adjustable base that mounts to any tripod, no matter which camera you use.

- Raptor Camera Support System** with Light Camera Plate, V-Plate Block and Tele Support Rods #LELTRAPTOR... **1194.95**
- Raptor Light Camera Plate** #LELTRAPTORLC..... **444.95**
- Raptor V-Plate Block** #LELTRAPTORVB..... **594.95**
- Telescopic Support Rods** Perfect for Matteboxes, extends 9.4-13", 15mm rods #LELTRAPTORT..... **294.95**

RELAY LENSES

Letus 1/3" Pro Relay Lens

The Letus 1/3" relay lens is designed for cameras with a 1/3 inch image sensor and removable lens system. The Letus relay will allow you to bypass the stock lens of your camera and attach a Letus adapter (Extreme, Elite, or Ultimate) directly to your camera body on cameras with removable lenses with standard 1/3" mount such as the Panasonic HPX300 and JVC HD series.



#LELT13FFPRO **2694.95**

Letus 1/2" Pro Relay Lens

The Letus35 1/2" relay lens is designed for cameras with a 1/2" image sensor and removable lens system. The Letus relay will allow you to bypass the stock lens of your camera and attach a Letus adapter (Extreme, Elite, or Ultimate) directly to your camera body on cameras with removable lenses such as the Sony PMW-EX3, XDCAM 350/355, etc.



#LELT12PRO **3494.95**

Director's Viewfinders

VFM-11X
Micro Director's Viewfinders

The VFM-11X micro zoom viewfinder covers focal lengths from 8mm to 80mm for 1" and 2/3" chip standard and high-definition digital cameras, 16mm focal lengths of 8.5mm to 94mm, and 35mm focal lengths of 18mm to 200mm. Aspect ratios are 1.33 (TV), 1.66, 1.78 (HDTV), 1.85 and 2.35. Aluminum, 4-element coated optics.



VFM-11X (11x zoom) #CADVMFZQ..... **239.95**

Du-All Camera

MICROFINDER Director's Viewfinder

Machined from high-quality aluminum, the Director's Viewfinder switches between various film standards, from anamorphic to Super16 and 35mm. It also has settings for 1/3", 1/2" and 2/3" video formats.



- 11x zoom ratio
- Lightweight, durable
- Comes with carrying case and neck strap

#DUMF11X6FRB Red Barrel..... **259.95**

#DUMF11X6F Black Barrel..... **264.95**

MARK VB
Director's Viewfinder

Winner of a Technical Achievement Award from the Academy of Motion Picture Arts and Sciences.



- Smooth 12x zoom ring
- Focal lengths viewed in windows on viewfinder barrel
- Adjustable aspect ratio ring (1.33:1, 16x9, 1.85:1, 2.40:1 anamorphic)
- 6 glass elements for sharpest possible image
- Color coded film sizes and video formats
- Adjustable focus ring and rubber eyecup

#ALDVMF5B..... **694.95**

Birns & Sawyer

UNIVERSAL MINI/MICRO

Director's Viewfinders



The Universal Mini Viewfinder comes with digital scales for Canon, Sony, and other 1/3" chip cameras. It covers 16mm and 35mm film formats as well as 1/2" DV and 2/3" HD cameras. Focal lengths are 4mm to 35mm for 1/3" chip cameras such as the Canon XL and Panasonic's DVX line. Focal lengths are: 8mm–80mm (2/3" cameras), 8.5mm–94mm (16mm), 18mm–200mm (35mm).

#BIMVF (162129) Mini Universal..... **374.95**

#BIMVFQ (162128) Director's Micro Viewfinder. **234.95**

MB-44 Series 4x4 Bellows Matte Box Kits

Designed to work with pro camcorders, these kits include: Bellows matte box, 15mm rod support system, ring adapter, and French flag.

#CAMB44SENGN f/Sony ENG Cams..... **549.95**

#CAMB44DVXN f/XL-2 and AG-DVX100A/B..... **599.95**

#CAMB44PD170N f/Sony PD170/VX2100..... **599.95**

#CAMB44HD100 f/PD-170-2100..... **649.95**

#CAMB45HVX200 f/Panasonic AG-HVX200..... **549.95**

#CAMB4510H2EX f/Sony PMW-EX1..... **499.95**

Birns & Sawyer

MB-105 Clip-On Matte Box

Lightweight, clamp-on style matte box with sunshade and French flag. Tray-less design holds 2 4x5.650 glass filters. Available clamp-on and threaded reduction rings make it suitable for lenses with 105mm outer diameter and smaller.

MB-105 with 72mm Ring for Canon XLH1 & Sony DSR-Z1U #BIMB10572..... **649.95**

MB-105 with 77mm Ring #BIMB10577..... **649.95**

MB-105 with 82mm Ring #BIMB10582..... **649.95**

MB-105 with 95mm Ring #BIMB10595..... **649.95**

FM600 SERIES 4x4 Matte Box

The Formatt FM600 4x4 matte box system affixes to lens diameters of 43–82mm with the implementation of an optional Formatt threaded attachment adapter. This matte box features a French flag and 2 filter holders—one fixed, one that rotates 360°.



FM-600 4x4 Matte Box #FOMBFM600..... **Call**

FM-600 Matte Box Kit with filters for Panasonic HVX-200(A) #FOFM600HVXK1..... **Call**

FM-600 Matte box Kit with filters f/Sony PMW-EX1 #FOFM600EXK1..... **Call**

Genus

GC-MB-FF SERIES
4x4 Matte Box System

This lightweight, durable matte box system features two filter holders (one moveable, one fixed), a French flag, a rod support system and an adapter for specific camera compatibility



62mm Rod Support System #GEGMKBAS62..... **799.95**

Rod Support System #GEGMKBAS72..... **799.95**

77mm Rod Support System #GEGMKBAS77..... **799.95**

82mm Rod Support System #GEGMKBAS82..... **799.95**

MB44 SERIES 4x4 Matte Box Kit

Designed to work with a variety of DV/HDV/DVCPRO HD camcorders.

- Moveable "eyebrows" provide extra flare reduction; adjustable to the zoom position of the lens
- Includes rotating filter holders for 3x3 or 4x4 filters; perfect for polarizers and effects filters
- Accessory shoe for fast & simple attachment of a light or mic holder
- Cine-style rails provide solid, quick-adjusting support

f/DVX100B, HVX200 #CEDSMB44WKT..... **1349.95**

f/Sony HDR-FX1, HVR-Z1U and Canon XH-A1 and XH-G1 #CEDSMB44HSW..... **1299.95**

CMB-R20 SERIES 4x4 Sunshade Kits

Control light and filtering with these lightweight, clamp-on sunshades, which incorporate a French flag and two independently rotating filter holders.



For Canon XH-A1 and XH-G1

#CHR20XHAK1..... **834.95**

For Panasonic AG-HVX200/A #CHR20HVXK1..... **834.95**

For Sony HVR-Z7U #CHR20Z7K1..... **764.95**

For Sony PMW-EX1 #CHR20EX1K1..... **834.95**

For Sony PMW-EX3 #CHR20EX3K1..... **834.95**

450 KIT-1 SERIES SYSTEM KITS

4x4 Matte Box Kits with French Flags



Kits include: • Matte box • 16:9 mask

• 4x4 /4x5.65 filter holder • French flag

• Support system with center bracket • 110mm rear plate

• Step-down ring

f/Sony HVR-Z1U #CHDVMB44HDK1..... **Call**

f/JVC GY-HD110U #CHDVMB44HDV1..... **Call**

f/Panasonic AG-HVX200(A) #CHDVMB44HVK1..... **Call**

f/Canon XH-A1/G1 #CHDVMB44XHA1..... **1749.95**

f/Canon XL-H1 series #CHDVMB44XLH1..... **1827.50**

f/Sony PMW-EX1 #CHDVMB44EX1K..... **1749.95**

450 KIT-2 SERIES SYSTEM KITS

4x4 Matte Box w/French Flag and Follow Focus

The 450-HDVKIT2 professional upgrade kits add followfocus, for more precise control of your cine-style image.



f/Sony V1U and FX7 #CHDVMB44E1K2..... **3629.99**

f/Sony Z1U and FX1 #CHDVMB44HDK2..... **Call**

f/Sony PMW-EX1 #CHDVMB44EXK2..... **Call**

f/Sony PMW-EX3 #CHDVMB44E3K2..... **Call**

TIFFEN



44DVFLK | 4x4 Film Look DV Kit

Soften and warm your video image for a more subtle, film-like quality with this excellent set of professional Tiffen filters.

Kit includes:

- 4X4" Black Diffusion F/X 1/2 Glass • 4X4" Black Pro-Mist F/X 1/2 Glass • 4X4" Warm Black Diffusion F/X 1/4 Glass
- 4x4" Soft F/X 1 Glass • Soft pouch

#TIFLDVK44 **699.95**



QUICK START 3

4x4 & 4x5.65 DV/HDV Special Effects Filter Kits

- Low Contrast 1 Glass Filter • Soft Effects Clear 3 Glass Filter
- Supermist Black 1/2 Glass Filter BF 4x5" ACKIT5 (4x5.65")
- Low Contrast 1 Glass Filter • Soft Effects Clear 3 Glass Filter
- Supermist Black 1/2 Glass Filter

BF ASC-QSKIT3 4x4" Filters #FOQS344 **699.95**

BF 4X5-ACKIT3 4x5.65" Filters #FOQS345P **Call**



4x4" Filter Kit for Video Production

Century Filters by Schneider Optics have been specifically selected to meet the unique needs of today's DV/HDV cinematographers. Century 4"x4" filters fit neatly into standard mattebox filterholders.



Century DV/HDV 5-filter kit, includes • Linear Polarizer •

ND .6 Solid • ND .6 Soft Edge Graduated • Black Frost .5

• Skintone Enhancer filters and a lightweight padded pouch

70-C48801 4x4" Filter Kit #CEFTK44 **449.95**

Birns & Sawyer

Professional Acrylic Production Slates

These versatile, dry-erase production slates (clappers) help sync your sound and identify shots on sets and production locations. With inlaid color and durable engraved text, they fit into a standard front-box. Dimensions: 7 1/2 x 11"



425011 Color Clapper Sticks #BISACC **89.95**

425003 Greyscale Clapper Sticks #BISAGC **89.95**

425007 Black & White Clapper Sticks #BIDES **27.95**

Pearstone Acrylic Dry Erase Clapboards

SADB711 With Greyscale Sticks #PESADB711 **44.95**

SADC711 With Color Sticks #PESADC711 **49.99**

HOODMAN
LCD HOODS

Contoured Wrap-Around Viewfinder Hood



Lightweight and durable, the Hoodman H Series provides glare-free viewing of your LCD screen even in bright outdoor light.

#HOHD300V Fits 3" 16:9 LCD screens **19.95** #HOH400 Fits

3-5 4" LCD screens..... 17.95

#HOH600 Fits 6" LCD screens..... **32.95**

#HOH700 Fits 16x9" LCD screens **29.95**

Blue Star



BL-90131 Oval Large Eye Cushion

These high-quality viewfinder eye cushion covers are for pro video camera viewfinders and provide thick, cushioned comfort and absorbency. They come in different sizes, conforming snugly and securely to each manufacturer's eyecup.

#BL90131 Chamois/Oval Large **6.95**

#BL90132 Microfiber/Red/Oval Large **6.95**

#BL90133 Microfiber/Blue/Oval Large **6.95**

#BL90134 Microfiber/Natural/Oval Large **6.95**

#BL90138 Fleece/Red/Oval Large **6.95**

#BL90139 Fleece/Blue/Oval Large **6.95**

Raider

I-CUFFS Viewfinder Hoods

Raider's i-cuff hoods attach securely to your viewfinder via a touch fastener for personalized positioning and fit. Their ultrasuede chamois fabric is waterproof and is crafted to the highest standards of durability and comfort (will still look new after 100,000 rubs).



#RAICUFFHD Fits viewfinders up to 10.5" **44.95**

#RAICUFF Fits viewfinders up to 9.5" **44.95**

#RAICUFFDV Fits viewfinders up to 5.5" **39.95**

DIGITAL CINEMA TRAINING

20-DVD Cinema Production Course



This highly comprehensive, detailed and thorough 20-DVD set was created to address every aspect of digital cinema production. Nothing has been overlooked in providing an exhaustive education in all aesthetic and technical areas. You'll be in full control of your production environment—confident and prepared for anything.

#DIDTMPCOMMA Comprehensive Course **389.95**

#DIDTMPCOMMP 25 DVD, Command-Plus Course... **439.95**



F3D-XW / F3D-SRW

Test Charts for 3-D Cinematography

Fairburn 3-D - Maxi

- Precise Setup and Post Processing
- Horizontal / Vertical Alignment Spires
- High Contrast Focus Fans in Corners • Zoom Rings
- Right and Left Words
- Hexagonal ChromaDuMonde Reference



F3D-XW Fairburn 3-D - Maxi #DSF3DXW **1879.95**

F3D-SRW Fairburn 3D (Senior) #DSF3DSRW **1294.95**

HCE / CK4 Handy Test Charts

HCE (Handy Camette):

5-step grayscale, 6 primary colors, CamWhite

- Active area—10 x 6", 25.4 x 15.24cm

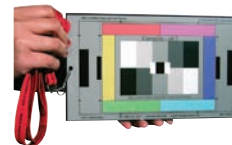

CK4 (CamBook-4):

6 primary colors, 11 step grayscale, Multiburst lens resolution test pattern, Backfocus Star, CamWhite

- Active Area—11 x 6.18", 27.94 x 15.69cm

HCE Handy Camette Test Chart #DSHCE..... **144.95**

CK4 CamBook-4 Text Chart Folder #DSCK4..... **499.95**

FBC / FBS / FBP / FB12+4

Professional Camera Test Charts

These patented FrontBox series test charts are essential to optimize tonal reproduction and create richer, more accurate imagery, especially in HD productions. Align for color, grayscale, aspect ratio, and focus. Completely waterproof.



FBC 11-step grayscale and backfocus star #DSFBC.... **119.95**

FBP 6 primary colors, 11-step grayscale, 4 skin tones #DSFBP **267.95**

FBS 6 primary colors, 11-step grayscale #DSFBS **244.95**

FB12+4 12 primary colors, 11-step grayscale, 4 skin tones #DSFB12P4 **349.95**

ChromaDuMonde 12+4/28R

Professional CamAlign Chip Charts

The patented 12+4 / 28R CamAlign color calibration charts are excellent for evaluating and calibrating a camera's color and gamma. They should be recorded with every scene and setting change to ensure consistency and accuracy in your work, and as a baseline reference in post-production.



12+4 Junior- 10 x 17" (HxW) #DSCDM124J **754.95**

28R Standard 13.7 x 21.3" (HxW) #DSCDM28RST **1049.95**

Pro Camcorder Cases



CC-191 / CC-192 / CC-193

Lightweight, TST (Thermo-Shield-Technology) protected compact cases for Mini HDV/DV camcorders. The customizable Modi-Vers System allows you to create compartments that meet your requirements.

- CC-191 15.7 x 7.8 x 7.8" #KACC191 **80.39**
- CC-192 19.89 x 7.87 x 7.87" #KACC192..... **91.79**
- CC-193 21.2 x 8.6 x 10.2" fits XH-A1, HVX200, Sony Z1/V1 #KACC193 **111.89**



CC-195 / CC-196 / CC-197

Lightweight, TST protected cases with internal aluminum top frame, which provides extra protection for viewfinder and mic. Contoured interior with thick padding and six layers of protection.

- CC-195 22.8 x 11.0 x 11.0" fits Canon XL-H1 or JVC GY-HD110 #KACC195 **140.59**
- CC-196 23.6" x 11.4" x 11.0" fits Canon XL-H1, JVC GY Series or Sony PMW-EX3 #KACC196..... **160.69**
- CC-197 26.4 x 11.4 x 11.4" fits Canon XL-H1 or JVC GY-HD200/250 fully accessorized #KACC197 **172.19**

CCC-10A / CCC-1A / MCC-2A

Camcorder cases that provide the ultimate protection for full-sized camcorders with attached lens and batteries. Offering quick access, watertight zippers and padded accessory pockets. Optional DTS Insertrolley.



- CCC-10A 22.4 x 10.6 x 10.2" #KACCC10A **243.89**
- CCC-1A 27.2 x 11.4-7.4 x 11-9.8" #KACCC1A..... **399.49**
- MCC-2A 28.3 x 11.4-7.4 x 12.6-9.8" #KAMCC2A..... **162.95**



ONE MAN BAND SERIES

Pro Camcorder Shoulder Case

The One Man Band -75 is the ultimate mobile production solution for the solo videographer that does it all. The main internal compartment is designed to be customized using the provided dividers and detachable pouches. It will fit numerous set up configurations to hold, protect and organize all the necessary equipment in just one cohesive bag. Various configurations will allow you to take camcorders such as the Sony EX1,Z1, Panasonic HVX200, Canon A1/G1 and similar. The camera will fit with mattbox, external mic and mini light attached while your headphones, laptop, accessories, batteries, and small monitor fit in the various divisions and compartments within the bag. A video tripod can be attached to the outside of the bag.



- OMB-75 22 x 15 x 18.9" #KAOMB75..... **246.79**
- OMB-72 19.7 x 9.8 x 16.3" #KAOMB72..... **177.89**
- OMB-74 19.7 x 13.6 x 16.9" #KAOMB74..... **212.29**
- OMB-77 27.6 x 16.1 x 18.9" #KAOMB77 **299.95**

HB-205 / HB-207 Pro Hiker Backpacks

These backpacks fit HDV/DV camcorders such as Canon XH-A1/G1, Sony Z1/V1, Panasonic HVX200, and similar. TST protection and ergonomic harness provide lightweight, comfortable carrying for the long haul. HB-207 features an additional top compartment and rear laptop pocket (up to 17").



- HB-205 18.1 x 11.8 H 6.2" #KAHB205..... **269.90**
- HB-205 22.4 x 11.8 H 7.0" #KAHB207..... **215.19**

R-106 Rucksack

The R-106 Rucksack is cleverly designed to hold camcorders such as the Sony EX1, Panasonic HVX200, Canon A1/G1 and similar sized models. Additional accessories such as media, batteries, filters, charger, cables etc. can be stored in the surrounding compartments, the spacious arched lid compartment.(optional trolley not included).



- R-106 14.2 x 13 H 21.3" #KAR106..... **299.89**

MC-61 GDC Multi Case



Multi-purpose case designed for HDV/DV camcorders with a matte box attached. Ample room for many accessories and a laptop (up to 17"). TProtected by TST (Thermo-Shield-Technology) and well-padded sides. Ergonomically designed, it has multiple carrying possibilities.

- #KAMC61 19.3 x 8.3 x 10.6"..... **Call**

LS-36 / LS-46 / LS-54

Light Stand Cases



The LS light stand bags are light and compact carrying and working solution light stands. Kata's signature TST protection is featured on each end of the bag for extra protection where it counts.

- LS-36 36.8" x 10.8" x 7.1" #KALSB36..... **43.09**
- LS-46 46.3" x 10.8" x 7.1" #KALSB46..... **48.79**
- LS-54 52.8" x 10.8" x 7.1" #KALSB54..... **54.59**

TRIPACTION-41 / 42 Tripod Carrier

The Tripoaction is the perfect case for medium-sized field tripods with a variety of head sizes. An extra-wide, zippered opening extends the entire length for quick access. Includes fabricated Nycore with fluorocarbon-based, water-repellent finish on the outside and three layers of polyurethane coating on the inside.



- Tripoaction-41 34.6 x 7.7 x 7.7" #KATS41..... **134.95**
- Tripoaction-42 42.5 x 7.7 x 7.7" #KATS42..... **174.89**

PALMS-1 / 2 / 3 Advanced Lighting Cases

Uniquely shaped, double-arched, butterfly-lid lighting cases carry a large variety of accessories and sensitive equipment, such as lights, stands, power supplies, cables. The PALMS cases cannot cave in, and include a DTS Insertrolley.



- Palms-1 30.7 X 7.5 X 8.3" #KAP1 **335.95**
- Palms-2 36.6 X 7.9 X 8.7" #KAP2Q..... **379.95**
- Palms-3 44 X 11.8 X 8.7" #KAP3Q..... **389.95**

KT-OC-84 / 88 / 97

Pro Organizer Cases

Lighting cases with TST and a honeycomb reinforcement that provide ultimate protection. The main compartment fits 3 to 4 lights and up to 4 stands. A secondary compartment holds cables, gels, plus other accessories.



- KT-OC-84 18.1 x 13.3 x 6.2" #KAOC84..... **249.90**
- KT-OC-88 29.9 x 11.0 x 8.6" #KAOC88..... **299.99**
- KT-OC-97 34.6 x 12.6 x 9.4" #KAOC97..... **516.99**



PCUB-HD HDV U-Bag

With its padded, U-shaped opening, this case allows for quick removal and insertion of your camcorder. Designed to be a custom-configured protective case to hold fully equipped camcorders with accessories up to 21" long, such as the Canon XL-H1 or Sony PMW-EX3. Features 3 removable dividers, tripod straps, accessory pockets, and a dual padded strap.



#PEPCUBHD 21.2 x 8.2 x 11.8" **239.95**

PC302

Deca Camera Rollpak

The Rollpak is a 2-in-1 professional camera trolley/backpack that offers a host of industry leading advantages such as: exchangeable logo frame, interior strap to hold Petrol Bags internal LED lighting system (which can be purchased separately), Padded rear pocket holds computer with up to 17" screen, carrying backpack system with built-in wheels and trolley.



#PEPC302 18.5 x 12.6 x 5.9" (LxWxH)..... **274.95**

PA1001

Snaplock Trolley System

This handy external wheel and tote assembly is the ideal way to comfortably transport many of the new Deca bags. When not in use folds into compact lightweight package for easy storage and transportation, attached to special connecting brackets in the base of the bag.



PA1001 Snaplock Trolley System
#PEPA1001 **59.95**

PMCK-1N / PC300 Deca

MiniDV Camcorder Shell Camera Backpack

Ergonomically contoured, comfortable backpack is designed as a versatile carrier for MiniDV and HDV camcorders. Multi-layered walls of shock-absorbent foam padding provide gear with maximum protection. Removable dividers, accessory pouch, and a zippered base store accessories.



• Backpack with tripod holder design
#PEPMCK1N 19.3 x 11.4 x 7.6" **144.95**

Deca Mini Camporter PC201/PC202

Pro Bag for Medium Size Camcorders

Designed to fit most popular standard and high-definition pro camcorders.



- Lightweight with extra protection
- Removable dividers for custom configuration
- Sturdy exterior straps

PC201 16.4 x 8.3 x 9.45" (LxWxH) #PEPC201 **129.95**
PC202 18.9 x 9.8 x 9.7" (LxWxH) #PEPC202 **144.95**

Petrol Bags Deca Dr. Bags

The new Deca Dr. Bag is packed with industry leading new features like: plastic exchangeable logo frame that lets user add their own logo, removable internal LED lighting system that illuminates bags interior and content, removable shock-resistant molded AbsorbaPad and twin connecting brackets on the bottom for quick connection of Snaplock wheel and trolley system.



PC001 13.4 x 7.1 x 8.9" (LxWxH) #PEPC001..... **119.95**
PC002 15.4 x 8.3 x 10.2" #PEPC002..... **149.95**
PC003 17.32 x 9.25 x 8.2" #PEPC003..... **159.95**
PC004 22.6 x 10 x 7.9" #PEPC004..... **244.95**
PC005 26 x 10.63 x 9.5" #PEPC005..... **286.50**
PC006 29.13 x 11 x 9.5" #PEPC006..... **309.95**

PWB-HDV / PWR-HDV

Lightweight HDV Camera Wingbag

Protect your Sony HDV and Panasonic DVX series camcorders. Multi-layered foam wall construction with reinforced panels, water-resistant Cordura fabric, and heavy-duty dual-directional zippers.



The PWR-HDV has a telescoping tote bar and inline skate wheels.

PWB-HDV 17.7 x 6.9 x 6.1" (6.7 lbs) #PEPWBDHV **169.95**
PWR-HDV 18.3 x 6.3 x 9.6" (8.9 lbs) #PEPWRHDV ... **199.95**

Deca U-Bag Series Ultrawide Cases

U-BAGS offer an ultrawide "U" opening for insertion of a camera without disturbing the viewfinder, mic, shade, or matte box. The new design has industry leading new features such as: exchangeable logo frame for customer's customization, removable internal LED lighting system, removable shock-resistant molded AbsorbaPad and twin connecting brackets on the bottom for quick connection of Snaplock wheel and trolley system.



PC102 24 x 7.9 x 12.2" #PEPC102..... **314.95**
PC103 28 x 8.3 x 12.4" #PEPC103..... **324.95**

Deca PC301 / PC303 / PC304

Hiker & Backpacks

Petrol Bags backpacks are ideal for "on-the-move" camera work when travel and hiking to location is required. These new camera/laptop backpacks feature a host of industry leading advantages such as:



- Ergonomic backpack system for correct weight distribution and greater carrying comfort.
 - Enough room to hold camera without disturbing the viewfinder
 - Removable dividers • Back pocket holds up to 17" laptop
 - Folded cover protects bag and contents from rain, dust and sun
- PC301** 17.7 x 11.8 x 5.3" #PEPC301..... **224.95**
PC303 21.3 x 12.8 x 8.68" #PEPC303..... **Call**
PC304 Deca Broadcast Trailer #PEPC304 **399.95**

PPSB-15 Petrol Pillow Staybag

The two-in-one camera support solution. This ingenious new duffel-style carrier is ideal for transporting a camera comfortably and safely to location, and it also provides a steady mounting solution



for extreme shooting scenarios (such as on a moving car, a rock, or on a highly angular surface) where a tripod is not possible.

PPSB-15 28.3 x 9.45 x 11" #PEPPSB15..... **99.95**

Lighting Cases

PLC-3 / PLC-4 / PLC-5

Hard Shell Light Cases

Portable hard-shell cases with honeycomb-reinforced frame, dividable interior. Accommodate 1-4 heads.



- Water-resistant fabric
- Scooter wheels

PLC-3 26.7 x 12.6 x 10.03" #PEPLC3 **279.95**
PLC-4 30.7 x 12.59 x 10.03" #PEPLC4..... **349.95**
PLC-5 35.8 x 14.6 x 10" #PEPLC5..... **194.95**

PCSB-2

Petrol C-Stand Rolling Bag

The "C-Stand" rolling bag can carry up to 2 "C-Stands" or grip stands. The C-Stand model must be in two parts.



- Internal nylon binding straps hold stands in place
- Rugged front and rear handgrips enable easy lifting from a shelf or back compartment of a car
- U-grip ergonomic interlock carrying handle
- Built-in heavy duty wheels and trolley

PCSB-2 48 x 9.0 x 6.0" #PEPCSB2..... **99.95**



PA Series

Camcorder LCD Monitor Hoods



Reduce flare and glare of light on the LCD screen. Folds flat for easy storage.

- PA1007** Mini Hood for 2.5" Monitors #PEPA1007 **14.95**
- PA1008** Mini Hood for 2.7" Monitors #PEPA1008 **19.95**
- PA1009** Mini Hood for 3.5" Monitors #PEPA1009 **19.95**

Revolutionary Rain Covers

Ingenuous one-piece design makes the cover extremely easy to install while shooting. Constructed largely of transparent polyurethane (TPU) for maximum visibility. Quick and easy access to all camera features, such as battery and panels. "Exterior 6" ABS track allows for addition of mini light while the raincover is in use. Front cover section of ripstop fabric and TPU that attaches to cover and provides extra protection and still allows clear view of tally light



- PR401** Deca Raincover for RED ONE #PEPR401 **159.95**
- PR405** for mini DV/HDV video cameras #PEPR405 **84.95**
- PR410** for Sony PMQ-EX1 and HRV-Z7 #PEPR410 **109.95**
- PR415** f/Sony PMW-EX3 & JVC GY-HD200 #PEPR415. **136.49**
- PR425** f/Sony PDW-700 & AJ-HPX2700 #PEPR425 .. **161.95**

PM801 / PM802 / PM803 / PM804
Deca LCD Monitor Bags

Inside the main compartment, the monitor is cushioned by multiple layers of densely padded fabric. Once on location, the bag's side panel opens into a sturdy one-piece top hood that aids shading and viewing. Multiple vents for optimum cooling. Exterior side accessory pocket for extra storage, top carrying handle, optional ergonomic padded shoulder strap, and raincover.



- PM801** For Sony LMD-940W. 8 X 8 X 7" #PEPM801 . **159.95**
- PM802** For 4.5-7.5" LCD monitors 9.1 X 6.3 X 3.3" #PEPM802..... **114.95**
- PM803** For 9" monitors 9.1 X 9.1 X 3.9" #PEPM803 .. **139.95**
- PM804** For 17" monitors 17.3 X 4.7 X 12.2" #PEPM804. **239.95**

PIAB

Inflatable Airline Bag

Designed specifically for boarding with a full-size broadcast camera with viewfinder and lens.

- Fits Full-size Broadcast Video Camera • Cordura and Ballistic Nylon Exterior
- Removable Internal Inflating System
- Side pocket with Coiled Inflating Pipe • Two Straps with an Overlapping Grip • Removable Nylon Shoulder Strap
- Nylon Carry Pouch • 25.2 x 11.8 x 11.4" (LxWxH)



PIAB Inflatable Airline Bag #PEPIAB **Call**



Pro Camcorder Protection

DVG-51 / 52 / 53 / 54 / 57
Pro Camcorder Guards

Revolutionary guards that duplicate exact camcorder design and provide overall protection while maintaining all working functionality. Safeguard camera from knocks, scratches, dust, and dirt.



- DVG-51** For Panasonic HVX200 #KADVG51 **131.99**
- DVG-52** For Sony Z1, FX7 #KADVG52 **131.99**
- DVG-53** For Canon XL-H1, XL2 #KADVG53 **131.99**
- DVG-54** For JVC GY-HD110/200/250 #KADVG54 **131.99**
- DVG-57** For Canon XH-A1/G1 #KADVG57 **131.99**

RC-1 / 10 / 11 / 13 / 14 / 15 / 17 / HD-3
Pro Rain covers for ENG and HD Camcorders



- RC-1** f/full-size camcorders #KARC1 **134.89**
- RC-10** f/medium-size pro camcorders #KARC10 **111.89**
- RC-11** f/Canon XL-H1, XL2 w/o accessories #KARC11 .. **67.19**
- RC-12** Compact Rain Cover for Sony EX3 and Canon XL-H1 #KARC12..... **67.19**
- RC-13** f/Canon GL2, Panasonic DVC30, Sony HC1 #KARC13..... **63.19**
- RC-14** f/Canon XH-A1/G1, Pan. DVX100, Sony PD170 #KARC14 **74.59**
- RC-15** f/Sony Z1, FX7, Panasonic HVX200 #KARC15... **84.95**
- RC-17** for small handheld camcorders #KARC17..... **25.89**
- HD-3** f/full-size HD camcorders #KARCHD3 **166.39**

CG-SERIES Pro Camcorder Gloves

Tailored, fitted black neoprene body gloves protect your camera from extreme elements. Pull-to-open system allows quick access. Rain hood included.



- CG-1** for Ikegami HL V55, Sony BVW D600, 400, 300 & 200, Thompson LDK-491, LDK-391 camcorders #KACG1 .. **294.95**
- CG-2** for Sony DNW-7, DNW-7P, DNW-90, DNW-9WS and 90WSP Camcorders #KACG2 **294.95**
- CG-3** for Sony DVW-700, DVW-707, 709, 790WS, HDW-700, HDW-750, HDW-790 & MSW-900P #KACG3 **294.95**
- CG-4** for Sony DSR-570; JVC GY-DV5000, Panasonic AG-DVC200 and Similar Size Camcorders #KACG4..... **262.95**
- CG-6** for Panasonic AJ-D200, AJ-D210, AJ-D215, AJ-D300, AJ-D400, AJ-D410, AJ-D610, AJ-D700, AJ-D800, AJ-D810, AJ-D910, AJ-HDC20, AJ-HDC27, AJ-PD900, AJ-SDC915, AJ-SDX900 and Hitachi Z-V1A Camcorders #KACG6 .. **293.50**
- CG-9** for Sony PDW-510P, PDW-530P (XDCAM) Camcorders #KACG9..... **294.95**
- CG-10** for JVC GY-DV Camcorders #KACG10..... **262.95**
- CG-11** for Panasonic Varicam and DSX #KACG11..... **262.95**
- CG-12** for Panasonic SPX (P2 series) #KACG12 **328.99**
- CG-13** for Sony DSR400 or DSR 450 #KACG12..... **328.99**



CBA SERIES Camcorder Body Armor

Custom-fit protective camera cover with triple-layer material that is water, ordor and stain resistant. All-new material feels soft but is as durable as 1000-denier Cordura®. Quick-Slick™ rain cover is included and stores in the Camera BodyArmor™



- for Canon XF-305 and 300 #POCBAXF305 **271.95**
- for Sony HXR-NX5U #POCBANX5 **Call**
- for Sony PDW-EX1 and EX1R #POCBAEX1R..... **264.95**
- for Sony PDW-EX3 #POCBAEX3 **284.95**
- for Canon XHA1/G1 #POCBAXHAG1 **235.79**
- for Panasonic AG-HVX200 #POCBAHVX200 **235.79**
- for JVC GY-HD250 #POCBAHD250..... **264.99**
- for Sony PDW-F330/350/F355 #POCBAF350..... **424.95**
- for Panasonic AG-HPX500 #POCBAHPX500..... **419.95**
- for Panasonic PDW530 #POCBAPDW530..... **434.95**

Compact HD Rain Slickers

Custom-fit rain-protection. Flaps, vinyl windows and zippered openings provide optimum ease of operation. Works on a tripod or handheld. Made from 3-ply nylon, Fabuthane® fabric with soft Tricot®-backing that protects against temperature changes and provides excellent rain protection.



- #PORSNX5 for Sony HXR-NX5U..... **Call**
- #PORSEX3 for Sony PMW-EX3..... **196.39**
- #PORSVX100 for Panasonic DVX-100..... **224.95**
- #PORSHVX200 for Panasonic AG-HVX200..... **164.89**
- #PORSHD100 for JVC GY-HD100U/110U..... **189.95**
- #PORSEX1 for Sony PMW-EX1 **164.89**
- #PORSXHAG1 for Canon's XH-A1 and G1 **164.89**



The desertSuit is the latest feature in camera covers. This suit protects your camera from dust and water, it is made of the same noiseless material as the wetSuit and because the cover is manufactured in a white reflecting material, it minimizes the heating effect of the sun.



- DS HDR Z1/Z5/FX1** DesertSuit #CADSHDRZ..... **174.95**
- PMWEX3** for Sony PMW-EX3 #CADSPMWEX3 **174.95**

SNOW COATS

This highly insulated, thermal camera jacket keeps your camera, batteries, lens and hands warm at extremely low temperatures. Built-in heat packs help to maintain the high internal temperature for more than 6 hours.

- SC I** Snow Coat for camcorder to 25.9" #CASC1 **349.95**
- SC II** Snow Coat for camcorder to 29.5" #CASC2 **353.95**



CS-DV Series

Compact HD Camera Cases

Compact HD Carrying Cases protect and organize cameras and essential accessories.

The bottom panel is reinforced with rigid plastic, thick foam, and a new layer of anti-skid material. Padded pouches and camera cradle included.



- CS-DV1U** 12 x 7.5 x 7.0" #POCSDV1U..... **70.19**
 - CS-DV2U** 14 x 7.0 x 7.0" #POCSDV2U..... **85.99**
 - CS-DV3U** 18 x 7 x 8.5" #POCSDV3U..... **116.76**
 - CS-DV4U** 21 x 7 1/2 x 10" #POCSDV4U..... **164.89**
- Also available in Black material**

DVO-1U / DVO-2U / DVO-3U

Digital Video Organizer

A rigid frame provides an extra level of protection. Includes 8 interior components that allow you to create a custom protective environment

for your camera and accessories. Soft suede shoulder strap included. Available in Black or Blue



- DVO-1U** Camcorders to 16" Long #PODV01U..... **196.39**
- DVO-2U** Camcorders to 17" Long #PODV02U..... **204.69**
- DVO-3U** Camcorders to 16" Long #PODV03U..... **283.09**

CTC-1 / CTC-2 / CTC-3 / CTC-4

Traveler Camera Cases

Mid-size camera case with viewfinder protection. Reinforced layers of lightweight plastics and thick foam protect your camera and accessories. New anti-skid bottom adds an extra layer of protection against water and dirt. Suede strap included. Available in blue or black.



- #POCTC1 22.5 x 7.5 x 10.2" (LxWxH)..... **188.89**
- #POCTC2 20.25 x 6.5 x 10" (LxWxH)..... **196.79**
- #POCTC3 f/Camcorders up to 22" Long..... **204.29**
- #POCTC4 22 x 6.5 x 10.5"..... **324.95**

CAR-1 / CAR-2 / CAR-3

Cargo Cases

Cargo cases with durable, 1000-denier Cordura exteriors, rigid frames, and dividable main compartments with 3 large outside pockets. Protect and organize your equipment.



- CAR-1** 13 x 8 x 10" #POCAR1..... **159.99**
- CAR-2** 18 x 8 x 10" #POCAR2..... **165.19**
- CAR-2K** Cold Weather Version #POCAR2K..... **209.95**
- CAR-3** 21 x 8 x 10" #POCAR3..... **180.59**
- CAR-3K** Cold Weather Version #POCAR3K..... **Call**

CC-HD1 / CC-235

Quick Draw Pro Camera Cases

These lightweight, padded quick-draw cases feature a top-loading design and a protective aluminum viewfinder guard. They feature 2 trim exterior pockets and a dual-purpose, expanding rear pouch to accommodate a larger camera battery.

- Includes a leather handle and heavy-duty, non-slip shoulder pad



- CC-HD1** 29 x 11.5 x 12" #POCCHD1..... **359.95**
- CC-235** 25 x 13.5 x 10" #POCC235..... **389.95**

RB-1 / RB-2 / RB-3 / RB-4

Run Bags

Carry and protect all types of gear. The main compartment is foam-padded with a foam-padded, rigid bottom panel. Removable divider-kit

interior allows for custom protection. Suede shoulder strap included. Available in blue or black.



- RB-1** 13.25 x 6.5 x 8" (LxWxH) #PORB1..... **159.95**
- RB-2** 13.25 x 6.5 x 8" (LxWxH) #PORB2..... **149.09**
- RB-3** 25 x 7 x 9.5 x 8" (LxWxH) #PORB3..... **182.95**
- RB-4** 30 x 8 x 11" (LxWxH) #PORB4..... **180.99**

BK-2N Camcorder Backpack

A full 8" deep, this backpack is ideal for compact HD cameras and DSLR cameras with matte-boxes. New load-bearing straps make heavy loads comfortable to carry. 10 interior components let you create custom protective environment. Padded laptop pocket holds up to 17" laptop.



- BK-2N** 18.5 x 12.5 x 20" (LxWxH) Blue #POBK2N..... **353.95**
- BK-2NR** 18.5 x 12.5 x 20" Black #POBK2NR..... **353.95**

TLQ / TS Series Tripod & Lighting Cases

The Quick Tripod/ Light case features a top-opening system that hinges wide open for fast loading and removal of tripods or lighting set-ups. The Tripod Shellpack with Off-Road Wheels is available at reduced pricing! Roll your case smoothly over almost any surface.



- TLQ-28XT** 28 x 8.0 x 8.5" (LxWxH) #POTLQ28XT..... **220.09**
- TLQ-35** 35 x 9 x 7" (LxWxH) #POTLQ35..... **227.89**
- TLQ-39XT** 39 x 9.0 x 8.0" (LxWxH) #POTLQ39XT..... **236.29**
- TS-41BOR** 41 x 12 x 9" (with wheels) #POTS41BOR..... **389.95**
- TS-46BOR** 46" x 12" x 9" (w/wheels) #POTS46BOR..... **393.50**

PB-IC-SERIES

Safeguard Field Production Vault with Removable Cases

Watertight, unbreakable hard case shells with removable Porta-Brace interior carrying case.



- #POPB2500IC 17.7 x 12.6 x 6.9" (LxWxH)..... **274.95**
- #POPB2600IC 18.9 x 14.2 x 7.9" (LxWxH)..... **319.95**
- #POPB2650IC w/wheels 18.9 x 14.2 x 9.5" (LxWxH)..... **359.95**
- #POPB2750IC w/wheels 21.9 x 18 x 10.2" (LxWxH)..... **399.50**

PB-Series Vault Cases

Unbreakable, lightweight and watertight. Available with or without wheels. Cubed foam interiors are standard, or upgrade to padded Divider-Kit or removable soft case interiors.



- PB-2500F** 17.7 x 12.5 x 7" #POPB2500F..... **86.19**
- PB-2550F** 20.1 x 11.2 x 7.9" #POPB2550F..... **133.59**
- PB-2600F** 18.9 x 14.2 x 9.5" #POPB2600F..... **99.99**
- PB-2550LSO** Laptop Sleeve #POPB2550LSO..... **70.39**
- PB-2650F** 18.9 x 14.2 x 9.5" #POPB2650F..... **149.39**
- PB-2700F** 21.5 x 17.75 x 7" #POPB2700F..... **153.95**
- PB-2750F** 21.9 x 18 x 10.2" #POPB2750F..... **180.99**
- PB-2850F** 29.3 x 20.65 x 18.01" #POPB2850F..... **319.95**

PC-111 / PC-202 / PC-333

Production Cases

The Production Cases are durable, lightweight, and can be positioned to accommodate numerous combinations of cassettes, batteries, mics, cables, filters, wireless mics and other audio equipment.



- PC-111** Medium Production Case - for Audio and Video Accessories (Blue) #POPC111..... **234.99**
- PC-111B** Med. Production Case (Black) #POPC111B..... **249.95**
- PC-202** Med. Production Case (Blue) #POPC202..... **234.95**
- PC-202B** Med. Production Case (Black) #POPC202B..... **234.95**
- PC-333** Production Case (Blue) #POPC333..... **259.49**
- PC-333B** Production Case (Black) #POPC333B..... **289.95**

MO Series Lightweight Field Monitor Cases

Protect your flat-screen monitors and improve screen visibility. Custom-fit padded protection and a fold-out visor that shields the screen from sun glare. Soft suede shoulder strap included.



- MO-9L2** f/Sony PVM-9L2 or PVM-9L3 #POM09L2..... **Call**
- MO-LH80W** f/Panasonic BT-LH80W #POMOLH80W..... **156.99**
- MO-70XP/651** f/Marshall V-LCD651ST & V-LCD70XP #POMOLCD84..... **159.95**
- MO-LMD9050** f/Sony LMD-9050 #POMOLMD9050..... **156.99**
- MO-LH1700** f/Pana. BT-LH1700W #POMOLH1700..... **259.95**
- MO-LMD940W** f/Sony LMD-940 #POMOLMD940W..... **Call**
- MO-LH1700G** Fits most 17" #POMOLH1700G..... **262.95**
- MO-1923** Fits most 20-25" monitors #POMO1923..... **386.39**



AMRE SERIES HARD CASES

Waterproof High-Performance Cases

HPRC are premium Italian designed cases that give you the confidence to send your equipment into even the most severe conditions. That's because HPRC shells are injection molded using an advanced patented plastic that creates a light-weight high-strength barrier between your protected items and the outside elements. HPRC protection meets ATA 300 specifications for transit cases as well as rigorous standards for military use. Unbreakable hard resin-shelled waterproof black transit cases have a cubed "pick-and-pluck" foam interior, soft-grip handle, and air pressure release valve. The "WF" series has smooth-gliding wheels.

#HP2500FB	17.72 x 12.60 x 6.89"	101.49
#HP2600FB	18.90 x 14.17 x 7.79"	115.49
#HP2600WFB	With wheels (14.17 x 19.05 x 8.58")	152.19
#HP2700WFB	With wheels (18.11 x 21.85 x 10.08")	174.59



PEARSTONE

DVC-777 / HDC-1010W

Camcorder Cases

Camcorder case specifically designed for the most popular professional HDV/MiniDV/DVCPRO HD handheld camcorders. Removable flexible dividers allow for custom case configuration. Accommodates camcorder with a matte box or accessory lenses attached.



DVC-777	15-3/4 x 8-1/4 x 8-3/4" (LxWxH)	#PEDVCB. 79.95
HDC-1010	24 x 13 x 10" (LxWxH)	#PEHDC1010W..... 179.95



CB-01 Production Bag

The CineBags CB-01 Production Bag has numerous pouches for carrying a camcorder and accessories in the field. It is made from reflective waterproof material, and has a reinforced bottom with padding on all sides, as well as a large padded shoulder strap.



- 4 removable pouches on outside of case
- 4 clear mesh pouches with zipper on inside of lid

#CIBC01	18 x 11 x 9" (LxWxH)	182.99
---------	----------------------	-------	---------------

CB-25A / CB-25DC

HD LT Backpacks

CB series backpacks are designed to carry camcorders like the Sony PDW-EX1, HVR-Z1U, Panasonic HVX-200, Canon XH-A1, together with laptops of various sizes, tripod and accessories. Waterproof, reflective fabric, buckles, and pockets on both sides.



The CB-25 holds a computer up to 17".

CB-25	Int. Dim: 10.5 x 16 x 8.5"	
(Black/Gray w/Blue)	#CICB25A.....	187.99
CB-25DC	(Camouflage)	#CICB25DC..... 189.99

VariZoom

VZ-B20 Custom Video Bag

Reinforced, thick-padded, custom-fitting, with strong rectangular design. Allows convenient packing and stacking of your video camcorder and accessories. Four exterior compartments with quick access.



• 2 accessory pouches	• Adjustable interior	
#VAVZB20	18 x 8 x 7" (WxHxD) 94.95

CB-30 Camera Daddy Bag

Black and Gray with Orange Webbing is a 600 denier waterproof Ripstop nylon bag with heavy-duty padding.



- Fits Camcorder and Accessories
- Heavy-duty Padded Interior
- Six Removable Dividers
- Many Interior and Exterior Pockets
- Dual Padded Carrying Handles
- Removable Shoulder Strap

CB-30	25 x 15 x 10" (WxDxH)	#CICB30	213.99
--------------	-----------------------	---------	-------	---------------



CB116X9 / CB216X9

Grab & Shoot Camcorder Bags

Quick-opening camcorder bag made to hold (depending on its size) Sony HVR-Z1U, Panasonic AG-HVX-200, JVC GY-HD100U, or Canon XL-H1 3 CCD professional HDV camcorders securely in place with a mattebox attached. Heavy-duty waterproof Cordura exterior with padded equipment protection on all sides. Two exterior side pockets and two interior pockets.



CB116X9	Interior Dimensions: 23 x 11 x 10"	
#16CB116X9	199.95
CB216X9	Interior Dimensions: 27 x 11 x 11"	
#16CB216X9	219.95



317
Tripod/Lightstand
Multi Hard Case

- Fits Tripods and Light Stand up to 46"
- Molded Polyethylene with Foam
- 2-piece Case Slides Together
- Molded Carry Handle
- Molded Pull Handle on End
- Interior Dimensions 10 x 48" (Dia x L)
- 2.5" In-line Skate Wheels



#317	Tripod/Lightstand Multi Hard Case	
#MIMHC	249.95



PTC-2 / PTC-3 Tripod Cages



Air transportable, hard shell, rigid aluminum framework, thermo-formed side and bottom panels and 2 zippered pockets outside. Expansive top flap opening for easy access.

PTC-2	with Wheels 37.8 x 7.5 x 7.5"	#PEPTC2	Call
PTC-3	with Wheels 41 x 8.7 x 8.7"	#PEPTC3	Call



PRO V-1 / PRO V-2

Video Bags

- Canvas and Nylon Exterior
- Heavily Padded Interior
- Moveable Dividers and Inserts
- Pockets for Accessories
- Removable Handle
- Removable Shoulder Strap
- Made in USA.



Pro V-1	Interior Dimensions: 14.5 x 7.0 x 7.0"	
#DOPROV1	199.99
Pro V-2	Fits Camcorders up to 19" Long	
#DOPROV2	259.99



TP-0936L / TP-1139WHL

Tuffpak Hard Tripod Case

The Nalpak Tuffpak Diagonal Octagonal hard plastic cases with locks are made from rotationally-molded, cross-linked polyethylene. Each case will hold a tripod snugly at a length of 36 to 41 inches (if the lid is telescoped out). The diameter is appropriate for tripods with up to a 100mm ball. Nalpak tripod cases have a lifetime warranty.



TP-0936L	Tripods 36 to 41" long	
x 9" wide	#NATP0936L 344.95
TP-1139WHL	Tripods 39 to 44" long	
w/wheels	#NATP1139WHL 399.95



521 SERIES Camcorder Lens Controllers

Built onto a small clamp, the 521 series lens controller can be mounted to a wide range of supports—such as pipes, bars, tubes, and flat surfaces—and applied to a variety of applications. Functions include: Record/Stop, Zoom & Focus In/Out, Reversible Zoom Wheel, Power On/Standby.



#MA521P Zoom only for Panasonic..... **179.95**

521Remote Focus and Iris Controller

The 521 PFI is a focus and iris controller specifically designed to operate with the Panasonic AG-DVX100B and AG-HVX200 camcorders.



Focus setting is manual, while iris can be set manually or automatically. Controller has specific label and ring where you can write and rewrite position references for the focus and iris knobs. Designed to work in unison with the 521P and 522P zoom remote for Panasonic.

#MA521PFI **269.95**
521i Remote/522AV Adapter #MA521ILANCAV **169.19**
521Proi LANC Remote/Adapter #MA521PLANCAV ... **234.99**

522P / 523PRO SERIES
 Camera Remote Control Handles

Tripod handle with remote control capabilities for MiniDV camcorders. With one finger you can control the zoom, focus, record, and rec-search functions. Fits 501, 503, 505, 510, and 516 heads.



522P Zoom only for Panasonic #MA522P **328.99**
523Pro LANC Handle Remote and Adapter kit with 522AV adapter #MA523PLANCAV **314.89**

521CFI / 524AX
 ENG Lens Remote Controllers

For Canon, Fujinon and Angenieux lenses, with record start/stop and a speed dial, these controllers allow users to either preselect a zoom speed or change speeds midstream.



521CFI f/Canon and Fujinon lenses #MA521CFI **234.99**
524CFI f/Canon and Fujinon lenses #MA524CFI **339.89**
524AX f/Angenieux lenses #MA524AX **339.95**



ZOE-DVXL Camcorder Lens Controller

Pressure-sensitive and smooth-operating, this controller is contained in a molded rugged polycarbonate housing. Incorporates a separate, precise zoom button to start camera zoom quickly. The zoom rocker has a wide 133° angle of rotation, and the LANC controllers have a dial-in zoom step adjustment.



f/LANC & DVX/HVX Camcorders #BEZOEDVXL **234.95**
 For Sony PDW-EX1 #BEZOEEEX1 **374.95**
 For 8-Pin Fujinon Broadcast Lenses #BEZOEEENG8 **544.95**
 For 12-Pin Fujinon Broadcast Lenses #BEZOEEENG12 **544.95**

FOXI Camcorder Lens Controller

The new Foxi places remote focus and iris control for the Panasonic AG-DVX100B and AG-HVX200 camcorders directly at your fingertips. Make your adjustments quickly, smoothly, and accurately. It has a manual/auto focus switch, and operators can jot pencil marks on the circular white band. Mounts on tripod pan handles or 15mm rods.



#BEFOXI **459.95**

VariZoom

VZ PRO-L / PG-L / PRO-EX
 Remote Variable-Speed Zoom & Focus

The VZ PRO-L and PG-L offer precise, variable speed zoom, manual focus control, and wakeup from standby on any camera with a LANC jack. Crafted from machined aluminum, and built with a sturdy-grip handle.



VZ-Pro-L (LANC) #VAVZPROL **279.99**
VZ-PG-L Compact (LANC) #VAVZPGL **266.09**
VZ-Pro-EX for Sony PMW-EX1 #VAVZPROEX **319.99**

VZ-P SERIES
 Pro Camcorder Lens Controllers



VZ-Pro and VZ-Pistol
 Grip series systems:

#VAVZPGF Deluxe Zoom Control f/8-pin Fujinon lens... **474.99**
 #VAVZPGC Deluxe Zoom Control f/8-pin Canon lens... **382.79**
 #VAVZPGF12 Deluxe Zoom Control f/12-pin Fujinon ... **449.95**
 #VAVZPROC Pro Zoom Control f/8-pin Canon lens **340.29**
 #VAVZPROF Pro Zoom Control f/8-pin Fujinon lens..... **340.29**

Rear Focus Zoom Control

#VAVZPROFCC for 8-pin Canon Pro lens..... **474.99**
 #VAVZFCF for 8-pin Fujinon Pro lens..... **425.29**
 #VAVZFCX Focus Control
 f/Canon XL-1 14x manual lens **474.95**

Zoom and Focus Lens Control Kits

#VAVZSPGC for Canon lenses **Call**
 #VAVZSPGF for Fujinon lenses **Call**
 #VAVZSPGF2 for 1/2" Fujinon lenses **902.50**
 #VAVZSPGF12 for Fujinon 12-Pin lenses **829.95**

VZ-SPG SERIES SYSTEMS

Pro Lens Zoom & Focus Control Kits



For Canon lenses #VAVZSPGC **Call**
 For Fujinon lenses #VAVZSPGF **Call**
 For Small Fujinon lenses #VAVZSPGF2 **902.50**
 For Fujinon 12-pin lenses #VAVZSPGF12 **829.95**

STEALTH / STEALTH LX
 Camcorder Lens Controllers

Experience precision variable-speed control over camera zooms.



Ramp up from slow to fast and then slow again in a single move with this custom-designed "throttle style" zoom.

- Designed f/camcorders with a control protocol
- LED light indicates recording. • StealthLX with frame forward and reverse control and autofocus on/off

#VAVZSTEALTHL for LANC **170.99**
 #VAVZSDVX100 for Panasonic..... **127.59**
 #VAVZSTEALTHL for LANC **170.99**

VZ-PFI / ROCK-PZFI
 ENG Zoom Remote Controls

Compact zoom/focus and iris control for Panasonic's AG-DVX100B and AG-HVX200. The zoom rocker is pressure-sensitive, while the independent knobs for focus and iris may be controlled manually or set to pick up the exiting camera setting automatically.



VZ-PFI Focus & Iris Only #VAVZPFI **127.59**
Rock-PZFI Zoom, Focus & Iris #VAVZROCKPZFI **279.99**

VZROCK SERIES
 Camcorder Lens Controllers

Touch-sensitive rocker control w/record button.

FREE VP-P54 Pouch
 on VZROCK & VZROCKDVX Only



#VAVZROCK f/LANC camcorders **212.69**
 #VAVZROCKDVX f/Panasonic camcorders..... **189.99**
 #VAVZROCKLE Aluminum case f/Control-L **234.95**
 #VAVZROCK f/8-pin Canon lenses **255.19**
 #VAVZROCKF f/8-pint Fujinon lenses **255.19**
 #VAVZROCKEX for the Sony PMW-EX1 XDCAM EX **221.29**



Manfrotto

701HDV Compact Fluid Head

- Designed for compact HD camcorders up to 9.5 pounds
- Updated controls allow a more solid grip and improved fluidity
- Pan-bar rosette and large sliding plate optimize position of camera



Fluid Head	701HDV
Mfg. Item #	MA701HDV
Max Load	9.5 lb
Height	3.7"
Weight	1.8 lbs
Price	149.99

501HDV Pro Fluid Head

- Ideal for small, professional digital cameras • Light but positive fluid movement for smooth control through 360° pan and +90 to -60° tilt
- Teflon friction adjustment to increase drag • Separate pan & tilt locks • Sliding quick-release video plate system



Fluid Head	501HDV
Mfg. Item #	MA501HDV
Max Load	13.2 lb
Height	4.5"
Weight	3.5 lbs
Price	169.81

503HDV Pro Fluid Head

- Supports latest range of pro digital cameras
- Exceptionally smooth control through 360° pan and +90 to -60° tilt • Separate pan and tilt locks • Sliding quick-release video plate system
- Built-in balance spring helps support weight
- Continuous drag adjustment device—0 to max level



Fluid Head	503HDV
Mfg. Item #	MA503HDV
Max Load	17.6 lb
Height	4.5"
Weight	4.4 lbs
Price	338.39

504HD Pro Fluid Head

- PAN fluid drag system for a more ergonomic operation
- 4-step counterbalance system ensures quick set-up and optimal performance • Ball-bearing drag system for precise, smooth movements • Lightweight modern materials for optimum balance of strength and size • 504HLV Pan Handle



Fluid Head	504HD
Mfg. Item #	MA504HD
Max Load	16.5 lb
Height	6.1"
Weight	6.39 lbs
Price	399.90

701HDV Tripod System Kits

701HDV,547BK Kit includes: 547BK Video Tripod, 701HDV Pro Video Mini Fluid Head, Mid Level Spreader and Soft Case

701HDV,055XBK Kit includes: 055XB Aluminum Tripod Legs, 701HDV Pro Mini Fluid Head, with Case

- Designed for birdwatchers and users of compact HD camcorders

System	701HDV,547BK	701HDV,055XBK
Mfg. Item #	#MA701HDV547K	#MA701HD055XB
Max Load	8.8 lb	8.8 lb
Extends to	59.6"	73.82"
Folds to	33.9"	27.76"
Stages/Material	1/Aluminum	2/Aluminum
Weight	6.9 lb	7.39 lb
Carrying Case	Soft Case	Soft Case
Price	299.90	337.89



501HDV Tripod System Kits

501HDV,546BK Kit includes: 501HDV Pro Fluid Head, 546B 2-Stage Aluminum Tripod Tripod, Mid Level Spreader and Soft Case

501HDV,547BK Kit includes: 501HDV Fluid Head, 547BK Video Tripod, Mid Level Spreader and Soft Case

501HDV,535K Kit includes: 501HDV Fluid Head, 535CF Video Tripod, and Carry Case

System	501HDV,546BK	501HDV,547BK	501HDV,535K
Mfg. Item #	MA501HDV546B	MA501HDV547K	MA535501HDVK
Max Load	13.2 lb	13.2 lb	13.2 lb
Extends to	65.1"	60.43"	59.6"
Folds to	31.7"	33.9"	33.5"
Stages/Material	2/Aluminum	1/Aluminum	2/Carbon Fiber
Weight	11.2 lb	8.6 lb	9.4 lb
Carrying Case	Soft Case	Soft Case	Carry Case
Price	474.50	347.79	676.79



501HDV,351MVB2K

503HDV Tripod System Kits

501HDV,351MVB2K Kit includes: 503HDV Pro Fluid Head, 351MVB 1-Stage 2-Section Tripod, Rubber Shoes, Mid Level Spreader and Padded Case

501HDV,755XBK Kit includes: 503HDV Fluid Head, 755XBK Aluminum Video Tripod, and Carry Case

503HDV,535K Kit includes: 503HDV Fluid Head, 535CF Video Tripod, and Carry Case

System	503HDV,351MVB2k	503HDV,755XBK	503HDV,535K
Mfg. Item #	MA351MV503HD	MA755XB503HD	MA535503HDVK
Max Load	17.6 lb	11 lb	17.6 lb
Extends to	62.9"	69.5"	71.8"
Folds to	24"	29.5"	33.4"
Stages/Material	1/Aluminum	2/Aluminum	2/Carbon Fiber
Weight	14.2 lb	9 lb	9.4 lb
Carrying Case	Padded Case	Carry Case	Carry Case
Price	Call	Call	Call



503HDV,755XBK

504HD Tripods Systems

504HD,535K Kit includes: 504HD Pro Fluid Head, 535 3-Section Carbon Fiber Tripod, and Padded Case

504HD,546BK Kit includes: 504HDV Head, 546B 2-Stage Aluminum Video Tripod, Mid Level Spreader and Carry Case

System	504HD,535K	504HD,546BK
Mfg. Item #	MA504HD535K	MA504HD546BK
Max Load	16.5 lb	16.5 lbs
Extends to	72.4"	66.7"
Min. Height	16"	17.9"
Stages/Material	2/Carbon Fiber	2/Aluminum
Weight	8 lb	13.6 lbs
Price	989.95	729.90



504HD,535K

546B / 547B Pro Tripod

Lightweight aluminum professional video tripods.

- Built-in 10mm interface bowl, can be adapted to a 75mm if needed • Rubber shoes guarantee a better grip on smooth floors
- With mid-level spreader

System	546B	547B
Mfg. Item #	MA546B	MA547B
Max Load	44 lb	33 lbs
Extends to	60.6"	55.9"
Min. Height	11.8"	31.3"
Stages/Material	2/Alum	1/Alum
Weight	7.7 lb	5 lbs
Price	424.90	199.95



547B



Manfrotto

516 Pro Video Head Tripod Systems

- Designed specifically for the latest SD and HD camcorders used by documentary and industrial videographers
- Continuous adjustable pan and tilt friction knob (from 0–max level)
- Built-in leveling bubble
- Tandem upper legs, single lower legs, and 100mm claw-ball leveler

System	545BK	516,545GBK
Mfg. Item #	516,545BK	MA516545GBK
Max Load	22 lb	22 lb
Extends to	65.6"	65.6"
Folds to	32.8"	29.1"
Mount	100mm/75mm	75mm
Stages/Material	2/Carbon	2/Alum
Weight	15.2 Lb	12.1 Lb
Carrying Case	MBAG100P	Soft Carry Case
Price	1199.95	1124.99



526 Tripod Systems

- Supports heavy-duty, high-end ENG and EFP cameras
- Adjustable counterbalance spring
- Built-in 100mm half ball
- Most precise fluid drag system, comprised of 3 step settings for low, medium and high drag levels plus a non-drag setting

System	350MVB	545GBK
Mfg. Item #	526MVBKIT	526,545GBK
Max Load	18–35 lbs	35 lbs
Extends to	41.3–65.4"	66.54"
Folds to	43.3"	17.7"
Mount	100mm	100mm/75mm
Stages/Material	Dual/Alum	Dual/Alum
Weight	18.7 lb	15.6 lb
Carrying Case	MBAG100P	MBAG100P
Price	1699.00	1691.99



560B / 561BHDV / 562B Monopods w/Head

Incorporating a fluid cartridge in their base to produce very smooth pans, these monopods with head and quick release are ideal for shooting with compact MiniDV, DVCAM, HDV, and DVCPRO HD camcorders. A great portable solution, they are designed for maximum flexibility and positioning.

System	B0560B Monopod	B0561BHDV Monopod	B0562B Monopod
Mfg. Item #	560B	561BHDV	562B
Max Load	4.4 lbs	8.8 lbs	17.6 lbs.
Extends to	65.5	78.74	76
Folds to	26"	30"	27.16
Mount	1/4-20	3433 (501PL)	3272 (357PLV)
Stages/Material	4/Alum	4/Alum	4/Alum
Weight	1.5 lbs	4.2 lbs	3.15 lbs
Price	131.99	253.79	194.95



Libec

LS & LZ SERIES Aluminum Tripod Systems

- 75mm 3" bowl base (LS-22, 38-2a, 55-2a series)
- Leveling bubble
- 100mm 4" bowl base (LS 60–70 series)
- Single extension tripod design
- Fixed counterbalance system (-80° to +90° tilt)
- Positive locking leg knob

Kit Includes: • Fluid head • 1-stage tripod • Floor spreader • Soft case

System	LS-22DV	LS-38(2a)N	LS-55(2a)N	LS-60M(2A)	LS-70(2A)
SKU#	LILS22DV	LILS382AN	LILS552AN	LILS60M2A	LILS702A
Max Load	9 lbs	17.6 lbs	8–22 lbs	17–28 lbs	13–33 lbs
Extends to	28–58"	22–63"	22–61"	32–62"	22–63"
Stages/Material	2/Alum	2/Alum	2/Alum	1/Alum	2/Alum
Spreader	Floor	Floor	Floor	Floor	Floor
Weight	8.2 lbs	13.5 lbs	11 lbs	14.5 lbs	17.5 lbs
Counter Balance	Fixed	Fixed	Fixed	Fixed	4-Step
Horiz/Vert Drag	Fixed	Fixed	2-Step	2-Step	4-Step
Price	396.89	594.95	894.95	1304.95	2022.95



PROVISTA AIR 18 / 7518
Pneumatic Video Tripod and Fluid Head

Providing rigid support for cameras weighing 2 to 12 lbs, the Airlift features a pneumatic cylinder in its center post to provide smooth and easy height adjustment. Includes the pro FM18 Fluid Video Head with dual handles.

- Pivoting rubber/spike feet
- Double strut top leg sections
- Bubble level

System	PROVISTAIR18	PROVISTA7518B
SKU#	DAPVALFM18	DAPVT75
Max Load	12 lbs	18 lbs
Extends to	61 to 72" (with Lift)	64"
Min. Height	36"	28"
Spreader	Mid-Level	Mid-Level
Stages/Material	2/3 Alum	1/3 Alum
Weight	7 lbs	10.2 lbs
Price	219.95	189.95



Includes Free:
Davis & Sanford
W3 Dolly with
3" Ball Rubber
Wheels

bescor

TH-770 Aluminum Tripod System

Built with sturdy aluminum tandem legs and a 65mm bowl mount, the TH-770 ensures smooth, quick leveling on off-angle shots. The head features a quick-release plate and a counterbalancing spring with 3" of travel distance for improved balance. Folds to 31", includes a padded carrying bag.

System	TH-770
SKU#	BETH770
Max Load	15 lbs
Extends to	60"
Min. Height	30"
Spreader	Mid-Level
Stages/Material	3/Alum
Weight	7 lbs
Price	148.95



CARTONE

H101 / H102 HiDV Tripod Systems

Extremely rugged and versatile, these offer ideal support for DV/HDV cameras weighing up to 11 lbs. Along with a 75mm leveling ball, they incorporate a superb variable counterbalance and continuously variable fluid drag. System also includes spreaders, rubber feet, and soft case.

System	H101	H102
SKU#	CAHIDV	CAHIDV2
Max Load	11 lbs	11 lbs.
Extends to	63"	72"
Folds to	38.0"	32.8"
Stages/Material	1/Alum	2/Alum
Spreader	Mid-level	Mid-level
Weight	10 lbs	10 lbs
Counter Balance	Continuous	Continuous
Horz/Vert Drag	Continuous	Continuous
Price	1039.50	1399.95



Libec

RS SERIES Aluminum Tripod Systems

- 75mm 3" bowl base
- Ideal counter balance
- New drag system
- Head w/Pan Handle
- Low Temperature Characteristics
- Drag mode: Free plus 3 steps. Select torque strength.

Kit Includes: • Fluid head • 2-stage tripod • Floor spreader • Soft case
LED level illumination (RS-450)

System	RS-250	RS-350	RS-450
SKU#	LIRS250	LIRS350	LIRS450
Max Load	13 lbs	20 lbs	8–26.5 lbs
Extends to	21.5–65"	22–65.5"	32–65.5"
Stages/Material	2/Alum	2/Alum	2/Alum
Spreader	Floor	Floor	Floor
Weight	13 lbs	13.2 lbs	14.9 lbs
Counter Balance	Continuous	—	Fixed
Horiz/Vert Drag	2-Step	3-Step	—
Price	974.95	1099.99	1334.99



PRO-TOUCH SERIES
Pro Aluminum Tripod Series

- Illuminated bubble level • Quick-setup Pozi-Loc tripod

Kits include:

- Pro-Touch head with 75mm ball
- Pozi-Loc tripod with spreader and soft case

System	PRO-5AP1F	PR-06-HDVM	PRO10DC
SKU#	VIPRO5	VIPRO6HDVM	VIPRO10DC
Max Load	10 lbs	13.2 lbs	22 lbs.
Extends to		21.11-66.26"	21.11-66.26"
Stages/Material	2/Alum.	2/Alum.	2/Alum.
Spreader		Mid-Level	Floor
Weight	12 lb.	16.1 lb.	18.1 lb.
Counter Balance	Variable	Variable	Variable
Hoiz/Vert Drag	Variable	Variable	Variable
Price	Call	Call	1439.99



FSB 2 / FSB 6 SERIES
Tripod and Fluid Head Systems

- Small, sensitive heads perfectly designed for small to medium-sized SD and HD camcorders
- Frictionless pan and tilt with Sachtler's patented leakproof fluid damping system • 3 drag levels • Snap-& Go sideload mechanism
- 75mm bowl • Sliding camera plate (Touch & Go quick release plate on 0473/0475) • Bubble level (self-illuminated touch bubble on FSB-6)
- All kits come with mid-level spreaders and padded carrying case

Kits also include:

- **#SAFSB2ML1S** (#0272) FSB-2 head, 1-stage aluminum tripod
- **#SAFSB2ML2CFS** (#0275) FSB-2 head, 2-stage carbon fiber tripod
- **#SAFSB6ML2S** (#0473) FSB-6 head, 2-stage aluminum tripod
- **#SAFSB6ML2CFS** (#0475) FSB-6 head, 2-stage carbon fiber tripod

Mfr Model #	0272	0275	0473	0475
Payload Range	0-4.4 lbs	0-4.4 lbs	2.2-13.2 lbs	2.2-13.2 lbs
Extends	37.4-62.2"	30.3-63"	30.3-63"	30.3-63"
Folds to	39.8"	33.1"	33.1"	33.1"
Stages/Material	1/Alum	2/Carbon	2/Alum	2/Carbon
Weight	10.6 lbs	10.8 lbs	11.5 lbs	11.2 lbs
Counter Balance	2 steps	2 steps	10 steps	10 steps
Horiz/Vert Drag	3+0	3+0	3+0	3+0
Price	754.00	969.99	1494.95	1574.95



FSB4 & FSB8 SERIES
Tripod Systems

The FSB4 Fluid Head has a payload of 8.8 lbs. ideal for lightweight HDV cameras and accessories, and the FSB8 holds cameras to 19.8 lbs.

- 75mm bowl • Touch & Go quick release

Kits include:

- **#SAFSB4ML2S** FSB4 Fluid Head, ENG75-2D Tripod, Mid-Level Spreader and Soft Case (0373)
- **#SAFSB4MLCFS** FSB4 Fluid Head, Speed Lock 75CF 2-Stage Tripod, Mid-Level Spreader and Padded Bag (0375)
- **#SAFSB8ML2S** FSB-8T Fluid Head, ENG75-2D Tripod, Mid-Level Spreader and Sof Case (0743)
- **#SAFSB8ML2S** FSB8 Fluid Head, ENG75-2D Tripod, Mid-Level Spreader and Soft Case (0773)

Mfr Model #	FSB4 Systems		FSB8 Systems	
	0373	0375	0743	0773
Payload Range	0-8.8 lbs	0-8.8 lbs	2-20 lbs	2-20 lbs
Extends	30.3-63"	30.3-63"	30.3-63"	30.3-63"
Folds to	33.1"	33.1"	33.1"	33.1"
Stages/Material	Aluminum	Carbon Fiber.	Aluminum	Aluminum
Weight	11 lbs	10.8 lbs	11.9 lbs	11.9 lbs
Counter Balance	5 Steps	5 Step	10 Steps	10 Steps
Horiz/Vert Drag	5+5	5+5	5+5	5+5
Price	899.95	1159.99	1879.95	1899.95



FSB-CELL SERIES

FSB Fluid Head Camcorder Power Solution

sachtler

The FSB F-Cell power system is designed to mount onto the Sachtler FSB-2/FSB-6 series heads, giving the camera operator a long-lasting battery while maintaining steady, even pan/tilt action. The battery is adaptable to various camcorders with an optional camera-specific adapter.



FSB-Cell battery 7.2 V/ 10.5 Ah battery #SAFSBC.....	209.00
Battery charger—for FSB-Cell (90-250 VAC, 50-60 Hz) #SACFSBB.....	169.99
Complete power kit with Sony PD/VX camcorder adapter #SAFSBPSSP.....	449.95
Complete power kit w/Sony HVR-Z1U/V1U/FX1/FX7 camcorder adapter #SAFSBPSSH.....	449.95
Complete power kit with Canon XL/XH/GL series camcorder adapter #SAFSBPSC.....	Call
Complete kit w/Panasonic AG-DVC/DVX/HVX series camcorder adapter #SAFSBPSP.....	Call

VISION AS SYSTEMS

Pro Tripod Systems

- Variable fluid head with interchangeable springs • Illuminated bubble level
- Sliding plate • 1-year warranty

Kit includes:

Vision AS fluid head, Pozi-Loc tripod, spreader & soft case; free counterbalance spring

Mfr Model #	V5AS-AP1M	V5AS-AP2F	V8AS-CP1M	V8AS-CP2F	V10AS-CP2F
SKU#	VIV5ASAP1M	VIV5ASAP2F	VIV8ASCP1M	VIV8ASCP2F	VIV10ASCP2F
Payload	9.9 lbs	9.9 lbs	12.1-27.6 lbs	12.1-27.6 lbs	14.3-32 lbs
Extends	63.5"	67.5"	63.1"	67.9"	67.9"
Folds to	40.3"	34"	40.4"	34.1"	34.1"
Stages/Mat	1/Alum.	2/Alum.	1/Carbon Fiber	2/Carbon Fiber	2/Carbon Fiber
Weight	17.7 lbs	18.2 lbs	17 lbs	17.4 lbs	17.7 lbs
Base Fitting	75mm	75mm	100mm	100mm	100mm
Counter Bal.			Variable Option		
Drag			Infinite	Variable	
Price	3014.50	2977.95	4464.50	4404.95	5341.69



SOLO ALUMINUM / CARBON FIBER SERIES
Tripod Systems

MILLER

- Ring lock leg extensions • Spike or wind-down rubber feet • 75mm base
- 3-Position leg angle locking • Selectable counterbalance • 3 yr warranty

Solo Aluminum Kit includes:

DS-Series head, Solo alloy tripod and soft case

System	1637	1640	1643
SKU #	MIDS5SDVAT	MIDS10SDVAT	MIDS20SDVAT
Max Load	5 lb.	5-10 lb.	10-20 lb.
Extends to	14.5-69"	14.5-69"	14.5-69"
Folds to	32.9"	32.9"	32.9"
Stages/Material	2/Alum.	2/Alum.	2/Alum.
Weight	12 lb.	14.51 lb.	14.51 lb.
Horz/Vert Drag	Variable	Variable	Variable
Price	Call	1079.99	1339.99



Solo Carbon Fiber Systems Kit Includes:

Mfr Model #	1511	1514	1793	1709
SKU #	#MIDS10SDV2	#MIDS20SDV2	#MIA25SE3SCFS	#MIA40SE3SCFS
Payload Range	5-10 lbs	10-20 lbs	12-30 lbs	15-40 lbs
Min/Max Height	14.5/69"	14.5/69"	14.5/76"	14.5/76"
Folds to	33"	33"	37"	37"
Stages	2	2	3	3
Weight	12 lbs	12 lbs	14 lbs	14 lbs
Bowl	75mm	75mm	100mm	100mm
Counter Balance	Selectable	Selectable	4 Position	4 Position
Pan/Tilt Drag	Variable Dial	Variable Dial	5 Step w/0	7 Step w/0
Includes	DS-10 Fluid Head, Solo DV Carbon Tripod, Soft Case, Carry Strap	DS-20 Fluid Head, Solo DV Carbon Tripod, Soft Case, Carry Strap	Arrow 25 Fluid Head, Solo ENG Carbon Fiber Tripod, Soft Case, Carry Strap	Arrow 40 Fluid Head, Solo ENG Carbon Fiber Tripod, Soft Case, Carry Strap
Price	1249.99	1479.99	4049.95	4819.95

ARROW SERIES

Pro Tripod Systems

The new Miller Arrow series offers a new range of precision-engineered fluid heads. They deliver true fluid pan and tilt action, rock-solid engineering, and a 3-year warranty.

- **#MIA25SSAS2SQ** Arrow 25 head, Sprinter II 1- Stage Alum. Tripod, Pan Handle, Mid-level Spreader, soft Case (1770)
- **#MIA252SCFS2S** Arrow 25 Head, Sprinter II 2-Stage Carbon Fiber Tripod, Handle, Mid-Level Spreader, Case (1778)
- **#MIA402SS2AS** Arrow 40 Head, Sprinter II 2-Stage Alum. Tripod, Telescoping Handle, Mid-level Spreader, Case (1686)
- **#MIA402SS2CFS** Arrow 40 Head, Sprinter II 2- Stage Carbon Fiber Tripod, Telescoping Handle, Mid-Level Sprdr, Case (1690)
- **#MIA55SS2ASQ** Arrow 55 Head, Sprinter II 1-Stage Alum. Tripod, Telescoping Pan Handle, Mid-level Sprdr, Soft Case. (1718)



MILLER

Mfr Model #	1770	1778	1686	1690	1718
Payload Range	11-30 lbs	11-30 lbs	15-35 lbs	15-35 lbs	22-55 lbs
Max Height	63"	66"	66"	66"	63"
Transport length	44"	38"	38"	38"	44"
Stages/Material	1/Alum.	2/Carbon	2/Alum.	2/Carbon	1/Alum.
Weight	16 lbs	16 lbs	16 lbs	18 lbs	18 lbs
Ball Fitting	100mm	100mm	100mm	100mm	100mm
Counter Balance	4 Step	4 Step	4 Step	4 Step	4 Step
Pan/Tilt Drag	5 Step w/0	5 Step w/0	7 Step w/0	7 Step w/0	7 Step w/0
Price	4584.95	5232.95	5486.95	5809.50	5877.95

FSB-4 / 6 / 8 SOOM

Soom Tripod System

Whether you're shooting in the studio or over a crowd in the field, the new SOOM tripod line combines legendary Sachtler reliability and balance in a great, versatile system that can meet all your shooting needs. A HiPod center column tube gives you level, rock-solid filming at over 8 feet.

System includes:

FSB-6 fluid head, SOOM tripod, SOOM TriSpread, SOOM tube, rubber feet, and SOOM bag (0480)

System	0380	0480	0760
Mfg. Item #	SAFSB4S	SAFSB6S	SAFSB8S
Max Load	8.8 lbs	13.2 lbs	20 lbs
Extends to	94.9"	27 to 55.5" / 94.9"	94.9"
Folds to	44.5"	32.5"	44.5"
Mount	75mm	75mm	75mm
Stages/Material	1/Alum	1/Alum	1/Alum
Weight	18 lbs	18.4 lbs	18.6 lbs
Carrying Case	SOOM bag	SOOM bag	SOOM bag
Price	2494.95	2985.00	3436.00



sachtler

SYSTEM 18S1 / SYSTEM 20 S1 SERIES

Pro Tripod 18S1 Systems

- System 18 S1 supports 4-40 lbs • 100mm base
- 16-step counter balance • 0-7 step horiz/vert drag

Kit Includes: • Vision 18 S1 speed balanced fluid head, tripod, spreader & case • Pro tripod 20 S1 systems • Support up to 55 lbs • 16-step dynamic counterbalancing system • Includes: video 20 S1 (speed balance) fluid head, carbon fiber tripod, mid-level or ground spreader and case

• Systems 2074 S1 & 2075 S1 incorporate "speed lock" tripod leg clamp

Mfr Model #	1861S1	1862S1	1863S1	1864S1	1865S1
SKU#	SAS18S12D	SAS18S12CF	SAS18S12MCF	SAS18S1SLCF	SAS18S1SLMC
Extends	24.4-67.7"	24.8-67.7"	26.44-66.1"	24.8-67.7"	24.8-67.7"
Folds to	35"	35"	35"	35"	35"
Stages/Material	2/Alum.	2/CF w/Spd.Lock	2/CF w/Spd.Lock	2/CF	2/CF
Spreader	Floor	Floor	Floor	Ground Level	Mid-Level
Case	Padded	Padded	Padded	Padded	Padded
Price	6599.95	7079.95	7299.95	7299.95	7799.95

Mfr Model #	2062S1	2072S1	2073S1	2074S1	2075S1
SKU#	SAS20S12CF	SAS20S1HDCF	SAS20S1HDMCF	SAS20S1SLHDC	SAS20S1SLHDM
Price	8649.95	8699.95	9449.95	8849.95	9574.95

sachtler



FOCUS PRO SERIES / LASER PRO SERIES

Focus Pro Tripod Systems

- Payload support 10 to 22 lbs • Continuous counter balance • 100mm base • Continuous horiz/vert drag
- Illuminated level • 5-year warranty

Kit includes:

F100 focus head, ultra-light tripod, spreader & soft case

Laser Pro Tripod Systems

Kit includes:

Z100 Laser head, ultra-light tripod, spreader & soft case

Mfr Model #	F101	F102	F104
SKU#	CAF101	CAF102	CAF104
Extends	33-61"	33-61"	33.5-63.5"
Folds to	40"	40"	40.25"
Stages/Material	1/Alum.	1/CF	1/Alum.
Spreader	Mid-Level	Mid-Level	Floor
Price	1273.95	1472.95	2049.95

Mfr Model #	Z101	Z102	Z103	Z104
SKU#	CAZ101	CAZ102	CAZ103	CAZ104
Extends	33-61"	33-61"	36-61"	33.5-63.5"
Folds to	40"	40"	41"	40.25"
Stages/Material	1/Alum.	1/CF	1/Alum.	1/Alum.
Spreader	Mid-Level	Mid-Level	Mid-Level	Floor
Price	2699.95	2979.50	2999.95	3159.95



CARTONI

CINE 7+7 HD SYSTEM SERIES

Pro Tripod Systems

- 100mm base fitting • 16 steps counterbalance

Kit Includes:

- **#SAS7E2CF** Cine 7+7 HD Fluid Head, Cine 7+7 HD Fluid Head, with Floor Spreader, and Carrying Bag (1962)
- **#SAS7HD** Cine 7+7 HD Fluid Head, DA 100 HD 2-Stage Tripod, Mid-Level Spreader, Rubber Feet (1970)
- **#SAS7HDCF** Cine 7+7 HD Fluid Head, Cine 7+7 HD Fluid Head, On-Ground Spreader, Front Pan Bar and Padded Case (1972)
- **#SAS7SHDMCF** Cine 7+7 HD Fluid Head, ENG 2CF Speed lock CF 2-Stage Tripod, Mid Level Spreader, Front Pan Bar, Rubber Feet and Padded Case (1975)

Mfr Model #	1962	1970	1972	1975
SKU#	SAS7E2CF	SAS7HD	SAS7HDCF	SAS7SHDMCF
Payload Range	4-48 lbs	4-48 lbs	4-48 lbs	4-48 lbs
Extends	24.8-67.7"	32.3-62.6"	28.3-70.1"	28.3-70.1"
Folds to	35"	35"	37"	37"
Stages/Material	2/Carbon Fiber	2/Aluminum	2/Carbon Fiber	2/Carbon Fiber
Weight	17.7 lbs	22.7 lbs	22.7 lbs	22.7 lbs
Horiz/Vert Drag	7+7	7+7	7+7	7+7
Price	8699.95	8216.50	9598.95	9894.95

sachtler



Ultimate 2575B Fluid Head

Professional Fluid Head 150mm Base

engineered for supporting 35mm film cameras. Capable of supporting camera payloads up to 133 lbs and offers handle connections on all four corners.

- Sinusoidal Counterbalance System
- True Fluid Dampening
- Dual Adjustable Pan Arms
- Dependable Caliper Disk Brakes

- C1234-000** ULTIMATE 2575D Professional Fluid Head Package 150mm (Black) #C2575DPKQG..... **Call**
- #OCCHDT150 (C1221-0003)** Cine HD single-stage alum. (150MM)..... **1999.95**
- #OCCHDBT150 (C1221-0004)** Cine HD baby single-stage alum. Tripod(150MM)..... **1999.95**
- #OCSCFCHD (C1222-0015)** Floor spreader for Cine HD tripods..... **584.95**



OCONNOR

VariZoom

VZ-ZG Zero Gravity Head

Award-winning design allows exact center-of-gravity balance, so user can adjust pan/tilt to any position without needing to tighten the drag control.

- 25 lb load capacity, complete 360-degree pan or tilt function
- Allows user to tilt higher and lower than most tripod heads
- Designed to work with tripods and camera cranes



#VAVZZG Zero Gravity Tripod Head **524.99**

VZ-MC100 / VZ-MC100D Pan and Tilt Head

Remote-controlled pan and tilt system supports camcorders up to 20 lbs.

- Pan/tilt head • Control grip/box
- Hard case • Power supply w/20' cord

#VAVZMC100 **2849.99**
 #VAVZMC100D Kit adds two VZ-MC100 pan/tilt heads **4359.95**
 #VAVZEXTMC50
 Extension cable 50' **109.95**
 #VAVZEXTMC100 Extension cable 100' **122.95**
 #VAVZCS1 Desktop support station **267.95**



GLIDECAM

VISTA HEAD SERIES Pan and Tilt Head

The Glidecam Vista head offers full 360° pan and tilt action, supporting cameras weighing up to 20 lbs—or 30 lbs on the Vista II.

- Operates via a joystick controller and a 15' extension cable
- Includes a 12-volt AC transformer and power converter
- Operates together with the Glidecam Camcrane 200



#GLVH Vista head that supports up to 20 lbs **2194.95**
 #GLVHD2 Vista II head that supports up to 30 lbs **2574.95**

VC Vista Camera Crane System



This crane and head system offers quick assembly and precise, 360° maneuverability with zero deflection.

- Designed to raise the height of a camera weighing up to 40 lbs to over 30 feet.
- #GLVC 26' Crane with Vista Head III—up to 40 lbs ... **17774.95**

Libec

LS-100PD (S) Studio Pedestal Pneumatic Studio Pedestal

The system consists of the P110 pedestal, H100 fluid head, and two PH7 fixed-length pan arms.

- Dual mechanism/pneumatic column (air pressured)
- Continuous pan/tilt drag and counter balance
- Safety valve over-pressurizing protection • 100mm claw ball



#LILS100PDS Supports 11–55 lbs **8447.50**

LS-70PD Studio Pedestal System

The Libec LS70PD studio pedestal system consists of the P110 studio pedestal, the H70 fluid head, and two PH-7 pan arms.

- Two-stage pneumatic system
- Variable air pressurized fully adjustable design
- Continuously adjustable pan and tilt • Max height 68"
- Continuous adjustable counterbalance head • 100mm base



#LILS70PDB Supports up to 17–33 lbs **5548.95**
 #LILS70PDS Supports up to 13–33 lbs **6114.95**

sachtler

2580 SYSTEM 25 PLUS Combi Pedestal System

This pro-level pedestal was created for today's ultra-sharp HDTV and widescreen cameras. 18-stage counterbalances, 7-step drag levels and 9-stage fine-tuning assure flawless, vibration-free footage.

- Pneumatic anchor column for quick height adjustment • Overload-protection mechanism realigns wheels quickly
- Superb movement across both horizontal and vertical planes • Crab/steer movements achieved with provided detachable steering ring



#SAS25C140 **16946.95**

Vinten

VISION V3951-0001 PED Plus Studio Pedestal

Ideal for all small production studios, this fully portable pneumatic camera mount is designed to support up to 66 lbs. It consists of a central telescopic column and a skid assembly with castoring wheels. To facilitate transport, the telescopic column and skid may be separated and the skid folded.

- Max. ht: 63", min. ht: 29.5"
- 100mm leveling bowl adapter
- Doorway tracking width 27" • Weight: 33 lb



#VIV39510001 Supports up to 66 lb **4369.50**

CAMBO

99134010 V-5 Telescopic DV Boom Arm

Telescoping DV camera crane designed to offer professional crane movement for small-sized cameras and equipment up to 6.6 lbs. This device utilizes male/female connection with precision security.



- Adjusted above the tripod height from 135cm to 275cm for specific applications.
- Interlocking easy assembly design

#CAV5TDB **1849.95**

MILLER

PEDESTAL 30 / PEDESTAL 60 Studio Pedestals

With a maximum payload capacity of 30.8 lbs, this highly portable stand is perfect for lightweight cameras. Height range of 31.7"–41.7".

- Flat base for universal head attachment
- Gas-assist pump column can be locked and dampened
- Adjustable column elevation height range of 10"
- Smooth lockable 4" caster wheel



Pedestal 30 supports up to 30 lbs **#MI730 1169.95**
Pedestal 60 supports up to 60 lbs **#MI732 1236.50**

Peter lisand machine corporation

STUDIO PEDESTAL Compact Studio Pedestal

The unit combines quality, strength, rigidity, and light weight to create an economical alternative to traditionally heavy and expensive TV studio pedestals.

- Center sealed, air-charged cartridge column • Payloads up to 50 lbs
- 100mm ball standard, "hi-hat" top
- Transport size 34" long x 12" diameter



#PEPLSP1 **1999.95**

CARTONE

P20 / PL20K / P50 / P900 Pneumatic Studio Pedestal

Perfect solution for lightweight studio or mobile needs. The pneumatic column allows for quick and easy height adjustment.

- Locking wheels • 100mm bowl
- Cable guards • High payload capacities
- Moderate doorway width



#CAP20 Supports up to 50 lbs **6369.95**
 #CAP20LK Kit includes the Z100 Laser fluid head & P20 pedestal—supports up to 55 lbs **7899.95**
 #CAP50 Supports up to 121 lbs **10703.50**
 #CAP900 Supports up to 198 lb **23282.95**

GLIDECAM

CAMCRANE 200 Camera Crane

This tripod mounted, boom-arm, camera crane system is designed to smoothly boom your camera with precision and fluidity—up, down and 360 degrees. It has 4 boom length combinations: 3.25', 4.8', 6.5' and 8.1', with 3 fulcrum (balance) settings.

- Payload capacity is 25 lbs @ 8', 30 lbs @ 6.5' • Variable vertical boom from floor to 10' or 8'
- Aluminum with black finish
- 3/8" standard tripod mount
- Folds to 3.3'



#GLCC200 **539.95**

CARTONE

M100

Portable Crane Jib Arm

This portable mini jib arm provides precisely balanced booming, with a load capacity of 33 lbs, from absolute ground level to 78 inches in height. Pans 360°, mounts to a 100mm bowl tripod.

- Payload capacity 33 lb
- Aluminum with black finish
- 39" to 78" (max height depends on tripod)
- 1" steel weight barbells included



#CAM100 **1999.95**

MILLER

PROJIB ARM Compact and Portable

Miller's jib arm weighs only 25 lbs but offers a payload capacity of 50 lbs—half the weight of many comparable jibs.

- Camera height range extends up to 78" (depending on tripod)
- Folds down to 48" and mounts to a 100mm bowl tripod
- Extends camera height range to 2 meters (6 ft), allowing a single operator to achieve impressive crane perspectives



#MI711 **2549.95**

VariZoom

VZ-CINETRAC

Heavy-Duty Track Dolly Platform



The dolly offers variable-length platform legs and tight-space maneuverability with cranes, jibs, and cams with teleprompters.

- Unique design allows large camera setups to maneuver in tight spaces
- Adjustable legs allow use with a variety of tripods

#VAZCINETRAC Heavy duty dolly **699.99**
 #VAZCTS Complete dolly kit **1455.07**
 #VAZTRACK Rubber track **459.95**

Libec

JB-30 Jib Arm and Tripod Kit

- Load capacity 44 lbs • Ground level to 72" in height • Precise balanced booming
- Reversible bowl for extremely low camera angles
- 75/100mm bowl base attachment
- Folds down to 46"



Kit Includes: Jib Arm, 75mm Adapter, Adjusting Weight, Under Mount, Padded Case, T101 Tripod, DL-8 Dolly

#LJJB30UHK JB-30 Jib Arm with T101 Tripod and DL-8 Dolly Kit **Call**
JB-30U Jib Arm with Undermount Adapter and Case only #LJJB30 **1999.59**



JONYJIB 9' / 12' / 15' / 18'

Jib Arm w/LCD Monitor Mount

With telescoping boom sections that nest within themselves for compact storage, this sturdy pro jib is supported by any heavy-duty 100mm tripod mount.

- Optional add-on boom sections
- Includes rear control center, mounting hub



JONYJIB 9' (supports 35 lbs) #J0JJ9 **1394.95**
JONYJIB 12' jib (supports 35 lbs) #J0JJ12 **1788.95**
JONYJIB 15' jib (supports 30 lbs) #J0JJ15 **2324.95**
JONYJIB 18' jib (supports 20 lbs) #J0JJ18 **2794.95**

INDIE-DOLLY SYSTEMS®

IND-S.KIT / IND-C.KIT & DOLLY
Dolly and Track Systems

Lightweight, with easy and secure setup, these dolly and track systems provide dolly shots with smooth and seamless movement.



IND-S.KIT Straight Track Kit #INSTK **544.95**
IND-C.KIT Curved Track Kit #INCKT **639.95**
IND.CTD Universal Dolly f/Indie-Dolly Tracks #INCTD **1194.95**
IND.PF Accessory Platform—for dolly system #INDPF **Call**
IND.PF2 Second Accessory Platform #INPF2 **324.95**
INDDK INDIE-DOLLY DELUX KIT #INDDK **4899.95**

Libec

TR-320 / CR-90 Dolly Track-Rail System

This portable, modular system works with your existing tripod for excellent cine-style dolly shots. Lightweight aluminum track assemblies easily.



TR-320 kit includes: 8 pcs of 32" straight track, universal dolly, case
CR-90 kit includes: 4 pcs of 45° curved rail for 90° turns, case

TR-320 Straight track kit #LITR320 **2079.95**
CR-90 Curved track #LICR90 **749.95**



377702 Adjustable Bazooka

Used for dollies and studio catwalks, this adjustable stand weighs 11 lbs and extends from 24" to 39". It holds a maximum load of 100 lbs.



515003 Elemac mounting plate required to mount bazooka #MAEMP **149.95**
845120 Elemac to 100mm bowl mount #MACBCA100 **349.95**
515021 Elemac to Elemac extension arm #MAEEAB **307.50**
515024 Offset Elemac to Mitchell adapter #MAEMA **434.95**
377702 Bazooka itself #MABAZ **1076.50**

ROUND-D-ROUND

Doorway Dolly

This versatile mobile camera platform is an excellent choice for stage or location.

- All-wheel steering, navigate a tight 90° corner
- The camera operator is able to mount into six different fixed locations
- Steering is possible from both ends of the dolly
- Platform is carpeted for a non-slip low maintenance surface
- 51" x 28.25" (LxW) platform • Load capacity 1100 lbs
- An optional second seat and offset arm can also be installed



#MARDRDDW **2660.59**

BRIEFCASE DOLLY Platform Dolly

All dolly components are packed within a heavy-duty case that opens into the 6" x 19.5" x 29" dolly platform itself. Self-contained with both surface and track wheels for regular track, PVC, metal or "focus track."



- Supports 500 lbs on either straight or curve track
- Airline transportable

#MADBC **2764.95**

DOORWAY DOLLY Platform Dolly

The platform is fitted with a recessed camera tie-down and is carpeted for a non-slip, low maintenance surface.

- Carpeted platform 27.5" x 41.5", overall 51" long
- Load capacity of 800 lbs
- Wheel base of 28.25 w/out extended axle
- Quick-change pneumatic wheels
- Dolly can be inverted
- Rear wheels extend outward for operating stability



#MADDW **1769.99**
 #MADDWT with Turret **5179.95**

EGRIPZ

Handheld Camera Support

Adapt this flexible, handheld support into virtually any position or configuration, enhancing and facilitating smooth camera operation.

- Features 1/4-20 mounting base
- Attaches easily to a monopod or other support base for additional stability, and can serve as a comfortable camera shoulder support.

#ANEGRIPZ **69.99**



STASIS FLEX

Shoulder Mount Camera Stabilizer

The Stasis Flex system utilizes a flexible arm and adjustable chest pad for any body style. Position the camera into virtually any shooting position—forward/back, in/out, or up/down.

- #ANSF STASIS FLEX flexible shoulder mount bracket **265.59**
- #ANSFS STASIS FLEX w/FGM-S Gold mount & cable for Sony 7.2VDC camcorders **418.50**
- #ANSFP STASIS FLEX w/FGM-P Gold mount & cable for Panasonic 7.2VDC camcorders... **413.50**
- #ANSFEX STASIS FLEX w/FGM-EX1 Gold mount & cable for Sony PMW-EX1 camcorder... **418.50**



HDV-Pro Series

Shoulder Mount Support

Intended for event videographers using lightweight HDV/DV camcorders, this shoulder bracket provides wide, comfortable support positions that allow prolonged shooting.

- Adjustable flexible shoulder pad
- Adjustable quick-release

- HDV-Pro Shoulder bracket #SWHDVPRO..... **269.95**
- HDV-Pro/V HDV/DV Camera Shoulder Support with V Plate #SWHDVPROV **349.95**
- HDV-Pro/A Shoulder Support with Battery Mount #SWHDVPROA..... **349.95**



S-800

Shoulder Mount Support

This fully adjustable shoulder rest fits all consumer/prosumer camcorders to keep your shots steady while reducing fatigue.

- Smooth, steady video
- Adjust length 6.5", horizontal adjustment 90°
- 2 accessory bars for monitor, mic and light
- Handle can be located in 2 positions
- Foam cushion arch contoured to fit shoulder slope
- Folds to 12 inches for storage and travel
- Weighs less than 20 oz

#VIS800SP Shoulder bracket (Mfr #125) **\$89.95**



388166 / 200016 / 388194

Shoulder Mount Supports

Designed to support small and medium-sized camcorders with viewfinders or flip-out screens, these padded shoulder rests include an adjustable camera platform and a choice of one or two arms with padded handgrips.

- 388166** 1 arm for smaller camcorders #BISHSS..... **349.95**
- 200016** 2 arms for Canon XL-1/2/H1, Sony PD150/170 #BIDHSS..... **494.99**
- 388194** 2 arms for Panasonic AG-DVX100B, Canon XL/GL #BIDHSSL..... **474.95**



MIGHTY-WONDERCAM

Classic Shoulder Pod

Designed for small camcorders, this rugged, lightweight shoulder pod has five adjustable axes to comfortably fit most camcorders and videographers.

- Fully adjustable cushioned hand grip w/stainless steel foot
- Seven available mounts for attaching accessories
- Self contained—no dangling cables
- Accepts Sony's GP-TRX grip

#MICQ **214.99**
#MICABP Classic Shoulder Pod with AB Pad Support **249.95**



FIG RIG

Handheld Stabilizer System

The Fig Rig's unique, highly effective design helps absorb handheld shocks and extraneous movement.

- Padded handgrip for a comfortable, secure grip
- 4 supplied cable clips keep cables out of your shot
- Includes a 501PL sliding quick-release plate

#MA595B Fig Rig Camera Stabilizer..... **281.99**



BCS05

Shoulder Mount Support System

This custom-designed shoulder bracket with adjustable waist belt gives the camera operator extra support and eliminates fatigue. Splits the camera's weight between the videographer's shoulder and hip to provide more stability.

- Lockable pivoting arm w/variable up/down adjustments
- Bendable shoulder pad to custom fit any shoulder

#PEBCS05 **349.95**



STABLE-CAM

Shoulder Mount Support System

The Frezzi Stable-Cam balances the camera on 3 body points, making the camera a natural body extension, while eliminating wrist and hand fatigue. Includes V-Lock battery bracket.

- DV power and lighting platform
- 4 sturdy handgrips
- Extra mounting shoe
- Fully adjustable Hip-Grip
- Lightweight
- Allows removing hands from camera

#FRSCVL **684.50**



ORBITOR

Shoulder Mount Support System

With effortless control, the PAG Orbitor allows a wide range of shooting techniques while your camera feels weightless.

- Balanced and stable shooting platform
- Reduces fatigue on long shoots
- 3-axis control lets you pan, tilt and roll, smoothly
- Fully adjustable for any operator

#PAOCCS **694.95**



DV MEDIA RIG

Pro Support System

The DV Media Rig Pro is a top-of-the-line, articulating weight balance system for camcorders weighing up to 7 lbs. Its precision machining, spring-loaded abdominal suspension pod and swiveling shoulder arch add comfort and professionalism to any shoot.

- Includes full tilt, side-to-side, and front-to-back axis capabilities
- Rotating accessory mount for lights, monitors, mics and more

#VAZDVMR..... **569.99**



VZ-LSP / VZ-1SHOOTER

Shoulder Mount Support Systems

Crafted with precision from machined aluminum, this tough, lightweight shoulder brace has 10 adjustable fittings. For camcorders weighing up to 8 pounds, the VZ-LSP lets you shoot fatigue-free all day. The VZ-1Shooter is for smaller cameras, and is a great entry-level choice.

VZ-LSP w/abdominal brace #VAZLSP..... **404.95**
VZ-1Shooter #VAZ1SHOOTER **114.99**



MERLIN

Handheld Stabilizer Systems

The unique design of the Merlin stabilization system is manufactured to provide you with an ultra-lightweight solution that not only increases stability, but can go simply anywhere. Ultra-light and ultra-compact, the Steadicam Merlin allows you to keep up with the action more easily than ever.

The Steadicam custom-fitted Merlin travel case allows you to securely cradle your camcorder while it is affixed to and balanced on the Merlin. Upright and easily accessible, the case lets you get ready quickly before your next shoot. Offers generous space to store the Merlin Arm and Vest plus additional gear.

With the Merlin Arm and Vest you have the choice of using the Merlin lightweight camera stabilizing system for fluid hand-held shooting in the same manner as the larger Steadicam rigs used in Hollywood film productions.

- "Folding-Caliper" hinge allows for instant fold-up—perfect for shoulder-mounted shooting
- Quick-release mount

Merlin with "New Metal Gimbal" balances cameras up to 0.5 to 5 lbs #STM.....**749.95**
Arm and Vest with Merlin, balances cams up to 7.5 lbs #STMAVK **2494.95**

STEDICAM



2000 PRO / 4000 PRO
Handheld Stabilizer Systems

GLIDECAM

The Glidecam 2000/4000 Pro camera stabilizers are lightweight, handheld, camcorder-stabilizing systems which facilitate motion shoots that need to be incredibly smooth and graceful, even when running up and down stairs or traveling over rugged terrain.

- #GLGL2000 Supports up to 6 lbs..... **284.99**
- #GLGL4000 Supports 4 to 10 lbs..... **349.95**
- #GLGCFB Forearm Brace..... **149.95**



- #GLGL2000K2 Kit with GL-2000 PRO, Forearm Brace, L4-Pro Monitor and Battery..... **889.95**
- #GLGL4000K2 Kit with GL-4000 PRO, Forearm Brace, L4-Pro Monitor and Battery..... **959.95**
- #GLGL2000K3 Kit with GL-2000 PRO, Body Pod, L4-Pro Monitor and Battery..... **899.95**
- #GLGL4000K3 Kit with GL-4000 PRO, Forearm Brace, L4-Pro Monitor and Battery..... **994.95**

HD1000 / 2000 / 4000
Camera Stabilization System



The amazingly advanced Glidecam HD-Series represents the top of the line in handheld camera stabilization. These lightweight, state-of-the-art camera stabilizers will transform your shaky camera footage into hypnotically smooth, professional-looking images.

- Integrated quick-release camera plate
- Adjustable convergence, precision, 3-axis gimbal
- Adjustable dynamic balance and inertial control base platform
- Foam padded handle grip

- HD1000** for cameras up to 3 lbs #GLHD1000 **329.95**
- HD2000** for cameras from 2–6 lbs #GLHD2000 **449.95**
- HD4000** for cameras from 4–10 lbs #GLHD4000 **549.99**

SMOOTH SHOOTER
Camera Stabilization System

GLIDECAM

The Smooth Shooter system is designed to work with Glidecam's GL-2000 and 4000 Pro handheld camera stabilizers. Glide effortlessly over rough terrain to achieve smooth, track-like footage.

Smooth Shooter includes:

- Smooth Shooter support vest
- Dyna-Elastic arm
- Stainless steel arm post
- 6x steel weight plates
- Docking bracket

#GLSS Smooth Shooter vest and arm system **1394.95**

Smooth Shooter kits:

- #GLSSK Kit includes Smooth Shooter system and GL-4000 Pro stabilizer **1699.95**
- #GLSSK1 Kit includes Smooth Shooter, GL-2000 Pro, L4-Pro 4" TFT LCD, BP-L4P battery pack **2094.95**
- #GLSSK2 Kit includes Smooth Shooter, GL-4000 Pro, L4-Pro 4" TFT LCD, BP-L4P battery pack **2174.95**



ULTRALITE

Handheld Stabilizer System

VariZoom

This UltraLite handheld stabilizing system achieves smooth, flowing images while you walk or run over rough terrain or up/down stairs.

- Supports 2–7 lb camcorders
- Equipped w/quick release plate
- Pedestal base plate
- Locking gimbal
- Compact and lightweight

#VAVZUL **294.95**



FLOWPOD

Handheld Stabilizer System

VariZoom

The FlowPod is ideal for camcorders weighing up to 8 lbs—giving you stability and smooth footage while walking, running or going up and down stairs.

- Adjustable vest for comfort and performance

- #VAVZFP with Case **379.95**
- #VAVZFPK with Low Flow Kit & Case **469.95**
- #VAVZDVSPORTE FlowCam DV Sportster..... **759.99**
- #VAVZDVSPMS DV Sportster Master System **1154.95**



DV SPORTSTER / NAVIGATOR*
Camera Stabilization System

VariZoom

Upgrade your handheld stabilizer to a professional vest-supported system with these universal articulated arm and support vests.

**Navigator can be upgraded w/a GT sled, into a full professional system.*

- #VAVZDVSPORTE DV Sportster with Arm, Vest & Case... **759.99**
- #VAVZN Navigator w/Arm and Vest System only **1139.95**
- #VAVZNK1 Navigator w/Glidecam 2000 Pro **1394.95**
- #VAVZNK2 Navigator w/Glidecam 4000 Pro **1414.95**
- #VAVZNK3 Navigator w/FlowPod, Low Flow Kit, FlowPod Case **1514.90**



SP1 STEDDIEPOD
Camera Stabilizer

BARBERTECH
VIDEO PRODUCTS

Handheld camcorder stabilization system. This system offers many variations in one system. It can be a monopod, a tripod, a camera stand, a body camera mount or a low mode system. Handheld stabilizer for classic moving shots. This device also can be a monopod for excellent quick stability in live situations. It can be extended and pressed against the body and used to shoot and can be used as a low-mode device sometimes called a dog or kitty cam.

- Created by Eddie Barber
- SP1 SteddiePod #BASP 389.95**



GLIDECAM X-10

Camera Stabilization System

This highly advanced professional stabilization system is designed specifically to be used with Glidecam's GL-2000 and 4000 Pro handheld stabilizers. The system works by isolating your body's motion from the camera, leaving your camera balanced and in a relatively motionless state. The support arm can be boomed up and down, as well as pivoted in and out and side-to-side as you to create smooth camera footage. Walk, run, go up and down stairs, shoot from moving vehicles and travel over uneven terrain without any camera instability or shake. The support vest is lightweight, comfortable, and can be adjusted to fit a wide range of operators, while the support arm can be set up and configured so that either a left-handed or right-handed operator can use the system.



X-10 System includes:

X-10 Support Arm, Support Vest, Docking Bracket, Stainless Steel Arm Post, Aluminum Arm Post, (6) Steel Weight Plates.

X-10 Stabilization System

#GLX10	2099.95
X10 System with GL-4000 Pro Handheld Stabilizer	
#GLX10K1	2299.95
X10 System with GL-4000 Pro Handheld Stabilizer	
#GLX10K2.....	2374.95



Glidecam HD4000K4 Kit 4 Stabilizer System

- For Small Cameras • Bonus Balance and Docking Bracket • X-10 Dual Arm Support System
 - L4-PRO LCD Monitor • Battery Pack • 4-10 lbs Capacity
- B&H Kit #GLHD4000K4..... **2994.95**

X-45

Camera Stabilization System

The Glidecam X-45 is a professional, body-mounted, camera stabilization system designed for film and video cameras weighing up to 45 pounds. The Glidecam X-45 System incorporates advanced engineering and precision machining. The Glidecam X-45 is the most versatile and affordable system available today for cameras up to 45 pounds. The complete system is comprised of a Vest, Support Arm and Sled with LCD.



#GLX45 Camera Stabilization System **Available Soon**

PILOT AB/VL/AA

Camera Stabilization Systems

The Steadicam Pilot is a lightweight stabilizer system designed for the video professional to capture smooth, fluid movements with cameras weighing from 2 to 10 pounds. Its two-section, articulated design includes a frictionless, silky-smooth Iso-Elastic arm, ultra low profile vest, lightweight sled with Carbon-Lite expandable post, color 3.5" LCD monitor (upgradeable to 5.8"), and low-mass gimbal. 12v battery pack options are: "AA" battery pack, V-Lock or Anton Bauer.



Pilot with Sony V-Mount Battery Mount #STPVL.....	3749.95
Pilot with Anton Bauer Battery Mount #STPAB	3699.99
Pilot with AA Battery Mount #STPAA	3599.99
Pilot with two IDX E-7S lithium-ion V-mount batteries and charger #STPIDX	4649.99

AVIATOR / BLACK HAWK

Camera Stabilization Systems

Designed for cameras weighing 5–15 lbs, the Aviator's dual-arm stabilization system offers fluid, lightweight camera movement with convenient no-tools adjustment. The top-of-the-line Black Hawk provides high-end performance for HD, broadcast and film cameras weighing 10–25 lbs.

Aviator kit includes:

- Li-Ion battery system • Custom rolling case • Training DVD

Black Hawk kit includes:

- Dual Anton Bauer mounts • NTSC/PAL toggle
- VZRockC zoom controller • Custom rolling case

Aviator (for camera rigs between 5–15 lbs) #VAVA	4053.50
Aviator with Anton Bauer mount #VAZAVIATORA	4053.50
Aviator with V-Lock mount #VAVBHAB ..	6374.95
Black Hawk with Anton Bauer mount #VAVBHAB	6374.95
Black Hawk with V-Lock mount #VAVBHVL.....	6374.95



Includes Free VariZoom VZRock Variable-Rocker for LANC Camcorders

X-22 Camera Stabilization System

Incorporating advanced engineering and precision machining, the Glidecam X-22 is a professional body-mounted stabilization system designed for film and video cameras weighing up to 22 pounds. The complete system is comprised of a dual-articulating support arm, a sled, and a lightweight support vest that can be adjusted to fit a wide range of operators. The patented and precision Dyna-Elastic support arm allows you to boom up and down or side-to-side—smoothly and with virtually no noise.



- Quick-release, high-impact buckles for quick vest removal
- Arm-to-vest connector allows attachment and removal without affecting trim settings • Field adjustable spring tension
- 2-spring or 4-spring modes • Light-Force technology for optimal buoyancy • "No-tools" precision gimbal

#GLX22VL V-Lock Mount	6999.95
#GLX22AB Anton Bauer Mount.....	6999.95

ZEPHYR

Camera Stabilizer System

A new innovative approach to camera stabilizer design, the Steadicam Zephyr has a host of "future proof" features that allow it to be a versatile and an ever evolving essential tool for camera stabilization needs. The new tools-free patented Iso-Elastic™ stabilizer arm supports 20 pounds of camera weight. The no-tools Arm /Vest interface allows for quick customization to the individual operator. "On the fly" weight adjustment frees the operator from dismounting the system to make changes. • 30 lb. arm lift capacity



- No-tools adjustable Iso-elastic™ arm
- HD ready with connector rich base and stage
- Dual axis vernier adjustable stage
- Unparalleled inertial control and dynamically adjustable base

Zephyr Complete system - Stars/Steadfast/SD Monitor #STZEPHYR..... **8995.00**

FLYER 24LE

Camera Stabilizer System

A remarkable combination of high-end features and affordable price, this lightweight stabilizer supports a 4–19 lb. camera load. It features Garrett Brown's patented Iso-Elastic stabilizer arm and gimbal for frictionless, silky-smooth movement, plus a newly designed camera mounting platform with a carbon fiber extendable post.



- Fully adjustable ergonomic vest for even load distribution
- Anton Bauer Gold Mount for 3-stud battery compatibility
- Tool-free locking mechanisms for quick, precise on-set adjustments
- 12 to 24VDC volt-switchable

Flyer 24LE Complete system #STF24LEAB.....	7349.95
Iso-Elastic Stabilizer Arm #STF24LEVL	7124.99
Red One Camera Compatible #STFLERED.....	14769.50

BARBERTECH EZ PROMPTER

Teleprompter System

The lightweight EZ Prompter weighs about 2 lbs, and is quick and easy to set up. Holds a sheet of 8 1/2" x 11" paper for up to 2 minutes of text. Your talent will look more confident, authoritative and professional. It fits onto 82mm filter thread lenses (85mm), and with optional lens adapters can be made to fit most other camera lenses smaller than 85mm.

EZ Prompter with hard case, shoulder strap #BAEP.. **559.95**
EZ Prompter Stealth
 (for lenses larger than 85mm) #BAEPS1 **569.95**



GO! PROMPTER

Portable On-Camera Teleprompter

This basic, fully positionable prompter consists of a 4" x 8" dry erase board with hardware enabling connection to a camcorder's hotshoe or lightshoe. No power or cables needed. Constructed of metal and durable plastics, the unit weighs only 10 oz and fits both pro and consumer camcorders.



#PRGP..... **49.95**
 #DRPOR1 Set of 4 dry erase marking pens **9.95**

ProPrompter HD

HD LCD or iPhone Teleprompters

This complete prompting system, in either LCD or iPhone version, is designed to work on any internal-focus camera lens with a diameter of 52mm to 100mm. A lightweight and durable system, it includes a hood and mirror designed to work with wide angle shots up to an aspect ratio of 16:9. The included SKB case accepts all of the system's components, which makes this prompter a great solution for use in mobile work or studio.



PP-400PM HD /Mobile Devices #PRPPHDPM **744.95PP-**
402V HD VGA LCD Package #PRPPHDVGA..... **1199.95**

ProPrompter HDi

For Apple iPad with Wing and Grip

Teleprompter made specifically for the Apple iPad. ProPrompter HDi attaches to pro and consumer cameras and uses a specially designed iPad bracket to securely hold your iPad whether you use a steadicam, jib or handheld. Made of aircraft grade aluminum, each ProPrompter HDi is made of the finest materials for rock solid performance and durability.

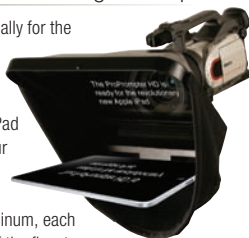

PP-HD-I HD Prompterfor iPad #PRPPHD1 **894.95**

ikan

PT1000 / PT1000W / PT2100
 Portable Teleprompter Kits

The PT2100 provides all the benefits of a thru the glass prompter in a lightweight, portable design. The anti-glare screen, with horizontal & vertical flip, displays 1024 x 768. The prompting software is easy to use, and allows for the adjustment of text, color, and size. PT2100 Supports NTSC/PAL and has VGA and video inputs. Includes: AC Adaptor, teleprompter assembly with glass, monitor kit, cables & software. For an ultra-portable solution, try the PT1000 or PT1000W. For a larger prompter, the PT3000 (mid-size studio) or PT4000 (full-size studio) are also available.



PT1000 4:3 aspect ratio Prompter Kit #IKPT1000..... **628.95**
PT1000W 16:9 Prompter Kit #IKPT1000W..... **679.99**
PT2100 Teleprompter Kit #IKPT2100 **799.99PT3000 Teleprompter Kit, 70/30**
Glass #IKPT3000.....1194.95
PT4000 Teleprompter Kit, 70/30 Glass
 Large Monitor #IKPT4000..... **2284.95**



ELP15-P / S

Professional Studio Teleprompters

light-weight economical teleprompter that is an ideal choice for transitioning to a full professional setup, or as an alternative to more expensive units. It can be mounted directly onto an Autoscript hood, retaining glass, or mounting assembly. An external 12v DC power supply is included with this unit. Moreover, support for NTSC, PAL, and SECAM are standard and default video inputs include Analog RGB, Component video, Composite video, S-Video, and VGA.



ELP15-P 15" portable #AUJEL15P..... **3456.95ELP15-S 15"**
studio #AUJEL15S.....3499.95

Rise & Fall Robotic Stand

Motorized Robotic Teleprompter Stand

Offering the ability to adjust its height automatically, this motorized robotic teleprompter stand is ideal for studio or location productions such as awards shows, conferences and presentations. Made of chrome, it features a special high-brightness backlight, built-in cue light and controls for color, brightness and contrast.

- Height range: 51.4"-82.9"
- Data control via BNC 75ohm cable
- Value-for-money Package
- Programmable Adjustments
- 15" LED Monitor Included
- Brightness - 1500 Nits • Darker 'Blacks'
- Instant Warm-up to Full Brightness
- Superior Light Distribution
- Reduced Power Consumption
- Illuminated Control Panel
- Reading Range - 15ft (5m)



#AUMRFSLED15T..... **8764.95**

LISTEC VIDEO

MZ-3000P Z-PRO SERIES
 Portable Presto System

The Z-PRO Presto teleprompter system is designed specifically for cameras with an ENG bayonet-mount lens. It includes a fold-down mirror, a soft hood assembly, and all other necessary hardware. Also included is the LCD-900 image reverser/VGA-composite converter for scan reversal and translation of your signal from VGA to composite video.



#LIMZP3000P portable system **1789.95**
 #LIMZP3000S studio system..... **2279.95**

T-2000 PromptBook

Notebook Prompter System Kit

Use the T-2000 PromptBook with supplied A-6000WIN prompting software, and your notebook computer (up to 8 lbs, max. 13 3/4" width) can serve as a flat-panel prompter. No other display is required. It can project a reverse mirror image for direct eye-line viewing. T-2000 weighs 11 lbs (minus counterbalance).



T-2000 PromptBook #LIT2000WIN..... **2699.95**

ENT-1717P SERIES

Entry Level On-Camera Prompter

This 17" prompter is designed for ENG, HD, and DV styled cameras. The ENT-1717P features 17" VGA display, fold-down mirror/soft hood assembly and easy-mount support hardware including camera riser and rear counterbalance weight. ENT-1717P-EZ includes 17" prompter with EZPrompt software for Windows. ENT-1717P-A6 includes 17" prompter with Listec A-6000WIN software for Windows.



ENT-1717P #LIENT1717P **1494.95**
ENT-1717P-EZ #LIENT1717PEZ..... **1884.95**
ENT-1717P-A6 #LIENT1717PA6 **2449.95**

17" Off-Camera Prompter

with EZPrompt Software

- 17" VGA flat panel display
- Tripod with spreader included
- LVC-526 EZPrompt software included
- 1280 x 1024 native resolution
- 160° viewing angle (H / V) for wider visibility
- 2000:1 contrast ratio
- 300 nits brightness ratio
- 50,000 hours backlight life
- Weighs only 20 lbs
- Internal power supply at 100-240 VAC



17" Off-Camera Prompter #LIEN17SAPEZ **1749.95**

Autocue QTV

PSP-08 / 12 / 17

Professional Series Prompters

Affordable solutions for smaller broadcasters and advanced institutional video departments. Designed with complete flexibility and configuration in mind, these prompters can be used with any camera/lens/fluid head combination. The ultra thin, high bright monitors have reverse scan, composite and VGA inputs, and are suitable for most studio lighting conditions.



OCU-PSP08SWAGP Pro. Series 08 #AUPSP08..... **2374.95**
OCU-PSP12MWAGP Pro. Series 12 #AUPSP12..... **3399.95**
OCU-PSP17MWAPP Pro. Series 17 #AUPSP17MWAPP **3949.95**

MSP-08 / 12 / 17 / 20

Master Series LCD Teleprompters

The Master Series – Autocue / QTV's premium teleprompting range – features cutting edge solutions for complex and demanding broadcast environments. Designed with complete flexibility and configuration in mind, these prompters can be used with any camera/lens/fluid head combination. The new LED backlight monitors provide unbeatable form factor, weight distribution, contrast ratios, and brightness for any lighting conditions.



OCU-MSP08SWAGP Master Series 08 #AUMSP08.... **3259.95**
OCU-MSP12MWAGP Master Series 12 #AUMSP12MWAGP..... **4799.95**
OCU-MSP12TOP Master Series 12 Top Mount #AUMSP12TM..... **4595.95**
OCU-MSP17MWAPP Master Series 17 #AUMSP17Y.. **6399.95**
OCU-MSP20LWAPP Master Series 20 #AUMSP20Y..... **Call**

QMaster / QBox

Master Series IP-Based Software Packages

Autocue/QTV's premium software is the world's only IP-based prompting system. Its unique benefits include redundancy, remote/distance prompting and standalone portable prompting. The QMaster software supports all Unicode languages, will interface to all NRCS via MOS or dedicated interface, and provides rundown and live edit capability.



SW-QMASTERSP QMaster/ QBox Software and ShuttlePro Control Package #AUQMASTER..... **3699.95**
SW-QBOX QBox only #AUQBPI..... **1744.95**

QPro Software

Professional Series Software Packages

Autocue/ QTV's professional level software-only packages come with runorder management, presenter profiles, word import, support for all Unicode languages, and multiple font type, sizes and colors.



SW-QPROSE QPro Software and ShuttleXpress Control #AUQPRO..... **1229.95**

MIRROR IMAGE
Teleprompters, Inc.

LC-150MP Prompter LCD

Complete prompting system that offers all the hardware and software you need to get started. The full system includes a 10" LCD that accepts high-quality VGA signals, a large trapezoidal hood & mirror for wide-angle HD cameras, a fold-down hood, an adjustable-height camera riser that will fit almost any camera, EZ Prompt software (for Windows XP), VGA cable, and mouse controller.



• Entry-Level Prompter • Wide-Angle Hood & Mirror for HD
LC-150MP Prompter LCD #MILC150MP..... **1999.95**

SF-160 / SF-190 /SF-220

Studio Series Prompter

Robust teleprompter designed for ENG and EFP cameras in a studio environment. The foundation of this set is a 15" color display from the Pro Series of LCD panels. The entire set includes a monitor, a large trapezoidal shaped hood, and a 21 x 16" beam splitter mirror. This model accepts SVGA, NTSC, or PAL video inputs.



SF-160 15" Pro Series LCD Studio #MISF160LCD... **3699.95**
SF-190MP 19" VGA Studio Prompter #MISF190MP **2999.95**
SF-220 19" Pro Series LCD Studio Prompter #MISF220LCD..... **4099.95**

CC-150MP / CC-150FS / CC-160

For Flush Cam-Corder Lens

The only prompter system designed to match up with flush mounted compact camcorder lens. Features an all metal rear hood and foam "light tight" gasket to replace the traditional fabric hood. HD-Wide Angle glass Beam Splitter mirror and adjustable camera mount included.



CC-150MP 15" VGA panel, EZPrompt software, 25' cable, mouse controller #MICC150MP..... **1999.95**
CC-150FS 15" VGA panel, EZPrompt software, 25' cable, mouse controller, tripod stand #MICC150FS..... **2149.95**
CC-160 15" Pro Series panel that accepts VGA, DVI, S-Video, Composite (BNC) #MICC160FS..... **3349.95**

LC-80MP / 10MP / 150MP

HD Wide-Angle Starter Series Teleprompters

The best low-cost systems. HD-Wide Angle glass Beam Splitter mirror with adjustable camera riser. No counterweight needed. LC-80 and LC-10 can reverse image internally. Includes EZPrompt software, 25' VGA cable and controller.



LC-80MP 8" LCD panel input VGA, NTSC/PAL #MILC80MP..... **1949.95**
LC-10MP 10" LCD panel input XGA #MILC10MP... **1999.95**
LC-150MP 15" LCD panel nput SVGA #MILC150MP **1999.95**

FS-150MP / FS-160

Free Standing Prompters

No need to purchase a heavier duty tripod to support these prompters. Just slide your existing camera/tripod configuration behind and into the fabric hood and start prompting. Systems include a stand, LCD monitor, glass beam splitter, housing, EZ Prompt software, VGA cable and mouse controller.



FS-150MP Input XVGA (300 NTS) #MIFS150MP..... **2199.95**
FS-160 Input XVGA/NTSC/S-Video #MIFS160..... **3624.95**

LC-110 LC-160 / 160HB / OS-160

LC Pro Series -Broadcast Quality

Top of the Line. Outside capable prompters! Light-tight hood and side shields included. HD-Wide Angle glass Beam Splitter mirror with adjustable camera riser. Never needs a counterweight. Pro monitors include built in reversing ability and accept SVGA, NTSC composite video.



LC-110 10" 450 NTS #MILC110..... **3199.95**
LC-160 15" 450 NTS #MILC160..... **3499.95**
160HB 15" (200-1800 NTS) #MILC160HB..... **4649.95**
OS-160 15" (200-1800 NTS) #MIOS160LCD..... **4679.95**

EZPROMPT / SCRIPT Q

Teleprompter Software

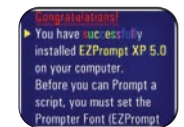

These intuitive, easy-to-use teleprompter programs make management of your text and scripts a breeze. Both will run equally well on laptop and desktop computers.

EZPrompt for Windows XP or most earlier versions #MIEZPSW..... **449.95**
Script Q for Mac OS-X 10.2 or later #MISCRIPQT..... **349.95**

SP-150MP / 160 / 190MP / 220

Speech Series LCD Teleprompters

These complete teleprompter kits are designed for professional speaking venues. Each kit contains 2 LCD monitors, housings, poles and mirrors (EZ Prompt software with the SP-150MP & SP-190MP).

The SP-160-LCD and SP-220-LCD accepts NTSC, PAL, and SVGA video signal inputs.

SP-150MP (2) 15" panels -SVGA signals #MISP150MPLCD..... **2699.95**
SP-160 (2) 15" 2-composite & SVGA inputs #MISP160LCD..... **4899.95**
SP-190MP (2) 19" Panels - SVGA Sig. #MISP190MP.. **3149.95**
SP-220 (2) 19" Pro LCD - Multi Inputs #MISP220LCD. **5499.95**



Autocue QTV

SSP07, 10, 17 & QStart Software

Starter Series Teleprompters and Software Packages

New entry-level product – offers low-cost prompting packages for educational, corporate and religious institutions, small productions and conferences, and home users. The complete packages provide everything you need, pre-assembled for easy installation. The on-camera units can be transformed in to straight-read, floor-standing, free-standing*, or conference units*. Packages include PC and Mac QStart software. (*Additional parts required)



- OCU-SSP07 Starter Series 07 #AUOCUSSP07..... Call
- OCU-SSP10 Starter Series 10" #AUOCUSSP10..... 1598.95
- OCU-SSP17 Starter Series 17" #AUOCUSSP17..... 1898.95

SSPiPhone and iPad Prompters

Starter Series iPhone/iPad Teleprompters

Transform your iPhone or iPad in to a teleprompter using Autocue / QTV's Starter Series hood and mounts with a specially designed cradles in place of the monitor. Simply download a prompter app from the app store, attach your iPhone/iPad and start prompting.



- OCU-SSPiPhone Starter Series iPhone Prompter #AUOCUSSPiPHONE..... Call
- OCU-SSPiPad Starter Series iPad Prompter #AUOCUSSPiPAD Call

Robotic Conference Prompter

Master Series Robotic Executive Speech Prompter

Three-stage robotic conference system with Master Series 17" monitor. Offering the lowest minimum height (43.3") and highest maximum height (83.1"), the robotic stand provides unbeatable flexibility. Stand height controlled via local or remote control, or script markers.



- ESP-ROB/MSP17 Robotic Conference Stand, Local Control and MSP17 Monitor #AU17RSSESPP 8389.95

Manual Conference Prompter

Professional Series Manual Executive Speech Prompter

Lightweight manual conference system with the Professional Series 17" monitor. The height of the stand and the angle of the glass are fully adjustable to match the eyeline of the presenter.



- ESPMSP17 Manual Conference Stand and PSP17 #AUESPMSP17 3932.95

autoscript a clearer picture

15" Entry Level Professional Portable On-Camera Teleprompter

Light-weight economical teleprompter that is an ideal choice for transitioning to a full professional setup. It can be mounted directly onto an Autoscript hood, retaining glass, or mounting assembly. 12v DC power supply is included. Moreover, video inputs include Analog RGB, Component video, Composite video, S-Video, and VGA.



- ELP15-P 15" Portable Teleprompter #AUELP15P..... 3456.95

LED15TFT-FS

LED Prompter (Free-Standing)

Combined LED technology and TFT (thin-film transistor) display to offer a next-generation prompter solution. This model is 15" with a brightness of 1500 Nits that allows it to be viewed from a distance of 15'. This model is also designed specifically for free-standing use and includes hardware designed for that purpose. Built-in tally lights. Illuminated control panel.



- LED15TFT-FS LED Prompter (Free-Standing) #AULED15TFTF 5747.50
- LED19TFT-BLW LED Prompter (Wide-Angle) #LED19TFT-BLW Call

Prompter/People™

UL-IPAD UltraLight iPad Teleprompter

Works with DV and HD cameras and mounts your iPad and camera together for a portable teleprompting solution. Complete with mounting hardware, HD quality glass beamsplitter, abd hood. • Easily readable to over 12 feet • 11.5" (diagonal) Beamsplitter • Adapter available for iPhone™ / iPod Touch™ • Upgradable to 8" LCD prompter • Software is not included, apps are available at the Apple™ AppStore • iPad™ not included



- UL-IPAD UltraLight iPad teleprompter #PRULIPAD 598.95

PRO-D-DSP-17

ProLine StagePro 17" teleprompter pair

Includes 2 teleprompters, distribution amp, cables and Flip-Q Pro software.

- 17" LCD display • Quick-release LCD and glass
- Heavy tip-proof stan • Adjustable height/angle
- Flip-Q Pro for Mac & PC included on USB stick
- PowerFlip reversing Software for Powerpoint
- Monitor moves up for larger/brighter image
- Includes skirt for raised position
- Premium HD 60/40 beamsplitter
- One or two 6.8m / 25 foot SVGA cables
- VGA and composite video inputs
- 12v DC or 100-240v AC



- PRO-D-SP17P ProLine StagePro 17" teleprompter pair #PRSP17 3199.95

Prompter/People™

PRO-D-11 ProLine 11 Teleprompter

Complete teleprompting package designed to work with any mini DV or HD camera and tripod. The system uses an 11" color LCD display with VGA and composite video inputs. The entire setup sits atop the included tripod riser. This package includes several software applications that enhance its performance. Flip-Q Pro is a prompting application for most PC or Mac computers that feature dual-monitor output.



- PRO-D-11 ProLine 11 #PRPL11 1574.95
- PRO-D-15 ProLine 15, Complete Prompter Setup, Monitor, For Mini DV to ENG Cameras. Riser. Mirror Assembly. Prompting Software included #PRPL15... 1749.95
- PRO-D-15HB ProLine 15 High Bright, Complete Prompter Setup, High-Bright Monitor, For Mini DV to ENG Cameras. Riser. Mirror Assembly. Prompting Software #PRPL15HB 3251.95

- PRO-D-17 ProLine 17, Complete Prompter Setup, Monitor, For Mini DV to ENG Cameras. Riser. Mirror Assembly. Prompting Software included #PRPL17 1899.95

FLEX-D-11 Flex 11 TelePrompter

Complete teleprompting package designed to work with any mini DV or HD camera and tripod. The system uses an 11" color LCD display with VGA input. The entire setup sits atop the included tripod riser. This package includes several software applications that enhance its performance. Includes Flip-Q Lite, teleprompting-display, software compatible with PC and Mac platforms. The LCD panel features VGA and composite video inputs, and built-in speakers. Well suited for field or studio use.



- FLEX-D-11 Flex 11 TelePrompter #PRF11..... 1099.95
- FLEX-D-15 Flex 15, Complete Prompter Setup, Monitor, Mounting Hardware, Riser. Mirror Assembly #PRF15. 1299.00
- FLEX-D-17HB Flex 17 High Brightness, Complete Prompter Setup, High-Bright LCD Monitor, Mounting Hardware. Riser. Mirror Assembly. Prompting Software #PRF17HB..... 3794.00
- FLEX-D-17 Flex 17, Complete Prompter Setup, Monitor, Mounting Hardware, Riser. Mirror Assembly #PRF17. 1499.00
- FLEX-D-19 Flex 19, Complete Prompter Setup, Monitor, Mounting Hardware, Riser. Mirror Assembly #PRF19. 1699.00

UL-8 UltraLight 8 TelePrompter

Works with DV and HD cameras and features an 8" HDMI monitor that can also be used for monitoring and playback. Complete with mounting hardware, monitor, HD quality glass beamsplitter, hood and Flip-Q teleprompting software for both Mac and PC. • Easily readable to over 12 feet • Adapter available for iPhone™ / iPod Touch™ and iPad™ • VGA, composite, DVI, HDMI inputs • Fast, easy setup • FREE PC & Mac teleprompter software • Adjustable height camera riser



- UL-8 UltraLight 8 TelePrompter #PRUL8 1099.95



SE-500 / SE-500K

Video Production Switcher

The four-input live production switcher with dual-output video mixer employs real time quad-split preview that includes red, yellow, and green markers to indicate program, preview and other sources, as well as the next selected effect.

- Special effects • Audio mixer
- Tally DB15 and midi connections

SE-500K includes: SE-500, TLM-702 Dual 7" LCD and RKM-572

SE-500 #DASE500	934.95
SE-500KIT #DASE500K1	1844.95



SE-500K



SE-500

SE-800AV / SE-800DV

Digital Video Production Switchers

These full-featured 4-input production video switchers are designed to meet live studio and post-production applications, and feature built-in digital effects, picture-in-picture and chroma key effects. Their color processor and dual channel time base corrector/frame synchronizer assures quality and stable images for each input source. The SE-800DV adds 4 DV (FireWire/i-Link) inputs, plus one SDI overlay input for the use of a digital character generator and full digital output.

SE-800AV 4-Input (S-Video/Composite/Component) #DASE800AV	2459.95
SE-800DV 4 FireWire (DV) inputs & 1 SDI Overlay I/O #DASE800DV	4259.95
SE-800AVK 4 Input Audio Video Mixer Kit, LCD Quad Monitors w/Holder #DASE800AVK1	3794.95
SE-800DVK Digital Video Mixer Kit -4 DV, S-Vid inputs, 4 LCD Monitors #DASE800DVK1	5699.95



SE-900

8-Channel Modular Switchers

The customizable SE-900 modular switcher consists of a control panel and a main frame that holds up to 8 input cards. It accepts a mix of 8 SD inputs including DV, SDI, YUV and composite, and is expandable with additional input cards and accessories. Standard outputs include DV, SDI, YUV, S-Video (Y/C) and composite video. Preview output includes both next source and next effect, enabling preview of any effects before "going live." It features 2 chromakeys with 4 presets, a downstream keyer for easy integration with CG software such as Datavideo CG-100, and SD card for logos.

#DASE900	Call
#DASE900DVK1 DV Kit (6x DV input cards, 2x YUV, CV,S input card +8 In SD Switcher).....	7279.95
#DASE900SDIK1 SDI Production Kit (6x SDI in cards,+8 input SD switcher).....	9194.95



SE-2000 HD/SDI Digital Video Switcher

Designed for small, live production venues of up to 5 inputs by combining 1 or 2 DVI-D computer sources and 3 or 4 HD-SDI sources. HD-SDI inputs may be HD cameras or small HDMI output cameras (with an HDMI to HDSDI converter). CG may be done with the Datavideo CG-350. PowerPoint presentations go right in through the DVI input. The SE-2000's multi display output includes each source, preview, program, and a digital clock display. In addition, the system will store and recall 14 different logos. Built-in audio mixer has four audio follows video inputs (mic or line) and two audio outputs. Works on 12vDC or local power

SE-2000 Video Switcher #DASE2000	4499.95
SE-2000 Kit HD/SDI Video Switcher, RKM-2000, ITC-100B #DASE2000K.....	5799.95
SE-2000 Kit HDR HD/SDI SWITCHER/HDR-50/RKM-2000 #DASE2000KHDR	6734.85



Panasonic AJ-HPM200

HD/SD P2 Mobile Recorder/Player

The most versatile 10-bit, independent frame, 4:2:2 quality HD field recorder on the planet, the AJ-HPM200 can be used with virtually any camera. It offers all of the popular features found in its predecessor, the AJ-HPM110, and adds new functionality including: enhanced cuts editing with separate source and record windows, full-frame rate playback from external disk drives, AVCHD compatibility (with the AJ-YCX250G option card), up-conversion of live video inputs in real time, e-Sata and Giga-bit Ethernet interfaces for expanded network connectivity and 24p Time Code input for production applications, including use as a source for a traditional dailies process.

#PAAJHPM200	Call or Log-on
-------------------	-----------------------



Mobile Video Production Switchers

HS-500 /HS-800

HS-500 includes: SE-500 (4-input) analog audio video, one TLM-702 dual-screen 7" monitor unit, aluminum briefcase-style carrying case #DAHS500.....

2079.95

HS-800 Mobile Studio

Mobile Broadcast Video Management

- Multiple Applications • Quick Setup & Breakdown • Switcher & Mixer • Intercom System
- Monitor Banks • Output Monitor • Breakout Panels #DAHS800



HS-800

HS-500

MS-500 / MS-800AV / MS-800B / MS-900

Mobile Production Switchers



Mobile MS-500 includes: SE-500 mixer, TLM-702 dual 7" monitor unit, TB-5 tally box with 4 tally lights, ITC-100 intercom system with 4 belt packs, headsets, and tally lights, RP-10 lockable pull-out shelf for the SE-500 mixer, PD-1 power distributor, aluminum case #DAMS500. **6294.95**

MS-800AV Mobile Studio 4-input audio-video mixer includes: SE-800 (NTSC) TLM-404 quad-screen LCD monitor, TLM-702 dual-screen monitor, ITC-100 intercom kit with belt packs, headsets and cables for 4 users, PD-1 power distributor, and CCS-M1 aluminum mobile case

MS-800AV Digital Video Switcher #DAMS800AV	11849.95
MS-800B Mobile Studio Kit (NTSC) #DAMS800B	13949.95
MS-900STD Mobile Studio Standard DV Ki #DAMS900STD	16989.95
MS-900DV Mobile Studio DV Kit #DAMS900DV	17199.95
MS-900SDI Mobile Studio SDI Kit #DAMS900SDI	17,787.00

SE-3000 16 Input HD/SD Live Production Switcher

The SE-3000 is a 16 input HD/SD-SDI video switcher with 8 built-in SD to HD up converters. The control panel has an ergonomic LCD touch screen to select EFX, stills, and balanced colors is included, and multi-language support. The SE-3000 has a dual channel multi-viewer, chromakey dual PIP, 3D functions. Full size keyboard is included. Shallow front to back chassis. 40+ wipe patterns, and 80+ DVE transitions. #DASE3000..... **Call**



HS-2000 5-Channel HD Mobile Studio

The HS-2000 is a 5-channel 10-bit 1920 x 1080i or 1280 x 720p HD-SDI and DVI-D video & audio switcher with a 17-inch multi image video monitor displaying each source, together with preview and program. It offers a complete five way intercom system supplied with five belt packs, 14 pre-stored logos, digital clock display, five user set up, title overlay and DVI-D connection ideal for use with presentation software. Integrated audio mixer with balanced XLRs allows up to four mic or line inputs. To avoid the mess and inconvenience of individual power supplies, the HS-2000 comes with an integrated power distribution center that connects all the integrated equipment from a single socket.



#DAHS2000	8294.95
-----------------	----------------

SONY AWS-G500E Anycast Station Live Content Producer

Anycast Station Live Content Producer
The AWS-G500E is a portable live production switcher. This all-in-one unit comprises a high-quality video switcher, an audio mixer, a large LCD display, and a streaming encoder and server. When combined with your choice of optional interface module, it accepts a variety of inputs from PCs, cameras, VCRs and hard disk drives. It mixes audio and offers ME capabilities. This unit will easily integrate into a studio or location live production operation. It comes as a fully configurable system without standard interface modules, allowing users to choose analog or digital, SD and/or HD simply by purchasing the applicable modular BKAW interface cards.

#SOAWSG500E	11899.95
-------------------	-----------------



EDIROL

V4 / V8 Video Production Switcher

The Edirol V-4 and V8 video mixers are powerful, easy to use video mixers capable of switching between multiple cameras or video tape decks during a live performance. They are affordable solutions for houses of worship, schools, and nightclubs. They employ high-quality digital 8-bit, 4:2:2 signal processing, 2 ch TBC frame sync to ensure smooth transitions and stable images.



V4 (Four analog inputs) #EDV4..... **1174.95** **V8** (Eight analog inputs) #EDV8..... **2194.95**

LVS400 Video Production Switcher

The LVS-400 four-input video mixer offers multiple effects, dual bus operation and clean transitions. Logical, simple operational controls facilitate ease of use, with programmable keys to operate in a luminance or chroma superimpose. Supports either NTSC or PAL video signals, and has V-Link MIDI connections to operate w/other Edirol equipment.



#EDLVS400..... **1794.95**

V-440 HD Multi-Format HD/SD Switcher

This 8-input multi-format live switcher is capable of seamless mixing & switching between 4 HD/RGB inputs and 4 SD inputs, no need to obtain separate converters to handle these formats. Features include transition effects, PIP, and upconversion of SD video to HD & RGB with superior image quality. Adjusts 16:9 & 4:3 images, switchable NTSC/PAL. Selectable output formats 1080i or 720p for HDTV or RGB for computer display.



#EDV440HD **8494.95**
V-1600HD Multi-Format Live Video Switcher #EDV1600HD **16,995.00**

LVS-800 Video Mix/Live Switcher

The LVS-800 is an 8-channel standard definition video mixer designed for use in live events or installations demanding ease of use and professional connectivity. It features a downstream keyer (DSK), dual computer inputs, and multiple outputs. Mix between a variety of video sources including scan converters for PC inputs. Each bus can output different sources. Create exciting multi-screen environments for live events. Move from one video source to another using dissolves or wipes. Add a professional touch by moving between sources in a variety of ways. Also offers RS-232 control and Picture-in Picture display. .



#EDLVS800..... **3794.95**

FOR.A HVS-300HS 1M/ E HANABI HD/ SD Video Switcher

• Type B HV-300MU + HVS300U • 1U Rack Height
 • Multiple Control Options • Modular Design
 • Dual PIP Functionality • Keyer with Chroma Key
 #FOHVS300HSB..... **Log-In or Call**



Panasonic

AG-HMX100 Multi-Format HD/SD Digital A/V Mixer

An affordable and versatile HD/ SD audio/video mixer product for schools, government agencies, churches, hotels, and corporate auditoriums, the AG-HMX100 can accept input from both HD-SDI as well as HDMI sources and DVI-I.



The AG-HMX100 can operate as a 3D video switcher with dual SDI signal inputs from 3D cameras. It comes with two pairs of inputs and one pair of output s for 3D video signals. A 3D live switching system can be configured by combining two or more 3D cameras and 3D projector systems. Supports both the simultaneous and side-by-side 3D video output systems. The AGM100 provides audio mixing from the XLR inputs as well as from embedded audio from HD-SDI connections. It also offers a wide range of digital effects and can also switch dual stream 3D sources.

AG-HMX100 #PAAGHMX100 **Call or Log-On**

AV-HS400 HD/SD Multi-Format Switcher

- Works with a variety of Vaddio WallVIEW CCU and PRO PTZ camera systems when used with Vaddio's Precision Camera Controller • 4 HD/SD-SDI inputs and 4 HD-SDI outputs
- Multi-viewing function to output 4, 6, or 10 images from different sources to a single high-resolution display
- Custom cables that easily interface with Vaddio Joystick Controllers • Multi-format compatibility for use in studio or mobile production applications • Advanced features like PIP (Picture-in-Picture), luminance key, aux bus, and downstream key (DSK) functions • Provides 43 transition effects, including 3D digital effects with page turns and rotations, as well as standard wipe, squeeze, and slide patterns



AV-HS400 Switcher Bundle #VAPAVHS400SB **Call or Log-On**
AV-HS04M1 SDI Input Board HD/SD w/SD Upconversion #PAAVHS04M1 **Call or Log-On**
AV-HS04M2 HD/SD Analog Component Input Board #PAAVHS04M2 **Call or Log-On**
AV-HS04M3 DVI Input Board #PAAVHS04M3 **Call or Log-On**
AV-HS04M4 Analog Component Output Expansion Board #PAAVHS04M4 **Call or Log-On**



ScreenPro-II High-Resolution Seamless Switchers

This multi-layer video display system combines seamless switching with a variety of flexible video effects. A versatile video production tool for live event staging and fixed installation applications, it uses four image layers—unscaled background, up to two scaled PIPs or keys, and a downstream key—to produce sophisticated effects.



ScreenPRO-II HD w/enhanced output option #BASP2HDE..... **18047.50**
ScreenPRO-II Controller with Tally/PS2 Card #BASPC2T..... **5994.95**

TRICASTER SERIES

Portable Live Production System

The TriCaster Studio is NewTek's latest portable solution to live TV production. Harness the power of a live TV truck in a compact, 16-pound package; boost live production capabilities with "live virtual sets," multiple component inputs, multiple upstream effects, dual DDRs and animated alpha channels; and expand broadcast production capabilities with real-time delivery from television and Internet streams. The result is an advanced production studio powerful enough to utilize in network environments, yet portable enough to fit in a backpack.

TriCaster VM #NETCVM..... **939.95**
Time Warp #NETCTW **939.95**



	Video Inputs	Video Outputs	Mic Inputs	Line Inputs	Virtual Set Support	16:9 Video Support	Recording Capacity	File Formats & Render Outputs	SKU	Price
TriCaster STUDIO	6 Component, Y/C or Composite	Component, Y/C & Composite	4 Balanced (XLR or Phone)	4 XLR/Phone	Yes (virtual sets included)	Yes	20 hours AVI	AVI, DV, MPEG-2, DVD, QuickTime, MP4 (iPod and PSP)	#NETCSF	8199.00
TriCaster Broadcast	6 Component,	Component, Y/C & Composite							#NETCBF	10249.95