



Quantum Climate Changer Model : CLCP^{Euro} Product Catalogue

0.5 - 27 m³/s
(1000 - 58000 CFM)



IND-PRC002-E4

Contents

Introduction	2
Model Nomenclature	3
Features and Benefits	4
Quick Select	5
50mm Casing Construction	
25mm Casing Construction	
General Data	7
Casing	
Fans and Drives	
Coils	
Filters	
Air Pressure Drop	
Dimensional Data	23
HDT - Unit Dimensions	
HDT - Unit Weight	
VDT - Unit Dimensions	
VDT - Unit Weight	
Installation Consideration	32
Define Unit Left or Right	
Service Clearance	
Coil Connection Dimension	
Fan Outlet Dimension	
Mechanical Specification	36



Introduction

Introduction

Trane have been manufacturing air handling units throughout the world for the past 40 years. This proven world-wide experience enables us to develop a world class air handling unit, the new Quantum Climate Changer. Quantum Climate Changer is a combination of 4 key elements:

1. Globally Integrated Research and Development

A global marketing team comprising air handling specialist from Europe, Asia Pacific and China, Middle East, Africa and South America was formed to provide critical customer and market needs. A global design team comprising design specialist from the Trane Technology Center, USA, Trane Europe and the Trane Air Handling International Development Center in Asia was formed to developed a new world class air handling technology.

2. World Class Manufacturing Facility

The Quantum Climate Changer manufacturing facility is certified to MS ISO 9001 and is one of the earliest American facilities certified to Demand Flow Technologies (DFT). DFT is a technology that takes quality to the people and the machines that produce the product. In addition, Total Quality Control methodology within DFT brings quality into the manufacturing process at the point where work is being performed, resulting in consistent product quality.

3. Performance Assurance and Commitment to Quality

Trane combines comprehensive performance certifications with thorough laboratory testing and manufacturing methods. Together, these elements assure that each Quantum Climate Changer operates predictably and reliably throughout the life of the unit.

4. Matching Technologies to Systems

The building industry is continuously evolving and the rate of change is accelerating. Technologies, economic, regulatory and environmental factors are very different now than there were just a few years ago, which will affect the application and installation of the HVAC systems. Recognizing this and utilizing the Trane worldwide air conditioning system experience, the Quantum Climate Changer was developed and packaged to suit most current air conditioning system application needs.

Purpose

The purpose of this catalogue is to help consulting engineers in the preliminary selection of the Quantum Climate Changer air handling units. Your regional Trane office will assist to provide a computerized selection to confirm or complete your preliminary selection. Where something more special is required, we have full technical support in our regional sales offices and at our factory where non-standard layouts and configurations can be designed to individual requirements.



CLCP_{EURO} Model Nomenclature

eg.: CLCPeuro 0030404DM`FDA0200F`1A1D`A020A11Z
22802`AAA`WLO4144X`WLO4144X`WLO4144X`C

DIGIT	Description
1, 2, 3	CLC = Climate Changer
4	P = Development sequence
5, 6, 7, 8	euro = Eurovent Certified
9, 10, 11	Casing Sizes : 003 / 004 / 006 / 008 / 010 / 012 / 014 / 016 / 020 / 025 / 030 / 035 / 040 / 045 / 050 060 / 065 / 070 / 080 / 085 / 090 / 095
12, 13, 14, 15	Casing parametric dimension: 0404 (003) 1004 (008) 1206 (014) 1210 (025) 1612 (040) 2014 (060) 2614 (080) 3214 (095) 0604 (004) 0806 (010) 1008 (016) 1212 (030) 1812 (045) 2214 (065) 2814 (085) 0804 (006) 1006 (012) 1208 (020) 1412 (035) 2012 (050) 2414 (070) 3014 (090)
16	Insulation: A = 25mm PU Insulation C = 50mm PU Insulation+Stealth Insulator S = Special B = 25mm PU Insulation+Stealth Insulator D = 50 mm Thermal Break (Eurovent)
17	Country of Origin: M = Malaysia C = China
18, 19, 20	Fan Models : FDA ADA BDB BNA ANA SSS = Special XXX = None
21, 22, 23, 24	Fan sizes: 0200 0280 0400 0560 0800 1120 XXXX=None 0225 0315 0450 0630 0900 1250 0250 0355 0500 0710 1000 1400
25	Fan / Bearing Type A=S C=S2 E=SM G=TM I=TX K=S2M M=T2M X=None B=C D=C2 F=CM H=XM J=XX L=C2M N=X2M
26	Fan Arrangement 1=ARR 1 3=ARR 3 5=ARR 5 7=ARR 7 9=ARR 9 B=ARR 11 X=None 2=ARR 2 4=ARR 4 6=ARR 6 8=ARR 8 A=ARR 10 C=ARR 12 5=Special
27, 28	Motor Frame , kW & Pole A1=#63, 0.18kW, 4P, eff2 I1=#112M, 3.7kW, 4P, eff2 Q1=#200L, 30.0kW, 4P, eff2 A2=#63, 0.18kW, 2P, eff2 I2=#112M, 3.7kW, 2P, eff2 B1=#71, 0.37kW, 4P, eff2 J1=#112M, 4.0kW, 4P, eff2 R1=#225S, 37.0kW, 4P, eff2 B2=#71, 0.37kW, 2P, eff2 J2=#112M, 4.0kW, 2P, eff2 C1=#80, 0.55kW, 4P, eff2 K1=#132S, 5.5kW, 4P, eff2 T1=#225M, 45.0kW, 4P, eff2 C2=#71, 0.55kW, 2P, eff2 K2=#132S, 5.5kW, 2P, eff2 D1=#80, 0.75kW, 4P, eff2 L1=#132M, 7.5kW, 4P, eff2 U1=#250S, 55.0kW, 4P, eff2 D2=#80, 0.75kW, 2P, eff2 L2=#132S, 7.5kW, 2P, eff2 E1=#90S, 1.1kW, 4P, eff2 M1=#160M, 11.0kW, 4P, eff2 V1=#250M, 75.0kW, 4P, eff2 E2=#80, 1.1kW, 2P, eff2 M2=#160M, 11.0kW, 2P, eff2 F1=#90L, 1.5kW, 4P, eff2 N1=#160L, 15.0kW, 4P, eff2 W1=#280SC, 90.0kW, 4P, eff2 F2=#90S, 1.5kW, 2P, eff2 N2=#160M, 15.0kW, 2P, eff2 G1=#100L, 2.2kW, 4P, eff2 O1=#180M, 18.5kW, 4P, eff2 Y1=#280MC, 110.0kW, 4P, eff2 G2=#90L, 2.2kW, 2P, eff2 O2=#160L, 18.5kW, 2P, eff2 H1=#100L, 3.0kW, 4P, eff2 P1=#180L, 22.0kW, 4P, eff2 Z1=#315SC, 132.0kW, 4P, eff2 H2=#100L, 3.0kW, 2P, eff2 P2=#180M, 22.0kW, 2P, eff2 A3=#63, 0.18kW, 4P, eff1 I3=#112M, 3.7kW, 4P, eff1 Q3=#200L, 30.0kW, 4P, eff1 A4=#63, 0.18kW, 2P, eff1 I4=#112M, 3.7kW, 2P, eff1 B3=#71, 0.37kW, 4P, eff1 J3=#112M, 4.0kW, 4P, eff1 R3=#225SC, 37.0kW, 4P, eff1 B4=#71, 0.37kW, 2P, eff1 J4=#112M, 4.0kW, 2P, eff1 C3=#80, 0.55kW, 4P, eff1 K3=#132S, 5.5kW, 4P, eff1 T3=#225M, 45.0kW, 4P, eff1 C4=#71, 0.55kW, 2P, eff1 K4=#132S, 5.5kW, 2P, eff1 D3=#80, 0.75kW, 4P, eff1 L3=#132M, 7.5kW, 4P, eff1 U3=#250S, 55.0kW, 4P, eff1 D4=#80, 0.75kW, 2P, eff1 L4=#132S, 7.5kW, 2P, eff1 E3=#90S, 1.1kW, 4P, eff1 M3=#160M, 11.0kW, 4P, eff1 V3=#250M, 75.0kW, 4P, eff1 E4=#80, 1.1kW, 2P, eff1 M4=#160M, 11.0kW, 2P, eff1 F3=#90L, 1.5kW, 4P, eff1 N3=#160L, 15.0kW, 4P, eff1 W3=#280SC, 90.0kW, 4P, eff1 F4=#90S, 1.5kW, 2P, eff1 N4=#160M, 15.0kW, 2P, eff1 G3=#100L, 2.2kW, 4P, eff1 O3=#180M, 18.5kW, 4P, eff1 Y3=#280MC, 110.0kW, 4P, eff1 G4=#90L, 2.2kW, 2P, eff1 O4=#160L, 18.5kW, 2P, eff1 H3=#100L, 3.0kW, 4P, eff1 P3=#180L, 22.0kW, 4P, eff1 Z3=#315SC, 132.0kW, 4P, eff1 H4=#100L, 3.0kW, 2P, eff1 P4=#180M, 22.0kW, 2P, eff1 XX=None SS = Special
29	Electrical rating of motor : Volt/Phase/Hz. D=380 - 415 V / 3 Ph / 50 Hz E=200V / 3 Ph / 50 Hz F=230V / 3 Ph / 60 Hz G=380V / 3 Ph / 60 Hz H=440V / 3 Ph / 60 Hz J=460V / 3 Ph / 60 Hz K=480V / 3 Ph / 60 Hz L= 200V / 3Ph / 60Hz X=None
30	Fan Pulley Size
31, 32, 33	Fan shaft diameter
34	Motor Pulley Size
35, 36	Motor shaft diameter
37	Belt type A=SPA B=SPB C=SPC Z=SPZ X=None
38, 39, 40, 41	Belt length, - - - mm
42	Pulley Grooves 1=1Groove 2=2Groove 3=3Groove 4=4Groove 5=5Groove X=None
43	Pre-Filter Media A=2"Pleated 30% B=2"Washable 20% C=2" Aluminum D=4"Pleated 30% E=Hepa 99.97% S=SPECIAL X=None
44, 45	Filter Media # 1 , Filter Media # 2 A=2"Pleated 30% F=Hepa 99.99% K=4"Cartridge 85% L=4"Cartridge 95% M=21" Bag 60-65% N=21" Bag 85% O=21"Bag 95% B=2"Washable 20% G=15" Bag 60-65% H=15" Bag 85% I=15" Bag 95% J=4"Cartridge 65% P=12"Cartridge 65% Q=12"Cartridge 85% R=12"Cartridge 95% S=Carbon T=Special Media U=Biocell V=PTFE X=None
46	Coil Section # 1 , Type : W = WL (1/2"Tube) ; L = LL(1/2"Tube) ; D = DL(1/2"Tube) ; F =FD(1/2"Tube) ; A = A(1/2"Tube) ; B = AA(1/2"Tube) , S = Special , X = Without Coil
47	Coil Connection : L = LH Side R = RH Side B = Both Sides X = None
48, 49	Coil Rows : 01=1row 02= 2row 04= 4row 06= 6row 08= 8row 10= 10row 12= 12row XX = without coil
50, 51, 52	Coil Fin Series(FPF) : 100 - 168 Fins per Foot XXX = without coil SSS= Special
53	Coil Turbulator : X = No Y = Yes
54	Coil Section # 2 , Type W = WL (1/2"Tube) ; L = LL(1/2"Tube) ; D = DL(1/2"Tube) ; F =FD(1/2"Tube) ; A = A(1/2"Tube) ; B = AA(1/2"Tube) , S = Special , X = Without Coil
55	Coil Connection : L = LH Side R = RH Side B = Both Sides X = None
56, 57	Coil Rows : 01=1row 02= 2row 04= 4row 06= 6row 08= 8row 10= 10row 12= 12row XX = without coil
58, 59, 60	Coil Fin Series(FPF) : 100 - 168 Fins per Foot XXX = without coil SSS= Special
61	Coil Turbulator : X = No Y = Yes
62	Coil Section # 3 , Type W = WL (1/2"Tube) ; L = LL(1/2"Tube) ; D = DL(1/2"Tube) ; F =FD(1/2"Tube) ; A = A(1/2"Tube) ; B = AA(1/2"Tube) , S = Special , X = Without Coil
63	Coil Connection : L = LH Side R = RH Side B = Both Sides X = None
64, 65	Coil Rows : 01=1row 02= 2row 04= 4row 06= 6row 08= 8row 10= 10row 12= 12row XX = without coil
66, 67, 68	Coil Fin Series(FPF) : 100 - 168 Fins per Foot XXX = without coil SSS= Special
69	Coil Turbulator : X = No Y = Yes
70	Service digit, C = present



Features and Benefits

Ultra Low Leak Construction

Unique casing design with panel attached to the frame through a selflocking mechanism represented by a wedge and frame, exerting pressure evenly onto the panel and the seal attached to the frame, and hence a better air tight cabinet construction. The casing is designed to meet Eurovent Casing Air Leakage Standard.

Excellent Condensate Management

Dual pitched sloping drain pan allows for total condensate removal. A unique feature developed to prevent stagnant water in air handling units.

Environmental Friendly Materials

High-grade aluminium frame is non-corrosive and is easily clean-able. All these features will further enhance indoor air quality.

Design for Routine Cleaning

Double wall panel construction allows for easy cleaning and disinfecting of the interior surfaces. Panel and frame design allows for easy removal of side panels for maximum access to internal areas.

High Grade Aluminum Frame

Frame is constructed of extruded aluminum channels for structural rigidity and lightness.

Injected Polyurethane Foam Panels

All panels are injected with high efficiency polyurethane foam insulation. Foamed panels provide superior thermal resistance properties, and have excellent acoustic and vibration absorption characteristics. In addition, polyurethane foam does not absorb moisture and will not promote fungus growth.

High Efficiency Performance

Patented Delta-Flo slit heat transfer technology gives maximum cooling and dehumidification. Trane engineered fan systems provide maximum airflow while minimizing vibration, acoustic levels and power consumption.

Suitable for Retrofit Renovation and Replacement

Change is inevitable. As time passes, building loads alter, new technologies emerge and codes and standards are revised. The Quantum Climate Changer design lends itself to the needs of the renovation, retrofit and replacement market.

Sturdy Unit Construction

The Quantum Climate Changer's flexibility is contributed by the structural integrity pentapost and panel construction. That not only means you can stack modules in a space-saving vertical air-handler configuration, but also allows removal of panels for unlimited access. The casing strength is designed to meet European Standard EN 1886:1998.

Optimized Coils

Flexibility characterizes the Quantum Climate Changer's broad coil offering. The variety of types, sizes, arrangements and materials enables you to select a coil optimized for the application pressure drop and capacity requirements. Options include;

- 2 to 12 rows, ½ inch OD chilled water coils and two separate cooling coil in series to meet high capacity requirement.
- One and two rows, ½ inch OD hot water coils.
- Four and six rows, ½ inch OD refrigerant coils.

- One row ½ inch OD, distributing type steam coils.
- Infinitely variable fin spacing (IVS).
- Stainless steel coil casing (option). Copper fins.
- Coated aluminum fin for corrosion resistance.
- Header drain and vent connections.
- Fully drain able coils at header.

All standard heating and cooling coils are engineered and manufactured at Trane air handling systems manufacturing facility.

Performance Assurance and Commitment to Quality

Trane combines comprehensive performance certifications with thorough laboratory testing and manufacturing methods. Together these elements help to ensure that each Quantum Climate Changer operates predictably and reliably throughout the life of the unit. All fans are tested as per ANSI/AMCA 210, ANSI/ASHRAE Standard 51 - Laboratory Method of Testing Fans for Rating" and AMCA 300 "Reverberant Room Method for Sound Testing of Fans."

All coil capacities, pressure drops and selection procedures are rated in accordance to ARI Standard 410. All coils are leak and proof tested to min 375 psig.

Quantum Climate Changer is manufactured in a facility that is certified to MS ISO9001.



Quick Select 50mm Casing Construction

Quick Selection Procedure

Step 1: Determine what is the design airflow (m³ / s) or total cooling capacity (kW).

Step 2: Use the table below to determine the unit size by picking the closest airflow or total cooling capacity.

Step 3: The unit width and height are the same for all sections. Unit length in Table A is based on basic fan+coil+flat filter sections only.

For other combinations, use Table B: Standard Section Length to determine the overall unit length.

Step 4: Determine the nominal unit details (unit weight, coil water pressure drop, water flow rate and motor installed power) using Table A.

Table A: Quick Select

Model Size	Coil Face Area	Airflow At 2.5m/s Face Velocity	Total Cooling Capacity	External Static Pressure	Unit Dimension (Fan + Coil + Flat Filter)			Unit Weight	Cooling Coil Water Pressure Drop	Water Flow Rate	Motor Installed Power
	m ²	m ³ / s	kW	Pa	Width mm	Height mm	Length mm	kg	kPa	L / s	kW
003	0.24	0.6	11	300	748	868	1368	160	1.5	0.48	1.50
004	0.40	1.0	22	300	1058	868	1368	200	3.7	0.94	1.50
006	0.57	1.4	22	300	1368	868	1523	260	1.7	0.96	2.20
008	0.73	1.9	36	300	1678	868	1523	300	4.7	1.53	3.00
010	0.90	2.3	41	300	1368	1178	1523	330	3.6	1.75	4.00
012	1.16	3.0	60	300	1678	1178	1678	420	8.6	2.60	4.00
014	1.42	3.6	79	300	1988	1178	1678	470	15.8	3.41	5.50
016	1.59	4.1	81	300	1678	1488	1678	530	6.9	3.49	5.50
020	1.95	5.0	107	500	1988	1488	1833	700	12.9	4.60	11.00
025	2.40	6.2	137	500	1988	1798	1833	750	18.3	5.89	11.00
030	2.90	7.4	160	500	1988	2108	1988	850	14.7	6.89	11.00
035	3.43	8.7	197	500	2298	2108	2143	990	23.9	8.48	15.00
040	3.97	10.1	235	500	2608	2108	2298	1150	36.0	10.10	15.00
045	4.50	11.5	272	500	2918	2108	2298	1250	51.1	11.70	18.50
050	5.04	12.9	309	500	3228	2108	2453	1460	70.0	13.33	22.00
060	5.95	15.2	364	500	3228	2418	2608	1870	68.4	15.66	30.00
065	6.58	16.8	406	750	3538	2418	2763	2110	78.8	17.61	37.00
070	7.21	18.4	410	750	3848	2418	2763	2210	25.9	17.22	37.00
080	7.85	20.0	444	750	4158	2418	2763	2450	32.6	19.11	45.00
085	8.48	21.6	487	750	4468	2418	2763	2570	39.9	20.94	45.00
090	9.11	23.2	532	750	4778	2418	2763	2840	48.5	22.90	55.00
095	9.78	24.9	568	750	5088	2418	2763	2940	46.0	24.47	55.00

Note:

1. Nominal cooling capacities are based on EDB 26.7°C / EWB 19.4°C and EWT 6.7°C / LWT 12.2°C.

2. Unit dimension and weight includes forward curved fan section (arrangement 1 and 2), 4row 120ft coil (1/2inch cu tube) section and flat filter section (with filter media).

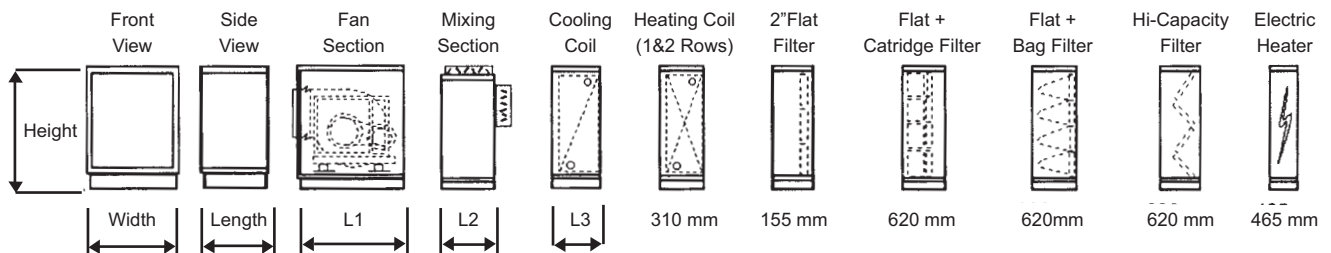

Fan Section, L1 (arrangement 1 and 2, motor installed power as per Table A)

Model Size	003	004	006	008	010	012	014	016	020	025	030
Length, mm	775	775	930	930	930	1085	1085	1085	1240	1240	1240
Model Size	035	040	045	050	060	065	070	080	085	090	095
Length, mm	1395	1550	1550	1705	1860	2015	2015	2015	2015	2015	2015

Mixing Section, L2

Model Size	003	004	006	008	010	012	014	016	020	025	030
Length, mm	310	310	310	310	465	465	465	465	465	465	620
Model Size	035	040	045	050	060	065	070	080	085	090	095
Length, mm	620	620	620	620	930	930	1085	1085	1240	1240	1240

Coil Section, L3

Model Size	003 - 025	030 - 095
1 and 2 row	310mm	310mm
4 row	310mm	465mm
6 row	465mm	465mm
8, 10 and 12 row	620mm	620mm

Note:

1. Total unit length shall be calculated based on total sum of all the individual section lengths added together.

2. Add 128mm to overall unit length for end frame for all models.

3. Fan section lengths are indicative only as the length varies according to the fan arrangement and motor kW range.

4. Add another 155mm section for unit with fan and coil sections only.

Quick Select 25mm Casing Construction

Quick Selection Procedure

Step 1: Determine what is the design airflow (m³ / s) or total cooling capacity (kW).

Step 2: Use the table below to determine the unit size by picking the closest airflow or total cooling capacity.

Step 3: The unit width and height are the same for all sections. Unit length in Table A is based on basic fan+coil+flat filter sections only.

For other combinations, use Table B: Standard Section Length to determine the overall unit length.

Step 4: Determine the nominal unit details (unit weight, coil water pressure drop, water flow rate and motor installed power) using Table A.

Table A: Quick Select

Model Size	Coil Face Area	Airflow At 2.5m/s Face Velocity	Total Cooling Capacity	External Static Pressure	Unit Dimension (Fan + Coil + Flat Filter)			Unit Weight	Cooling Coil Water Pressure Drop	Water Flow Rate	Motor Installed Power
	m ²	m ³ / s	kW	Pa	Width mm	Height mm	Length mm	kg	kPa	L / s	kW
003	0.24	0.6	11	300	698	818	1318	136	1.5	0.48	1.50
004	0.40	1.0	22	300	1008	818	1318	168	3.7	0.94	1.50
006	0.57	1.4	22	300	1318	818	1473	214	1.7	0.96	2.20
008	0.73	1.9	36	300	1628	818	1473	257	4.7	1.53	3.00
010	0.90	2.3	41	300	1318	1128	1473	279	3.6	1.75	4.00
012	1.16	3.0	60	300	1628	1128	1628	354	8.6	2.60	4.00
014	1.42	3.6	79	300	1938	1128	1628	404	15.8	3.41	5.50
016	1.59	4.1	81	300	1628	1438	1628	451	6.9	3.49	5.50
020	1.95	5.0	107	500	1938	1438	1783	524	12.9	4.60	11.00
025	2.40	6.2	137	500	1938	1748	1783	638	18.3	5.89	11.00
030	2.90	7.4	160	500	1938	2058	1938	739	14.7	6.89	11.00
035	3.43	8.7	197	500	2248	2058	2093	843	23.9	8.48	15.00
040	3.97	10.1	235	500	2558	2058	2248	992	36.0	10.10	15.00
045	4.50	11.5	272	500	2868	2058	2248	1080	51.1	11.70	18.50
050	5.04	12.9	309	500	3178	2058	2403	1265	70.0	13.33	22.00

Note:

1. Nominal cooling capacities are based on EDB 26.7°C / EWB 19.4°C and EWT 6.7°C / LWT 12.2°C.

2. Unit dimension and weight includes forward curved fan section 4row 120ft coil (1/2inch cu tube) section and flat filter section (with filter media).

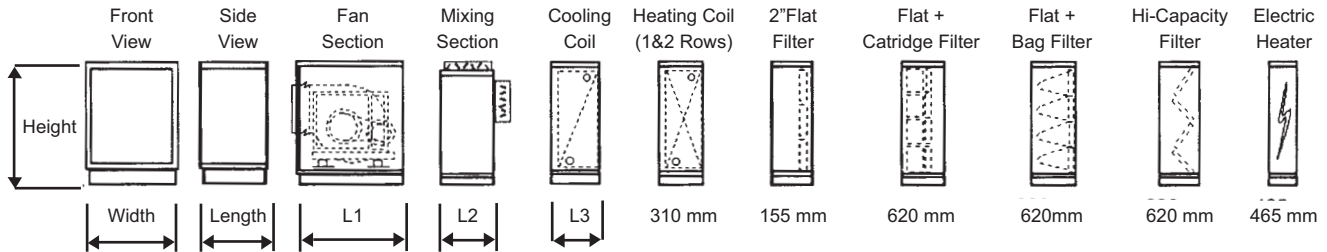

Fan Section, L1 (arrangement 1 and 2, motor installed power as per Table A)

Model Size	003	004	006	008	010	012	014	016	020	025	030
Length, mm	775	775	930	930	930	1085	1085	1085	1240	1240	1240
Model Size	035	040	045	050	060	065	070	080	085	090	095
Length, mm	1395	1550	1550	1705	1860	2015	2015	2015	2015	2015	2015

Mixing Section, L2

Model Size	003	004	006	008	010	012	014	016	020	025	030
Length, mm	310	310	310	310	465	465	465	465	465	465	620
Model Size	035	040	045	050	060	065	070	080	085	090	095
Length, mm	620	620	620	620	930	930	1085	1085	1240	1240	1240

Coil Section, L3

Model Size	003 - 025	030 - 050
1 and 2 row	310mm	310mm
4 row	310mm	465mm
6 row	465mm	465mm
8, 10 and 12 row	620mm	620mm

Note:

1. Total unit length shall be calculated based on total sum of all the individual section lengths added together.

2. Add 78mm to overall unit length for end frame for all models.

3. Fan section lengths are indicative only as the length varies according to the fan arrangement and motor kW range.

4. Add another 155mm section for unit with fan and coil sections only.

General Data Casing

Casing Type

- The extruded frame of engineering grade aluminium provides the Quantum™ Climate Changer™ with excellent rigidity.
- Casing strength is designed to meet European standard EN 1886:1998.
- The panel is attached to the frame through a self locking mechanism represented by a wedge and frame, exerting pressure evenly onto the panel and the seal attached to the frame, and hence a better air tight cabinet construction. This unique design requires no welding during assembly of the framework sections.
- The panels are of double wall construction and injected with foam insulation to provide a rigid, sturdy and easily cleaned enclosure.
- Access panels are easily and quickly removed for maintenance and cleaning.
- Quantum™ Climate Changer™ is designed to suit the technical requirement of each application. This flexibility in design is especially suitable for replacement projects.

Panel Thickness:

Overall average panel nominal thickness shall be 25 & 50mm.

The exterior and inner wall's panel coating comes with a variety of choices.

- Standard offering: Baked polyester powder painted steel sheet on exterior wall and galvanized steel sheet on inner wall.
- Option: Baked polyester powder painted steel sheet on exterior and inner-wall.

Panel

The panels are manufactured by injection of polyurethane foam insulation between two metal skins to produce a rigid and totally enclosed panel of 25mm and 50mm nominal thickness.

This double wall construction keeps the insulation out of the airstream and contributes towards improved indoor air quality. The panels are also easily cleaned.

Insulating Material Specification:

Thermal conductivity 'K' factor = 0.02 W/m²K.

General Data Fans and Drives

Fan

Type of Fans

Quantum™ Climate Changer™ air handling units are designed to provide accurate performance in order to meet the sophisticated building air conditioning requirement.

Quantum™ Climate Changer™ air handling units are supplied with double inlet, double width (DIDW) centrifugal blowers.

- Forward curved blade (FC)
- Backward curved blade (BC)
- Airfoil blade (AF) upon request
- Direct / belt Drive plenum / plug fan upon request

Construction

- Fan casing are constructed of galvanized steel with a series of punched holes or nutserts allowing the fixing of accessories such as frames or support structure thus providing a variety of discharge positions.
- The impeller (blade) is galvanized steel finish for FC and painted steel for backward curved and securely fixed to the solid straight shaft.
- All fan impellers are statically and dynamically balanced by the ISO 1940 and AMCA 204/3-G2.5 quality.
- Fan shaft are carbon steel (C45) grade and machined to tolerances of ISO 286-2. Grade G6 standard.

Vibration Isolator

Three types of isolators used are:

- Rubber In-shear
- 1" Deflection Spring
- 2" Deflection Spring

General Data Fan & Drives

Fan Size and Diameter

Model Size	Fan Size	Fan Wheel Diameter (mm)
003	FC 200	200
	BC 200	200
004	FC 225	225
	BC 225	225
006	FC 250	250
	BC 250	250
008	FC 280	280
	BC 280	280
010	FC 315	315
	BC 315	315
012	FC 400	400
	BC 400	400
014	FC 400	400
	BC 400	400
016	FC 450	450
	BC 450	450
020	FC 500	500
	BC 500	500
025	FC 560	560
	BC 560	560
030	FC 560	560
	BC 560	560
035	FC 630	630
	BC 630	630
040	FC 710	710
	BC 710	710
045	FC 710	710
	BC 710	710
050	FC 800	800
	BC 800	800
060	FC 800	800
	BC 800	800
065	FC 900	900
	BC 900	900
070	FC 900	900
	BC 900	900
080	FC 1000	1000
	BC 1000	1000
085	FC 1000	1000
	BC 1000	1000
090	FC 1000	1000
	BC 1000	1000
095	FC 1000	1000
	BC 1000	1000

Fan Discharge Arrangements

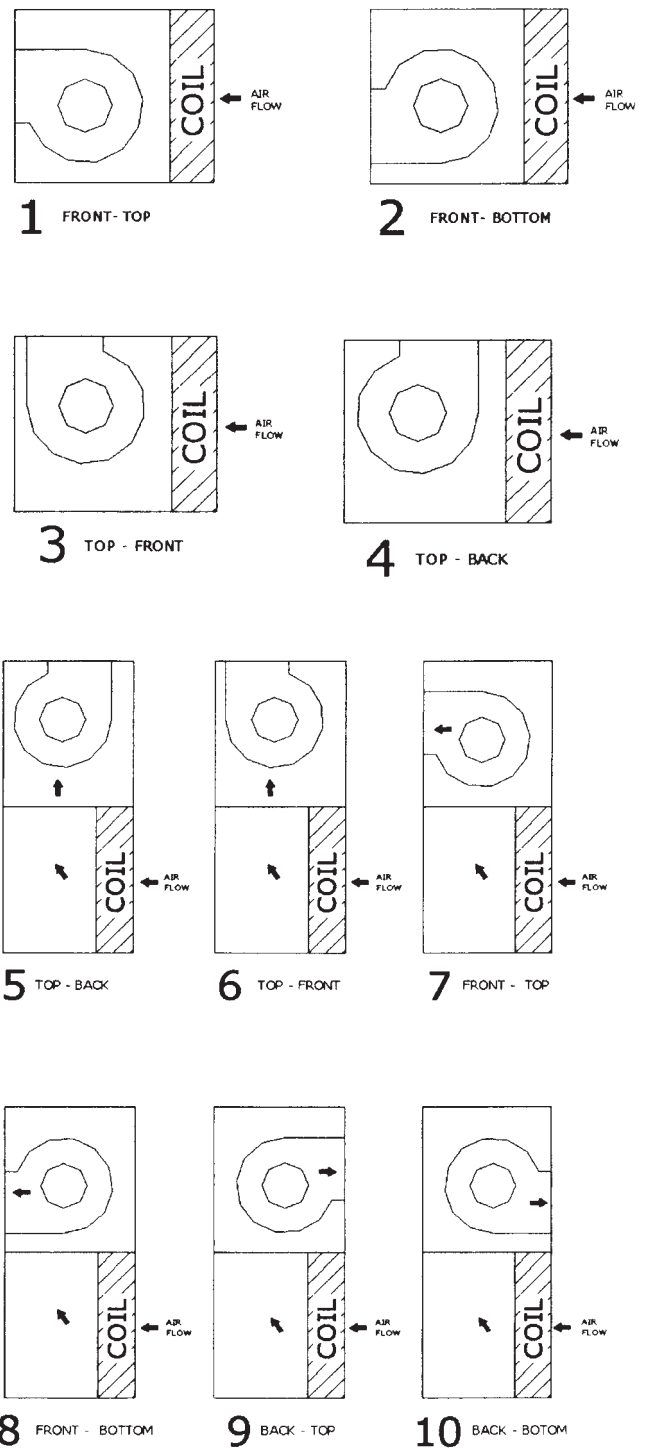

General Data Fans and Drives

Fan Series

KAT Series - Double Inlet Forward Curved Centrifugal Fans

The KAT fan series is Double Inlet Double Width (DIDW) centrifugal fans with forward curved impellers. The fans are suitable for supply or extract application in commercial, process and industrial HVAC systems.

The KAT series is available in type S and C as shown in Fig.1.

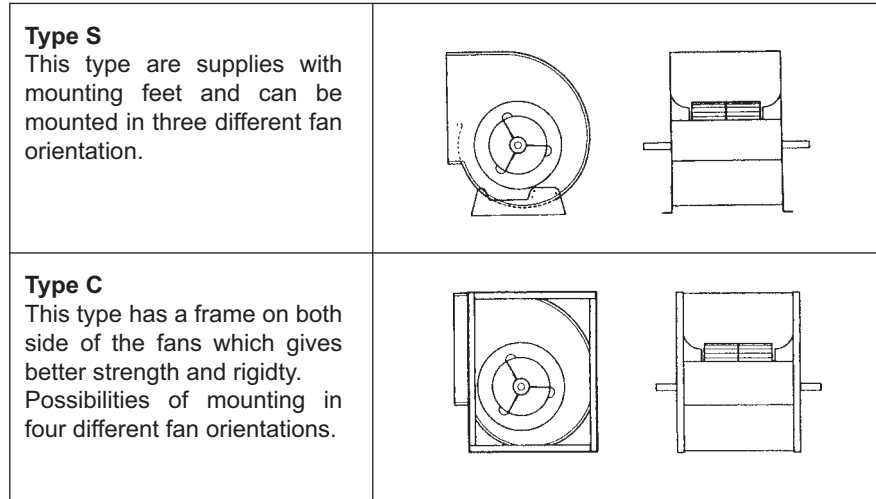

Fig. 1

FC & BC Series - Double Inlet Forward Curved and Backward Curved Centrifugal Fans

The FC and BC series is DIDW centrifugal fans with forward curved and backward curved impeller. The fans are suitable for supply or extract applications in commercial, process and HVAC systems. The FC and BC series is available in type S, C, T or X as shown in Fig.2.

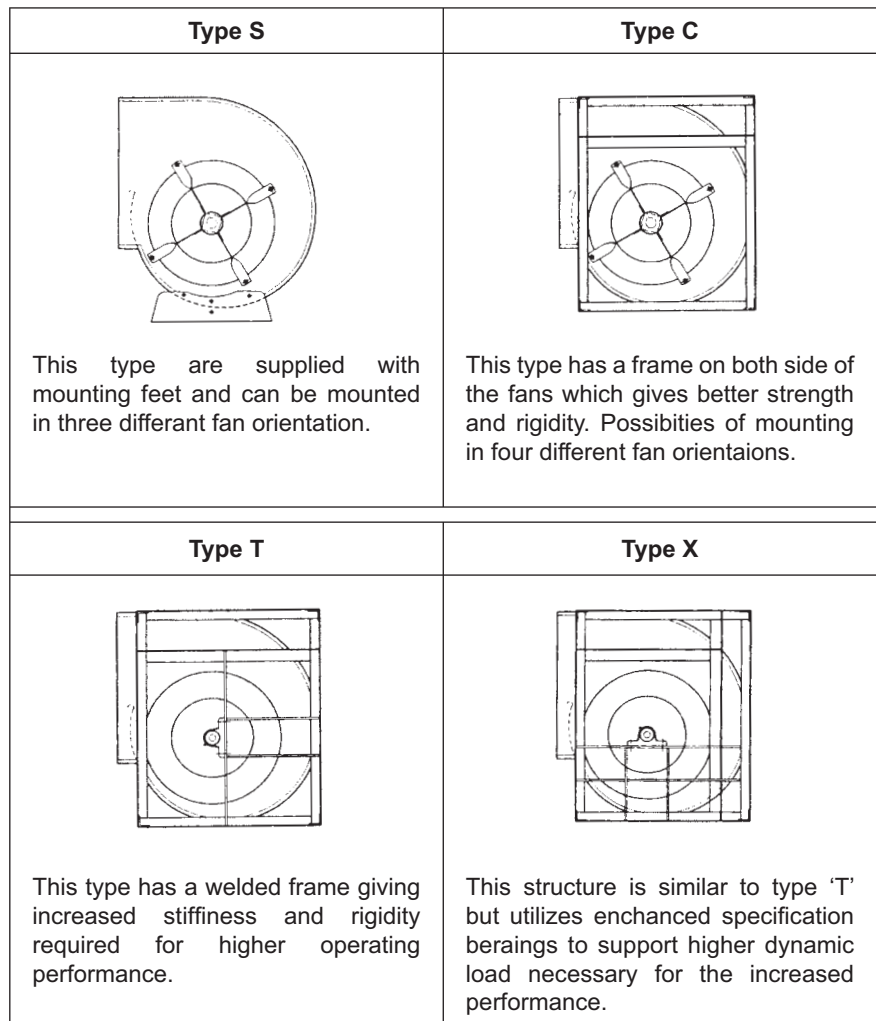

Fig. 2

General Data Coils

Coils

General

- The cooling coil shall be mounted over the dual pitched sloping drain pan to ensure water condensate flowing.
- Coil performances are designed in accordance to ARI Standard 410.
- All coils shall be counter flow design.
- The Delta Flo coils design that shall have the following criteria as above.

Description	Refrigerant (FD)	Chilled Water	Hot Water
Face Velocity; FPM (m/s)	200 ~ 800 (1.0~4.1)	200 ~ 800 (1.0~4.1)	200 ~ 1500 (1.0~457)
EDB; ° F (° C)	65 ~ 100 (18 ~ 38)	65 ~ 100 (18 ~ 38)	0 ~ 100 (18 ~ 38)
EWB; ° F (° C)	60 ~ 85 (15~29)	60 ~ 85 (15 ~ 29)	–
EWT; ° F (° C)	–	35 ~ 65 (2 ~ 38)	120 ~ 250 (49 ~ 121)
Water Velocity; Ft/s (m/s)	–	1 ~ 8 (0.31 ~ 2.4)	0.5 ~ 8 (0.15 ~ 24)
Saturated Suction Temperature; ° F (° C)	34 ~ 55 (1.1 ~ 12.8)	–	–
Minimum Superheat; ° F (° C)	6 (14)	–	–

Availability

Water, Refrigerant and Steam Coil

Coil Type	Description	Rows	End Connection	Header Material	Fins Per Foot	Tube Material	Max. Standard operation Pressure (Tube Side)			
							Pressure		Temp.	
							Psig	kPa	° F	° C
WL	General Purpose Single-Row Serpentine Water Coil	2,4,6,8, 10 & 12	Same Side	Steel Or Copper	Aluminum 96 - 168 Htg 96 - 168 Clg Copper 120 - 168	1/2" OD Copper	250	1724	220	104
DL	Drainable Double-Row Serpentine Water Coil	2,4,6,8, 10 & 12	Same Side	Steel Or Copper	Aluminum 96 - 168 Htg copper 96 - 168 Clg Copper 120 - 168 Htg 120 - 168 Clg	1/2" OD Copper	250	1724	220	104
LL	Drainable Double-Row Serpentine Water Coil	4,6,8, 10 & 12	Same Side	Steel Or Copper	Aluminum 96 - 168 Clg Copper 120 - 168 Clg	1/2" OD Copper	250	1724	220	104
FD	Refrigerant Cooling Coil	4,6	Same Side	Copper	Aluminum 96 - 168 Clg Copper 120 - 168 Clg	1/2" OD Copper	250	1724	220	104
A or AA	Steam Coil	1	Opposite Side	Steel	Aluminum 96 - 168	1/2" OD Copper	250	1724	220	104

1. All coil length are available in 1inch increments.
2. All fin spacing are available in 1 fin per foot increments
3. Turbulators are available for type WL and LL coils. This option is useful when water velocities are low (less than 4 ft/ sec) to obtain maximum tube side heat transfer. The use of turbulators is equivalent to doubling the water velocity though the tubes.
4. All water coils can be used in cooling and heating applications.
5. Circuiting options for type FD coils are: Standard (Single Distributor), and Intertwined circuiting.



General Data Coils

Chilled and Hot Water Coil

Dimensions

Model Size	Coil Face Area		Actual Fin Height		Finned Length	
	Ft ²	M ²	in	mm	in	mm
003	2.5	0.24	21	533	17	432
004	4.3	0.40	21	533	29	737
006	6.1	0.57	21	533	41	1041
008	7.9	0.73	21	533	53	1346
010	9.7	0.90	34	864	41	1041
012	12.5	1.16	34	864	53	1346
014	15.3	1.42	34	864	65	1651
016	17.1	1.59	46	1175	53	1346
020	21.0	1.95	46	1175	65	1651
025	26.0	2.40	58	1473	65	1651
030	31.5	2.93	70	1778	65	1651
035	37.3	3.47	70	1778	77	1956
040	43.2	4.02	70	1778	89	2261
045	49.0	4.56	70	1778	101	2565
050	54.8	5.10	70	1778	113	2870
060	64.0	5.95	40	1016	113	2870
			41	1041	113	2870
065	70.8	6.58	40	1016	125	3175
			41	1041	125	3175
070	77.6	7.21	40	1016	137	3480
			41	1041	137	3480
080	84.4	7.85	40	1016	149	3785
			41	1041	149	3785
085	91.1	8.48	40	1016	161	4089
			41	1041	161	4089
090	97.9	9.11	40	1016	173	4394
			41	1041	173	4394
095	104.5	9.78	40	1016	185	4699
			41	1041	185	4699



General Data Coils

Steam Coil Dimension (1/2" Delta Flo; Type A and AA Circuiting)

Dimensions

Model Size	Coil Face Area		Actual Fin Height		Finned Length	
	Ft ²	M ²	in	mm	in	mm
003	2.1	0.20	20	508	15	381
004	2.4	0.23	20	508	17	432
006	5.4	0.50	20	508	39	991
008	7.1	0.66	20	508	51	1295
010	8.8	0.82	32.5	826	39	991
012	11.5	1.07	32.5	826	51	1295
014	14.2	1.32	32.5	826	63	1600
016	14.2	1.32	20	508	51	1295
			20	508	51	1295
020	17.6	1.64	20	508	63	1600
			20	508	63	1600
025	23.0	2.14	32.5	826	63	1600
			20	508	63	1600
030	28.4	2.64	32.5	826	63	1600
			32.5	826	63	1600
035	33.8	3.14	32.5	826	75	1905
			32.5	826	75	1905
040	39.2	3.65	32.5	826	87	2210
			32.5	826	87	2210
045	44.6	4.15	32.5	826	99	2515
			32.5	826	99	2515
050	50.2	4.66	32.5	826	111	2819
			32.5	826	111	2819
060	57.8	5.38	20	508	111	2819
			20	508	111	2819
			35	889	111	2819
065	64.1	5.96	20	508	123	3124
			20	508	123	3124
			35	889	123	3124
070	70.4	6.55	20	508	135	3429
			20	508	135	3429
			35	889	135	3429
080	78.5	7.11	20	508	147	3734
			20	508	147	3734
			35	889	147	3734
085	82.8	7.70	20	508	159	4039
			20	508	159	4039
			35	889	159	4039
090	89.2	8.30	20	508	171	4343
			20	508	171	4343
			35	889	171	4343
095	95.3	8.86	20	508	183	4648
			20	508	183	4648
			35	889	183	4648



General Data Coils

Refrigerant Coil Circuits (1/2" Standard Refrigerant Coil Circuiting)

Dimensions

Model Size	Coil Face Area		Actual Fin Height		Finned Length		No. of Dist	Fin Height	Piping Ø		
	Ft ²	M ²	in	mm	in	mm			Liquid		Suction
									1/4"	3/16"	O.D.
003	2.5	0.23	21	533	17	432	1	–	28.6	22.2	41.2
004	4.3	0.40	21	533	29	737	1	–	28.6	22.2	41.2
006	6.1	0.56	21	533	41	1041	1	–	28.6	22.2	41.2
008	7.9	0.73	21	533	53	1346	1	–	28.6	22.2	41.2
010	9.7	0.90	34	864	41	1041	1	–	35	28.6	41.2
012	12.5	1.16	34	864	53	1346	1	–	35	28.6	41.2
014	15.3	1.42	34	864	65	1651	1	–	35	28.6	41.2
016	–	–	–	–	–	–	–	–	–	–	–
020	–	–	–	–	–	–	–	–	–	–	–
025	–	–	–	–	–	–	–	–	–	–	–
030	31.5	2.93	70	1778	65	1651	2	70	35	28.6	41.2
035	37.3	3.47	70	1778	77	1956	2	70	35	28.6	41.2
040	43.2	4.02	70	1778	89	2261	2	70	35	28.6	41.2
045	49.0	4.56	70	1778	101	2565	2	70	35	28.6	41.2
050	54.8	5.10	70	1778	113	2870	2	70	35	28.6	41.2
060	–	–	–	–	–	–	–	–	–	–	–
065	–	–	–	–	–	–	–	–	–	–	–
070	–	–	–	–	–	–	–	–	–	–	–
080	–	–	–	–	–	–	–	–	–	–	–
085	–	–	–	–	–	–	–	–	–	–	–
090	–	–	–	–	–	–	–	–	–	–	–
095	–	–	–	–	–	–	–	–	–	–	–

General Data Coils

Refrigerant Coil Circuits (1/2" Interwined Refrigerant Coil Circuiting)

Dimensions

Model Size	Coil Face Area		Actual Fin Height		Finned Length		No. of Dist	Piping Ø		
	Ft ²	M ²	in	mm	in	mm		Liquid		Suction
								1/4"	3/16"	O.D.
003	2.5	0.23	21	533	17	432	1/1	28.6	22.2	41
004	4.3	0.40	21	533	29	737	1/1	28.6	22.2	41
006	6.1	0.56	21	533	41	1041	1/1	28.6	22.2	41
008	7.9	0.73	21	533	53	1346	1/1	28.6	22.2	41
010	9.7	0.90	34	864	41	1041	1/1	35	28.6	41
012	12.5	1.16	34	864	53	1346	1/1	35	28.6	41
014	15.3	1.42	34	864	65	1651	1/1	35	28.6	41
016	17.1	1.59	46	1168	53	1346	1/1/1/1	28.6	22.2	41
020	21.0	1.95	46	1168	65	1651	1/1/1/1	28.6	22.2	41
025	26.0	2.42	58	1473	65	1651	1/1/1/1	35	28.6	41
030	31.5	2.93	70	1778	65	1651	1/1/1/1	35	28.6	41
035	37.3	3.47	70	1778	77	1956	1/1/1/1	35	28.6	41
040	43.2	4.02	70	1778	89	2261	1/1/1/1	35	28.6	41
045	49.0	4.56	70	1778	101	2565	1/1/1/1	35	28.6	41
050	54.8	5.10	70	1778	113	2870	1/1/1/1	35	28.6	41
060	64.0	5.93	40	1016	113	2870	1/1/1/1	28.6	22.2	41
			41	1041	113	2870	1/1/1/1			
065	70.8	6.56	40	1016	125	3175	1/1/1/1	28.6	22.2	41
			41	1041	125	3175	1/1/1/1			
070	77.6	7.19	40	1016	137	3480	1/1/1/1	28.6	22.2	41
			41	1041	137	3480	1/1/1/1			
080	84.4	7.82	40	1016	149	3785	1/1/1/1	28.6	22.2	41
			41	1041	149	3785	1/1/1/1			
085	91.1	8.45	40	1016	161	4089	1/1/1/1	28.6	22.2	41
			41	1041	161	4089	1/1/1/1			
090	97.9	9.08	40	1016	173	4394	1/1/1/1	28.6	22.2	41
			41	1041	173	4394	1/1/1/1			
095	104.5	9.71	40	1016	185	4699	1/1/1/1	28.6	22.2	41
			41	1041	185	4699	1/1/1/1			

General Data Filters

General

Quantum™ Climate Changer™ air handling unit offers wide range of filters to meet air filtration requirement in various types of commercial and industrial air conditioning applications. Filter type offered are:

- (a) Washable and throwaway type flat filters
- (b) Bag and cartridge type filters
- (c) Final or Hepa filters
- (d) Carbon or gas filters, etc.

Flat Filter and High Capacity Filter

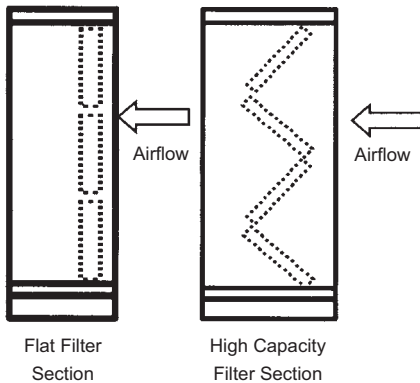

a) Washable Filter

The filter is for use in room air conditioning units, hot air generators and air conditioning installation. The filter media consist of selected synthetic fibers. An exclusive bonding technology provides the media with high numbers of fibers per square meter for a given weight. Its characteristics are relatively low resistance to air flow and a high dust holding capacity. The media can be cleaned:

- in warm water (30° - 40°C) with addition of a household detergent if necessary. Drying should be done on a flat surface. Do not rub or wiring.
- by blowing with compressed air in the opposite direction of filter airflow.

Washable Filter – Product Information	
Normal Sizes (inch)	: 12x24 20x24, 24x24
Filter Depth (mm)	: 50
Average Arrestance	: 80 – 85%

b) Throwaway Filter

Unique “pleat” design assures total usage of the filter media, maximum dust holding capacity and extended service life. Its greater dust holding capacity not only extends replacement intervals, but considerably lengthens the service life of any other secondary filters in the systems.

The media used is a lofted, high performance, nonwoven, reinforced cotton and synthetic fabric. Filter media shall be of high density glass mirco fibers laminated to all glass woven mesh backing. The filter media shall have an average arrestance of 90 – 92%. The filter is categorized as a 30% efficiency filter.

Throwaway Filter – Product Information	
Normal Sizes (inch)	: 12x24 20x24, 24x24
Filter Depth (mm)	: 50
Average Arrestance	: 90 – 92%
Average Efficiency	: 25 – 30%

General Data Filters

High Efficiency Filter Section

a. Bag Filter

The filter is an extended surface non-supported pocket filter which offers high efficiency, low resistance, compactness and unusual dust-holding capacity. When placed in ventilating system, the pockets of the filtering media inflate for maximum efficiency and dust holding capacity.

Filter efficiency is determined by the size and quality of fibers per square inch. In each efficiency category the media is manufactured to rigid specifications that assure an extremely large amount of dirt-catching surface area to catch microscopic contaminants.

The exclusive pocket design allows every channel to fully inflate while maintaining the amount of space between pockets. Clean air can freely exit from front to back. Some manufacturer's design permit adjacent pockets to touch when inflated which significantly reduces dust holding capacity.

Each filter pocket is attached to a support frame that fits into a U-channel header. Each pocket support frame is then mechanically fastened to the adjacent frame forming a rigid construction that does not rack during handling and installation. The positive locking arrangement forms an air tight seal and also virtually eliminates the possibility of pocket separation from the header as resistance increase.

Bag Filter – Product Information	
Normal Sizes (inch) :	12x24 20x24, 24x24
Filter Depth (mm) :	381
Average Efficiency :	60 – 65% 80 – 85% 90 – 95%

b. Cartridge Filter

The filters are ideally suited to variable volume systems. Being totally rigid, Performance is not affected by changes in air velocity or fan shutdown, and their configuration is not altered by accumulation of dirt. High loft glass fiber media is laminated to which provides positive support, optimizes dust holding capacity, and precludes fiber emission, as compared to flat glass media.

All double wall fiber board contour stabilizers, diagonal support provide rigidity, durability, consistent integrity and performance reliability throughout the filter's life.

The lofted media and exclusive radial pleats provide a high dust holding capacity, extending the life of the filter. The filter will operate at air volumes considerably below rates velocity and capacity. Initial resistance is reduced, performance is improved and service life is extended.

Cartridge Filter – Product Information	
Normal Sizes (inch) :	12x24 20x24, 24x24
Filter Depth (mm) :	100
Average Efficiency :	60 – 65% 80 – 85% 90 – 95%



General Data Filters

Filter Quantity and Sizes (Nominal)

a. Flat, Bag and Cartridge Filters

Model Size	Filter Face Area Sq.Ft.	Filter Sizes (inch)		
		12x24	20x24	24x24
003	3.3	–	1	–
004	3.3	–	1	–
006	6.7	–	2	–
008	6.7	–	2	–
010	10.7	2	2	–
012	10.7	2	2	–
014	16.0	3	3	–
016	20.0	2	–	4
020	24.0	–	–	6
025	30.0	3	–	6
030	36.0	–	–	9
035	42.0	3	–	9
040	48.0	–	–	12
045	54.0	3	–	12
050	60.0	–	–	15
060	70.0	5	–	15
065	76.0	8	–	15
070	84.0	6	–	18
080	90.0	9	–	18
085	98.0	7	–	21
090	104.0	10	–	21
095	112.0	8	–	24







b. High Capacity Filters

Model Size	Filter Face Area	Filter Sizes (inch)
		20x24
003	8	2
004	8	2
006	16	4
008	16	4
010	32	8
012	32	8
014	48	12
016	40	10
020	60	15
025	84	21
030	96	24
035	96	24
040	128	32
045	128	32
050	160	40
060	180	45
065	180	45
070	216	54
080	216	54
085	252	63
090	252	63
095	308	63

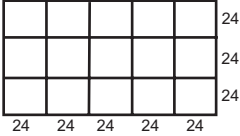
General Data Filters

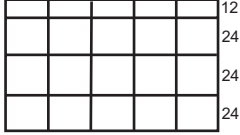
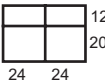
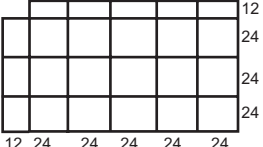
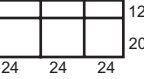
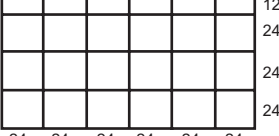

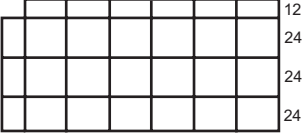

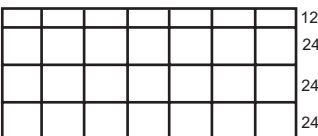
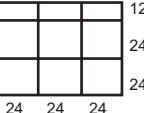
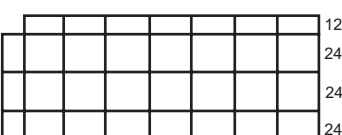
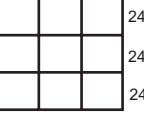
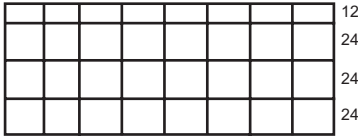
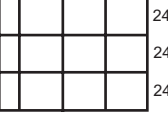
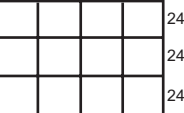
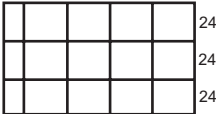
Filter Dimension (Nominal) and Arrangement



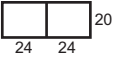
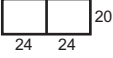
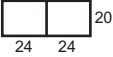
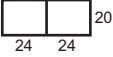
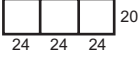
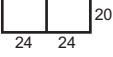
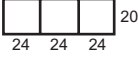

Flat Filter, Bag Filter & Cartridge Filter

Model	Arrangement	(Nominal Sizes In Inches)	Model	Arrangement	(Nominal Sizes In Inches)	
003 004		24 20	050		24 24 24	
006 008		24 24 20		060		12 24 24 24
010 012		12 24 20			065	
014		24 24 24 12	070			
016		12 24 24 24		080		
020		24 24 24 24			085	
025		12 24 24 24	090			
030		24 24 24 24		095		
035		12 24 24 24 24				
040		24 24 24 24 24				
045		12 24 24 24 24 24				

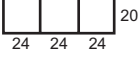
General Data Filters

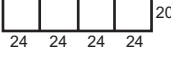
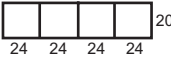
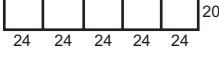
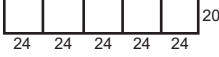
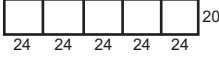
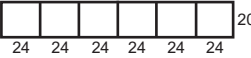
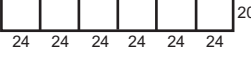
Filter Dimension (Nominal) and Arrangement High Capacity Filter

FILTER PLAN		
Model	Dimension	Filter Arrangement
003	2 ROWS – 24" X 20"	
004	2 ROWS – 24" X 20"	
006	2 ROWS – 48" X 20"	
008	2 ROWS – 48" X 20"	
010	4 ROWS – 48" X 20"	
012	4 ROWS – 48" X 20"	
014	4 ROWS – 72" X 20"	
016	5 ROWS – 48" X 20"	
020	5 ROWS – 72" X 20"	
025	7 ROWS – 72" X 20"	
030	8 ROWS – 72" X 20"	

FILTER PLAN		
Model	Dimension	Filter Arrangement
035	8 ROWS – 72" X 20"	
040	8 ROWS – 96" X 20"	
045	8 ROWS – 96" X 20"	
050	8 ROWS – 120" X 20"	
060	9 ROWS – 120" X 20"	
065	9 ROWS – 120" X 20"	
070	9 ROWS – 144" X 20"	
080	9 ROWS – 144" X 20"	
085	9 ROWS – 168" X 20"	
090	9 ROWS – 168" X 20"	
095	9 ROWS – 168" X 20"	

General Data Filters

Final Filter (HEPA)

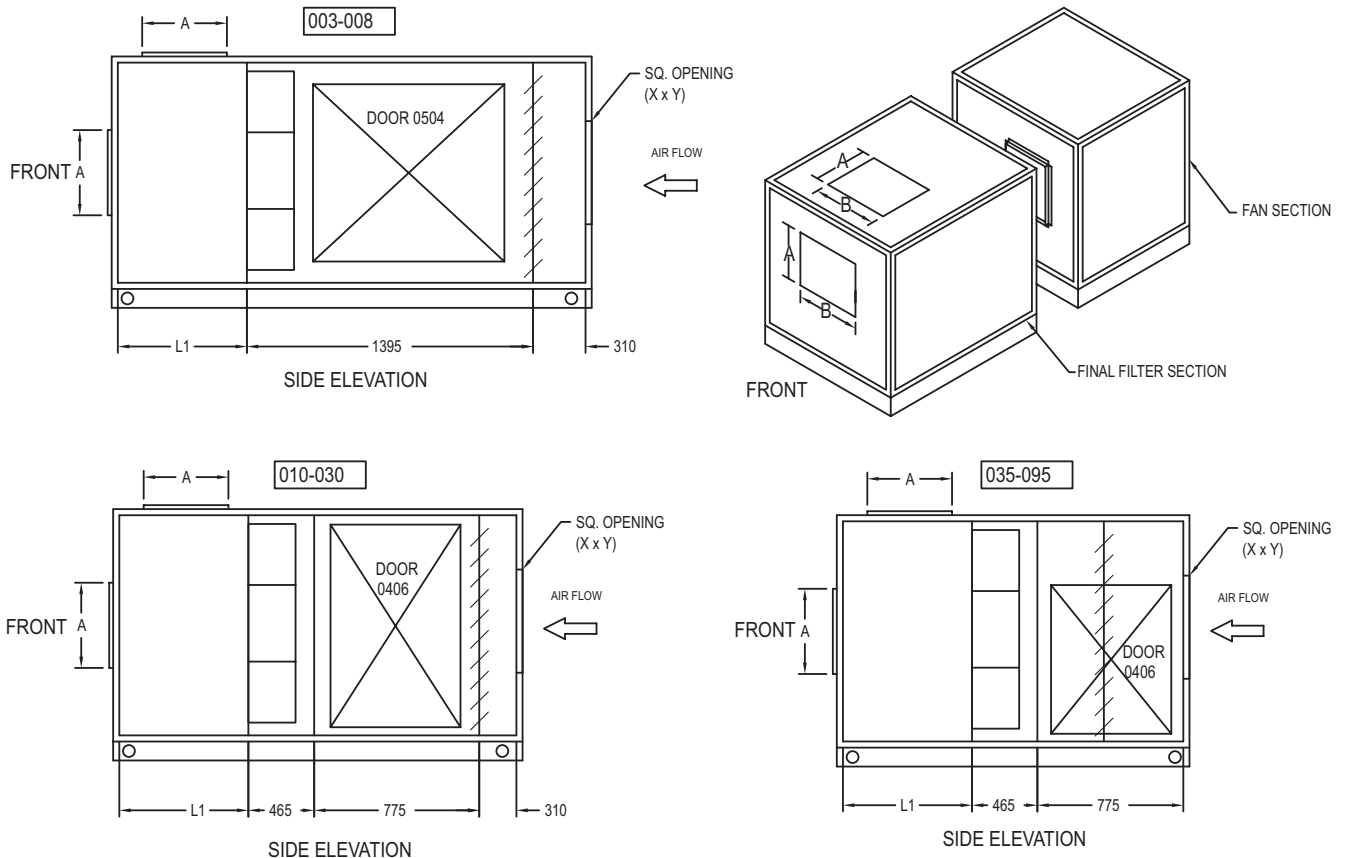



Final Filter Casing Dimension

CLCP - AHU	Final Filter (HEPA) Casing Size	25mm Casing Dimension			50mm Casing Dimension			Outlet Opening	Discharge Plenum Section
		W	H	L	W	H	L		
Std. Model	(X 155 parametric)							B x A	L1
003 (0404)	0505	853	973	2248	903	1023	2298	465 x 310	465
004 (0604)	0605	1008	973	2248	1058	1023	2298	465 x 310	465
006 (0804)	0905	1473	973	2248	1523	1023	2298	465 x 310	465
008 (1004)	1005	1628	973	2248	1678	1023	2298	620 x 310	465
010 (0806)	0907	1473	1283	2093	1523	1333	2143	620 x 310	465
012 (1006)	1007	1628	1283	2093	1678	1333	2143	620 x 310	465
014 (1206)	1307	2093	1283	2093	2143	1333	2143	775 x 310	465
016 (1008)	1109	1783	1593	2248	1833	1643	2298	775 x 465	620
020 (1208)	1309	2093	1593	2248	2143	1643	2298	775 x 465	620
025 (1210)	1311	2093	1903	2248	2143	1953	2298	930 x 465	620
030 (1212)	1313	2093	2213	2403	2143	2263	2453	930 x 620	775
035 (1412)	1614	2558	2368	2248	2608	2418	2298	930 x 775	930
040 (1612)	1813	2868	2213	2248	2918	2263	2298	1085 x 775	930
045 (1812)	1914	3023	2368	2248	3073	2418	2298	1240 x 775	930
050 (2012)	2213	3488	2213	2248	3538	2263	2298	1240 x 775	930
060 (2014)	2215				3538	2573	2298	1705 x 775	930
065 (2214)	2215				3538	2573	2298	1860 x 775	930
070 (2414)	2715				4313	2573	2298	2015 x 775	930
080 (2614)	2715				4313	2573	2298	2170 x 775	930
085 (2814)	3215				5088	2573	2298	2170 x 775	930
090 (3014)	3215				5088	2573	2453	2325 x 930	1085
095 (3214)	3215				5088	2573	2453	2480 x 930	1085

General Data Filters

Filter Dimension (Nominal) and Arrangement

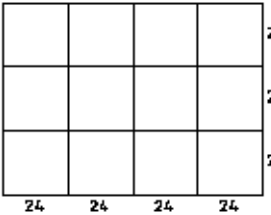
Final Filter

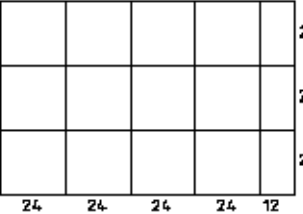
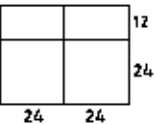
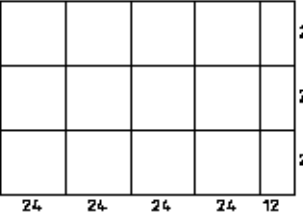
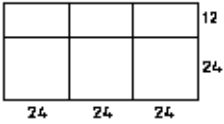
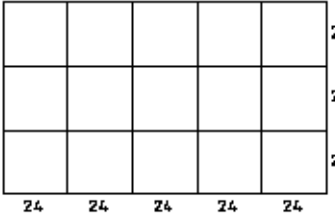
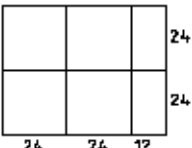
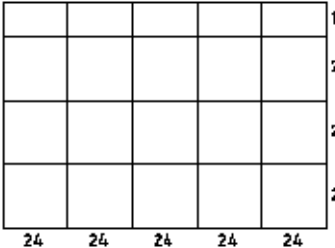
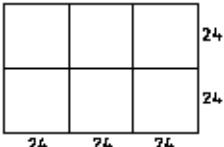
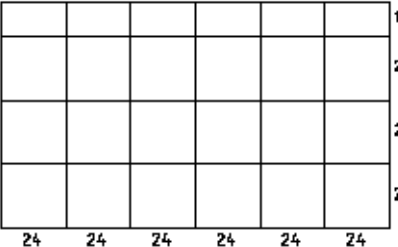
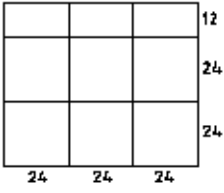
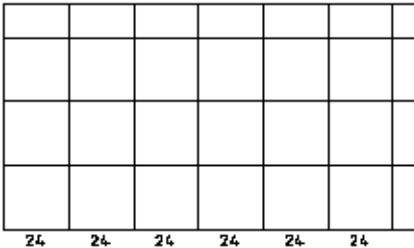
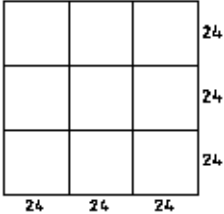
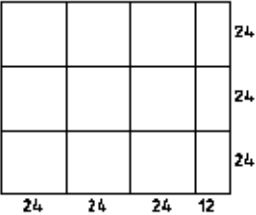
MODEL	ARRANGEMENT	(NOMINAL SIZES N mm)	MODEL	ARRANGEMENT	(NOMINAL SIZES IH mm)	
003(0404) = 0505 004(0604) = 0605		24	040(1612) = 1713		24 24 24	
008(0804) = 0905 008(1004) = 1005		24 24			24 24 24 24 24 24 24	
010(0808) = 0907 012(1008) = 1007		12 24		045(1812) = 2013		24 24 24 24 24 24 24 12
014(1208) = 1307		12 24 24	050(2012) = 2213			24 24 24 24 24 24 24 24
016(1008) = 1109		24 24 12		080(2014) = 2215 085(2214) = 2215		12 24 24 24 24 24 24 24 24
020(1208) = 1309		24 24 24			070(2414) = 2615 080(2614) = 2615	
025(1210) = 1311		12 24 24	085(2814) = 3015 090(3014) = 3015 095(3214) = 3215			12 24 24 24 24 24 24 24 24 24 24
030(1212) = 1313		24 24 24		035(1412) = 1513		

Dimensional Data HDT (Single Motor) – Unit Dimensions

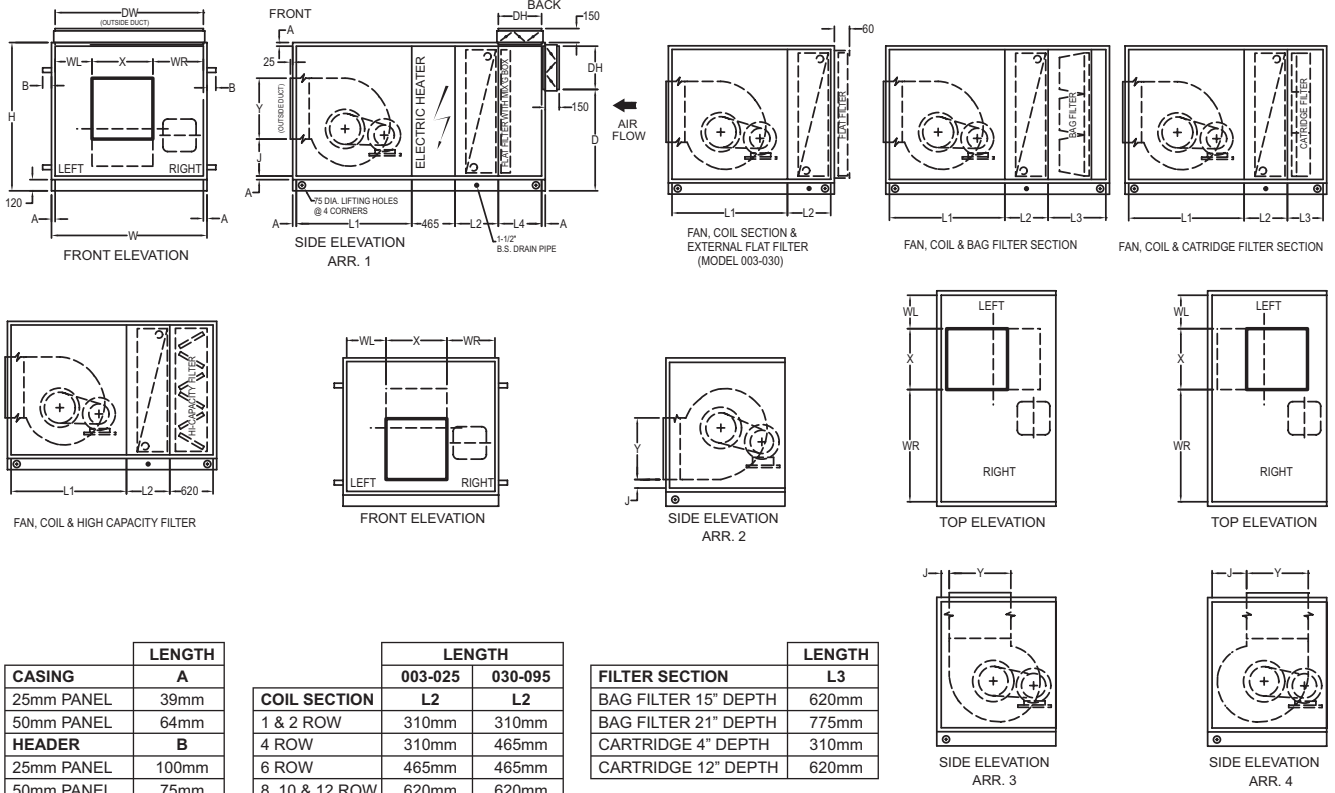

CASING	LENGTH A
25mm PANEL	39mm
50mm PANEL	64mm
HEADER B	
25mm PANEL	100mm
50mm PANEL	75mm

COIL SECTION	LENGTH	
	003-025 L2	030-095 L2
1 & 2 ROW	310mm	310mm
4 ROW	310mm	465mm
6 ROW	465mm	465mm
8, 10 & 12 ROW	620mm	620mm

FILTER SECTION	LENGTH L3
BAG FILTER 15" DEPTH	620mm
BAG FILTER 21" DEPTH	775mm
CARTRIDGE 4" DEPTH	310mm
CARTRIDGE 12" DEPTH	620mm

MODEL	FAN	MOTOR KW	FAN ARR				FAN SECTION		MOTOR ACCESS				FLAT FILTER W/ MIX. SECT.	25mm CASING			50mm CASING			DAMPER				
			J				L1		RH	LH	X	Y		L4	H	W	D	H	W	D	DW	DH		
			ARR 1	ARR 2	ARR 3	ARR 4	ARR 1,2	ARR 3,4					WL										WR	WL
003(0404)	F/BDB 200	0.18 - 3	221	115	100	185	775	775	170	170	170	170	274	274	310	818	698	469	868	748	494	620	310	
004(0604)	F/BDB 225	0.37 - 3	236	115	99	217	775	775	155	468	468	155	307	307	310	818	1008	469	868	1058	494	930	310	
006(0804)	F/BDB 250	0.55 - 7.5	246	116	97	227	775	930	199	702	702	199	340	340	310	818	1318	469	868	1368	494	1240	310	
008(1004)	F/BDB 280	0.75 - 7.5	194	46	98	247	775	930	336	837	837	336	378	378	310	818	1628	469	868	1678	494	1550	310	
010(0806)	F/BDB 315	1.1 - 7.5	283	115	96	264	930	930	161	657	657	161	422	422	310	1128	1318	779	1178	1368	804	1240	310	
		11					1085	1240	409	409	409	409												
012(1006)	F/BDB 400	1.1 - 7.5	337	116	97	318	930	1085	209	817	817	209	524	524	310	1128	1628	779	1178	1678	804	1550	310	
		11 - 15					1085	1240																
014(1206)	F/BDB 400	1.5 - 7.5	337	116	97	318	930	1085	349	987	987	349	524	524	310	1128	1938	779	1178	1988	804	1860	310	
		11 - 15					1085	1240																
016(1008)	F/BDB 450	1.5 - 7.5	365	117	99	345	930	1240	227	738	738	227	586	586	310	1438	1628	1089	1488	1678	1114	1550	310	
		11 - 18.5					1395	1550																
020(1208)	F/BDB 500	2.2 - 7.5	387	117	100	368	930	1240	266	938	938	266	656	656	310	1438	1938	1089	1488	1988	1114	1860	310	
		11 - 18.5					1085	1395																
025(1210)	F/BDB 560	2.2 - 7.5	446	145	100	401	1240	1550	276	851	851	276	732	732	465	1748	1938	1244	1798	1988	1269	1860	465	
		11 - 15					1550	1705																
030(1212)	F/BDB 560	2.2 - 7.5	446	145	100	401	1085	1395																
		11 - 15					1240	1550	276	851	851	276	732	732	465	2058	1938	1554	2108	1988	1579	1860	465	
		18.5 - 30					1550	1705																
035(1412)	F/BDB 630	4 - 22	540	196	100	443	1240	1395	294	1058	1058	294	818	818	465	2058	2248	1554	2108	2298	1579	2170	465	
		30 - 45					1550	1705																
040(1612)	F/BDB 710	4 - 22	589	198	100	489	1395	1550	406	1158	1158	406	916	916	620	2058	2558	1399	2108	2608	1424	2480	620	
		30 - 45					1550	1705																
045(1812)	F/BDB 710	4 - 22	589	198	100	489	1395	1550	561	1313	1313	561	916	916	620	2058	2868	1399	2108	2918	1424	2790	620	
		30 - 45					1550	1705																
050(2012)	F/BDB 800	5.5 - 22	648	201	100	547	1550	1705	602	1474	1474	602	1024	1024	620	2058	3178	1399	2108	3228	1424	2790	620	
		30 - 45					1705	1860																
060(2014)	F/BDB 800	7.5 - 22	648	201	100	547	1550	1705	602	1474	1474	602	1024	1024	775	-	-	-	2418	3228	1579	2790	775	
		30 - 45					1705	1860																
065(2214)	F/BDB 900	7.5 - 22	702	198	100	604	1550	1860	671	1591	1591	671	1148	1148	775	-	-	-	2418	3538	1579	2790	775	
		30 - 75					1860	2015																
070(2414)	F/BDB 900	7.5 - 22	702	198	100	604	1550	1860	826	1746	1746	826	1148	1148	930	-	-	-	2418	3848	1424	2790	930	
		30 - 75					1860	2015																
080(2614)	F/BDB 1000	7.5 - 75	732	207	102	627	1860	2015	831	1914	1914	831	1284	1284	930	-	-	-	2418	4158	1424	2790	930	
085(2814)	F/BDB 1000	7.5 - 75	732	207	102	627	1860	2015	986	2069	2069	986	1284	1284	1085	-	-	-	2418	4468	1269	2790	1085	
090(3014)	F/BDB 1000	11 - 75	732	207	102	627	1860	2015	1141	2224	2224	1141	1284	1284	1085	-	-	-	2418	4778	1269	2790	1085	
095(3214)	F/BDB 1000	11 - 75	732	207	102	627	1860	2015	1296	2379	2379	1296	1284	1284	1085	-	-	-	2418	5088	1269	2790	1085	

Dimensional Data HDT (Dual Motor) – Unit Dimensions

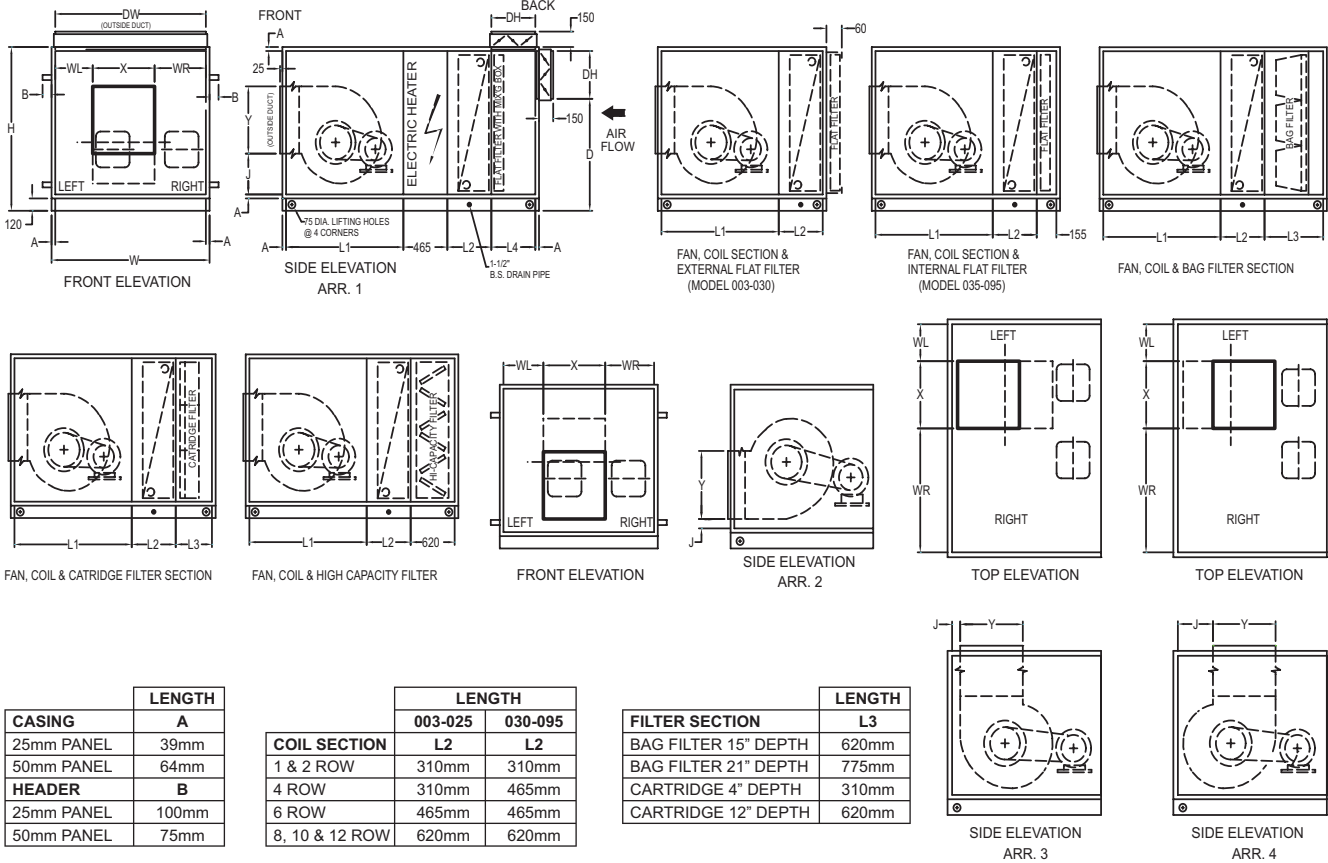

CASING	LENGTH	
	A	
25mm PANEL	39mm	
50mm PANEL	64mm	
HEADER	B	
	25mm PANEL 100mm	
50mm PANEL 75mm		

COIL SECTION	LENGTH	
	003-025	030-095
1 & 2 ROW	L2 310mm	L2 310mm
4 ROW	L2 310mm	L2 465mm
6 ROW	L2 465mm	L2 465mm
8, 10 & 12 ROW	L2 620mm	L2 620mm

FILTER SECTION	LENGTH
	L3
BAG FILTER 15" DEPTH	620mm
BAG FILTER 21" DEPTH	775mm
CARTRIDGE 4" DEPTH	310mm
CARTRIDGE 12" DEPTH	620mm

MODEL	FAN	MOTOR KW	FAN ARR				FAN SECTION		MOTOR ACCESS				X	Y	FLAT FILTER W/ MIX. SEC.	25mm CASING			50mm CASING			DAMPER		
			J				L1		RH		LH					L4	H	W	D	H	W	D	DW	DH
			ARR 1	ARR 2	ARR 3	ARR 4	ARR 1,2	ARR 3,4	WL	WR	WL	WR												
003(0404)	F/BDB 200	0.18 ~ 3	230	120	100	200	1240	1240	175	175	175	175	270	270	310	818	698	469	868	748	494	620	310	
004(0604)	F/BDB 225	0.37 ~ 3	254	111	99	253	930	930	167	480	480	167	283	307	310	818	1008	469	868	1058	494	930	310	
006(0804)	F/BDB 250	0.55 ~ 7.5	227	113	97	227	930	930	199	702	702	199	340	340	310	818	1318	469	868	1368	494	1240	310	
008(1004)	F/BDB 280	0.75 ~ 7.5	183	34	98	246	930	1085	336	837	837	336	378	378	310	818	1628	469	868	1678	494	1550	310	
010(0806)	F/BDB 315	1.1 ~ 7.5	280	112	96	264	1085	1085	161	657	657	161	422	422	310	1128	1318	624	1178	1368	649	1240	310	
012(1006)	F/BDB 400	1.1 ~ 15	347	127	97	318	1240	1395	209	817	817	209	524	524	310	1128	1628	624	1178	1678	649	1550	310	
014(1206)	F/BDB 400	1.5 ~ 15	347	127	97	318	1240	1395	349	987	987	349	524	524	310	1128	1938	624	1178	1678	649	1860	310	
016(1008)	F/BDB 450	1.5 ~ 7.5 11 ~ 18.5	367	119	98	346	1240	1395	227	738	738	227	586	586	310	1438	1628	934	1488	1988	959	1550	310	
020(1208)	F/BDB 500	2.2 ~ 18.5	389	119	98	368	1395	1550	266	938	938	266	656	656	310	1438	1938	934	1488	1988	959	1860	310	
025(1210)	F/BDB 560	2.2 ~ 15 18.5 ~ 22	490	189	100	401	1550	1705	276	851	851	276	732	732	465	1748	1938	1244	1798	1988	1269	1860	465	
030(1212)	F/BDB 560	3 ~ 15 18.5 ~ 30	490	189	100	401	1550	1705	276	851	851	276	732	732	465	2058	1938	1399	2108	1988	1424	1860	465	
035(1412)	F/BDB 630	3.7 ~ 22 30 ~ 45	542	198	100	443	1550	1860	294	1058	1058	294	181	181	465	2058	2248	1399	2108	2298	1424	2170	465	
040(1612)	F/BDB 710	3.7 ~ 22 30 ~ 45	590	200	100	491	1705	2015	406	1158	1158	406	916	916	620	2058	2558	1399	2108	2608	1424	2480	620	
045(1812)	F/BDB 710	3.7 ~ 22 30 ~ 45	590	200	100	491	1705	2015	561	1313	1313	561	916	916	620	2058	2868	1399	2108	2918	1424	2790	620	
050(2012)	F/BDB 800	5.5 ~ 22 30 ~ 45	663	216	100	547	2015	2325	602	1474	1474	602	1024	1024	620	2058	3178	1399	2108	3228	1424	2790	620	
060(2014)	F/BDB 800	7.5 ~ 22 30 ~ 45	663	216	100	547	2015	2325	602	1474	1474	602	1024	1024	775	~	~	~	2418	3228	1424	2790	775	
065(2214)	F/BDB 900	7.5 ~ 22 30 ~ 75	714	210	100	604	2015	2325	671	1591	1591	671	1148	1148	775	~	~	~	2418	3538	1424	2790	775	
070(2414)	F/BDB 900	7.5 ~ 22 30 ~ 75	714	210	100	604	2170	2480	826	1746	1746	826	1148	1148	930	~	~	~	2418	3848	1269	2790	930	
080(2614)	F/BDB 1000	7.5 ~ 22 30 ~ 75	734	212	102	627	2170	2480	831	1914	1914	831	1284	1284	930	~	~	~	2418	4158	1269	2790	930	
085(2814)	F/BDB 1000	7.5 ~ 22 30 ~ 75	734	212	102	627	2170	2480	986	2069	2069	986	1284	1284	1085	~	~	~	2418	4468	1114	2790	1085	
090(3014)	F/BDB 1000	11 ~ 22 30 ~ 75	734	212	102	627	2170	2480	1141	2224	2224	1141	1284	1284	1085	~	~	~	2418	4778	1114	2790	1085	
095(3214)	F/BDB 1000	11 ~ 22 30 ~ 75	734	212	102	627	2170	2480	1296	2379	2379	1296	1284	1284	1085	~	~	~	2418	5088	1114	2790	1085	



Dimensional Data HDT – Unit Weight

HDT Unit Weight (kg) – Fan and Coil Sections (without motor weight)

50mm Casing

Model Size	Fan Section Weight		Coil Section Weight						
	Fan Arrangement		Coil Row						
	Front-Top and Front-Bottom	Top-Front and Top-Back	1	2	4	6	8	10	12
003	68	68	52	55	69	83	101	112	123
004	82	82	67	71	91	112	136	153	171
006	111	111	82	87	116	140	171	193	217
008	128	128	97	103	134	170	208	236	263
010	140	140	109	117	152	192	235	269	304
012	178	190	131	141	183	234	288	332	377
014	196	209	150	162	212	273	337	390	444
016	238	251	165	178	234	300	371	429	488
020	282	297	187	203	268	348	431	502	573
025	364	379	217	237	315	410	510	596	684
030	406	407	268	292	384	500	622	729	840
035	466	483	302	330	436	571	712	838	965
040	567	585	335	368	487	644	803	949	1093
045	592	611	376	413	549	726	907	1074	1238
050	740	782	409	451	601	798	999	1181	1369
060	765	809	465	515	694	926	1163	1379	1603
065	930	923	539	594	790	1051	1317	1560	1808
070	930	954	577	637	852	1134	1424	1689	1958
080	1067	1092	620	685	912	1219	1530	1817	2107
085	1099	1125	676	747	994	1328	1668	1984	2300
090	1137	1164	716	791	1056	1414	1775	2111	2447
095	1168	1196	754	835	1116	1497	1882	2239	2595

25mm Casing

Model Size	Fan Section Weight		Coil Section Weight						
	Fan Arrangement		Coil Row						
	Front-Top and Front-Bottom	Top-Front and Top-Back	1	2	4	6	8	10	12
003	51	51	50	52	66	80	97	108	119
004	62	62	62	65	83	104	126	142	160
006	81	81	75	80	102	130	159	181	204
008	96	96	90	96	124	159	194	222	249
010	105	105	102	110	141	181	221	255	290
012	135	144	123	133	171	222	272	316	361
014	149	159	141	153	199	260	319	372	426
016	179	188	156	169	221	287	353	412	471
020	212	222	177	193	254	333	411	482	554
025	277	288	206	227	299	394	489	575	663
030	319	319	256	281	367	483	599	707	817
035	354	360	289	318	418	553	688	814	940
040	439	452	321	355	468	624	777	922	1067
045	458	472	361	399	528	705	880	1046	1210
050	582	613	394	436	579	776	970	1151	1339

1. Coil weight is the operating weight.

Motor Weight (kg)

Motor kW	0.18	0.37	0.55	0.75	1.1	1.5	2.2	3.0	3.7	4.0	5.5	7.5	11	15
Weight, kg	7.8	12	15	20	22	30	42	65	76	118	139	189	203	290

Motor kW	18.5	22	30	37	45	55	75
Weight, kg	320	348	355	500	520	550	580



Dimensional Data HDT – Unit Weight

HDT Unit Weight (kg) – Fan + Coil + Filter Sections (without motor weight)

50mm Casing

Model Size	Fan Section Weight		Coil Section Weight							Filter Section Length, L3			
	Fan Arrangement		Coil Row							2" Flat Filter	2" Hi-Capacity Filter	2" Flat Filter + 15" Bag Filter	2" Flat Filter + 4" Cartridge Filter
	Front-Top and Front-Bottom	Top-Front and Top-Back	1	2	4	6	8	10	12				
003	68	68	52	55	69	83	101	112	123	21	47	36	41
004	82	82	67	71	91	112	136	153	171	25	57	38	48
006	111	111	82	87	116	140	171	193	217	32	67	44	58
008	128	128	97	103	134	170	208	236	263	38	81	50	67
010	140	140	109	117	152	192	235	269	304	35	84	54	71
012	178	190	131	141	183	234	288	332	377	41	102	62	81
014	196	209	150	162	212	273	337	390	444	48	111	70	94
016	238	251	165	178	234	300	371	429	488	44	117	67	100
020	282	297	187	203	268	348	431	502	573	50	128	74	112
025	364	379	217	237	315	410	510	596	684	54	149	83	129
030	406	407	268	292	384	500	622	729	840	56	165	96	142
035	466	483	302	330	436	571	712	838	965	68	193	106	161
040	567	585	335	368	487	644	803	949	1093	75	205	116	175
045	592	611	376	413	549	726	907	1074	1238	82	232	125	194
050	740	782	409	451	601	798	999	1181	1369	75	230	142	219
060	765	809	465	515	694	926	1163	1379	1603	82	251	157	249
065	930	923	539	594	790	1051	1317	1560	1808	88	279	169	269
070	930	954	577	637	852	1134	1424	1689	1958	95	290	180	288
080	1067	1092	620	685	912	1219	1530	1817	2107	101	319	187	315
085	1099	1125	676	747	994	1328	1668	1984	2300	108	330	198	328
090	1137	1164	716	791	1056	1414	1775	2111	2447	114	359	209	349
095	1168	1196	754	835	1116	1497	1882	2239	2595	119	365	220	362

25mm Casing

Model Size	Fan Section Weight		Coil Section Weight							Filter Section Length, L3			
	Fan Arrangement		Coil Row							2" Flat Filter	2" Hi-Capacity Filter	2" Flat Filter + 15" Bag Filter	2" Flat Filter + 4" Cartridge Filter
	Front-Top and Front-Bottom	Top-Front and Top-Back	1	2	4	6	8	10	12				
003	51	51	50	52	66	80	97	108	119	19	42	31	36
004	62	62	62	65	83	104	126	142	160	23	48	29	39
006	81	81	75	80	102	130	159	181	204	31	58	34	48
008	96	96	90	96	124	159	194	222	249	37	70	39	56
010	105	105	102	110	141	181	221	255	290	33	72	43	59
012	135	144	123	133	171	222	272	316	361	39	88	49	68
014	149	159	141	153	199	260	319	372	426	46	97	55	80
016	179	188	156	169	221	287	353	412	471	42	103	52	85
020	212	222	177	193	254	333	411	482	554	48	112	58	96
025	277	288	206	227	299	394	489	575	663	51	131	66	112
030	319	319	256	281	367	483	599	707	817	53	146	77	123
035	354	360	289	318	418	553	688	814	940	65	172	85	140
040	439	452	321	355	468	624	777	922	1067	72	183	94	153
045	458	472	361	399	528	705	880	1046	1210	80	209	102	171
050	582	613	394	436	579	776	970	1151	1339	73	206	118	195

1. Coil weight is the operating weight.
2. Filter section weight includes filter media

Motor Weight (kg)

Motor kW	0.18	0.37	0.55	0.75	1.1	1.5	2.2	3.0	3.7	4.0	5.5	7.5	11	15
Weight, kg	7.8	12	15	20	22	30	42	65	76	118	139	189	203	290

Motor kW	18.5	22	30	37	45	55	75
Weight, kg	320	348	355	500	520	550	580



Dimensional Data HDT – Unit Weight

HDT Unit Weight (kg) – Fan + Coil + Filter and Mixing Sections (without motor weight)

50mm Casing

Model Size	Fan Section Weight (kg)		Coil Section Weight (kg)							Filter Section Weight (kg)				Mixing Box/Rear or Top Inlet Section Weight
	Fan Arrangement		Coil Row							2"Flat Filter	2"Hi-Capacity Filter	2"Flat Filter + 15"Bag Filter	2"Flat Filter + 4"Cartridge Filter	
	Front-Top & Front-Bottom	Top-Front & Top-Back	1	2	4	6	8	10	12					
003	51	51	50	52	66	80	97	108	119	0	47	36	29	38
004	62	62	62	65	83	104	126	143	160	0	57	38	34	45
006	81	81	75	80	102	130	159	181	205	0	68	44	43	54
008	96	96	90	96	124	159	194	222	249	0	81	50	50	64
010	105	105	102	110	141	181	221	255	290	0	84	55	54	66
012	135	144	123	133	171	222	273	316	361	0	101	62	63	76
014	149	159	141	153	199	260	320	372	426	0	111	70	74	81
016	179	188	156	169	221	287	353	412	471	0	117	71	80	104
020	212	222	177	193	254	333	411	482	554	0	128	74	90	111
025	277	288	206	227	299	394	483	575	663	0	149	83	105	115
030	319	319	256	281	367	483	600	707	817	0	165	96	116	134
035	354	360	289	318	418	553	688	814	940	0	193	106	134	148
040	439	452	321	355	468	624	777	922	1067	0	205	115	146	161
045	458	472	361	399	528	705	880	1046	1210	0	232	142	163	211
050	582	613	394	436	579	776	970	1151	1339	0	230	157	187	215
060	765	809	465	515	694	926	1163	1379	1603	0	251	157	214	241
065	900	923	539	594	790	1051	1317	1560	1808	0	279	169	233	279
070	930	954	577	637	852	1134	1424	1689	1958	0	290	180	251	324
080	1068	1092	619	685	912	1219	1530	1817	2107	0	319	187	276	332
085	1099	1120	676	747	994	1328	1668	1984	2300	0	330	198	287	379
090	1137	1164	715	791	1056	1414	1775	2111	2447	0	359	209	307	388
095	1168	1196	754	834	1116	1497	1882	2239	2595	0	365	220	317	397

25mm Casing

Model Size	Fan Section Weight (kg)		Coil Section Weight (kg)							Filter Section Weight (kg)				Mixing Box/Rear or Top Inlet Section Weight
	Fan Arrangement		Coil Row							2"Flat Filter	2"Hi-Capacity Filter	2"Flat Filter + 15"Bag Filter	2"Flat Filter + 4"Cartridge Filter	
	Front-Top & Front-Bottom	Top-Front & Top-Back	1	2	4	6	8	10	12					
003	51	51	50	52	66	80	97	108	119	0	42	31	26	35
004	62	62	62	65	83	104	126	143	160	0	48	31	31	42
006	81	81	75	80	102	130	159	181	205	0	58	34	39	51
008	96	96	90	96	124	159	194	222	249	0	70	39	46	60
010	105	105	102	110	141	181	221	255	290	0	72	43	49	58
012	135	144	123	133	171	222	273	316	361	0	88	49	57	68
014	149	159	141	153	199	260	320	372	426	0	97	55	68	71
016	179	188	156	169	221	287	353	412	471	0	103	55	74	89
020	212	222	177	193	254	333	411	482	554	0	112	58	83	95
025	277	288	206	227	299	394	483	575	663	0	131	66	98	98
030	319	319	256	281	367	483	600	707	817	0	146	77	108	114
035	354	360	289	318	418	553	688	814	940	0	172	85	125	127
040	439	452	321	355	468	624	777	922	1067	0	183	94	137	140
045	458	472	361	399	528	705	880	1046	1210	0	209	102	154	181
050	582	613	394	436	579	776	970	1151	1339	0	209	118	177	181

Note:

1. Coil weight is the operating weight.
2. Filter section weight includes filter media.

Motor Weight (kg)

Motor kW	0.18	0.37	0.55	0.75	1.1	1.5	2.2	3.0	3.7	4.0	5.5	7.5	11	15
Weight, kg	7.8	12	15	20	22	30	42	65	76	118	139	189	203	290

Motor kW	18.5	22	30	37	45	55	75
Weight, kg	320	348	355	500	520	550	580

General Data

VDT - Unit Dimensions

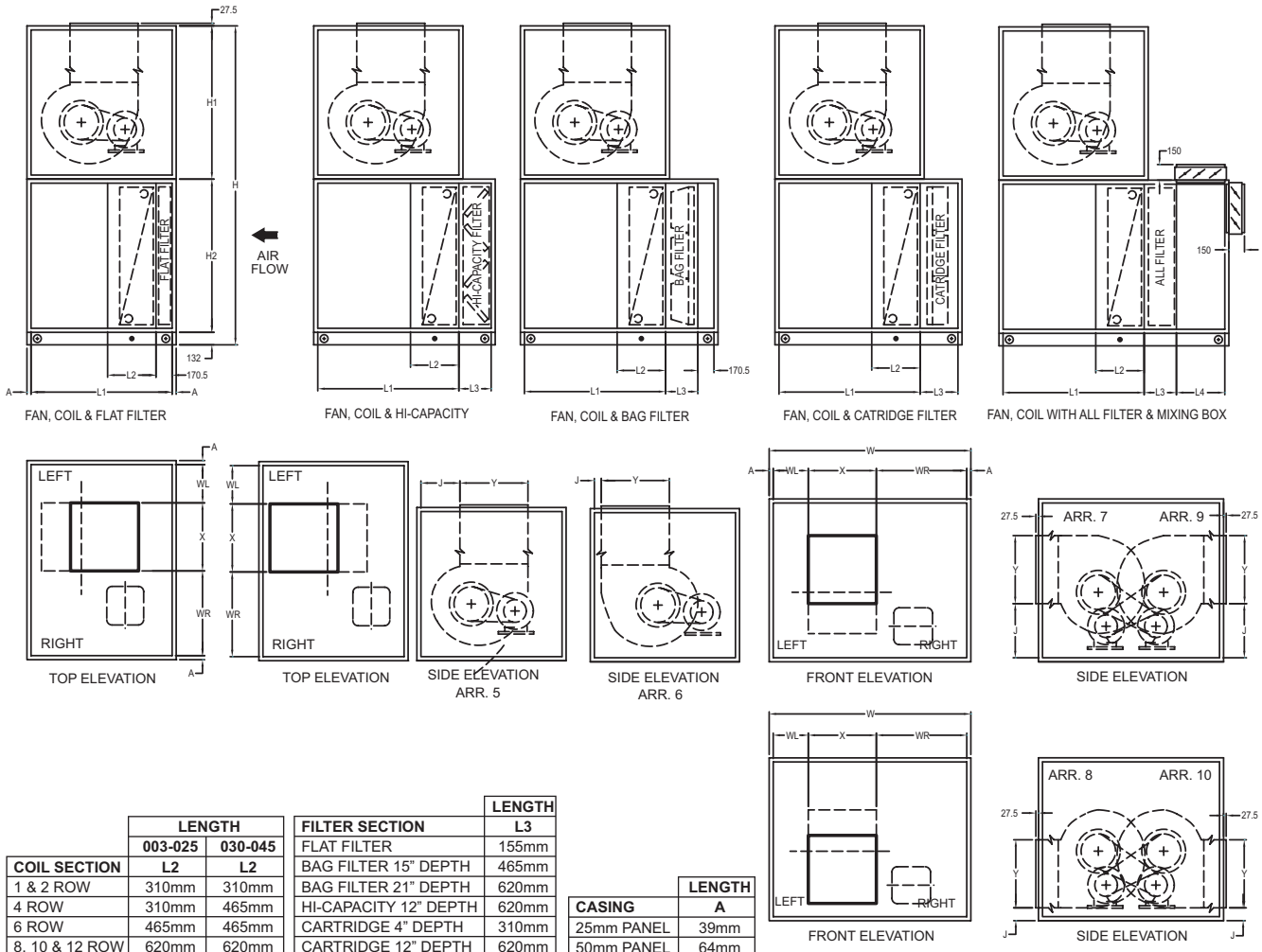

COIL SECTION	LENGTH		FILTER SECTION	LENGTH L3
	L2	L2		
1 & 2 ROW	310mm	310mm	FLAT FILTER	155mm
4 ROW	310mm	465mm	BAG FILTER 15" DEPTH	465mm
6 ROW	465mm	465mm	BAG FILTER 21" DEPTH	620mm
8, 10 & 12 ROW	620mm	620mm	HI-CAPACITY 12" DEPTH	620mm
			CARTRIDGE 4" DEPTH	310mm
			CARTRIDGE 12" DEPTH	620mm

CASING	LENGTH A
	25mm PANEL
50mm PANEL	64mm

MODEL	FAN	MOTOR KW	FAN ARR				FAN SECTION		MOTOR ACCESS				X	Y	FLAT FILTER W/ MIX. SEC L4	1" CASING				2" CASING			
			J				L1		RH		LH					H	W	H1	H2	H	W	H1	H2
			ARR 7,9	ARR 8,10	ARR 6	ARR 5	ARR 5,6	ARR 7,8,9,10	WL	WR	WL	WR											
003(0404)	F/BDB 200	0.18 - 3	221	115	100	185	930	930	175	175	175	175	270	270	310	1516	698	698	698	1616	748	748	748
004(0604)	F/BDB 225	0.37 - 3	236	115	99	217	930	930	155	468	468	155	307	307	310	1516	1008	698	698	1616	1058	748	748
006(0804)	F/BDB 250	0.55 - 7.5	246	116	97	227	930	930	199	702	702	199	340	340	310	1516	1318	698	698	1616	1368	748	748
008(1004)	F/BDB 280	0.75 - 7.5	194	46	98	247	1085	1085	336	837	837	336	378	378	310	1516	1628	698	698	1616	1678	748	748
010(0806)	F/BDB 315	1.1 - 7.5	283	115	96	264	1085	1085	161	657	657	161	422	422	310	2136	1318	1008	1008	2236	1368	1058	1058
	11 - 15	1240					1085	409	409	409													
012(1006)	F/BDB 400	1.1 - 15	337	116	97	318	1240	1085	209	817	817	209	524	524	310	2136	1628	1008	1008	2236	1678	1058	1058
014(1206)	F/BDB 400	1.5 - 15	337	116	97	318	1240	1085	349	987	987	349	524	524	310	2136	1938	1008	1008	2236	1988	1058	1058
016(1008)	F/BDB 450	1.5 - 7.5	365	117	99	345	1240	1085	227	738	738	227	586	586	310	2756	1628	1318	1318	2856	1678	1368	1368
	11 - 18.5	1550					1395																
020(1208)	F/BDB 500	2.2 - 18.5	387	117	100	368	1395	1240	266	938	938	266	656	656	310	2756	1938	1318	1318	2856	1988	1368	1368
025(1210)	F/BDB 560	2.2 - 15	446	145	100	401	1550	1395	276	851	851	276	732	732	465	3376	1938	1628	1628	3476	1988	1678	1678
	18.5 - 30	1860					1550																
030(1212)	F/BDB 560	3 - 15	446	145	100	401	1550	1395	276	851	851	276	732	732	465	3996	1938	1938	1938	4096	1988	1988	1988
	18.5 - 30	1860					1550																
035(1412)	F/BDB 630	4 - 22	540	196	100	443	1550	1395	294	1058	1058	294	818	818	465	3996	2248	1938	1938	4096	2298	1988	1988
	30 - 45	1705					1705																
040(1612)	F/BDB 710	4 - 22	589	198	100	489	1705	1550	406	1158	1158	406	916	916	620	3996	2558	1938	1938	4096	2608	1988	1988
	30 - 45	1860					1705																
045(1812)	F/BDB 710	4 - 22	589	198	100	489	1705	1550	561	1313	1313	561	916	916	620	3996	2868	1938	1938	4096	2918	1988	1988
	30 - 45	1860					1705																

Dimensional Data VDT – Unit Weight

VDT Unit Weight (kg) – Fan and Coil Section (without motor weight)

50mm Casing

Model Size	Fan Section Weight (kg)		Coil Section Weight (kg)						
	Fan Arrangement		Coil Row						
	Front-Top Front-Bottom Back-Top & Back- Bottom	Top-Front & Top-Back	1	2	4	6	8	10	12
003	107	107	76	78	87	100	113	123	134
004	121	121	94	98	111	132	150	167	184
006	175	175	112	117	135	162	186	209	232
008	205	205	139	146	168	204	233	262	288
010	228	228	151	159	186	226	261	295	330
012	254	267	187	197	230	281	326	370	414
014	272	286	211	223	263	324	378	431	484
016	355	370	246	260	306	372	432	490	550
020	471	486	264	281	335	414	486	557	629
025	582	599	336	357	423	518	606	692	780
030	609	627	396	420	500	616	725	833	942
035	773	792	438	468	560	695	822	948	1074

25mm Casing

Model Size	Fan Section Weight (kg)		Coil Section Weight (kg)						
	Fan Arrangement		Coil Row						
	Front-Top Front-Bottom Back-Top & Back- Bottom	Top-Front & Top-Back	1	2	4	6	8	10	12
003	88	88	70	72	81	95	107	118	129
004	99	99	79	82	96	116	134	151	168
006	146	146	94	99	116	144	168	190	213
008	169	167	115	121	144	179	209	237	264
010	189	189	127	135	162	201	237	270	305
012	211	220	156	166	199	249	295	338	383
014	224	235	177	189	228	290	344	396	450
016	296	307	203	217	262	328	389	447	507
020	400	412	221	238	292	371	443	514	586
025	491	504	274	295	361	456	544	630	717
030	520	534	328	353	432	548	657	765	875
035	657	671	366	395	487	622	749	875	1001

Note:

1. Coil weight is the operating weight.

Motor Weight (kg)

Motor kW	0.18	0.37	0.55	0.75	1.1	1.5	2.2	3.0	3.7	4.0	5.5	7.5	11	15
Weight, kg	7.8	12	15	20	22	30	42	65	76	118	139	189	203	290

Motor kW	18.5	22	30	37	45	55	75
Weight, kg	320	348	355	500	520	550	580



Dimensional Data VDT – Unit Weight

VDT Unit Weight (kg) – Fan + Coil + Filter Section (without motor weight)

50mm Casing

Model Size	Fan Section Weight (kg)		Coil Section Weight (kg)							Filter Section Weight (kg)			
	Fan Arrangement		Coil Row							2" Flat Filter	2" Hi-Capacity Filter	2" Flat Filter + 15" Bag Filter	2" Flat Filter + 4" Cartridge Filter
	Front-Top, Front-Bottom, Back-Top & Back-Bottom	Top-Front & Top-Back	1	2	4	6	8	10	12				
003	107	107	76	78	87	100	113	123	134	0	47	36	29
004	121	121	94	98	111	132	150	167	184	0	57	38	34
006	175	175	112	117	135	162	186	209	232	0	68	44	43
008	205	205	139	146	168	204	233	262	288	0	81	50	50
010	228	228	151	159	186	226	261	295	330	0	84	55	54
012	254	267	187	197	230	281	326	370	414	0	101	62	63
014	272	286	211	223	263	324	378	431	484	0	111	70	74
016	355	370	246	260	306	372	432	490	550	0	117	71	80
020	471	486	264	281	335	414	486	557	629	0	128	74	90
025	582	599	336	357	423	518	606	692	780	0	149	83	105
030	609	627	396	420	500	616	725	833	942	0	165	96	116
035	773	792	438	468	560	695	822	948	1074	0	193	106	134

25mm Casing

Model Size	Fan Section Weight (kg)		Coil Section Weight (kg)							Filter Section Weight (kg)			
	Fan Arrangement		Coil Row							2" Flat Filter	2" Hi-Capacity Filter	2" Flat Filter + 15" Bag Filter	2" Flat Filter + 4" Cartridge Filter
	Front-Top, Front-Bottom, Back-Top & Back-Bottom	Top-Front & Top-Back	1	2	4	6	8	10	12				
003	88	88	70	72	81	95	107	118	129	0	42	31	26
004	99	99	79	82	96	116	134	151	168	0	48	31	31
006	146	146	94	99	116	144	168	190	213	0	58	34	39
008	169	167	115	121	144	179	209	237	264	0	70	39	46
010	189	189	127	135	162	201	237	270	305	0	72	43	49
012	211	220	156	166	199	249	295	338	383	0	88	49	57
014	224	235	177	189	228	290	344	396	450	0	97	55	68
016	296	307	203	217	262	328	389	447	507	0	103	55	74
020	400	412	221	238	292	371	443	514	586	0	112	58	83
025	491	504	274	295	361	456	544	630	717	0	131	66	98
030	520	534	328	353	432	548	657	765	875	0	146	77	108
035	657	671	366	395	487	622	749	875	1001	0	172	85	125

Note:

1. Coil weight is the operating weight.
2. Filter section weight includes filter media.

Motor Weight (kg)

Motor kW	0.18	0.37	0.55	0.75	1.1	1.5	2.2	3.0	3.7	4.0	5.5	7.5	11	15
Weight, kg	7.8	12	15	20	22	30	42	65	76	118	139	189	203	290

Motor kW	18.5	22	30	37	45	55	75
Weight, kg	320	348	355	500	520	550	580



Dimensional Data VDT – Unit Weight

VDT Unit Weight (kg) – Fan + Coil + Filter and Mixing Sections (without motor weight)

50mm Casing

Model Size	Fan Section Weight (kg)		Coil Section Weight (kg)							Filter Section Weight (kg)				Mixing Box/Rear or Top Inlet Section Weight (kg)
	Fan Arrangement		Coil Row							2" Flat Filter	2" Hi-Capacity Filter	2" Flat Filter + 15" Bag Filter	2" Flat Filter + 4" Cartridge Filter	
	Front-Top, Front-Bottom, Back-Top & Back-Bottom	Top-Front & Top-Back	1	2	4	6	8	10	12					
003	107	107	76	78	87	100	113	123	134	0	47	36	29	38
004	121	121	94	98	111	132	150	167	184	0	57	38	34	45
006	175	175	112	117	135	162	186	209	232	0	68	44	43	54
008	205	205	139	146	168	204	233	262	288	0	81	50	50	64
010	228	228	151	159	186	226	261	295	330	0	84	55	54	66
012	254	267	187	197	230	281	326	370	414	0	101	62	63	76
014	272	286	211	223	263	324	378	431	484	0	111	70	74	81
016	355	370	246	260	306	372	432	490	550	0	117	71	80	104
020	471	486	264	281	335	414	486	557	629	0	128	74	90	111
025	582	599	336	357	423	518	606	692	780	0	149	83	105	115
030	609	627	396	420	500	616	725	833	942	0	165	96	116	134
035	773	792	438	468	560	695	822	948	1074	0	193	106	134	148

25mm Casing

Model Size	Fan Section Weight (kg)		Coil Section Weight (kg)							Filter Section Weight (kg)				Mixing Box/Rear or Top Inlet Section Weight (kg)
	Fan Arrangement		Coil Row							2" Flat Filter	2" Hi-Capacity Filter	2" Flat Filter + 15" Bag Filter	2" Flat Filter + 4" Cartridge Filter	
	Front-Top, Front-Bottom, Back-Top & Back-Bottom	Top-Front & Top-Back	1	2	4	6	8	10	12					
003	88	88	70	72	81	95	107	118	129	0	42	31	26	35
004	99	99	79	82	96	116	134	151	168	0	48	31	31	42
006	146	146	94	99	116	144	168	190	213	0	58	34	39	51
008	169	167	115	121	144	179	209	237	264	0	70	39	46	60
010	189	189	127	135	162	201	237	270	305	0	72	43	49	62
012	211	220	156	166	199	249	295	338	383	0	88	49	57	68
014	224	235	177	189	228	290	344	396	450	0	97	55	68	71
016	296	307	203	217	262	328	389	447	507	0	103	55	74	89
020	400	412	221	238	292	371	443	514	586	0	112	58	83	95
025	491	504	274	295	361	456	544	630	717	0	131	66	98	98
030	520	534	328	353	432	548	657	765	875	0	146	77	108	114
035	657	671	366	395	487	622	749	875	1001	0	172	85	125	127

Note:

1. Coil weight is the operating weight.
2. Filter section weight includes filter media.

Motor Weight (kg)

Motor kW	0.18	0.37	0.55	0.75	1.1	1.5	2.2	3.0	3.7	4.0	5.5	7.5	11	15
Weight, kg	7.8	12	15	20	22	30	42	65	76	118	139	189	203	290

Motor kW	18.5	22	30	37	45	55	75
Weight, kg	320	348	355	500	520	550	580

Installation Consideration

Define Unit Handling Left Or Right

Unit handling, LEFT or Right for coil connectors, drain, door location & etc. is expressed when facing the airflow through the coil.

CLCP : HDT

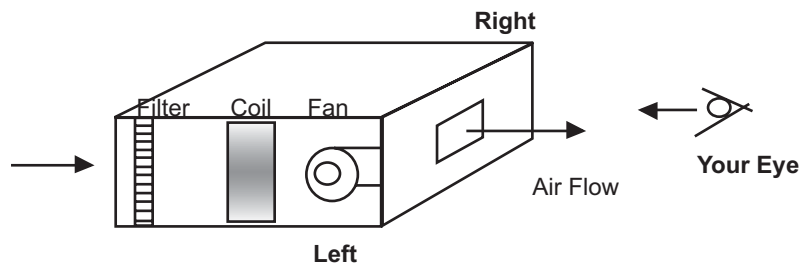

CLCP : VDT

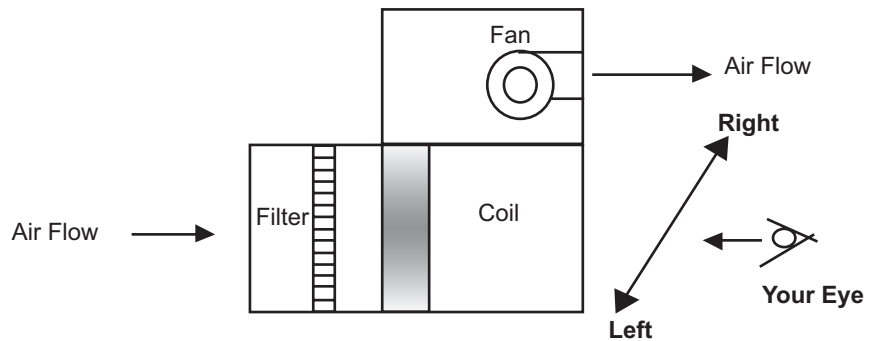

CLCP : VDT

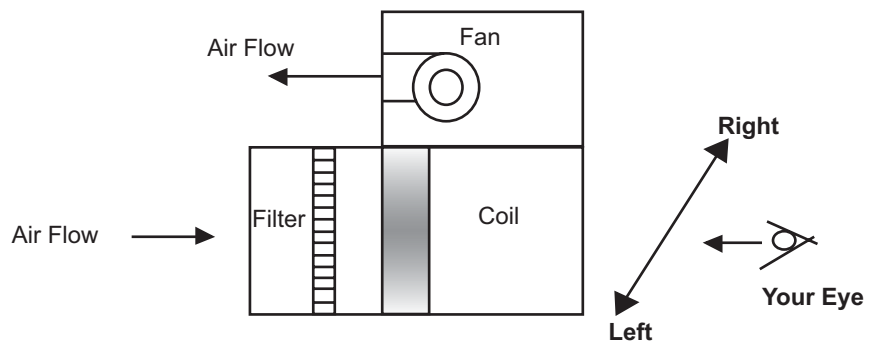

Installation Consideration Service Clearance

The purpose of this section is to provide Quantum Climate Changer job site installation consideration. Refer to installation, Operation and Maintenance manual for detailed installation information.

When selecting and preparing the unit site, follow these guidelines:

1. Ensure that the site can support the total weight of the unit.
2. Allow sufficient space for service access. The below figure give the recommended space allowances for filters, coil removal, fan shaft removal and motor starter maintenance. As unit configurations will vary, refer to unit submittals for specific location of access doors, accessories, motor starter, etc.
3. Confirm that the foundation of the mounting platform is large enough to include the unit dimensions plus services access. Refer to unit submittals for specific dimension. Certain unit maybe suspended from the ceiling. The recommended method for ceiling suspending air handler is with structural channels that run the full length of the unit. The factory shall provide the support with an external support at the base. Do not suspend air handler from the top of the unit. Serious safety risks exist if the unit is not suspended in the proper manner.
4. The floor or foundation must be level for proper coil drainage and condensate flow.
5. Allow the proper height for coil piping and condensate drain requirements. It may be necessary to elevate the unit when piping the condensate drain. Insufficient height could inhibit condensate drainage and result in flooding the unit or equipment room.
6. Provide adequate lighting for maintenance personnel to perform maintenance duties.
7. Provide permanent power outlets in close proximity of the unit for installation and maintenance.

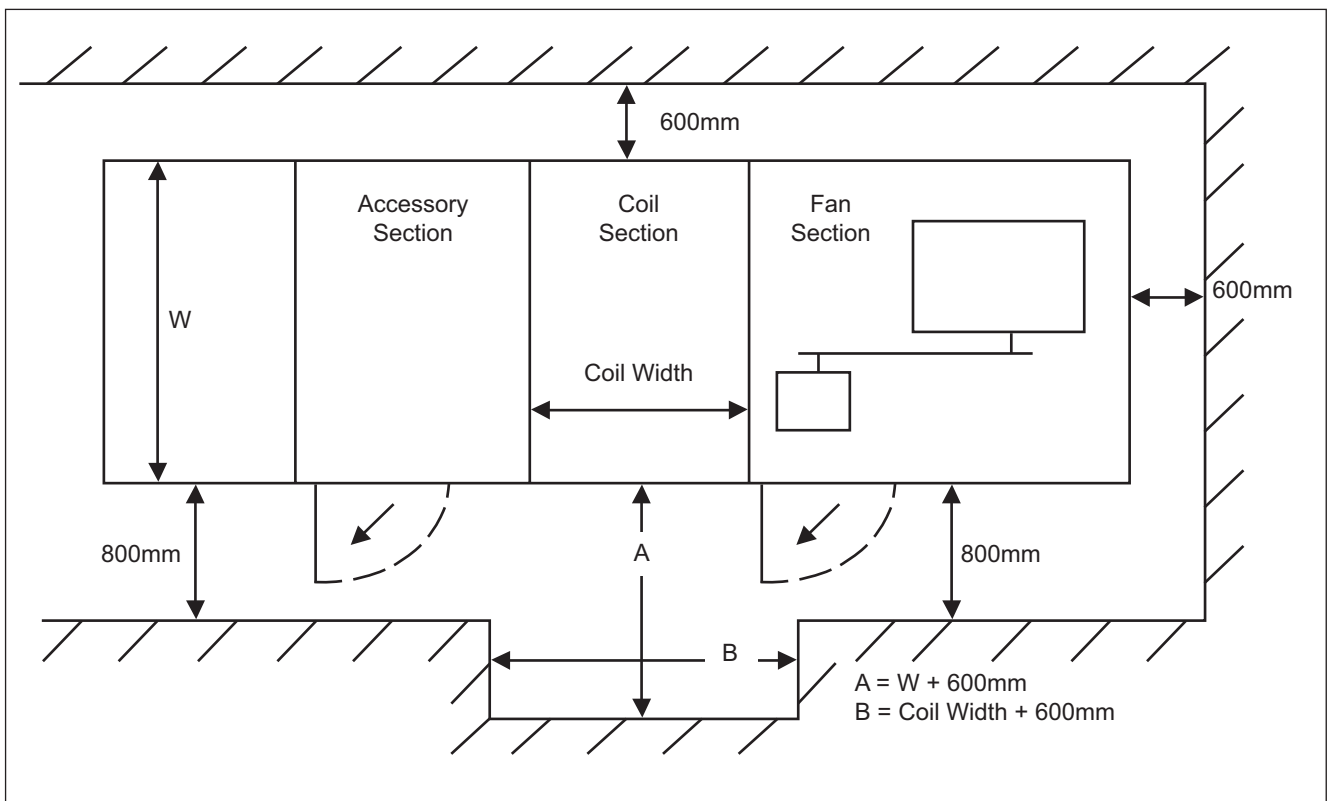

Access Side Clearances

Installation Consideration Coil Connection Dimension

50 mm Casing Construction

HORIZONTAL / VERTICAL DRAW THROUGH - CHILLED AND HOT WATER COIL CONNECTION DIMENSION

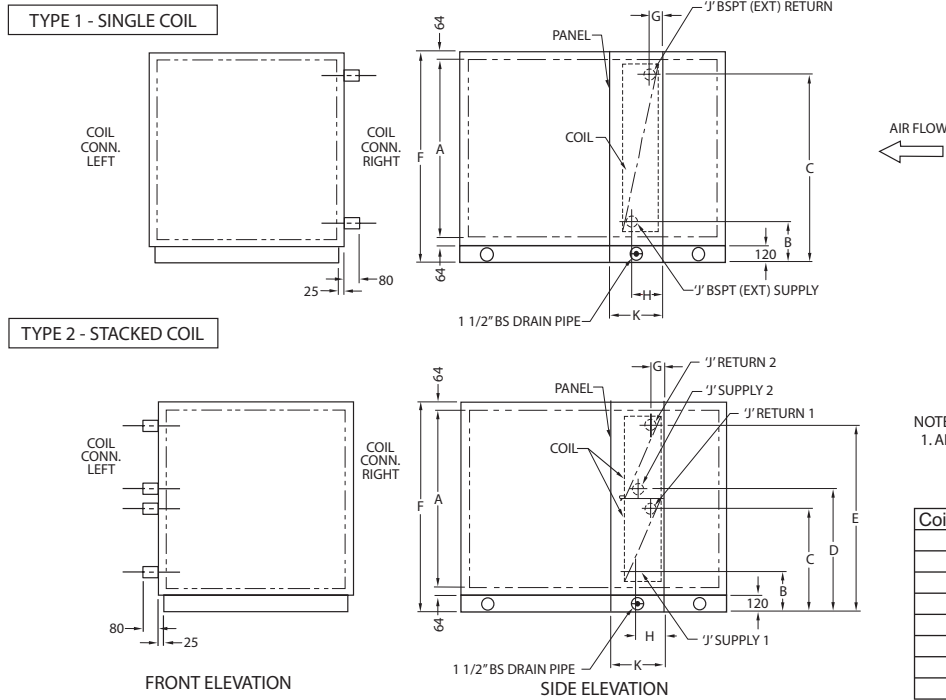

NOTE:
1. ALL DIMENSION IN MM.

Coil Row	Type	G	H	K	Model
1	HW	72	120	310	003-095
2	CW & HW	70	118	310	003-095
4	CW & HW	72	154	310	003-025
4	CW & HW	72	154	465	003-095
6	CW	72	210	465	003-095
8	CW	72	265	620	003-095
10	CW	72	320	620	003-095
12	CW	72	375	620	003-095

Model	Type	A	B	C	D	E	F	Steel Pipe External Threaded Connection Diameter (ID)				Copper Non Threaded Header Diameter (OD)							
								(2 Row)		(4, 6, 8, 10 & 12 Row)		(1 Row)	(2 Row)		(4, 6, 8, 10 & 12 Row)				
								WL & DL Coil	WL Coil	LL Coil	DL Coil	WL Coil	WL & DL Coil	WL Coil	LL Coil	DL Coil			
003	1	620	265	727	-	-	868	'J'	'J'	'J'	'J'	'J'	'J'	'J'	'J'	'J'	'J'	'J'	'J'
004	1	620	265	727	-	-	868	40	40	65	40	41	41	41	67	41	41	67	41
006	1	620	265	727	-	-	868	40	40	65	40	41	41	41	67	41	41	67	41
008	1	620	265	727	-	-	868	40	40	65	40	41	41	41	67	41	41	67	41
010	1	930	265	1065	-	-	1178	50	50	65	50	41	54	54	67	54	54	67	54
012	1	930	265	1065	-	-	1178	50	50	65	50	41	54	54	67	54	54	67	54
014	1	930	265	1065	-	-	1178	50	50	65	50	41	54	54	67	54	54	67	54
016	1	1240	265	1349	-	-	1488	50	65	65	65	41	54	67	67	67	67	67	67
020	1	1240	265	1349	-	-	1488	50	65	65	65	41	54	67	67	67	67	67	67
025	1	1550	265	1635	-	-	1798	50	65	65	65	41	54	67	67	67	67	67	67
030	2	1860	265	1070	1175	1960	2108	50	50	65	50	41	54	54	67	54	54	67	54
								50	50	65	50	41	54	54	67	54	54	67	54
035	2	1860	265	1070	1175	1960	2108	50	50	65	50	41	54	54	67	54	54	67	54
								50	50	65	50	41	54	54	67	54	54	67	54
040	2	1860	265	1070	1175	1960	2108	50	50	65	50	41	54	54	67	54	54	67	54
								50	50	65	50	41	54	54	67	54	54	67	54
045	2	1860	265	1070	1175	1960	2108	50	50	65	50	41	54	54	67	54	54	67	54
								50	50	65	50	41	54	54	67	54	54	67	54
050	2	1860	265	1070	1175	1960	2108	50	50	65	50	41	54	54	67	54	54	67	54
								50	50	65	50	41	54	54	67	54	54	67	54
060	2	2170	265	1265	1370	2290	2418	50	65	65	65	41	54	67	67	67	67	67	67
								50	65	65	65	41	54	67	67	67	67	67	67
065	2	2170	265	1265	1370	2290	2418	50	65	65	65	41	54	67	67	67	67	67	67
								50	65	65	65	41	54	67	67	67	67	67	67
070	2	2170	265	1265	1370	2290	2418	50	65	65	65	41	54	67	67	67	67	67	67
								50	65	65	65	41	54	67	67	67	67	67	67
080	2	2170	265	1265	1370	2290	2418	50	65	65	65	41	54	67	67	67	67	67	67
								50	65	65	65	41	54	67	67	67	67	67	67
085	2	2170	265	1265	1370	2290	2418	50	65	65	65	41	54	67	67	67	67	67	67
								50	65	65	65	41	54	67	67	67	67	67	67
090	2	2170	265	1265	1370	2290	2418	50	65	65	65	41	54	67	67	67	67	67	67
								50	65	65	65	41	54	67	67	67	67	67	67
095	2	2170	265	1265	1370	2290	2418	50	65	65	65	41	54	67	67	67	67	67	67
								50	65	65	65	41	54	67	67	67	67	67	67

Installation Consideration Coil Connection Dimension

25 mm Casing Construction

HORIZONTAL / VERTICAL DRAW THROUGH - CHILLED AND HOT WATER COIL CONNECTION DIMENSION

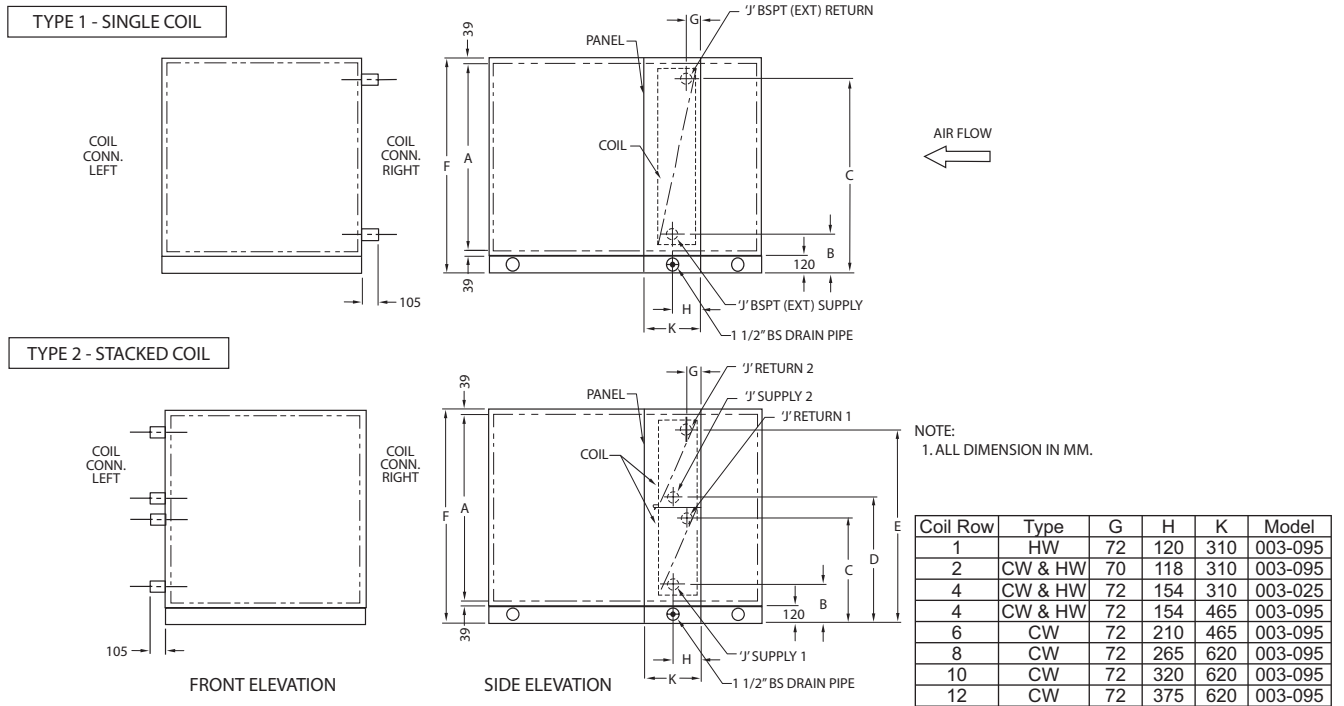

Model	Type	A	B	C	D	E	F	Steel Pipe External Threaded Connection Diameter (ID)				Copper Non Threaded Header Diameter (OD)								
								(2 Row)		(4, 6, 8, 10 & 12 Row)		(1 Row)	(2 Row)		(4, 6, 8, 10 & 12 Row)					
								WL & DL Coil	WL Coil	LL Coil	DL Coil	WL Coil	WL & DL Coil	WL Coil	LL Coil	DL Coil				
003	1	620	240	702	-	-	818	'J'	'J'	'J'	'J'	'J'	'J'	'J'	'J'	'J'	'J'	'J'	'J'	
004	1	620	240	702	-	-	818	40	40	65	40	41	41	41	67	41	41	41	67	41
006	1	620	240	702	-	-	818	40	40	65	40	41	41	41	67	41	41	41	67	41
008	1	620	240	702	-	-	818	40	40	65	40	41	41	41	67	41	41	41	67	41
010	1	930	240	1040	-	-	1128	50	50	65	50	41	54	54	67	54	54	54	67	54
012	1	930	240	1040	-	-	1128	50	50	65	50	41	54	54	67	54	54	54	67	54
014	1	930	240	1040	-	-	1128	50	50	65	50	41	54	54	67	54	54	54	67	54
016	1	1240	240	1324	-	-	1438	50	65	65	65	41	54	67	67	67	67	67	67	67
020	1	1240	240	1324	-	-	1438	50	65	65	65	41	54	67	67	67	67	67	67	67
025	1	1550	240	1610	-	-	1748	50	65	65	65	41	54	67	67	67	67	67	67	67
030	2	1860	240	1045	1150	1935	2058	50	50	65	50	41	54	54	67	54	54	54	67	54
035	2	1860	240	1045	1150	1935	2058	50	50	65	50	41	54	54	67	54	54	54	67	54
040	2	1860	240	1045	1150	1935	2058	50	50	65	50	41	54	54	67	54	54	54	67	54
045	2	1860	240	1045	1150	1935	2058	50	50	65	50	41	54	54	67	54	54	54	67	54
050	2	1860	240	1045	1150	1935	2058	50	50	65	50	41	54	54	67	54	54	54	67	54
060	2	2170	240	1165	1346	2266	2368	50	65	65	65	41	54	67	67	67	67	67	67	67
065	2	2170	240	1165	1346	2266	2368	50	65	65	65	41	54	67	67	67	67	67	67	67
070	2	2170	240	1165	1346	2266	2368	50	65	65	65	41	54	67	67	67	67	67	67	67
080	2	2170	240	1165	1346	2266	2368	50	65	65	65	41	54	67	67	67	67	67	67	67
085	2	2170	240	1165	1346	2266	2368	50	65	65	65	41	54	67	67	67	67	67	67	67
090	2	2170	240	1165	1346	2266	2368	50	65	65	65	41	54	67	67	67	67	67	67	67
095	2	2170	240	1165	1346	2266	2368	50	65	65	65	41	54	67	67	67	67	67	67	67

Mechanical Specifications

General

The units must be rigged and lifted in strict accordance with the Installation Operation and Maintenance manual. The units are to be installed in strict accordance with the specifications.

Units may be shipped fully assembled or disassembled to the minimum module size in accordance with shipping or jobsite requirements. Units shall have break point if manufacturer found appropriate for easy handling and transportation.

Unit Construction

The casing shall have a perimeter frame with a modular system based on standardized double wall panels. Removal of side panels must not affect the structural integrity of the unit. Casing strength shall be designed to meet European Standard EN 1886:1998.

The framework shall be made from non-corrosive recyclable extruded aluminum channels fitted together non-metal corner pieces.

The casing panel shall be attached to the frame through a self-locking mechanism represented by a wedge and frame, exerting pressure evenly onto the panel and seal attached to the frame, and hence a better air tight cabinet construction. The casing shall be designed to meet Eurovent air leakage requirement.

The casing shall be able to withstand up to 8 inches of total static pressure. Closed-cell foam gasketing shall be provided where modules are joined.

The floor panels shall have double wall construction to allow maintenance personnel access without damage to the insulation.

The whole unit shall be mounted on a galvanized sheet steel base frame for ease of shipment and handling. The minimum height of the floor-mounting base shall be 120mm and designed to ensure air circulation and avoid entrapment of moisture below the unit. The base frame is to be used in lieu of concrete plinths or other additional bases that are used on site. However for high static pressure application additional concrete plinths or other additional bases is required at site to raise the AHU for drain pan's U-trap.

Double-Wall Panel

The outer panel wall shall be painted with baked polyester powder paint that is resistant to scratch and nicks and shall allow for easy cleaning. The inner wall shall be galvanized steel. The paint shall be ultra violet resistant, weather resistant for outdoor application, offering excellent weather resistance properties.

The panels shall be 50mm or 25mm thick double wall type with injected polyurethane foam insulation for a rigid non-vibration construction. The panel insulation shall not absorb moisture and must be rot resistant. The insulation material shall be totally enclosed in the panel to avoid any possibility of insulation being exposed to air stream. The panel insulation shall have a heat transfer "K" value of 0.02 w/mK. Exposed Insulation system shall meet UL 94, standard for safety and flame-ability of plastic material for parts in devices and appliances. The panels shall be flush mounted, leaving no exposed gaps between panels and frame, to minimize potential air leaks.

Drain Pans

Coil, moisture eliminator and humidifier shall be provided with an insulated, galvanized or stainless steel (option), dual pitch sloping drain pan to allow for proper condensate removal. The galvanized drain pan shall be painted with a mastic compound (bitumen) for corrosion protection.

Access and Inspection Doors

Access doors shall be constructed with a double-wall panel that compresses evenly a durable seal onto a rigid frame. The seal around the full perimeter of the access door's frame shall be used to prevent air leakage. The doors shall be hinged and able to be lifted off or removed totally for easy access.

View Window

A view window shall be made of 4mm thick transparent Plexiglas's type on inner and outer wall panel with a rubber grommet seal and fitted on double wall panel. The size shall be 150 x 150mm. The mounting location shall be flexible and upon customer's requirement. Special window size shall be an option.

Mechanical Specifications

Service Light

A factory-mounted, weather-resistant (enclosed and gasketed), vapor-tight, light fixture shall be provided. Fixture shall be equipped with plastic switch box, single phase wiring, PL lamp comes with ballast and reflector.

Fan Module

The fan assembly shall be checked and dynamically balanced to ISO1940 on equivalent. Fan shaft shall be properly size and protectively coated. Fan wheels shall be keyed to fan shaft to prevent slipping. Fan shafts shall be solid and designed so that fan shaft does not pass through its first critical speed as the unit comes up to its rated rpm. Fan modules shall be provided with an access door. Access side for both side of fan shall be an option.

FC Fan Modules

Fan shall be double-width, double-inlet, and multi-blade type as produced by the unit manufacturer. Fan shall be forward curved (FC) as required for stable operation, low noise and optimum energy efficiency. Fan shall be equipped with bearings with an L-50 life (average life) of up to 200,000 hours. The multi blade shall be made of galvanized steel and the solid shaft shall be made of carbon steel: C45, machined and polished to tolerance of standard ISO 286-2-Grade G6. Protective coat of anti rusting shall be applied to all bare surfaces of shafts at the factory. The fans shall be licensed to bear the AMCA Air and Sound Certified Ratings seal. The test standard used shall be ANSI/AMCA 210, ANSI/ASHRAE Standard 51 "Laboratory Method of Testing Fans for Rating" and AMCA 300 "Reverberant Room method for Sound Testing of fans".

BC Fan Modules

Fan shall be double-width, double-inlet, and multiblade type as produced by the unit manufacturer. Fan shall be backward curve (BC) as required for stable operation, high static pressure and optimum energy efficiency. Fan shall be equipped with bearings with an L-50 life (average life) of up to 200,000 hours. The multiple blades shall be made of treated steel with paint for corrosion resistant. The solid shaft shall be made of carbon steel: C45, machined and polished to tolerance of standard ISO 286-2-Grade G6. Protective coat of anti rusting shall be applied to all bare surfaces of shafts at the factory. The fans shall be licensed to bear the AMCA Air and Sound Certified Ratings seal. The test standard used shall be ANSI/AMCA 210, ANSI/ASHRAE Standard 51 "Laboratory Method of Testing Fans for Rating" and AMCA 300 "Reverberant Room Method for Sound Testing of Fans".

AF Fan Modules

Shall be customized upon request. The fan shall be double-width, double-inlet, multiple blade type as produced by the unit manufacturer. Fan shall be backward inclined airfoil (AF).

Fan Modulation

- a) Inlet Guide Vanes (Option)
For variable air volume applications, airflow of BC fan type fans shall be modulated by inlet guide vanes. Actuator shall be provided as an option.
- b) Variable Frequency Drive (Option)
For variable air volume applications, airflow shall be modulated by a variable frequency drive controlling fan speed.

Fan Isolation

Fan connection shall be isolated from unit casing by a flexible canvas duct mounted at fan discharge outlet.

- a) Rubber-In-Shear Isolators
Fan and motor assembly shall be internally isolated from the unit casing with rubber-in-shear isolators, furnished and installed by the unit manufacturer.
- b) One-Inch Spring Isolators (Option)
Fan and motor assembly shall be internally isolated from the unit casing with 1-inch deflection spring isolators, furnished and installed by the unit manufacturer.
- c) Two-Inch Spring Isolators (Option)
Fan and motor assembly shall be internally isolated from the unit casing. The isolation system shall be designed to take higher isolation efficiency than 1" spring isolator.

Drives

The drive assembly shall consist of V-belt taper-lock pulley and electric motor. The V-belt type shall be SPZ, SPA, SPB or SPC grades, oil and heat resistant, antistatic and avoiding electric discharges. The pulley and shaft assembly shall be using taper-lock bush with Allen set screws for easy and quick assemble and dis-assemble process. Drive shall be selected at 1.5 service factor.

- a) Variable Pitch (Option)
Drives shall be variable pitch, suitable for adjustment within ± 5 percent of specified rpm. Drives shall be limited to two grooves maximum to ensure good alignment. This option shall only use for installing motor Hp that below 25Hp or 18.5 kW due to design limitation.
- b) Fixed Pitch
Drives shall be constant speed with fixed pitch sheaves.

Mechanical Specifications

Motors

Motor shall be mounted integral to an isolated fan assembly furnished by the unit manufacturer. Motor shall be mounted inside the unit casing on a sliding base to permit adjustment of drive belt tension.

Standard motor shall be horizontal foot mounting, induction motor, squirrel cage, totally enclosed fan-cooled with IP55 protection with class F insulation and suitable for operation at ambient temperature of 40 degree C.

Motor Options

- a) 380-415 Volt /3 pH /50 Hz (Standard)
- b) 200 Volt /3 pH /50Hz
- c) 200 Volt /3 pH /60 Hz
- d) 230 Volt /3 pH /60 Hz
- e) 380 Volt /3 pH /60 Hz
- f) 440 Volt /3 pH /60 Hz
- g) 460 Volt /3 pH /60 Hz
- h) High Efficiency Motors
- i) Premium Efficiency Motor
- j) USA's Motor
- k) European's Motor
- l) Explosion Proof Motor
- m) Dual Speed Motor

Fan Module Option

Belt guard unit shall be provided with a painted metal sheet belt guard.

Coil Module

Coil shall be installed such that unit casing enclose headers and return bends. Coil shall be designed to maximize the utilization of the available unit cross-section area. Coil

connections shall be clearly labeled on outside of units. Coil shall be cartridge type mounted on steel channel for easy removability. Coils shall have aluminum fins and seamless copper tubes. Coated aluminum (for corrosion protection used near the sea) and copper fins shall be an option. The fins shall be sine-wave design with slits for better heat transfer efficiency and moisture carry-over limit performance. Fins shall have collars drawn, belled and firmly bonded to tubes by mechanical expansion of the tubes. Capacities, pressure drops and selection procedure shall be designed in accordance with ARI Standard 410. The copper tube shall be 0.5 inch OD.

Coil casing shall be 1.5mm thick galvanized steel (standard) or stainless steel (option) or with formed end supports and top and bottom channels. Coil casing shall be a series of drain holes at the bottom channels to insure condensate drainage.

If stacked coil in the unit, intermediate drainpan shall be installed between coils to drain condensate to the main drain pans without flooding the lower coils or passing condensate through the airstream of the lower coil. The coil working pressure at site shall not exceed the leak test value on each coil type given below.

Water Coils

Supply and return headers shall be clearly labeled on the outside of the unit to ensure that direction of coil water flow is counter to direction of unit air-flow. Coils shall be tested to 375 psig.

The headers shall be constructed of round steel pipe with BSPT external threaded. All headers shall be fitted with air venting and water draining plug.

Header connection option

- Unthreaded copper header connection
- Copper header with BSPT external threaded brass adaptor for quick job site connection.
- Steel header with steel flanges for quick job site connection.

Refrigerant Cooling Coils

Suction and liquid line connections plate fins and seamless copper tubes shall be clearly labeled on the outside of the unit. Coils shall be leak tested to 450 psig (17 Bar) air pressure under water. After testing, insides of coils are to be dried; all connections are to be sealed and coils shall be shipped with a charge of dry nitrogen. Suction headers shall be constructed of cooper tubing. Suction connections shall penetrate unit casings to allow for external connections to refrigerant lines. Coils shall have equqlizing vertical distributors sized according to the capacities of the coils.

Steam Heating Coils

Steam coils shall be pitched in the unit for proper drainage of steam condensate from coils. Coils shall be leak tested to 375 psig air pressure under water. Steam header and condensate header connections are to be constructed of round steel. Steam header connection shall be located opposite with condensate header.

Mechanical Specifications

Filter Modules

Filter sections shall have filter racks, an access door for filter removal and block-offs as required to prevent air bypass around filters. Modules shall be supplied with 2-inch or 4-inch angled or high capacity, cartridge, bag and final filters. Filter shall be sized so as not to exceed scheduled face velocities.

Pleated Filter Media (Throwaway)

Filters shall be 2-inch or 4-inch thick non-woven fabric, treated with adhesive and continuously laminated to a supported steel wire grid. Filters shall have a rated average dust spot efficiency of not less than 25 to 30 percent when tested in accordance with ASHRAE 52-1-1992 atmospheric dust spot method. Filter access shall be accessed from either right or left hand side as standard. Back access shall be an option.

Washable or Permanent Filters

Filters shall be 2-inch synthetic fibers capable of operating up to 600-fpm face velocity. Filter media shall be layers of cleanable wire maze. Filter frame shall be constructed of galvanized steel. Filter access shall be accessed from either right or left hand side as standard. Back access shall be an option.

Hi-Capacity Filters

Filter shall be 2-inch throwaway as standard. Option for pleated media and washable. The filter shall be fixed in angular (Zig-zag) form for higher duct holding capacity. Filter frame shall be constructed of galvanized steel. Filter access shall be accessed from either right or left hand side a standard.

Cartridge Filters

Filter shall be constructed by pleating a continuous sheet of fine-fiber glass media into closely spaced pleats with safe-edged separators. This filter shall be sealed into a fiber boards frame assembled in a rigid manner to prevent

air leakage. All cartridge filters shall be furnished with a 2-inch prefilter to provide extended cartridge life. Filters shall have a rated average dust spot efficiency of not less than 60 percent when tested in accordance with ASHRAE 52-1-1992 atmospheric dust spot method. Manufacturer shall supply back access filter rack support and holding clips that capable of holding cartridge filters and prefilters.

Bag Filters

Filters shall be synthetic fiber media with spun backing to keep synthetic fibers from eroding downstream. Stitching method shall permit bag to retain pleat shape and air pocket when in operation without the use of wire basket support. Filters shall have a rated average dust spot efficiency of not less than 60 percent when tested in accordance with ASHRAE 52-1-1992 atmospheric dust spot method.

Factory-Mounted Direct Digital Control (DDC)

Factory-mounted DDC systems shall be engineered mounted, wired and tested by the air handling unit manufacturer to reduce installed costs, save time, and improve reliability. Each control system shall be fully functional in a standalone mode or can be tied to a building automation system with a simple pair of wires.

Direct Digital Controller

A dedicated programmable direct digital controller with the appropriate point capabilities shall be unit mounted on each air-handling unit. A screen and keypad shall be provided to facilitate local monitoring, trouble shooting and changing of set points.

Factory-Mounted Control Options

- a) Mixing Box Damper Actuators
Actuators shall be mounted with

the outside air damper linked normally closed and the return air damper linked normally open.

- b) Face/bypass Damper Actuators
Actuators shall be linked as indicated on the order and control drawings.
- c) Inlet Guide Vane Actuators
Actuators shall be mounted with the IGVs linked normally closed.
- d) Averaging Temperature Sensors
Averaging (Thermistor type) sensor shall be serpentine with capillary clips across the unit as engineered by the air handling unit manufacturer.
- e) Low-Limit Switches
A manual reset low limit switch shall be installed as an option.
- f) Airflow Switches
A differential pressure switch piped to both sides of the filter shall indicate filter status.
- g) Dirty Filter Switches
A differential pressure switch piped to both sides of the filter shall indicate filter status.
- h) Dirty Filter Switches
A differential pressure switch pipe to the discharge and suction sides of the fan shall indicate fan status.
- i) Customer Interface Relays
5 amp DPDT relays shall be provided as required for each binary output of the controller for customer interface to; supply, return and exhaust fan motor starters; relief dampers; pumps; condensing units; etc.
- j) Electronic end devices



Mechanical Specifications

Field-Mounted Control Options

Control Valves

Control valves can be provided by the air handling unit manufacturer and field piped by the piping contractor. Power and signal wiring shall be by a simple quick connect.

Space Temperature Sensors

Thermister type sensors shall be provided as required for field wiring.

Outside Air Sensors

Thermister type sensors shall be provided as required for field wiring. All factory-mounted controls shall be covered by the air handling manufacturer's standard warranty.

The manufacturer has a policy of continuous product improvement, and reserves the right to alter any details of the products at any time without notice.



Trane
www.trane.com

For more information, contact your local district office

Literature Order Number CLCP - PRC001-EN (December 2012)

File Number

Supersedes CLCP-PRC001-EN (May 2012)

Stocking Location Malaysia

Trane has a policy of continuous product and product data improvement and reserves the right to change design and specifications without notice.