

206 wiring Peugeot diagrams

Key to circuits

- Diagram 1*** Information for wiring diagrams
- Diagram 2*** Starting, charging, horn, pre/post-heating
- Diagram 3*** Pre/post heating, engine cooling fan
- Diagram 4*** Engine cooling fan, temp. gauge, seat belt warning light
- Diagram 5*** Warning lights and gauges
- Diagram 6*** Exterior lighting
- Diagram 7*** Exterior lighting continued, buzzer, interior lighting
- Diagram 8*** Interior lighting continued, headlight levelling
- Diagram 9*** Clock, cigar lighter, sunroof, audio system
- Diagram 10*** Audio system, electric windows
- Diagram 11*** Rear windows, heated rear window and mirrors
- Diagram 12*** Wash/wipe system, ABS
- Diagram 13*** Central locking
- Diagram 14*** Airbags, heater blower, air conditioning
- Diagram 15*** HDi Diesel engine management (part 1 of 2)
- Diagram 16*** HDi Diesel engine management (part 2 of 2)
- Diagram 17*** Magneti Marelli MM1AP fuel injection
- Diagram 18*** Bosch MP7.2 fuel injection

Key to symbols

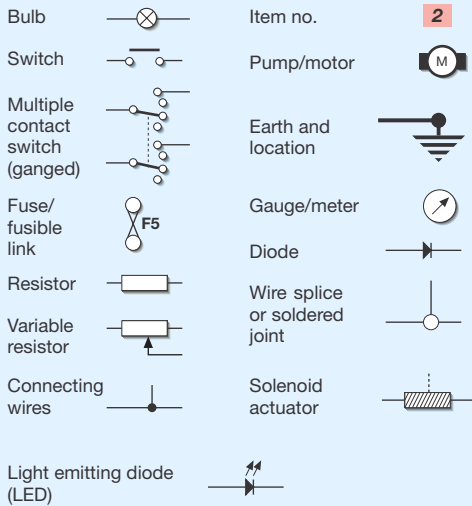

Wire identifier and colour (Orange). Note: colours may not resemble actual vehicle due to variations in production!

CC05 (OR)

Connections to other circuits. Direction of arrow denotes current flow.

Diagram 3, Arrow A
High beam warning light

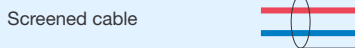

Dashed outline denotes part of a larger item, containing in this case an electronic or solid state device.

C2 - connector pin identification.

2VE - 2 pin green connector.

Key to circuits

- Diagram 1 Information for wiring diagrams
- Diagram 2 Starting, charging, horn, pre/post-heating
- Diagram 3 Pre/post heating, engine cooling fan
- Diagram 4 Engine cooling fan, temp. gauge, seat belt warning light
- Diagram 5 Warning lights and gauges
- Diagram 6 Exterior lighting
- Diagram 7 Exterior lighting continued, buzzer, interior lighting
- Diagram 8 Interior lighting continued, headlight levelling
- Diagram 9 Clock, cigar lighter, sunroof, audio system
- Diagram 10 Audio system, electric windows
- Diagram 11 Rear windows, heated rear window and mirrors
- Diagram 12 Wash/wipe system, ABS
- Diagram 13 Central locking
- Diagram 14 Airbags, heater blower, air conditioning
- Diagram 15 HDi Diesel engine management (part 1 of 2)
- Diagram 16 HDi Diesel engine management (part 2 of 2)
- Diagram 17 Magneti Marelli MM1AP fuel injection
- Diagram 18 Bosch MP7.2 fuel injection

4 Engine fuse box

Fuse	Rating	Circuit protected
MF1	70A	Built in systems interface supply
MF2	40A	Fan
MF3	-	Additional heating
MF4	-	Spare
MF8	70A	Supply passenger comp. fuse box
MF9	50A	Built in systems interface supply
MF10	40A	Main and dipped beam
MF11	60A	Supply passenger comp. fuse box (models with rear power windows)
MF12	50A	Ignition switch power supply
MF13	40A	Ignition switch power supply
MF16	30A	ABS
MF17	30A	ABS
F5	20/30A	Horn, sidelights, front foglight
F6	10/20A	Heated seats, heating, ventilation, running lights
F7	5/20A	Fan
F14	5/30A	Running lights, headlight wash, diagnostic socket
F18	-	Spare
F19	-	Spare
F20	-	Spare
F21	5A	Coolant thermostat, heating, ventilation
F22	-	Spare
F23	5A	ABS
F24	5A	Engine management, pre-heat unit, air flow sensor
F25	10A	Fuel pump
F26	10/30A	Engine man. fuel pump, oxygen sensor, EGR
F27	-	Engine man.
F28	5A	Throttle housing heater
F29	30A	Air pump
F30	10A	RH foglight, foglight warning light
F31	10A	LH foglight
F32	10A	Reversing lights, vehicle speed sensor, diesel pump, auto. gearbox electrohydraulic block, additional heating
F33	10A	Automatic gearbox
F34	5/15A	Oxygen sensor

5 Passenger fuse box (28 fuse)

F1	SH	Pretensioner unit, front and side airbags, BSI supply
F2	5A	Instrument cluster
F3	-	Spare
F4	5A	Built in systems interface (BSI)
F5	-	Spare
F6	5A	Engine management control unit, immobiliser
F7	15A	Spare
F8	10A	Coolant temp. unit, instrument panel, hazard warning, clock, multi/func. display, courtesy light
F9	5A	Built in systems interface (BSI)
F10	-	Spare
F11	10A	LH stop light, high level stop light
F12	10A	RH stop light
F13	-	Spare
F14	30A	Rear electric windows
F15	20A	Luggage compartment illumination, tow-bar supply
F16	-	Spare
F17	-	Spare
F18	10A	Number plate light, lighter illumination, clock, multifunction display, interior illum.
F19	5A	Rear foglights
F20	-	Spare
F21	-	Spare
F22	10A	Glove box light, map reading light, courtesy light, clock or multi/func. display, instrument panel, on-board navigation system, rear electric windows, rain sensor
F23	20A	Cigar lighter
F24	15A	Radio
F25	20A	Windscreen wiper and rear wiper
F26	-	Spare
F27	5A	Built in systems interface (BSI)
F28	-	Spare

25 Passenger fuse box (12 fuse)

F29	10A	LH main beam
F30	10A	RH main beam, main beam warning light
F31	10A	LH dipped beam
F32	10A	RH dipped beam, dipped beam warning light
F33	5A	Headlight wash
F34	10A	LH side/tail light
F35	10A	RH side/tail light
F36	-	Spare
F37	5A	Coolant temperature unit
F38	5A	Fan, pressostat
F39	-	Spare
F40	20/40A	Heating, ventilation

Wire colours

BA White	OR Orange
BE Blue	RS Red
BG Beige	RS Pink
GR Grey	VE Green
JN Yellow	VJ Mauve
MR Brown	VJ Green/ Yellow
NR Black	

Key to items

1 Battery	5 Passenger fusebox (28 fuse)	14 TDC sensor	21 Post heat relay
2 Ignition switch	6 Starter motor	15 Vehicle speed sensor	22 EGR function supply relay
3 Instrument cluster	7 Alternator	16 Injection supply relay	23 Post heat thermal switch
a = alternator warning light	8 Diagnostic connector	17 Pre-heat control unit	24 EGR valve
b = speedometer	9 Built in systems interface (BSI)	18 Glow plugs	
c = tachometer	10 Multifunction switch	19 Diesel injection pump	
d = glow plug warning light	a = horn switch	a = control unit	
e = control unit	11 Horn switch	b = EGR load lever switch	
4 Engine fusebox	12 Horn	c = advance correction solenoid	
a = horn relay (if fitted)	13 Steering wheel rotary connector	20 Oil pressure switch	

* Alternative wiring

Diagram 2

H32037

Starting and charging

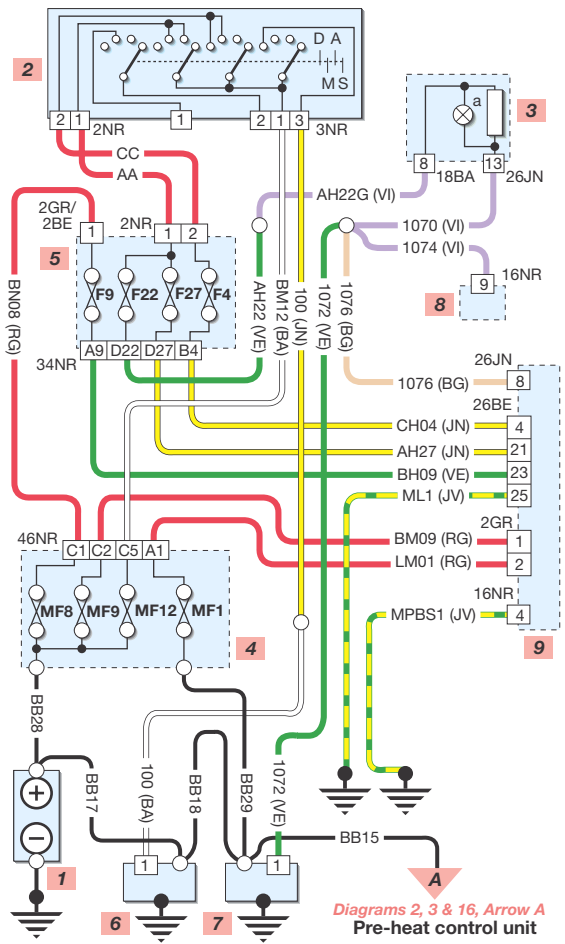

Diagrams 2, 3 & 16, Arrow A
Pre-heat control unit

Horn

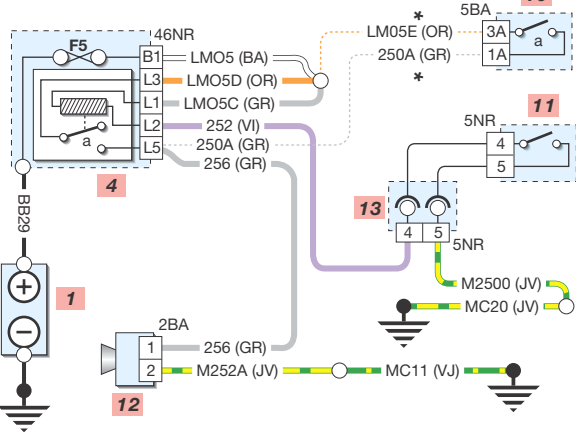

Pre/post heating - without air cond. (except HDi models)

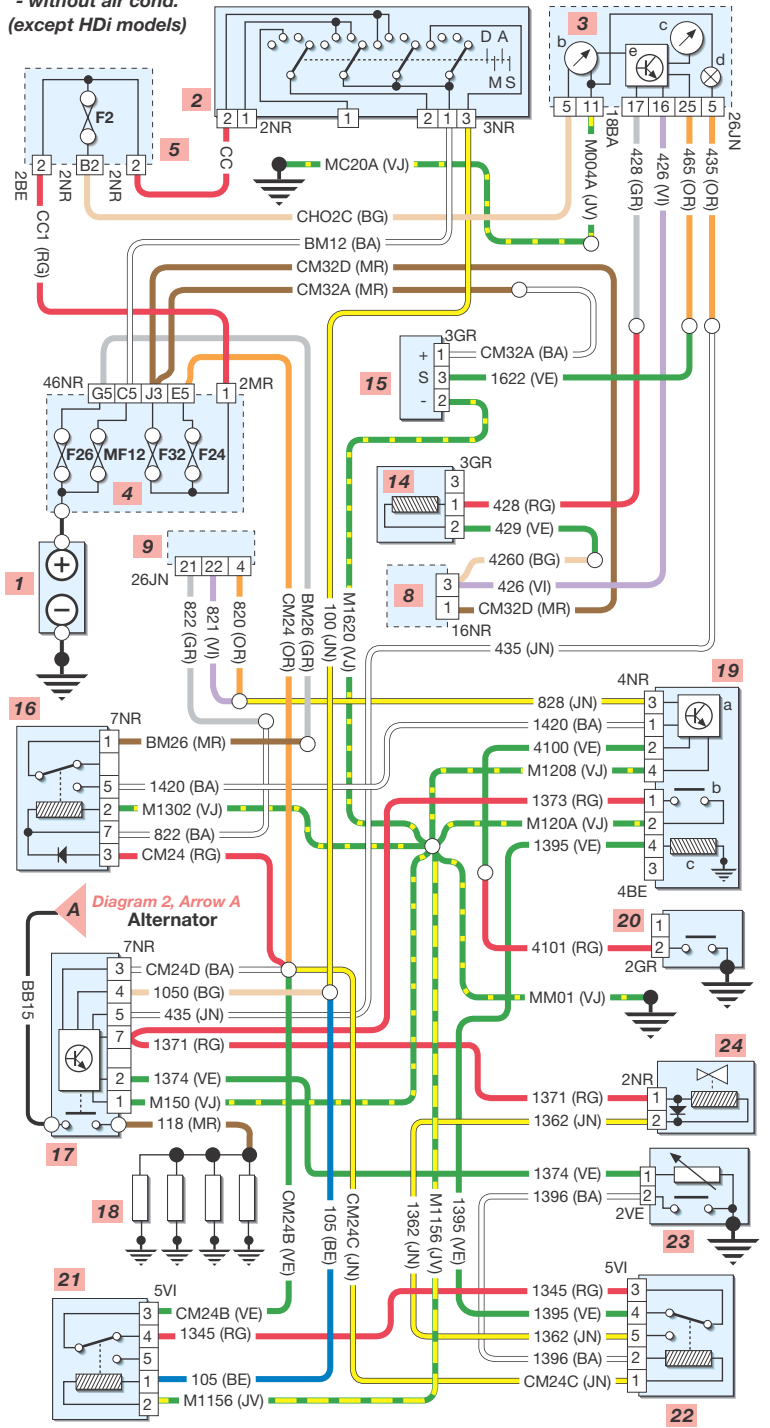

Diagram 2, Arrow A
Alternator

Wire colours

BA White	OR Orange
BE Blue	RG Red
BG Beige	RS Pink
GR Grey	VE Green
JN Yellow	VI Mauve
MR Brown	VJ Green/Yellow
NR Black	Yellow

Key to items

1 Battery	5 Passenger fusebox (28 fuse)	18 Glow plugs	24 EGR valve
2 Ignition switch	6 Starter motor	19 Diesel injection pump	30 Air cond. cut-off control unit
3 Instrument cluster	7 Alternator	a = control unit	31 Cooling fan motor
b = speedometer	8 Diagnostic connector	b = EGR load lever switch	32 Cooling fan thermal switch
c = tachometer	9 Built in systems interface (BSI)	c = advance correction solenoid	33 Diesel engine management ECU
d = glow plug warning light	14 TDC sensor	20 Oil pressure switch	34 Engine management double function relay
e = control unit	15 Vehicle speed sensor	21 Post heat relay	
4 Engine fusebox	16 Injection supply relay	22 EGR function supply relay	
b = low speed fan supply relay	17 Pre-heat control unit	23 Post heat thermal switch	

Diagram 3

H32038

Pre/post heating - with air cond. (except HDi models)

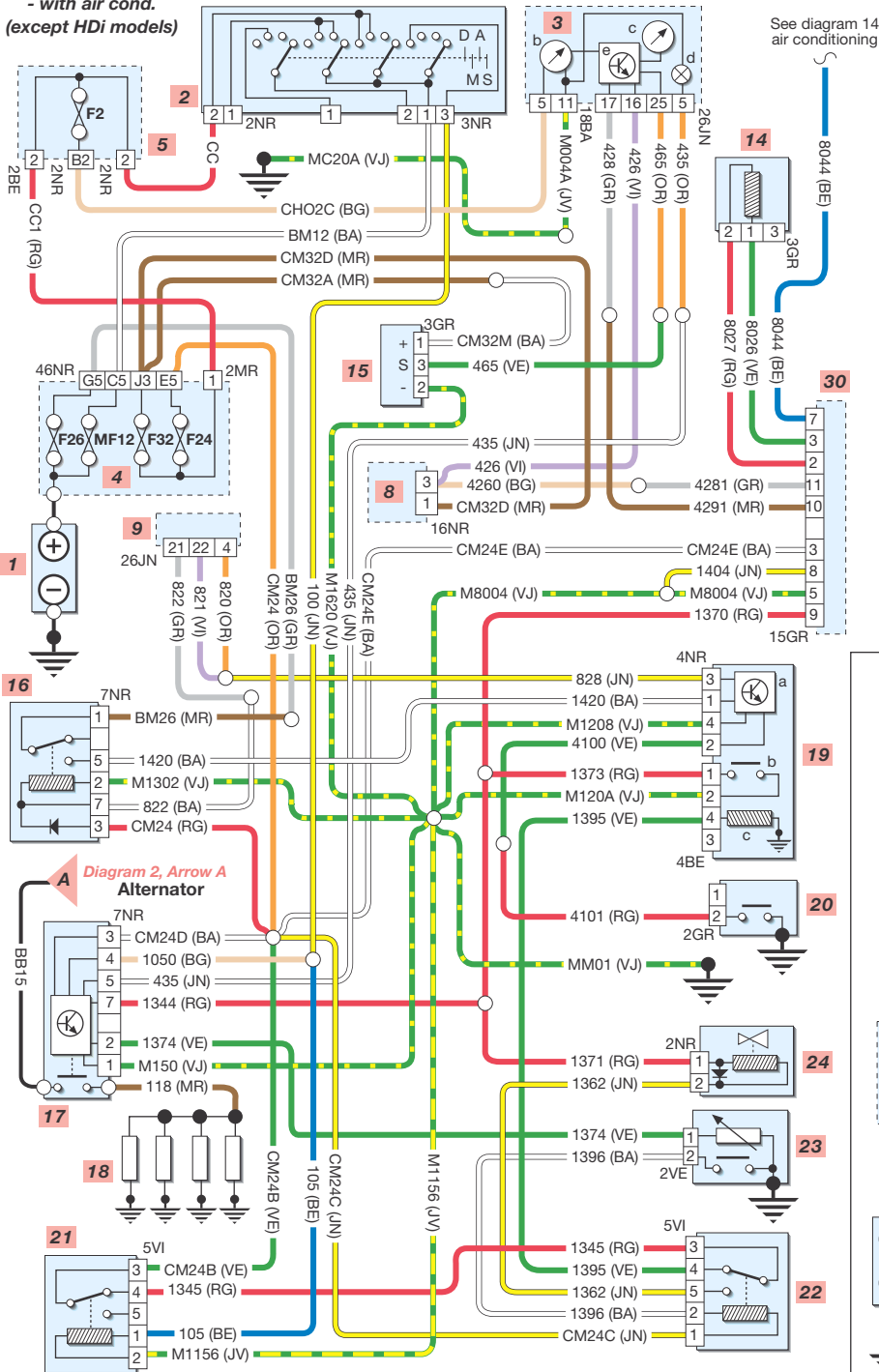

Engine cooling fan - single fan/single speed, all models (except HDi) without air cond.

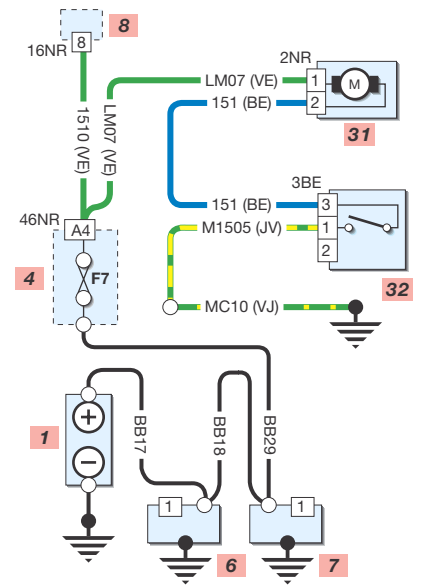

Engine cooling fan - single fan/single speed, HDi models without air cond.

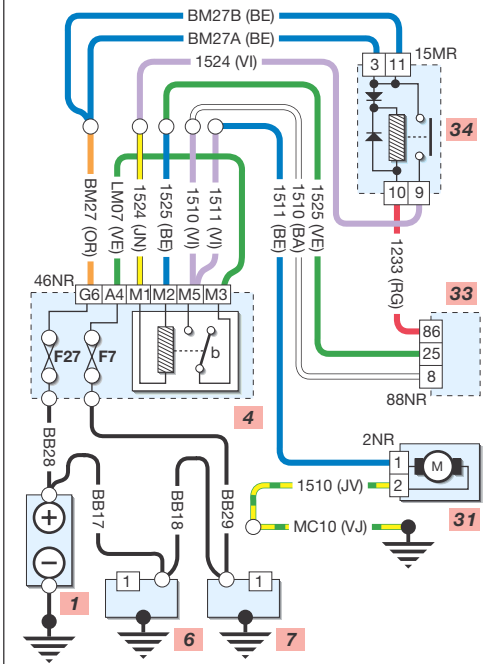

Wire colours

BA White	OR Orange
BE Blue	RG Red
BG Beige	RS Pink
GR Grey	VE Green
JN Yellow	VI Mauve
MR Brown	VJ Green/Yellow
NR Black	Yellow

Key to items

1 Battery	5 Passenger fusebox (28 fuse)	40 High speed fan supply relay
2 Ignition switch	8 Diagnostic connector	41 Twin speed fan resistor
3 Instrument cluster	25 Passenger fusebox (12 fuse)	42 Air cond. coolant temp. thermistor
e = control module	31 Cooling fan motor	43 Pressostat
f = coolant temp. gauge	33 Engine management control unit	44 Air cond. compressor
g = stop warning light	34 Engine management double function relay	45 Coolant temp. sensor/switch
h = seat belt warning light	38 Air cond. coolant temp. unit	46 Seat belt switch
4 Engine fusebox	39 Low speed fan supply relay	

Diagram 4

H32039

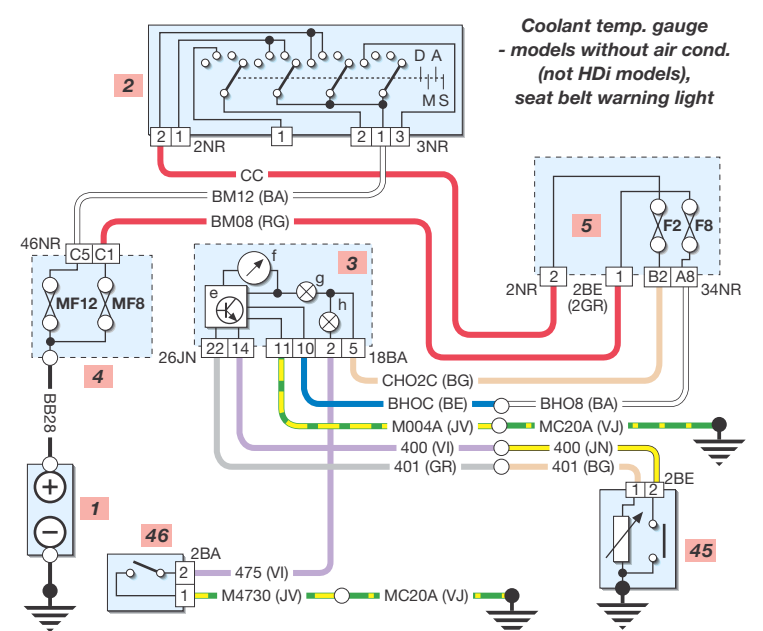
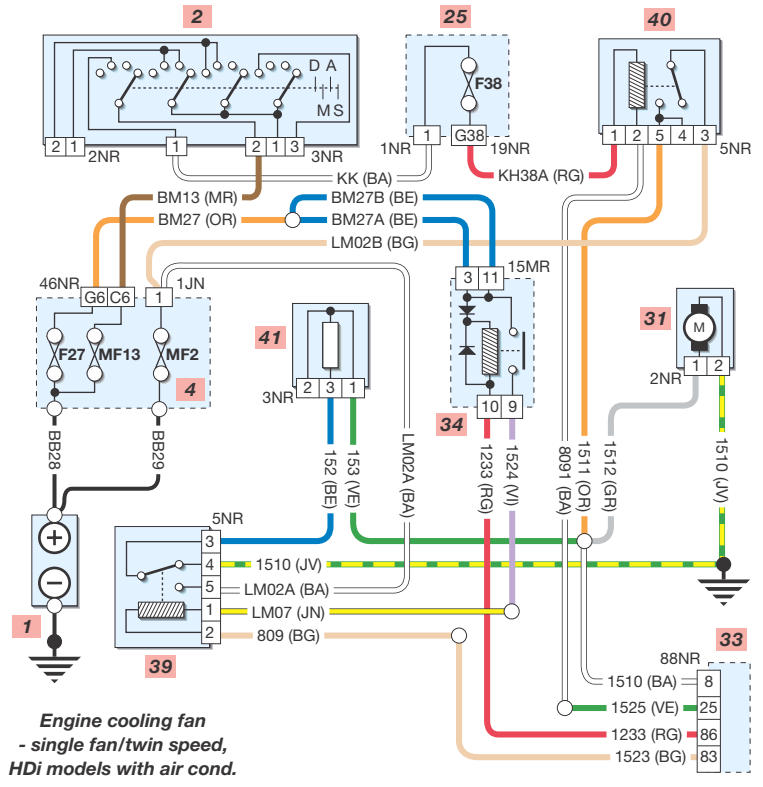
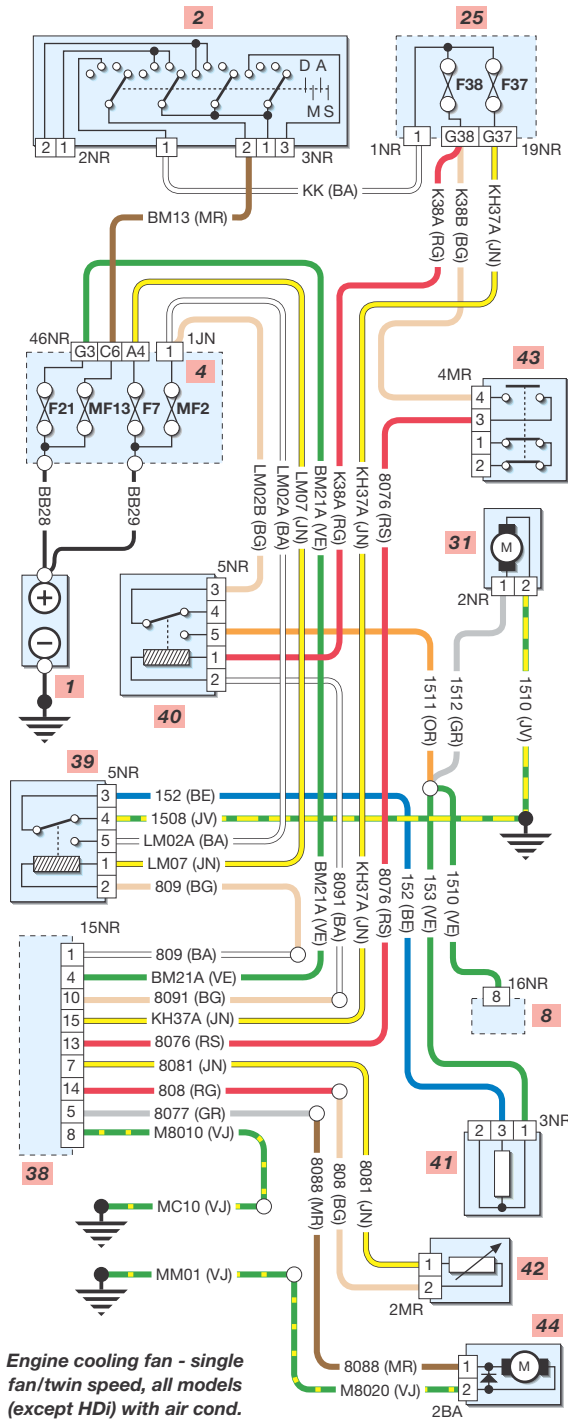

Wire colours

BA White	OR Orange
BE Blue	RG Red
BG Beige	RS Pink
GR Grey	VE Green
JN Yellow	VI Mauve
MR Brown	VJ Green/ Yellow
NR Black	

Key to items

1 Battery	25 Passenger fusebox (12 fuse)	65 Number plate light	70 RH headlight
2 Ignition switch	60 Reversing light switch (manual)	66 LH front side light	71 Rear foglight
3 Instrument cluster	61 Stop light switch	67 RH front side light	72 LH front foglight
p = dipped beam warning light	62 High level brake light	68 Multifunction switch	73 RH front foglight
q = main beam warning light	63 LH rear light cluster	a = side/headlight switch	74 Reversing light switch (auto.)
r = front foglight warning light	a = reversing light	b = dipped/main beam switch	
s = rear foglight warning light	b = stop light	c = headlight flasher	
4 Engine fusebox	c = tail light	e = rear foglight switch	
c = front foglight relay	64 RH rear light cluster	f = front foglight switch	
5 Passenger fusebox (28 fuse)	(items a to c as above)	69 LH headlight	

Diagram 6

H32041

Stop and reversing lights

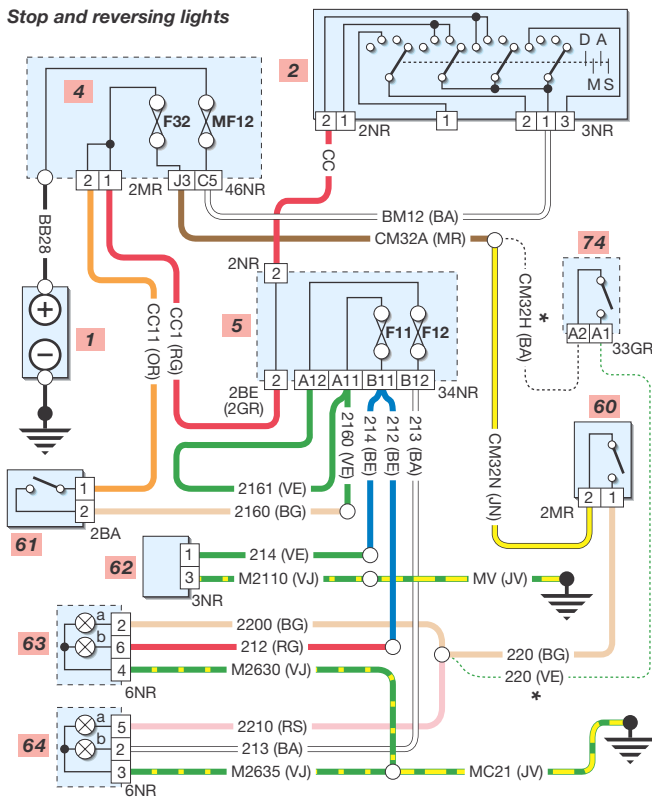

Headlights

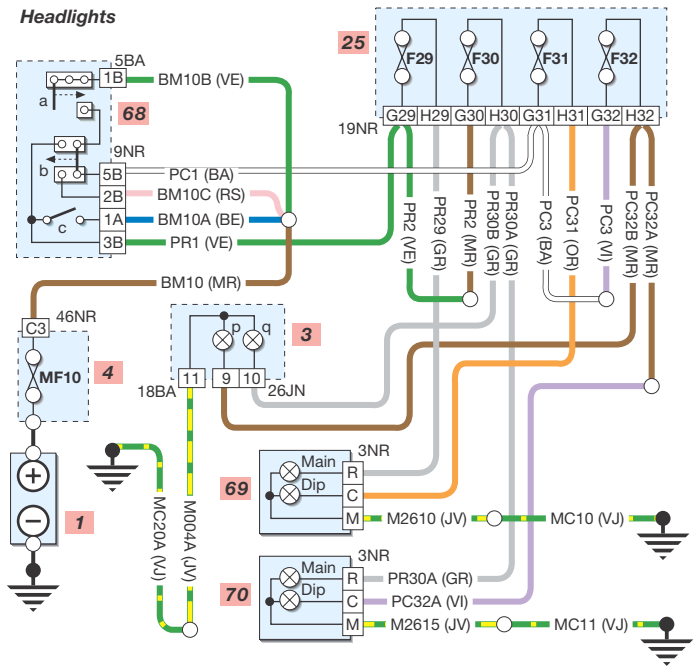

Front and rear fog lights

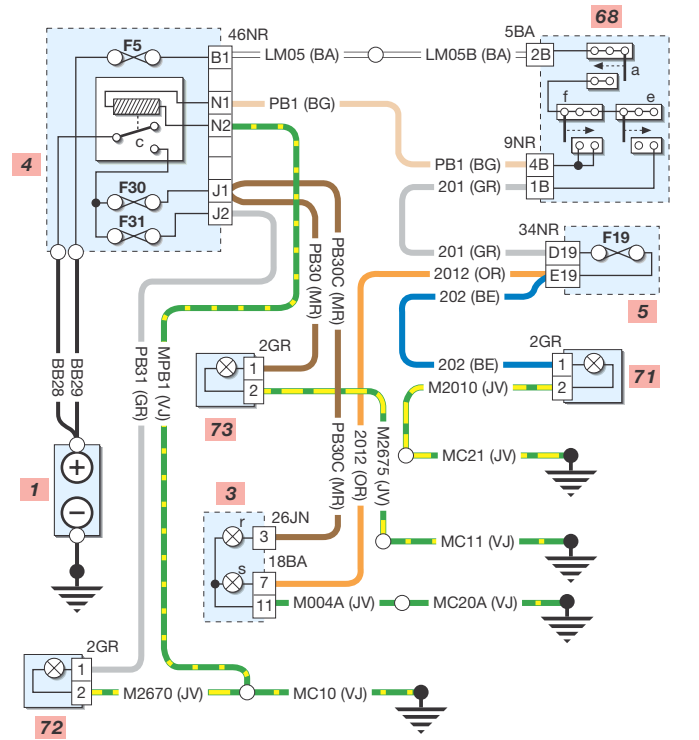

Side, tail and number plate lights

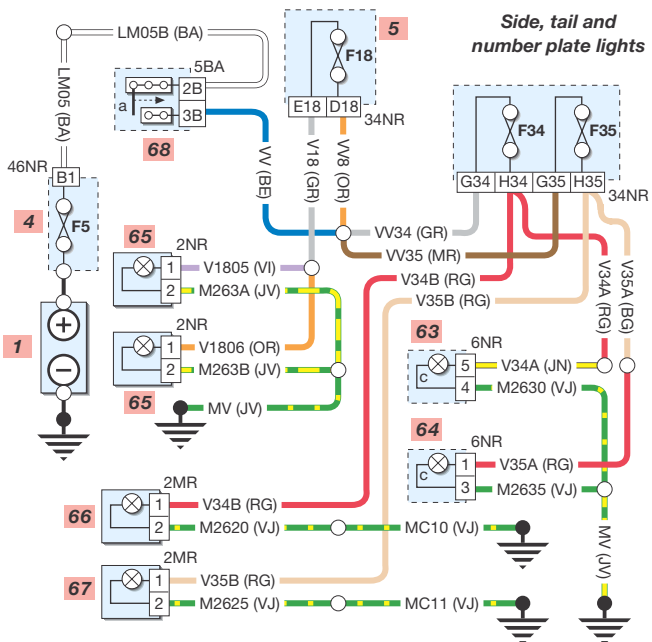

Wire colours

BA White	OR Orange
BE Blue	RG Red
BG Beige	RS Pink
GR Grey	VE Green
JN Yellow	VI Mauve
MR Brown	VJ Green/ Yellow
NR Black	

Key to items

1	Battery	83	RH front door lock assembly
2	Ignition switch	87	Interior light
4	Engine fusebox	88	Map reading light
5	Passenger fusebox (28 fuse)	89	Luggage compartment light
9	Built in systems interface (BSI)	90	Luggage compartment light switch
68	Multifunction switch	91	Glove box light
	a = side/headlight switch	92	Glove box light switch
80	LH front door contact switch	93	Headlight levelling control switch
81	RH front door contact switch	94	LH headlight levelling motor
82	LH front door lock assembly	95	RH headlight levelling motor

Diagram 8

H32043

Map reading light and interior light (models without central locking)

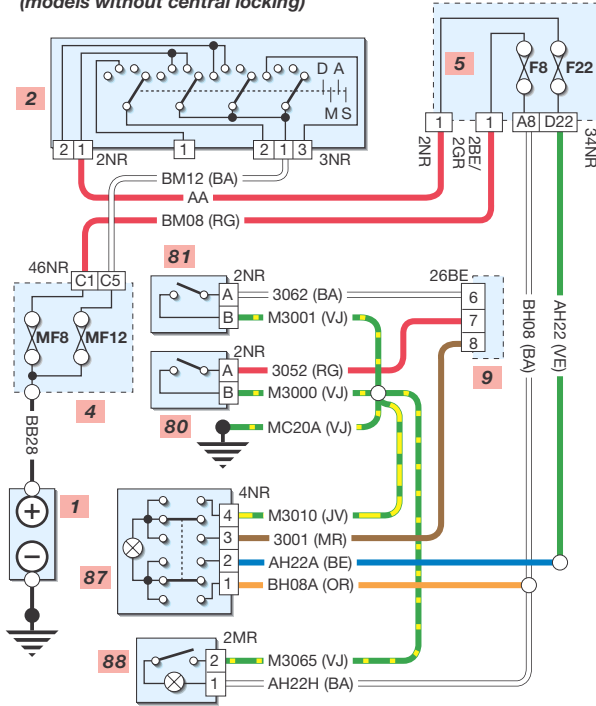

Map reading light and delayed interior light (models with central locking)

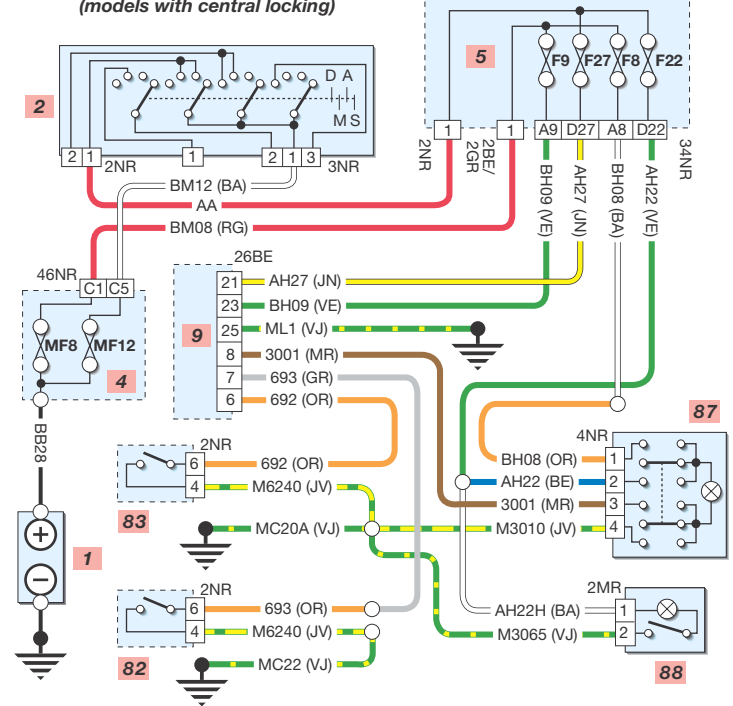

Glove box and luggage compartment light

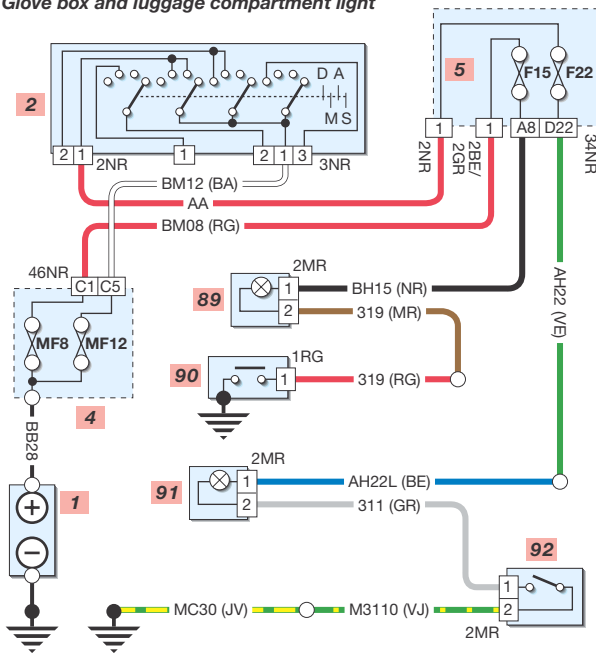

Headlight levelling

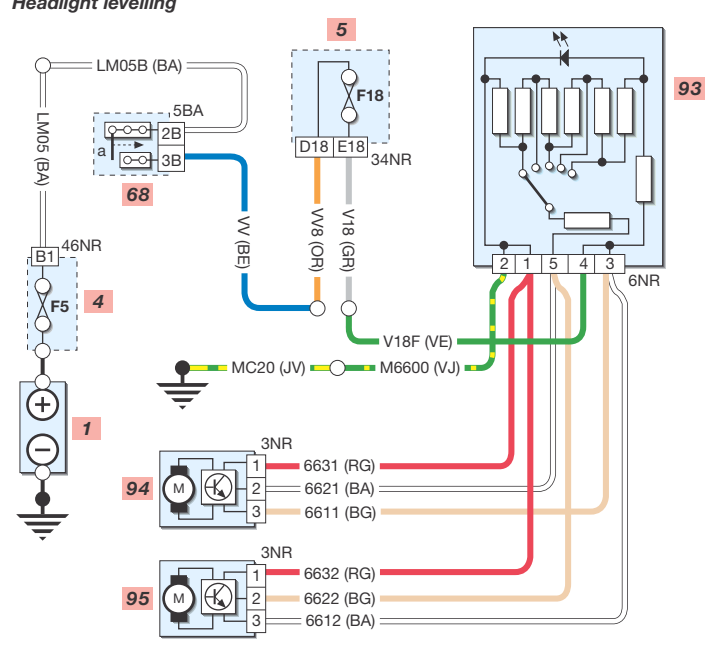

Wire colours

BA White	OR Orange
BE Blue	RG Red
BG Beige	RS Pink
GR Grey	VE Green
JN Yellow	VI Mauve
MR Brown	VJ Green/ Yellow
NR Black	

Key to items

1 Battery	104 LH tweeter
2 Ignition switch	105 Passenger's front door speaker
4 Engine fusebox	106 RH rear speaker
5 Passenger fusebox (28 fuse)	107 RH tweeter
9 Built in systems interface (BSI)	108 Driver's front door speaker
98 Cigar lighter	109 Sunroof assembly
99 Clock	
100 Audio unit (2030 model)	
101 Satellite controls	
102 Electric aerial module	
103 LH rear speaker	

Diagram 9

- * With rear power windows
- ** Without rear power windows
- *** Alternative wiring

H32044

Clock and cigar lighter

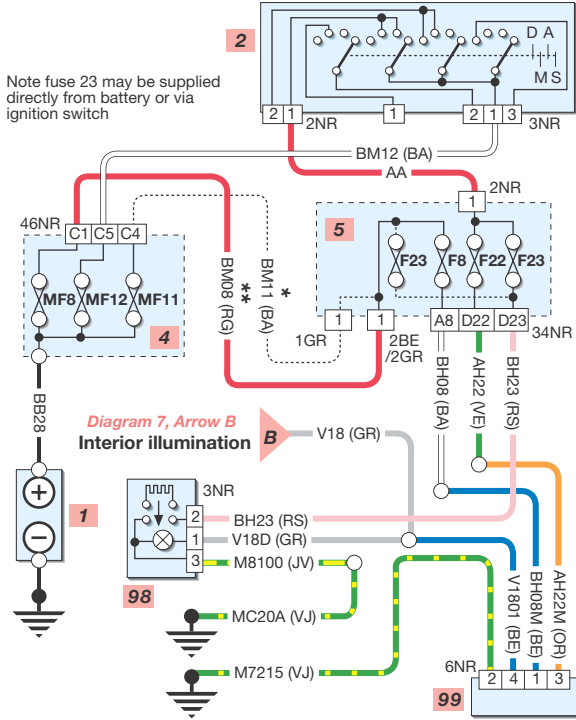

Audio unit - 2030 model

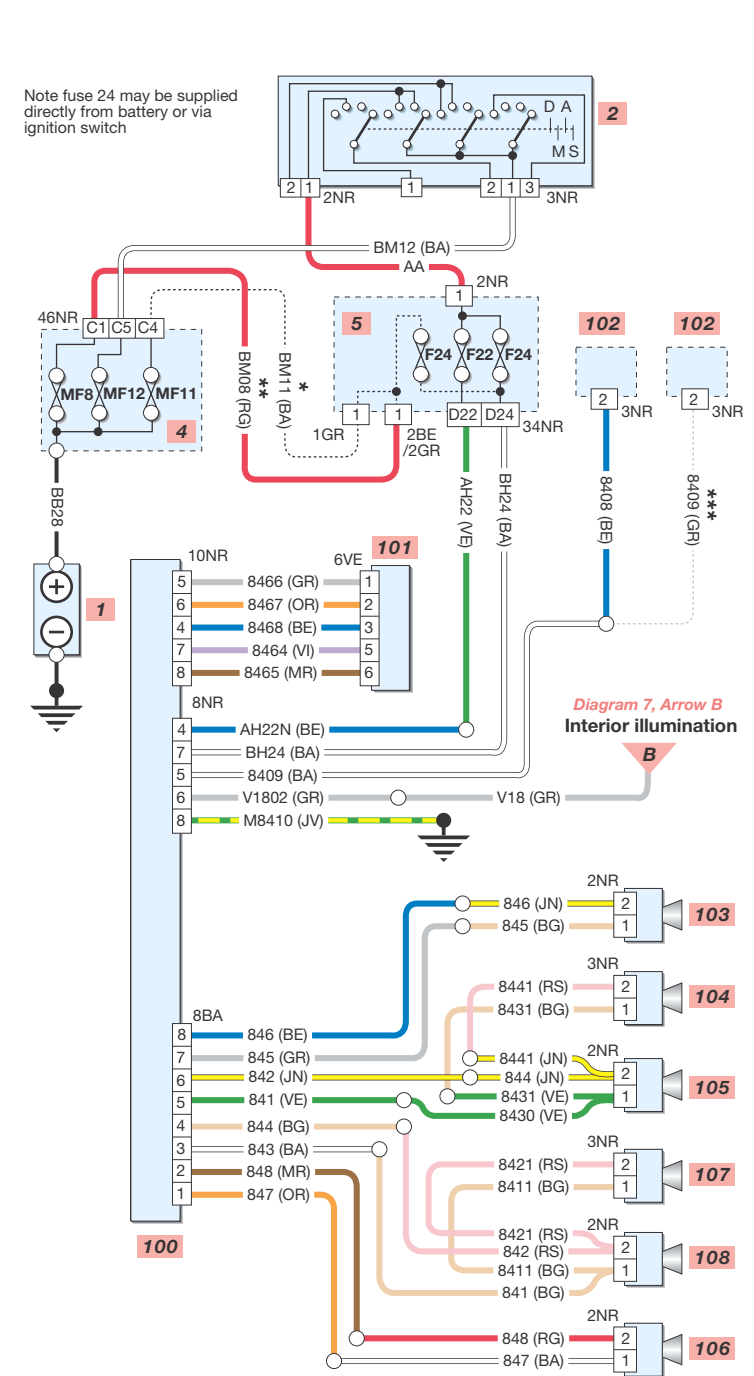

Power sunroof

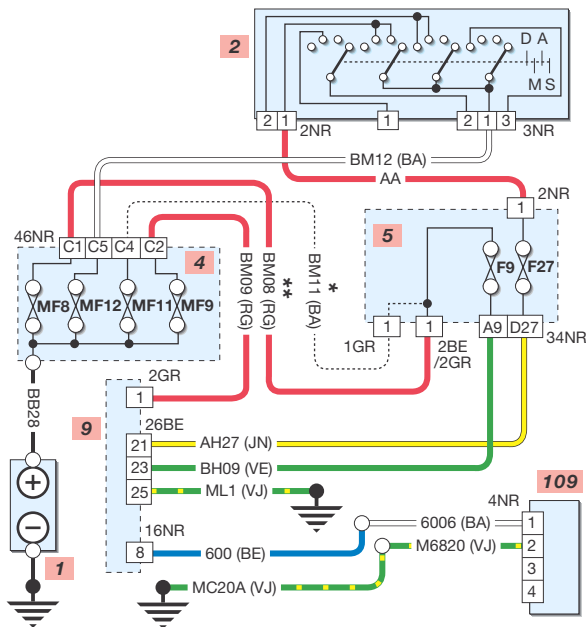

Wire colours

BA White	OR Orange
BE Blue	RG Red
BG Beige	RS Pink
GR Grey	VE Green
JN Yellow	VI Mauve
MR Brown	VJ Green/Yellow
NR Black	Yellow

Key to items

1 Battery	103 LH rear speaker	115 Passenger's mirror assembly
2 Ignition switch	104 LH tweeter	116 Window and mirror control switch
4 Engine fusebox	105 Passenger's front door speaker	117 One-touch control unit
5 Passenger fusebox (28 fuse)	106 RH rear speaker	118 Driver's window motor
9 Built-in systems interface (BSI)	107 RH tweeter	119 Passenger's window motor
100 Audio unit (2040 model)	108 Driver's front door speaker	
101 Satellite controls	113 CD player	
102 Electric aerial module	114 Multifunction display unit	

Diagram 10

H32045

Audio unit with multifunction display - 2040 model

Note fuse 24 may be supplied directly from battery or via ignition switch

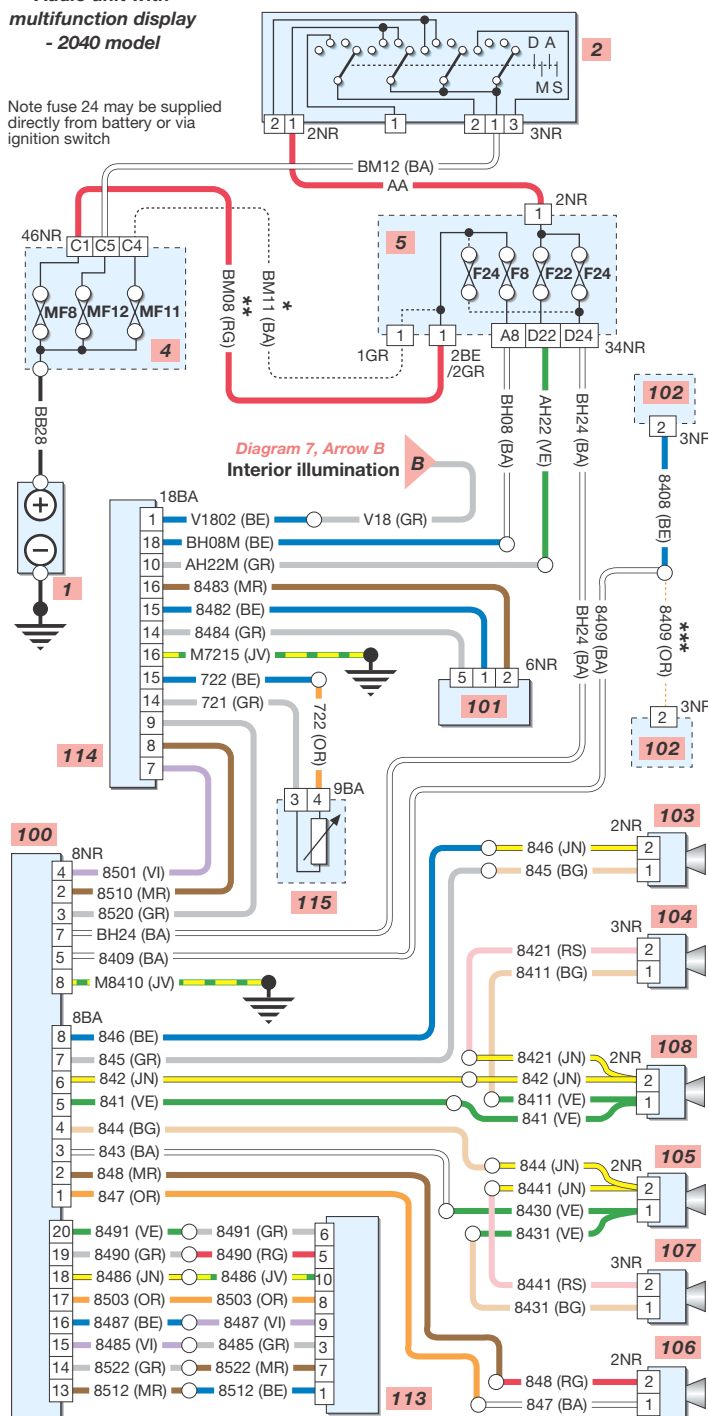

Electric front windows - models without one-touch operation

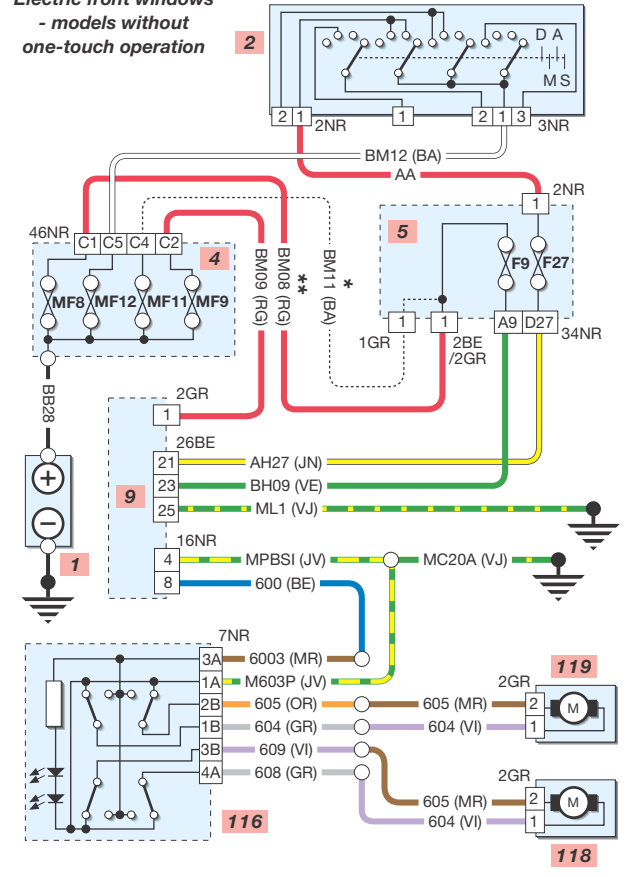

Wiring variation for driver's window with one-touch operation

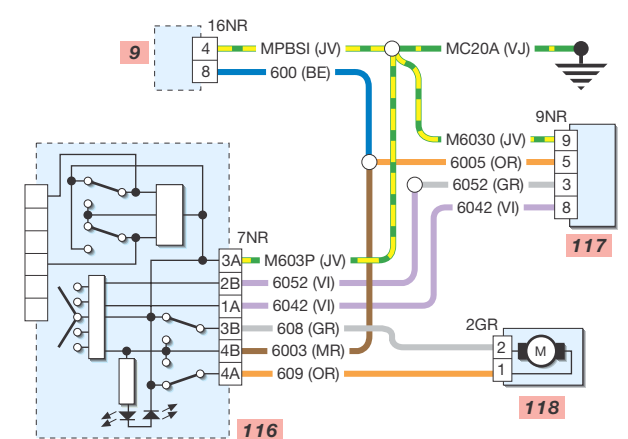

Wire colours

BA White	OR Orange
BE Blue	RG Red
BG Beige	RS Pink
GR Grey	VE Green
JN Yellow	VI Mauve
MR Brown	VJ Green/ Yellow
NR Black	

Key to items

1 Battery	116 Mirror and window control switch	132 Heated rear window
2 Ignition switch	125 Driver's mirror assembly	133 Heater panel
4 Engine fusebox	126 Rear function locking relay	
5 Passenger fusebox (28 fuse)	127 Rear window isolator switch	
6 Starter motor	128 LH rear window switch	
7 Alternator	129 LH rear window motor	
9 Built in systems interface (BSI)	130 RH rear window switch	
115 Passenger's mirror assembly	131 RH rear window motor	

Diagram 11

H32046

Rear electric windows

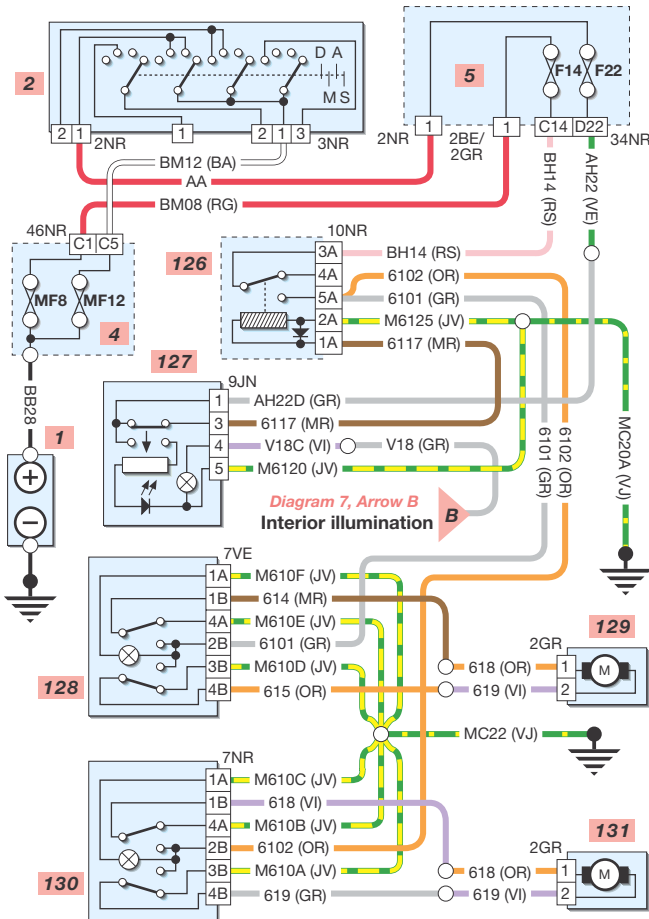
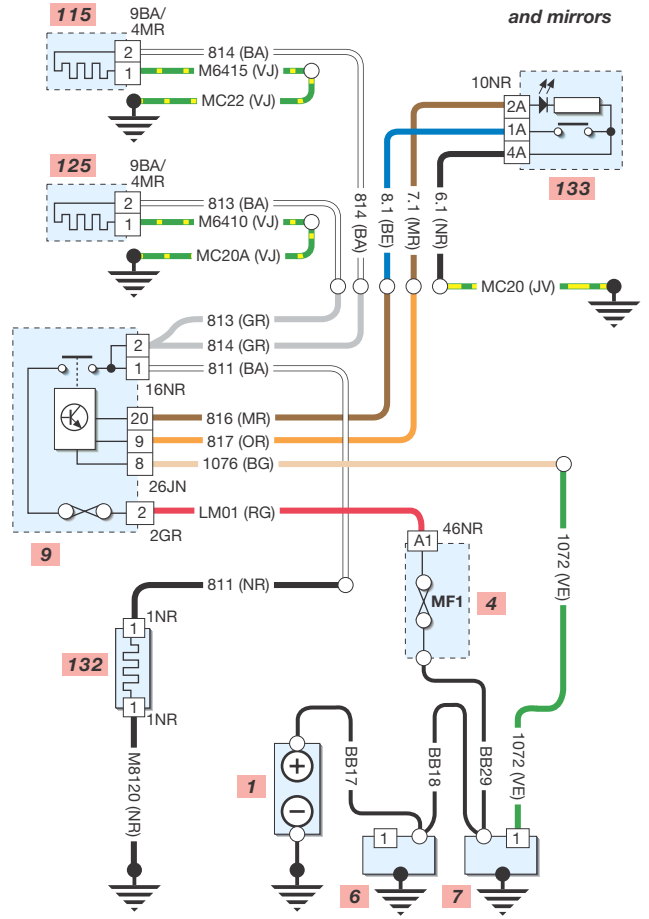
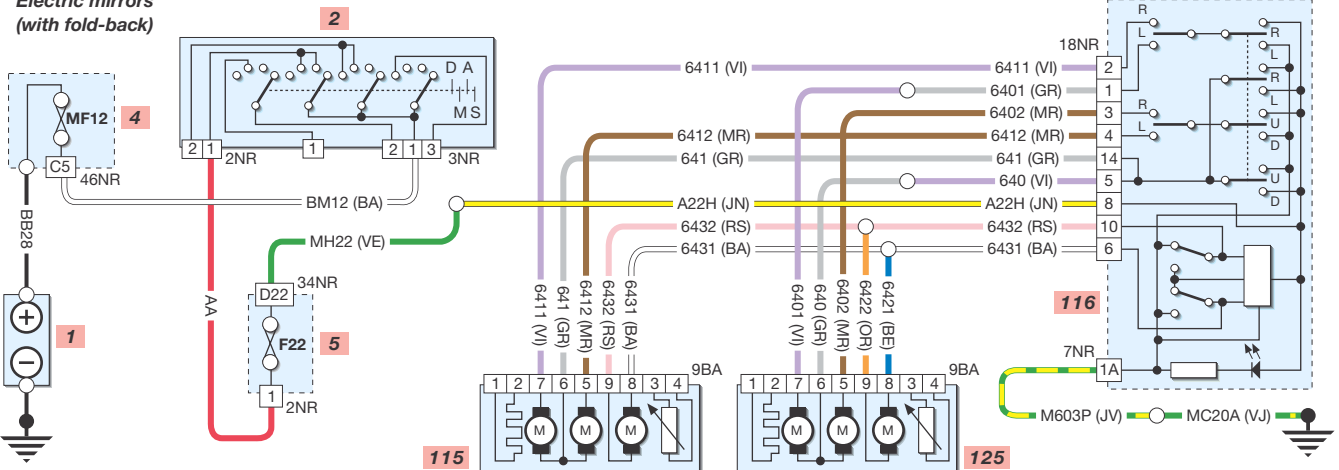

Diagram 7, Arrow B
Interior illumination

Heated rear window and mirrors



Electric mirrors (with fold-back)



Wire colours

BA White	OR Orange
BE Blue	RG Red
BG Beige	RS Pink
GR Grey	VE Green
JN Yellow	VI Mauve
MR Brown	VJ Green/ Yellow
NR Black	

Key to items

1 Battery	61 Stop light switch	139 Wash/wipe switch (continued)
2 Ignition switch	135 Rain sensor (if fitted)	d = front wiper switch
3 Instrument cluster	136 Front wiper motor	140 ABS control unit
e = control unit	137 Rear wiper motor	141 LH rear wheel sensor
w = ABS warning light	138 washer pump	142 RH rear wheel sensor
4 Engine fusebox	139 Wash/wipe switch	143 LH front wheel sensor
5 Passenger fusebox (28 fuse)	a = horn switch (not used)	144 RH front wheel sensor
8 Diagnostic connector	b = rear wiper switch	
9 Built in systems interface (BSI)	c = washer switch	

Diagram 12

H32047

Wash/wipe system

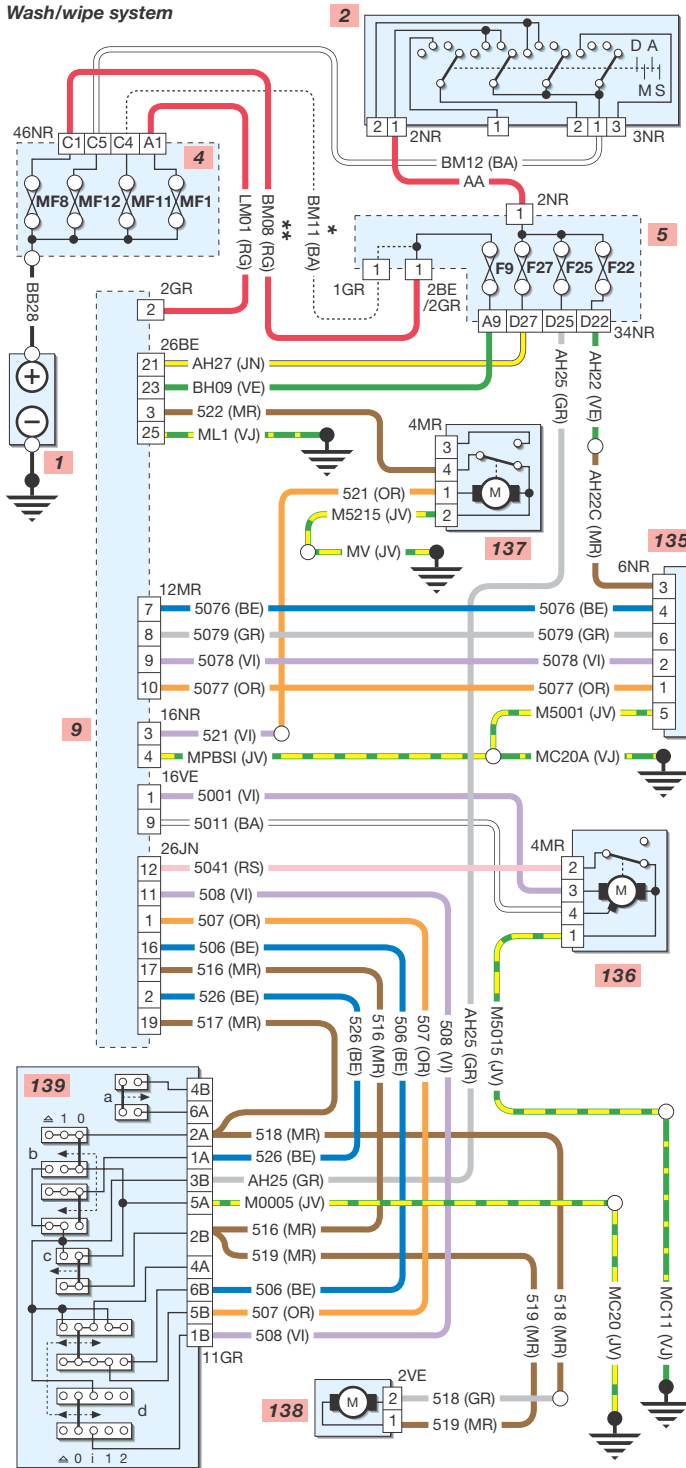

Anti-lock braking system

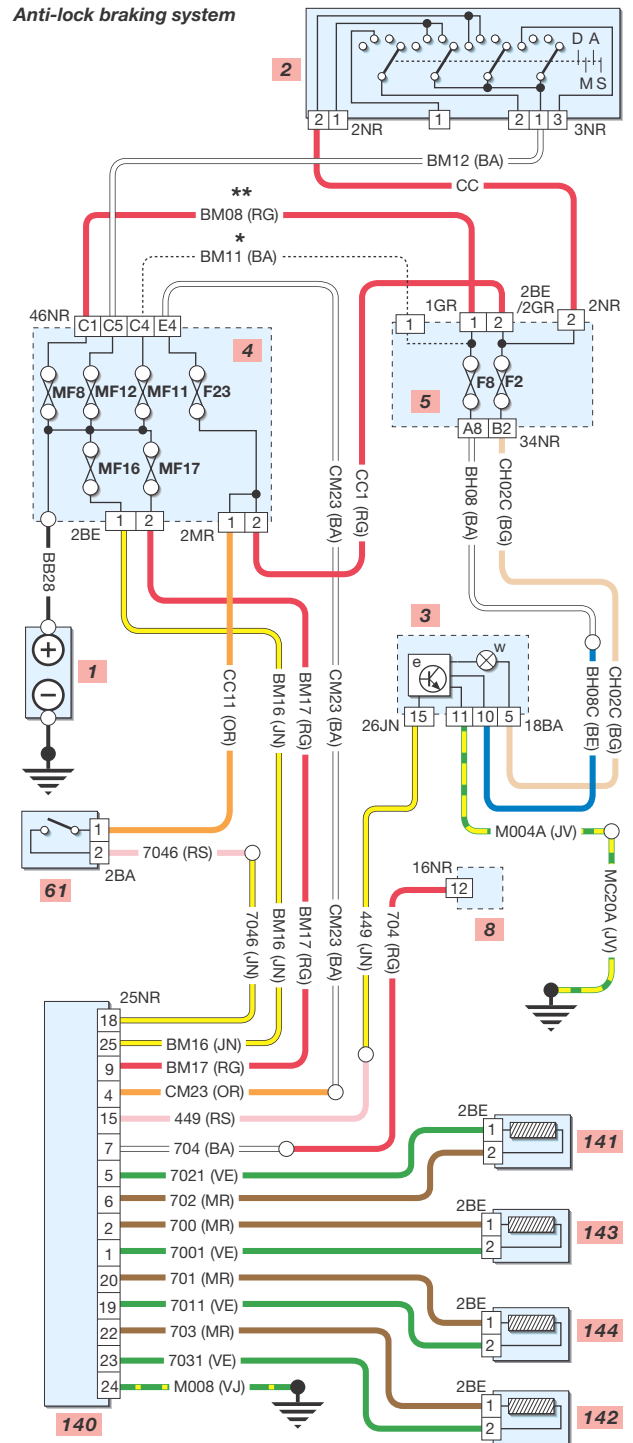

Wire colours

BA White	OR Orange
BE Blue	RG Red
BG Beige	RS Pink
GR Grey	VE Green
JN Yellow	VI Mauve
MR Brown	VJ Green/ Yellow
NR Black	

Key to items

1	Battery	150	RH rear door lock assembly
2	Ignition switch	151	Boot/tailgate lock
4	Engine fusebox		
5	Passenger fusebox (28 fuse)		
9	Built in systems interface (BSI)		
147	LH front door lock motor assembly		
148	RH front door lock motor assembly		
149	LH rear door lock assembly		

Diagram 13

- *** With rear power windows
- **** Without rear power windows
- ***** With deadlocking
- ****** Without deadlocking

H32048

Central locking

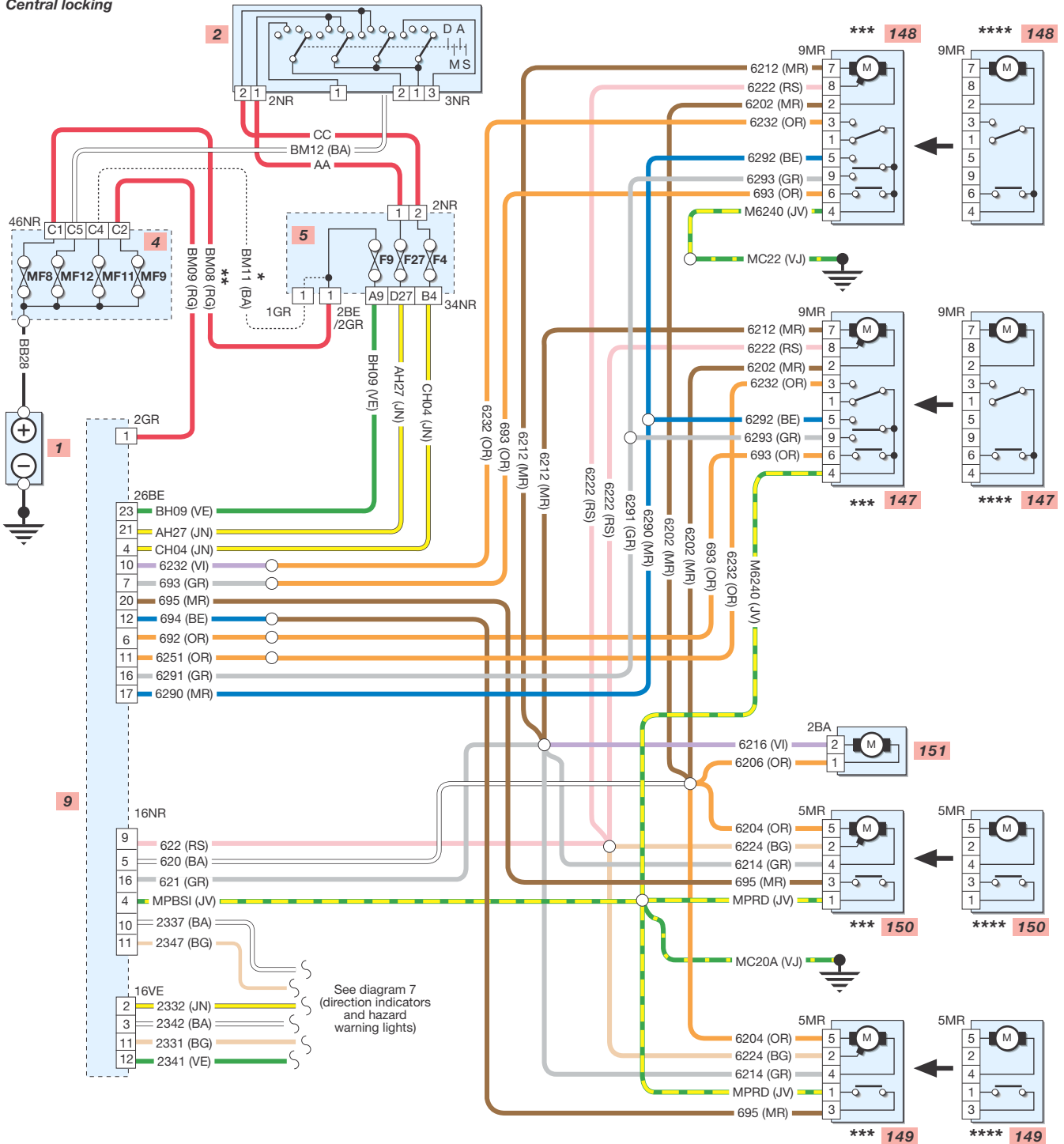

Wire colours

BA White	OR Orange
BE Blue	RG Red
BG Beige	RS Pink
GR Grey	VE Green
JN Yellow	VI Mauve
MR Brown	VJ Green/Yellow
NR Black	Yellow

Key to items

1 Battery	7 Alternator	155 Airbag control unit
2 Ignition switch	8 Diagnostic connector	156 Driver's airbag
3 Instrument cluster	13 Steering wheel rotary connector	157 Passenger's airbag
x = airbag warning light	25 Passenger fusebox (12 fuse)	158 Driver's seatbelt pretensioner
y = side airbag warning light	38 A/C coolant temp. unit	159 Passenger's seatbelt pretensioner
4 Engine fusebox	42 A/C coolant temp. thermistor	160 LH side airbag
d = engine running relay	43 Pressostat	161 RH side airbag
5 Passenger fusebox (28 fuse)	44 A/C compressor	162 LH side airbag control unit
6 Starter motor	133 Heater panel	163 RH side airbag control unit
		164 Heater blower resistor
		165 Heater blower motor
		166 Passenger's airbag disable switch
		167 Passenger compartment electronic thermostat
		168 Evaporator thermostat

Diagram 14

H32049

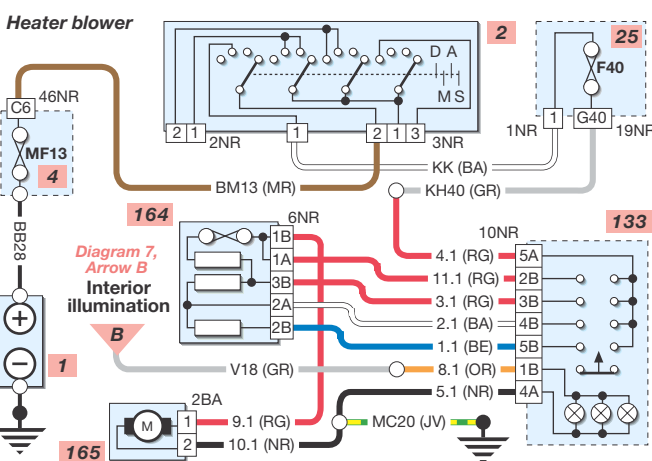
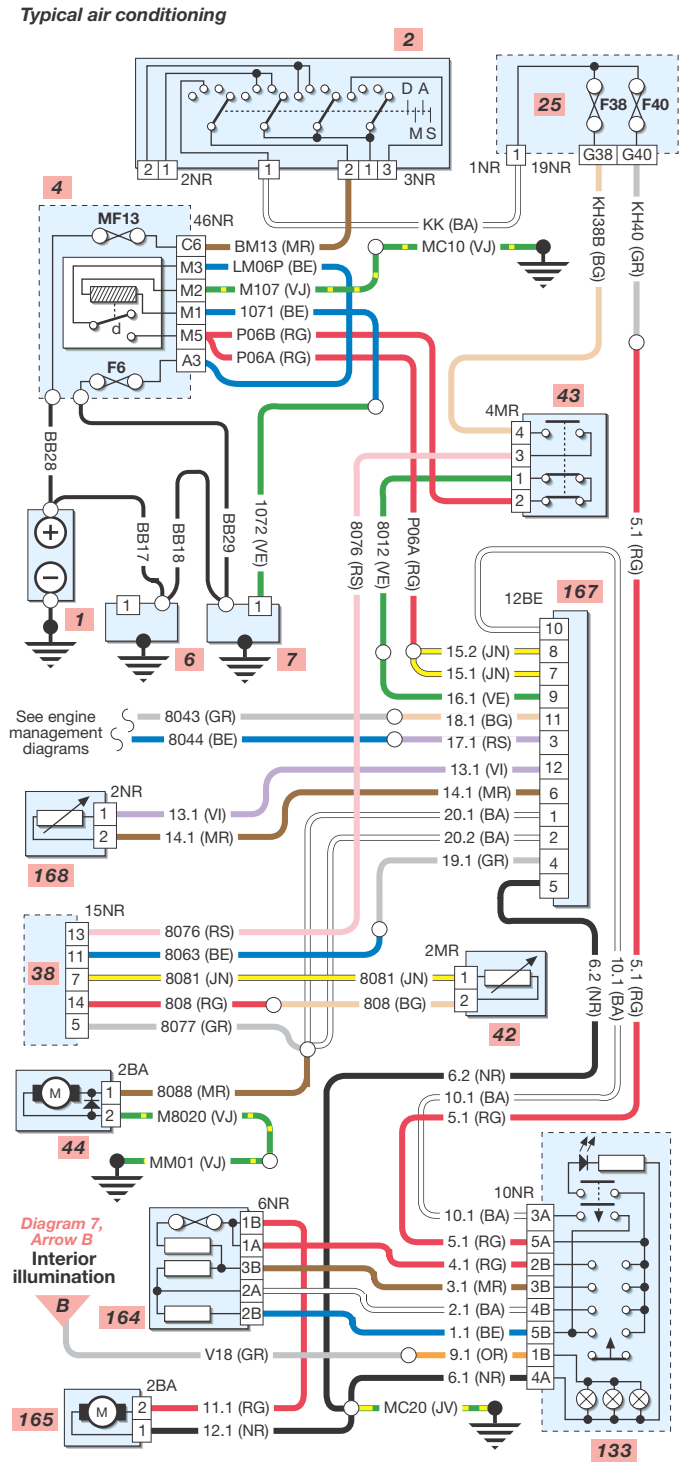
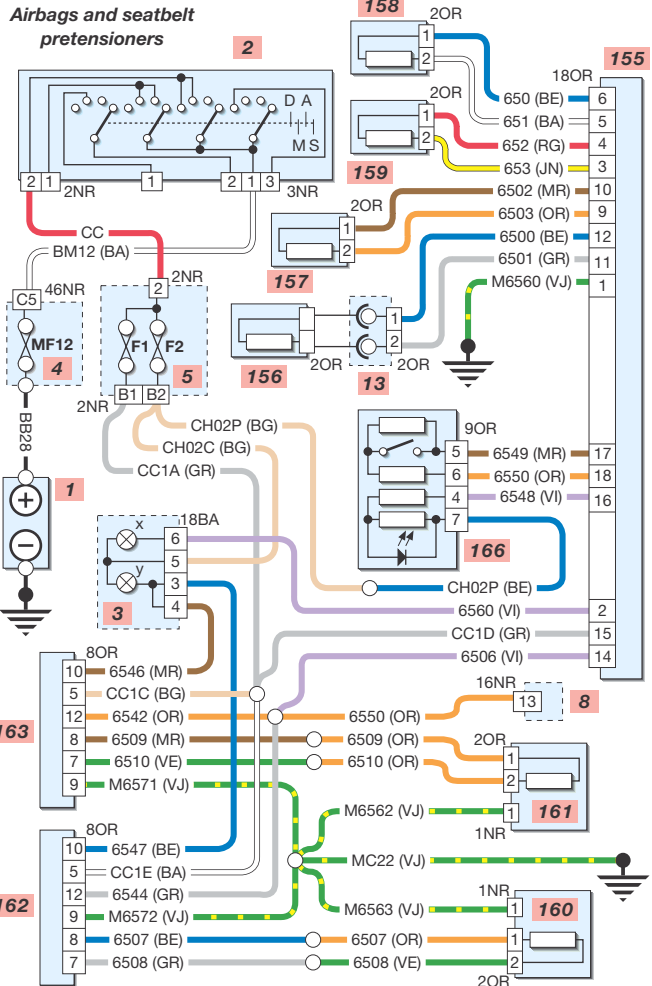

Wire colours

BA White	OR Orange
BE Blue	RG Red
BG Beige	RS Pink
GR Grey	VE Green
JN Yellow	VI Mauve
MR Brown	VJ Green/ Yellow
NR Black	

Key to items

1 Battery	5 Passenger fusebox (28 fuse)	176 Engine coolant temperature sensor
2 Ignition switch	8 Diagnostic connector	177 Cruise control clutch switch
3 Instrument cluster	33 Engine management control unit	
d = glow plug warning light	34 Double function relay	
e = control unit	172 Pressure regulator (high pressure)	
z = engine management warning light	173 3rd piston cut-out solenoid	
4 Engine fusebox	174 EGR butterfly solenoid	
d = engine running relay	175 EGR solenoid	

Diagram 15

H32050

HdI Diesel engine management system (part 1 of 2)

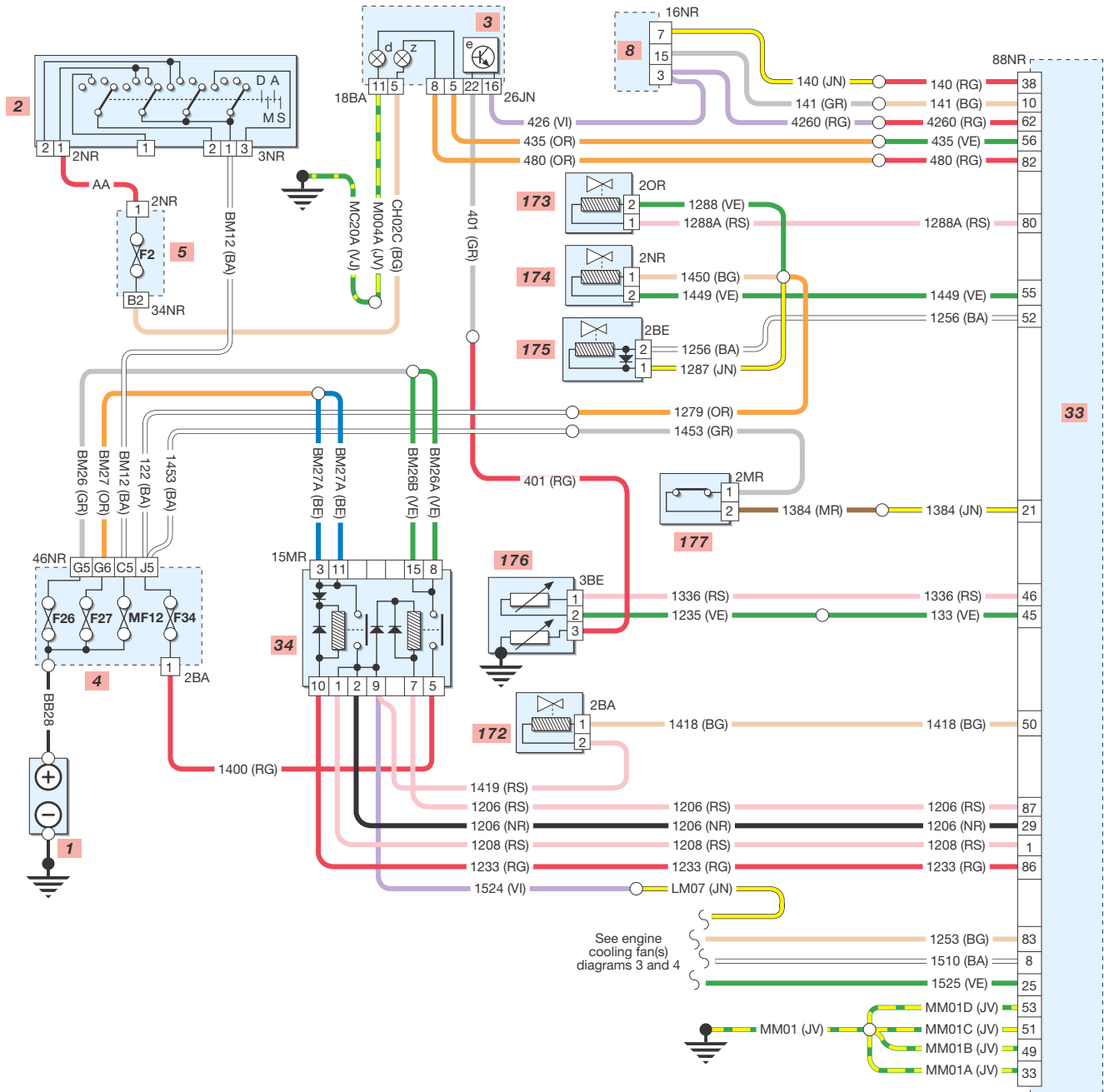

Wire colours

BA White	OR Orange
BE Blue	RG Red
BG Beige	RS Pink
GR Grey	VE Green
JN Yellow	VI Mauve
MR Brown	VJ Green/ Yellow
NR Black	

Key to items

1 Battery	180 Fuel injector	188 Accelerator pedal position sensor
2 Ignition switch	181 Cylinder reference sensor	189 Pressure sensor (high pressure)
4 Engine fusebox	182 Speed sensor	
5 Passenger fusebox (28 fuse)	183 Air flow sensor	
9 Built in systems interface (BSI)	184 Diesel thermistor	
17 Pre-heat control unit	185 Heater unit relay A	
18 Glow plugs	186 Heater unit relay B	
33 Engine management control unit	187 Additional heater	

H32051

Hdi Diesel engine management system (part 2 of 2)

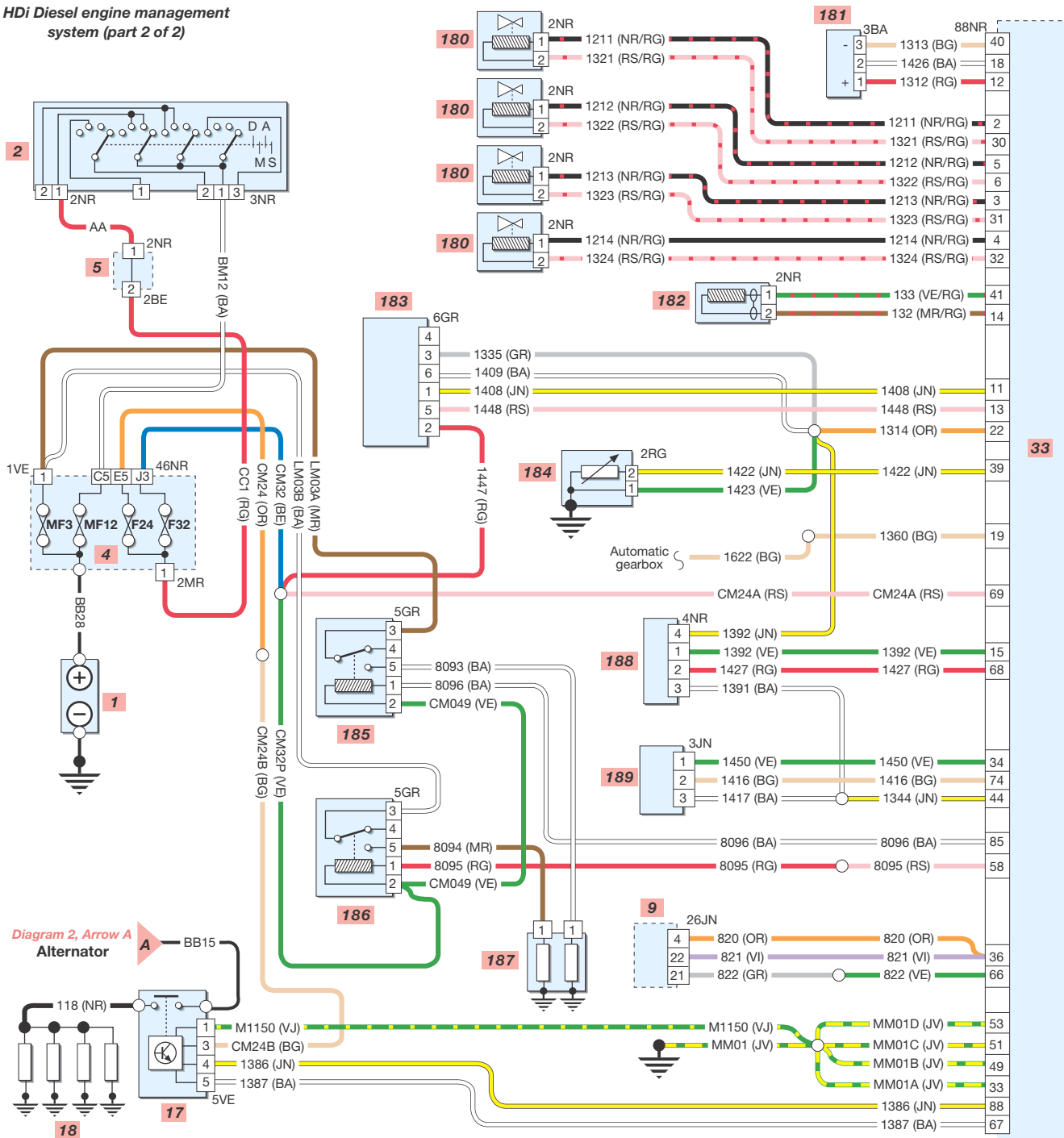

Wire colours

BA White	OR Orange
BE Blue	RG Red
BG Beige	RS Pink
GR Grey	VE Green
JN Yellow	VI Mauve
MR Brown	VJ Green/ Yellow
NR Black	

Key to items

1 Battery	9 Built in systems interface (BSI)	197 MAP sensor
2 Ignition switch	15 Speed sensor	198 Engine speed sensor
3 Instrument cluster	33 Engine management control unit	199 Fuel injector
b = speedometer	34 Double function relay	200 Power steering pressure switch
c = tachometer	52 Fuel pump/fuel gauge sender unit	201 Throttle position sensor
e = control unit	192 Oxygen sensor	202 Air temperature sensor
z = engine management warning light	193 Canister purge solenoid	203 Coolant temperature sensor
4 Engine fusebox	194 Idle stepper motor	204 Knock sensor
5 Passenger fusebox (28 fuse)	195 Ignition coil	205 Throttle heater
8 Diagnostic socket	196 Spark plugs	206 Inertia switch

Diagram 17

H32052

MM1AP fuel injection system

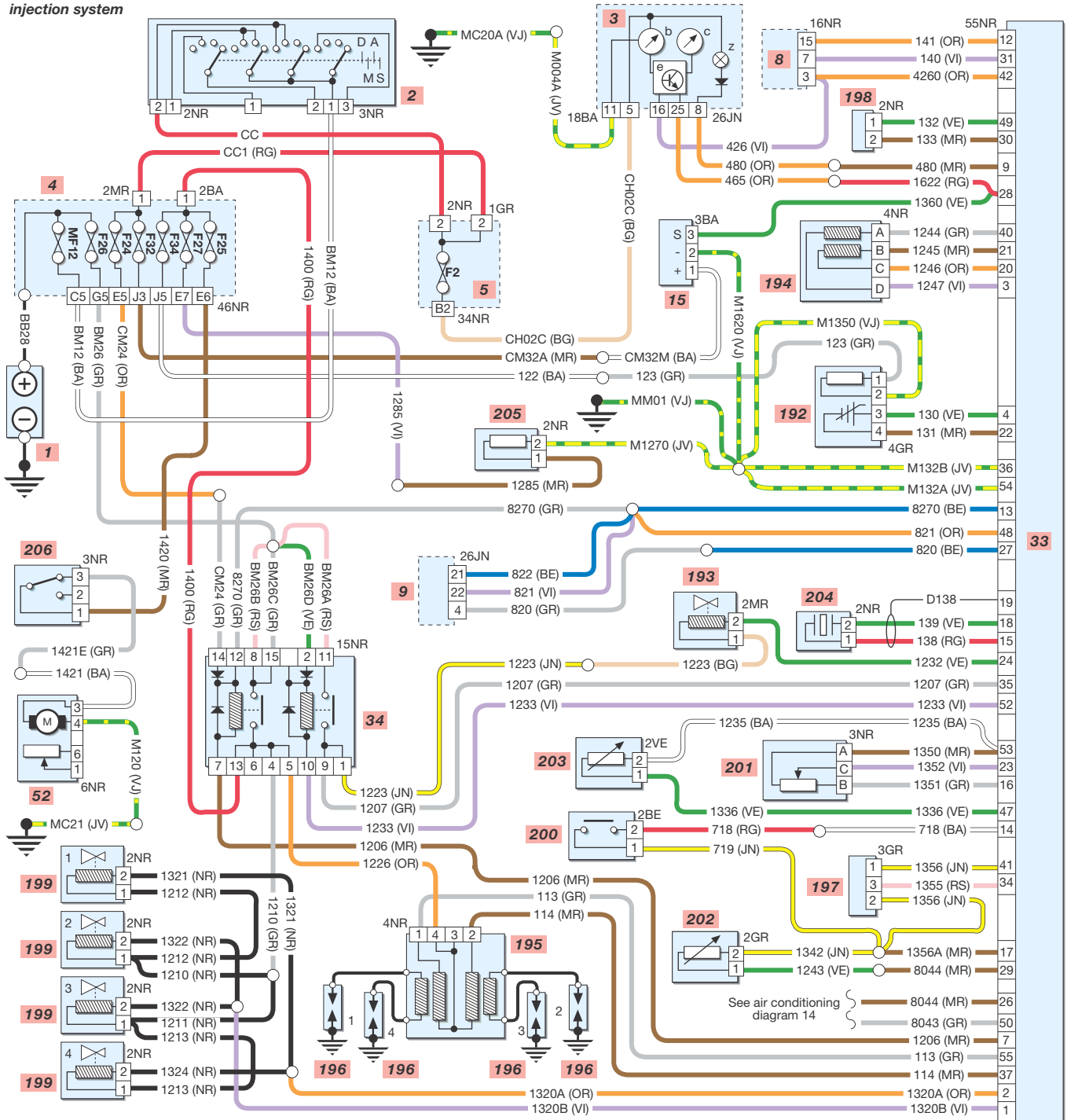

Wire colours

BA White	OR Orange
BE Blue	RG Red
BG Beige	RS Pink
GR Grey	VE Green
JN Yellow	VI Mauve
MR Brown	VJ Green/Yellow
NR Black	Yellow

Key to items

1 Battery	5 Passenger fusebox (28 fuse)	193 Canister purge solenoid	201 Throttle position sensor
2 Ignition switch	8 Diagnostic socket	194 Idle stepper motor	202 Air temperature sensor
3 Instrument cluster	9 Built in systems interface (BSI)	195 Ignition coil	203 Coolant temperature sensor
b = speedometer	15 Speed sensor	196 Spark plugs	204 Knock sensor
c = tachometer	33 Engine management control unit	197 MAP sensor	205 Throttle heater
e = control unit	34 Double function relay	198 Engine speed sensor	206 Inertia switch
z = engine man. warning light	52 Fuel pump/fuel gauge sender unit	199 Fuel injector	
4 Engine fusebox	192 Oxygen sensor	200 Power steering pressure switch	

Diagram 18

H32053

Bosch MP7.2 Motronic fuel injection system

