



**Screw Drives
Worm Gear Screw
Jacks**

04/2009

Neff screw drives

If you want to strike new paths for your customers from the fields of mechanical engineering and handling/automation technology, you need to know the well-worn paths of drive technology as well as Karl Neff does. The family-led NEFF company has been developing, manufacturing and selling screw drives and linear drives in rolled and ground quality with the highest precision for over 100 years. Consistent user-orientation, Swabian spirit of invention and non-compromising quality are combined in our products.

Following the building kit principle, NEFF produces precisely the drive that suits the individual customer application: screw drives with various trapezoidal screws and nuts, precision-rolled or precision-cut ball screw drives and worm gear screw jacks. Custom solutions from one-offs to large series too, if required. This way we save money for the customer in the right places: with short delivery times, competitive prices and a comprehensive advisory service, we are reliable partners to the manufacturers of plants, machines and apparatus.



Contents

Overview	4
Trapezoidal screws	
General technical data	6
Technical data	7
Ball screw drives	
General technical data	8
Technical data	9
Screw end machining	
Movable/fixed bearing	10
FK, FF, BK, BF	13
Bearing units	
BK, BF, FK, FF, ZKLR	14
Nuts	
Grooved nuts	17
Trapezoidal nuts	18
Flanged ball nuts	22
Cylindrical ball nuts	24
Worm Gear Screw Jacks	
General technical data	27
Dimensions, versions	29
Fixings	31
Universal joint bearings	33
Attachments	34
Spiral spring cover	36
3-phase motors	38
Motor adapter flanges	40
Couplings	42
Universal joint shafts	44
Pillow blocks	47
Examples for the arrangements and direction of rotation	48
Selection	50
Calculation	51
Drive sizing	60
Installation and maintenance	65

Overview

NEFF Screw drives

Trapezoidal screw drives

NEFF trapezoidal screws are manufactured from special semi-finished goods with high demands on straightness. The series conforms to DIN 103 and offers an extensive range of nuts made from various materials – all ready for installation. The very low backlash in the nuts allows radial forces to be absorbed.

Trapezoidal screw drives

- Precision-rolled trapezoidal screws RPTS, Ø 10–80 mm in versions with single or multi-start threads.
- Planetary-milled trapezoidal screws WPTS, Ø 16–120 mm (the trapezoidal screws can also be supplied in coated and rustproof versions).

Trapezoidal nuts

- KSM, steel nut, round, Ø 10–80 mm
- SKM, steel nut, hexagonal, Ø 10–80 mm
- LRM, red bronze nut, Ø 10–80 mm
- EFM, red bronze, ready to install, Ø 10–80 mm
- Central flanged nut, bronze GBZ 12
- Central flanged nut, plastic, PTFE alloy
- Universal joint nut, bronze GBZ 12
- Universal joint nut, plastic, PTFE alloy
- Bracket nut, bronze GBZ 12
- Bracket nut, plastic, PTFE alloy

Ball screw drives

The range conforms to DIN 69051 and the NEFF standard. All nuts (flanged and cylinder versions) can be supplied with the corresponding DIN connections. Pre-tensioned double-nut units achieve high positioning accuracies. Special nuts on enquiry. All ball screw drives are available with customer-specific end machining. On request we can supply soft-annealed ends for you to carry out your own end machining.

Ball screws

- Precision-rolled ball screw, Ø 12–63 mm
- Lead from 5–50 mm, lead accuracies of 23 µm, 50 µm and 200 µm/300 mm

Ball nuts

- KGF-N NEFF flanged single nut
- KGF-D DIN flanged single nut
- KGM-N NEFF cylinder single nut
- KGM-D DIN cylinder single nut
- KGM-E screw-in cylinder single nut
- Cut ball screw drives, Ø 6–120 mm (the ball nuts can also be supplied anti backlash and pre-tensioned in conjunction with spindles.)

Overview

NEFF Worm Gear Screw Jacks

Worm Gear Screw Jacks

The range encompasses 11 installation sizes with lifting forces from 2.5 to 500 kN, with fixed and rotating spindles.

- Some installation sizes are available as standard with lifetime lubrication
- Significantly improved efficiency through optimisation of tolerances and surface quality
- Limited absorption of lateral forces through the use of the NEFF glide screw
- Optionally also available with ball screw drives for the same installation sizes

NEFF Accessories

- Fixed and bearing units
- Comprehensive range of accessories, such as cover systems, couplings, hand wheels, drive motors, etc.



GRA
97
105
3

General technical data

Trapezoidal screws

NEFF trapezoidal screws are manufactured in a rolled execution.

Precision trapezoidal screw RPTS

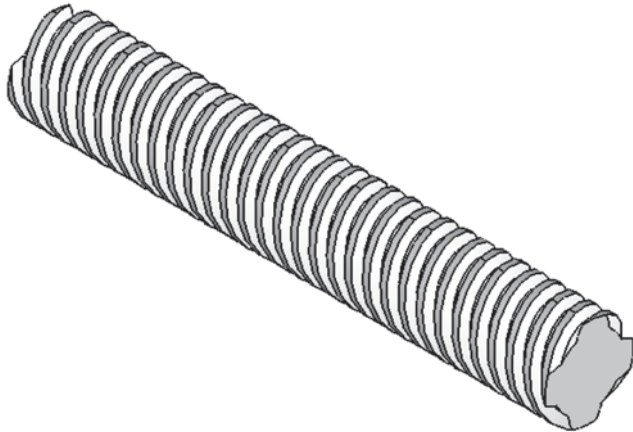

Technical data

- Thread: _____ Metric ISO trapezoidal thread to DIN 103
- Diameter: _____ 10 – 80 mm
- Lead: _____ 2 – 24 mm
- No. of starts: _____ Up to 6 starts
- Thread direction: _____ Right hand thread; single start also available left hand thread
- Length: _____ Up to 3000 mm for screws up to Tr 18 x 4
Up to 6000 mm for screws up to Tr 20 x 4
- Material: _____ 1.0401 (case hardened steel C15), stress relief annealed, weldable
- Lead accuracy: _____ 50 to 300 µm/300 mm
- Straightness: _____ 0,1 to 0,5 mm/300 mm
- Left and right hand screw: _____ For thread leads of 2 – 10 mm
- End machining: _____ To customer's specs

Trapezoidal screws RPTS

Rolled precision trapezoidal screw RPTS

Standard length 3000 mm, from Ø 20 mm up to 6000 mm available.
Dimension L to customer's specs.

Material: 1.0401 (C15).

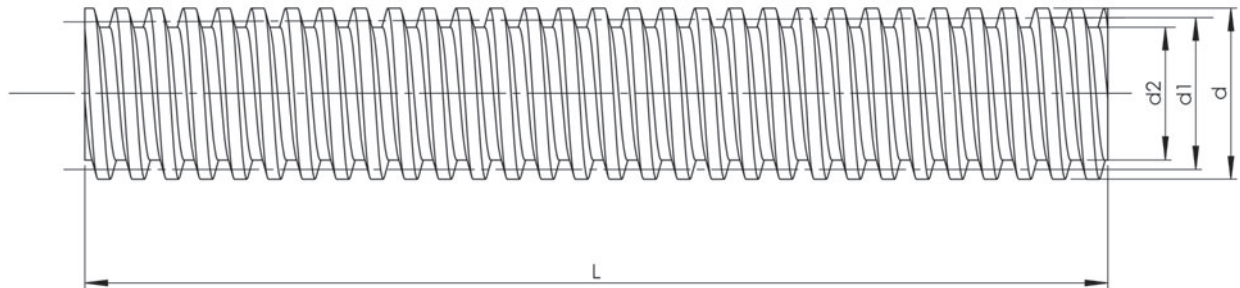

Type Outer diameter [mm] Lead [mm] Right/left hand thread	d	Dimensions [mm]				Accuracy [μm/ 300 mm]	Straight- ness [mm/ 300 mm]	α	η	Distributed load [kg/m]	Planar moment of inertia [cm ⁴]	Moment of resistance [cm ³]	Mass moment of inertia [kg m ² /m]
		d _{1 min}	d _{1 max}	d ₂	H ₁								
RPTS Tr 10x2	10	8.739	8.929	6.89	1	300	0.5	4° 2'	0.40	0.500	0.011	0.032	0.51 · 10 ⁻⁵
RPTS Tr 10x3		8.191	8.415	5.84	1.5	300	0.5	6° 24'	0.51	0.446	0.0057	0.020	0.40 · 10 ⁻⁵
RPTS Tr 12x3	12	10.191	10.415	7.84	1.5	300	0.5	5° 11'	0.46	0.68	0.019	0.047	0.94 · 10 ⁻⁵
RPTS Tr 12x6 P3	12	10.165	10.415	7.84	1.5	300	0.5	10° 18'	0.62	0.68	0.019	0.047	0.94 · 10 ⁻⁵
RPTS Tr 14x3	14	12.191	12.415	9.84	1.5	300	0.5	4° 22'	0.42	0.96	0.046	0.094	1.88 · 10 ⁻⁵
RPTS Tr 14x4		11.640	11.905	8.80	2	300	0.5	6° 3'	0.50	0.888	0.029	0.067	1.60 · 10 ⁻⁵
RPTS Tr 16x2	16	14.729	14.929	12.89	1	50	0.1	2° 36'	0.28	1.39	1.36	0.21	3.9 · 10 ⁻⁵
RPTS Tr 16x4	16	13.640	13.905	10.80	2	50	0.1	5° 11'	0.46	1.21	0.067	0.124	2.96 · 10 ⁻⁵
RPTS Tr 16x8 P4	16	13.608	13.905	10.80	2	300	0.3	10° 18'	0.62	1.21	0.067	0.124	2.96 · 10 ⁻⁵
RPTS Tr 18x4	18	15.640	15.905	12.80	2	50	0.1	4° 32'	0.43	1.58	0.132	0.206	5.05 · 10 ⁻⁵
RPTS Tr 20x4	20	17.640	17.905	14.80	2	50	0.1	4° 2'	0.40	2.00	0.236	0.318	8.10 · 10 ⁻⁵
RPTS Tr 20x8 P4		17.608	17.905	14.80	2	200	0.2	8° 3'	0.57	2.00	0.236	0.318	8.10 · 10 ⁻⁵
RPTS Tr 20x16 P4		17.608	17.905	14.80	2	200	0.2	15° 47'	0.71	2.00	0.236	0.318	8.10 · 10 ⁻⁵
RPTS Tr 22x5	22	19.114	19.394	15.50	2.5	50	0.1	4° 39'	0.43	2.34	0.283	0.366	1.11 · 10 ⁻⁴
RPTS Tr 22x24 P4 S		19.140	19.505	16.50	2.5	200	0.2	21° 34'	0.75	2.34	0.364	0.441	1.11 · 10 ⁻⁴
RPTS Tr 24x5	24	21.094	21.394	17.50	2.5	50	0.1	4° 14'	0.41	2.85	0.460	0.526	1.65 · 10 ⁻⁴
RPTS Tr 24x10 P5		21.058	21.394	17.50	2.5	200	0.2	8° 25'	0.58	2.85	0.460	0.526	1.65 · 10 ⁻⁴
RPTS Tr 26x5	26	23.094	23.394	19.50	2.5	50	0.1	3° 52'	0.39	3.40	0.710	0.728	2.35 · 10 ⁻⁴
RPTS Tr 28x5	28	25.094	25.394	21.50	2.5	50	0.1	3° 34'	0.37	4.01	1.050	0.976	3.26 · 10 ⁻⁴
RPTS Tr 30x6	30	26.547	26.882	21.90	3	50	0.1	4° 2'	0.40	4.50	1.130	1.030	4.10 · 10 ⁻⁴
RPTS Tr 30x12 P6		26.507	26.882	21.90	3	200	0.2	8° 3'	0.57	4.50	1.130	1.030	4.10 · 10 ⁻⁴
RPTS Tr 32x6	32	28.547	28.882	23.90	3	50	0.1	3° 46'	0.38	5.19	1.600	1.340	5.45 · 10 ⁻⁴
RPTS Tr 36x6	36	32.547	32.882	27.90	3	50	0.1	3° 18'	0.35	6.71	2.970	2.130	9.10 · 10 ⁻⁴
RPTS Tr 40x7	40	36.020	36.375	30.50	3.5	50	0.1	3° 29'	0.37	8.21	4.250	2.790	1.37 · 10 ⁻³
RPTS Tr 40x14 P7		35.978	36.375	30.50	3.5	200	0.2	6° 57'	0.53	8.21	4.250	2.790	1.37 · 10 ⁻³
RPTS Tr 44x7	44	40.020	40.275	34.50	3.5	50	0.1	3° 8'	0.34	10.10	6.950	4.030	2.10 · 10 ⁻³
RPTS Tr 48x8	48	43.468	43.868	37.80	4	100	0.1	3° 18'	0.35	12.00	10.000	5.300	2.90 · 10 ⁻³
RPTS Tr 50x8	50	45.468	45.868	39.30	4	100	0.1	3° 10'	0.34	13.10	11.700	5.960	3.40 · 10 ⁻³
RPTS Tr 60x9	60	54.935	55.360	48.15	4.5	200	0.3	2° 57'	0.33	19.00	26.400	11.000	7.30 · 10 ⁻³
RPTS Tr 70x10	70	64.425	64.850	57.00	5	200	0.3	2° 48'	0.32	26.00	51.800	18.200	1.40 · 10 ⁻²
RPTS Tr 80x10	80	74.425	74.850	67.00	5	200	0.3	2° 25'	0.29	34.70	98.900	29.500	2.40 · 10 ⁻²

General technical data

Ball screws

Manufacturing process

The thread profile of NEFF ball screws is produced by cold rolling in the thread rolling method. Both screw and nut have a gothic thread profile. The load angle is 45°.

Linear speeds

At present, the permissible rotation limit is in the region of 3000 rpm, when individual dimensions to 4500 rpm. This limit defines the maximum rotation, which must be run only under ideal operating conditions.

Installed position

The position in which the screw drive is installed can always be freely chosen. Please consider that all radial forces that occur need to be absorbed by external guides.

Class of accuracy of the screws

P3 = Lead accuracy 12 µm/300 mm
P5 = Lead accuracy 23 µm/300 mm
T7 = Lead accuracy 52 µm/300 mm
T9 = Lead accuracy 130 µm/300 mm
T10 = Lead accuracy 200 µm/300 mm
If no specs we deliver class T7.

Self-locking

Ball screw drives are generally not self-locking due to the low friction. It is therefore advisable to install suitable motors with holding brake, particularly when the ball screw drive is installed vertically.

Efficiency

Trapezoidal screw drives have a max. mechanical efficiency of 50 %, ball screw drives achieve a mechanical efficiency of up to 98 %.

Duty cycle

The ball screw drive permits a duty cycle of up to 100 %. Extremely high forces in combination with high duty cycles can reduce the life time.

Temperatures

All screw drives are designed for continuous operation at ambient temperatures of -30 °C up to 80 °C. Temperatures of up to 110 °C are also permitted for brief periods. Ball screw drives are only in exceptional cases suitable for operation at subzero temperatures.

Repeatability

The repeatability is defined as the capability of a screw drive to reach an actual position that has once been reached again under the same conditions. It refers to the average position variation according to VDI/DGQ 3441. The repeatability is influenced amongst others by:

- Load
- Speed
- Deceleration
- Direction of travel
- Temperature

Aggressive ambient working conditions

In cases of heavy dirt and dust particles, an additional bellow or a spiral spring cover is recommended.

Technical Data _____ Ball screw KGS

- Thread: _____ Gothic profile (pointed profile)
- Diameter: _____ Standard: 12 – 63 mm
- Lead: _____ Standard: 5 – 50 mm
- Number of starts: _____ 1 – 5
- Thread direction: _____ Right hand thread,
KGS 2005 + 3205 also left
hand thread
- Length: _____ Standard: 5600 mm
KGS 1205: 2000 mm
- Material: _____ 1.1213 (Cf 53)
Ball track inductively hardened
and polished, soft-annealed
screw end and core
- Straightness: _____ L < 500 mm: 0.05 mm/m
L = 500 – 1000 mm: 0.08 mm/m
L > 1000 mm: 0.1 mm/m
- Left and right hand screw: _____ KGS 2005 + 3205 only
- End machining: _____ To customer specs

Ball screws KGS

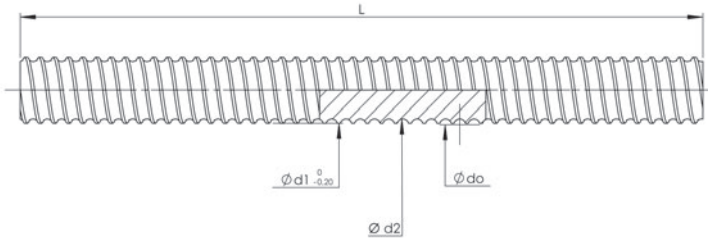
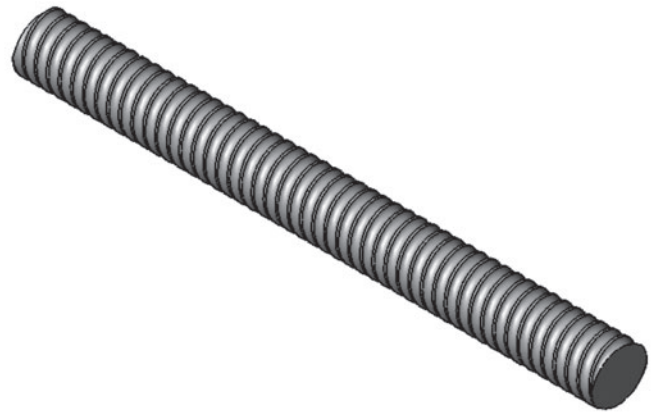

Type Diameter [mm] Lead [mm] Right hand thread	Accuracy class [μm/300 mm]	Dimensions [mm]				Distributed load W_{KGS} [kg/m]	Planar moment of inertia I_y [10 ⁴ mm ⁴]	Moment of resistance [10 ³ mm ³]	Mass moment of inertia [kg m ² /m]
		d_0	d_1	d_2	L max.				
KGS-1205	50	12	11.5	10.1	2000	0.75	0.051	0.101	$1.13 \cdot 10^{-5}$
KGS-1605	50	16	15.5	12.9	5600	1.26	0.136	0.211	$3.21 \cdot 10^{-5}$
KGS-1610	50	16	15.4	13.0	5600	1.26	0.140	0.216	$3.21 \cdot 10^{-5}$
KGS-2005	50	20	19.5	16.9	5600	2.04	0.400	0.474	$8.46 \cdot 10^{-5}$
KGS-2020	50	20	19.5	16.9	5600	2.04	0.400	0.474	$8.46 \cdot 10^{-5}$
KGS-2050	50	20	19.1	16.5	5600	2.04	0.364	0.441	$8.46 \cdot 10^{-5}$
KGS-2505	50	25	24.5	21.9	5600	3.33	1.129	1.031	$2.25 \cdot 10^{-4}$
KGS-2510	50	25	24.5	21.9	5600	3.33	1.129	1.031	$2.25 \cdot 10^{-4}$
KGS-2520	50	25	24.6	22.0	5600	3.33	1.150	1.045	$2.25 \cdot 10^{-4}$
KGS-2525	50	25	24.5	22.0	5600	3.33	1.150	1.045	$2.25 \cdot 10^{-4}$
KGS-2550	50	25	24.1	21.5	5600	3.33	1.049	0.976	$2.25 \cdot 10^{-4}$
KGS-3205	50	32	31.5	28.9	5600	5.63	3.424	2.370	$6.43 \cdot 10^{-4}$
KGS-3210	50	32	32.7	27.3	5600	5.63	2.727	1.998	$6.43 \cdot 10^{-4}$
KGS-3220	50	32	31.7	27.9	5600	5.63	2.974	2.132	$6.43 \cdot 10^{-4}$
KGS-3240	50	32	30.9	28.3	5600	5.63	3.149	2.225	$6.43 \cdot 10^{-4}$
KGS-4005	50	40	39.5	36.9	5600	9.01	9.101	4.933	$1.65 \cdot 10^{-3}$
KGS-4010	50	40	39.5	34.1	5600	8.35	6.737	3.893	$1.41 \cdot 10^{-3}$
KGS-4020	50	40	39.7	35.9	5600	9.01	8.154	4.542	$1.65 \cdot 10^{-3}$
KGS-4040	50	40	38.9	36.3	5600	9.01	8.523	4.696	$1.65 \cdot 10^{-3}$
KGS-5010	50	50	49.5	44.1	5600	13.50	18.566	8.420	$3.70 \cdot 10^{-3}$
KGS-5020	50	50	49.5	44.1	5600	13.50	18.566	8.420	$3.70 \cdot 10^{-3}$
KGS-6310	50	63	62.5	57.1	5600	22.03	52.181	18.280	$9.84 \cdot 10^{-3}$
Left hand thread									
KGS-2005 LH	50	20	19.5	16.9	5600	2.04	0.400	0.474	$8.46 \cdot 10^{-5}$

Screw end machining for movable/ fixed bearing Form D, F

The type of bearing influences the stiffness of the entire screw drive, and also the vibration and buckling behaviour of the screw. The end machining is carried out on the ball screw as necessary for the various types of bearing.

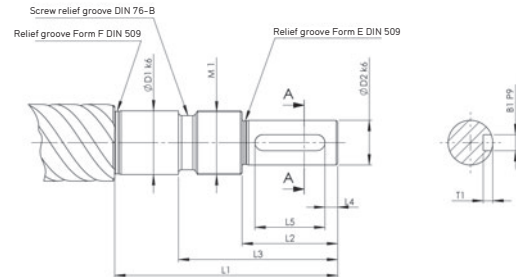

Form D TGS/GGS/KGS	Dimensions [mm]									Bearing ZKLf...ZRS
	D ₁	D ₂	L ₁	L ₂	L ₃	L ₄	L ₅	M ₁	B ₁ xT ₁	
Thread core diameter d ₂ > d ₁	12	9	55	20	32	2.5	16	M 12x1	3x1.8	1255
	15	11	58	23	35	3.5	16	M 15x1	4x2.5	1560
	20	14	70	30	44	4	22	M 20x1	5x3	2068
	25	19	82	40	57	6	28	M 25x1.5	6x3.5	2575
	30	24	92	50	67	7	36	M 30x1.5	8x4	3080

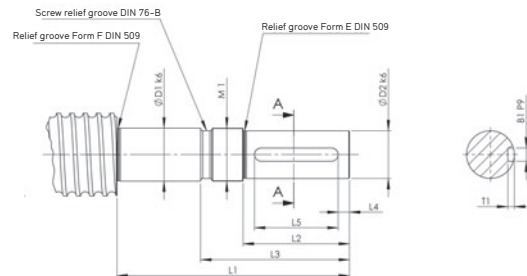

Form F TGS/GGS/KGS	Dimensions [mm]									Bearing ZARN...LTN
	D ₁	D ₂	L ₁	L ₂	L ₃	L ₄	L ₅	M ₁	B ₁ xT ₁	
Thread core diameter d ₂ > d ₁	15	11	73	23	35	3.5	16	M 15x1	4x2.5	1545
	20	14	88	30	45	4	22	M 20x1	5x3	2052
	20	14	107	30	50	4	22	M 20x1	5x3	2062
	25	19	105	40	58	6	28	M 25x1.5	6x3.5	2557
	25	19	120	40	63	6	28	M 25x1.5	6x3.5	2572
	35	28	145	60	82	10	40	M 35x1.5	8x4	3585
	40	36	175	80	103	8.5	63	M 40x1.5	10x5	4090

Screw end machining for movable/ fixed bearing Form H, J, L, A

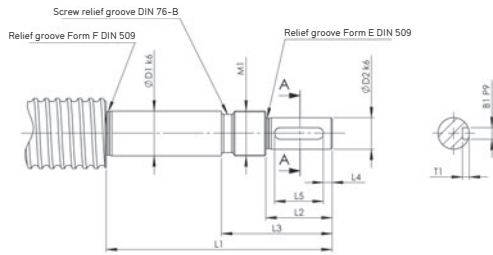

Form H TGS/GGS/KGS	Dimensions [mm]									Bearing ZARF...LTN
	D ₁	D ₂	L ₁	L ₂	L ₃	L ₄	L ₅	M ₁	B ₁ xT ₁	
Thread core diameter $d_2 > d_1$	15	11	85	23	35	3.5	16	M 15x1	4x2.5	1560
	20	14	102	30	44	4	22	M 20x1	5x3	2068
	20	14	122	30	49	4	22	M 20x1	5x3	2080
	25	19	120	40	57	6	28	M 25x1.5	6x3.5	2575
	25	19	135	40	63	6	28	M 25x1.5	6x3.5	2590
	35	28	160	60	81	10	40	M 35x1.5	8x4	35110
40	36	195	80	105	8.5	63	M 40x1.5	10x5	40115	

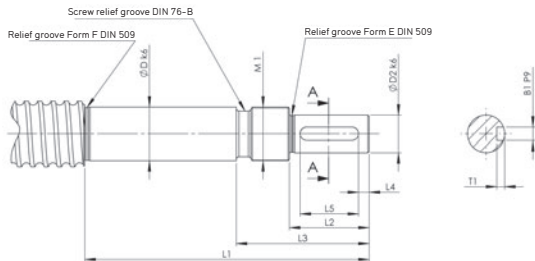

Form J TGS/GGS/KGS	Dimensions [mm]									Bearing FDX
	D ₁	D ₂	L ₁	L ₂	L ₃	L ₄	L ₅	M ₁	B ₁ xT ₁	
Thread core diameter $d_2 > d_1$	12	9	88	20	32	2.5	16	M 12x1	3x1.8	12
	15	11	92	23	35	3.5	16	M 15x1	4x2.5	15
	20	14	107	30	44	4	22	M 20x1	5x3	20
	25	19	122	40	57	6	28	M 25x1.5	6x3.5	25
	30	24	136	50	72	7	36	M 30x1.5	8x4	30
	40	36	182	80	102	8.5	63	M 40x1.5	10x5	40

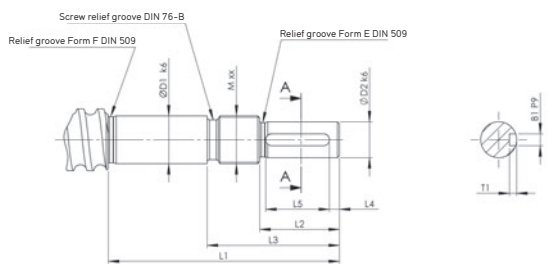

Form L TGS/GGS/KGS	Dimensions [mm]									Bearing
	D ₁	D ₂	L ₁	L ₂	L ₃	L ₄	L ₅	M ₁	B ₁ xT ₁	
Thread core diameter $d_2 > d_1$	12	9	58	20	30	2.5	16	M 12x1	3x1.8	7201 BE RS
	15	11	73	23	33	3.5	16	M 15x1	4x2.5	7202 BE RS
	20	14	88	30	43	4	22	M 20x1	5x3	7204 BE RS
	25	19	120	40	55	6	28	M 25x1.5	6x3.5	7205 BE RS
	35	28	145	60	77	10	40	M 35x1.5	8x4	7207 BE RS
	40	36	175	80	103	8.5	63	M 40x1.5	10x5	7208 BE RS

Form A

Chamfer 2 x 45°: KGS from Ø 12 – 25 mm

Chamfer 3 x 45°: KGS from Ø 26 – 40 mm

Chamfer 4 x 45°: KGS from Ø 44 – 50 mm

Screw end machining for movable/ fixed bearing Form S-W

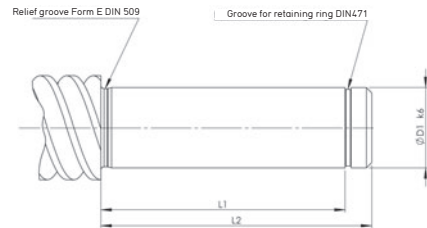

Form S TGS/GGS/KGS	Dimensions [mm]			Spacer sleeve	Bearing
	D ₁	L ₁	L ₂		
Thread core diameter d ₂ > d ₁	12	40	45	18x12.1x24	6001 RS
	15	46	51	21x15.1x28	6002 RS
	20	53	58	27x20.1x29	6004 RS
	25	53	58	32x25.1x23	6205 RS
	30	60	68	40x30.1x28	6206 RS
	40	80	88	50x40.1x44	6208 RS
	55	102	110	65x55.1x60	6211 RS

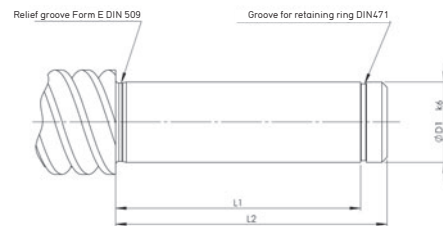

Form T TGS/GGS/KGS	Dimensions [mm]			Inner ring	Roller bearing
	D ₁	L ₁	L ₂		
Thread core diameter d ₂ > d ₁	12	40	45	2 IR 12x16x20	HK 1614 RS
	15	46	51	2 IR 15x20x23	HK 2018 RS
	20	53	58	2 LR 20x25x26.5	HK 2518 RS
	25	53	58	2 LR 25x30x26.5	HK 3018 RS
	30	60	68	2 LR 30x35x30	HK 3518 RS
	40	80	88	4 LR 40x45x20	HK 4518 RS

Form G: Screw end annealed to customer's specification.

Form K: Produced specially to customer's drawing.

Form W TGS/GGS/KGS	Dimensions [mm]			Bearing
	D ₁	L ₁	L ₂	
Thread core diameter d ₂ > d ₁	12	8	12	6001 RS
	15	9	13	6002 RS
	20	12	16	6004 RS
	25	15	20	6205 RS
	30	16	21	6206 RS
	40	18	25	6208 RS
	55	21	29	6211 RS

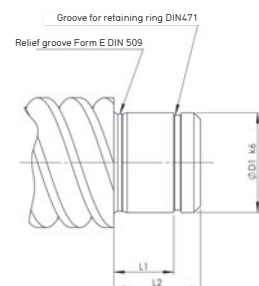

Screw end machining

Form FK - FF - BK - BF

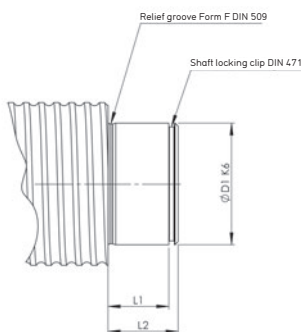
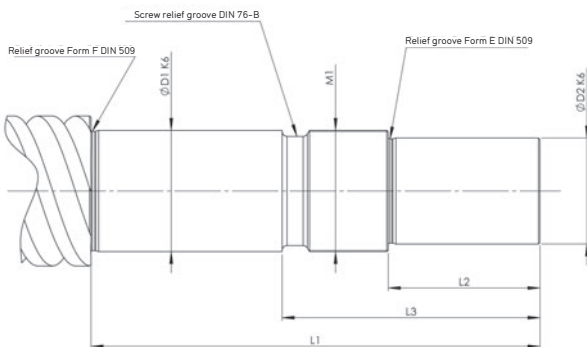
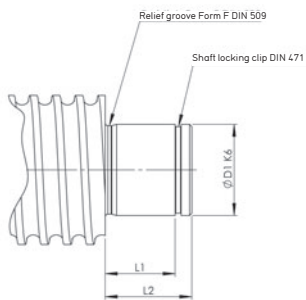
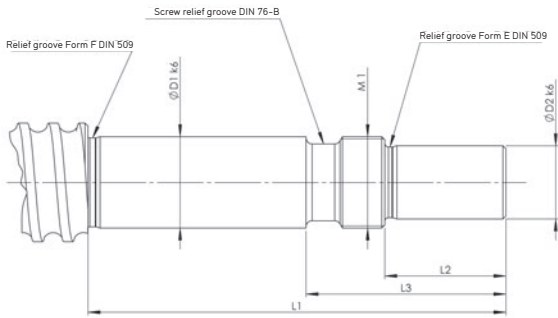

Type	$\varnothing D_{1 k6}$	$\varnothing D_{2 k6}$	L_1	L_2	L_3	M1
FK 8	8	6	44	10	20	M8x1
FK 10	10	8	51	15	26	M10x1
FK 12	12	10	51	15	26	M12x1
FK 15	15	12	61	20	36	M15x1
FK 20	20	17	27	25	49	M20x1
FK 25	25	20	106	36	59	M25x1.5
FK 30	30	25	110	42	63	M30x1.5

Type	$\varnothing D_{1 k6}$	L_2	L_1
FF 10	8	10	7
FF 12	10	11	8
FF 15	15	13	9
FF 20	20	19	14
FF 25	25	20	15
FF 30	30	21	16

Type	$\varnothing D_{1 k6}$	$\varnothing D_{2 k6}$	L_1	L_2	L_3	M1
BK 10	10	8	54	15	29	M10x1
BK 12	12	10	54	15	29	M12x1
BK 15	15	12	60	20	32	M15x1
BK 17	17	15	76	23	40	M17x1
BK 20	20	17	78	25	40	M20x1
BK 25	25	20	95	30	48	M25x1.5
BK 30	30	25	110	38	63	M30x1.5
BK 35	35	30	128	45	73	M35x1.5
BK 40	40	35	148	50	85	M40x1.5

Type	$\varnothing D_{1 k6}$	L_2	L_1
BF 10	8	10	7
BF 12	10	11	8
BF 15	15	13	9
BF 17	17	16	12
BF 20	20	19	14
BF 25	25	20	15
BF 30	30	21	16
BF 35	35	22	17
BF 40	40	23	18

Bearing units

Fixed bearing units

BK

This fixed bearing unit is a pedestal bearing with pre-tensioned axial inclined ball bearings with seals.

The fixed bearing unit is comprised of a burnished steel bearing case with 2 axial inclined ball bearings pre-tensioned by means of a flange, 2 seals with circlips and a securable DRS grooved nut. (Square nuts are used for the smaller sizes).

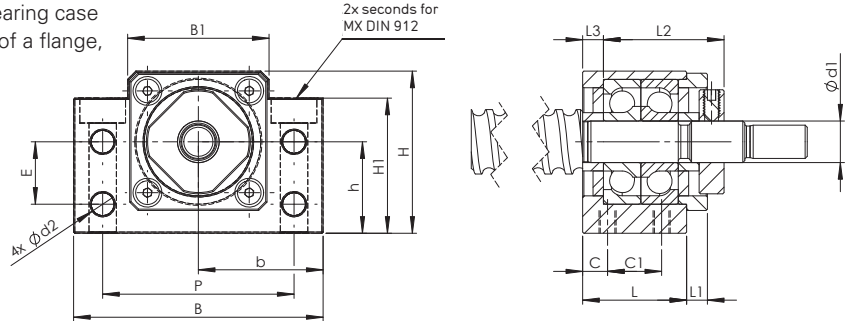
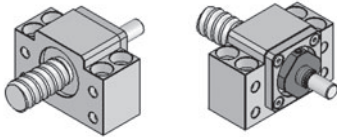

Size	Ø d ₁	L	L ₁	L ₂	L ₃	C ₁	C ₂	B	H	b	h	B ₁	H ₁	E	P	Ø d ₂	M _x
BK 10	10	25	5	29	5	13	6	60	39	30	22	34	32.5	15	46	5.5	6
BK 12	12	25	5	29	5	13	6	60	43	30	25	35	32.5	18	46	5.5	6
BK 15	15	27	6	32	6	15	6	70	48	35	28	40	38	18	54	5.5	6
BK 17	17	35	9	44	7	19	8	86	64	43	39	50	55	28	68	6.6	8
BK 20	20	35	8	43	8	19	8	88	60	44	34	52	50	22	70	6.6	8
BK 25	25	42	12	54	9	22	10	106	80	53	48	64	70	33	85	9	10
BK 30	30	45	14	61	9	22	11	128	89	64	51	76	78	33	102	11	10
BK 35	35	50	14	67	12	26	12	140	96	70	52	88	79	35	114	11	12
BK 40	40	61	18	76	15	33	14	160	110	80	60	100	90	37	130	14	16

Movable bearing units

BF

This movable bearing unit is a pedestal bearing with a deep-groove ball bearing that adapts itself axially to the elongation of the spindle.

The movable bearing unit is comprised of a burnished steel bearing case with 1 deep groove ball bearing.

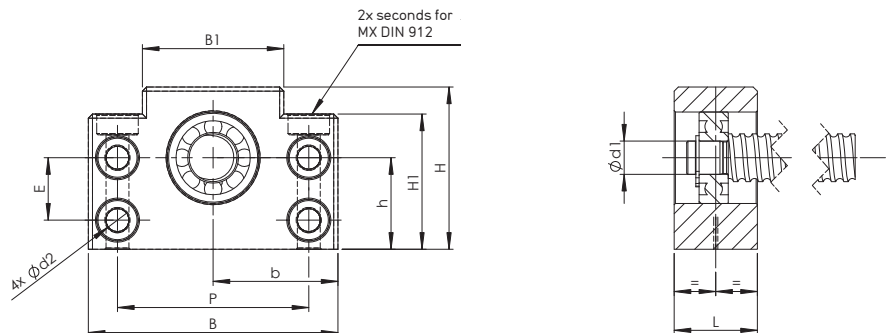
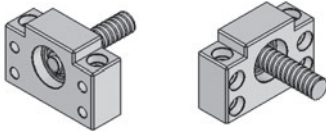

Size	Ø d ₁	L	B	H	b	h	B ₁	H ₁	E	P	Ø d ₂	M _x
BF 10	8	20	60	39	30	22	34	32.5	15	46	5.5	6
BF 12	10	20	60	43	30	25	35	32.5	18	46	5.5	6
BF 15	15	20	70	48	35	28	40	38	18	54	5.5	6
BF 17	17	23	86	64	43	39	50	55	28	68	6.6	8
BF 20	20	26	88	60	44	34	52	50	22	70	6.6	8
BF 25	25	30	106	80	53	48	64	70	33	85	9	10
BF 30	30	32	128	89	64	51	76	78	33	102	11	12
BF 35	35	32	140	96	70	52	88	79	35	114	11	12
BF 40	40	37	160	110	80	60	100	90	37	130	14	16

Bearing units

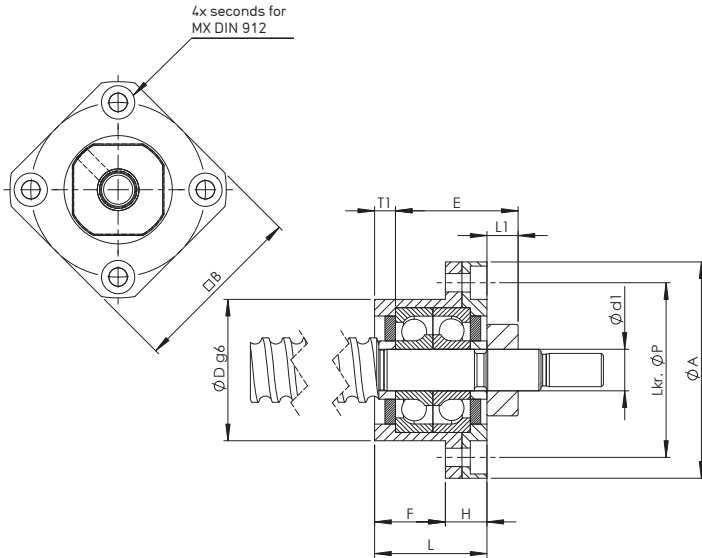

Fixed bearing units

FK

This fixed bearing unit is a flanged bearing with pre-tensioned axial-inclined ball bearings with seals.

The fixed bearing unit is comprised of a burnished steel bearing case with 2 axial inclined ball bearings pre-tensioned by means of a flange, 2 seals with circlips and a securable DRS grooved nut. (Square nuts are used for the smaller sizes).

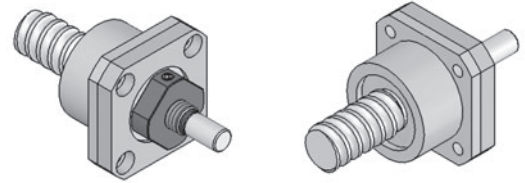

Size	$\varnothing d_1$	L	H	F	E	D_{g6}	A	Lkr. $\varnothing P$	B	L_1	T_1	M_x
FK 4	4	15	6	9	17.5	18	32	24	25	5.5	3	3
FK 5	5	16.5	6	10.5	18.5	20	34	26	26	5.5	3.5	3
FK 6	6	20	7	13	22	22	36	28	28	5.5	3.5	3
FK 8	8	23	9	14	26	28	43	35	35	7	4	3
FK 10	10	27	10	17	29.5	34	52	42	42	7.5	5	4
FK 12	12	27	10	17	29.5	36	54	44	44	7.5	5	4
FK 15	15	32	15	17	36	40	63	50	52	8	6	5
FK 20	20	52	22	30	50	57	85	70	68	10	10	6
FK 25	25	57	27	30	60	63	98	80	79	13	10	8
FK 30	30	62	30	32	61	75	117	95	93	11	12	10

Movable bearing units

FF

This movable bearing unit is a flanged bearing with a deep-groove ball bearing that adapts itself axially to the elongation of the spindle.

The movable bearing unit is comprised of a burnished steel bearing case with 1 deep groove ball bearing.

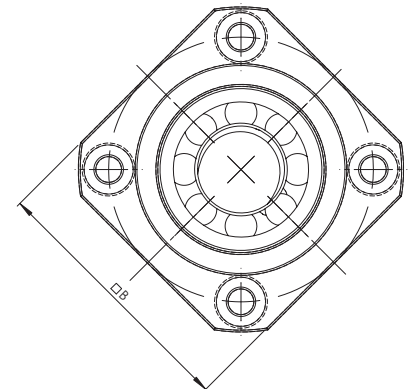
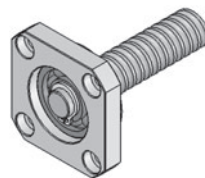
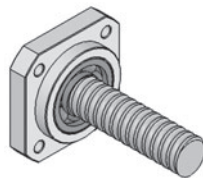
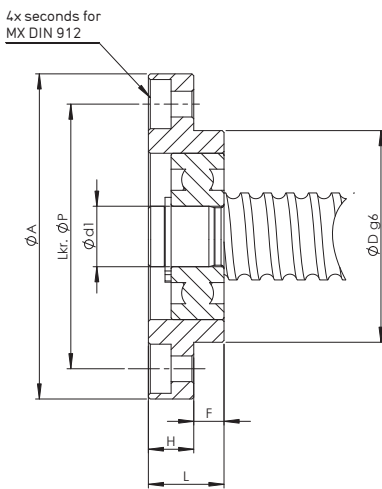

Size	$\varnothing d_1$	L	H	F	D_{g6}	A	Lkr. $\varnothing P$	B	M_x
FF 6	6	10	6	4	22	36	28	28	3.4
FF 10	8	12	7	5	28	43	35	35	3.4
FF 12	10	15	7	8	34	52	42	42	4.5
FF 15	15	17	9	8	40	63	50	52	5.5
FF 20	20	20	11	9	57	85	70	68	6.6
FF 25	25	24	14	10	63	98	80	79	9
FF 30	30	27	18	9	75	117	95	93	11

Bearing units

Fixed bearings

ZKLR

The ZKLR fixed bearing unit is an INA axial inclined ball bearing unit that is sealed on both sides by lip seals.

The bearing assembly is axially and radially pre-tensioned and provided with a large grease cup, so that it is maintenance-free for most applications.

The case is made of drawn sheet metal with an anti-rust coating.

The ZKLR fixed bearing units can be mounted directly on a machined surface without spigots or additional components. They align themselves on installation via the screw nut. As a result, stress due to misaligned bearing seats can be virtually ruled out.

The fixed bearing unit is comprised of a fixed bearing with axial inclined ball bearings that are sealed on both sides and a self-locking GUK grooved nut.

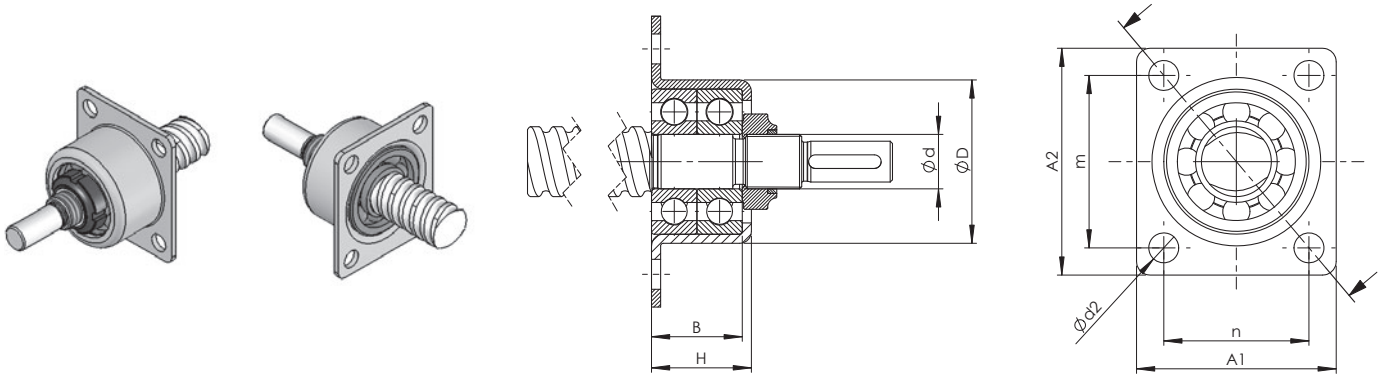

Size	ϕd	$\phi D^{+0.03}/_{-0.01}$	A_1	A_2	n	m	H	$B_{-0.25}$	ϕd_2
ZKLR 12	12	35.45	44	50	32	38	22	20	6.6
ZKLR 15	15	38.45	47	51	35	39	24	22	6.6
ZKLR 20	20	50.45	60	60	47	47	30	28	6.6

Grooved nuts

DRS

This is a securable grooved nut that is secured by two radial brass pins.

Material: heat treated steel, min. 800 N/mm²

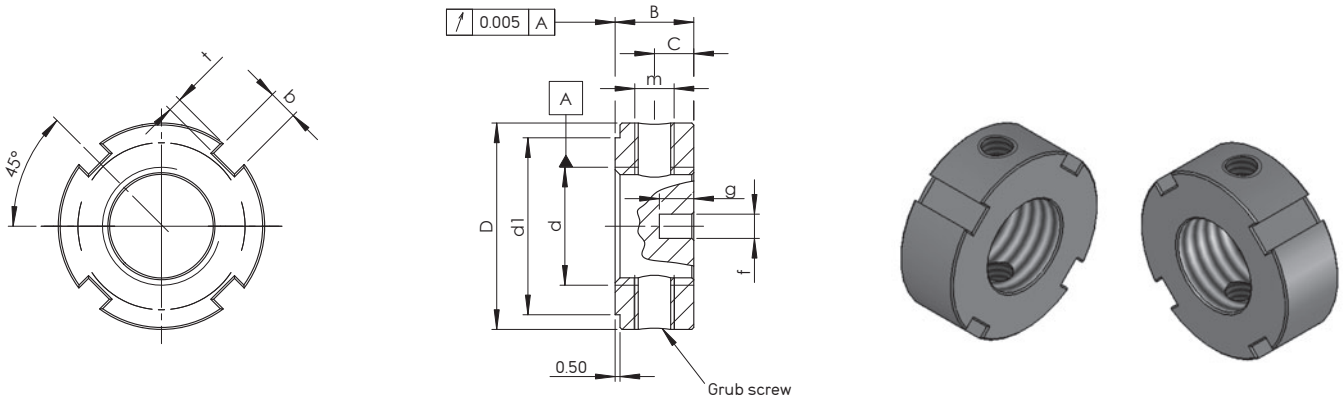

Size	d	D	B	d ₁	c	m	b	t	e	f	g	(Nm)
DRS 6x0.5	M 6x0.5	16	8	12	4	M4	3	2	11	2.5	3.5	2
DRS 10x1	M 10x1	18	8	14	4	M4	3	2	14	2.5	3.5	6
DRS 12x1	M 12x1	22	8	18	4	M4	3	2	17	2.5	3.5	8
DRS 17x1	M 17x1	28	10	23	5	M5	4	2	22.5	3	4	15
DRS 20x1	M 20x1	32	10	27	5	M5	4	2	26	3	4	18
DRS 30x1.5	M 30x1.5	45	12	40	6	M6	5	2	37.5	4	5	32
DRS 45x1.5	M 45x1.5	65	14	59	7	M6	6	2.5				65
DRS 55x2	M 55x2	75	16	68	8	M6	7	3				95
DRS 60x2	M 60x2	80	16	73	8	M6	7	3				100
DRS 70x2	M 70x2	92	18	85	9	M8	8	3.5				130
DRS 80x2	M 80x2	105	18	95	9	M8	8	3.5				160
DRS 90x2	M 90x2	120	20	108	10	M8	10	4				200

GUK

Self-locking grooved nut with polyamide ring.

Secured by a polyamide ring - usable up to max. 100 °C.

Material (strength class): min. 14 H, galvanised and passivated

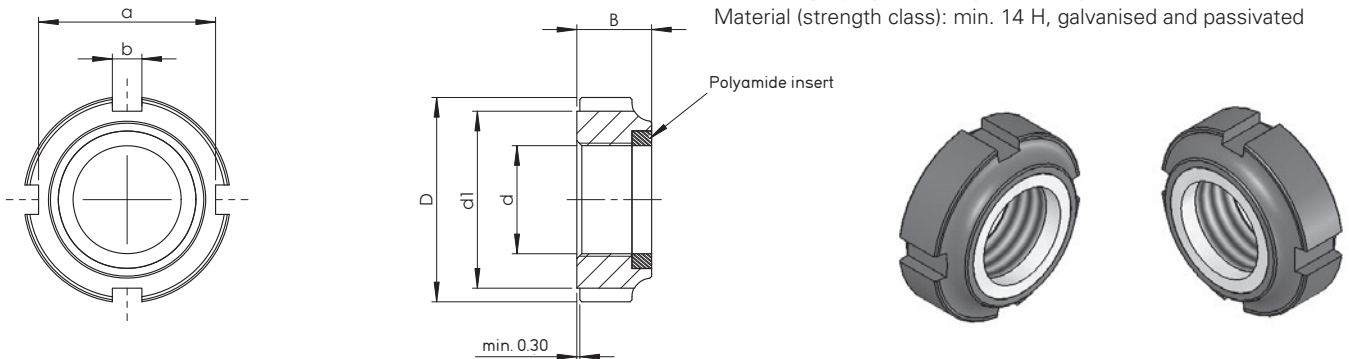

Size	d	D	B	d ₁	a	b	(Nm)	Weight
GUK 12x1	M 12x1	21	7.6	18	18	3	8	10
GUK 15x1	M 15x1	24	8.6	21	21	4	10	13
GUK 20x1	M 20x1	32	9.6	27	27	4	18	24

Trapezoidal nuts TGM

Short steel nut blank, cylindrical KSM

Suitable for clamping operations, manual positioning and mounting.
Not suitable for motion drives because the steel/steel friction tends to seizure.

Further processing: the thread serves as reference for precise machining and assembly.

Material: free-cutting steel 1.0718 (9 SMn 28K).

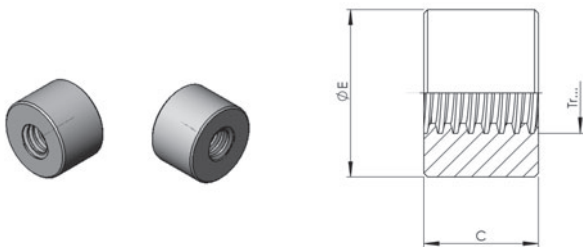

Type	E [mm]	C [mm]	Weight [kg]
KSM Tr 10x2	22	15	0.037
KSM Tr 10x3	22	15	0.036
KSM Tr 12x3	26	18	0.064
KSM Tr 14x3	30	21	0.96
KSM Tr 14x4	30	21	0.96
KSM Tr 16x4	36	24	0.16
KSM Tr 18x4	40	27	0.22
KSM Tr 20x4	45	30	0.31
KSM Tr 22x5	45	33	0.33
KSM Tr 24x5	50	36	0.45
KSM Tr 26x5	50	39	0.47
KSM Tr 28x5	60	42	0.76
KSM Tr 30x6	60	45	0.79
KSM Tr 32x6	60	48	0.81
KSM Tr 36x6	75	54	1.5
KSM Tr 40x7	80	60	1.9
KSM Tr 44x7	80	66	2.7
KSM Tr 48x8	90	72	2.9
KSM Tr 50x8	90	75	2.7
KSM Tr 60x9	100	90	3.7
KSM Tr 70x10	110	105	4.9
KSM Tr 80x10	120	120	6.4

Hexagonal steel nut blank SKM

For clamping operations, manual positioning and mounting. Not suitable for motion drives because the steel/steel friction tends to seizure.

Further processing: the thread serves as reference for precise machining and assembly.

Material: free-cutting steel 1.0718 (9 SMn 28K).

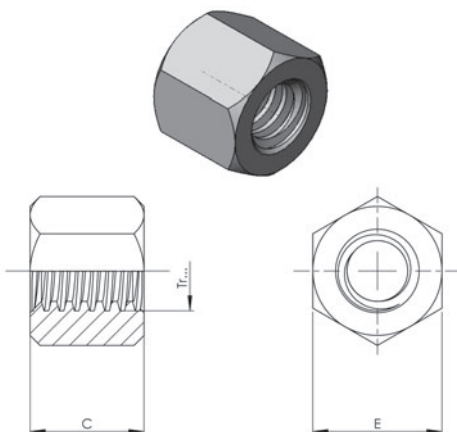

Type	E [mm]	C [mm]	Weight [kg]
SKM Tr 10x2	17	15	0.022
SKM Tr 10x3	17	15	0.022
SKM Tr 12x3	19	18	0.028
SKM Tr 14x3	22	21	0.044
SKM Tr 14x4	22	21	0.044
SKM Tr 16x4	27	24	0.084
SKM Tr 18x4	27	27	0.086
SKM Tr 20x4	30	30	0.17
SKM Tr 22x5	30	33	0.17
SKM Tr 24x5	36	36	0.20
SKM Tr 26x5	36	39	0.20
SKM Tr 28x5	41	42	0.30
SKM Tr 30x6	46	45	0.43
SKM Tr 32x6	46	48	0.42
SKM Tr 36x6	55	54	0.73
SKM Tr 40x7	65	60	1.3
SKM Tr 44x7	65	66	1.2
SKM Tr 48x8	75	72	1.8
SKM Tr 50x8	75	75	1.8
SKM Tr 60x9	90	90	2.8
SKM Tr 70x10	90	105	3.1

Trapezoidal nuts TGM

Type	E [mm]	C [mm]	Weight [kg]	Bearing surface [mm ²]
LRM Tr 10x2	22	20	0.056	200
LRM Tr 10x3	22	20	0.056	190
LRM Tr 12x3	26	24	0.092	280
LRM Tr 12x6 P3	26	24	0.092	280
LRM Tr 14x3	30	28	0.14	380
LRM Tr 14x4	30	28	0.14	370
LRM Tr 16x2	36	32	0.25	490
LRM Tr 16x4	36	32	0.25	490
LRM Tr 16x8 P4	36	32	0.25	490
LRM Tr 18x4	40	36	0.34	630
LRM Tr 20x4	45	40	0.48	790
LRM Tr 20x8 P4	45	40	0.45	790
LRM Tr 22x5	45	40	0.46	850
LRM Tr 22x24 P4S	45	40	0.46	880
LRM Tr 24x5	50	48	0.69	1130
LRM Tr 24x10 P5	50	48	0.65	1130
LRM Tr 26x5	50	48	0.58	1240
LRM Tr 28x5	60	60	1.2	1680
LRM Tr 30x6	60	60	1.2	1780
LRM Tr 30x12 P6	60	60	1.2	1780
LRM Tr 32x6	60	60	1.2	1910
LRM Tr 36x6	75	72	2.2	2610
LRM Tr 40x7	80	80	2.8	3210
LRM Tr 40x14 P7	80	80	2.8	3210
LRM Tr 44x7	80	80	2.6	3560
LRM Tr 48x8	90	100	4.3	4840
LRM Tr 50x8	90	100	4.2	5060
LRM Tr 60x9	100	120	5.7	7320
LRM Tr 70x10	110	140	7.6	10000
LRM Tr 80x10	120	160	9.7	13200

Long gunmetal nut blank, cylindrical LRM

For motion drives in continuous operation, with particularly good wear characteristics.

Further processing: The thread serves as a reference for precise machining and assembly.

Material: 2.1090 (G-CuSn 7Zn Pb (Rg7))

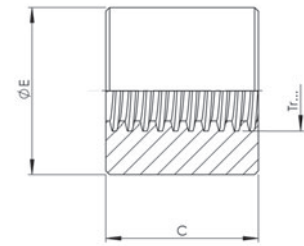
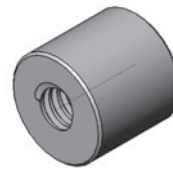

Trapezoidal nuts TGM

Complete bronze nut EFM

For motion drives in continuous operation, with particularly good wear characteristics. Suitable for use as a safety nut.

EFM nuts can be installed with the KON and KAR adapters.

Material: 2.1090 (G-CuSn 7Zn Pb (Rg7))

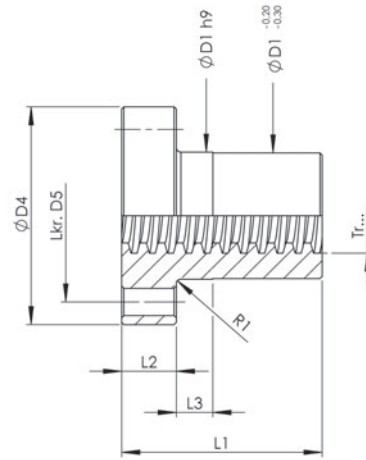
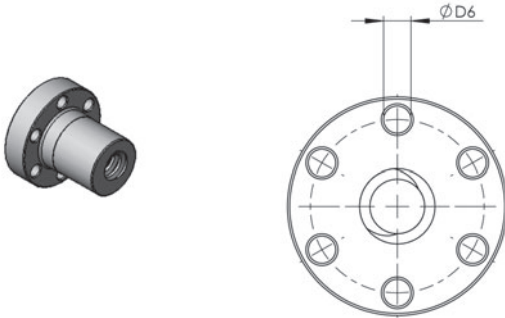

Type	Dimensions [mm]							Weight [kg]	Bearing surface [mm ²]
	D_1	D_4	D_5	$6xD_6$	L_1	L_2	L_3		
EFM Tr 12x3	24	40	32	4.5	28	12	10	0.11	520
EFM Tr 16x4	28	48	38	6	44	12	8	0.25	670
EFM Tr 18x4	28	48	38	6	44	12	8	0.25	770
EFM Tr 20x4	32	55	45	7	44	12	8	0.30	870
EFM Tr 24x5	32	55	45	7	44	12	8	0.30	1040
EFM Tr 30x6	38	62	50	7	46	14	8	0.40	1370
EFM Tr 36x6	45	70	58	7	59	16	10	0.60	2140
EFM Tr 40x7	63	95	78	9	73	16	10	1.70	2930
EFM Tr 50x8	72	110	90	11	97	18	10	2.60	4900
EFM Tr 60x9	85	125	105	11	99	20	10	3.70	6040
EFM Tr 70x10	95	140	180	17	100	30	16	7.80	8250
EFM Tr 80x10	105	150	190	17	110	30	16	8.90	10890

Long plastic nut blank, cylindrical LKM

For low-noise motion drives with higher speeds and longer operation time. Especially recommended in combination with rolled trapezoidal screws. Good emergency running characteristics.

Material: PETP

For lubrication we recommend the NEFF lubricant NLUB60.

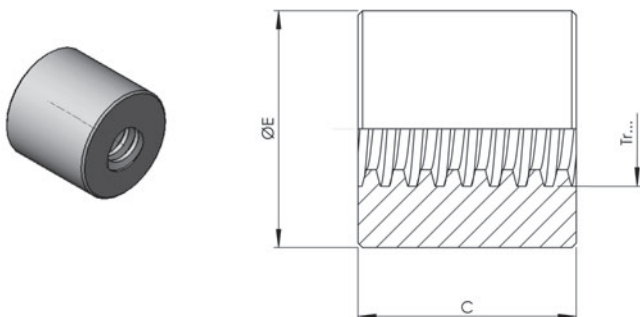

Type	E [mm]	C [mm]	Weight [kg]	Bearing surface [mm ²]
LKM Tr 12x3	26	24	0.012	280
LKM Tr 12x6 P3	26	24	0.012	280
LKM Tr 16x4	36	32	0.032	490
LKM Tr 16x8 P4	36	32	0.032	490
LKM Tr 20x4	45	40	0.06	790
LKM Tr 20x8 P4	45	40	0.06	790
LKM Tr 24x5	50	48	0.088	1130
LKM Tr 30x6	60	60	0.15	1780
LKM Tr 30x12 P6	60	60	0.15	1780
LKM Tr 36x6	75	72	0.30	2610
LKM Tr 40x7	80	80	0.37	3210
LKM Tr 50x8	90	100	0.55	5060

Material Characteristics

Material 2.1090

- 0.2 % yield strength $R_p 0.2$: _____ 120 N/mm²
- Tensile strength R_m (δB): _____ 240 N/mm²
- Min. strain at break A_5 min.: _____ 15 %
- Brinell hardness HB 10/1000: _____ 65
- Density: _____ 8.8 kg/dm³
- Modulus of elasticity: _____ 90000 N/mm²
- pv factor: _____ 300 N/mm² · m/min

Material PETP

- Tensile strength: _____ 80 N/mm²
- Modulus of elasticity: _____ 2800 – 3000 N/mm²
- Impact strength: _____ 40 kJm²
- Notch impact strength: _____ 4 kJm²
- Thermal expansion: _____ $8.5 \cdot 10^{-5}/^{\circ}C$
- Water absorption: _____ 0.25 %
- Water saturation: _____ 0.6 %
- Density: _____ 1.38 kg/dm³
- Friction against steel: _____ 0.05 – 0.08
- Ball pressure H 358/30: _____ 150 N/mm²
- Strain with a yield stress of 80 N/mm²: _____ 4 – 5 %
- pv factor: _____ 100 N/mm² · m/min
- Max. pressure per unit area: _____ 10 N/mm²
- Max. rubbing speed: _____ 120 m/min

Flanged ball nuts KGF-D

according to DIN 69051

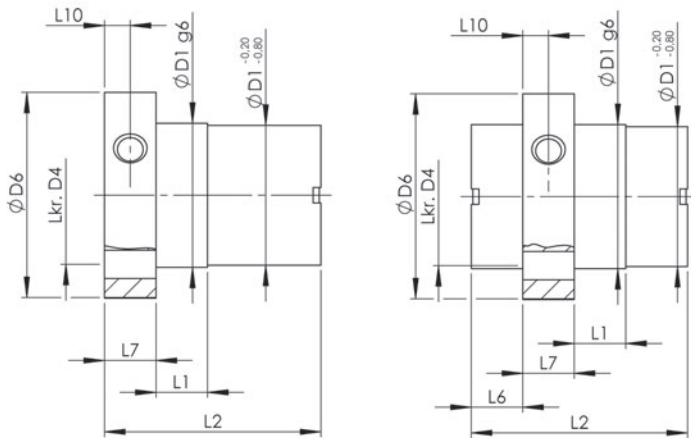

Form E

Form S

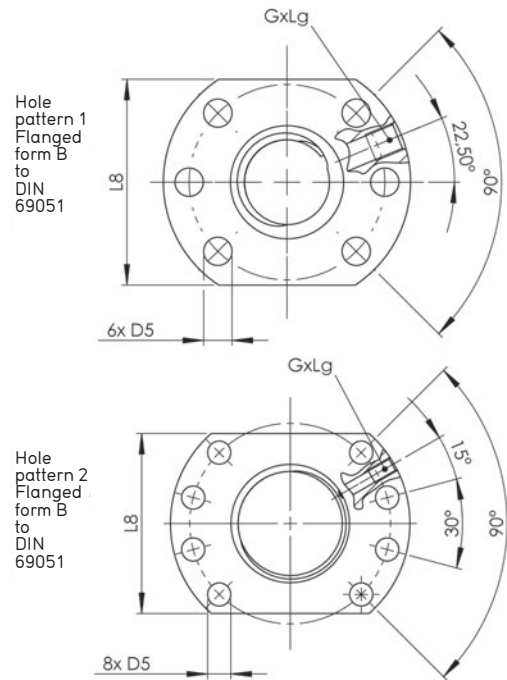
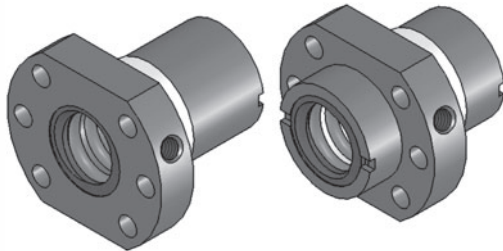

Material : 1.7131 (ESP65) or 1.3505 (100 Cr 6).

Type Diameter [mm] Lead [mm] Right hand thread	Form	Hole pattern	Dimensions [mm]													Axial backlash max [mm]	No. of circuits	Load rating [kN]		
			D ₁	D ₄	D ₅	D ₆	L ₁	L ₂	L ₆	L ₇	L ₈	L ₉	L ₁₀	Lubrication hole G	C ⁽²⁾			C ⁽³⁾	C ₀ = C _{0a}	
KGF-D 1605 RH-EE	E	1	28	38	5.5	48	10	42	–	10	40	10	5	M 6	0.08	3	12.0	9.3	13.1	
KGF-D 1610 RH-EE	E	1	28	38	5.5	48	10	55	–	10	40	10	5	M 6	0.08	6	23.0	15.4	26.5	
KGF-D 2005 RH-EE	E	1	36	47	6.6	58	10	42	–	10	44	10	5	M 6	0.08	3	14.0	10.5	16.6	
KGF-D 2505 RH-EE	E	1	40	51	6.6	62	10	42	–	10	48	10	5	M 6	0.08	3	15.0	12.3	22.5	
KGF-D 2510 RH-EE	E	1	40	51	6.6	62	16	55	–	10	48	10	5	M 6	0.08	3	17.5	13.2	25.3	
KGF-D 2520 RH-EE	S	1	40	51	6.6	62	4	35	10.5	10	48	8	5	M 6	0.15	4	19.0	13.0	23.3	
KGF-D 2525 RH-EE	S	1	40	51	6.6	62	9	35	8	10	48	8	5	M 6	0.08	5	21.0	16.7	32.2	
KGF-D 2550 RH-EE	S	1	40	51	6.6	62	10	58	10.0	10	48	8	5	M 6	0.15	5	22.5	15.4	31.7	
KGF-D 3205 RH-EE	E	1	50	65	9	80	10	55	–	12	62	10	6	M 6	0.08	5	24.0	21.5	49.3	
KGF-D 3210 RH-EE ⁵⁾	E	1	53 ¹⁾	65	9	80	16	69	–	12	62	10	6	M 8x1	0.08	3	44.0	33.4	54.5	
KGF-D 3220 RH-EE	E	1	53 ¹⁾	65	9	80	16	80	–	12	62	10	6	M 6	0.08	4	42.5	29.7	59.8	
KGF-D 4005 RH-EE	E	2	63	78	9	93	10	57	–	14	70	10	7	M 6	0.08	5	26.0	23.8	63.1	
KGF-D 4010 RH-EE	E	2	63	78	9	93	16	71	–	14	70	10	7	M 8x1	0.08	3	50.0	38.0	69.1	
KGF-D 4020 RH-EE	E	2	63	78	9	93	16	80	–	14	70	10	7	M 8x1	0.08	4	44.5	33.3	76.1	
KGF-D 4040 RH-EE	S	2	63	78	9	93	16	85	7.5	14	– ⁴⁾	10	7	M 8x1	0.08	8	42.0	35.0	101.9	
KGF-D 5010 RH-EE	E	2	75	93	11	110	16	95	–	16	85	10	8	M 8x1	0.08	5	78.0	68.7	155.8	
KGF-D 5020 RH-EE	E	2	85 ¹⁾	103 ¹⁾	11	125	22	95	–	18	95	10	9	M 8x1	0.08	4	82.0	60.0	136.3	
Left hand thread																				
KGF-D 2005 LH-EE	E	1	36	47	6.6	58	10	42	–	10	44	10	5	M 6	0.08	3	16.5	10.5	16.6	

¹⁾ D₁ not conforming to DIN 69051.

²⁾ Dynamic load rating according to DIN 69051 part 4 draft 1978.

³⁾ Dynamic load rating according to DIN 69051 part 4 draft 1989.

⁴⁾ Round flange.

⁵⁾ Also available with Ø 50 mm according to DIN.

Flanged ball nuts KGF-N

according to NEFF standard

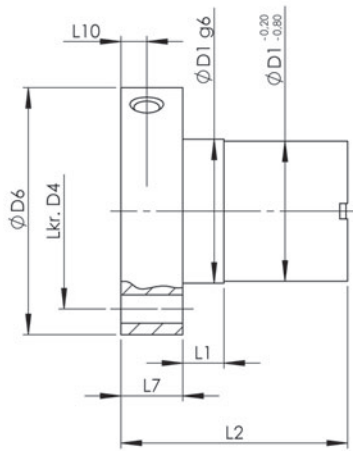

Form E

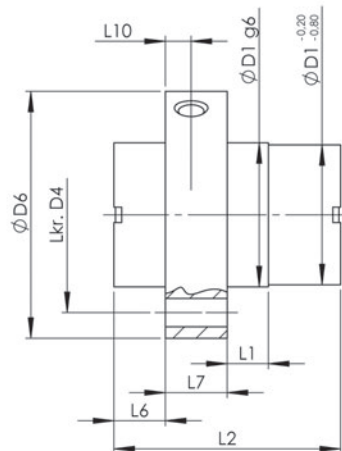

Form S

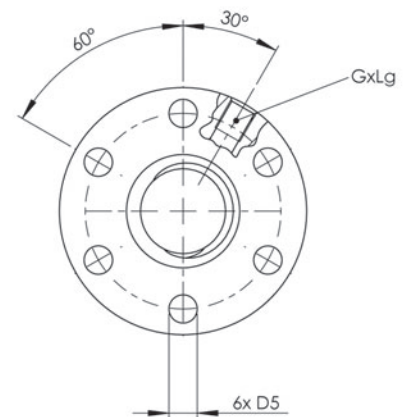

Hole pattern 3
NEFF standard

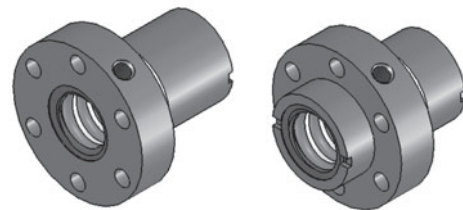

Material: 1.7131 (ESP65) or 1.3505 (100 Cr 6).

Type Diameter [mm] Lead [mm] Right hand thread	Form	Dimensions [mm]											Axial backlash max [mm]	No. of circuits	Load rating [kN]		
		D ₁	D ₄	D ₅	D ₆	L ₁	L ₂	L ₆	L ₇	L ₉	L ₁₀	Lubrication hole G			C ¹⁾	C ²⁾	C ₀ = C _{0a}
KGF-N 1605 RH-EE	E	28	38	5.5	48	8	44	–	12	8	6	M 6	0.08	3	12.0	9.3	13.1
KGF-N 2005 RH-EE	E	32	45	7	55	8	44	–	12	8	6	M 6	0.08	3	14.0	10.5	16.6
KGF-N 2020 RH-EE	S	35	50	7	62	4	30	8	10	8	5	M 6	0.08	4	12.0	11.6	18.4
KGF-N 2050 RH-EE	S	35	50	7	62	10	56	9	10	8	5	M 6	0.15	5	18.0	13.0	24.6
KGF-N 2505 RH-EE	E	38	50	7	62	8	46	–	14	8	7	M 6	0.08	3	15.0	12.3	22.5
KGF-N 3205 RH-EE	E	45	58	7	70	10	59	–	16	8	8	M 6	0.08	5	24.0	21.5	49.3
KGF-N 3210 RH-EE	E	53	68	7	80	10	73	–	16	8	8	M 8x1	0.08	3	44.0	33.4	54.5
KGF-N 3240 RH-EE	S	53	68	7	80	14	45	7.5	16	10	8	M 6	0.08	4	17.0	14.9	32.4
KGF-N 4005 RH-EE	E	53	68	7	80	10	59	–	16	8	8	M 6	0.08	5	26.0	23.8	63.1
KGF-N 4010 RH-EE	E	63	78	9	95	10	73	–	16	8	8	M 8x1	0.08	3	50.0	38.0	69.1
KGF-N 5010 RH-EE	E	72	90	11	110	10	97	–	18	8	9	M 8x1	0.08	5	78.0	68.7	155.8
KGF-N 6310 RH-EE	E	85	105	11	125	10	99	–	20	8	10	M 8x1	0.08	5	86.0	76.0	197.0

¹⁾ Dynamic load rating according to DIN 69051 part 4 draft 1978.
²⁾ Dynamic load rating according to DIN 69051 part 4 draft 1989.

Cylindrical ball nuts

KGM-D

according to DIN 69051

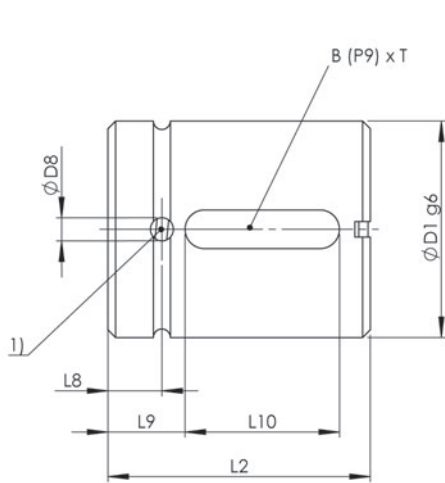

Form E

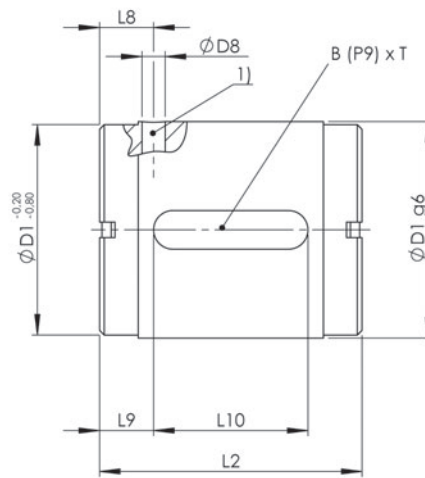

Form S

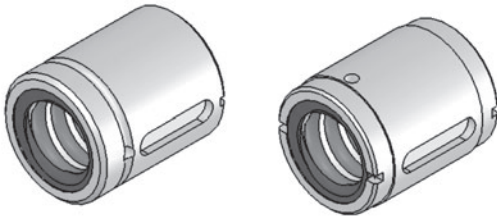

Material: 1.7131 (ESP65) or 1.3505 (100 Cr 6).

Type Diameter [mm] Lead [mm] Right hand thread	Form	Dimensions [mm]							Axial backlash max [mm]	No. of circuits	Load rating [kN]		
		D_1	D_8	L_2	L_8	L_9	L_{10}	BxT			$C^{2)}$	$C^{3)}$	$C_o = C_{oa}$
KGM-D 1605 RH-EE	E	28	3	34	7	7	20	5x2	0.08	3	12.5	9.3	13.1
KGM-D 1610 RH-EE	E	28	3	50	7	15	20	5x2	0.08	6	23.0	15.4	26.5
KGM-D 2005 RH-EE	E	36	3	34	7	7	20	5x2	0.08	3	14.0	10.5	16.6
KGM-D 2505 RH-EE	E	40	3	34	7	7	20	5x2	0.08	3	15.0	12.3	22.5
KGM-D 2510 RH-EE	E	40	3	45	7.5	12.5	20	5x2	0.08	3	17.5	13.2	25.3
KGM-D 2520 RH-EE	S	40	1.5	35	14	11.5	12	5x3	0.15	4	19.0	13.0	23.3
KGM-D 2525 RH-EE	S	40	1.5	35	11.5	11	13	5x3	0.08	5	21.0	16.7	32.2
KGM-D 2550 RH-EE	S	40	1.5	58	17	19	20	5x3	0.15	5	22.5	15.4	31.7
KGM-D 3205 RH-EE	E	50	3	45	7.5	8	30	6x2.5	0.08	5	24.0	21.5	49.3
KGM-D 4005 RH-EE	E	63	3	45	7.5	8	30	6x2.5	0.08	5	26.0	23.8	63.1
KGM-D 4010 RH-EE	E	63	4	60	10	15	30	6x2.5	0.08	3	50.0	38.0	69.1
KGM-D 4020 RH-EE	E	63	3	70	7.5	20	30	6x2.5	0.08	4	44.5	33.3	76.1
KGM-D 4040 RH-EE	S	63	1.5	85	15	27.5	30	6x3.5	0.08	8	42.0	35.0	101.9
Left hand thread													
KGM-D 2005 LH-EE	E	36	3	34	7	7	20	5x2	0.08	3	16.5	10.5	16.6

¹⁾ Position of grease holes not defined on circumference.

²⁾ Dynamic load rating according to DIN 69051 part 4 draft 1978.

³⁾ Dynamic load rating according to DIN 69051 part 4 draft 1989.

Cylindrical ball nuts KGM-N

according to NEFF standard

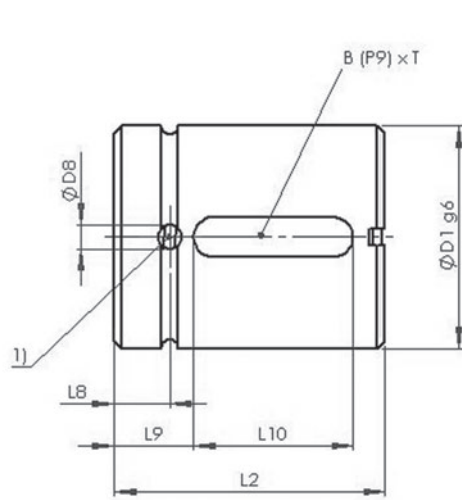

Form E

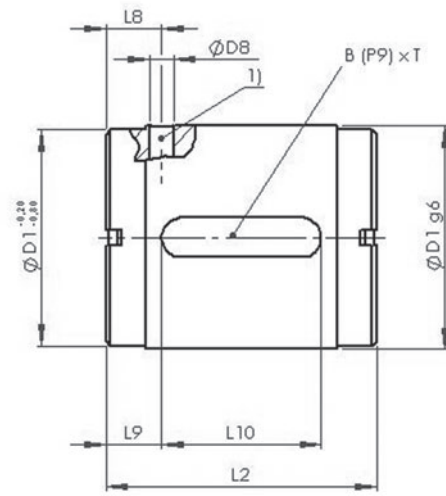

Form S

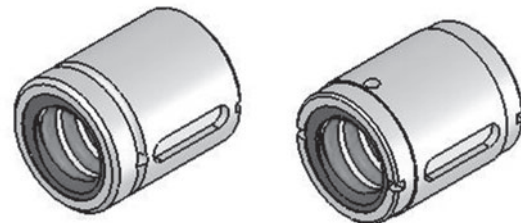

Material: 1.7131 (ESP65) or 1.3505 (100 Cr 6).

Type Diameter [mm] Lead [mm] Right hand thread	Form	Dimensions [mm]							Axial backlash max [mm]	No. of circuits	Load rating [kN]		
		D_1	D_8	L_2	L_8	L_9	L_{10}	BxT			$C^{(2)}$	$C^{(3)}$	$C_0 = C_{0a}$
KGM-N 1205 RH-00	E	20 ⁴⁾	–	24	–	5	14	3x1.8	0.08	3	6.0	4.4	6.8
KGM-N 2005 RH-EE	E	32	3	34	7	7	20	5x2	0.08	3	14.0	10.5	16.6
KGM-N 2020 RH-EE	S	35	1.5	30	11.5	9	12	5x3	0.08	4	12.0	11.6	18.4
KGM-N 2050 RH-EE	S	35	1.5	56	16	18	20	5x3	0.15	5	18.0	13.0	24.6
KGM-N 2505 RH-EE	E	38	3	34	7	7	20	5x2	0.08	3	15.0	12.3	22.5
KGM-N 3205 RH-EE	E	45	3	45	7.5	8	30	6x2.5	0.08	5	24.0	21.5	49.3
KGM-N 3210 RH-EE	E	53	4	60	10	15	30	6x2.5	0.08	3	44.0	33.4	54.5
KGM-N 3220 RH-EE	E	53	3	70	7.5	20	30	6x2.5	0.08	4	42.5	29.7	59.8
KGM-N 3240 RH-EE	S	53 ⁵⁾	1.5	45	13	10	25	6x4	0.08	4	17.0	14.9	32.4
KGM-N 4005 RH-EE	E	53	3	45	7.5	8	30	6x2.5	0.08	5	26.0	23.8	63.1
KGM-N 5010 RH-EE	E	72	4	82	11	23	36	6x2.5	0.08	5	78.0	68.7	155.8
KGM-N 5020 RH-EE	E	85	4	82	10	23	36	6x2.5	0.08	4	82.0	60.0	136.3
KGM-N 6310 RH-EE	E	85	4	82	11	23	36	6x2.5	0.08	5	86.0	76.0	197.0

¹⁾ Position of grease holes not defined on circumference.

²⁾ Dynamic load rating according to DIN 69051 part 4 draft 1978.

³⁾ Dynamic load rating according to DIN 69051 part 4 draft 1989.

⁴⁾ Nut without wiper.

⁵⁾ $D_1 -0,2/-0,8$ does not apply, therefore $D_1 -1,0/-1,5$.

Ball nuts KGM-E

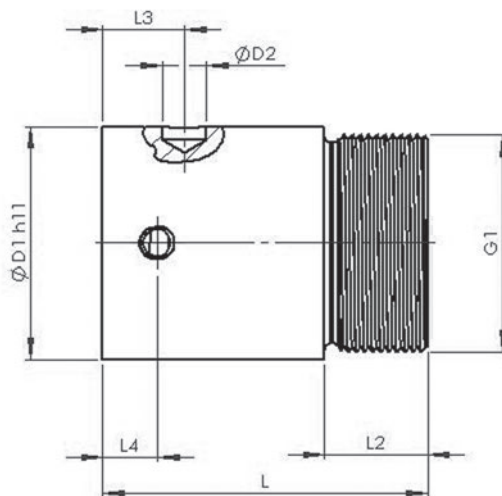
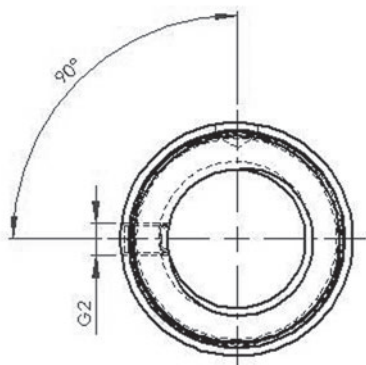

The ball nut can be adjusted anti backlash by means of ball selection.

Material: 16 MnCr 5 or 100 Cr 6

Axial backlash: at lead P5 = 0.05 mm
at lead P10 = 0.10 mm

Size	Dimensions [mm]								
	D1h11	D2	L	L2	L3	L4	G1	G2	W
KGM-E-1605-RH	32	3.2	42	12	3		M26x1.5		
KGM-E-2005-RH	38	8	45	14	8	8	M35x1.5	M6	90°
KGM-E-2505-RH	43	8	60	19	15	10	M40x1.5	M6	90°
KGM-E-2510-RH	43	8	74	19	16	16	M40x1.5	M6	180°
KGM-E-3205-RH	52	8	63	19	15	10	M48x1.5	M6	90°
KGM-E-3210-RH	54	8	78	19	8	8	M48x1.5	M6	90°
KGM-E-4005-RH	60	8	63	19	15	10	M56x1.5	M8x1	90°
KGM-E-4010-RH	65	8	84	24	15	8	M60x2	M8x1	90°
KGM-AE-5010-RH	78	8	111	29	15	8	M72x2	M8x1	90°

The range includes a total of 11 worm gear screw jack models in two series: M 0 – M 5 with lifting capacities from 2.5 kN to 100 kN and J 1 – J 5 with lifting capacities from 150 kN to 500 kN statically.

Speed of travel

Gear Ratio H (high speed)

Worm gear screw jacks with trapezoidal screw produce an advance of 1 mm for each full revolution of the worm shaft. That is, the linear speed is 1500 mm per min at 1500 rpm. Worm gear screw jacks with ball screw achieve 6000 mm/min, depending on size and lead.

Gear Ratio L (low speed)

Worm gear screw jacks with trapezoidal screw produce an advance of 0.25 mm for each full revolution of the worm shaft. That is, the linear speed is 375 mm per min at 1500 rpm.

Please note that higher speeds of travel can be achieved with larger screw leads or multiple start screws. The worm gear screw jack's maximum drive revs of 3000 rpm must not be exceeded. The higher efficiency of the ball screw drive also permits a longer duty cycle.

Tolerances and backlash

- The gearbox housings are machined on the six mounting sides. The tolerances conform to DIN ISO 2768-mH.
- The axial backlash of the jack screw under alternating load is as follows:
 - Trapezoidal screws: up to 0.4 mm (to DIN 103)
 - Ball screws: 0.07 mm.
- The lateral play between the outside diameter of the screw and the guide diameter is 0.2 mm.
- The backlash in the worm gears is $\pm 4^\circ$ for gear ratio L and $\pm 1^\circ$ for gear ratio H based on the drive shaft.
- Trapezoidal screws are manufactured to a straightness of 0.3 – 1.5 mm/m, ball screws to a straightness of 0.02 mm/m over a length of 1000 mm and to the following lead accuracies:
 - M 0 – M 5: 0.05 mm/300 mm length
 - J 1 – J 5: 0.2 mm/300 mm length.

Lateral forces on the jack screw.

Lateral forces can be absorbed by our screw jacks too. Please contact us.

Worm Gear Screw Jacks

Stop collar A

Prevents the screw from being removed from the jack gearbox. Fitted as standard on ball screw versions N and V. Optionally available for screw jacks with trapezoidal screw. The stop collar cannot be used as a fixed stop.

Self-locking

The self-locking function depends on a variety of parameters:

- High leads
- Different gear ratios
- Lubrication
- Friction parameters
- Ambient influences, such as high or low temperatures, vibrations, etc.
- The mounting position

Versions with ball screw and TGS/KGS with high leads are consequently not self-locking. Suitable brakes or braking motors must therefore be considered in such cases. Limited self-locking is available for smaller leads (single-start). Self locking in individual cases on demand.

Special versions

In addition to the extensive standard range, NEFF can also supply anticlockwise, multi-start and special material worm gear screw jacks on request.

General technical data

Worm Gear Screw Jacks

Trapezoidal screw

		M 0	M 1	M 2	M 3	M 4	M 5	J 1	J 2	J 3	J 4	J 5
Maximum lifting capacity [kN] ¹⁾		2.5	5	10	25	50	100	150	200	250	350	500
Screw diameter and lead [mm]		14 x 4	18 x 4	20 x 4	30 x 6	40 x 7	55 x 9	60 x 9	70 x 10	80 x 10	100 x 10	120 x 14
Stroke in mm per full turn of the drive shaft [mm]	Ratio H ²⁾	1	1	1	1	1	1	1	1	1	1	1
	Ratio L ²⁾	0.25	0.25	0.25	0.25	0.25	0.25	0.25	0.25	0.25	0.25	0.25
Gear ratio	Ratio H ²⁾	4:1	4:1	4:1	6:1	7:1	9:1	9:1	10:1	10:1	10:1	14:1
	Ratio L ²⁾	16:1	16:1	16:1	24:1	28:1	36:1	36:1	40:1	40:1	40:1	56:1
Efficiency [%] ³⁾	Ratio H ²⁾	35	31	29	29	26	24	23	22	20	19	19
	Ratio L ²⁾	27	25	23	23	21	19	18	17	15	15	15
Weight [kg] (zero stroke)		0.6	1.2	2.1	6	17	32	41	57	57	85	160
Weight [kg per 100 mm stroke]		0.1	0.26	0.42	1.14	1.67	3.04	3.1	4.45	6.13	7.9	11,5
Idling torque [Nm]	H	0.02	0.04	0.11	0.15	0.35	0.84	0.88	1.28	1.32	1.62	1,98
	L	0.016	0.03	0.10	0.12	0.25	0.51	0.57	0.92	0.97	1.10	1,42
Housing material		G – AL				GGG – 40						

Ball screws

		M 0	M 1	M 2	M 3	M 4		M 5	J 3
Maximum lifting capacity [kN] ¹⁾		2	5	10	12.5	22	42	65	78
Screw diameter and pitch [mm]		1205	1605	2005	2505	4005	4010	5010	8010
Stroke in mm per full turn of the drive shaft [mm]	Ratio H ²⁾	1.25	1.25	1.25	0.83	0.71	1.43	1.1	1
	Ratio L ²⁾	0.31	0.31	0.31	0.21	0.18	0.36	0.28	0.25
Gear ratio	Ratio H ²⁾	4:1	4:1	4:1	6:1	7:1		9:1	10:1
	Ratio L ²⁾	16:1	16:1	16:1	24:1	28:1		36:1	40:1
Efficiency [%] ³⁾	Ratio H ²⁾	60	57	56	55	53	56	47	45
	Ratio L ²⁾	48	46	44	43	43	45	37	34
Weight [kg] (zero stroke)		0.6	1.3	2.3	7	19		35	63
Weight [kg per 100 mm stroke]		0.09	0.26	0.42	1.14	1.67		3.04	6.13
Idling torque [Nm]	H	0.02	0.04	0.11	0.15	0.35		0.84	1.32
	L	0.016	0.03	0.10	0.12	0.25		0.51	0.97
Housing material		G – AL				GGG – 40			

Note: Initial breakaway torque: approx. 2 – 3 times nominal torque in run-up (Frequency inverter control!)

¹⁾ Dependent on speed of stroke, power-on time, etc.

²⁾ H = high travel speed,

L = low travel speed.

³⁾ The specified efficiency values are average values.

Dimensions, version N, V

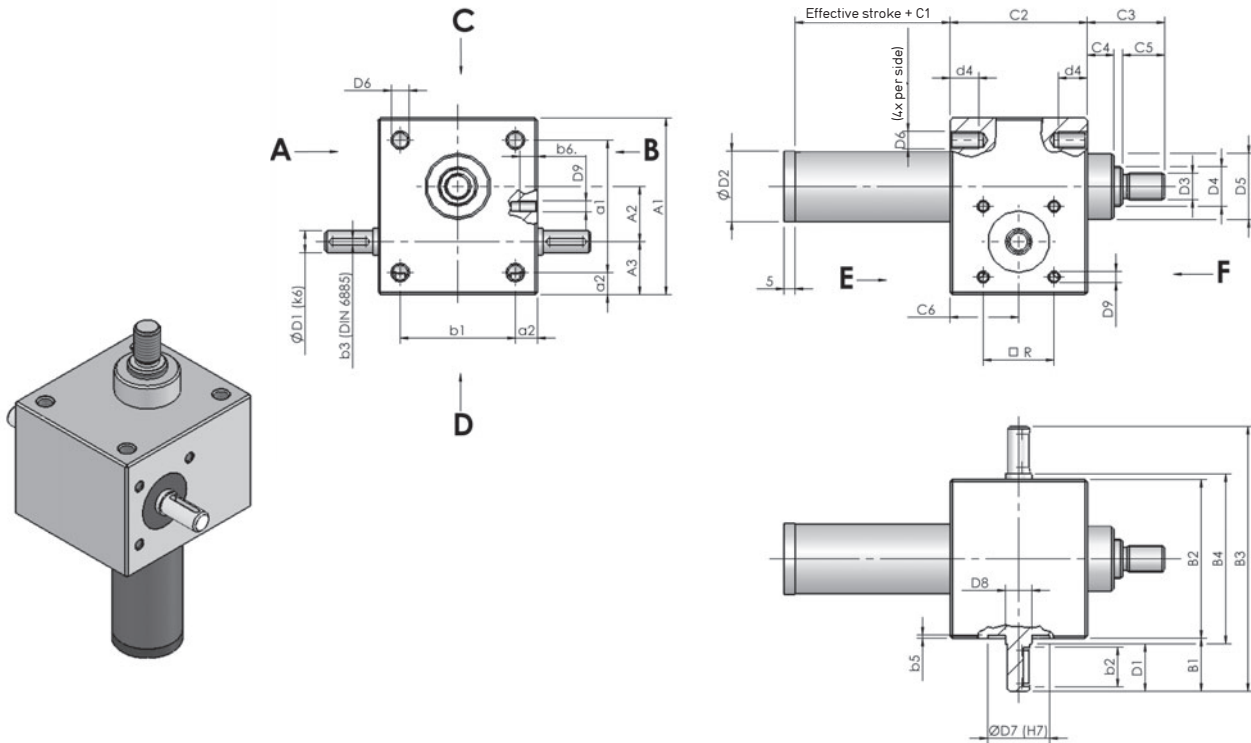

Size	Dimensions [mm]																
	A ₁	A ₂	A ₃	a ₁	a ₂	B ₁	B ₂	B ₃	B ₄	b ₁	b ₂	b ₃	b ₄	b ₅	C ₁	C ₂	C ₃
M 0	60	20	18	48	6	20	50	92	52	38	14	3	12	1.5	20	50	27
M 1	80	25	24	60	10	24	72	120	77	52	18	3	13	1.5	20	62	35
M 2	100	32	28	78	11	27.5	85	140	90	63	20	5	15	1.5	30	75	45
M 3	130	45	31	106	12	45	105	195	110	81	36	5	15	2	30	82	50
M 4	180	63	39	150	15	47.5	145	240	150	115	36	6	16	2	45	117	65
M 5	200	71	46	166	17	67.5	165	300	170	131	56	8	30	2.5	55	160	95
J 1	210	71	49	170	20	65	195	325	200	155	56	8	40	8	55	175	95
J 2	240	80	60	190	25	67.5	220	355	225	170	56	8	45	8	55	165	110
J 3	240	80	60	190	25	67.5	220	355	225	170	56	8	45	8	55	165	110
J 4	290	100	65	230	30	65	250	380	255	190	56	10	54	8	65	220	140
J 5	360	135	75	290	35	100	300	500	305	230	90	14	80	8	90	266	200

Size	Dimensions [mm]															
	C ₄	C ₅	C ₆	D _{1k6}	D ₂	D ₃	D _{4Tr}	D _{4KGT}	D ₅	D ₆	D _{7^{H7}}	D ₈	D ₉ x b ₆	□ R	V-KGT	
M 0	12	12	25	9 x 20	28	M8 x 1.25	Tr14 x 4	1205	26	M6	22	10	M6 x 8	24	25 x 25	
M 1	12	19	31	10 x 21.5	32	M12 x 1.75	Tr18 x 4	1605	30	M8	28	12	M6 x 8	32	30 x 30	
M 2	18	20	37.5	14 x 25	40	M14 x 2.0	Tr20 x 4	2005	38.7	M8	35	15	M6 x 10	35	40 x 40	
M 3	23	22	41	16 x 42.5	50	M20 x 2.5	Tr30 x 6	2505	46	M10	40	17	M8 x 10	44	50 x 50	
M 4	32	29	58.5	20 x 45	60	M30 x 3.5	Tr40 x 7	4005/4010	60	M12	52	25	M10 x 14	55	60 x 60	
M 5	40	48	80	25 x 65	82	M36 x 4	Tr55 x 9	5010	85	M20	52	28	M12 x 16	70	80 x 80	
J 1	40	48	87.5	25 x 62.5	90	M48 x 2	Tr60 x 9	—	90	M24	52	28	M12 x 16	70	—	
J 2	40	58	82.5	30 x 65	115	M56 x 2	Tr70 x 10	—	105	M30	58	32	M12 x 18	(80)	—	
J 3	40	58	82.5	30 x 65	115	M64 x 3	Tr80 x 10	8010	120	M30	58	32	M12 x 18	(80)	120 x 120	
J 4	50	78	110	35 x 62.5	133	M72 x 3	Tr100 x 10	—	145	M36	72	40	M16 x 30	(100)	—	
J 5	60	118	133	48 x 97.5	153	M100 x 3	Tr120 x 14	—	170	M42	80	50	M16 x 40	(115)	—	

Note: Subject to change without notice.

Dimensions, version R

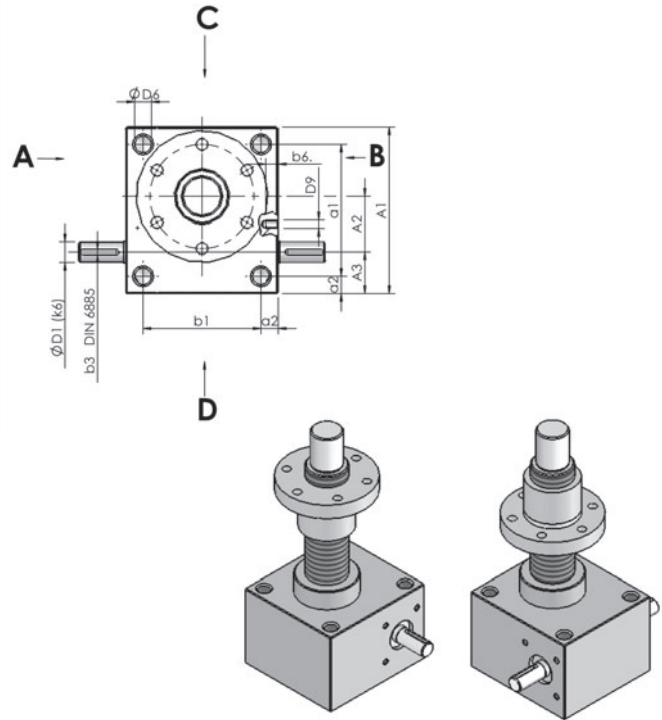
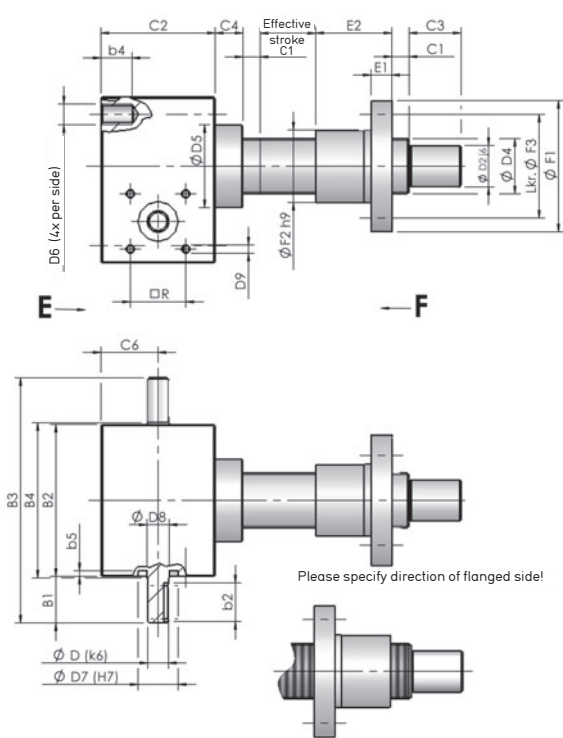

Size	Dimensions [mm]																		
	A ₁	A ₂	A ₃	a ₁	a ₂	B ₁	B ₂	B ₃	B ₄	b ₁	b ₂	b ₃	b ₄	b ₅	C ₁	C ₂	C ₃	C ₄	C ₆
M 0	60	20	18	48	6	20	50	92	52	38	14	3	12	1.5	10	50	12	12	25
M 1	80	25	24	60	10	24	72	120	77	52	18	3	13	1.5	12	62	15	12	31
M 2	100	32	28	78	11	27.5	85	140	90	63	20	5	15	1.5	15	75	20	18	37.5
M 3	130	45	31	106	12	45	105	195	110	81	36	5	15	2	20	82	25	23	41
M 4	180	63	39	150	15	47.5	145	240	150	115	36	6	16	2	25	117	30	32	58.5
M 5	200	71	46	166	17	67.5	165	300	170	131	56	8	30	2.5	25	160	45	40	80
J 1	210	71	49	170	20	65	195	325	200	155	56	8	40	8	25	175	55	40	87.5
J 2	240	80	60	190	25	67.5	220	355	225	170	56	8	45	8	25	165	70	40	82.5
J 3	240	80	60	190	25	67.5	220	355	225	170	56	8	45	8	25	165	75	40	82.5
J 4	290	100	65	230	30	65	250	380	255	190	56	10	54	8	25	220	100	50	110
J 5	360	135	75	290	35	100	300	500	305	230	90	14	80	8	30	266	120	60	133

Size	Dimensions [mm]																
	D _{1k6}	D _{2i6}	D _{4TR}	D _{4KGT}	D ₅	D ₆	D _{7H7}	D ₈	D ₉ x b ₆	□ R	E ₁	E ₂	F ₁	F ₂	F ₃	F ₄	
M 0	9 x 20	8	Tr14 x 4	1205	26	M6	22	10	M6 x 8	24	12	35	48	28	38	6	
M 1	10 x 21.5	12	Tr18 x 4	1605	30	M8	28	12	M6 x 8	32	12/12	44/44	48/48	28/28	38/38	6/6	
M 2	14 x 25	15	Tr20 x 4	2005	38.7	M8	35	15	M6 x 10	35	12/12	44/44	55/55	32/32	45/45	7/7	
M 3	16 x 42.5	20	Tr30 x 6	2505	46	M10	40	17	M8 x 10	44	14/14	46/46	62/62	38/38	50/50	7/7	
M 4	20 x 45	25	Tr40 x 7	4005/4010	60	M12	52	25	M10 x 14	55	16/16	73/59	95/80	63/53	78/68	9/7	
M 5	25 x 65	40	Tr55 x 9	5010	85	M20	52	28	M12 x 16	70	18/18	97/97	110/110	72/72	90/90	11/11	
J 1	25 x 62.5	45	Tr60 x 9	—	90	M24	52	28	M12 x 16	70	20	99	125	85	105	11	
J 2	30 x 65	55	Tr70 x 10	—	105	M30	58	32	M12 x 18	(80)	30	100	180	95	140	17	
J 3 M 6	30 x 65	60	Tr80 x 10	8010	120	M30	58	32	M12 x 18	(80)	30/22	110/101	190/145	105/105	150/125	17/14	
J 4 M 7	35 x 62.5	80	Tr100 x 10	—	145	M36	72	40	M16 x 30	(100)	35	130	240	130	185	25	
J 5 M 8	48 x 97.5	95	Tr120 x 14	—	170	M42	80	50	M16 x 40	(115)	40	160	300	160	230	28	

Note: Subject to change without notice.

Mountings

Mounting feet BL-L

Supplied loose with mounting bolts for jack. Burnished.
M 1 + 2 with version N-KGT not on side F. Standard: side E.

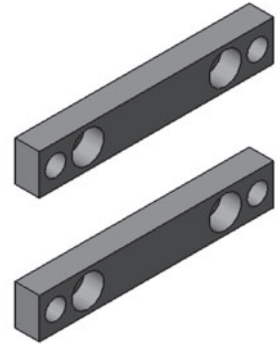
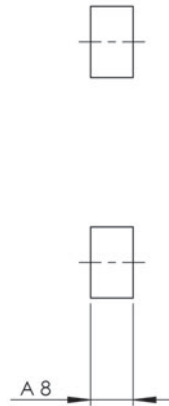
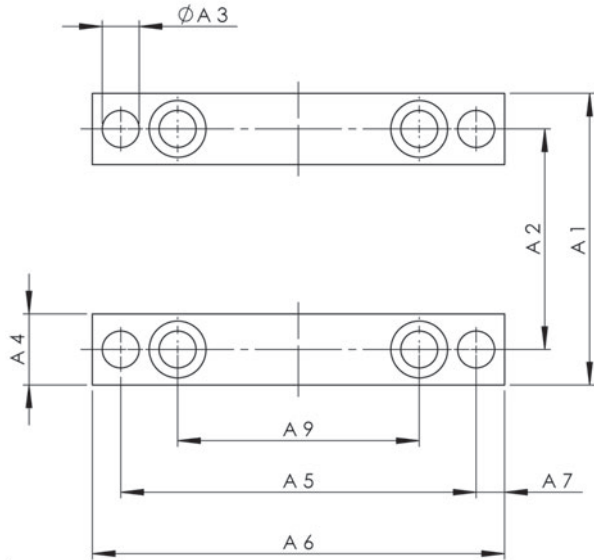

Size	Dimensions [mm]								Weight [kg]
	A_1	A_2	A_3	A_4	A_5	A_6	A_7	A_8	
LM 0	50	38	6.5	12	75	90	7.5	10	0.1
LM 1	72	52	8.5	20	100	120	10	10	0.3
LM 2	85	63	8.5	20	120	140	10	10	0.4
LM 3	105	81	11	24	150	170	10	12	0.8
LM 4	145	115	13.5	30	204	230	13	16	1.7
LM 5	171	131	22	40	236	270	17	25	3.9
LJ 1	205	155	26	50	250	290	20	30	5.8
LJ 2	230	170	32	65	290	340	25	40	10
LJ 3	230	170	32	65	290	340	25	40	10
LJ 4	270	190	39	80	350	410	30	50	20.8
LJ 5	330	230	45	100	430	500	35	60	34.4

Mountings

Universal joint adapter KA-ZL (lengthwise)

Supplied loose with mounting bolts for jack. Burnished.
Standard: side E. Side F please specify.

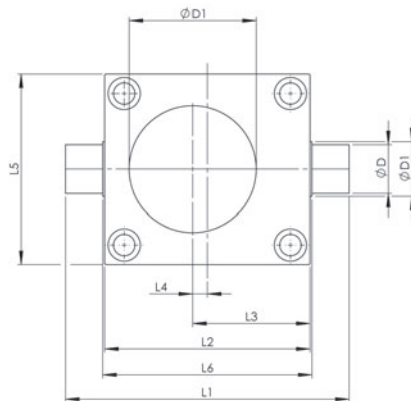
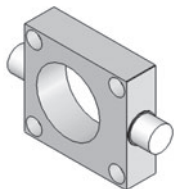

Lengthwise	L ₁	L ₂	L ₃	L ₄	L ₅	L ₆	Ø D _{fl}	Ø D ₁	Ø D ₂	B
M 1	80	60	38	8	50	64	10		13	15
M 1	110	80	49	9	72	84	15	44	18	20
M 2	140	100	60	10	85	104	20	58	23	25
M 3	170	130	76	11	105	134	25	72	28	30
M 4	240	180	102	12	145	184	35	86	38	40
M 5	270	200	117	17	165	204	45	115	48	50
J 1	290	210	120	15	195	214	50	130	56	60
J 2	330	240	140	20	220	244	70	170	76	80
J 3	330	240	140	20	220	244	70	170	76	80
J 4	410	290	165	20	250	294	80	160	88	90
J 5	520	360	210	30	300	364	90	175	96	100

Universal joint adapter KA-ZQ (crosswise)

Supplied loose with mounting bolts for jack. Burnished.
Standard: side E. Side F please specify.

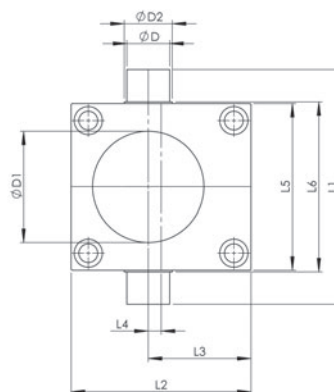
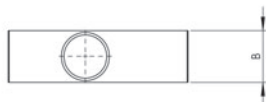
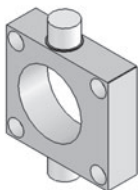

Crosswise	L ₁	L ₂	L ₃	L ₄	L ₅	L ₆	Ø D _{fl}	Ø D ₁	Ø D ₂	B
M 0	70	60	38	8	50	54	10		13	15
M 1	102	80	49	9	72	76	15	44	18	20
M 2	125	100	60	10	85	89	20	58	23	25
M 3	145	130	76	11	105	109	25	72	28	30
M 4	205	180	102	12	145	149	35	86	38	40
M 5	235	200	117	17	165	169	45	115	48	50
J 1	289	210	120	15	195	199	50	130	56	60
J 2	313	240	140	20	220	224	70	170	76	80
J 3	313	240	140	20	220	224	70	170	76	80
J 4	370	290	165	20	250	254	80	160	88	90
J 5	460	360	210	30	300	304	90	175	96	100

Universal joint bearings

Universal joint bearing flange

for mounting a universal joint adaptor or a universal joint bearing.

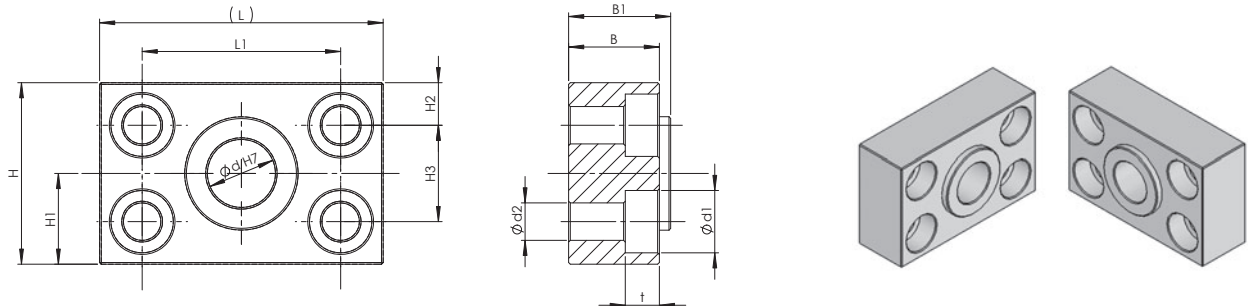

Size	Ø d ^{H7}	Ø d ₁	Ø d ₂	t	B	B ₁	H	H ₁	H ₂	H ₃	L	L ₁
KLF-0	10	11	6.6	6.8	15	16	32	16	7.5	17	50	35
KLF-1	15	15	9	9	19	21	36	18	9	18	65	45
KLF-2	20	15	9	9	19	21	40	20	10	20	70	50
KLF-3	25	18	11	11	19	21	54	27	12	30	80	58
KLF-4	35	20	13.5	13	30	32	70	35	15	40	100	70
KLF-5	45	33	22	21.5	39	41	80	40	20	40	140	100
KLF-200	70	48	33	32	49	51	125	62.5	30	65	220	160
KLF-300	80	57	39	38	62	66	144	72	34	76	245	180
KLF-400	80	57	39	38	62	66	144	72	34	76	245	180
KLF-500	90	66	45	44	80	82	160	80	40	80	28	200

Universal joint bearing pedestal

for mounting a universal joint adaptor or a universal joint bearing.

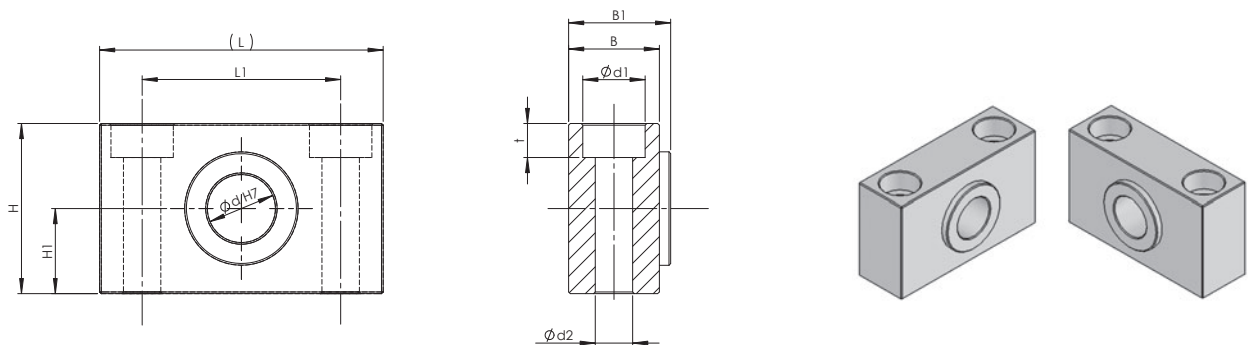

Size	Ø d ^{H7}	Ø d ₁	Ø d ₂	t	B	B ₁	H	H ₁	L	L ₁
KLB-0	10	11	6.6	6.8	16	18	30	15	50	35
KLB-1	15	15	9	9	20	22	34	17	65	45
KLB-2	20	15	9	9	20	22	38	19	70	50
KLB-3	25	18	11	11	20	22	54	27	80	58
KLB-4	35	20	13.5	13	30	32	70	35	100	70
KLB-5	45	33	22	21.5	40	42	80	40	140	100
KLB-200	70	48	33	32	63	64.5	124	62	220	160
KLB-300	80	57	39	38	63	64	144	72	245	180
KLB-400	80	57	39	38	63	64	144	72	245	180
KLB-500	90	66	45	44	80	82	160	80	28	200

Attachments

Top plate BP

Screwed onto the mounting thread of the jack screw and protected against rotation.

Standard: Hole-pattern BP symmetrically to SHG housing.

Note: Please specify alignment at version V.

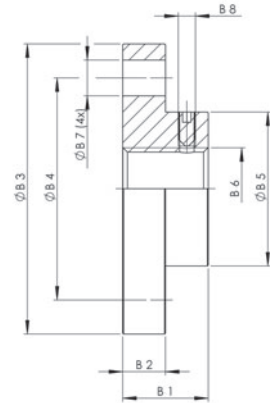

Size	Dimensions [mm]								Weight [kg]
	B ₁	B ₂	Ø B ₃	B ₄	B ₅	B ₆	B _{7x4}	B ₈	
BP M 0	16	6	50	40	26	M8	7	M4	0.1
BP M 1	20	7	65	48	29.3	M12	9	M5	0.2
BP M 2	21	8	80	60	38.7	M14	11	M6	0.3
BP M 3	23	10	90	67	46	M20	11	M8	0.6
BP M 4	30	15	110	85	60	M30	13	M8	1.2
BP M 5	50	20	150	117	85	M36	17	M10	4.8
BP J 1	50	25	170	130	90	M48 x 2	21	M10	5
BP J 2	60	30	200	155	105	M56 x 2	25	M12	7.7
BP J 3	60	30	220	170	120	M64 x 3	25	M12	9.8
BP J 4	80	40	260	205	145	M72 x 3	32	M12	18.4
BP J 5	120	40	310	240	170	M100 x 3	38	M12	29.6

Fork end GK

Screwed onto the mounting thread of the jack screw and protected against rotation. Supplied with split pins and collar pins.

Standard: Collar pin mounted parallel to the drive shaft.

Note: Please specify alignment at version V.

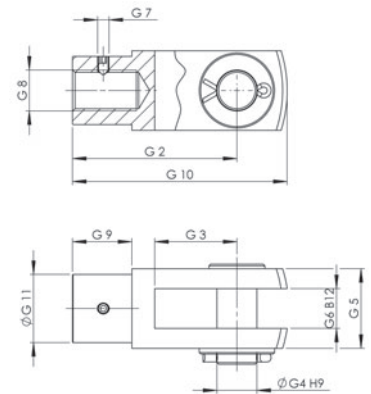
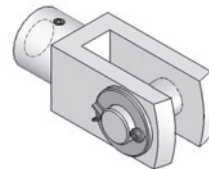

Size	Dimensions [mm]										Weight [kg]
	G ₂	G ₃	G ₄ H9	G ₅ k	G ₆ B12	G ₇	G ₈	G ₉	G ₁₀	G ₁₁	
GK M 0	32	16	8	16	8	M4	M8	12	42	14	0.04
GK M 1	48	24	12	24	12	M5	M12	18	62	20	0.15
GK M 2	56	28	14	28	14	M6	M14	22	72	24.5	0.2
GK M 3	80	40	20	40	20	M8	M20	30	105	34	0.8
GK M 4	120	60	30	60	30	M8	M30	43	160	52	2.5
GK M 5	144	72	35	70	35	M10	M36	54	188	60	3.8

Attachments

Clevis end GA

Screwed onto the mounting thread of the jack screw and protected against rotation.

Standard: Position of the cross hole parallel to drive shaft.

Note: Please specify alignment at version V.

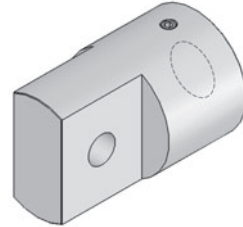
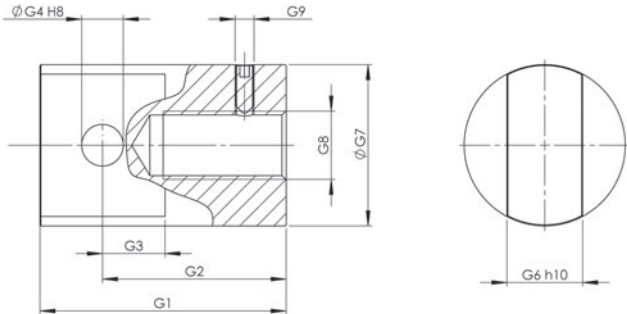

Size	Dimensions [mm]								Weight [kg]
	G ₁	G ₂	G ₃	G ₄ H8	G ₆ H10	G ₇	G ₈	G ₉	
GA M 0	40	30	10	8	12	25	M8	M4	0.1
GA M 1	55	40	15	10	15	30	M12	M5	0.2
GA M 2	63	45	18	12	20	39	M14	M6	0.3
GA M 3	78	53	20	16	30	45	M20	M8	0.6
GA M 4	100	70	30	20	35	60	M30	M8	1.2
GA M 5	130	97	33	22	40	85	M36	M10	2.5
GA J 1	120	75	45	40	60	90	M48 x 2	M10	4.8
GA J 2	130	90	50	50	70	105	M56 x 2	M12	4.8
GA J 3	155	105	60	60	80	120	M64 x 3	M12	8.0
GA J 4	220	135	85	80	110	145	M72 x 3	M12	22.5
GA J 5	300	200	100	90	120	170	M100 x 3	M12	31.5

High-performance joint head HG

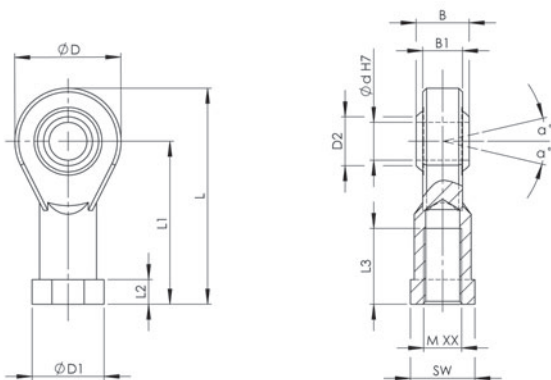

Dimensions	Ød ^{H7}	M	B	B1	D	D1	D2	L	L1	L2	L3	SW	Co / (KN)	Angle (°)	Weight
HG-0	10	M 10	14	10.5	28	19	12.9	57	43	6.5	20	17	17.65	13	0.076
HG-1	12	M 12	16	12	32	22	15.4	66	50	6.5	22	19	20.6	13	0.115
HG-2	14	M 14	19	13.5	36	25	16.8	75	57	8	25	22	29.4	15	0.17
HG-3	20	M 20x1.5	25	18	50	34	24.3	102	77	10	33	32	49.1	15	0.415
HG-4	30	M 30x2	37	25	70	50	34.8	145	110	15	51	41	99.1	15	1.13
HG-5	35	M 36x2	43	28	80	58	37.7	165	125	17	65	50	125	15	1.6
HG-6	70	M 56x4	49	42	160	98	92	280	200	20	80	85	630	6	8.4

Spiral spring cover SF

Spiral spring cover for protection against ambient influences. Suitable for horizontal and vertical installation position.

Material: Tempered spring band steel.

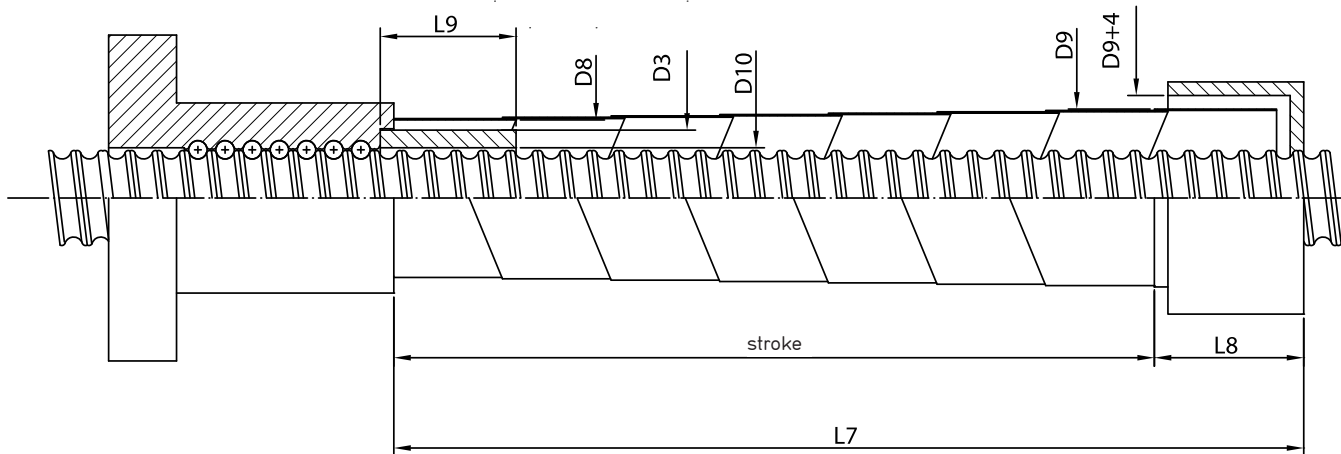

For KGT 1605

$D_3 = 22$ mm
 $D_{10} = 16,8$ mm
 $L_9 = 20$ mm

Type D_9 /stroke/ L_8	$L_{7v}^{1)}$	$L_{7h}^{2)}$	D_9
SF 25/100/20	100	60	35
SF 25/150/20	150	110	38
SF 25/200/20	200	160	40
SF 25/250/20	250	210	44
SF 25/300/30	300	240	43
SF 25/350/30	350	290	46
SF 25/400/30	400	340	49
SF 25/450/40	450	370	48
SF 25/500/40	500	420	51

For KGT 2005 KGT 2020 (KGT 2505)

$D_3 = 26$ (31) mm
 $D_{10} = 20,8$ (25,8) mm
 $L_9 = 28$ (28) mm

Type D_9 /stroke/ L_8	$L_{7v}^{1)}$	$L_{7h}^{2)}$	D_9
SF 30/150/30	150	90	39
SF 30/250/30	250	190	44
SF 30/350/30	350	290	49
SF 30/450/40	450	370	53
SF 30/550/40	550	470	58
SF 30/650/50	650	550	55
SF 30/750/50	750	650	59

For KGT 3205 KGT 3240

$D_3 = 38$ mm
 $D_{10} = 33$ mm
 $L_9 = 35$ mm

Type D_9 /stroke/ L_8	$L_{7v}^{1)}$	$L_{7h}^{2)}$	D_9
SF 40/150/30	150	90	51
SF 40/250/30	250	190	56
SF 40/350/30	350	290	60
SF 40/450/40	450	370	63
SF 40/550/40	550	470	68
SF 40/350/50	350	250	55
SF 40/450/50	450	350	58
SF 40/550/50	550	450	61
SF 40/650/50	650	550	65
SF 40/750/50	750	650	69
SF 40/450/60	450	330	55
SF 40/550/60	550	430	58
SF 40/650/60	650	530	62
SF 40/750/60	750	630	66

For KGT 3205 KGT 3240

$D_3 = 38$ mm
 $D_{10} = 33$ mm
 $L_9 = 35$ mm

Type D_9 /stroke/ L_8	$L_{7v}^{1)}$	$L_{7h}^{2)}$	D_9
SF 40/900/60	900	780	70
SF 40/650/75	650	500	62
SF 40/750/75	750	600	66
SF 40/900/75	900	750	72
SF 40/1100/78	1100	950	78
SF 40/1300/75	1300	1150	84
SF 40/1500/75	1500	–	90
SF 40/1000/100	1000	800	66
SF 40/1200/100	1200	1000	70
SF 40/1500/100	1500	1300	78
SF 40/1800/100	1800	–	82
SF 40/1800/120	1800	1560	82
SF 40/2000/120	2000	1760	86
SF 40/2200/120	2200	–	91

¹⁾ $L_{7v} = L_7$ vertical installation
²⁾ $L_{7h} = L_7$ horizontal installation

Spiral spring cover SF

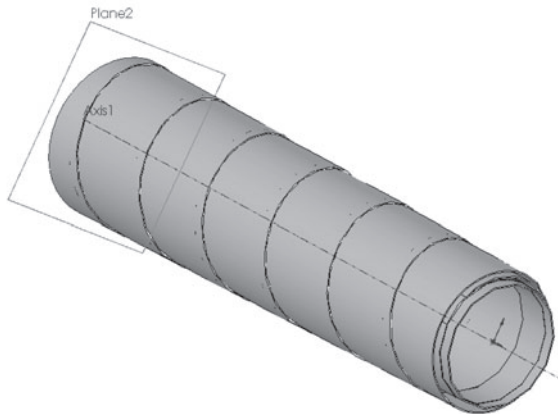

For KGT 4005 (KGT 3210)

$D_3 = 46$ (44) mm
 $D_{10} = 41$ (34) mm
 $L_9 = 45$ (45) mm

Type D_8 /stroke/ L_8	$L_{7v}^{1)}$	$L_{7h}^{2)}$	D_9
SF 50/150/30	150	90	63
SF 50/250/30	250	190	68
SF 50/250/50	250	150	62
SF 50/350/50	350	250	66
SF 50/450/50	450	350	70
SF 50/550/50	550	450	73
SF 50/550/60	550	430	68
SF 50/650/60	650	530	72
SF 50/750/60	750	630	76
SF 50/750/75	750	600	78
SF 50/900/75	900	750	84
SF 50/1100/75	1100	950	90
SF 50/1100/50	1100	900	75
SF 50/1300/100	1300	1100	79
SF 50/1500/100	1500	1300	83
SF 50/1700/120	1700	1460	91
SF 50/1800/120	1800	–	94
SF 50/1900/120	1900	1660	95
SF 50/2100/120	2100	1860	100
SF 50/2300/120	2300	–	105
SF 50/2500/120	2500	–	111
SF 50/2800/120	2800	–	118
SF 50/2800/150	2800	2500	118
SF 50/3000/150	3000	–	123
SF 50/3000/180	3000	2640	123
SF 50/3250/180	3250	–	128
SF 50/3250/200	3250	2850	128
SF 50/3250/200	3250	–	134

For KGT 4010

$D_3 = 52$ mm
 $D_{10} = 41$ mm
 $L_9 = 50$ mm

Type D_8 /stroke/ L_8	$L_{7v}^{1)}$	$L_{7h}^{2)}$	D_9
SF 55/150/30	150	90	68
SF 55/250/30	250	190	73
SF 55/250/50	250	150	66
SF 55/350/50	350	250	71
SF 55/450/50	450	350	74
SF 55/550/50	550	450	77
SF 55/550/60	550	430	75
SF 55/650/60	650	530	79
SF 55/750/60	750	630	83
SF 55/750/75	750	600	83
SF 55/900/75	900	750	89
SF 55/1100/75	1100	950	94
SF 55/1100/100	1100	900	83
SF 55/1300/100	1300	1100	87
SF 55/1500/100	1500	1300	94
SF 55/1800/120	1800	–	102
SF 55/1700/120	1700	1460	96
SF 55/1900/120	1900	1660	100
SF 55/2100/120	2100	1860	105
SF 55/2300/120	2300	2060	110
SF 55/2500/120	2500	–	116
SF 55/2800/150	2800	2500	121
SF 55/2800/120	2800	–	123
SF 55/3000/150	3000	2640	126
SF 55/3000/180	3000	–	126
SF 55/3250/180	3250	2850	130
SF 55/3250/200	3250	–	130
SF 55/3250/200	3250	–	137

For KGT 5010

$D_3 = 62$ mm
 $D_{10} = 51,2$ mm
 $L_9 = 55$ mm

Type D_8 /stroke/ L_8	$L_{7v}^{1)}$	$L_{7h}^{2)}$	D_9
SF 65/250/30	250	90	85
SF 65/250/50	250	150	76
SF 65/350/50	350	250	83
SF 65/450/50	450	350	88
SF 65/550/60	550	430	88
SF 65/650/60	650	530	92
SF 65/750/60	750	630	95
SF 65/750/75	750	600	93
SF 65/900/75	900	750	99
SF 65/1100/75	1100	950	107
SF 65/1100/100	1100	900	95
SF 65/1300/100	1300	1100	99
SF 65/1500/100	1500	1300	108
SF 65/1700/120	1700	1460	106
SF 65/1800/100	1800	–	117
SF 65/1900/120	1900	1660	109
SF 65/2100/120	2100	1860	113
SF 65/2300/120	2300	2060	118
SF 65/2500/150	2500	–	132
SF 65/2800/120	2800	–	128
SF 65/2800/150	2800	–	132
SF 65/3000/150	3000	–	142
SF 65/3000/180	3000	–	136
SF 65/3250/180	3250	–	145
SF 65/3250/200	3250	2850	138

For KGT 6310

$D_3 = 74$ mm
 $D_{10} = 63,2$ mm
 $L_9 = 65$ mm

Type D_8 /stroke/ L_8	$L_{7v}^{1)}$	$L_{7h}^{2)}$	D_9
SF 75/250/30	250	190	99
SF 75/250/50	250	150	89
SF 75/350/50	350	250	94
SF 75/450/50	450	350	101
SF 75/550/60	550	430	99
SF 75/650/60	650	530	103
SF 75/750/60	750	630	108
SF 75/650/75	650	500	99
SF 75/750/75	750	600	104
SF 75/900/75	900	750	111
SF 75/1100/100	1100	900	108
SF 75/1300/100	1300	1100	112
SF 75/1500/100	1500	1300	120
SF 75/1500/120	1500	1260	115
SF 75/1700/100	1700	–	126
SF 75/1800/120	1800	1560	122
SF 75/2000/120	2000	1760	127
SF 75/2200/120	2200	–	132
SF 75/2000/150	2000	1700	135
SF 75/2400/150	2400	2100	141
SF 75/2800/150	2800	–	145
SF 75/2800/180	2800	2440	142
SF 75/3000/180	3000	–	148
SF 75/3250/180	3250	–	156
SF 75/3250/200	3250	2850	148
SF 75/3500/200	3500	–	158

¹⁾ $L_{7v} = L_7$ vertical installation
²⁾ $L_{7h} = L_7$ horizontal installation

3-phase motors M

3-phase 4-pole motors (1500 rpm) in totally enclosed fan-cooled designs in accordance with VDE 0530 Part 1.

Standard degree of protection: IP55. Temperature class F. Other SEW motors on request.

Notes: If the free shaft end of the motor is used as shaft for a slip-on emergency hand wheel, a device will be required which interrupts the power supply before the crank engages. Motors with different speeds and brake motors on request.

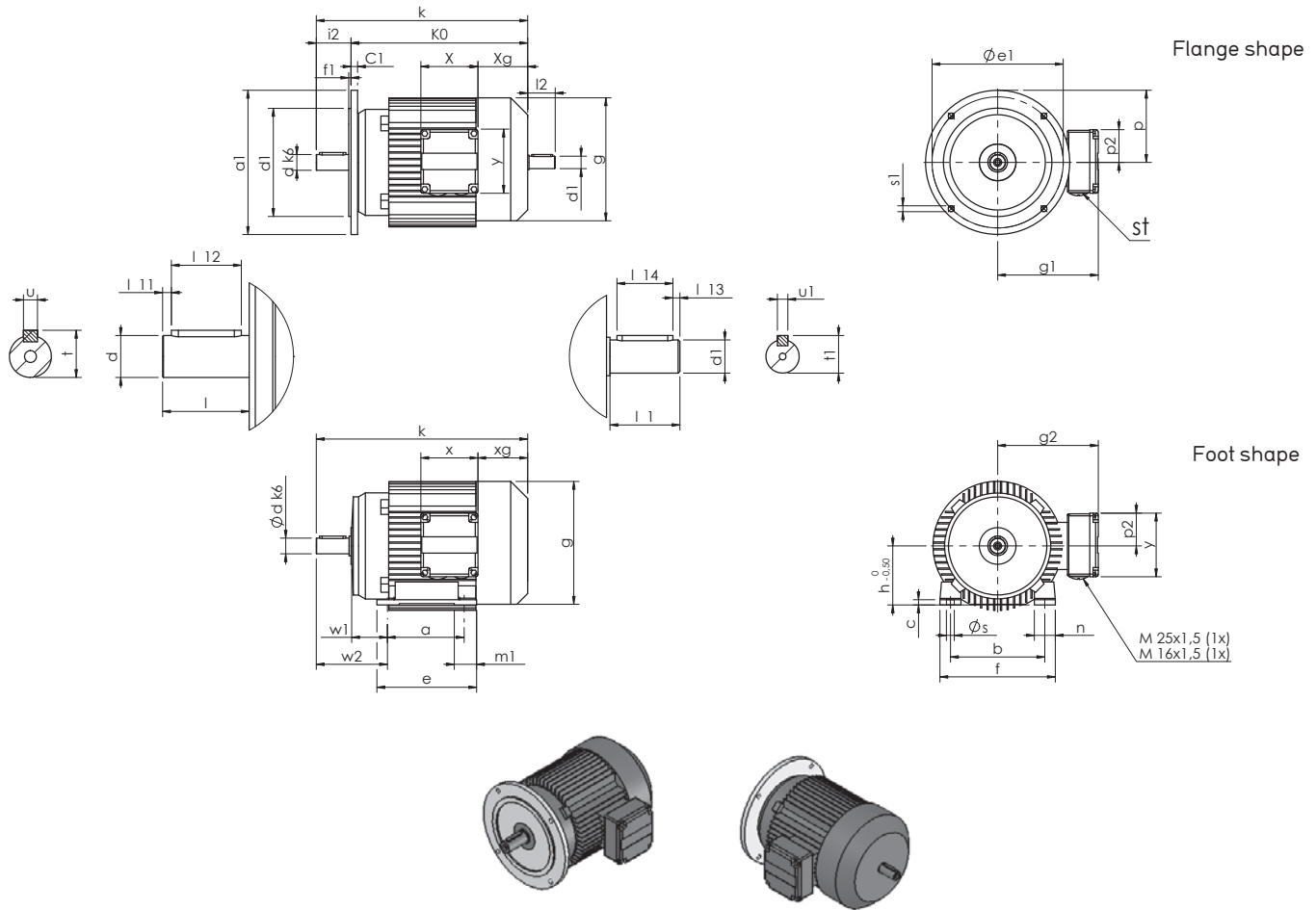

Performance data

Size	Nominal power [kW]	Nominal speed [rpm]	Power factor $\cos \varphi$	Nominal current at 400 V [A]	Rel. locked-rotor current I_A/I_N	Nominal moment [Nm]	Rel. locked-rotor torque M_A/M_N	Rel. Run-up moment M_H/M_N	Rotor inertia J_{Mot} [10^{-4}kgm^2]	Rotor inertia $J_{Brakemotor}$ [10^{-4}kgm^2]	Braking moment [Nm]
DT71K4	0.15	1380	0.67	0.61	2.9	1.0	1.8	1.7	4.6	5.5	5.0
DT71C4	0.25	1380	0.70	0.80	2.8	1.7	1.8	1.7	4.6	5.5	5.0
DT71D4	0.37	1380	0.76	1.15	3.0	2.6	1.8	1.7	4.6	5.5	5.0
DT80K4	0.55	1360	0.72	1.75	3.4	3.9	2.1	1.8	7.5	7.5	10
DT80N4	0.75	1380	0.73	2.1	3.8	5.2	2.2	2.0	8.7	9.6	10
DT90S4	1.1	1400	0.77	2.8	4.3	7.5	2.0	1.9	25	31	20
DT90L4	1.5	1410	0.78	3.55	5.3	10.2	2.6	2.3	34	40	20
DV100M4	2.2	1410	0.83	4.7	5.9	15.0	2.7	2.3	53	59	40
DV100L4	3.0	1400	0.83	6.3	5.6	20.5	2.7	2.2	65	71	40
DV112M4	4.0	1420	0.84	8.7	5.4	26.9	2.4	2.1	98	110	55

3-phase motors M

Dimensions

The values in brackets refer to motors with brake.

Flange shape

Size	Dimensions [mm]													
	a ₁	b ₁	c ₁	d	d ₁	e ₁	f ₁	g	g ₁	i ₂	k	k ₀	l	l ₁₁
DFT71K4	120	80	8	14	11	100	3	145	122(127)	24	232 (296)	208 (296)	30	4
DFT71C4	120	80	8	14	11	100	3	145	122(127)	24	232 (296)	208 (272)	30	4
DFT71D4	120	80	8	14	11	100	3	145	122(127)	24	232 (296)	208 (272)	30	4
DFT80K4	120	80	8	19	14	100	3	145	122(127)	34	292 (356)	258 (322)	40	4
DFT80N4	120	80	8	19	14	100	3	145	122(127)	34	292 (356)	258 (322)	40	4
DFT90S4	160	110	10	24	19	130	3.5	197	154(161)	53.5	323 (408)	273 (358)	50	5
DFT90L4	160	110	10	24	19	130	3.5	197	154(161)	53.5	323 (408)	273 (358)	50	5
DFV100M4	200	130	10	28	19	165	3.5	197	166	60	371 (456)	311 (396)	60	5
DFV100L4	200	130	10	28	19	165	3.5	197	166	60	401 (486)	341 (426)	60	5
DFV112M4	200	130	11	28	24	165	3.5	221	179(182)	64	409 (489)	345 (425)	60	5

Size	Dimensions [mm]													
	l ₁₂	l ₁	l ₂	l ₁₃	l ₁₄	s ₁	t	u	t ₁	u ₁	x	x _g	y	p ₂
DFT71K4	22	23	24	1	20	6.6	16	5	12.5	4	87 (127)	61 (86)	97	50
DFT71C4	22	23	24	1	20	6.6	16	5	12.5	4	87 (127)	61 (86)	97	50
DFT71D4	22	23	24	1	20	6.6	16	5	12.5	4	87 (127)	61 (86)	97	50
DFT80K4	32	30	31	4	22	6.6	21.5	6	16	5	87 (127)	61 (86)	97	50
DFT80N4	32	30	31	4	22	6.6	21.5	6	16	5	87 (127)	61 (86)	97	50
DFT90S4	40	40	42	4	32	9	27	8	21.5	6	87 (127)	76 (121)	97	50
DFT90L4	40	40	42	4	32	9	27	8	21.5	6	87 (127)	76 (121)	97	50
DFV100M4	50	40	42	4	32	11	31	8	21.5	6	106 (139)	74 (125)	109	56
DFV100L4	50	40	42	4	32	11	31	8	21.5	6	106 (139)	74 (125)	109	56
DFV112M4	50	50	55	5	40	11	31	8	27	8	106 (139)	91 (131)	109	56

Foot shape

Size	Dimensions [mm]											
	a	b	c	e	f	h	m ₁	n	s	w ₁	w ₂	
DT71K4	90	112	5	115	144	71	32	31	7	45	75	
DT71C4	90	112	5	115	144	71	32	31	7	45	75	
DT71D4	90	112	5	115	144	71	32	31	7	45	75	
DT80K4	100	125	10	125	149	80	28	33	9	50	90	
DT80N4	100	125	10	125	149	80	28	33	9	50	90	
DT90S4	125	140	8	152	176	90	32	32	9	56	106	
DT90L4	125	140	8	152	176	90	32	32	9	56	106	
DV100M4	140	160	12	170	188	100	35	38	12	63	123	
DV100L4	140	160	12	170	188	100	35	38	12	63	123	
DV112M4	140	190	14	170	220	112	35	44	12	70	130	

Motor adapter flanges MG

Motor adapter flanges are used to mount motors to worm gear screw jacks and house the coupling for connecting the motor to the drive shaft.

When ordering, please specify the side to which the motor adapter flange is to be attached (A or B).

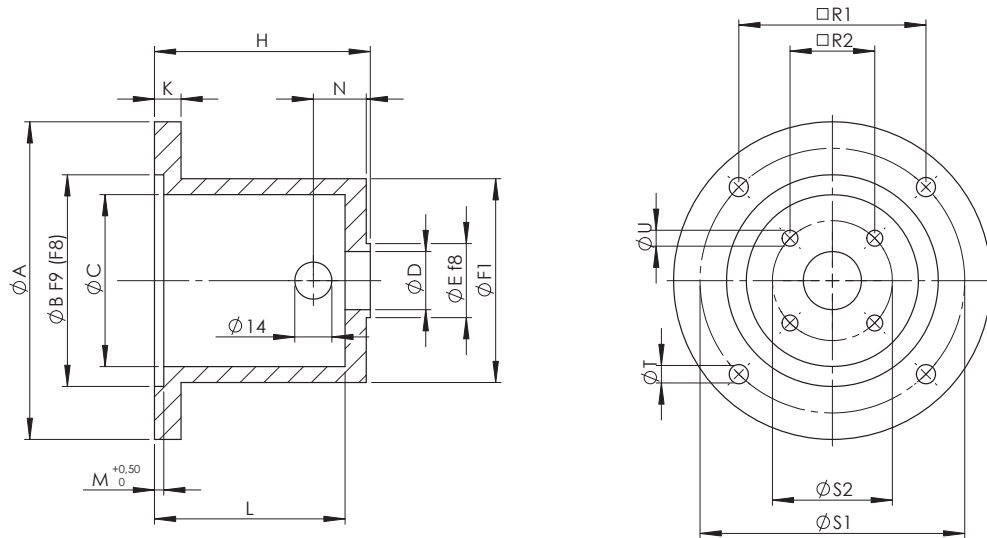

Size	Motor	Design MG/ZF ¹⁾	Dimensions [mm]									
			A	B	C	D	E	Ø F	□ F	H	I	K
MG M 0	DFT63	MG	90	60	44	19	22	50		62	61	10
MG M 1	DFT71	MG	120	80	65	22	28	77		81.5	80	10
MG M 1	DFT80	MG	120	80	56	22	28	62		91.5	90	10
MG M 2	DFT71	MG	120	80	65	26	35	77		81.5	80	10
MG M 2	DFT80	MG	120	80	78	26	35	88		92.5	91	10
MG M 2	DFT90	MG	160	110	90	31	35	110		109.5	108	15
MG M 3	DFT71	MG	120	80	77	28	35	87		91.5	90	10
MG M 3	DFT80	MG	120	80	78	28	35	88		103	101	10
MG M 3	DFT90	MG	160	110	95	28	35	104		125	123	12
MG M 3	DFV100/112	MG + ZF	200	130	100	24	35	145		133	131	29
MG M 4	DFT80	MG	120	80	75	42	52	–	88	105	103	12
MG M 4	DFT90	MG	160	110	98	42	52	114		118	116	15
MG M 4	DFV100/112	MG + ZF	200	130	120	30	52	145		134	131	29
MG M 5	DFT90	MG	160	110	105	45	52	120		138.5	136	15
MG M 5	DFV100/112	MG	200	130	125	35	52	145		154	152	16

¹⁾ MG = Motor adapter flange
ZF = Intermediate flange

Motor adapter flanges MG

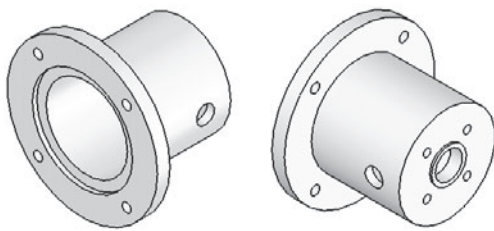

Dimensions [mm]									Coupling Size	Coupling half ¹⁾ M	Coupling half ¹⁾ Motor
L	M	N	□ R ₁	□ R ₂	S ₁	S ₂	T	U			
53	3	20	53	24	75	33.9	6	5.5	RA14	RA14 Ø9	RA14 Ø11
72	3.5	20	70.7	32	100	45.3	6.6	5.5	RA19	RA19 Ø10	RA19 Ø14
85	3.5	20	70.7	32	100	45.3	6.6	5.5	RA19	RA19 Ø10	RA19 Ø19
73	3.5	22	70.7	35	100	49.5	6.6	6.6	RA19	RA19 Ø14	RA19 Ø14
84	3.5	22	70.7	35	100	49.5	6.6	6.6	RA19	RA19 Ø14	RA19 Ø19
100	4	27	92	35	130	49.5	9	6.6	RA24	RA24 Ø14	RA24 Ø24
83	3.5	27	70.7	44	100	62.2	6.6	9	RA19	RA19 Ø16	RA19 Ø14
93	3.5	32	70.7	44	100	62.2	6.6	9	RA19	RA19 Ø16	RA19 Ø19
114	4	30	92	44	130	62.2	9	9	RA24	RA24 Ø16	RA24 Ø24
119	4.5	40	116.7	44	165	62.2	M10	9	RA28	RA28 Ø16	RA28 Ø28
94	3.5	35	70.7	55	100	78	6.6	11	RA24	RA24 Ø20	RA24 Ø19
106	4	30	92	55	130	78	M8	11	RA24	RA24 Ø20	RA24 Ø24
119	4.5	38	116.7	55	165	78	M10	11	RA28	RA28 Ø20	RA28 Ø28
122	4	48	92	70	130	85	M8	13.5	RA28	RA28 Ø25	RA28 Ø24
138	7	50	116.7	70	165	85	M10	13.5	RA28	RA28 Ø25	RA28 Ø28

¹⁾ When ordering, specify explicitly the diameter of the hole drilling in the motor side of the coupling half.

Couplings

Shaft couplings GS

The GS shaft coupling is a special anti backlash shaft coupling.

The toothed ring is installed under pre-tension, resulting in a low surface pressure and hence increased rigidity of the system.

This shaft coupling has proved itself due to its flawless function and durability at high speeds and under strong acceleration.

We recommend this shaft coupling with clamping hub or clamping ring hub.

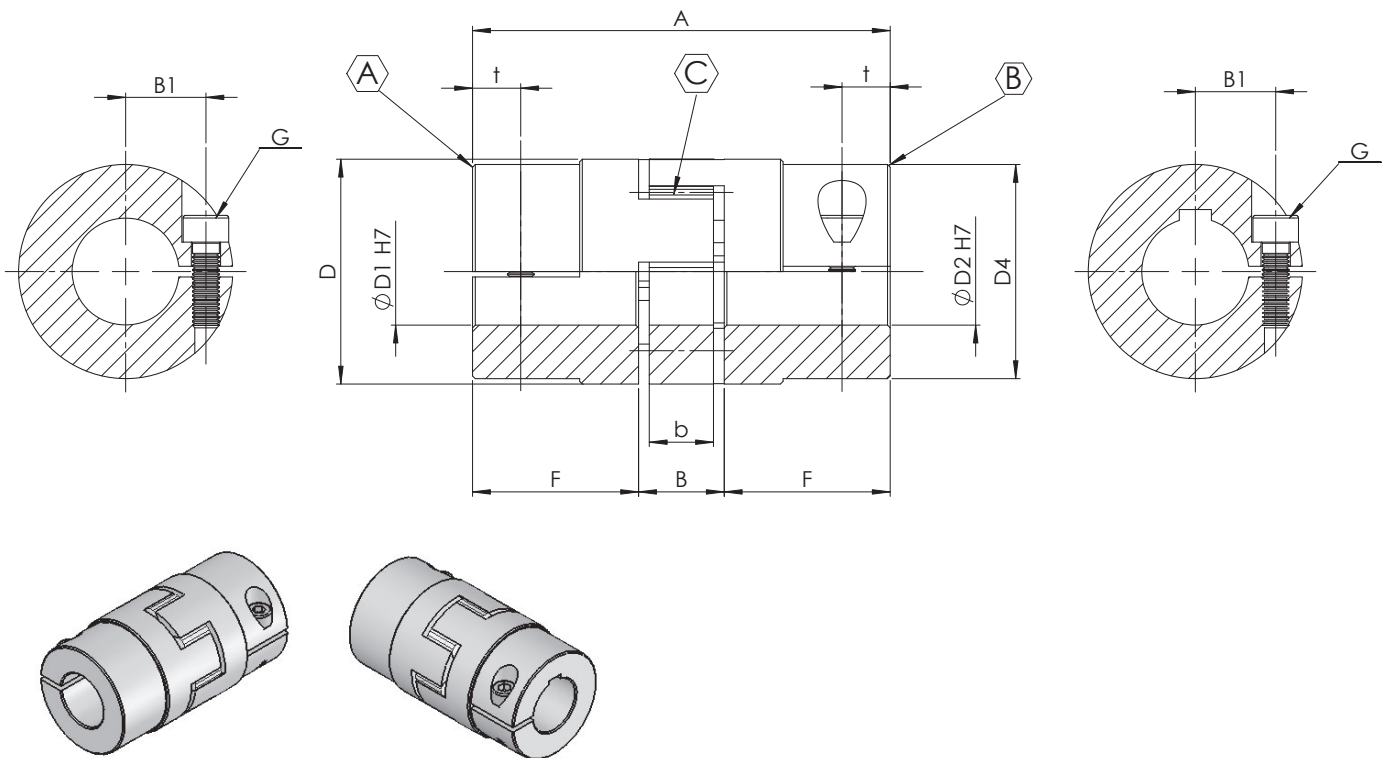

Size	D ₁	D ₂	D ₃	D ₄	A	F	t	b	B	B ₁	G
	H ⁷	H ⁷									
WK-GS-9	6-9	6-9	20	23.5	30	10	5	8	10	7.5	M2
WK-GS-14	6-14	6-14	30	32.5	35	11	5	10	13	11.5	M3
WK-GS-19	10-20	10-20	40	46	66	25	12	12	16	14.5	M6
WK-GS-24	10-28	10-28	55	57	78	30	14	14	18	14.5	M6
WK-GS-28	19-38	19-39	65	72.6	90	35	15	15	20	20	M8

Couplings

Shaft couplings RA, RG

The RA or RG shaft couplings are particularly torsionally flexible. They compensate smaller angular, radial and axial shaft displacements. They protect worm gear screw jacks, bevel gears and motors thanks to their shock and vibration damping effect.

Version 1

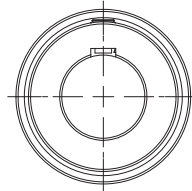
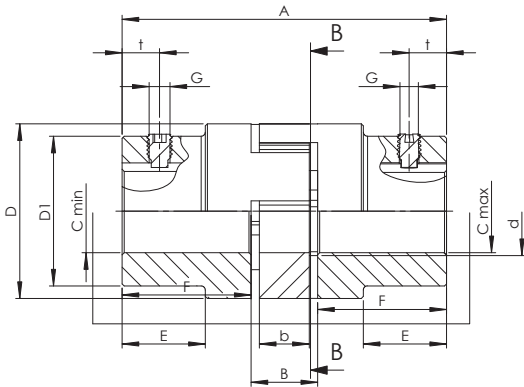

Version 1a

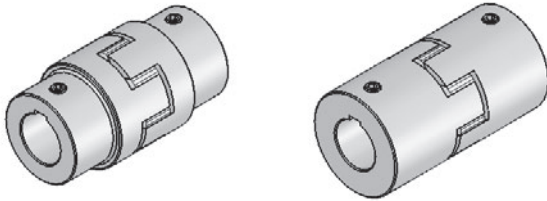
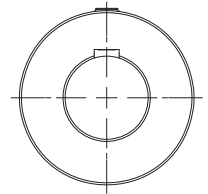
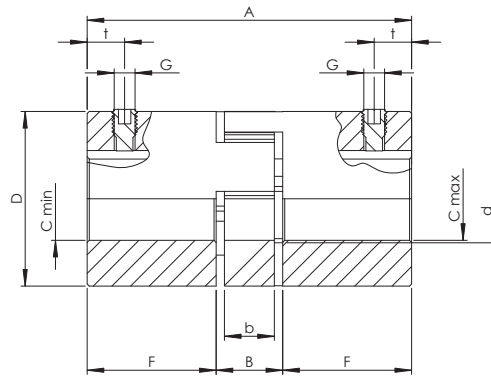

Size	Ver- sion	max. tor- que [Nm]	Dimensions [mm]										Offsets				Locking screw		Weight [kg]
			A ₁	E	F	B	b	D ₁	D	d	C _{min} ¹⁾	C _{max} ¹⁾	max. axial- stagger Δ Ka [mm]	max. radial non-alignment n=1500 rpm Δ Kr [mm]	max. angle stagger at n=1500 rpm Δ Kw [Grad] Δ Kw [mm]		Dim. G	Dim. t	
RA 14	1a	7.5	35	–	11	13	10	–	30	10	6	15	1.0	0.17	1.2	0.67	M4	5	0.05
RA 19	1	10	66	20	25	16	12	32	40	18	10	19	1.2	0.20	1.2	0.82	M5	10	0.15
RA 19	1a	10	66	–	25	16	12	–	41	18	19	24	1.2	0.20	1.2	0.82	M5	10	0.15
RA 24	1	35	78	24	30	18	14	40	55	27	14	24	1.4	0.22	0.9	0.85	M5	10	0.25
RA 24	1a	35	78	–	30	18	14	–	56	27	22	28	1.4	0.22	0.9	0.85	M5	10	0.35
RA 28	1	95	90	28	35	20	15	48	65	30	14	28	1.5	0.25	0.9	1.05	M6	15	0.40
RA 28	1a	95	90	–	35	20	15	–	67	30	28	38	1.5	0.25	0.9	1.05	M6	15	0.55
RG 38	1	190	114	37	45	24	18	66	80	38	16	38	1.8	0.28	1.0	1.35	M8	15	0.85
RG 42	1	265	126	40	50	26	20	75	95	46	28	42	2.0	0.32	1.0	1.70	M8	20	1.2
RG 48	1	310	140	45	56	28	21	85	105	51	28	48	2.1	0.36	1.1	2.00	M8	20	1.7
RG 55	1	410	160	52	65	30	22	98	120	60	30	55	2.2	0.38	1.1	2.30	M10	20	7.3
RG 65	1	625	185	61	75	35	26	115	135	68	40	65	2.6	0.42	1.2	2.70	M10	20	11.0
RG 75	1	975	210	69	85	40	30	135	160	80	40	75	3.0	0.48	1.2	3.30	M10	25	17.9
RG 90	1	2400	245	81	100	45	34	160	200	100	50	90	3.4	0.50	1.2	4.30	M12	30	28.5

¹⁾ This catalogue does not list all intermediate sizes.
Further sizes on request.

Universal joint shafts ZR

The ZR universal joint shaft is particularly torsionally flexible and serves to bridge large shaft distances at rotary speeds of up to 1500 rpm. Thanks to the double arrangement of the toothed rings, large radial displacements are possible with good damping characteristics. The ZR universal joint shaft can be mounted radially without shifting the gearbox or the motor.

Section B-B

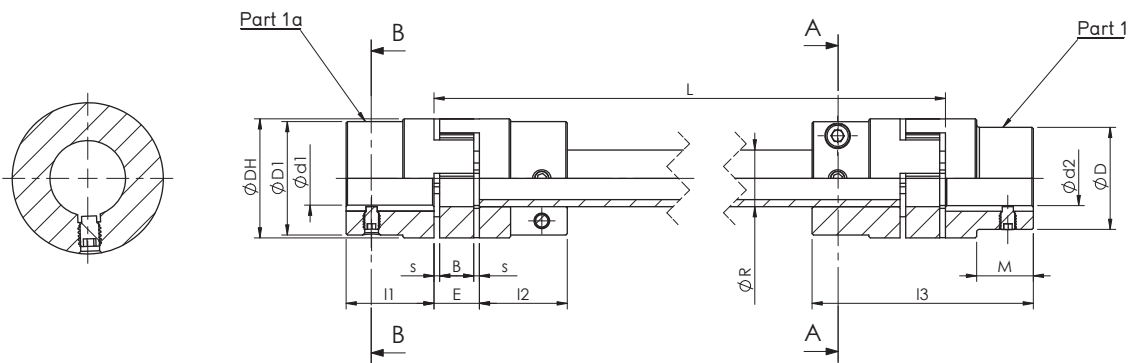

Section A-A

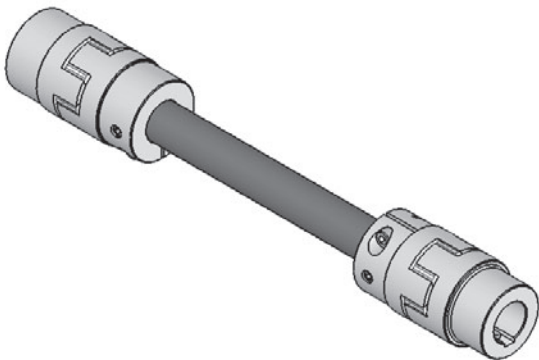
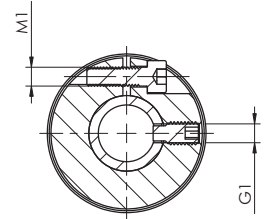

Size	Manufacturing bore $\text{ØdH7}^{2)}$				Ø DH	Ø D	Ø D1	ØdH	l1	l2	M	s	b	E	l3	ØR	G1	dp
	Part 1	Part 1a	min Ød2	max Ød1														
ZR 14	-	-	4	14	30	-	30	10.5	11	-	1.5	10	13	35	14x2	M4	2.5	
ZR 19	6	19	19	24	40	32	41	18	25	20	2	12	16	66	20x3	M6	4	
ZR 24	8	24	24	28	55	40	55	27	30	24	2	14	18	78	30x4	M8	5.5	
ZR 28	10	28	28	38	65	48	65	30	35	28	2.5	15	20	90	35x4	M10	7	
ZR 38	12	38	38	45	80	66	77	38	45	37	3	18	24	114	40x4	M12	8.5	
ZR 42	28	42	42	55	95	75	94	46	50	40	3	20	26	126	45x4	M12	8.5	
ZR 48	28	48	48	60	105	85	102	51	56	45	3.5	21	28	140	50x4	M16	12	

Universal joint shafts GX

Universal joint shafts are used to connect several worm gear screw jacks together. The shafts attenuate noise, vibrations and impacts and compensate for axial, radial and angular errors. They offer exceptional torsional rigidity, high temperature and oil resistance and are particularly suitable where long lengths and/or high speeds are a factor. Elastic universal joint shafts are maintenance-free; the central section can be removed radially (to the side) without axial displacement of the connected units.

They are supplied as a length of tube (dimension L to be specified by customer) fitted with coupling assemblies at both ends. Pillow blocks are generally not required, except for very long connections. For optimum alignment of the jack gear screws, we recommend the use of universal joint shafts with clamping sets.

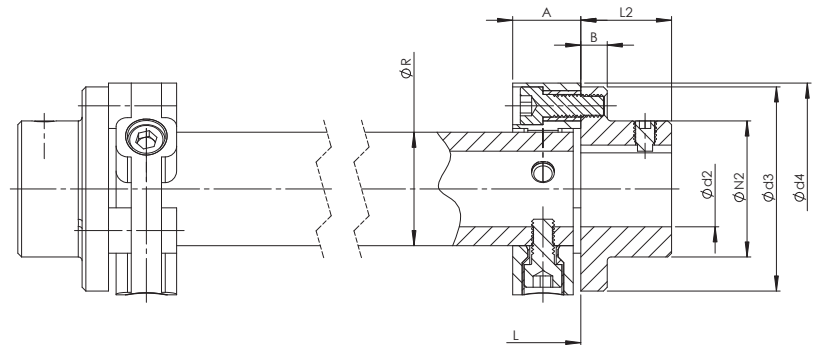
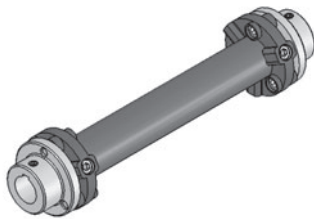

Size	A	B	C	$\varnothing d_3$	Pilot hole d	Manufacturing bore $\varnothing d_{H7 2}$ D max ⁽²⁾	E	F	L ₂	$\varnothing N_2$	$\varnothing R$	T	T _K / M
GX - 1	24	7	5	56	8	25	22	2	24	36	30	1.5	$\varnothing 44/2 \times M6$
GX - 2	24	8	5	85	12	38	20	4	28	55	40	1.5	$\varnothing 68/2 \times M8$
GX - 4	28	8	5	100	15	45	24	4	30	65	45	1.5	$\varnothing 80/3 \times M8$
GX - 8	32	10	5	120	18	55	28	4	42	80	60	1.5	$\varnothing 100/3 \times M10$
GX - 16	42	12	5	150	20	70	36	6	50	100	70	1.5	$\varnothing 125/3 \times M12$
GX - 25	46	14	5	170	20	85	40	6	55	115	85	1.5	$\varnothing 140/3 \times M14$
GX - 30	58	16	5	200	25	100	50	8	66	140	100	1.5	$\varnothing 165/3 \times M16$
GX - 50	58	16	5	200	25	100	50	8	66	140	100	1.5	$\varnothing 165/3 \times M16$
GX - 90	70	19	5	260	30	110	62	8	80	160	125	2	$\varnothing 215/3 \times M20$

Universal joint shaft diagram as a function of length and speed

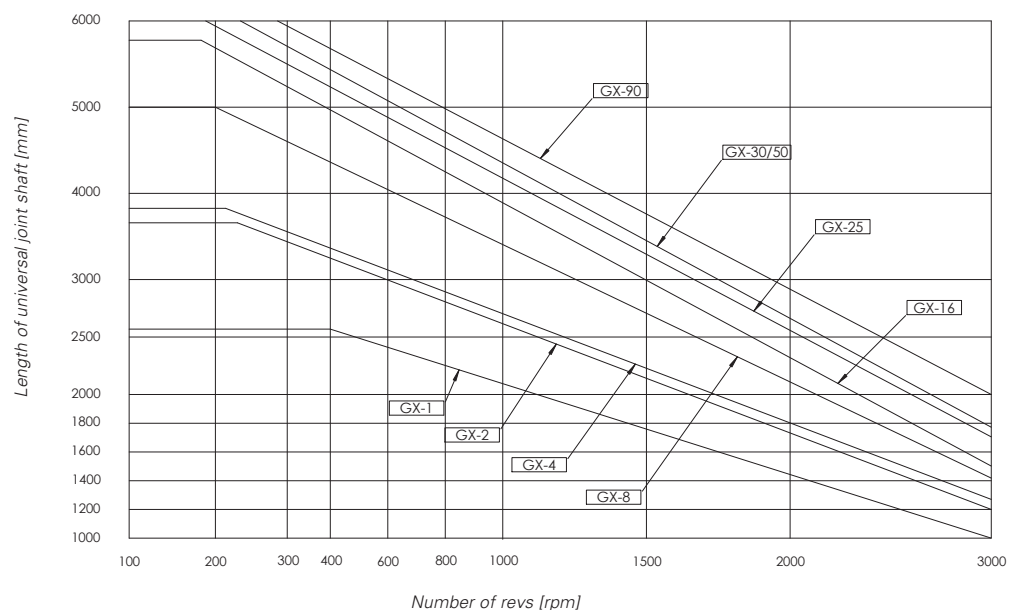

Universal joint shafts GX

Length of the universal joint shaft for
screw jacks M with feather key groove

M 0

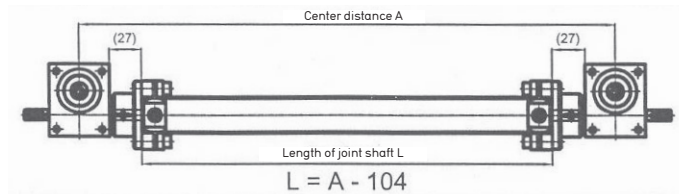

M 1

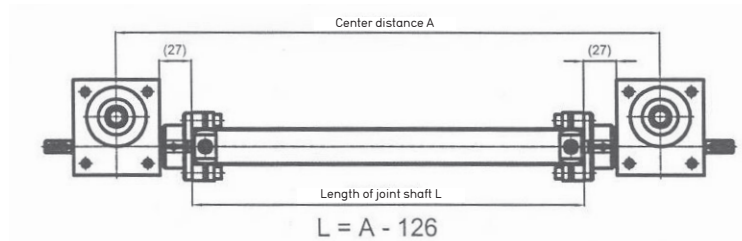

M 2

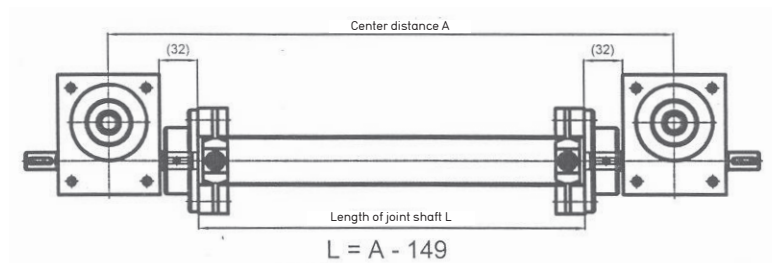

M 3

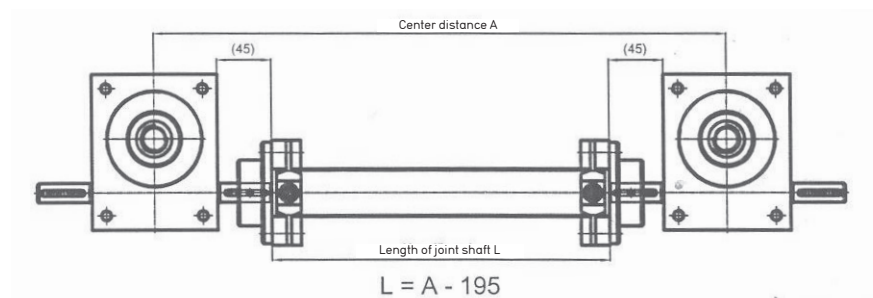

M 4

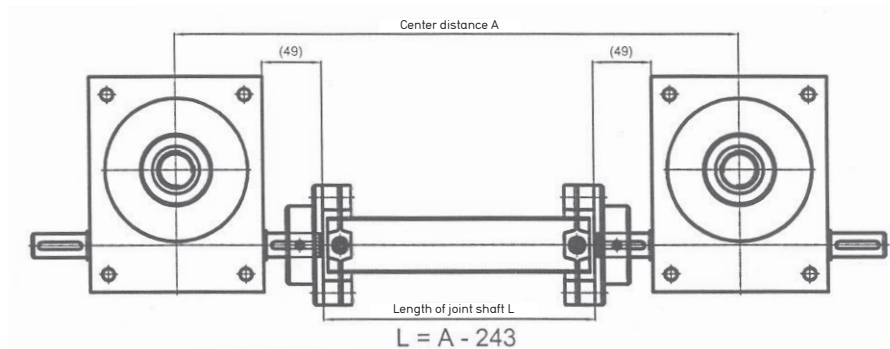

M 5

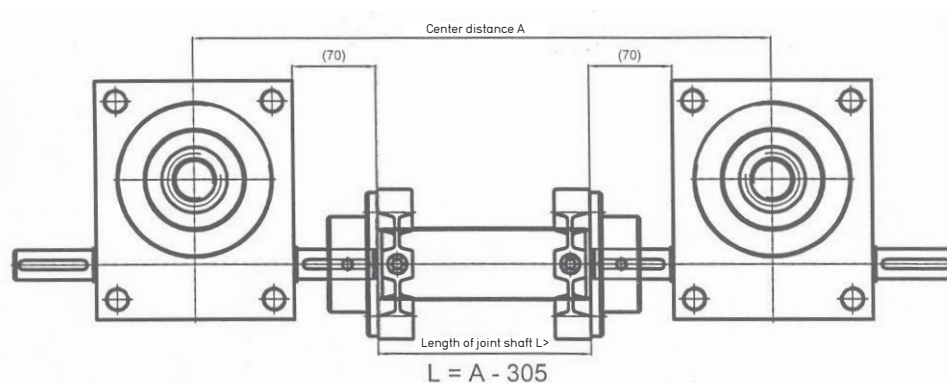

Pillow blocks SN

The pillow blocks conforming to DIN 736 come complete with roller bearing, retaining bush and case with felt seals on both sides. These pillow blocks are very well suited for the intermediate support of our GX and ZR universal joint shafts when these are very long. The retaining bush can be fixed to the outer diameter of the tube.

The pillow block is supplied as a movable bearing if nothing in particular is specified.

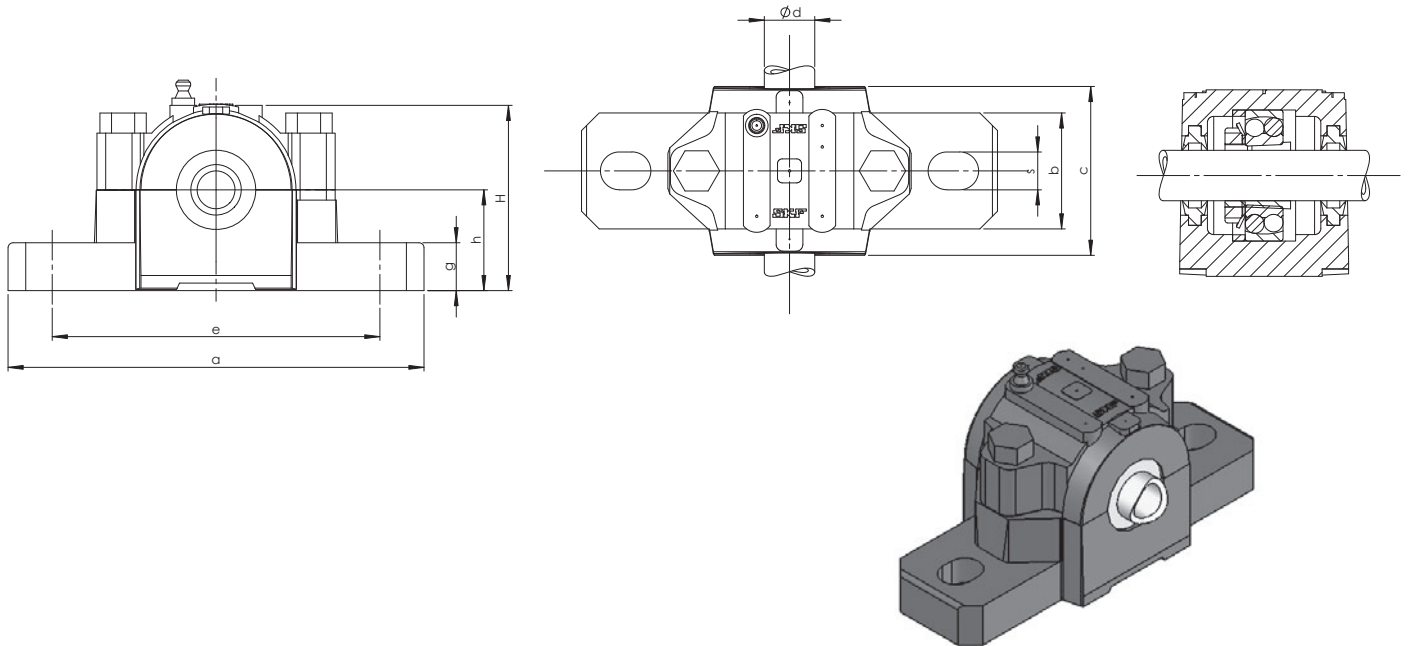

Size	Ø d	H	h	e	S	C	a	b	g (max)	Weight kg
SN 505-20	20	75	40	130	15	67	165	46	19	1.4
SN 506-25	25	90	50	150	15	77	185	52	22	1.98
SN 507-30	30	110	50	150	15	82	185	52	22	2.1
SN 508-35	35	110	60	170	15	85	205	60	25	3.1
SN 509-40	40	115	60	170	15	85	205	60	25	2.9
SN 510-50	50	130	60	170	15	90	205	60	25	3.3
SN 511-55	55	135	70	210	18	95	255	70	28	4.6
SN 512-60	60	150	70	210	18	105	255	70	30	5.4
SN 513-65	65	155	80	230	18	110	275	80	30	6.7
SN 515-70	70	175	80	230	18	115	280	80	30	7.3
SN 516-75	75	185	95	260	22	120	315	90	32	9.3
SN 517-80	80	195	95	260	22	125	320	90	32	9.8
SN 518-90	90	215	100	290	22	145	345	100	35	12.5
SN 520-100	100	240	112	320	26	160	380	110	40	15.5
SN 522-110	110	270	125	350	26	175	410	120	45	19.8

Examples for arrangements and direction of rotation

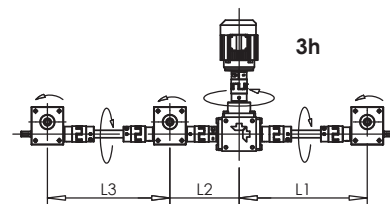
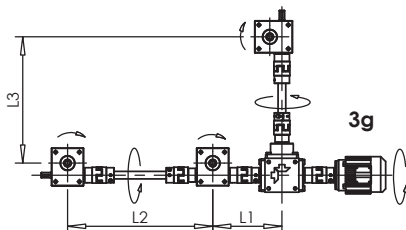
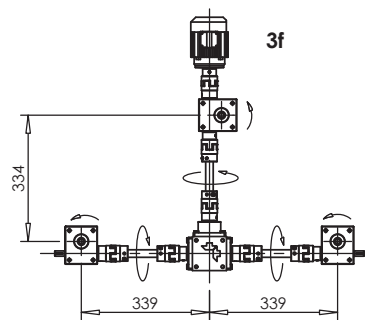
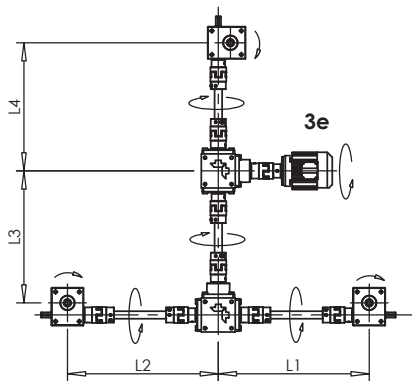
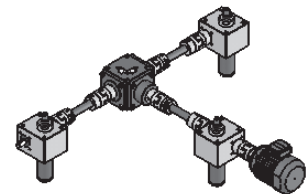
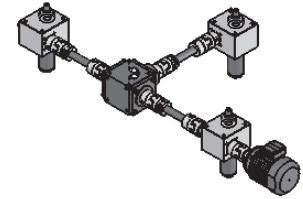
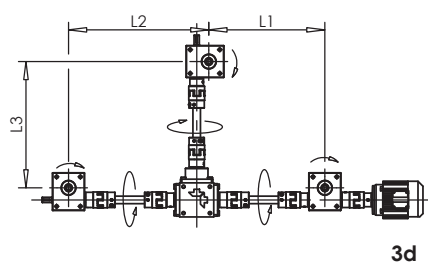
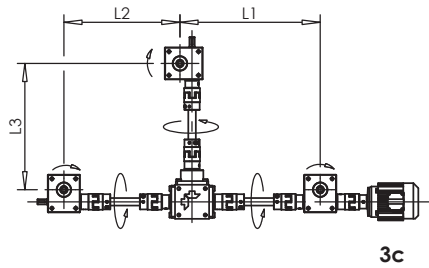
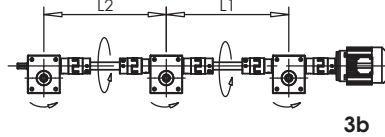
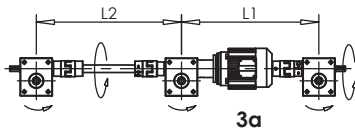
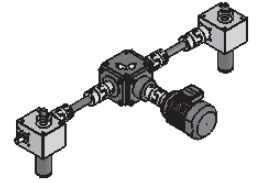
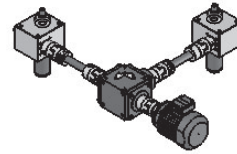
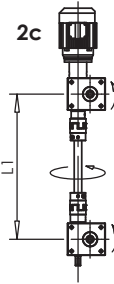
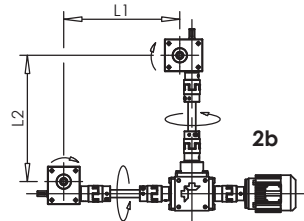
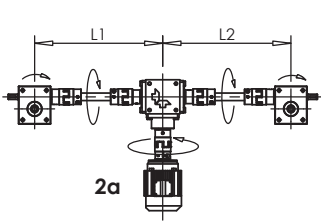
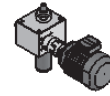
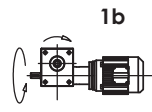
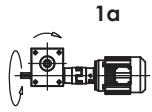

Examples for arrangements and direction of rotation

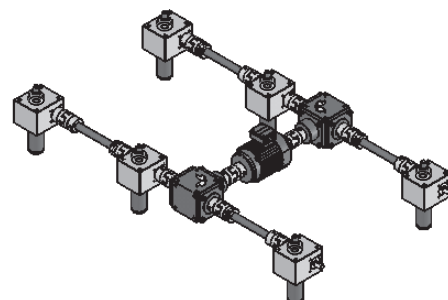
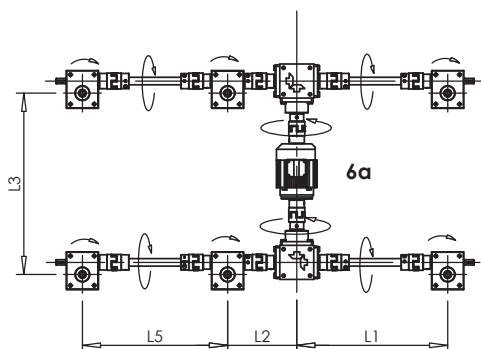
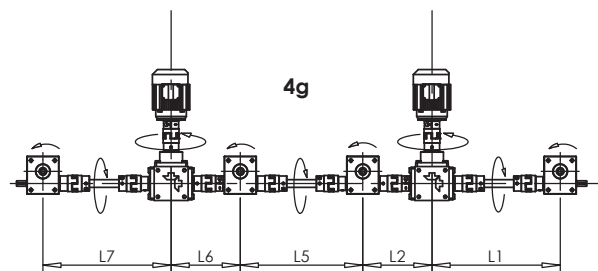
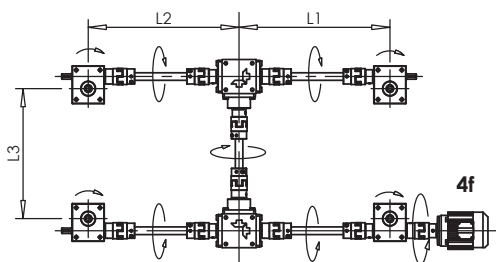
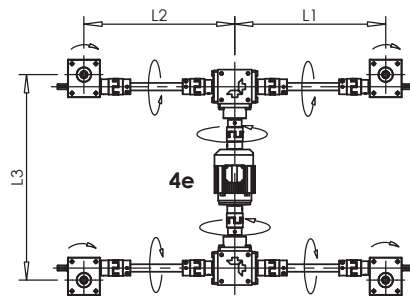
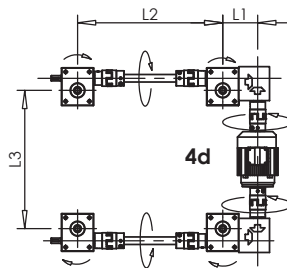
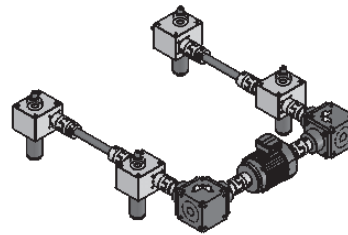
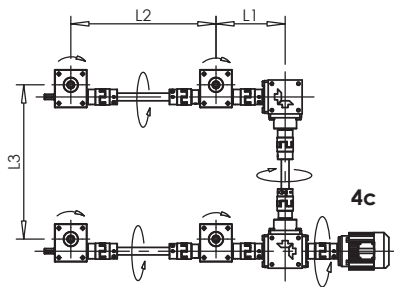
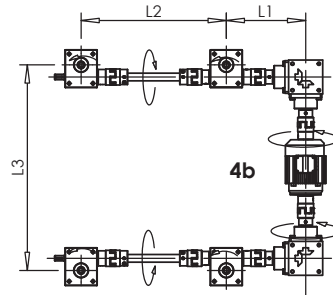
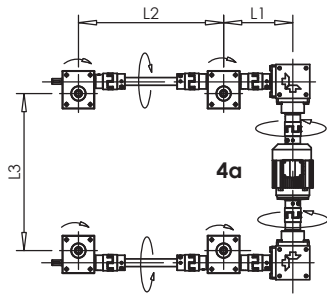

Selection of a worm gear screw jack and corresponding drive unit

After selecting the drive unit, it is important to check whether the worm gear screw jack or any transmission components may be overloaded by the drive unit.

The following points should also be established:

1. On which side is the motor to be mounted.
2. Direction of rotation of the jack systems.

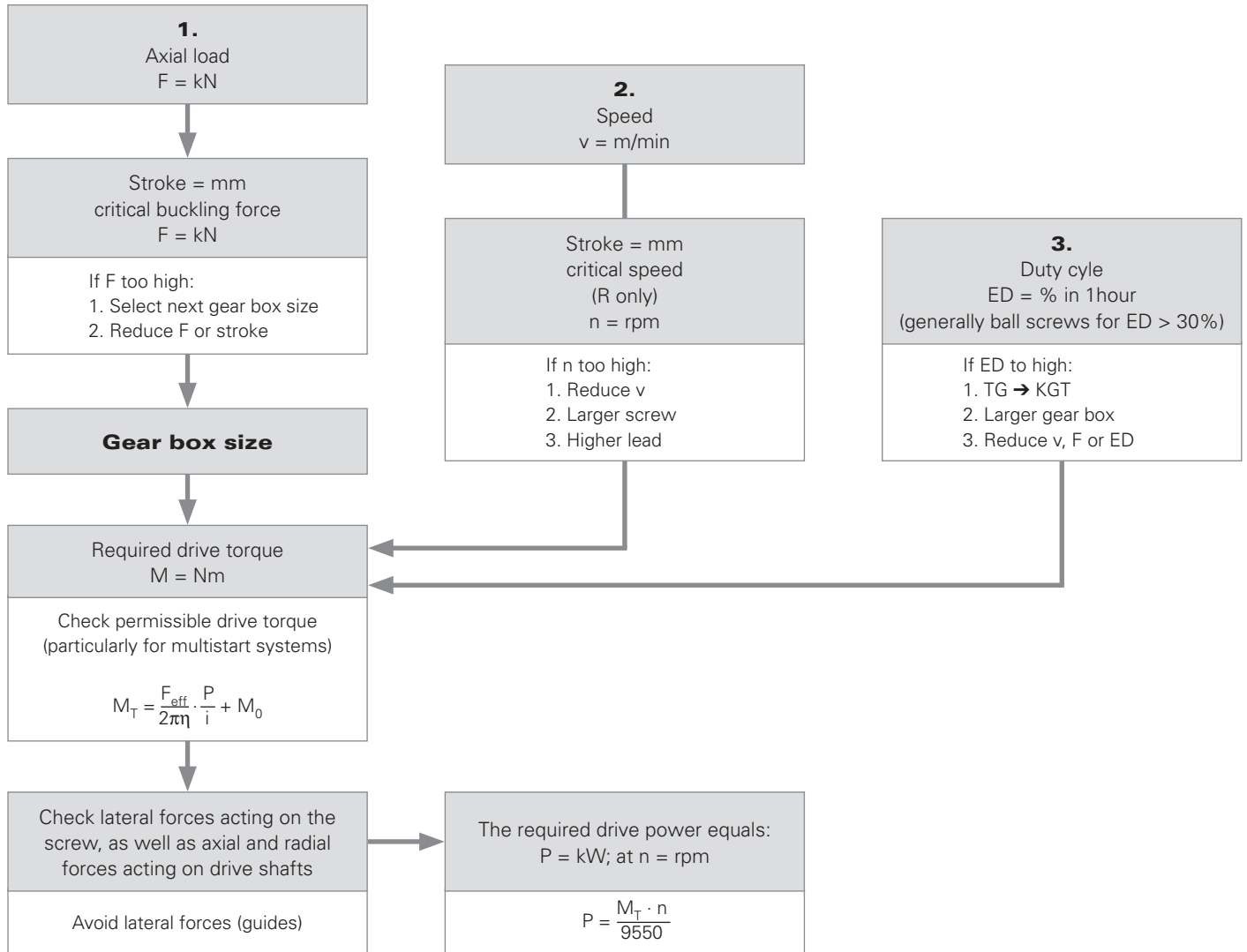

Forces and torque values acting on the worm gear screw jack

Note: Forces and torque values can only be estimated by making simplified assumptions. The coefficients of friction of sliding pairs, and thus the heat which these generate, and the resultant service lifetime depend on load, speed, temperature and lubrication conditions. Critical speeds and buckling lengths depend on the rigidity and mass of the clamping systems and machine frames, etc.

- F_{eff} = Axial force acting on the jack screw
- F_{S} = Result of all lateral forces acting on the jack screw
- M = Torque of the jack screw or nut (not applicable in the case of version V)
- V_{H} = Lifting speed
- F_{ax} = Axial force acting on drive shaft
- F_{r} = Radial force acting on drive shaft
- M_{T} = Drive torque
- n_{T} = Drive speed

Calculation

Load ratings of trapezoidal screw drives

As a general principle, the load rating of trapezoidal screw drives is dependent on their material, surface quality, state of wear, surface pressure, lubrication conditions, running speed and temperature, and thus on the duty cycle and the provision for the heat dissipation.

The permissible surface pressure is primarily dependent on the running speed of the screw drive.

With motion drives the surface pressure should not exceed 5 N per mm².

The permissible speed can be calculated from the supporting surface of the respective nut and the pv-factor of the respective nut materials.

pv-factors Material	pv-factors [N/mm ² · m/min]
G-CuSn 7 ZnPb (Rg 7)	300
G-CuSn 12 (G Bz 12)	400
Plastic (PETP)	100
Cast iron GG 22/GG 25	200

Required bearing surface

(VIII)

$$A_{\text{erf}} = \frac{F_{\text{ax}}}{P_{\text{zul}}}$$

Maximum linear running speed

(IX)

$$v_{\text{Gzul}} = \frac{\text{pv-factor}}{P_{\text{zul}}}$$

Maximum permissible speed of rotation

(X)

$$n_{\text{zul}} = \frac{v_{\text{Gzul}} \cdot 1000}{D \cdot \pi}$$

Permissible feed speed

(XI)

$$s_{\text{zul}} = \frac{n_{\text{zul}} \cdot P}{1000}$$

A_{erf} Required bearing surface [mm²]
 F_{ax} Total axial load [N]
 P_{zul} Maximum permissible surface pressure = 5 N/mm²

pv-factor See table
 v_{Gzul} Maximum linear running speed [m/min]

D Flank diameter [mm]
 n_{zul} Maximum permissible speed of rotation [rpm]

P Thread lead [mm]
 s_{zul} Permissible feed speed [m/min]

Example load rating calculation

Given: Screw drive,
 Trapezoidal screw with bronze nut $P_{\text{zul}} = 5 \text{ N/mm}^2$,
 Total axial load $F_{\text{ax}} = 10000 \text{ N}$

A_{erf} Required bearing surface [mm²]

from (VIII)

$$A_{\text{erf}} = \frac{F_{\text{ax}}}{P_{\text{zul}}} = \frac{10000 \text{ N}}{5 \text{ N/mm}^2} = 2000 \text{ mm}^2$$

Selection of bronze nut EFM of technical data

36 x 6 with bearing surface $A = 2140 \text{ mm}^2$

v_{Gzul} Maximum linear running speed [m/min]

from (IX)

$$v_{\text{Gzul}} = \frac{\text{pv-factor}}{P_{\text{zul}}} = \frac{300 \text{ N/mm}^2 \cdot \text{m/min}}{5 \text{ N/mm}^2} = 60 \text{ m/min}$$

n_{zul} Maximum permissible speed [rpm]

from (X)

$$n_{\text{zul}} = \frac{v_{\text{Gzul}} \cdot 1000}{D \cdot \pi} = \frac{60 \text{ m/min} \cdot 1000 \text{ mm/m}}{33 \text{ mm} \cdot \pi} = 579 \text{ rpm}$$

s_{zul} Permissible feed speed

from (XI)

$$s_{\text{zul}} = \frac{n_{\text{zul}} \cdot P}{1000} = \frac{579 \text{ rpm} \cdot 6 \text{ mm}}{1000 \text{ mm/m}} = 3.474 \text{ m/min}$$

Required: What travel speed is still permissible at this load?

P Thread lead = 6 mm
 D Flank diameter = $d - \frac{P}{2}$
 = $36 - \frac{6}{2}$ [mm]
 = 33 mm

With pv-factor for Rg 7 = 300 m/min

Result: At a load of 10.000 N, the trapezoidal screw drive can be operated at a speed of 3.474 metres per min.

Calculation

Critical speed of trapezoidal screws

With thin, fast-rotating screws, there is the danger of "whipping". The method described below allows the resonant frequency to be estimated assuming a sufficiently rigid assembly. Furthermore, speeds in the vicinity of the critical speed considerably increase the risk of lateral buckling. The critical speed is therefore included in the calculation of the critical buckling force.

Maximum permissible speed

$$(XII) \quad n_{zul} = 0.8 \cdot n_{kr} \cdot f_{kr}$$

n_{zul}	Maximum permissible speed [rpm]
n_{kr}	Theoretical critical speed [rpm], that can lead to resonance effects
f_{kr}	Correction factor considering the bearing support of the screw

Attention!

The operating speed must not exceed 80% of the maximum speed.

Bearing support

Typical values of correction factor f_{kr} corresponding to the usual cases of installation for standard screw bearings.

Critical buckling force of trapezoidal screws

With thin, fast-rotating screws under compressive load, there is the danger of lateral buckling.

The procedure described below can be used to calculate the permissible axial force according to Euler. Before the permissible compressive force is defined, allowance must be made for safety factors appropriate to the installation.

Maximum permissible axial force

$$(XIII) \quad F_{zul} = 0.8 \cdot F_k \cdot f_k$$

F_{zul}	Maximum permissible axial force [kN]
F_k	Theoretical critical buckling force [kN]
f_k	Correction factor considering the bearing support of the screw

Attention!

The operating force must not exceed 80% of the maximum permissible axial force.

Bearing support

Typical values of correction factor f_k corresponding to the usual cases of installation for standard screw bearings.

Calculation

Deflection of the screw under its own weight

Even in the case of correctly installed screw drives where the resulting radial forces are absorbed by external guides, the weight of the unsupported screw itself may lead to deflection. The formula below allows you to calculate the maximum deflection of the screw.

Maximum deflection of screw

$$(XIV) \quad f_{\max} = f_B \cdot 0.061 \cdot \frac{W_{TGS} \cdot L_{TGS}}{I_y}$$

f_B	Correction factor considering the bearing support of the screw
I_y	Planar moment of inertia [mm ⁴]
L_{TGS}	Unsupported screw length [mm]
W_{TGS}	Weight [kg/m]

Bearing support

Typical values of correction factor f_B corresponding to the usual cases of installation for standard screw bearings.

Example calculation for a trapezoidal screw drive

Given: Trapezoidal screw drive
 Screw RPTS Tr 24x5
 Length $L = 1500$ mm
 Installation case 2
 Maximum operating speed: $n_{\max} = 500$ [rpm]

Required: Is the operating speed uncritical?
 What is the permissible axial force?
 What is the maximum deflection?

Maximum permissible speed n_{zul}

from (XII)

$$n_{zul} = 0.8 \cdot n_{kr} \cdot f_{kr} = 0.8 \cdot 830 \text{ rpm} \cdot 1 = 664 \text{ rpm}$$

Theoretical critical speed $n_{kr} = 830$ rpm

from (XIII)

$$F_{zul} = 0.8 \cdot F_k \cdot f_k = 0.8 \cdot 4.2 \text{ kN} \cdot 1 = 3.36 \text{ kN}$$

Theoretical critical buckling force $F_k = 4.2$ kN

from (XIV)

$$f_{\max} = f_B \cdot 0.061 \cdot \frac{W_{TGS} \cdot L_{TGS}}{I_y} = 1 \cdot 0.061 \cdot \frac{2.85 \text{ kg/m} \cdot 1.5 \text{ m}}{0.460 \text{ cm}^4}$$

Weight $W_{TGS} = 2.85$ kg/m
 Planar moment of inertia $I_y = 0.460$ cm⁴

$$f_{\max} = 0.57 \text{ mm}$$

Result: The selected screw drive is uncritical at $n_{\max} = 500$ rpm.
 It can be loaded with a maximum axial force of 3.36 kN,
 and when installed horizontally has a maximum deflection
 of 0.57 mm.

(Note surface pressure and pv-factor!)

Calculation

Required drive torque and drive power

The required drive torque of a screw drive results from the axial load, the screw lead and the efficiency of the screw drive and bearings. With short run-up times and high speeds, the acceleration moment should be checked.

Note: In case of trapezoidal screw drives, in principle, there is always a breakaway moment to be overcome.

Required drive torque

(XV)

$$M_d = \frac{F_{ax} \cdot P}{2000 \cdot \pi \cdot \eta_A} = + M_{rot}$$

F_{ax}	Total axial load [N]
P	Thread lead [mm]
η_A	Efficiency of the overall drive $= \eta_{TGT} \cdot \eta_{fixed\ bearing} \cdot \eta_{movable\ bearing}$ $\eta_{TGT} (\mu = 0,1)$ $\eta_{fixed\ bearing} = 0.9 \dots 0.95$ $\eta_{movable\ bearing} = 0.95$
M_d	Required drive torque [Nm]
M_{rot}	Rotational acceleration torque [Nm] $= J_{rot} \cdot \alpha_0$ $= 7.7 \cdot d^4 \cdot L \cdot 10^{-13}$
J_{rot}	Rotational mass moment of inertia [kgm ²]
d	Nominal screw diameter [mm]
L	Screw length [mm]
α_0	Angular acceleration [1/s ²]

Efficiency η for coefficients of friction other than $\mu = 0,1$

(XVI)

$$\eta = \frac{\tan \alpha}{\tan (\alpha + \rho')}$$

η	Efficiency for converting a rotary motion into a linear motion
α	Helical angle of the thread [°]: $\tan \alpha = \frac{P}{d_2 \cdot \pi}$
	with P screw lead [mm] d_2 flank diameter [mm]
ρ'	Thread friction angle [°] $\tan \rho' = \mu \cdot 1.07$ for ISO-trapezoidal thread μ is the coefficient of friction

	μ during start-up (= μ_0)		μ in motion	
	dry	lubricated	dry	lubricated
Metal nuts	≈ 0.3	≈ 0.1	≈ 0.1	≈ 0.04
Plastic nuts	≈ 0.1	≈ 0.04	≈ 0.1	≈ 0.03

Required drive power

(XVII)

$$P_a = \frac{M_d \cdot n}{9550}$$

M_d	Required drive torque [Nm]
n	Screw speed [rpm]
P_a	Required drive power [kW]

Calculation

Required holding moment

(XVIII)

$$M_d' = \frac{F_{ax} \cdot P \cdot \eta'}{2000 \cdot \pi} + M_{rot}$$

Lifetime L

The (nominal) lifetime of a ball screw drive can be calculated analogue to that of a ball bearing.

Average speed

(I)

$$n_m = \frac{n_1 \cdot q_1 + n_2 \cdot q_2 + \dots + n_i \cdot q_i}{100}$$

Dynamic equivalent bearing load

(II)

$$F_m = \sqrt[3]{F_1^3 \cdot \frac{n_1 \cdot q_1}{n_m \cdot 100} + F_2^3 \cdot \frac{n_2 \cdot q_2}{n_m \cdot 100} + \dots + F_i^3 \cdot \frac{n_i \cdot q_i}{n_m \cdot 100}}$$

Lifetime of a ball screw

(III)

$$L_{10} = \left(\frac{C}{F_m} \right)^3 \cdot 10^6$$

Torque resulting from an axial load

Trapezoidal screw drives with a helical angle α greater than the friction angle ρ' , are not self-locking, i.e. the application of an axial load produces a screw torque. Efficiency η' for converting a linear motion into a rotary motion is lower than the conversion of a rotary motion into a linear motion.

F_{ax}	Total axial load [N]
P	Thread lead [mm]
η'	Efficiency for converting a linear motion into a rotary motion.
	$= \frac{\tan(\alpha - \rho')}{\tan \alpha}$
	$= 0.7 \cdot \eta$
	The effect of the efficiency of the bearing is negligible.
M_d'	Required holding moment [Nm]
M_{rot}	Rotational acceleration torque [Nm]
	$= J_{rot} \cdot \alpha_0$
	$= 7.7 \cdot d^4 \cdot L \cdot 10^{-13}$
J_{rot}	Rotational mass moment of inertia [kgm ²]
d	Nominal screw diameter [mm]
L	Screw length [mm]
α_0	Angular acceleration [1/s ²]

Attention!

Note that vibration and shocks reduce the lifetime of the ball screw drive.

n_1, n_2, \dots Speeds [rpm] during q_1, q_2, \dots

n_m Average speed [rpm]

q_1, q_2, \dots Components of the duration of a load in one load direction in [%]

F_1, F_2, \dots Axial loads [N] in one load direction during q_1, q_2, \dots

F_m Dynamic equivalent bearing load [N]
 Since loads can act on a ball screw drive in two directions, F_m should first be determined for each of two load directions; the larger value should then be included in the calculation of L . It is in general useful to draw a schematic diagram. It should be noted that any pre-loading represents a continuous load.

C Axial, dynamic load rating [N]
 Centrally applied load [N] of constant force direction at which an appropriately large number of identical ball screw drives achieve a nominal lifetime of 10^6 revolutions.

L_{10} Lifetime of the ball screw drive. Expressed as the number of revolutions achieved or exceeded by 90% (L_{10}) of a sufficiently large sample of obviously identical ball screw drives before the first signs of material fatigue occur.

Calculation

Example calculation lifetime of a ball screw drive

Given:

$F_1 = 30000 \text{ N}$ at $n_1 = 150 \text{ rpm}$ for $q_1 = 21 \%$ of the duration of operation
 $F_2 = 18000 \text{ N}$ at $n_2 = 1000 \text{ rpm}$ for $q_2 = 13 \%$ of the duration of operation
 $F_3 = 42000 \text{ N}$ at $n_3 = 75 \text{ rpm}$ for $q_3 = 52 \%$ of the duration of operation
 $F_4 = 1800 \text{ N}$ at $n_4 = 2500 \text{ rpm}$ for $q_4 = 14 \%$ of the duration of operation

$$\overline{\Sigma} = 100 \%$$

Required:

Maximum achievable lifetime under the given operating conditions.

Ball screw drive KGT 5010

Average speed n_m

from (I)

$$n_m = \frac{n_1 \cdot q_1 + n_2 \cdot q_2 + n_3 \cdot q_3 + n_4 \cdot q_4}{100}$$

$$n_m = \frac{150 \cdot 21 + 1000 \cdot 13 + 75 \cdot 52 + 2500 \cdot 14}{100} \text{ rpm}$$

$$\rightarrow n_m = 550,5 \text{ rpm}$$

Dynamic equivalent bearing load F_m

from (II)

$$F_m = \sqrt[3]{F_1^3 \cdot \frac{n_1 \cdot q_1}{n_m \cdot 100} + F_2^3 \cdot \frac{n_2 \cdot q_2}{n_m \cdot 100} + F_3^3 \cdot \frac{n_3 \cdot q_3}{n_m \cdot 100} + F_4^3 \cdot \frac{n_4 \cdot q_4}{n_m \cdot 100}}$$

$$F_m = \sqrt[3]{30000^3 \cdot \frac{150 \cdot 21}{550.5 \cdot 100} + 18000^3 \cdot \frac{1000 \cdot 13}{550.5 \cdot 100} + 42000^3 \cdot \frac{75 \cdot 52}{550.5 \cdot 100} + 1800^3 \cdot \frac{2500 \cdot 14}{550.5 \cdot 100}} \text{ N}$$

$$F_m = 18943 \text{ N}$$

Lifetime of a ball screw drive L_{10}

from (III)

$$L_{10} = \left(\frac{C}{F_m} \right)^3 \cdot 10^6$$

Axial, dynamic load rating $C = 68700 \text{ N}$

$$L_{10} = \left(\frac{68700}{18943} \right)^3 \cdot 10^6$$

Number of revolutions L_{10}

$$L_{10} = 47.7 \cdot 10^6$$

$$L_h = \frac{L_{10}}{n_m \cdot 60} = \frac{47.7 \cdot 10^6}{550.5 \cdot 60} = 1444 \text{ h}$$

Lifetime in hours L_h

Result: Under the given load conditions, the selected screw drive has a total lifetime of $47.7 \cdot 10^6$ revolutions, which represents a time of 1444 hours.

Calculation

Calculation of the dynamic equivalent bearing load F_m

Analog to the single nut

Lifetime L (IV)

$$L = \left(F_{m1}^{\frac{10}{3}} + F_{m2}^{\frac{10}{3}} \right)^{-0,9} \cdot C^3 \cdot 10^6$$

The calculation methods above are valid only under correct lubrication conditions. Dirt or lack of lubricant may significantly reduce the lifetime. Reduced lifetime must also be expected in the case of very short strokes – please contact us in these cases.

Attention!

Ball screw drives cannot absorb radial forces or tilting moments !

Maximum permissible speed

$$(V) \quad n_{zul} = 0,8 \cdot n_{kr} \cdot f_{kr}$$

Lifetime of a ball screw drive with pre-loaded nut system

The pre-loading force of the nut unit has the effect of a permanent load on the ball screw drive.

F_{m1}, F_{m2}, \dots Dynamic equivalent bearing load of the first or second nut [N].

C Axial, dynamic load rating [N]
Centrally applied load [N] of constant force direction at which an appropriately large number of identical ball screw drives achieve a nominal lifetime of 10^6 revolutions.

Critical speed of ball screws

With thin, fast-rotating screws, there is a danger of "whipping". The method described below allows the resonant frequency to be estimated assuming a sufficiently rigid assembly. Furthermore, speeds in the vicinity of the critical speed considerably increase the risk of lateral buckling. The critical speed is therefore included in the calculation of the critical buckling force.

n_{zul} Maximum permissible speed [rpm]
 n_{kr} Theoretical critical speed [rpm], that can lead to resonance effects
 f_{kr} Correction factor, considering the bearing support of the screw.

Attention!

The operating speed must not exceed 80 % of the maximum speed!

Bearing support

Typical values of correction factor f_{kr} corresponding to the usual cases of installation for standard screw bearings.

Calculation

Critical buckling force of ball screws

With thin, fast-rotating screws under compressive load, there is a danger of lateral buckling. The procedure described below can be used to calculate the permissible axial force according to Euler. Before the permissible compressive force is defined, allowance must be made for safety factors appropriate to the installation.

Maximum permissible axial force

$$(VI) \quad F_{zul} = 0.8 \cdot F_k \cdot f_k$$

F_{zul}	Maximum permissible axial force [kN]
F_k	Theoretical critical buckling force [kN]
f_k	Correction factor, considering the bearing support of the screw.

Attention!

The operating force must not exceed 80 % of the maximum permissible axial force.

Bearing support

Typical values of correction factor f_k corresponding to the usual cases of installation for standard screw bearings.

Deflection of the screw under its own weight

Even in the case of correctly installed screw drives where the resulting radial forces are absorbed by external guides, the weight of the un-supported screw itself may lead to deflection. The formula below allows you to calculate the maximum deflection of the screw.

Maximum deflection of screw

$$(VII) \quad f_{max} = f_B \cdot 0.061 \cdot \frac{w_{KGS} \cdot L_{KGS}^2}{I_Y}$$

f_B	Correction factor considering the bearing support of the screw [mm]
I_Y	Planar moment of inertia [mm ⁴]
L_{KGS}	Unsupported screw length [mm]
w_{KGS}	Weight [kg/m]

Bearing support

Typical values of correction factor f_B corresponding to the usual cases of installation for standard screw bearings.

Calculation

Example calculation for a ball screw drive

Given: Ball screw drive KGT 5010
Length $L = 2000$ mm
Installation case 3
Maximum operating speed: $n_{\max} = 3000$ [rpm]

Required: Is the operating speed uncritical?
What is the permissible axial force?
What is the maximum deflection?

Maximum permissible speed n_{zul}

from (V)

$$n_{\text{zul}} = 0.8 \cdot n_{\text{kr}} \cdot f_{\text{kr}} = 0.8 \cdot 1290 \text{ rpm} \cdot 1.47 = 1517 \text{ rpm}$$

→ $n_{\text{zul}} = 1517$ rpm (< limit speed!)

Theoretical critical speed $n_{\text{kr}} = 1290$ rpm

from (VI)

$$F_{\text{zul}} = 0.8 \cdot F_{\text{k}} \cdot f_{\text{k}} = 0.8 \cdot 95 \text{ kN} \cdot 2.05 = 156 \text{ kN}$$

→ $F_{\text{zul}} = 153$ kN (max. static load rating C_0 !)

Theoretical critical buckling force $F_{\text{k}} = 95$ kN

from (VII)

$$f_{\text{max}} = f_{\text{B}} \cdot 0.061 \cdot \frac{W_{\text{KGS}} \cdot L_{\text{KGS}}}{I_{\text{Y}}} = 0.41 \cdot 0.061 \cdot \frac{13.5 \text{ kg/m} \cdot 2 \text{ m}}{18.566 \text{ cm}^4}$$

Weight $W_{\text{KGS}} = 13.5$ kg/m

Planar moment of inertia $I_{\text{Y}} = 18.566$ cm⁴

$$f_{\text{max}} = 0.036 \text{ mm}$$

Result: The selected screw drive may be operated only at $n_{\max} = 1517$ rpm. It can be statically loaded with a maximum axial force of 150 kN, and when installed horizontally has a maximum deflection of 0.036 mm.

Note the dynamic load rating!

Drive sizing

Duty cycle and drive power

In order to limit the heat generated by friction within a worm gear screw jack, the lifting force and lifting speed are limited as a function of the relative duty cycle. The maximum permissible lifting force and lifting speed can be estimated with the aid of the following method.

$$F_{\text{eff}} \cdot V_H \leq F_{\text{stroke max}} \cdot V_{H \text{ max}} \cdot f_t$$

F_{eff} is the actual axial force acting on the jack screw [kN].

V_H is the lifting speed [mm/min].

$F_{\text{stroke max}}$ is the maximum permissible lifting force [kN]

$V_{H \text{ max}}$ is the maximum permissible lifting speed [mm/min]. It is calculated from the maximum permissible speed of the worm shaft of 1500 rpm (higher speeds on request) and the transmission ratio of the worm gear screw jack.

$V_{H \text{ max.}} = 1500$ mm/min for the version H gearing and 375 mm/min for the version L gearing. For the ball screw version, refer to the ratio of the worm gear screw jack in mm of stroke per full turn of the worm shaft.

f_t is a temperature factor which is dependent on the relative duty factor based on a period of 10 or 60 minutes at 20 °C.

The values determined here do not apply for very short reciprocating strokes. Please consult us in such cases.

f_t can be extrapolated to the left-hand edge of the graph in the case of very low relative duty cycles (less than 10 minutes, e.g. for occasional positioning operations, adjustments of levels, etc.). This yields the following approximate drive power values in kW with allowance for the efficiency in each case.

	M 0	M 1	M 2	M 3	M 4	M 5	J 1	J 2	J 3	J 4	J 5
Ratio H (trapezoidal)	0.18	0.3	0.55	1.18	2.3	4.7	6.5	8.4	10.9	14.7	19
Ratio L (trapezoidal)	0.12	0.19	0.35	0.75	1.4	3	4.2	5.4	7.3	9.3	12
Ball screws	0.18	0.3	0.56	0.95	1.7/3.2	5.9	–	–	13.9	–	–

These values are not a criterion for selecting the drive motor; it should be selected on the basis of torque, speed and operating conditions.

Drive sizing

Required drive torque

Required drive torque of a worm gear screw jack

The required drive torque of a worm gear screw jack is governed by the axial load acting on the jack screw, the transmission ratio and the efficiency. It should be noted that the breakaway torque may be considerably higher than the torque required for continuous running. This applies in particular to worm gear screw jacks with low efficiency after a long standstill period. The acceleration torque should be checked if necessary in cases with large screw pitches and very short run-up times.

$$M_T = \frac{F_{\text{eff}}}{2 \cdot \pi \cdot \eta} \cdot \frac{p}{i} + M_0$$

- M_T is the required drive torque of the worm gear screw drive at the worm shaft [Nm].
- F_{eff} is the actual force acting on the jack screw [kN].
- η is the efficiency of the worm gear screw jack in decimal notation, e.g. 0.32 instead of 32%. η is an average value determined by measurement.
- $\frac{p}{i}$ is the transmission ratio of the worm gear screw drive in mm stroke length per revolution of the worm shaft.
- M_0 is the idle torque of the worm gear screw drive [Nm]. M_0 is determined by measurements undertaken after a brief running-in period with liquid grease lubrication at room temperature. It represents an average value which may vary to a greater or lesser extent, depending on the running-in state, lubricant and temperature. For values, see table.

Required drive torque for a worm gear screw jack system

The required drive torque for a worm gear screw jack system is governed by the drive torque values for the individual jacks with allowance for the static and dynamic frictional losses in transmission components (coupling, universal joint shafts, pillow blocks, angle gear boxes, etc.). It is useful to draw a diagram illustrating the flow of forces.

$$M_{\text{drive motor}} = M_{T \text{ SHG1}} \cdot \frac{1}{\eta_{V1}} + M_{T \text{ SHG2}} + M_{T \text{ SHG3}} \cdot \frac{1}{\eta_{V2}} \cdot \frac{1}{\eta_K}$$

- $M_{T \text{ SHG1}}$ is the required drive torque for the worm gear screw jack SHG 1. It should be noted that the start-up torque (breakaway torque and possibly acceleration torque) may be considerably higher than the torque required for continuous running. This applies in particular to worm gear screw jacks with low efficiency after a long standstill period.
- η_{V1} (V1) includes the static and dynamic frictional losses in the pillow blocks and couplings.
- η_{V2} is the efficiency of connecting shaft V2.
 $\eta_V = 0.75 \dots 0.95$ depending on the length of the shaft and number of pillow blocks.
- η_K is the efficiency of the bevel gear box (only for the force flow via the toothing, i.e. between connecting shaft V2 and the drive motor).
 $\eta_K = 0.90$

Drive sizing

Required drive torque

Maximum drive torque

If the worm gear screw jack jams as a result of the screw coming into contact with an obstacle, the toothing can still absorb the following maximum torque values M_T at the drive shaft.

In the case of screw jacks connected in series, the screw jack closest to the drive can absorb this torque at its drive shaft.

Size	M_{Tmax} [Nm]
M 0	1.5
M 1	3.4
M 2	7.1
M 3	18
M 4	38
M 5	93
J 1	148
J 2	178
J 3	240
J 4	340
J 5	570

Acceleration values

Rotary current asynchronous motor, 4-pole:

- Approx. 0.5 m/s^2 (when switched on directly).

Servo motor:

- Max. 5 m/s^2 (limited by max. drive torque).

When using gear jacks in conjunction with servo motors, note that:

- Greater masses are moved, compared with linear axes.
- Predominantly, constant speeds with different revs are used.
- Use is often in the area of the adjustment/positioning of equipment.
- Positions with comparatively short power-on times are travelled to, and high acceleration values are therefore less frequently called for.
- High acceleration values have only a negligible effect on the overall stroke time, because of the low stroke speeds.

Forces and torque values acting on the drive shaft

If worm gear screw jacks are not driven free of lateral forces by means of a coupling connected to the motor shaft, but are instead driven by chains or belts, care must be taken to ensure that the radial force acting on the drive shaft does not exceed the limit values (see below).

In the worst case due to deflection through the radial force F_R the worm shaft will lift off of the worm wheel. This must be avoided, since it impairs the engagement between worm shaft and worm wheel and leads to higher wear.

Size	F_{Rmax} [kN]
M 0	0.07
M 1	0.1
M 2	0.2
M 3	0.3
M 4	0.5
M 5	0.8
J 1	0.8
J 2	1.3
J 3	1.3
J 4	2.1
J 5	3.1

Selection of drive motor

A suitable drive motor can be selected when the required drive torque and drive speed are known. After selecting a drive motor, check that it will not overload any of the worm gear screw jacks or transmission components. This risk may occur, in particular, in installations with several screw jacks if they are loaded unevenly. It will generally be necessary to install limit switches or torque-limiting couplings to protect the installation against impacting against end positions and obstacles.

Forces and torque values on the motor shaft

Toothed-belt or chain drives may exert considerable radial forces on the motor shaft if a very small sprocket is used. Please consult the motor manufacturer in cases of doubt.

Selection of a bevel gear box

Selection of a bevel gearbox is governed by the following factors:

- Drive torque
- Drive speed (see dimensional tables)
- Duty cycle and drive power
- Forces and torque values acting on the ends of the shaft (please consult us in cases of doubt)

Required drive speed

The required drive speed is governed by the desired lifting speed, the transmission ratio of the jack and the transmission ratio of the other transmission components. A particular lifting speed can normally be achieved in several ways. Correct selection depends on the following criteria:

- Favourable efficiency.
- Minimum load on transmission components in order to achieve compact, low-cost design.
- Avoiding critical speeds for jack screws and connecting shafts.

Jack screw nut torques

The nut torque (M) of the jack screw is the torque that the jack screw exerts on the mounting plate (all N versions except V), or the torque that the screw applies to the travelling nut (R Version). It is not to be confused with the drive torque (M_T) of the screw jack gears on the worm shaft.

$$M \text{ [Nm]} = F_{\text{eff}} \text{ [kN]} \cdot f_M \text{ (applicable in the areas of moderate and high loads)}$$

M is the jack screw nut torque [Nm] for the "Lift under Load" movement.

F_{eff} is the actual supported axial force [kN].

f_M is a conversion factor that accounts for screw geometry and friction. The value is applicable under normal lubrication conditions. The higher value needs to be used for dry friction and static friction. In the case of ball screw drives, f_M is practically constant.

Size	f_M (Trapezoidal screw)	f_M (Ball screw)
M 0	1.4	1.2
M 1	1.6	1.6
M 2	1.8	1.6
M 3	2.7	1.6
M 4	3.4	1.6/3.2
M 5	4.6	3.2
J 1	5.5	–
J 2	6.4	–
J 3	7.2	3.2
J 4	8.0	–
J 5	10.6	–

Drive sizing

Performance tables for worm gear screw jacks series M

Rotary speed, power requirement and permissible stroke speed for transmission ratio N and L with single-start, lifting (Ba1) trapezoidal screw. All performance data is related to the dynamic lifting force. The max. permissible drive powers can be increased in the case of duty cycle < 10 %/hour, or the version with a rotating spindle (Ba2).

M 0 screw Tr 14x4

n [rpm]	Lifting speed (m/min)		F = 2.5 [kN]				F = 2 [kN]				F = 1.5 [kN]				F = 1 [kN]				F = 0.75 [kN]				F = 0.5 [kN]				F = 0.25 [kN]				
			N		L		N		L		N		L		N		L		N		L		N		L		N		L		
			Nm	kW	Nm	kW	Nm	kW	Nm	kW	Nm	kW	Nm	kW	Nm	kW	Nm	kW	Nm	kW	Nm	kW	Nm	kW	Nm	kW	Nm	kW	Nm	kW	Nm
1500	1.50	0.375	1.2	0.18	0.4	0.1	0.9	0.15	0.3	0.1	0.7	0.1	0.2	0.1	0.5	0.1	0.2	0.1	0.4	0.1	0.1	0.1	0.2	0.1	0.1	0.1	0.1	0.1	0.1	0.0	0.1
1000	1.00	0.250	1.2	0.12	0.4	0.1	0.9	0.10	0.3	0.1	0.7	0.1	0.2	0.1	0.5	0.1	0.2	0.1	0.4	0.1	0.1	0.1	0.2	0.1	0.1	0.1	0.1	0.1	0.1	0.0	0.1
750	0.75	0.188	1.2	0.10	0.4	0.1	0.9	0.10	0.3	0.1	0.7	0.1	0.2	0.1	0.5	0.1	0.2	0.1	0.4	0.1	0.1	0.1	0.2	0.1	0.1	0.1	0.1	0.1	0.1	0.0	0.1
600	0.60	0.150	1.2	0.10	0.4	0.1	0.9	0.10	0.3	0.1	0.7	0.1	0.2	0.1	0.5	0.1	0.2	0.1	0.4	0.1	0.1	0.1	0.2	0.1	0.1	0.1	0.1	0.1	0.1	0.0	0.1
500	0.50	0.125	1.2	0.10	0.4	0.1	0.9	0.10	0.3	0.1	0.7	0.1	0.2	0.1	0.5	0.1	0.2	0.1	0.4	0.1	0.1	0.1	0.2	0.1	0.1	0.1	0.1	0.1	0.1	0.0	0.1
300	0.30	0.075	1.2	0.10	0.4	0.1	0.9	0.10	0.3	0.1	0.7	0.1	0.2	0.1	0.5	0.1	0.2	0.1	0.4	0.1	0.1	0.1	0.2	0.1	0.1	0.1	0.1	0.1	0.1	0.0	0.1
100	0.10	0.025	1.2	0.10	0.4	0.1	0.9	0.10	0.3	0.1	0.7	0.1	0.2	0.1	0.5	0.1	0.2	0.1	0.4	0.1	0.1	0.1	0.2	0.1	0.1	0.1	0.1	0.1	0.1	0.0	0.1
50	0.05	0.013	1.2	0.10	0.4	0.1	0.9	0.10	0.3	0.1	0.7	0.1	0.2	0.1	0.5	0.1	0.2	0.1	0.4	0.1	0.1	0.1	0.2	0.1	0.1	0.1	0.1	0.1	0.1	0.0	0.1

M 1 screw Tr 18x4

n [rpm]	Lifting speed (m/min)		F = 5 [kN]				F = 4 [kN]				F = 3 [kN]				F = 2.5 [kN]				F = 2 [kN]				F = 1.5 [kN]				F = 1 [kN]			
			N		L		N		L		N		L		N		L		N		L		N		L		N		L	
			Nm	kW	Nm	kW	Nm	kW	Nm	kW	Nm	kW	Nm	kW	Nm	kW	Nm	kW	Nm	kW	Nm	kW	Nm	kW	Nm	kW	Nm	kW	Nm	kW
1500	1.50	0.375	2.7	0.42	0.9	0.1	2.1	0.33	0.7	0.1	1.6	0.25	0.5	0.1	1.3	0.21	0.4	0.1	1.1	0.2	0.3	0.1	0.8	0.1	0.3	0.1	0.5	0.1	0.2	0.1
1000	1.00	0.250	2.7	0.28	0.9	0.1	2.1	0.22	0.7	0.1	1.6	0.17	0.5	0.1	1.3	0.14	0.4	0.1	1.1	0.1	0.3	0.1	0.8	0.1	0.3	0.1	0.5	0.1	0.2	0.1
750	0.75	0.188	2.7	0.21	0.9	0.1	2.1	0.17	0.7	0.1	1.6	0.13	0.5	0.1	1.3	0.10	0.4	0.1	1.1	0.1	0.3	0.1	0.8	0.1	0.3	0.1	0.5	0.1	0.2	0.1
600	0.60	0.150	2.7	0.17	0.9	0.1	2.1	0.13	0.7	0.1	1.6	0.10	0.5	0.1	1.3	0.10	0.4	0.1	1.1	0.1	0.3	0.1	0.8	0.1	0.3	0.1	0.5	0.1	0.2	0.1
500	0.50	0.125	2.7	0.14	0.9	0.1	2.1	0.10	0.7	0.1	1.6	0.10	0.5	0.1	1.3	0.10	0.4	0.1	1.1	0.1	0.3	0.1	0.8	0.1	0.3	0.1	0.5	0.1	0.2	0.1
300	0.30	0.075	2.7	0.10	0.9	0.1	2.1	0.10	0.7	0.1	1.6	0.10	0.5	0.1	1.3	0.10	0.4	0.1	1.1	0.1	0.3	0.1	0.8	0.1	0.3	0.1	0.5	0.1	0.2	0.1
100	0.10	0.025	2.7	0.10	0.9	0.1	2.1	0.10	0.7	0.1	1.6	0.10	0.5	0.1	1.3	0.10	0.4	0.1	1.1	0.1	0.3	0.1	0.8	0.1	0.3	0.1	0.5	0.1	0.2	0.1
50	0.05	0.013	2.7	0.10	0.9	0.1	2.1	0.10	0.7	0.1	1.6	0.10	0.5	0.1	1.3	0.10	0.4	0.1	1.1	0.1	0.3	0.1	0.8	0.1	0.3	0.1	0.5	0.1	0.2	0.1

M 2 screw Tr 20x4

n [rpm]	Lifting speed (m/min)		F = 10 [kN]				F = 8 [kN]				F = 6 [kN]				F = 4 [kN]				F = 3 [kN]				F = 2 [kN]				F = 1 [kN]			
			N		L		N		L		N		L		N		L		N		L		N		L		N		L	
			Nm	kW	Nm	kW	Nm	kW	Nm	kW	Nm	kW	Nm	kW	Nm	kW	Nm	kW	Nm	kW	Nm	kW	Nm	kW	Nm	kW	Nm	kW	Nm	kW
1500	1.50	0.375	5.7	0.89	1.9	0.30	4.5	0.71	1.5	0.24	3.4	0.54	1.1	0.18	2.3	0.36	0.8	0.1	1.7	0.27	0.6	0.1	1.1	0.2	0.4	0.1	0.6	0.1	0.2	0.1
1000	1.00	0.250	5.7	0.60	1.9	0.20	4.5	0.48	1.5	0.16	3.4	0.36	1.1	0.12	2.3	0.24	0.8	0.1	1.7	0.18	0.6	0.1	1.1	0.1	0.4	0.1	0.6	0.1	0.2	0.1
750	0.75	0.188	5.7	0.45	1.9	0.15	4.5	0.36	1.5	0.12	3.4	0.27	1.1	0.10	2.3	0.18	0.8	0.1	1.7	0.13	0.6	0.1	1.1	0.1	0.4	0.1	0.6	0.1	0.2	0.1
600	0.60	0.150	5.7	0.36	1.9	0.12	4.5	0.29	1.5	0.10	3.4	0.21	1.1	0.10	2.3	0.14	0.8	0.1	1.7	0.10	0.6	0.1	1.1	0.1	0.4	0.1	0.6	0.1	0.2	0.1
500	0.50	0.125	5.7	0.30	1.9	0.10	4.5	0.24	1.5	0.10	3.4	0.18	1.1	0.10	2.3	0.12	0.8	0.1	1.7	0.10	0.6	0.1	1.1	0.1	0.4	0.1	0.6	0.1	0.2	0.1
300	0.30	0.075	5.7	0.18	1.9	0.10	4.5	0.14	1.5	0.10	3.4	0.11	1.1	0.10	2.3	0.10	0.8	0.1	1.7	0.10	0.6	0.1	1.1	0.1	0.4	0.1	0.6	0.1	0.2	0.1
100	0.10	0.025	5.7	0.10	1.9	0.10	4.5	0.10	1.5	0.10	3.4	0.10	1.1	0.10	2.3	0.10	0.8	0.1	1.7	0.10	0.6	0.1	1.1	0.1	0.4	0.1	0.6	0.1	0.2	0.1
50	0.05	0.013	5.7	0.10	1.9	0.10	4.5	0.10	1.5	0.10	3.4	0.10	1.1	0.10	2.3	0.10	0.8	0.1	1.7	0.10	0.6	0.1	1.1	0.1	0.4	0.1	0.6	0.1	0.2	0.1

Drive sizing

Performance tables for worm gear screw jacks series M

M 3 screw Tr 30x6

n [rpm]	Lifting speed (m/min)		F = 25 [kN]				F = 20 [kN]				F = 15 [kN]				F = 10 [kN]				F = 5 [kN]				F = 2.5 [kN]				F = 1 [kN]			
			N		L		N		L		N		L		N		L		N		L		N		L		N		L	
			Nm	kW	Nm	kW	Nm	kW	Nm	kW	Nm	kW	Nm	kW	Nm	kW	Nm	kW	Nm	kW	Nm	kW	Nm	kW	Nm	kW	Nm	kW	Nm	kW
1500	1.50	0.375	14.7	2.31	5.2	0.82	11.8	1.85	4.2	0.66	8.8	1.39	3.1	0.49	5.9	0.93	2.1	0.33	2.9	0.46	1.0	0.2	1.5	0.2	0.5	0.1	0.6	0.1	0.2	0.1
1000	1.00	0.250	14.7	1.54	5.2	0.55	11.8	1.23	4.2	0.44	8.8	0.93	3.1	0.33	5.9	0.62	2.1	0.22	2.9	0.31	1.0	0.1	1.5	0.2	0.5	0.1	0.6	0.1	0.2	0.1
750	0.75	0.188	14.7	1.16	5.2	0.41	11.8	0.93	4.2	0.33	8.8	0.69	3.1	0.25	5.9	0.46	2.1	0.16	2.9	0.23	1.0	0.1	1.5	0.1	0.5	0.1	0.6	0.1	0.2	0.1
600	0.60	0.150	14.7	0.93	5.2	0.33	11.8	0.74	4.2	0.26	8.8	0.56	3.1	0.20	5.9	0.37	2.1	0.13	2.9	0.19	1.0	0.1	1.5	0.1	0.5	0.1	0.6	0.1	0.2	0.1
500	0.50	0.125	14.7	0.77	5.2	0.27	11.8	0.62	4.2	0.22	8.8	0.46	3.1	0.16	5.9	0.31	2.1	0.11	2.9	0.15	1.0	0.1	1.5	0.1	0.5	0.1	0.6	0.1	0.2	0.1
300	0.30	0.075	14.7	0.46	5.2	0.16	11.8	0.37	4.2	0.13	8.8	0.28	3.1	0.10	5.9	0.19	2.1	0.10	2.9	0.10	1.0	0.1	1.5	0.1	0.5	0.1	0.6	0.1	0.2	0.1
100	0.10	0.025	14.7	0.15	5.2	0.10	11.8	0.12	4.2	0.10	8.8	0.10	3.1	0.10	5.9	0.10	2.1	0.10	2.9	0.10	1.0	0.1	1.5	0.1	0.5	0.1	0.6	0.1	0.2	0.1
50	0.05	0.013	14.7	0.10	5.2	0.10	11.8	0.10	4.2	0.10	8.8	0.10	3.1	0.10	5.9	0.10	2.1	0.10	2.9	0.10	1.0	0.1	1.5	0.1	0.5	0.1	0.6	0.1	0.2	0.1

M 4 screw Tr 40x7

n [rpm]	Lifting speed (m/min)		F = 50 [kN]				F = 40 [kN]				F = 30 [kN]				F = 20 [kN]				F = 10 [kN]				F = 5 [kN]				F = 2.5 [kN]			
			N		L		N		L		N		L		N		L		N		L		N		L		N		L	
			Nm	kW	Nm	kW	Nm	kW	Nm	kW	Nm	kW	Nm	kW	Nm	kW	Nm	kW	Nm	kW	Nm	kW	Nm	kW	Nm	kW	Nm	kW	Nm	kW
1500	1.50	0.375	31.8	5.0	11.1	1.7	25.5	4.0	8.8	1.4	19.1	3.0	6.6	1.0	12.7	2.0	4.4	0.70	6.4	1.0	2.2	0.3	3.2	0.5	1.1	0.1	1.6	0.3	0.6	0.1
1000	1.00	0.250	31.8	3.3	11.1	1.2	25.5	2.7	8.8	0.9	19.1	2.0	6.6	0.7	12.7	1.3	4.4	0.50	6.4	0.7	2.2	0.2	3.2	0.3	1.1	0.1	1.6	0.2	0.6	0.1
750	0.75	0.188	31.8	2.5	11.1	0.9	25.5	2.0	8.8	0.7	19.1	1.5	6.6	0.5	12.7	1.0	4.4	0.35	6.4	0.5	2.2	0.2	3.2	0.3	1.1	0.1	1.6	0.1	0.6	0.1
600	0.60	0.150	31.8	2.0	11.1	0.7	25.5	1.6	8.8	0.6	19.1	1.2	6.6	0.4	12.7	0.8	4.4	0.30	6.4	0.4	2.2	0.1	3.2	0.2	1.1	0.1	1.6	0.1	0.6	0.1
500	0.50	0.125	31.8	1.7	11.1	0.6	25.5	1.3	8.8	0.5	19.1	1.0	6.6	0.3	12.7	0.7	4.4	0.20	6.4	0.3	2.2	0.1	3.2	0.2	1.1	0.1	1.6	0.1	0.6	0.1
300	0.30	0.075	31.8	1.0	11.1	0.3	25.5	0.8	8.8	0.3	19.1	0.6	6.6	0.2	12.7	0.4	4.4	0.10	6.4	0.2	2.2	0.1	3.2	0.1	1.1	0.1	1.6	0.1	0.6	0.1
100	0.10	0.025	31.8	0.3	11.1	0.1	25.5	0.3	8.8	0.1	19.1	0.2	6.6	0.1	12.7	0.1	4.4	0.10	6.4	0.1	2.2	0.1	3.2	0.1	1.1	0.1	1.6	0.1	0.6	0.1
50	0.05	0.013	31.8	0.2	11.1	0.1	25.5	0.1	8.8	0.1	19.1	0.1	6.6	0.1	12.7	0.1	4.4	0.10	6.4	0.1	2.2	0.1	3.2	0.1	1.1	0.1	1.6	0.1	0.6	0.1

M 5 screw Tr 60x9

n [rpm]	Lifting speed (m/min)		F = 150 [kN]				F = 100 [kN]				F = 80 [kN]				F = 60 [kN]				F = 40 [kN]				F = 20 [kN]				F = 10 [kN]			
			N		L		N		L		N		L		N		L		N		L		N		L		N		L	
			Nm	kW	Nm	kW	Nm	kW	Nm	kW	Nm	kW	Nm	kW	Nm	kW	Nm	kW	Nm	kW	Nm	kW	Nm	kW	Nm	kW	Nm	kW	Nm	kW
1500	1.50	0.375	125.7	19.7	42.6	6.7	83.8	13.2	28.4	4.5	67.0	10.5	22.7	3.6	50.3	7.9	17.1	2.7	33.5	5.3	11.4	1.8	16.8	2.6	5.7	0.9	8.4	1.3	2.8	0.4
1000	1.00	0.250	125.7	13.2	42.6	4.5	83.8	8.8	28.4	3.0	67.0	7.0	22.7	2.4	50.3	5.3	17.1	1.8	33.5	3.5	11.4	1.2	16.8	1.8	5.7	0.6	8.4	0.9	2.8	0.3
750	0.75	0.188	125.7	9.9	42.6	3.3	83.8	6.6	28.4	2.2	67.0	5.3	22.7	1.8	50.3	3.9	17.1	1.3	33.5	2.6	11.4	0.9	16.8	1.3	5.7	0.4	8.4	0.7	2.8	0.2
600	0.60	0.150	125.7	7.9	42.6	2.7	83.8	5.3	28.4	1.8	67.0	4.2	22.7	1.4	50.3	3.2	17.1	1.1	33.5	2.1	11.4	0.7	16.8	1.1	5.7	0.4	8.4	0.5	2.8	0.2
500	0.50	0.125	125.7	6.6	42.6	2.2	83.8	4.4	28.4	1.5	67.0	3.5	22.7	1.2	50.3	2.6	17.1	0.9	33.5	1.8	11.4	0.6	16.8	0.9	5.7	0.3	8.4	0.4	2.8	0.1
300	0.30	0.075	125.7	3.9	42.6	1.3	83.8	2.6	28.4	0.9	67.0	2.1	22.7	0.7	50.3	1.6	17.1	0.5	33.5	1.1	11.4	0.4	16.8	0.5	5.7	0.2	8.4	0.3	2.8	0.1
100	0.10	0.025	125.7	1.3	42.6	0.4	83.8	0.9	28.4	0.3	67.0	0.7	22.7	0.2	50.3	0.5	17.1	0.2	33.5	0.4	11.4	0.1	16.8	0.2	5.7	0.1	8.4	0.1	2.8	0.1
50	0.05	0.013	125.7	0.7	42.6	0.2	83.8	0.4	28.4	0.1	67.0	0.4	22.7	0.1	50.3	0.3	17.1	0.1	33.5	0.2	11.4	0.1	16.8	0.1	5.7	0.1	8.4	0.1	2.8	0.1

Installation and maintenance

Trapezoidal screw drives TGT Installation

Trapezoidal screw drives must be aligned carefully during installation – if suitable measuring equipment is not available, the screw drive should be turned through its entire length by hand before the drive unit is attached. Variations in the amount of force required and/or marks on the external diameter of the screw indicate alignment errors between the screw axis and guide. In this case, the relevant mounting bolts should first be loosened and the screw drive should be turned through by hand. If the amount of force required is now constant throughout, the appropriate components should be aligned, otherwise the alignment error should be localised by loosening further mounting bolts.

Cover

By virtue of their design, trapezoidal screw drives are less sensitive to dirt than ball screw drives, particularly at low speeds (manual operation).

Never the less motion drives, especially with plastic nuts, in particular require protection against dirt in the same way as ball screw drives.

Lubrication

Oil lubrication

Used only in special cases for trapezoidal screw drives..

Grease lubrication

The usual lubrication method for trapezoidal screw drives. Lubrication intervals are governed by operating conditions; it is advisable to clean the screw before greasing especially at use of heavy-duty lubricating machines.

Type of grease: ball bearing grease without solid lubricant parts ref. NELL GO.

Operating temperature

This depends on the type of nut used, the lubrication conditions and the user's requirements. Please consult us in the case of temperatures above 100 °C (plastic nuts 70 °C).

Wear

This can be checked manually: if the axial backlash with a single-start screw drive is more than $\frac{1}{4}$ of the lead, the nut should be replaced.

Ball screw drives KGT Installation

Ball screw drives are precision machine components; their installation requires specialist knowledge and suitable measuring facilities. Alignment errors can generally not be felt when the screw drive is turned by hand, due to the low friction. Radial or eccentric forces must be taken up by external guides. Ball screw drives can absorb only axial forces. To avoid damage to the ball screw drive, limit switches and end stops must be installed in the machine.

Cover

Dirt that occurs during installation should be removed with paraffin, oil or petrol. Cold cleaners and paint solvents are not permitted. Ball screw drives must be protected against dust, chips, etc. even if equipped with wipers. Possible protective measures include:

- Bellows (suitable only for vertical installation without additional guide).
- Spiral spring cover.
- Telescopic tubes or sleeves (these take up a lot of axial space).

Lubrication

Proper lubrication is important for the achievement of the calculated service lifetime of a ball screw drive, to prevent excessive warming, and to ensure smooth, quiet running. The same lubricants are used for the ball screw drives as for roller bearings.

Oil-mist lubrication

In the case of central lubrication with oil mist, note that only ball screw nuts without wipers may be used.

Oil lubrication

The oil supply should not exceed the volume lost via the wipers; otherwise use recirculating-oil lubrication.

Oil types: Viscosity 25 to 100 mm²/s at 100 °C.

Grease lubrication

Add grease as appropriate to the volume lost via the wipers (under normal operating conditions, it is sufficient to add grease every 200 to 300 hours). Experience shows that one-time lubrication for the service lifetime is not sufficient because of the seepage of grease.

Grease type:

Roller bearing grease with no solid lubricant content. The first fill takes place at the supplier's with roller bearing grease. We recommend Neff Gear-1 grease in the case of high mechanical stresses.

Operating temperature

The permissible operating temperature range for ball screw drives is between –30 °C and +80 °C, up to +110 °C for brief periods. A precondition for this is correct lubrication. The torque may increase by a factor of up to 10 at temperatures below –20 °C.

Installation and maintenance

Installation of worm gear screw jack systems

Direction of rotation

Before starting installation work, the direction of rotation of all worm gear screw jacks, bevel gear boxes and the drive motor must be checked with regard to the feed direction of each individual worm gear screw jack.

Alignment errors

All components must be carefully aligned during installation. Alignment errors and stresses increase power consumption and lead to overheating and premature wear. Before a drive unit is attached, each worm gear screw jack should be turned through its entire length by hand without load. Variations in the amount of force required and/or axial marks on the outside diameter of the screw indicate alignment errors between the worm gear screw jack and its additional guides. In this case, the relevant mounting bolts must be loosened and the worm gear screw jack turned through by hand again. If the amount of force required is now constant throughout, the appropriate components must be aligned. If not, the alignment error must be localized by loosening additional mounting bolts.

Test run

The direction of rotation of the complete system and correct operation of the limit switches must be checked again before attaching the drive motor. In the case of version N (translating screw jack), check that the screw is lubricated with grease from the interior of the gear box and relubricate if necessary. In the case of version R (rotating screw jack), the jack screw should be coated with suitable grease to provide lubrication for lifting operation. The first test runs can then be carried out without load.

A maximum operating time of 30 % can not be exceeded at trial runs under weight for worm gear screw jacks with trapezoidal screws.

Operation

The loads, speeds and operating conditions specified for the worm gear screw jacks and transmission components must not be exceeded even briefly. Failure to observe this condition will invalidate all claims under guarantee.

Torque guidelines for mounting of bearing covers

Type	Fastening Torque [Nm]
M 0	3
M 1	5
M 2	9
M 3	13
M 4	32
M 5	60
J 1	70
J 2	150
J 3	150
J 4	220
J 5	300

Maintenance of worm gear screw jacks

Safety

All mounting bolts must be retightened after a short period of operation. Under extreme operating conditions, the wear on the screw nut (worm gear) must be checked at shorter intervals, depending on the power-on time, by inspecting the play in the thread. The screw nut (worm gear) must be replaced if the axial backlash with a single-start thread is more than one-quarter of the thread pitch.

Lubrication

The worm gear screw jacks are lubricated by the manufacturer and are ready for operation on delivery.

The versions N/V must be lubricated via their grease nipples with one of the greases specified below at intervals of 50 – 100 operating hours. The screw should be cleaned and greased at the same time. We recommend that the gear box be cleaned to remove old grease and refilled with fresh grease after approx. 1500 operating hours or 36 months. The worm gear screw jacks can be dismantled relatively easily:

- Unscrew the two threaded pins securing the bearing cover.
- Unscrew the screw and remove the screw protection if necessary.
- Unscrew the bearing cover with the aid of a face spanner.

Proceed as follows to refit the bearing cover: fit the bearing cover firmly (using approx. ten times the force shown in the table of "Guideline values for fitting bearing cover"). Then release it and refit it with the guide-line value from the table, checking the axial backlash and smooth running.

Standard grease:
Neffgear MP 1/2

Recommended greases:
Castrol Spheerol BM2
Mobil Mobilgrease XHP
Shell Retinax HD2
Klüber Microlube GBO

Lubrication per screw jack

Type	kg
M 0	0.03
M 1	0.06
M 2	0.14
M 3	0.24
M 4	0.8
M 5	1.1
J 1	1.5
J 2	2.0
J 3	2.0
J 4	2.7
J 5	3.2

This catalogue was prepared with great care and all details have been checked for accuracy. No liability can be accepted for any errors or omissions.

For the commercial supply of goods or services the conditions of sale and supply as quoted in the relevant acknowledgement of order will be valid.

We reserve the right to change or modify our products due to constant further developments.

All rights reserved, reproduction of the contents, whole or in part, is not allowed without our consent.



Contact

NEFF Gewindetriebe GmbH
Karl-Benz-Str. 24
71093 Weil im Schönbuch
Post box 1230
71108 Waldenbuch

Phone: +49 (0) 71 57/5 38 90-0
Fax: +49 (0) 71 57/5 38 90-25
www.neff-gewindetriebe.de
info@neff-gewindetriebe.de