

# Beyond Bits

## Health and Safety

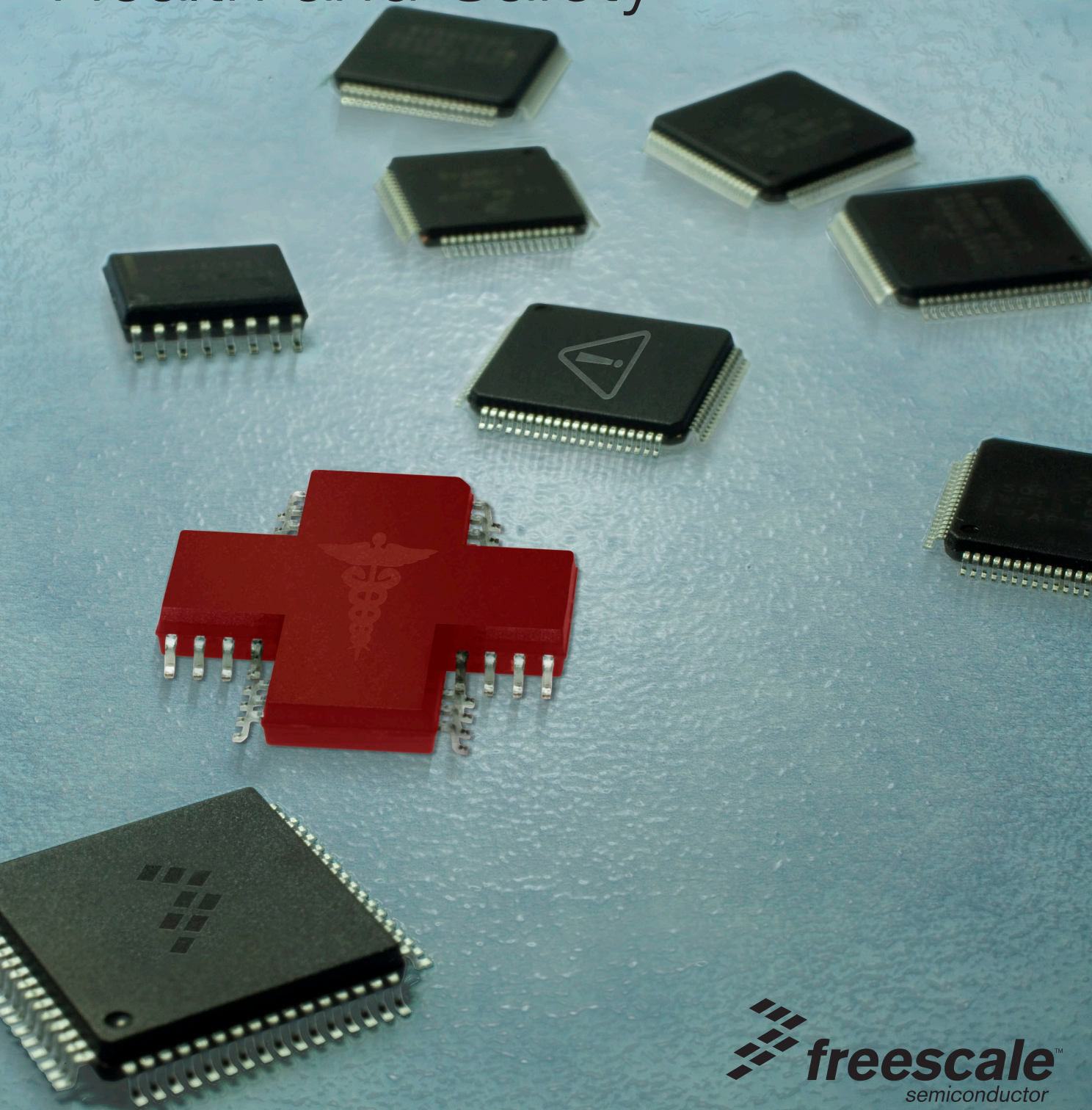

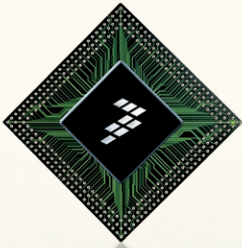

# It's making the world a smarter place.

## Freescal e Technology Forum

**Collaboration. Innovation. Inspiration.**

Freescal e Technology Forum (FTF) events around the globe bring the entire Freescal e ecosystem together to create a unique, energizing and inspiring environment of innovation and collaboration.

### FTF 2009 Global Program

|             |                     |  |
|-------------|---------------------|--|
| Virtual FTF | July 14–16, 2009    | <a href="http://www.freescal e.com/FTF">www.freescal e.com/FTF</a> |
| FTF China   | August 27–28, 2009  | Shenzhen   |
| FTF India   | September 2–3, 2009 | Bangalore  |
| FTF Japan   | September 9, 2009   | Tokyo  |

For detailed information about each of these exciting events, visit [www.freescal e.com/FTF](http://www.freescal e.com/FTF)





Issue 4

# Beyond Bits

## Health and Safety

Welcome to the fourth edition of *Beyond Bits*. This edition focuses on health and safety.

Our world is changing—the median age of the world’s population is increasing and we are living longer. As individuals and global citizens, solutions that help us lead safer and healthier lives are top of mind. And as engineers, we believe we can design smarter, more efficient embedded applications that will contribute to the well-being of people around the world. To help you create this next generation of products, we filled this publication with state-of-the-art platform solutions and expert advice from our engineers. Freescale products—from sensors to microcontrollers to wireless connectivity technology—are featured in this *Beyond Bits* to help you build advanced applications designed to promote health and safety.

Health care providers are increasingly relying on portable medical technology and tools to assist in advancing, maintaining and restoring health. For instance, in the article *ZigBee® Technology for Long-Term Care*, we demonstrate how combining Freescale microcontroller, sensor and ZigBee wireless technologies can help maximize the independence of long-term care patients and minimize the effects of disability and illness. Or, read the article *Wireless Sound Notification System* and learn how an IEEE® 802.15.4 wireless-based platform using Freescale components can help visually impaired persons move about safely.

These are just two examples of the twenty articles in *Beyond Bits IV* that will spur your imagination and inspire innovative design that is essential to making *good lives* better.

We hope you enjoy this edition.

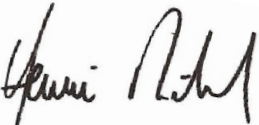

Henri Richard  
Senior Vice President, Chief Sales and Marketing Officer

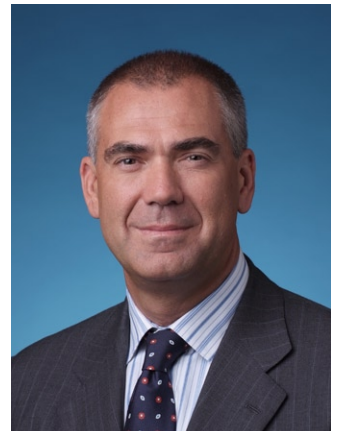

### We want to hear from you!

Send your design ideas, tips or questions to [freescale.com/beyondbits](http://freescale.com/beyondbits).

# Beyond Bits

## Table of Contents

---

|   |           |
|---|-----------|
| <b>Blood Pressure Monitors</b><br>Inga Harris   | <b>4</b>  |
| <b>ZigBee® Technology for Long-Term Care</b><br>Matt Maupin and Sampath Raghavan                                | <b>10</b> |
| <b>Gestational Diabetes</b><br>Donnie Garcia and Alejandra Guzman Castellanos with Dr. Claudia Rentería Govillo | <b>16</b> |
| <b>Sports Game Station</b><br>Shen Li and Ju Yingyi with Dr. Gabriela López and Dr. Sergio Rosales              | <b>21</b> |
| <b>Telemonitoring Solutions</b><br>Dr. Jose Fernandez Villaseñor and Jesus Gaytan                               | <b>24</b> |
| <b>Low-Energy Wireless: Just What the Doctor Ordered</b><br>Raman Sharma  | <b>29</b> |
| <b>Automatic Ventilation Control</b><br>Alfredo Soto with Dr. Juan Carrillo Jiménez                             | <b>32</b> |
| <b>Health Social Networks</b><br>Kurt Seifert   | <b>35</b> |
| <b>Human Factors and the Control of Medical Device-Related Error</b><br>Larry Fenningkoh and Diego Haro         | <b>39</b> |
| <b>Beyond Accidental Falls</b><br>Rogelio Reyna and Kim Tuck with Dr. Daniel Copado                             | <b>44</b> |
| <b>Changing the High-Complexity Paradigm</b><br>Jaime Herrero with Dr. José Fernández Villaseñor                | <b>49</b> |
| <b>Reducing DICOM</b><br>Rodolfo Gonzalez   | <b>54</b> |
| <b>Implementation of an Electrogoniometer</b><br>Leonardo Mangiapelo  | <b>57</b> |
| <b>A Matter of Torque</b><br>Thomas Böhm  | <b>61</b> |
| <b>Position Location Monitoring</b><br>Oziel Hernandez, Varun Jain, Suhas Chakravarty and Prashant Bhargava     | <b>67</b> |
| <b>Beyond Isolation</b><br>Jose Palazzi   | <b>74</b> |
| <b>Low-Cost Driver Assistance</b><br>Suhas Chakravarty, Varun Jain, Nakul Midha and Prashant Bhargava           | <b>78</b> |
| <b>3-D Facial Recognition System</b><br>Deepak V. Katkoria and Alberto Arjona                                   | <b>83</b> |
| <b>Making Industrial Systems Safer</b><br>Dugald Campbell   | <b>88</b> |
| <b>Wireless Sound Notification System for Visually Impaired Persons</b><br>Bogdan Holmanu                       | <b>93</b> |
| <b>Family Product Summaries</b>   | <b>97</b> |

### We want to hear from you!

Send your design ideas, tips or questions to [freescale.com/beyondbits](http://freescale.com/beyondbits).



Inga Harris

# Blood Pressure Monitors

## A Freescale reference design

### Introduction

Digital blood pressure monitors allow physicians to diagnose hypertension (high blood pressure) and help their patients keep it under control. Portable blood pressure monitors help in the early diagnosis and control of hypertension by allowing patients to cost-effectively run tests and measurements at their own homes without having to visit a physician. Home monitoring can also help physicians differentiate white coat hypertension from essential hypertension. Table 1 illustrates how hypertension awareness and control have improved over the years as concluded in the Seventh Report of the Joint National Committee on Prevention, Detection, Evaluation and Treatment of High Blood Pressure (2004).

This article covers the basics of blood pressure monitoring as well as one of the toughest challenges in any measurement system—accurately translating signals from the analog to the digital domain. High-resolution analog-to-digital converters (ADCs) provide good granularity (the ADC resolution is in the nanovolt range) but don't provide high accuracy because the errors are greater. However, various ADC techniques (i.e. over sampling and calibration) can be used to increase the accuracy of results in measurement-based applications.

### Blood pressure monitors

A blood pressure monitor is a device used to measure arterial pressure as blood is pumped away from the heart. Typically, from a user perspective, the monitor includes an inflatable cuff to restrict blood flow and a manometer (pressure meter) to measure the blood pressure. From a system designer's perspective a blood pressure monitor is more complex. It consists of a power supply, motor, memory, pressure sensor and user interfaces, which can include a display, keypad or touchpad and audio, as well as optional USB or ZigBee® communications interfaces.

Figure 1 illustrates Freescale's blood pressure monitor reference design RDQE128BPM, which demonstrates how the sensing, data communication and processing capabilities of Freescale products interact to create a complete medical handheld solution. For more details on this reference design, download the Blood Pressure Monitor Design Reference Manual PDF (search for document number DRM101) from [www.freescale.com](http://www.freescale.com).

Blood pressure varies between systolic (SBP) and diastolic (DBP). Systolic is the peak pressure in the arteries, which occurs near the beginning of the cardiac cycle when the ventricles are contracting. Diastolic is minimum pressure in the arteries, which occurs near the end of the cardiac cycle when the ventricles are filled with blood. Typical measured values for a healthy, resting adult are 115 millimeters of mercury (mmHg) (15 kilopascals [kPa]) systolic and 75 mmHg (10 kPa) diastolic. SBP and DBP arterial blood pressures are not static and undergo natural variations from one heartbeat to another throughout the day. They also change in response to stress, nutrition, drugs, illness and exercise.

### How measurements are made

As the cuff that is wrapped around the patient's arm deflates, small variations in the overall pressure against the cuff (red trace in Figure 2) can be observed. These pressure variations are created by the patient's pulse, which are then amplified through

#### Trends in Awareness, Treatment and Control of High Blood Pressure in Adults Ages 18–74\*

| National Health and Nutrition Examination Survey, Percent |                 |                          |                          |           |
|---|-----------------|--------------------------|--------------------------|-----------|
|   | II<br>(1976–80) | III (Phase 1<br>1988–91) | III (Phase 2<br>1991–94) | 1999–2000 |
| Awareness   | 51              | 73                       | 68                       | 70        |
| Treatment   | 31              | 55                       | 54                       | 59        |
| Control†  | 10              | 29                       | 27                       | 34        |

\*High blood pressure is systolic blood pressure (SBP)  $\geq 140$  mmHg or diastolic blood pressure (DBP)  $\geq 90$  mmHg or taking antihypertensive medication.

†SBP  $\leq 140$  mmHg and DBP  $< 90$  mmHg

Table 1

Sources: Unpublished data for 1999–2000 computed by M. Wolz, National Heart, Lung and Blood Institute; JNC 6.1

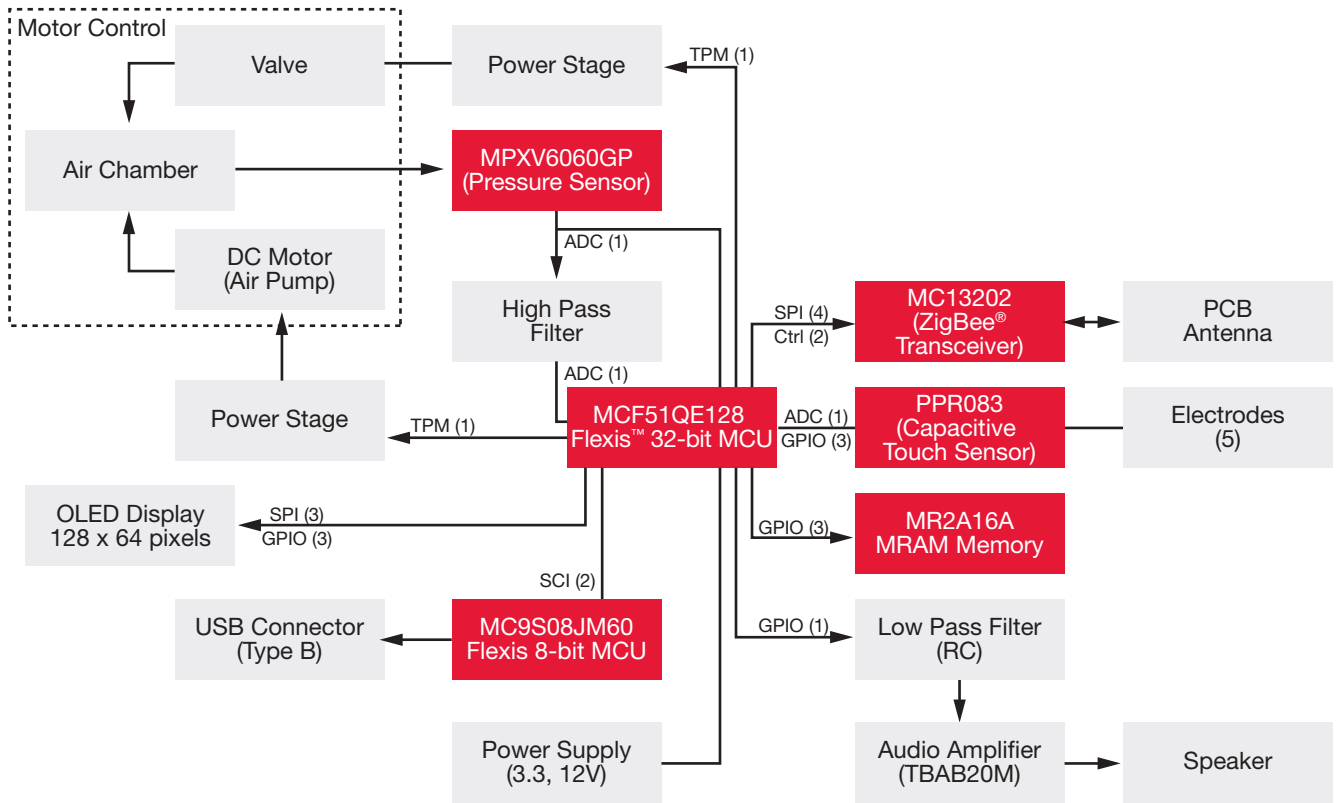

Freescale Technology

Figure 1

a 1 Hz high-pass filter and offset, producing the grey blood pressure trace. This new signal is the heartbeat signal.

Using the heartbeat detection as explained, a simple oscillometric method employed by the majority of automated non-invasive blood pressure monitoring devices is used to determine SBP and DBP. The oscillometric method measures the amplitude of pressure change in the cuff as it is inflated above SBP and then deflated. The amplitude suddenly increases as the pulse breaks through the patient's SBP. As the cuff pressure is further reduced, the pulse amplitude reaches a maximum and then diminishes rapidly. The index of diastolic pressure is taken where this fast transition begins. Therefore, the SBP and DBP are obtained by identifying the region where there is a rapid increase (SBP) then decrease (DBP) in the pulse amplitude. Mean arterial pressure (MAP) is at the point of maximum pressure.

Measuring SBP and DBP can help diagnose hypertension in general, but clinical monitoring alone cannot differentiate between the two common types of hypertension.

## Essential hypertension

Essential (or primary) hypertension is high blood pressure with no identifiable or correctable cause. Essential hypertension is

diagnosed when the SBP is consistently over 140 mmHg or the DBP is consistently over 90 mmHg.

## White coat hypertension

People suffering from white coat hypertension only exhibit high blood pressure symptoms in higher stress environments away from the normal home environment, such as a clinic or physician's office (hence, the "white coat" reference). People with white coat hypertension exhibit high readings (SBP over 140 mmHg, or DBP 90 mmHg) when measured in a clinical environment but have normal blood pressure readings outside the clinic. White coat hypertension can be misdiagnosed as essential hypertension, which can lead to unnecessary treatment and increased insurance premiums. For this reason, medical professionals frequently support home readings over a few weeks to verify a diagnosis. Therefore, portable, easy to use blood pressure monitors are becoming common in the domestic environment.

People with white coat hypertension have a higher risk of developing essential hypertension in the future than those who currently do not suffer from any hypertension. This, along with other risk factors, such as smoking and high cholesterol, has helped drive increased demand for home monitoring kits.

## Heartbeat vs. Diastolic Pressure

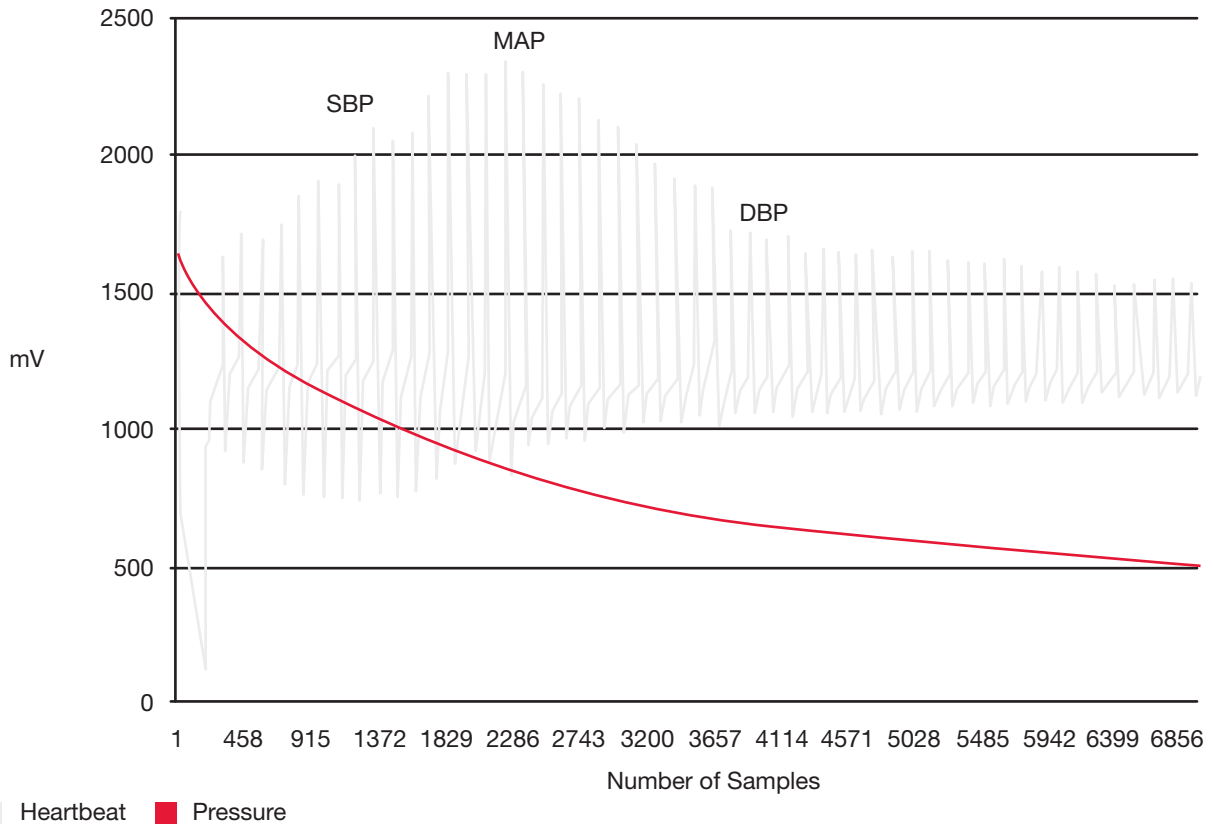

Figure 2

There are a number of drugs available for hypertension treatment, which physicians may choose to use in combination, including:

- ACE inhibitors and angiotensin II receptor antagonists that keep the blood vessels from narrowing
- Alpha blockers and beta blockers, which relax the blood vessels and heart respectively
- Calcium-channel blockers that help expand the blood vessels to ease blood flow
- Diuretics that help rid the body of excess salt and fluids

In addition to following a medical treatment plan, patients must instigate a number of changes in lifestyle and diet and may employ therapeutic relaxation techniques to help reduce hypertension. Regardless of which medical alternative is used or what lifestyle changes are implemented, continual blood pressure monitoring is the common denominator for effective treatment. It is essential that the physician has accurate, up-to-date information so any changes in treatment can be initiated. This means blood pressure monitoring equipment must be available to the patient outside the clinical environment if he or she hopes to lead a relatively normal life.

Compact, easy-to-use blood pressure monitors that require no clinical training to operate are a must if they are to be effectively used by hypertension sufferers while at home or even as they travel. Today's advanced semiconductor technology can provide the basis for more accurate, reliable and cost-effective devices that can help patients better monitor their hypertension so more effective treatment and improved diet and lifestyle changes can be initiated.

### SAR DAC Block Diagram

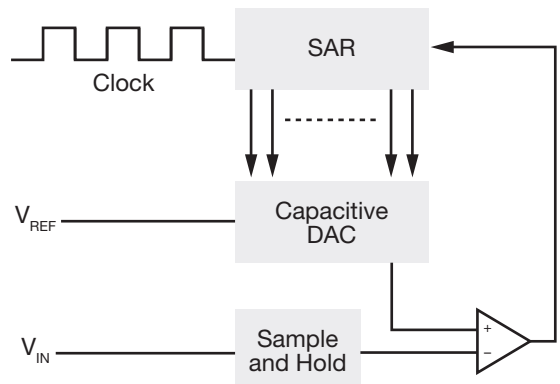

Figure 3



## Analog-to-digital converter accuracy

As illustrated in Figure 1, the microcontrollers (MCUs) and pressure sensor are the core technologies in the blood pressure monitor. The RDQE128BPM reference design block diagram also shows that the most important MCU module in this application is the ADC. Freescale's embedded controller ADC modules are successive approximation ADCs (see Figure 3). These have sample and hold circuitry to acquire the input voltage ( $V_{IN}$ ), a comparator, a successive approximation register sub circuit and an internal reference capacitive digital-to-analog converter (DAC). The DAC supplies the comparator with an analog voltage equivalent of the digital code output from the successive approximation register (SAR) for comparison with  $V_{IN}$ .

Applications like blood pressure monitors have to measure very small signals. Therefore, the ADC resolution is often a key parameter (i.e., 10-bit, 12-bit or 16-bit resolution) and an important factor to consider when choosing an MCU for the application design. Just as important, if not more so, is the ADC accuracy. Bear in mind that all ADCs have built-in inaccuracies because they digitize a signal in discrete steps, a process known as quantization. Consequently, the output cannot perfectly represent the analog input signal. For instance, a 12-bit converter would provide a least-significant bit (LSB) with a 1.22 mV step for a maximum  $V_{IN}$  of 5V. Therefore, the ADC can only digitize values in 1.22 mV steps: 1.22 mV, 2.44 mV, 3.66 mV, etc. In this case, it means a perfect measurement can never be more accurate than  $\pm 0.5$  LSB ( $\pm 610 \mu\text{V}$ ).

Unfortunately, several other embedded ADC characteristics introduce errors and reduce accuracy, including offset, gain, temperature drift and non-linear performance. Some ADCs, such as the 16-bit ADC on some of the newest Freescale Flexis™ products, have the ability to reduce errors in the offset and gain through calibration. Many ADCs have the ability to measure the temperature of the die via an on-chip temperature sensor internally connected to the ADC channels, allowing for temperature compensation to be incorporated.

An ADC's effective number of bits (ENOB) is the true indication of resolution and accuracy. This value shows how many of the bits in a given system provide accurate information. It can be calculated by the following formula:

$$\text{ENOB} = (\text{SNR} - 1.76 \text{ dB})/6.02 \text{ dB}$$

Here, the signal-to-noise ratio (SNR) is the ratio between the meaningful information (signal) and the background noise (noise or error). The SNR value is not only affected by the ADC design and chip integration but also by the layout and design of the printed circuit board (PCB) and by the selection of additional discrete components. A large SNR value means that more of the signal is data and the error is minimal, which,

when measuring signals that change by microvolts, improves the accuracy of the resultant data. Small SNR values mean that the data is distorted by the noise in the system and accuracy is affected. "Noise Reduction Techniques for Microcontroller-Based Systems" (document number AN1705) is one of many resources that can be downloaded from [www.freescale.com](http://www.freescale.com) to help blood pressure monitor system designers mitigate any potential SNR degradation.

## Techniques to improve accuracy

Adding a small amount of controlled noise (0.5 LSB of Gaussian white noise) to an ADC's input, often referred to as "dithering," can force a signal above or below the closest resolution step, which avoids having to round down to the value below. The state of the conversion's LSB randomly oscillates between 0 and 1 rather than staying at a fixed value. Instead of the signal being cut off altogether at this low level (which is only being quantized to a resolution of 1 bit), the process extends the effective range of signals that the ADC can convert at the expense of a slight increase in noise. Effectively, the quantization error is spread across a series of noise values. Dithering only increases the resolution of the sampler and improves the linearity but not necessarily the accuracy. However, a technique that adds 1–2 LSB of noise to a signal with oversampling can increase accuracy.

When adding artificial noise to a signal it is important to remember that the noise must have a mean value of zero. However, many systems have white noise present from other sources, including thermal noise, the CPU core, switching ports and variations in the power supply. Blood pressure monitors are especially prone to white noise as the pump generates electromagnetic interference, vibrations, etc., which are absorbed by the PCB and thus, the microcontroller.

Oversampling is the process of sampling a signal with a sampling frequency significantly higher than the Nyquist frequency of the signal being sampled. In practice, oversampling is used to achieve cheaper higher-resolution ADC conversions. For instance, to implement a 16-bit converter it is sufficient to use a 12-bit converter that can run at 256 times the target sampling rate. For each additional bit of resolution the signal must be oversampled four times. Averaging a group of 256 consecutive 12-bit samples adds 4 bits to the resolution of the averaged results, producing a single result with 16-bit resolution. Because a real-world ADC cannot make an instantaneous conversion, the input value should be constant during the time that the converter performs a conversion. The sample and hold circuitry performs this task by using a capacitor to store the analog voltage at the input and an electronic gate to disconnect the capacitor from the input. Using the ADC setting with the sample and hold time most suited to the input signal will help to improve the result's accuracy.

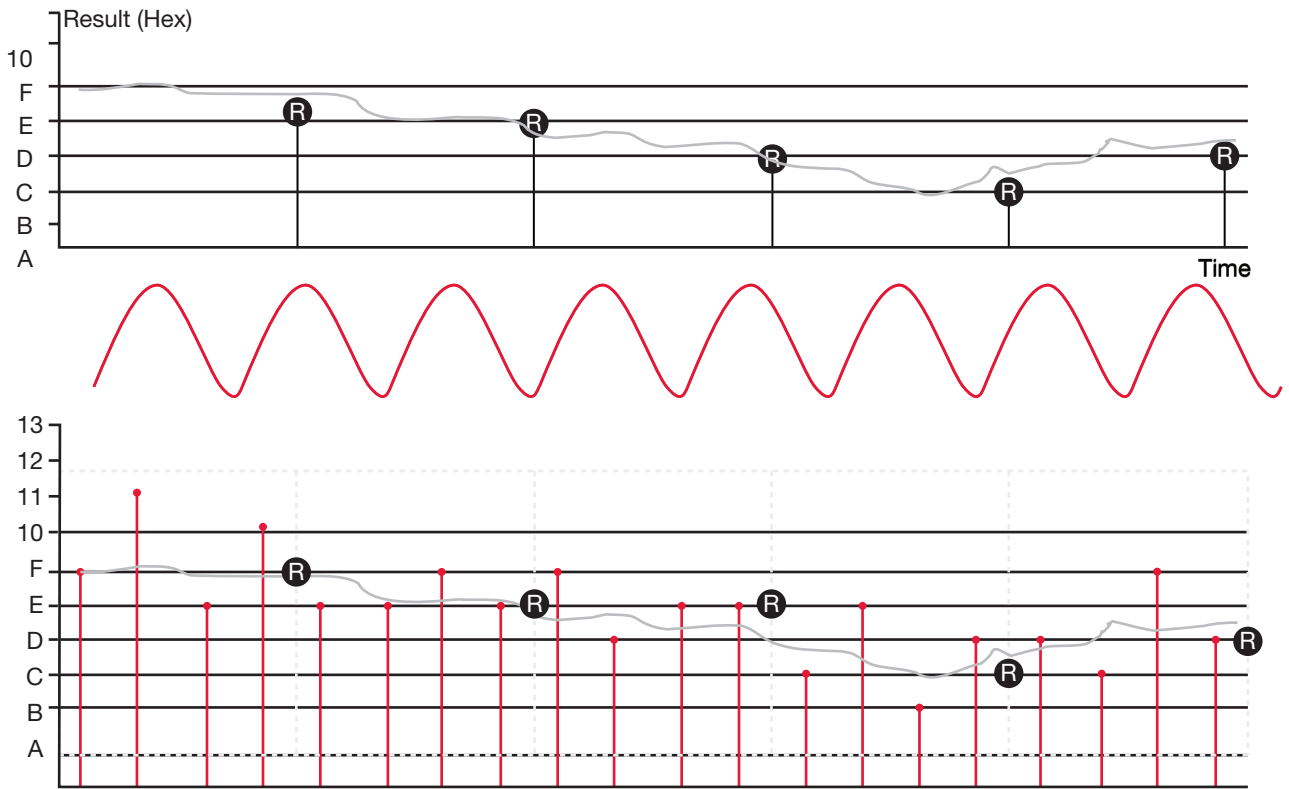

Figure 4

The above two methods, noise injection and oversampling, can be combined to improve accuracy further, as illustrated in Figure 4. This technique is often referred to as oversampling and decimation. The top plot shows the ADC conversion result over time and identifies what the result would be using oversampling alone, without the addition of noise. By adding 1–2 LSB of noise, concurrent samples do not end up with the same result, as shown in the bottom plot in red. This method increases the SNR and enhances the ENOB. By adding the 1–2 LSB of noise to the input signal and oversampling, the results can be averaged to provide a more accurate result. Averaging data from ADC measurements also has the advantage of minimizing signal fluctuation and noise as it flattens out spikes in the input signal.

There are four other manageable sources of inaccuracies: offset, gain, leakage and, to a lesser extent, temperature. Some embedded ADC modules, such as the 16-bit ADC on some of the newest Freescale Flexis products, have a hardware calibration feature that enables repeated calibration during code execution. Embedded ADC modules without hardware calibration can still be calibrated, but this must either be done in the factory or by a solution designed into the product.

Calibration is a three step process:

1. Configure the ADC
2. Initiate a calibration conversion and wait for the conversion to complete
3. Generate offset and gain calibration

The offset and gain calibration values can be subtracted and multiplied respectively to the result. This can be done in software or automatically in hardware on some ADC implementations, such as the ADC16 on Freescale’s latest Flexis products for monitoring applications.

The offset of the input is the easiest of the three sources for which to compensate. For a single-ended input conversion, the input can be referenced against the same voltage internally. This should produce a zero result. If the result is not zero, this is the offset, which must be subtracted from the ADC result. If a differential conversion mode is available, the offset can be found by converting the same signal on both input pins.

Once the offset is known, the ADC’s gain can be found from the full-scale error. This is the difference between the ideal code at the highest output code, such as 0xFFF in a 12-bit ADC, and the actual output code when the offset error is zero.

Figure 5 shows the exaggerated effect of offset and gain on an un-calibrated ramp (black) vs. an ideal ramp (red), from

## Gain and Offset

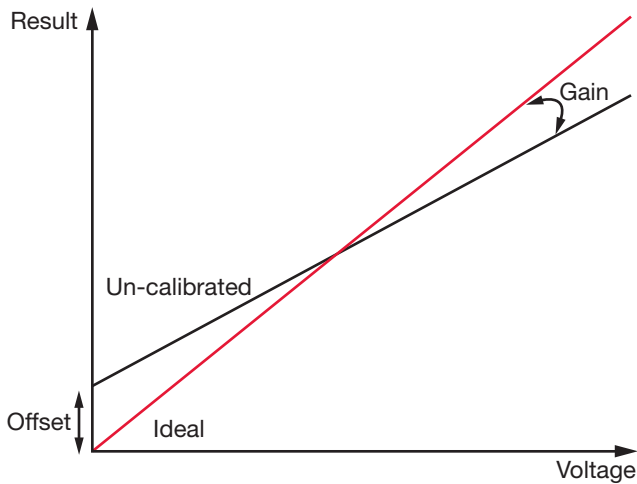

Figure 5

ground to full scale. In applications sensitive to accurate ADC results, such as blood pressure monitors, which are required to identify tiny changes in readings ( $\mu\text{V}$ ), calibration should be done frequently, at least after every reset sequence. If a hardware function does not exist, calibration can be achieved by designing ground and  $V_{\text{DD}}$  inputs into the application, subtracting offset and multiplying by the calculated gain after every set of conversions.

There is another source of input error that is often overlooked but can be significant. Leakage on the input pin can cause the voltage to drop across the resistive portion of the input source. This error can be in the order of tens of LSB in such circuits as battery voltage and temperature detection, which use high value resistive voltage dividers to create the analog reference if the analog DC source resistance is high. The best way to eliminate this error is to reduce the analog DC source resistance and any form of leakage that is within the designer's control. An op-amp that buffers the input voltage can reduce analog DC source resistance.

The temperature of the MCU die can have an effect on the ADC result. This is because the characteristics of the ADC change over temperature, as does the MCU-induced noise, power consumption and frequency. However, temperature is a slow changing factor. Regular recalibration of a blood pressure monitor that has been designed into the application code so the user does not have to be concerned about ideal conditions will help to minimize the effect. However, full in-factory calibration, with results stored in a look-up table in memory, can nearly eliminate temperature effects. Many ADCs have on-chip temperature sensors that can be used to monitor the

temperature so adjustments can be made. Device data sheets will normally specify the temperature sensor slope expressed at  $\text{mV}/^\circ\text{C}$  to indicate the typical characteristic.

Nonlinearity is an error source for which little can be done, since it is normally inherent in the design of the module. The voltage difference between each code transition should be equal to 1 LSB. Therefore, nonlinearity is the irregular spacing of the code steps, which will cause some distortion. Freescale application note "ADC Definitions and Specifications" (document number AN2438, available as a PDF download from [www.freescale.com](http://www.freescale.com)) explains in more detail the difference between integral and differential nonlinearity errors.

## Conclusion

Digital blood pressure monitors help physicians diagnose and help patients control hypertension. Accurate blood pressure monitoring both in the health care facility and the home is critical, particularly when diagnosing white coat hypertension vs. essential hypertension.

The toughest challenge in any measurement system is the translation accuracy of the real-world analog signals to the embedded controller's digital domain. High-resolution ADCs offer good granularity of results (LSB indicates  $\text{nV}$  changes) but do not necessarily deliver high accuracy. Various ADC techniques, such as oversampling and decimation, calibration, leakage control and temperature compensation, can be used to increase the accuracy and the ENOB in a measurement-based application.

Freescale's embedded controller ADCs have high levels of functionality integrated into each device to allow designers to customize them to suit the characteristics of their applications, making high accuracy more achievable. The latest 16-bit ADC in the Flexis product series enables developers to improve accuracy by adjusting the ADC's offset and gain without adding to the system's hardware and software requirements.

Freescale's blood pressure monitor reference design demonstrates how the sensing, data communication and processing capabilities of Freescale's Flexis QE128 and JM controllers, sensors and analog products interact to create a complete medical handheld solution. More details on this reference design are available from the Blood Pressure Monitor Design Reference Manual, which can be downloaded from [www.freescale.com](http://www.freescale.com) (document number DRM101).

Inga graduated from the University of Strathclyde with an honors degree in electronics and electrical engineering. Her technical marketing and applications engineering career has focused on 8-bit and ColdFire MCUs for the consumer and industrial markets. She has published a number of articles and application notes.



Matt Maupin and Raghavan Sampath

# ZigBee® Technology for Long-Term Care

## Improving the quality of life

### Introduction

There are many concerns among businesses today, and health care is high on the list. Health care can affect the bottom line of a business through expensive premiums, reduced productivity and even employee turnover. However, the issues associated with health care are deeper and much more personal than just the financial implications. With two-thirds of people over 65 needing long-term care at some time in their lives and the average duration of need over a lifetime being about three years<sup>[1]</sup>, most of us are likely to be impacted at some point. Thus, quality long-term care is becoming a worldwide concern as life expectancy continues to grow.

Automated monitoring can help improve a patient's safety and quality of life by providing remote decision support from the comfort of his or her home. Unfortunately, most of today's monitoring solutions still restrict a patient's freedom of movement. However, recent advances in wireless technology make it possible to free patients from their equipment, allowing them greater freedom of movement, while providing the caregivers a more cost-effective way to install network connectivity. It makes it possible for health providers to monitor patients who are on the go.

### Long-term care

Long-term care includes a variety of services designed to improve or maintain the quality of life for patients. While there are numerous conditions that can require long-term care, advanced age is the primary reason for seeking long-term care services. In 1900, the life expectancy from birth in the United States was 49.2 years. By 1997, that number had increased to 76.5 years<sup>[2]</sup>. In addition, while 10 percent of the population in 1999 was considered elderly (60 years or older), by 2050, that number will increase to 20 percent<sup>[3]</sup>.

How do we increase safety and improve the quality of life for long-term care patients while optimizing the patient-to-nurse ratio? This is a growing concern among patients, family, caregivers and businesses. In 2000, there was an average of 1.4 million hospice care patients in the U.S. alone<sup>[4]</sup>. The quality of care for these patients varied greatly among caregivers, with 18 percent of nursing home residents complaining of pain and 10 percent having pressure ulcers (bed sores)<sup>[5]</sup>.

Life Expectancy at Birth

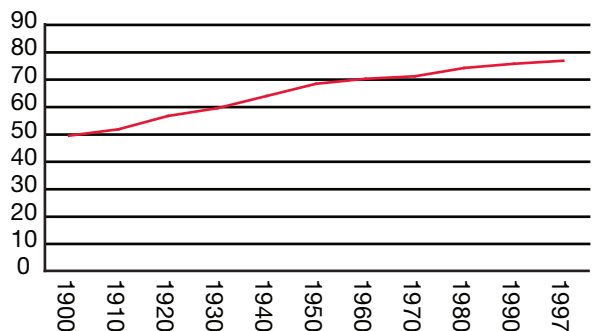

Figure 1

## Comparing ZigBee® Technology to Other Wireless Protocols

| Technology | Pros   | Cons   |
|------------|--|--|
| 900 MHz    | <ul style="list-style-type: none"> <li>• Unlicensed band</li> <li>• Long range</li> </ul>  | <ul style="list-style-type: none"> <li>• Range increases security concerns</li> <li>• Different frequencies for U.S. (915 MHz) and EU (868 MHz)</li> </ul>                                 |
| Wi-Fi®     | <ul style="list-style-type: none"> <li>• Large installed base of equipment</li> <li>• Programmable for worldwide band usage</li> </ul>   | <ul style="list-style-type: none"> <li>• Long packets are less robust</li> <li>• High current consumption</li> <li>• Expensive and large in size compared to ZigBee</li> </ul>             |
| ZigBee     | <ul style="list-style-type: none"> <li>• Low power</li> <li>• Short packets are more robust</li> <li>• Cost effective</li> <li>• Very small size</li> <li>• Globally license free</li> </ul> | <ul style="list-style-type: none"> <li>• Protocol stack required on host</li> <li>• Network coordinator required</li> </ul>  |
| Bluetooth® | <ul style="list-style-type: none"> <li>• Large installed base of equipment</li> <li>• Optimized for ad-hoc networking</li> </ul>   | <ul style="list-style-type: none"> <li>• Seven device limit per piconet</li> <li>• High current consumption</li> <li>• Expensive compared to ZigBee</li> <li>• Range is limited</li> </ul> |

Table 1

### Remote Automated Patient Monitoring System

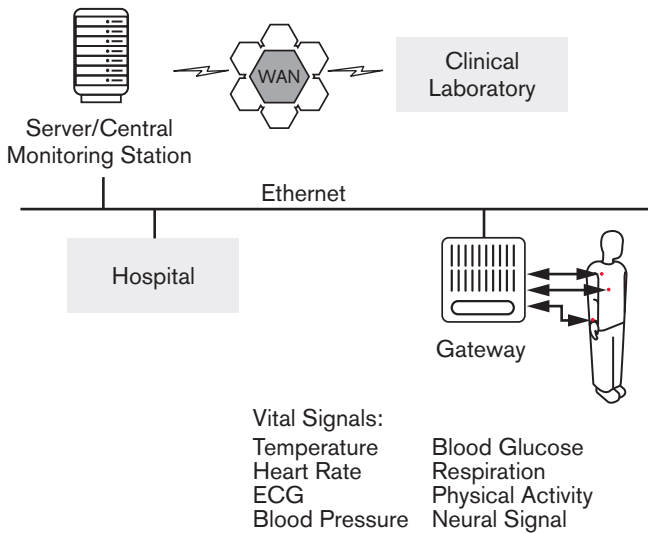

Figure 2

### Patient Monitoring System Wireless Link

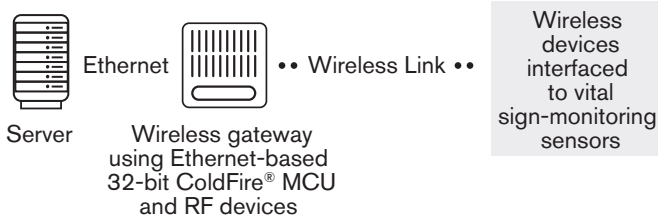

Figure 3

## ZigBee technology and IEEE® 802.15.4

Because the growing need for long-term care is a 21st century issue, it is fitting that we address it with 21st century solutions. For medical care providers, access to timely and accurate information improves the ability to provide the highest quality of patient care. Decision support is not limited to the bedside though, and the quality of care is often dependent on the ability to share vital patient data with clinicians in real time outside the care facility. This means clinicians can provide immediate feedback to attending physicians based on real-life clinical research as well as track treatment paths and results beyond the walls of the hospital over the patient's lifetime to improve future treatment methodologies.

ZigBee technology is rapidly proving to be useful in these applications, helping provide greater freedom of movement for the patient without compromising the automated monitoring functions. By providing low-cost, low-power wireless technology that can cover large buildings and institutions with mesh networking, ZigBee technology can be deployed in a number of products that can help ensure better patient care and more effective tracking of that care.

## Why ZigBee is ideal for wireless vital sign monitoring

A ZigBee network for long-term care consists of a patient monitoring system and the network infrastructure to communicate with a central location or caregiver station as well as other mobile devices. Wireless monitoring provides feedback through a gateway to a central server where data is maintained. This data can be accessed by doctors, nurses and other health care professionals between caregiver visits, alerting them of changing conditions that need attention. Wireless monitoring also allows institutions to track care for accountability and insurance requirements.

## MC1321X Family Block Diagram

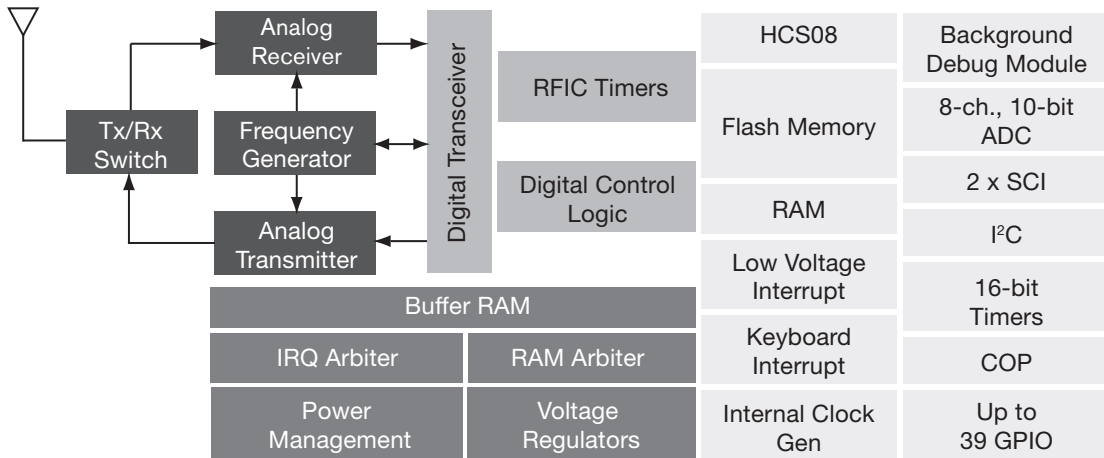

Figure 4

## Remote automated monitoring for long-term-care patients

Remote automated monitoring can be categorized in many ways, including:

- Patient monitoring
- Activity monitoring
- Safety monitoring
- Event capture

Patient monitoring typically checks vital signs, such as heart rate and temperature, and disease indicators, such as blood pressure and blood glucose levels. ZigBee can be used to transmit data to a network gateway, updating the staff or notifying them when a certain threshold is passed. An automated monitoring system could even be designed to take specific actions. For example, blood glucose levels could be monitored and recorded at pre-set intervals. If the glucose level rises above a specific threshold, insulin could be delivered automatically.

Activity monitoring records daily activity. The data logging can then be used to interpret changes. This can be as simple as tracking movement data from an acceleration sensor during daily activity or an exercising session. This reading can be compared with vital information from patient monitoring, such as the heart rate, to determine how much effect a certain amount of physical activity has on the body. This activity can be tracked over any length of time and then compared to historical data to identify certain trends. Activity monitoring can even be used to remind the patient when to perform an activity or alert the caregiver if the activity has not taken place.

Safety monitoring targets the notification of events, or potential events, that have affected, or could affect, a patient's safety. It can be tied to both patient monitoring and patient activity to provide notifications of such events. For example, if a patient leaves a certain area, an alert can be sent to the caregiver so the patient can be located.

Event capturing records events associated with the patient and caregiver responses. This is critical information for health care records and ensures that information on events and actions can be quickly retrieved and reviewed.

## MCF5223x Family Block Diagram

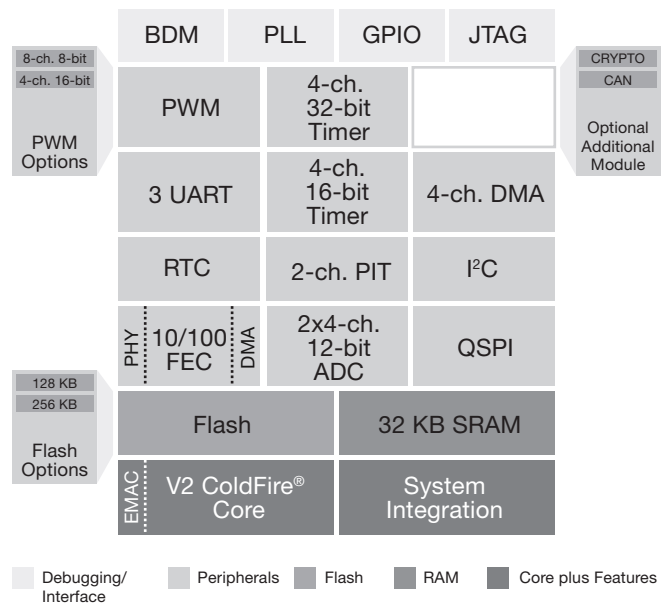

Figure 5



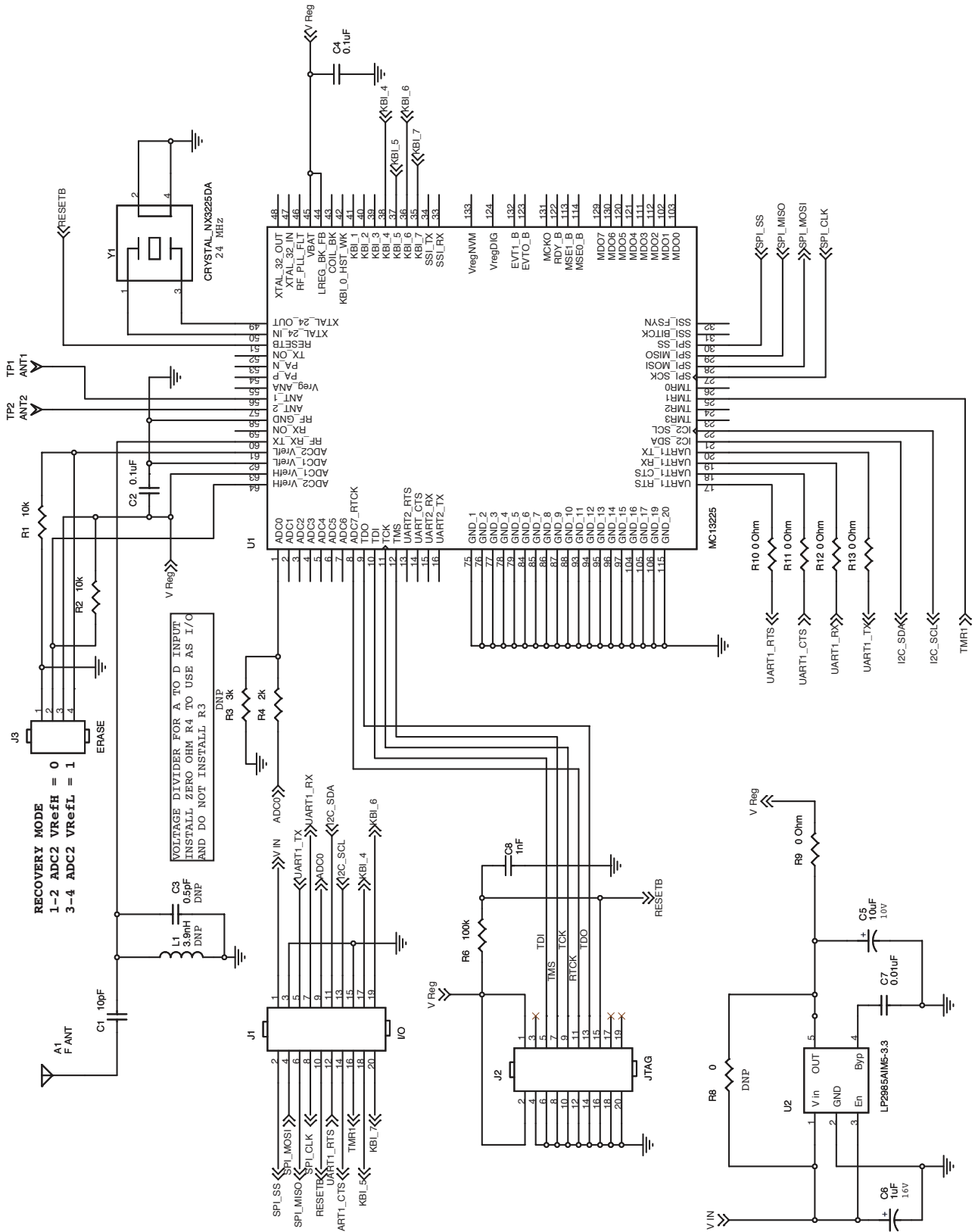

Figure 6

## Freescale enables ZigBee technology for medical devices

Freescale's family of ZigBee technology solutions provides the perfect combination of low cost, low power, high integration and high performance that is required for medical monitoring applications. These solutions include the 8-bit MC13213 system in package (SiP), 32-bit MCF5223x ColdFire® embedded controller and the 32-bit MC13224 Platform in a Package™ (PiP) solution.

The MC13213 SiP integrates the MC9S08GT microcontroller (MCU) with the MC1320x RF transceiver into a single 9 x 9 mm LGA package. The MC13213 SiP provides 60K flash memory and 4K of RAM. By using the IEEE 802.15.4 compliant MAC or ZigBee protocol stack, the MC13213 SiP is an excellent solution for sensing and controlling applications that require mesh networking.

The MCF5223x family of ColdFire devices includes single-chip solutions that provide 32-bit control with an Ethernet interface. It combines a 10/100 fast Ethernet controller (FEC) and Ethernet physical layer (EPHY) with the V2 ColdFire core for exceptional performance at a reasonable cost. The MCF52235 embedded controller provides the designer with the right set of peripherals and memory size for a compact Ethernet-enabled platform that cuts development time and cost to help move products to market more quickly.

Freescale's third-generation MC13224 device is the ideal platform for enabling ZigBee technology in products for medical applications. It provides key technology enhancements for reduced size and a lower product cost, which are important considerations for body-worn devices. The highly integrated low-power design provides long battery life and requires only an external power source and a 50 ohm antenna to complete the solution. The 32-bit ARM7™ core processor with plenty of additional memory allows the device to run both the ZigBee stack and the application on a single IC.

Freescale's ZigBee solutions include not only silicon but also software, development tools and reference designs to help simplify development. Freescale's BeeStack™ ZigBee-compliant stack with BeeKit™ Wireless Toolkit provides a simple software environment to configure network parameters. This tool allows customers to use a wizard and drop down menus to help configure the ZigBee network parameters, whereas competing solutions force the user to wade through lines of code to edit the network parameters.

While such a solution as the MC13224 PiP simplifies RF design, many customers do not have the expertise to ensure robust and optimized designs. So Freescale has done much of the work for them, compiling a number of reference designs where customers can take the BOMs, Gerber files and schematics and simply copy a design and integrate it into their product<sup>(6)</sup>. The complete platform approach is provided to help the customer reduce development time and speed time to market.

### Application example: RF Technologies®

One of Freescale's customers, RF Technologies, is a leader in providing solutions that enable health care providers to monitor patients. The company has developed a number of products based on ZigBee technology that are used to improve the health and safety of patients while providing tracking and accountability for the providers. For example, the Code Alert® Integrated Care Management Solution includes Emergency Call Pendants for patients to wear that allow them to alert the staff if they need assistance. Software tracks the alert, and the emergency notification can be sent to a computer or to any number of mobile devices in the system, displayed as an e-mail or text message. When the staff member arrives to provide assistance, the pendant can be depressed in a specific code sequence to log the event and the response into the system. This helps caregivers ensure that proper care is given on time, and it provides response time and incident location so facility or administrative personnel can measure accountability.

RF Technologies adopted ZigBee technology for its low-cost, high-reliability and low-power-consumption benefits. James Herman, vice president of business development said that "ZigBee is the perfect match for our data capture, bandwidth and communications requirements. No other standard provides the same benefits, and ZigBee works well in our customers' environments. Customers also want standards-based platforms and are tired of proprietary systems that cost them more and lock them into single-source relationships."

## Summary

An aging population and long-term medical care will continue to be serious issues in our society. Advancing technology helps address the need to improve the quality of life for patients, and ZigBee wireless technology enables designers to bring new ideas to reality. By providing a low-power wireless solution that can be used with patient activity and safety monitoring solutions, ZigBee technology offers patients more freedom to do what they want and provides caregivers a number of key advantages, including:

- Cost-effective and scalable sensor networks to address critical bottlenecks in the emergency response process
- Real-time notification of drug infusion protocols that violate accepted hospital practice, thus eliminating preventable adverse drug events
- The opportunity to improve treatment protocols
- Remote access to real-time patient data for physicians in their offices
- Real-time analysis of drug effectiveness
- Network management of all connected medical devices
- Real-time changes in patient care to reduce costs and improve care

Through our leading ZigBee technology solutions, Freescale can enable customers to design new products that can help them grow in a rapidly expanding health care market and improve the daily lives of long-term care patients.

## References

- [1] Kemper, P., Komisar, H.L., and Alecixh, L., "Long-Term Care Over an Uncertain Future: What Can Current Retirees Expect?" *Inquiry* 42(4):335-350, 2005
- [2] National Vital Statistics System
- [3] National Vital Statistics System
- [4] National Center for Health Statistics Advance Data No. 297
- [5] NCHS Nursing Home Current Residents, June 2008
- [6] [www.freescale.com/webapp/sps/site/overview.jsp?code=ZIGBEE\\_REFERENCEDESIGN\\_HOME](http://www.freescale.com/webapp/sps/site/overview.jsp?code=ZIGBEE_REFERENCEDESIGN_HOME)

Raghavan Sampath joined Freescale in 2006. He has over nine years of experience in the semiconductor industry focusing on application support and business development. Matt Maupin joined Freescale in 2001. He has over 15 years of experience in the high tech industry, focusing on wireless connectivity, including Wi-Fi, Bluetooth, 802.15.4 and ZigBee technology. He has a Bachelor of Science degree in management and marketing from Park University.



Donnie Garcia and Alejandra Guzman with Dr. Claudia Rentería Govillo

## Gestational Diabetes

### Technology can help reduce complications

#### Introduction

Freescale’s advances in low-power technology and mixed-signal integration have led to more flexible microcontrollers (MCUs) that feature key peripheral blocks useful for pregnancy monitoring applications, including those for gestational diabetes. In all areas that are important to medical applications—low power, mixed signal integration, display and connectivity—Freescale is delivering the enhanced technology needed for next-generation medical system solutions.

#### Gestational diabetes

Pregnant women who are not diabetic can still develop high blood sugar (glucose) levels during pregnancy. This is called gestational diabetes, and it affects between one and three percent of all pregnant women. Essentially, the increased production of hormones during pregnancy can lead to insulin resistance, which means insulin cannot effectively lower blood glucose levels. This forces the body to produce more insulin to compensate, which can lead to gestational diabetes.

What’s more, even though any woman can develop gestational diabetes, some are at greater risk than are others, including those:

- Older than age 25
- With a family history of diabetes, or those who have had gestational diabetes in a previous pregnancy
- Who have delivered a baby who weighed more than nine pounds or have experienced an unexplained stillbirth
- Who were overweight before pregnancy

In addition, for reasons that aren’t clear, Hispanic, American Indian, Asian and black women are more likely to develop gestational diabetes than are other women. And for women already suffering from diabetes, excellent blood glucose control before conception and throughout pregnancy is vital not only for the health of the mother but for that of the baby as well.

During gestational pregnancy, if the glucose levels are not well managed, extra blood glucose passes through the placenta and raises the baby’s blood glucose levels. This can increase the baby’s body fat and lead to macrosomia (a baby weighing more than nine pounds 15 ounces at birth). Macrosomic babies face their own health problems, including increased risk for breathing problems, child obesity, developing type 2 diabetes and even physical injuries during childbirth.

For all these reasons, accurate blood glucose testing before or early in the pregnancy is essential for quick diagnosis and treatment of gestational diabetes (see Figure 1), particularly since most women will not exhibit early symptoms normally associated with diabetes (excessive thirst and increased urination).

Initial diagnosis may involve an oral glucose tolerance test. This is generally performed in a clinical environment and requires the patient to drink a glucose solution, which is then followed by blood glucose monitoring at specific intervals (see Table 1). However, continual monitoring for diabetic maintenance once the diagnosis has been established is most conveniently done at home, hence the need for accurate home devices.

#### Example of Oral Glucose Tolerance Test (OGTT)

|            |               |
|------------|---------------|
| Fasting    | 95 or higher  |
| At 1 hour  | 180 or higher |
| At 2 hours | 155 or higher |
| At 3 hours | 140 or higher |

Note: Some labs use other numbers for this test

\*These numbers are for a test using a drink with 100 grams of glucose

Table 1

Advanced semiconductor technology from Freescale, with low power, mixed signal integration and display and connectivity interfaces, make it possible to design small, easy-to-use devices that are ideal solutions for home blood glucose monitoring.

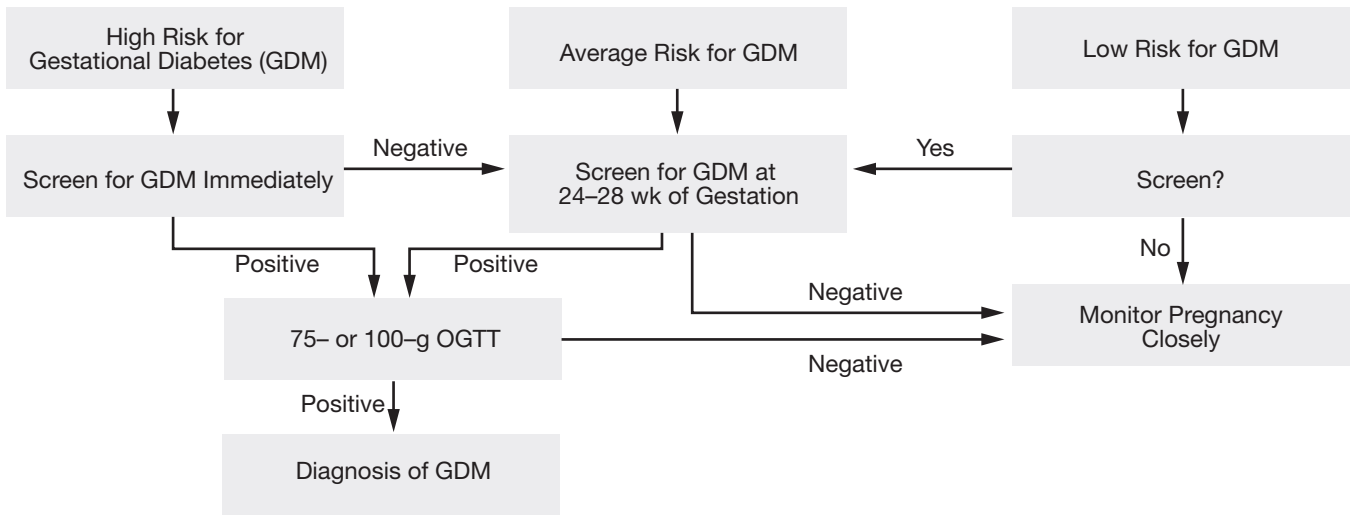

Figure 1

Source: Am J Health-Syst Pharm © 2004 American Society of Health-System Pharmacists

## Freescale highly integrated low-power solutions

Combining ultra-low-power platforms with high precision analog peripherals, Freescale has made great strides toward realizing total system solutions for automating many of the application functions in the developing pregnancy monitoring market. Freescale’s MCUs can enable significant cost benefits for glucose meter designs, thus providing the benefit of glucose level tracking for more mothers to be.

There are several key focus areas that are important to a wide range of portable medical applications:

- Low power
- Mixed signal integration
- Display technology
- Connectivity

Freescale is delivering the advances needed to enable medical market customers to optimize their products for each of these areas.

### Ultra-low-power platform

Freescale MCUs utilize innovative technology to achieve the absolute lowest power for such applications as portable medical devices. The low-power performance of each of the following MCUs makes them ideal for portable medical devices.

- MC9S08LLxx: Cost-efficient entry-level MCU with LCD driver and excellent power consumption
- MC9S08QExx: Best-in-class power consumption for sensor development and medium processing performance at a great price
- MCF51QE: Excellent performance and low-power features. Pin-to-pin compatibility with 9S08QE controllers makes it ideal for enabling medical devices to scale in complexity and functionality

All of these devices contain four main features that are the foundation of low-power operation.

### Low-power crystal oscillator

The crystal oscillator is optimized for driving crystals at low power with options for low or high gain modes. This peripheral consumes less than 500 nA for a 32.768 kHz crystal when in low-power modes. With the low-power crystal oscillator, accurate time can be kept while the MCU is in a standby power mode (Stop mode).

## Freescale Low-Power MCU Modes of Operation

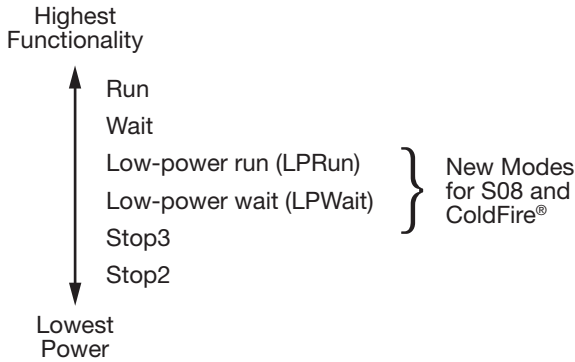

Figure 2

### Modes of operation

The energy-efficient MCUs have multiple modes of operation, each tailored to a specific level of functionality to allow the most efficient performance/power consumption tradeoffs. The modes of operation (run, lprun, wait, lpwait, stop2 and stop3) support power consumption as low as 250 nA for some devices and enable medical applications to continuously operate with the highest energy efficiency. The modes of operation also enable many of the MCU's peripherals to operate in low-power run mode to provide the right functionality mix in a low-power mode.

### Flexible clock source

Related to the benefits provided by the operating modes, the internal clock (ICS) peripheral on the energy-efficient solutions provides the ability to ramp up or ramp down the device's operating frequency. Higher operating frequencies lead to higher run-mode power consumption. Depending on the application requirements, running at a lower operating frequency will allow

the power to be reduced by about 500  $\mu$ A per Mhz. The ICS will allow the embedded developer to fine tune the MCU's performance to optimize power consumption.

### Clock gating

In order to further reduce run-mode power consumption, each of the peripherals on the low-power platform has the ability to be clock gated. Clock gating is a method of shutting down the clock signal that is routed to a peripheral. Though clock gating a single peripheral only reduces power consumption by tens of microamps, when reaching for the lowest power possible, it is essential to reduce every unneeded internal trace and clock signal. When disabling clocks to all peripherals, clock gating has been measured to reduce run mode power consumption by almost one third.

## Glucose meter application using Freescale solutions

Utilized together, the features described in the previous section can optimize a portable medical design, such as a blood glucose meter, for more energy-efficient operation.

The low-power oscillator is used to deliver very low standby power consumption while keeping accurate time. This will allow the glucose meter to keep accurate records of measured glucose levels for historical purposes.

Using the flexible modes of operation and the ICS, the glucose meter firmware can be designed so that during the complex calculations necessary to produce a glucose measurement the MCU performance can be increased in order to shorten the processing time, thereby improving the user experience.

Finally, additional power savings can be achieved with the clock gating technology. Using all the low-power techniques together

## Blood Glucose Meter Block Diagram

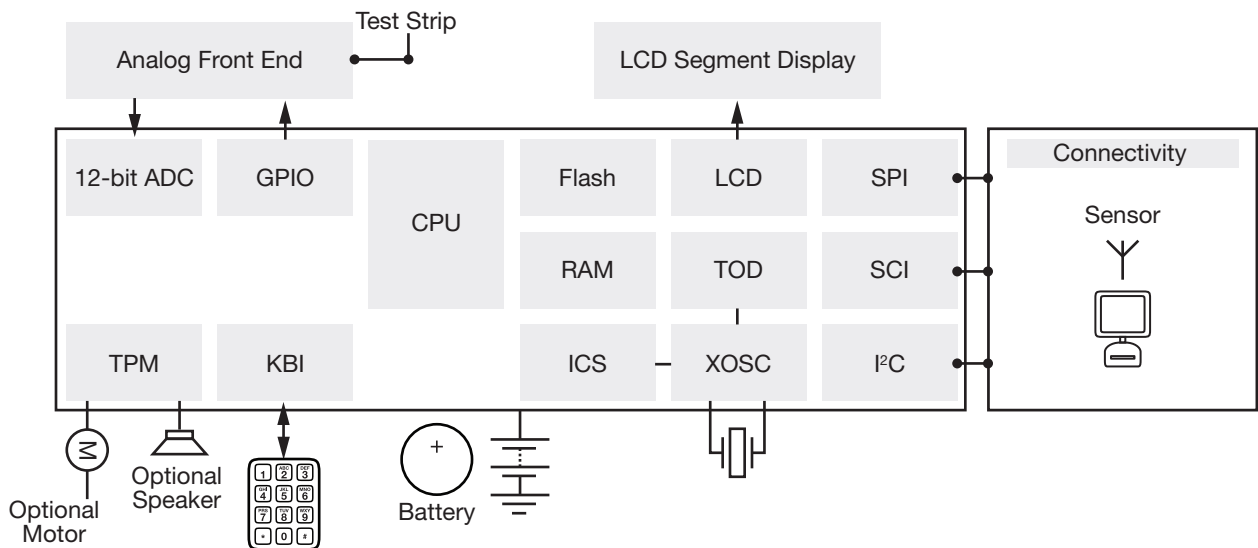

Figure 3

will allow the meter to function much longer on a single battery charge, and it will enable developers to use a smaller battery, thus enhancing portability and the user experience.

### Mixed signal integration

Essential to a glucose meter design is the ability to make small signal analysis of the electro-chemical reaction initiated by a glucose measurement. One stage of the analysis is recognizing the peak of the biosensor's electrical output. Utilizing the analog comparator (ACMP) peripheral, the Freescale MCU can be configured to trigger an interrupt once the peak has been reached.

The next stage requires precisely timed analog-to-digital conversions of the glucose meter strip's linearly decaying output. Many Freescale devices contain a feature-rich 12-bit analog-to-digital converter (ADC) that enables these measurements. The ADC has features, such as automatic compare and flexible conversion time settings, that are ideal for this type of analysis.

Finally, the CPU (8-bit or 32-bit) is used for the mathematical analysis. The chemical reaction between the sample (blood) and glucose meter strip produces a linearly decaying signal that is processed across a couple of seconds. The CPU performs some filtering of the input signals over time using average routines or the more complex IIR filtering. The average is taken at several points along the input signal's linear decay, from which the slope of the linear decay is calculated. It is this slope that will directly correlate to a specific value for the blood glucose level.

The on-chip integration of analog functionality on Freescale MCUs provides many system cost benefits. The obvious benefit is that it decreases the need for external ICs, thus reducing the BOM and board space. But on-chip analog also features low-voltage detection and internal bandgap reference voltages, which further lower overall cost.

### Blood Glucose Meter Software Flow Chart

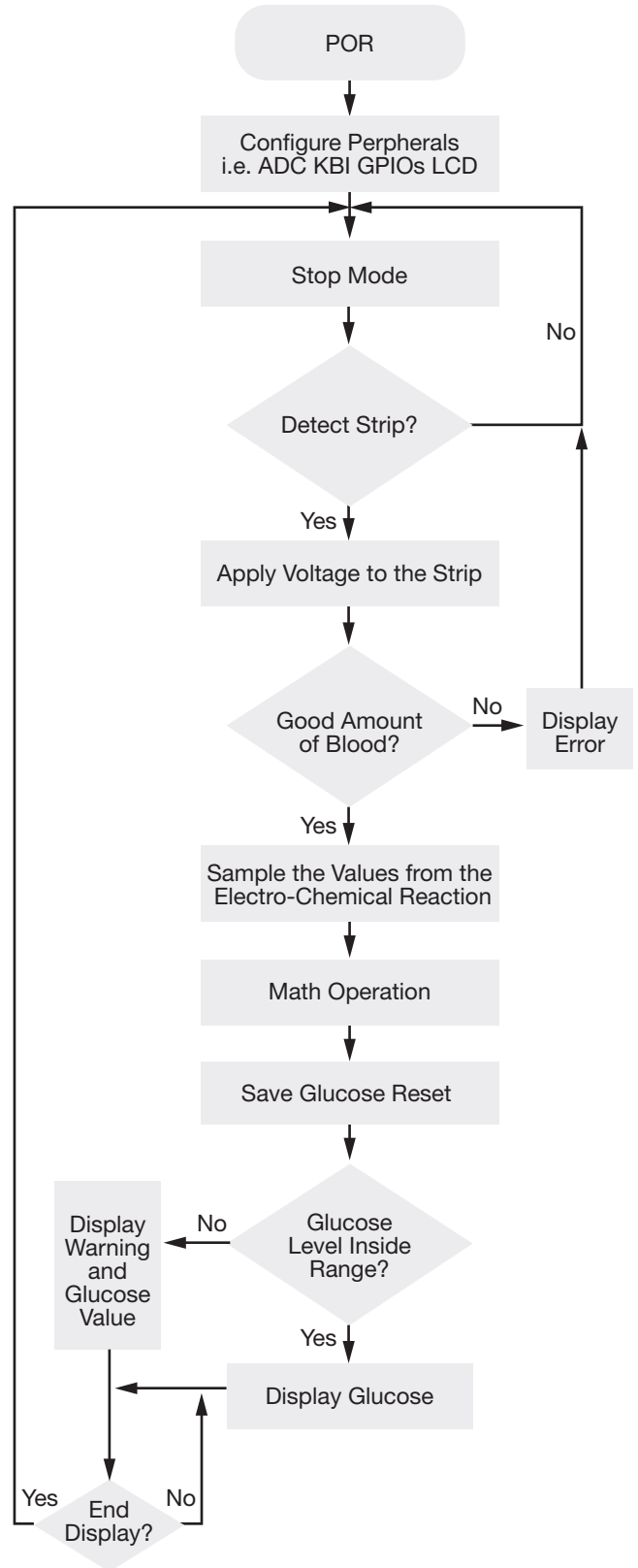

Figure 4



## Display capabilities

With the launch of the L family of 8-bit MCUs with integrated LCD peripherals, Freescale provides the ideal display functionality for portable medical devices. The LCD peripheral on these devices contains key features that will reduce cost and provide more functionality for glucose meters.

First, Freescale has added the ability to assign front plane (segment) or backplane (common) functionality on any of the MCU's pins. With this feature, signal layout can be optimized so that PCB board space can be reduced. This feature also allows quick changes of LCD glass design because the hardware change can be handled by a software update. An excellent example of a flexible LCD driver is described in the Freescale application note, LCD Driver Specification, which can be downloaded as a PDF from [www.freescale.com](http://www.freescale.com) (document number AN3796).

Second, the new LCD peripheral has the ability to drive more segments with fewer pins, utilizing x8 muxing of the LCD signals. With this function it only takes 28 pins (8 x 20) to drive 160 LCD segments. The same functionality requires 44 pins on many competing devices. By using fewer pins, board size and connector space are reduced, enabling more compact portable medical designs.

Finally, the LCD peripheral architecture is designed to provide the most energy-efficient performance. Low power was considered for every aspect of the design. The end result is the ability to drive LCD glass with total system power as low as 1.5  $\mu$ A with LCD glass connected. This performance, along with low-power blinking mode (the ability to blink the display while in stop mode), allows product developers to lower average power consumption by up to 70 percent for their portable medical designs. This will lead to significantly longer battery life and further cost reductions in the types of batteries needed for the end device.

In glucose meter designs, a visual display is mandatory for patients to be able to read the metering results. With Freescale's S08L family, LCD functionality and best-in-class power consumption can be achieved with a single device. Freescale also provides software routines that allow easy glass customization and fast LCD GUI development. In addition, by consulting the LCD Driver Specification application note, designers can reduce their overall development time.

## Connectivity

The ability to transfer information from the blood glucose meter to a computer for analysis is an important option for new meter designs. Freescale MCUs integrate key peripherals essential for providing this connectivity, such as SPI, SCI and I<sup>2</sup>C, that allow data transfers within systems. Using the SPI, the MCU can easily connect to a ZigBee<sup>®</sup> transceiver to provide flexible, low-power wireless connectivity.

## Conclusions

Freescale's advances in low power and mixed signal integration have led to the development of MCUs that feature key components for glucose monitoring applications used during the diagnosis and treatment of gestational diabetes. Though current Freescale devices provide many benefits, the company is dedicated to further improve low power, mixed-signal integration, display and connectivity features to benefit the pregnancy monitoring market.

## Bibliography

[www.diabetes.org](http://www.diabetes.org)

[www.diabetes.niddk.nih.gov/dm/pubs/gestational/](http://www.diabetes.niddk.nih.gov/dm/pubs/gestational/)

Gestational diabetes: Test and diagnosis—[www.mayoclinic.com](http://www.mayoclinic.com)

[www.familydoctor.org/online/famdocen/home/women/pregnancy/complications/075.html](http://www.familydoctor.org/online/famdocen/home/women/pregnancy/complications/075.html)

Donnie and Ale both support Freescale's Microcontroller Solutions Group. During Donnie's 10 years with the company, he has worked as an applications engineer supporting 8-bit MCUs and has been heavily involved with the product definition of the new S08 MCUs. Ale has supported customers through Freescale's Technical Information Center (TIC) after collaborating for systems and solutions engineering, working on medical applications. Dr. Rentería has been an attendant for the gynecology and obstetrics service for more than ten years with expertise in high-risk pregnancy.

Shen Li, Ju Yingyi with Dr. Gabriela López and Dr. Sergio Rosales

# Sports Game Station

## Exercise, entertainment and seizure detection

### Introduction

Today, more and more people are participating in sports, pedaling a stationary bicycle or running on a treadmill to remain fit. However, at the same time more children are forgoing physical exercise and spending more time playing video games. Not only can the lack of exercise lead to weight gain, but the visual nature of high-speed video games can lead to pediatric seizures in children with photosensitive seizure disorder.

The seizures can be induced by photic stimulation (flicker) or by spatially periodic patterns<sup>[1]</sup>. These stimuli are found in multiplayer online role-playing games, small handheld games, video or television games and special game consoles<sup>[2]</sup>.

Recognizing the risk, international organizations, including the International Telecommunication Union (ITU) and the International Organization for Standardization (ISO), have begun to consider international guidelines for photic and pattern stimulation in public media to help protect such individuals<sup>[1], [2], [3], [4]</sup>.

Freescale has built a wireless game controller demonstrator that combines a stationary exercise bicycle with video game technology to help people stay fit while playing their games. What's more, by integrating a ZigBee® transceiver and a three-axis low-g microelectromechanical system (MEMS) accelerometer, the Freescale Sports Game Station (SGS) is designed to detect evidence of conditions such as a pediatric seizure and wirelessly transmit an alert signal to parents or other caretakers. The concept is designed to help make video game playing healthier and safer.

### Pediatric seizures epidemiology

For some time, viewing television and video games has been linked to photosensitive epileptic seizures. In Japan in December 1997, a televised Pokemon animated program reportedly induced seizures in a number of children. The investigation was narrowed down to a section of the show that included a 15 Hz alternating red and blue flashing light. This tended to confirm previous reports that children with photosensitive seizure disorder are particularly affected by flashes of very-long-wavelength monochromatic lights. In the 1999 study, "Photosensitive Epilepsy and Image Safety," the authors concluded that video game display flicker, intermittent photic stimulation (IPS) at 50 Hz, may underlie the seizures suffered by game players with photosensitive seizure disorder<sup>[3], [5]</sup>.

### Reducing the risk of pediatric seizures

Programmers can help reduce the risk of video game-induced seizures by eliminating such IPS instances as opposing changes in luminance between pairs of flashing lights and transition to or from saturated red, and by limiting flashing sequences to no more than three per second.

To help players lessen the risk of seizure, the Epilepsy Foundation recommends:

- Sitting at least two feet from the screen in a well-lit room.
- Reducing the brightness of the screen.
- Not allowing children to play video games if they are tired.
- Taking frequent breaks from the games and looking away from the screen every once in a while. Do not close and open eyes while looking at the screen as blinking may facilitate seizures in sensitive individuals.
- Covering one eye while playing, alternating the covered eye at regular intervals.
- Turning the game off if strange or unusual feelings or body jerks develop.

# Freescale Sports Game Station: combining exercise, entertainment and seizure detection

## Station Diagram



Figure 1

SGS has two parts, one is a station and the other is an endpoint. On the station board (Figure 1), there is a 32-bit MCF51JM128 microcontroller (MCU) based on the V1 ColdFire® core with integrated USB On-The-Go and an MC13192 short-range, low-power 2.4 GHz industrial, scientific and medical (ISM) band transceiver.

## Endpoint Diagram



Figure 2

The endpoint board (Figure 2) includes an ultra-low-power 8-bit MC9S08QE32 (S08QE32) main control chip, an MC13192 low-power 2.4 GHz wireless transceiver and the MMA7260QT 3-axis, low-g MEMS accelerometer.

As part of the complete system (Figure 3), the endpoint is attached to the player's body or activity equipment to record movement. The accelerometer senses motion (specific human action) and converts the action to an analog electronic signal. The MCU (S08QE32) reads the analog signal and converts it to a suitable keyboard key value. After that, the MCU sends the key value to the wireless transceiver through the SPI port and directs the wireless transceiver to transmit the data to the station. When the transceiver on the station board receives a key value data packet, it alerts the MCU (MCF51JM128), which reads the data through the SPI port and sends the key value to a PC via a USB cable. Thus, the PC can recognize human actions as a keyboard value.

In this example, the endpoint acts as a sensor that transmits activities and motions to the station while the station acts as a USB human interface device class (USB HID) keyboard device. When connected to a PC, it is recognized as a simple

freescale.com/beyondbits

## SGS System Overview

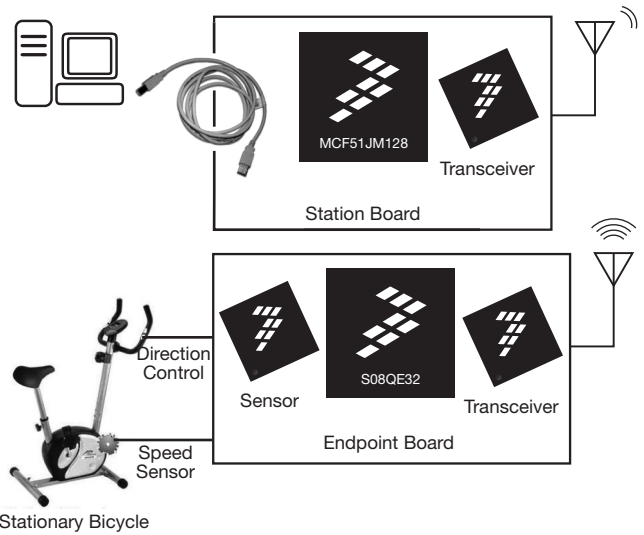

Figure 3

USB keyboard, enabling many popular keyboard or joystick controlled video games to use this system as its controller. For different game controllers, this platform is able to use different movement sensors, simple buttons or joysticks. For instance, Freescale's 3-axis low-g MMA726x accelerometers are already used for tilt detection in some well-known PC games. For stationary bicycles, the speed sensor and direction control keys can be adopted. For a wrestling game, a joystick can be used as a direction controller and the accelerometers sense the punching and kicking motions.

## Using the endpoint sensor to detect seizures

Adding significant value to the Freescale's SGS, the endpoint can be used to provide some peace-of-mind for players with photosensitive seizure disorder. The same endpoint hardware can be used, requiring only a different software implementation that can recognize a seizure event. A seizure may occur when a brief, strong surge of electrical activity affects part or all of the brain. Seizures can last from a few seconds to a few minutes and can exhibit many symptoms, from blank staring, lip smacking or jerking movements to more dangerous convulsions and loss of consciousness.

To detect evidence of conditions such as a seizure, a reliable algorithm is necessary. This special algorithm must be designed using enough samples of seizure waveforms (caused by jerking body movements) gathered by the accelerometer to ensure exceptional accuracy. Once the seizure information is transmitted to the station and, in turn, sent to a computer, a software program running on the PC can alert parents through an automatic text message to their cell phones or a buzzer alarm in the game console that an unexpected seizure has occurred. This data could also be submitted to a neurologist to verify the waves and confirm any abnormal activity.

## Long battery life

Because the SGS endpoint is a wireless game controller, power consumption is an important design consideration. All three of the primary components exhibit exceptional low-power performance: the ultra-low-power S08QE32 MCU (about 0.4  $\mu$ A in STOP mode), MC13192 wireless transceiver and the MMA7260 low-g accelerometer (about 3  $\mu$ A in sleep mode). In addition, if there is no signal detected by the sensor within several minutes, the endpoint itself will enter sleep mode to conserve battery life.

### Software Overview Diagram

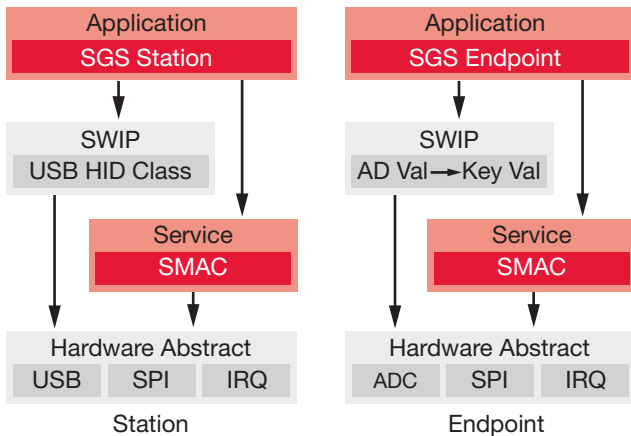

Figure 4

## SGS firmware

It is easy to program the firmware for both the station and endpoint (Figure 4). The station includes a USB driver, USB-HID keyboard protocol and simple multimedia access controller (SMAC) protocol. (For more details on the USB driver and USB-HID class for ColdFire MCUs, please refer to the CMX\_USB-LITE stack, available at [www.freescale.com](http://www.freescale.com)).

For the endpoint, a SMAC and a simple algorithm translates tilt, movement, direction and speed signals into a keyboard or joystick where values are needed. The endpoint's MMA7260QT accelerometer outputs variable voltage levels to X, Y and Z output pins when it detects a tilt, movement or acceleration. The ADC module in the S08QE32 MCU reads the voltage level outputs and converts them to digital values that can be recognized as movement activity. And with the SMAC protocol, any simple data packet can be easily sent or received effectively.

## SMAC

SMAC is an uncomplicated software protocol based on the IEEE® 802.15.4 protocol that works with Freescale's transceivers with 8-bit MCU control. It is free of charge from Freescale and is intended to be used for fast product development and system evaluation. SMAC is simple and easy to use because it implements neither the full ZigBee stack nor the complete 802.15.4 layer. SMAC is ideal for low-cost applications that require basic primitives, such as transmit, receive and power and channel selection. For more details on SMAC, please refer to the stack reference manual (search for SMACRM) at [www.freescale.com](http://www.freescale.com).

## Conclusion

Freescale has the necessary technology to develop a sophisticated gaming system to provide entertainment, promote fitness and detect photosensitive seizures. Wireless transceivers (MC1319x/1320x family) and free stacks (SMAC), accelerometers (MMA726x family), low-power 8-bit MCUs (S08QE family) and high-performance, connectivity-enabled ColdFire MCUs (MCF51JM family) are the key elements used to build the SGS system. Technical support is also available, and Freescale designers regularly consult with customers and medical doctors to develop more new products that can improve the quality of life.

## References

- [1] "Photic- and Pattern-Induced Seizures: Expert Consensus of the Epilepsy Foundation of America Working Group," Graham Harding, Arnold J. Wilkins, Giuseppe Erba, Gregory L. Barkley and Robert S. Fisher, *Epilepsia*, 46(9): 1423-1425, 2005
- [2] "Massively Multiplayer Online Role-Playing Game-Induced Seizures: A Neglected Health Problem in Internet Addiction," Yao-Chung Chuang, *CyberPsychology & Behavior*, August 1, 2006, 9(4): 451-456
- [3] "Game-Related Seizures Presenting with Two Types of Clinical Features," Yao-Chung Chuang, Wen-Neng Chang, Tsu-Kung Lin, Cheng-Hsien Lu, Shang-Der Chen, Chi-Ren Huang, *Seizure* (2006) 15, 98-105
- [4] "Mechanisms of Video-Game Epilepsy," F. Fylan, G. F. A. Harding, A. S. Edson and R. M. Webb, *Epilepsia*, 40(Suppl. 4): 28-30, 1999
- [5] "Video-Game Epilepsy: A European Study," D. G. Kasteleijn-Nolst Trenité, A. Martins da Silva, T. S. Ricci, C. D. Binnie, G. Rubboli, C. A. Tassinari and J. P. Segers, *Epilepsia*, 40(Suppl. 4): 70-74, 1999

Ju Yingyi is a ColdFire application engineer with expertise in SMAC, FAT/FAT32 and microWindows (GUI). Shen Li is also a ColdFire application engineer. He has a master's degree in communication and information systems and has been with Freescale for almost five years. Gabriela López-Armas, M.D., is a postgraduate resident in biomedical sciences at the Laboratory of Neuroscience of the Centro de Investigación Biomédica de Occidente (Western Biomedical Research Centre) belonging to the Social Security Mexican Institute. Dr. Rosales is a pediatric surgeon and holds a Ph.D. in neurodegenerative disorders. His research has been recognized in the Alzheimer Association for entrepreneur activities in this field.



Dr. José Fernández Villaseñor and Jesus Gaytan

# Telemonitoring Solutions

## A new approach to better patient health

### Aging population and chronic degenerative diseases

The aging of the world's population is a fact in our society. Baby boomers are now becoming our senior citizens, fueling the growth of the aged population. To accommodate this dramatic population shift, drastic changes in our health systems are necessary. Today, these changes include new therapies and early diagnostic tools with advanced sensor and microcontroller (MCU) technologies that are accessible by the general population.

Non-communicable diseases accounted for almost 50 percent of the global disease burden, according to the World Health Organization (WHO). Among these, the highest incidences are for chronic degenerative diseases, such as cardiovascular disease, in which hypertension plays a large part (600 million people worldwide), and metabolic diseases like diabetes (90 million people).

A significant issue with chronic degenerative and metabolic diseases is that a patient needs to control the homeostasis or physiological balance for long periods of time, which means developing new habits in their daily lives, like taking blood pressure or glucose measurements. These can be annoying and disruptive tasks that can be forgotten or even purposefully avoided, providing no help to the physician on how the treatment is improving the patient's health.

Chronic diseases such as diabetes and hypertension are becoming worldwide public health problems due to the lack of symptom control and the knowledge to recognize the body's way of letting us know that something is not going well. The prevention and early treatment of the sudden (acute) complications of these kinds of pathologies is vital for reducing any deaths they cause.

In addition, medical costs can become an issue, because long-term pathologies can become a financial burden for the patient. For this reason, it's very important for insurance companies to be aware of how technology and new medical devices can prevent acute complications, since they count for a large number of reimbursement applications.

Enabling physicians or health care providers to access patient monitoring data at any time is one way that doctors can improve patient treatment. For instance, if something is not normal, a monitoring system can start sending data to whoever would make the appropriate diagnostic decisions to avoid a complication. Also, since some problems can be silent complications, a systematic monitoring of vital signs and other readings can prevent further complications.

### Telehealth monitoring systems can prevent the acute complications of chronic degenerative diseases

Telehealth solutions directly address the chronic degenerative diseases problem. Intelligent systems that acquire data from endpoint devices, such as blood glucose meters (glucometers), heart rate monitors, blood pressure monitors, digital scales, etc., can advise patients on the proper time for taking new measurements or medication. The telehealth system must also ensure that the data is analyzed and securely transmitted to the health care provider.

A telehealth monitoring system collects, analyzes and monitors a patient's vital signs data and uses telecommunications technology to transfer this information to a remote health provider for further analysis, which can include tracking the evolution of a chronic degenerative disease or monitoring post-operative treatment. This type of telehealth system can be customized by attaching different data acquisition peripherals, such as blood pressure meters, glucometers, pulse oximeters (for measuring oxygen saturation levels in the blood), digital scales and thermometers, among others.

One of the many advantages of this kind of system is the immediate transmission of the patient's vital signs data to a remote medical center. For this purpose, different types of networks can be used, such as wired or wireless Ethernet through a secure virtual private network (VPN) connection or a general packet radio service (GPRS) network for patients living in rural areas without access to a broadband network.

## General Telehealth Application Block Diagram

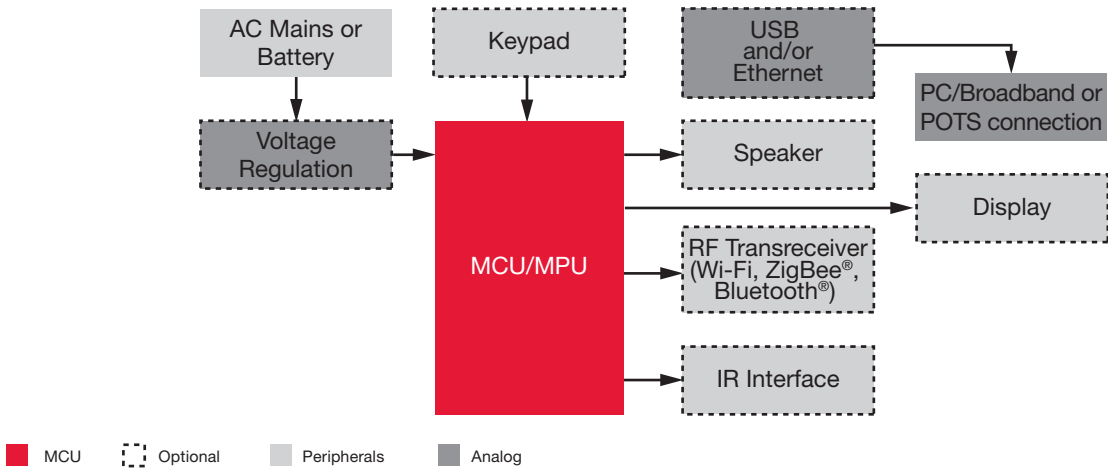
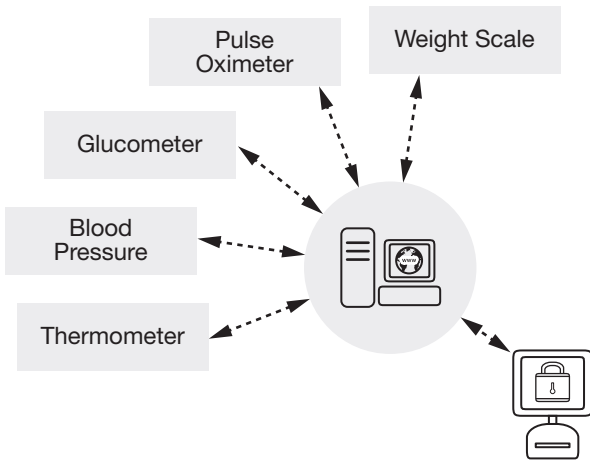

Figure 1

## Telehealth Network



The telehealth monitoring systems are primarily designed for a home-medical environment where a rich graphical user interface (GUI) can help guide patients through the process of measuring vital signs. This article provides an overview of how a telehealth monitoring system can be implemented using Freescale's Solution Enablement Layer to provide portability across Freescale's 32-bit processor portfolio.

It is critical that telehealth devices should be personalized to address a particular disease or condition and cater to the patient's specific needs. This is a challenge for both system designers and OEMs. Scalability, low power consumption and a rich peripheral set are key design considerations for telehealth system design engineers. This article discusses the medical risks of hypertension and diabetes and describes telehealth solutions for patients suffering from these conditions.

Figure 2

## Portable Wireless Telehealth System

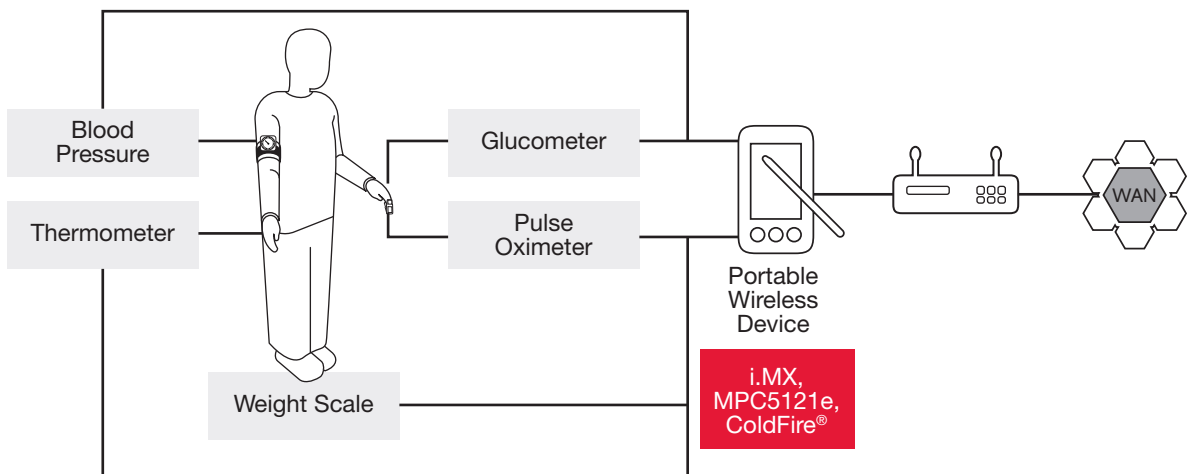

Figure 3

## Hypertension and diabetes: medical standards for prevention, detection and evaluation

The Seventh Report of the Joint National Committee on Prevention, Detection, Evaluation, and Treatment of High Blood Pressure (JNC7) has published some important guidelines regarding hypertension prevention and management. The following are key points taken from the report:

- In persons older than 50 years, systolic blood pressure greater than 140 mmHg is a much more important cardiovascular disease (CVD) risk factor than diastolic blood pressure.
- The risk of CVD, beginning at 115/75 mmHg, doubles with each increment of 20/10 mmHg. Individuals who are normotensive at age 55 have a 90 percent lifetime risk for developing hypertension.
- Individuals with a systolic blood pressure of 120–139 mmHg or a diastolic blood pressure of 80–89 mmHg should be considered as prehypertensive and require health-promoting lifestyle modifications to prevent CVD.
- Thiazide-type diuretics should be used in drug treatments for most patients with uncomplicated hypertension, either alone or combined with drugs from other classes. Certain high-risk conditions are compelling indications for the initial use of other antihypertensive drug classes (angiotensin converting enzyme inhibitors, angiotensin receptor blockers, beta-blockers, calcium channel blockers).
- Most patients with hypertension will require two or more antihypertensive medications to achieve goal blood pressure (<140/90 mmHg or <130/80 mmHg for patients with diabetes or chronic kidney disease).
- If the blood pressure is >20/10 mmHg above goal blood pressure, consideration should be given to initiating therapy with two agents, one of which usually should be a thiazide-type diuretic.
- The most effective therapy prescribed by the most careful clinicians will control hypertension only if patients are motivated. Motivation improves when patients have positive experiences with, and trust in, the clinician. Empathy builds trust and is a potent motivator.

## Acute complications of hypertension

The most life threatening acute complications are hypertensive urgency and emergency. Hypertensive emergency is characterized by a severe elevation in blood pressure, above 180/120 mmHg, complicated by target organ dysfunction, such as cerebrovascular events, pulmonary edema, coronary ischemia or renal failure among others. Hypertensive urgency does not include progressive target organ dysfunction.

Distinguishing between hypertensive emergency and urgency is crucial to appropriate management. Diagnosis could be done easily by telehealth devices that already have data from the patient's history, including medications the patient is taking. It helps as well to monitor other signs and symptoms that the patient could be experiencing that do not relate to the pathology, such as those in the following table.

**Signs and Symptoms of Hypertensive Crises, Urgencies and Emergencies**

| Signs and Symptoms    | Hypertensive Crises, % | Urgencies, % | Emergencies, % | P     |
|-----------------------|------------------------|--------------|----------------|-------|
| Headache              | 17.0                   | 22.0         | 3.0            | <.001 |
| Epistaxis             | 13.0                   | 17.0         | 0.0            | <.001 |
| Chest pain            | 13.0                   | 9.0          | 27.0           | <.005 |
| Dyspnea               | 12.0                   | 9.0          | 22.0           | <.02  |
| Faintness             | 10.0                   | 10.0         | 10.0           | NS    |
| Psychomotor agitation | 7.0                    | 10.0         | 0.0            | <.004 |
| Neurological deficit  | 7.0                    | 3.0          | 21.0           | <.001 |
| Vertigo               | 6.5                    | 7.0          | 3.0            | NS    |
| Paresthesia           | 6.5                    | 6.0          | 8.0            | NS    |
| Vomitus               | 2.5                    | 2.0          | 3.0            | NS    |
| Arrhythmia            | 1.0                    | 6.0          | 0.0            | <.04  |
| Other                 | 5.6                    | 2.0          | 3.0            | NS    |

Hypertensive Urgencies and Emergencies. Prevalence and Clinical Presentation. Bruno Zampaglione; Claudio Pascale; Marco Marchisio; Paolo Cavallo-Perin

**Table 1**

Hypertensive urgency is managed using oral antihypertensive drugs as an outpatient or in a same-day observational setting. Hypertensive emergency requires the patient to be taken to an intensive care unit with parenteral medication. For treating hypertensive urgency, the goal is to reduce mean arterial pressure (MAP) by no more than 25 percent in the first 24 hours with oral therapy.

$$MAP \approx DP + \frac{1}{3}(SP - DP)$$

In a hypertensive emergency, MAP should be reduced by 10 percent during the first hour and an additional 15 percent in the following two to three hours. It's clear to see that automating the data collection under these circumstances is vitally important for the physician to accurately manage this complication.

## Diabetes

In diabetics, poorly controlled glucose levels could lead to vascular complications, such as arterial microthromboses, retinopathy, nephropathy and neuropathy. These conditions are primarily caused by superoxide production, the activation of protein kinase C, serum glycosylation and the formation of glycation end products.

## Acute complications of diabetes

The most common acute diabetic complication is hypoglycemia (very low blood glucose levels), which can result when patients are concerned about high levels of glucose (hyperglycemia) and over compensate with too much insulin. Hyperglycemia is primarily responsible for chronic complications like diabetic retinopathy, nephropathy, neuropathies, infection and others.

Strict control of glucose is inadvisable in some patients, such as those with short life expectancy, hypoglycemic symptom unawareness or those who cannot communicate the symptoms, like young children. However, by using telehealth solutions with powerful closed loop systems in which glucometers and insulin pumps are merged together, these kinds of situations can be avoided.

One of the most common causes of hypoglycemia in elderly patients is an overdose of antiglycemic drugs. Sometimes they forget they have already taken their dosage and by mistake take another dose of the drugs.

## Freescale enables technologies for avoiding acute complications of chronic degenerative and metabolic diseases

### Solution Enablement Layer

The Freescale Solution Enablement Layer (SEL)<sup>[1]</sup> is an embedded software platform running with standard operating systems, such as Linux and uCLinux, to provide application framework capabilities and abstracted hardware drivers (called services). The SEL is designed to support a compile-and-deploy model of software reusability across a range of Freescale 32-bit processors.

The SEL service is the primary abstraction mechanism designed to allow the partitioning of applications into hardware-specific software components. Since services can be written for specific hardware, the application source code can have control and consistent behavior without being tied to a specific processor. Moving from one platform to another becomes as simple as partially re-implementing the service for the new hardware device. Moreover, services are RTOS-agnostic and can be shared by multiple applications. Services are designed to be reusable between applications. In fact, Freescale and third parties can provide suites of services that eliminate the redundant portions of software solutions while still getting the most from specific processor capabilities.

Application frameworks and SEL services are the primary elements of the SEL technology.

- **Application frameworks** define prevalidated application frameworks that exist for rapid prototyping and application development. Most application frameworks are suites of C++

classes designed to interact and define consistent application behavior and look and feel and often implement a rich user interface.

- **SEL services** are application partitioning mechanisms available for partitioning software components from the underlying hardware design, so that applications need only be recompiled to migrate from one platform (HW and RTOS) to another.

Conceptually, the SEL is an extension of the operating system running on the embedded processor that allows another level of application abstraction. SEL services are therefore application subcomponents that are not operating system-specific and can be shared.

### SEL services

SEL services are central components in a software solution's implementation. As applications begin to use the SEL, they can start by abstracting only a single service for a particularly complex piece of hardware-specific code while the rest of the application directly calls the operating system. Over time, more and more of the functionality can be divided into services, resulting in the application code becoming more and more abstracted from the hardware without losing any of the underlying hardware functionality. This gradual process allows users to convert to SEL over the life of one or more projects.

### SEL services properties

- SEL services—insulate the application from both OS and HW differences and are dynamically loaded at runtime
- SEL service interface—directly useable from within an application or the command line
- SEL extended services—may derive functionality based on existing SEL services

## Telehealth monitoring system services

Working down from a software solution through a hardware implementation in a telehealth monitoring system, developers want to write application code that is easy to migrate among hardware devices and RTOS platforms. The SEL allows applications to be segmented to:

- Define the GUIs independent of SEL services
  - Main control with personalized items for vital signs on patient GUI
  - Blood pressure with symptoms for acute complications GUI
  - Glucometer with symptoms for acute complications and prevention of double intake of dosage GUI
  - Pulse oximeter for chronic obstructive pulmonary disease GUI

## Medical SEL Services

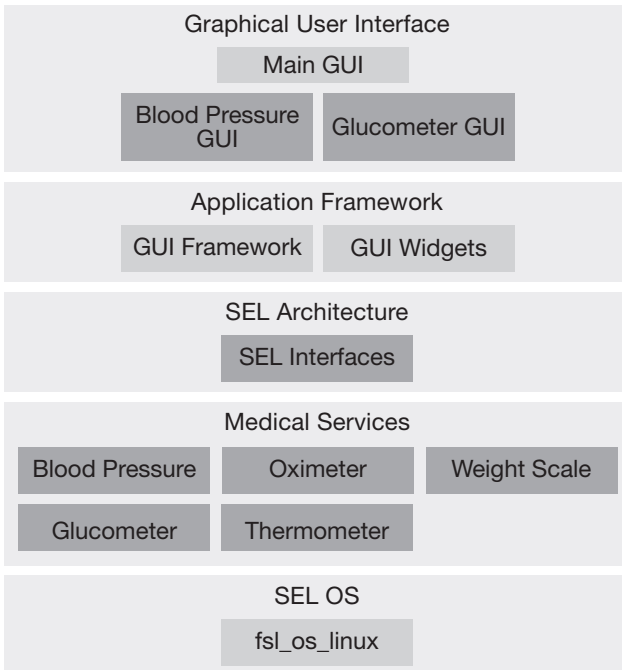

MCF52277 MCF5329 i.MX31 MPC5121e MPC8360

Figure 4

## Medical SEL Services in a MCF5329 ColdFire Processor

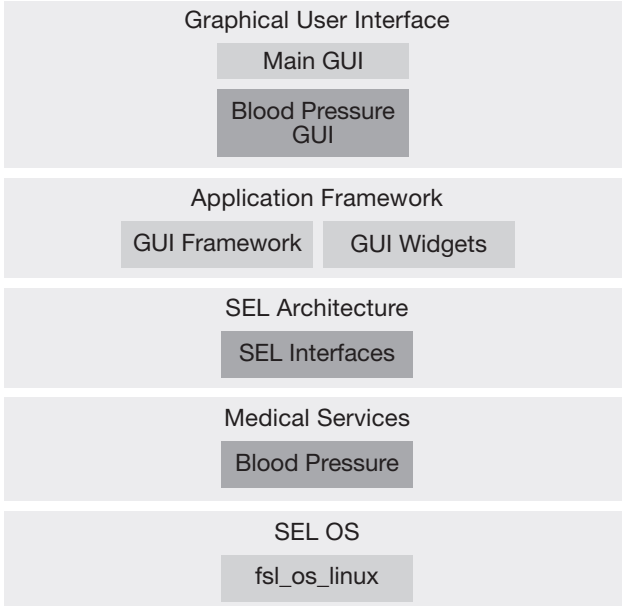

MCF5329

Figure 5

José Fernández Villaseñor is a medical doctor and electrical engineer who combines his work at Freescale Semiconductor as a medical product marketer and his work as a hospital physician. He has more than eight years of experience working on automotive, industrial and medical engineering systems and applications as well as semiconductor product development. He is currently part of Freescale's Microcontroller Solutions Group. Jesus Gaytan is the software lead for Freescale's Extensible Software Platform team in Guadalajara and has been with the company since 2006. He holds a bachelor's degree in computer science.

- Define application services that are HW- or RTOS-independent, such that re-implementing part of the service allows the user to easily migrate through the 32-bit processor portfolio
  - Blood pressure service (systolic, diastolic and mean arterial pressure)
  - Glucometer service
  - Pulse oximeter service
  - Thermometer service (infectious disease complications)
  - Digital weight scale service (for monitoring water retained in patients with congestive heart failure)

Following that software partition, a telemonitoring system application could have multiple services running in a high-end processor, such as Freescale's i.MX, MPC51xx or ColdFire® processor, or the application might be tailored to implement a couple of services in a low-end processor. Figure 4 illustrates a complete telemonitoring system using the medical services suite.

## Conclusion

Modern society faces public health issues due to the rapidly aging population and their pathologies' demographics. This means providing systems that can remotely monitor vital signs and drug intakes to help avoid acute complications that result in higher costs for patients admitted to a hospital ER facility.

To address these issues, Freescale offers medical equipment designers and OEMs hardware tools and a new software platform (SEL) that enables concurrent software and hardware development and allows hardware designers to deliver their solutions to market faster.

Reusing SEL services and spanning their usage across the 32-bit processor portfolio enables accurate and rapid development of telehealth applications that create a virtual bridge between doctor and patient.

## References

- [1] Solution Enablement Layer Architecture V1.0 Benedek Aaron, Hemstreet Greg



Raman Sharma

# Low-Energy Wireless

## Just what the doctor ordered

### Introduction

The medical market, while on the frontier of human sciences, has always been conservative and cautious when it comes to analyzing the market's technology adoption rate. While the rest of the industrial and consumer markets were immersed in the potential of wireless connectivity, networking and the Internet, the medical market continued to build devices with tried and tested technology. However, we are now witnessing a technology revolution in the medical market. This is in part due to a perfect storm of events: an aging population, increasingly costly health care and rapidly developing technology trends.

A global aging population combined with rising health care costs is straining the world's health care infrastructure. For instance, baby boomers are entering an age bracket where they will be affected by chronic diseases. As the burden of illness increases, the health care system will not have enough professionals to care for the ill.<sup>[1]</sup> We are at a point where yesterday's technology, adapted to today's medical market, can solve critical unmet needs in medicine, such as improved health care coverage and quality, and lower health care costs. One such technology is wireless.

Wireless technology can be used in a variety of medical applications—in the hospital, in the home, on the body and, lastly, implanted within the body. Although the focus of this article is low-energy wireless in the home and on the body, it is worthwhile to briefly mention the wireless standard for implantable devices—Medical Implant Communication Service (MICS). MICS was established by the US Federal Communications Commission (FCC) in 1999 in the 402 MHz to 405 MHz frequency band (the same band as for weather balloons). While MICS is not the primary allocation of this frequency band, it is used in the US, EU, New Zealand, Japan and Canada to provide a communication medium between an implanted “can,” such as a pacemaker, and an external programmer. The range is typically two meters with a power limitation of 25 mW.

### Wireless telehealth overview

Telehealth is one of the primary applications for low-energy wireless connectivity in medicine. Telehealth is a broad term used to describe telemedicine, telemonitoring and telecare. Wireless technology is making a huge impact in telemonitoring by enabling remote patient monitoring for the healthy (preventative medicine) and for those that require management of chronic diseases. Wireless technology will allow doctors to improve quality of care by providing a new method to collect more relevant data, more frequently and at a lower cost.

We've seen this story unfold before, however, where a game changing technology comes along, only to be derailed by the lack of interoperability. Fortunately, because the medical market has been slow to adopt new technology, this problem has already been solved and similar applications have proven successful in other markets. The answer for the medical market is standards. Standards will allow medical devices to talk to each other and deliver the promise of telehealth. There are two associations driving standards for low-energy wireless technology in the health care industry: Continua Health Alliance and IEEE® 802.15.6 wireless body area network (WBAN).

### Standardizing wireless telehealth

Continua's mission is to establish a standard for medical devices and systems within the personal health care (which includes telehealth) and fitness monitoring application space. One of Continua's key criteria is to choose a technology or technologies that are globally applicable. Therefore, technologies that operate in the 868 MHz and/or 915 MHz bands are automatically locked out of the greater world market, including Japan, Korea and China.

Freescale, with its broad portfolio of microcontrollers, sensors and analog devices, can enable Continua's mission by providing solutions for satellite devices that collect the data and the infrastructure devices that analyze and manage the data. No other company of similar size and pedigree can approach this space in such a one-stop-shop way.

## Wireless Options for Medical Applications

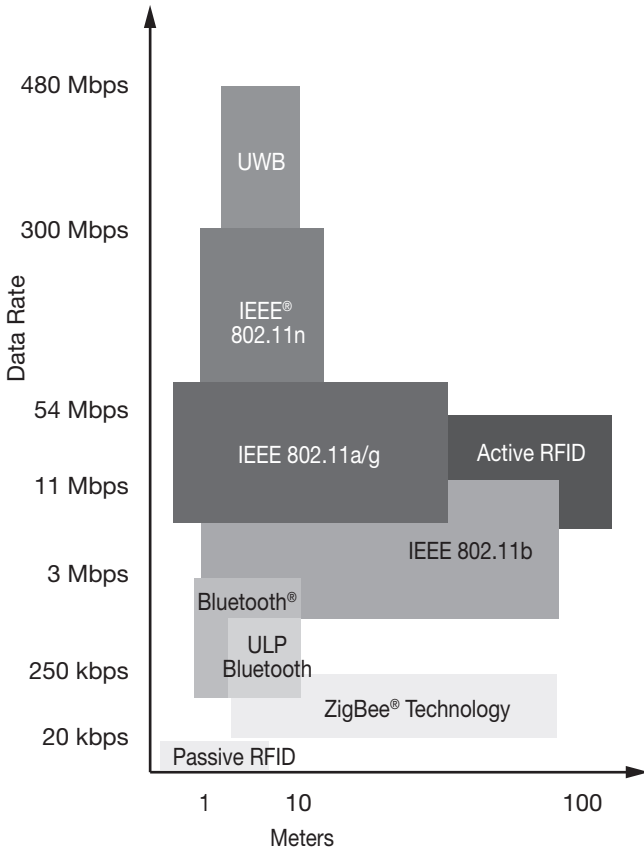

Figure 1

## Telehealth System Concept

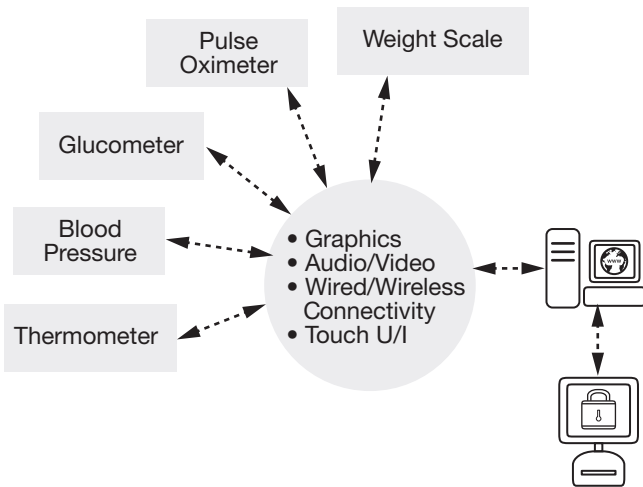

Figure 2

Continua recently published version 1 (V1) of its guidelines for wireless connectivity for portable medical/telehealth applications. In this initial version, Continua selected Bluetooth® technology as the wireless standard (USB was selected for wired connectivity) and we will soon see interoperable medical devices from leading device manufacturers that will be certified by Continua.

Bluetooth wireless technology certainly meets the needs of the medical market from a risk mitigation point of view. According to market analysts, over one billion Bluetooth chipsets were shipped in each of the last two years. With these numbers, there is no doubt that Bluetooth technology is tried and tested. However, many argue that Bluetooth technology is not ideal for the intended medical use cases where low data rate, low power and short range are key requirements. As a result, Bluetooth Low Energy (BTLE) is being promoted for the second version (V2) of the Continua guidelines.

### Bluetooth® Wireless Technology and BTLE Technical Merits

|                      | Bluetooth | BTLE   |
|----------------------|-----------|--|
| Frequency Band       | 2.4 GHz   | 2.4 GHz  |
| Data Rate            | 1-3 Mbps  | 1 Mbps   |
| Range (meters)       | 5-10      | 5-10   |
| Max Power            | +20 dbm   | +10 dbm  |
| Modulation           | GFSK, PSK | GFSK   |
| Low-Power Capability | Not ideal | Sleep modes to conserve power. Designed for battery operation. |

Table 1

BTLE is specified for short-range, low-energy applications where only short bursts of data are required (i.e. non-streaming data). Low latency and available sleep modes allow BTLE to boast low power consumption characteristics. Furthermore, based on the simple BTLE framework, processor memory and performance requirements are low. Although BTLE is now a part of the Bluetooth Special Interest Group (SIG), there are significant differences between the two standards.

The key difference between Bluetooth wireless technology and BTLE is that BTLE is designed for low-power, battery-powered applications. This will effectively serve the portable medical market since 18 months of battery life for portable medical monitors is a requirement from various manufacturers. However, it is important to note that Bluetooth technology and BTLE are not inherently interoperable. The Bluetooth device must be new enough to understand BTLE. For many devices already in the field, that may be difficult. Therefore, interoperability may really only begin with the next generation of Bluetooth devices beyond the ones available today.

## Wireless Protocols Contending for Continua's V2 Guidelines

| Wireless Standard | Data Rate  | Range   | Nodes      | Battery Life | Frequency Band                |
|-------------------|------------|---------|------------|--------------|-------------------------------|
| ANT               | 1000 Kbps  |         | 65,000 + 1 | ~4 years     | 2.4 GHz                       |
| Sensium           | 50 Kbps    | 3m      | 8 + 1      | > 1 year     | 862–870 MHz<br>902–928 MHz    |
| Z-Wave            | 9,600 Kbps | 30–100m | 232        | > 1 year     | 900 MHz                       |
| BodyLAN           | 1000 Kbps  |         |            |              | 2.4 GHz                       |
| BTLE              | 1000 Kbps  | 5–10m   | 7 + 1      | 1 year       | 2.4 GHz                       |
| ZigBee®           | 250 Kbps   | 1–100m  | 65,524     | > 3 years    | 868 MHz<br>915 MHz<br>2.5 GHz |

Table 2

BTLE is the leading contender for Continua's V2 guidelines, however, ZigBee® technology is also a strong and viable candidate. Besides BTLE, there are five other wireless protocols that are in contention for V2 guidelines:

- **ANT:** Proprietary 2.4 GHz technology developed by Dynastream. ANT is currently used in some health and fitness products, using a version of the Nordic nRF24 transmitter. Total volume to date is a few million units, and an alliance has been created to promote an ecosystem.
- **Sensium:** Proprietary 868/915 MHz technology developed by Toumaz.
- **Z-Wave:** Proprietary technology developed by Zensys. Total volume to date is a few million units and an alliance exists to promote an ecosystem.
- **BodyLAN:** Proprietary 2.4 GHz technology developed by FitSense. This is part of a larger effort that includes fitness equipment and fitness centers. Total volume is unknown, but appears to be less than a million units.
- **ZigBee:** The only technology based on an international standards body (IEEE). The ZigBee Alliance, an open organization, has the personal, home and hospital care (PHHC) profile that caters to the Continua-defined use cases. IEEE 802.15.4 total volume to date is around 25 million units and growing rapidly.

While Continua would like to accept only one additional wireless technology in its V2 guidelines, it is not mandatory that only one is selected. Companies such as Philips, Motorola and Freescale are working together to promote ZigBee as one of the standards approved by Continua.

IEEE is also focusing on establishing a wireless standard for medical applications. IEEE 802.15.6, or WBAN, is strictly focused on wirelessly connecting sensors worn on the body. In comparison, Continua is creating use cases for both WBAN and personal area networks (PAN). PAN use cases include wirelessly connecting portable medical monitors to telemonitoring gateways (see Figure 2).

A task group for IEEE 802.15.6 has recently been formed to develop the WBAN standard encompassing a physical layer (PHY) and media access control (MAC) layers. Although this group is in its infancy, the high-level technical requirements include low power consumption, security, multi-node networking, interference protection and coexistence.

Wireless applications in the medical market are on the cusp of a breakthrough. Imagine a system that uses a sensor embedded in your clothing to monitor your heart rate, then transmits the data to a telemonitoring gateway and alerts your physician, all wirelessly, without intervention. The only way for this to become a reality is to establish standards so various sensors and portable medical monitors can speak to each other. This is exactly what Continua and IEEE are doing with the support of technology drivers like Freescale. The vision is set, standards are being defined, and a technology revolution for the medical market is underway.

## References

- [1] "Tele-What?: It's Time to Re-Think the Industry's Terms," Wuorenma, Jan K, TeleHealth World, Vol. 1, p. 7, Fall 2008

Raman Sharma has 10 years of high-tech experience. He has worked in several functions, ranging from ASIC design engineer, applications engineer, sales and marketing and management. Raman has a masters in electrical and computer engineering from Carnegie Mellon University and an MBA from the Kellogg School of Management. At Carnegie Mellon, Raman focused on wearable computing and biomedical engineering. At Freescale, Raman is the Global Medical Segment manager responsible for business strategy, marketing, new product roadmaps and revenue growth.

Alfredo Soto with Dr. Juan Carrillo Jiménez

# Automatic Ventilation Control

## Cost-effective alternative to manual ventilation

### Introduction

This article describes the design of a portable automatic ventilation control system that also processes arterial oxygen saturation (SpO<sub>2</sub>) data from a pulse oximeter. The system, built around Freescale's 8-bit MC9S08QG4 microcontroller (MCU), is designed to be a portable, automatic replacement for manual pulse oxygen and ventilation monitoring and control, requiring less human interaction during surgery. It can be particularly useful during surgery on infants.

### Overview

All tissues are fed by oxygen transported through the blood vessels, which is needed to grow the tissue and repair damage. Normally, the body regulates a constant oxygen concentration in extra-cellular fluids, relying primarily on the chemical characteristics of the hemoglobin in red blood cells.

For most surgeries, however, the doctors must introduce a certain amount of anesthesia, which also acts as a muscle inhibitor. This automatically reduces the patient's breathing, and when combined with the blood loss during surgery, can result in hypoxia, or lack of sufficient oxygen in the patient's body. That's why the doctors must use an anesthetic ventilator and a meter to measure oxygen saturation in the blood (pulse oximeter) to regulate the anesthesia-oxygen mixture applied during surgery.

With mechanical ventilation, an external device is connected directly to the patient and artificially exchanges respiratory gases. Mechanical ventilation is designed to maintain an adequate exchange of gases, even through diminished breathing rates and reduced myocardial use. However, it could also be used to provide adequate lung expansion with reduced respiratory effort, the correct combination of anesthetic sedation and muscle-relaxing related drugs and to stabilize the thoracic wall.

Ventilators can be divided into five classifications, depending on how the inhaling process is terminated:

- Pressure-cycled ventilator: Inspiration of gas is stopped when a designated pressure is achieved.
- Volume-cycled ventilator: Inspiration ends when the desired volume of gas has been introduced.

- Time-cycled ventilator: Inspiration and expiration are programmed the same as the gas flux.
- Flux-cycled ventilator: Inspiration ends when the inspiratory flux is below a pre-determined level.
- Mixed ventilator: The most commonly used; combines the attributes of the other classifications.

Physicians can set blood oxygen tolerance limits, and when oxygen saturation gets too low the ventilator can switch from manual to automatic mode to help the patient reach adequate oxygen saturation. When normal levels are achieved, the system exits automatic mode.

### How to select the adequate ventilator for pediatric patients

Newborns have an elevated metabolic rate that leads to increased oxygen consumption (5–8 ml/kg). Premature babies that weigh less than 1600 grams and have a gestational age below 37 weeks are at higher risk of retinopathy of prematurity, which can be caused by oxygen toxicity and lung dysplasia, resulting from the high pressures of oxygen delivery. It is critical that the automatic ventilation systems are used in these cases to ensure that the infants do not receive 100 percent oxygen concentrations.

In newborns, the pressure-limited continuous-flux devices and time-cycled ventilators allow adequate spontaneous respiration without restriction. In school children (6 to 11 years) and children above the age of 12, the pulsed-flux ventilators are used to control volume as well as pressure. New generations of volumetric ventilators allow flux volumes up to 20 ml, and they now incorporate sensors to automatically cycle the device to allow doctors to use them for two to three kilogram babies.

### Circuits

A circuit is the interface between the mechanical ventilator and the patient. There are three types: neonatal (11 mm diameter), pediatric (15 mm) and adult (22 mm). Some circuits have heating wires with a servo-controlled humidifier temperature system. These are quite expensive, but they allow optimum humidity and temperature for pediatric patients.

They are lightweight, flexible and occlusion-resistant with safe connections and minimum flux resistance, and they are available in standard sizes (15–22 mm).

## How the system works

The automatic ventilation system is designed to offer safe and controlled ventilation for babies along with blood oxygen level feedback. The main features include:

- The ability to receive and process parameters for measuring arterial oxygen saturation as sent by a pulse oximeter
- Portability, for use in remote locations
- Communication between the oximeter and the system's MCU via serial interface (SCI)
- Stepper motors that provide precise instrument control according to set parameters to deliver exact ventilation frequency and pressure

Thanks to the MCU, an automatic ventilation control system can be developed where important data can be processed and stored to ensure proper ventilation for patients of a specific size and weight. Programs can be written that address only those physical parameters in question, without altering any other aspect of the system. Figure 1 illustrates the automatic ventilation control implementation.

### Automatic Ventilation Control System Block Diagram

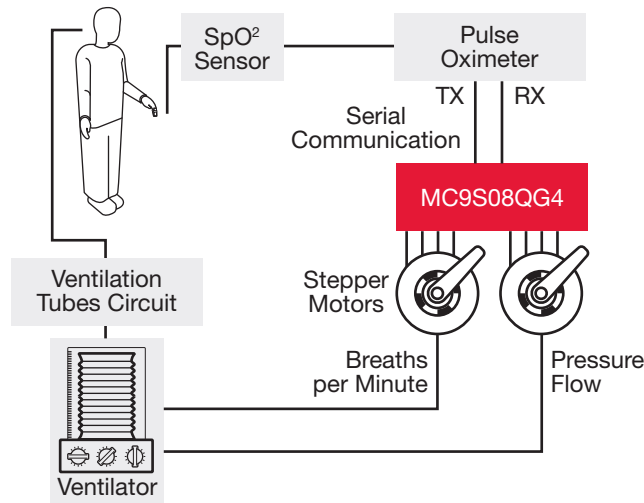

Figure 1

## Choosing the right MCU

Multiple alternatives exist when selecting an MCU for this application system. The Freescale MC9S08QG4 (S08QG) device offers an excellent combination of the features needed at a very competitive cost. It extends the advantages of Freescale's S08 core to low-pin-count, small-package options. S08QG devices are low voltage with on-chip in-circuit flash memory programmable down to 1.8V. They include the standard features of all S08 MCUs, including wait mode and multiple stop

modes plus strong analog capabilities, a complete set of serial modules, a temperature sensor and robust memory options.

### MC9S08QG8/4 Features

|                     |  |
|---------------------|--|
| Core                | HCS08  |
| Flash               | 8K/4K  |
| RAM (byte)          | 512/256  |
| Bus Frequency       | 10 MHz   |
| ADC                 | Up to 8 channels (10-bits)                       |
| Analog Comparater   | Yes  |
| Keyboard Interrupt  | Up to 8-pins                                     |
| Timers (up to)      | One 16-bit timer (2 channels)<br>One 8-bit timer |
| SCI                 | 1  |
| SPI                 | 1  |
| I <sup>2</sup> C    | 1  |
| Operational Voltage | 1.8–3.6V   |
| Package             | 8 DIP/SOIC/QFN, 16-pi DIP/TSSOP/QFN              |

Figure 2

## Functional description of the system

Pulse oximetry is a non-invasive technique that uses light waves to measure the oxygen saturation of a patient's blood. This procedure employs an instrument called a pulse oximeter, a portable, low-cost device that includes an SpO<sup>2</sup> sensor and a DB-9 connector compatible with the meter. The SpO<sup>2</sup> Y sensor has two light-emitting diodes (LEDs) on one side of the sensor and a light detector on the other side. The sensor is normally attached to the fingertip so the light can pass completely through the tissue to the light detector.

The light from the LEDs is transmitted in two wavelengths, 660 nm (red) and 915 nm (infrared), which correspond to the oxygenated hemoglobin and total hemoglobin, respectively. The detector captures the light emitted by LEDs, and the pulse oximeter processes the differing absorption rates between the red and infrared wavelengths. The MCU in the meter can then isolate the arterial pulsation readings and calculate the oxygen saturation.

The SpO<sup>2</sup> reading from the pulse oximeter can be transmitted to the automatic ventilation system through the serial interface (SCI) connected to the S08QG. The system will use the standard serial protocol as this is defined within the specifications of a commercial oximeter. The data from the pulse oximeter is transmitted continuously through the SCI interface to the ventilation system.

The data is processed by the S08QG and translated into motor steps to control the movement of the oxygen ventilator.



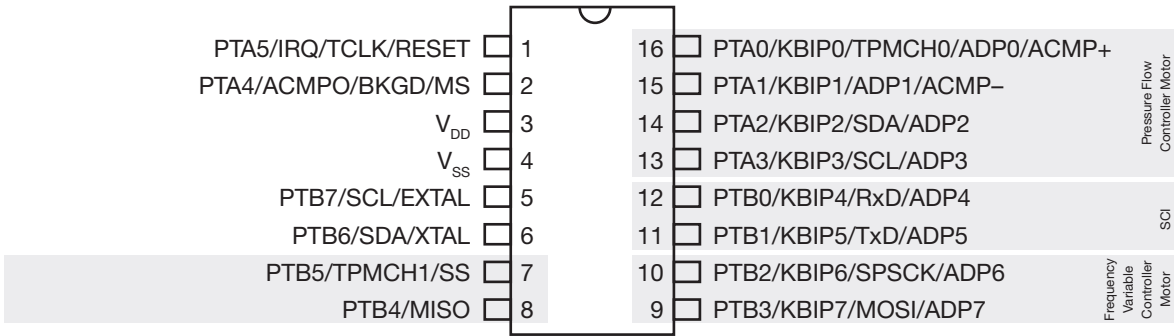

Figure 3

The control software routines for different types of stepper motors are based on variable frequency or pressure flow control:

- Variable frequency takes information from the clock pulses to control the number of steps desired.
- Pressure flow control means the motor can perform comprehensive steps, steps with great torque (double step), changes of direction and no changing position steps (inhibited steps).

Figure 3 shows a simple way to implement stepper motor control through the S08QG.

A significant characteristic of the stepper motor used to implement this application is its maximum current consumption of 20 mA. The torque provided by the motor is small, with maximum static torque at 4 mNm and maximum dynamic torque at 1.3 mNm, but it is strong enough to move standard gauges. The S08QG MCU can drive up to 25 mA, so it is well suited for this application. The motor is directly connected to the MCU using port A and port B, and based on the previous conditions, the electronic circuitry is minimal (see Figure 1). The system requires VCC, GND and the output motor controller signal. No additional external electronics are required.

The oxygen ventilator has three simple control knobs, which control the inhalation flow and breaths per minute. One knob controls proper ventilation according to the patient's size and weight. The second knob controls the desired breaths per minute, and the third manages the oxygen flow pressure. In this particular system design, the second and third knobs are automatically controlled by the stepper motors.

Software routines calculate the movement of the stepper motors according to oxygen saturation percentages sent by the pulse oximeter through the SCI interface. The oxygen saturation numbers also provide information necessary for doctors to perform a series of comparisons to determine different ranges of security, as illustrated in Table 1.

### Oxygenation Security Ranges

| Range (%) SpO <sub>2</sub> | Motor Movement        |                       | Diagnostic        |
|----------------------------|-----------------------|-----------------------|-------------------|
|                            | Pressure Flow         | Frequency             |                   |
| 93–98 %                    | Disable Step          | Disable Step          | Good Oxygenation  |
| 80–92 %                    | Disable Step          | Movement to the right | Low Oxygenation   |
| <80%                       | Movement to the right | Movement to the right | HIPO Oxygenation  |
| >98%                       | Movement to the left  | Movement to the left  | HIPER Oxygenation |

Table 1

Frequency specifies the number of motor steps per second, which determines how fast the motor rotates. The motors' physical limitations determine their operation frequencies. Some engines operate between 10 Hz and 500 Hz for very specific applications while others can operate in the kHz range. For this system, the maximum frequency is 100 Hz, but it is set at 50 Hz for optimal use by a physician during surgery.

## Conclusion

The automatic ventilation control system is a cost-effective alternative to manual ventilation control that provides reliable ventilation for infants and other patients in surgery with minimal human intervention. The concept is simple: the pulse oximeter feeds oxygen saturation percentages through an SCI interface, and the system does all the rest. It allows physicians to concentrate on patient care, and it can be used for general surgery, pediatric and neonatal care or even be adapted to veterinary clinics.

## References

- [1] AN3602: Driving a Stepper Motor Based on the MC9S08QD4 and Other 8-bit Families; Freescale Semiconductor, Rev 0, 4/2008

Alfredo Soto is a systems and applications engineer in the Technical Information Center at Freescale Semiconductor. He has a degree in electronic engineering with a specialty in control and instrumentation from Technologic of Sonora Mexico, and a master of science in electrical engineering with a specialty in bioelectronics from CINVESTAV I.PN Mexico. Dr. Carrillo holds an anesthesiology and palliative medicine degree. He has been an attendant for eight years in the Pediatric Hospital of high-risk surgery and also attends terminally ill patients as a palliative medicine specialist.

Kurt Seifert

# Health Social Networks

## Using low-cost RF devices

The total budget for health care in the United States rose to 2.26 trillion dollars in 2007, which translates to \$7,439 per inhabitant, and it has been predicted that this trend will continue to rise. Even at this cost, the United States has only the 45th highest life expectancy worldwide, according to the CIA World Fact Book (2007 estimates). As the cost of health care continues to rise, the government struggles to find new, more efficient ways to treat and prevent diseases. A proposed solution described in this article relies on significant use of low-cost, low-power RF devices.

### Introduction

According to the World Health Organization, environment is responsible for as much as 24 percent of the total cases of preventable diseases. This means that thousands of people around the world die prematurely because of unhealthy environmental conditions, such as air and water pollution. According to the US Department of Health and Human Services (HHS), personal actions, such as smoking and lack of exercise, along with poor food quality can also lead to unhealthy conditions. Millions of dollars are spent each year treating illnesses that are direct results of these risk factors. By monitoring the risk factors on a regular basis, the government would be able to prevent some diseases and treat others before they developed into more serious and expensive medical conditions.

HHS also states that some of the most common human health risk factors are related to how often people eat in restaurants<sup>[1][2]</sup>, which also can expose them to higher levels of cigarette smoke. Meals eaten outside of the home tend to contain more fat and calories and are served in larger portions. These excesses can lead to serious conditions, such as obesity and type 2 diabetes, which, in turn, can lead to heart disease. In the U.S. alone, a person dies of heart disease every 34 seconds<sup>[3]</sup>. As of yet there is no completely accurate and affordable way to monitor these different risk factors and the effects they have on the human body.

Cigarette smoke is known to contribute to serious health conditions, including heart disease, respiratory disease and several types of cancer, but there are many other air contaminants that can have adverse effects on human health. People are often unknowingly exposed to these pollutants and over time the toxins from the pollutants can accumulate within the human body.

If all of these risk factors could be monitored and the data compiled, many of the illnesses associated with them could be prevented or even eliminated. One of the main problems in implementing a solution lies in the complexity of monitoring all of these risk factors in the context of a single individual and processing the information in an efficient way. If this could be done, possibly life-threatening diseases could be identified before they reached a critical stage, and preventative measures could be taken to avoid costly health care treatments.

The main risk factors to human health are well-known, but the programs currently in place to gather information about these threats are very expensive and are not adequately accessible to the population. Governments spend large amounts of money each year on health care in an effort to research, treat and prevent diseases caused by these risk factors, but because the risk factors are not effectively monitored, improvements are slow to come. Overall health care could be improved if humans and the risk factors they encounter on a day-to-day basis could be accurately monitored at a low cost.

### Wireless sensing and monitoring solution

By monitoring the number of times that a person eats at a restaurant and the amount of exercise performed, and by using exhaust gas sensors and air contaminants sensors to detect air pollution, it's possible to predict the likelihood of individuals developing certain diseases. Preventative treatments can be administered before these illnesses develop into more serious and more expensive infirmities.

## MC13224V Platform-in-Package Block Diagram

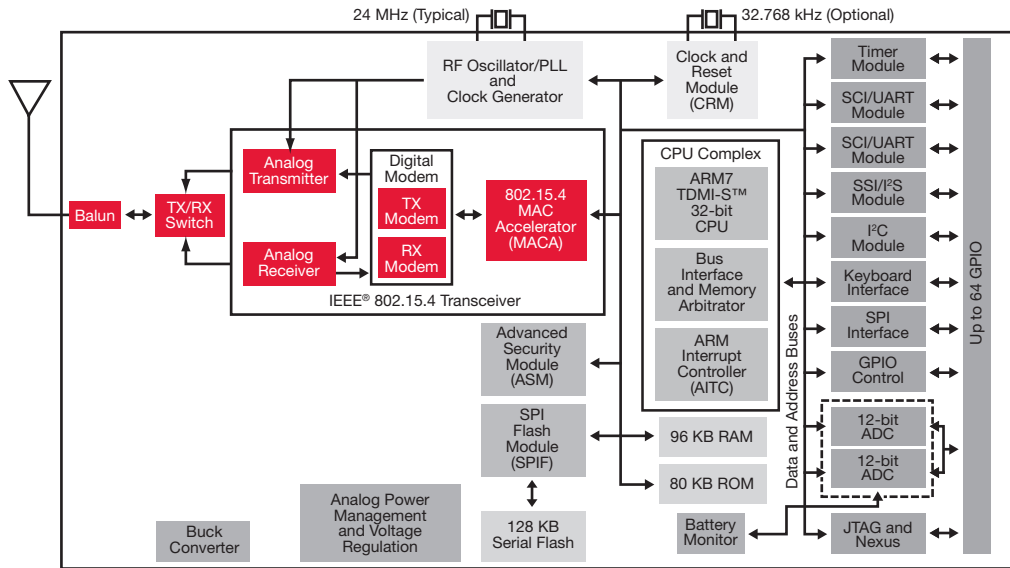

Figure 1

With the current advancements in modern low-power technology, smart wireless devices, such as the Freescale MC13224V Platform-in-Package™ (PIP) with an integrated ARM7™ based microcontroller (MCU), can be used to develop and implement cost-effective and efficient wireless monitoring solutions.

The monitoring solution is based on the fact that a person's environment can be measured or cataloged at any given moment. This is achievable if low-power wireless sensors are strategically placed to monitor the subjects as much as possible while they go about their daily routines. In order to successfully accomplish this, two types of wireless sensor nodes must be used: static and mobile. It is logical to assume that most people spend the majority of their time either at home, at work or in some cases, in transport between the two. Therefore, a static sensor node could be placed in an individual's workplace, home and mode of transportation to collect information about the quality of the environment, such as cigarette smoke, combustion gases and hazardous chemicals. A restaurant static node could be employed that would simply alert the mobile

node that the owner had eaten in a restaurant. This system won't record how many calories a person has eaten or if the food had sufficient quality, but as stated by HHS, this is enough information to give a general idea of a person's alimentary habits, which is what the application needs.

There are many ways this kind of solution could monitor an individual. For instance, it could compile the amount of time spent in the restaurant, or a signal could be sent to the individual's mobile node when the meal had been paid for. Figure 2 illustrates the hardware requirements.

The IEEE® 802.15.4 wireless communications protocol works perfectly for this implementation. This protocol supports a low-power network at moderate data rates (about 250 Kbps), and with proper implementation, can provide years of battery life from a lithium coin cell battery when used in an ultra-low-duty-cycle communications system. The protocol's IEEE 802.15.4 MAC layer by itself isn't enough, but a networking layer such as the ZigBee® wireless can provide all the necessary networking services. The proposed stack is shown in Figure 3.

### Hardware Diagram for Wireless Sensing and Monitoring

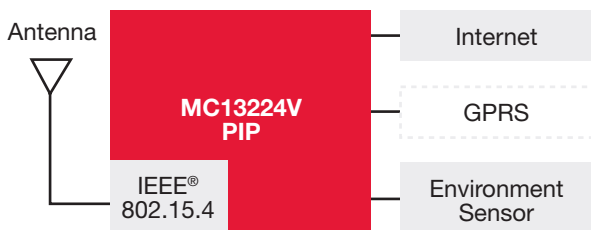

Figure 2

### Proposed Health Network Stack

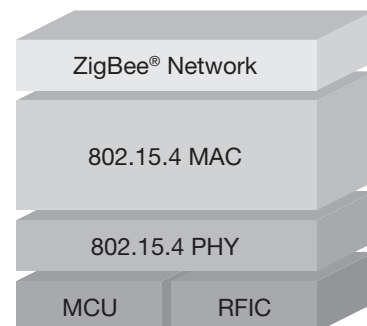

Figure 3

In the Zigbee layer there are different types of devices. Because of its constraints on power consumption, the static node would have to be a Zigbee coordinator whose main role would be to start and administer the network. The Zigbee layer of the stack would control the administration of the health data by performing different duties, such as timing, incoming data, generating the frame for this layer and processing the recently received data. Because of the application's orientation, transfers could be performed in period ranges greater than ten seconds. A general frame from a static node should contain such information as the number ID of the monitored person, information about the quality of the environment and if that person has a special message such as a health alert.

Placing sensors in highly frequented locations would not be enough to obtain a complete and accurate data set for each individual. A personal mobile sensor node would be required to collect data related to exercise. This mobile node would be equipped with an accelerometer, such as the 3-axis MMA7361L low-g acceleration sensor from Freescale, giving it the ability to measure the user's level of physical activity. Using simple algorithms, like those mentioned in the Human Fall Detection Using 3-axis Accelerometer reference manual (MMA7260QHFRM, downloadable from [www.freescale.com](http://www.freescale.com)), specific movements, such as running, walking and jumping, could be recorded. Custom features could also be added to allow the mobile node to log specific information, such as temperature or glucose levels for individuals with special requirements. The mobile node could also have the ability to recognize patterns that indicate an urgent state of medical crisis. It would be able to alert the individual of the critical state of health and he or she would be able to seek immediate medical attention.

A general frame from a mobile node should have the person's ID and statistical information, such as the risk factor measurements gathered in a single day, and special information if that person requires another kind of monitoring.

Both mobile and static nodes would have to be part of the wireless network. They could use the same data transfer software and hardware, which includes the IEEE 802.15.4 wireless protocol and an MCU. Once again, the proposed controller would be the MC13224V PIP because it features a high-performance ARM7 controller and all the IEEE 802.15.4 radio hardware. The design of this mobile node could also include a flexible sensor port capable of supporting three or more different sensors in addition to the accelerometer in order to add custom features for special patients. In this case the mobile node would be a Zigbee end device.

Since the device is mobile and battery powered, energy consumption is very important. The MCU is critical in managing energy consumption, and if a 0.1 percent TX/RX duty cycle is used, the average consumption could be as low as 40 uA.

### Possible Hardware Configuration Block Diagram

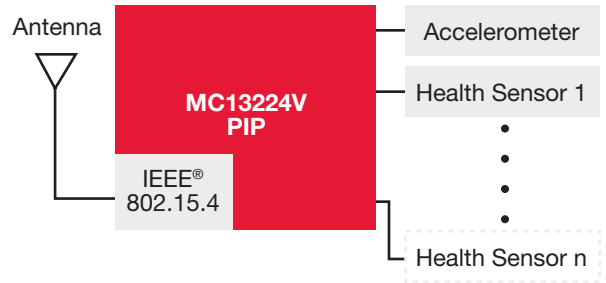

Figure 4

Using regular AA rechargeable batteries, this would mean years between charges.

Because the mobile nodes would be low power, they couldn't transmit information over long distances. It would first have to communicate with the static node via the IEEE 802.15.4 wireless protocol, and then the static node would be able to transmit the information to the diagnostic center through the Internet or cellular data network such as the general packet radio service (GPRS). If the Internet is not available, GPRS could send the information via short message service (SMS), providing additional infrastructure flexibility and making it a cost-effective solution for non-Internet data transfers.

The diagnostic center could be programmed to recognize specific patterns of risk factors and would indicate the findings to a specialist if a potential health risk was identified. The specialist would receive the data early enough to be able to analyze it and send a message to the patient in a timely manner.

The system could be flexible enough to facilitate outsourcing overnight data to another location to avoid night shifts. Because each person would have a unique ID, the data could be quickly accessed and reviewed by a specialist who would record the individual's data and determine if a potential health risk was present. If this were the case, the diagnostic center would communicate back to the static node which would then send an indicator to the individual's mobile sensor via wireless technology. Figure 5 displays the logical path of communication between the sensor nodes and the diagnostic center.

The process of generating a physical health network would be very simple (see Figure 6). A static node would first create a network by itself with no other nodes attached. Then, other static nodes could be added to create a larger wireless network. Once this was accomplished, every new mobile node would join the network by sending a beacon request. Every static node would answer the request, allowing the mobile node to detect the network. Each mobile node would decide which static node to join depending on the quality of the signal. Once the decision was made, an association request would be sent to join that

### Static Node, Mobile Node and Diagnostic Communications

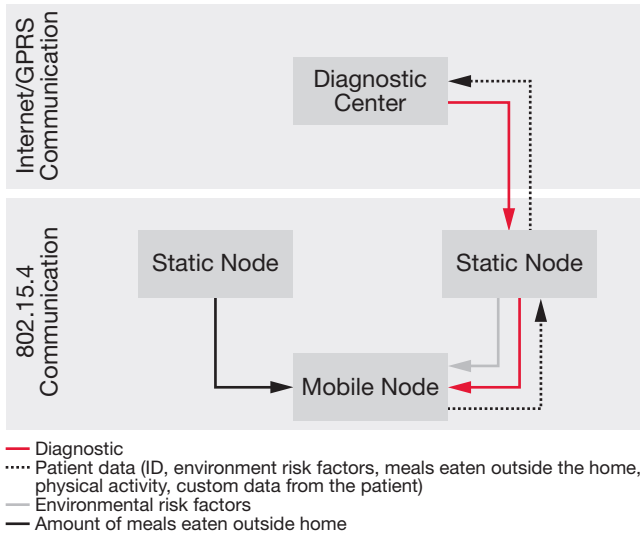

Figure 5

particular static node. Because every member of the network shares the same environmental conditions, that data would be sent as a broadcast to all members. The static node would also control sending messages to specific mobile nodes but only when the diagnostic center determines that there is a potential risk for a particular mobile node.

Theoretically, a maximum of 65,536 mobile nodes could be connected to a single static node. Because several static nodes can be expected to be placed in the network, there are no real topology issues.

Using low-cost, low-power devices to monitor the most common risk factors would provide a health care agency with a realistic and cost-effective technological platform to provide critical data for preventive and effective medical treatment, particularly for high-risk individuals. The low-power, high-performance MC13224V PIP and its implementation of the IEEE 802.15.4 protocol would be the device of choice for this application, providing a high return on investment to the total health care budget. And, thanks to the minimum number of extra components required, it would still provide huge customization capabilities to suit the different application variants.

### Static Node Network Coordination

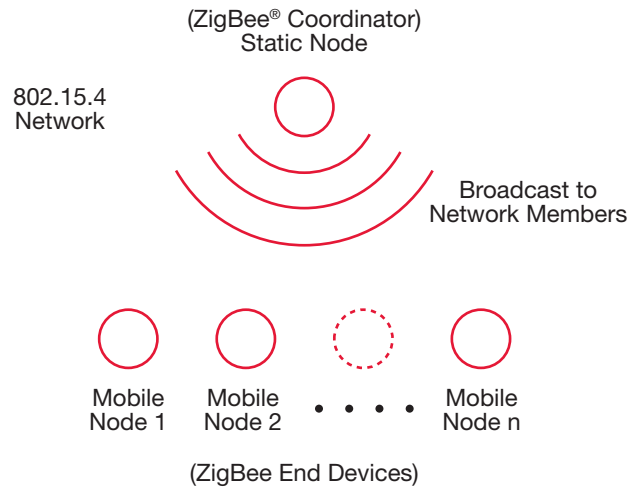

Figure 6

## Conclusion

This type of wireless sensing and monitoring system could help reduce health care expenses and increase individual life expectancy. In addition, the system itself would be a one-time investment, and the devices, once installed, would require little maintenance other than periodic recharging and sensor trimming. On the whole, the health care network could provide preemptive health checks that would reduce the time and economic resources invested in health care while improving the overall quality of life.

## References

- [1] "Away-from-Home Foods Increasingly Important to Quality of American Diet," Lin BH, Guthrie J, Frazao E., Economic Research Service, U.S. Department of Agriculture, Agriculture Information Bulletin No. 749; 1999
- [2] "Eating out in America, 1987–2000: Trends and Nutritional Correlates," Kant AK, Graubard BI., Preventive Medicine 2004; 38:243–9
- [3] American Heart Association, "Heart Disease and Stroke Statistics—2005 Update"

Kurt Seifert graduated from the Instituto Tecnológico y de Estudios Superiores de Occidente in Guadalajara México with a degree in electronics engineering with an orientation to communications. He works at Freescale in the Wireless Connectivity Operations group and his main role has been to test, design and maintain software applications.



Larry Fennigkoh and Diego Haro

# Human Factors and the Control of Medical Device-Related Error

## Introduction

Hospitals have become extremely complex, high-technology environments where the use of intrinsically dangerous equipment and procedures is routine. While the benefits associated with this technology have been tremendous, the additional complexity carries a human cost, namely, the disturbing increase in the number of patient deaths that are attributed to medical error. As concluded in the 2004 Health Grades report, Patient Safety in American Hospitals, “over 575,000 preventable deaths occurred as a direct result of the 2.5 million patient safety incidents that occurred in U.S. hospitals from 2000 through 2002.”<sup>[1]</sup> The estimated average of 191,000 deaths per year is nearly double the 98,000 annual deaths cited in the pivotal 1999 Institute of Medicine report, “To Err is Human: Building a Safer Health System.”<sup>[2]</sup>

The authors of these two major studies should be credited for waking up the government and health care community to the problem of medical error. As a result, the medical literature today includes more case studies and calls for action. Despite this growing awareness, the magnitude and seriousness of medical error remains largely obscured. The mingling of these accidental deaths with those from natural causes, combined with a gross underreporting of such accidents, makes obtaining accurate figures extremely difficult.

A major conclusion within the 1999 Institute of Medicine report, and the prevailing consensus within this community, is that most of this error is due to faulty systems and processes embedded within the health care system. It is these flawed delivery systems, not the health care worker, that tend to be directly or indirectly associated with medical errors. Systems problems require systems solutions. It is here where the interdisciplinary and systems science associated with the field of human factors offers the greatest promise.

While the full scope of medical error is much too broad to adequately address here, those errors caused or aggravated by less than optimal medical device design will be targeted. Specifically, it is through the use of established human factors principles that many common device-related errors can be

freescale.com/beyondbits

mitigated if not completely eliminated. As such, the primary purpose of this article is to encourage medical device designers and manufacturers to fully embrace many of these well-established human factors principles. These same principles have been successfully integrated throughout much of the aerospace industry, including the military, NASA and other high-risk, high-technology enterprises.<sup>[3]</sup> Human factors, as a scientific, systems-focused discipline, is poised to identify and solve many of the medical systems’ problems in general and device-related shortcomings in particular.

## Human factors as a systems science

The study of human factors is a highly interdisciplinary systems science.<sup>[4] [5]</sup> From its interdisciplinary perspective, it is heavily rooted in the principles obtained through experimental and cognitive psychology research. Such principles include, but are not limited to, how people communicate, perceive and process information, how they interact with machines and their environment (i.e., user interfaces) and how they make mistakes. The design and optimization of tools, work places and processes also borrows heavily from industrial engineering, biomechanics and anthropometry. Here, reducing work-related errors and their associated injuries and maximizing worker efficiencies are often the primary objectives. It is, however, human factors’ foundation and emphasis on systems science

### Simple Diagram of a Medical System

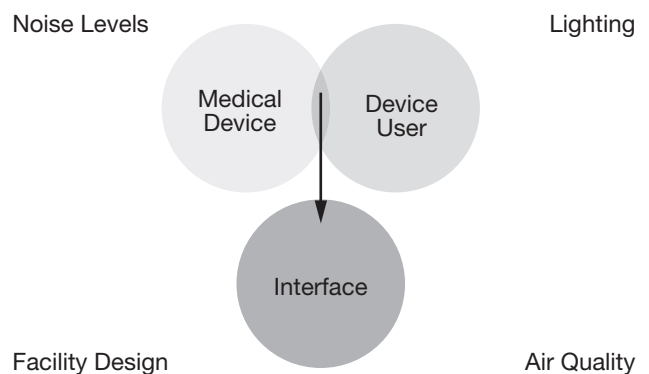

Figure 1

that offers the greatest opportunity for improved medical device design. In this context, and also as defined by Alphonse Chapanis, widely regarded as one of the fathers of ergonomics, a system is “an interacting combination, at any level of complexity, of people, materials, tools, machines, software, facilities and procedures designed to work together for some common purpose.”<sup>[5]</sup> For both the medical device designer and its clinical user, the essence of such a system is illustrated in Figure 1.

While most designers are understandably focused on developing device functionality, its ultimate performance, safety and effectiveness can be strongly influenced by the human user and the particular environment in which it is used. This is precisely why interdisciplinary design teams are so essential, not only internal to the organization but external as well. Such teams can recognize and integrate the unique skills and specialized components of their trusted suppliers. Good human factors in design are not just about user-friendly, cosmetically appealing front panels. They extend all the way through a device, from components, to firmware, to network connectivity. In the context of Figure 1, consider how these individual elements often interact in subtle yet complex ways.

## Hospital environment

### Noise levels

Hospital ambient noise levels can affect safe and proper device operation in two critical ways:

- They can severely mask life-critical equipment alarms. Ventilator-dependent patients, for example, have died when such alarms cannot be heard.
- Excessive and persistent ambient noise may contribute to increased stress levels in patients and hospital staff. Persistent exposure to noise levels of 65–70 dB, while not known to cause hearing damage, has been shown to degrade task performance and cause temporary hearing threshold shifts. A variety of physiological changes also occur at such noise levels.<sup>[6]</sup>

A 2005 hospital noise study from Johns Hopkins University also concluded that “hospital noise levels have internationally grown steadily over the past five decades, disturbing patients and staff members, raising the risk of medical errors and hindering efforts to modernize hospitals with speech recognition systems.”<sup>[7]</sup>

### Facility design

Hospital patients are routinely moved throughout the facility, often connected to a variety of monitoring devices with their associated cables and fluid-filled catheters and tubes. Transporting patients connected to multiple devices through long, tortuous hallways and up and down elevators, crossing a number of flooring transitions and thresholds in the process, creates a variety of opportunities for accidental cable and tubing disconnects. What’s more, during these patient

transports the connected medical devices need to continue to function reliably on their internal batteries. Combined, these facility-related issues may contribute significantly to mishaps and mistakes. The physical environment has been implicated as the root cause of approximately 15 percent of the sentinel events reported to the Joint Commission on Accreditation of Healthcare Organizations (JCAHO)<sup>[8]</sup>.

### Air quality

Electronic medical devices, patients and their caregivers may also be adversely affected by:

- Temperatures that are either too hot or too cool, or temperature control that is widely fluctuating.
- Insufficient or excessive humidity and humidity control.
- Inadequate air filtering, surgical smoke evacuation or air exchanges.

Here, designers are encouraged to use the embedded intelligence and processing capacity within their products to monitor critical internal device temperatures and other factors, such as pressure differentials across air inlet filters, and alert the user to take appropriate action if necessary.

### Lighting levels

Glare from overhead or inappropriately placed task lighting can obscure instrument displays and can elevate worker stress levels.

### Human factors

When developing a new medical device, it is essential that the designer view the end product from the human user perspective. Namely, what human characteristics does the device need to cater to in order to be operated correctly and safely? In this regard, it is essential for medical device designers to consider human factors, such as the perceptual abilities associated with sight, hearing and touch, early in the design process. They should:

- Employ labels and displays that can be easily read and interpreted.
- Use colors and contrasts that minimize ambiguity and add information redundancy when possible, e.g., red alarm lights to further convey a dangerous condition.
- Recognize the implications for visually impaired users.
- Evaluate, in advance, to learn if viewing angle limitations, such as those associated with LCD or LED displays, are likely to be problematic under expected use conditions.
- Manage the tones, intensities and types of audible alarms, avoid the same combination of tones and intensities for differing alarm conditions, ensure that device alarms are distinct from the many other devices that are likely to be in use in the immediate working environment, and never provide the user the ability to permanently silence audible alarms or turn alarm volumes to less than ambient noise levels, i.e., 55–65 dB.

- Seek to make the alarm compatible with the level of the threat. Humans tend to equate both the volume and character of an alarm with its severity. In other words, do not assign an ear-splitting klaxon for a relatively minor alarm condition.
- Provide the user with tactile feedback whenever possible and appropriate. Humans possess touch receptors that are sensitive to both displacement and viscoelastic resistance. Positive detent push buttons and keypads communicate to users that their actions were sufficient. However, today there are new technologies, such as proximity capacitive sensing, that do not require positive detent push buttons. Users may lose the tactile response of pushing a button, but audio or visual (lights or LEDs) feedback can be programmed into the system to return a satisfactory response. These interfaces are also easier to clean and maintain, since users don't have direct contact with the circuits inside the device.

Many of these human perceptual design elements, for example, were incorporated into a (circa 1970's) cardiac defibrillator panel shown in Figure 2.

In particular, note the user-appropriate label “ECG SIZE” (as opposed to the then-popular term “Gain”), the numeric numbering of the positive detent, illuminated controls and the effective use of a single background color that indicates that all of the controls within this area are related even though there is no label that specifically points this out. Additional effective elements in this design include the use of redundant feedback mechanisms associated with many of the controls. The power on/off switch, for example, sends three different messages to users to indicate that they did something correctly when turning this device on. First, the “1” on the button says “press me first.” Second, the crisp detent of the switch provides tactile and audible feedback that this was done correctly. Third, the switch illuminates, indicating that the device is indeed on.

### User training

Inadequate training, or the lack of user training, has often been used to explain why clinicians make mistakes. Doing so, however, can often deflect users from uncovering device- or systems-related factors that may be the real culprit. Granted, proper education and training are important and vital to ensure that devices are used properly and safely. However, user training is rarely an effective substitute for user-friendly, intuitively obvious equipment design. Any medical device that requires hours of instruction and a voluminous operator's manual is not user-friendly. To continually promote training as a solution to the problem of medical error obscures larger system issues. An over-emphasis on training also tends to insult the intelligence of the device user.

### Machine

Poor medical device design and the lack of usability testing have been repeatedly discussed as being key factors in many device-related incidents.<sup>[9] [10] [11] [12]</sup> While the FDA and many medical device manufactures have made considerable progress in addressing the importance of human factors in device design, pre-market and pre-purchase usability studies continue to be under-utilized. Consider, for example, the differences in the front panel design of two infusion pumps shown in Figure 3. In particular, note the conventional (and familiar) telephone keypad layout in the pump on the right in contrast to the less familiar layout pattern used with the pump on the left. Such subtle differences can affect the speed and accuracy of data entry, and the lack of standardization also invites user mistakes.

### Human-machine interface

The human-machine interface is perhaps the most dynamic and complex element within the device/user environment. It is the point of engagement between the human and the machine. As the device is attempting to communicate with its user through visual and audible displays, indicator lights, color-coded

Cardiac Defibrillator Panel

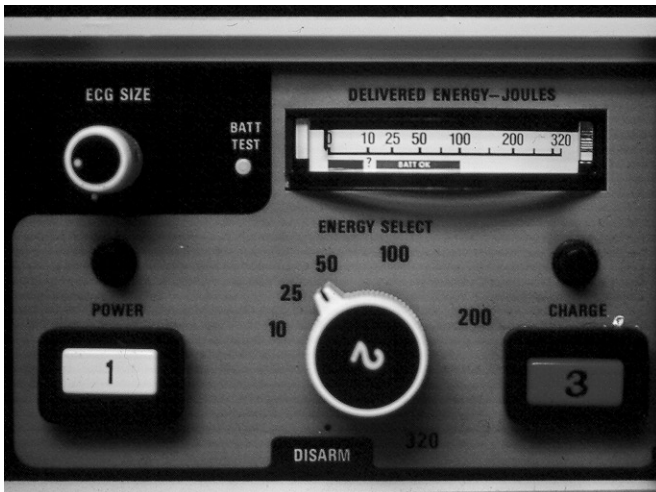

Figure 2

Traditional vs. Non-Traditional Keypad Layouts

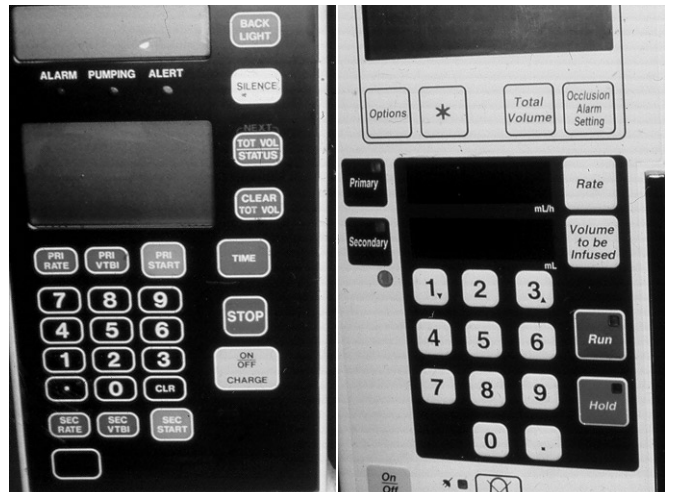

Figure 3

controls, icons, control panel design, function and labeling, the user attempts to perceive, interpret and respond to these stimuli in a timely and appropriate manner. In this regard, the human-machine interface is effectively its own closed-loop stimulus-response system. It is also here where much of what is conveniently but inappropriately labeled "user error" occurs. To blame the user, however, for device designs that allow, invite or encourage the user to make inappropriate responses, while convenient, is often not warranted. It is also at this human-machine interface where users express much of their frustration, which can be violent, damaging the device or even the user. While this might result in a missed movie or broken DVD player at home, the same conflict, when attempting to use an infusion pump, ventilator or defibrillator, may result in compromised patient care.

### Applicable codes and standards

After reviewing some of the factors that may affect the intended use of a device, it is important to mention that standards have been defined, some of them being relatively new. They include key features and strategies that suggest how to design better and more efficient medical devices in order to reduce or even eliminate mistakes. The U.S. Food and Drug Administration (FDA) has increasingly recognized the value of human factors in medical device design and encourages manufacturers and designers to adopt appropriate sections from the following available standards.

## ANSI/AAMI HE74:2001 Human factors design process for medical devices

The AAMI Human Factors Engineering Committee developed this process-oriented standard to provide manufacturers with a structured approach to user interface design, helping them develop safe and usable medical devices. It also helps them respond to the increasing number of national and international human factors standards in the medical field and the promulgation of new governmental regulations (based on ISO 9001) pertaining to medical device user interface design<sup>[13]</sup>.

This standard includes an overview of the human factors engineering (HFE) discipline, a discussion on the benefits of HFE, a review of the HFE process and associated analysis and design techniques and a discussion on implementation issues and relevant national and international standards and regulations.

### Improving usability

Medical device users (e.g., physicians, nurses, therapists, technologists, patients and service personnel) regard usability as one of the most important design considerations. They understand that a highly usable medical device is likely to

reduce the amount of end-user training time and will help clinicians be more productive. With devices intended for unsupervised patient use, such as home glucose monitors for diabetics, ease-of-use can affect whether the patient will be able to use the device at all. Medical device manufacturers will be well served by investing the necessary resources to improve usability. From a business standpoint, the potential payoffs from this investment may include:

- Faster time to market (by avoiding user interface problems late in the development cycle)
- Simpler user manuals and related learning tools
- Improved marketing through credible claims about a device's usability and associated gains in user productivity
- Increased sales (attributable to enhanced user interface quality)
- Reduced customer training and support requirements
- Extended market life
- Clearer compliance with regulatory requirements
- Reduced exposure to liability claims
- Increased user satisfaction

## IEC 62366:2007 Medical devices—application of usability engineering to medical devices

This standard was developed to help manufacturers improve the usability and safety of medical devices. The standard recognizes that the use of all medical devices has associated risks and provides an engineering process for identifying, assessing and mitigating those risks.

IEC 62366 describes a process that addresses medical device use errors and divides those errors into categories to guide their analysis. This process can be used to assess and mitigate risks caused by the usability problems associated with the normal and abnormal use of a medical device. As shown in Figure 4, use errors can be first separated by whether there were intended or unintended user actions or inactions<sup>[14]</sup>. All unintended actions, as well as intended actions that are categorized as either mistakes or correct use, are considered to be part of normal, and thus foreseeable, use. The manufacturer can only be responsible for normal use. Abnormal use errors are outside the scope of manufacturer responsibility, and they need to be controlled by the hospital.

If the designer complies with the usability engineering process detailed in this standard, the residual risk associated with device usability is presumed to be acceptable. Patient safety will improve as future medical devices are designed to comply with this standard.



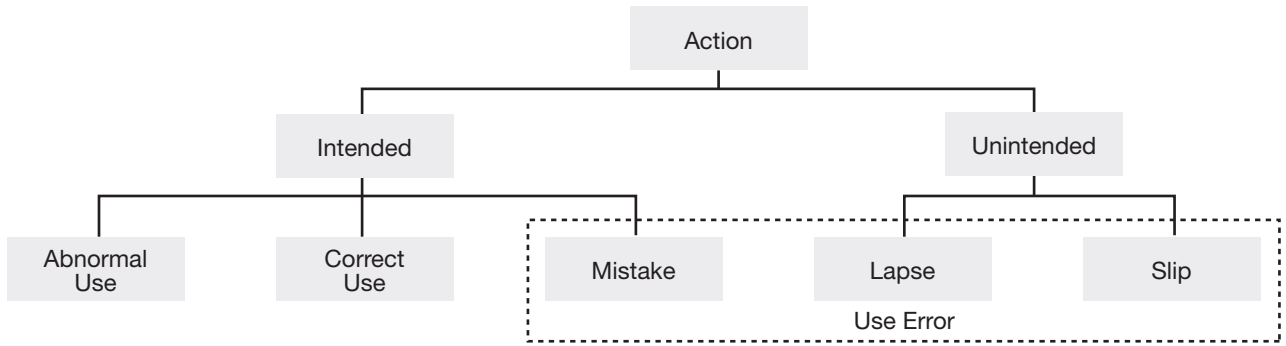

Figure 4

## Conclusions

The safe and proper use of medical devices can be dramatically improved when established human factors concepts are integrated early and applied throughout the design process. The incremental costs to do so are often negligible, but the payback can be tremendous. Improved user satisfaction, reduced use-related errors and a reduction in adverse patient outcomes are often the results. Freescale is helping make the medical world a smarter and safer place with a new generation of powerful, high-quality medical semiconductor products. With its wide product portfolio and support ecosystem, Freescale can help developers find the perfect fit for their next medical device product design. Simply put, a human factors approach to medical product design plus advanced semiconductor technology makes for better, intrinsically safer products—and a safer health care environment.

## References

- [1] Health Grades, Inc. "Patient Safety in American Hospitals," July 2004. Available at [www.healthgrades.com/media/english/pdf/HG\\_Patient\\_Safety\\_Study\\_Final.pdf](http://www.healthgrades.com/media/english/pdf/HG_Patient_Safety_Study_Final.pdf). Accessed December 31, 2004
- [2] Institute of Medicine. "To Err is Human: Building a Safer Health System," Washington DC: National Academy Press, 1999
- [3] "Aviation Industry Provides Roadmap to Improve Patient Safety," Hart CA, Biomedical Instrumentation & Technology. 2004; 38(6):466-9
- [4] "Human Factors in Engineering and Design," Sanders MS, McCormick EJ, New York: McGraw-Hill, 7th ed., 1993
- [5] "Human Factors in Systems Engineering," Chapanis, A., John Wiley
- [6] "Ergonomics: How to Design for Ease and Efficiency," Kroemer, K, et al., 2nd ed, New Jersey. Prentice-Hall, 2001
- [7] [www.jhu.edu/news/home05/nov05/noise.html](http://www.jhu.edu/news/home05/nov05/noise.html). Accessed November 4, 2008
- [8] Joint Commission on Accreditation of Health Care Organizations. Sentinel event statistics: September 30, 2004. Available at: [www.jcaho.org](http://www.jcaho.org) Accessed December 31, 2004
- [9] "Human Factors in the Health Care Facility," Welch DL, Biomed Instrum Technol. 1998, 32(3):311-6
- [10] "Poor Interface Design and Lack of Usability Testing Facilitate Medical Error," Fairbanks RJ, Caplan S, Joint Commission Journal on Quality and Safety, 2004; 30(10):579-584
- [11] "Human Factors Engineering and Patient Safety," Gosbee J, Qual Saf Health Care. 2002; 11:3524
- [12] "Design Paradigms: Case Histories of Error and Judgment in Engineering," Petroski, H, Cambridge University Press, 1994
- [13] ANSI/AAMI HE74:2001, "Human Factors Design Process for Medical Devices" (Arlington, VA: AAMI, 2001)
- [14] IEC 62366:2007, "Medical Devices—Medical Devices" (Geneva: IEC, 2007)

Larry Fennigkoh, Ph.D., professional engineer, is currently a professor with the biomedical engineering program at the Milwaukee School of Engineering, Milwaukee, WI USA. Diego Haro, bachelor of science in electrical engineering, was formerly a system solutions engineer at Freescale Semiconductor.



Rogelio Reyna and Kim Tuck with Dr. Daniel Copado

# Beyond Accidental Falls

## Human fall detection using accelerometry

Accidental falls are a widespread health hazard and a significant cause of death for people above 65 years of age. Thirty percent of reported falls that require medical attention involve people 65 years or older and 40 percent of the victims are above 80 years old. Over the age of 85, two-thirds of the falls are directly linked to the victim's death. In elder shelters and retirement homes, 66 percent of the residents report at least one fall each year. However, many accidents are not reported, therefore the frequency of falls is probably underestimated.<sup>[7]</sup>

However, by using Freescale's MMA7260Q triaxial accelerometer, 56F8013 digital signal controller (DSC) and MC13192 RF transceiver, a person's fall can be detected and reported for immediate response. This paper describes a reference design to recognize and analyze many human fall situations once they have occurred. It also details the hardware and software developed to implement such an approach.

### Introduction

Health care services have estimated that two thirds of the falls in the senior population could have been prevented. Identifying the risk factors, which are either intrinsic (host) or extrinsic (environment), is an essential first step toward developing a technologically advanced fall detection and reporting system. Intrinsic factors include such symptoms as vertigo, dizziness, weakness, confusion, impaired proprioception and other walking problems. Environmental factors can include slippery surfaces, uneven surfaces, deficient lighting and various obstacles.

When evaluating and treating the elderly as well as developing new systems to help protect them from accidental falls, some important axioms in gerontology (the study of the social, biological and psychological aspects of aging) should be considered.

- The notion of functional reserve: This is a redundant function present in virtually all physiological systems. A significant amount of this function can be lost over time before clinical symptoms appear.
- Aging is heterogeneous: The variability between physiological elements increases with age, and there can be a wide discrepancy between chronological and biological age. For this reason, it is difficult to examine the effect of age in some body systems.
- The decline in total functionality: This approximately equals the sum of the functional losses in the physiological system. When only one of the system's components is lost, compensating mechanisms maintain functionality. When multiple losses occur, any compensation is heavily compromised, resulting in lost functionality in the body as a whole.
- The consequences of deteriorated mobility and poor balance: This can vary depending on the social, emotional or behavioral environment. An effective network of social support and a healthy sense of judgment can mitigate the effect of poor balance and reduce the chance of falling.

Fall prevention is very important, but when these events do occur, prompt medical attention is required. Evaluating a fall victim requires the combined multidisciplinary work of doctors, therapists, psychologists and nurses. Their response time can be greatly improved by integrating accelerometer-based technology into the emergency network to provide prompt and accurate reports of falls.

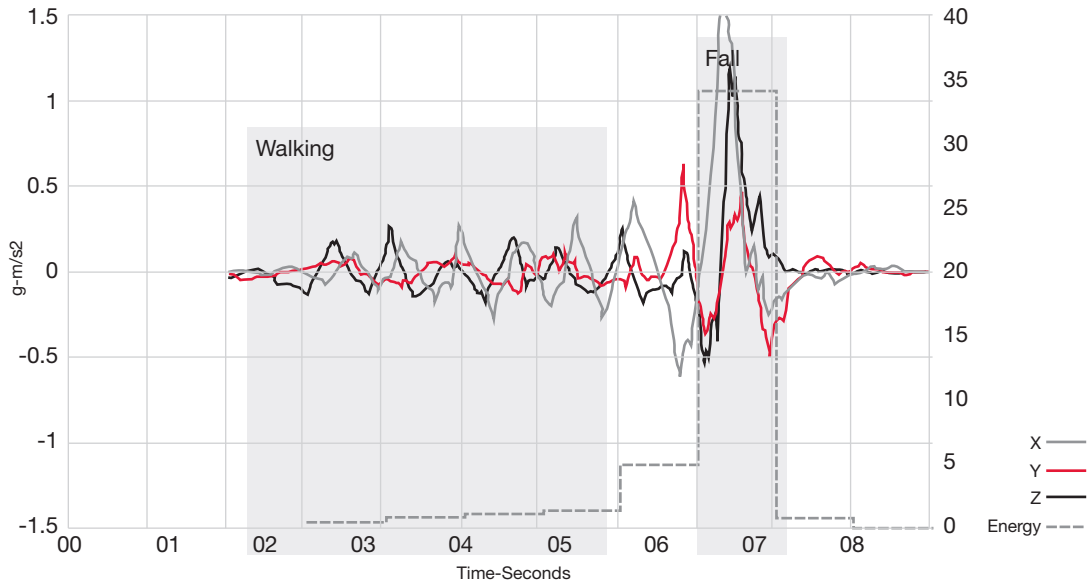

Figure 1

The key is that the first fall is reported. Once the accelerometer senses a fall, and the information is processed and transmitted to the care givers, the whole support and evaluation system can swing into gear to treat the patient, discover all the physiological, psychological and environmental reasons for the fall and follow up with preventative measures.

A psychologist or a social worker can gather information about social and financial well-being, any symptoms of depression, the current state of cognitive functions and other factors that might increase the probability of a fall.

The physical therapist can gather information about any physical deterioration of function that may indicate specific disabilities that could contribute to a fall.

The doctor's role is vital in this evaluation. He or she can determine the clinical history of the patient and recommend using an accelerometer-based fall monitoring system to track falling conditions. This can help the doctor adjust treatment as necessary. The clinical history may include:

- Drugs currently prescribed for use by the patient (hypnotics, sedatives, antidepressants, tranquilizers, antihypersensitives and others)
- Medical situations that could contribute to patient instability (neurological damage, cardiovascular conditions, blindness, history of ear damage, etc.)
- Illnesses that manifest in balance disorders or metabolic conditions that increase patient instability (important information for estimating the probability of another fall)

## Monitoring human motion

A human fall detection system can be viewed as a subsystem of a human activity monitoring system. Several studies ([1], [2], [3], [4] and others) have investigated systems that monitor human activities, and different sensing technologies have been evaluated, including the use of accelerometers to measure human movement.

Freescal's human fall detection reference design is based on accelerometry, which has the following advantages:

- Accelerometers are small and can be easily attached to the body.
- They can be easily interfaced with a portable processing unit.
- They are low-power sensors.

The accelerometer is only a sensor and therefore is only an input into a monitoring system. The real value in the system is the analysis from the sensor inputs that is used as a monitor of the human activity. This requires processing the accelerometer's input, computing the human state and communicating to a network to report the current state or an alarm condition.

## Algorithm

After reviewing different approaches to the human fall detection problem, the methodology selected for the human activity monitor is defined in the paper, “Determining Activity Using a Triaxial Accelerometer”.<sup>[1]</sup> Its adoption into the reference design is briefly described below:

- The Freescale MMA7260Q triaxial accelerometer is measured at 45 Hz.
- An order 13 median filter is applied to the accelerometer samples to remove the noise spikes.
- A high pass FIR filter with a cut-off frequency of 0.25 Hz over a non-overlapping window of 0.8 seconds (36 samples) is used to remove the gravity component in order to stay with the dynamic acceleration data. This is required for computing the next stage.
- There is an energy expenditure computation stage on each window. Figure 1 plots the data on the signals out of the FIR filter and the energy expenditure. As found in “Determining Activity Using a Triaxial Accelerometer,” a non-overlapping window of 0.8 seconds is good enough for determining human activity using a device attached to the waist.
- The energy expenditure computation over each window is then compared with specific thresholds for determining the human activity, such as stand, walk and fall. This is done by comparing the energy expenditure level of each activity with a set of thresholds determined by experimentation. The system recognizes a fall because the impact of the human body creates the highest energy expenditure threshold value in the system. Please refer to the Conclusion section of this article for recommended work to increase the reliability of the system.

## Development process

1. Setup and experimentation
  - a. The experimentation setup consisted of a board with an IEEE® 802.15.4 transceiver and accelerometers, another 802.15.4-enabled board connected to a laptop through an RS232 connection and a comfortable cushion (allowing the test subjects to fall without injury). These were used to gather the source information for evaluating the algorithms used offline.
  - b. Ten men were asked to execute 21 sequences, three times each. These included: walking then falling, jogging, running, walking upstairs and walking downstairs.
2. Documentary research and determining the algorithm
  - a. Looked for papers on the Web, specifically on IEEE.org.
  - b. Reviewed papers and selected the algorithm suggested in “Determining Activity Using a Triaxial Accelerometer.” It was selected because it uses a triaxial accelerometer and the details on the algorithm are provided with good results.

3. Creating a model and validating the algorithm
  - a. Created the model of the selected algorithm using Matlab® and the digital signal processing toolbox.
  - b. Used the created model, with the log files as input, to simulate the output of the algorithm. This was performed only for a couple of sequences (the objective was to classify a human fall, not a complete set of human activities).
  - c. Performed minor modifications to the algorithm, such as determining the order of the FIR filter to better suit the application (to fit the 0.8 second window).
  - d. Used the data to create the classes (thresholds) of the energy expenditure values for standing, walking and falling.
  - e. Used part of the data to test the thresholds.
4. Implementing the model in the DSC
  - a. Once the algorithm was tuned and working, the floating point data types were changed to fixed point to make it suitable for the DSC.
  - b. The software architecture was defined and implemented in the DSC through a serial interface.
  - c. Used the serial interface to load the log files data and validated the algorithms running in the 56F8013 DSC.
5. Implementing the remaining requirements
  - a. Wireless communication, flash driver and serial communication modules were implemented.
6. Validating the reference design
  - a. After being developed, the reference design was evaluated using a small group of people.

## System requirements

In order to make it suitable for its intended use, a human fall detection device should meet the following requirements:

- It is small and inconspicuous and can be easily attached to the person.
- It is battery powered.
- It senses a person’s fall by detecting the impact then reports the fall after it has occurred to a base station, where it is stored in nonvolatile memory.
- The device can receive and execute commands from the base station to control the nonvolatile memory.

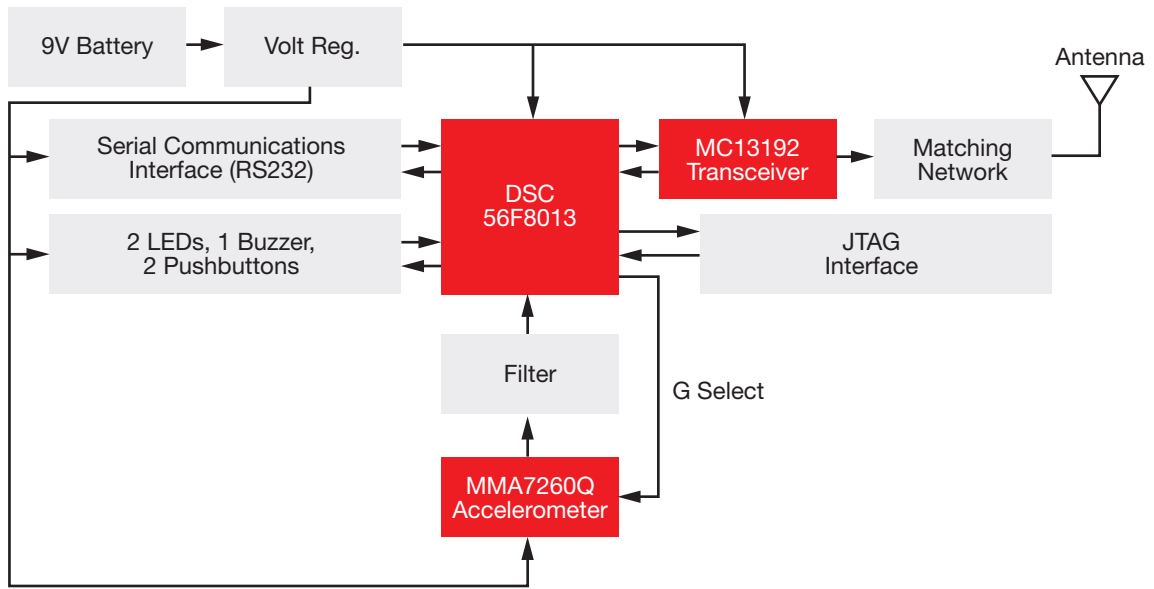

Figure 2

Software Tasks

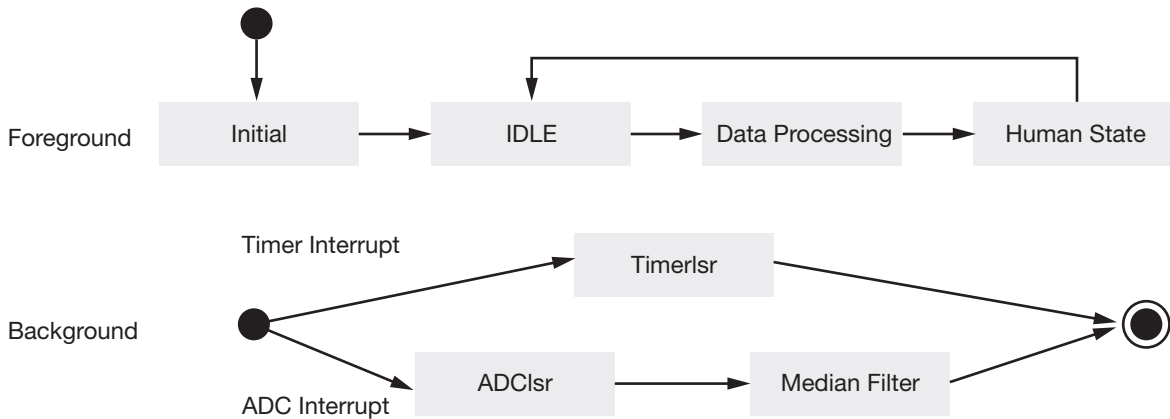

Figure 3

### Hardware description

The triaxial accelerometer provides three analog signals corresponding to the sensed acceleration in each axis. G selection is controlled directly by the DSC and is used to determine the sensitivity of the device (+/-1.5g was selected). The power-save pin is connected to  $V_{DD}$  to allow the accelerometer to be on constantly. In the current approach, there is no need to change the sensitivity range of the accelerometer; however, future implementations may require changes in order to provide the system with more information on a specific human body movement.

The 56F8013 DSC controls the behavior of the accelerometer (MMA7260Q), the user controls and indicators, the I<sup>2</sup>C memory and the RF transceiver (MC13192). It processes the accelerometer outputs to generate information about the human subject's state and determines whether he or she has fallen or not.

The RF transceiver allows the system to wirelessly report an event or emergency to a base station. It is also the way to access the data on the I<sup>2</sup>C memory. The size of the memory depends on how many events you are willing to store. A 32 KB memory was used in this design. The protocol used to transmit the data is a modified version of SMAC4.1, which is available at [www.freescale.com](http://www.freescale.com).

## Software description

The software is divided into two main tasks—a background task and a foreground task.

The background task processes the accelerometer signals to detect the human state. The foreground task responds to hardware events, such as interrupts generated by IRQs, the analog-to-digital converter (ADC) and communication modules (UART and Simple MAC).

With the ADC sampling at 45 Hz, the algorithm used to detect a fall relies on digital signal processing in the following stages:

- 13th order median filter applied to the ADC samples to remove the very high frequency noise.
- 30th order high pass filter with a cut-off frequency of 0.25 Hz to remove the gravity component.
- Energy expenditure computation stage that compares with specific thresholds for determining the human activity, such as stand, walk and fall.

## Results

The initial scope of this project was to generate a simple reference design that Freescale customers can use for developing their own products. Given this, and regardless of the multiple data points that can be gathered, only three human activities were characterized—standing, walking and falling.

Given this scope, no further evaluation of the generated solution was performed. You should be able to reproduce this reference design by reading “Human Fall Detection Using a 3-axis Accelerometer,” downloadable from [www.freescale.com](http://www.freescale.com) (search for document number MMA7260QHFRM)<sup>[6]</sup>.

To further improve system reliability and flexibility, an historic windows analysis could be performed to detect a fall or even prevent some of them.

Energy expenditure values together with gravity information (for detecting a free fall condition and tilt) will generate a more reliable system response.

## Conclusion

Freescale is well-positioned to enable this application with its current portfolio of low-power 8-bit and 32-bit microcontrollers, DSCs, low-power accelerometers and 802.15.4 transceivers.

This human fall detection device is only part of a complete system that could allow prompt response in the event of an accident. Other parts of the system would include a device that could wirelessly receive the fall event and issue an accident report to a telemonitoring central station. This station could, in turn, attach the actual conditions of the person (as outlined in this article's introduction) to the fall information received and alert medical or emergency services as well as call or page family members to alert them of the accident.

## References

- [1] “Determining Activity Using a Triaxial Accelerometer,” M. J. Mathie, N. H. Lovell, A. C. F. Coster, B. G. Celler, Second Joint EMBS/BMES Conference, 2002
- [2] “A Triaxial Accelerometer and Portable Data Processing Unit for the Assessment of Daily Physical Activity,” C.V.C Bouten, K.T.M. Koekkoek, M. Verduin, R. Kodde, J.D. Janssen, IEEE Transaction on Biomedical Engineering, 1997
- [3] “Detection of Static and Dynamic Activities Using Uniaxial Accelerometers,” P. H. Veltink, H.B.J Bussmann, W. de Vries, W.L.J. Martens, IEEE Transaction on Rehabilitation Engineering, 1996
- [4] “Activity Monitoring with Accelerometry,” H.B.J. Bussmann, P.H. Veltink, W.L.J. Martens, H.J. Stam, 1994
- [5] “Exploring the Information Content and Some Applications of Body Mounted Piezo-Resistive Accelerometers,” W.L.J. Martens, Symposium supplement, “Dynamic Analysis Using Body-Fixed Sensors” of the 2nd World Congress of Biomechanics, 1994
- [6] “Human Fall Detection Reference Design” [www.freescale.com/files/sensors/doc/ref\\_manual/MMA7260QHFRM.pdf?fsrch=1](http://www.freescale.com/files/sensors/doc/ref_manual/MMA7260QHFRM.pdf?fsrch=1)
- [7] CDC (Centers for Disease Control and Prevention) [www.cdc.gov/NCIPC/FACTSHEETS/ADULTFALLS.HTM](http://www.cdc.gov/NCIPC/FACTSHEETS/ADULTFALLS.HTM)

Rogelio Reyna is a software engineer working with the Sensors and Actuators Solution Division at Freescale Semiconductor. Kimberly Tuck has her degree in systems design engineering from the University of Waterloo. She has MEMS design experience and worked as a MEMS applications engineer for five years in a research environment designing tools for various micro assembly projects. For the past two years she has been working in the consumer and industrial sensors segment as an applications engineer focused on accelerometers for Freescale. Dr. Copado is a four-year resident of Traumatology and Orthopedic Surgery at the Mexican Institute of Health Hospital with an expertise in hip replacement.



Jaime Herrero with Dr. José Fernández Villaseñor

## Changing the High-Complexity Paradigm

### Simplifying health and safety solution designs

#### Introduction

People worry about their health and safety, and today they ask for compact, portable, easy to use and attractively designed personal equipment that accomplishes specific safety and health objectives.

This article focuses on using Microsoft® .NET Micro Framework for designing home medical appliances and provides tips on how to give the end product the look and feel that customers demand. This can be accomplished by designing attractive graphic interfaces, integrating connectivity through various communication interfaces (UART, I<sup>2</sup>C, SPI, Ethernet, USB, Wi-Fi) and enabling the performance of the i.MX microprocessor. The result can be a high-end monitoring solution, such as blood glucose meters, or any number of other health and safety devices designed to satisfy specific customer needs. These appliances are differentiated by price, functionality, ease of use and look and feel.

When chronic degenerative diseases, such as diabetes, strike young people, clinicians face a greater challenge getting patients to cooperate with the data acquisition (illness monitoring) required to gain better control of the disease. For instance, diabetic teenagers tend to turn off alarms for hyperglycemia in glucose continuous monitoring systems, which can result in the loss of glycemic control over longer periods of time (see Table 1). However, integrating multimedia functionality with the monitoring system may encourage patients to make better use of the instrument, including responding to any alarms.

| Glycemic Control Targets from the ADA, ACCE and IDF |                |             |             |
|---|----------------|-------------|-------------|
|   | ADA            | ACCE        | IDF         |
| HgA1c   | <7.0           | ≤6.5        | ≤6.5        |
| Fasting/<br>preprandial                             | 90–130 mg/dL   | <110 mg/L   | <100 mg/dL  |
|   | 5.0–7.2 mmol/L | <6.1 mmol/L | <5.6 mmol/L |
| 2-hour<br>postprandial                              | <180 mg/dL     | <140 mg/dL  | <135 mg/dL  |
|   | <10.00 mmol/L  | <7.8 mmol/L | <7.5 mmol/L |

#### Duration of Hyper, Hypo and Normoglycemic State During Continuous Glucose Monitoring System (CGMS in 17 Children and Adolescents with Type 1 diabetes)

|               |                | Duration of Glycemic State during CGMS 72h |             |
|---------------|----------------|--|-------------|
|               |                | Minutes                                    | Percent     |
| Hypoglycemia  | (<70 mg/dl)    | 224  | 4.7 ± 3.39  |
| Normoglycemia | (70–180 mg/dl) | 1650                                       | 38.0 ± 27.9 |
| Hyperglycemia | (>180 mg/dl)   | 2446                                       | 57.3 ± 29.4 |

Table 2

Source: Taken from "Efficacy of continuous glucose monitoring system to detect unrecognized hypoglycemia in children and adolescents with type 1 diabetes," Frederico F.R. Maia and Levimar R. Araujo

Personal medical appliances can also be used for general wellness and fitness applications as well as for chronic degenerative diseases. Integrating advanced software and hardware components into highly functional and intelligent designs is critical to successfully create the future health and safety applications that will be used by millions of people. This article describes an easy way to develop small and cost-effective solutions through .NET Micro Framework and the i.MX microprocessor family.

#### i.MX applications processor and .NET Micro Framework

Freescale's i.MX family of applications processors is based on ARM® core technology and is optimized for multimedia applications. .NET Micro Framework can be ported to these processors to enable them with the features that come with the software.

.NET Micro Framework is the most compact .NET Framework offered by Microsoft and is configurable for the smallest memory footprint (64 KB RAM, 256 KB flash). This framework is optimized for embedded devices, offering full use of the most common tasks associated with embedded development without the overhead of unnecessary tasks featured in the complete .NET Framework. It enables developers to use the communication ports (Ethernet, Wi-Fi, USB, serial, SPI, I<sup>2</sup>C), LCDs (drawing directly in the canvas or through visual

components), touch screens and storage (flash, RAM, SD/MMC). Due to its architecture, .NET Micro Framework is limited to running just one application, but it allows multiple tasking. The .NET Framework libraries have the most common objects and functionality, and their use requires a license from Microsoft.

Freescale offers the i.MXS applications processor for use with .NET Micro Framework. The processor features include:

- ARM920T™ core, operating at 100 MHz
- Color LCD controller
- Direct memory access controller (DMAC)
- External interface module (EIM)
- SDRAM controller (SDRAMC)
- A variety of connectivity peripherals (SPI, USB and UARTs)
- Power-saving modes to provide exceptional performance while lowering the overall power budget and system cost

The .NET Micro Framework port lets the users develop embedded applications using Microsoft Visual C#. This takes advantage of the high-end programmers' skills and enables them to develop embedded applications.

The toolset required to develop i.MXS embedded applications for health and safety using .NET Micro Framework includes:

- Microsoft Visual Studio 2008
- Microsoft Visual C#
- .NET Micro Framework
- USB cable
- i.MXS development board

For more information on .NET Micro Framework, visit [www.microsoft.com/netmf](http://www.microsoft.com/netmf).

## Design tips and considerations

Following are design tips and considerations that can be applied when designing graphical user interfaces (GUIs) and data monitoring functionality. Developers with C# programming skills are able to configure the hardware for the special needs of the health and safety embedded applications.

### General purpose input output (GPIO)

Almost all health and safety assets use GPIOs to configure LEDs (to show any special device status), special keys (reset, test mode, calibration) and signaling (additional interrupts to detect an accurate sensor read). .NET Micro Framework allows GPIOs to be configured by the following three ways, depending on the application needs:

#### 1. As input pin

```
InputPort inputPin = new InputPort(Pins.GPIO_PORT_C_5, true, Port.ResistorMode.PullUp);
if (inputPin.Read()) runInputAction();
```

#### 2. As interrupt pin

```
InterruptPort interruptPin = new
InterruptPort(Pins.GPIO_PORT_C_6, true, Port.
ResistorMode.PullUp, Port.InterruptMode.
InterruptEdgeHigh);
interruptPin.OnInterrupt += new GPIOInterruptEvent
Handler(inputPinInterrupt_onInterrupt);
```

#### 3. As output pin

```
OutputPort outputPin = new OutputPort(Pins.GPIO_PORT_C_7, true);
outputPin.Write(true);
```

The configuration of threads is as follows:

```
Thread t1 = new Thread(new ThreadStart(thread1));
t1.Priority = ThreadPriority.Highest;
t1.Start();
```

### Storing data in memory

Storing data in flash is another common task in embedded development. Metrics are stored in several different kinds of medical devices, such as blood pressure monitors and blood glucose meters. To store data in flash using .NET Micro Framework, follow these steps:

#### 1. Create a serializable class

```
[Serializable]
public class Device
{
    private String name;
    private byte value;
    public String Name
    {
        set { name = value; }
        get { return name; }
    }
    public byte Value
    {
        set { value = value; }
        get { return value; }
    }
    public Device(byte Value, String Name)
    {
        value = Value; name = Name;
    }
}
```

## 2. Create a serializable log of the class

```
[Serializable]
class DeviceLog
{
    private ArrayList log = new ArrayList();
    public ArrayList Log
    {
        get { return log; }
    }
    public void AddToLog(Device device)
    {
        log.Insert(0, device);
    }
    public void RemoveFromLog(Device device)
    {
        log.Remove(device);
    }
    public void ClearLog()
    {
        log.Clear();
    }
}
```

## 3. Create and use a flash reference

```
ExtendedWeakReference flashReference;
uint id = 0;
public Object load()
{
    flashReference = ExtendedWeakReference.
RecoverOrCreate(
    typeof(Program), //
marker class
    id,
// id number in the marker class
    ExtendedWeakReference.c_
SurvivePowerdown); // flags
    flashReference.Priority = (Int32)
ExtendedWeakReference.PriorityLevel.Important;
    Object data = flashReference.Target; //
recovering data
    return data;
}
public void save(Object data)
{
    flashReference.Target = data;
}
```

## GUIs

.NET Micro Framework also helps the programmer develop attractive screen interfaces, which can be major purchasing differentiators for end customers and can influence the developer's choice of silicon vendors.

.NET Micro Framework running on the i.MXS processor offers two ways for the developer to configure the user interfaces. One is to use the user interface elements offered by .NET Micro Framework while the other is to use the bitmap class and flush its contents in the screen.

## User interface elements available in .NET Micro Framework

| User Interface Element | Description   |
|------------------------|---|
| Canvas                 | Defines an area or canvas within which you can explicitly position child elements by using coordinates that are relative to the upper left corner of the canvas |
| Image                  | Displays a bitmap image   |
| ListBox                | Implements a list of selectable items   |
| ListBoxItem            | Implements a selectable item inside a ListBox object  |
| Panel                  | Constitutes a base class for all panel elements   |
| StackPanel             | Arranges child elements (child objects) in a single line that can be oriented either horizontally or vertically   |
| Text                   | Displays a block of text  |
| TextFlow               | Provides members that control how text flows on the display device (screen)   |
| TextRun                | Provides members you can use to create and work with a text run, which is a string of characters that share a single property set                               |
| Shape                  | Represents a line or a two-dimensional shape displayed on a hardware display device. The implemented shape objects are: ellipse, line, polygon and rectangle.   |

Table 3

In a similar way, all the elements in the table above are programmed as follows:

```
// Create a panel
StackPanel _panel = new StackPanel();
_panel.Height = _mainWindow.ActualHeight;
_panel.Width = _mainWindow.ActualWidth;
// Create and configure user interface elements
Text textTitle = new Text();
textTitle.Font = Resources.GetFont(Resources.
FontResources.small);
textTitle.TextContent = "Title Text";
textTitle.HorizontalAlignment = Microsoft.SPOT.
Presentation.HorizontalAlignment.Center;
textTitle.ForeColor = (Microsoft.SPOT.Presentation.
Media.Color)0xFF0000;
// Add the user interface elements to the panel
_panel.Children.Add(textTitle);
```

The code above starts creating the panel object, then its dimensions are specified, the text object is created and its font, text, alignment and color properties are defined. Finally, the text object is added to the panel's children stack.

Once the user interface element has been added to the display panel, the only way to update the element's content is through an asynchronous update, as illustrated by the following code:

```
delegate void UpdateTitleTextDelegate(String hint);
private void UpdateTitleText(String text)
{
    if (textTitle != null) textTitle.TextContent =
text;
}
```

```
// When the update of the textTitle is required,
use the following code
_mainWindow.Dispatcher.Invoke(
new TimeSpan(0, 0, 1),
new UpdateTitleTextDelegate(UpdateTitleText),
new object[] { "New Title Text" });
```

When the bitmap class is used and flushed in the screen, the item's location and the screen rendering is not automatic. The developer has to create code to perform location and rendering through functions, state variables, timers and threads. Following is a simple example of this process:

```
Bitmap _back = new Bitmap(240, 320); // bitmap
used for flush
Bitmap _screen = new Bitmap(240, 320); // based
bitmap to be updated
Font font = Resources.GetFont(Resources.
FontResources.small);
_back.DrawImage(35, 10, Resources.
GetBitmap(Resources.BitmapResources.freescale), 0,
0, 170, 57);
_back.DrawRectangle(Color.White, 1, 35, 10, 170,
57, 2, 2, Color.White, 0, 0, Color.White, 240,
320, 0);
_screen.DrawImage(0, 0, _back, 0, 0, 240, 320);
_screen.DrawTextInRect("State: Background", 10,
300, 220, 20, Bitmap.DT_AlignmentCenter |
Bitmap.DT_TrimmingCharacterEllipsis,
(Color)0xFFFFFFFF, font);
_screen.Flush();
```

### Complex GUI with Interface Elements and Canvas

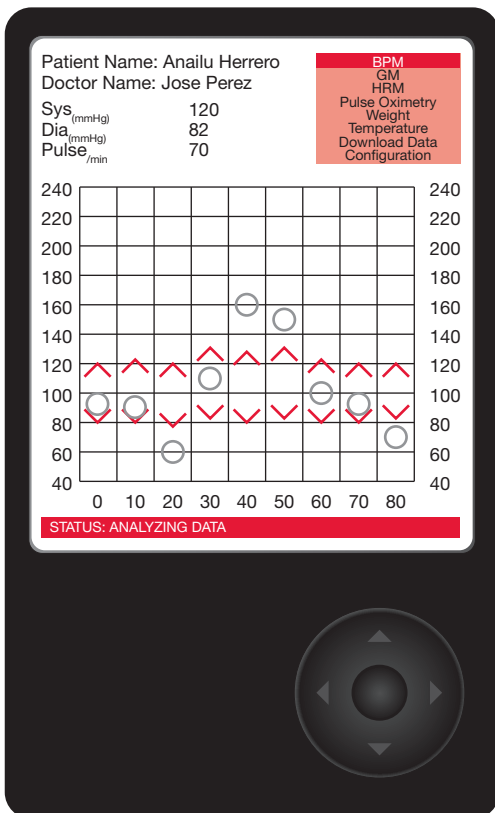

Figure 1

Graphical charts provide a way to verify historic data and perform analysis on this data. Personal health and safety devices commonly use graphics, such as bar charts and point charts, to display, in one format, several variables that are being measured. Two solutions for graphics handling are proposed below.

First, using the user interface element named Image, the developer can manipulate the information displayed, at pixel level, through the property bitmap.

#### Manipulating pixels in the image can be done through the following bitmap class methods

| Method         | Description from the Visual Studio .NET MF help           |
|----------------|---|
| Clear          | Clears the entire drawing surface                         |
| DrawEllipse    | Draws a filled ellipse on the display device              |
| DrawImage      | Draws a rectangular block of pixels on the display device |
| DrawLine       | Draws a line on the display device                        |
| DrawRectangle  | Draws a rectangle on the display device                   |
| DrawText       | Draws text on the display device                          |
| DrawTextInRect | Draws text in a specified rectangle                       |
| SetPixel       | Turns a specified pixel on or off                         |

Table 4

Second, using the user interface element named Canvas, the developer can manipulate the location and the user interface elements to display in a specific area, as illustrated in the following example code:

```
Canvas _canvas = new Canvas();
_canvas.Height = SystemMetrics.ScreenHeight;
_canvas.Width = SystemMetrics.ScreenWidth;
Shape shape = new Rectangle();
// Getting random numbers for width and height,
fixing the max number to the canvas size
shape.Width = Math.Random(_canvas.Width);
shape.Height = Math.Random(_canvas.Height);
shape.Stroke = new Pen(color);
shape.Fill = new SolidColorBrush(color);
// Setting the location in the canvas for the
element, these functions are static
Canvas.SetTop(shape, Math.Random(_canvas.Height -
shape.Height));
Canvas.SetLeft(shape, Math.Random(_canvas.Width -
shape.Width));
// Adding the shape to the canvas
_canvas.Children.Add(shape);
```

In the above code snippet, we are creating a new canvas object and defining its height and width. A rectangular-shaped object is created and the types of stroke, fill color and texture are defined. Finally, the location of the rectangular shape in the canvas is specified, and the rectangular shape is added to the canvas. Creating figures has never been easier, and all this is allowed by the .NET Micro Framework user interface elements, which are supported in the i.MXS microprocessor.

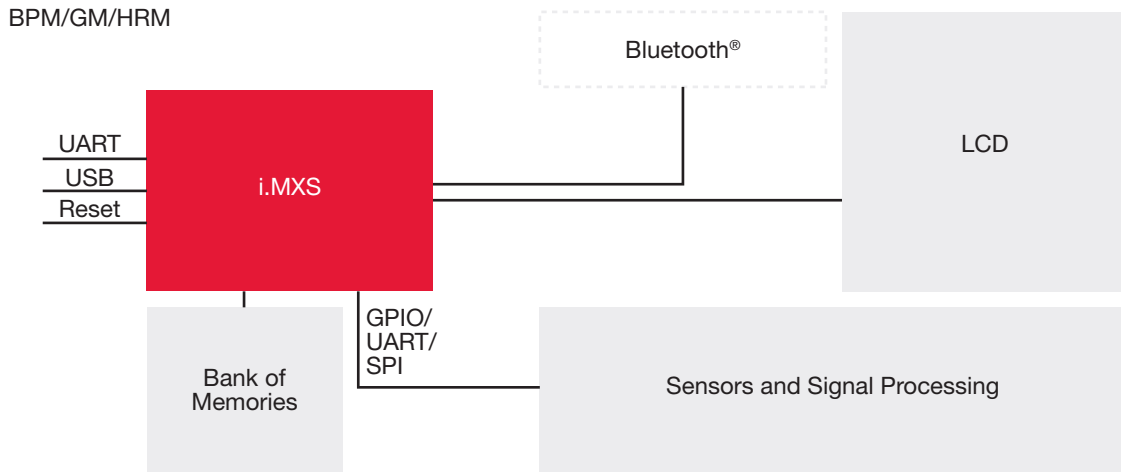

Figure 2

### Communications interfaces

Serial communications is a major component in all health and safety applications that transfers data from the device to a PC for analysis by the physician or patient.

Using such interfaces as UART, SPI, I<sup>2</sup>C, USB, Ethernet and Wi-Fi are common ways to feed data to a PC. In the following example, the lines of code enable a UART-based communication:

```
SerialPort serialPort;
// The configuration is through the SerialPort.
Configuration class
SerialPort.Configuration serialConfig = new
SerialPort.Configuration(SerialPort.Serial.COM1,
SerialPort.BaudRate.Baud115200, false);
serialPort = new SerialPort(serialConfig);
// The read is through the Read function that
returns the number of bytes read
numberOfBytesRead = serialPort.Read(strBuffer, 0,
READ_NUMOFCHARS, READ_TIMEOUT);
// The write is through the Write function
serialPort.Write(strBuffer, 0, strBuffer.Length);
```

Unfortunately, the serial port doesn't use interrupts to alert the application that a byte has been received or when the UART is ready to send a byte. The common way to check for a received byte is to monitor the return value of the Read method. Nevertheless, .NET Micro Framework lets developers work with threads and events and allows them to create a more complete class with an infinite loop into a thread that checks for a byte received.

Figure 2 is an example of a health care system block diagram powered by an i.MXS applications processor.

### Conclusion

The i.MXS processor and .NET Micro Framework are optimized for such applications as clocks, watches, remote controls, blood glucose meters, cholesterol meters and others. Using the i.MXS processor and .NET Micro Framework, the developer doesn't need to be a microprocessor expert to quickly design a visually attractive user interface. High level C# enables a high-end programmer to program code in a manner similar to programming a personal computer.

In summary, Microsoft and Freescale enable designers to develop attractive applications (a good look and feel adds value for the end user) that reach the market faster. Most importantly, continuous monitoring of an illness or condition can be made less painful and intrusive and can help improve the response to medical treatment.

Jaime Herrero is a systems and applications engineer in the Multimedia Application Division at Freescale Semiconductor. He has been in charge of developing embedded applications over .Net Micro Framework and Sideshow for i.MXS. Dr. José Fernández Villaseñor is a medical doctor and electrical engineer who combines his work at Freescale Semiconductor as a medical product marketer and his work as a hospital physician. He has more than eight years of experience working on automotive, industrial and medical engineering systems and applications as well as semiconductor product development.



Rodolfo Gonzalez

## Reducing DICOM

### Moving the standard to portable devices

In the last couple of decades not only has the use of digital medical imaging grown very rapidly, but the ability to share this information, in seconds, across the globe has maximized the usefulness of each image. Digital imaging and communication in medicine (DICOM) specifies a standard method for transmitting medical images and all the information related to them.

DICOM is the most common format used in picture archiving and communication systems (PACS), which is a medical network dedicated to the storage, retrieval, distribution and presentation of images. PACS is also helping hospitals move into what they call filmless storage and presentation. This way millions of films in yellow envelopes can be replaced with a 1- to 10-terabyte digital storage server. Figure 1 illustrates the main components of PACS.

All the information is concentrated on the server in the middle of the diagram. Acquired images from the different modalities are stored in the server, available at any time to be consulted by physicians and staff through the workstations inside the network. Also, the information can be published to a website so it can be viewed in clinics or hospitals around the world. All these transactions are done through DICOM.

#### PACS

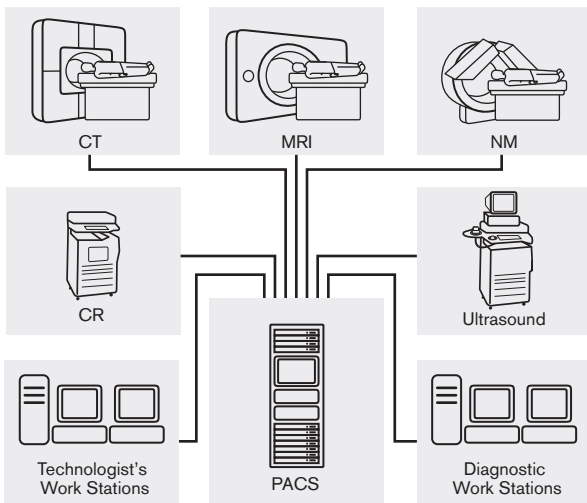

Figure 1

#### DICOM, a bird's eye view

The DICOM standard is a major evolution of its predecessor, ARC NEMA (American College of Radiology, National Electrical Manufacturer Association). DICOM applies to a TCP/IP networked environment from either online or off-line standard media, such as CD-R or external memory devices. One of the biggest differences between DICOM and ARC NEMA is that it has been structured as a multi-part document, which allows new features to be added rapidly.

DICOM files are composed of the header and the images. The header can include such information as personal patient data, type of study, equipment used, image dimensions, diagnostics, graphics, waveforms and reports, just to mention a few. What's more, each file can contain hundreds of images.

#### Typical DICOM File



Figure 2

Figure 2 shows a typical DICOM file. In this example, the first bytes are used by the header, which describes the tomography image dimensions. The size of the header can vary, depending on how much detail is included in the stored information. In this case it shows two images formed by a matrix of 201 x 134 voxels (a voxel is a volume element used to represent a value in three-dimensional space, just as a pixel represents a value in two dimensions). Images and data are stored in the same file.

The DICOM standard was created and is maintained by a committee of more than 20 health care vendors, 15 medical users and other medical stakeholders (see [medical.nema.org/members.pdf](http://medical.nema.org/members.pdf)). DICOM is now the standard used by most of the companies within the health care industry.

One of the goals the standard is trying to achieve is to facilitate the interoperability of different kinds of medical devices, such as those for radiology and cardiology. In other words, one of the goals for DICOM is to allow health care personnel to share images from different modalities from different vendors on the same network. In addition, the plan is to allow other image and non-image medical apparatuses to be interconnected. This last capability has not been fully explored. Thus far, most of the equipment with DICOM capabilities in the market is non-portable radiological instruments, such as those used for magnetic resonance imaging, computed tomography, fluoroscopy, mammography, ultrasound and others. These instruments are based on very powerful workstations with high-speed processors, large amounts of memory and storage capabilities and medical algorithms for image analysis. The effectiveness of using DICOM with these large instruments will continue to evolve, however the medical industry is rapidly incorporating more portable devices.

Portable home versions of such products as ultrasound units, blood pressure monitors, heart rate monitors and others are becoming part of the new generation of health care devices. These provide valuable health data to the patient at home, but transmitting the information to the care givers can be problematic. In the health care arena, hours, minutes or even seconds count, meaning the faster the specialist receives the information the better the medical response. Reducing this time could be the difference between life and death. Therefore, it is time for DICOM to move forward into portable image and non-image medical devices and make them a compatible part of the big network. Currently, it is very easy to receive Internet access at home or through a GPRS cellular service. This ease of access needs to be exploited to share the information gathered with all these portable medical devices.

## DICOM for portable devices

The medical market is demanding portable devices with DICOM services. This may require developing portable media players capable of accessing and downloading image data to be analyzed by specialists to determine a diagnosis. Currently, some radiologists are using commercial PDAs with DICOM viewer software to take an overview of the data. However, lower display resolution, reduced image processing capabilities and other limitations prevent radiologists from generating a diagnosis using such devices.

Since DICOM incorporates the images in a JPEG lossless format, a basic JPEG viewer could be used to display the image, but the user needs to be very careful about the resolution, gray scale, luminance, dark room contrast and other factors before generating a diagnosis. Studies have shown that five megapixels (MP) is sufficient for most of the radiographic studies, but for mammography more than ten MP is desired to generate a diagnosis (see [www.ieeexplore.ieee.org/stamp/stamp.jsp?arnumber=00673974](http://www.ieeexplore.ieee.org/stamp/stamp.jsp?arnumber=00673974)).

Two different kinds of displays are used in the medical arena. A commercial display is used to show the images for reference only. For making diagnoses, specialized medical displays with the features outlined in Table 1 are required.

### Primary Features Needed for Medical Displays

| Emission                        | Monochrome                                |
|---------------------------------|---|
| Maximum luminance               | >400 fl                                   |
| Addressable pixel matrix        | 4000 x 5000, minimal requires 2000 x 2500 |
| MTF at nyquist frequency        | 0.70                                      |
| MFT uniformity                  | ±0.05                                     |
| Large-area luminance uniformity | <±0.1 dB                                  |
| Intra-scene dynamic range       | >500:1                                    |
| Noise power spectrum            | White                                     |
| Total S/N per pixel             | >100:1                                    |
| Large-area distortion           | <±1%                                      |
| Refresh rate                    | Static or >72 Hz                          |
| Internal grey scale             | Perceptionally linear                     |
| Time to rewrite screen          | <1 sec.                                   |

Table 1

At present, medical display prices are out of reach for most of the small to medium sized hospitals or for independent radiologists. This situation obliges the users to acquire commercial monitors or LCDs that do not have all the features required for good diagnostics.

There are also those markets requesting radiology equipment upgrades. Hospitals in developing countries, for instance, need to move forward into a DICOM environment but cannot afford to replace all the medical equipment they already have. For example, more than 50 percent of the hospitals in

## Hardware/Software DICOM Converter

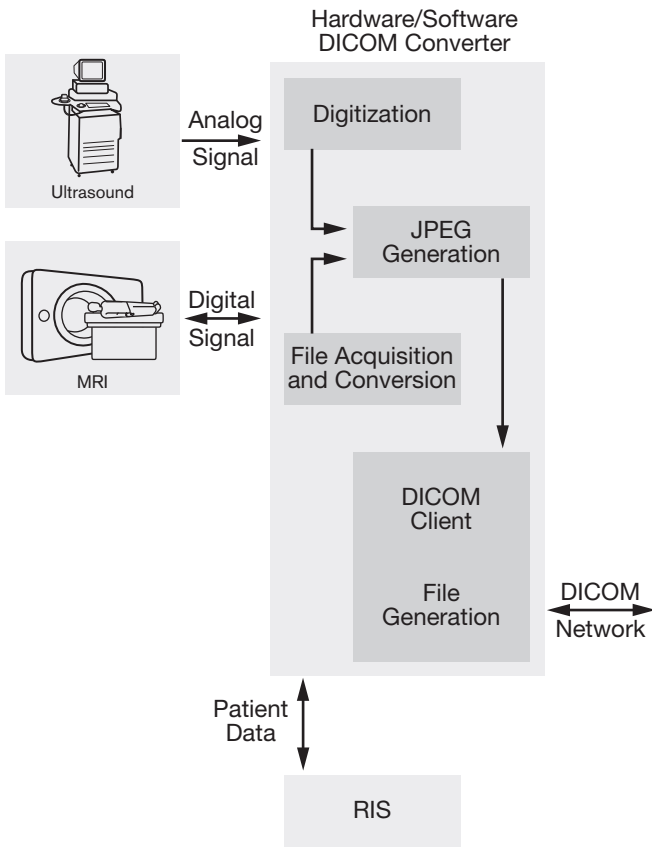

Figure 3

Latin America have invested in relatively new equipment that is non-DICOM compliant, but it cannot be discarded. In some cases, the equipment can be upgraded into a DICOM system, but often this cannot be done. In such cases a HW/SW interface is required to take the source image, convert it into a JPEG format and compress the file. If the hospital has a radiology information system (RIS), the interface will request all the patient information attached to the image in order to generate a complete DICOM file. In this way, non-DICOM equipment can be interconnected to a DICOM network at 20 percent of the cost of a new DICOM-compliant instrument.

Figure 3 illustrates the general principle of the HW/SW DICOM converter.

Converters already in the market are interfaces that need to be permanently installed to provide service to one modality. The challenge is to design a low-cost converter capable of providing service to more than one piece of equipment at a time by sharing the interface. It must also be capable of connecting both new portable devices and legacy portable equipment into the DICOM network.

Figure 4 illustrates a portable ultrasound unit based on a Freescale ColdFire® MCF520x microprocessor.

Most of the specialized equipment used at hospitals is compatible with the DICOM standard. Now is the time to convert portable and home health care devices to the same standard, either through newly designed equipment or HW/SW converters that can connect older devices to the network.

## DICOM-Compliant Portable Ultrasound Unit

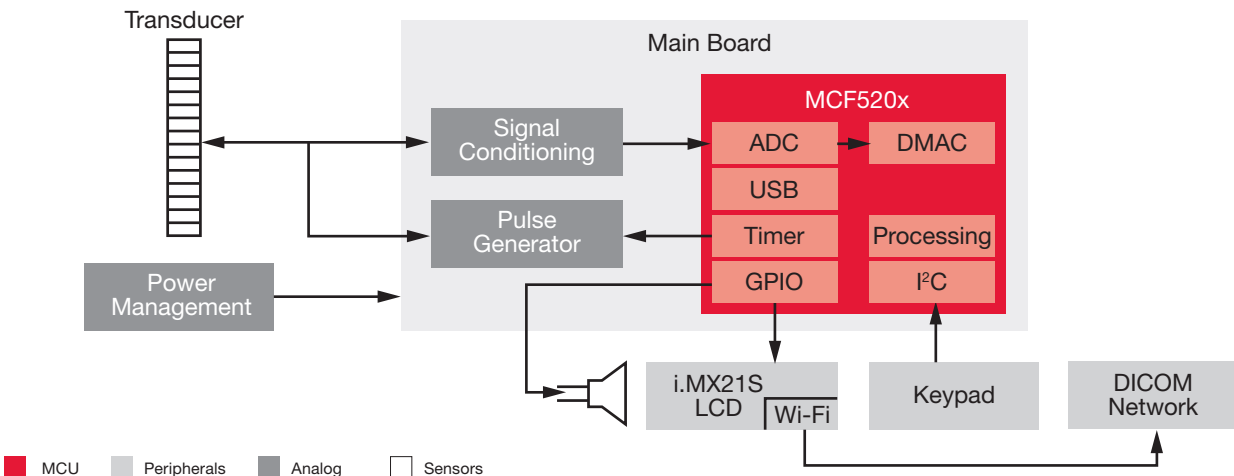

Figure 4

Rodolfo Gonzalez joined Freescale in 2006 as a hardware design engineer. Previously, while at the National Institute of Astrophysics Optic and Electronic, INAOE, he designed DICOM interfaces for radiology equipment as well as a data acquisition device for an electronic navigation system. In addition, Gonzalez developed several projects for the Mexican Army.

Leonardo Mangiapelo

## Implementing an Electrogoniometer Using Freescale's low g accelerometers

### Introduction

Rehabilitation engineering is the systematic application of engineering sciences to design, develop, adapt, test, evaluate, apply and distribute technological solutions to problems confronted by individuals with disabilities. Determining precise joint angles is extremely important to rehabilitation and biomedical engineers as well as physiotherapists and ergonomics specialists. The angle data is essential for identifying abnormal patterns and characterizing impairments, disabilities and handicaps. Disabled patients, such as those suffering from hemiplegia (half the body is paralyzed) or hemiparesis (half the body is weakened but not paralyzed), may experience limited speed and amplitude in some body movements. For such cases, an electrogoniometer is a useful tool for measuring joint angles, such as those for elbows or knees, to determine the extent of the disability. The electrogoniometer is an electronic device that uses angle sensors, such as potentiometers, strain gauges and, more recently, accelerometers to record such measurements.

### Commonly-used technology

The most common electrogoniometers employ one of the following three sensor schemes:

#### Potentiometric Electrogoniometer

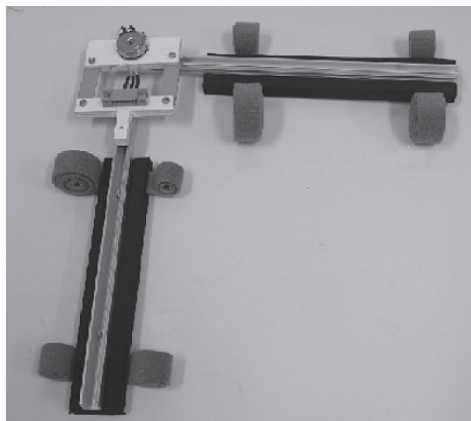

Figure 1

**Potentiometers:** A potentiometric element is attached to a joint's rotation point. The potentiometer's electrical resistance can be used to determine the angle between the joints. These types of electrogoniometers are somewhat bulky and restrict patient movement. The instrument's precision can also be compromised due to its inability to follow any changes in the joint's axis of rotation.

#### Flexible Electrogoniometer

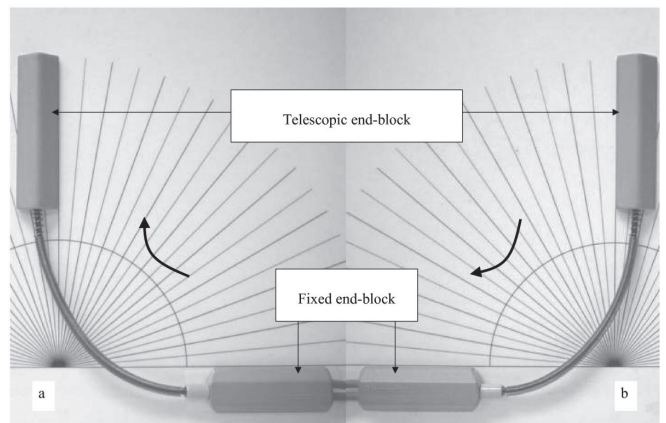

Figure 2

**Strain gauges:** Also known as flexible electrogoniometers, a strain gauge is a flexible spring with plastic end blocks on each end. The strain gauge mechanism is housed inside the spring, which changes its electrical resistance proportionally to the change in angle between the plastic end blocks' longitudinal axes. Strain gauges are lightweight, portable, easily applied, do not restrict movements nor interfere in patient activities and adapt well to different body segments. These are currently the most popular electrogoniometers.

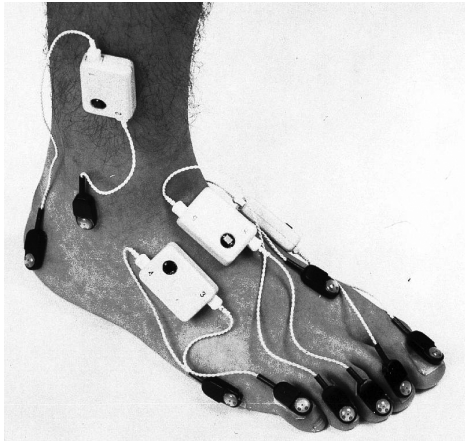

Figure 3

Optoelectronic systems: These are video systems that use one or more video cameras to track bright markers placed at various locations on the patient's body. These markers are either infrared (IR), light emitting diodes (LEDs) or solid shapes of reflective tape. The system keeps track of the vertical and horizontal coordinates of each marker, and computer software processes this information to determine the angle on the body segments of interest. Although optoelectronic systems offer good precision, their calibration procedures and data analysis are time-consuming.

Accelerometer Behavior

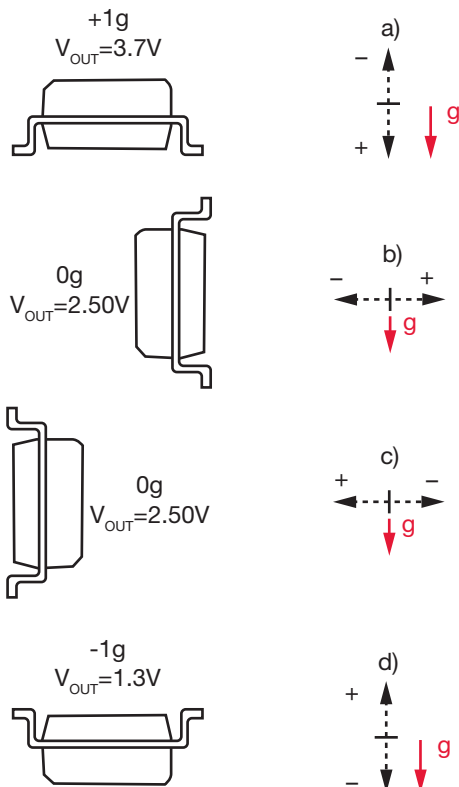

Figure 4

## Using accelerometers to measure angles

For electrogoniometer applications, Freescale offers a wide variety of accelerometers that offer the following features:

- Low g, medium g and high g, ranging from 1.5 to 12g measurement capability
- One, two or three axis measurements, allowing greater application flexibility
- Either analog or digital (I<sup>2</sup>C/SPI) output signal format
- Fast response time, low current consumption, low voltage operation and a standby mode, all in a small profile package to detect fall, tilt, motion, positioning, shock or vibration

The Freescale MMA1260 (Z-sensing axis) low g accelerometer is a good choice and behaves as illustrated in Figure 4.

Comparing Figures 4 and 5, when the accelerometer is in a static horizontal position, or zero degrees angle (a), its horizontal axis is exposed to the earth's gravity acceleration, registering a positive 1g, and the analog output voltage is at its maximum value. If it rotates 90 degrees in either negative (b) or positive (c) directions, the acceleration on its axis will be 0g, and the analog output value will be in its intermediate range value. If it rotates 180 degrees (d), negative gravity acceleration will register -1g, and its output analog signal will be at its minimum value.

By using this behavior and simple linearization techniques, a simple 8-bit microcontroller (MCU), such as Freescale's MC9S08JM (S08JM) device with USB functionality, can be used with an accelerometer to measure one-dimension angles between any surface and the horizontal plane. In this case, an analog-to-digital controller (ADC) channel was used to convert the analog signal and process it as digital angle information. However, the need for an ADC is eliminated if an accelerometer with I<sup>2</sup>C or SPI output is used instead. Furthermore, this method can be extended to measure angles in two and three dimensions using Freescale's MMA7455L 3-axis digital output accelerometer, for example. By doing this, instead of measuring the relative angle between two segments, it's possible to create a three-dimensional representation of the segment being measured, allowing more information to be gathered.



## Graphical Behavior of the Analog Output Voltage vs. the Angle with the Horizontal Plane

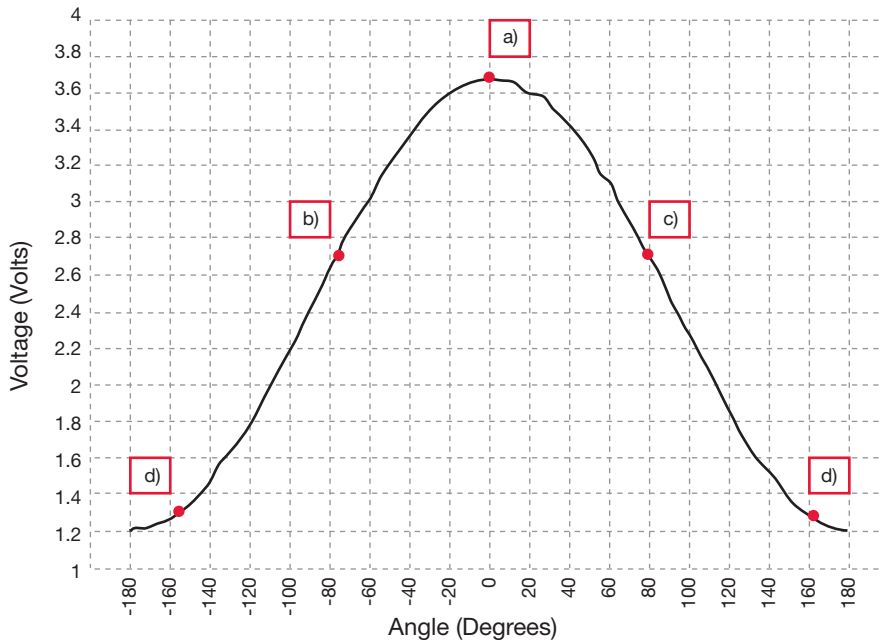

Figure 5

### MCUs in the HCS08JM Family

| Features           | MC9S08JM8                | MC9S08JM16               | MC9S08JM32                       | MC9S08JM60                       |
|--------------------|--------------------------|--------------------------|----------------------------------|----------------------------------|
| Core               | HCS08 Core               | HCS08 Core               | HCS08 Core                       | HCS08 Core                       |
| Flash (KB)         | 8                        | 16                       | 32                               | 60                               |
| RAM (KB)           | 1                        | 1                        | 2                                | 4                                |
| USB RAM (Byte)     | 256                      | 256                      | 256                              | 256                              |
| KBI                | Up to 7                  | Up to 7                  | Up to 8                          | Up to 8                          |
| ADC                | Up to 8-ch., 12-bits     | Up to 8-ch., 12-bits     | Up to 12-ch., 12-bits            | Up to 12-ch., 12-bits            |
| SCI                | 2                        | 2                        | 2                                | 2                                |
| I <sup>2</sup> C   | Yes                      | Yes                      | Yes                              | Yes                              |
| Full-Speed USB 2.0 | Device                   | Device                   | Device                           | Device                           |
| Package            | 48 QFN, 44 LQFP, 32 LQFP | 48 QFN, 44 LQFP, 32 LQFP | 64 QFP, 64 LQFP, 48 QFN, 44 LQFP | 64 QFP, 64 LQFP, 48 QFN, 44 LQFP |

Table 1

## S08JM family of MCUs

The S08JM family, which is part of the low-cost, high-performance HCS08 family of 8-bit MCUs, extends Freescale's entry-level USB portfolio with one of the industry's most cost-effective USB control solutions. Featuring on-chip USB 2.0 full-speed device support, the S08JM family provides an economical, quick and easy way to standardize serial communications in industrial and consumer applications. All MCUs in the family use the enhanced HCS08 core and are available with a variety of modules, memory sizes, memory types and package types. The S08JM8 MCU is a good, cost-effective choice for this application because it has all the peripherals necessary to implement electrogoniometer functionality. These include ADC, I<sup>2</sup>C/SPI and USB communications. More information about this and other 8-bit MCUs can be found at [www.freescale.com/8bit](http://www.freescale.com/8bit).

## Implementation

Figure 6 is a prototype of an accelerometer-enabled electrogoniometer. Essentially, the prototype was constructed on a platform (A) to study the accelerometer's (B) angle behavior using segments controlled by stepper motors (C) and a microcontrolled circuit. The joint angle is simulated by the stepper motors controlling the movement of the segments connected to the accelerometers' axes. These accelerometers (MMA1260) send the electrogoniometer (D) an analog signal proportional to the angle of each segment.

The electrogoniometer then converts the analog signals to digital signals using simple ADC conversions and extracts angle information by using simple linearization techniques. This information is then sent to a computer and an LCD display via USB communication.

## Accelerometer-Enabled Electrogoniometer Prototype

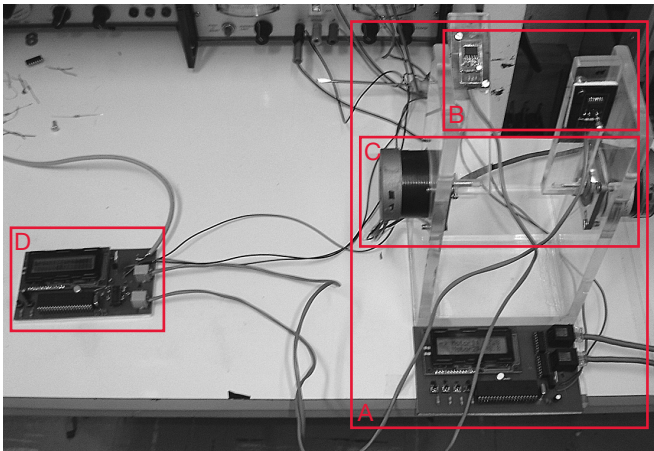

Figure 6

- A) Angle measurement platform
- B) Accelerometers
- C) Stepper Motors
- D) Electrogoniometer

A block diagram of the system (Figure 7) illustrates the use of Freescale's low g accelerometers as the angle sensors, sending the angle of each segment to the central processing unit via analog or digital serial communication, depending on the accelerometer used. The central processing unit, an S08JM MCU which acquires the angles from the accelerometers,

## Block Diagram of the Implemented Electrogoniometer

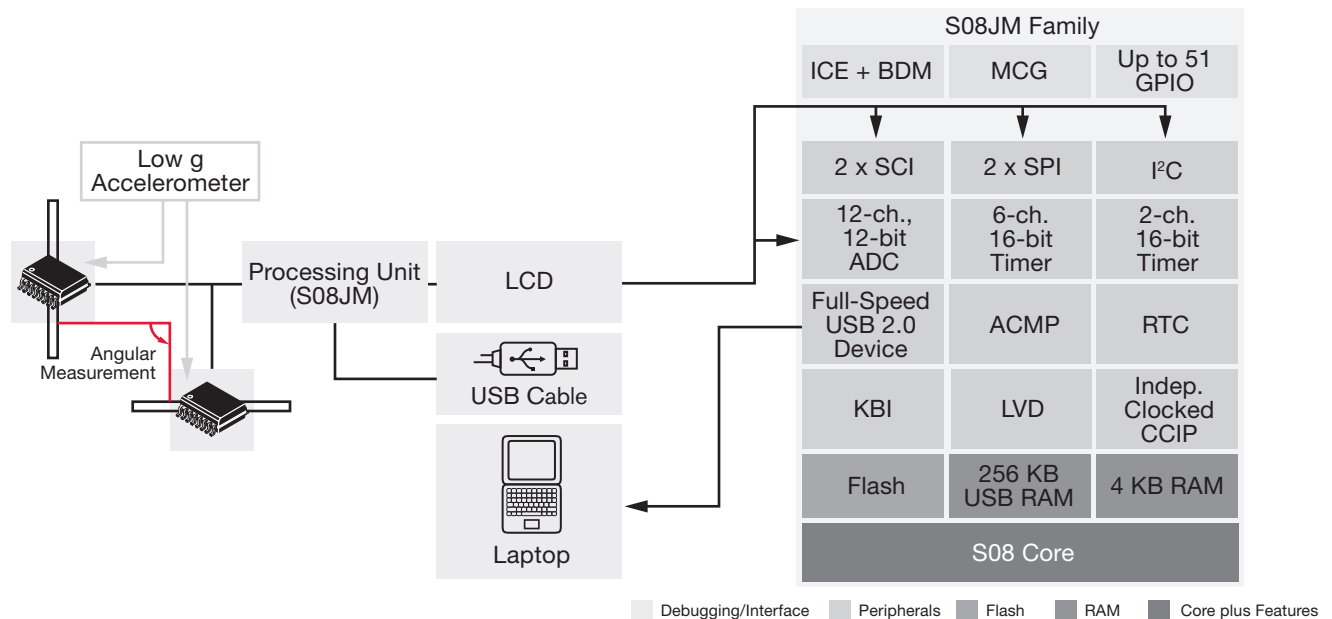

Figure 7

Leonardo B. S. Mangiapelo received a bachelor's degree in electrical engineering at the Universidade Estadual Paulista, UNESP, Ilha Solteira in July 2007. He has worked in the industrial automation industry throughout Brazil. He joined Freescale in May 2008 through the Ministry of Science and Technology program to work on the SASD team as a digital verification engineer.

makes all necessary calculations and sends this information to an LCD. USB communication can also be used to send the data to a printer or to be stored for further clinical analysis.

## Conclusions

Using the methodology and techniques described in this article, it is possible to implement precise, low-cost angle measurement systems for electrogoniometers or other applications used to measure static angles. The article focuses on how to implement single-axis measurements, but the same methodology can be used for two- and three-axis measurements. Multiple-axis measurements using Freescale's accelerometers can provide the data necessary for a complete three-dimensional representation of any segment.

It is important to note that this method is very useful for all static angle measurements for such clinical cases as hemiplegia or hemiparesis, where patients present movement limitations. In these cases, the electrogoniometer is very useful for measuring, monitoring and recording patient performance and treatment results. The method, however, is not recommended for many sports medicine cases where high-speed body movements may induce measurement errors for all acceleration forces other than earth's gravity. Nonetheless, for clinical measurement studies of movement impaired patients, accelerometer-enabled electrogoniometers are highly efficient, cost-effective monitoring tools.

Thomas Böhm

# A Matter of Torque

## Electric power steering system

Electric power steering offers greater vehicle safety by adapting variable steering ratios to human needs, filtering drivetrain influences and even adjusting active steering torque in critical situations. In addition, it can make cars lighter and more fuel efficient when compared to those using hydraulic steering systems.

The central electronic elements of today's power steering systems are modern 32-bit microcontrollers (MCUs). Only high-performance MCUs can provide sufficient computing power and specialized peripherals for complex motor control functions. Since power steering is a safety-critical function, it also requires new MCU elements that support the functional safety of the overall system.

This article provides an overview of the latest generation of Power Architecture® based MCUs and describes how they are used in power steering applications. New innovative elements, such as the cross-triggering unit for motor control and the fault collection unit for monitoring and reporting safety critical signals, are explained.

### Introduction

During the last decade, advanced chassis control functions have become main technology drivers for active safety systems in vehicles, and electric power steering (EPS) nicely combines vehicle safety with higher fuel efficiency. With the first systems entering the market in the mid 1990s, purely electronic steering systems have migrated to almost every segment of the vehicle market.

EPS in modern cars can significantly reduce fuel consumption when compared to cars using hydraulic solutions. Industry studies have shown that EPS can save up to 85 percent of the energy normally needed to steer a vehicle with conventional hydraulic systems. The result is fuel consumption reductions of up to 0.3 liters per 100 kilometers driven. EPS is so efficient because the system is only activated when steering support is really needed. As a result, a permanent engine load is not required.

EPS systems also can help ensure safer driving. The steering torque is adapted to the vehicle's speed and optimized for different driving situations. For example, during low-speed driving maneuvers, such as parking, EPS provides a higher level of assistance than it does at higher speeds, when electronic power assist is gradually reduced to enable more direct steering and better feedback from the road.

By integrating sensors and network connectivity, EPS can further enhance its safety characteristics through improved dynamic control and warning functions:

- Improved vehicle dynamics control
  - Helping and guiding the driver with additional steering torque in over-steer situations
  - Reducing stopping distance by coordinating with the electronic stability control (ESC) system on roadways with differing friction levels
- Warning functions
  - Generating a slight counter-steering torque in order to prevent the vehicle from unintentionally drifting out of its lane

### System overview

Depending on the level of assisting forces required, various types of EPS systems exist. The different architectures include:

- Column-drive systems
  - Typical for relatively light vehicles with lower steering forces
  - DC or BLDC EPS motor integrated with the steering column
- Rack-drive systems
  - Typical for larger vehicles requiring high steering forces
  - Assist power is directly applied to the steering rack with a BLDC EPS motor

The elements that all EPS architectures have in common are a steering wheel with integrated steering angle sensor, a steering torque sensor, a power steering control module and a motor for generating the required assist force.

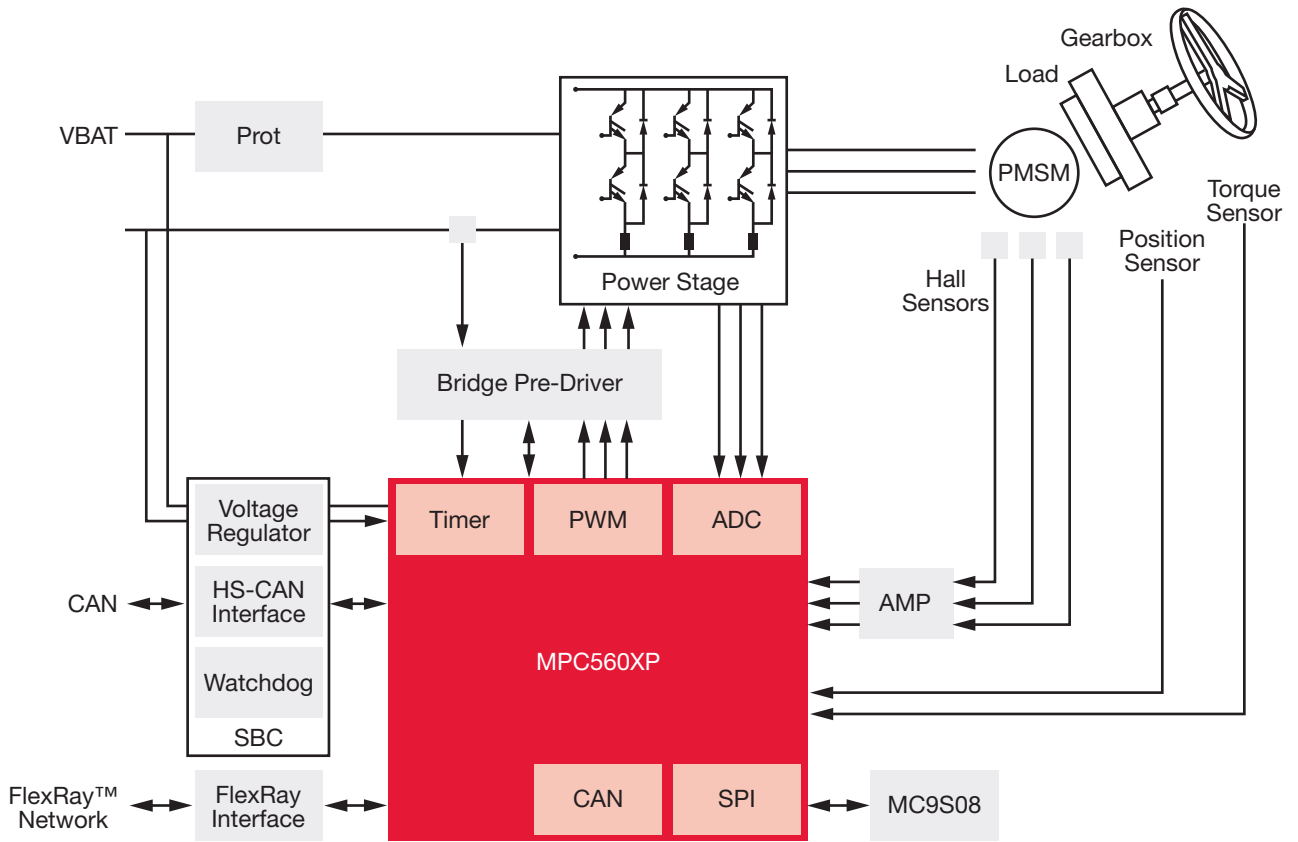

Figure 1

Permanent magnet synchronous motors (PMSM) with their improved efficiency and higher reliability are now widely used in electric power steering systems. Minimizing the non-linearity in the motor torque characteristic while generating the maximum torque requires a sophisticated motor control approach called vector control, which requires real-time processing for the stator phase currents and rotor position.

Figure 1 illustrates the basic architecture of a power steering control module, and its main functions:

- Generating and monitoring the component supply voltages
- Monitoring/preprocessing steering torque and steering angle sensor signals
- Receiving vehicle speed and engine speed signals via CAN or FlexRay™ protocols
- Receiving control inputs from other systems, such as the braking controller
- Calculating the necessary assisting force/torque
- Motor signal processing and torque vector control
- PWM signal conditioning and controlling the MOSFETs typically used in 3-phase motor drives for power steering

The Freescale MPC560xP family of Power Architecture-based MCUs is specifically designed for advanced motor control applications. It provides all high-precision analog-to-digital converter (ADC) and timer functions required for motor signal acquisition, a powerful Harvard architecture core and flexible PWM modules that allow center, edge-aligned and asymmetric PWM duty cycles.

The new MC33905 family of system basis chips consists of integrated power management solutions for 32-bit MCUs and other components of a power steering control unit. The devices combine dual 5V/3.3V selectable voltage regulators with an ISO11898 high-speed CAN interface and up to two LIN 2.0 interfaces. Integrated monitors guarantee undervoltage detection as well as voltage, current and temperature protection.

The MC33937 pre-driver integrates high side and low side FET drivers with greater than 1A gate drive capability. The device can be directly interfaced to the microcontroller's PWM outputs and is configurable via an SPI port.

## Typical Power Steering Motor Control Cycle

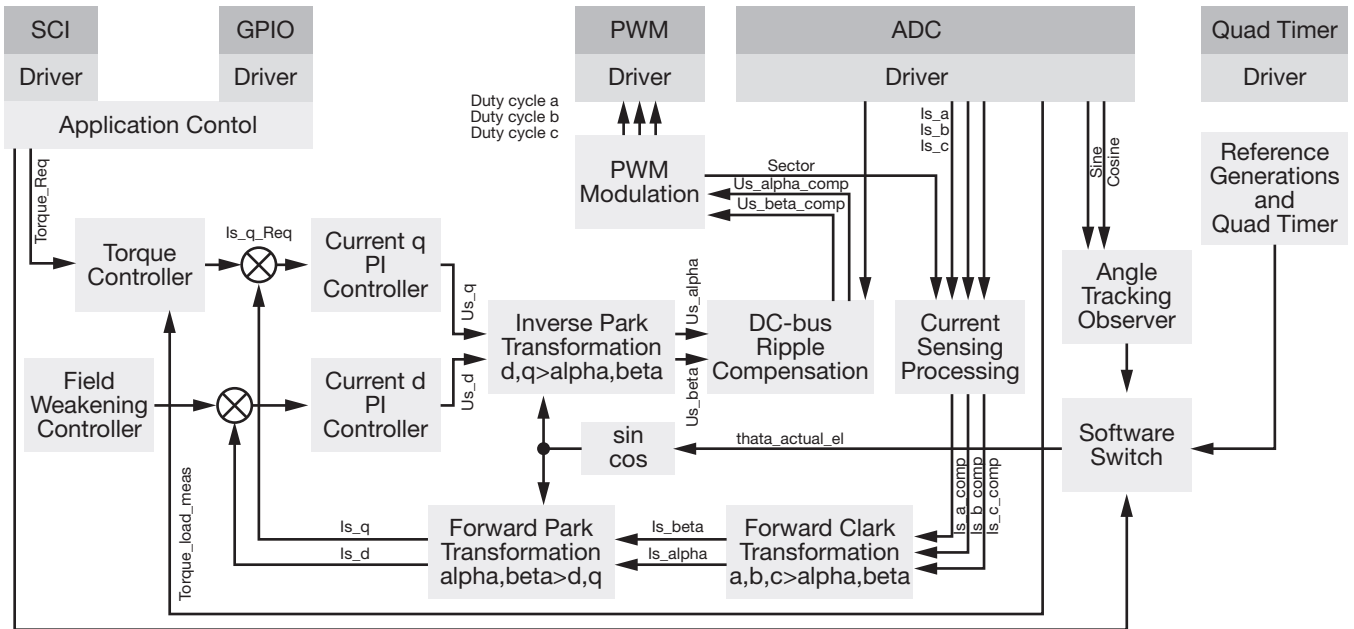

Figure 2

## Technical challenges

Vector control seeks to align the PMSM's rotor and stator fields in a way that delivers maximum torque. The optimum solution is when both fields are oriented 90 degrees from each other. The control scheme designed to keep the 90 degree field alignment is often referred to as field oriented control (FOC).

The typical cycle time for a PMSM control scheme is about 50  $\mu$ s, during which the following tasks will normally need to be performed:

- Motor phase currents and DC bus current measurements and calculations
- Encoder/resolver signal processing and rotor position calculation
- Motor current processing (id, iq) via Clark/Park transformation
- Processing current control algorithms
- Generating new PWM signals via reverse Park/Clark transformation

Due to the tasks outlined above and the functional safety system requirements, electric power steering control unit designers will face the following technical challenges.

### Fast and precise acquisition of state variables

Given the PWM control cycle time, a fast and precise ADC is needed to acquire the DC bus current and/or phase currents. The ADC needs to provide high conversion speed in order to allow for oversampling of multiple data points within a single PWM cycle. A typical requirement is  $\leq 1.5 \mu$ s conversion time with at least nine bits.

### Real-time control code processing

In order to derive new PWM control values for the motor, the measured/calculated phase currents have to be transformed into direct and quadrature components of a rotating reference frame. The advantage of this transformation is that current components have DC steady-state values now, which allows relatively simple PI-Type control algorithms for error compensation. Resulting control signals are transformed back to 3-phase quantities and applied to the motor via PWM outputs. Figure 2 shows a typical example of such a control cycle.

### Synchronizing A/D conversion, timer inputs and PWM

In a control scheme as described above, it is important to schedule the acquisition of the state variables, such as currents or position counter information, with respect to the PWM cycle. With traditional MCU peripherals, complex schedules require substantial central processing unit (CPU) involvement. Examples include ADC configuration and adapt handling or pre-setting the timer and PWM registers for the next control cycle.

### Compliance with functional safety standards

An EPS system is a safety-critical element that needs to meet the requirements of industry standards, such as IEC61508 or ISO26262. State-of-the-art functional safety concepts for power steering control units require sophisticated fault monitoring of MCU functions in order to allow the system to enter a safe state in case of malfunction. Collecting internal faults and reporting these to an external circuitry, even if the CPU is malfunctioning, is a typical technical requirement for power steering controller solutions.



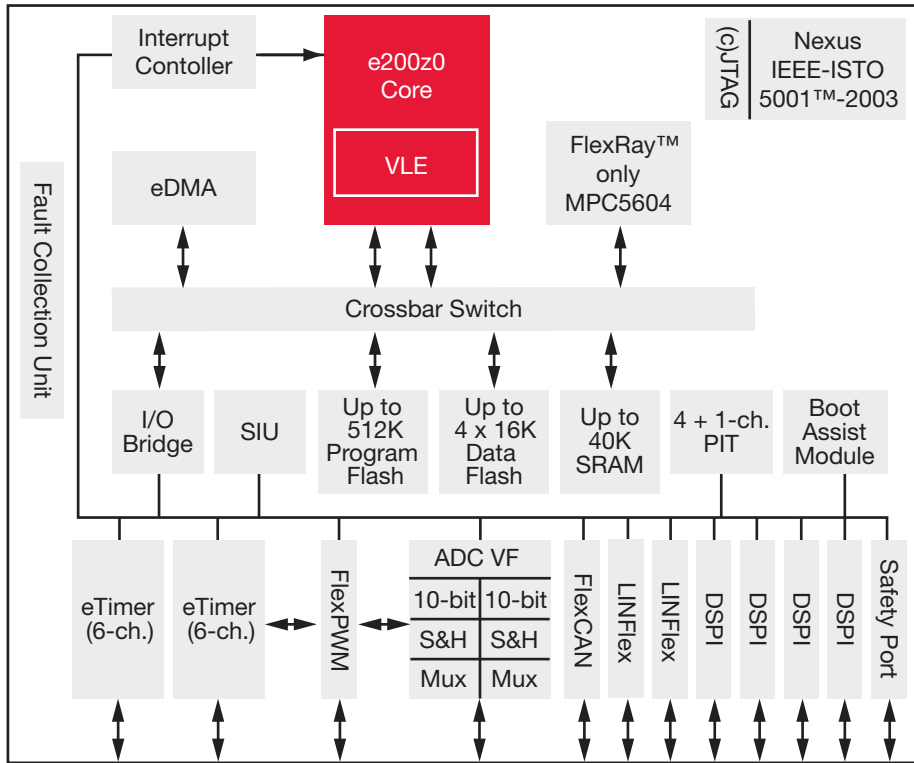

Figure 3

## MPC560xP controller family for motor control

Freescale's new MPC560xP family of 32-bit MCUs, with a Harvard-type Power Architecture core and a set of powerful motor control peripherals, provides an ideal solution for EPS and other advanced motor control applications.

Features include:

- High-performance 64 MHz 32-bit e200z0 Power Architecture CPU with variable length encoding (VLE) for code compression
- Up to 512 KB on-chip flash memory with ECC, additional 4 x 16 KB on-chip data flash memory with ECC for system configuration data storage and fault events
- Up to 40 KB on-chip RAM with ECC protection
- One 16-channel enhanced direct memory access (eDMA) controller
- Two general purpose eTimer modules, each with six timers, 16-bit resolution cascadable counters and quadrature signal decoding
- One 16-bit resolution PWM module with configurable dead-time insertion and fault inputs
- Two 10-bit ADCs supporting simultaneous conversions in less than 1  $\mu$ s with a linearity error of  $\pm 1$  LSB

- Cross triggering unit that allows automatic generation of ADC conversion requests during the PWM period without CPU load and dynamic configuration optimization via DMA
- Four serial peripheral interface modules for communication with MC33905 system basis chips, MC33937 pre-drivers and other control unit components
- Two serial communication interface modules with LIN support
- Up to two CAN modules with 32 message buffers
- One dual-channel FlexRay controller with 32 message buffers for safe communication with other control units
- Fault collection unit for collecting internal controller faults and reporting these to an external circuitry, even in the case of a malfunctioning CPU
- Safety elements, such as a programmable watchdog timer, redundant 16 MHz internal RC oscillator, junction temperature sensor and a non-maskable interrupt
- On-chip single-supply voltage regulator supporting 3.3V and 5V

In order to guarantee optimal peripheral performance as well as highest timer and PWM resolution, all motor control related modules can be configured to use a dedicated clock domain supporting up to 120 MHz. All other peripherals use the 64 MHz main system clock.

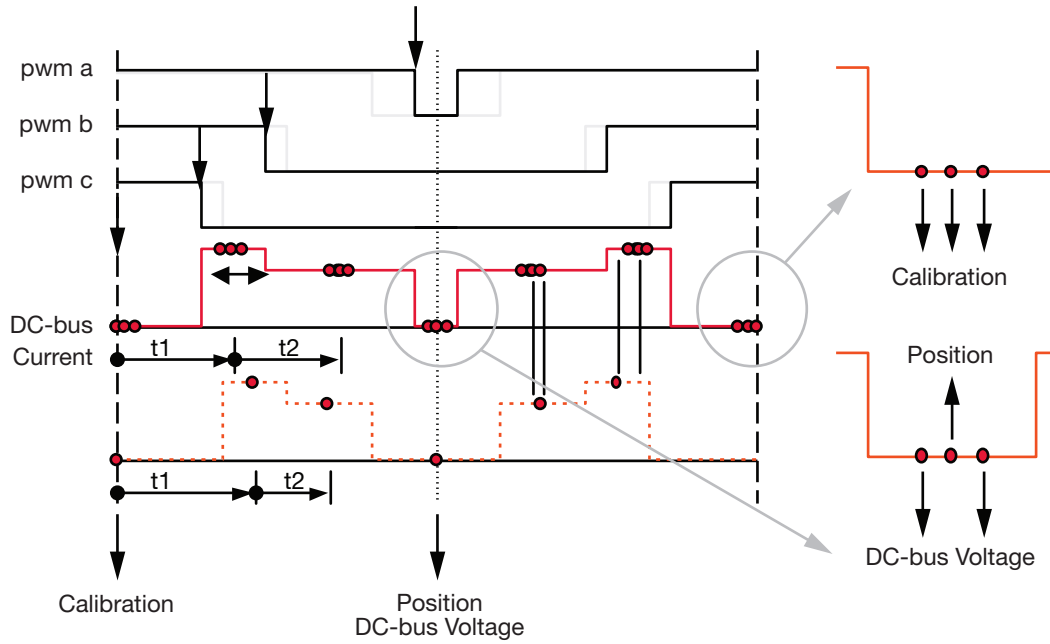

Figure 4

## State variable acquisition: scheduling problems

As discussed before, scheduling state variable acquisition with respect to the PWM cycle is technically challenging and often results in a significant interrupt load for MCU. In order to completely avoid CPU involvement in the acquisition of key state variables, a new hardware element, the cross triggering unit (CTU), was introduced on the MPC560xP family.

The CTU receives inputs from internal controller sources, such as the PWM module and timers, but also allows an external trigger from a GPIO port. Inputs can be on the rising edges, falling edges or both edges of each received signal. A trigger generator handles incoming signals in terms of input selection, active edges definition and master reload signal generation. On the basis of incoming signals, the trigger generator can generate up to eight trigger events. Two modes are supported:

- Triggered mode: each source of the incoming signal can generate up to eight trigger event outputs
- Sequential mode: each source of the incoming signals can generate one trigger event output only

Depending on the trigger events generated, a scheduler unit generates specific outputs, including:

- Command or stream of commands for the ADC
- Pulse for the timer module
- External trigger pulse via GPIO

## Example: A/D conversion

In order to avoid any CPU intervention, the ADC module must be controlled by the CTU. This requires the ADC to be switched to CTU control mode, which allows the scheduler unit to send ADC commands when a trigger event occurs. As an alternative to conventional results registers, ADC results can be stored in one of four FIFOs. These FIFOs allow conversion results to be dispatched according to the type of acquisition (i.e., phase currents, rotor position, ground noise).

Further minimizing CPU load, the CTU is fully DMA supported. The master reload signal provided by the trigger generator can be used as a DMA request, for example. DMA transfers are also used to read data from the result FIFOs.

All CTU registers are double buffered, which allows setting a new configuration while actual acquisitions are made. Figure 4 is an example of a triggered sequence of A/D conversion that can be implemented very efficiently using the new CTU.

## Functional safety: fault collection

Another innovation introduced with the MPC560xP family is the fault collection unit (FCU). This hardware module is intended to simplify controller-level fault reporting in safety-critical applications. The FCU can handle up to 32 controller internal fault signals, such as loss of system clock, loss of PLL lock or multi-bit ECC failures. The module allows the user to select how different fault signals will be treated. Three options can be configured:

- No Action: no specific counter measures needed to manage the fault
- Alarm: allows software and/or hardware to recover from the fault
- Fault: direct communication to external circuitry via two dedicated GPIO pins

Three different protocols can be used to communicate with external circuitry. The dual-rail scheme is one example of a supported protocol. As long as no critical fault occurs, the FCU output pins will toggle between (0,1) and (1,0) with a configurable frequency. By default, this value is  $f=976 \text{ Hz}@64 \text{ MHz}$ . If a fault is detected, these pins will toggle between (0,0) and (1,1) at the same frequency, which would allow external circuitry to bring the system into a safe state.

In order to guarantee CTU independence in case other controller modules or the main core malfunction, the module runs on a separate internal 16 MHz RC clock. This allows deterministic computation of output signals and time outs. Additional safety elements, such as a programmable watchdog timer, a junction temperature sensor and FlexRay support, complete the list of controller features that support IEC61508 or ISO26262 certifiable systems design.

## Summary

The Freescale MPC560xP family of Power Architecture controllers provides an optimal solution for advanced automotive motor control applications, such as EPS. Such technical challenges as timed acquisition of state variables are resolved with a new cross triggering unit that allows significantly reduced interrupt load due to hardware synchronization of the PWM cycle, timers and the ADCs.

The fault collection unit, a new hardware element, supports power steering system certification according to such safety standards as IEC61508 and ISO26262. The FCU is intended to ease controller-level fault reporting in safety-critical applications and completes the set of safety features available on the MPC560xP controller family. This family, in combination with MC33937 pre-drivers and MC3390x system basis chip solutions that integrate power supply, network interfaces and signal monitoring capabilities, provides the main building block for state-of-the-art EPS systems.

Based in Munich, Germany, Thomas Böhm is global marketing manager for chassis, safety and driver assistance solutions for Freescale Semiconductor. He joined Freescale in 2000 as a system engineer and has worked in several business development positions since 2004. He earned a degree in electrical engineering from Chemnitz University of Technology and received an MBA from OUBS in the United Kingdom.

Oziel Hernandez, Varun Jain, Suhas Chakravarty and Prashant Bhargava

# Position Location Monitoring

## Using IEEE<sup>®</sup> 802.15.4/ZigBee<sup>®</sup> technology

### Freescale and ZigBee<sup>®</sup> technology can help you locate your kids

In this article you will learn how Freescale and ZigBee technology can help you implement a low-cost, low-power location monitoring system for indoor environments where other positioning systems have typically performed poorly. This article is a useful tool to help system designers understand the very basic concepts of cooperative localization.

### Location monitoring without GPS? How does it work?

Believe it or not, it is possible to locate people or other objects in an indoor environment without using expensive global positioning system (GPS) devices. What's more, GPS performance inside buildings is very limited due to impaired line of sight (LOS) to the GPS satellites.

A location monitoring system can be developed with moderate performance with a ZigBee mesh network that uses low-cost IEEE 802.15.4 embedded devices. At this point, however, it is important to clarify what ZigBee technology and IEEE 802.15.4 are because sometimes they are erroneously used interchangeably.

IEEE 802.15.4 is a wireless standard that defines the physical (PHY) and medium access control (MAC) layers while ZigBee technology adds network (NWK) and application (APL) layer specifications on top of 802.15.4 to complete what is called the full ZigBee stack. For the scope of this article we are proposing ZigBee-compliant devices because the mesh networking capability is implemented in the NWK layer.

In Figure 1, we have a ZigBee mesh network where each device can communicate directly or through neighbor devices with other devices in the network. Connections between nodes are dynamically updated and optimized in difficult conditions. Mesh networks are decentralized where each node is self-routing and able to connect to other nodes as needed. The characteristics of mesh topology, thanks to the Ad hoc On Demand Distance

#### ZigBee<sup>®</sup> Mesh Network

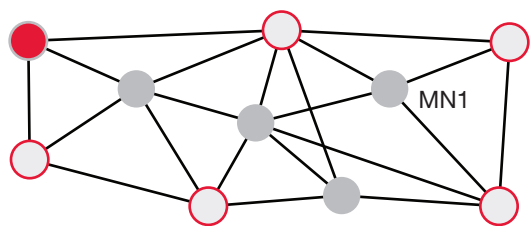

□ Static Nodes    ■ Gateway Nodes    ■ Mobile Nodes

Figure 1

Vector (AODV) routing protocol, provide greater stability in changing conditions (self-forming) or when single nodes fail (self-healing). In our ZigBee mesh network in Figure 1, we have three different types of nodes, all of them working on the same IEEE 802.15.4 physical link.

The gateway node (GN) is used to connect or interface our ZigBee network to an external computer or computer network (Figure 2). It is always wall-powered and non-mobile with significant computational power. These nodes are usually called ZigBee coordinators (ZC).

#### Example Board Setup for Gateway Node

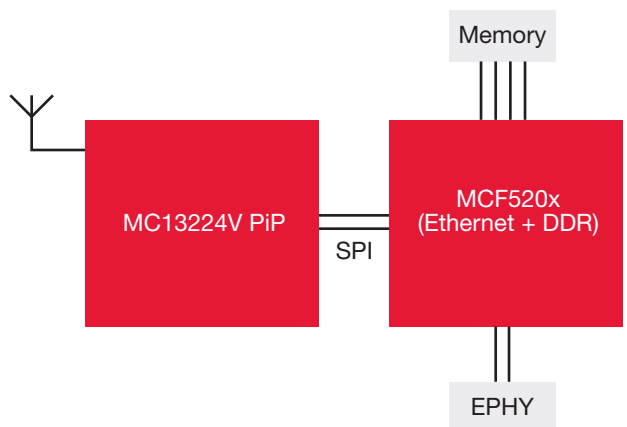

Figure 2

The static nodes (SN) are normally wall-powered and in a fixed known location (non-mobile) because they will act as references for the rest of the nodes that we want to locate (Figure 3). They too have higher computational power. SNs have a similar function to that of the satellites in a GPS system. These nodes are called ZigBee routers (ZR).

### Example Board Setup for Static Node

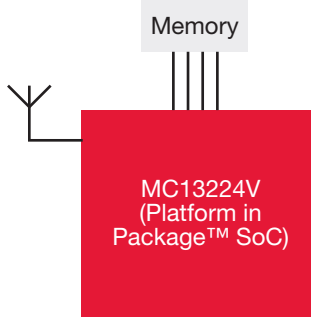

Figure 3

Finally, we have the mobile nodes (MN), which need to be battery-powered and as small as possible with lower computational capabilities (Figure 4). This is because they do not store network-wide information nor do they need to be able to perform network-related services. If you want to locate people inside a building, MNs can be worn as badges, bracelets or other form of accessory. In the case of a badge or ID application, these might even support memory cards to store information programmed by the user or an LCD display for easy human interfacing. An MN can either be a ZR or ZigBee end device (ZED).

### Example Board Setup for Mobile Node

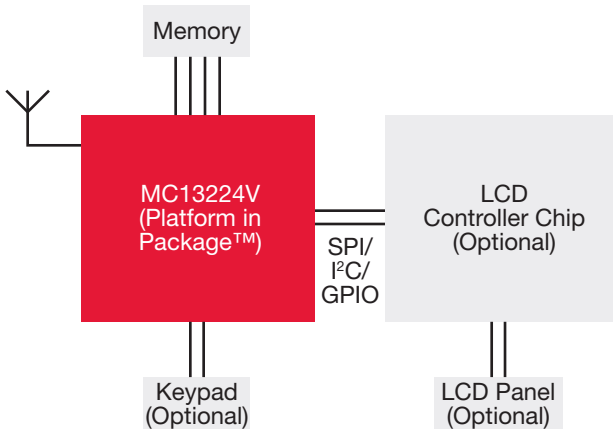

Figure 4

A keypad or LCD panel would be optional, for instance, when the MN is used as a tag to locate inventory in a hospital or school. (See the Position Location Application section for more details).

The SNs should be strategically located throughout the area to provide coverage for our position monitoring system. The more SNs the system has, the better it will perform.

Now we have all the pieces in place, but how does this low-cost, low-power, low-complexity local positioning system work? Let's go back to Figure 1. Imagine that mobile node 1 (MN1) needs to be located. You can see MN1 is in the vicinity (within its transmission radius) of three static nodes, so it is able to estimate its position using a multilateration technique, which can be based on range measurements taken using received signal strength indicator (RSSI) or by measuring the angle of arrival (AOA). AOA implies the use of multiple antennas, so that's why using range measurement based on RSSI is simpler and lower cost.

For ZigBee-based position monitoring systems it is important to have enough coverage for device triangulation. Remember, we need to get at least three distances from the SNs to the node we want to locate<sup>[9]</sup>. But what happens when an MN does not have a direct connection to an SN node?

Typical Wi-Fi-based location monitoring systems assume that a direct connection between the MN we want to locate and at least three reference nodes can be established at any time. In Figure 1 our ZigBee network shows that every MN has a direct connection to at least three SNs.

On the other hand, in Figure 5 shown below you can see another ZigBee mesh network where MN2 and MN3 only have a direct connection with two SNs. However, in this case, it is still possible to locate the two MNs because ZigBee technology offers a multihop routing capability. In other words, MN2 may establish a communication with and calculate the distance to the SN above MN3 using MN3 as an intermediate hop. It is important to highlight that in this case MN3 must be a node with ZR capabilities.

### Another ZigBee® Mesh Network

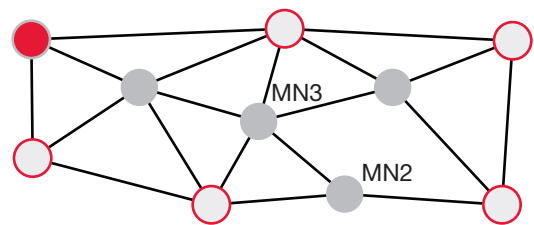

□ Static Nodes    ■ Gateway Nodes    ■ Mobile Nodes

Figure 5

Multihop position monitoring is a very important ZigBee capability.



## Wireless Technologies Comparison (ZigBee, Bluetooth, UWB, and Wi-Fi)

|                        | ZigBee®                 | Bluetooth®                | UWB™                            | Wi-Fi                                   |
|------------------------|-------------------------|---------------------------|---------------------------------|---|
| Standard               | IEEE® 802.15.4          | IEEE 802.15.1             | IEEE 802.15.3a (to be ratified) | IEEE 802.11 a, b, g (n, to be ratified) |
| Industry organizations | ZigBee Alliance         | Bluetooth SIG             | UWB Forum and WiMedia™ Alliance | Wi-Fi Alliance                          |
| Network topology       | All                     | Star                      | Star                            | Medium dependent                        |
| Data rate              | 250 Kbps                | 723 Kbps                  | 110 Mbps–1.6 Gbps               | 10–105 Mbps                             |
| Range                  | 10–300m                 | 10m                       | 4–20m                           | 10–100m                                 |
| Power                  | Very low                | Low                       | Low                             | High                                    |
| Battery life           | Alkaline (Months–Years) | Rechargeable (Hours–Days) | Rechargeable (Hours)            | N/A                                     |
| Max. nodes             | 65,000                  | 8                         | 128                             | 32                                      |

Table 1

IEEE 802.15.4 radios provide very good “free-space” ranges up to 300 meters, which can be used to extend the coverage of the positioning system. For indoor applications, range drops to about 25–75 meters depending on building layout, contents and construction.

## ZigBee technology features and advantages

ZigBee technology has some important features that make it our best option to implement an ad hoc, on-demand, low-cost and low-power location monitoring system. Consider this—if you need battery-powered mobile nodes to implement an efficient location monitoring system, what happens if you have to change batteries every day? ZigBee’s low-cost, low-power capabilities help solve this issue and more.

ZigBee technology’s cost-effective features:

- Operating in 2.4 GHz unlicensed band or one of the sub-GHz regional bands
- Standards-based solution
- Specifically designed to support sensing, monitoring and control applications
- Low complexity (low memory footprint)
- Low power (battery operated devices)
- Mesh networking (a feature not found in most wireless networking standards)
  - Self healing
  - Self forming
  - Multihop routing protocol (AODV routing protocol)

In Table 1 you can see some of the ZigBee technology advantages over other wireless standards. Note that none of the others were designed to address monitoring or control applications.

## RSSI-based location monitoring algorithm

Using RSSI, the MN’s coordinates relative to the SN can be determined within some allowable error, typically less than three meters.

The RSSI-based location monitoring algorithm works in two phases<sup>11</sup>:

- Deterministic phase: This phase involves calibrating the RSSI values of each of the SNs whose location is known. Radio propagation patterns exhibit different non-isotropic path loss due to the various transmission mediums and directions. This is done using an MN. Raw RSSI values are collected at various predefined distances from the SNs, and the calibrated values are then used to determine a suitable propagation constant for each of the SNs.
  - Different mediums (free space, glass and wall) surrounding the SNs affect the signal attenuation differently. Therefore, if only a single propagation constant is used for all SNs, distance miscalculations occur. The calibrated propagation constant takes obstacles into account, and it is calculated as follows:

$$n_i = - \left[ \frac{\text{RSSI}_i - A}{10 \log_{10} d_i} \right]$$

where:

n: Signal propagation constant or exponent

d: Distance from sender

A: Received signal strength at 1 meter distance

- The value A is obtained in a no-obstacle one-meter distance signal strength measurement from the SNs.
- Probabilistic phase: This phase involves distance and position estimation using the propagation constant found in the above phase.
  - Distance estimation: This method is based on the fact that the mobile user does not move arbitrarily, rather there is a correlation between current positions and previous locations.

- Because the strength of the received signal varies dynamically, even if the MN is not moving, it is important to apply a low complexity smoothing algorithm to minimize the dynamic fluctuation of the radio signal received from each SN when the MN is moving. However, for a low-cost solution a coarse location of the subject under search would normally be sufficient.
- The basic assumption for this smoothing algorithm is that the constant velocity motion will result in a constant data change rate and stationary noise processes.
- The estimation and prediction stages for the smoothing algorithm are shown below:

Estimation:

$$\hat{R}_{est(i)} = \hat{R}_{pred(i)} + a \left[ R_{prev(i)} - \hat{R}_{pred(i)} \right]$$

$$\hat{V}_{est(i)} = \hat{V}_{pred(i)} + \frac{b}{T_s} \left[ R_{prev(i)} - \hat{R}_{pred(i)} \right]$$

Prediction:

$$\hat{R}_{pred(i)} = \hat{R}_{est(i)} + \hat{V}_{est(i)} T_s$$

$$\hat{V}_{pred(i+1)} = \hat{V}_{est(i)}$$

where

- $\hat{R}_{est(i)}$  : the ith smoothed estimate range,
- $\hat{R}_{pred(i)}$  : the ith predicted range,
- $R_{prev(i)}$  : the ith measured range,
- $\hat{V}_{est(i)}$  : the ith smoothed estimate range rate,
- $\hat{V}_{pred(i)}$  : the ith predicted range rate,
- a, b : gain constants,
- $T_s$  : time segment upon the ith update.

- Position estimation: To estimate the position of an MN, at least three SNs in the network must be able to detect and measure the MN's signal strength. Trilateration is a method used to determine the position of an object based on simultaneous range measurements from three SNs at known locations. The trilateration, otherwise known as the triangulation technique, is only the first step needed to estimate the position of the node of interest. For instance, if we have been able to measure distances from three SNs, then we will have a triangle, but we have to find the centroid of that triangle to get the initial position of the node we want to locate. We can then initiate one of the well-known location estimation iterative methods.

- Iterative methods, such as weighted linear least squares or maximum likelihood, are applied to derive the MN position according to the estimated distance resolved from filtered RSSI and the calibrated constant. The algorithm requires the coordinates of at least three SNs ( $x_i, y_i$ ) and the distances ( $d_i$ ) between the MN and the respective SNs, which are estimated in the deterministic phase.
- The error estimated is corrected in the estimation. The iteration is repeated until the error is acceptable.

The complete flow of MN estimation of location is shown in the flowchart in Figure 6.

### RSSI-Based Position Location Algorithm

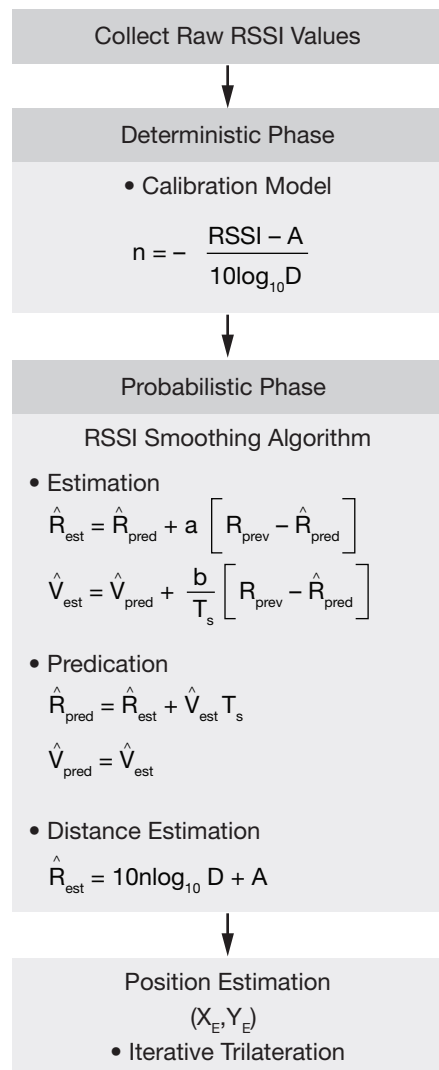
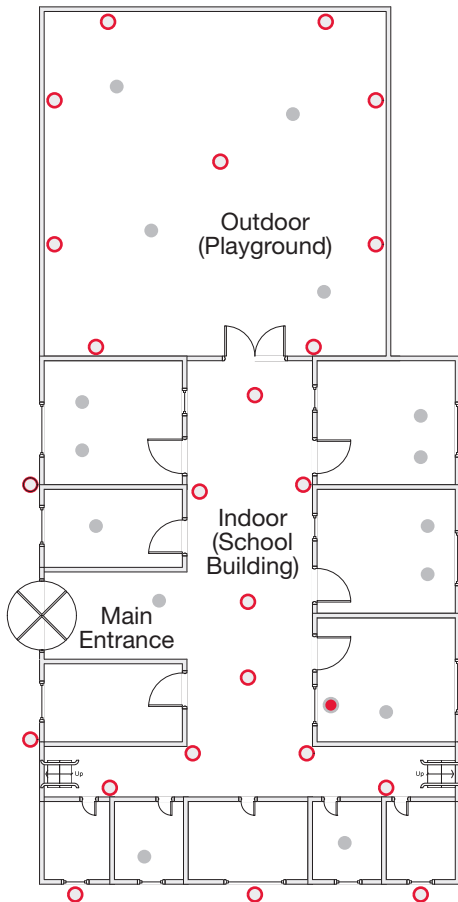

Figure 6

## Placement of Various Nodes on School Premises



■ Static Nodes   
 ■ Gateway Nodes   
 ■ Mobile Nodes

Figure 7

## Position location application

Position location monitoring can be used in the following applications.

### Location monitoring

This application is designed to help school authorities, for instance, keep track of school children while they are on school premises and even locate teachers in case of an emergency.

Figure 7 illustrates sample placements of the three types of nodes in both the indoor and outdoor school environments.

In the above layout, the gateway node is placed in the administration office. In case of multiple floors, each floor may have a gateway node, and all gateway nodes could be networked to the main computer in the administrative office. Static nodes are scattered around the building in such a way that blind spots (i.e. portions not detected by a static node) are minimized and maximum coverage is obtained. The goal is to ensure any mobile node is continuously in contact with three static nodes.

The MNs are embedded in student and teacher ID cards, which ID holders wear at all times while in the school. The gateway node periodically sends out broadcast messages to static nodes to update network information.

Using this network, the school administration can:

- Track student activities
- Broadcast messages about different events, such as school assemblies
- Monitor the time a child spends in certain activity areas and develop a report on his or her behavior for school and parental review
- Automate student attendance records
- Contact teachers when their assistance is needed

If any student is not in a classroom or needs to be located, the teacher can simply type in the student's ID on any computer connected to the GN through the mesh network or even the Internet. The GN would then instruct the SNs to obtain the position of that particular ZigBee mobile node ID.

### Patient monitoring

This application is similar to the school application, and can be used to:

- Monitor patients in different rooms and transmit their vital statistics to a central server (connected to the GN), which can forward those to the doctor in charge
- Ping doctors and medical staff to locate them faster
- Help new patients and employees navigate through the hospital premises
- Monitor the hospital's inventory to locate stored items more quickly
  - In this case the mobile node requires less functionality because it does not need any display or keyboard buttons. The MNs are simple tags that can be attached to the hospital inventory for quick location in an emergency, which can save time critical to patient care

### Local navigation

This application can work in tandem with the local positioning system explained in the previous section. Because the GN contains all network information, it can help a person with an MN navigate to a specific destination in the building. The user would enter a location from a preset menu, then the navigation software built on top of the MN's local position monitoring capabilities can guide the user to the desired location.

### Information exchange

A similar setup can be used for a big event spread over a huge area, where attendees and organizers would be given ID cards that would act as MNs in the network. In addition to monitoring people and helping them navigate through the maze of booths and conference halls, an additional application can be built into the ID Cards which can help people exchange business and

contact information. Through a scrollable menu, the user can select from any of the following application features (Figure 8):

- Find people
  - Similar to student location and patient monitoring
  - Can help to track administrative people or fellow seminar attendees
- Locate a room or hall in the event area using a local navigation function
- Exchange contact information and notes
  - Allow users to exchange contact information, notes (large messages could be broken into smaller ones and then reassembled after receipt) and business cards, which could be downloaded to a PC at the event and transferred to a CD or flash drive for personal use
  - Sending short messages to fellow attendees or organizers

### Sample Design of ZigBee® Enabled ID Card

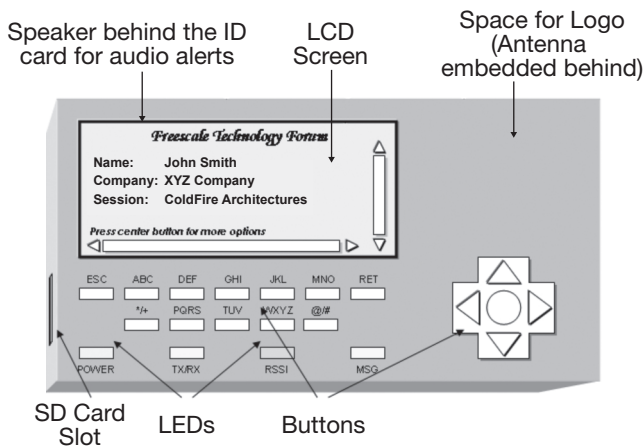

Figure 8

## Freescall enables location monitoring with ZigBee technology

Freescall has an extensive portfolio of ZigBee-enabled ICs and low-power microcontrollers (MCUs) that make up the ideal platform for ZigBee-enabled networks.

Freescall's MC13224V ZigBee Platform in Package™ (PiP) is the latest of our low-power platforms for ZigBee devices. The highly integrated MC13224V PiP simplifies RF design, allowing many customers who do not have extensive RF experience to still create robust ZigBee-enabled designs. Freescall also has a number of reference designs that include the design details for the hardware in the development kits. You can take the bills of materials, Gerber files and schematics and either copy our design or integrate it into yours. The complete platform approach helps reduce development time and speed time to market.

### MC13224V PiP key features include:

- IEEE 802.15.4 standard-compliant on-chip transceiver/modem
  - 2.4 GHz
  - 16 selectable channels
  - Advanced encryption/decryption hardware engine (AES 128-bit)
- Low power
  - 21 mA typical current consumption in RX mode with MCU active
  - 29 mA typical current consumption in TX mode with MCU active
- 32-bit ARM7TDMI-S™ CPU core with programmable performance up to 26 MHz (24 MHz typical)
- Extensive on-board memory resources
  - 128 KB serial flash memory (can be mirrored into RAM)
  - 96 KB SRAM
  - 80 KB ROM
- Best-in-class power dissipation
- Extensive MCU peripherals set
  - Dedicated NVM SPI interface for managing flash memory
  - Two dedicated UART modules capable of 2 Mbps with CTS/RTS support
  - SPI port with programmable master and slave operation
  - 8-pin keyboard interface (KBI) supports up to a 4x4 matrix
  - Two 12-bit analog-to-digital converters (ADCs) share eight input channels
  - Up to 64 programmable I/O shared by peripherals and GPIO
- No external RF components required
  - Only an antenna is needed for single-ended 50Ω RF interface (balun in package)
  - Only a crystal is required for the main oscillator; programmable crystal load capacitors are on-chip
  - All bypass capacitors in package

For further details, please see the MC13224v reference manual<sup>[2]</sup>.

Freescall's BeeStack™ ZigBee-compliant stack with BeeKit™ Wireless Toolkit provides a simple software environment to configure network parameters. This tool is unique to Freescall, allowing customers to use a wizard and drop down menus to help configure the ZigBee network parameters.

Freescall's MC13224V ZigBee Evaluation Kit (Part #1322xEVK) is specifically targeted for developing ZigBee-enabled products, providing the necessary hardware and software tools to streamline the development process. For customers running the ZigBee protocol who require a different low-power MCU, they can combine the MC13202 RF transceiver and the Flexis QE128 MCU. The MC1320x-QE128-DSK provides a simple and cost-effective development platform.

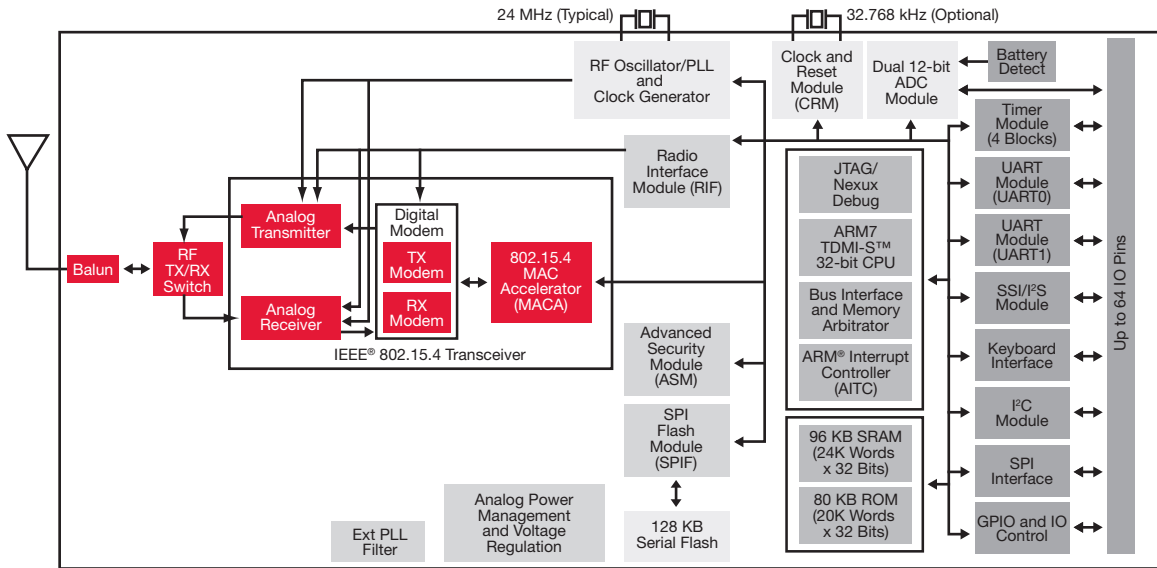

Figure 9

The MCF520x<sup>(4)</sup> family of ColdFire controllers answers the call for a low-cost, flexible memory controller that supports a combination of external SRAM, flash memory and a choice of single-data rate (SDR), double-data rate (DDR) or mobile-double-data rate (M-DDR) SDRAM memory. The cost-effective, fully-functional and easy-to-use M5208EVB kit simplifies MCF5208 product development and speeds customers to market.

## Summary

In short, Freescale-enabled location monitoring using IEEE 802.15.4/ZigBee technology can help make lives safer and healthier. Products such as the MC13224V PiP allow designers to implement low-power, cost-effective ZigBee mesh networks that can provide effective location monitoring for a variety of environments.

## References

- [1] “Enhanced RSSI-Based Real-Time User Location Tracking System for Indoor and Outdoor Environments,” Erin-Ee-Lin Lau and Wan-Young Chung, Dongseo University, Korea, 2007 International Conference on Convergence Information Technology, [ieeexplore.ieee.org/stamp/stamp.jsp?arnumber=04420422](http://ieeexplore.ieee.org/stamp/stamp.jsp?arnumber=04420422)
- [2] MC13224V Advanced ZigBee® Compliant SoC Platform for the 2.4 GHz IEEE® 802.15.4 Standard Reference Manual, [www.freescale.com/files/rf\\_if/doc/data\\_sheet/MC1322x.pdf](http://www.freescale.com/files/rf_if/doc/data_sheet/MC1322x.pdf)
- [3] “Locating the Nodes: Cooperative Localization in Wireless Sensor Networks,” N. Partwari, J. N. Ash, S. Kyperountas, A. O. Hero III, R. L. Moses and S. D. Correal, IEEE Signal Processing Mag., vol. 22, no. 4, pp. 54–69, July 2005, [ieeexplore.ieee.org/xpl/freeabs\\_all.jsp?arnumber=1458287](http://ieeexplore.ieee.org/xpl/freeabs_all.jsp?arnumber=1458287)
- [4] MCF5208 ColdFire® Microprocessor Data Sheet, [www.freescale.com/files/32bit/doc/data\\_sheet/MCF5208EC.pdf](http://www.freescale.com/files/32bit/doc/data_sheet/MCF5208EC.pdf)

Oziel Hernandez Salgado is a software engineer at Freescale’s Wireless Connectivity Operation in Mexico. He has a bachelor of science degree in computer science and a master’s degree in telecommunications. Varun Jain, Prashant Bhargava and Suhas Chakravarty are design engineers at Freescale’s India Design Center. Each holds a bachelor of engineering in electronics and communication.



Jose Palazzi

# Beyond Isolation

## Low-cost isolated digital link

This article provides an overview on how to use two ultra-low-cost 8-bit Freescale microcontrollers (MCUs) and an electromagnetic isolation barrier in a self-healed arrangement to implement a multi-channel isolated digital link for potential use in medical diagnostic equipment.

Isolation is a frequent requirement for any application in which common mode voltage can compromise integrity. In medical applications, both the equipment and the patient need protection from hazardous voltages or currents. For instance, electrocardiogram (ECG) systems use sensors that are connected to the patient. If the system causes even a small amount of AC current to flow through the human body, it could be fatal. In another example, the high voltages present in electrodes when defibrillators are operated could potentially kill conditioning circuits in the signal processing patch. Safety regulations, such as IEC60601-1, UL 2601-1, IEC601-1 and CSA C22.2 No. 601, mandate isolation with strict safety laws, rules and guidelines governing the design and construction of medical devices.

Optocouplers, which isolate electronic circuits connected to the patient, offer inherent immunity to electrical or magnetic fields. However, the high input current needed to drive the internal LEDs and its consequent degradation over time limits the long-term use of these devices.

On the other hand, electromagnetic coupling provides extremely high isolation with no degradation. The implementation proposed in this article consists of two MCUs used to control the flow of data across an electromagnetic isolating barrier. Thanks to the highly integrated ultra-low-cost MCUs from Freescale, such as the MC9RS08KA series, multi-channel isolation is possible using just two very small 8-pin devices.

### Energy to one side and signal to the other

The block diagram in Figure 1 shows how the 3-input isolated digital link is implemented. Using the single isolation element to transport three signals through the isolation barrier represents a significant cost reduction over individual isolation elements.

An ultra-low-cost 8-pin MCU at the isolated side monitors the logic level of three GPIO pins and packs the information into a serial protocol. Using a special modulation technique, this information is sent through the isolation barrier, made with the transformer, to the demodulator side.

Another ultra-low-cost 8-pin MCU is used at the demodulator side to recover the modulated information. However, instead of decomposing the signals in three pins, this device communicates to a host through a single pin interface, which reduces system I/O count.

### 3-Input Isolated Digital Link

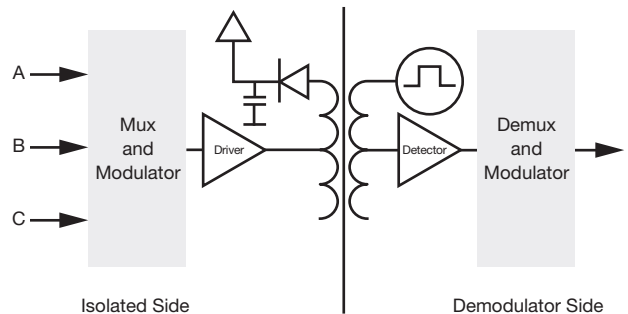

Figure 1

In addition, the proposed solution supplies DC voltage to the isolated side using the transformer as an isolated converter.

A square wave signal generated by the MCU in the demodulator side is used to charge the inductor that is wound in one side of the isolation transformer. Integrating two inductors in the same magnetic core allows energy to be transferred from the demodulator side to the isolated side. A rectifier diode, capacitor and regulator are added to the isolated side to form a stable DC supply source for the MCU.

The typical MCU power consumption suggested for this implementation is 5 mA at 10 MHz clock frequency. The modulation will add approximately 3 mA, thus configuring a maximum power consumption of 8 mA at the isolated side.

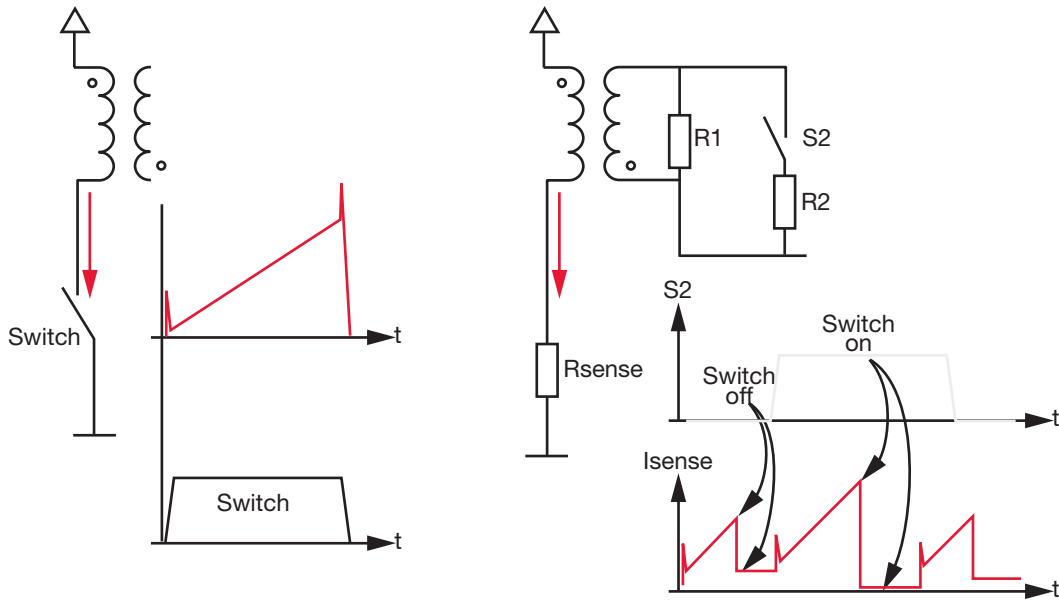

Figure 2

**Direct current modulation**

This solution is suitable for applications where speed is not as critical as serialization, demodulation and protocol handling, which are performed by the MCU executing instructions in sequence. Thanks to the stable behavior of the isolated circuit at the primary side, a simple technique using direct current modulation can be used with high reliability and repetitiveness without requiring extreme processing horsepower from the MCU. Figure 2 shows how direct current modulation works.

On the left side, when the SWITCH is closed, the DC current across the inductor (primary side of the transformer) follows the equation:

$$E = L * di / dt \text{ where:}$$

E = Voltage applied to the inductor

L = Inductance

di = DC current of the inductor

dt = Charge time

The primary inductance of the transformer is calculated as a function of operating frequency, supply voltage and required max DC current. Energy stored in the transformer during the “on” time is transferred to the secondary side during the “off” time, similar to switched mode power supplies.

Now things become interesting. As the current drained at the secondary side of the transformer is reflected to the primary side, changes in the DC consumption can be detected at the primary side of the transformer.

Figure 3 illustrates how we can transform this into something useful. A hardware level protocol is implemented using a two-level current modulation scheme, with a frame flag alerting the

demodulator side when the isolated side is ready to transmit a package. Isync represents the additional average current increase in the primary side when the frame flag is on. After the isolated side sends the serial stream of data, the frame flag is turned off, signaling the demodulator side that the data transfer cycle is finished.

**Direct Current Modulation Waveforms**

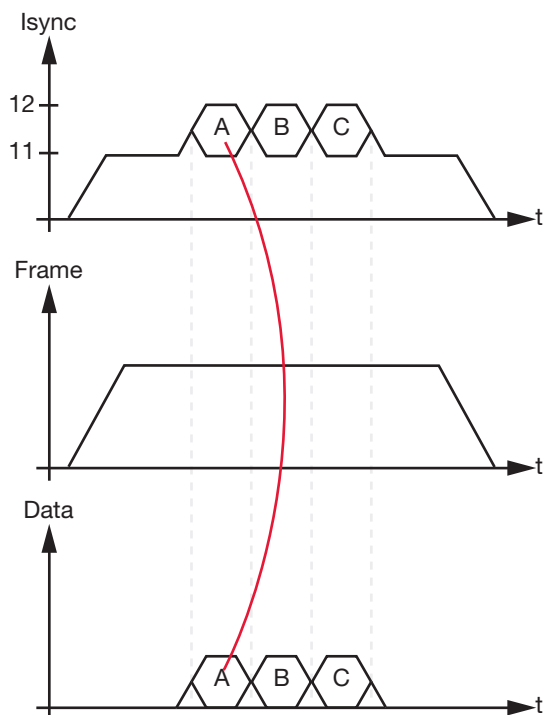

Figure 3

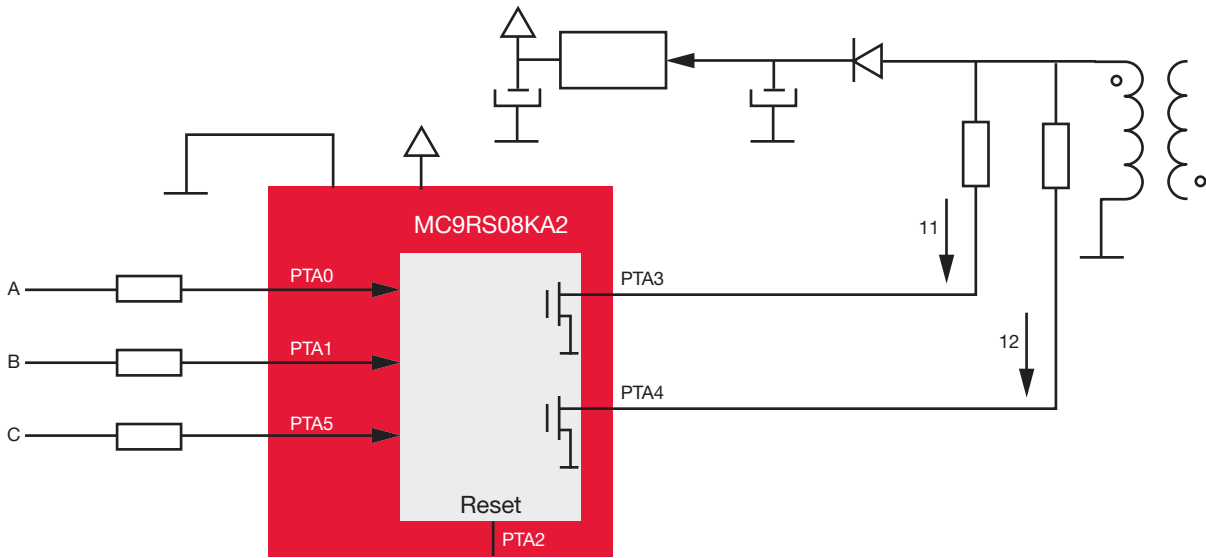

Figure 4

## Putting it all together

Figure 4 is a simplified circuit diagram for the proposed isolated side while Figure 5 is a simplified circuit diagram for the proposed demodulator side.

At the isolated side, the rectifier diode, capacitor and series regulator form a DC source to supply  $V_{DD}$  to the MCU. The wide supply range Freescale specifies for small MCUs (1.8V to 5.0V) adds flexibility when specifying the transformer. For instance, with a 1:1 transformer excited by a 50 percent duty cycle 5V supply, output voltages of near 2V could be expected at the voltage regulator input.

PTA0, PTA1 and PTA2 pins receive A, B and C signals. PTA3 and PTA4 are connected as current sinks modulating the current consumption directly in the transformer pins. The MCU's low voltage detection (LVD) helps prevent abnormal operation when the supply voltage is not sufficient to guarantee the operating conditions.

On the demodulator side, as illustrated in Figure 5, PTA4 generates a square wave signal to switch on and off the transistor implementing the primary side of the flyback converter. A current sensor resistive element is connected between the emitter and GND so the current level across the transformer and through PTA1 can be measured.

As shown in Figure 4, a sampling window is set to detect the current modulation. The voltage comparator inside the ultra-low-cost MCU has been designed to operate across the full range of the supply voltage (rail-to-rail operation) with extreme flexibility.

Figure 6 shows the internal implementation of the voltage comparator block.

In our demodulator circuit, PTA1 receives the primary current signal through the RC network. A multi-level voltage detector is implemented using the MCU's internal 1.21V reference, and the three-resistor network is implemented around PTA5, generating a reference voltage for the non-inverted input of the voltage comparator. This MCU-controlled network allows the DC current detector to be dynamically configured to detect specific trip points during the system operation and to correlate those to the "truth demodulation table" stored in the MCU's flash memory.

PTA3 is used to deliver a 1200 bps, 8, N, 1 asynchronous TX data signal that can be read by any UART/SCI interface. The firmware in the demodulator side can be configured to generate continuous sampling or to generate a data stream every time a new updated packet is transferred from the isolated side.

## Conclusion

This proposed implementation with two ultra-low-cost MCUs does not exhibit high signal speed due to the nature of the MCUs' ability to execute the codes that perform the expected tasks. On the other hand, the cost and longevity of Freescale products offer several advantages over using one optocoupler per signal in low-speed applications. Flexibility for customizations, high breakdown voltage, low power consumption and high immunity to transients along with low cost and increased longevity make the proposed solution favorable for medical applications.

A prototype has been built using two Freescale MC9RS08KA2 MCUs. The RS08 core allows the development of compact code and has been optimized for small memory sizes.

## Proposed Demodulator Side

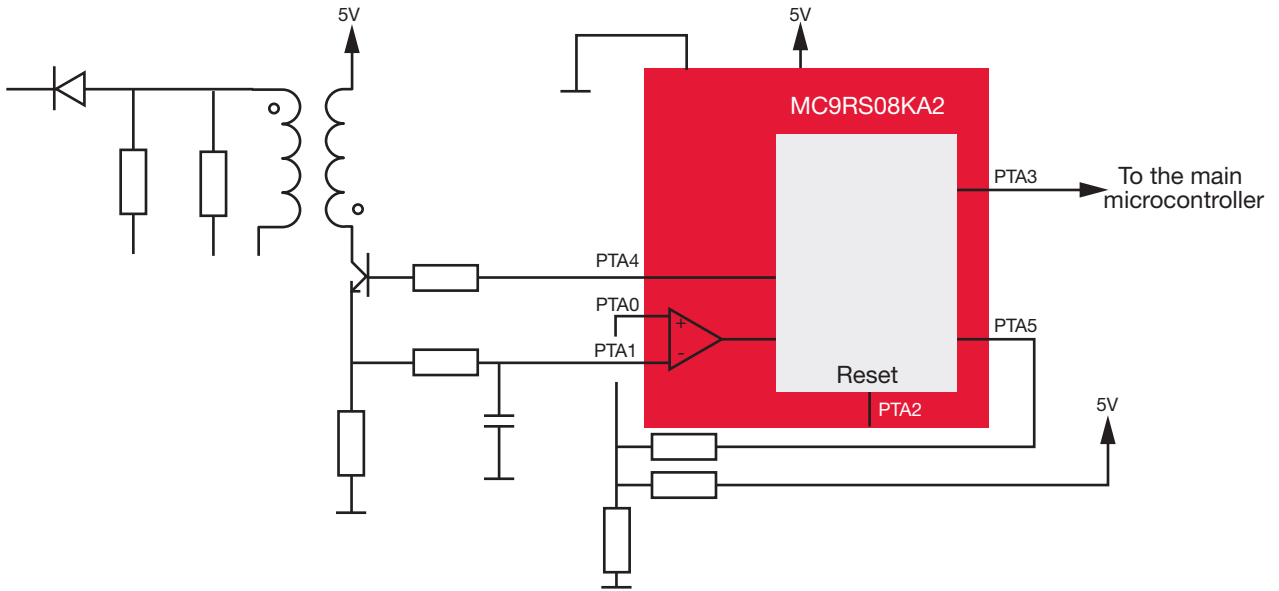

Figure 5

## Voltage Comparator Block

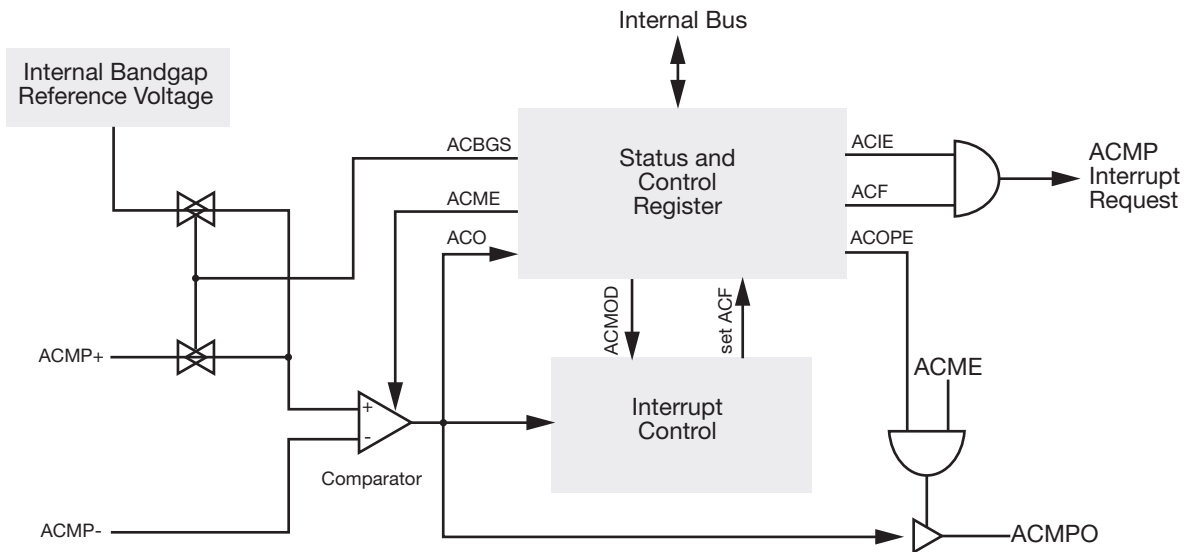

Figure 6

Operating at up to 10 MHz clock speed, with an internal background debug module and a precise trimmable oscillator that ensures greater stability, this small MCU is available in 8-pin DIP and 8-pin SOIC packages.

Breakdown voltages, lower power consumption and immunity to transients have direct effects on the transformer's construction and materials. In experiments conducted by the author with

toroidal ferrite cores, breakdown voltages in excess of 8 Kv were repeatedly experienced. Immunity to transients in the HF spectrum (1 MHz to 30 MHz) was obtained using a "drum core" construction associated with good ground planes in the PCB. E-shape cores present high immunity to coupled transients, which allows the operation close to inductive loads connected to a 50–60 Hz AC supply.

Jose Palazzi worked many years as a field application engineer for microcontrollers and microprocessors and has a solid background in the development of electronic circuits for consumer and industrial applications. Jose is a sales account manager in Sao Paulo, Brazil.

Suhas Chakravarty, Varun Jain, Nakul Midha and Prashant Bhargava

# Low-Cost Driver Assistance

## Using ZigBee<sup>®</sup>/IEEE<sup>®</sup> 802.15.4

### Introduction

According to some investigations, intelligent driver assistance systems can prevent 20 to 30 percent<sup>(3,4)</sup> of road accidents. In the years to come, driver assistance systems will be required safety features rather than options. The main challenge for the automotive industry is how to make these systems cost-effective so they can be embedded into small and mid-segment cars as well as high-end models.

Current driver assistance systems are based on a number of technologies, such as radar, computer vision and sensors. Integrating all of these technologies into a single system is normally a costly and complex solution. We propose a complete ZigBee<sup>®</sup> based driver assistance system solution that leverages the cost-effective, low-power and secure wireless networking features of the ZigBee protocol.

The solution seeks to alert and inform the driver whenever the vehicle approaches a preset waypoint on the road. A ZigBee-based unit is installed at each waypoint, broadcasting relevant information to corresponding ZigBee units embedded in approaching vehicles. Such a system significantly reduces the reliance on human vision and on-road lighting conditions.

This highly flexible concept can perform the following functions:

- Alert the driver to approaching traffic, stretches of road under maintenance, school and hospital zones, vehicles approaching around a blind corner and many other hazardous conditions.
- Serve as milestones, road signs and simple advertisements, such as the menu of a nearby drive-in restaurant.
- Be used as waypoint nodes to record and transmit traffic statistics, such as the number of vehicles passing through an intersection. These nodes can be linked to sensors measuring air quality, temperature or humidity at important locations in the city, and all readings can then be broadcast through a mesh network of various waypoint nodes to in-car units and a central gateway node for further processing.

- Be used for automated, unmanned toll collection for parking lots and toll roads where a secure ZigBee link can help carry out toll transactions before the vehicle reaches the entry point.

In summary, any application that requires car-to-road communication, with a moderate amount of data involved, would benefit from the solution.

### The ZigBee network

The ZigBee networking stack is built upon the IEEE<sup>®</sup> 802.15.4 standard that defines the physical (PHY) and medium access control (MAC) layers for a low-data-rate, low-power network. ZigBee adds network (NWK) and application (APL) layer specifications on top of 802.15.4 to complete what is called the full ZigBee stack.

More details on the ZigBee network can be found in the additional Beyond Bits 4 article, Location Monitoring Using ZigBee/IEEE 802.15.4.

The solution network has the following types of ZigBee nodes:

- Gateway Node: This node in traffic control or police stations synchronizes and collects information from waypoint nodes in the vicinity. Each gateway node would connect with the Internet through an Ethernet connection. Thus, the Internet serves as a backbone, connecting all gateway nodes together. Traffic data logging applications and, in general, any sort of application that falls within the purview of the city administration and requires extensive coverage, needs a network of waypoint nodes. This is to facilitate central data collection and analysis as well as remote node updating and maintenance.
- Waypoint Nodes: There are two types of waypoint nodes: networked and stand-alone. Networked nodes perform heavy data logging operations and are permanently linked with a gateway node. Such nodes could be placed along major thoroughfares, freeway entrances and exits and at major intersections. In addition to capturing and transmitting traffic information, these nodes could broadcast useful driver information, such as nearby gas stations or hospitals, to

car unit nodes. These waypoint nodes should be capable of handling traffic on either side of the road. Thus, each car unit would inform the waypoint node about its heading and the waypoint node would respond with pertinent information. Since these nodes are mesh networked with the gateway node, they can be updated with information on new landmarks and utilities in their vicinity.

Stand-alone nodes are temporarily deployed and may or may not be linked to gateway nodes in the area. They can be used as emergency notification nodes that warn approaching traffic about accidents, construction in progress and other road hazards. These would be removed once the hazard has been resolved. Stand-alone waypoints can also serve as advertisements, which would not require a connection to the city administration waypoint network.

- **Car Unit Nodes:** These are the nodes placed in each car to communicate with waypoint nodes. These nodes would have a human interface, such as a keypad, LED display or LCD, for user-friendly access to the system.

In Figure 1, the waypoint nodes marked 1–4 could effectively:

1. Provide alerts about traffic at potential blind spots
2. Provide information on various landmarks, such as gas stations, malls and hospitals
3. Provide information about approaching trains at a railroad crossing
4. Temporarily provide a warning about construction and other traffic obstructions

In the next sections we will see how all the nodes working together can collectively support multiple applications.

### Example of Typical Node Placements

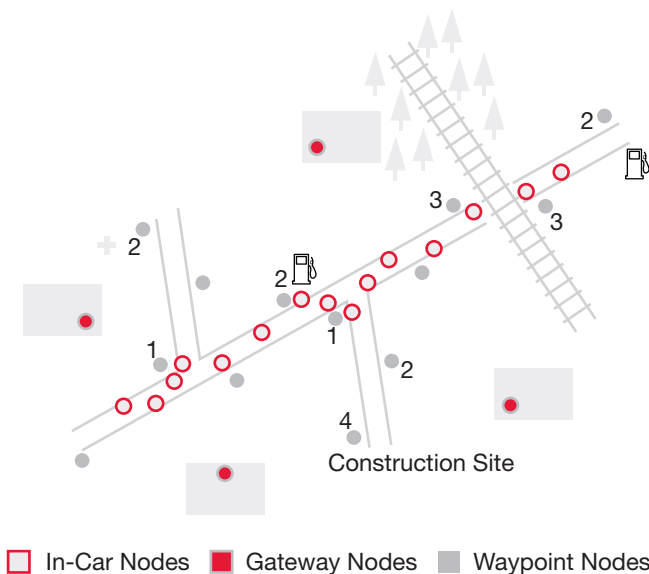

Figure 1

## Setup

Every ZigBee car unit node has a unique ID assigned to it, much like the vehicle's registration number. At periodic intervals, the car unit sends out a "ping" packet that includes the ID. On receiving a ping, a waypoint unit will transmit a particular message in return.

## Application

On a broad level, the applications can be classified in the following three categories:

1. Alert scenarios
2. Information broadcasting
3. Data logging

## Alert scenarios

These scenarios use the information to alert drivers to hazardous situations on the road ahead. A waypoint unit detects an approaching vehicle and transmits an alert message that identifies upcoming hazards, such as:

- Speed bumps or breakers
- Blind turns
- Road maintenance
- No parking, no entry or speed limit changes, such as school zones
- Pedestrian crossings and hospital or fire station entry and exit points
- Approaching vehicles on single lane curved roads, especially in hilly areas

Figure 2 shows how waypoint units are placed to give the automobile driver advanced warning in time to take corrective actions. The process for warning vehicles in a blind turn vicinity could be as follows:

- In Figure 2, the waypoint node detects car A approaching the intersection (receives the car's ping).
- The waypoint node logs car A's ID and transmits a "blind corner" alert.
- On receiving this warning packet, the car unit in car A will give the driver both an audio and visual warning of the "blind corner" alert.
- Now, while car A is still within the range of the waypoint node, car B comes within range of the waypoint node.
- The waypoint node detects car B and changes its broadcast message to "multiple cars approaching blind turn." Because it is a broadcast, it is received by both cars.
- Again, car units of both cars sound warnings and light up a red LED. A warning message is also displayed on each car's LCD.
- The drivers of both cars can slow or stop as required.
- When both cars leave the range of the waypoint node, the node stops broadcasting.



## Advanced Warning Approaching Corners and Obstacles

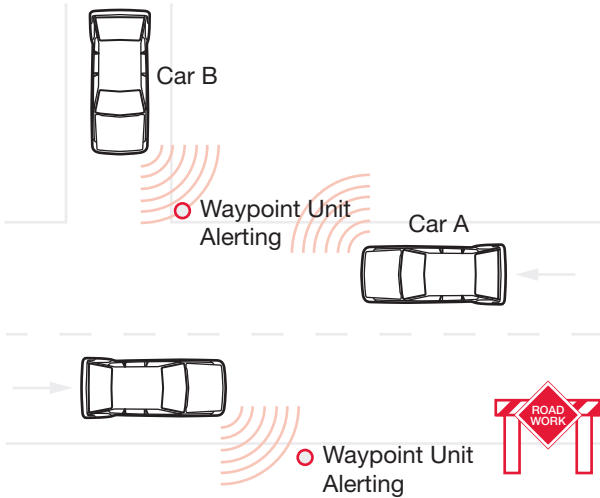

Figure 2

For all alert scenarios, the placement of the waypoint units must allow the alert message to be sent out early enough to give the driver enough time to react. The correct placement of the unit depends on the following factors:

Factor 1: The broadcast range of the waypoint unit or the car unit (whichever is shorter)

Factor 2: The data rate of the ZigBee link between the car and the waypoint unit

Factor 3: The average human reaction time

Factor 4: The posted speed limit, which helps determine the average distance it takes for the car to come to a halt

Let's assume a case where car A and car B are approaching the blind turn at 70 Km/h (19.44 m/s), simultaneously, which is the posted speed limit (Factor 4). Factor 1 equals 50m (conservative estimate), and the data rate is 50 Kbps (Factor 2). At 70 Km/h, the approximate stopping distance is 43m, which includes driver reaction time. Let's say the alert message is 800 bits long.

A and B would be detected at a distance of 50m from the waypoint node, and at 50 Kbps, 16 ms elapse in transmitting an 800-bit alert message, within which time the cars travel a distance of around 32 cms. Subtracting this figure from 50m still leaves us comfortably placed within the 43m stopping distance.

## Information broadcasting

This category of applications provides the driver with information that ranges from one level below safety-critical to simple advertisements for various commercial establishments. Some examples are:

- Road signs
- Nearest petrol/gas filling stations
- Nearest hospitals, hotels, markets, car service stations and landmark information
- Directional guides, such as destination A is 2 km straight, destination B is 3 km right and destination C is 3 km left from the present location
- Advertisements for roadside eateries

## Data logging

Each waypoint unit at major intersections and on major freeway entry and exit points can maintain a log of passing vehicle IDs plus a timestamp. Nodes can timestamp the entry and exit of vehicles in their hearing range and log the duration spent within this range. This can help the city planners profile the traffic patterns and volumes.

## Roadside Facilities and Landmark Information Access

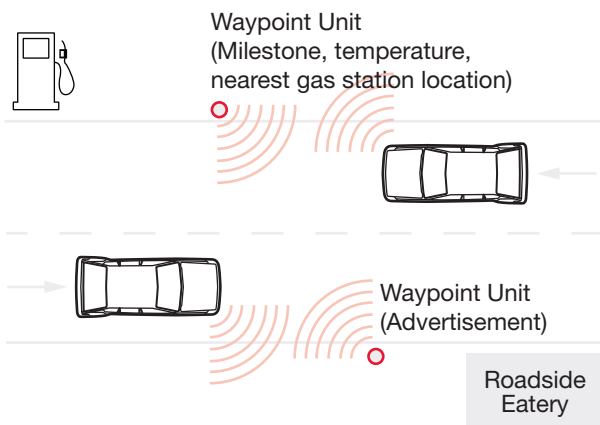

Figure 3

## Fugitive Vehicle Tracking

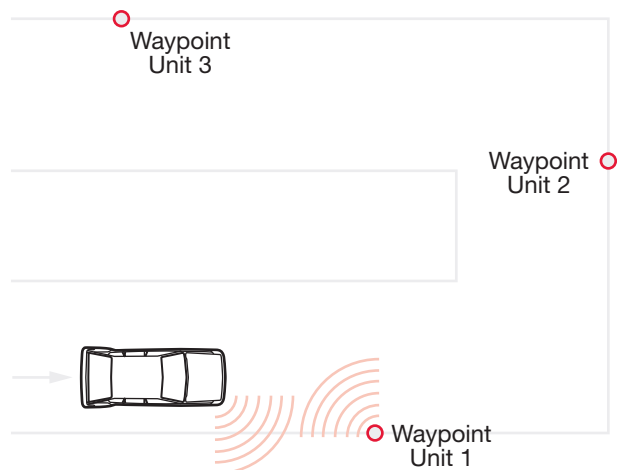

Figure 4

in a given location, a few dozen waypoint units could be connected through a mesh network to a gateway node, which, in turn could be integrated with an administration office LAN. The gateway node would update its master log by regularly querying each waypoint unit in the mesh network. The information from the master log could be pulled to create a consolidated report on a daily or monthly basis. By integrating air quality, temperature and humidity sensors with the same waypoint units, the locality's air quality can also be effectively monitored. Since these applications will require intensive data logging, fast, high-endurance, non-volatile memory with error correction capability should be included in the waypoint units.

The solution could also be used to track stolen or fugitive vehicles via the following steps:

- Once an alert for a particular vehicle has been issued, every gateway node is sent the vehicle's ZigBee unit's ID.
- The gateway nodes then pass it on to their respective waypoint units, along with a "red alert" packet.
- The waypoint units then enter a special mode where they compare each vehicle ID they log with the "red alert" ID. When a waypoint unit finds a match, it alerts the gateway node.
- A rough route of the vehicle can be tracked, including the time each waypoint unit identified the vehicle.

## System details

We introduce the terms "mobile unit" and "static unit" here. The ZigBee unit installed in the vehicle is called the mobile unit, while a waypoint unit on the road is the static unit.

In a mobile unit, an LCD screen and an array of LEDs on a vehicle's dashboard serve to display the messages and alert the driver along with audio warnings. The kind of LCD used (segmented or color) depends on the kind of MCU used and the cost of the unit. If the MCF1322x Platform in a Package™ (PiP)<sup>(1)</sup> is used, then the LCD can be connected via SPI. LEDs

### Mobile Unit Design without LCD

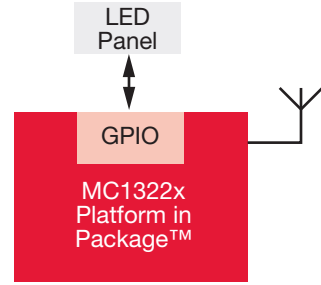

Figure 6

### Static Unit Design

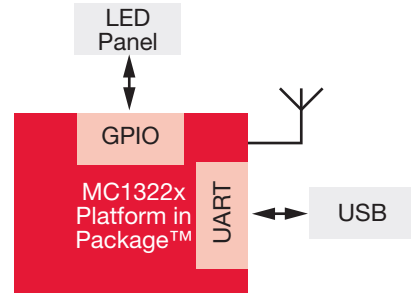

Figure 7

can be applied through GPIOs or RGPIOs and can be used in a low-cost solution in place of an LCD. Also, waypoint nodes and gateway nodes do not require LCDs, as a technician can connect the node to a laptop to view its information during debug and maintenance. Audio alerts are a must for all mobile nodes.

To conserve power, the static unit is in sleep mode most of the time, waking up when it detects an approaching vehicle. Solar energy can also be used to power the waypoint and recharge its batteries for enhanced 24-hour energy efficiency.

### Static Unit Design for Traffic Monitoring and Vehicle Tracking

### Mobile Unit Design with LCD

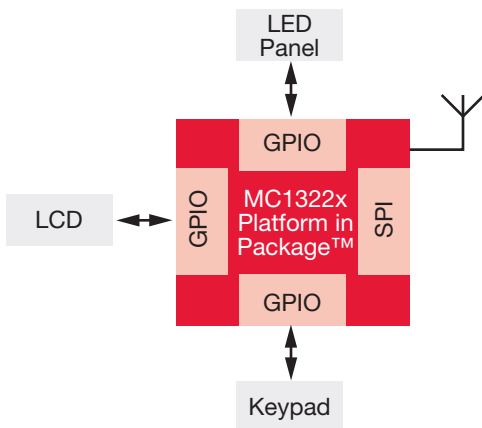

Figure 5

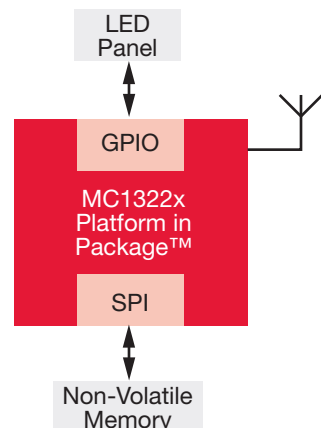

Figure 8

## The Freescale advantage

Freescale provides all the building blocks used to develop a complete ZigBee-compliant platform solution, including hardware, software, tools and reference designs. Freescale offers hardware solutions ranging from a single-chip advanced ZigBee-compliant PiP<sup>[1]</sup> to a simplified two-chip solution with a ZigBee transceiver (radio) and a low-power microcontroller (MCU). In a two-chip solution, the MCU should include an LCD controller or two or more SPI interfaces. ZigBee features, such as the ability to securely transfer messages over a channel without interfering with other wireless networks<sup>[5]</sup>, ensures that the data is delivered intact.

All modules would include a Freescale MC1322x MCU, featuring:

- 128 KB serial flash
- 96 KB static RAM
- 80 KB ROM
- Hardware acceleration for IEEE 802.15.4

Car units have these extra onboard components:

- LED panel to indicate alerts and other vital information
- LCD panel (optional) to display the messages transmitted by waypoint nodes

Waypoint nodes with data logging capability will also have SPI flash, which can be interfaced with the SPI on board the MC1322x MCU.

Freescale also provides a full integrated development environment (IDE) for developing embedded applications. The IDE is complemented by the BeeKit™ Wireless Connectivity Toolkit, a comprehensive package of wireless networking libraries, application templates and sample applications.

## Summary

In this article we discussed the importance of an efficient driver assistance system and how it can help us improve safety standards on the road. The solution can significantly reduce the risk to drivers and enable better traffic management. Our ZigBee-based driver assistance system provides a very cost-effective alternative to more expensive commercially adopted systems like GPS, which provide navigation but do not have any fore-warning capabilities. Further details on the comparison of ZigBee with other wireless protocols can be found in the additional Beyond Bits 4 article, Location Monitoring Using ZigBee/IEEE 802.15.4.

We showcased a number of ZigBee-enabled application scenarios related to automotive and road safety, such as data logging, information broadcasting and driver alerts. In today's market, where many solutions are emerging that are related to vehicle-to-vehicle and vehicle-to-road communications, we believe Freescale's ZigBee solutions can play a larger role in promoting a safer, more informative driver experience.

## References

- [1] MC1322x Advanced ZigBee-Compliant SoC Platform for the 2.4 GHz IEEE 802.15.4 Standard Reference Manual, [www.freescale.com/files/rf\\_if/doc/data\\_sheet/MC1322x.pdf](http://www.freescale.com/files/rf_if/doc/data_sheet/MC1322x.pdf)
- [2] [www.freescale.com/zigbee](http://www.freescale.com/zigbee)
- [3] Research On The Road To Intelligent Cars, ScienceDaily (Mar. 11, 2006), [www.sciencedaily.com/releases/2006/03/060311090833.htm](http://www.sciencedaily.com/releases/2006/03/060311090833.htm)
- [4] Concept of an Intelligent Adaptive Vehicle Front-Lighting Assistance System, H. Shadeed, J. Wallaschek; Proceedings of the 2007 IEEE Intelligent Vehicles Symposium
- [5] Zonal Location and Asset Tracking with ZigBee Technology (using RSSI), Cambridge Consultants (Oct. 12, 2006), [www.zigbee.org/imwp/idms/popups/pop\\_download.asp?contentID=9567](http://www.zigbee.org/imwp/idms/popups/pop_download.asp?contentID=9567)

Nakul Midha, Varun Jain, Prashant Bhargava and Suhas Chakravarty are design engineers at Freescale's India Design Center. Nakul and Varun have performed verification and validation of various SoC projects. Prashant has worked in design, architecture and verification of SoC and IP projects while Suhas has been working in SoC architecture and design. All hold bachelor of engineering degrees in electronics and communication.

Deepak V. Katkoria and Alberto C. Arjona

## 3-D Facial Recognition System Based on the MPC5121e microprocessor

### Introduction

Research in computer graphics has brought attention to 3-D modeling. With advanced progress in image recognition models, designers have opened a whole new field of applications, including 3-D human face recognition. This article proposes a design and algorithm for a 3-D facial recognition system using Freescale's versatile MPC5121e microprocessor. Its triple-core architecture features an e300 Power Architecture® processor core, 2-D/3-D graphics engine (MBX) and audio processor (AXE) core.

### Face detection algorithms

To measure distance via triangulation, the calculation uses the baseline distance between a laser beam and a camera as well as their angles to a target point (see Figure 1).

#### Triangulation Principle

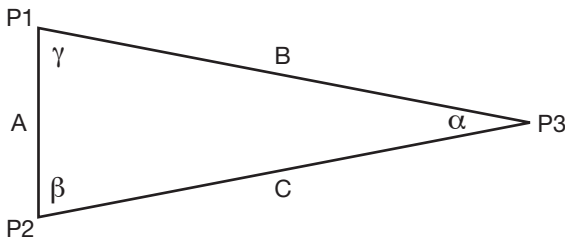

Figure 1

P1 and P2 represent two reference points, the camera and laser beam, while P3 is a target point. The range B can be determined from the known values of the baseline separation A and the angles β and γ using the Law of Sines:

$$\frac{\sin \alpha}{A} = \frac{\sin \beta}{B} = \frac{\sin \gamma}{C} \quad (1)$$

In practice, this is difficult to achieve because the baseline separation and angles are hard to measure accurately. However, a demonstrated technique for obtaining range information via laser triangulation without knowing the values of A, β and γ has been developed. The algorithms of this technique could be successfully implemented in 32-bit processors, such as the MPC5121e multicore processor.

### MPC5121e implementation

The MPC5121e integrated processor includes multiple cores and multiple buses that provide higher performance and allow for lower system cost and higher reliability.

The MPC5121e processor's rich set of integrated peripherals includes PCI, parallel advanced technology attachment (PATA), Ethernet, USB 2.0, twelve programmable serial controllers (PSC), display controller (DIU) and video-in unit (VIU), all of which fulfill the requirements for a facial recognition system.

The system can use the integrated display controller (DIU) to support an LCD display with a maximum resolution of 1280 x 720p and color depth of up to 24 bits per pixel. This will create an excellent image model for the user. Another advantage of DIU is its blending capability, which can be used to blend up to three different planes on the display. The system uses DIU for displaying the image model and for overlaying the data images to guide the user's decision making process.

The VIU plays a crucial role in the system's video interface. The VIU core accepts an ITU656-compatible video stream from the video camera, providing a wide selection of display modes, from QVGA to XVGA 8-bit/10-bit ITU656 video input.

The internal DMA engine transfers all incoming video data from FIFO to memory. This data is analyzed and computed using the triangulation algorithm mentioned above. Once the processor calculates the position of the vertex (point of interest) from the memory, then the matrix parameters are transferred to the MBX core. This is a 3-D accelerator that recreates a real-time rendering of the matrix (stored in memory) on the display.

## Facial Recognition System Block Diagram

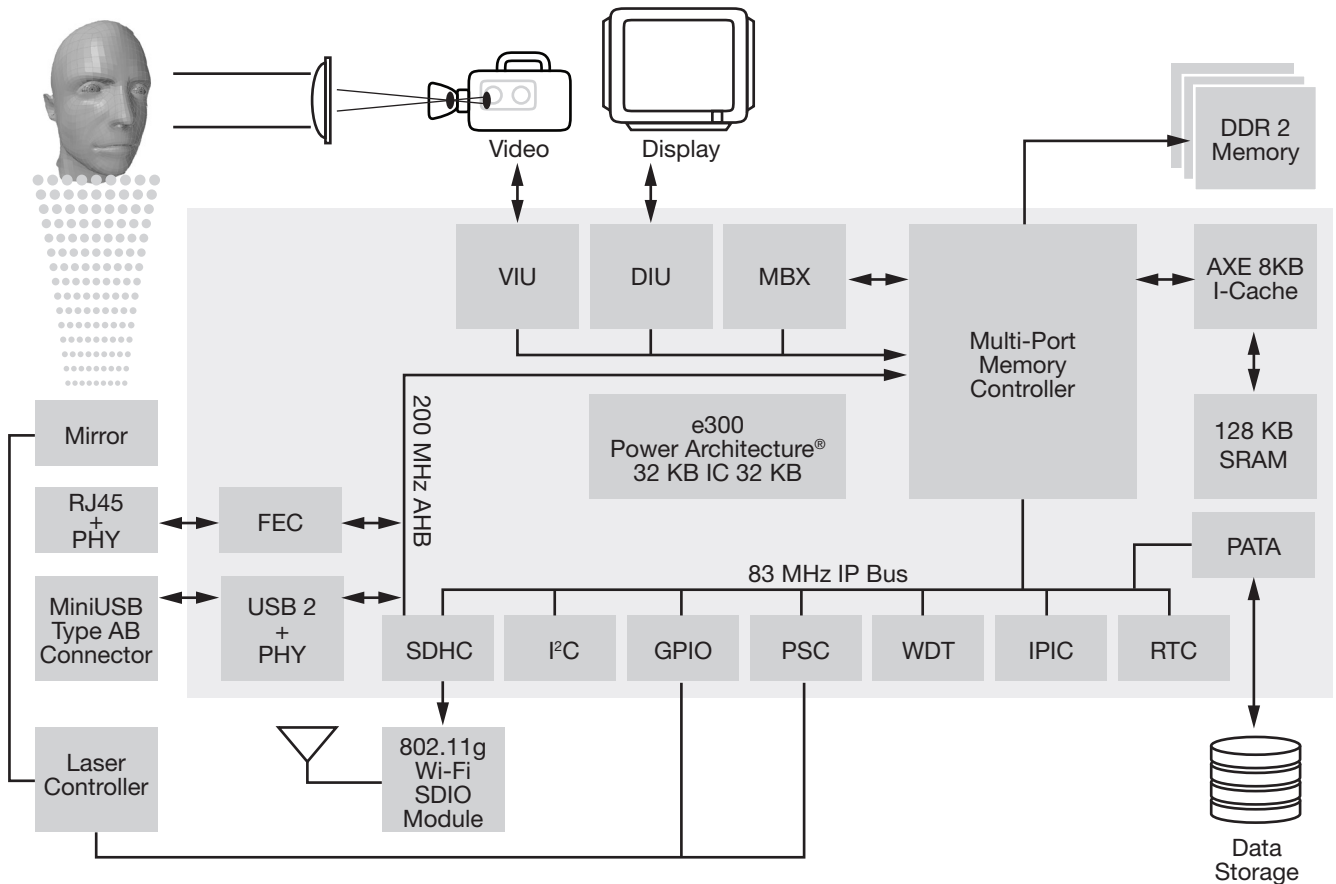

Figure 2

Image modeling is an important factor in a facial recognition system. Facial recognition, facial animation, video compression/coding, 3-D games, facial expression recognition, human action recognition for surveillance and object recognition are all image modeling outputs.

Users can store the display format and other useful information on a hard disk. The MPC5121e's PATA block offers two operation modes (PIO and DMA mode) that can be active at the same time.

A facial recognition system based on the MPC5121e processor can provide direct interface to display, video and storage using fewer components. The Power Architecture core and MBX core perform the post-processing for image reconstruction.

Designers can use MPC5121e's PSC and GPIO interfaces to control the laser's movement and intensity. The PSC can be used for serial communication between the laser unit and the MPC5121e processor while GPIO can work as on/off signals. Depending on the selected laser, a user can control its 180° circular movement with a timer, which turns the laser-positioning motor drive on and off to rotate the laser beam.

Real-time remote access and control of the facial recognition system from a central location is possible by using 100 Mbps Ethernet and a Wi-Fi interface.

In Figure 2, the VIU is a specific module where the video input is processed. It is used as a direct interface between the camera and the processor. The DIU is the module that controls the video output and LCD display. The laser control algorithms are processed by the MPC5121e. Some of the GPIOs and PSC are used as interfaces between the laser controller block and the e300 core.

## Laser Triangulation Schematic Diagram

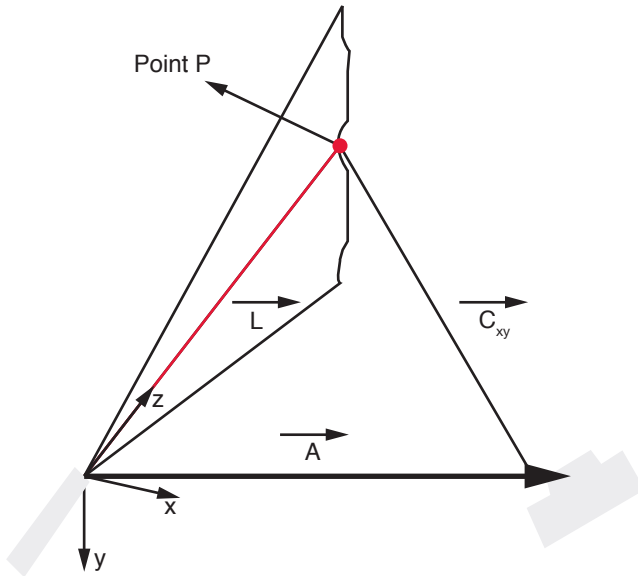

Figure 3

## General triangulation equations

The elements of the data acquisition system along with the point where the object is illuminated by the laser form a triangle of vectors (Figure 3). The objective of laser triangulation is to find the spatial coordinates of the illumination point (Point P) in a defined frame of reference.

Where,

L is the vector between the origin of the laser beam and point P  
 A is the vector between the origin of the laser beam and the optical center of the camera

C is the vector between the optical center of the camera and point P

The geometrical relation is expressed in the following vectorial equation:

$$\vec{L} = \vec{A} + \vec{C}_{xy} \quad (2)$$

From this equation, vector A as well as the directional cosines from the vector Cxy are known (see Camera Calibration section below).

Equation (2) expressed in spherical coordinates, where  $\varphi$  is the angle between the vector L and X-Y plane and  $\theta$  is the angle between the laser beam plane and X axis, is:

$$|L|\cos\varphi\cos\theta = A_x + Cxy_x \quad (3)$$

$$|L|\cos\varphi\sin\theta = A_y + Cxy_y \quad (4)$$

$$|L|\sin\varphi = A_z + Cxy_z \quad (5)$$

It is a non-linear system. Solving these equations is a problem of high computational cost. Nonetheless, by placing the reference system Z axis along the laser beam plane ( $\varphi = 0$ ), the system is reduced. The new system of equations is given by:

$$L_x = |L|\cos\varphi = A_x + Cxy_x \quad (6)$$

$$0 = A_y + Cxy_y \quad (7)$$

$$L_z = |L|\sin\varphi = A_z + Cxy_z \quad (8)$$

The analytic solution of the set of equations (6) to (8) is given by:

$$L_x = |L|\cos\varphi = A_x + |Cxy|\alpha \quad (9)$$

$$|Cxy|\gamma = -\frac{A_y}{\beta} \quad (10)$$

$$L_z = |L|\sin\varphi = A_z + |Cxy|\gamma \quad (11)$$

...where  $\alpha$ ,  $\beta$ ,  $\gamma$  are the directional cosines of the vector Cxy, in the laser's frame of reference.

These vector components are found using the camera's intrinsic and extrinsic parameters. Because of the importance of the camera location and its space orientation, it is necessary to find a transformation matrix. In general, the elements of a transformation matrix are the angles between each unitary vector from the original frame to the new frame. If both frames fit in one common axis, then the parameters are simplified in just one angle, as illustrated in Figure 4. This is the case for this application.

## Parameter of the Camera's Transformation Matrix

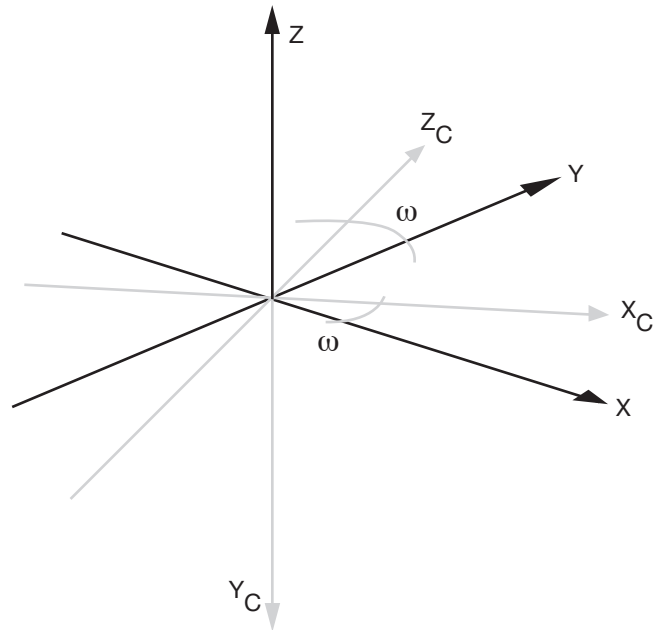

Figure 4



The parameter in Figure 4 is represented in the following transformation matrix:

$$\begin{bmatrix} \alpha \hat{x} \\ \beta \hat{y} \\ \gamma \hat{z} \end{bmatrix} = \begin{bmatrix} \cos\omega & 0 & \sin\omega \\ -\sin\omega & 0 & \cos\omega \\ 0 & -1 & 0 \end{bmatrix} = \begin{bmatrix} \alpha_c \hat{x}_c \\ \beta_c \hat{y}_c \\ \gamma_c \hat{z}_c \end{bmatrix} \quad (12)$$

Replacing (12) into (9) to (11), the system becomes:

$$L_x = |L| \cos\varphi = A_x + |Cxy| [\alpha_c \cos\omega + \gamma_c \sin\omega] \quad (13)$$

$$|Cxy_y| = -\frac{A_y}{\gamma_c \cos\omega - \alpha_c \sin\omega} \quad (14)$$

$$L_z = |L| \sin\varphi = A_z + |Cxy| [-\beta_c] \quad (15)$$

Because the laser beam path projects a line on the exploration surface, a rotating mirror is used to project the line along this surface (in this case a human face). This implies a mobile frame of reference in the laser beam, which then means the information needs to be referenced to a fixed system. In general, a mobile frame has translation and rotational components. Conventional transformations are inherently complex and difficult to drive. A very good alternative is to use a homogeneous transformation matrix. This is a block matrix that separates rotations and translations in two isolated partitions.

$$\begin{bmatrix} L_x \\ 0 \\ L_z \\ 1 \end{bmatrix} = T(\psi)_{4 \times 4} \begin{bmatrix} r_u \\ r_v \\ r_w \\ 1 \end{bmatrix} \quad (16)$$

If the reference system is located in the laser, the origin is defined as OUVW and the fixed system of reference as OXYZ, and  $(r_u, r_v, r_w)^T$  is the triangulated point  $(0, L_x, L_z)^T$ , using equations (13) to (15). Transformation matrix T describes, in general, the dynamics of the mobile mirror frame in a partition of rotation and a partition of translation.

$$T(\vartheta, \phi, \psi, x, y, z)_{4 \times 4} = \left[ \begin{array}{c|c} \gamma_{3 \times 3}(\vartheta, \phi, \psi) & \bar{T}_{3 \times 1}(x, y, z) \\ \hline 0_{1 \times 3} & 1_{1 \times 1} \end{array} \right] \quad (17)$$

Where,

$\gamma_{3 \times 3}$  is the rotation partition

$\bar{T}_{3 \times 1}$  is the translation partition

$\psi$  is the angle of rotation of the mobile mirror on the z component of the fixed frame

## Camera calibration

The objective of calibrating the 3-D laser scanning is to find the parameters of the triangulation equations (13) to (15). Those parameters are the vector A, the directional cosines of the vector Cxy and the parameters of the homogeneous transformation matrix T.

Although there are various ways to model a camera, in computer vision the pinhole model is often preferred because of its simplicity.<sup>[1]</sup> Finding the parameters of the model is a problem of optimization, specifically a parameter estimation problem. However, it is possible to find several algorithms that solve the problem in an iterative way.<sup>[2]</sup> It is important to take into consideration that image deviations in cameras are founded in lateral extremes due to chromatic and radial distortion in the lenses. Many calibration techniques omit these deviations for simplicity.

## Output

After digitizing the model, the output files can be manipulated using OpenGL-ES and displayed using an embedded controller, such as the MPC5121e processor. [See application note “3-D Graphics on the ADS512101 Board Using OpenGL ES” at [www.freescale.com](http://www.freescale.com) (search for AN3793)]

All the digitized points can be stored in a data base. For face recognition, these points are the comparison parameters that are different for every face scanned. Traditional techniques are based on extracting landmarks, or features, from a two-dimensional (2-D) image of the subject's face. These features are affected by changes in lighting, relative position and perspective variations. Some of these traditional techniques are based on the Eigenface method, neural networks or hidden Markov models. These techniques are very complex and expensive.

## Application and Driver Tools and Software

| ID                    | Description   | Software and Tool Type                      | Vendor                  |
|-----------------------|---|---|-------------------------|
| CW-MOBILEGT           | Integrated tool suite environment for mobileGT® applications. *Board support packages are offered free of charge, as-is.  | IDE: debug, compile and build tools         | Freescale               |
| KINETIC ECG ALGORITHM | The Kinetic ECG Algorithm provides signal processing and interpretation of the ECG waveform, thereby aiding health care professionals in assessing cardiac parameters | Protocol stacks and middleware              | Monebo                  |
| ADS512101             | MPC5121e, ADS5121, Mini-ITX, USB, audio, video, Ethernet, ATA, secure digital, automotive, consumer, industrial, portable   | Evaluation/development boards and systems   | Silicon Turnkey Express |
| MPLUS5121             | MPC5121e, Mini-ITX, Media5200, LCD, Ethernet, PATA, SATA, CAN, DVI, mobileGT, telematics, automotive, ADS512101, graphics   | Hardware components                         | Silicon Turnkey Express |
| MBX-SDK               | Available from FAE and marketing team   | Software development kit based on Linux® OS | Open Source             |

Table 1

On the other hand, the 3-D facial recognition system measures the positions of different points on a face and uses this information to create a 3-D surface image that contains the distinctive features of a specific face. The principal advantage of 3-D facial recognition is that it can identify a face from a number of viewing angles. In addition, it is not affected by changes in lighting as are the traditional techniques mentioned previously.

## Tools and software

For developing applications and drivers, Freescale and its partners provide the tools and software listed in Table 1. Soon, additional drivers are expected to be available from other third-party vendors.

## Conclusion

A new facial recognition technology based on Freescale's MPC5121e processor can provide a low-cost solution to help ensure public safety. The MPC5121e processor is a multi-featured solution that can help designers transform their ideas into reality, turning a big box facial recognition system into a compact, low-cost device for security applications.

To learn more about the MPC5121e processor, visit [www.freescale.com/mobilegt](http://www.freescale.com/mobilegt) or contact your local FAE. (Reference manual URL: [www.freescale.com/32bit](http://www.freescale.com/32bit))

## References

- [1] "Multiple View Geometry in Computer Vision," Richard Hartley and Andrew Zisserman, Second Edition, Cambridge University Press, March 2004
- [2] Applied Mathematics and Computation ISSN:0096-3003, Rudolf Scitovski, Marcel Meler

Deepak V. Katkoria is an IMT application engineer, formerly with Freescale Semiconductor. He has his degree in engineering from Pune University. While at Freescale, Deepak supported the MPC5200B and MPC5121e product families focusing on graphic support. Alberto Arjona Cabrera (Dmitri XIII) is a university professor and Freescale application engineer in Guadalajara, Mexico. Throughout his Freescale career he submitted several mathematical algorithms related to computer vision and signal processing applications. He received a master of science degree with a control theory specialty and has previously served as a captain in the Mexican Air Force.

Dugald Campbell

# Making Industrial Systems Safer

## Meeting the IEC 60730 standards

### Introduction

With the introduction of the International Electrotechnical Commission's IEC 60730 standards series, household appliance and industrial control manufacturers now have to consider introducing new design enhancements to their automatic electronic controls that ensure their component's safe and reliable operation.

IEC 60730 standards series on automatic electrical controls for household and similar use, Part 1, is one of many standards used by large appliance manufacturers. IEC 60730 is also referenced by other standards for other systems, such as boiler ignition systems (EN 297) and medical electrical equipment (IEC 60601), that cover general requirements for basic safety and essential performance. For details on IEC specifications, visit [www.iec.ch](http://www.iec.ch).

IEC 60730 discusses mechanical, electrical, electronic, environmental, endurance, EMC and abnormal operation of AC appliances. IEC 60730 Annex H: Requirements for Electronic Controls, specifically relates to microcontrollers (MCUs), detailing new test and diagnostic methods to ensure the safety of embedded control hardware and software for automatic systems. Its focus is to provide measures to ensure that the embedded software design functions safely and reliably if a fault condition occurs within the system's sub-components, such as CPU, memory, interrupts, program counter, communication interfaces and software program flow.

Today the majority of automatic electronic controls use single-chip MCUs (microprocessors with embedded memory and input/output peripherals). Manufacturers develop real-time embedded software that executes within the MCU and provides the hidden intelligence that controls an electro-mechanical device. Measures detailed in IEC 60730 are critical to help ensure that such an electro-mechanical device will not be hazardous to users.

IEC 60730/EN 60335 segments automatic control products into three different classifications:

**Class A:** Not intended to be relied upon for the safety of the equipment

**Class B:** To prevent unsafe operation of the controlled equipment

**Class C:** To prevent special hazards

Class A controls are deemed not hazardous if the software malfunctions, and thus IEC 60730 does not require the manufacturer to implement system checks.

A class B system likely has automatic controls where a possible hazard could occur and result in harm to a human being. Generally, the controls are characterized by how the class B system is implemented and if the critical safety system features some form of redundancy (in hardware and/or software).

#### Class B System That Ensures the Motor Will Not Overheat

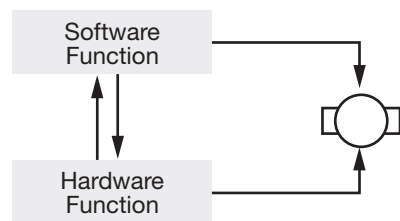

Hardware PTC monitors temperature. Software also monitors motor current. If one function fails the other ensures safe operation.

Class B—a fault occurring in a safety-critical software routine will not result in a hazard due to another software routine or redundant hardware intervening.

Figure 1

If the automatic control relies on a specific safety function and there is no redundancy, then the system will likely be deemed class C. If the automatic controls directly control an explosive substance, such as gasoline, the system will be deemed class C.

## Class C System That Ensures No Overheating of a Motor

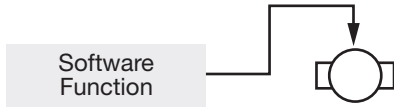

Class C—a fault occurring in a safety-critical software routine will result in a hazard.

Figure 2

The various components of an embedded system that must be tested are summarized in Table H.11.12.7. of IEC 60730 Annex H. For each of the listed class B and class C components, optional measures are given for the manufacturer to deploy within the automatic system.

## Class B systems

Table 1 summarizes the required components that need to be tested and monitored to ensure the system meets class B specifications.

### Class B Components That Need Testing and Monitoring

|    | Class B 60730 components required to be tested on electronic control (see Table H.11.12.7) | Fault error                            |
|----|--|--|
| 1  | 1.1 CPU registers  | Stuck at                               |
| 2  | 1.3 CPU program counter  | Stuck at                               |
| 3  | 2. Interrupt handling and execution  | No interrupt or too frequent interrupt |
| 4  | 3. Clock   | Wrong frequency                        |
| 5  | 4.1 Invariable memory  | All single bit faults                  |
| 6  | 4.2 Variable memory  | DC fault                               |
| 7  | 4.3 Addressing (relevant to variable/invariable memory)                                    | Stuck at                               |
| 8  | 5. Internal data path  | Stuck at                               |
| 9  | 5.2 Addressing   | Wrong addr                             |
| 10 | 6. External communications   | Hamming distance 3                     |
| 11 | 6.3 Timing   | Wrong point in time/sequence           |
| 12 | 7. I/O periphery   | Fault conditions specified in H.27     |
| 13 | 7.2.1 Analog A/D and D/A converters  | Fault conditions specified in H.27     |
| 14 | 7.2.2 Analog multiplexor   | Wrong addressing                       |

Table 1

CPU registers can be monitored by using a periodic test routine that writes a 0xAA pattern followed by a 0x55 pattern to verify no register bits are stuck at a 1 or 0 state.

A CPU program counter can be similarly tested with a 0x55/0xAA pattern by placing small routines at addresses 0x5555.. and 0xAAA.. that have return from subroutine instructions (RTS). The CPU should execute these routines and then examine the contents in the stack pointer.

Interrupt handling and execution is verified by a method called independent time base monitoring. This requires a regular periodic check from a time base independent of the CPU clock. An example is having a real-time interrupt clocked by an independent 1 kHz oscillator that includes a check on token counters of all interrupts utilized. If any irregularity is discovered, then the CPU is forced into a routine that places the application in a safe state.

The clock or the CPU clock is also required to be checked by an independent time-base monitor. An independent clocked timer, such as a real-time interrupt, can be used to make timestamps at regular intervals from a CPU clocked timer. Additionally, Freescale MCUs feature a watchdog counter that is clocked by an independent time base. This feature provides an additional check if the CPU clock stops, ensuring that an asynchronous reset occurs to place the system in a safe state. Watchdogs that are clocked from the same source as the CPU cannot provide this protection.

For invariable memory (flash), the manufacturer is required to check for single bit faults, which can be performed using a modified checksum routine. The main issue here is that there is no common method or routine for deploying a modified checksum. Manufacturers have taken the approach of deploying the program memory's cycle redundancy checking (CRC) signatures because it is well understood and has a reliable mechanism for identifying single-bit errors. After all bytes have been read, each byte is run through a CRC calculation. Once that calculation is made, it can be compared to a "golden" CRC signature to verify no single faults exist. Freescale has created a hardware CRC engine that will provide a fast method of creating a 16-bit CRC. For small memory footprints, the CRC can be calculated in software within a reasonable time frame.

Variable memory (RAM) can be verified as having no DC faults by executing a periodic test using the well-known March C or March X test pattern. These March patterns (Figure 3) require a lot of execution time for most embedded systems, and the designer must segment the RAM into favorable sizes, checking each segment in sequence. Freescale has developed March C and March X tests for HCS08 and MC56F80xx controllers, which can help speed up the development of a class B system.

The March X pattern is a subset of March C where only steps 1, 2, 5 and 6 are executed, thus saving CPU execution time.

Components 4.3 addressing, 5.0 internal data path and 5.2 addressing (Table 1) are covered by implementing the above variable and invariable periodic test routines. 6.0 external communication refers to protocols that are used to interface with components external to the automatic control system, such as UART communication between a control board and a motor control board. There are several optional measures to ensure reliable communication, such as adding a 16-bit CRC to data

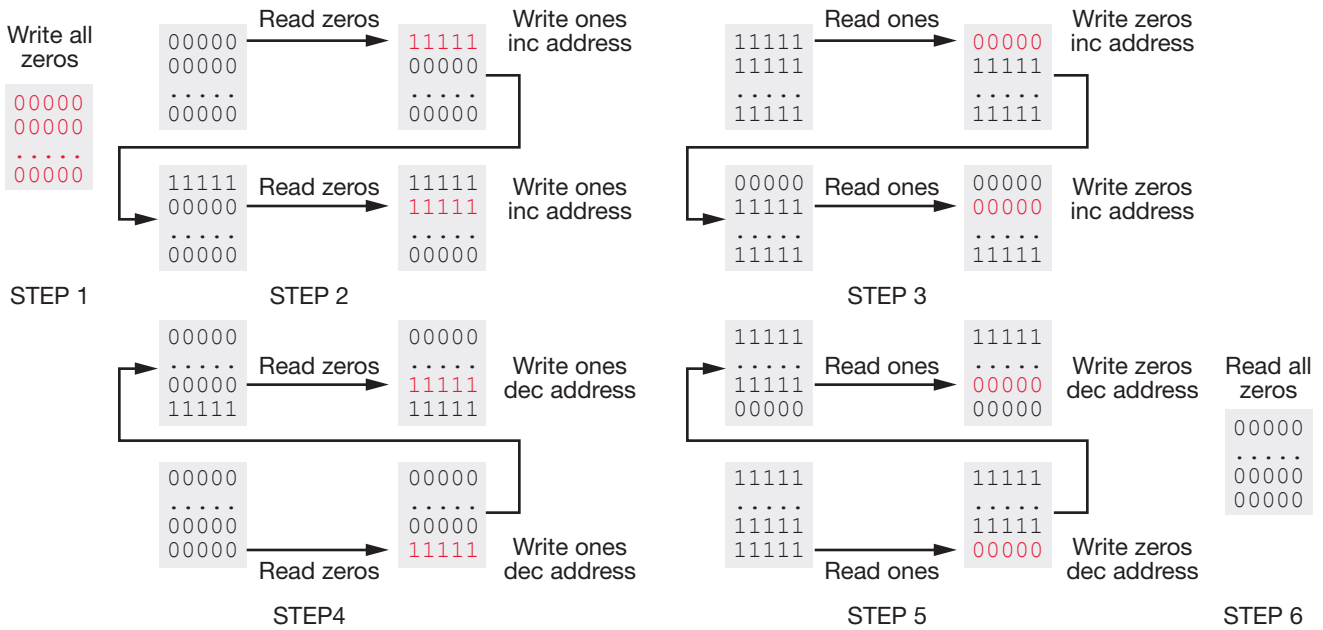

Figure 3

transferred via the communication port and transfer redundancy, which is simply sending data twice. A timing component, as in the wrong point in time, and sequence of external data exchanges can be reliably checked using independent time slot monitoring, the same as used for interrupts.

Components 7.0 periphery, 7.2.1 analog I/O and 7.2.2 analog multiplexers (Table 1) require the manufacturer to carry out plausibility checks prior to application use. These employ a number of techniques, including making upper/lower limits on ADC inputs, redundant ADC inputs to check multiplexer and short circuit and open circuit tests of adjacent pins to a safety-critical signal line.

Subjecting a system design to all of the measures described above will provide IEC 60730 Class B compliance.

## Class C systems

Table 2 summarizes the required components that need to be tested and monitored to ensure the system meets class C specifications.

For class C systems there is one additional component that needs to be tested and more stringent measures placed on four of the existing components. The additional component is 1.2 CPU instruction decoding and execution, which is required to check that the CPU is decoding the instructions used to perform the safety feature. Table H.11.12.7 of IEC 60730 Annex H provides three optional measures to test for this component:

- Dual CPU implementation with comparison
- Internal hardware detection
- Periodic self-test using equivalence class test

### Class C Components That Need Testing and Monitoring

|    | Class C 60730 components required to be tested on electronic control (see Table H.11.12.7) | Fault error                            |
|----|--|--|
| 1  | 1.1 CPU registers  | DC fault                               |
| 2  | 1.3 CPU program counter  | Stuck at                               |
| 3  | 1.2 CPU instruction decoding and execution   | Wrong decoding or execution            |
| 4  | 2. Interrupt handling and execution  | No interrupt or too frequent interrupt |
| 5  | 3. Clock   | Wrong frequency                        |
| 6  | 4.1 Invariable memory  | 99.6% coverage of all info errors      |
| 7  | 4.2 Variable memory  | DC fault & dynamic cross links         |
| 8  | 4.3 Addressing (relevant to variable/invariable memory)                                    | Stuck at                               |
| 9  | 5. Internal data path  | Stuck at                               |
| 10 | 5.2 Addressing   | Wrong addr                             |
| 11 | 6. External communications   | Hamming distance 4                     |
| 12 | 6.3 Timing   | Wrong point in time/sequence           |
| 13 | 7. I/O periphery   | Fault conditions specified in H.27     |
| 14 | 7.2.1 Analog A/D and D/A converters  | Fault conditions specified in H.27     |
| 15 | 7.2.2 Analog multiplexer   | Wrong addressing                       |

Table 2

## CPU instruction decoding and execution

Freescale Power Architecture® products, such as the MPC5510 family, have dual CPU cores that can execute simultaneously, and the execution results can be compared prior to executing a safety function. Freescale provides internal hardware detection through error code correction (ECC), which uses a form of parity when reading program instructions and can automatically correct single parity errors. This feature can be found on S12X family members, such as the MC9S12XE100, as well as the MPC5510 family, which has ECC on both flash and RAM memory.

For our 8-bit S08 CPU, Freescale has developed a CPU instruction test that can be executed prior to running power-up on the end application. This test routine requires approximately 2 KB of program memory, but it's modular, which allows removing tests for instructions that are not utilized by the safety application. Execution time for the full test is 3666 CPU BUS cycles (183.3 µs at 20 MHz).

TÜV SÜD has validated and certified this test routine to be IEC 60730-compliant, and the test routine is available for Freescale customers. Please contact your local Freescale representative to obtain free license and software information.

In addition to the extra component to be tested, there are four components of class C systems that require more stringent testing:

- CPU register test
- Variable memory (RAM)
- Invariable memory (flash)
- External communications

### Walking 1s Pattern for 8-bit Register

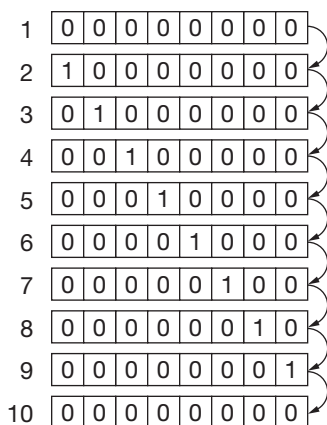

For each of the 10 steps the data is verified to ensure no DC faults.

CPU register test requires the manufacturer to check for DC faults on the CPU registers, which can be accomplished using a walking 1s and walking 0s pattern.

Figure 4 shows a walking 1s pattern on an 8-bit register. By executing this pattern and confirming the data at each step, all DC faults will be exposed. A walking 0s pattern is similar to the walking 1s pattern with all data inverted, and it should also be performed.

Variable memory (RAM) testing requires the same techniques as used for the CPU register (walking 1s and walking 0s to check for DC faults). For RAM arrays of >2 KB, executing such a test can be time consuming. However, the manufacturer can split the RAM array into small segments (32–128 bytes), and each RAM segment can be tested in sequence while executing the application. Note that the manufacturer will likely need to pause the application while it tests each application and disable interrupts to ensure no program variables are inadvertently corrupted.

Freescale has developed a walking 1s and walking 0s RAM test for the HC9S08AC60 MCU, which segments the RAM into 48-byte segments. This is modular software, however, and can be easily modified to support larger or smaller RAM arrays.

Invariable memory (flash) for class C systems requires the user to look for 99.6 percent coverage of all bits. This can be covered by ECC or by a 32-bit CRC. Optionally, redundant memory can be deployed where the CPU can periodically check that both arrays compare.

For external communications components meeting class C specifications, the manufacturer is required to implement either a 32-bit CRC to data transfers or deploy data redundancy, where the data is sent at least twice and the redundant data is modified in some form, such as inverting the second piece of data. Another option is to use comparison or redundant functional channels with comparison. By using two communications ports and sending the data on both ports, the software can compare the received data to ensure they match.

Figure 4



## Software

Freescale has developed periodic test routines for Freescale MCUs that users can deploy in their application code. These developed routines have each been certified by a certification body, such as VDE or TÜV SÜD, to meet IEC 60730 requirements.

### Certified IEC 6073-Compliant Freescale Developed Test Routines

| Class B                              | HCS08 | MC56F80xx |
|--------------------------------------|-------|-----------|
| CPU register stuck at                | •     | •         |
| Program counter stuck at             | •     | •         |
| Watchdog timerout test               | •     | •         |
| RAM March C test                     | •     | •         |
| RAM March X test                     | •     | •         |
| Flash CRC (software CRC calculation) | •     | •         |
| Flash CRC (hardware CRC engine)      | •     |           |
| Class C                              |       |           |
| CPU register DC faults               |       |           |
| CPU instruction test                 | •     |           |
| RAM walking 1s test                  | •     |           |
| RAM walking 0s test                  | •     |           |

Table 3

## Summary

Although these hardware and software safety features have been developed to help manufacturers meet the IEC 60730 standard, it is clear that these features are also needed in medical applications as determined by IEC 60601.

Freescale has developed hardware features, such as independent watchdogs, CRC engines, ECC and software periodic test routines to help manufacturers gain IEC 60730 compliance. These features are available on HCS08, MC56F80xx, S12X, ColdFire® and Power Architecture products, providing flexible options for the manufacturer based on the complexity and size of the automatic control system. Freescale is also developing enhanced hardware safety features for future products to help improve system software integrity and safety, which will be available in 2009 and beyond.

Dugald Campbell is an industrial systems solution engineer at Freescale Semiconductor. He has more than 20 years of experience in embedded microcontroller design in the consumer and industrial market. His recent focus has been on large appliance, medical and industrial safety applications.

Bogdan-Constantin Holmanu

## Wireless Sound Notification System for Visually Impaired Persons

### Introduction

According to a 2002 World health organization survey, there are more than 161 million visually impaired individuals worldwide<sup>[1]</sup>. Memorizing outside landmarks and inside room layouts, as well as using the touch sense to differentiate objects such as medicines and different tools and utensils, help the visually impaired navigate through everyday life. Their sense of hearing can also help a great deal. Through acoustic guidance, a person can estimate his or her motion and approximate the distance and positioning of a specific object. Technology breakthroughs, especially in wireless communication, can enable new products that can magnify the effectiveness of acoustic guidance to facilitate daily needs.

### The wireless connection

This paper proposes a system that enables a certain degree of acoustic support, such as guidance and object differentiating, for visually impaired individuals. This support can be achieved by using IEEE® 802.15.4 wireless-based platforms. The real advantage of the 802.15.4 solution is its low-power characteristics, which extend battery life and reduce maintenance costs. Acoustic support can be implemented using body-attached audio hardware and additional memory for message recording. The system is based on the 802.15.4 network data transfer service with link quality indication used to approximate the distance between two nodes in the wireless network.

### Hardware overview

The system consists of two types of devices (object and personal) that can interact through 802.15.4 wireless communication. Both devices are based on 802.15.4 platforms, with either an S08 microcontroller (MCU) core or ARM® MCU core and a 2.4 GHz 802.15.4 radio frequency (RF) transceivers.

The platforms used for object devices must have additional audio hardware, from a simple MCU design with integrated analog audio hardware to a DSP-enabled platform with enough memory for voice recording and increased processing capability. For instance, a DSP-enabled object device could wirelessly

communicate with a PC through an 802.15.4 connection to download critical information. This data could then be converted to speech by a text-to-speech (TTS) converter to provide information to the visually impaired. To implement this feature, an additional support person is required.

### Hardware Block Diagram

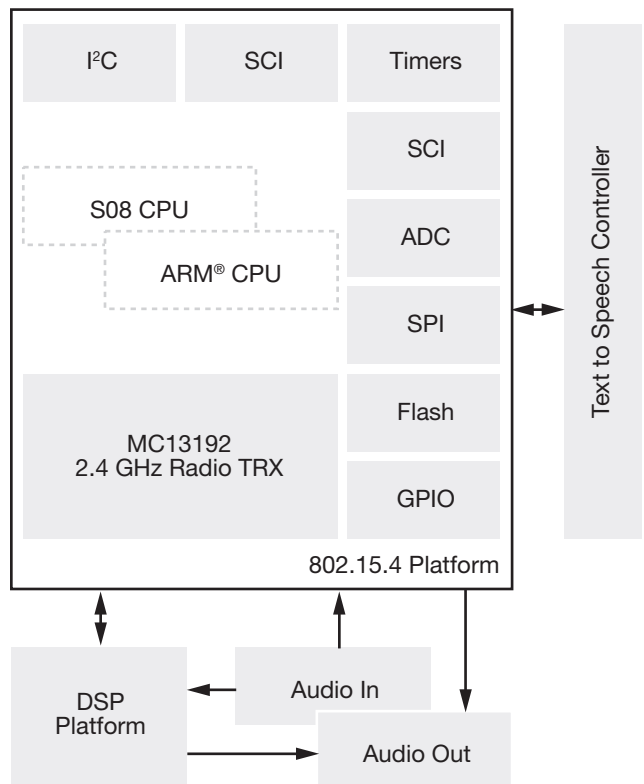

Figure 1

### Software overview

The system has to be able to notify a visually impaired person whenever he or she is within the desired proximity of an object. To do this, the software must deliver a set of system functions. Two modes of operation can be designed for both object and personal devices—a paired mode, where two devices are programmed to recognize each other, and a broadcast mode.

Pair mode is a good option for indoor use because it prevents interference from other 802.15.4 systems in the area, ensuring the integrity of the wireless network. Broadcast mode must integrate the broadcast service with an application-specific operation used for device recognition. This operation can be implemented using a simple message-based handshake. With broadcast mode, it is possible to deploy a large-scale outdoor sound notification system for visually impaired persons that provides acoustic support for applications such as traffic lights or road and walkway signage. It can also be used indoors for large public institutions, such as libraries or hospitals. Broadcast systems need a constant power source and must meet several mechanical and electrical design requirements. The system must be able to filter other spectrums' radio waves and not allow harmful electrical noises to damage the hardware. In addition, the outdoor device must be weatherproof to protect the hardware from the elements.

For both object and personal devices, the software application can be built over the 802.15.4 media access control (MAC) software libraries and platform-specific driver modules. The applications require the full function device (FFD) MAC library<sup>[3]</sup> to be implemented on both types of devices. The full function device non-beacon (FFDNB) library includes all MAC features and requires 24.2 kilobytes code size and 426 bytes of RAM memory for the S08 platform. The MAC library for the ARM platform is put directly into 44 kilobytes of ROM and contains all MAC FFD functionality. All MAC libraries can be downloaded at [www.freescale.com](http://www.freescale.com)<sup>[3]</sup>. The MAC stack can be accessed using the BeeKit™ Wireless Connectivity Toolkit, a software tool that can generate framework applications, including the MAC stack and platform components for all of Freescale's 802.15.4 solutions.

The personal device application software can be built on top of the MAC library and software platform components. These components contain the drivers for the S08 or ARM MCU peripherals, as well as the typical services required by any application, such as serial communication, timers and non-volatile storage. They must also have the same API across

all hardware platforms. The drivers and platform components are delivered with the 802.15.4 software solution as part of the MCU-specific project.

Before accessing MAC services and platform components, initialization routines must be called. The application's major task is to send broadcast messages at predefined times to notify its presence to object devices. The interval between broadcast messages must be short enough to cover even the fastest movement that a person can make. To ensure this, the time interval should be less than a tenth of a second. Smaller time intervals, however, consume more power, so an adaptive time interval can be used to manage the power consumption. The interval is greater when no confirmation is received for notification messages and smaller when confirmations are received.

The broadcast message is sent using the data request service. The 802.15.4 MAC has long address and short address data transmitting modes. In addition to the device address, a personal area network ID (PAN ID) must be specified into the data service's parameters. A broadcast message is sent using an 0xFFFF value for both the PAN ID and the short address. After sending the broadcast message, the system will immediately enter a low-power mode to extend battery life and exit that mode after a set amount of time. Alternatively, instead of using a clock-to-cycle low-power mode, a personal device could be designed with a motion sensor that would wake the device out of low-power mode only when circumstances dictated that the device must send another broadcast message. This feature can be used to save battery power when the person is not moving or is not carrying the device. In Figure 3, the blocks for this feature have dashed borders.

The battery lifetime can be estimated during the system's design stage using the experimental data published at [www.freescale.com](http://www.freescale.com)<sup>[4]</sup> in the white paper, *Ultra-Low-Power Wireless Designs for Real-Time Communication* (search for "ultra-low-power wireless design"). The experiment setup includes a demo board with the MC9S08QG8 16-pin 8-bit MCU, MMA7260QT triaxial accelerometer and the MC13191 802.15.4 transceiver with three power modes that can be accessed from the application through the power library. The white paper cites power consumption numbers for the different power states of each board component. Using the Battery Life Versus Packets/sec chart from the paper, battery lifetime can be estimated for a personal or object device. For example, if the device broadcasts packets five times per second, the battery lifetime is about 25 days. Using an adaptive time interval, the system's battery lifetime depends on device usage modes.

The object device software also must be built using the 802.15.4 MAC library and platform components. After platform startup, the MAC stack and platform initialization calling routines are the first two steps. The application must be able

### Application Message-Based Handshake Chart

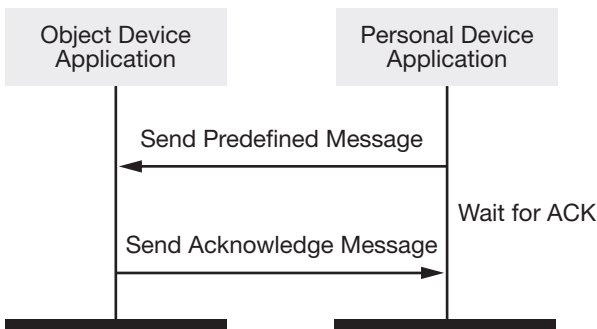
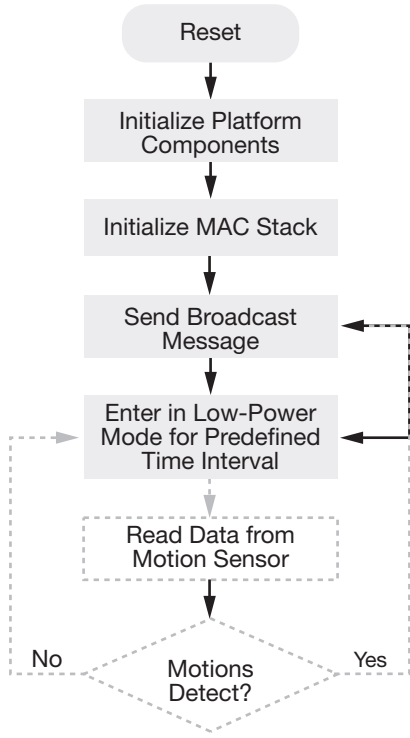
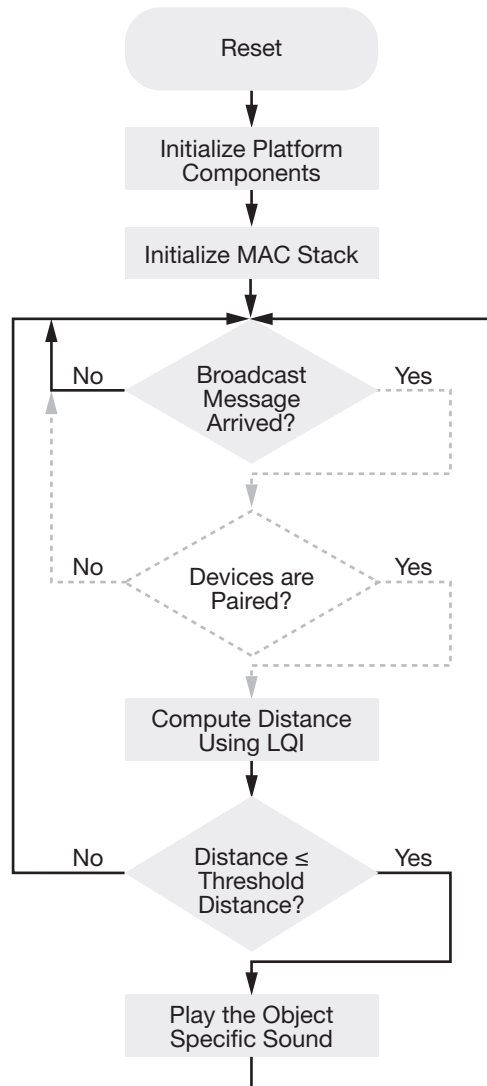

Figure 2

**Figure 3**

to detect broadcast message reception. The next step in the software application is optional and uses a pairing mechanism. If this pairing is used, and the devices were previously paired, the application must compute the distance between devices. This is achieved using the link quality indicator (LQI) of the data transfers.

Freescale has published an application note, MC1319x Range Performance<sup>[2]</sup>, which investigates the correlation between transceiver power and the distance between two 802.15.4-enabled devices. The application note can be downloaded from [www.freescale.com](http://www.freescale.com) (search for “AN2902”). If the distance is lower than a predefined proximity distance, the device has to play a specific object sound. If the notification is simple, like buzzer sounds, the application can use the driver routines for the background platform with a framework application generated with the BeeKit Wireless Connectivity Toolkit<sup>[3]</sup>. If the platform can enable voice recording and voice rendering, the software must include additional modules for communication with a DSP platform.

**Figure 4**

## Conclusion

The wireless sound notification system can significantly improve the quality of life for many visually impaired people. Freescale offers low-cost, robust, complete hardware and software platforms for the 802.15.4 marketplace, enabling system providers to develop compelling and competitive solutions, such as the one presented in this article. Freescale offers two main hardware solutions: an S08 MCU-based solution and an ARM7™ MCU-based solution. MC1321x system in package (SiP) is Freescale’s second-generation ZigBee® platform, which incorporates a 2.4 GHz radio frequency transceiver and an 8-bit S08 microcontroller<sup>[5]</sup>. The MC13224V is a third-generation ZigBee platform that incorporates the radio transceiver with a 32-bit ARM7 core-based MCU with hardware acceleration for both the 802.15.4 MAC and AES security<sup>[6]</sup>. Both platforms are available with 802.15.4 MAC and ZigBee stacks.

## MC1321x System Level Block Diagram

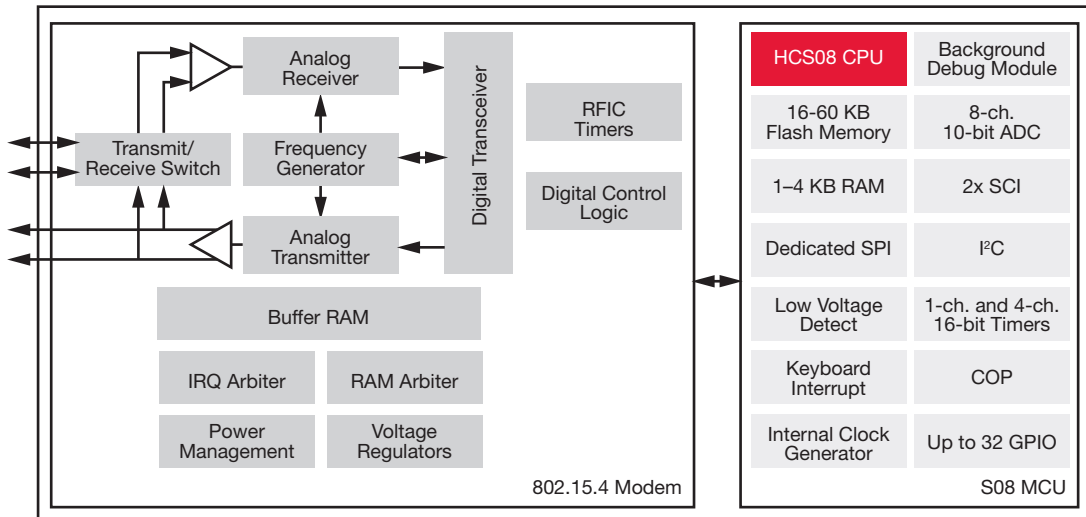

Figure 5

## MC13224V Block Diagram

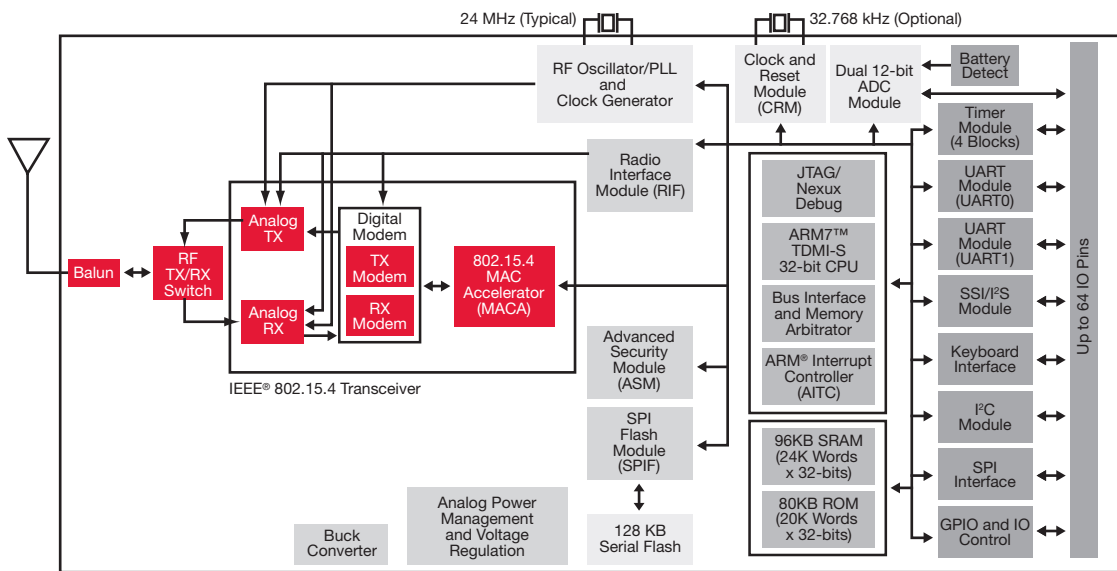

Figure 6

## References

- [1] Magnitude and causes of visual impairment (World Health Organization), [www.who.int/mediacentre/factsheets/fs282/en/](http://www.who.int/mediacentre/factsheets/fs282/en/)
- [2] AN2902 MC1319x Range Performance Application Note
- [3] BeeKit Wireless Connectivity Toolkit, [www.freescale.com/webapp/sps/site/prod\\_summary.jsp?code=BEEKIT\\_WIRELESS\\_CONNECTIVITY\\_TOOLKIT&fsrch=1](http://www.freescale.com/webapp/sps/site/prod_summary.jsp?code=BEEKIT_WIRELESS_CONNECTIVITY_TOOLKIT&fsrch=1)
- [4] Ultra-Low-Power Wireless Designs for Real-Time Communication, [www.freescale.com/webapp/sps/site/overview.jsp?code=784\\_LPBBLLWPWRWRLSS&fsrch=1](http://www.freescale.com/webapp/sps/site/overview.jsp?code=784_LPBBLLWPWRWRLSS&fsrch=1)
- [5] MC1321x Technical Data Document
- [6] MC1322x Product Preview Document

Bogdan-Constantin Holmanu graduated with a computer science degree from Technical University of Iasi, Romania in 2008, and joined Freescale Semiconductor Romania in 2008 in the wireless connectivity organization as part of the MAC and platform team. As part of a four-student team he won second prize at Microsoft Imagine Cup competition, Embedded Development section, with a Networked Braille Learning Environment project.

# 97

## Freescal Semiconductor

### Family product summaries

---

*Beyond Bits IV* presents many new and innovative ways to implement modern electronic technology. It's meant to spark your imagination so that you can develop products that break new ground in form and functionality. Let us help you find the semiconductor platforms you need to build your new designs. We have a number of online product summary guides that can match Freescale hardware, software and tools with your next project.

#### **Wireless Connectivity Product Summary**

[www.freescale.com/files/wireless\\_comm/doc/fact\\_sheet/ZIGBEEMCUPS.PDF?fsrch=1](http://www.freescale.com/files/wireless_comm/doc/fact_sheet/ZIGBEEMCUPS.PDF?fsrch=1)

#### **8-bit Product Summary**

[www.freescale.com/files/microcontrollers/doc/fact\\_sheet/8BITCIPRODMPPFS.pdf](http://www.freescale.com/files/microcontrollers/doc/fact_sheet/8BITCIPRODMPPFS.pdf)

#### **32-bit Product Summary**

[www.freescale.com/files/microcontrollers/doc/brochure/BRCOLDFIREPRODSUM.pdf](http://www.freescale.com/files/microcontrollers/doc/brochure/BRCOLDFIREPRODSUM.pdf)

#### **DSC Product Summary**

[www.freescale.com/files/industrial/doc/brochure/DSCPRDCTSMRY.pdf](http://www.freescale.com/files/industrial/doc/brochure/DSCPRDCTSMRY.pdf)





# It's a prescription for success.

## Freescale Medical Solutions

---

Freescale offers a comprehensive line of medical solutions from analog to sensors in addition to ultra-low-power MCUs, highly integrated MPUs, medical-specific software, reference designs, white papers, application notes and more. But we don't stop there. We've established a Medical Center of Excellence staffed by design engineers and clinicians to provide you with an unprecedented level of support and expertise. We're committed to helping the medical device community deliver lower power, more innovative designs that can get to market faster and deliver healthier margins.



Explore the possibilities at [freescale.com/medical](http://freescale.com/medical)

