

Installing Chassis in a Cabinet

INSTALLATION INSTRUCTION



NOTICE

The information contained in this document is believed to be accurate in all respects but is not warranted by Mitel Networks™ Corporation (MITEL®). Mitel makes no warranty of any kind with regards to this material, including, but not limited to, the implied warranties of merchantability and fitness for a particular purpose. The information is subject to change without notice and should not be construed in any way as a commitment by Mitel or any of its affiliates or subsidiaries. Mitel and its affiliates and subsidiaries assume no responsibility for any errors or omissions in this document. Revisions of this document or new editions of it may be issued to incorporate such changes.

No part of this document can be reproduced or transmitted in any form or by any means - electronic or mechanical - for any purpose without written permission from Mitel Networks Corporation.

TRADEMARKS

The trademarks, service marks, logos and graphics (collectively "Trademarks") appearing on Mitel's Internet sites or in its publications are registered and unregistered trademarks of Mitel Networks Corporation (MNC) or its subsidiaries (collectively "Mitel") or others. Use of the Trademarks is prohibited without the express consent from Mitel. Please contact our legal department at legal@mitel.com for additional information. For a list of the worldwide Mitel Networks Corporation registered trademarks, please refer to the website: <http://www.mitel.com/trademarks>.

© Copyright 2017, Mitel Networks Corporation

All rights reserved

1 INTRODUCTION

MX-ONE is a communication solution for enterprises. MX-ONE integrates voice communication in fixed and mobile networks for public as well as private service. MX-ONE can be integrated into an existing Local Area Network (LAN) infrastructure. MX-ONE supports both IP telephony and functions found in classic circuit-switched PBXes (Private Branch Exchanges).

1.1 SCOPE

This document describes the MX-ONE Cabinet Installation in a detailed way. It is aimed for customers doing new installation. For other parts of the Installation see:

- Installation preparation and Earthing, 19/1531-ASP11301
- Installation boards and Cabling, 21/1531-ASP11301

1.2 TARGET GROUP

The target group for this document is personnel involved in installing the MX-ONE.

1.3 PREREQUISITES

This section lists requirements that must be fulfilled before the installation starts.

1.3.1 ELECTRICAL CONNECTIONS

Installation procedures involving connection of power cables, batteries and earthing must be performed according to local regulations.

1.3.2 SAFETY

All personnel involved in installation must read and understand the safety instructions prior to installation, see the description document for *SAFETY*.

2

INSTALLING CABINET

This section describes a full installation of hardware components in the BYB 501 cabinet. The recommended installation order is from the bottom of the cabinet to the top.

Depending on the configuration, some pieces of hardware can be pre-installed. Therefore, some installation steps may be irrelevant. In that case, ignore the irrelevant step and proceed to the next one.

It is recommended to install the hardware at the cabinet locations described in the instructions below. Although not recommended, it is possible to change the hardware placement in the cabinet. In that case, the following constraints must be regarded:

- The batteries must be placed at the lowest position in the cabinet.
- The fan unit must always be installed directly above the subracks.
- Two subracks must be mounted closely, one above the other.

Note: The following instructions describe a hardware installation in the BYB 501 cabinet. When installing the hardware in other type of cabinets, refer to manufacturer instructions.

2.1

OVERVIEW

This section describes the hardware components in the MX-ONE, their functions, and technical details as dimensions and weights.

The hardware components in the MX-ONE are mounted in 19-inch cabinet: the BYB 501 cabinet, the standard cabinet (locally sourced).

This document describes installation of hardware in the BYB 501. Most of the instructions are also relevant for installation in other 19-inch cabinets.

The hardware components include a variable number of power units, batteries, subracks with extension boards, fan units, Media Gateways, and servers. The number of components and their location in the cabinet vary according to customer needs.

For an example of an MX-ONE cabinet and its main hardware components, see Figure 1:MX-ONE Cabinets on page 5.

The components in the figure are:

- A** MX-ONE cabinet, BYB 501
- B** Standard cabinet (locally sourced)
- C** Battery string
- D** AC/DC unit
- E** DC/AC inverter (locally sourced)
- F** Subrack MX-ONE Lite
- G** Subrack MX-ONE Classic
- H** Fan unit
- I** Servers for the MX-ONE and MX-ONE Messaging
- K** MX-ONE Server

For information on technical details for the hardware components, see Table 1 Size, Weight, and Voltage of MX-ONE Hardware on page 6.

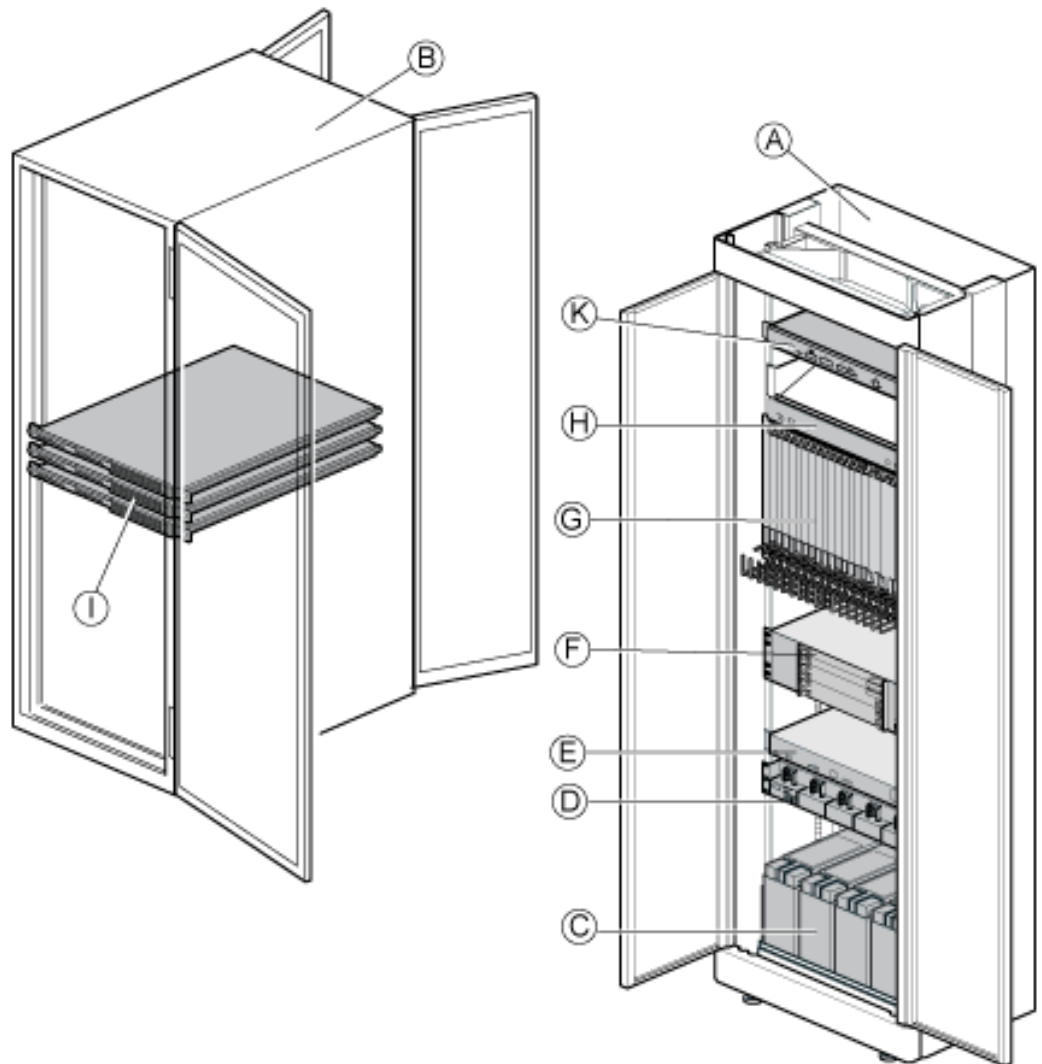

Figure 1: MX-ONE Cabinets

Table 1 Size, Weight, and Voltage of MX-ONE Hardware

Pos	Component	Product Number	Width, height, and depth (mm)	Weight (kg)	Input Voltage	Output voltage	Height (U) ²⁾	Height (M) ³⁾
A	BYB 501 cabinet		600 x 1,800 x 400	75				
B	Standard cabinet	Locally sourced						
C	Battery 31 Ah (4 battery blocks)	BKB 201 003/1	425 x 159 x 280	45		-48 V DC	4	7.2
	Battery 62 Ah (4 battery blocks)	BKB 201 003/2	425 x 264 x 280	82		-48 V DC	6	10.8
D	AC/DC Unit	51305282	440 x 90 x 350	12.8 - 14.6 ¹⁾	90 - 250 V AC	-48 V DC	2	4
E	DC/AC Inverter	Locally sourced						
F	MX-ONE Lite (3U-chassis)	87L00039 BAA-A	440 x 130 x 235	3.9 ¹⁾	-48 VDC or 115/240 VAC		3	5.4
G	MX-ONE Classic LBP22 (7U)	BFD 761 40/1	450 x 310 x 315	6.6 – 14.0 ¹⁾	-48 V DC		7	12.6
H	Fan unit	BFD 509 08/4	435 x 50 x 240	4.5	-48 V DC		1.2	2.2
I	Standard Server	KDU 137 xxx/x	463 x 44 x 693	23	100 – 240 V AC		1	not for BYB 501
K	MX-ONE 1U chassis	87L00032 BAA-A	440 x 45 x 220	2.2 ¹⁾	-48 VDC or 115/240 VAC		1	2

¹⁾ Depending on configuration.

²⁾ U = 44.45 mm = 1.75 inches

³⁾ M = 25 mm = 0.98 inch

For information about power dissipation and power consumption, see the description for *POWER DISSIPATION*.

The following flow diagram shows the installation procedure step-by-step. See Figure 2:Workflow for the MX-ONE Hardware Installation on page 7.

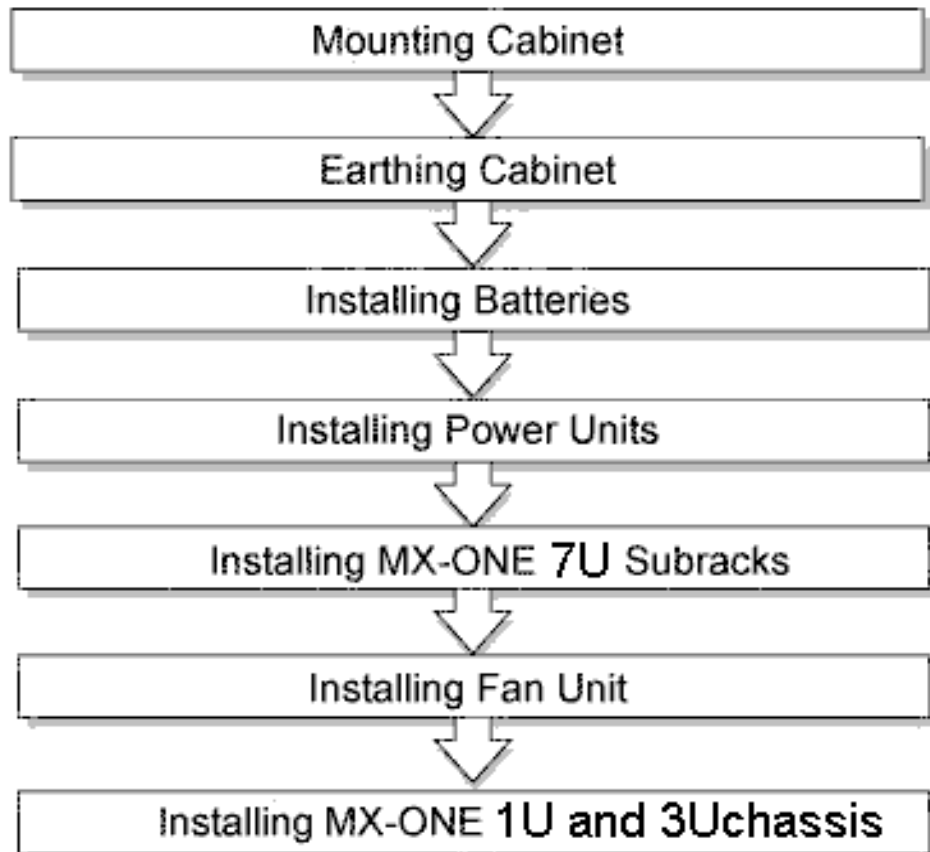

Figure 2: Workflow for the MX-ONE Hardware Installation

2.2 MOUNTING CABINETS

This section describes mounting of the cabinets. The instructions focus on the BYB 501 cabinets. For installation of the standard server cabinet, see the manufacturer instructions.

After this installation phase, all cabinets are positioned, fastened, leveled, and anchored to the site floor.

2.2.1 UNPACKING

When unpacking the cabinet, perform the following steps:

1. Open the cabinet case using the Vikex opener.
2. Lift the cabinet using a cabinet hoist or at least four people.
3. Place the cabinet on the floor in an upright position. Take extra care to avoid the cabinet from tipping over, as it is not yet secured to the floor.
4. Remove the plastic wrapping from the cabinet.
5. Move the cabinet to its position according to the floor marking, using a cabinet lifter or at least four people.

2.2.2 CABINET LAYOUT

Make sure all preparations for placement of cabinets at the site, including floor marking, were done during the site planning stage, see the environmental spec for MX-ONE SITE PLANNING.

For examples of cabinet layouts at the MX-ONE site, see the environmental spec for *MX-ONE SITE PLANNING*.

2.2.3 MOUNTING SETS

This sections lists all the mounting sets used when mounting and grounding the BYB 501 cabinets. Refer to the relevant mounting set table in each installation step.

In the tables screws are named for example M 4X8, M 4 = metric thread 4 millimeters, and 8 = 8 millimeters in length.

Table 2 Cabinet Frame (normally mounted)

1/BYB 501 180 Cabinet Frame			
Pos.	Title/Function	Product Number	Quantity
	RACK FRAME, H=1800, METRIC, W=450	SXK 118 0444/1	1
	MOUNTING BAR, H=1800, METRIC	SXA 210 026/1	2
	SCREW M 4X8	24/SBF 228 040/0080	24
A, B	FOOT WITH ADJUSTING NUTS	SXK 118 0159/1	4
	DESIGNATION LABEL	SVH 290 51/2	2
	EARTHING PLATE	SXA 123 0760/1	4
	SCREW M 4X8	24/SBF 228 040/0080	8
	PUSH-BUTTON	SKY 117 01/4	2
	SCREW 3.5X9.5	SBF 131 279/24	2
	ESD WRISTSTRAP	LYB 250 01/141	1
	LABEL	SVB 129 16	1
	MARKING LABEL	2/SVF 191 040/2	1
	MARKING PLATE2	SVF 191 131/1	1

2.2.4

POSITIONING THE CABINET

1. Make sure that holes for tip protection or earthquake bracing frame have been drilled.
 If not use the rack and the tip protection or the earthquake bracing frame as a template.
2. Position the cabinet in line with other cabinets and the site walls, see the environmental spec for *MX-ONE SITE PLANNING*.

2.2.5

LEVELING THE CABINET

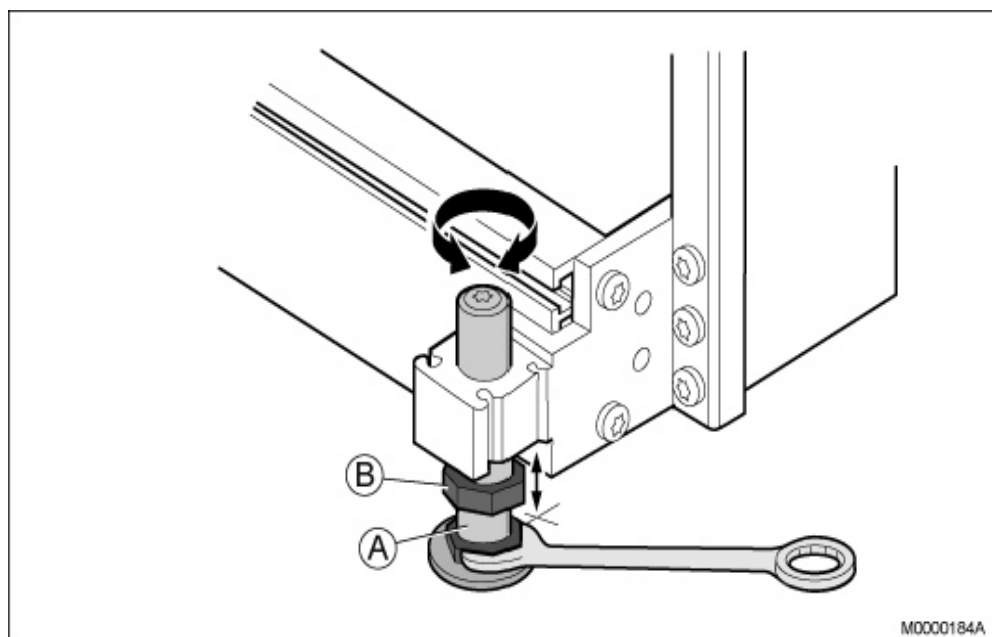

Figure 3: Leveling the Cabinet

1. Level the cabinet by adjusting the feet (A) using the 24-mm U-ring wrench, see Figure 3:Leveling the Cabinet on page 10
2. Verify that the cabinet is leveled horizontally and vertically, using a water level.
3. Tighten the locking nuts (B) on all feet using the 24-mm U-ring wrench, see Figure 3:Leveling the Cabinet on page 10
4. Proceed to the next installation stage:
 - For installation of a cabinet with tip protection, see 2.2.6 Installing the Cabinet with Tip Protection on page 9 .
 - For installation of a cabinet with earthquake bracing frames, see 2.2.7 Installing the Cabinet with Earthquake Bracing on page 13 .

2.2.6

INSTALLING THE CABINET WITH TIP PROTECTION

Table 3 Mounting Set for Tip Protection

18/BYB 501/4 Tip protection, generic			
Po s.	Title/Function	Product Number	Quantity
A	YOKE	SXA 123 0786/1	2
B	SPACER	SXA 123 0788/1	6
C	EXPANDER SCREW M 8X90	NSV 905 0805	4
D	INSULATING WASHER	SRB 186 080	4
E	SUPPORT	SXA 123 0785/1	4
F	CLAMP2	SXA 123 0787/1	4
G	NUT M 8	SBM 146 080/03	4

18/BYB 501/4 Tip protection, generic			
Pos.	Title/Function	Product Number	Quantity
H	INSULATING PLATE	SXA 123 0789/1	4
	STUD SCREW M 8X650	SBK 255 70	4
	EXPANDER NUT M 8x30	SXA 113 2519	4
L	WASHER	SCA 101 080/03	8
	BUSHING	SRG 107 16/1	4
	WASHER	SCA 350 06	4

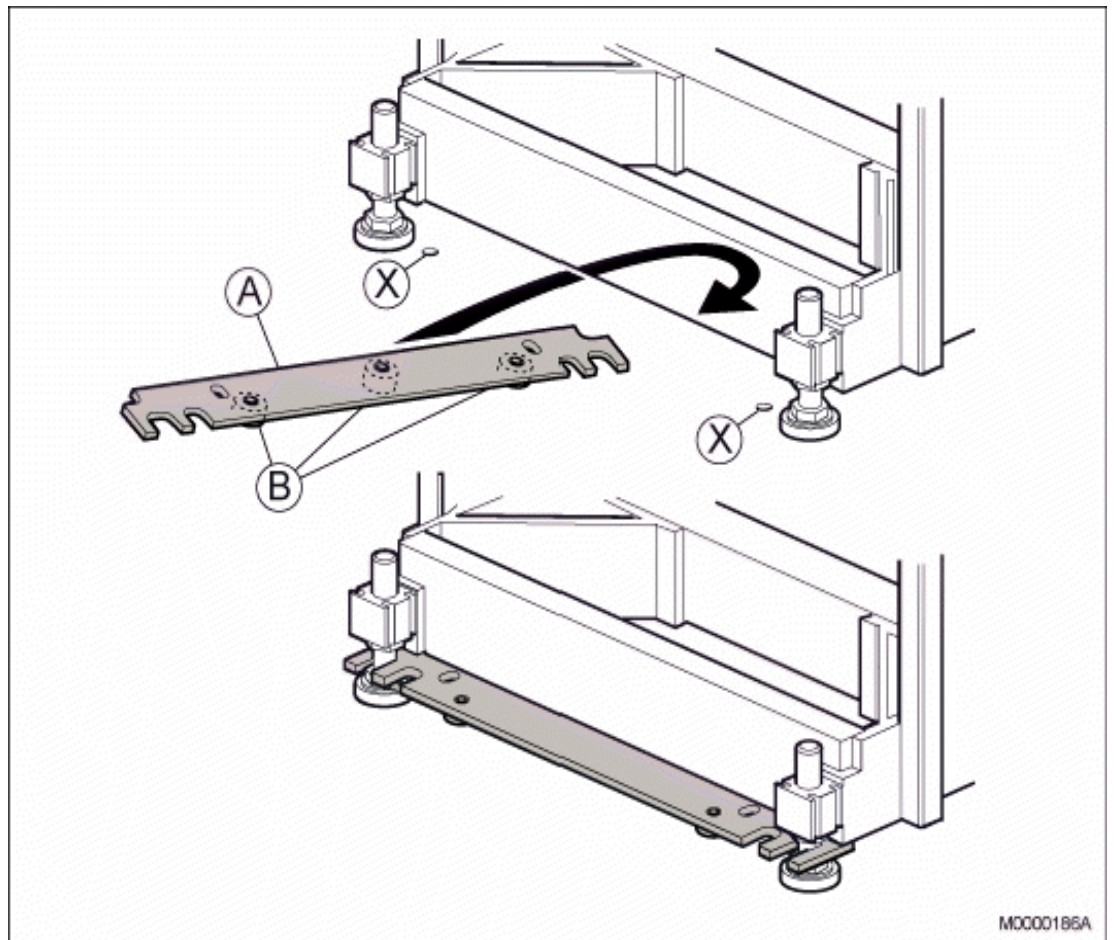

Figure 4: Installing the Tip Protection

Note: The following procedure must be performed for the feet at the front and for the feet at the back:

1. Insert three spacers (B) in the holes in the yoke (A), see Figure 3 Installing the Tip Protection on page 10
2. Slide the yoke under the cabinet between the feet.
3. Move the yoke back over the feet.
4. Align the holes in the yoke with the two anchoring holes (X) in the floor.

5. Anchor the cabinet to the floor according to the type of floor. For a concrete floor, see 2.2.6.1 Installing the Tip Protection on a Concrete Floor on page 11 . For a raised floor, see 2.2.6.2 Installing the Tip Protection on a Raised Floor on page 12 .

2.2.6.1

Installing the Tip Protection on a Concrete Floor

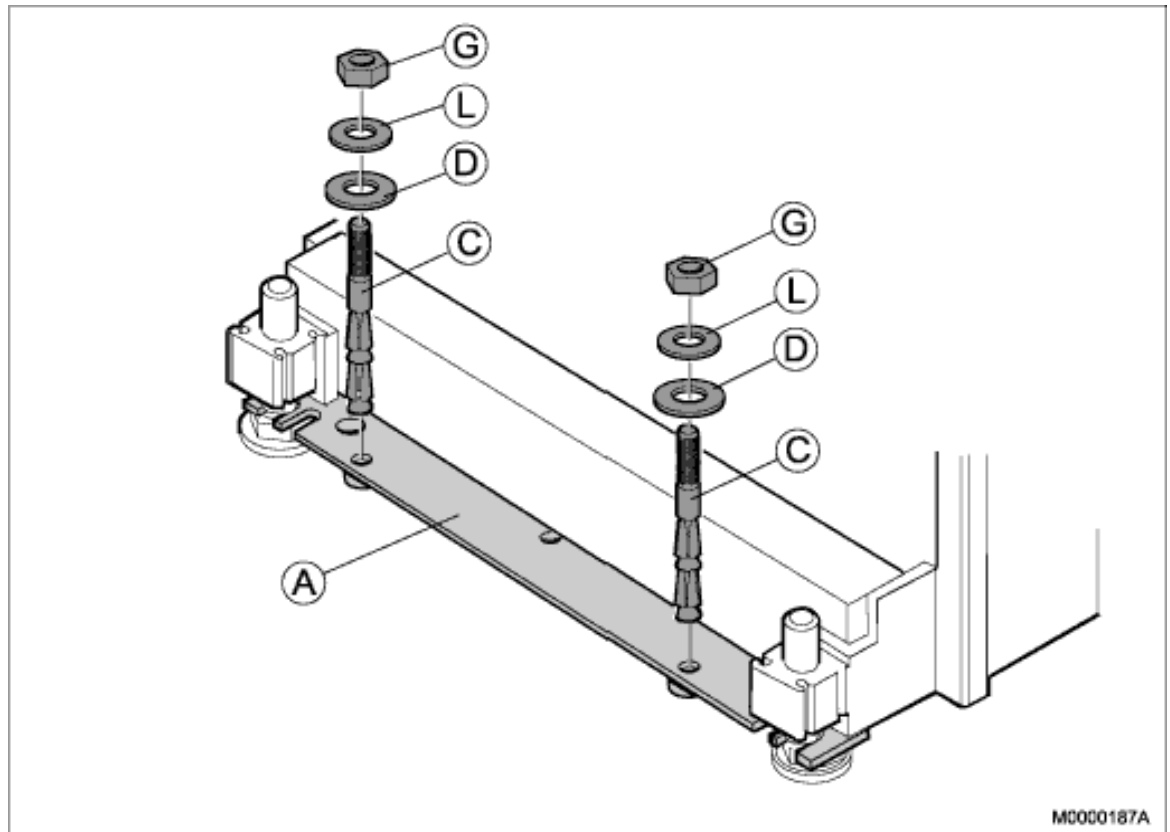

Figure 5: Installing the Expander Screw

Note: The following procedure must be performed for the feet at the front and for the feet at the back:

1. Insert two expander screws (C) through the yoke (A) and into the concrete, see Figure 4 Installing the Expander Screw on page 11
2. Hammer the two expander screws into position. Be careful to the threads.
3. Install two insulating washers (D), two washers (L), and two nuts (G) on the two expander screws, see Figure 4 Installing the Expander Screw on page 11
4. Tighten the two expander screws.
5. Proceed to the next installation stage, see 2.2.8 Fastening the Cabinets on page 16.

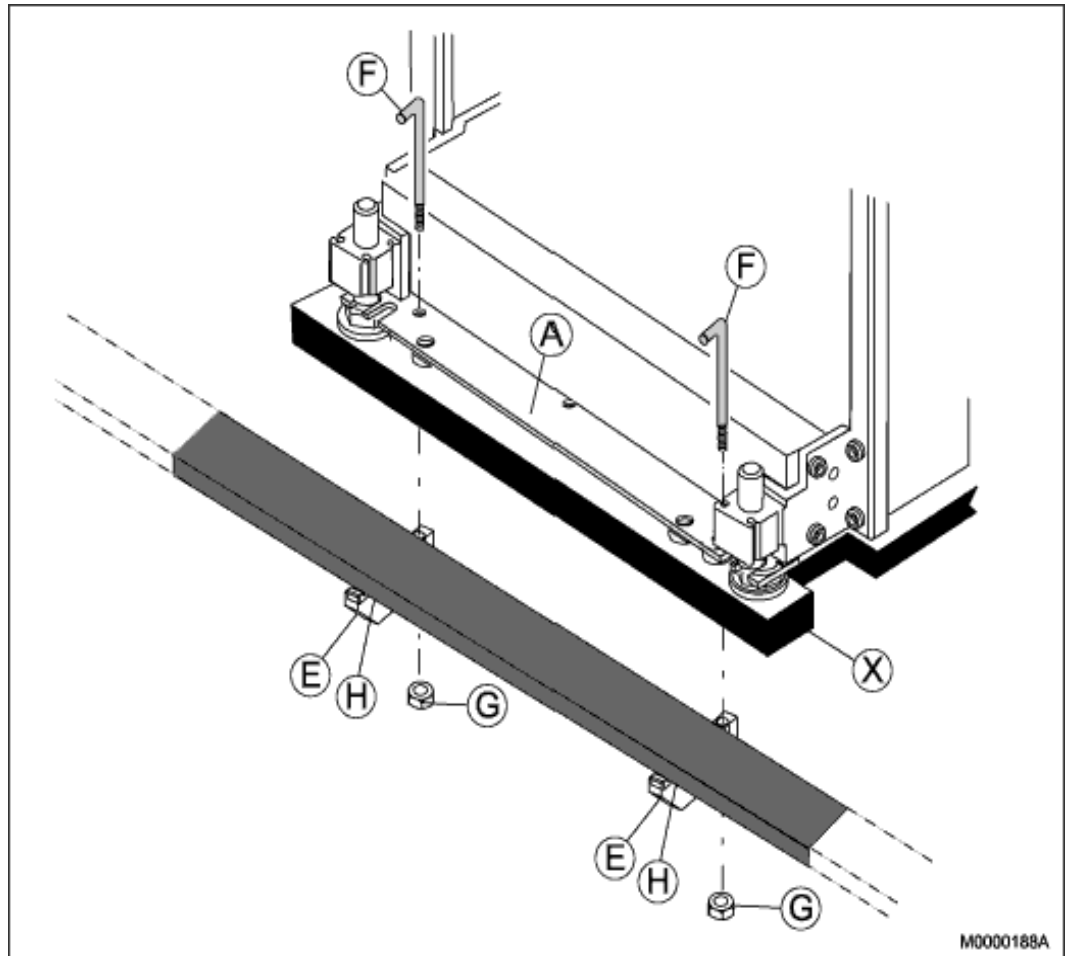

Figure 6: Installing the Tip Protection on a Raised Floor

Note: The following procedure must be performed for the feet at the front and for the feet at the back:

1. Insert two clamps (F) through the yoke (A) and the floor (X), see Figure 6:Installing the Tip Protection on a Raised Floor on page 13
2. Secure two supports (E) with two insulated plates (H) to the secondary section of the raised floor by using the two clamps (F) and two nuts (G).
3. Tighten the two nuts (G) from the underside.
4. Proceed to the next installation stage, see 2.2.8 Fastening the Cabinets on page 16.

2.2.7

INSTALLING THE CABINET WITH EARTHQUAKE BRACING

Table 4 Earthquake Set, Concrete Floor

17/BYB 501/1 (2 x SXK 118 0168/1) Earthquake Set, Concrete Floor			
Pos .	Title/Function	Product Number	Quantity
A	FIXING IRON	SXA 123 0380/1	4
B	BAR	SXA 123 0381/1	2
C	COASTER	SXA 123 0382/1	4
D	EXPANDER SCREW M 12/25	NSV 907 02	4
E	INSULATING BUSHING	SXA 106 0093/2	4
F	WASHER	SCA 118 210/78	4
G	WASHER	SCA 118 170/78	4
H	SCREW M 16X25	03/SBA 186 160/0250	4

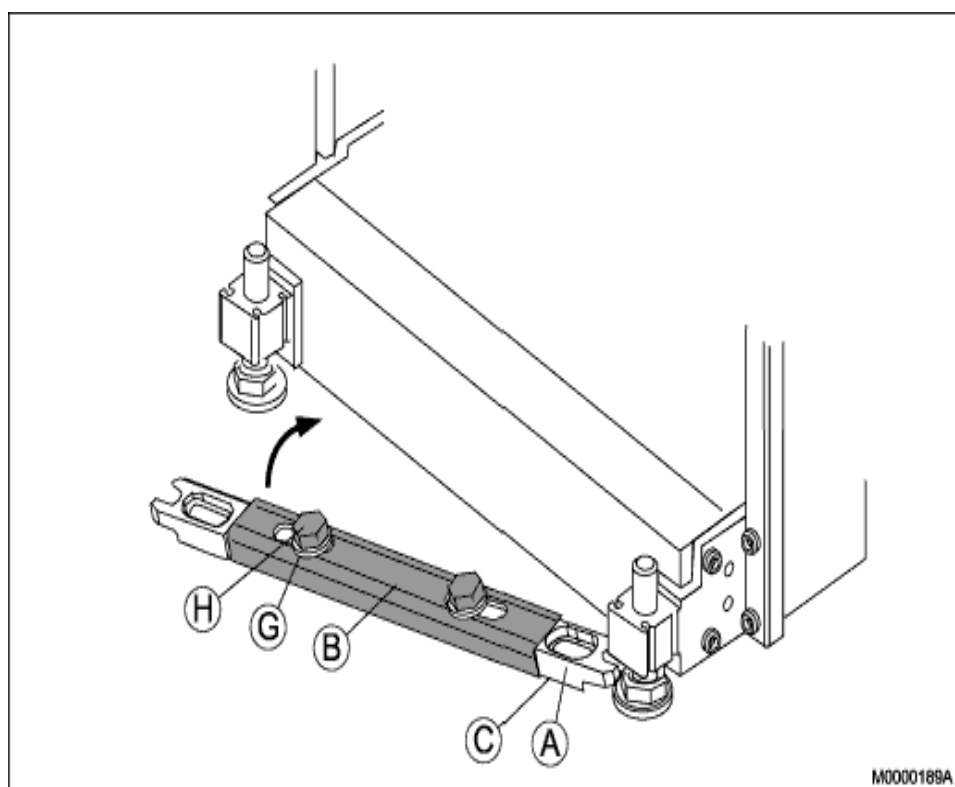
**Figure 7: Installing the Earthquake Bracing**

Note: The following procedure must be performed for the feet at the front and for the feet at the back:

1. Slide the earthquake bracing under the cabinet between the feet, see Figure 7: Installing the Earthquake Bracing on page 14
2. Verify that two coasters (C) are installed under the two fixing irons (A).
3. Install the two fixing irons (A) between the feet of the cabinet with the bar (B), two screws (H), and two washers (G).

4. Align the holes in the fixing irons over the anchoring holes in the floor.
5. Tighten the two screws (H) to a torque of 80 Nm.

2.2.7.1

Anchoring the Cabinet on a Concrete Floor

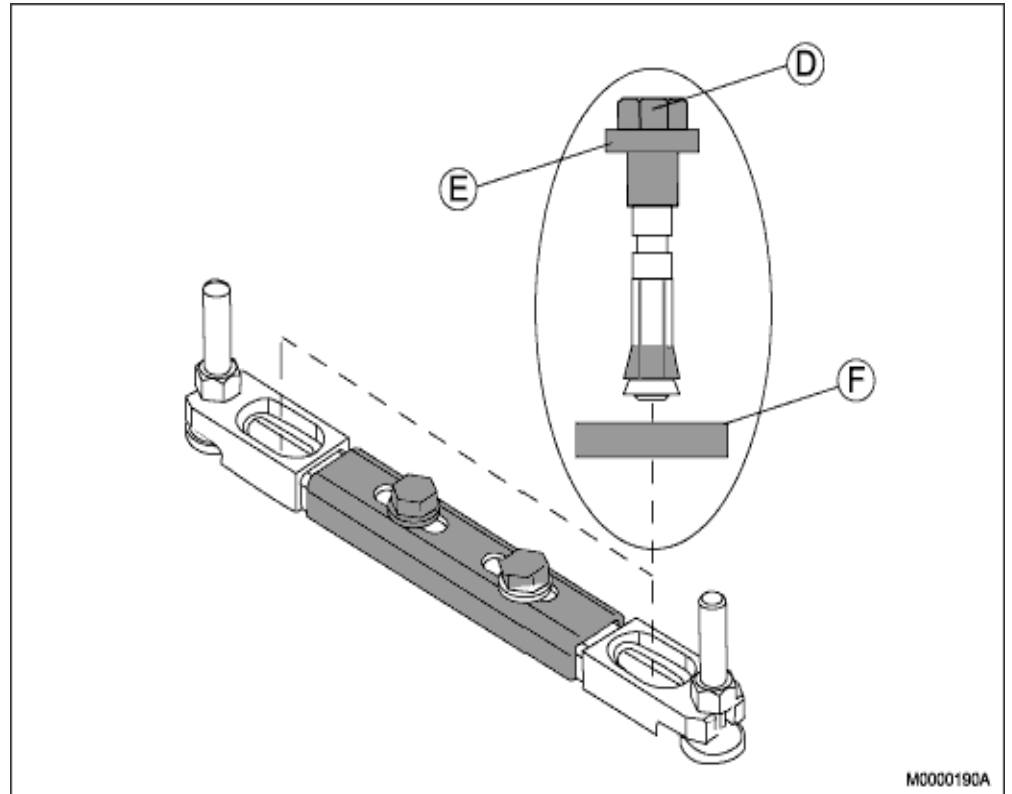

Figure 8: Installing the Expander Screw

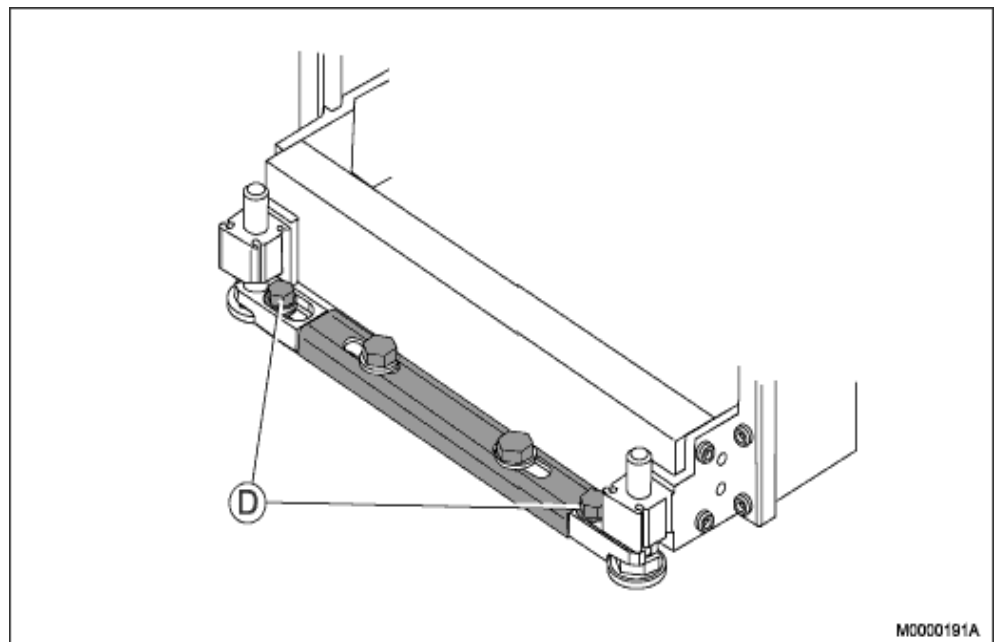

Figure 9: Securing the Earthquake Bracing

Note: The following procedure must be performed for the feet at the front and for the feet at the back:

1. Place two expander screws (D) with insulation bushing (E) and washer (F) through the fixing irons and into the concrete floor, see Figure 8:Installing the Expander Screw on page 15
2. Hammer the two expander screws into position.
3. Secure the two expander screws and earthquake bracing by tightening the screws until the red caps snaps off, see Figure 9:Securing the Earthquake Bracing on page 15

Note: The red cap snaps off when the screw has been tightened to the proper torque, exposing a green washer. The green washer should be intact, with no breaks. If the washer is found damaged during inspection, the screw must be verified to have a minimum torque of 64 Nm (but not exceeding 68 Nm).

4. Proceed to the next installation stage, see 2.2.8 Fastening the Cabinets on page 16 .

2.2.8

FASTENING THE CABINETS

Fasten the cabinets to each other either side-by-side or back-to-back.

2.2.8.1

Fastening Cabinets Back-to-Back

Table 5 Mounting Set, Back-to-Back

24/BYB 501/2 Mounting Set, Back-to-Back, d=800			
Pos.	Title/Function	Product Number	Quantity
B	SCREW	03/SBA 121 060/0160	12
A	GUIDE PIN2	SXA 123 0327/2	6

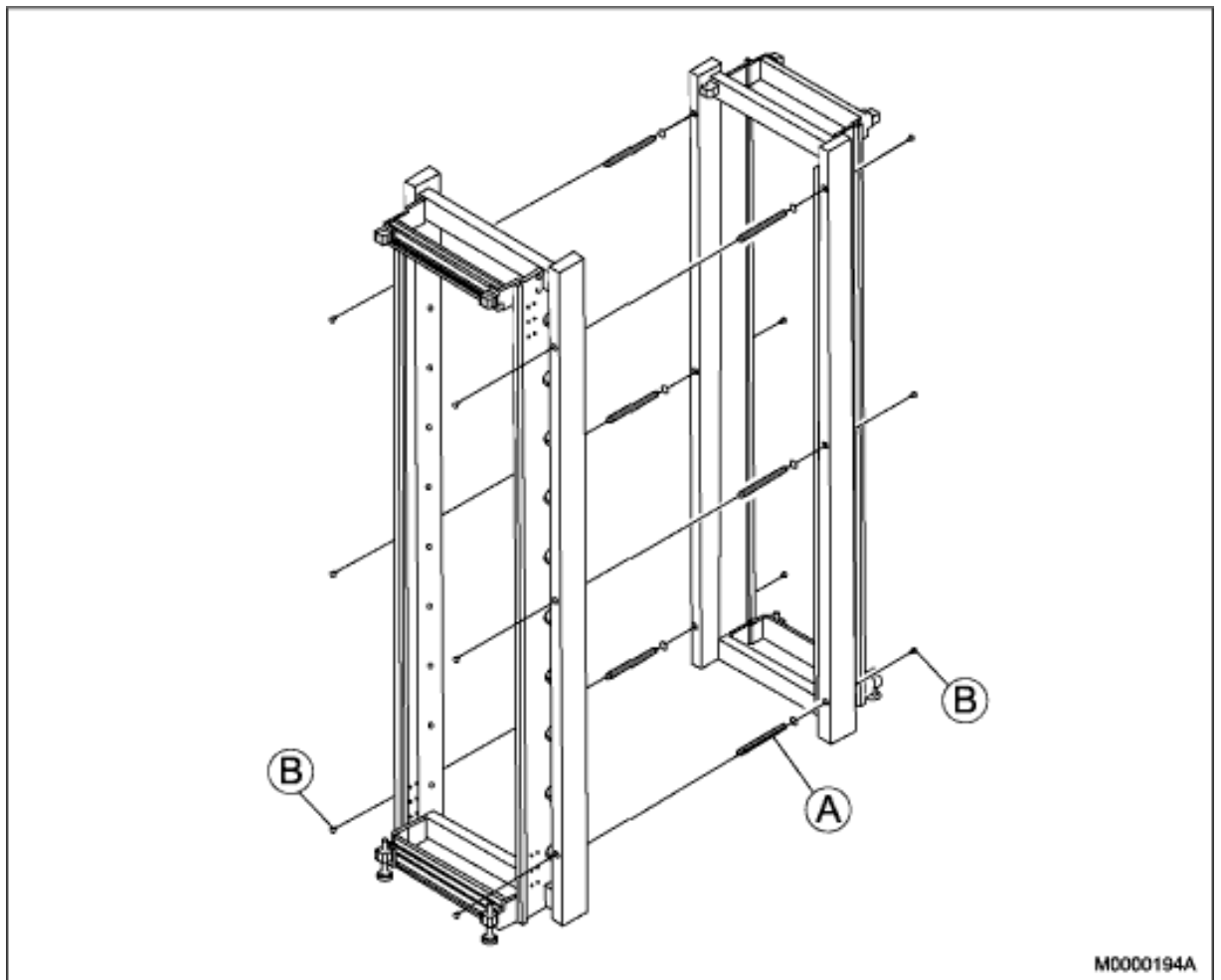

Figure 10: Fastening the Cabinets Back-to-Back

1. Position the two cabinets back-to-back, see Figure 10:Fastening the Cabinets Back-to-Back on page 17
2. Adjust the two cabinets to an equal level.
3. Fasten the two cabinets back-to-back with six guide pins (A) and twelve screws (B).
4. Verify that the torque of all mounting screws is set to 10+/-0.5 Nm.

2.2.8.2

Fastening Cabinets Side-by-Side

Table 6 Mounting Set, Side-by-Side

14/BYB 501, Mounting Set, Side-by-Side			
Pos.	Title/Function	Product Number	Quantity
A	PLATE	SXA 123 0368/1	3
B	SCREW M 6X10	24/SBF 228 060/0100	12

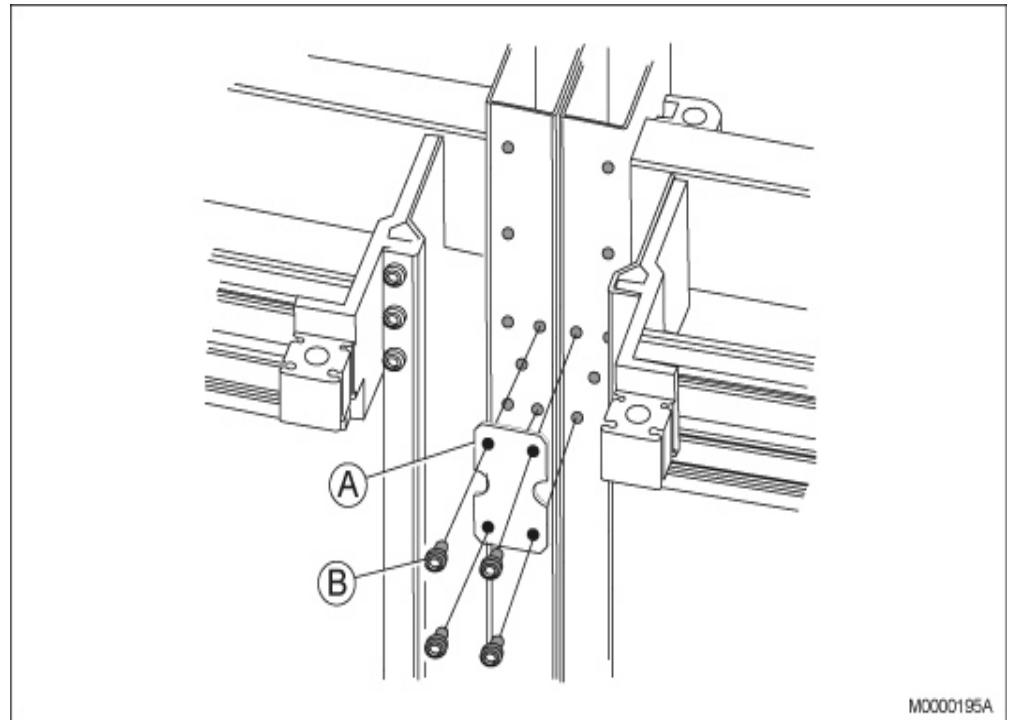

Figure 11: Fastening the Cabinets Side-by-Side

1. Position the two cabinets side-by-side, see Figure 11:Fastening the Cabinets Side-by-Side on page 18
2. Adjust the two cabinets to an equal level.
3. Fasten the two cabinets together side-by-side with three plates (A) and twelve screws (B) at the top, the middle, and the bottom of the two cabinets.
4. Verify that the torque of all mounting screws is set to 5 ± 0.5 Nm.

2.3

INSTALLING SUPPORTING CAPTIVE NUTS

Supporting captive nuts are used to secure hardware units to the metal rack inside the cabinet. Insert the captive nuts in the square cabinet holes, see Figure 12:Mounting the Captive Nuts in the Rack on page 19.

Note: Check that the mounting bars for the captive nuts are positioned at least 100 mm behind the door.

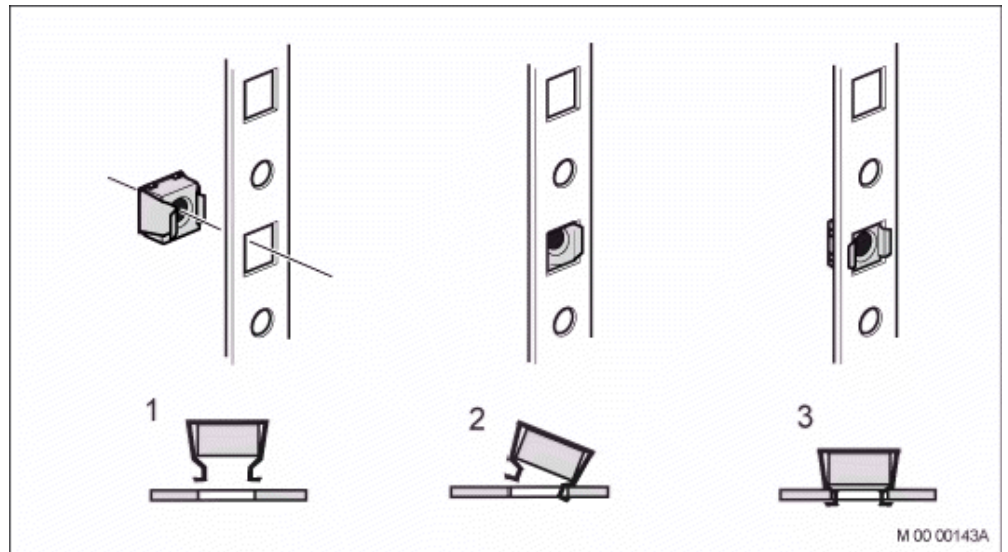

Figure 12: Mounting the Captive Nuts in the Rack

2.4 INSTALLING BATTERIES

This section describes the installation of 31-Ah (BKB 201 003/1) and 62-Ah (BKB 201 003/2) batteries. Make sure to leave room in the cabinet for the bigger batteries (62 Ah) even when installing smaller batteries.

Begin battery installation by installing the battery shelf, that is supplied with the mounting set for the power equipment, at the bottom of the cabinet, see Figure 13:Installing the Battery Shelf on page 20.

2.4.1 INSTALLING BATTERY SHELF

Use the following material set when installing the battery shelf:

Table 7 Material Set for Battery Shelf

NTM 144 266 Material set for battery shelf in 19-inch cabinet or frame			
Pos.	Title/Function	Product Number	Quantity
B	Battery shelf		1
L	Strapping belt		1
K	Set of 10-mm spacers for separating battery blocks		1
A	Captive nuts M6	SBM 173 060/03	4
C	Screws M6X16	78/SBA 121 060/0160	4

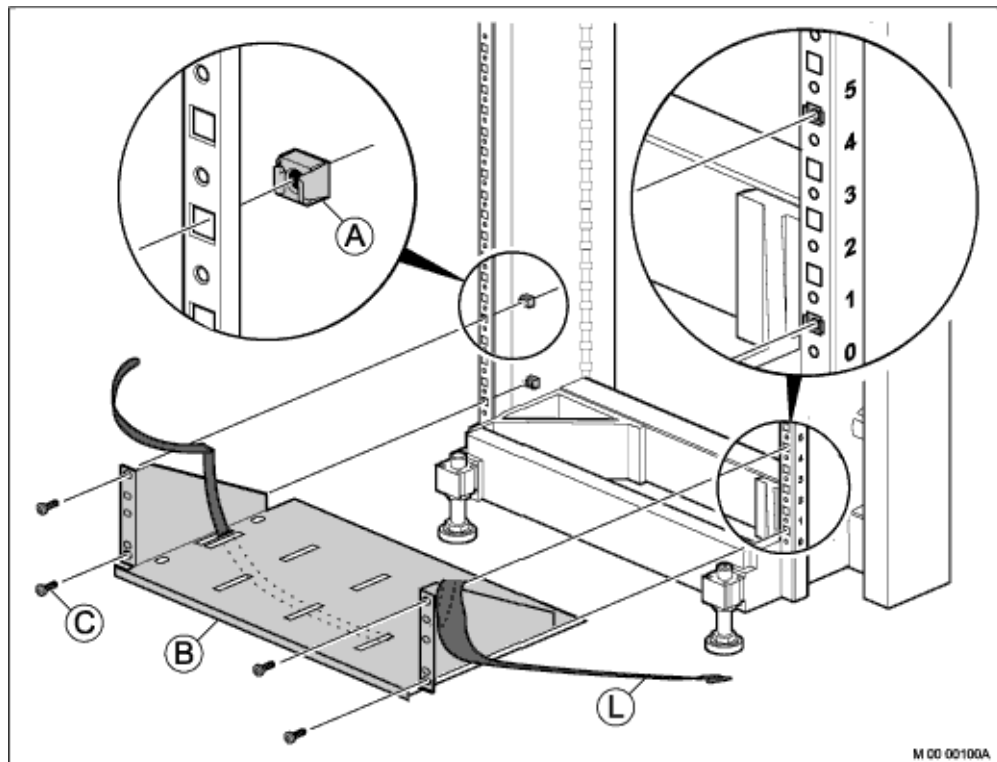

Figure 13: Installing the Battery Shelf

1. Mount four captive nuts (A) (2.3 Installing Supporting Captive Nuts on page 18) in the cabinet according to the number positions shown, see Figure 13:Installing the Battery Shelf on page 20.
2. Insert the strapping belt (L) through the battery shelf.
3. Fasten the battery shelf (B) using four screws (C).

2.4.2

INSTALLING THE BATTERY STRING

Use one of the following material sets when installing the batteries:

Table 8 Material Set for 48 V 31-Ah Battery

BKB 201 003/1 Material set for 48 V 31-Ah battery			
Pos.	Title/Function	Product Number	Quantity
A	Battery set	BKC 508 03/1	4
	Mounting set for battery	NTM 144 265	1

Table 9 Material Set for 48 V 62-Ah Battery

BKB 201 003/2 Material set for 48 V 62-Ah battery			
Pos.	Title/Function	Product Number	Quantity
A	Battery set	BKC 508 03/2	4
	Mounting set for battery	NTM 144 265	1

Table 10 Mounting Set for Battery

NTM 144 265 Mounting set for battery			
Pos.	Title/Function	Product Number	Quantity
B	SCREW M 8X25		2
C	SCREW M 8X16		8
D	TUBE SPACER 18 X16 metal		2
E	CONTACT WASHER for 6.3-mm flat lug terminals		3
F	PLAIN WASHER		8
G	SPRING WASHER		8
H	CONNECTOR BRIDGE		3
I	INSULATING COVER for plus and minus terminals		2
K	Set of spacers 10-mm for separating battery blocks		1
L	Grey double-insulated cable, 10 mm ² area, 2 m long, (plus pole). (not UK)		1
M	Black double-insulated cable, 10 mm ² area, 2 m long, (minus pole). (not UK)		1
	Battery service instruction sheet in a frame for wall mounting		1

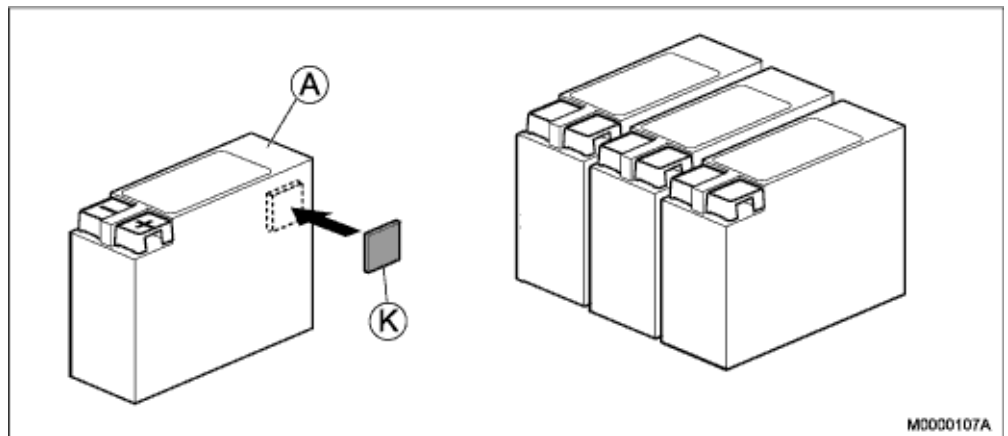

Figure 14: Battery Block Spacer

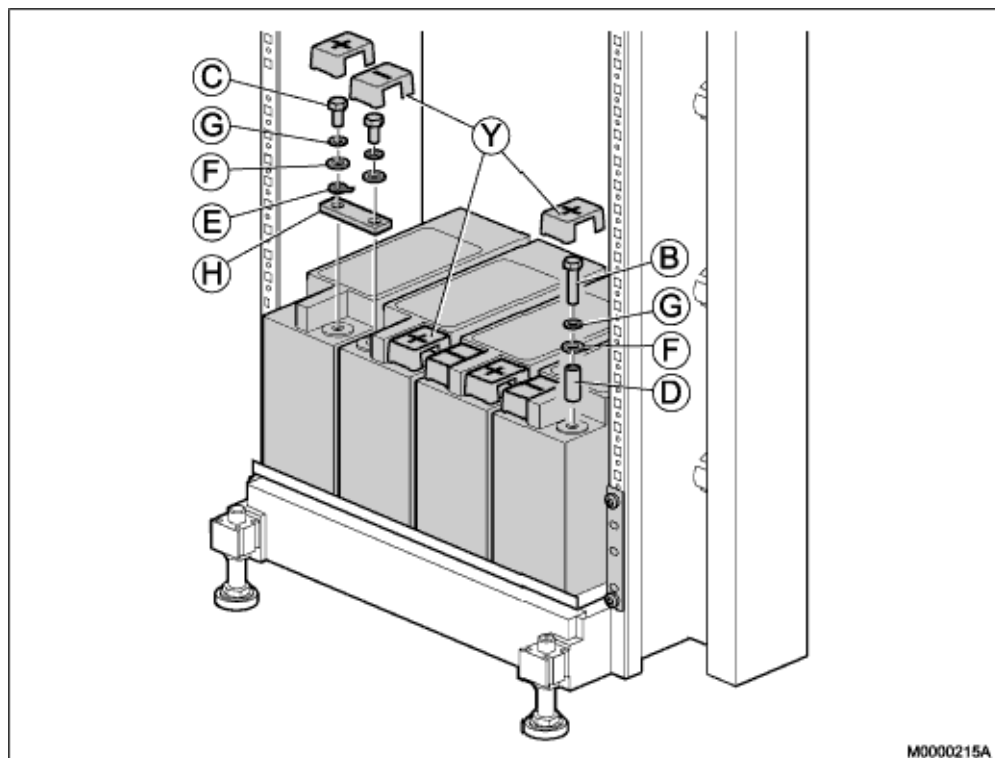

Figure 15: Installing the Batteries

Note: Before working on any equipment, be aware of the hazards involved with the electrical circuitry and be familiar with the standard practices for preventing accidents.

To mount the batteries in the battery shelf, perform the following steps:

1. Mount the spacers (K) between the battery blocks (A), see Figure 14: Battery Block Spacer on page 21.
2. Place the safety strap through the slots in the battery shelf, see Figure 16: Battery String Safety Strap on page 23.
3. Place the batteries on the shelf, see Figure 15: Installing the Batteries on page 22. Make sure the front side of the batteries with the contact poles and the labels is facing the cabinet front.
4. Pull the batteries towards the shelf front edge.
5. Connect the batteries to each other by applying the connector bridge (H), plain washer (F), spring washer (G), by using the pole screws (C) from the batteries.
6. For measuring 12, 24, and 36 V DC insert three contact washers with flat lug terminals (E) on top of each connector bridge.
7. Tighten the six screws.
8. Apply the metal tube spacer (D), plain washer (F), spring washer (G), and 25-mm screw (B) on the plus pole of the rightmost battery block (do not tighten).
9. Apply the metal tube spacer (D), plain washer (F), spring washer (G), and 25-mm screw (B) on the minus pole of the leftmost battery block (do not tighten).
10. Position insulating pole covers (Y) on each of the four batteries, and press them down.

11. Place the strapping belt (L) around the batteries and tighten the strap, see Figure 16:Battery String Safety Strap on page 23.
12. Fasten three warning labels, parallel connection of batteries (SVB 131 70), one on the right-hand side battery, and two at the bottom of the cabinet, see Figure 17:Parallel Connection of Batteries Warning Label on page 23 and see Figure 35:Warning Label SVB 131 70 on page 41.

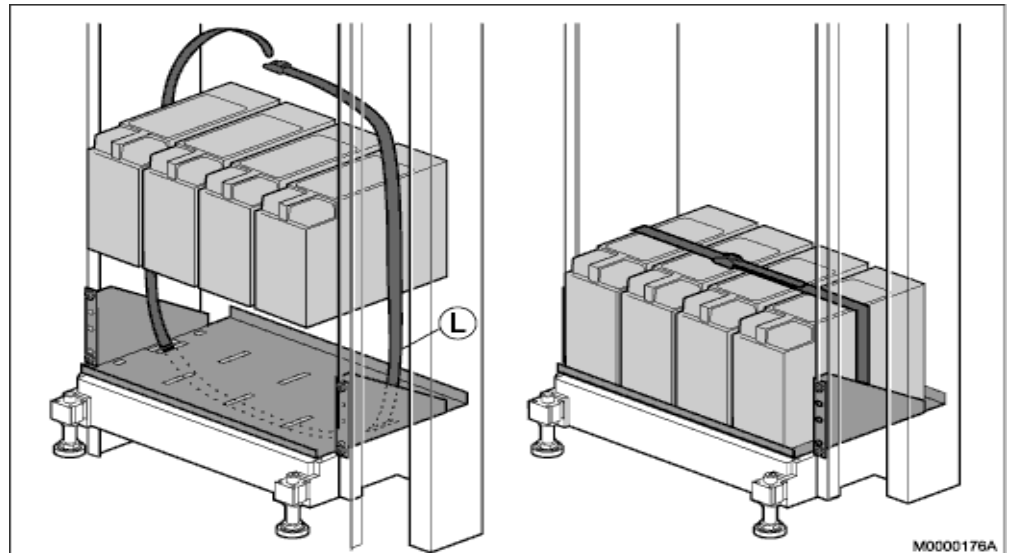

Figure 16: Battery String Safety Strap

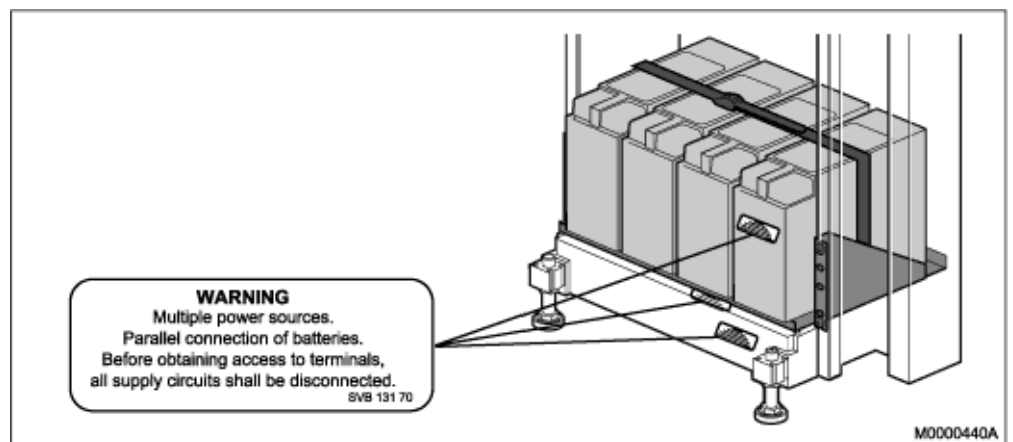

Figure 17: Parallel Connection of Batteries Warning Label

2.5

INSTALLING AC/DC UNIT

This section describes the installation of the AC/DC power unit in the cabinet.

Before working on any equipment, be aware of the hazards involved with the electrical circuits and be familiar with the standard practices for preventing accidents.

The Power inlets to the AC/DC is on the rear side. Check that the power connection are accessible after mounting, else connect the Power cables before mounting. Also secure the Power cables with a cable tie, to avoid disconnection. see Figure 30:Secure Main cables on page 37

Note: It is a must to follow the suppliers Installation User guide/Manuals.

2.5.1

INSTALLING THE AC/DC UNIT

The installation below is intended for the AC/DC unit 51305282. For specific information of the 51305282, see supplier Instruction Manual doc No. PM110_6500_00, and Quick Install Guide doc No. 110_6500_00-QR.

If any other type of AC/DC unit are installed, the same step below shall be taken.

Note: The AC/DC unit can have a shelf mounted below. This will ease the electrical connection. The shelf to be used is 86/BYB501. See 2.10 Installing a Cabinet Shelf on page 38.

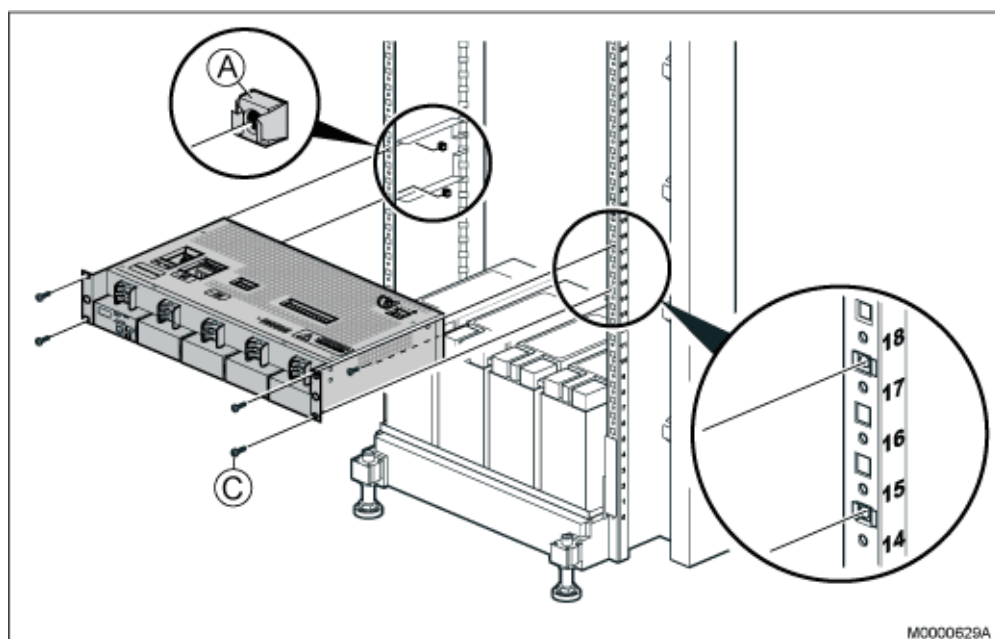

Figure 18: Installing AC/DC Unit

1. If not already done, mount captive nuts (A) (2.3 Installing Supporting Captive Nuts on page 18).
2. Place the AC/DC unit on the mounted shelves (86/BYB501).
3. Use the four screws (C) supplied with the mounting kit to fasten the AC/DC unit to the captive nuts in the cabinet. Do not tighten the screws, as they need to be opened again when connecting cables to the AC/DC unit.
4. Connect the mains supply, distribution/load cables and battery cable acc to manufacturers instruction/manual. **NOTE:** Do not Power up the Unit in this stage.
5. Fasten the warning label, energy hazard (SVB 131 75) as close as possible to the circuit breakers on the front of the AC/DC unit.

2.6

INSTALLING MX-ONE CLASSIC

This section describes the installation of the subracks containing the MX-ONE Classic boards in the cabinet. Note that this section does not describe the installation of separate boards in the subrack. The MX-ONE Classic consists of one subrack.

Note: This equipment have to be connected to protective ground. Connect a grounding cable to the bracket at the earthing point, close to the earthing symbol located at the right hand side of the chassis. See Figure 19:Earthing point 7U-chassis on page 25.



Figure 19: Earthing point 7U-chassis

This section also describes installation of two subracks, the upper called A and the lower called B. Both can of course be a Subrack A.

Use the following material sets when installing the MX-ONE Classic and Fan Unit:

Note: If only one subrack is to be installed mount the lower air plate on this subrack. To fulfill the demands on Fire Enclosure for the 7U chassis, the Air plate SXA1122330/1 included in NTM144262 have to be mounted.

For instructions see 2.6.1Mounting the Lower Air Plate on page 27.

Table 11 Mounting Set for Subrack A

NTM 144 262 Mounting set for subrack A			
Pos.	Title/Function	Product Number	Quantity
D	AIR PLATE, upper	SXA 112 2329/1	1
E	AIR PLATE, lower	SXA 112 2330/1	1
C	SCREW M 6X16	78/SBA 121 060/0160	8
A	CAPTIVE NUT M6	SBM 173 060/03	8
F	SCREW M 4X6	24/SBF 228 040/0060	2
G	CABLE LUG	SNG 804 23	1
K	LABEL FOR ESD	SVB 129 05/2	1

Table 12 Mounting Set for Subrack B

NTM 144 263 Mounting set for subrack B			
Pos.	Title/Function	Product Number	Quantity
H	Air plate, front	SXA 112 2331/1	1
I	Air plate, rear	SXA 112 2332/1	1
C	SCREW M 6X16	78/SBA 121 060/0160	4
A	CAPTIVE NUT M6	SBM 173 060/03	4
F	SCREW M 4X6	24/SBF 228 040/0060	2

NTM 144 263 Mounting set for subrack B			
Pos.	Title/Function	Product Number	Quantity
G	CABLE LUG (only used if the two subracks are mounted in separate cabinets)	SNG 804 23	1
K	LABEL FOR ESD (only used if the two subracks are mounted in separate cabinets)	SVB 129 05/2	1

2.6.1

MOUNTING THE LOWER AIR PLATE

Before installing subrack B, install the lower air plate in the subrack. Perform the following steps:

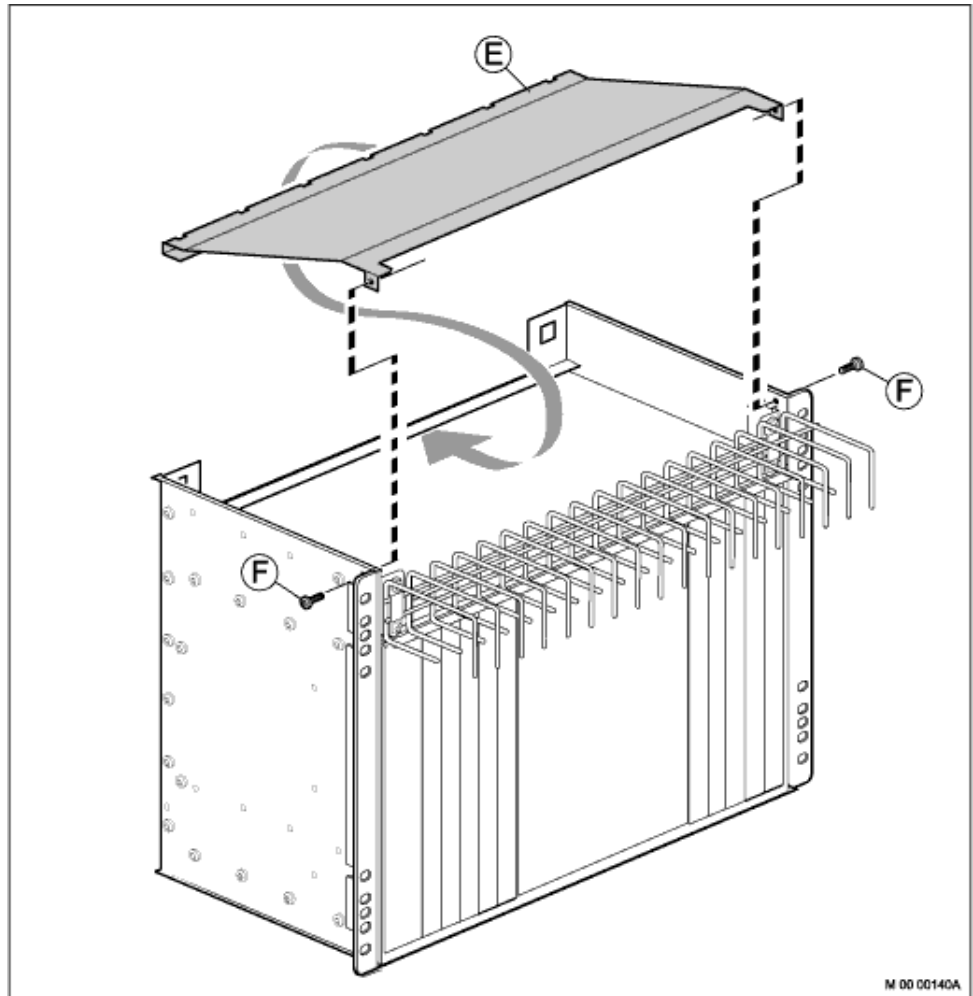

Figure 20: Mounting the Lower Air Plate

1. Place subrack B in an upside-down position on a steady surface.
2. Insert the edge of the lower air plate (E) in the slot at the rear side of the subrack.
3. Lower the air plate to level it with the screw holes in the subrack, as demonstrated by the dotted line.
4. Fasten the air plate to the subrack from both sides using two screws (F).

Parts from this mounting set are used when installing the fan unit, leave the remaining parts at hand.

2.6.2

INSTALLING SUBRACK B (OR SECOND SUBRACK A)

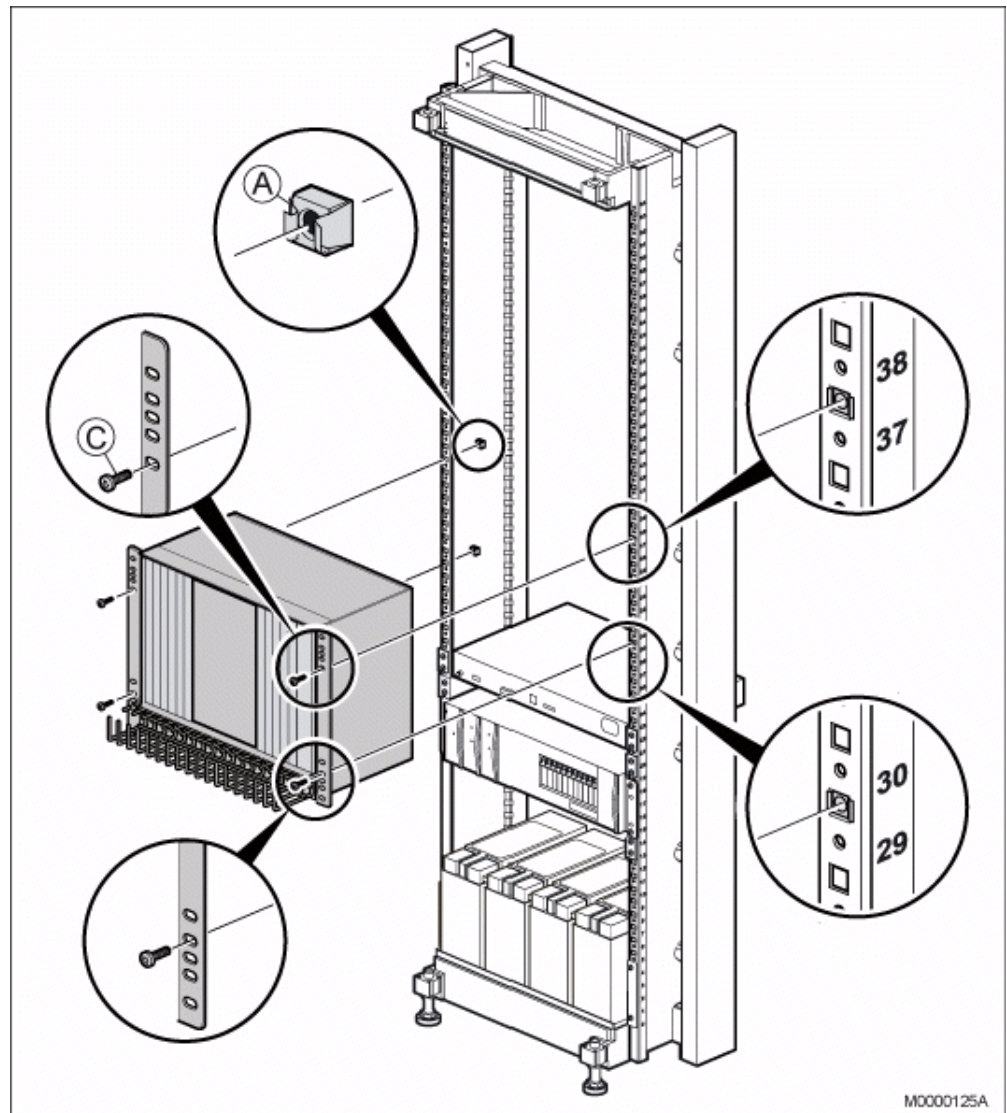

Figure 21: Installing Subrack B

The lower air plate is only mounted in subrack B (lower subrack if two subracks are mounted onto of each others), see 2.6.1 Mounting the Lower Air Plate on page 27. In subrack A (upper subrack), front and rear air plates are installed instead.

- 1) Mount four captive nuts (A) (2.3 Installing Supporting Captive Nuts on page 18) according to the number positions shown.
- 2) Use the screws (C) to fasten the subrack to the captive nuts in the cabinet. It is very important to use the correct holes in the subrack brackets. For the correct holes.

Parts from this mounting set are used at a later installation stage, leave the remaining parts at hand.

2.6.3

MOUNTING THE FRONT AIR PLATE IN SUBRACK A

To prepare subrack A for installation in the cabinet, first mount front and rear air plates in the subrack as follows:

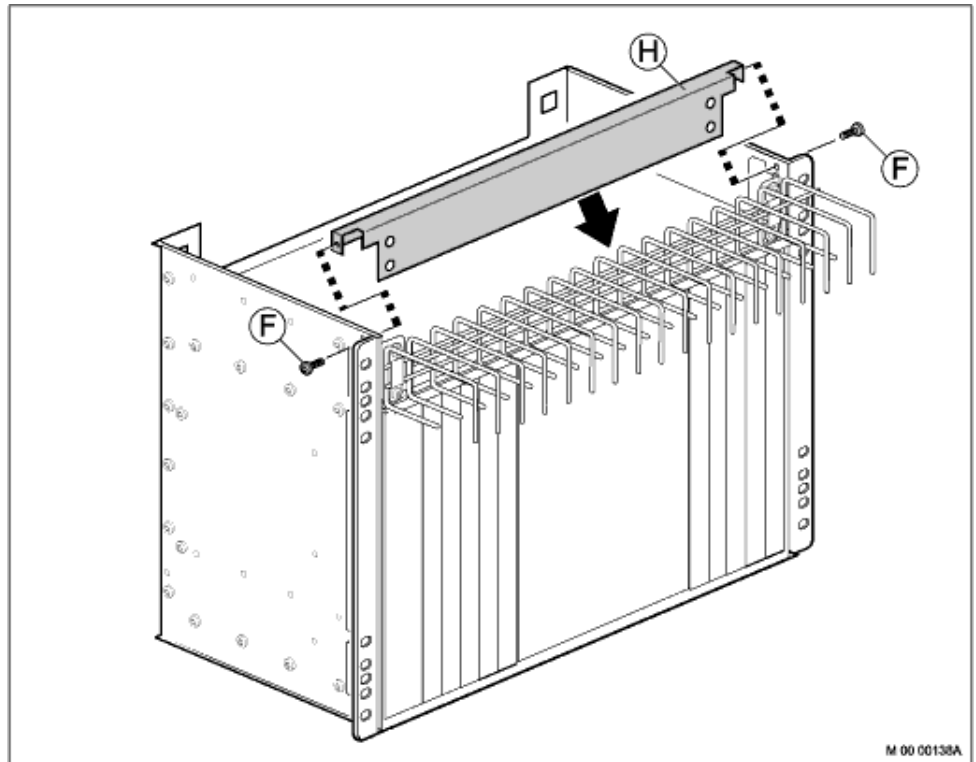

Figure 22: Mounting the Front Air Plate in Subrack A

1. Place subrack A in an upside-down position on a steady work surface.
2. Insert the front air plate (H) to the slot against the cable chute.
3. Fasten the front air plate to the subrack by using two screws (F).

Parts from this mounting set are used at a later installation stage, leave the remaining parts at hand.

2.6.4

MOUNTING REAR AIR PLATE IN SUBRACK A

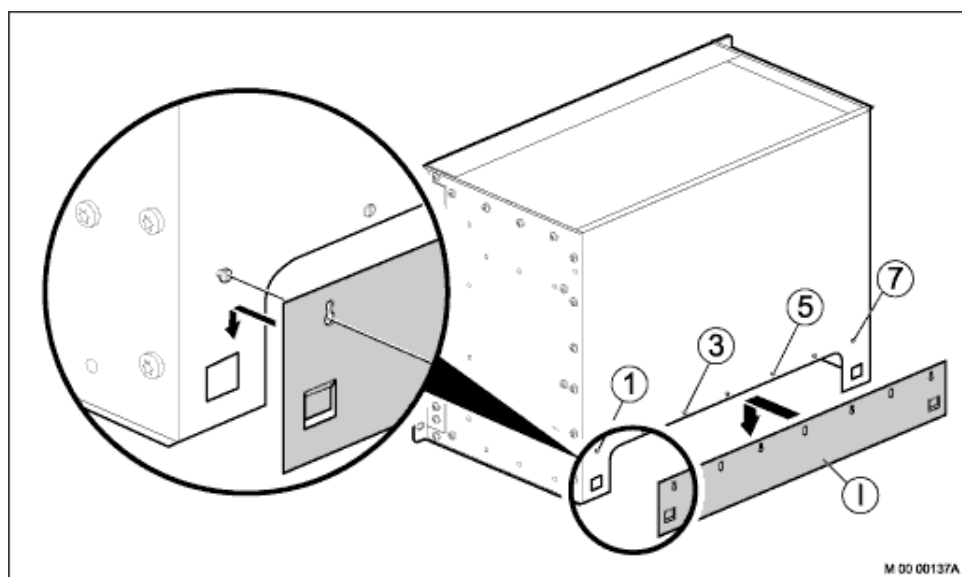

Figure 23: Mounting Rear Air Plate in Subrack A

1. Turn subrack A back to an upright position.
2. Loosen, but do not remove the screws (1, 3, 5, and 7) on the back panel of the subrack, so they stick out a few millimeters. Note that only these four screws should be loosened.
3. Position the four key holes of the rear air plate on the half-released subrack screws and slide down the air plate. Make sure that the squared plates hook into position.
4. Fasten the screws 1, 3, 5, and 7.

Parts from this mounting set are used at a later installation stage, leave the remaining parts at hand.

2.6.5

INSTALLING SUBRACK A

Note: Make sure that the front and rear air plates are mounted.

For more information see 2.6.3 Mounting the Front Air Plate in Subrack A on page 29 and 2.6.4 Mounting Rear Air Plate in Subrack A on page 30.

To install subrack A, perform the following steps:

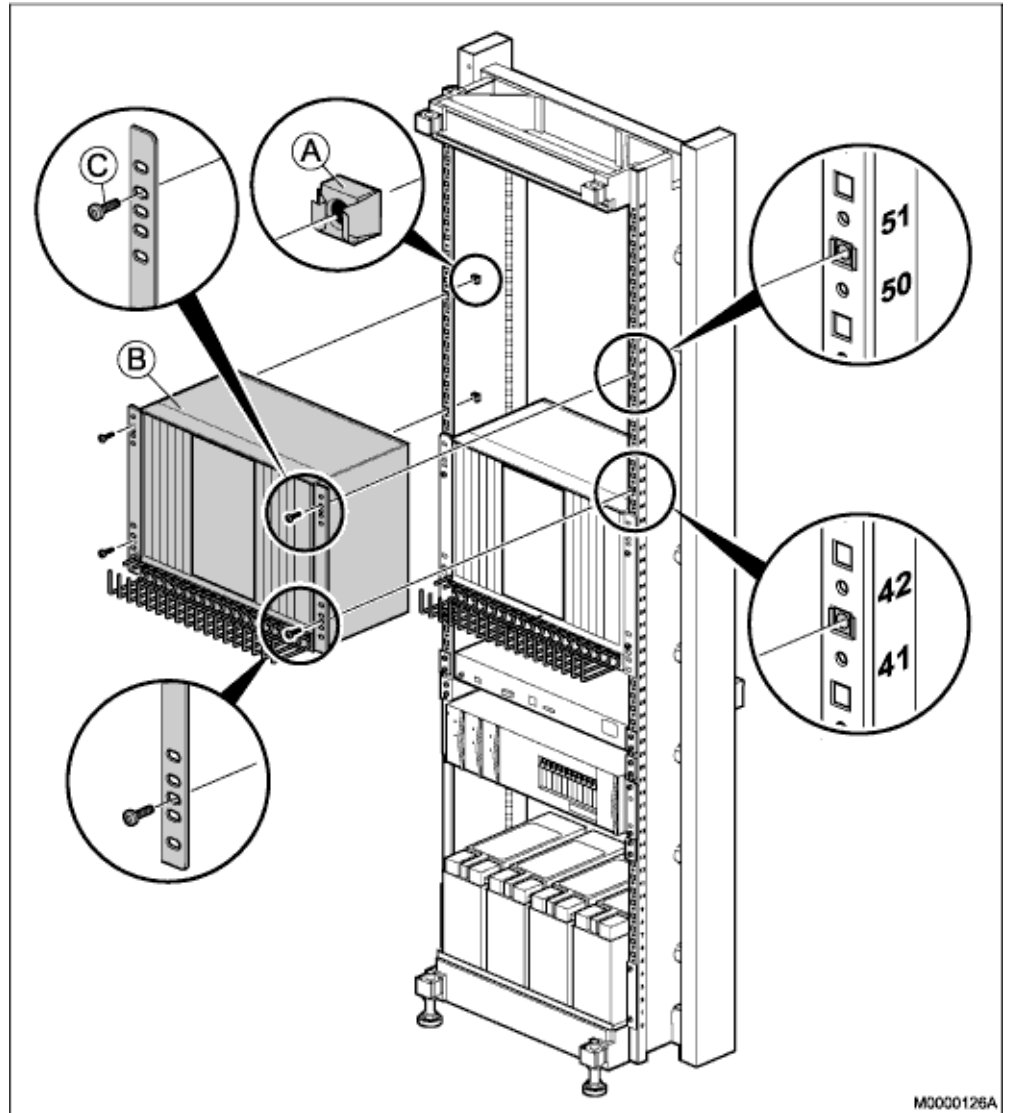

Figure 24: Installing Subrack A

- 1) Mount four captive nuts (A) (2.3 Installing Supporting Captive Nuts on page 18) according to the number positions shown.
- 2) Use the screws (C) to fasten the subrack A to the captive nuts in the cabinet. Make sure that no gap is left between subracks A, and B.

Parts from this mounting set are used at a later installation stage, leave the remaining parts at hand.

2.7

INSTALLING THE FAN UNIT

This section describes the installation of fan unit and upper air plate in the cabinet.

Table 13 Mounting Set for Fan Unit

52/BYB 501 Mounting Set included in Fan Unit BFD 509 08/4			
Pos.	Title/Function	Product Number	Quantity
D	SLIDE	SXA 123 0320/1	2
E	SPRING	SXA 123 0321/1	2
F	SCREW	24/SBF 228 040/0080	2
C	SCREW M 6X16	03/SBA 121 060/0160	4
A	CAPTIVE NUT M6	SBM 173 060/03	4

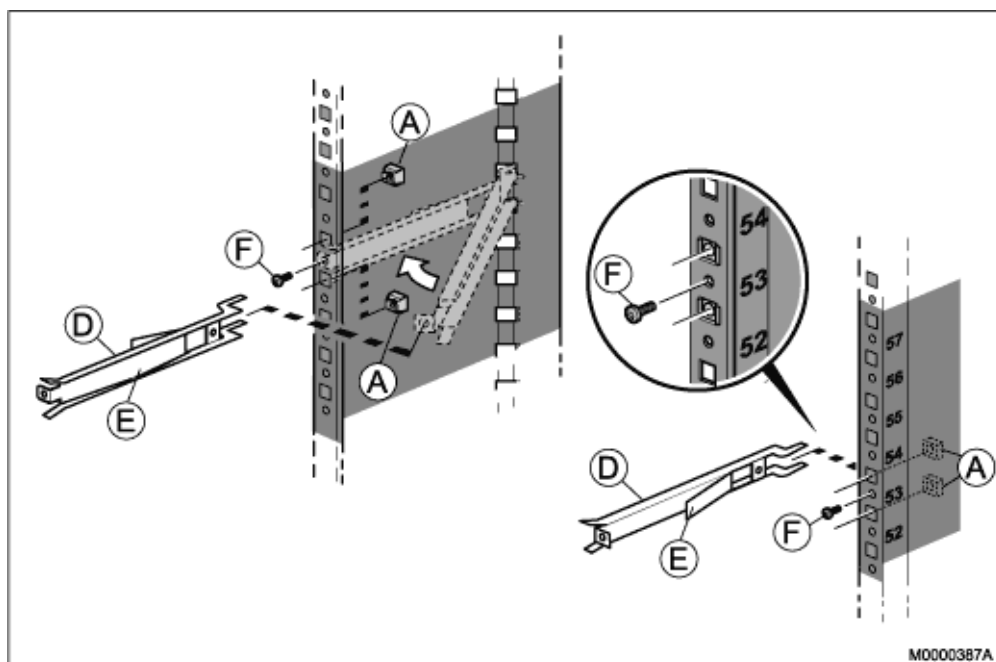
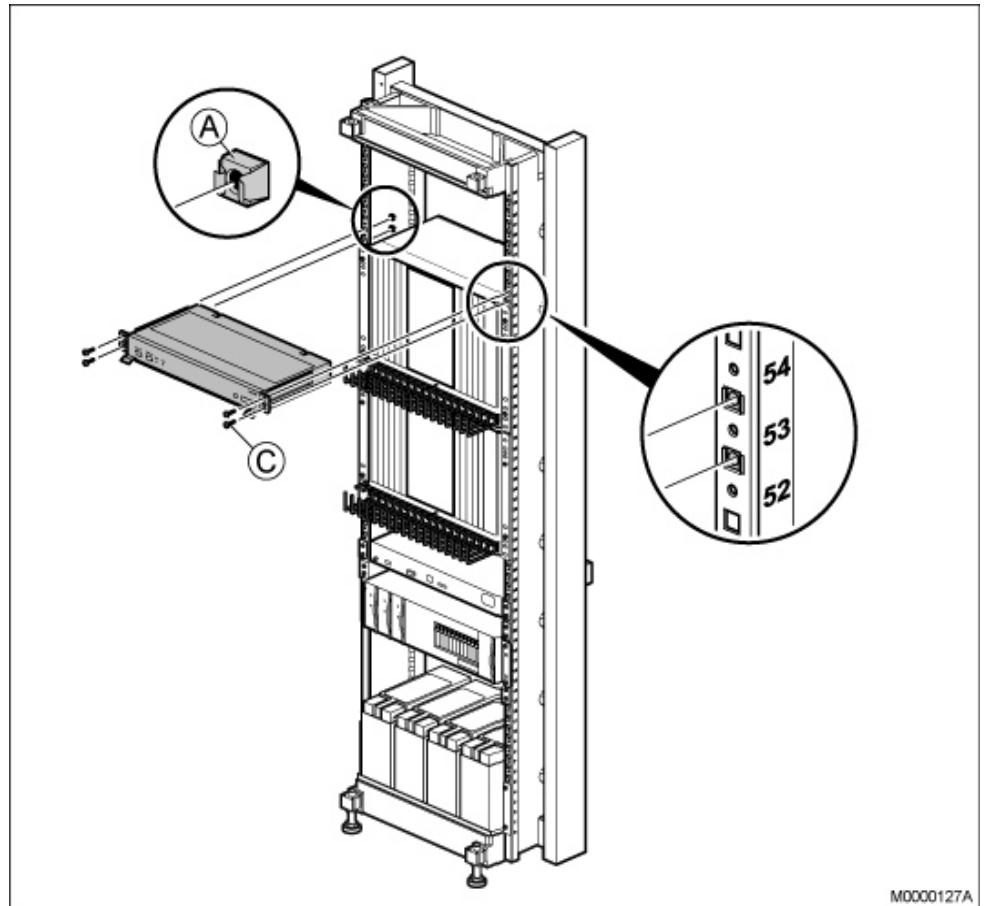

Figure 25: Installing Slides



M0000127A

Figure 26: Installing the Fan Unit

- Mount four captive nuts (A) (see 2.3 Installing Supporting Captive Nuts on page 18) according to the number positions shown, see on page 32 and see on page 33.
- Insert the two slides (D) with springs (E), see on page 32 and fasten them with the two screws (F).
- Slide the fan unit in position.
- Fasten the fan unit to the four captive nuts (A) in the cabinet. using the four screws (C).

Make sure that no gap is left between subrack A, and the fan unit.

2.7.1

INSTALLING UPPER AIR PLATE

Note: The upper air plate is only mandatory if hardware will be installed above the fan unit.

To install the upper air plate, perform the following steps:

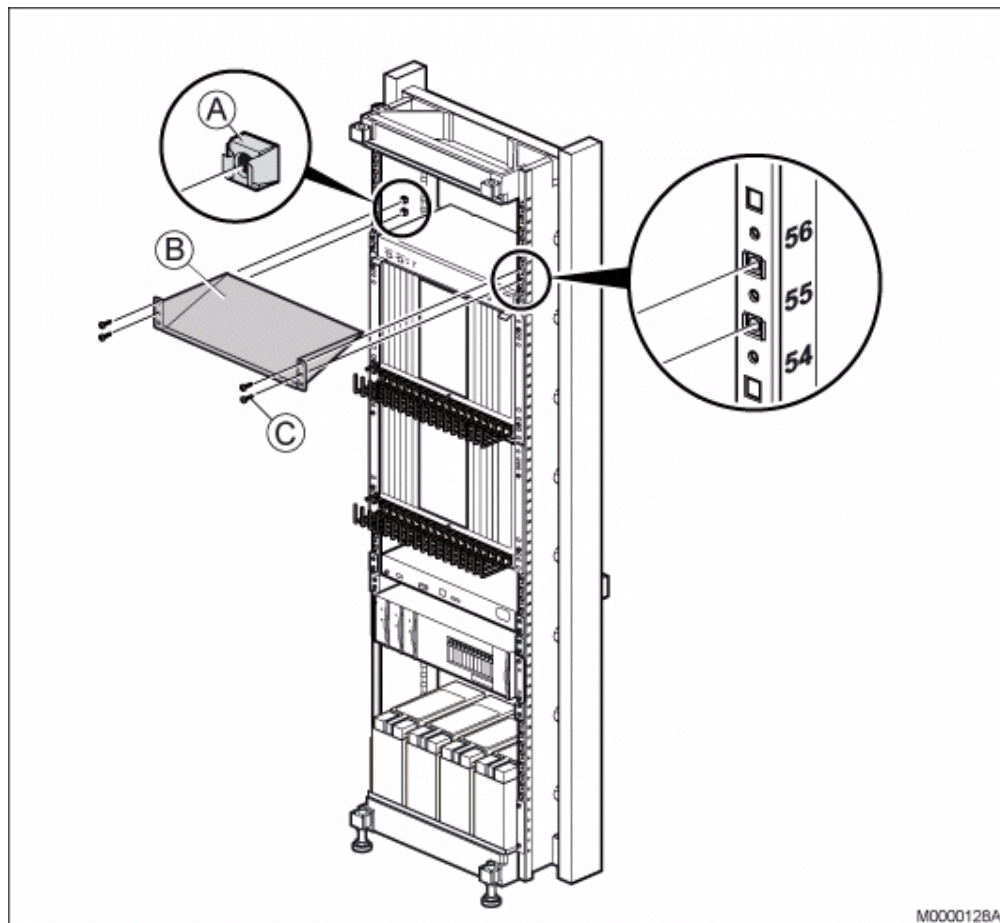

Figure 27: Installing Upper Air Plate

1. Mount four captive nuts (A) (see 2.3 Installing Supporting Captive Nuts on page 18) according to the number positions shown.
2. Fasten the air plate (B) to the four captive nuts in the cabinet using the four screws (C).

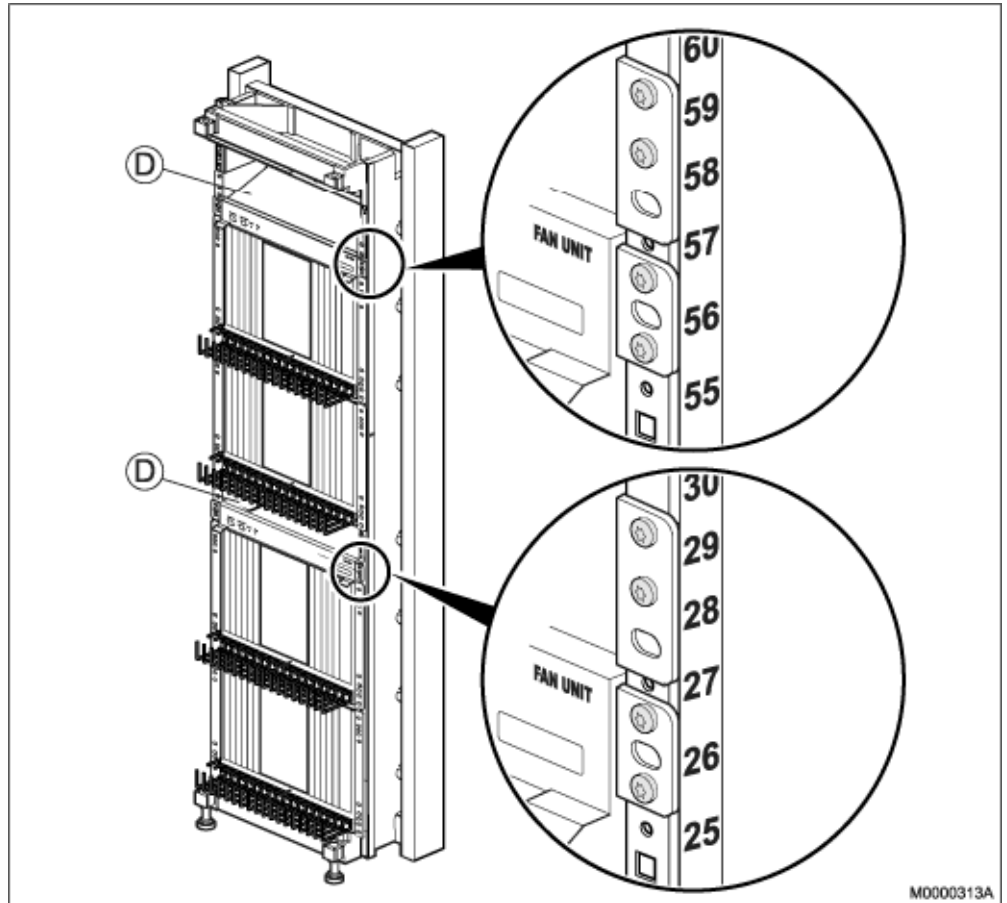

Figure 28: A four MX-ONE Classic Rack

When installing a four-MX-ONE Classic-equipped exchange cabinet (2 x subrack A+B or A+A) without internal power and batteries, two fan units with upper air plates (D) are mounted in the cabinet.

2.8 INSTALLING SERVERS

Install the standard servers in a standard server cabinet (locally sourced). Install the 1U chassis including the ASU in a BYB 501 cabinet.

For the installation procedure for the standard server cabinet, refer to manufacturer instructions.

2.8.1 INSTALLING MX-ONE 1U CHASSIS

This section describes how to install the 1U chassis, MX-ONE 1U in the BYB 501 cabinet. Additional 1U chassis can be installed directly above the first one in the same way as the first 1U chassis.

Use the following mounting set to install the MX-ONE 1U chassis in the cabinet.

Table 14 Mounting Set for 1U chassis, MX-ONE Service Node

NTM 144 264 Mounting set			
Pos	Title/Function	Product Number	Quantity
C	SCREW M 6X16	78/SBA 121 060/0160	4
A	CAPTIVE NUT M6	SBM 173 060/03	4

To install the 1U chassis in the cabinet, perform the following steps:

Note: Power inlets are positioned on rear side of the chassis. Secure that rear side is accessible after mounting, or insert the 48V and/or the 115/230V Mains cable before mounting in the rack. Fasten all power cables by Cable tie to avoid disconnection. See Figure 30:Secure Main cables on page 37.

Note: This equipment have to be connected to protective ground. Connect a grounding cable to the bracket at the earthing point, close to the earthing symbol located at the rear side of the chassis. See Figure 30:Secure Main cables on page 37.

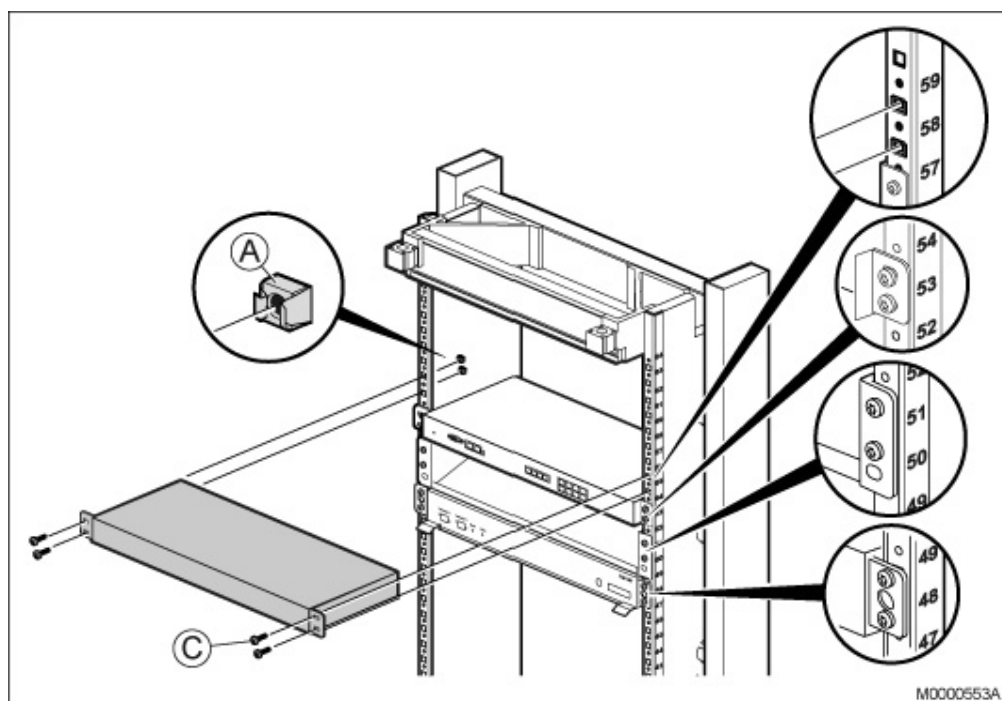
**Figure 29: Installing MX-ONE 1U chassis**

1. Mount four captive nuts (A) (see 2.3 Installing Supporting Captive Nuts on page 18) according to the number positions shown, see on page 36.
2. Fasten the 1U chassis to the four captive nuts in the cabinet, using the four screws (C).
3. If required, install additional 1U chassis directly above the first one in the next available cabinet position. No gap is needed between the units.

Note: Do not obstruct the cooling air flow, which goes from right to left in the MX-ONE Lite (3U) and MX-ONE 1U subrack.



Figure 30: Secure Main cables

2.9

INSTALLING MX-ONE LITE 3U

This section describes the installation of MX-ONE Lite subracks in the BYB 501 cabinet.

Use the following mounting set to install the MX-ONE Lite subrack in the cabinet.

Note: 110/240V Mains power inlets are positioned on rear side of the MX-ONE Lite. Secure that rear side is accessible after mounting, or insert the Mains cable before mounting in the rack. Fasten all power cables by Cable tie to avoid disconnection. See Figure 30:Secure Main cables on page 37.

Note: This equipment have to be connected to protective ground. Connect a grounding cable to the bracket at the earthing point, close to the earthing symbol located at the rear side of the chassis. For an example see Figure 30:Secure Main cables on page 37.

Table 15 Mounting Set for MX-ONE Lite subrack

NTM 144 264 Mounting set			
Pos.	Title/Function	Product Number	Quantity
C	SCREW M 6X16	78/SBA 121 060/0160	4
A	CAPTIVE NUT M6	SBM 173 060/03	4

To install the MX-ONE Lite in the cabinet, perform the following steps:

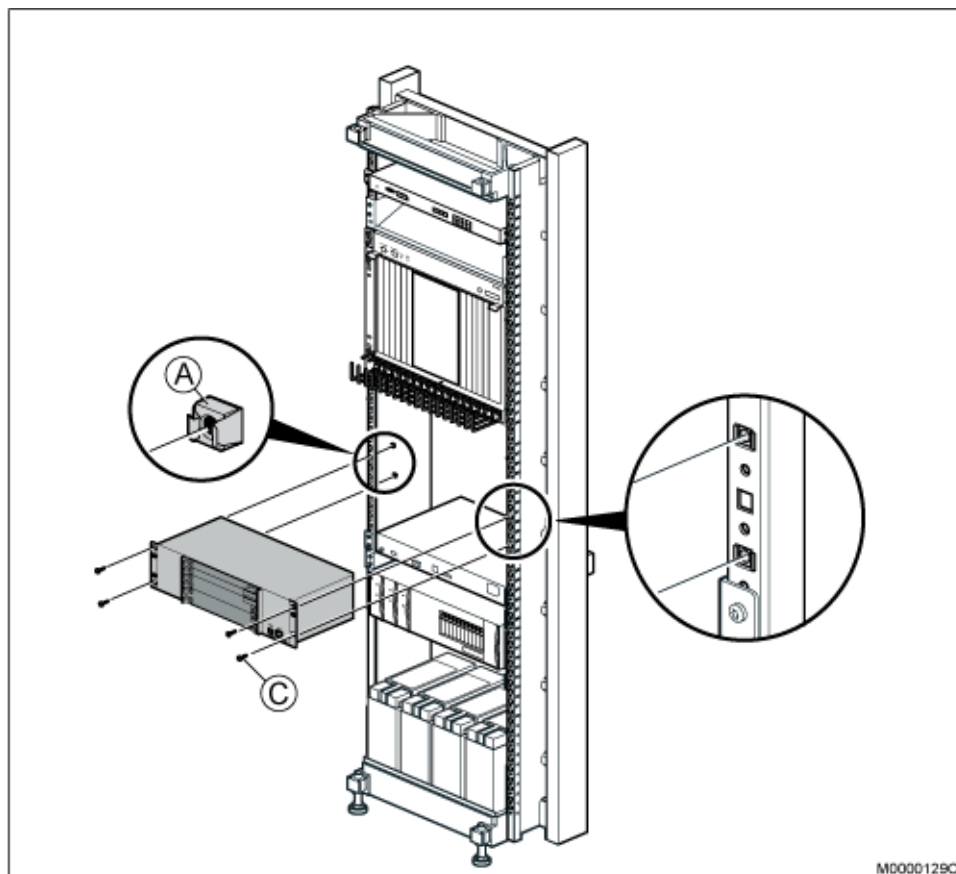

Figure 31: Installing MX-ONE Lite subrack

1. Mount four captive nuts (A) (2.3 Installing Supporting Captive Nuts on page 18) at a chosen position. The MX-ONE Lite has mounting holes to fit both metric and inch measured cabinets.
2. Fasten the MX-ONE Lite to the four captive nuts in the cabinet, using the four screws (C), see on page 38.
3. Additional MX-ONE Lite units can be mounted directly above or below the first one. No gap is needed between the units as they have their own cooling systems.

Note: Do not obstruct the cooling air flow, which goes from right to left in the MX-ONE Lite and Slim subrack.

2.10

INSTALLING A CABINET SHELF

This section describes the installation of a cabinet shelf in the cabinet.

Note: The cabinet shelf is optional, and could be used for a portable computer or a heavy unit i.e the 2U Power unit.

Table 16 Cabinet Shelf

86/BYB 501/2 Cabinet Shelf			
Pos	Title/Function	Product Number	Quantity
D	SHELF	SXA 210 44/2	1

86/BYB 501/2 Cabinet Shelf			
Pos	Title/Function	Product Number	Quantity
E	FIXING BRACKET (factory mounted)	SXA 123 0417/1	2
F	SCREW M 4X8 (factory mounted)	24/SBF 228 040/0080	4
G	SLIDE	SXA 123 0320/2	2
A	CAPTIVE NUT M 6	SBM 173 060/03	2
C	SCREW M 6X16	03/SBA 121 060/0160	2

To install the cabinet shelf, see on page 39, and perform the following steps:

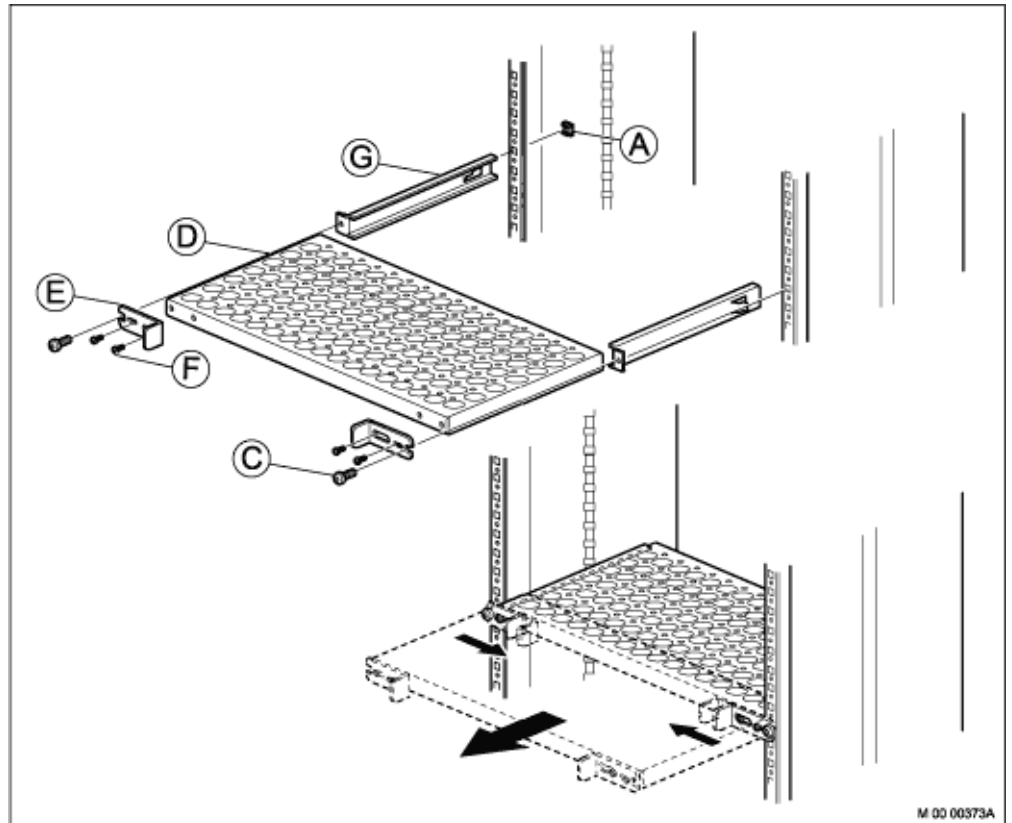

Figure 32: Installing Cabinet Shelf

1. Mount two captive nuts (A) (2.4 Installing Supporting Captive Nuts on page 22) at the chosen position for the shelf.
2. Fasten the two slides (G) to the two captive nuts in the cabinet using the two screws (C) and then loosen the screws.
3. Loosen the four screws (F) slide the two fixing brackets (E) against each other on the shelf and push the shelf (D) into the two slides (G).
4. Slide the two fixing brackets (E) outwards behind the two screws (C), then tighten the four screws (F).
5. Finally fasten the shelf (D) by tighten the two screws (C).

2.11

LABELING

Before cabling the cabinet it is necessary to label the media gateway parts used per Server, using the labels provided in label sets SVH 277 02/1 - /5, see 17 Gateway Labels on page 40. The cabinet must be labeled with the number of Servers that is installed in the cabinet. It is recommended to label the following items:

- Cabinet
- MX-ONE 1U
- MX-ONE Lite (3U-chassis)
- MX-ONE Classic (7U-chassis)
- AC/DC
- Other servers

Table 17 Gateway Labels

Product Number	Server Number
SVH 277 02/1	1 - 10
SVH 277 02/2	11 - 20
SVH 277 02/3	21 - 30
SVH 277 02/4	31 - 40
SVH 277 02/5	41 - 124 (one for each Server)

For recommended labeling in BYB 501, see on page 40.

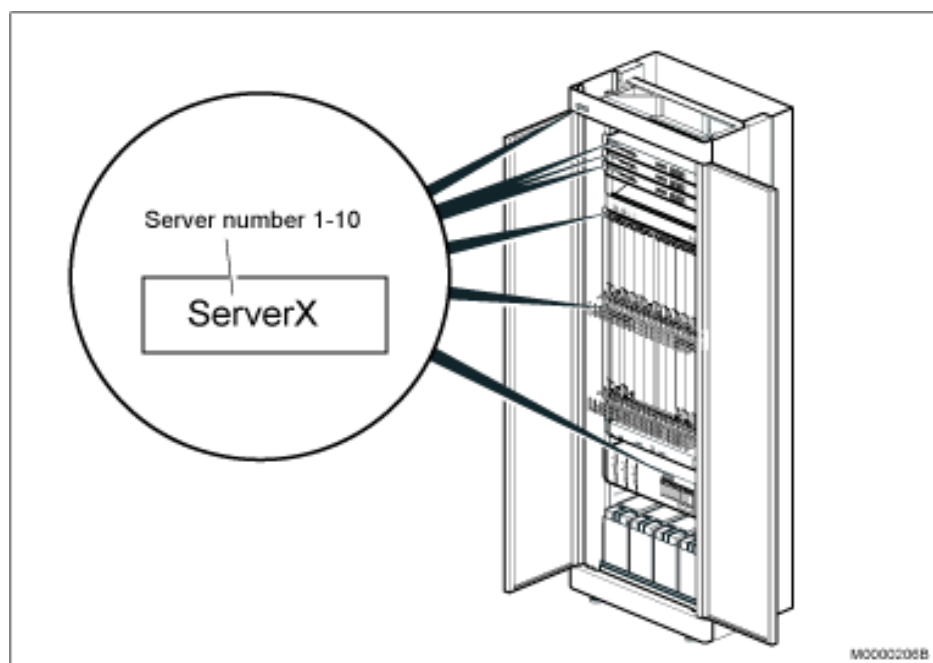

Figure 33: Labeling of BYB 501

2.11.1

LABELING CABLES

For labeling of cables see document 21/1531-ASP11301.

2.11.2

WARNING LABEL, ENERGY HAZARD

The warning label, energy hazard (SVB 131 75) is for indoor use on aluminum, steel, or rigid plastic surface. It is made of self adhesive plastic material and not removable. Fasten the warning label below the circuit breakers on the front of the AC/DC unit, see Figure 34:Warning Label SVB 131 75 on page 41.

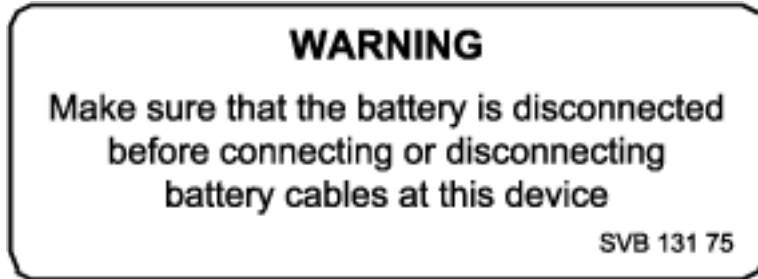

Figure 34: Warning Label SVB 131 75

2.11.3

WARNING LABEL, PARALLEL CONNECTION OF BATTERIES

The warning label, parallel connection of batteries (SVB 131 70) is for indoor use on aluminum, steel, or rigid plastic surface. It is made of self adhesive plastic material and not removable. Fasten three (3) warning labels, one on the right-hand side battery, and two at the bottom of the cabinet, see on page 23 and see on page 41.

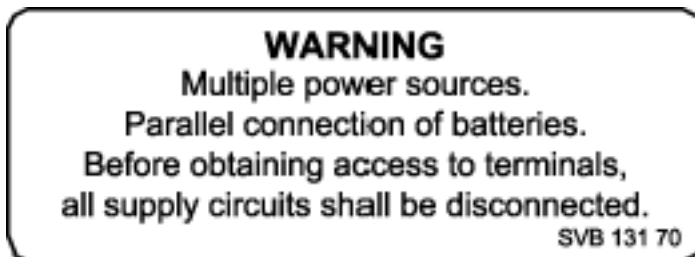

Figure 35: Warning Label SVB 131 70

Note: Battery warning labels are also available in German and French.