

# Pick-to-Light Solutions Kit

## Instruction Manual

Original Instructions  
214476 Rev. A  
12 December 2019  
© Banner Engineering Corp. All rights reserved



214476

# Contents

|  |           |
|--|-----------|
| <b>1 Interface Information</b>                         | <b>3</b>  |
| 1.1 Device Identification                              | 3         |
| 1.1.1 Display Current IDs                              | 4         |
| 1.1.2 Assign a Group of IDs                            | 5         |
| 1.1.3 Assign a Single Device ID                        | 5         |
| 1.2 Recipe Setup                                       | 6         |
| 1.2.1 Manual Teach                                     | 7         |
| 1.3 Recipe Execution                                   | 7         |
| 1.4 Utilities  | 8         |
| 1.4.1 Connectivity Test                                | 8         |
| 1.4.2 Light Configuration                              | 9         |
| 1.4.3 PICK-IQ Registers                                | 10        |
| 1.4.4 HMI Setup  | 10        |
| <b>2 System Information</b>                            | <b>11</b> |
| 2.1 Definition of PICK-IQ™                             | 11        |
| 2.2 Understanding the Application Control              | 11        |
| 2.3 Solution Components                                | 12        |
| 2.3.1 DXM700   | 12        |
| <b>3 Compatible Hardware</b>                           | <b>13</b> |
| 3.1 PTL110   | 13        |
| <b>4 Accessories</b>                                   | <b>14</b> |
| 4.1 Cordsets   | 14        |
| <b>5 Extending Functionality</b>                       | <b>16</b> |
| <b>6 Product Support and Maintenance</b>               | <b>17</b> |
| 6.1 Troubleshooting                                    | 17        |
| 6.2 Recommended Resources                              | 17        |
| 6.3 Contact Us   | 17        |
| 6.4 Banner Engineering Corp Limited Warranty           | 18        |
| 6.5 Banner Engineering Corp. Software Copyright Notice | 18        |
| 6.6 FCC Part 15 and CAN ICES-3 (B)/NMB-3(B)            | 18        |

# 1 Interface Information

The Pick-to-Light Solutions Kit for improved productivity in picking systems is an easy-to-use solution to reduce error during the assembly process. It comes with a pre-programmed DXM700 and HMI with touch screen for pick-to-light system setup and integration. The Pick-to-Light Solutions Kit harnesses the power of all models of PICK-IQ™ devices, is simple to mount and install, and solves more applications with flexible pick functionality. Functionality is divided into the following categories:

## Device Identification

View and update device IDs.

## Recipe Setup

Create pick recipes by interactively touching the devices in their pick order. Recipes can also be entered using the touch screen.

## Recipe Execution

Execute and change between recipes.

## Utilities

Tools to check the status of devices and to add customized behaviors.

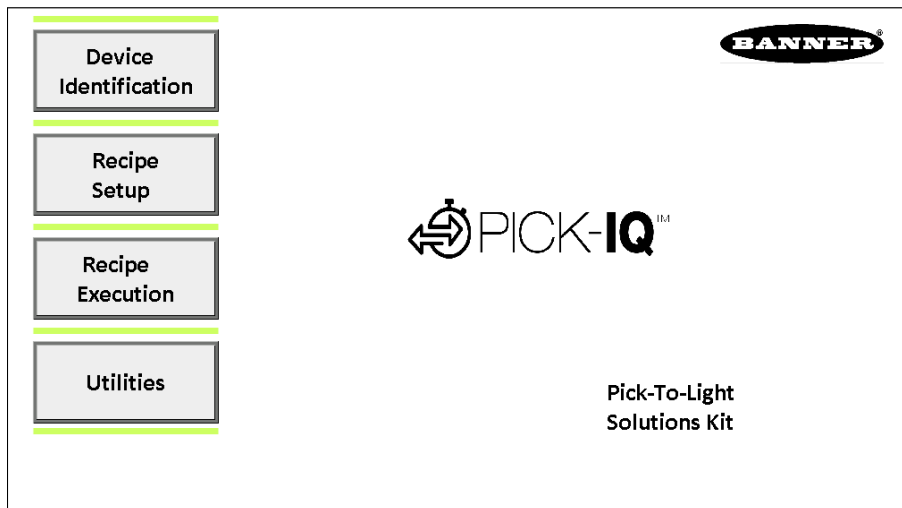

Figure 1. Main Menu

## 1.1 Device Identification

Each PICK-IQ device on a network should be assigned a unique numeric identifier so that it can be controlled by the Pick-to-Light Solutions Kit. This is referred to as the *device ID* of a pick-to-light node and serves as the name for the device on the network. The identifiers can be assigned into the range between 2 and 99. The meaning of the number is not important to the solutions kit, and any numbering scheme that is meaningful to the user can be chosen. Numbering them in their physical order is a common choice. PICK-IQ devices have a factory default device ID of 1.

Pressing **Device Identification** brings the user to a submenu for viewing or modifying device ID assignments.

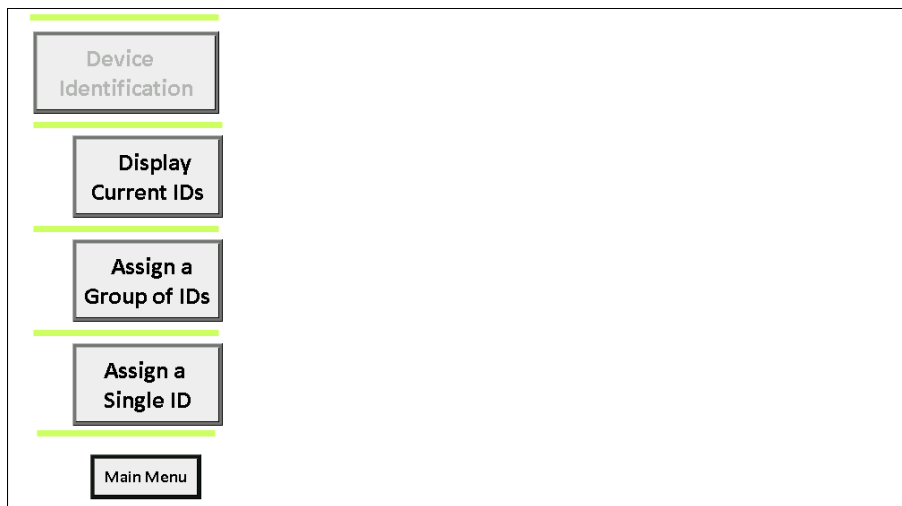

Figure 2. Device Identification Submenu

### 1.1.1 Display Current IDs

From the Device Identification submenu, press **Display Current IDs** to bring up the Display Current IDs screen.

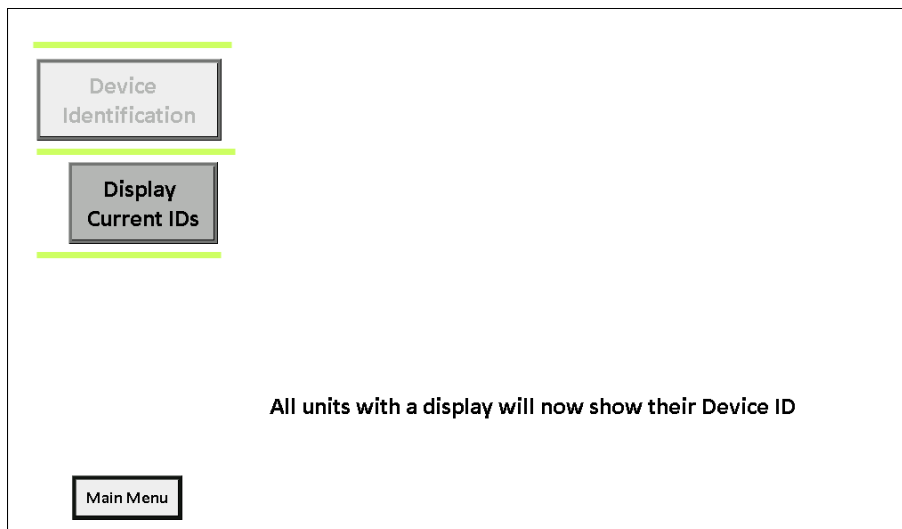

Figure 3. Display Current IDs Screen

1. Press **Display Current IDs** again to put the device indicators into a fast blue flash. This also disables the input actuators (optical or touch). The Device ID is shown if the device has a display.
2. Press **Display Current IDs** again to turn off this mode.

## 1.1.2 Assign a Group of IDs

From the Device Identification menu, press **Assign a Group of IDs** to bring up the Assign a Group of IDs screen. This screen is used to interactively assign device IDs to PICK-IQ devices. This can only be used to give device IDs to PICK-IQ devices that contain an actuator (push button, touch button, or optical sensor). For indicator-only models, see [Assign a Single Device ID](#) on p. 5.

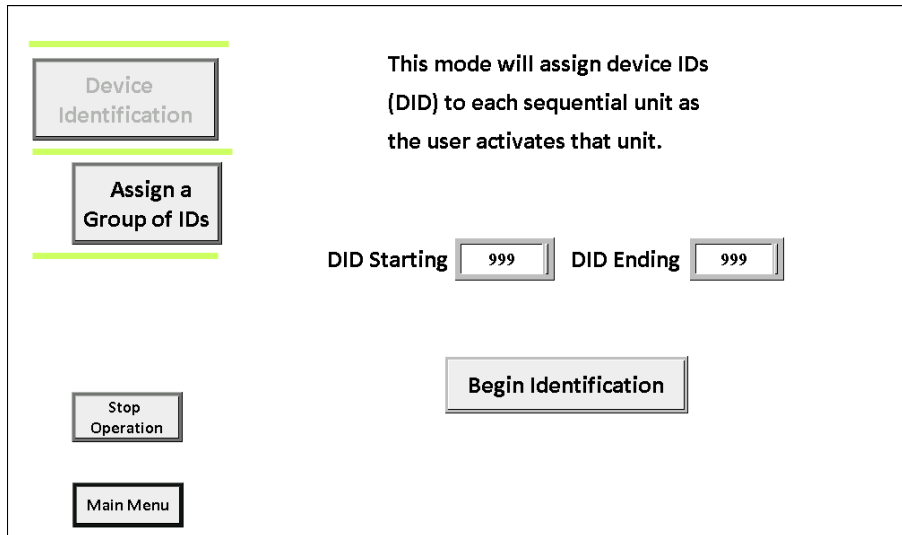

Figure 4. Assign a Group of IDs Screen

This functionality is used to set IDs to all devices in the network.

1. Enter the first device ID to be assigned in the **DID Starting** field.
  2. Enter the final device ID to be assigned in the **DID Ending** field.
  3. Press **Begin Identification** to start the process.
  4. Actuate each unit in turn to give it the next device ID.  
The unit flashes blue and the ID is shown on the display (where present) when it is actuated and accepts its new ID.
- The assignment process automatically ends when **DID Ending** is assigned to a device. Press **Stop Operation** to end the process early.

## 1.1.3 Assign a Single Device ID

From the Device Identification menu, press **Assign a Single ID** to bring up the Assign a Single ID screen. This screen can be used to directly assign device IDs over the network. It offers two methods of modifying IDs:

1. To modify a device whose current ID is known:

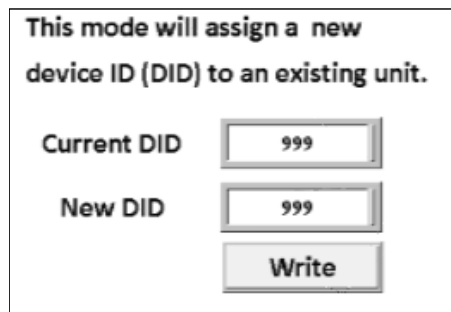

Figure 5. Modifying a Known ID

- a) Enter the ID to be modified in the **Current DID** field.
- b) Enter the replacement ID in the **New DID** field.
- c) Press **Write** to complete the update.

One use case for this would be replacing a device on the network with a new device. New PICK-IQ devices have an ID of 1, and it can be changed to another ID by entering 1 into the **Current DID** field, the desired ID into the **New DID** field, and then pressing **Write** to complete the update.

- To assign a device ID to an unknown device or to all currently connected devices:



Figure 6. Assigning an ID to an Unknown Device or to All Connected Devices

- Enter the specified device ID in the `Force DID` field.
- Press **Write** to complete the process.

One use case for this is to give an ID to a device whose current device ID is not known. Another common use for this is to assign IDs by plugging individual devices into the network one at a time, for instance when device IDs may not be in a single range.

## 1.2 Recipe Setup

A recipe describes the pick events to be taken. A pick event is when the indicator of a PICK-IQ device turns on to notify the operator where attention is needed, and waits for the operator to acknowledge that the required action has been performed by actuating the device. Each state in this process has unique customizable indication to clearly show the status of the operation.

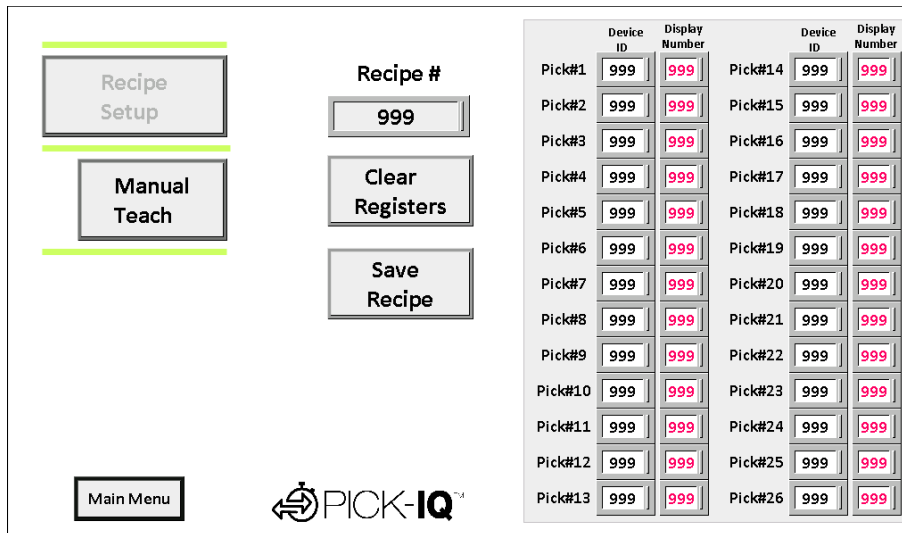

Figure 7. Recipe Setup Screen

A recipe can consist of up to 26 picks events. Each pick event is defined by the ID of the device to be activated, and optionally by a number that is shown on the device's display. A typical use for the display number is to indicate a quantity, but the number could mean anything specific to the application at hand. Any device ID can be assigned to any pick event, and the same device ID may be used multiple times.

To begin recipe creation:

- Enter the numeric identifier of the recipe in the `Recipe#` field.  
This number is used to save and load the recipe for future use.
- Define the pick events by entering each pick entry's `Device ID` and `Display Number` in their respective fields.  
The first pick entry with a device ID of 0 is used to indicate the end of the recipe.
- After the recipe is defined, press **Save Recipe** to save the recipe to the solutions kit.

Alternatively, a recipe may be created interactively using a manual teach.

If desired, press **Clear Registers** to empty the recipe.

## 1.2.1 Manual Teach

A manual teach is where the recipe is interactively defined by the user actuating the PICK-IQ devices involved in each pick event. From the Recipe Setup screen, press **Manual Teach** to enter the Manual Teach screen.

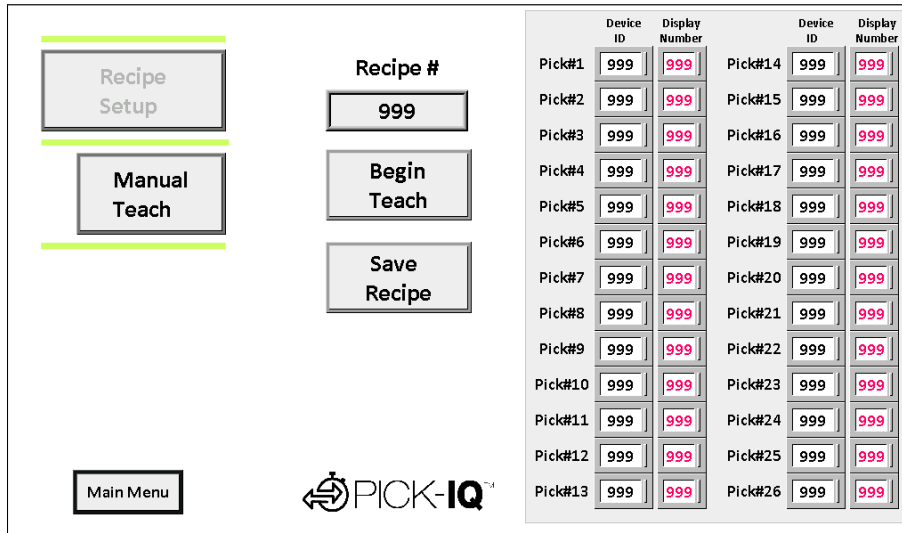
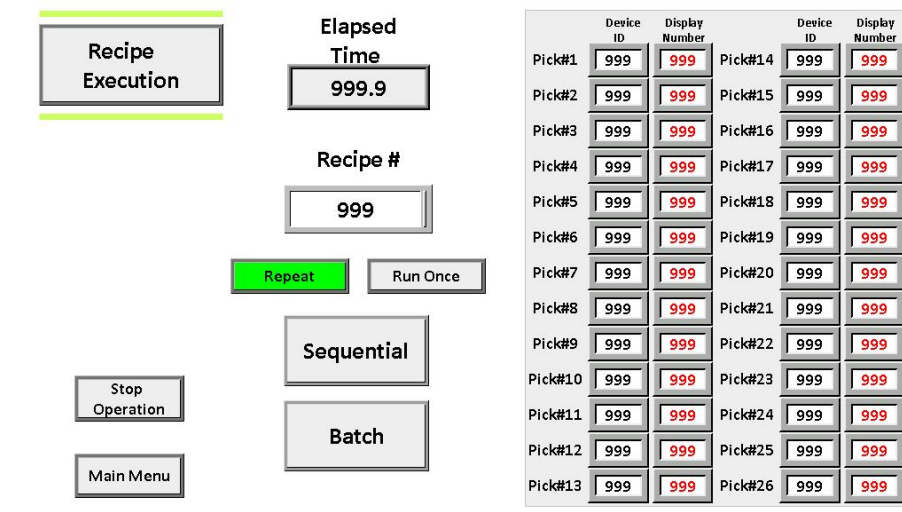

Figure 8. Manual Teach Screen

1. Press **Begin Teach**.
2. Actuate the device associated with the first pick event.  
The display number is initialized to 1. This can be increased by further actuating the device, or decreased by using the device's secondary actuation (for example, a PTL110 optical sensor).
3. Define the second pick event by actuating the next device.
4. Continue to define each subsequent pick event by actuating the devices.  
The recipe table of the Manual Teach screen updates as the recipe is being built interactively.
5. Press **Save Recipe** once the required pick events for the recipe have been defined.  
The system is now ready to run the recipes.

## 1.3 Recipe Execution

Recipe Execution is the main operating screen of the system. From this screen, the user can choose which recipe to run and how to execute it. From the main screen, press **Recipe Execution** to enter the Recipe Execution screen.



execute(#13): 1024X600

Figure 9. Recipe Execution Screen

1. Press the **Recipe#** field to load a previously saved recipe.  
The recipe's pick entries can be reviewed in the table.

2. Select one of the following:
  - Select **Run Once** to run the recipe only one time and then stop
  - Select **Repeat** to immediately restart the recipe after it completes
3. Run the recipe by choosing either **Sequential** or **Batch**.
  - A **Sequential** run causes each pick entry to occur one at a time, sequentially in their pick entry order
  - A **Batch** run causes all pick entries to be enabled at the same time



**Note:** A **Batch** run does not work for recipes with the same device ID used in multiple pick entries.

4. Press **Stop Operation** to end a recipe execution early.

## 1.4 Utilities

The Utilities menu contains additional diagnostic and configuration screens. From the main menu, press **Utilities** to enter the Utility submenu.

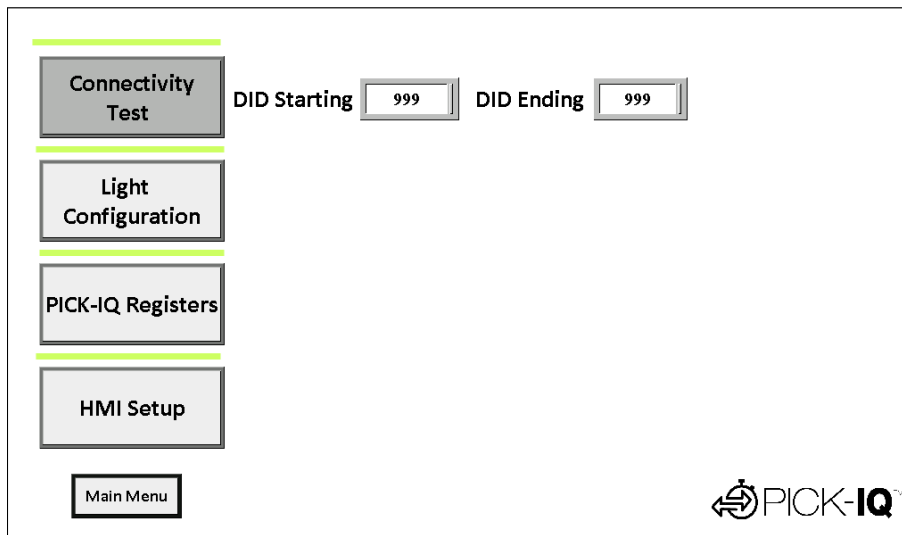

Figure 10. Utilities Submenu

### 1.4.1 Connectivity Test

From the Utilities submenu, the **Connectivity Test** offers a way to verify that the PICK-IQ devices on your network are communicating and are using the expected device IDs.



Figure 11. Connectivity Test Screen

1. Enter the starting device ID in the **DID Starting** field.
2. Enter the last device ID in the **DID Ending** field.
3. Press **Connectivity Test**.

Each device in the device ID range flashes in sequence. Duplicate or missing device IDs cause a noticeable pause in the sequence of flashing devices due to a timeout.

Press **Connectivity Test** again to end the test.

## 1.4.2 Light Configuration

The Light Configuration screen allows indicator behavior customization for the devices on the PICK-IQ network. From the Utilities menu, press **Light Configuration** to go to the Light Configuration screen.

The screenshot shows the Light Configuration screen with the following sections:

- State Selection:** Buttons for Wait (highlighted in green), Mis-Pick, Job, Acknowledge, and Acknowledge2.
- Force State:** Buttons for Wait, Job, Update, Read, and Write.
- Animation:**
  - Animation Style: Half Top, Half Bottom
  - Number of Choices: 9 to chose from
  - Animation Speed: Fast
  - Animation Pattern: Normal
  - Animation Direction: Clockwise
- Color1:**
  - Color: Spring Green
  - Number of Choices: 14 to chose from
  - Intensity: Medium
- Color2:**
  - Color: Spring Green
  - Number of Choices: 14 to chose from (Only applies if the Animation requires)
  - Intensity: Medium
- Delays:**
  - Visible On Delay(ms): 99999
  - Visible Off Delay(ms): 99999
- Navigation:** Defaults and Main Menu buttons.

Figure 12. Light Configuration Screen

- The **Wait** state is used to define the behavior when a device is idle.
- The **Mis-Pick** state is used when a device has been actuated but it was not on an active pick event.
- The **Job** state defines how the lights look when they are associated with an active pick event, waiting for the user to process the event.
- The **Acknowledge** state is used when an active device is actuated by the user.
- **Acknowledge2** is an advanced configuration that can be used to differentiate the primary actuator from the secondary actuator.

See [Understanding the Application Control](#) on p. 11 for description of the states.

- To define the animation of a state:
  - Select the desired state by pressing the associated button.
  - Press **Read** to see the current values for the state.
  - Modify the behavior of the state as desired.
  - When finished, press **Write** to send the current setting to all devices on the network.
- To preview Wait or Job states on the network, press the associated **Force State** button to simulate a condition.
- To start over, press the **Defaults** button to restore the default animation behaviors.

More information on how these settings affect the devices can be found in the PICK-IQ Instruction Manual ([206185](#)).

### 1.4.3 PICK-IQ Registers

The PICK-IQ Registers is an advanced configuration screen that gives access to all functionality of the PICK-IQ protocol—for example, adjusting the sensitivity of the touch button to allow work with thick gloves. From the Utilities menu, press **PICK-IQ Registers** to go to the PICK-IQ Registers screen.

Figure 13. PICK-IQ Registers

Behind the scenes, many of the other screens are using the functionality of the PICK-IQ Registers. To send a message to a PICK-IQ device:

1. Enter its device ID in the `Device ID` field.
2. Enter the number of registers that you wish to communicate with in the `Number of Registers` field.
3. Enter the starting register address in the `Starting Register Address` field.
4. Press one of the following:

- Press **Read** to load the current values from the device into the `ReadData` column
- Press **Write** to send the values in the `WriteData` column to the device

Using a Device ID of 4096 allows the Write to be broadcasted to all devices. Using a Device ID of 199 interacts with the local registers of the DXM700 controller.

More information on the PICK-IQ protocol can be found in the PICK-IQ Instruction Manual ([206185](#)) and PICK-IQ Device Register Map ([209995](#)).



**Note:** The register address expects an address with a 1 offset, as is common in PLCs.

### 1.4.4 HMI Setup

Advanced configurations of the HMI screen are available for future upgrades. These should not be used without specific directions because it may limit the functionality of the system.

## 2 System Information

### 2.1 Definition of PICK-IQ™

The Pick-to-Light Solutions Guide allows users to interface with PICK-IQ™ products. PICK-IQ™ is a modified usage of the Modbus RTU protocol that allows for quick responses in large serial networks. Each Pick-to-Light device is assigned a common ID and a unique device ID. This allows a unique device to be written with specific information, but a controller to only monitor a single ID point for the speed of a two-node network.

### 2.2 Understanding the Application Control

Pick-to-Light, also known as light-directed or light-guided picking, refers to the use of colored LED indicators to guide assemblers and operators to the correct part or product location. Pick-to-Light solutions can also be used to indicate the number of parts to pick and proper pick order.

These solutions make manual picking processes faster and more accurate in a wide variety of applications including assembly, kitting, and order fulfillment.

The four main states of a pick device are:



Figure 14. PTL110 Pick-to-Light Sensor

#### Wait State

The device is either inactive or the bin is not selected in the current pick group (default = color and animation off).

#### Mispick State

While in Wait State, when the primary or secondary sensor becomes active, the state changes to Mispick after the on-delay is met, and stays on for the duration of the sensor actuation. Mispick on-delay is used to filter unintended activations (default = red flash).

#### Job State

When the Job Status is not zero, the individual device goes into the Job State, indicating that it is in the current pick routine. Animation, color, intensity, speed, pattern, and direction are controlled for maximum efficiency (default = green steady).

#### Acknowledge State

The Acknowledge State is activated when either of the sensors are actuated in the Job State. A secondary Acknowledge State (2) is included to distinguish between touch and optical sensor interaction (default = yellow steady).

| Primary Output Logic Tables |                               |                           |
|-----------------------------|-------------------------------|---------------------------|
| Job Input Logic             | Touch or Sensor Not Activated | Touch or Sensor Activated |
| Not Active                  | Wait State                    | Mispick State             |
| Active                      | Job State                     | Acknowledge State         |

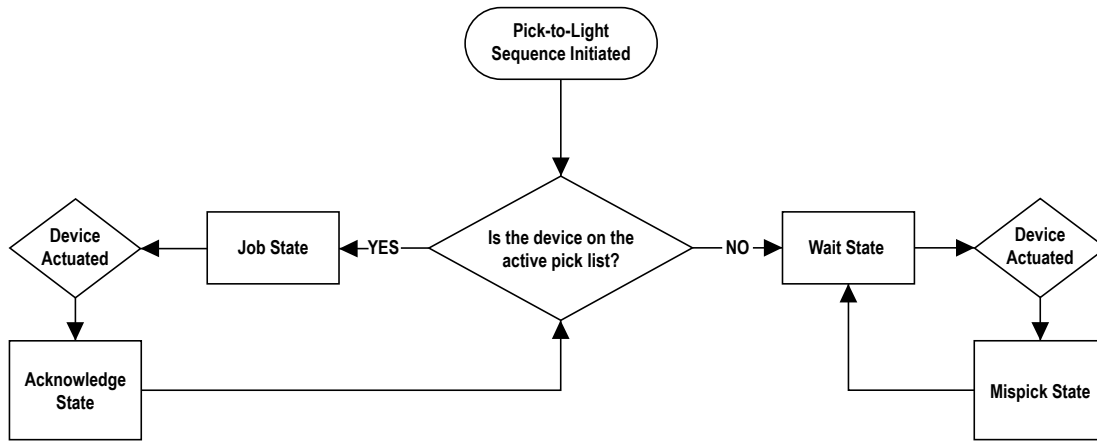

Figure 15. Pick-to-Light Flowchart

## 2.3 Solution Components

### 2.3.1 DXM700



Figure 16. DXM700-B1-PTL

The DXM700 Controller with the ScriptBasic Solution completes all of the low-level logic for a Pick-to-Light device and provides access to supervisory systems. The internal Modbus master controls the main Pick-to-Light network, while the interface to the control system is either through an ethernet port or a high-speed serial port.

| Model         | Description   |
|---------------|---|
| DXM700-B1-PTL | Pre-Programmed DXM700 for Pick-to-Light Integration |

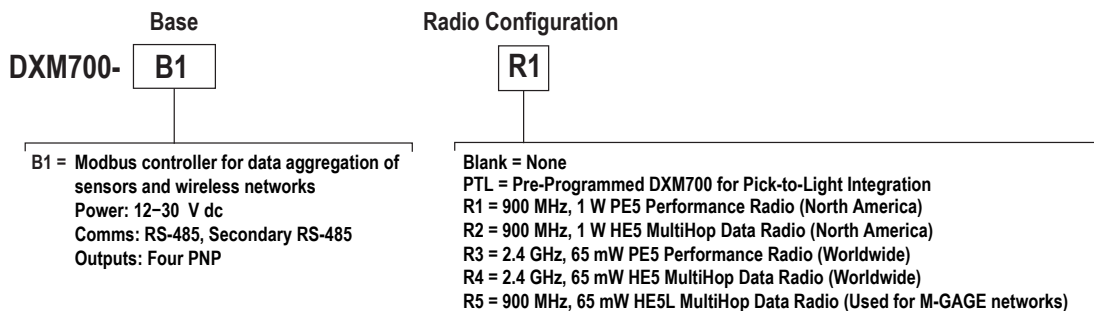

Reference the following documents for further information about the DXM700:

- DXM700-B1 Wireless Controller Datasheet Original document PN [207893](#)
- DXM700-Bx Wireless Controller Instruction Manual Original document PN [207894](#)

## 3 Compatible Hardware

### 3.1 PTL110

The PTL110 with PICK-IQ™ is an indicator with the ability to change colors and animation styles to bring active attention to a bin. The addition of the optional 3-digit LED display allows for quantities or scrolling messages. Optional inputs can be a touch sensor on the indicator and/or a fixed-field sensor in the base. Low power methods allow for 64 devices to be wired on one 24 V DC power source.

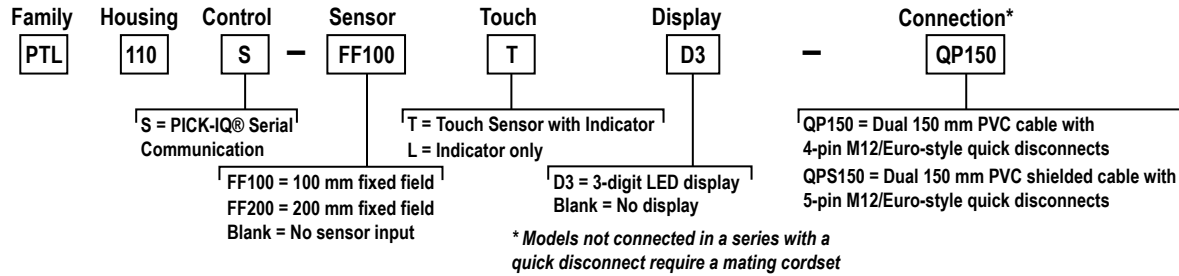

**Note:** Address initialization requires a touch sensor. Adding the display option allows you to view the device ID, which makes set-up and maintenance easy.

Reference the following documents for further information about the PTL110:

|   |   |
|---|---|
| PTL110S Pick-to-Light -- Datasheet          | Original document PN <a href="#">206183</a> |
| PTL110S Pick-to-Light -- Instruction Manual | Original document PN <a href="#">206185</a> |
| PTL110S Pick-to-Light Device Registers      | Original document PN <a href="#">209995</a> |

# 4 Accessories

## 4.1 Cordsets

| 5-Pin M12/Euro-Style Cordsets with Shield—Single Ended |              |          |            |  |
|--|--------------|----------|------------|--|
| Model  | Length       | Style    | Dimensions | Pinout (Female)  |
| MQDC-STP-506   | 2 m (6.5 ft) | Straight |            | <p>1 = Brown<br/>2 = White<br/>3 = Blue<br/>4 = Black<br/>5 = Shield</p> |
| MQDC-STP-515   | 5 m (15 ft)  |          |            |  |
| MQDC-STP-530   | 9 m (30 ft)  |          |            |  |

| 4-Pin Threaded M12/Euro-Style Cordsets—Single Ended |                |             |            |   |
|---|----------------|-------------|------------|---|
| Model   | Length         | Style       | Dimensions | Pinout (Female)   |
| MQDC-406  | 1.83 m (6 ft)  | Straight    |            | <p>1 = Brown<br/>2 = White<br/>3 = Blue<br/>4 = Black</p> |
| MQDC-415  | 4.57 m (15 ft) |             |            |   |
| MQDC-430  | 9.14 m (30 ft) |             |            |   |
| MQDC-450  | 15.2 m (50 ft) |             |            |   |
| MQDC-406RA  | 1.83 m (6 ft)  | Right-Angle |            |   |
| MQDC-415RA  | 4.57 m (15 ft) |             |            |   |
| MQDC-430RA  | 9.14 m (30 ft) |             |            |   |
| MQDC-450RA  | 15.2 m (50 ft) |             |            |   |

| 4-Pin Threaded M12/Euro-Style Cordsets—Double Ended |                |                                   |   |        |
|---|----------------|-----------------------------------|---|--------|
| Model   | Length         | Style                             | Dimensions  | Pinout |
| MQDEC-401SS   | 0.31 m (1 ft)  | Male Straight/<br>Female Straight |   | Female |
| MQDEC-403SS   | 0.91 m (3 ft)  |                                   |   |        |
| MQDEC-406SS   | 1.83 m (6 ft)  |                                   |   | Male   |
| MQDEC-412SS   | 3.66 m (12 ft) |                                   |   |        |
| MQDEC-420SS   | 6.10 m (20 ft) |                                   |   |        |
| MQDEC-430SS   | 9.14 m (30 ft) |                                   |   |        |
| MQDEC-450SS   | 15.2 m (50 ft) |                                   | <p>1 = Brown<br/>2 = White<br/>3 = Blue<br/>4 = Black</p> |        |

| 4-Pin Threaded M12/Euro-Style Cordsets with Shield— Double-Ended |              |                                     |            |        |   |
|--|--------------|-------------------------------------|------------|--------|---|
| Model  | Length       | Style                               | Dimensions | Pinout | Key   |
| MQDEC-STP-501SS-FF   | 0.3 m (1 ft) | Female Straight/<br>Female Straight |            |        | 1 = Brown<br>2 = White<br>3 = Blue<br>4 = Black<br>5 = Shield |
| MQDEC-STP-501SS-MM   | 0.3 m (1 ft) | Male Straight/Male<br>Straight      |            |        |   |

## 5 Extending Functionality

The Pick-to-Light Solutions Kit offers a way for users to get a system up and running, with minimal need for programming knowledge. The solution kit offers some level of customization by way of the PICK-IQ registers. However, some pick-to-light solutions need more flexibility, such as multiuser picking, custom user interfaces, integration with ERP system or other networked equipment, etc. This Pick-to-Light Solutions Kit is built on top of the DXM700-B1-PTL controller that is preconfigured to solve pick-to-light problems using PICK-IQ devices. The solutions kit only uses a subset of the functionality offered in the DXM700-B1-PTL. For users who want to integrate a PICK-IQ system with their own infrastructure, the DXM700-B1-PTL offers a solution that handles some of the pick logic programming for the users. Banner provides a solution guide ([214046](#)) with instruction and best practices for using PICK-IQ with the DXM700-B1-PTL.

The PICK-IQ system is fully compatible with the industrial communication protocol Modbus RTU. It can fit into any supporting infrastructure for maximum control and customization. When needed, controllers such as the DXM can serve as a protocol converter between Modbus RTU and other wired or wireless communications technologies.

## 6 Product Support and Maintenance

### 6.1 Troubleshooting

| Issue  | Method                          | Solution  |
|--|---------------------------------|---|
| Units are not responding as expected           | <b>Verify Device IDs</b>        | Make sure that each PICK-IQ device has the expected ID. This can be reviewed by <b>Device Identification &gt; Display Current IDs</b> .   |
| Device IDs on the network are unknown          | <b>Reset Device IDs</b>         | Use <b>Device Identification &gt; Assign a Single ID &gt; Force DID: 1 &gt; Write</b> to reset all connected device IDs to their factory default of ID 1.   |
| Network is not communicating as expected       | <b>Verify Communications</b>    | Use <b>Utilities &gt; Connectivity Test</b> to spot any problem units.  |
| Lights are not showing as expected             | <b>Reset Indicator Settings</b> | Use <b>Utilities &gt; Light Configuration &gt; Defaults</b> to restore the lights to the standard indication values.  |
| Want to reset to default settings              | <b>Factory Reset</b>            | Use PICK-IQ's Restore Factory Defaults feature to reset all settings of all devices to their default settings. Navigate to <b>Utilities &gt; PICK-IQ Registers</b> and enter the following: <ul style="list-style-type: none"> <li>• Device ID: 4096</li> <li>• Number of Registers: 3</li> <li>• Starting Register Address: 6601</li> <li>• WriteData1: 1</li> <li>• WriteData2: 43690</li> <li>• WriteData3: 21845</li> </ul> Press <b>Write</b> to complete the factory reset. |
| Want to put the system back into a known state | <b>Power Cycle</b>              | Remove power from the entire system, wait a couple seconds, and then reapply power.   |

### 6.2 Recommended Resources

|  |   |
|--|---|
| PTL110S Pick-to-Light Device Register Map          | Original document PN <a href="#">209995</a> |
| PTL110S Pick-to-Light Devices - Instruction Manual | Original document PN <a href="#">206185</a> |
| DXM Configuration Software V4 - Instruction Manual | Original document PN <a href="#">209933</a> |
| DXM700 Controller - Instruction Manual             | Original document PN <a href="#">207894</a> |
| ScriptBasic for DXM Controller                     | Original document PN <a href="#">186221</a> |
| DXM Controller Protocol                            | Original document PN <a href="#">186221</a> |

### 6.3 Contact Us

Banner Engineering Corp. headquarters is located at:

9714 Tenth Avenue North  
 Minneapolis, MN 55441, USA  
 Phone: + 1 888 373 6767

For worldwide locations and local representatives, visit [www.bannerengineering.com](http://www.bannerengineering.com).

## 6.4 Banner Engineering Corp Limited Warranty

---

Banner Engineering Corp. warrants its products to be free from defects in material and workmanship for one year following the date of shipment. Banner Engineering Corp. will repair or replace, free of charge, any product of its manufacture which, at the time it is returned to the factory, is found to have been defective during the warranty period. This warranty does not cover damage or liability for misuse, abuse, or the improper application or installation of the Banner product.

**THIS LIMITED WARRANTY IS EXCLUSIVE AND IN LIEU OF ALL OTHER WARRANTIES WHETHER EXPRESS OR IMPLIED (INCLUDING, WITHOUT LIMITATION, ANY WARRANTY OF MERCHANTABILITY OR FITNESS FOR A PARTICULAR PURPOSE), AND WHETHER ARISING UNDER COURSE OF PERFORMANCE, COURSE OF DEALING OR TRADE USAGE.**

This Warranty is exclusive and limited to repair or, at the discretion of Banner Engineering Corp., replacement. **IN NO EVENT SHALL BANNER ENGINEERING CORP. BE LIABLE TO BUYER OR ANY OTHER PERSON OR ENTITY FOR ANY EXTRA COSTS, EXPENSES, LOSSES, LOSS OF PROFITS, OR ANY INCIDENTAL, CONSEQUENTIAL OR SPECIAL DAMAGES RESULTING FROM ANY PRODUCT DEFECT OR FROM THE USE OR INABILITY TO USE THE PRODUCT, WHETHER ARISING IN CONTRACT OR WARRANTY, STATUTE, TORT, STRICT LIABILITY, NEGLIGENCE, OR OTHERWISE.**

Banner Engineering Corp. reserves the right to change, modify or improve the design of the product without assuming any obligations or liabilities relating to any product previously manufactured by Banner Engineering Corp. Any misuse, abuse, or improper application or installation of this product or use of the product for personal protection applications when the product is identified as not intended for such purposes will void the product warranty. Any modifications to this product without prior express approval by Banner Engineering Corp will void the product warranties. All specifications published in this document are subject to change; Banner reserves the right to modify product specifications or update documentation at any time. Specifications and product information in English supersede that which is provided in any other language. For the most recent version of any documentation, refer to: [www.bannerengineering.com](http://www.bannerengineering.com).

For patent information, see [www.bannerengineering.com/patents](http://www.bannerengineering.com/patents).

## 6.5 Banner Engineering Corp. Software Copyright Notice

---

This software is protected by copyright, trade secret, and other intellectual property laws. You are only granted the right to use the software and only for the purposes described by Banner. Banner reserves all other rights in this software. For so long as you have obtained an authorized copy of this software directly from Banner, Banner grants you a limited, nonexclusive, nontransferable right and license to use this software.

You agree not to use, nor permit any third party to use, this software or content in a manner that violates any applicable law, regulation or terms of use under this Agreement. You agree that you will not reproduce, modify, copy, deconstruct, sell, trade or resell this software or make it available to any file-sharing or application hosting service.

**Disclaimer of Warranties.** Your use of this software is entirely at your own risk, except as described in this agreement. This software is provided "AS-IS." To the maximum extent permitted by applicable law, Banner, its affiliates, and its channel partners disclaim all warranties, expressed or implied, including any warranty that the software is fit for a particular purpose, title, merchantability, data loss, non-interference with or non-infringement of any intellectual property rights, or the accuracy, reliability, quality or content in or linked to the services. Banner and its affiliates and channel partners do not warrant that the services are secure, free from bugs, viruses, interruption, errors, theft or destruction. If the exclusions for implied warranties do not apply to you, any implied warranties are limited to 60 days from the date of first use of this software.

**Limitation of Liability and Indemnity.** Banner, its affiliates and channel partners are not liable for indirect, special, incidental, punitive or consequential damages, damages relating to corruption, security, loss or theft of data, viruses, spyware, loss of business, revenue, profits, or investment, or use of software or hardware that does not meet Banner minimum systems requirements. The above limitations apply even if Banner and its affiliates and channel partners have been advised of the possibility of such damages. This Agreement sets forth the entire liability of Banner, its affiliates and your exclusive remedy with respect to the software use. You agree to indemnify and hold Banner and its affiliates and channel partners harmless from any and all claims, liability and expenses, including reasonable attorney's fees and costs, arising out of your use of the Services or breach of this Agreement (collectively referred to as "Claims"). Banner reserves the right at its sole discretion and at its own expense, to assume the exclusive defense and control of any Claims. You agree to reasonably cooperate as requested by Banner in defense of any Claims.

## 6.6 FCC Part 15 and CAN ICES-3 (B)/NMB-3(B)

---

This device complies with part 15 of the FCC Rules and CAN ICES-3 (B)/NMB-3(B). Operation is subject to the following two conditions:

1. This device may not cause harmful interference, and
2. This device must accept any interference received, including interference that may cause undesired operation.

This equipment has been tested and found to comply with the limits for a Class B digital device, pursuant to part 15 of the FCC Rules and CAN ICES-3 (B)/NMB-3(B). These limits are designed to provide reasonable protection against harmful interference in a residential installation. This equipment generates, uses and can radiate radio frequency energy and, if not installed and used in accordance with the instructions, may cause harmful interference to radio communications. However, there is no guarantee that interference will not occur in a particular installation. If this equipment does cause harmful interference to radio or television reception, which can be determined by turning the equipment off and on, the user is encouraged to try to correct the interference by one or more of the following measures:

- Reorient or relocate the receiving antenna.
- Increase the separation between the equipment and receiver.
- Connect the equipment into an outlet on a circuit different from that to which the receiver is connected.
- Consult the manufacturer.