

SYLVANIA NEWS

JANUARY 1950

COPYRIGHT 1950
SYLVANIA ELECTRIC PRODUCTS INC.

EMPORIUM, PENNA.

BOB PENFIELD, EDITOR

VOL. 17, NO. 1



YOUR
SYLVANIA TUBE
CARTONS ARE
WORTH 2c
IN TRADE

Spotlight For '50 Will Be On TV

"Business in 1950 should be on a more constructive basis with less emphatic seasonal swings," Don G. Mitchell, president of Sylvania stated in his annual year-end review and forecast. "We of Sylvania Electric believe that the recession fear complex has largely been cast aside.

"With the exception of a relatively few lines, where demand may continue to crowd production, the buyer will be in the saddle and the market will be strongly competitive," he predicted.

Mr. Mitchell commented on specific markets as follows:

"Television will continue to show its spectacular growth in 1950 with industry estimates of an increase in the number of sets to be sold in the order of 50 per cent or around 3¾ million sets. Judging from the current demand for picture tubes, the market should be 90 per cent or better in 12½-inch and larger sets.

"In addition to requirements of set manufacturers, a certain proportion of television set users should be in the market this year for tube replacements, slowly at first but growing throughout the year. It has been estimated that 1950

sales will be about 5 million picture tubes. Sales by the industry in 1949 are estimated to reach nearly 3½ million tubes.

"Previous record year for radio receiving tubes was 1948 when nearly 205 million tubes were sold. As the result of the heavy demand by television set manufacturers and a revived radio set market, receiving tube sales for 1950 are expected to exceed 200 million tubes and may very easily set a new record. Tube sales in 1949 are estimated to be something over 190 million tubes.

"Other electronic tube sales are dependent in large measure upon requirements of the armed forces. Judging from the size of the Federal budget for defense, the industry should run at a comfortable, if not full capacity for the next year and a half.

"All in all, however, the outlook for 1950 is favorable and employment should show a great improvement in stability."



Don Mitchell

From Our Readers

Some of the most ardent readers of SYLVANIA NEWS are service dealers in foreign countries. Every month Sylvania mails copies of THE NEWS to dealers in more than 45 countries in every part of the world outside of the "Iron Curtain." These readers follow each word of THE NEWS with intense interest. Typical of these readers is M. Mamamorthy of the Oriental Trading Company, Madura, South India. We quote in part from a letter received from him recently:

"We thank you very much for your regular mailing us the esteemed SYLVANIA NEWS, which we await eagerly every month. Every issue of THE NEWS contains only such information as will be most instructive to servicemen technically or commercially.

"The article 'Who Said Radio is Dead' (September 1949) by H. H. Rainier was really very informative. Because, laying the public view of the Americans aside, we here have really been hitherto of the opinion that radio is actually dying out in the new world.

"The instructions given in 'Window Displays—Supersalesmen of Service' are all worth applying and practicing. For, only those points which we overlook so often are brought to light here. It has really been an article written exclusively for every business concern in our country.

"Thanking you for all your services to electronic service industry."

EDITOR'S NOTE: The Staff of SYLVANIA NEWS is grateful for the comments from our Indian reader. We hope that we are in some measure performing a worthwhile service for all members of the radio industry in every corner of the world.

ON THE COVER

Inspection and settling of television picture tubes at Sylvania's Ottawa, Ohio plant. Conveyor system carries glass bulbs to different points in the factory for processing. Tubes in picture are 16 inch all-glass tubes. Sylvania's complete line of picture tubes include, 7, 10, 12, 16, and 19 inch tubes. Both all-glass and the glass-metal tubes are made by Sylvania.

Modern, Quality Generator At Big Saving

One of the few testing devices designed to do an overall job of alignment and as a signal source for testing FM and AM receivers is the Signal Generator.

This instrument is one which saves the technician hours of service time as well as contributing to the overall efficiency of service work.

The Sylvania Signal Generator Type 216 is an excellent example of a top quality signal generator for radio service work.

This testing device has been designed to accurately align rf and if sections of all FM and AM receivers, adjust all types of FM detectors, and make overall checks.

The high level output of this instrument and the accurate calibration make the Sylvania Signal Generator Type

216 a valuable instrument for other service and laboratory uses where a high quality rf signal source is required.

Cabinet styling of the Sylvania Signal Generator is in keeping with modern service shop environment.

See the Sylvania Signal Generator at

your Sylvania Distributor. It is now offered to servicemen at a new low price of \$139.50, a reduction of more than 25% over the previous price.

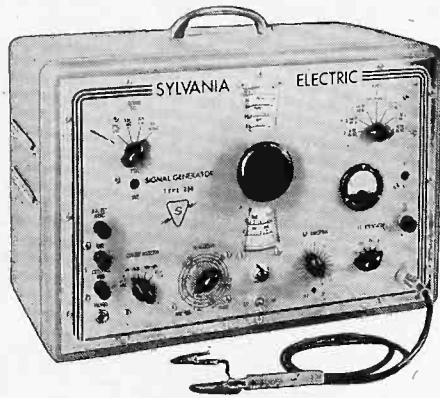

Signal Generator Type 216

SYLVANIA NEWS

Merchandising
Section

JANUARY 1950—VOL. 17, NO. 1

COPYRIGHT 1950
SYLVANIA ELECTRIC PRODUCTS, INC.

**YOUR SYLVANIA TUBE
CARTONS ARE WORTH 2¢
IN TRADE!**

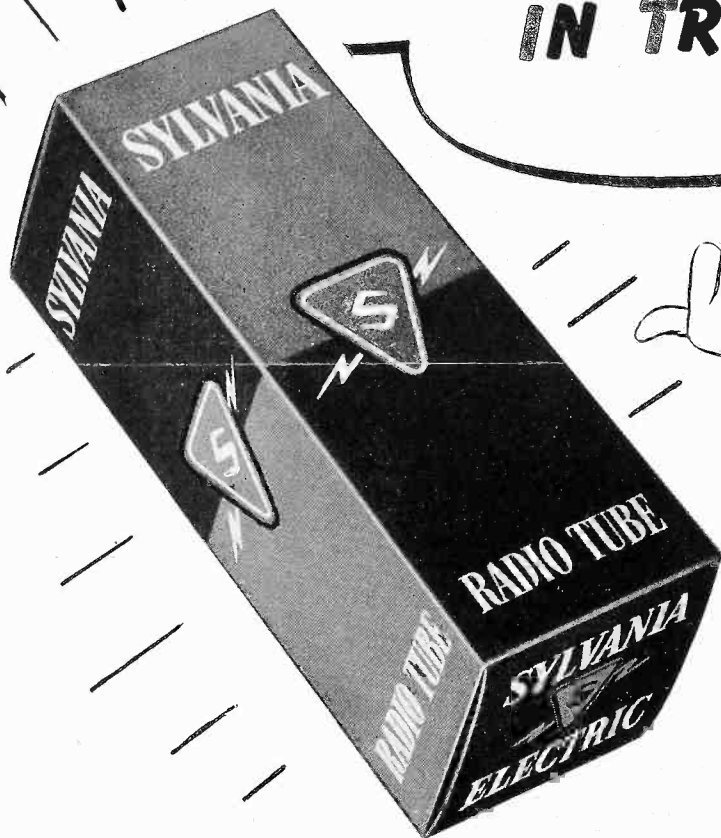

During February, March and April, empty Sylvania receiving tube cartons will be worth two cents in trade when applied against the purchase of Sylvania advertising material, tubes, test equipment, and other Sylvania products, according to H. H. Rainier, manager of distributor tube sales for Sylvania.

During these three months, Sylvania Distributors all over the country will accept empty Sylvania tube cartons and issue dealers a credit of two cents on each carton. This credit can then be applied

against the purchase of any Sylvania products he sells, or against the purchase of all material from the Sylvania "Pennies" catalogue.

When applied against the purchase of advertising material, these cartons will help to increase service business and move more tubes. When applied against the purchase of Sylvania test equipment, the cartons will help speed up service work—allow you to handle more service jobs.

Here are some of the many Sylvania products which empty Sylvania tube cartons will help you buy . . . Sylvania Coordinated

Advertising Campaigns, signs, business forms and stationery, technical helps. Sylvania Receiving Tubes, Sylvania Television Picture Tubes, Sylvania Transmitting Tubes, Sylvania Test Equipment including the famous Polymeter, Tube Tester, Counter or Portable, Sylvania Signal Generator, the big Sylvania Oscilloscope, and any other Sylvania products sold by the distributors.

Make sure to cash in on this special offer during February, March and April. Start saving Sylvania Receiving Tube Cartons now. See your Sylvania Distributor for more complete details.

Here's a Free Book For Sylvania Tube Dealers

Here's a special bonus for Sylvania Tube Dealers during February and March. With the purchase of 25 Sylvania Receiving Tubes from Sylvania Distributors during both months, dealers will receive, free of charge, a copy of Sylvania's new book, "Television Receiver Tube Complement Book."

This book, to be published February 1, lists the complete tube complements of 620 different television receiver models made by 85 TV set manufacturers. It lists 136 receiving tube types used in these receivers. The book also shows 48 different TV picture tube types and tells the receiver in which each is used.

You can save time on every home service call by having a copy of this book in your library. At a glance, you can tell what tubes you will need for each call. The book also helps dealers to buy and stock the correct types of tubes and keep stocks fast moving. Thus it helps reduce inventory of slow moving types which tie-up money.

With this special offer for February and March, Sylvania dealers will be able to cash in on a double bonus. The 25 empty cartons from the tubes purchased to get the book can be used for credit on other Sylvania merchandise. See the story on Page M-1 for details on the "two-cent-trade-in deal." Make sure you get your copy of the Television Receiving Tube Complement Book from your Sylvania Distributor during February and March only.

CONTAINS COMPLETE TUBE COMPLEMENT OF MORE THAN SIX HUNDRED CURRENT MODEL TELEVISION RECEIVERS

TELEVISION RECEIVER TUBE COMPLEMENT BOOK



SYLVANIA ELECTRIC PRODUCTS, INC.
EMPORIUM, PA.

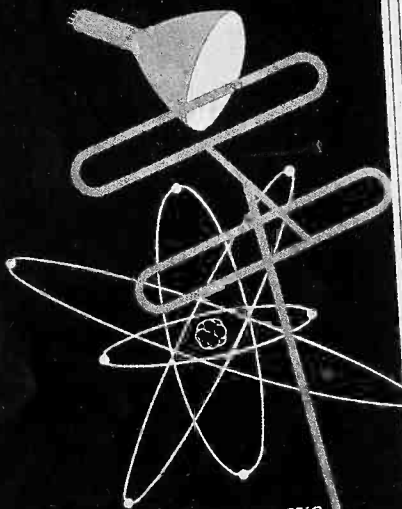

Building Service Business Every Minute . . .

Specially prepared ads like those pictured at the left are working continuously to boost your service business. Each month 15,000,000 people see these ads in the magazines shown here.

Readers are attracted by these crisp, cartoon type ads. The copy in these ads tell the reader to stop at the Sylvania Sign for dependable radio and television service for expert work at the fairest prices.

Hundreds of the readers of these magazines are potential customers. You can make sure these readers come to your service shop for service when their set needs repair. To attract customers in your own locality, use the Sylvania Co-ordinated Advertising Campaign. It is a complete promotion designed especially for radio service dealers. See your Sylvania Distributor or write for full information to the Advertising Department, Sylvania Electric, Emporium, Pa.



SYLVANIA NEWS

TECHNICAL
SECTION

JANUARY 1950

COPYRIGHT 1950
SYLVANIA ELECTRIC PRODUCTS INC.

VOL. 17, NO. 1

THE INFORMATION IN SYLVANIA NEWS IS FURNISHED WITHOUT ASSUMING ANY OBLIGATION

TECHNICAL EDITOR A. V. BALDWIN

TELEVISION SERVICING BY PICTURE ANALYSIS - I

By C. Masucci* and W. B. Whalley†

Photographs by L. W. Ankerson

This is the fifteenth of a series of articles on Television by Sylvania Engineers.

A great variety of defects in a television receiver can very often be quickly located by an analysis of the picture on the face of the picture tube. To make a correct analysis,

*Mr. Masucci is a member of the research staff of Sylvania's Physics Laboratory in Bayside, N. Y. He joined Sylvania in 1948 after having been employed by Western Electric Company as an electrical engineer. During the war he served in the Navy as an electronic specialist. Mr. Masucci received the degree of B. E. E. at the College of the City of New York in 1944.

†Mr. Whalley is also a member of the research staff at Sylvania's Physics Laboratory, specializing in television. He joined Sylvania in 1948 after extensive experience in television and radar at RCA and in Canadian laboratories. He received the degree of B. A. Sc. with honors in 1932 and M. A. Sc. in 1935 at the University of Toronto.

it is highly desirable that the serviceman have a good understanding of the contribution of each portion of receiver circuit to the complete picture. The reader is referred to previous articles of this television series in SYLVANIA NEWS and to the list of suitable books suggested for study at the end of this article.

The first basis of this picture observation method for locating defects is that the television signal is actually made up of two separate and distinct signals, one for the picture and one for the sound. The picture signal is further broken down into that portion which actually contains the information for the picture itself, and a second portion containing the synchronizing and blanking pulses used to present the picture information in an orderly manner. These various portions of the complete signal are separated

and passed through their respective circuits.

It then becomes a relatively simple matter, once the basic principles are understood, to analyze the picture and determine just which portion of the circuit is out of order. As an example, we may take the condition that the picture height is not as great as it should be and that the bottom portion of the picture is very crowded (that is, objects in the lower part of the picture are much shorter vertically than they should be), yet other conditions are normal. Note that the picture contains the usual variations in light intensity; it is synchronized both vertically and horizontally; it is of the proper width; and it is interlaced properly. Therefore, we should look for trouble in the vertical deflection circuits. First, check the vertical size and linearity controls. Next, check the

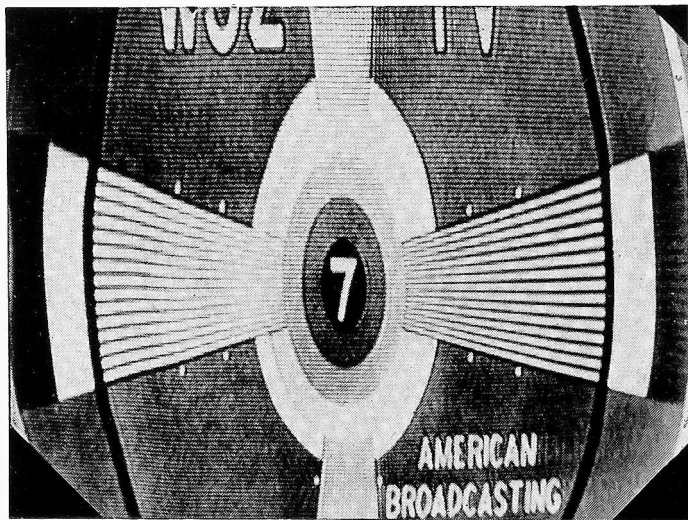

CONDITION—Greatly expanded, non-linear picture in vertical direction. CAUSE—(A) Shorted bypass condenser in the cathode circuit of vertical scanning tube, or (B) Serious misadjustment of the vertical height and linearity controls.

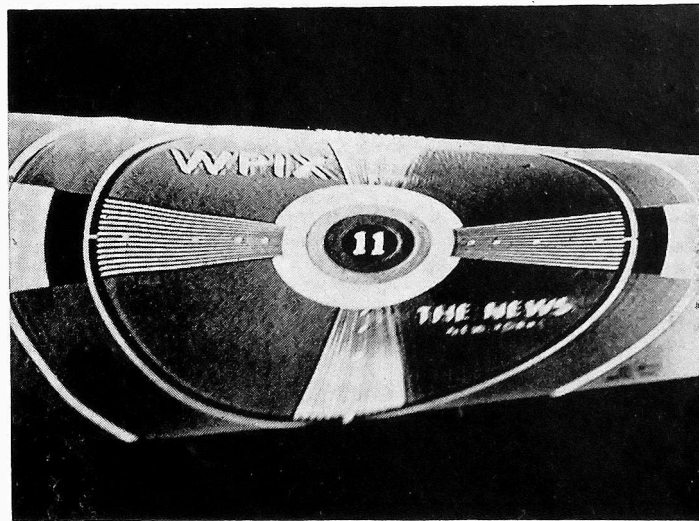

CONDITION—Vertically keystone picture, greater effect at top. CAUSE—(A) Vertical deflection coil shorted from center to high side. If shorted from center to bottom side, greater effect would be at bottom of picture.

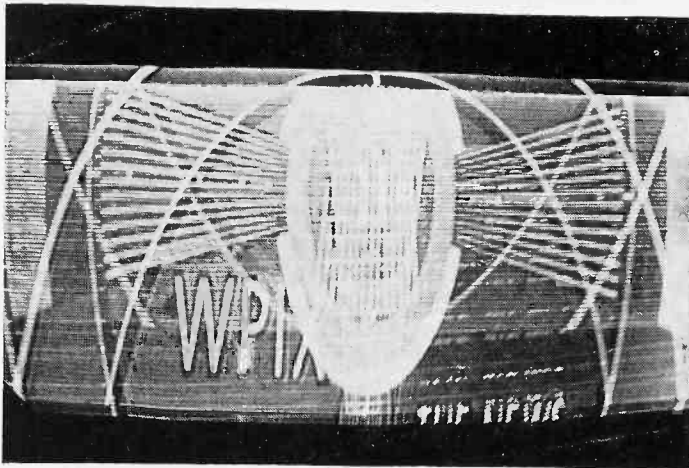

CONDITION—Picture folded over vertically. **CAUSE**—(A) Grid to cathode or grid to ground leakage in vertical blocking oscillator tube, or (B) A high series resistance has developed in the plate side of vertical blocking oscillator transformer.

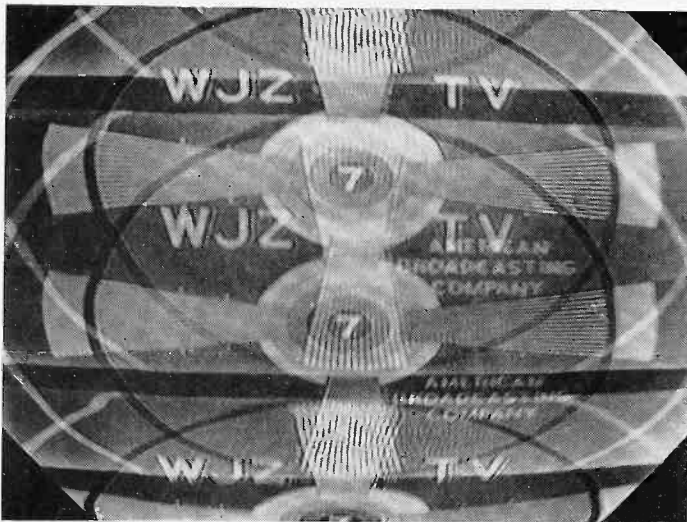

CONDITION—Picture not synchronized vertically. **CAUSE**—(A) Misadjustment of vertical hold control, (B) High series resistance has developed in grid side of vertical blocking oscillator transformer, or (C) Open or shorted condenser in vertical sync filter network.

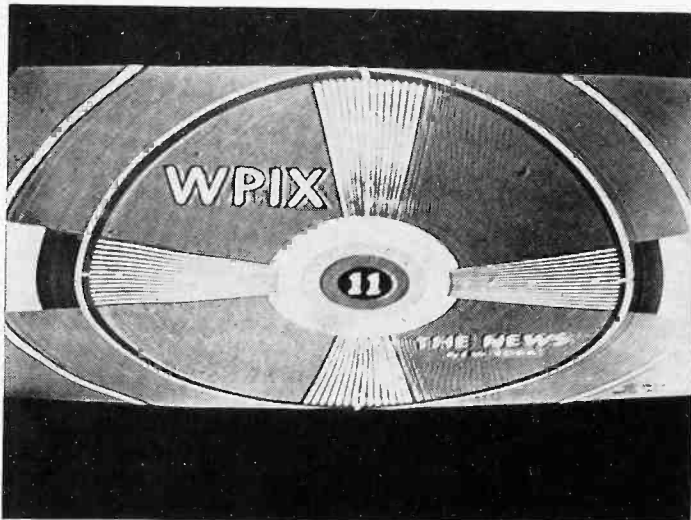

CONDITION—Vertically small and non-linear picture. **CAUSE**—(A) Misadjustment of the vertical height and linearity controls, or (B) The vertical deflection transformer has developed a high series resistance on the plate side.

vertical output transformer for resistances of the windings (the correct resistance values are obtainable from the service notes of the particular receiver under consideration.) The vertical output tube may have developed low emission. The point is that the defective part is in this section of the receiver and the work necessary to locate it may be materially reduced by first localizing the source of the trouble as closely as possible.

A study of the accompanying photographs should prove to be of value in reducing the time required to service a television receiver, even though the discussion is far from being complete, because it describes the method to be used in locating a defective component. The use of this method will help considerably with the general run of service problems and will point the way to reduced costs and therefore, increased profits for the service industry. The second part of this article illustrating horizontal deflection troubles will be presented in an early issue of Sylvania News.

CONDITION—No light on picture tube and no sound. **CAUSE**—(A) Receiver not connected to power line. (B) Defective fuse. (C) Defective low-voltage power supply. (D) Shorted condenser on either side of linearity coil. Effectively a short on the low voltage supply through the damping tube.

CONDITION—No raster on picture tube, but normal sound. **CAUSE**—(A) Shorted condenser in output of high-voltage power supply. (B) Horizontal output transformer either open or shorted. (C) Shorted screen bypass condenser in circuit of horizontal output tube. (D) One or more horizontal deflection circuit tubes defective, including the high-voltage rectifier. (E) Shorted or open horizontal deflection yoke. (F) Open brightness control potentiometer. (G) Shorted condenser on No. 2 grid of picture tube. (H) Ion trap completely out of adjustment. (I) Open filament in picture tube. **NOTE**—In receivers having an r-f high-voltage power supply, also check for the following: (A) Defective oscillator tube (B) Defective oscillator coil. In receivers having a high-voltage power supply which are not dependent upon the horizontal deflection circuits, the absence of the raster may not be due to any defect in the deflection circuits.



CONDITION—Poor vertical linearity. **CAUSE**—(A) Misadjustment of the vertical linearity control, or (B) The vertical deflection tube should be checked for defective operation, and if defective, it should be replaced with a new tube.

BOOKS FOR FURTHER READING

The Video Handbook. Boland & Boyce Inc., Publishers, Montclair 3, N. J.

Television for Radiomen, 1950, by Edward M. Noll. The Macmillan Co., New York 11, N. Y.

Television Servicing for Radiomen, 1949, by H. P. Manly. Frederick J. Drake Co., Wilmette, Ill.

Practical Television Servicing, 1949, by J. R. Johnson and J. H. Newitt. Murray Hill Books, Inc., New York, New York

Basic Television—Principles and Servicing, 1949, by Bernard L. Grob. McGraw-Hill Book Co, New York 18, New York

Television Simplified, by Milton Kiver. D. VanNostrand Co., New York, New York

Television—How It Works, 1948, by John F. Rider. John F. Rider, Publisher, New York, New York

PhotoFact Television Course. Howard W. Sams & Co., Indianapolis 1, Indiana

CONDITION—Raster on screen, but no picture. **CAUSE**—Defective video amplifier tube. In this case synchronization of the raster depends on whether the sync voltage separation is located before or after the defective tube.

CONDITION—A horizontal line only appears on the picture tube (no vertical sweep.) **CAUSE**—(A) Defective vertical output transformer, shorted or open on either plate side or yoke side. (B) Defective vertical blocking oscillator transformer, grid side or plate side either open or shorted. (C) Defective vertical scanning tube or vertical oscillator tube. (D) Vertical deflection winding of yoke either open or shorted

CONDITION—Picture floating across the screen horizontally. **CAUSE**—(A) Loss of horizontal sync voltage, probably due to open coupling condenser. (B) Defective reactance tube in "synchrolock" circuit.

CONDITION—A series of dark vertical bars at random locations across the screen. Do not necessarily appear on every channel. **CAUSE**—Internal oscillations (Barkhausen-Kurz) of the horizontal scanning tube being picked up by the receiver r-f sections.

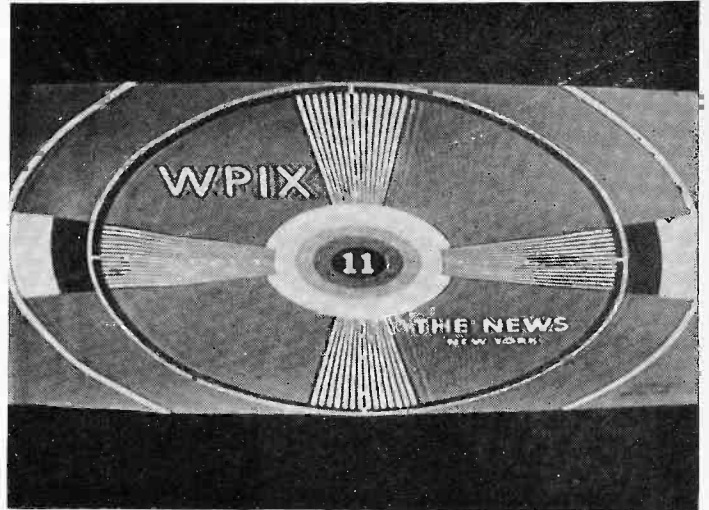

CONDITION—Vertically small, but linear picture. **CAUSE**—Peaking resistor in vertical oscillator increased considerably in resistance.

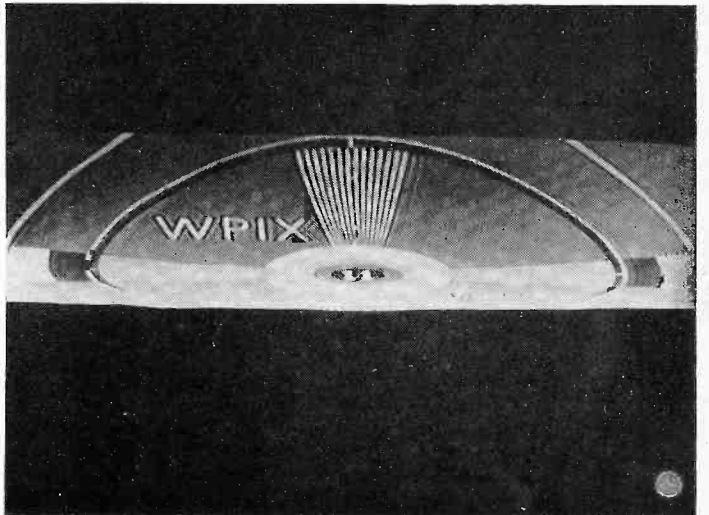

CONDITION—Vertically small and extremely non-linear picture. **CAUSE**—Cathode of vertical scanning tube is unbypassed.

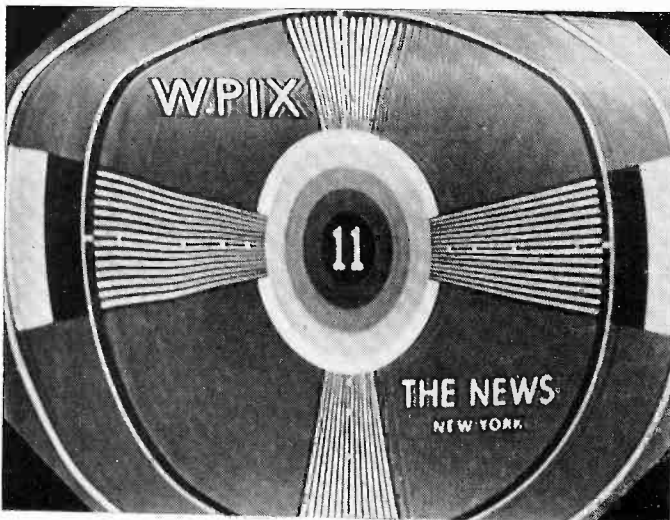

CONDITION—Vertically non-linear picture (flat on top.) **CAUSE**—Peaking resistor in vertical oscillator shorted.

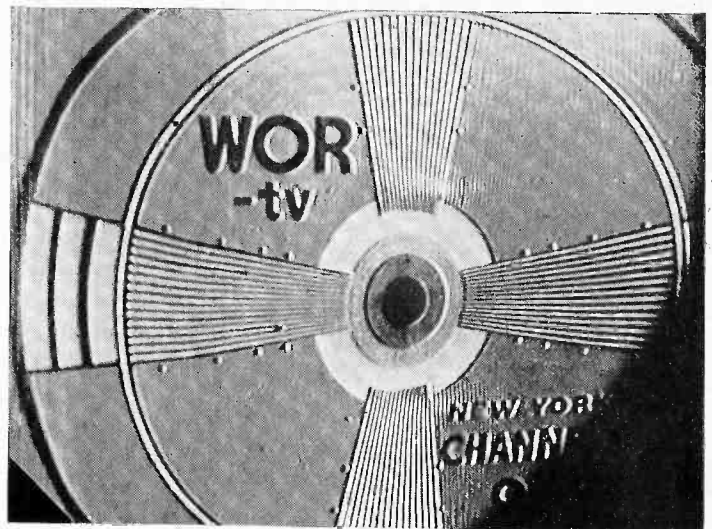

CONDITION—A shadow or dark area on one side of picture. **CAUSE**—The ion trap is out of adjustment. Should be corrected by relocating the small magnet on the neck of the tube until the picture has greatest brilliance.

Modernization of Sylvania Type 139-140 Checkers For Type 1X2

We suggest that all owners of Sylvania Model 139 - 140 tube checkers bring their instruments up-to-date by making the simple change in connections described below.

Before making this change it is necessary to have installed the 9 pin modernization kit (obtainable from Sylvania distributors and Service Stations as Type 218). In this installation the wire from the top cap connector now goes to the #8 position on the deck of the B switch nearest the panel. The change is to move the top cap wire only from this deck to the #8 position on the deck farthest from the panel.

Now test type 1x2 as shown below:

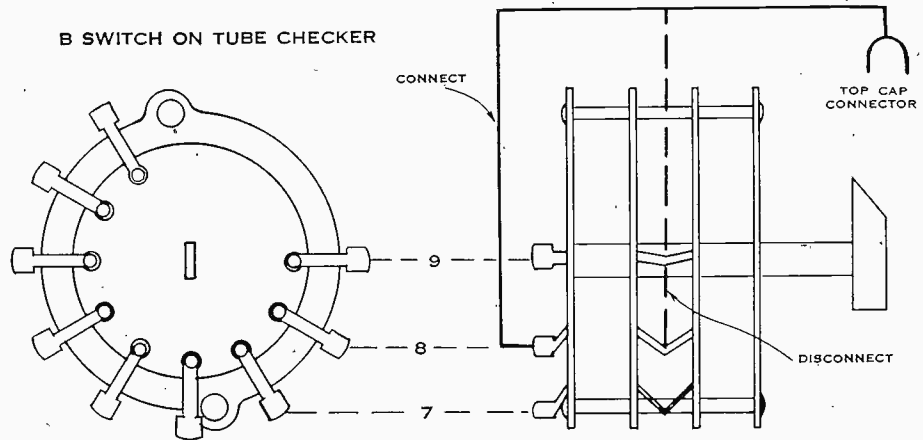

SIMPLE CIRCUIT CHANGE TO MODERNIZE SYLVANIA TYPE 139 - 140 TUBE CHECKERS

NEW AND REVISED TUBE CHECKER SETTINGS

TYPE	A	B	C	D	E	F	G	TEST	TYPE	A	B	C	D	E	F	G	TEST
OY4	.75	0	7	0	3	—	19	Y	7AK7	6.3	0	—	0	1	036	45	Y
1L6	1.4	3	3	5	1	056	33	V	12AX7	12.6	0	5	0	1	3	16	V
	"	"	3	5	0	058	37	V		"	"	"	0	3	7	16	V
1R5	1.4	2	45	4	1	016	60	T	12BA7	12.6	0	—	0	4	027	49	T
	"	"	"	"	0	8	65	U		"	"	"	0	1	3	34	U
1W4	1.4	2	4	4	1	016	50	U	12BK6	12.6	0	—	0	3	3	17	V
*1X2	1.4	8	12345	0	8	—	69	T		"	"	"	0	4	—	55	T
2E22	6.3	0	—	0	8	023	26	Y	12BU6	12.6	0	—	0	3	3	67	U
3D24	6.3	1	1478	1	8	56	47	X		"	"	"	0	4	—	55	T
6AB4	6.3	0	—	0	2	6	38	U		"	"	"	0	5	—	55	T
6AB5/6N5	6.3	0	—	0	1	3	79	W	25BQ6GT	25.0	0	—	0	8	034	22	Y
	"	"	"	"	3	—	—	W	25Z6	25.0	0	—	0	1	—	19	Z
6BK6	6.3	0	—	0	3	3	15	V		"	"	"	0	3	—	19	Z
	"	"	"	0	4	—	55	T	26A6	25.0	0	—	0	4	36	47	U
	"	"	"	0	5	—	55	T	815	12.6	4	47	1	8	038	19	X
6BT6	6.3	0	—	0	3	3	15	V		12.6	4	47	1	8	13	19	X
	"	"	"	0	4	—	50	T		12.6	4	47	1	8	13	19	X
	"	"	"	0	5	—	50	T	5722	5.0	0	46	0	2	—	70	Y
6BU6	6.3	0	—	0	3	3	40	W		"	0	34	0	5	—	70	Y
	"	"	"	"	5	—	52	T									
	"	"	"	"	4	—	52	T									
7AJ7	6.3	0	—	0	1	036	48	U									

*Modernization change described above is necessary before using these settings.

COMING SYLVANIA SERVICE MEETINGS

Now that the Christmas rush is over servicemen in the Wisconsin and Indiana area will be glad to hear that service meetings are being resumed. The speaker at all the meetings listed below will be Clarence L. Simpson and the subject is

"Television and the Serviceman."

The distributors sponsoring these meetings generally notify the dealers and servicemen on their mailing list but you might be missed. Please notify your

Sylvania distributor that you wish to attend so that he will have room for you. Sylvania News is printed too far ahead for us to give a complete list of meetings but the list below will help some of you.

DATE	SPONSORED BY	LOCATION
2/6	Satterfield Radio Supply 326 West Gorham Street Madison, Wisconsin	Turner Hall 21 South Butler St. Madison, Wis.
2/7	Northwest Radio & Elec. Supply Co. 52 South Twelfth Street Minneapolis, Minnesota	Curtis Hotel East Ballroom Minneapolis, Minn.
2/8	G. M. Popkey Main at Ninth Street Marinette, Wisconsin	Eagles Club Room Third & Jackson Sts. Highway 51 Wausau, Wisconsin
2/9	Appleton Radio Supply 1217 N. Richmond Street Appleton, Wisconsin	Koehne's Hall 501 N. Richmond St. Appleton, Wis.

DATE	SPONSORED BY	LOCATION
2/10	Radio Parts Co., Inc. 538 W. State Street Milwaukee 3, Wisconsin	Engelman Hall Milwaukee Auditorium Milwaukee, Wis.
2/13	Commercial Sound & Radio Co. 528 East Colfax Avenue South Bend 17, Indiana	Commercial Sound & Radio Co. 528 East Colfax Ave. South Bend 17, Ind.
2/14	Radio Distributing Co. 1013 N. Capital Avenue Indianapolis 4, Indiana	Warren Hotel 123 S. Illinois Street Indianapolis, Ind.
2/15	P. I. Burks & Company 911 West Broadway Louisville, Kentucky	WKLO Broadcasting Station Henry Clay Hotel Louisville, Kentucky
2/17	Archer & Evinger 1348 Wabash Avenue Terre Haute, Indiana	Terre Haute House Wabash Room Terre Haute, Ind.

How To Get Efficiency At A Service Bench

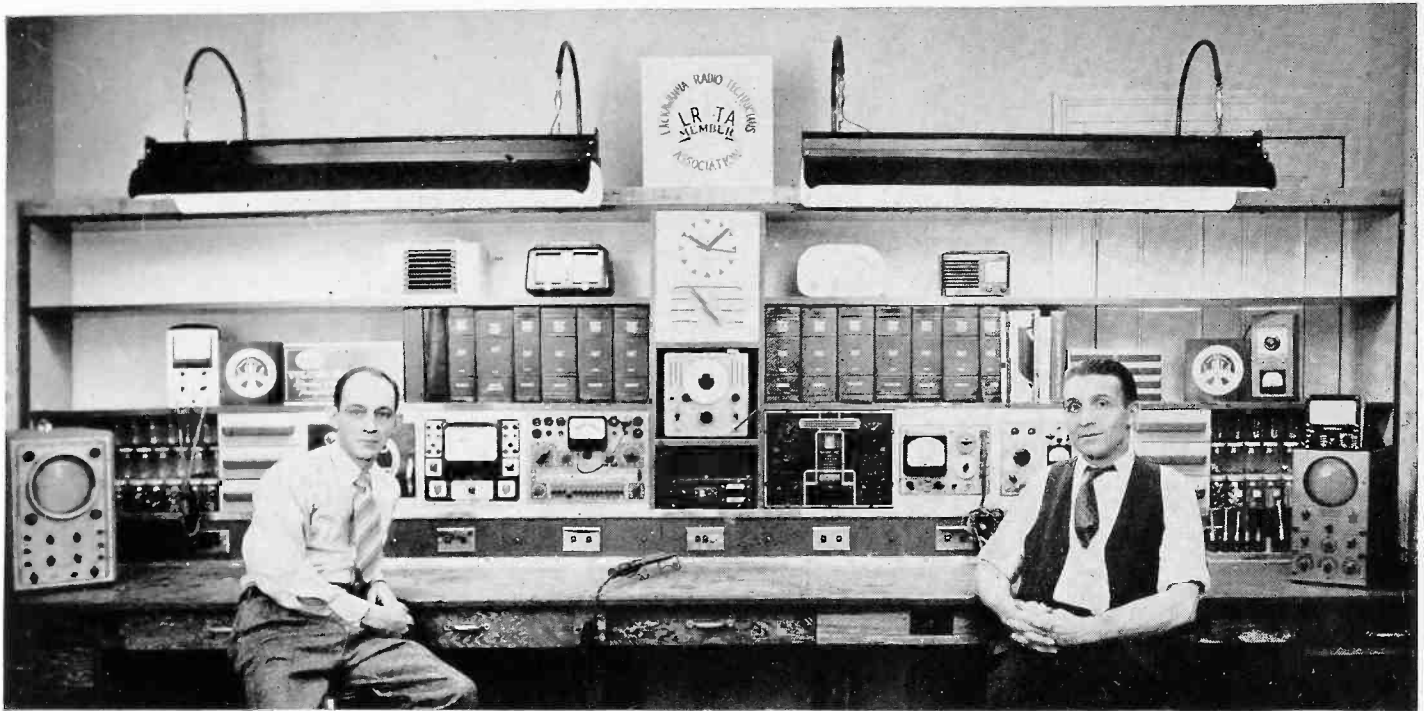

Leland Jenkins of Honesdale, Pa. is another service dealer who counts on a neat service bench to help run his shop efficiently. Since neatness and more business inevitably go together, Jenkins insists that his

working area accommodate all the necessary tools close at hand. Above is Jenkins and his service man, Charles Zaverl. Note Sylvania seven inch oscilloscope, left, and Sylvania tube tester mounted in

panel, center. These are a few of the test instruments upon which Jenkins depends to help speed work on sets. Plenty of light for working is furnished by the two large fluorescent fixtures mounted above the bench.



Regular Mailing of Sylvania Campaign Builds Service Business

More and more, radio and television service dealers all over the country are using the Sylvania Coordinated Advertising Campaign to get new business and keep their old business. No exception is James Cecil of San Diego, California. Inset, Frank Zurek, Radio Parts Company, Sylvania Distributor in San Diego delivers campaign to Cecil.

Cecil's Television and Radio Service keep their name before customers by mailing postal cards from Sylvania's coordinated advertising campaign to customers and prospects every month. At the left above, James Cecil hands Mrs. Cecil cards for addressing. Cecil uses inexpensive address machine to address cards. This helps him to cover more prospects and get more business.

Business Builders For Sylvania Tube Cartons

Sylvania Tubes are always sure to give the best service and for helping to increase service business, Sylvania advertising and sales promotion material is tops. Illustrated here are a few of the store identification, business, sales promotion and technical aids available to servicemen. Any of these items may be purchased through Sylvania Distributors. During February, March and April empty Sylvania Receiving Tube cartons are worth 2c in credit when returned to your distributor. (See Page M-1 for details.)

The credit may be applied against the purchase of any of the items illustrated here plus the many other sales promotion aids listed in the Sylvania "Pennies" Folder.



FLOURESCENT ELECTRIC SIGN.—Big, brilliantly illuminated flourescent sign. Costs less than a penny a day to run. For hanging or standing in window. Identifies you as a service dealer. Price \$7.50.

Business Forms

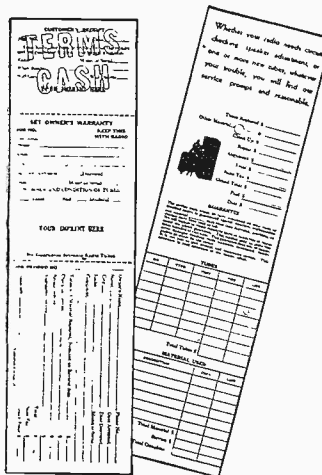

JOB RECORD CARDS. — Customer's receipt for cash payment. A complete record of each service job. Imprinted. 100—\$1.00; 250—\$1.75; 500—\$3.00.

Technical Literature

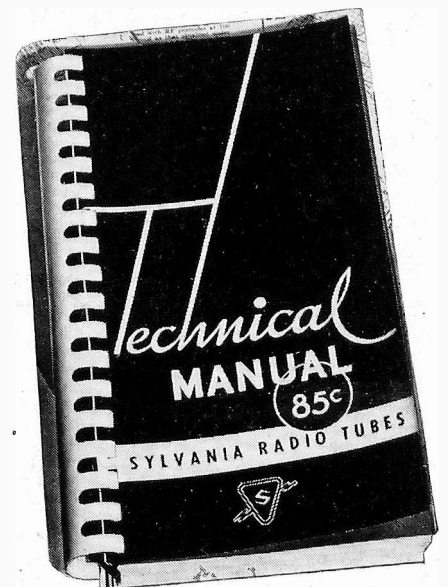

SYLVANIA TECHNICAL MANUAL.—Lists complete data on more than 637 tube types. Price 85c.

Service Helps



SERVICE KIT.—Constructed of 3/8" plywood. Covered with handsome plastic fabric. Ideal for outside service calls. Price \$9.95.

Say, Mr. Radio Service Dealer

Did you know your SYLVANIA tube cartons are worth 2¢ a piece?

Better ask your authorized Sylvania Distributor about it—TODAY!

Sales Aids

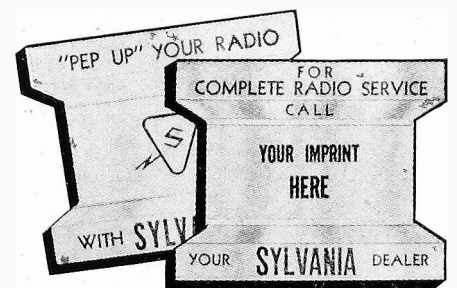

ANTENNA SPOOL.—Handy reminder to customers. Convenient for winding antenna when set is being repaired. Imprinted. 100 - \$1.25; 250 - \$2.50; 500 - \$4.00.



Ray Immel, Thompson Radio, left, and George Boller, right, Electronic Supply Co., Columbus, Ohio talk over Sylvania Test Equipment during intermission at Columbus Service Meeting.

Sylvania Television Meetings to Continue This Year

Among the most popular services provided by Sylvania Distributors during the past year, were the service meetings held in all parts of the country. Although not every city enjoyed the opportunity of receiving new television information from Sylvania lecturers Clarence Simpson and Ralph Shields, the boys covered a lot of ground and talked with a large number of service dealers.

In all, 91 Sylvania Service Meetings were held in 89 cities in 32 states plus Canada and the District of Columbia. Nearly 11,000 service dealers attended the meetings. To bring these meetings to dealers, Shields and Simpson traveled more than 60,000 miles during the year.

These meetings, long a popular feature with servicemen everywhere, will be continued during 1949. Tentative schedules have been arranged but complete information will be announced by Sylvania Distributors in the cities where the talks will be given. All dealers interested in receiving latest information and helpful hints on radio and television servicing will want to make these meetings a must on their calendars.



Large crowd of dealers at Dayton, Ohio look over their shoulders for Sylvania News photographer at recent service meeting. Meeting was sponsored by Standard Radio, Sylvania distributor in Dayton.

Unique Promotion For TV Meetings

Ebinger Radio & Supply Co., Sylvania Distributor, in St. Louis, in cooperation with KSD-TV is sponsoring a test pattern period as a public service to the television servicemen in the area. Pattern used is the standard clock pattern with the firm name and address revolving on the sweep second hand. Copy was changed three days before the Sylvania Television Service Meeting sponsored by the local Sylvania Distributors at the Claridge Hotel recently, to advertise the meeting. More than 350 servicemen attended this meeting, filling the Marine Room of the Claridge far beyond its capacity. The meeting itself was a high tribute to the earnestness of the servicemen and the ability of the speaker, Clarence L. Simpson, that despite a late start and an extremely hot night, not a single serviceman left before the meeting was over.

Shown on the left is a sample of the test pattern.

H. E. Ruble chides Bruce McEvoy, (with the grin), Sylvania District Manager during Dayton Meeting. Interested audience is composed of Standard Radio Staff along with Sylvania John Vail and Clarence Simpson.

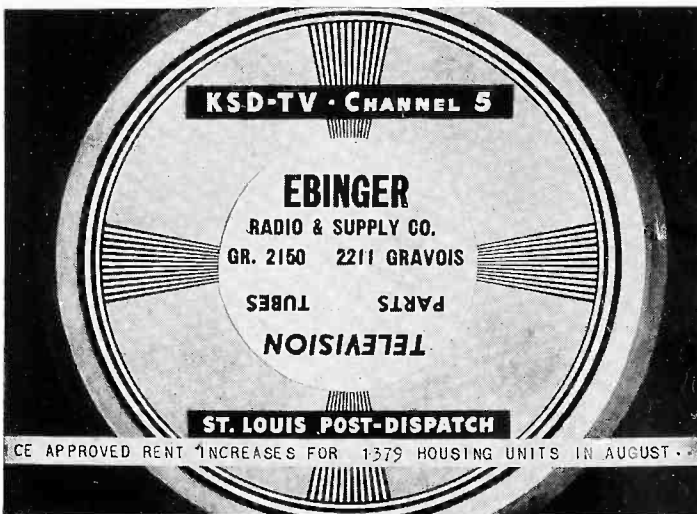

Group of dealers listen attentively as Clarence Simpson tells about television servicing at Canton, Ohio meeting. Meeting was sponsored by Sylvania Distributors, Sommers Electric and Armstrong Radio.



Quality Control Aids Trouble-Free TV

Quality control engineering, which has been highly developed during the past ten years, is one of the vital services of manufacturers that has made relatively trouble-free television possible, according to Jerome R. Steen, director of quality control for Sylvania.

He said that present television sets are far more complicated than broadcast receivers and that precise values of components must be used or sections of the receiver cannot be coordinated. "Because of this engineering fact," Steen continued, "television set manufacturers have taken great pains to set up radio technicians in the service field with far greater knowledge and skill than was formerly required for radio. They did this because television sets require far more critical adjustments and exacting performance of each part and of the circuit in which it operates.

"Proof of the important part played by quality control not only in the manufacture of sets but also in each component part," he con-

tinued, "has been borne out by experience since the war. As radio and television manufacturers have applied basic quality control methods to postwar products, they have been able to build far more reliability and dependability into television sets than was originally anticipated."

Recognition of these facts by television manufacturers, according to Steen, has tended also to make better sets requiring less service in the home available at lower cost. This public benefit, he explained, is due to the effect of quality control on manufacturing costs by reducing scrap, establishing product predictability and eliminating many individual inspections previously assumed to be necessary to assure product quality.

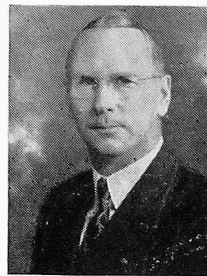

Jerry Steen

Facts & Figures...

TV Set Production

Production of television sets as well as other types of receivers reached a new high for the year in November. Total TV set production amounted to 414,223 sets and brought total production for eleven months of 1949 to 2,121,836 sets. FM-AM and FM only sets numbered 122,603. This was the second highest number of sets of this type manufactured in any one month this year. AM only sets totaled 787,533 making the total of all sets manufactured by RMA member-companies during November to 1,324,359.

Manufacturers' Orders Equal Sales

New orders received by manufacturers during recent months have about equaled sales, according to the Department of Commerce. This is in contrast to order behavior during the period from the beginning of 1947 to the summer of 1949 when shipments or sales consistently outran new business and the huge backlogs built up after the end of the war were gradually reduced to more normal proportions.

These developments are analyzed in the December Issue of the Survey of Current Business. "Essentially, the trend of business has maintained an even keel this fall, following a recovery from the summer low, with rising construction activity and the virtual cessation in inventory liquidation offsetting declines in business investment in plant and equipment and prices of agricultural products," the publication said.

SYLVANIA NEWS

SYLVANIA ELECTRIC PRODUCTS INC.
P. O. BOX 431
EMPORIUM, PENNA.

Sec. 3486, P. L. & R.
U. S. POSTAGE
PAID
Permit No. 1
Emporium, Pa. *

For:

J. A. Renville
163 Main St.
Luzerne, Pa.

A.

POSTMASTER: IF UNDELIVERABLE FOR ANY REASON, NOTIFY SENDER, STATING REASON, ON FORM 3547, POSTAGE FOR WHICH IS GUARANTEED.

Vol. 17, No. 1

JANUARY, 1950

PUBLISHED BY
SYLVANIA ELECTRIC PRODUCTS INC.

MANUFACTURERS OF SYLVANIA RADIO TUBES, CATHODE RAY TUBES, ELECTRONIC DEVICES, FLUORESCENT LAMPS, FIXTURES, WIRING DEVICES, ELECTRIC LIGHT BULBS, PHOTOLAMPS, RADIO AND TELEVISION RECEIVERS

In This Issue

NEWS

SPOTLIGHT FOR '50 ON TV

MERCHANDISING

SYLVANIA TUBE CARTONS
WORTH 2c IN TRADE

TECHNICAL

TELEVISION SERVICING
BY PICTURE ANALYSIS—1

Meet the SYLVANIA TYPE 220 TUBE TESTER

By James H. Canning
Senior Design Engineer

- *Exclusive new leakage and shorts test reads on meter.
- *Composite emission and mutual conductance test made under dynamic conditions.
- *Easy-to-operate gas test finds gassy tubes quickly.
- *Choice of three a-c signal voltages gives tubes correct test.
- *Sockets for all commonly used tubes. Blank socket for future developments.
- *Switch positions numbered to correspond to tube pins.
- *Heavy duty precision components mean long dependable service.
- *Spring loaded test switch applies test voltages only when needed.



Sylvania is announcing the availability of the types 219 and 220 Tube Checkers. The Type 220 shown here is a rugged portable model and the Type 219 is the corresponding counter model.

Sylvania design engineers have succeeded in overcoming the weak features in most tube checkers and

now offer an instrument with a time - proven fundamental circuit with all the refinements that give accuracy, reliability and convenience in using. For example, a common trouble in all neon lamp types of short test indicators is caused by the variation in firing voltage of the neon lamps. Indi-

vidual lamps may vary from 55 to 85 volts initially and then change with use. In these Sylvania instruments this difficulty is overcome completely by switching the meter to an ohmmeter circuit as shown in Fig. 1. All resistances which indicate an excessively "leaky" or shorted condition read "Bad," and

high values of resistance read "Good" on the meter.

If you have a "pet peeve" about tube checkers in general, look over the features of the new Sylvania instruments described in the following paragraphs and see how Sylvania engineers have overcome it for you.

What a Tube Tester Must Do

There are two principal reasons for a serviceman buying a tube tester. He buys it so he can discover defective tubes among those

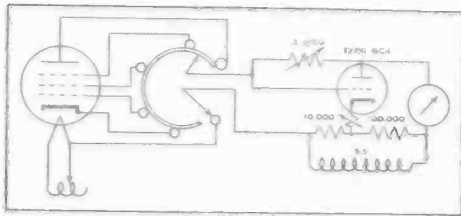

Fig. 1—Simplified shorts and leakage test circuit. Space current effects are eliminated by positive cathode potential during testing.

customers bring him to test, or in receivers brought in for him to repair, and so increases his tube sales; or he buys it primarily to help solve difficult repair problems by accurately picking out tubes which are not serviceable, and are causing trouble in the set. Recently, many tube testers have also been bought for the purpose of preventive maintenance—that is, for use in making regular checks on tubes so that they can be replaced before they cause actual failure of equipment. This enables him to profit by replacing weak tubes customer's ears might not detect until a much later date.

Major Tube Characteristics on Which Tube Replacement Depends:

Emission

Poor emission results from faulty cathodes, long use, excessive plate current, or may be caused by low heater voltage. It shows up generally as decreased performance, particularly in oscillators, rectifiers, and power output tubes. This characteristic is of foremost importance, as a tube is primarily an electron emitting device, and if insufficient electrons are emitted from the cathode, it cannot work

under all the conditions it is expected to. Emission is measured under conditions which draw practically all available electrons from the cathode.

Mutual Conductance

Mutual Conductance, also often correctly called Transconductance, is important because it is a measure of the effectiveness of the tube as an amplifier or control device. The Sylvania Composite Emission-Transconductance test applies predetermined voltages to all elements, and applies an actual AC signal to the control grid, thus introducing a dynamic mutual conductance factor which is a summation of the relative mutual conductance over a considerable part of the operating curve of the tube being tested (Figs. 3 and 4). The resulting plate current thus furnishes a composite indication of the mutual conductance between all elements and the plate. Furthermore, there is sufficient current drawn from the tube in all tests so that if the emission is down it will show bad, regardless of the other characteristics. Mutual Conductance is the measure of the change in current to any one element of a tube under test as the voltage to any other element used as a control is varied. Generally this refers to the change in plate current resulting from a given change in control grid voltage.

A tester which reads mutual conductance accurately does not give a good practical application test to power output tubes and oscillators for example, because a true mutual conductance test requires the least possible change in grid voltage while normal use of these tubes requires the maximum possible change. By selecting the desired grid signal from the three available and the proper load for the type being tested the Sylvania dynamic test indicates how the tubes operate in your circuit.

Tubes rejected by the Sylvania Tube Tester may function temporarily in circuits which do not require them to furnish the normal current for that type. However, such tubes can be profitably replaced as preventive maintenance and result in better customer listening pleasure.

Characteristics Which Can Be Tested Individually Are:

Gas

The Sylvania Tube Tester Type 220 uses the proven "grid shift" method of gas testing (Fig. 2). This takes advantage of the fact that a large increase in resistance in the grid circuit coupled with removal of the grid signal will cause a large decrease in plate current in a non-gassy tube. A gassy tube will still draw about the same, or even more plate current, when the grid to cathode resistance is increased. When excessive gas is present in a tube, ions are formed, which decrease the effect of grid bias, and cause high, erratic space currents. A very gassy tube sometimes begins to behave like a thyratron, where the grid loses all control after the tube has fired (when there is DC on the plate). Gas also causes loading in the grid circuit of the tube.

Gas in a tube can result from leakage through glass seals, excessive current requirements in the circuit, which cause the elements to run very hot, or gradual release of

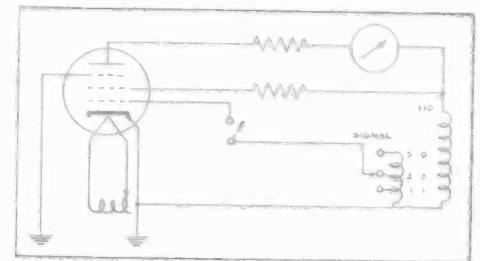

Fig. 2—Simplified gas test circuit. Based on the loss of grid control in tubes which are excessively gassy.

occluded gas from the tube elements with age. In any case the tube should be replaced with a new one for better performance.

Leakage and Shorts

The Sylvania Type 220 Tube Tester uses an exclusive highly sensitive ohmmeter circuit to make the leakage and shorts test. The position of the meter pointer on the "Good-Bad" scale shows the condition of the tube for leakage. Undesirable leakage paths across

FEBRUARY 1950

micas, glass, or other insulating material within the tube, may cause circuit loading and improper bias conditions. Such leakage paths may result from "getter" material depositing as a thin film on micas, cathode sputtering, or similar circumstances. Very high leakage resistance tubes may be selected for special applications if desired. (Often leakage can be reduced by thoroughly cleaning the base of the tube between pins.)

If any two elements within the tube are in contact, the leakage will, of course, be very great, and the indicator needle will drop to zero—a short. Such shorts may result from bowed side-rods, peeled off heater insulation, sagging filaments, particles of foreign material in the tube, etc. The sensitivity of the leakage test is sufficient to show easily noticeable movement of the needle when quick intermittent shorts are present, if the tube is tapped while testing for shorts. Such shorts are one cause of noise and intermittent set behavior so discouraging to a customer while watching his favorite television show.

Open Elements

There are a great many very small spot welds within a tube. It sometimes happens that these welds

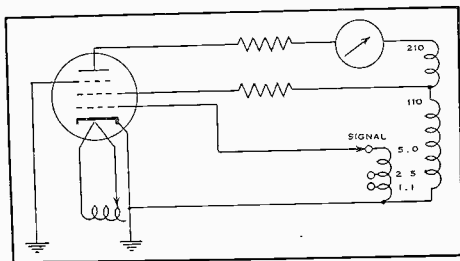

Fig. 3—Composite mutual conductance and emission test for tubes normally operated at approximately 250 volts.

become open due to shock in shipping or handling, or due to thermal expansion within the tube—which causes intermittent set operation. The latter, of course, would not appear until the tube is thoroughly warmed up. The circuit used in the Sylvania Type 220 will immediately indicate an open circuit by a much reduced or zero reading on the meter. There is one exception which must be guarded against, and that is the case of the low mu power tube. Here the steady state plate current is so high (if the

emission is good) that disconnecting the control grid will sometimes leave the indication up in the green part of the scale, although, fortunately, this indication will waver and be unsteady due to accumulated grid charges. Here, however, the gas test on the Sylvania instrument has a valuable secondary function. If the gas test is applied to such a tube having an open grid it is evident that no shift in plate current will occur—which is sufficient to cause rejection of the tube and time of a long drawn out service problem is saved.

Practical Effects of the Various Tube Characteristics:

Low Emission

Poor emission will cause a slump in all characteristics. However, mutual conductance, and rectifier output voltage (for instance) will sometimes measure good until a load is applied, then will slump rapidly. This is like a defective dry cell battery, where the voltage looks good until some current is drawn. In a battery this is caused by high internal resistance and in a tube by lack of available electrons. This is revealed as a "BAD" indication on the Sylvania tube tester.

Mutual Conductance

Mutual conductance, coupled with plate resistance, indicates the maximum attainable amplification possible in the tube. This characteristic is most important in voltage amplifier tubes. It is a complex characteristic to measure, and requires carefully controlled conditions. A tube with low mu or Gm will have low gain indicated as a "BAD" tube on the Sylvania Composite Emission and Transconductance instrument.

Conversion Transconductance measures the effectiveness of a tube as a converter. It is the most complex characteristic to measure. Poor conversion transconductance will give inefficient conversion.

Gas

Gas in a tube usually results in insufficient negative bias, which causes oscillation or loading in voltage amplifiers, and distortion or overheating in power tubes. A tube which has been on the shelf for a long time should be allowed

to "cook" in a receiver for a couple of minutes before judging its quality. Accumulated gas will quite often clear up permanently in this manner, if all normal voltages are applied. A tube which is completely "air" may heat up without any apparent light from the heater. This is because the air conducts the heat away from the filament or heater wires, so that they cannot get hot enough to glow.

Very little gas is permissible in tubes which have high impedances

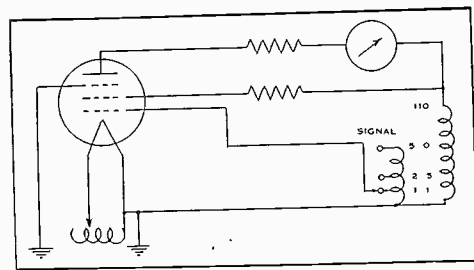

Fig. 4—Composite mutual conductance and emission test for tubes normally operated at approximately 110 volts.

in their grid circuits, such as r-f pentodes. More can be tolerated in most power amplifier tubes, providing there is not excessive resistance in the grid circuit. The proven "grid-shift" method is employed by the Sylvania Tube Testers to reveal this type of faulty tube. Grid resistors in excess of the maximum recommended by the tube manufacturer should not be permitted in resistance coupled amplifiers.

Heater-Cathode Leakage

When the insulating coating applied to the heater wires in a cathode type tube becomes damaged, or contains impurities, it is possible for the resistance between the heater and cathode to decrease and cause an a-c potential from the the heater to appear in part on the cathode. With an ungrounded and un-bypassed cathode, this will result in the introduction of hum into the circuit, particularly in high-gain tubes. Limits for this characteristic vary greatly, depending on the application. The heater-cathode leakage test on the Sylvania Tube Tester makes it possible to select

tubes which are exceptionally good for this characteristic, for use in critical applications like high gain audio amplifiers.

Inter-Electrode Capacitance

This characteristic is not measurable on general purpose tube testers, because of the small capacitances involved (of the order of a fraction of a micromicrofarad). However, it will have considerable effect on the operation of a tube in circuits involving high frequencies. This is an instance where a tube testing good on the tube tester may not function properly. Fortunately, when something has happened to a tube to make its inter-electrode capacitances badly out of line, other characteristics are frequently affected, and this shows up on the Sylvania Tube Tester. Sylvania produces a very elaborate instrument for research laboratories which meets this requirement.

How Tube-Tester Settings Are Made Up: Reference Tubes

All settings on the Sylvania Tube Tester are made from readings taken on sample tubes which have passed all production tests. Averages of readings made on all sample tubes are used to make up the settings, based on a meter reading of 100 for an "average" tube.

Emergency Settings Can Be Made By The Serviceman

All switches on the Sylvania Tube Tester are numbered to correspond to the socket point to which they are connected. This makes it possible to know just what you are doing when you set up to test a tube, by referring to a basing diagram of that tube. Voltages applied and current drawn are proportioned so that an effective test is applied, without damage to the tube. Although it is possible for the serviceman to make up settings for

tubes which are not provided for on the roller chart, it is recommended only for temporary use until official settings are available. New roller charts will be prepared from time to time and will be available at \$1.00 each from the Sylvania Advertising Dept., Emporium, Pa. Watch Sylvania News for announcement of new charts, and for new settings which are published as developments indicate servicemen will require them.

The main objective of proper settings is to pick out tubes which do not come up to production standards. This does not necessarily mean that they will not work in any circuit, but does mean that for best set performance they are not recommended for use in circuits of proper design. Due to the constantly changing requirements imposed by set designers, the tube manufacturer is in a better position to make up the tests most likely to do the job of eliminating tubes which will not function properly in all known circuits.

SERVICE HINTS

Delco R - 1409 Burning Out 3Q5GT: Every serviceman has been puzzled by AC-DC battery sets which frequently burn out the same tube when operated on AC current and yet tests will reveal nothing abnormal with the filament voltage of that tube.

I had a set on which another serviceman had worked on for over a year and wasn't able to repair. I had a sweet time myself to find the trouble. The radio was a Delco Model R-1409 and it was plagued with the habit of burning out the 3Q5GT tube. None of the other tubes in the set would be harmed in the least. After burning out a new tube I decided to substitute a resistor of the same resistance as the 3Q5GT and to connect my voltmeter across its terminals and see what developed. I found that the direct current voltage was below normal and so I switched my meter to AC and found that the voltage was about 15 volts. Subsequent study of the circuit diagram revealed that the negative terminal lead of the electrolytic filter condenser had

opened. This had the effect of placing the filter condensers in series across the filament supply resistor or in parallel with the resistor. The AC component of the rectified current of the 35Z5 tube flowed readily through these condensers to the 3Q5GT tube and from it to the B- ground through the condenser which by-passed the 3Q5GT filament.—Donald Slattery, Chadron, Nebraska.

* * *

Philco 35-1285 Record Changer: Reproduction of some records was badly distorted while others were clearly audible. It was discovered that records in the upper portion of the audio frequency range reproduced satisfactorily while those in the lower portion of the audio frequency range were distorted and muffled. Apparently the jewel and mirror rubber bearing cushion had aged preventing the lateral movement of the stylus in the record groove to faithfully reproduce the lower audio frequencies; con-

sequently the varying amounts of light reflected from the mirror to the selenium photoelectric cell did not follow in true form that of the sound waves on the record grooves. Normal operation was achieved by replacing the jewel and mirror assembly.—Michael T. Haddad, Wayne, Michigan.

* * *

Substituting a PM Speaker for an Electro-dynamic Speaker: When a customer is anxious to have his set back quickly and you do not have the necessary small filter choke to do a good job you can keep him satisfied by fastening the field coil and the pole piece in some out of the way spot as a temporary measure. It may make it more convenient to mount the coil and pole piece if you remove the cone and cone bracket. Most of us generally have an assortment of PM speakers on hand so that there should be little or no delay in making the necessary repairs.—Ryall H. Gibson, Punxsutawney, Pennsylvania.

New Type 500 TV-FM Sweep Signal Generator

This new Sylvania test instrument simplifies the servicing of television and f-m receivers and reduces the time necessary for completion of the work. An oscilloscope is used to view the curve.

THE Type 500 TV-FM Sweep Signal Generator is the latest addition to the Sylvania line of test equipment designed especially for servicing television and radio receivers. This new sweep signal generator is used as a general purpose signal source and when an oscilloscope is used in conjunction with it, the frequency response curves of the receiver circuits are produced on the screen of the 'scope. The work of aligning the i-f and r-f circuits is very much simplified by having the response curve visible and having the effects of any adjustments shown as soon as they are made.

The frequency range of the Type 500 is from 2 megacycles to 230 megacycles and the maximum output voltage is 0.1 volt, more than adequate for checking the r-f and i-f circuits of television and f-m receivers. The output signal is similar to an f-m carrier signal in that the frequency varies about the center frequency at the rate of 60 cycles and by an amount ranging from zero, or fixed frequency, up to 15 megacycles. This means that the response of any circuit may be checked over any bandwidth up to 15 megacycles. For instance, in an f-m receiver the response of the r-f and i-f stages is important from approximately 100 kilocycles below the center frequency to approximately 100 kilocycles above the

center frequency. The Type 500 Sweep Signal Generator is set to the carrier frequency (between 88 and 108 Mc.) and r-f stages or to the intermediate frequency (generally 10.7 Mc.) for the i-f stages with a sweep width of 200 kc. The signal passes through the pass band of about 100 kc. on either side of the nominal or center frequency at the rate of 60 cycles. With an oscilloscope connected to the output

of the circuit in question through a rectifier (generally the detector of the receiver) and synchronized with the sweep signal from the Type 500, the response curve of the circuit will be traced on the screen of the 'scope.

A synchronizing voltage and a phasing control is provided in the Type 500 so that the sweep of the oscilloscope may be synchronized with the sweep of the signal output. It is necessary that the sweeping of the signal through the pass band be synchronized with the horizontal sweep of the scope to produce the response curve properly.

The Circuit

The circuit of the Type 500 Sweep Signal Generator consists of a beat-frequency oscillator with a frequency modulated fixed oscillator operating at a center frequency of 130 megacycles and a variable oscillator operating at frequencies from 132 megacycles to 360 megacycles. The frequency of the "fixed" oscillator is modulated by a reactance tube circuit. The sweep width is variable up to 600 kilocycles (deviation up to 300 kilocycles on each side of the center frequency) on one sweep band and up to 15 megacycles (deviation up to 7.5 megacycles) on the other. The output signal is the difference frequency between the "fixed" and variable oscillators. Because the frequency of the "fixed" oscillator is varying back and forth

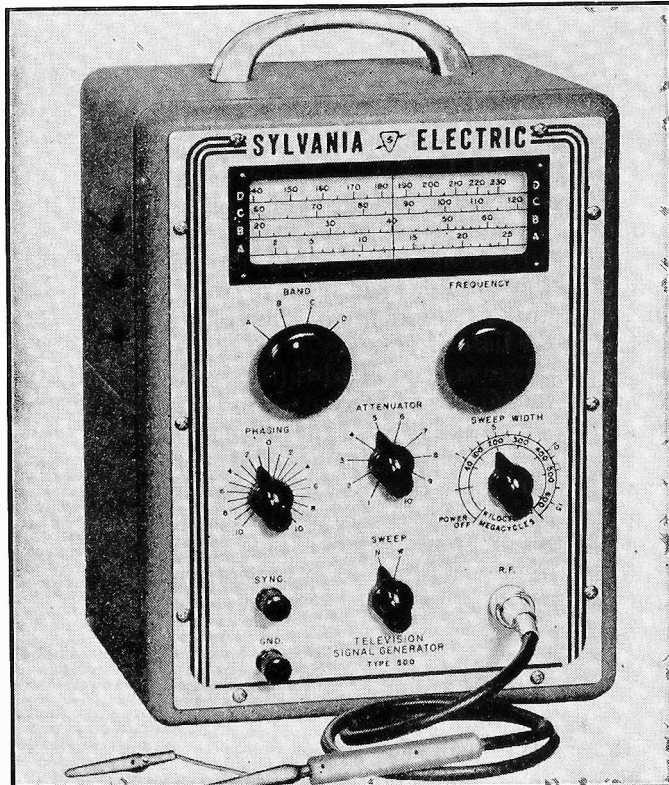

The new Sylvania Type 500 TV-FM Sweep Signal Generator is used for visually checking the response curves of i-f and r-f stages of television and f-m receivers. The frequency range is from 2 to 230 Mc. and the sweep width is variable up to 15 Mc.

about the center frequency, the output signal will also vary by the same amount. This is a frequency-modulated signal with a modulation frequency of 60 cycles and a sweep width as desired by the operator. The entire frequency range is covered on fundamentals.

A 60-cycle synchronizing and sweep signal is derived from the power source to be fed to the horizontal deflection amplifier of the oscilloscope used in conjunction with the Type 500 Sweep Signal Generator. A phase-shifting control is provided so that the sweep of the scope may be synchronized with the sweep of the output signal.

Alignment of Television Receivers

To observe the i-f response curve of a television receiver, the oscilloscope is connected to the output of the video detector. It is important to note that the oscilloscope bandwidth requirements bear no relation to the bandwidth of the circuit under test in this type of response measurements.

The output lead of the Type 500 Sweep Signal Generator is first connected to the grid circuit of the last video i-f stage with the signal frequency set approximately to the center frequency of the i-f stage, as it is given by the receiver manufacturer. The sweep width should be set on the wide position and at about eight to ten megacycles. Adjust the phasing control to give a single sharp curve.

The tuning of the video i-f output transformer is adjusted to give a curve of the best shape and width free of irregularities, and when used with a marker generator, to obtain marker pips at the points designated by the manufacturer of the receiver under test. The method of using the Sylvania Type 216 FM-AM Signal Generator as a marker generator is described elsewhere in this issue.

After the last video i-f stage is properly adjusted, move the output leads of the sweep signal generator and the marker generator, if one is used, to the grid circuit of the preceding stage. The scope connection remains unchanged. Adjust the preceding i-f transformer for the best response curve in the same manner. The final video i-f should not be touched during this operation.

Continue this operation on each i-f stage until the signals (from the sweep signal generator and the marker) are applied to the grid of the converter tube, tuning the i-f transformers for the best response curve, amplitude and marker pip location. With a receiver badly out of alignment, it may be advisable to repeat the entire procedure in the same order. It is important that the sound traps be adjusted during this checking for minimum sound i-f response at the video detector.

Many television receivers have been sold which use stagger-tuned video i-f stages. The overall alignment of such stages may be visually checked in the manner described above with the Type 500 and the marker generator outputs connected to the mixer grid. Minor adjustments may be made in the various stages to improve the response curve and the location of the marker pips. But, if the curve shows more than minor misalignment it may be necessary to align each stage individually using a signal generator such as the Sylvania Type 216 with a vacuum tube voltmeter such as the Sylvania Polymeter connected at the detector.

Inter-Carrier Sound

For alignment of the i-f stages of a television receiver having inter-carrier sound the normal procedure should be followed, but with consideration for the wider pass band used. When a marker is used, a noticeable pip should appear for the sound intermediate frequency and a strong one for the video intermediate frequency. In all cases, however, the bandwidth should not include the adjacent sound channel which is only 1.5 megacycles below the video carrier (except between Channels 6 and 7). Note that in the video i-f stages the adjacent sound frequency is above the video frequency due to inversion of the pattern in the converter stage.

R-F Stages

The r-f stages should be checked for alignment after the i-f stages have been correctly aligned. With the oscilloscope still in the video detector circuit, apply a signal from the Type 500 to the antenna. The frequency should be at the frequency of the channel being checked and

Do You Know Your Test Equipment?

Efficient test equipment is necessary for the profitable servicing of radio and television receivers. The full line of Sylvania test instruments is listed below.

- Type 132 7-inch Oscilloscope
- Type 145 Audio Oscillator
- Type 216 FM-AM Signal Generator
- Type 219 Counter Tube Tester
- Type 220 Portable Tube Tester
- Type 221 Polymeter
- Type 500 TV-FM Sweep Signal Generator

the sweep width should be on the wide band at about eight to ten megacycles. If the response curve is much degraded from that obtained for the i-f stages, the r-f stages should be readjusted to give the best shape to the response curve. This procedure should be undertaken for each of the channels.

To obtain the response curve of the r-f stages alone, independent of the i-f stages, a demodulator probe or the mixer tube may be employed as a detector as outlined by some manufacturers of television receivers. The oscilloscope is then connected at this point in the circuit.

The response curves of the sound section of television receivers and also f-m receivers may be checked by the same method using appropriate frequencies and sweep widths. The Type 500 Sweep Signal Generator may be used to check the response curves of any circuit in any type of electronic equipment as long as the operating frequency lies within the range between two and 230 megacycles.

The Type 500 TV-FM Sweep Generator will enable the serviceman to reduce the time necessary to service television and f-m receivers and thereby increase the number of service jobs he can perform in a week's time and increase the income of his business establishment. It is a worthwhile addition to the growing line of Sylvania service test instruments designed especially to enable the up-to-date serviceman to perform more efficient work for his customers.

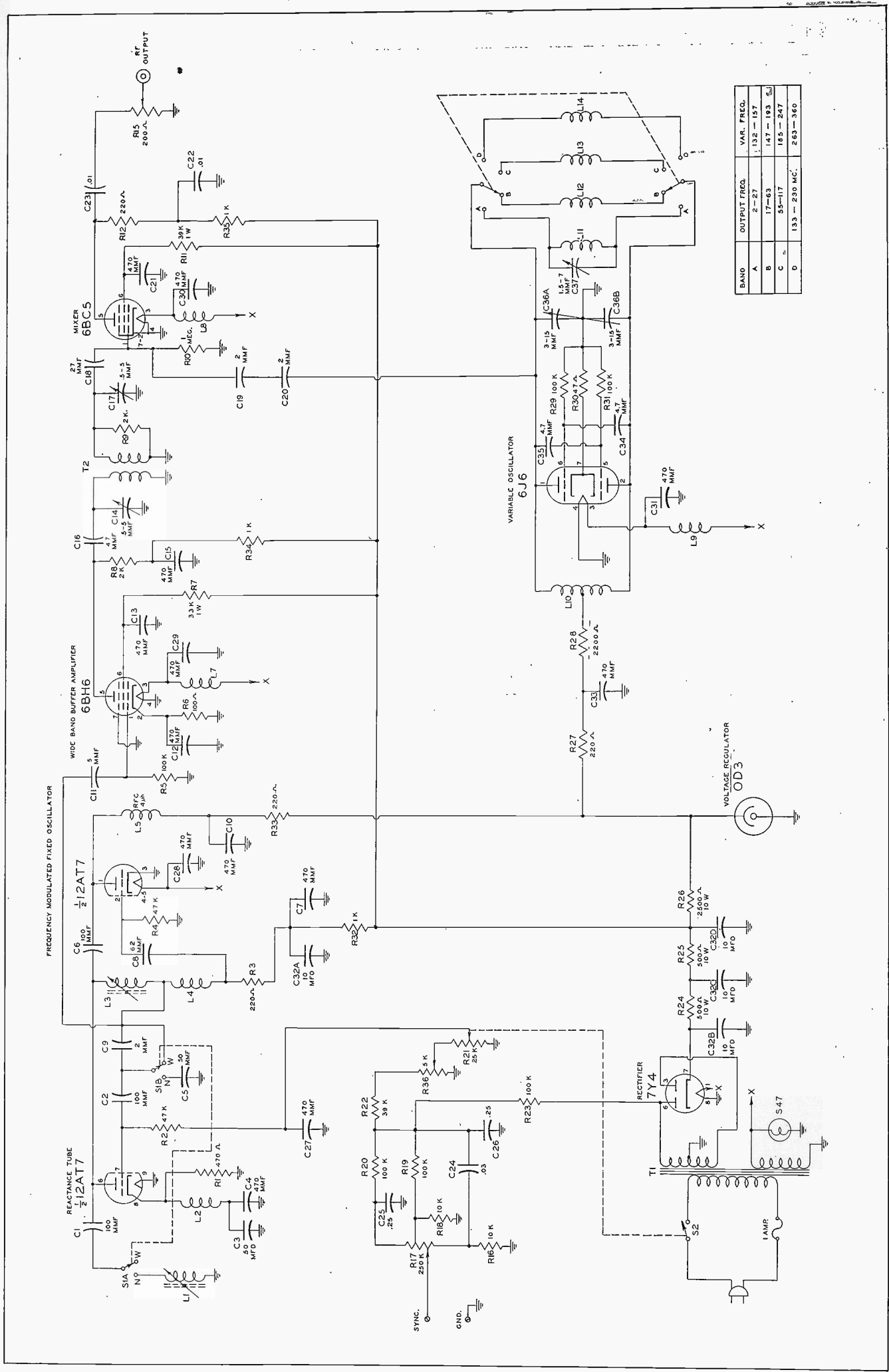

BAND	OUTPUT FREQ.	VAR. FREQ.
A	2-27	132 - 157
B	17-63	147 - 183
C	55-117	165 - 247
D	133 - 230 MC.	2 63 - 360

Circuit diagram of the Type 500 TV-FM Sweep Signal Generator. It consists of a beat-frequency oscillator in which the fixed oscillator is frequency modulated at 60 cycles by the reactance tube

circuit. The deviation from the center frequency, or the sweep band width, is controllable from zero to 600 kc. in the narrow bandwidth range and up to 15 Mc. in the wide bandwidth range.

TYPE 216 FM-AM SIGNAL GENERATOR AS A TELEVISION MARKER GENERATOR

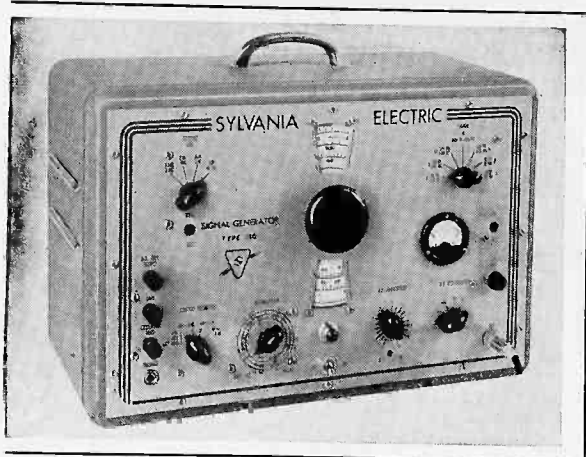

Fig. 1. The Type 216 FM-AM Signal Generator has many uses in the service shop. The accuracy of its frequency calibration makes it suitable for use as a marker generator in television servicing.

Owners of the versatile Sylvania Type 216 FM-AM Signal Generator may use it as a television marker generator in addition to the many other uses for which it was originally intended. It is used in conjunction with the Sylvania Type 500 TV-FM Sweep Signal Generator or equivalent unit and an oscilloscope such as the Sylvania Type 132 in the alignment of i-f circuits. The block diagram of Fig. 2 and the ideal i-f response curve with the marker pips of Fig. 3 illustrate the method.

It is usually necessary to couple the Type 216 to the circuit through a very small condenser, or perhaps a loop. It is important to keep the amplitude of the output as low as possible to avoid faulty representation of the response curve. The sweep generator is set approximately to the center of the total i-f band with a sweep of about eight to ten megacycles so that the entire frequency range of the i-f circuits may be observed on the 'scope. When the pattern is obtained on the 'scope

and the i-f transformers adjusted for good shape of the curve, set the frequency of the Type 216 to one of the frequencies listed below. The modulation, of course, should be set at zero.

Video intermediate frequency (Consult the manufacturer's service notes for the exact value. It is close to 26 Mc.)
Sound intermediate frequency (4.5 Mc. less than video intermediate frequency)

High frequency edge of i-f channel
Low frequency edge of i-f channel

The complete pattern obtained on the 'scope is compared with the ideal pattern of Fig. 3 using the marker points listed above, one after the other.

The Sylvania Type 216 FM-AM Signal Generator finds wide usage in the alignment of r-f and i-f amplifiers of both f-m and a-m receivers as well as f-m detectors. The modulated output signal also makes it very useful in giving a receiver an overall check.

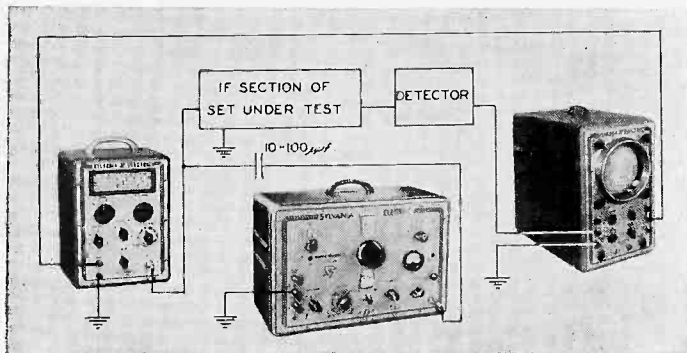

Fig. 2. Diagram showing the method of using the Type 216 FM-AM Signal Generator as a television marker generator.

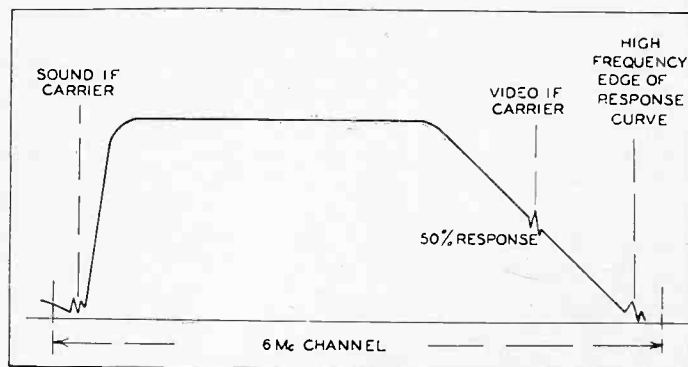

Fig. 3. Standard i-f response curve showing the locations of marker pips for video and sound intermediate frequencies.

Sylvania Service Meeting Schedule

Clarence Simpson, popular Sylvania Lecturer, will continue the series of Sylvania Service Meetings during March and April. All servicemen are cordially invited to be guests of Sylvania and the sponsoring distributors. The schedule is listed below.

March 20, 7:30 P.M.—Alvin Hotel
Tulsa, Okla.
Sponsor—Radio, Inc.

March 22, 7 P.M.—Hotel Biltmore,
Oklahoma City, Okla.
Sponsor—Radio Supply, Inc.

March 23, 7:30 P.M.—Meadowbrook
School, 4330 Meadowbrook Drive,
Fort Worth, Texas.
Sponsors—Bill Sutton's Wholesale Elec-
tronics and Fort Worth Radio Supply Co.

March 24, 7:30 P.M.—Raleigh Hotel,
Waco, Texas.
Sponsor—The Hargis Co.

March 27, 8 P.M.—Carter Music Audi-
torium, 1201 Leeland Ave., Houston,
Texas.
Sponsors—Straus-Frank Co. and Sterling
Radio Products Co.

March 29, 8 P.M.—Y.M.C.A. Building,
417 S. Broadway, Corpus Christi, Texas.
Sponsor—Electronic Equipment & Engi-
neering Co.

March 30, 8 P.M.—Bolivar Building,
La Villita, San Antonio, Texas.
Sponsor—Mission Radio, Inc.

March 31, 7:30 P.M.—Austin Hote'
Austin, Texas.
Sponsor—The Margis Co.

April 11, 7:30 P.M. Alms Hotel,
Cincinnati, Ohio.
Sponsor—United Radio, Inc.

April 13, 7:30 P.M.—Fitzpatrick Elec.
Supply Co., 444 Irwin Ave. at Wood,
Muskegon, Mich.
Sponsor—Fitzpatrick Elec. Supply Co.

April 14, 7:30 P.M.—YWCA, 146 South
High Street, Akron, Ohio.
Sponsor—Warren Radio Co.

SYLVANIA NEWS

APRIL 1950

COPYRIGHT 1950
SYLVANIA ELECTRIC PRODUCTS, INC.

EMPORIUM, PENNA.

BOB PENFIELD, EDITOR

VOL. 17, NO. 4

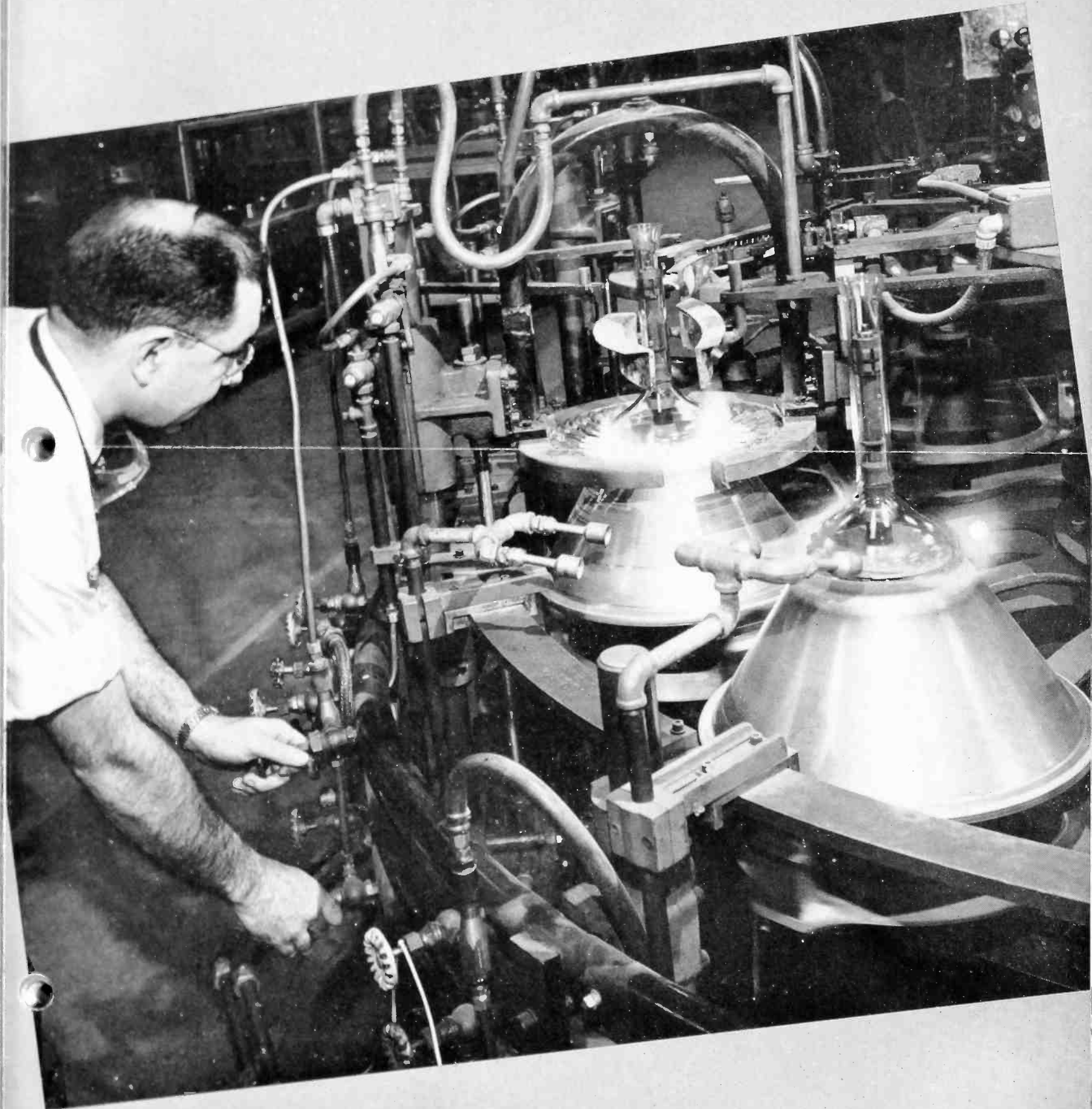

W. E. Poor, Board Chairman, Dies

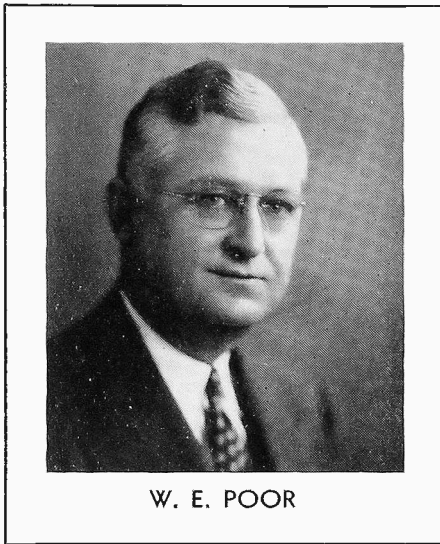

W. E. POOR

Walter E. Poor, chairman of the board of Sylvania, died April 4th in the St. Luke's Hospital, New York.

A native of Salem, Mass.; Mr. Poor was graduated from Massachusetts Institute of Technology in 1908 with the degree of electrical engineer. After a period spent as electrical engineer for the Boston Elevated Railway, he joined his brothers in 1911 in the manufacture of electric lamps at Danvers, Mass. The Hygrade Lamp Co., predecessor of Sylvania Electric Products, after 10 years spent in making new and renewed carbon filament lamps, started in 1911 to make the new tungsten filament lamp. As electrical engineer for Hygrade, Mr. Poor took over the development and production of tungsten lamps. He later became vice-president and general manager. In 1940 he was made executive vice-president and in 1943 was elected president. He became chairman of the board of Sylvania in 1946.

At the time of his death, Mr. Poor was a trustee of Salem (Mass.) Hospital, director of Junior Achievement, Inc., director of the Sound-Scriber Corporation, New Haven, and member of the Committee on Corporations of the Development Fund of Massachusetts Institute of Technology.

Town Meetings For 60 TV Areas

A national program representing one of the most extensive non-commercial, cooperative efforts by big industry to help small businessmen has been announced by R. C. Sprague, Chairman, Town Meetings Committee, Radio Manufacturers Association.

The project will attempt to improve sales, merchandising and advertising, and business management practices among radio and television dealers in some 60 marketing areas throughout the nation, Mr. Sprague said.

"For the first time in the history of the electronics industry—or, so far as I know, any industry," he declared, "Manufacturers will team up to make available to retailers the soundest, most comprehensive, and most effective information available on how to run a business and make a profit."

The program will be financed jointly by leading television manufacturers, without regard for competitive advantage. Ultimate objective is to aid the television set owner and purchaser, as well, by assuring him satisfaction with his instrument.

Known as the Town Meetings of Television Dealers, the project stems from the recent successful two-year program of the Radio Manufacturers Association to stimulate radio technicians to upgrade themselves to the servicing of vastly-more-complicated television.

Toward the end of this program, the RMA authorized research into

the possibility of using the same technique of meetings, on a wider scale, to help the dealer in his conversion from radio to handling television sets of far greater complexity, cost, and value.

Following approval of the research by the RMA, the resulting plan was submitted to set manufacturers for their approval or rejection. They were asked and agreed cooperatively to underwrite national expense of preparing four educational slide-film presentations for use in the 60 marketing areas in the two months just prior to this 1950 fall season. Local expenses will be borne by co-operating distributors. Total cost to manufacturers and distributors is expected to be "substantially more than \$100,000." Mr. Sprague said.

Subjects to be covered include Sales, Merchandising and Public Relations, Store Management, and Operating a Profitable Service Department.

"Research is extending not only throughout the television industry—which is pooling its experience—but into other industries such as the automotive and appliance fields which have undertaken similar, if more limited, programs in the past with great success.

"When the films are completed, they will be displayed and discussed at meetings in every television center in the country. Meetings will be free to dealers, as all Town Meetings have been in the past.

Larger TV Tubes

Sales of large-type television picture tubes to set manufacturers reached a new peak in February as 96% of all tubes sold for new TV receivers were 12 inches or larger. The report issued by the RMA also showed that 35% of TV picture tubes sold to set makers were 14 inches or larger.

February sales of TV picture tubes to manufacturers totaled 427,189 units valued at \$10,685,295. Sales in February to users and distributors for renewal purposes totaled 16,783 tubes valued at \$389,719. The sale of TV picture tubes reflected a slight drop from January sales.

ON THE COVER

Sylvania's modern rotary tube-sealing equipment in the process of bonding glass necks to metal cones of 16 inch picture tubes. Advanced production engineering, scientific quality control, and precision fabrication of parts are factors behind the development of this automatic machine . . . a machine which is only one step in the efficient mass production methods responsible for the manufacture of more, better and larger Sylvania television picture tubes.

SYLVANIA NEWS

Merchandising
Section

APRIL 1950 — VOL. 17, NO. 4

COPYRIGHT 1950
SYLVANIA ELECTRIC PRODUCTS INC.

"The Four Summer Months Will Be BIG PROFIT MONTHS"

The traditional "summer slump" in the radio and television repair business is no longer the nemesis of service dealers throughout the country. In spite of the long standing rule that hot weather automatically calls for a reduction in service business, the Sylvania Coordinated Advertising Campaign for service dealers has proven that summer business can now be a profit business.

Typical of the radio dealers who have used the Sylvania advertising campaign to help stimulate their business in slow months is Albert Gale of Gale Radio and Television Labs, New Rochelle, N. Y. Last summer, Gale made a test of his trading area with the Sylvania Campaign. Through the tests made with the campaign, Gale found that his business increased 30% in areas where the campaign was used.



Albert Gale, Gale Radio, New Rochelle, N. Y. uses Sylvania Coordinated Advertising Campaign to help increase his business. Letter below tells success he has had with the coordinated advertising campaign.

To test the effectiveness of the campaign, Gale sectioned off a map of New Rochelle. The direct mail postal cards from the campaign were mailed to certain sections. The other sections of the city were not covered with promotional material. After he ran the campaign for the four summer months, Gale discovered that he had received 30% more business from the test areas which had been receiving the cards.

In summing up his experience about the campaign Gale said, "We believe your campaign is the best insurance we can buy against an otherwise normal summer slump in our radio and television service business." This year Gale has doubled his order for postal cards in the campaign for May, June, July and August.

The typical example furnished by Gale Radio is but one of the many service dealers who have found that the Sylvania Coordinated Advertising Campaign stimulates service business. This campaign furnishes all of the necessary tools required to do a complete promotional job in any community. It is a complete package promotion created especially for radio and television service dealers.

For each service dealer who par-

(Continued on page M-16)

GALE RADIO & TELEVISION LABS
601 NORTH AVENUE
NEW ROCHELLE, NEW YORK

Guaranteed Radio Service

ALL MAKES AND MODELS
COMPLETE RADIO REPAIR SERVICE



January 23, 1950

Sylvania Electric Products Inc.
Advertising Department,
Emporium, Pa.

Gentlemen:

Last summer, we purchased your Coordinated Advertising Campaign, complete with 2,000 postal cards. We sectioned off a map of New Rochelle and mailed the postal cards to certain sections. Then we kept track of our service business during the summer months. We found we received 30 percent more service business from the sections which received postal cards than from the sections which didn't receive cards.

Here is our order for Sylvania's Coordinated Advertising Campaign for May, June, July and August, 1950. We believe your campaign is the best insurance we can buy against an otherwise normal summer slump in our radio and television service business. This year, May, June, July and August are going to be big profit months for us, thanks to your penny-a-postal card campaign.

Very truly yours,

ALBERT GALE
Gale Radio & Television News

bt

WE USE AND RECOMMEND SYLVANIA RADIO TUBES

How To Put Salesmanship In Your Shop Windows



Typical installation of the new Sylvania Window Valance. This attractive window decoration features the Sylvania Radio Television Service decal, along with dealers own name. Valance is completely installed by professionals. Sylvania Distributors can give you more information about this handsome addition to your store windows.

As a further tie-in with Sylvania's intensive advertising of radio and television service, a new window valance is now available to service technicians. The new valance is a personalized identification of your business with Sylvania national and local advertising of the service business.

The valance is a brilliantly colored trim for store windows. It is printed with your own store name and includes the famous Sylvania

windows in your store will be completely and professionally decorated. The valance is made of colorfast pigments which will not fade or peel. They will make your windows attractive for years.

Brilliantly Colored

Bright red and yellow background of the valance has been selected by experts as the best to give you maximum attractiveness and display value. The installation of the

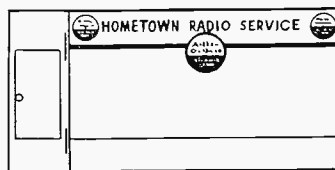
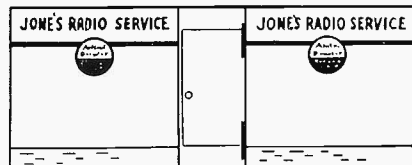

Complete, individualized installation of the Sylvania window valance, installed in your window by professional decorators to your specifications is \$10.00. Your Sylvania Distributor will make complete arrangements for the installation. See him today and ask for more information about this new tie-in with the intensive promotion offered by Sylvania for radio and television servicemen.

decal which is featured in all the advertising material for service dealers. Colors on the valance include red, yellow and green. These are the same colors included in the Sylvania decal.

Installed by Professionals

Each valance is installed by professional window decorators who will call at your store and do the complete installation, custom-made for your windows. All display

Sylvania valance does not interfere with window lighting or any method of window cleaning.

Installation of the valance by professional decorators will be made in your shop within 30 days after your order has been placed with your Sylvania Distributor. In some remote sections of the country this schedule may vary, but not in most areas. Make sure you add this colorful and sales attracting window trim to your store. It

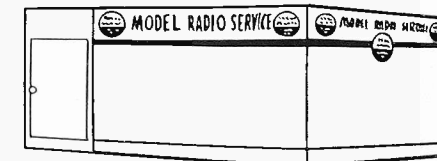

Easy Livin'

Study your prospective customers, then study your competitors, and decide what features you can sell that your customers need and your competitors are not supplying.
—Robert Perry, U. S. Department of Commerce.

The information in Sylvania News is furnished without assuming any obligations

Technical Editor A. V. BALDWIN

TELEVISION SERVICING by PICTURE ANALYSIS-II

By C. Masucci and W. B. Whalley
Photographs by L. Ankersen

This is the sixteenth of a series of articles on Television by Sylvania engineers. Part one of Television Servicing by Picture Analysis appeared in the January issue of Sylvania News.

Careful inspection and analysis of the picture produced on the screen of a television receiver give an excellent indication of the quality of the receiver's performance. The test pattern is especially designed with two vertical wedges of converging lines, two horizontal wedges of converging lines, and several circles of various shades between black and white. Defects in the receiver become apparent as a result of distortion in the shape or shading of the circles or the resolution of the vertical and horizontal wedges. The quality of the focusing is indicated by the sharpness of the scanning lines over the entire face of the picture tube. The resolving power of the receiver is indicated by the clarity of the converging lines as they approach the circles in the center of the pattern.

The value of the test pattern in localizing troubles in a television receiver will be appreciated more and more as it is used. It is realized, of course, that test patterns are not transmitted during a large portion of the day. Consequently, a compromise must be made and re-

CONDITION—The vertical lines are wavy. **CAUSE**—Excessive hum pickup (60 cycles) in the synchronizing circuits.

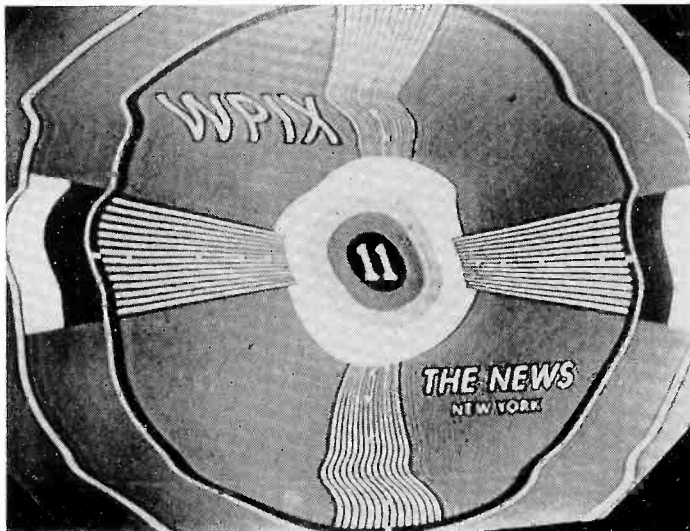

Any variation in the size, shape, or shading of any portion of this typical test pattern indicates defective operation of the receiver. Careful inspection will often help point out the troublesome circuit.

ceivers serviced using program material for the analysis.

Troubles in the horizontal synchronizing circuits are illustrated in the accompanying photographs and some of the causes are discussed. It is important to note that the trouble is localized to a section of the receiver and there remains the problem of finding its exact location in the circuit. Standard test equipment is usually necessary for the precise location of circuit troubles.

It is important to keep in mind the functions of the various sections of the television receiver while in-

CONDITION—Loss of horizontal synchronization. **CAUSE**—Horizontal hold control or AFC circuit out of adjustment.

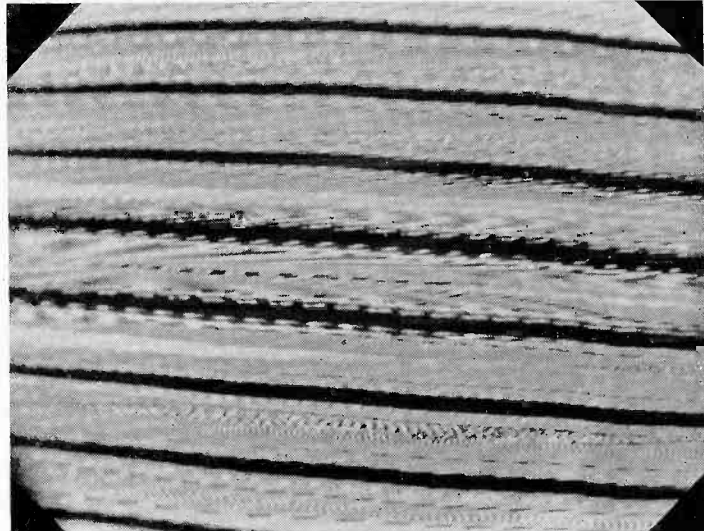

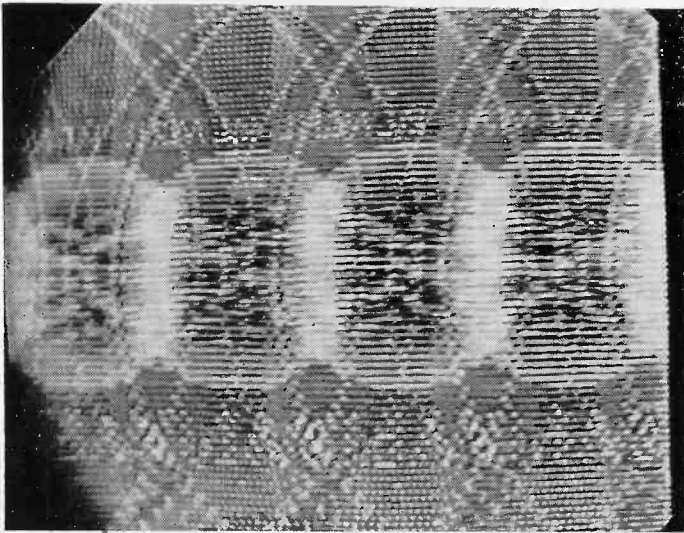

CONDITION—No horizontal sync. Horizontal hold control is ineffective. CAUSE—(A) Horizontal frequency control coil incorrectly adjusted. (B) Defective frequency control tube.



CONDITION—On verge of losing horizontal synchronization. CAUSE—(A) Misadjustment of hold control or phase control. (B) Defective horizontal sync amplifier tube or component.

specting the pattern. The experienced serviceman having a good knowledge of the detailed operation of each section of the receiver can often locate the troublesome section at a glance. He will then track down the trouble to a single stage, and then to a single component. To do television receiver servicing rapidly enough to be profitable, the serviceman must develop a method or procedure to enable him to go through the necessary steps quickly. He must be methodical and orderly. He must plan his work well. Above all, he must use his ingenuity.

The successful television serviceman will first of all become familiar with the operation of the various circuits and with the effects of their improper functioning. He will learn to recognize the symptoms of the failure of any circuit to perform its function. He will learn to use and trust the operation of test equipment

designed especially for his use. In short, he will extend his experience and ingenuity in radio servicing to the new and fascinating field of television. The reader is referred to the list of books printed with the first installment printed in the January issue.

The photographs used in this series are to illustrate the results of defective operation of television receivers and do not in any way indicate any shortcomings in the quality of transmission of any television station. Television stations WPIX, and WJZ-TV have given their full permission to use the photographs of their respective test patterns and their courtesy is very much appreciated by SYLVANIA NEWS.

The next installment of this series will discuss the causes of troubles which appear in the video circuits and power supply. This will be presented in an early issue of SYLVANIA NEWS.

CONDITION—Pattern horizontally keystoneed with the long dimension at top. CAUSE—Short from the low side to center point of horizontal winding of the deflection yoke.

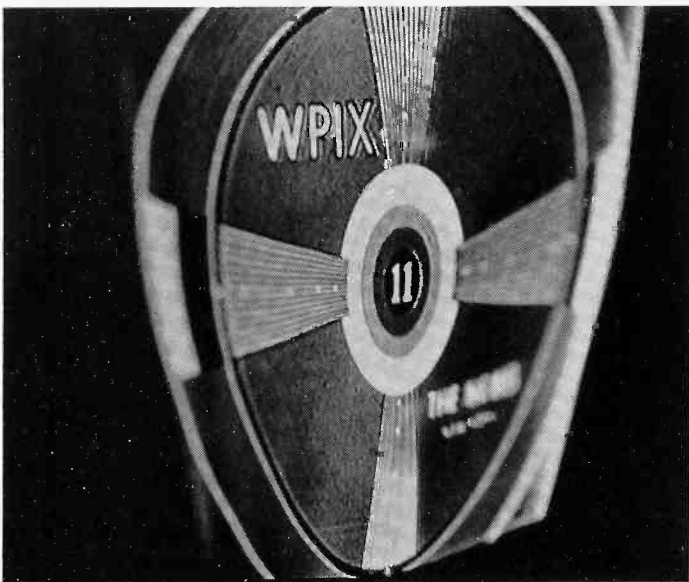

CONDITION—Pattern horizontally keystoneed with the short dimension at top. CAUSE—Short from the high side to center point of horizontal winding of the deflection yoke.

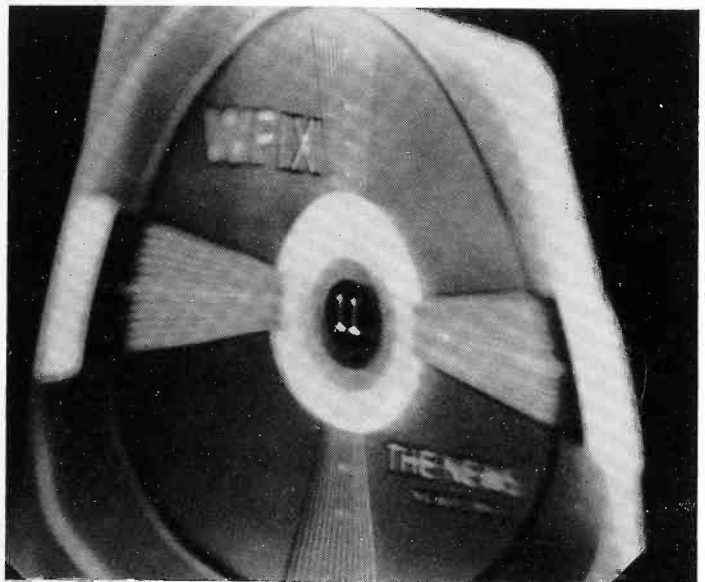



CONDITION—The pattern is non-linear in the horizontal direction with bright vertical bar on left side of screen. CAUSE—Open condenser on one side of the linearity coil.



CONDITION—Several bright bars at left side of the screen cause the pattern to appear wrinkled. CAUSE—Oscillation in the yoke due to an open or wrong value of condenser across the top half of the horizontal winding of the yoke.



CONDITION—Shadow around part or all of outer edge of pattern. Poor focus over entire screen. CAUSE—Deflection yoke is not as close to the cone of the tube as it will go. Also, the focus coil may be too close to the yoke.



CONDITION—Pattern is non-linear in the horizontal direction. CAUSE—(A) Horizontal drive control or linearity coil out of adjustment. (B) The damper tube is defective.

YOUR POLYMER AND HIGH VOLTAGE

High-voltage circuits up to 30,000 are readily serviced with the Sylvania Polymer and a DC Voltage Multiplier Probe shown in the accompanying photograph.

Television receivers normally have voltages in the range of 10,000 volts applied to the picture tube and in those with larger picture tubes or with projection tubes voltages of 20,000 and greater are frequently encountered. Transmitters used by police departments, hams, taxi operators, etc. use high-voltage power supplies and offer possibilities of increased business to the well

equipped service shop. Many types of industrial electronic equipment and photographic lighting equipment also use high-voltage.

If you own the Type 221 Polymer get the Type 223 DC Voltage Multiplier Probe for voltages up to 10,000 volts or the Type 225 for measurements up to 30,000 volts. Or if you own the Type 134Z get the Type 222 for 10,000 volts or the Type 224 for 30,000 volts.

These probes are obtainable at your Sylvania distributor at the following prices: For Polymer

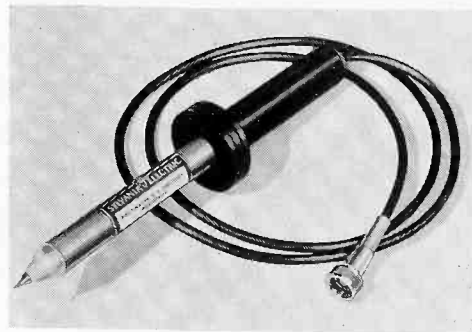

Type 221—Type 223, \$9.95; Type 225, \$12.50. For Polymer Type 134Z—Type 222, \$9.95; Type 224, \$12.50.

SERVICE HINTS

Squeaks And Howls In AC-DC Radios: If the usual methods of realignment, checking bypasses, etc. do not get satisfactory performance I have found that using a Sylvania Type 1N34 crystal in place of the diodes of the 12SQ7 will clear up the trouble. Disconnect diode lead from tube and connect to crystal, cathode end of crystal goes to ground.

It seems as though removing the IF from the tube prevents the coupling which causes the squeals.—Roy E. Madden, Penns Grove, New Jersey.

* * *

Keeping Your Resistor Stock: It has been found very convenient where a fellow doesn't happen to have a regular resistor storage cabinet that an ordinary partitioned drawer in a small cabinet could be used by storing the resistors by their "Multiplier color" such as black band, yellow band, red band, etc. Thus, black band resistors would include 10 to 100, brown band 100 to 1000, red band 1000 to 10,000, etc. This method has been very helpful to me in picking out resistors in a hurry.—Emil Gisel, Fort Worth, Texas.

* * *

Freed-Eiseman Model 46 FM: We have had a few of these sets in the shop recently in which the complaint was that the FM played on

a powerful local station but other FM signals could not be picked up. It was found that the resistor going to the plate of the squelch tube, 6J5, is shown on the schematic as a 240 K but was actually a 24 K. Rectifying this production error brought in over a dozen stations on all these sets.—Richard Blais, Berlin, New Hampshire.

* * *

Firestone Model 4-A-68: In several cases I have found this receiver noisy as a result of the 250 mmfd mica condensers. There are three of them in the set and almost always two of them were bad. They checked OK on a condenser checker, showed no leakage or capacity change. They were found to be defective only by an insulation resistance test. The trouble was difficult to locate because there were three condensers in three different circuits causing it. If any of these condensers are found bad it would be advisable to replace all of them to prevent call backs.—Russell M. Summerville, Granger, Indiana.

* * *

Use For A Hypodermic Needle In Service Shop: The syringe can be filled with carbon tetrachloride, or any liquid, and shot under great pressure into small places such as tube sockets, switch contacts, etc. A fine stream can be directed

between condenser plates, and even trimmers cleaned this way.

Many times noise is caused by dried grease and dirt in variable condenser bearings. If the needle is placed in the bearing and 3 or 4 cc. of carbon tet shot into it the dirt will come out in a hurry. Then the bearing can be properly lubricated.

The needle can be filled with oil and used to oil those hard to get at places, or to apply a very small amount to fine parts.

Cement solvent also can be applied in very small amounts to loosen a few coil turns, or in speakers when an excess of solvent would mess things up.

I have found this tool indispensable in my shop and consider it a great time saver. You too will find many uses for this item.—Russell M. Summerville, Granger, Indiana.

* * *

Hint For Working On Car Antennas: To prevent dropping hardware, such as nuts, lock washers and your tools down into and between the braces, when you are installing antenna, after removing the kick plate stuff a rag into hole. If you drop anything it cannot fall down to the bottom out of your reach.—Louis Grisham, Los Angeles, California.

Sylvania Service Meetings Attract Many Servicemen

Clarence Simpson, the popular and able Sylvania lecturer, discusses television servicing problems with the many servicemen attending the Sylvania Service Meetings now being held with the cooperation of Sylvania distributors in many cities throughout the country. Since the first of January there have been 25 meetings in as many cities with a total attendance of over 3000. The greatest attendance at any one meeting was 250 with the average being about 120. Some men traveled as far as 150 miles to be there.

All those engaged in the servicing of radio and television receivers, for

commercial as well as home use, are cordially invited to attend these Sylvania Service Meetings as guests of sponsoring Sylvania distributors.

The time and place of service meetings scheduled for the month of May are listed below for the convenience of our readers.

Dubuque, Iowa—May 1, 8:00 P.M.,
Washington Jr. High School.
Sponsor—Boe Distributing Co.

Cedar Rapids, Iowa—May 2, 8:00 P.M.,
Hotel Montrose.
Sponsor—Gifford-Brown, Inc.

Ottumwa, Iowa—May 3, 8:00 P.M.,
Hotel Ottumwa.
Sponsor—Radio Trade Supply Co.,
Ottumwa and Des Moines, Iowa.

Springfield, Mo.—May 4, 8:00 P.M.,
Kentwood Arms Hotel.
Sponsor—Stout's Radio Supply

Wichita, Kansas—May 8, 8:00 P.M.,
Broadview Hotel.
Sponsor—Interstate Distributors, Inc.

Pueblo, Colo.—May 10, 8:00 P.M.,
Minnequa Club, Lake Minnequa.
Sponsor—L. B. Walker Radio Co.

Denver, Colo.—May 11, 8:00 P.M.,
Cosmopolitan Hotel.
Sponsor—Interstate Radio and Supply Co

Cheyenne, Wyo.—May 12, 8:00 P.M.,
Elks Club.
Houge Radio and Supply Co.

New Flange Sign

71 Years of Radio Service



Another new tie-in with Sylvania's national advertising of radio and television service has been announced by the Advertising Department. This new item is an all-metal flange sign made especially for outdoor use. The new sign incorporates the Sylvania decal in full color. The sign is a big 16 inches. It is made of heavy steel, the decal is baked on enamel.

The new flange is now available from Sylvania Distributors or from the Advertising Department, Emporium, Pa. Price of the sign is \$1.25.



To say that Harry's Radio Service, Terre Haute, Ind., represented 71 years of continuous radio service might bring raised eyebrows in some circles. Proof, however, is shown in the above photo. Three generations of one family in the same business is their unique record. Shown left to right in the above

picture is Owen Youngblood, Carl Youngblood, second generation representatives, Harry Youngblood, proprietor and father, and right Lyman Bedwell, third generation representative and Harry's grandson. The three generations operate one of the most successful service businesses in Terre Haute.

How To Explain A "Patch" Job . . .

REPAIR TICKET _____	<i>Service Guarantee</i>
DATE _____	
MAKE OF RADIO _____	
<p>We unconditionally guarantee the parts and tubes used in the repair of your radio and will replace free of charge any part or tube we have replaced if it proves defective within ninety (90) days.</p> <p>We have thoroughly tested the rest of the tubes and parts not replaced and believe they will operate satisfactorily, but are not covered under this guarantee, which only covers parts and tubes replaced.</p> <p>NOTE—This guarantee void if radio is serviced by any other than a certified technician. If your radio does not operate satisfactorily call us at once.</p>	
<p>HODGE RADIO SHOP Est. 1925 CLAREMONT, N. H. PHONE 199</p>	

<p>COMPLETE REPAIR JOB</p> <p>This job consists of a complete overhaul and check of ALL PARTS, tubes, circuits, controls, and replacement of worn or defective parts. Radio will be in new condition and is GUARANTEED FOR THREE MONTHS.</p>	<p>"PATCH-UP" JOB</p> <p>This type repair job consists in replacing or repairing the defective part or tube only so that the radio will operate. NO GUARANTEE IS GIVEN other than the radio will be in operating condition when delivered. (If radio is over one year old, it should have the complete checkup on other side).</p>
---	---

In the February issue of THE NEWS we discussed in a feature article the subject of "patch jobs" and "complete repair jobs." We mentioned the fact that if customers objected to the price for a complete job and only want a job to tide them over, that the serviceman was justified and obligated to make the customer understand that the job did not carry a complete guarantee.

As a result of the story, Mr. V. W. Hodge, Claremont, N. H. has

sent us his method for dealing with this type of work. The form shown above is used when the occasion arises. The tag is attached to one of the shafts where the customer is sure to see it. If he has specified a "patch job" he is reminded that that's just what he got when he gets the set home. If it is, the repair job is a complete overhaul, he is informed of that and is given a guarantee as well.

"We don't have many of the

"patch-up" jobs, as with a little sales talk, we usually get a complete overhaul," says Mr. Hodge. "On the complete overhaul job we give a guarantee form." A sample of this form is shown above. Note that the copy on the form states specifically that the parts and work done are subject to the guarantee. Note also the notice that the guarantee is void if the radio is serviced by other than a certified technician.

"The Four Summer Months Will Be BIG PROFIT MONTHS"

(Continued from page M-13)

Participants in the Sylvania co-ordinated advertising campaign there is a complete kit of promotional material for four months. The kit includes window display material—two large, full-color, three dimensional displays—two matching counter cards, and two window streamers. For use in local papers, there are four newspaper ad mats—two one-column mats and two two-column mats. For reaching the best in radio audiences—the steady radio listener—the kit includes four radio spot announcement booklets. To complete the promotional package, there is a four months supply of distinctive direct-mail

postal cards—one for each month.

To complete the job of promotion, Sylvania runs half page ads in leading magazines every month. These ads are seen and read by more than 15,000,000 people every month. The material in the local kit for dealers ties-in directly with the national ad. Each dealer is identified in the ads and other material by the large RADIO SERVICE or RADIO TELEVISION SERVICE decal which is supplied free to dealers.

The cost of using the campaign in any locality is low. The only cost to the dealer for the complete kit of material is the postage on the

direct mail postal cards which he mails each month to his prospects. All of the material in the kit is furnished free.

If you're planning on a summer slump this year, find out about the Sylvania Coordinated Advertising Campaign. Your own experience will prove to you that there is no such thing as a summer slump.

For more information about this campaign and how it will work to help your own business, write to the Advertising Department, Sylvania Electric Products Inc., Emporium, Pa. Find out how you too can increase your business for only one-cent per prospect per month.



Two full color—three dimensional window displays and two matching counter cards are provided in the big campaign kit.

Summer campaign includes two window streamers for display in store windows. These tie-in with other campaign material.



Each month a new set of radio spot announcements are provided for use over local stations.



Four newspaper ad mats tie-in your shop with the campaign. Ad mats are in one- and two-column sizes—both seven inches.



Complete supply of colorful direct mail postal cards for every prospect. You pay only 1c postage on each card. Imprinted.

Crystal Diode Clippings

J. M. Dietz Wins First Crystal Applications Contest

Winner of the first month's competition in the Crystal Diode Appli-

Haunfelder, Milwaukee 12, Wis.;
F. H. Perkins, New London, Conn.;
P. W. Kuhlman, Dayton, Ohio;
Wade Gass, Bryson City, N. C.;
William W. Ussery, New Orleans,

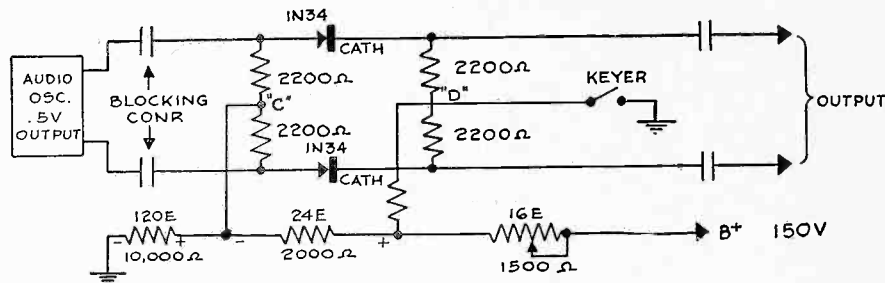

cations Contest, sponsored by SYLVANIA NEWS is Joseph M. Dietz, Purcellville, Va. The application submitted by Mr. Dietz is called an "af diode relay." Development of this application came through the need to key the output of an audio oscillator at a remote point. The device was mounted inside the oscillator cabinet and used the existing power supply.

The circuit operation is as follows:
(1) The audio oscillator is adjusted to the desired frequency with a .5 volt output. (2) Point D is positive with respect to point C. There is approximately 2 volts across each diode holding both non-conductive. Each offers a resistance of approximately 150 K ohms. Audio level at output is better than 75db down. (3) With key closed, point C becomes positive in respect to point D. Voltage now appears across the diodes in the conducting direction. Each diode now offers approximately 150 ohms resistance and a strong signal appears at output.

When conducting, practically the only attenuation to signal is the blocking condensers, since only .05 volt rms is lost through relay itself. The speed of keying limited only by signal frequency.

Other winners in the first month's competition are listed below:

Second prize: John P. Nicolosi,
Brooklyn, N. Y.

Third prize: Earl Mantor,
Chicago, Illinois

Honorable Mention: J. Devilbiss, Manhattan, Kansas; Harry L. Towers, Peekskill, N. Y.; H. O.

La.; C. M. Fuller, Hastings, Nebraska; David T. Armstrong, Weehawken, N. J.; Robert E. Baer, Mount Vernon, N. J.; J. S. Macdonald, Washington, D. C.; R. Berthold, Springfield, N. Y.

Each month there is a new contest. You may submit as many applications as you like, as often as you like. Entries should be sent to the Editor, SYLVANIA NEWS, 1740 Broadway, New York 18, N. Y.

Each month SYLVANIA NEWS will award fifteen prizes for the best applications submitted. First prize is \$15.00 in Sylvania Germanium Diodes of your choice. Second prize is \$10.00 worth of diodes and third prize is \$5.00 in diodes. The next twelve best entries will be awarded two Sylvania 1N34A germanium diodes.

Dealer Association News

ARSNY Graduates First TV Class

The first class of radio and television technicians in a special television training course conducted by the Associated Radio-Television Servicemen of New York, in cooperation with the New York Board of Education, was graduated recently.

A. P. Henry, member of the New York educational system who is in charge of the school said that as a result of the course, 32 ARSNY members have been "upgraded" from the status of "radio mechanic" to that of "television technician" and are now "competent to handle any television servicing job in the radio industry."

Mr. Henry said that the 24-week course demonstrated its value to the radio-television industry and hence "will be continued, but we have great need for additional commercial receivers in order to expand the student program."

Rochester Technicians Protest TV Excise Tax

Voicing protest to the proposed 10% excise tax on television receivers now under consideration in Congress, the Radio Technicians Guild of Rochester, N. Y. have urged every member to write his congressman opposing the tax. The

organization has included the following resolution in their letter of protest:

"Resolved: Inasmuch as we indirectly derive our livelihood from the sale of television receiving sets by servicing them, we feel sure that any increase in the price of these sets, by Federal Excise Tax or other means, will deprive us of part of our income.

"We therefore wish to make a strenuous objection to the proposed 10% Federal Excise Tax on television receivers and parts."

Dallas Association Issues Antenna Regulations

In order to aid television technicians in Dallas, Texas in the proper installation of television antennas, the Dallas Radio Sales and Service Association Inc. have furnished each of its members with a list of regulations for the erection and installation of television antennas.

The rules have been evolved after an investigation of the city ordinances. Although no ordinances have been passed covering this type of installation, the organization is aiding the city officials in setting up such a list of rules. Other groups interested in the regulations suggested by the Dallas organization should contact T. P. Robinson, P. O. Box 2955, Dallas, Tex.

Brooklyn Man Best Guesser



More than 6,000 radio men at the IRE National Radio Show held in New York recently tried to guess the exact number of subminiature tubes in a Sylvania 12½ inch television picture tube bulb. K. R. Brooks of the Navy Department, Brooklyn guessed the

exact number, 1712, and thereby won a Sylvania Polymeter and high voltage probe valued at \$110.00. Three participants guessed 1711 but only fifty ranged between 1700 and 1725. Other guesses ranged from a low of 235 to a high of more than 100,000.

Facts & Figures...

1949 Radio—TV Sales Total
14,500,000 Sets

Sales of radio and television sets in 1949 totaled 14,500,000 according to a joint study of industry statistics made under the direction of the National Association of Broadcasters and the RMA Industry Statistics Committee.

Home radio sets accounted for 7,956,000, automobile radio sets for 3,964,000 and television sets for 2,594,000. Production by manufacturers varied somewhat from these retail sales figures. Industry production figures for the year were set at 3,029,000 television receivers and 7,456,000 home radios.

The report showed the automobile sets in use totaled 14,764,000 which included the 3,964,000 sets that went into 78% of all cars manufactured last year. In addition to automobile sets, the total number of radio sets in the hands of the public at the end of 1949 was 70,436,000.

At the end of 1949, the average number of radio sets, including television, in each American home was 1.7. The ratio of automobile sets to cars, which hit a peak of 88% in 1947 was down to 78% in 1949 although a million more radio sets were produced.

At the beginning of 1950, it was estimated that only 401,000 television sets were in the distributor-dealer pipe-lines. This represents only about one month's production at the present rate.

SYLVANIA NEWS

SYLVANIA ELECTRIC PRODUCTS INC.
P. O. BOX 431
EMPORIUM, PENNA.

Sec. 34.66, P. L. & R.
U. S. POSTAGE
PAID
Permit No. 1
Emporium, Pa.

For:

J. A. Renville
163 Main St.
Luzerne, Pa.

A

POSTMASTER: IF UNDELIVERABLE FOR ANY REASON, NOTIFY SENDER, STATING REASON, ON FORM 3547, POSTAGE FOR WHICH IS GUARANTEED.

Vol. 17, No. 4

APRIL, 1950

PUBLISHED BY
SYLVANIA ELECTRIC PRODUCTS INC.

MANUFACTURERS OF SYLVANIA RADIO TUBES, CATHODE RAY TUBES, ELECTRONIC DEVICES, FLUORESCENT LAMPS, FIXTURES, WIRING DEVICES, ELECTRIC LIGHT BULBS, PHOTOLAMPS, RADIO AND TELEVISION RECEIVERS

In This Issue

NEWS

TOWN MEETINGS FOR
60 TV AREAS

MERCHANDISING

THE FOUR SUMMER MONTHS
WILL BE BIG PROFIT MONTHS

TECHNICAL

TELEVISION SERVICING BY
PICTURE ANALYSIS

SYLVANIA NEWS

MAY 1950 VOL. 17, NO. 5



COPYRIGHT 1950
SYLVANIA ELECTRIC PRODUCTS, INC.
EMPORIUM, PENNA.
BOB PENFIELD, EDITOR

New Sylvania Television Oscilloscope

TYPE 400

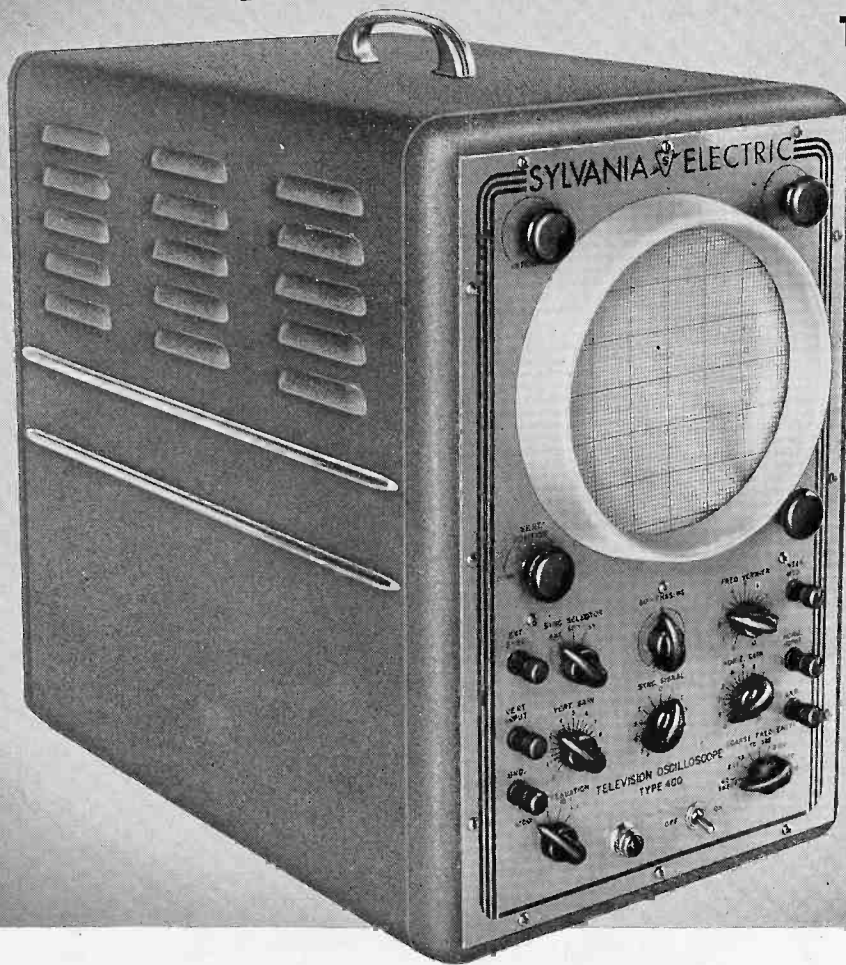

**An exceptionally
high-gain wide
band oscilloscope
designed especi-
ally for television**

Incorporates Many Important Features Found Only In More Expensive Scopes

Another new television test instrument has just been added to the Sylvania line of equipment for servicemen. The new instrument is a high-gain, wide band oscilloscope which has been designed by Sylvania engineers especially for television servicing and other laboratory and industrial applications.

The new oscilloscope, Type 400, which is supplied with a Sylvania 7JP1 green screen cathode ray tube, provides a vertical sensitivity of ten millivolts per inch and a vertical response which is useful up to four megacycles. It accurately displays any TV pulse, wave-shape or signal on the large eye-saving 7-inch screen.

Other features of this new instrument include: Four-position frequency-compensated attenuator for uniform frequency response at any gain setting; vernier gain control; low internal hum level; internal 60 cycle sine wave sweep which eliminates one set of leads during TV alignment operations; wide range phasing control; internal hard

tube sweep circuit; control for synchronizing to either positive or negative signal; good vertical bounce and return characteristics; and rapid return trace.

The oscilloscope Type 400 also provides linear sweeps ranging from 10 cycles to 50 kilocycles; five megohm, 26 micro-microfarad input impedance for negligible circuit loading which is suitable for any crystal, direct or special probe or with supplied lead; cathode follower input circuit; switching for direct connection to deflection plates; panel connection for intensity or Z-axis modulation; built-in 60 cycle voltage source, and low parallax cross lined screen.

Cabinet of the new instrument is pearl grey mar-resistant crackle finish. The panel is light grey with green, baked-on-enamel letters. The instrument is available through authorized Sylvania Distributors. A complete technical discussion of the Sylvania TV Oscilloscope Type 400 will be presented in the June Technical Section of THE NEWS.

TV SWEEP GENERATOR TYPE 500



Ideally suited as a companion instrument for television and FM servicing for the TV Oscilloscope Type 400 is the Sylvania TV Sweep Generator Type 500.

The Sylvania TV-FM Sweep Signal Generator Type 500 furnishes both narrow and wide sweep, both electronically controlled. The instrument provides excellent sweep linearity and consequent distortion-free scope patterns.

All output frequencies of the Sylvania Sweep Generator are provided at fundamental. These frequencies range from 2 to 230 megacycles in four bands which utilize a push-pull variable frequency oscillator.

Complete information is available from Authorized Sylvania Distributors.

SYLVANIA NEWS

Merchandising
Section

MAY 1950 — VOL. 17, NO. 5

COPYRIGHT 1950
SYLVANIA ELECTRIC PRODUCTS, INC.



Sylvania News Eligible for Radio Old Timers

There is usually a great deal of significance attached to a twentieth birthday. It means a crossing over from youth to manhood. It means the shouldering of new responsibilities.

It is with pride that we acknowledge the twentieth anniversary of SYLVANIA NEWS. In one sense, it establishes a record. No other

company magazine in the radio industry has enjoyed so long a life. We are humbled at the respect and interest servicemen, engineers and others have accorded our publication.

To refresh memories, we dug back into the yellowing pages of some of the early issues of THE NEWS. The first issue, published in March 1930

announced that THE NEWS was to be published for the benefit of distributor salesmen. Circulation of the first issue was 3500 copies.

Some of the headlines from the first issue were "Filament and Cap Abuses Explained," "Radio Tube Industry Facing Bright Future," "Tubes Take 22% of Radio Cash."

The success of the first issue was immediate. The second issue carried a story that "Jobbers Demand Sylvania News Go To Dealers." The circulation jumped to 13,000.

Headline story on the second issue was entitled "Lowdown on Pentodes"—a story discussing the design and theory of the pentode. One comment made in the story was that "there is still considerable question as to whether it (the pentode) is actually going to prove a real value in improving radio reception."

One interesting note in the second issue was the story which stated: "A survey made recently by the Radio Record magazine revealed that the average retail value of sets

(Continued on page M-18)

Television and Service featured at Local Meetings

Up to the minute information on television servicing techniques is the feature of Sylvania's continuing program of service meetings being held throughout the country. These meetings are held in cities and towns all over the country to aid service dealers in gaining a better understanding of television servicing. The meetings do not deal with the features of any particular television set.

Feature speaker for these meetings is Clarence L. Simpson, a member of the Commercial Engineering staff of Sylvania. Simpson has had wide experience in radio and television instruction as well as considerable experience in practical servicing of modern television.

A native of Oklahoma, he attended Oklahoma A. & M. College. During the war, he served as a radio and radar instructor for the Army Air Force and as a development engineer for airborne com-



Clarence Simpson, center, answers questions of C. C. Dibrell, Ardmore, Okla. about the Sylvania AM-FM Signal Generator following formal service meeting. Looking on are: J. A. Still, Sylvania representative; J. B. Mooney, (right), Mooney Radio Supply. Meeting was sponsored by Mooney Radio, Wichita Falls, Tex.

munications equipment. Prior to joining the engineering staff of Sylvania, he was associated with the United Television Laboratory, Louisville, Ky.

All meetings in the series are part of a continuing program

sponsored by Sylvania in cooperation with their distributors. Schedules of future meetings appear regularly in the Technical Section. For more information about this information series, see your Sylvania Distributor.

Sylvania News Eligible for Old Timers

(Continued from page M-17)

sold in 1929 was \$139.78. This figure does not include tubes."

In May 1935 the Technical Section of THE NEWS was added. Previously, technical data was included as a part of the editorial material.

Circulation of THE NEWS has grown constantly throughout the years. This growth is indicative of the growth of the service industry as well as the acceptance of THE NEWS as an important factor in the life of the service dealer. This issue of THE NEWS will be mailed to nearly 90,000 readers in this country and abroad.

SYLVANIA NEWS is published for the radio service industry. As in the past, we will continue to bring the latest technical, merchandising information and news of the industry to our readers. It is our aim to aid the service dealer in performing his job more efficiently.

M-18



Interest in Sylvania Test equipment is shown by Warren Radio personnel at recent Akron, Ohio service meeting. Bruce McEvoy, Sylvania division manager points out advantages of new tube tester in checking tubes accurately to Warren Radio Men. Meeting was attended by more than 200 servicemen from the Akron area.

SYLVANIA NEWS

SYLVANIA NEWS

MAY 1950

Copyright 1950
Sylvania Electric Products Inc.

VOL. 17, NO. 5

TECHNICAL
SECTION

The information in Sylvania News is furnished without assuming any obligations.

Technical Editor A. V. BALDWIN

TELEVISION SERVICING by PICTURE ANALYSIS-III

By C. Masucci and W. B. Whalley

Photographs by L. Ankersen

The seventeenth article of a series on television by Sylvania engineers. Parts I and II of "Television Servicing by Picture Analysis" appeared in the January and April issues of Sylvania News.

Modern television receiver servicing improves as the serviceman becomes better acquainted with the operation of the many different types of circuits used in such receivers. The photographs of the distorted test patterns presented in this article are intended to point out how some of the many causes of defective operation may be quickly located in a particular section of the receiver. It sometimes takes a detailed and painstaking search to find the reason for the trouble after it has been localized. However, much preliminary work can be accomplished by this method.

Characteristic types of picture distortion are associated with the

different sections of the receiver. For instance, deflection circuit defects generally affect shape and size, while video circuit defects generally affect brightness and contrast.

This is well illustrated by the effects of hum. In the video circuits hum will black out part of the picture as shown in the photograph below. In the deflection circuits, hum will affect shape and size, but not brightness. If the hum is in the horizontal portion of the deflection circuits, the sides of the picture will be S-shaped. In the vertical deflection circuits it will result in loss of interlace and some vertical non-linearity. When hum is present in two or more sections, multiple effects will appear in the picture. A knowledge of these characteristic effects associated with defective operation of the main sections of the television circuit will help immeasurably in the

preliminary analysis of any receiver.

Specialized test equipment is invaluable in the subsequent work of searching the circuit for the cause of defective operation. Because the voltage waveforms in the various circuits follow definite patterns, an oscilloscope is most useful in the efficient servicing of television receivers.

Also, an oscilloscope can be used in conjunction with a sweep signal generator to visually observe the response pattern of video i-f and r-f circuits. A marker generator is used to place "pips" in the curve to help in its correct adjustment. A vacuumtube voltmeter is also of great help in the measurement of voltages without disturbing the various circuits. With the aid of special high-voltage probes it is possible to measure d-c voltages up to as high as 30,000 volts with accuracy and safety.

The photographs illustrate the results of defective operation of television receivers and do not in any way reflect upon the quality of transmission of any television station. They are presented with the permission of WPIX and WOR-TV.

CONDITION:—Dark areas across top and bottom of picture.
CAUSE:—Hum (60 cycles) in the video amplifier picked up from filament leads or from the power supply transformer.

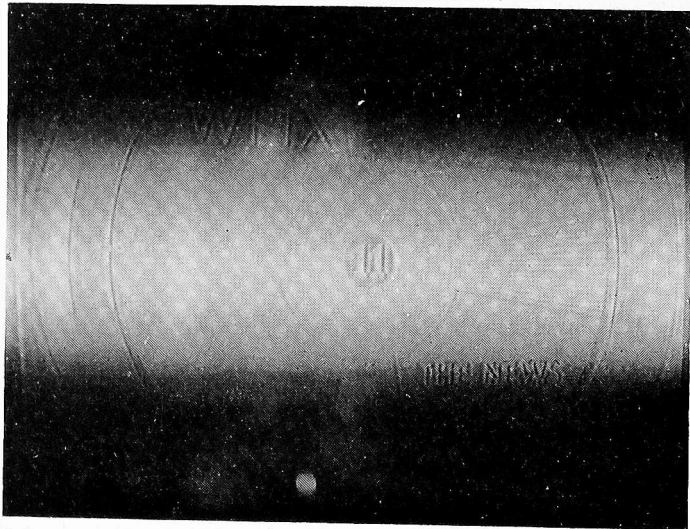

CONDITION:—The picture is out of focus. CAUSE:—(A) The focus control is out of adjustment. (B) The focus coil is shorted or out of adjustment.

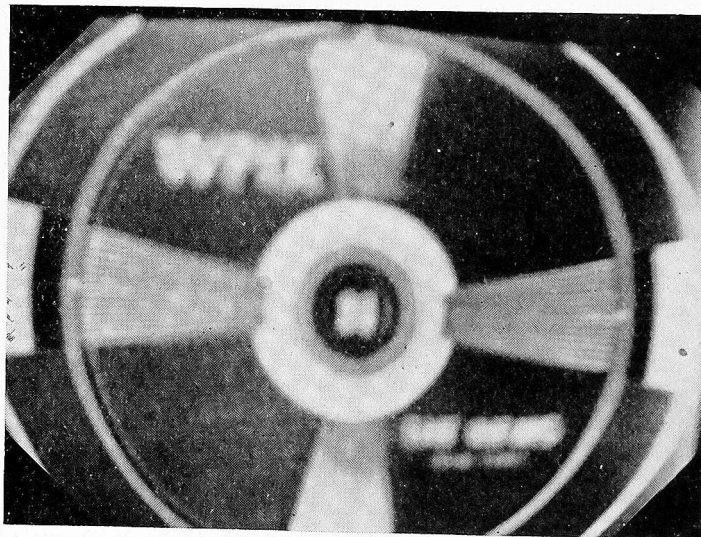

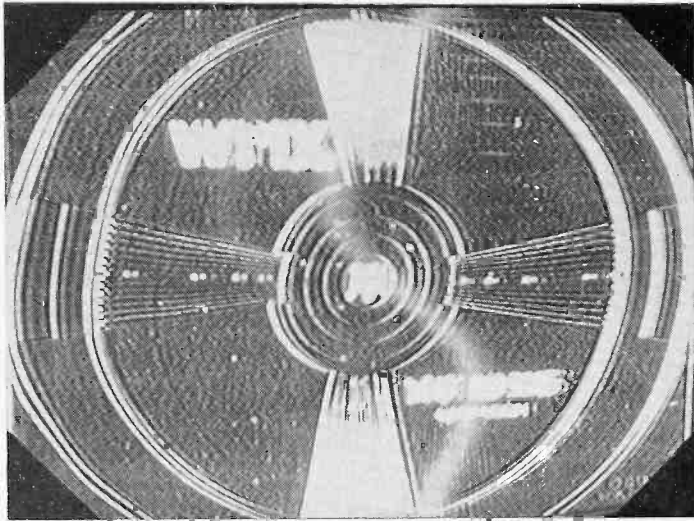

CONDITION:—Negative pattern. CAUSE:—(A) Contrast control is set too high. (B) Shorted condenser in the AGC line.

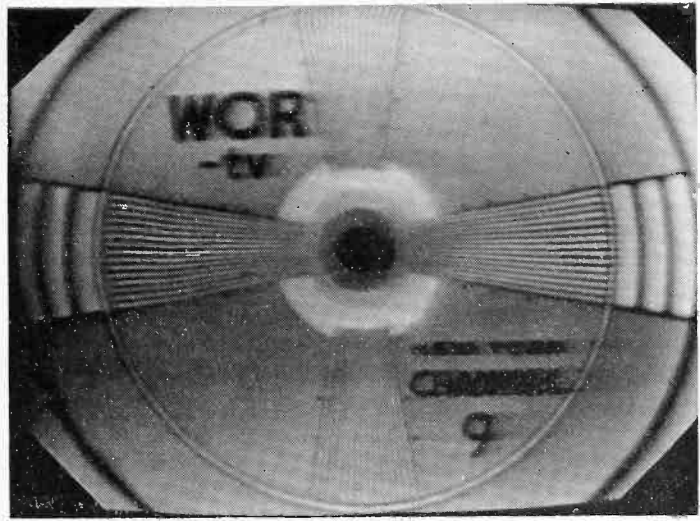

CONDITION:—The pattern is smeared and the vertical wedges have poor resolution. CAUSE:—Shorted peaking coils in both the grid and plate circuits of the video amplifier.



CONDITION:—Poor resolution of vertical wedges and the retrace lines are visible (low gain). CAUSE:—Load resistance of the video amplifier is increased due to the opening of a plate peaking coil which was shunted by a resistor.

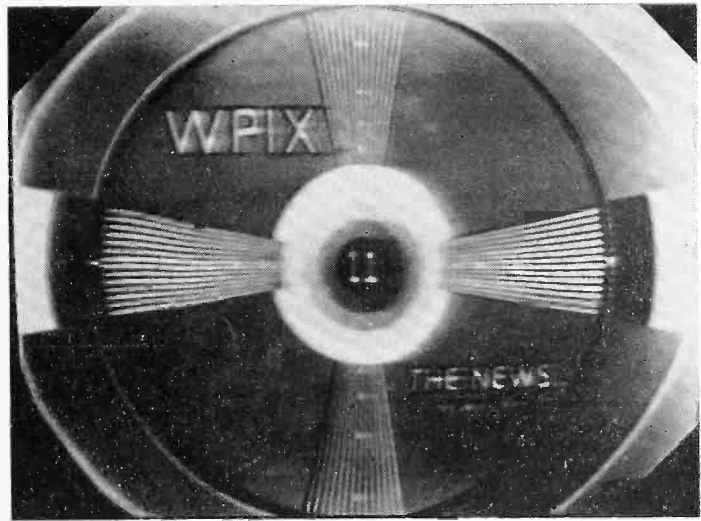

CONDITION:—Pattern is smeared and indistinct. CAUSE:—Capacitance across picture tube grid or cathode to ground, depending on which element is driven. Dress leads in video amplifier circuits and the video lead to the picture tube.

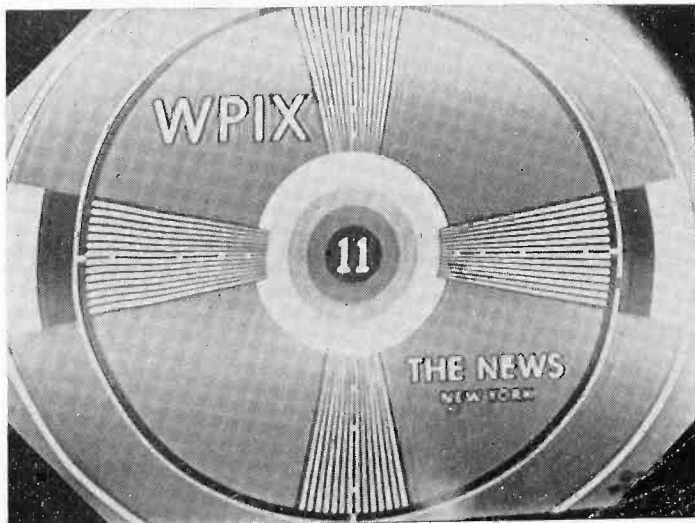

CONDITION:—Two horizontal dark areas and two horizontal light areas across the picture. CAUSE:—Poor filtering of the plate voltage in the video amplifier, causing injection of 120--cycle ripple voltage into the video signal.



CONDITION:—Poor resolution of the vertical wedges and visible retrace lines (low gain). Trailing white edge in picture. CAUSE:—Use of remote cutoff pentode (6BA6) in i-f strip designed for sharp cutoff pentode (6AG5).

Revised Test Settings for Sylvania Tube Testers

NEW CHART AVAILABLE FOR TYPES 139 AND 140

The first revision in the test settings for the Sylvania Type 219 and 220 Tube Tester are shown in the accompanying table. Also shown are several revisions in the settings for the Types 139 and 140 Tube Testers which have been made since the last announcement in SYLVANIA News in January 1950. This listing

should be posted near your tester so that you will be able to keep up to date in tube testing requirements.

A new chart for Types 139 and 140 Tube Testers is ready for distribution. It contains all of the revisions and additions, including those in this issue, made since the issuance of the last chart. For your information the charts on all

Sylvania tube testers may be identified by a number in the lower left hand corner. The number of the new chart for Types 139 and 140 is 15845-E and the number of the last one is 15845-D.

The chart may be ordered from the Advertising Department, Sylvania Electric Products Inc., Emporium, Pa. The price is \$1.00 postpaid.

Types 219 and 220 Tube Testers

Chart A — Revision I

TYPE	A	B	C	D	E	F	G	K
1AF4	1.4	7	15S	32	4	036U	2	—
	1.4	7	15S	32	5	036U	2	—
1AF5	1.4	7	1	53	1	046T	5	—
	1.4	7	1	47	1	T	3	—
1B3GT	1.25	2	13578	21	7	U	9	—
1LE3	1.4	1	58	67	8	6V	2	—
1LG5	1.4	1	58	43	8	036T	2	—
1R4	1.4	1	28	39	8	T	4	7
1U6	1.4	1	7	27	7	056U	2	—
	1.4	1	7	37	7	45U	3	—
1V2	0.65	4	5	33	5	U	9	—
2V3G	2.5	2	7	19	7	U	9	—
3E5	2.5	1	57S	35	7	036V	2	—
6C4	6.3	3	245	36	4	6Z	1	7
6BQ6GT	6.3	2	7	13	7	045Z	9	8
6V7G	6.3	2	7	30	7	0Y	3	8
	6.3	2	7	40	7	T	4	8
	6.3	2	7	40	7	T	5	8
7B6	6.3	1	48S	49	8	3T	2	7
	6.3	1	48	41	8	T	5	7
	6.3	1	48	41	8	T	6	7
7C4/1203A	6.3	1	28	36	8	T	4	7
7C6	6.3	1	48	38	8	3T	2	7

12AL5	12.6	3	4	22	4	X	2	5
	12.6	3	4	32	4	X	7	1
12AY7	12.6	4	59	45	5	2Y	1	3
	12.6	4	59	45	5	7Y	6	8
12BK6	12.6	3	4S	25	4	1U	7	2
25W4	25.0	7	18	10	8	Z	5	3
25BQ6GT	25.0	2	7	13	7	045Z	9	8
45Z3	50.0	1	367	11	7	Z	2	4
V99	3.3	2	4	15	4	1U	3	—
X99	Delete Type V99							
815								
Left Cap	12.6	1	58	26	8	047Z	9	6
Right Cap	12.6	1	58	25	8	24Z	9	3
9001	6.3	3	24S	70	4	16Y	5	7
	6.3	3	47S	70	4	16Y	5	2
9003	6.3	3	47	40	4	16Y	5	2
	6.3	3	42	40	4	16Y	5	7

Types 139 and 140 Tube Testers

Chart D Revisions

TYPE	A	B	C	D	E	F	G	Test
3V4	2.5	2	5	4	1	016	45	U
6A8	6.3	0	—	0	1	039	81	W
	6.3	0	—	0	5	4	47	V
6BC5	6.3	0	4	0	4	36	70	T
12AY7	12.6	0	5	0	1	3	56	W
	12.6	0	5	0	3	7	56	W

Sylvania Engineers Develop Instrument for Measuring Picture Tube Color Response

A new instrument for automatically measuring and recording the color response of a television picture tube screen has been developed by Sylvania engineers in the Bayside Physics Laboratories. This instrument, known as an automatic recording spectroradiometer, gives an argument-proof check of image color of television picture tubes in 48 seconds, directly on a paper-chart recorder.

As in other new and expanding fields, the specifications and methods of measurement of television systems have not yet caught up with the use of the art. It has happened that customers have rejected picture tubes because they were not pleased with the color of the picture. Even though the customers may have

been right, the important thing is that there is no method of measuring the quality of the screen color now accepted by the television industry as a group.

This lack of standardization is well recognized. The Joint Electron Tube Engineering Council (JETEC) and the National Bureau of Standards, as well as a number of commercial laboratories, are working vigorously to achieve a standardization for the color quality of picture tubes.

The new recording spectroradiometer developed by Sylvania is a step in the direction of such standardization. A full description of its operation was published in the February 1950 issue of Electronics.

FREE TUBE TESTER

Charts for Types 219 and 220

New charts for the Type 219 and 220 Tube Testers will be sent to owners for a full year after the Tester is purchased. The introduction of new tubes and the changes necessary in the testing conditions of older tubes makes it desirable to use an up-to-date chart for the efficient checking of tubes in the service shop. To be eligible to receive the new chart it is necessary that the purchaser send the warranty card for the Tube Tester to Sylvania at the time of purchase.

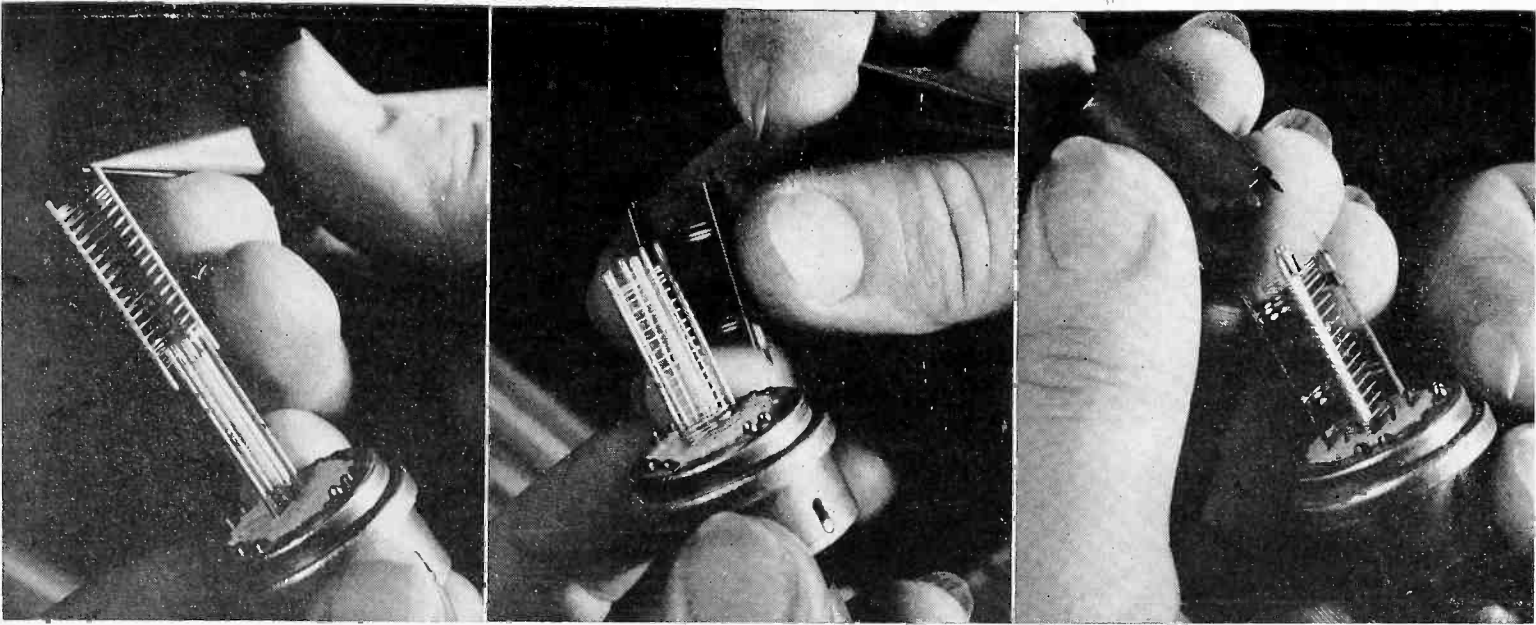

SKILLED HANDS AND SHARP EYES work together in the assembly of a Sylvania miniature receiving tube. The utmost care is necessary in this stage of the processing to ensure that the tubes will give long, uninterrupted service to the customer.

The mount assembly shown here is for a miniature r-f pentode. From left to right are shown the

suppressor grid, the plate, and the shield being placed in position. The cathode in the center, the control grid, the screen grid, and the bottom mica had previously been assembled on the mounting jig. After all the elements are in place, a second mica is placed over the top and the plate and shield tabs extending through the mica are bent over.

At various stages of the assembly operation the parts are inspected with a magnifying glass to make certain of correct fit and that the parts remain undamaged. The complete mount assembly is later spot welded to the lead wires of the stem which forms the base of the tube. This is but one of the many steps in the manufacture of Sylvania radio and television tubes.

SERVICE HINTS

Tube Replacement In English Sets G.E.C. Model BC4172 ETC.: We have found that many English sets using the Marconi/Osram type Y64-63 will work just as well with the Sylvania type 6U5. They last longer and the lower list price is an added inducement unless the set owner insists on original replacement.—A. S. Balaganesan, Trichinopoly, India.

* * *

Zenith Model 4G800: Severe distortion and low volume in this model has been traced to a low screen grid voltage on the 1S5 tube. The 4.7 meg screen grid resistor seems to increase in value.—Andrew Ordog, Jr., Madison, Wisconsin.

* * *

GE-F63 Howl After Replacing Output Transformer: This set uses degenerative feedback and it may therefore be necessary to reverse the connections to the secondary of the output transformer. The howl is from audio regeneration and would be very puzzling to servicemen who have not realized that the polarity is critical.—Clifton S. Krumling, Brewster, Minnesota.

RCA 8BX5 (AC-DC): I have found that the tendency of the tubes in the output section to appear microphonic can be corrected by replacing the 0.002 coupling condenser with a 0.01 or 0.02. This also improves the tone and makes it unnecessary to select tubes in an effort to find one which sounds all right.—Southside Appliance Co., Petersburg, Virginia.

* * *

Philco-Dodge C4608: Several of these radios had the same trouble, vibrators failed, in less than a year. One owner had the radio back to the auto dealer the car was purchased from and they evidently put in new vibrator, as ticket attached stated "vibrator." However, if they had removed the bottom cover and looked they would have found the buffer condenser attached at only one end, the other end floating, touching pin 6 of 7Y4 and ground but never wrapped around lug and soldered. When vibrators fail why don't servicemen look for other trouble?—David V. Chambers, Upper Darby, Penna.

TELEVISION AND FM REACTANCE CHARTS

Reactance charts covering the frequency range from 10 to 50 megacycles and from 50 to 250 megacycles were recently published in the Sylvania Engineering Newsletter No. 93. Inductance, capacitance, reactance, and frequency have been plotted so that a straight line connecting any two known quantities in the nomograph will determine the others.

The charts include the intermediate frequencies and radio frequencies of both television and fm. The limited range covered permits a quick solution to most practical reactance problems with a high degree of accuracy.

Three other reactance charts covering the frequency range from one cycle to 1000 megacycles are also included. Thus, all frequencies in the audio and radio ranges up to the ultra-high frequencies are covered.

A free copy of the Engineering Newsletter may be had by sending a postcard to the Advertising Department, Sylvania Electric Products Inc., Emporium, Pa.

SYLVANIA NEWS



Paging More Service Business

Consistent advertising and promotion by radio service dealers is recognized as the best method for assuring steady business and bigger profits. Much of the material for use by service dealers is furnished by Sylvania at modest cost.

Many dealers develop their own methods of promotion which utilize the material supplied by Sylvania in addition to specially tailored advertising for their own locality.

One good example of a service dealer who takes advantage of Sylvania's large promotion campaign to help increase the effectiveness of his own local advertising is Platten Radio Co., Green Bay, Wisc. A large part of Platten Radio's advertising appropriation is spent on billboard advertising.

Strategically located billboards in any locality are effective advertising. Platten Radio backs this story with proof of their own business. The three servicemen employed in this shop are proof of the results obtained from this type of advertising.

The present billboards used by Platten Radio are three feet by six feet and utilize the new day-glow fluorescent type paint. In addition to a message about their service, Platten Radio uses a nationally

advertised Sylvania RADIO SERVICE decal to tie-in their business with the radio service dealer talked about in Sylvania advertising. Use of this decal identifies them as the top-flight technicians talked about in these ads and helps increase their business.

To insure quality in their service work, Platten Radio use Sylvania tubes 100% because they offer dependable service and assure customer satisfaction.

Our Face Is Red!

On page 91 of Sylvania's new book "Servicing TV Receivers" the alignment responsive curves are incorrectly placed. To correct this mistake, a handy sticker showing the correct placement of the curves has been printed. If you now have a copy of the book which does not include the sticker, the corrected version of this page will be mailed to you if you send a card or letter to the Advertising Department, Sylvania Electric Products Inc., Emporium, Pa. Servicemen would experience great difficulty if they were to use the curves as they appear in the book. There is no charge for the sticker.

Service Banner Makes Billboard

The new Sylvania service banner is one inexpensive way to make your own outdoor billboard. This big 48-inch by 28-inch banner is an all-weather sign for indoor or outdoor use. Heavy metal grommets help hold it securely. It is printed in three bright colors. Price, 40c each or 3 for \$1.00. Order from your Sylvania distributor, or from the Advertising Department, Emporium, Pa.

In India . . . Sylvania Builds Business

Got Your Copy?

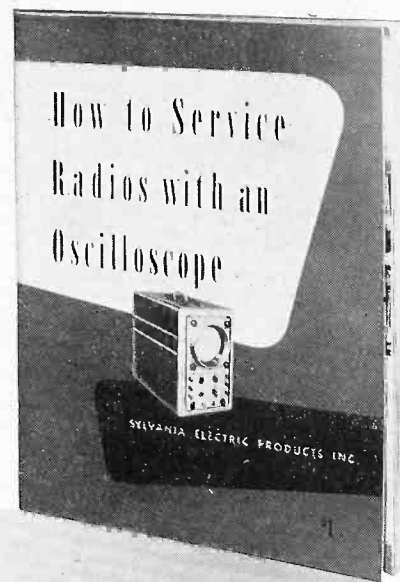

Sylvania's coordinated advertising campaign not only builds business for service dealers in this country, but is used in many other countries by aggressive service dealers. Shown above is the shop of Southern Wireless Services, Tiruchirapalli,

India. Dominating the picture is Sylvania advertising material. This material plays an important part in increasing the business of this shop. A. S. Baladanesan, proprietor of the shop is sitting. Standing is K. M. Krishnan.

Dealers and technicians everywhere are acclaiming the Sylvania book "How To Service Radios with an Oscilloscope." To make your work easier get your copy now. Order from your Sylvania distributor or from the Advertising Dept., Emporium, Pa. The price is \$1.00 postpaid.

It's Spring!

Spring is a time when we all begin to think of new things. New clothes, new flowers, new trees, new surroundings. Cool breezes, blossoming trees, and the smell of freshly turned earth inspire us to do great things. When we open the door on the first warm day, the balmy breezes feel warm and inspiring. The dust that blows out from beneath counters and benches make us realize that a good house-cleaning would do a lot for the morale.

The clean smell of fresh paint, and a newly polished floor will always lift morale and life won't seem half so tough. Your friends and customers will also be impressed. It's always a pleasure to do business in a fresh looking place.

Clean windows and new window displays will make your shop more attractive—a better place to work—a new invitation for more business. People are beginning to shop around. Eye-appealing shops are sure-fire medicine for stimulating them to do business in your store.

Ohio Dealers Visit TV Tube Plant



Visitors at Sylvania's Ottawa, Ohio Television Picture Tube plant recently included a group of service dealers from Columbus, Ohio. The trip was sponsored by Electronic Supply Corp., Sylvania Distributor in Columbus, to acquaint dealers with picture tube manufacture. Plant manager Bill Toner played

host to the group. Above is shot of those making the trip taken before they left Columbus for Ottawa. Sylvania's Ottawa plant is one of two plants whose production is devoted exclusively to manufacture of Sylvania television picture tubes.

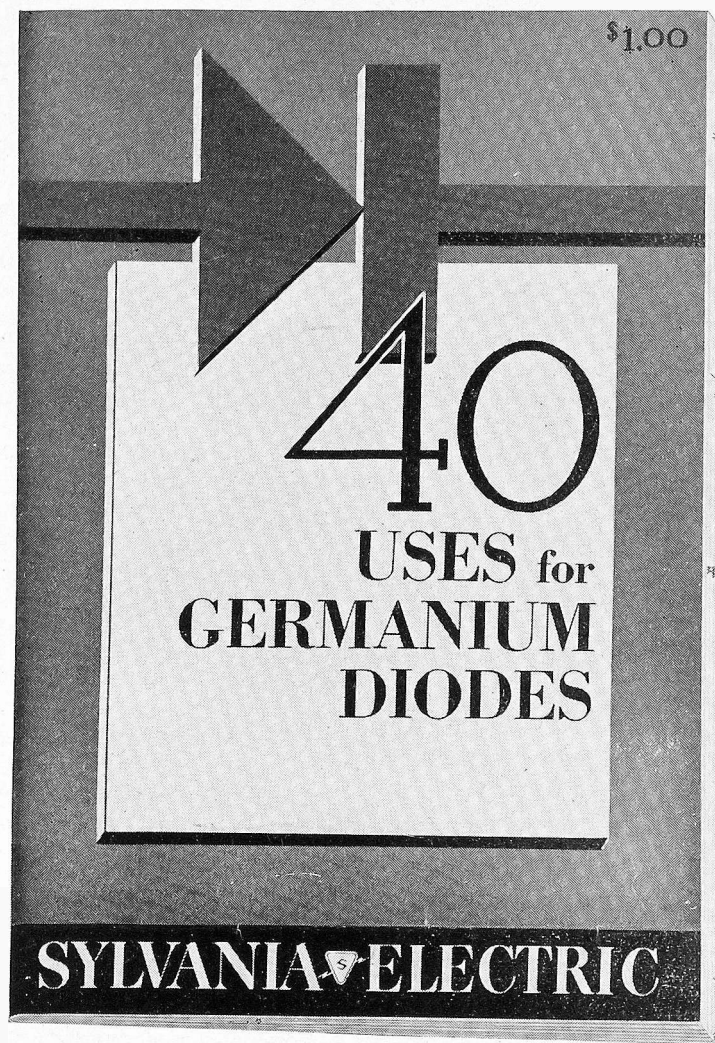

New Book Tells Many Uses For Germanium Diodes

A new booklet, profusely illustrated with typical circuits for forty basic germanium diode applications has been published by the Electronics Division of Sylvania.

Text of the booklet is grouped in three sections which describe germanium diode applications in radio and television receivers; radio transmitters and amplifiers; and a wide range of instruments and supervisory circuit devices.

The first section on crystal radio receivers and video circuit components contains 10 schematic diagrams with circuit constants. The second section on transmitters, which will be of particular interest to radio amateurs and others who maintain mobile equipments, includes six schematics. The section treating instrument and gadget uses describes twenty-four devices ranging from a simple sideband generator in which matched diodes are arranged as a ring modulator to a 144 mc tubeless radio receiver for the remote control of model airplanes and model boats.

The booklet also includes adequate descriptions and circuit diagrams for many easy-to-build devices for the modelmaker and experimenter including crystal voltage multipliers, two way relays operating at different dc voltages and suitable for temperature, frequency and currency variation measurement, or for relay operation of alarm or recording mechanisms; frequency triplers; tubeless tone generators; and selective telephone and telegraph circuits.

The "40 Uses for Germanium Diodes" booklet, which measures 6" x 9" also contains ratings and characteristics of available Sylvania Germanium Crystal Diodes. It may be obtained from Authorized Sylvania Distributors or from Advertising Department, Emporium, Pa. Price of the booklet is \$1.00.

Crystal Diode Clippings

—by Robert C. Moses—

Congratulations this month go to Mr. Remsen T. Schenk, of Bangor, Pa. for his first-prize winning contribution to the Sylvania News Crystal Diode Application Contest. The application submitted by Mr. Schenk outlines an improvement on a cascade triode square-wave shaper circuit originally described in *Science Magazine* for September 1941.

This device is designed for use with any audio oscillator capable of delivering 20 volts r.m.s. or more into a 10,000 ohm load impedance, and provides up to 50 volts of square wave over a frequency range of 20 to 20,000 cycles per second.

MAY 1950

Mr. Schenk's modified circuit uses four Sylvania 1N34 crystal diodes as clipper elements, one 1N34 crystal diode as a bias rectifier, and two type 7N7 dual triodes as square wave amplifiers. The circuit provides a square wave rate of rise of less than 10 microseconds, with a waveform top flatness of better than 2%. Having but two tubes, the unit becomes a very compact assembly of modest power requirements.

The basic principle of operation is that of successive amplification and clipping. Because this is carried out in four cascaded stages, the rise rate and squareness of the final

output waveform is more than adequate for all ordinary measurements throughout the audio frequency range.

The operation of the circuit is as follows: An input signal of about 20 volts r.m.s. amplitude is applied to the cathode of crystal diode CR-1 through a large series resistance*. The crystal is provided with a negative bias of approximately 8 volts on its anode, thus it is cut off until the peak of the input signal reaches this level. Above this point, the diode becomes conductive and sharply clips off the negative peaks

(Continued on page G-20)

**EDITOR'S NOTE: The frequency range of the shaper described may be extended somewhat by reducing the values of the resistors at the grids of the triode amplifiers. Changing the 2 megohm resistors specified to 100,000 ohms will permit operation up to about 50,000 cycles per second.*

Crystal Diode Clippings

(Continued from page G-19)

of the applied signal. This partially clipped waveform is then applied to the input of the first triode amplifier stage. This stage amplifies and inverts the signal impressed on its grid.

The inverted, amplified, and partially clipped waveform at the plate of the first triode is applied to the second clipper diode CR-2, which again clips the negative peaks in the same manner as the first diode. The signal is now clipped in both directions, and appears at the plate of the second triode as a nearly square wave.

Clipper diodes CR-3 and CR-4, together with the two sections of the second tube function in exactly the same manner as the first two stages of the shaper, and serve to supplement the squaring action.

Bucking bias for the anodes of the clipper diodes is provided by a fifth 1N34 connected as a peak rectifier across the 6.3 volt heater supply. Because very little current is drawn from this supply, only a small

amount of filtering is required.

Second and third prize winners are:
Second Prize: John P. Nicolosi, Brooklyn, N. Y.

Third Prize: Arley L. Tripp, San Francisco, Calif.

Those receiving honorable mention will be notified by mail.

Each month SYLVANIA NEWS sponsors a new contest for applications of Germanium Diodes. Winners in each month's contest are awarded Sylvania Germanium Diodes as follows: first prize of \$15, second prize \$10, third prize \$5; the next twelve applications receive two Sylvania 1N34A diodes. Enter as often as you like. Send your entry to the Editor, SYLVANIA NEWS, 1740 Broadway, New York 19, N. Y.

EDITOR'S NOTE: Because of space limitations we have omitted the circuit diagram of R. T. Schenck's square wave shaper. Any reader interested in securing a copy of the circuit used in this application may obtain it by writing a card or letter to the Editor, Sylvania News, 1740 Broadway, New York 19, N. Y. The diagram will be supplied free.

Facts & Figures...

TV Production Sets Quarterly Record

Production of television receivers during the first quarter of 1950 was 21% higher than in the previous peak period in the last quarter of 1949. First quarter production was also more than three times the output of television sets in the first quarter of 1949 according to the RMA.

RMA member - companies produced 1,227,930 television receivers in the quarter compared with 1,011,057 in the fourth quarter of 1949 and 422,537 in the first quarter of 1949. Total industry output in the first quarter of this year was estimated at 1,600,000.

Production of radio sets during the first quarter of 1950 was 1,724,660 including 273,732 FM and AM-FM sets. FM facilities were also included in 134,629 television receivers.

TV Tax Rejected

The House of Representatives Ways and Means Committee have rejected the proposal of the Secretary of Treasury for a 10% excise tax on Television receivers. While the committee is not expected to reverse its decision, further action on the entire measure is necessary before the bill is presented to the House. The TV tax, moreover, could be voted as an amendment in the House and the Treasury proposal will be further considered by the Senate Finance committee when the legislation leaves the House.

In This Issue

NEWS

NEW SYLVANIA TV
OSCILLOSCOPE

MERCHANDISING

SYLVANIA NEWS ELIGIBLE
FOR RADIO OLD TIMERS

TECHNICAL

TELEVISION SERVICING BY
PICTURE ANALYSIS

SYLVANIA NEWS

SYLVANIA ELECTRIC PRODUCTS INC.
P. O. BOX 431
EMPORIUM, PENNA.

Sec. 34.66, P. L. & R.
U. S. POSTAGE
PAID
Permit No. 1
Emporium, Pa.

For:

J. A. Renville
163 Main St.
Luzerne, Pa.

POSTMASTER: IF UNDELIVERABLE FOR ANY REASON, NOTIFY SENDER,
STATING REASON, ON FORM 3547, POSTAGE FOR WHICH IS GUARANTEED.

Vol. 17, No. 5

MAY, 1950

PUBLISHED BY
SYLVANIA ELECTRIC PRODUCTS INC.

MANUFACTURERS OF SYLVANIA RADIO TUBES, CATHODE RAY TUBES, ELECTRONIC
DEVICES, FLUORESCENT LAMPS, FIXTURES, WIRING DEVICES, ELECTRIC
LIGHT BULBS, PHOTOLAMPS, RADIO AND TELEVISION RECEIVERS

SYLVANIA NEWS

BOB PENFIELD, Editor

JUNE-JULY 1950

VOL. 17, NO. 6

Copyright 1950, Sylvania Electric Products Inc.

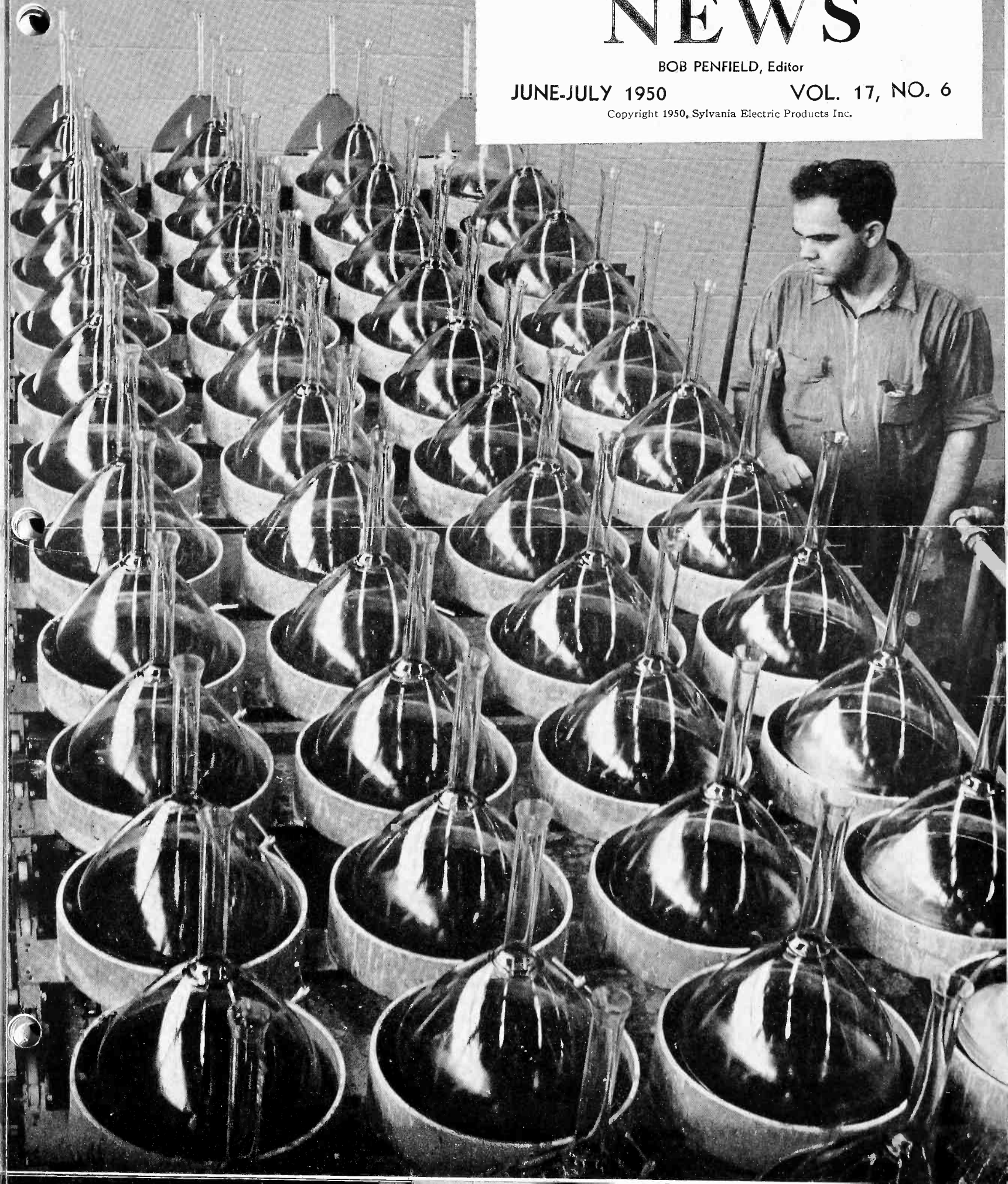

A Tip On The Stock Market

By Arthur Silverberg

Vice President, ARTSNY

Do you read the stock market reports? Have you noticed what is happening in radio and TV? Yessir, TV is on the band-wagon.

What's your stock worth these days? You say you don't dabble in stocks? Oh yes you do, brother. You've got radio stock and you've got TV stock, in fact you've invested up to the hilt in them.

There are men who have no business or profession, except that of buying and selling shares in prosperous industries. They are making a lot of money right now in the radio business. Are you?

Your shares consist of your technical knowledge, your merchandise, and your customer good-will. They are all under your control, and they don't change with every whim of the speculators. Your shares are long-pull shares, slowly but definitely increasing in value, as you make them. You won't collect as much as the stock market gamblers, but you won't lose as much, either. Your roots are in deep, clean soil.

What about your customer good-will? Is it something that gives you a warm feeling, or don't you ever think about it? Brother, it's the one thing that no one can take away from you, and no one can give you. Build it up carefully, with honest, conscientious attention and it can carry you to the heights. Neglect it for a moment and it can destroy you. All your money won't buy you the advertising space that a satisfied customer can put in a few words of recommendation.

You say you're too busy to be idealistic? Okay, but read this over again, and, if you think that giving a customer a good deal so that he will tell his friends that you are a good guy and a good mechanic is idealism, then one of us should get out of the radio business and I'm staying in.

Licensing Threatens New York Television Technicians

Licensing is again threatening the radio and television technicians of New York City. Latest cause of the new move is the result of a survey made by Radio Daily, trade publication of the radio and TV industry.

Published early in May, the results of the survey made by a technician for Radio Daily showed that several service contractors in the New York area were giving poor and inefficient service to TV set owners.

Following publication of the story, a bill was introduced in the New York City Council calling for licensing television service men. Some

of the requirements for licensing and restrictions placed on servicemen by the bill included:

1. A statement of financial responsibility showing that the contractor or service organization is solvent.

2. A list of a minimum amount of testing equipment to be available in every shop for testing and servicing receivers.

3. A stipulation that the service bench area include a minimum of 30 square feet of work area.

4. Minimum requirements for store size of 500 square feet and a list of hours during which a shop must be open for business.

5. A requirement that each licensed service organization employ at least three people.

6. A stipulation that all service organizations carry a contractor's liability insurance of \$5,000 — \$10,000.

The fee for licensing a service organization for television service is specified at \$500 for the first year and an additional \$50 for each year the license is renewed. The bill also sets additional fees required for filing for the license and issuance of a certificate of financial responsibility.

Action against the bill has been taken by the Associated Radio-Television Servicemen's Association of New York. The organization has branded the bill as discriminatory and ineffectual. The organization registered their protest of the bill at a mass meeting. The nearly 1200 servicemen who attended the meeting sent cards and letters voicing their objections to city council members and a complete transcript of the speeches and the discussion has been sent to the legislative body.

President of ARTSNY, Max Liebowitz, speaking for the organization said, "We are not opposed to a regulatory state law which would curb the undesirables in the service field. However, we are against the enactment of a local law which would make enforcement of the regulation a political football."

Liebowitz expressed little surprise at the results of the Radio Daily investigation. The number of people victimized by unscrupulous servicemen would run into thousands and the situation has been getting worse for over a year, according to Liebowitz. He placed part of the blame for the servicing malpractices on the cut rate dealers who use the service contract in making up profit.

A move has been made by the Better Business Bureau of New York to set up an organization for handling service complaints. The BBB hopes that the organization will help to police the industry to curtail the activities of dishonest service dealers.

Other groups voicing protest to the proposed licensing law are the RMA Service Committee, John F. Rider, publisher, the National Electronic Distributors Association, and the American Legion.

How to DEVELOP and KEEP Regular Customers

Like most service dealers, you probably spend considerable time and money in an effort to attract new customers to your store. Do you give equal attention to holding them once they have started to do business with you?

Obviously, aggressive servicemen are continually trying to attract new customers. However, many times they are inclined to take old customers for granted and in doing so tend to lose their business. An old, regular patron is the most profitable type of customer. He can create new sales by his word-of-mouth advertising of your business.

Here are a few suggestions which may be of help if you have been losing older customers or have failed to make regular customers out of newcomers. An analysis of some of these causes of customer dissatisfaction may help in determining reasons for loss of business or for improving present facilities.

Here's a list of questions which will help decide how your business stacks up against the general wishes of the public in their search for the right place to shop.



Make Customers feel at home in your shop.

1. Do you make a genuine effort to satisfy every customer? Indifference to customer demands will usually send him to some other place to shop... especially when he is buying service.

2. Are customers made to feel at home in your shop? Do you know each person's name and how do you show you appreciate their patronage?

3. When you get a call for service, do you attempt to get all the information you can about the job? By the same token, do you give the customer all of the information you can about what you did to his set and why it was necessary for you to do it.

4. Do you carry standard brands of merchandise? Known merchandise is always easier to sell and satisfy customers than distressed merchandise and unknown brands.

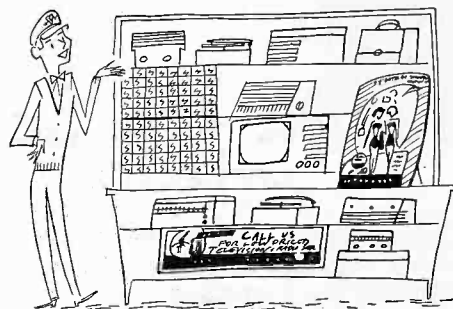

Display Merchandise attractively.

5. Is your merchandise kept clean? Dirty merchandise indicates lack of confidence in your shop and your service.

6. Do you display merchandise attractively. Attractive merchandise displays show your customers that you have faith in the merchandise which you sell.

7. Do you keep an "out of stock" book which shows material needed but not in stock. This eliminates delays in service jobs and saves time in ordering from your distributor.

8. Are your window displays interesting and attractive? Eye appealing window displays stimulate customer interest. They are good

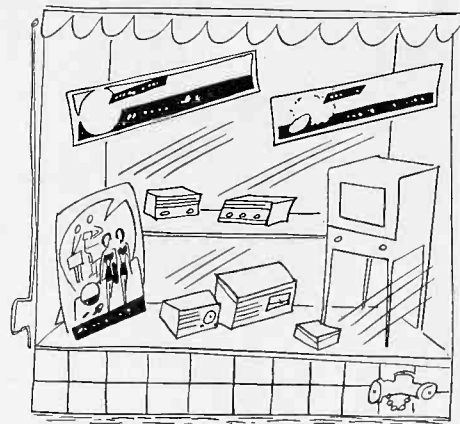

Make Interesting and attractive window displays

salesmen which never stop working for you.

9. Is your advertising always factual and truthful? Honest representation of your service business is just as valuable to you as the type of job you do when you repair a customers set.

10. Are promises to customers kept? When a customer is promised a set at a certain time, prompt delivery is just as important as having the set working properly.

11. Are customers complaints handled promptly and courteously? A customer with a complaint is dangerous. If you can smooth out his complaint to his satisfaction, you win more customer confidence.

These are some of the things which make people buy in a particular store. If your appraisal of your own business is good, don't depend on it alone. Ask the opinion of other people who are in a better position to judge your business from the customers point of view. Many helpful suggestions can be offered by employees, business associates, and suppliers.

The best people to ask for opinions are your customers. Old customers who no longer do business with you may give you valuable suggestions on any short-comings which affect your business.

(Continued on page M-24)

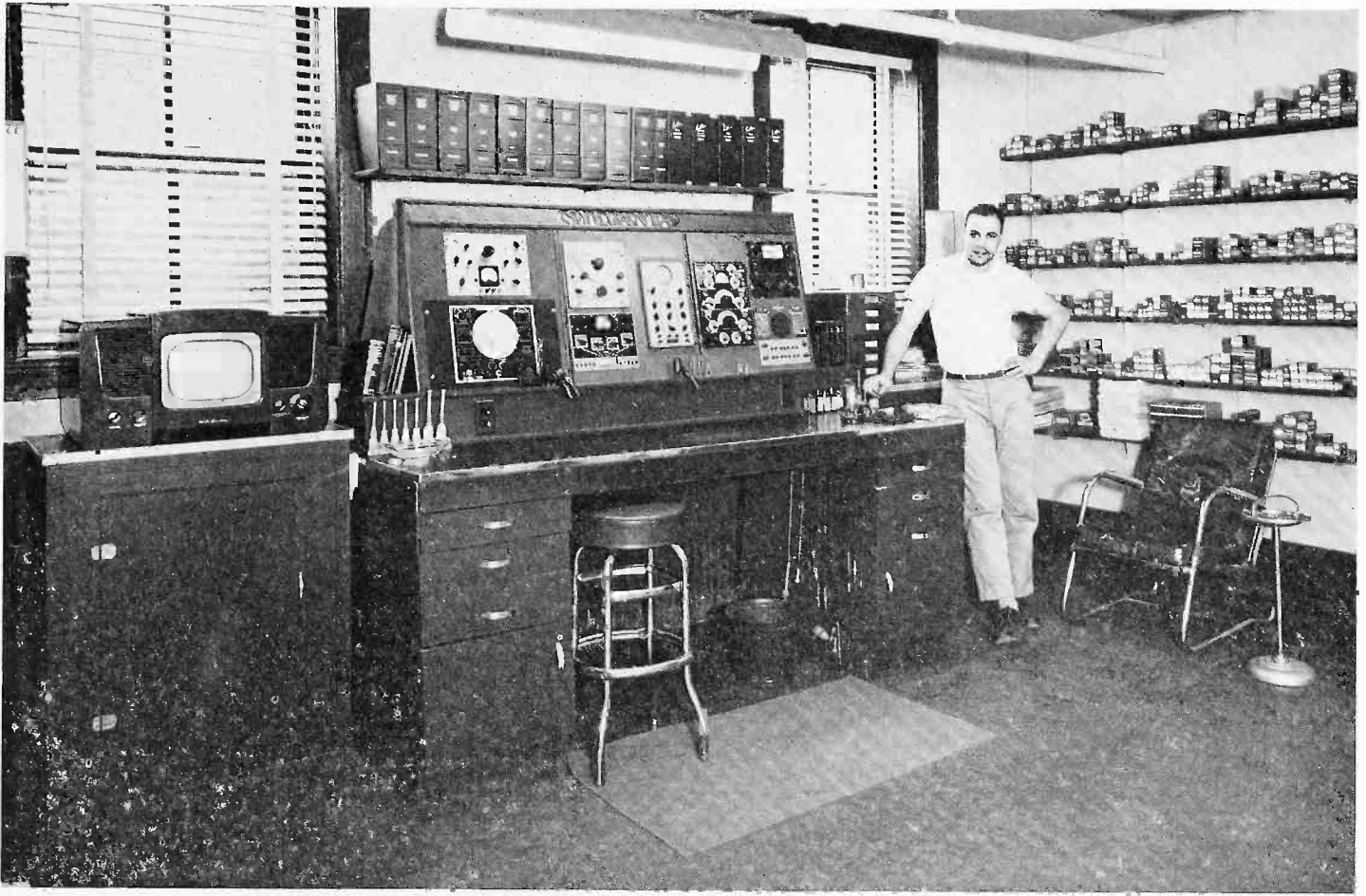

Above is the service bench of Miller's Radio Sales and Service, Toulon, Ill. Proprietor Roger Miller credits his Sylvania Service Bench as being the most valuable tool in his service department.

Service Starts At The Service Bench

A valuable asset to every radio and television serviceman is his service bench. This important piece of furniture is the heart of the money-making part of the service business. It is here that the greatest number of hours in any serviceman's day are spent. It is here that the service dealer must work efficiently to produce the greatest amount of work for the least effort and thus make a reasonable profit.

For several years Sylvania has made available to service dealers a custom made bench which is designed to fill the major requirements of any technician. One proud owner of the bench is Roger Miller, Miller's Radio Sales and Service, Toulon, Ill. Mr. Miller finds that

his Sylvania Service Bench is a very valuable asset in his service work.

"We think the Sylvania service bench is the most attractive and useful tool in our service department. It presents a professional appearance and saves hours every day in service work," writes Mr. Miller.

Speaking of Sylvania products Miller says, "We heartily endorse Sylvania Products and use them whenever we can!"

The advantages of adequate working area are well expressed by Roger Miller. Good design and functional utility in a service bench makes way for efficient, fast service work. Well arranged test equipment, convenient tube and parts

storage and easily reached reference material contribute greatly to the speed and ease of servicing. All of these things are incorporated in the service department of Miller's Radio Sales and Service.

Miller is typical of many service dealers who find that efficient servicing is dependent on a well organized service bench. The great number of steps save each day through the formal organization of tools and test equipment contribute immeasurably to increased profits, speedier service, and more customer satisfaction.

Whether your service bench is a Sylvania Bench or one of your own design, any service dealer will find numerous advantages in a well planned service shop.

SYLVANIA NEWS

TECHNICAL
SECTION

JUNE-JULY 1950

Copyright 1950
Sylvania Electric Products Inc.

VOL. 17, NO. 6

The information in Sylvania News is furnished without assuming any obligations

Technical Editor A. V. BALDWIN

NEW OSCILLOSCOPE for TELEVISION ANALYSIS

New Sylvania Type 400 Television Oscilloscope is result of survey of active television servicemen. It has seven-inch screen, high sensitivity, wide frequency range and many other features.

High performance characteristics of the new Sylvania Television Oscilloscope Type 400 make it well adapted for a wide variety of laboratory, service, and industrial work on all kinds of electronic equipment. Although it was originally designed especially for use by television servicemen, many engineers will value a number of special features, such as very high sensitivity, frequency range useful to 4 Mc, push-pull amplifier circuits with cathode followers, frequency compensated attenuator and the large seven-inch screen. The complete specifications of the Type 400 Television Oscilloscope are given in the accompanying table.

Before the design of the Type 400 Oscilloscope was undertaken, an extensive survey among active television servicemen and a field test in major television areas was made to determine the most desirable characteristics for an oscilloscope to be used in servicing television receivers. As a result of this preliminary work the basic concept of an oscilloscope designed especially for servicing television receivers was formulated. First of all, a seven-inch cathode ray tube should be used. The sensitivity should be high enough so that the small values of voltage found in some circuits would produce a pattern large enough to be examined conveniently. Accordingly, it was determined that the most desirable vertical sensitivity would be of the order of ten millivolts rms (sine wave) per inch of deflection (peak to peak). It was also felt by the servicemen interviewed that a frequency band-width sufficient to show the video signal in detail was a desirable characteristic. The Sylvania Oscilloscope Type 400 was designed around these basic requirements, and the model now in production not only covers the needs of active television servicemen, but it is also an excellent general-purpose instrument for laboratory and industrial work. The characteristics which make it a good television oscilloscope also make it a good laboratory instrument.

In addition to those basic features mentioned above, the Type 400 Oscilloscope contains many more features which increase its usefulness and its convenience of operation. The exceptionally high input impedance

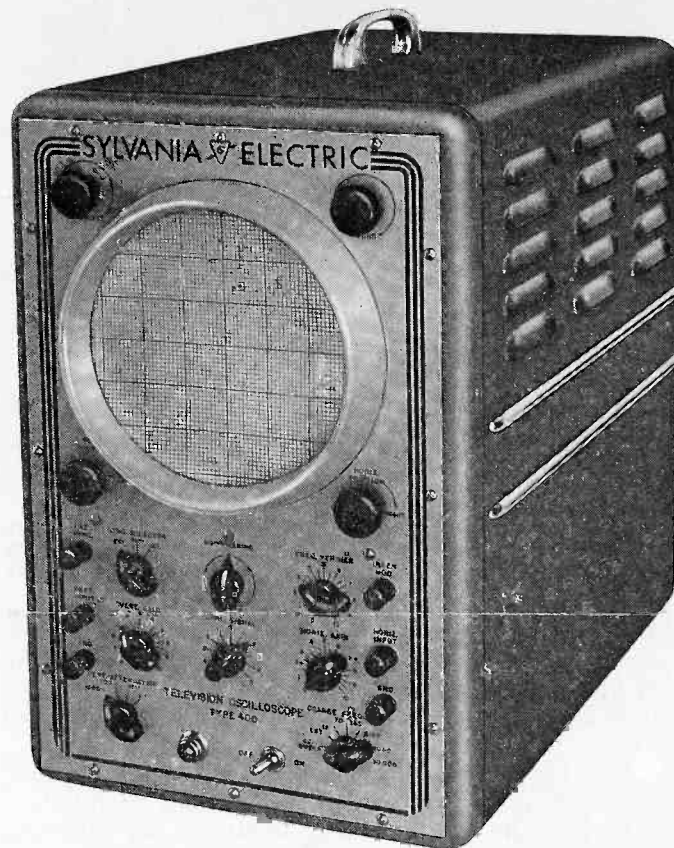

FIG. 1—The circuit features of the Type 400 Television Oscilloscope which make it a good television service instrument also make it a good instrument for general purpose laboratory and industrial use.

of five megohms and 26 micromicrofarads permits probing into circuits with very little disturbance to the circuit. A four-position frequency compensated step attenuator and a low-impedance smooth attenuator insure faithful reproduction of waveforms at any gain setting. The multivibrator sweep circuit gives linear sweep frequencies from 15 cycles to 50 kilocycles with a rapid return trace. A control is included for synchronizing to either positive or negative signals. A wide-range 60-cycle phasing control permits stabilization of the pattern when the internal 60-cycle sine wave sweep is used. The use of the internal sweep eliminates one set of leads during alignment operations. A bright trace is assured by a high acceleration voltage of 2200 volts. Push-pull amplifiers are used to provide balanced and non-astigmatic deflection.

Direct application of the signal voltage to the deflection plates of the cathode ray tube may be made by connecting the leads to terminals on the rear panel and disconnecting the amplifiers with the switches

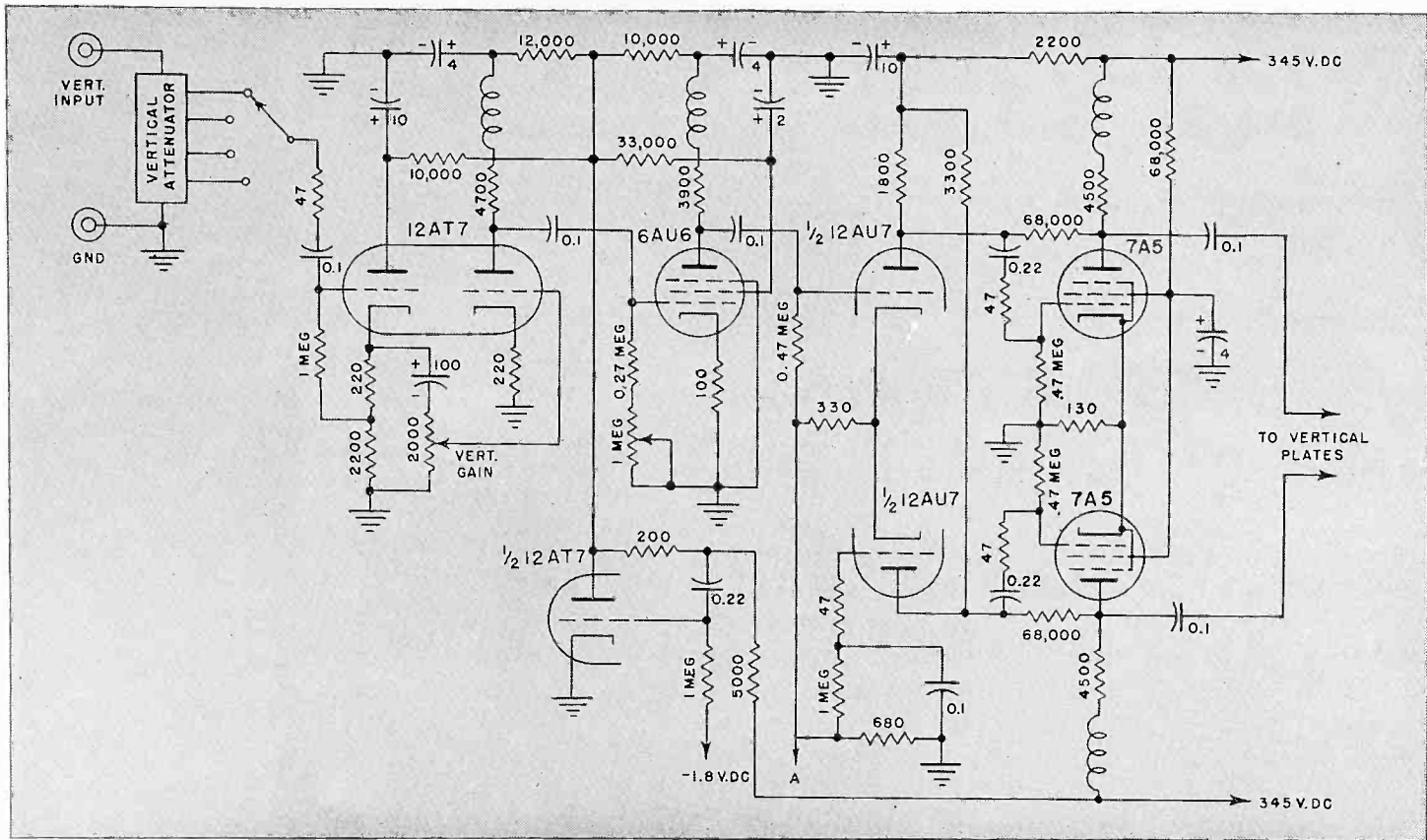

FIG. 2—Circuit diagram of the vertical deflection amplifier. The cathode follower circuit of the first stage permits a very high input impedance combined with an extended frequency

range. The high gain and wide frequency response of this amplifier permit study of the very sharp pulse voltages found in a television receiver and other electronic equipment.

provided for this purpose. The sensitivities under these conditions are approximately 24 volts rms per inch peak to peak for the vertical plates and approximately 26 volts rms per inch peak to peak for horizontal plates.

An ac signal may be applied to the control grid of the cathode ray tube through the intensity modulation terminal on the front panel to modulate the intensity (brightness) of the trace. When the instantaneous modulating voltage is positive the intensity of the trace is increased and when it is negative the intensity is decreased. Intensity modulation is very useful in many instances when it is desirable to superimpose reference markers on a pattern.

Extensive shielding is used to prevent pickup and amplification of interference by the high gain amplifier. Operation of components within their temperature ratings is assured by placing the heat producing circuit elements in location where the heat is carried away by ventilating air currents and by the use of an unusually large number of ventilating louvres and holes in the cabinet and the chassis. Even under conditions of high ambient temperature, the Type 400 Oscilloscope operates well within the temperature ratings of the components.

An important feature is the safety glass shield in front of the cathode ray tube to protect the operator and to prevent mechanical damage to the tube from external sources. A cross-hatched screen is placed directly in front of the cathode ray tube for convenient measurement of the deflection of the pattern. An exclusive rubber mount is used to cushion the cathode

ray tube. The rubber mount extends out from the screen and the inside surface is cylindrical so that a paper mask can be used to shield the screen in very bright locations. The Sylvania Type 400 Oscilloscope is supplied with a type 7JP1 cathode ray tube with a green trace, or if it is desirable, a standard seven-inch television picture tube, type 7JP4, with a white trace can be used.

Vertical Deflection Amplifier

To produce a peak to peak deflection of one inch on the screen it is necessary to apply 24 volts rms (sine wave) to the vertical deflection plates. It is, therefore, necessary that the vertical deflection amplifier have a voltage gain of 2400 or 68 db, to provide the specified vertical deflection sensitivity of 10 millivolts rms per inch. It is also necessary that the amplifier have a uniform response over the frequency range from 10 cycles to 2 Mc dropping smoothly to a still useful value at 4 Mc, and a very high input impedance. The circuit diagram of the vertical amplifier is shown in Figure 2.

The first stage makes use of a cathode follower circuit which permits the input impedance to be very high, 5 megohms, and the output impedance of the stage to be very low. The smooth vertical gain control is in the cathode follower circuit where it has no effect on the frequency response. The gain of this stage is quite low, slightly less than 1, and it serves to match the high impedance input to the low impedance gain control and to reduce the input capacitance. The signal is fed to the second triode of the type 12AT7 tube and then to a type 6AU6 miniature pentode. The

B plus voltage at this point is decoupled by a circuit using one triode section of a type 12AT7 tube. This circuit reduces the interference from ac hum and from high-level signals in other parts of the circuit.

From the type 6AU6 tube the signal is fed to the grid of one section of a type 12AU7 duo triode tube. The cathodes of this tube are connected together and the grid of the second section is grounded to ac. The second section of the 12AU7 is operated as a grounded grid amplifier. This results in the signals obtained from the plates of the two sections being 180 degrees out of phase with each other. The signal on the plate of the first triode is 180 degrees out of phase with the grid voltage, and the signal from the plate of the second triode will be in the same phase as the signal on the grid of the first triode. There is no phase reversal in the cathode coupling of the two triodes, nor through the grounded grid amplifier. The two out-of-phase signal voltages are then applied to the grids of the push-pull 7A5 power amplifier tubes. The voltage swing of the two output tubes is sufficient to produce a deflection on the screen of much more than the diameter of the screen without distortion.

High frequency compensation is used in several of the stages to make the response uniform to 2 Mc and dropping approximately 6 db at 3 Mc and 12 db at 4 Mc. Peaking coils connected in series with the plate load resistors are used for this purpose. Also, several of the stages have low frequency boost networks in the plate circuits to make the response uniform at very low frequencies.

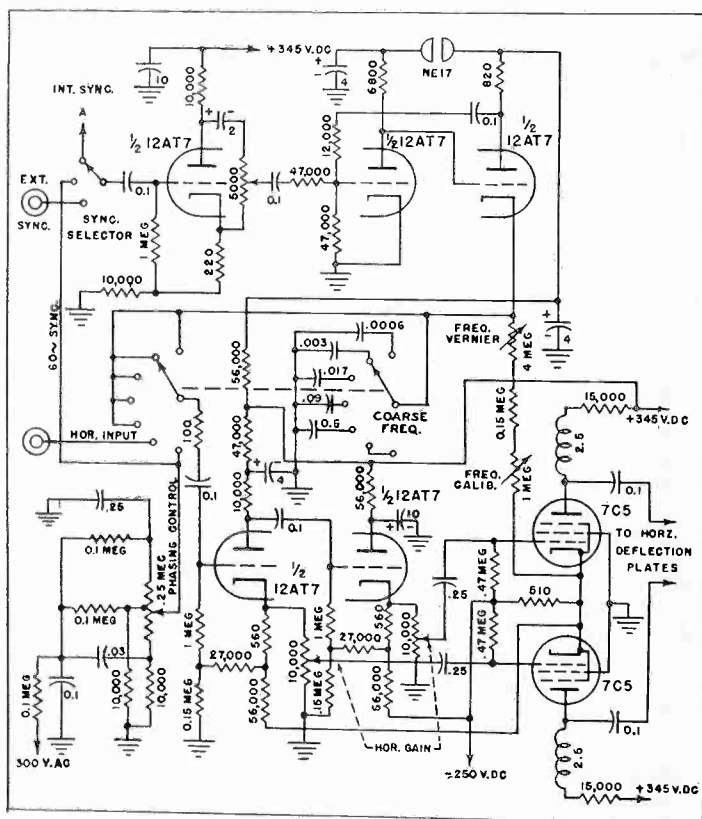

FIG. 3—Circuit diagram of the horizontal deflection amplifier and the sweep generator. A hard tube multivibrator is used to obtain the saw-tooth voltage for the linear sweep. Positive and negative power supplies are used to provide adequate voltage swing on the output tube plates.

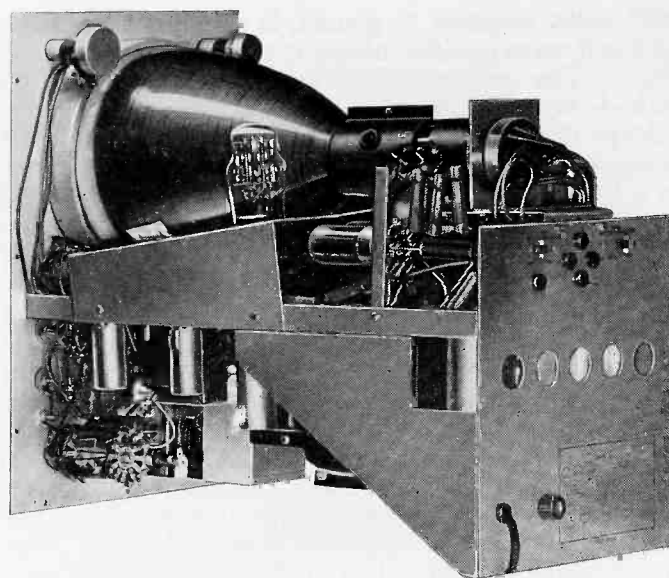

FIG. 4—Internal view showing the location of the various components. Shielding and ventilation are very important in obtaining long satisfactory service.

Horizontal Deflection Amplifier

The horizontal deflection amplifier requires much less gain than the vertical amplifier and the frequency response need extend to only 600 kc to pass sawtooth waves up to 50 kc. The input to the horizontal amplifier may be the sawtooth wave from the sweep generator, a 60-cycle sine wave whose phase may be varied, or it may be a voltage from an external source. The signal is applied to the grid of a triode section of a Type 12AT7 tube and the input impedance is 5 megohms. The output of the tube is split between the plate and cathode circuits. The portion from the plate circuit (reversed in phase) is fed to the grid of the second section of the Type 12AT7 and then to a potentiometer in a cathode follower circuit and two potentiometers which are operated in tandem as the horizontal gain control. The two signals are now about equal in amplitude and of the opposite phase. They are fed to the final push-pull stage and then to the horizontal deflection plates of the cathode ray tube.

Sweep Generator

The sweep generator consists of a vacuum tube multivibrator whose frequency range is determined by the choice of condenser in the cathode circuit of one section of the Type 12AT7 tube. The exact frequency is set by adjustment of the frequency vernier potentiometer. The sweep signal may be synchronized by a signal from a choice of three sources. It may be derived from the signal applied to the vertical deflection amplifier, the 60-cycle line voltage, or from an external source. With the sync control in approximately the center position, no synchronization takes place and as it is rotated in either direction positive or negative components of the synchronizing voltages may be used. The frequency range of the sweep generator is from 15 cycles to 50 kc for linear sweep.

Conventional power supplies are used for both the high voltage and low voltage. The high voltage of

2200 volts, negative to ground, is supplied by a Type 2X2 half-wave rectifier tube and a resistance-capacitance filter. The voltages for various electrodes of the cathode ray tube are supplied through a low impedance voltage divider which provides good regulation. The positive low-voltage is supplied by a Type 5V4G tube in a full-wave rectifier circuit. The dc voltage at the output of the filter is 345 volts. A negative dc voltage of 250 volts is supplied by a Type 50X6 in a full-wave rectifier circuit.

The Type 400 Television Oscilloscope may be used for a wide variety of measurements in television receivers and other types of electronic equipment. The sensitivity is sufficient to produce a convenient sized pattern even with very small signal strength. The input impedance is much higher than is usual in such instruments and critical circuits are disturbed very little. The frequency range is great enough to produce an excellent pattern of the television video signal in its entirety. The video signal in the rf or if stages may be observed directly, and by using a sweep generator such as the Sylvania Type 500 and a demodulator probe, the response curve of any stage may be produced on the screen. The waveforms in the deflection circuits of the television receiver are accurately portrayed. This is of considerable help in tracking down components of incorrect value and those which are defective. The high sensitivity, wide frequency range, and other characteristics of the Type 400 Television Oscilloscope which make it valuable in analyzing television receivers also make it a very useful instrument for general laboratory work.

Sylvania Television Oscilloscope—Type 400

Specifications

Power line: 105/125 volts, 50/60 cycles.
 Amplifier frequency response: Vertical, 10 cycles to 2 Mc. within 3 db (sine wave), useful to 4 Mc.
 Horizontal, 10 cycles to 600 kc. within 3 db (sine wave).
 Sensitivity: Through vertical amplifier, 10 millivolts (0.010 volt) rms sine wave for 1 inch of deflection (peak to peak).
 Through horizontal amplifier, 0.5 volt rms sine wave for 1 inch of deflection (peak to peak).
 Direct to vertical plates (D3 and D4), 24 volts rms sine wave for 1 inch of deflection (peak to peak).
 Direct to horizontal plates (D1 and D2), 26 volts rms sine wave for 1 inch deflection (peak to peak).
 Input impedances: Vertical amplifier, 5 megohms, 26 mmf.
 Horizontal amplifier, 5 megohms, 31 mmf.
 Deflection plates, 4.7 megohms, 16 mmf.
 Sweep Synchronization: Phase inverter type, variable in amplitude and polarity.
 Maximum d-c voltage on vertical input terminal: 600 volts.
 Maximum a-c voltage on vertical input terminal: 700 volts rms.
 Maximum a-c voltage on horizontal input terminal: 25 volts.
 Sweep frequency: 15 cycles to 50 kc.
 Tube complement: 1—Sylvania Type 7JP1
 1—Sylvania Type 12AU7 2—Sylvania Type 7C5
 4—Sylvania Type 12AT7 1—Sylvania Type 2X2
 1—Sylvania Type 6AU6 1—Sylvania Type 5V4G
 2—Sylvania Type 7A5 1—Sylvania Type 50X6
 Power consumption: 200 watts at 117 volts, 60 cycles.
 Cabinet size: 17 $\frac{1}{16}$ " high, 11 $\frac{3}{8}$ " wide, and 17 $\frac{3}{4}$ " deep.
 Weight: 45 pounds.

Type 219-220 Tube Tester Settings

Chart A -- Revision 2

TYPE	A	B	C	D	E	F	G	K*
1E7GT	2.0	2	17S	58	7	48Y	3	-
	"	"	"	62	"	58Y	6	-
1T4	1.4	1	457	64	7	036Y	2	-
	"	5	147	"	"	"	"	-
2D21	6.3	3	45	10	4	17Z	6	2
	"	"	47	"	"	15Z	"	-
6AU5	6.3	2	7	15	7	18Z	5	3
6AV6	6.3	2	7	12	7	18Z	5	3
6AX5GT	6.3	2	7	14	7	Z	3	8
	"	"	"	"	"	"	5	"
6BN6	6.3	3	4	34	4	25U	7	1
	"	"	"	21	"	056U	"	"
6CB6	6.3	3	4S	34	4	16Y	5	2
6CD6G	6.3	2	7	12	7	58Z	9	3
6C4	6.3	3	245	36	4	6Z	1	7
	"	"	124	"	"	"	5	"
6R8	6.3	4	35	44	5	8V	9	7
	"	"	"	35	5	T	6**	7
	"	"	75	"	"	"	2**	3
	"	"	35	"	"	"	1**	7
6S4	6.3	4	13578	27	5	6Z	9	2
6U4	6.3	7	8	12	8	Z	5**	3
7C6	6.3	1	48	38	8	3T	2	7
	"	"	"	40	"	T	5	7
	"	"	"	"	"	"	6	7
45Z5(GT)/40Z5	50.0	2	37	12	7	Z	5**	8
811A	6.3	1	4	23	4	3U	9	-
1284	12.6	1	8	37	8	036Y	2	7

Inserts For Technical Manual

The sheets enclosed in this issue will provide data on four recently announced tube types for use in the Sylvania Technical Manual (Seventh Edition). Following issues of the NEWS will contain data on other recently announced television types.

The spreader tool for inserting these extra pages in the Technical Manual is shown in detail on page 84 of the appendix of the present manual or is available in wood from the Sylvania Advertising Department for 25c.

There's Profit In Good Test Equipment

One of the intangible things about the service business is the exact worth of a piece of testing equipment. This is especially true in cases where dealers lack certain instruments and depend on "cut and try" methods to fix receivers. To understand how much simpler work becomes with the proper tools is a lesson to be learned only through experience.

George Hoeh, service dealer of Punxsutawney, Pa., is one man who has learned through experience the value of good equipment to aid in speeding his service work and increasing his profits. In having adequate testing instruments available to do a service job, Hoeh finds that he can service sets faster because his instruments help spot troubles quickly. Once the troubles are found, repairs are made quickly and surely.

Equipment in the shop of George Hoeh includes Sylvania Tube Tester Type 139, a Sylvania Oscilloscope Type 132, a Sylvania Polymeter Type 134, and the Sylvania AM-FM Signal Generator Type 216.

Three of the test instruments are mounted in the panel of his

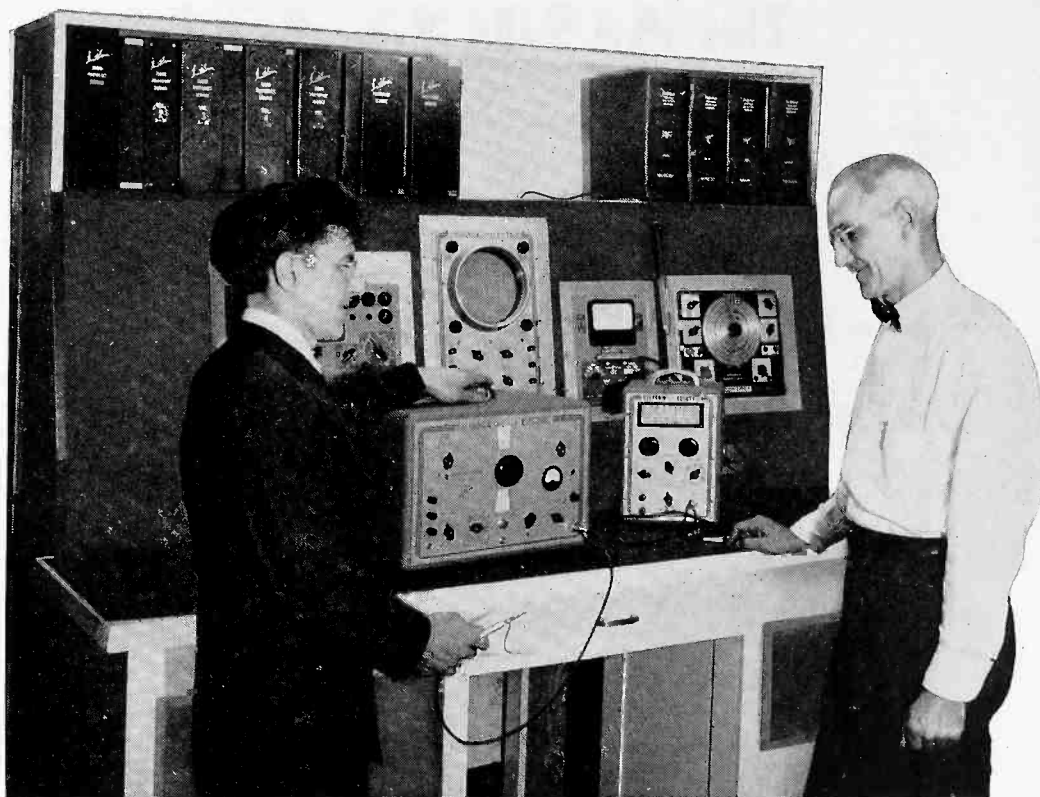

Paul Boyer, left, salesman for Hollenbach Radio, points out features of Sylvania AM-FM Signal Generator to George Hoeh. The new Generator is the fourth Sylvania test instrument obtained by Hoeh to help speed service work.

attractive service bench. The Sylvania AM-FM Signal Generator, which has just been purchased by Hoeh to replace an older AM Signal Generator, will soon be mounted in the panel.

Hoeh's service bench is well equipped for efficient service. The bench contains four large drawers for use in storing tools and equipment and two sets of eight smaller drawers to hold small parts such as

resistors and condensers. Also close by is reference material on sets and servicing.

During the twenty odd years Hoeh has been in business he has learned the value of good servicing techniques in building his service business. Good test equipment has helped him give faster service and helped to develop satisfied customers who make any business a success.

MaySet Production

Production of home radio receivers including portables, increased in May as television set production dropped slightly below the record level of the past two months, according to RMA member company reports.

Home radios produced in May totaled 693,592 sets and auto radios numbered 206,464. Television set production in May amounted to 376,227 sets compared to 420,026 sets in April.

Total number of all types of sets produced during the month was 1,276,283. This brings the total number of radio and television receiving sets produced by RMA member companies to date this year to 6,197,897 sets. Of this total, 2,024,183 are television sets.



Set to go to work to give better-than-ever service is George Hoeh of Hoeh Radio, Punxsy, Pa. Note the three Sylvania test instruments in the panel. Instrument at left is the latest addition to his shop — a Sylvania AM-FM Signal Generator.

This Ad Sells Your Service



"I gotta do something about this... it whistles!"

RADIO TELEVISION SERVICE
SYLVANIA RADIO TUBES
Authorized Dealer

LOOK FOR THIS SIGN OF DEPENDABLE RADIO SERVICE

Whistling sounds in your set really give reception a black eye. Get rid of unwanted noises now by calling the radio serviceman who displays the Sylvania sign. He'll make your radio play as it did the day you bought it. How does he do it? With Sylvania testing devices to detect trouble spots... with repair "savvy"... with Sylvania radio tubes to restore crystal-clear performance. Look for the sign of dependable service for good radio work at fair prices.

SYLVANIA TELEVISION PICTURE TUBES ARE GUARANTEED FOR ONE YEAR

SYLVANIA
RADIO AND TELEVISION PICTURE TUBES
PRODUCTS OF SYLVANIA ELECTRIC PRODUCTS INC.

Month after month, Sylvania tells readers of the four top family magazines about your service. In large half page ads like the one reproduced on the left, Sylvania tells the story of your service business and asks the customer to visit your shop for expert radio and television repair.

To aid dealers in building their service business, Sylvania makes available a complete advertising campaign for use in your own locality. This personalized campaign contains all the necessary tools for helping you increase your business. The campaign identifies you as the dealer talked about in Life, Colliers, Saturday Evening Post and Look.

Identify yourself today with this intensive effort to increase your business and make more money. Write for the big bright RADIO TELEVISION SERVICE decal to identify your store as the one Sylvania advertises in national magazines. Ask for information too on the Co-ordinated Advertising Campaign for your own locality. You can increase your business as much as 50% by using this accepted and proven campaign. The address? Advertising Dept. N, Sylvania Electric Products Inc., Emporium, Pa. Write today. A big, new campaign will be announced soon.

Whose Hot?

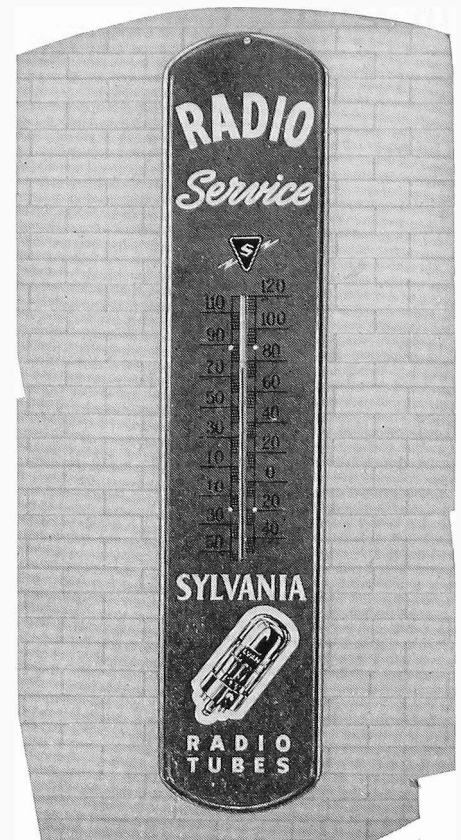

Now is the time to satisfy the public's curiosity about the weather. The big Sylvania thermometer will settle the temperature question and sell your service. See your Sylvania Distributor today. He has them in stock. The price is \$2.95.

How to Keep Regular Customers

(Continued from page M-21)

After obtaining criticisms and suggestions from the various sources, study your own operations and compare them with your competitors. When a criticism is justified, correct it. When you receive suggestions for improvement which cannot be undertaken immediately, keep them in mind and take care of them as soon as possible.

By seeking and eliminating cause of customer complaints and by seeking and adopting suggestions for improving your store and your service, regular customers will find it a greater pleasure to do business with you and they will help to make regular customers out of occasional ones,



Keep promises to customer with prompt deliveries

Distance Record

Clarence Simpson, Sylvania commercial engineer who conducts service meetings all over the country still continues to draw large groups of dealers in every city in which he speaks. At a meeting sponsored by Hough Radio Supply, Cheyenne, Wyo. E. L. Bowler, Bowler's Radio Service, Hardin, Mont. drove 365 miles to attend. After the meeting Bowler said that the 730 mile round trip was well worth the time and trouble.

Next time Clarence Simpson is scheduled to appear in your locality, don't fail to attend.

CRYSTAL DIODE CLIPPINGS

BY ROBERT C. MOSES

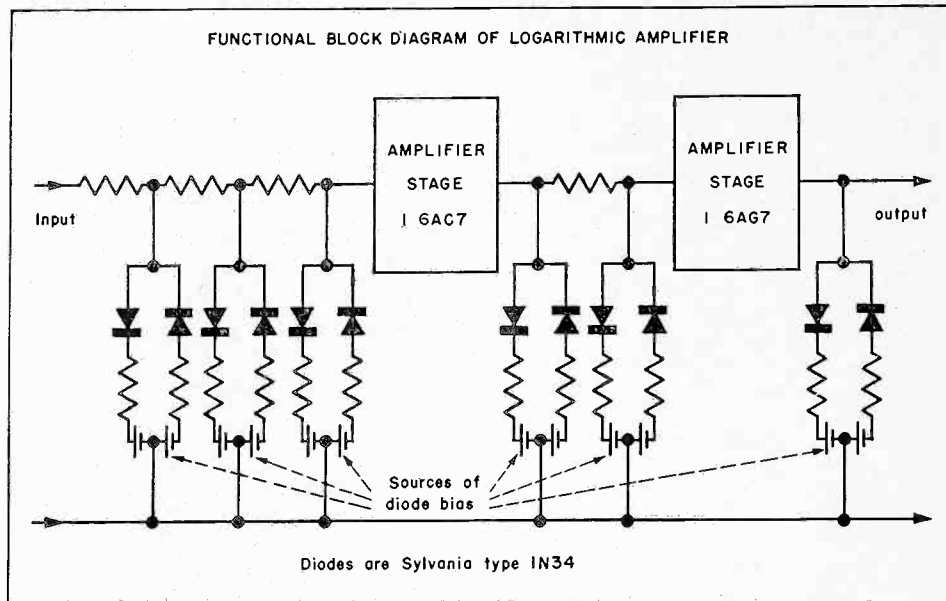

Above is a functional block diagram of a logarithmic amplifier for use in recording radio interference voltages. This application for Germanium Crystal Diodes was submitted by George Epprecht, Berne, Switzerland. Epprecht was awarded first prize in the Sylvania News Contest for this application.

"Hands across the sea" this month in the SYLVANIA NEWS Crystal Diode Applications Contest. Congratulations and first prize go to Mr. George Epprecht, Berne, Switzerland, for his application of crystal diodes in a logarithmic amplifier for use in recording of radio interference voltages having an unusually large dynamic range. Mr. Epprecht's amplifier produces an amplitude characteristic which is logarithmic to within ± 0.5 db over a range of input levels of .005 volts to 15 volts, and covers a frequency range of 500 cycles to 2.5 megacycles.

By means of six pairs of 1N34 crystal diodes, each of which is suitably biased, the dynamic input voltage range of 70db is broken down into seven decades of 10 db each. Each diode pair produces a linear response within its respective decade. The overall logarithmic function is thus approximated by a series of linear characteristics having different slopes.

Space does not permit reproduction of the entire schematic of Mr. Epprecht's amplifier, however, the important functions are shown in the block diagram above.

According to Mr. Epprecht's description in the first group of diodes,

1, 2, and 3, the upper part only of the logarithmic function is generated, whereas the medium and low voltages are passed linearly. The second diode group, 4 and 5, produces the intermediate portion of the log function, while for low and high levels this group operates in a linear fashion. Finally in the last group, 6, the lowest voltages, having passed now through two linear stages are operated upon by the diodes. The portion of the dynamic range over which any group of diodes acts is adjusted by suitable selection of bias voltages and impedance levels within the particular group. In Mr. Epprecht's amplifier, the bias batteries shown are, of course, replaced by a regulated power supply.

The advantages of this arrangement are that all diodes have bias voltages between 1 and 4 volts, thus no diode is overloaded. Also, both amplifier tubes are operated at input levels such that excessive grid swings and non-linear distortion is avoided.

Mr. Epprecht points out that by using more amplification and additional groups of appropriately biased diodes, this principle can be extended to even higher levels, such that logarithmic response over

a 100 db range can be achieved.

Second prize this month goes to Mr. John Divilbiss of Winfield, Kansas for his application of crystal diodes in a clipper circuit to insure stable synchronization of oscilloscope sweep oscillators, and third prize to Mr. Maurice Kennedy of Los Angeles, Calif. for a remote carrier and percent modulation indicator for broadcast and communication transmitters.

Winners of honorable mention have been notified by mail.

Each month SYLVANIA NEWS sponsors a new contest for unique applications for the use of germanium diodes. There is no limit to the number of times you may enter or the number of times you can win. Winners of the first prize are awarded an assorted package of Sylvania diodes valued at \$15.00. Second prize winners receive an assortment of diodes worth \$10.00 and third prize winners receive \$5.00 worth of Sylvania Germanium Diodes. Twelve additional prizes for honorable mention consisting of two Sylvania 1N34A diodes are also given for applications submitted.

ON THE COVER

Screen settling belt in Sylvania's Ottawa, Ohio television picture tube plant. Glass blanks are thoroughly washed when they are received from the glass manufacturer. Bulbs are placed on conveyor and a solution containing the fluorescent screen material is poured into the bulb. Bulb moves slowly along conveyor and material settles out of the suspension onto the inside face of the tube. Liquid is then poured off automatically at far end of the conveyor. Careful quality control of screen material and during the settling process insures users of Sylvania Picture Tubes of high quality screens and superior performance in any type television set.

Distributors "Play Ball" at Chicago



One popular spot at the Chicago Parts Show held last month was the Sylvania Booth. Over 3,000 visitors at the show stopped at the booth to try their luck at winning free tickets to the ball game. Above, model Helen Olson hands Leslie Rucker, Sylvania distributor from Washington, D. C., a chance on the ball tickets. Looking on is Sam McDonald, New England representative for Sylvania and Jim Ritter, sales service supervisor.

Facts & Figures...

Broadcasters Number 3226

The number of radio and television broadcast stations authorized by the FCC in the United States and its possessions totaled 3226 as of June 7. This total includes 2295 AM stations, 740 commercial FM outlets, 82 noncommercial FM stations and 109 television stations. A breakdown of the totals shows that Texas leads all states in the total number of broadcast stations with 222 AM, FM and TV authorizations is led by New York with 13, Ohio with 12 and California with 11 TV outlets.

TV Town Meetings Scheduled For 60 Cities

The television broadcasting industry will join with the RMA late this summer in an educational program designed to help retailers sell more television sets and make sure set owners are satisfied. The program, announced in March by the RMA includes a series of slide films to be shown at Town Meetings of Television Dealers in 60 cities during August and September. The slide films to be shown at these meetings include suggestions for the television dealer on advertising and merchandising, sales business management, and service department operation. This non-commercial, undertaking is being financed by 17 television set manufacturers. The meetings will be held in conjunction with local distributors and telecasters in each of the 60 cities.

SYLVANIA NEWS

SYLVANIA ELECTRIC PRODUCTS INC.
P. O. BOX 431
EMPORIUM, PENNA.

Sec. 34.66, P. L. & R.
U. S. POSTAGE
PAID
Permit No. 1
Emporium, Pa.

For:

J. A. Renville
163 Main St.
Luzerne, Pa.

A

POSTMASTER: IF UNDELIVERABLE FOR ANY REASON, NOTIFY SENDER, STATING REASON, ON FORM 3547, POSTAGE FOR WHICH IS GUARANTEED.

Vol. 17, No. 6

JUNE, JULY 1950

PUBLISHED BY
SYLVANIA ELECTRIC PRODUCTS INC.

MANUFACTURERS OF SYLVANIA RADIO TUBES, CATHODE RAY TUBES, ELECTRONIC DEVICES, FLUORESCENT LAMPS, FIXTURES, WIRING DEVICES, ELECTRIC LIGHT BULBS, PHOTOLAMPS, RADIO AND TELEVISION RECEIVERS

In This Issue

NEWS
LICENSING THREATENS NEW YORK TELEVISION TECHNICIANS

MERCHANDISING
HOW TO DEVELOP AND KEEP REGULAR CUSTOMERS

TECHNICAL
NEW OSCILLOSCOPE FOR TELEVISION ANALYSIS

SYLVANIA NEWS

BOB PENFIELD, Editor

AUGUST 1950

VOL. 17, NO. 7

Copyright 1950, Sylvania Electric Products Inc.



Report On Color Television

The long road toward settlement of the color television question is getting shorter. Final briefs have been filed by the various interested parties and the FCC is now going over the data in an effort to reach an early decision.

The report of the Condon Committee on the status of color television developments has also been submitted to the Senate Interstate Commerce Committee. The committee, in their report refrains from definite recommendations but expresses the belief that color television is ready for standardization and that a single system, rather than multiple standards is advisable.

"No recommendation for the adoption of a specific system is given," the report declared, "since the committee believes that the decision to adopt a system must include consideration of many social and economic factors not properly the concern of the technical analyst. It is hoped that the report will provide a comprehensive and understandable basis on which the

technical factors may be considered in arriving at a decision."

The committee clearly points out the advantages and disadvantages of each of the three systems in relation to a list of nine important technical categories, but made it equally plain that the FCC would have to determine the actual weight to be assigned these categories.

What effect the present crisis in Korea and the increased efforts for defense will have on the future of color television remains to be seen. While the FCC is continuing their deliberations preparatory to issuing a decision, there is speculation as to what effect the present emergency will have on the Commission's findings.

The FCC decision may have to be shelved until the present rearmament program is completed in view of the anticipated demands on the production capacity and engineering talent of the radio-television manufacturing industry.

What Next?

What happens to radio and television now that the government has called for controls on production seems to be the big question now facing the industry.

It is generally anticipated that production of television and radio sets will be cut back sharply in the next few months. The mere impact of military procurement and industrial controls on vital materials and priorities will have a definite effect.

Proposed curbs on consumer credit are expected to slow down TV set buying concurrent with reduced production.

It appears certain that eventual reductions in the production of components and sets for civilian use will result from the top priority requirements of military services for electronic equipment, if not from actual limitation orders by the Government. The extent of such reduction will depend largely upon the capacity of the industry to absorb military orders while continuing civilian production.

The President has asked for legislation to restrain credit "as a further important safeguard against inflation." Although at this writing such legislation had not passed congress, a bill is before congress giving the President wide latitude in prescribing regulations with respect "to such kinds of consumer and real estate credit as, in his judgement is necessary."

The regulations may prescribe "maximum loan or credit values, minimum down payment and other rules which will directly affect time payment purchases of TV sets. Whatever the controls may be, it can be expected that they will undoubtedly affect the buying of TV sets.

In order to provide set purchasers the utmost satisfaction with their receivers, every effort should be made to maintain the best service and installation possible. This can only be done with adequate, well-trained staffs. Even though some localities have not felt the squeeze yet, it is important that plans are made for the future to take care of the coming volume of business.

Service Convention

The second annual Servicemen's Radio and Television Convention and Exhibit will be held September 25, 26 and 27 in Philadelphia, according to Dave Krantz, chairman of the show committee for the Philadelphia Radio Service Men's Association, sponsors of the show.

In addition to exhibits and demonstrations of radio and television equipment and products, a series of educational lectures will be presented to those in attendance at the show.

Service technicians and other people interested in the radio and television industry are invited to attend. Further information and reservations are available from the show committee. Inquiries should be sent directly to Dave Krantz c/o Harry Bortnick Advertising Agency, 138 S. 9th St., Philadelphia 7, Pa.

Technicians Wanted

Qualified television installation and maintenance technicians will be in greater demand than ever before in the coming fall and winter season. Estimates of receiver sales during the rest of this year indicate that three to four million sets will be sold before the end of the year.

This means that the servicing industry must be able to install and service, in the next five months, approximately as many television sets as were installed and serviced during the past four years.

The installation of 3,500,000 television receivers during the next five months means that an average of 700,000 sets will be installed each month. It means too, that installations will average about 25,000 per day during this period.

The magnitude of the service industry is just beginning to be realized. With the tremendous growth of television the need for well trained technicians becomes more imminent. There is little doubt that the industry will experience a serious shortage of trained men for some time to come.

SYLVANIA NEWS

AUGUST 1950—VOL. 17, NO. 7

Copyright 1950
SYLVANIA ELECTRIC PRODUCTS, INC.



**"We doubled our
store space...
increased our staff"**

Howard J. Hitzeman
Better Radio Inc.
Elmhurst, Ill.

Any business which grows steadily and expands is a healthy business. In order to become a healthy organization, a service organization must have not only technical skill, but it must use all means of keeping the public informed of that skill.

It goes without saying that advertising is as important to the radio and television service dealer as it is to any organization which must meet and survive competition.

Designed especially to stimulate service business for the dealer is the Sylvania Coordinated Advertising Campaign. This campaign is a complete promotion package which will pay any dealer who uses it a high return on his investment. This is not theory, but actual fact!

Typical of the more 6000 service dealers who have used the campaign regularly to help increase their business, is Better Radio Inc., Elmhurst, Ill. This organization has spent a better than average amount of money on promotion. Their efforts at getting more business has paid off handsomely in the past few months.

Last December Howard Hitzeman, president of Better Radio, purchased 48,000 postal cards with the Sylvania Coordinated Advertising Campaign. The cards cost him \$480 for the postage. They were imprinted with his store name and address, and the message on the cards tied-in with the current advertising carried by Sylvania in national magazines.

The cards were addressed by a

local letter service which charged Hitzeman 1/3 cent per card. In January of this year 12,000 cards were sent to each house in three Chicago suburbs, Elmhurst, Villa Park, Lombard and countryside.

The effects of the first mailing were almost immediate. Hitzeman reports that January business increased 33% as a result of his use of the campaign. Similar results have been obtained by Better Radio for the succeeding months of February and March. In all, according to Hitzeman, his service business has increased an average of 38% for the first three months of this year over a similar period last year.

"Due to the increased business we've had as a result of your campaign mailings, we have doubled our store space, increased our service staff from two to six bench positions, and added an outside staff for antenna installation," writes Hitzeman.

You too can increase your business by leaps and bounds by using the Sylvania Coordinated Advertising Campaign in your own locality. The campaign includes a complete kit of essential material for advertising your business in your own locality. The kit includes four full color window and counter cards, two large window streamers, four newspaper ad mats, four radio spot announcement booklets, and a sufficient quantity of direct mail postal cards for reaching every

(Continued on page M-28)



DISPLAYS

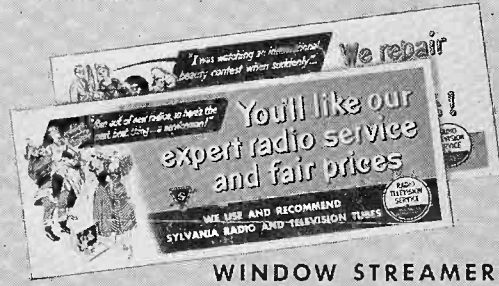

WINDOW STREAMERS



POSTAL CARDS



RADIO SPOTS



AD MATS

New Sylvania Multi-Bin Storage Unit

Now available from Sylvania Distributors is the new Sylvania Multi-bin. This new addition to Sylvania's growing line of helpful shop equipment for service dealers is a convenient storage unit for nuts, bolts, screws, small resistors and other small size equipment.

The new Sylvania Multi-bin is every service dealer's answer to where to store hard-to-find material. It is just the right size to fit conveniently on the back of a service bench or on any regular shelf. The Multi-bin contains three easy-to-reach trays, each of which has six separate compartments for storage. Each tray is $4\frac{3}{8}$ inches by $3\frac{1}{8}$ inches.

Overall size of the Sylvania Multi-bin is $19\frac{1}{2}$ inches long by $10\frac{1}{2}$ inches high. It is 10 inches deep. The bin is sturdily made of fine grade steel finished with a rich gray modeling. Storage trays and dividers are bright red with a hard lacquer finish. The ends are 22 gauge, and the trays are 24 gauge and the tray dividers are 26 gauge

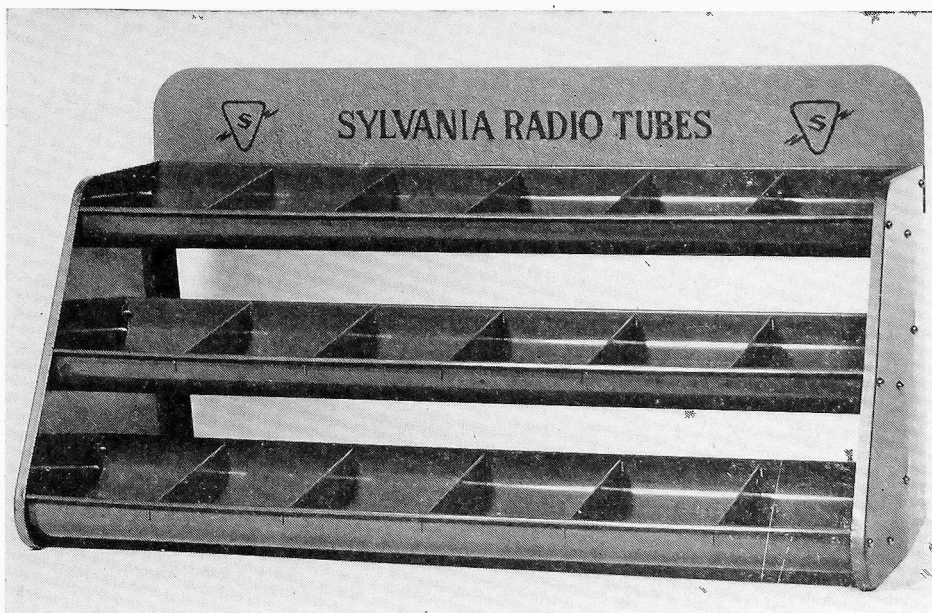

durable steel.

Keep track of those small elusive parts. Order one or more Sylvania Multi-bins for your shop. Price of this handsome and useful storage bin is \$2.00. Order from your

Sylvania Distributor or from the Advertising Department, Sylvania Electric Products Inc., Emporium, Pa. When ordering from Emporium, enclose your check, cash or money order.

Keep Your Manual Up-To-Date

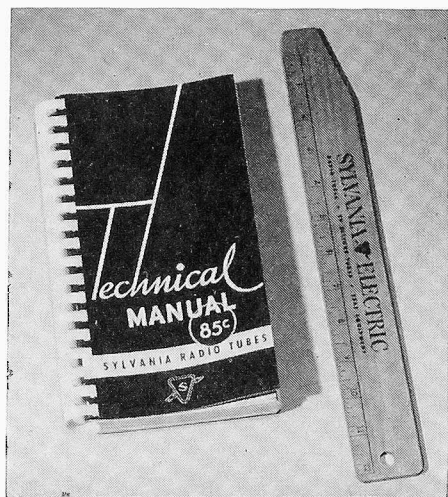

Your Sylvania Technical Manual is always up-to-date, thanks to the loose leaf service of new data sheets provided by SYLVANIA NEWS. These new data sheets include complete information about new tube types. They are furnished free as a service to readers and to aid in keeping servicemen, dealers and engineers abreast of tube developments.

This issue of SYLVANIA NEWS

contains two more data sheets with complete ratings and characteristics for four Sylvania Tube Types.

It is easy to insert these new data sheets in your Sylvania Technical Manual. Instructions for making a handy tool for this purpose are given on page 84 of the Manual. Sylvania has also designed a tool especially for this purpose and it is available from Sylvania Distributors or from the Advertising Department, Sylvania Electric Products Inc., Emporium, Pa.

The Sylvania Technical Manual Spreader Tool is a sturdy wooden 12 inch ruler which is shaped to spread the "combs" of the technical manual. The punched data sheets can then be inserted in their proper place in the book.

Price of the Technical Manual spreader alone is 25c. When purchased with the Technical Manual, the price of the two is \$1.00. Keep your tube Manual up to date at all times. Order your Manual and Spreader today. New data sheets will appear regularly as a supplement to the SYLVANIA NEWS.

Better Business

To assist manufactueres, distributors and dealers of radio and television to maintain high standards of doing business, the New York Better Business Bureau has prepared and published a 12-page manual of "Standards for Advertising and Selling of Radios, Television Receivers, Television Service, Home Appliances." The manual has been prepared with the co-operation of the various elements in the industry.

Included in the manual is information covering such varied subjects as unfair competitive claims, advertising layout, headlines, "bait" offers and "free" offers, "two for one" sales, price reductions, window displays, trade-in allowances, guarantees, and a host of other subjects which will help dealers in operating their business.

The book should prove valuable to all segments of the industry in maintaining better customer relations. It is available from the Better Business Bureau of New York City, 280 Broadway, New York 7, N. Y.

The information in Sylvania News is furnished without assuming any obligations

Technical Editor A. V. BALDWIN

SUMMER SERVICE FOR THREE-WAY PORTABLES

By G. M. Mitchell and William Snyder
Commercial Engineering Department

Small size, light weight, and switches give the three-way portables service problems all their own. This article points out some of the tricks used to reduce the time of servicing.

Three-way portable receivers are very popular because of their light weight and flexibility of operation. They are operated from either an ac or a dc power line, or from batteries contained within their case. The emphasis on small size and light weight, and the switching for operation from power lines or batteries contribute to the special service problems inherent in this type of receivers.

Several different circuits are used to connect the filaments to the power source. They are described below.

1. In an early circuit arrangement the tube filaments were connected in series for power line operation and a complicated switching system was used to connect the filaments in parallel for operation using a 1.5 volt battery. This required a battery of large current capacity. A typical application is shown in Figure 1.

2. More commonly used circuits have the tube filaments connected in series for both battery and power line operation as shown in Figs. 2A and 2B.

3. In some cases, series connected filaments are

FIG. 1—Typical circuit arrangement of early receivers in which the filaments are in series for power line operation and in parallel for battery operation. For reasonable time of operation between battery changes it is necessary to use A batteries of large capacity.

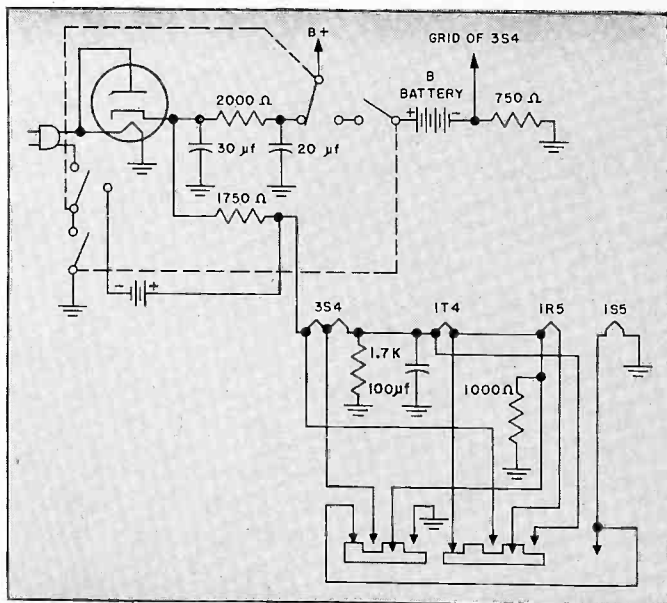

used for both power line and battery operation. These sets employ a filament type output tube for battery operation and a 117-volt cathode type diode-pentode tube, usually a Sylvania Type 117N7, for power line operation. On power line operation the diode section is used as a rectifier in the ac power supply and the pentode section is used as the audio output tube.

Due to current limitations of the rectifier, the filament power for the filament type tubes is obtained from a circuit arrangement such as shown in Figure 3. The filaments are wired in series, with a small value resistor R, except for the Type 3Q4. This series string parallels the cathode resistor. When this system is used, a tapped output transformer is required for proper loading of both output tubes.

Except in the last mentioned circuit, the filament voltage during power line operation is obtained through a dropping resistor from B plus of the power supply.

4. In some receivers the batteries are left in the circuit at all times. This tends to lengthen battery life, because on power line operation the voltages are usually higher than battery voltages causing a reverse current through the batteries.

Power Supplies

The 3-way receivers use either a vacuum tube rectifier or a selenium rectifier. A 117-volt tube is placed directly across the power line but tubes with a lower heater voltage rating have a dropping resistor in series with the heater. The dropping resistor may be in the line cord, a power resistor within the set, or a ballast tube.

Servicing Procedure

Defects in a 3-way portable receiver can be localized by determining whether defective operation exists at all times, or only when the set is used on one of the power sources, battery or power line. Should the defect be present on either type or power supply, a signal circuit, a bad tube, or a defective power supply circuit should be suspected. Suppose the trouble occurs only on battery operation, the cause of failure is then attributed to the batteries, to switching, or to any circuits which are only used on battery operation. Trouble that occurs only on power line operation is confined to the ac-dc power supply system, its switching,

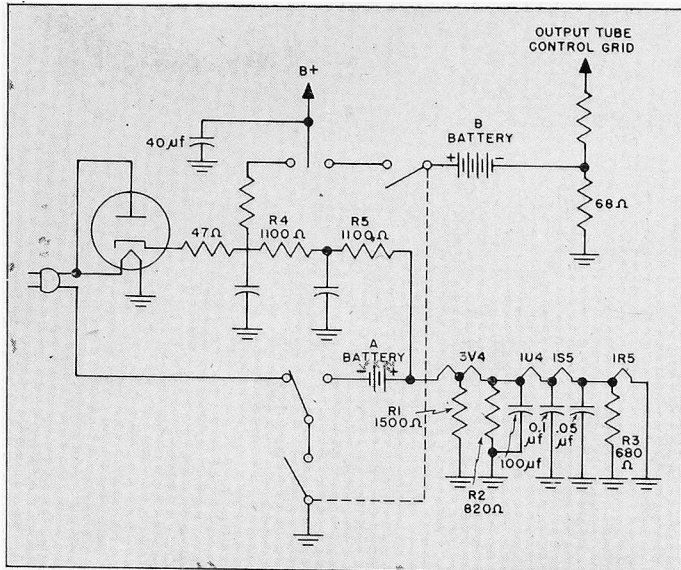

FIG. 2A—Filament circuit used in many 3-way portable receivers in which the filaments are in series for both power line and battery operation. This permits the use of simple switching.

or in circuits that are only in use on power line operation.

Trouble Occuring On Line Operation Only

Dead Receivers. Let us assume the rectifier tube has been checked in a tube tester and is in good condition. If the tube does not light in the receiver, there are several things that could prevent the rectifier from lighting. Always be on the look-out for a broken wire in the line cord especially close to the line cord plug, because with a portable receiver the plug is handled many more times than in the ordinary home receiver. If a line cord resistor is used, it may have broken from excessive handling or from a sharp bend of the cord. Dirty, sprung or broken contacts on the battery to power line operation switch should be suspected.

If the rectifier tube lights, there may still be trouble in the power supply. Resistors and condensers are used to filter both the B voltage and the A voltage.

FIG. 2B—Filament circuit with the series filaments supplied by a selenium rectifier for power line operation. Filaments remain in series for battery operation.

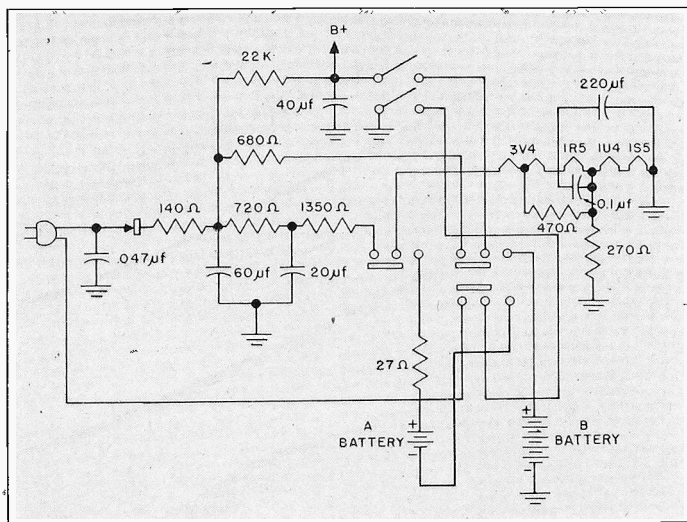

An open resistor or a shorted condenser may be at fault and can be found by using a voltmeter or ohmmeter.

A selenium rectifier may be used instead of a vacuum tube rectifier. There is no filament to light up in a selenium rectifier and it cannot be easily removed and tested such as a tube. The common failure in selenium rectifiers is a short circuit and it is recommended that they be checked for this before the power is turned on.

Hum. Hum in a 3-way portable is chiefly a fault in the ac power supply. Defective filter condensers are most likely to cause hum. Heater cathode leakage in the pentode section of the Type 117N7 tube or coupling between the diode section and pentode section of the tube will cause distortion in the form of hum. The most practical way to locate the fault or source of hum is to substitute another tube or condenser for the one that is suspected of causing trouble.

Distortion. A receiver may have objectionable distortion on power line operation and still function normally on battery operation. Abnormal operating voltages caused by a low emission rectifier tube, defective filter condensers, or a change in resistance of filter or dropping resistors may contribute to distortion. Always be on the alert for a receiver that uses a different tube type in the power output stage when operated on the power line such as shown in Figure 3. In a receiver of this design, greater volume is obtained on power line operation because the audio power output rating is higher on the Type 117N7 than on a filamentary type tube.

Trouble Occuring On Battery Operation Only

Dead Receiver. There are several defects to look for if the receiver is dead on battery operation, but operates satisfactorily on line operation. First, batteries should be replaced if their voltages are 25 per cent or more below normal. If the batteries appear to have some useful life perhaps the converter tube will not oscillate at reduced filament voltage.

A voltage reading taken across the oscillator grid resistor will determine whether or not the oscillator is functioning. The voltage reading obtained should be approximately 10 volts. This reading should be made with a high impedance voltmeter. If it is determined that the oscillator is not functioning and the filament voltage is greater than 1.2 volt the tube should be suspected of having low emission causing oscillator failure. A positive check is to try one or more new tubes, since most 1.4 volt filament type tubes are designed for operation on filament voltages as low as 1.1 volt.

Low Sensitivity. Low Sensitivity on battery operation only is usually caused by weak batteries. High resistance contacts on battery leads will cause a loss in performance due to the resulting decrease in operating voltages. In a receiver having a separate output tube for battery operation, the tube itself may be defective or weak.

General Servicing Technique

A circuit disturbance test can be used to determine at which stage the trouble occurs. Starting with the output tube the signal grid of each tube is touched

(Continued on page T-28)

Television Set Owners Want Larger Pictures

Demand For Bigger Pictures Offers Lucrative Source
Of New Income For Television
Servicemen.

The honeymoon period of television is over. People in the major television areas are beginning to evaluate its real value in their lives and to decide what kind of receivers they really want. Perhaps the most significant development is the very strong trend toward larger pictures. During the early stages of commercial television, the great majority of receivers used a 10-inch picture tube.

In the past year or so 90 per cent of the television receivers manufactured used a picture tube equivalent to a 12-inch diameter or larger, and in recent months the 16-inch tubes have achieved a predominant position. The most practical size of picture tube is determined by the dimensions of the home in which the receiver is to be used. For use in small homes, in which most of us probably live, perhaps a 12-inch or a 16-inch tube provides the most satisfactory picture. In larger homes, a 19-inch or a 20-inch tube and even larger tubes which are now in the developmental stages may be the most desirable.

Experience shows that the best viewing is provided when viewer is located at a distance between three or four to about 15 times the horizontal dimension of the picture. This is slightly greater than the optimum distance for motion pictures. In a typical living room, people often sit across the room from the television receiver about 10 feet or so from the picture. This does not include the children who crowd as close as possible to the picture whenever they can get away with it. This, of course, should be strongly discouraged. With the viewers at ten feet, the picture provided by a 10-inch tube is smaller than many people would like. Thus, the demand for larger pictures is well founded on the experience of many viewers.

The interest in obtaining larger pictures has resulted in a lucrative source of income for many servicemen in replacing original picture tubes with new ones of larger size. It is theoretically possible to replace any picture tube with any other type. However, there is a very practical limit to the amount of work which can be expended in making the change. Sylvania engineers have made a study of the practical conversions which can be made profitably in the service shop and which will give the most satisfaction to the owner. There are many factors to be considered. There is the obvious problem of space. It is generally necessary to use the original cabinet.

The new picture tubes of larger size also have a larger deflection angle to reduce the overall length. This means that more power must be available for deflecting the electron beam. For these tubes new yokes and new deflection output transformers must be used. The high voltage for the second anode must

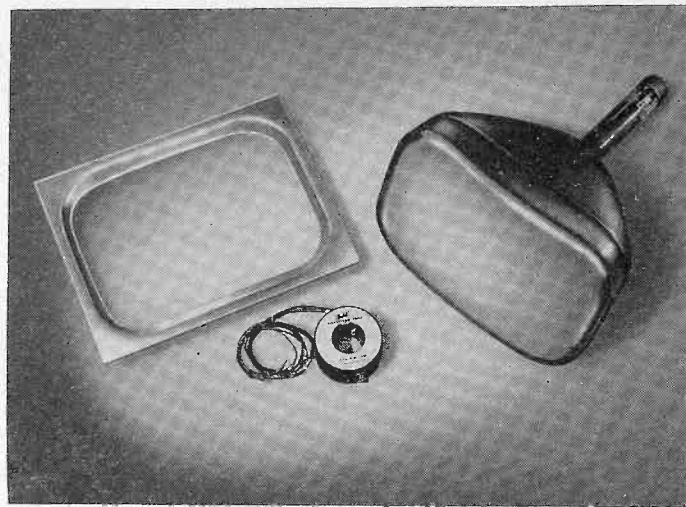

Above are three basic elements necessary for conversion of small television sets to sets with larger pictures. Left is the mask, center is the yoke and right is the Sylvania rectangular picture tube.

often be increased for the larger tubes. The operating voltages of the new tube may be different from the original tube, as well as the current through the focusing coil, and a number of resistors and condensers might have to be changed. It is also necessary that a picture tube be replaced with one of the same general structure in the electron gun. That is, a tetrode must replace a tetrode and a triode must replace a triode.

Perhaps the most satisfactory conversion is to install a Type 14CP4 picture tube in place of any one of several 10-inch types. The 14CP4 has a rectangular face on which the picture is slightly larger than that produced on a 12-inch round tube. This conversion can be applied to almost any receiver using a 10BP4, 10CP4, 10EP4 or a 10FP4, all of which have tetrode gun structures. Because of the greater deflection power requirements of the 14CP4, a new yoke of suitable design is necessary. It will be found in many receivers that a new horizontal output transformer is also necessary for fully satisfactory results. A voltage of at least 9000 volts should be available for the second anode.

If the high voltage is less than this, it is necessary to use a new horizontal output transformer with appropriate circuit changes to produce the desired voltage and deflection. This, of course, assumes a flyback type of high-voltage power supply. If an rf power supply is used and the voltage is less than 9000 volts the trimmer condenser should be adjusted to increase the output voltage. The use of an insulated screwdriver for this is imperative. If 9000 volts cannot be developed, perhaps, the oscillator tube is weak and should be replaced. Note that with the rf power supply, the voltage may be about 1000 volts higher with the cover in place. The high voltage should be measured very carefully. The Sylvania Polymeter

(Continued on page T-28)

Summer Service For Three-way Portables

(Continued from page T-26)

to produce a click in the loudspeaker. If, at one stage no click can be produced by touching the control grid lead, the defective stage is identified and the faulty part can be located with an ohmmeter or voltmeter, or the tube itself may be bad.

Tubes should not be pulled out of their sockets in making circuit disturbance tests. The filaments of the tubes are often connected in series, and when one tube is pulled out the filament circuit is broken. The electrolytic condenser used as part of the filament current filtering network will charge up to a high value and when the tube is replaced the high current caused by the high capacitance condenser discharging through the low resistance filament string may burn out the filament of the tube or perhaps of several or all of the tubes in the receiver. The same precaution must be observed when replacing a tube which had a burned out filament. Before inserting a replacement tube, the set should be turned off and the electrolytic filter condensers of the filament string should be discharged.

For optimum performance of a receiver a thorough realignment is necessary to complete the service job, particularly when replacement of rf, converter or if tube was necessary.

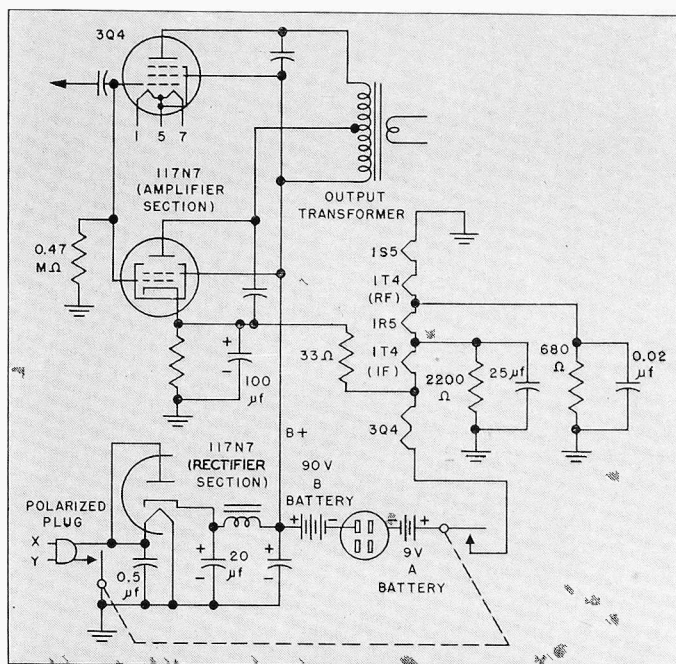

FIG. 3—In this type of circuit the audio amplifier is a low drain battery type for battery operation, and a Type 117N7 beam power amplifier and half-wave rectifier for power line operation.

Television Set Owners Want Larger Pictures

(Continued from page T-27)

with the high voltage probe is intended for measuring voltages of this order of magnitude.

Parts recommended for use in the conversion of 10-inch sets to 14-inch rectangular sets include a Sylvania Type 14CP4 rectangular picture tube, a 70° deflection yoke, such as the Todd Trans Corp. yoke Number 70P8 and a plastic mask which covers the entire face around the screen.

Many different makes of 10-inch and 12-inch receivers can be converted using these components. However, for receivers using direct drive horizontal deflection output circuits, the specifications for the correct yoke to be used must be obtained from the manufacturer of the receiver. In some cases it may also be necessary to replace the ion trap and the focusing coil with units of appropriate design so that they will fit on the neck of the Type 14CP4 which is slightly shorter than on some of the older tubes.

By using the Todd deflection yoke, No. 70P14 and a matching Todd horizontal output transformer No. 77 or their equivalents, and making appropriate changes in the horizontal drive and output circuits it is practical to replace the following 10-inch and 12-inch tubes, 10BP4, 10CP4, 10EP4, 10FP4, 12JP4, 12LP4, 12QP4, 12RP4, and 12TP4 with one of the following 16-inch or 19-inch tubes, 16KP4, 16TP4, 19AP4 and 19AP4A.

For the 16-inch tubes there should be at least 12,000 volts available and for the 19-inch tubes there should be at least 13,000 volts available. In many receivers the high voltage may be increased by slight circuit changes in the horizontal drive and output circuits.

It is important to note that when a metal-glass picture tube is used, extreme care should be exercised to prevent arcing from the metal cone, which is at high voltage, to other components and to prevent leakage to the cabinet which would present a serious safety hazard. Also, all picture tubes should be operated within their rated voltage limits. As a matter of safety a window of plastic material or safety glass should always be used in front of all picture tubes.

Because of the many differences in the circuits of the great variety of television receivers which have been sold during the past few years, only the most general direction can be given for using a larger picture tube. It may be found in some cases that it is much too costly to attempt a change. In others, all that may be necessary would be to take out the old tube and put in the new. Each receiver must be judged by itself. Before attempting to do an unfamiliar conversion job, the serviceman should be thoroughly familiar with the circuits used, the characteristics of both picture tubes in question and the changes necessary to make the new tube give completely satisfactory service.



Hi! Ho! Come To The Fair!

Local fairs and parades offer excellent opportunities for service dealers to promote their business. Inexpensive displays or floats used in parades call the public's attention to the service business and are helpful in obtaining future publicity for the dealer.

John P. Kline, of Gloversville, N. Y. took advantage of a local promotion to sell his service recently. A week-long show at the local armory offered an excellent opportunity to acquaint the public with his products and service. To open the show, a parade was held in Gloversville.

Winner of first prize in the parade was the float of Kline's Radio. Built around a South Sea Island theme, the float pictured a man in a cannibal's boiling pot watching television. The float caused plenty of comment in Gloversville, and has worked well to develop business for Klines.

Promotions such as these are important in building customer good will. Also important to Kline is the use of high quality products in servicing radio and television receivers. For accurate trouble shooting, Kline depends on Sylvania test equipment to do the job quickly

and surely. To insure lasting customer satisfaction Sylvania Tubes are used extensively in the replacement of worn out tubes.

Kline's Radio and Television Service employs five men in their shop for maintaining radio and

television sets. Through effective promotions, good test equipment and high quality replacement parts they are able to render a customer service which has helped them build their business into a growing organization.

Campaign Against TV Abuses

In an effort to reduce the growing number of complaints about television service, the New York Better Business Bureau in cooperation with television manufacturers, dealers, distributors and service companies has launched a campaign to correct such abuses.

The major purpose of such a campaign is to "reduce current faulty and misleading practices and to inform the public of basic facts they should know about purchasing and service, helping consumers to buy intelligently and reducing the volume of unjustified complaints," according to H. R. Jackson, president of the BBB.

Jackson stated that the New York BBB had received 2202 inquiries and complaints regarding radio and television during the first five months of 1950. Of these, 1263 were complaints. The total

of TV complaints received by the Bureau since January 1 nearly equals the total of all similar ones received during the entire 12 months of last year.

More than 1000 radio, television and appliance dealers from the New York area launched the campaign at a meeting on June 28. Each dealer was presented with copies of a booklet entitled "Things You Should Know About the Purchase and Servicing of Television Receivers." It contains information on interference, antennas, guarantees, servicing and general points of buying and servicing which will keep the customer out of trouble.

The booklets are available for distribution by dealers and may be obtained at a modest cost by writing to the Better Business Bureau of New York City, 280 Broadway, New York 7, N. Y.

Safety For Your Eyes With The New Protecto-Shield



Television picture tubes are not dangerous if handled with care and respect. Accidents do occur, however, so it is always better to be safe than sorry. To protect eyes and face from harmful injuries resulting from accidental breakage of TV tubes Sylvania now makes available a new protecto-shield.

The new Sylvania Protecto-Shield is a clear-view, scratch free plastic visor, which will protect both eyes and face. It is made of sturdy plastic, curved to fit around your face. The visor is easily removable for cleaning or replacing. The visor tips up when not in use. The non-metallic headband is adjustable for perfect fit, and uses a replaceable cotton felt sweatband for added comfort and protection against skin irritation.

The protecto-shield is recommended for use by television repairmen when replacing tubes in a chassis, unpacking new tubes and when destroying old tubes. It is now available from Sylvania Distributors. The price is \$3.80. Replaceable visors and sweatbands are also available at moderate cost. If your distributor cannot supply you, order from the Advertising Department, Emporium, Pa. Enclose check, cash or money order when ordering from Emporium.

Inserting Picture Tubes
Unpacking Picture Tubes



Destroying Worn-out Tubes

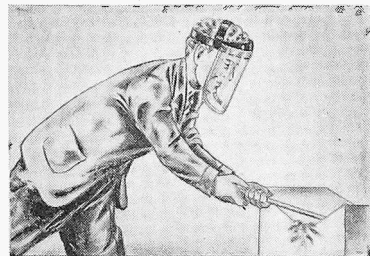

DON'T FORGET.. AUGUST 31st

is the last day you can get →

FREE

...with

100 SYLVANIA Receiving Tubes

or 3 SYLVANIA TV Picture Tubes

SEE YOUR NEAREST SYLVANIA DISTRIBUTOR NOW!

"WE DOUBLED OUR STORE SPACE"

(Continued from page M-25)

name on your mailing list. The material in this kit is supplied free. The only cost of the campaign to you is the postage on the postal cards which you mail to your prospects.

A big new campaign is now ready for September, October, November and December. Write today for more information. Address your inquiry to the Advertising Department, Sylvania Electric, Emporium, Pa. Remember Sylvania backs your own local campaign with national advertising which presells your service.

Sylvania Engineer Simplifies TV Servicing By Stressing Importance Of Visual Indications

Although a television receiver is five or six times as complicated as a radio broadcast receiver, Clarence L. Simpson, field engineer for Sylvania says that it is not necessarily five or six times as difficult to repair.

"The reason why this is so," Simpson explained, "is because the TV serviceman can see many clues to TV set faults, whereas he has to rely on his ears for similar troubleshooting in the case of the radio broadcast receiver. The picture tube reveals many basic disturbances in TV circuit operation. Once the serviceman has acquainted himself with the particular pattern that shows clearly on the face of the picture tube, he can spot trouble almost at a glance. In radio set servicing the serviceman has to rely only on his ears. In TV servicing he can use both ears and eyes."

Simpson said that numberless viewing tube screen patterns reveal set faults. These screen patterns

aid quick and positive detection of many circuit troubles which the average serviceman can promptly correct in most instances.

Picture tube screen patterns also help the TV serviceman to detect outside interference and to distinguish it from improper set operation, according to Simpson. He stressed this as an important consideration, particularly when the set is installed. Proper installation of the antenna is one of the most important considerations to assure the best possible program reception.

Simpson is a specialist in the practical maintenance of home television receivers and has addressed more than 20,000 radio and TV servicemen from coast to coast on the subject of efficient TV servicing.

Currently in his talks, which are sponsored jointly by Sylvania Electric and local distributors, he is discussing changes in TV serving techniques which help repairmen do a better job, save time, and increase profits while reducing TV mainte-



Clarence Simpson

nance costs for the set owner. In the process he explains new set design trends and makes specific suggestions for serving new types of TV circuits which are being adopted by a large number of TV set manufacturers.

Several distinct trends, according to Simpson, include modified front-end designs and the adoption of inter carrier sound systems. These developments and others during recent years have created far different problems for the TV serviceman than those encountered in the maintenance of standard broadcast receivers. For this reason Simpson believes that servicemen should consider basic points of difference between TV set and radio set servicing. During his talks he makes a step by step comparison to reduce TV sets to simplest terms and to provide practical answers for the servicing problems for all circuit components.

The program of meetings for radio and TV servicemen will continue throughout 1950 and will include sections of the country where TV programs are firmly established, fringe areas and communities where the introduction of TV signals is expected within the next few months. Your Sylvania Distributor can give you complete information about the Sylvania Service meeting program and when it will be held in your locality.



Above is a group of West Coast servicemen at a television service meeting sponsored by Sylvania. Speaker Clarence Simpson, on the stage at right, travels to all parts of the country to aid servicemen in better understanding television and TV servicing techniques.

Sylvania Develops Subminiature Photoelectric Unit

Tiny device thinner than a match stick and less than an inch long will operate relay without electronic amplification.

Laboratory development of a tiny, inexpensive photocell which utilized the photosensitivity of germanium has been announced by Dr. R. M. Bowie, manager of the Physics Laboratories of Sylvania.

"These new subminiature photoelectric devices," Dr. Bowie said, "are sufficiently sensitive so that useful current changes are obtained with relatively small changes in light intensity. It is anticipated that they will find wide use in such applications as decoding punched tape, electronic computing and sorting, and in the direct operation of relays such as for opening and closing doors. Compactness and high sensitivity should make them particularly well suited for many applications where cost, complexity of circuitry and space limitation are

important factors. In fact, one may readily visualize applications in which ordinary phototubes are entirely unsatisfactory."

He described the new photoelectric device as being essentially a germanium diode especially designed to permit use of the photoelectric properties of germanium and similar semiconductors. Experimental models have been made in which a tiny piece of germanium in contact with a fine wire or "whisker" are sealed in a solid piece of plastic about half an inch long and smaller diameter than a kitchen match. The transparent plastic, in addition to serving as a rugged sealed housing, provides an effective light path to the point at which the whisker makes contact with the germanium.

Dr. Bowie stressed the fact that these new devices are still in the laboratory stage and that plans have not been completed for quantity production.

Facts & Figures...

TV Set Production Sets Record

Television set production during the first half of 1950 equalled that of the entire of 1949, according to the RTMA. Production to July 1 totalled 3,100,000 sets. Radio production too, was up nearly 50% over the corresponding period of 1949.

RTMA member companies reported the manufacturer of 2,413,145 TV receivers in the first half of 1950 compared with 913,071 during the corresponding period of 1949. During June RTMA companies produced 388,962 television receivers.

Radio set production for the first six months of the year by RTMA member companies numbered 5,228,170 compared with 3,481,858 in the first six months of last year. The radio set production included 1,377,458 auto sets and 1,034,458 portables.

On The Cover

Electron gun mounts and finished glass bulbs for television picture tubes are sealed together on automatic rotary machines at Sylvania's Ottawa, Ohio plant. The operator on the cover is removing an assembled tube which is ready for automatic exhaust and processing. The overhead conveyor system shown in the foreground speeds the handling of picture tubes. The conveyor system in Sylvania's Ottawa plant is more than a mile long.

In This Issue

NEWS

REPORT ON COLOR TELEVISION

MERCHANDISING

"WE DOUBLED OUR STORE SPACE"

TECHNICAL

SUMMER SERVICE FOR THREE-WAY PORTABLES

SYLVANIA NEWS

SYLVANIA ELECTRIC PRODUCTS INC.
P. O. BOX 431
EMPORIUM, PENNA.

Sec. 34.66, P. L. & R.

U. S. POSTAGE

PAID

Permit No. 1
Emporium, Pa.

For:

J. A. Renville
163 Main St.
Luzerne, Pa.

A

POSTMASTER: IF UNDELIVERABLE FOR ANY REASON, NOTIFY SENDER, STATING REASON, ON FORM 3547, POSTAGE FOR WHICH IS GUARANTEED.

Vol. 17, No. 7

AUGUST, 1950

PUBLISHED BY
SYLVANIA ELECTRIC PRODUCTS INC.

MANUFACTURERS OF SYLVANIA RADIO TUBES, CATHODE RAY TUBES, ELECTRONIC DEVICES, FLUORESCENT LAMPS, FIXTURES, WIRING DEVICES, ELECTRIC LIGHT BULBS, PHOTOLAMPS, RADIO AND TELEVISION RECEIVERS

SYLVANIA NEWS

BOB PENFIELD, Editor

SEPTEMBER 1950

VOL. 17, NO. 8

Copyright 1950, Sylvania Electric Products Inc.



Sylvania TV Show To Plug Radio-Television Service

One of the most important steps ever taken by Sylvania to promote their dealers and products is the purchase of a half hour television show over the CBS television network. The Sylvania show called "Beat the Clock" is an audience participation show which will first be broadcast on September 29.

Present plans call for broadcast of "Beat the Clock" in 22 television markets. Additions to the present schedule will be made as soon as time clearance can be obtained.

Stations slated to broadcast the show and the time for each city is listed below.

Station	City	Time PM
WCBS-TV	New York	10:30 Fri's
WAGA-TV	Atlanta	10:30 Fri's
WMAT-TV	Baltimore	10:30 Fri's
WBTW	Charlotte	10:30 Fri's
WBKB-TV	Chicago	11:00 Wed's

WKRC-TV	Cincinnati	10:30 Fri's
WBNS-TV	Columbus	10:30 Fri's
WFMY-TV	Greensboro	10:30 Fri's
WMBR-TV	Jacksonville	10:30 Fri's
WHEN-TV	Syracuse	10:30 Fri's
WTOP-TV	Washington, DC	10:30 Fri's
KTTV	Los Angeles	10:30 Fri's
KPIX	San Francisco	10:30 Fri's
WHIO-TV	Dayton	11:30 Fri's
WJKB-TV	Detroit	7:00 Sun's
WCAU-TV	Philadelphia	11:00 Sat's
WXEL-TV	Cleveland	7:00 Sat's
WTCN-TV	Minneapolis	10:00 Fri's
WAFM-TV	Birmingham	9:30 Fri's
WNAC-TV	Boston	8:30 Tues's
WHAS-TV	Louisville	10:10 Fri's
KING-TV	Seattle	11:00 Fri's

"Beat the Clock" is emceed by Bud Collyer. It has had a very successful run during the summer months. It is a fast moving, hilarious quiz show in which participants—usually husband and wife—are asked to do amusing parlor tricks within a predetermined number of seconds.

Sylvania Announces New, Improved Cathode Ray Oscilloscope

A new 7-inch cathode ray oscilloscope which has been specially designed for general use in radio and television receiver testing and in laboratory and production applications has been announced by Sylvania.

The new instrument, Type 132Z, incorporates a multivibrator sweep circuit for linear internal sweep from 10 to 30,000 cycles which may be synchronized to 60 cycles, an external signal or signal applied to its vertical input terminal. Balanced, non-astigmatic sweep is assured by push-pull deflection. Terminals are provided for direct connection to horizontal and vertical deflection plates and to the control grid of the cathode ray tube for intensity

modulation.

The vertical deflection amplifier provides a sensitivity of .1 volt rms for one inch peak-to-peak deflection; sine wave frequency response at full gain flat within 3 db of 1000 cycles value from 7 to 70,000 cycles free of peaking and useable to much higher frequencies; and an input impedance of $\frac{1}{2}$ megohm and $34 \mu\mu$.



Oscilloscope Type 132Z

The horizontal amplifier provides a sensitivity of at least .25 volt rms for one inch peak-to-peak deflection; sine wave frequency response within 3 db from 7 to 120,000 cycles; a total deflection of at least $8\frac{1}{2}$ inches with negligible distortion; and input impedance of $\frac{1}{2}$ megohm and $34 \mu\mu$.

Horizontal sweep characteristics

This program has been recommended over all other types of shows because it offers an excellent opportunity for faster product identity without dull stereotyped commercials typical of many TV shows.

During the show all of Sylvania products will be plugged. Radio and Television Servicemen will be featured in many of these commercials and the Sylvania RADIO TELEVISION SERVICE decal will be promoted as the sign of dependable service for all makes of radio and television sets.

"Beat the Clock" will help complete the extensive efforts of Sylvania for dealers in their coordinated advertising campaign. It will help sell service—Sylvania dealer's service—to 55% of the radio tube market and 85% of the television service market.

Dealers in the areas covered by the broadcast will find value in tying in their service business with the "Beat the Clock" show.

include: linear (multivibrator) sawtooth sweep, left to right, from 10 to 30,000 cycles; non-linearity not exceeding 10% between rated limits at any sweep frequency; and response to positive synchronizing signals.

Sylvania Oscilloscope Type 132Z is $17\frac{1}{16}$ " high, $11\frac{3}{8}$ " wide, $17\frac{3}{4}$ " deep and weighs 39 pounds. Steel cabinet is provided with grey wrinkle finish and $\frac{1}{8}$ " clear safety glass disc to protect 7" CR tube face. Cross-hatching is provided on a plastic sheet inserted behind the safety glass to minimize parallax. New, jet-black panel lettering on a grey background gives added contrast for easy reading of control settings under both normal and adverse lighting conditions. This instrument operates from 117 volt, 60 cycle supply and is rated at 35 watts. It is available from authorized Sylvania Distributors.

ON THE COVER

Pirate June Kosash stole the show and the hearts of those in attendance at the NEDA convention in Cleveland recently. June passed out keys to the Sylvania Treasure Chest. Lucky winners whose keys opened the chest won valuable prizes.

SYLVANIA NEWS

SEPTEMBER 1950—VOL. 17, NO. 8

COPYRIGHT 1950
SYLVANIA ELECTRIC PRODUCTS, INC.

Merchandising
Section

ADVERTISING

Any Service Business Can Afford Good Advertising . . . No Service Business Can Afford to Be Without it . . . Producers Are Anxious to Supply Your Needs . . .

By FRED HARVEY

Reprinted from RADIO & TELEVISION MAINTENANCE

Six million television sets have made changes. They have changed America's living room, her school room and the neighborhood theater. They have also changed the serviceman. Like it or not, he has had to become a bigger businessman. To service TV, his inventory has become greater, his equipment more costly, his knowhow broader, his charges higher. His profits should have grown, too. If they haven't, he must look at his advertising program or lack of it.

With the stakes higher, the serviceman can no longer afford to advertise only when business is bad or when the whim strikes him. His program must be planned on an annual basis. Its cost must bear a direct relationship to desired service business. It must consider all the practical means of reaching prospects in his trading area—store identification material, newspaper and telephone directory ads, direct mail postal cards and mailing pieces, radio spot announcements, and the many forms of "reminder" sales promotion.

Consistent Program Needed

All of these means must be used by the service dealer constantly and consistently to accumulate an impression on the prospect's mind. If such an advertising program is planned and executed properly, there should be no need for frantic last-minute selling at that critical moment when the prospect's set needs service. The impression—and the sale—will be made . . . and so will the profit.

The first step in drawing up an advertising program is the toughest.

It's the decision to spend for advertising. Apparently, this money could go into the serviceman's pocket as profit. He asks himself, "Why throw it away on advertising?" To answer this question, the serviceman need only look at his successful business neighbors—large and small, and—by all means—at his competitors. Are they spending for advertising? Is it paying off? The answer in 90 per cent of the cases will be "Absolutely!"

Five Percent of Gross

Both large corporations and smaller businesses spend varying amounts on their advertising programs, depending on their marketing problems. A good rule of thumb for the radio or television serviceman, however is, "Set aside five per cent of your gross service income for advertising." Suppose a service shop owner plans to do a \$6,000 service business during the coming year. Five per cent of that is \$300—let him set it aside on paper and budget his program around that figure.

Once the decision to spend that \$300 has been made, the big problem is "How can I plan a complete and adequate year's campaign for my \$300?" Typical store identification and "point of sale" advertising for a service dealer should include seasonal window and counter displays and window streamers, permanent store signs and daily eye-catchers such as thermometers and clocks advertising "Radio and Television Service." Most important items in a serviceman's advertising campaign are the means of directly soliciting prospects' business—ad-

vertising postal cards and mailing pieces, mailed regularly. In addition, a well-rounded program should include telephone directory listing, occasional newspaper ads and a varied group of sales promoting reminders, such as stationery, bill heads, business cards, service stickers, advertising match books, and doorknob hangers.

For an average radio serviceman to try to design and have printed even a minute fraction of his material would consume more than his \$300 overnight.

Manufacturers Help

Fortunately, the manufacturers of radio and television parts are as interested as the serviceman himself in increasing radio and television service business. It means more sales for them. Consequently, many of them, particularly radio tube manufacturers, maintain a complete line of expertly-created and proven advertising material for the service dealer, buying it in huge quantities and reselling it to the serviceman at cost or giving it to him free. Much of this material is available with the individual service dealer's name, address and phone number prominently printed on it.

The service dealer will find that his \$300 or 5 per cent of gross sales will buy a complete and adequate advertising program if it is budgeted against a parts manufacturers' catalog of advertising aids. One tube manufacturer, Sylvania Electric Products, Inc., not only provides its radio and service dealers with a complete local advertising campaign, but backs up these campaigns with thousands of dollars of advertising in popular national magazines. These ads urging set owners to "call the dependable serviceman who displays this sign" and reproduce in the ads the store identification decals Sylvania provides free to its dealer customer.

Complete Campaign Available

Also free to dealers is a complete four-month advertising campaign containing two large four-color three

(Continued on page M-31)

for this band are low power and readily removed by use of a wave-trap.)

An exhaustive study of the situation by a committee by RTMA has shown that the use of a 44 mc if would eliminate the most prevalent defects of the old standard. The essentials of this are shown in Table 1 which gives the oscillator frequency for two separate cases:

1. For the oscillator always above the signal frequency.
2. For the oscillator above signal frequency on channels 2 - 6 and below on channels 7 to 13.

It is apparent from the table that there is no oscillator radiation interference problem between receivers using the new 44 mc if, nor is there any image reception from FM stations possible if the oscillator is always put above the signal frequency. When image interference is encountered it will be of less degree due to the higher if.

A further advantage of the 44 mc if is that it is suitable for the proposed UHF TV bands. Receivers capable of covering both the present 12 channels and the proposed new UHF channels can be designed using a common if. By proper allocation as suggested by a committee of the RTMA, the freedom from oscillator radiation interference to the 44 mc if can be extended into the entire UHF band. If the TV service is to be expanded into nationwide coverage, it will be necessary to go to the UHF band to obtain the frequencies required. Forty-two additional 6 mc TV channels have been proposed extending from 469 to 721 mc.

The advantages obtained by going to the higher if are not obtained without some difficulty. The tendency for instability is about 35 percent worse for the 44 mc if. The problem of obtaining sufficient

TABLE 1
INTERFERENCE OBTAINED WITH 44 mc IF SYSTEMS COMPARED
WITH FORMER 24 mc STANDARD

TV Channel	Picture Carrier Frequency	Sound Carrier Frequency	Receiver Oscillator Frequency		
			(IF Sound Carrier 21.25 Mc)	(IF Sound Carrier 41.25) For all 12 Channels	(IF Sound Carrier 41.25 on Channels 2-6 Channels 7-13)
2	55.25	59.75	81.0 (a)	101.0 (d)	101.0 (d)
3	61.25	65.75	87.0 (b)	107.0	107.0
4	67.25	71.75	93.0	113.0	113.0
5	77.25	81.75	103.0	123.0	123.0
6	83.25	87.75	109.0	129.0	129.0
7	175.25	179.75	201.0 (c)	221.0	132.5 (e) (f)
8	181.25	185.75	207.0 (c)	227.0	138.5 (f)
9	187.25	191.75	213.0 (c)	233.0	144.5 (f)
10	193.25	197.75	219.0	239.0	150.5 (f)
11	199.25	203.75	225.0	245.0	156.6
12	205.25	209.75	231.0	251.0	162.5
13	211.25	215.75	237.0	257.0	168.5

NOTES:

- (a) May cause interference to channel 5 due to oscillator radiation. May receive FM stations on image frequency.
- (b) Oscillator radiation on channel 6.
- (c) Oscillator radiation on channels 11, 12, 13 respectively.
- (d) Image interference may be encountered from 144 mc amateurs.
- (e) Image interference from channel 6 may be encountered.
- (f) Image interference from FM may be encountered.

rejection at the trap frequencies is more formidable. The stability problem is greatly simplified if the method of intercarrier sound reception is used, since no narrow band sound if stages at 41.25 mc are then required.

The feasibility of the new if has already been shown and a few manufacturers have already introduced receivers using 44 mc as the intermediate frequency.

Complements of the Sylvania type 6AU6, 6BC5 and 6CB6 tubes have been used in these if strips, which are of the stagger-tuned design. Circuit-wise they are little different from the older 24 mc designs. As the converter, Sylvania types 6AG6, 12AT7 and 6J6 tubes have been used. The alignment procedure is quite similar to that used with the lower frequency amplifiers, though short leads from the signal generator are even more important than heretofore.

These high if receivers have won ready acceptance, both from the public and their manufacturers, as being more free of direct if pick-up interference than former models using the lower if. The outstanding achievement, that of producing no oscillator radiation interference, is somewhat less apparent to the owner, however, as he does not directly see a benefit from this feature other than being assured that he is not spoiling the TV reception of his immediate neighbors. By the same token, other similar receivers installed in his immediate area will not bother his viewing. To fully realize the benefits of this feature, all sets must be built with the 44 mc if. This will undoubtedly come about eventually just as the old regenerative detector was replaced by the neutrodyne, and later by the superheterodyne in the early days of broadcast receiver design.

REVISED ISSUE OF RECEIVING TUBE CHART

There's a brand new revised issue of the Sylvania Receiving Tube Characteristics Chart waiting for you at your Sylvania Distributor. Over 100 additional tubes have been added, bringing the total covered to 675. Several recently announced Germanium Diodes have also been added to bring that table right up to date.

As in the last issue the tube basing diagrams are shown immediately under the type to which they refer—the way you like them.

Your FREE copy is available from your local Sylvania Distributor, or by request from the Advertising Department, Sylvania Electric Products, Inc., Emporium, Pennsylvania.

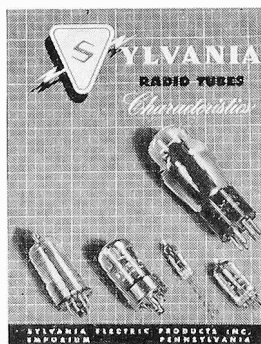

AN IMPROVED TEST FOR TYPE OZ4 TUBES

Anyone who has serviced automobile receivers has had trouble with Type OZ4 rectifiers. Now a means has been developed which enables better testing of the OZ4 tube to show the performance that may be expected in a particular automobile receiver.

Servicemen know that different voltages are applied to OZ4 rectifiers in various receivers, and that this voltage is subject to considerable variation depending on the automobile generator and condition of the battery. Not so widely known is the fact that among OZ4's, there is considerable variation in the voltage at which the tube will ionize or begin to conduct, and that this "firing" voltage may vary with the amount of service that the tube has given. Most servicemen are familiar with complications such as the OZ4 that fails in a tube tester, but operates in a receiver. Sometimes the opposite occurs, and an OZ4 tests GOOD, but will not operate in a particular set. Some OZ4's test GOOD and also operate satisfactorily in the shop, but later appear to become intermittent in the customer's automobile. The latter situation is most likely to occur in automobiles with less effective voltage regulators and questionable batteries.

Heretofore, it has been difficult, if not impossible, for a serviceman to evaluate OZ4's as to the voltage at which they "fire." Tube testers

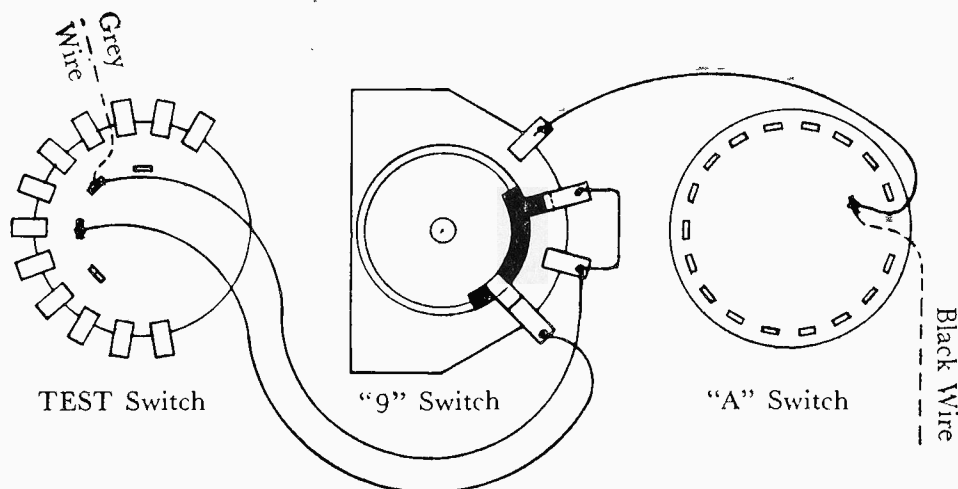

have employed a test voltage which either assured that any OZ4 testing GOOD would work in almost any receiver and automobile, and thus tended to reject many tubes which would have been quite satisfactory, or conversely, tended to pass OZ4's that would not perform in those circuits where the voltage is low for any reason. Now, using Sylvania Tube Testers Types 219 or 220, it is possible to make both a normal and a high-voltage test of OZ4's, thus permitting selection of tubes for applications where the voltage is suspected of being low. At the same time, tubes which operate satisfactorily with a slightly higher voltage need not be rejected and wasted; rather may be used in applications where the receiver supplies a higher voltage. Owners of Sylvania Type 219 Tube Testers with serial numbers up to and

including 10100 or Type 220 up to and including 20655 may make the modification which makes it possible to test OZ4's under two conditions. Details for making the modification are shown below. Testers with higher serial numbers have the modification incorporated at the time of manufacture.

After the modification has been made, it is possible to test the ionization or "firing" voltage of the OZ4 up to a maximum of 327 volts (457 volts peak). The original test as stated on the roller chart can still be used. A very good OZ4 will fire on the regular test, and a passing OZ4 may be regarded as safe to use for any application. However, any tube which does not ionize on the added, high-voltage test is unsatisfactory for even circuits where the voltage is high, and should be discarded.

HOW TO MAKE THE MODIFICATION

1. On the TEST switch, cut out the bare wire jumper between #2 and #3 moving arm lugs, which are on the side of the switch toward the C/F switch bank.
2. A grey wire is soldered to the #3 moving arm lug. Leave this grey wire connected, and connect a new wire from this same point to the #2 lug on the side of the 9 switch nearest the TEST switch. (Lugs #2 and #3 on the 9 switch are connected together with a bare wire jumper, on some tube testers.)
3. There must be a connection between lugs #2 and #3 on the 9 switch, but on some tube testers it will be found that an additional bare wire lead goes across to the other side of the 9 switch, to the #3 lug on the other section. This lead must be cut out for this modification.
4. There is now one moving arm lug on the TEST switch which has nothing connected to it, since the bare wire jumper was removed in step 1. Run a wire from this lug to the #1 moving arm lug on the 9 switch (same side of 9 switch as before).
5. Connect a wire from the #4 lug of the 9 switch (same side as before), to the moving arm of the "A" switch. The moving arm lug of the "A" switch is a lug coming out of the bottom of the switch, to which a black wire is connected. Do not disconnect this black wire.

After completing this modification, check carefully against the drawing before plugging the tube tester in or turning it on.

Settings

After making this OZ4 modification, the complete test will be:

A	B	C	D	E	F	G	K
		HIGH VOLTAGE TEST					
117	4	-	5	4	9Z	3**	
"	"	-	5	4	9Z	5**	
		REGULAR TEST					
0	-	1	11	-	Z	3**	
"	"	1	11	-	Z	5**	

**Gas Test does not apply.

SYLVANIA CATHODE RAY TUBE TEST ADAPTOR

Standard procedure for testing television picture tubes today consists of the old-fashioned substitution method. That can all be changed if you own a Sylvania Tube Tester Model 139, 140, 219 or 220 and a Sylvania 228 CR Tube Test Adaptor. With this combination, all of the commonly used 10 to 19 inch magnetic types can be checked.

By placing your Sylvania tube tester close to the chassis, the picture tube need not be removed from the cradle—a real time saver in many sets. After making sure the set is turned off, the adaptor is plugged in according to the instructions with the unit and settings determined from the accompanying card. Since only a few hundred volts are available, as compared to 10,000 or more in the receiver, comparative readings are taken from the small numerical scale rather than on the "GOOD-BAD" scale.

There are a few picture tube defects, such as gas, that show up only with high voltage, but this tester will determine 85% of cases where the picture tube should be replaced. Shorts, leakage, open circuits, and relative emission are easily determined. Most other defects, such as a damaged screen coating, can be determined by observing the picture.

The socket provided is the almost universal duodecal. Test settings are provided for such popular tubes as 10BP4, 10FP4, 12KP4, 12LP4, 14BP4, 14CP4, 16AP4, 16GP4, 16JP4, 16LP4, 16RP4, 16TP4, 19AP4 and any A or B versions of these.

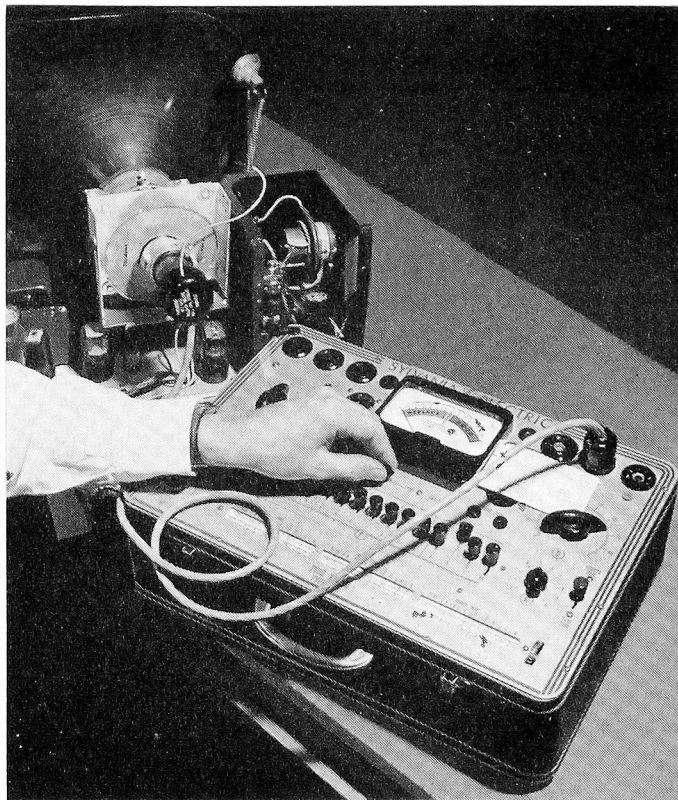

NEW SETTINGS FOR TYPES 139 AND 140 TUBE TESTERS

To obtain the best use of the Type 139 and 140 Sylvania Tube Testers the following revised test settings should be incorporated in Chart No. 15845-E. The number may be found in the lower left hand corner of the chart. If your tube tester does not contain this latest chart, it may be purchased from the Advertising Department, Sylvania Electric Products Inc., Emporium, Pa. The price is \$1.00 postpaid.

Types 139 and 140 Tube Testers

Chart E—Revision 1

	A	B	C	D	E	F	G	TEST
1C3.....	1.4	2	64	4	1	8	20	V
"	"	2	24	4	5	8	20	V
1V2.....	0.75	0	234679	0	4	-	44	V
6AQ7GT.	6.3	0	78	1	3	3	83	W
"	"	"	"	"	1	-	55	T
"	"	"	"	"	4	-	55	T

	A	B	C	D	E	F	G	TEST
6AU5GT.	6.3	0	—	0	3	57	23	Y
6AV5GT	6.3	0	—	0	3	57	21	Y
6AX5GT	6.3	0	—	0	1	—	23	Y
"	"	"	—	0	3	—	23	Y
6BF5....	6.3	0	4	0	4	36	18	W
"	"	"	3	0	4	46	18	W
6BN6...	6.3	0	—	0	3	25	48	V
"	"	0	—	0	3	056	35	V
6CB6....	6.3	0	—	0	4	36	60	W
6CD6G..	6.3	0	—	0	8	47	20	Y
6R8.....	6.3	0	6	0	4	9	62	X
"	"	"	6	0	3	—	50	T
"	"	"	7	0	2	—	50	T
"	"	"	6	0	1	—	50	T
6S4.....	6.3	0	2679	0	4	4	39	Y
6U4.....	6.3	0	7	1	3	—	19	Y

It's In The BAG!

Screws, bolts, knobs and other necessary parts of radio and television sets have a habit of disappearing from the service bench while a set is being serviced. One of the best solutions to this problem is a small cloth bag in which these parts can be stored while the set is undergoing repair.

Now available to service dealers from Sylvania is a new four inch by six inch parts bag created especially for such a job. The new Sylvania parts bags have the added feature of an attached job ticket. The new bag is equipped with a draw string, too. No danger of losing knobs or screws when you use a Sylvania parts bag and job record.

Drop the screws and parts into the bag, draw the string up tight, tie it to the chassis or cabinet. When the set is repaired, put the knobs back on the set and return the bag with defective parts to the

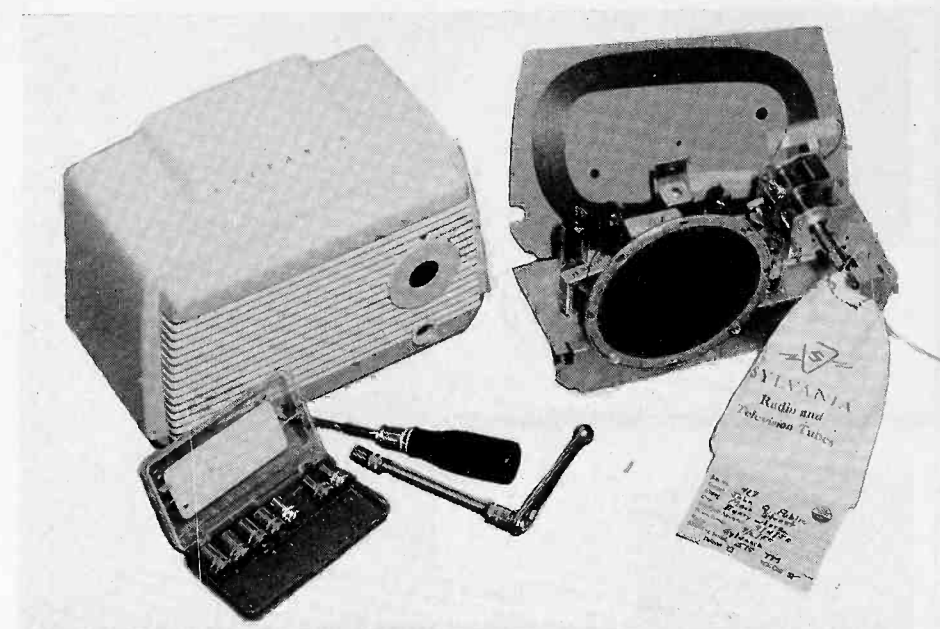

Use of the new Sylvania parts bag is illustrated above. Knobs, chassis screws, and other small parts can be stored in the bag while the set is undergoing repair. Parts bag also has attached job ticket for record keeping and customer receipt.

owner. The attached tag will be his statement of work done and receipt for the job.

The new Sylvania parts bags are now available from your Sylvania Distributor or from the Advertising

Department in Emporium, Pa. Price of the bag is \$1.50 for 50 bags or \$2.75 for 100. Order a supply today. They will save you time and headaches . . . and impress your customers.

Good Advertising

(Continued from page M-29)

dimensional window displays, two four color counter cards, two large window streamers, two sets of two and four column ad mats for telephone directory and local newspaper use, a set of four different imprinted three-color advertising postal cards and four booklets of radio spot announcements. All of the material ties in with the national ads by utilizing the same Russell Patterson cartoons of humorous radio servicing situations and the same "Authorized Dealer" decals as appear in the ads. Servicemen have to pay only a penny apiece for the postage on the advertising postal cards. All the rest of the campaign material is provided free.

Utilizing such a manufacturer's offer, the \$6000 service dealer with a \$300 advertising budget for the year can circularize a mailing list of 400 prospects 12 times a year for only \$48 for the year. If he does not care to take the time to address the cards himself he can have the work done by a local typist for

approximately \$5 per thousand or \$25 for the year. If the serviceman is located in a village or small city, he can buy space to run his newspaper ads and reserve spot announcement time from local radio stations at similarly reasonable fees.

With the money remaining, the technician can again go to the parts manufacturer for business stationery at \$5 per thousand for both letterheads and envelopes; business cards at \$2 a thousand—all of which are imprinted with store name, address and phone number. He can get from many parts manufacturers or their distributors a complete professional window valance installed on all his shop windows with his own store name in permanent three-color display for \$10. He can buy three-color fluorescent hanging signs for \$7.50, electric clocks for \$9.50, metal signs for \$1.25 and uniforms, tool kits, or service kits for less than \$10.00 each. In short, he can find an answer to every one of his advertising needs at prices far below

what it would cost him to do the job independently.

Thus spent, the serviceman's \$300 advertising budget will give him a complete advertising campaign, expertly designed to bring him increased business.

BUSINESS BUILDER

The smallest advertising budget of any radio or television serviceman can be no more effective and wisely spent than on the Sylvania Coordinated Advertising Campaign. This campaign is a complete package of specially prepared material for use in selling service. The campaign kit is available free to servicemen. The only cost in utilizing this hard hitting campaign in your own locality is the price of the one cent government postage on the postal cards.



Polymeter
Type 221

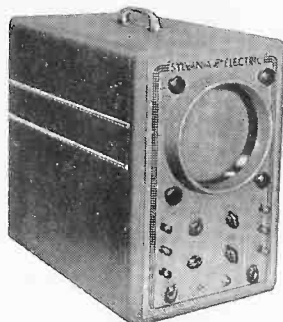

Oscilloscope
Type 132Z



Sweep
Generator
Type 500



Abe Tepper, serviceman for Dynamic Stores in New York, checks a television set for trouble spots. Sylvania Test Equipment shown on the bench is one of Abe's best friends. These instruments help him work quickly and surely.

There's Money For You In Good Test Instruments

One of the largest retailers of radio and television sets in New York City is the Dynamic Stores. As a natural supplement to the sale of receivers is the maintenance of an extensive service department.

Like any other service organization, Dynamic knows that an efficient service department is one which uses up-to-date equipment to speed up work and increase the effectiveness of their repair jobs. Good, accurate servicing of radio and television sets eliminates customer complaints, speeds delivery time of sets to customers, and increases the profits from this phase of the business.

To aid in fulfilling the job of making the service department more

profitable, Dynamic depends on good test equipment to help furnish short cuts in service. By depending on high quality test equipment for servicing of both radio and television sets, Dynamic saves time and money.

Some of the most valuable pieces of equipment used by Dynamic are Sylvania test instruments. In all, Dynamic uses three Sylvania Sweep Generators, two Polymeters, and a new Sylvania Oscilloscope Type 400. All of these instruments rate high with the servicemen at Dynamic.

One of the most popular of these instruments in servicing television sets, according to Bill Brenner, head of the service department, is the Type 500 Sweep Generator. "We

all like this sweep generator," says Bill, "because it is so compact. We think it does the best job of any similar instrument in the field and its low price is a good point in its favor."

No service organization, large or small, can afford to be without good testing equipment. By saving time in locating trouble, good test equipment speeds service work and puts more money into the pocket of the technician.

Check with your Sylvania Distributor and ask him to show you the line of quality instruments made by Sylvania. You'll be convinced that good test equipment will help you make more money when you see how simple it is to operate this equipment.

W h e e - e - e ! !

By H. E. "Rube" Ruble

SREPCO Inc.

Reprinted from SREPCO NEWS

"Hey, Joe, Television puts us in Business!" Unless my memory is poor, things were never like this in the radio service business. Technical development coming so fast that we have to burn the midnight oil even to stay in the race. The public so eager to try and to enjoy this new field that the saturation of the market in two years is fantastic.

It is now apparent that these new 20 to 40 tube super wonders may require some maintenance. The first man to try his hand at this repair is the hardy old radio service man. He has found familiar looking parts in these machines, though many of them function in strange ways. The old familiar testing does not always disclose the trouble and by many good sound reasons the things shouldn't work at all. Tube plates at chassis potential—grids driven positive several volts—grids directly grounded—plate input 250 volts—oscillator output 9000 volts! (Must be perpetual motion!)—25-tube AC-DC sets. The multiplicity of wire and cable makes a full-blown spider web look like a straight, simple line. Intermittents to drive you bats! While the customer is calling you every hour to question your progress and you don't know how you are making out yourself, some other guy calls up, burning the wires—he is waiting to pay you \$100 for a deluxe antenna and rotator so he can get a new station in Milwaukee.

If you are not driven crazy by the phone, you may be able to do a lot of profitable business.

There are some rough days ahead, however. The customers are impatient. Want service *today*. It's all very well to say they have to wait while there is such a shortage of technicians, but it will surely be held against you later when there are more men trained. We urge you to do the very best you know how with public relations, as well as technically. There is such a shortage of skilled men now that if you are able to perform intelligent repair, spend all your available time at it. Sub-contract your roof-climbing to a steeple jack or carpenter or plumber. Train a man to install and adjust and teach the customers to operate the set.

Keep using your skill to its fullest extent. You will be able to turn out more jobs, make more new customers, and create a solid foundation for a good business.

New Test Adapter For TV Tubes

Testing of television picture tubes without having to remove them from the television receiver is now possible, using a new cathode ray tube testing adapter in conjunction with any standard Sylvania Tube Tester, according to an announcement by H. H. Rainier, manager of distributor sales for Sylvania.

F C C Reports On Color T V

The FCC has granted tentative approval to the Columbia Broadcasting System's color television system. Final standards for color television have not, however, been adopted by the Commission.

Although the Commission's ruling strongly favors the CBS system over other methods of color broadcasting, it is generally believed that color television for the public is a long way off.

In announcing their decision, the FCC said that the other color

systems under consideration fall short of the Commission's criteria for a TV color system. The Commission has, however, given manufacturers until December 5 to come up with something better in the way of a color system.

Regardless of the ultimate color decision, the decision to produce color television sets will be up to the manufacturers. The current scarcity of materials indicates that it may be a long time before actual working color sets can be put on the market.

Rectangular Picture Tubes 47% of July Sales

Rectangular TV picture tubes accounted for 47 percent of the July cathode ray tube sales to set manufacturers, according to member company reports to RTMA. RTMA statistics were broken down for the first time in July to show TV picture tube sales of circular and rectangular tubes separately and to give additional data on sales of tubes larger than 14 inches in size.

Due to the vacation shutdown of manufacturing plants, July sales of cathode ray tubes to set manufacturers dropped 40 percent below June sales. Picture tube sales to manufacturers totalled 341,940 units valued at \$9,133,745 in July compared with 566,942 tubes valued at \$15,054,810 in June.

Eighty-four percent of July tube sales to manufacturers represented cathode ray tubes of 16 inches and larger in size. Picture tubes 15 inches and less accounted for only 15 percent of the July sales while tubes 19 inches and larger amounted to slightly more than 11 percent.

The new Sylvania Cathode Ray Tube Testing Adapter Type 228 is designed to indicate shorts, leakage and open heaters in electro-magnetic cathode ray tubes and will also indicate relative emission of types having accelerating anodes. In addition, when used with the Sylvania Tube Testers Type 219 and 220, heater-cathode leakage may be checked.

"It is estimated that approximately 85% of the causes of failure or erratic operation of cathode ray tubes may be detected by this simple adapter," according to Rainier. He also stated that the adapter will save television servicing time since set troubles caused by the picture tube can be isolated more rapidly.

The adapter provides the radio and TV servicemen with an inexpensive tube tester accessory which permits quick, convenient checking of TV picture tube operation. The adapter is available from Authorized Sylvania Distributors.

FRSAP Holds Outing To Climax Four Years Growth



Enjoying a lighter moment is the Federation of Radió Servicemen's Associations of Pennsylvania. The group met at Lily Lake, Pa. recently for their fourth annual Clambake.

Host at the meeting was the Radio Servicemen's Association of Luzerne County (Pa.) Officers of the Pennsylvania Organization are Dave Krantz, John Rader and Leon Helk.

Facts & Figures...

Record Set Production in August Indicated

The weekly RTMA estimates of the industry's production of radio and television receivers indicate a record level was attained during August. RTMA estimated that 514,396 TV and 906,507 radio receivers were produced during the first three weeks of the month.

The latest estimates show that 179,032 TV sets were produced during the week ending August 18; 175,609 in the week of August 11 and 159,755 during the week ending August 4. The weekly radio set estimates were as follows: August 18—299,689; August 11—330,554; and August 4—276,264.

Dealers Received 2.6 Million TV Sets in Six Months

Television dealers throughout the country were shipped an estimated 2,612,000 TV receivers in the first six months of this year, according to an industry estimate released today by RTMA. The RTMA estimate includes shipments to dealers by counties of both members and non-members of the Association.

The estimate of television receiver shipments covered 38 states and the District of Columbia. RTMA TV production estimates showed a total of 3,114,000 sets manufactured during the same six-months period. The difference of 503,000 sets represents manufacturers' and distributors' inventories and sets in transit.

Shipments in the month of June totalled 289,000, a decrease from the 369,000 TV sets shipped to dealers in the preceding month.

SYLVANIA NEWS

SYLVANIA ELECTRIC PRODUCTS INC.
P. O. BOX 431
EMPORIUM, PENNA.

Sec. 34.66, P. L. & R.
U. S. POSTAGE

PAID

Permit No. 1
Emporium, Pa.

J. A. Renville
163 Main St.
Luzerne, Pa.

For

A

POSTMASTER: IF UNDELIVERABLE FOR ANY REASON, NOTIFY SENDER, STATING REASON, ON FORM 3547, POSTAGE FOR WHICH IS GUARANTEED.

Vol. 17, No. 8

SEPTEMBER, 1950

PUBLISHED BY
SYLVANIA ELECTRIC PRODUCTS INC.

MANUFACTURERS OF SYLVANIA RADIO TUBES, CATHODE RAY TUBES, ELECTRONIC DEVICES, FLUORESCENT LAMPS, FIXTURES, WIRING DEVICES, ELECTRIC LIGHT BULBS, PHOTOLAMPS, RADIO AND TELEVISION RECEIVERS

In This Issue

NEWS

SYLVANIA TV SHOW TO PLUG
RADIO - TV SERVICE

MERCHANDISING

GOOD ADVERTISING

TECHNICAL

44 MC IF CIRCUITS FOR
TELEVISION

SYLVANIA NEWS

OCTOBER * NOVEMBER
1950

AN OPEN LETTER TO RADIO SERVICE DEALERS

SYLVANIA

ELECTRIC PRODUCTS INC.

EMPORIUM • PENNSYLVANIA

First of all, we want to thank all of you good service dealer friends for your loyalty and cooperation.

Here are the FACTS: Even before the Korean trouble, the increasing demand for Sylvania Tubes was keeping our factories on round-the-clock production schedules. With the meteoric growth of television, still greater production facilities were needed.

Since the Korean war a flurry of buying by industrial customers and the service industry alike, soon reduced warehouse and factory stocks to an all-time low.

Here's how Sylvania protects you now: To make certain that all of its regular service dealer customers are protected in this period of limited supply, Sylvania has effected a three-fold program of protection.

1. Production facilities have been greatly increased. Two additional plants have already been placed in operation. Another is under construction.
2. Your Sylvania radio and television tube suppliers are now being taken care of on an allocation plan, which we feel is established on the fairest possible basis.
3. Sylvania will continue to supply you with complete technical information for your service work, including latest data on substitution of available types for critical types.

Sylvania realizes that in the months ahead the whole country will depend upon you service dealers to keep its radios, TV sets and communications equipment in top working order. Your Sylvania Distributor will not have all the tubes you want but will do his best to serve you. We feel a deep obligation to give you the greatest possible aid in doing this job, but naturally, our country's defense needs come first.

As we have demonstrated in the past, Sylvania is ever mindful of the importance of its Service Dealers and servicemen to the nation and to the industry. We will continue to do everything possible to preserve the fine relationship existing between Sylvania, its distributors, and you, its loyal dealer customers.

Cordially yours,
SYLVANIA ELECTRIC PRODUCTS INC.

H. H. Rainier
Manager, Distributor Sales

INCANDESCENT LAMPS • RADIO TUBES • FLUORESCENT LAMPS AND FIXTURES • ELECTRONIC DEVICES

Bob Penfield, editor

copyright 1950, Sylvania Electric Products Inc.
Vol. 17, No. 9

FCC Adopts CBS-Type Color Television Standards

Over the objections of most leading television set manufacturers, the FCC has authorized the adoption of the Columbia Broadcasting System's color television system. The Commission acted to protect buyers against sets that might become outdated.

Under the new ruling CBS is authorized to begin commercial color television operations on November 20. The network has indicated, however, that they might not start regular programming until mid December.

The FCC order does not mean the more than 8,000,000 present set owners will be cut off from television reception. Cost factors will reduce general usage of color and black and white may never be completely replaced.

The new decision does mean that present set owners will have to buy adapters if they want to receive the CBS color signals in black and white and converters will be required if they wish to receive the pictures in color.

While recognizing the inconvenience to present set owners, the Commission said the CBS color system was the best of several and that it would be "derelict in our responsibility to the public if we postponed a decision any longer."

It pointed out that the longer the issue dragged on, the more people would buy television receivers that would have to be replaced or overhauled.

The manufacturers of television sets had urgently requested a delay in the final decision on color. Even so, there is a strong possibility that the introduction of commercial color may be delayed indefinitely. Some manufacturers have indicated that they may try to obtain a court injunction to prevent the Commission from carrying out its order.

Manufacturers have contended that it would take at least six months to produce sets capable of receiving the CBS color in black and white. Originally the Commission told the manufacturers it would adopt the CBS system only on a tentative basis if they began

making combination receivers at once.

It said, however, that they "have indicated that they are unable or unwilling to do so." By confronting them with no alternative except to make such sets, it added, the public will be protected against buying "more sets unable to receive color."

Since the original announcement by the FCC the following industry developments have taken place.

1. Many major manufacturers of receivers declared they would not make receiving equipment for CBS

color, and in any case, would continue making sets for black and white telecasts. They held that the CBS method is impractical and would ultimately prove obsolete.

2. The public seems confused over the ruling. Many prospective set purchasers are now undecided on whether to buy a television set.

3. Some small manufacturers have announced plans to start production of converters that would enable existing sets to receive CBS color.

4. An organization of retail dealers in New York has announced that it will consider legal proceedings against the FCC.

At this writing, the situation is, to say the least, confused. The next few weeks will be telling ones in the history of television.

Questions, Answers On Color TV

Approval of the CBS method of transmitting television pictures in color raises a host of complex questions, and to the extent that they can be given now, here are some of the answers:

What will be the effect of the color decision on the almost 8,000,000 black-and-white sets now in use?

Existing sets will not become obsolete overnight. Even CBS acknowledges that programs will be offered in black and white for perhaps several years. The consumer will have to pay more for additional equipment if he wants to have the most up-to-date device in his home.

When will color television come?

No one knows exactly. If some manufacturers take recourse to the courts to contest the CBS victory the delay might be of some length. CBS itself plans to start twenty hours of programs a week within two months.

Thus far most manufacturers have expressed strong disapproval of the system on both technical and economic grounds, but CBS was confident that the normal laws of competition would "break the jam."

How good is CBS color?

At their best, the color images are superior to the Technicolor seen in the movies. The hues are softer and more restful. A few looks at color television and black-and-white seems drab indeed.

How does CBS color work?

The basic television colors, which are red, blue and green, are injected by mechanical means. A disk containing segments of filters of the three colors rotates back of the lens of the camera that is picking up an event. In nontechnical language, it might be said that a picture is taken first in one color, then the next and finally the third.

On the receiving end, the process is reversed. Before the picture reaches the human eye, it passes through another revolving disk with the three primary colors. The eye makes what technically are separately colored images appear as one full-color picture.

If CBS is transmitting a color program, can a set now in the home continue to get CBS in black and white?

No. CBS color does not employ the same scanning standards as black-and-white. This means that a set owner must purchase an adapter to get the same service that he enjoys now.

Can a set now in use be converted to CBS color?

Yes. The cost of the necessary adapter and converter would run to at least \$100, according to CBS estimates. Some manufacturers, who note that CBS is not engaged in set production, believe the cost might run higher.

SYLVANIA NEWS

Merchandising
Section

OCT.-NOV. 1950—VOL. 17, NO. 9

SYLVANIA ELECTRIC PRODUCTS, INC. COPYRIGHT 1950



MAGIC?

In Business Hard Work Is the Only Magic . . . Here's ten suggestions for successful selling of service

No matter whether you're in the radio service business, television service business or both you want to be a success. Although there's no magic formula for success, here's a brief discussion about ten factors we think contribute to the success of any business. Use them as a guide post and you'll find you're headed towards better customer relations and bigger profits.

1. A Desirable Location

Before any business can begin to function, it needs a good location. Any area won't do. When choosing a spot to open a business make sure



it's a good one for stores in general and your kind in particular. The population of your trading area should be stable or growing and should include an adequate number of people whose age and buying habits make them potential customers.

Make sure your potential cus-

tomers have a buying power which will support your type of business and most of all, consider the amount and quality of competition that will be encountered.

Keep your eye on your trading area after your business has grown. Changes in the area can adversely affect the established business as well as a new business.



2. Skillful Buying

Care should be exercised in choosing a source of supply, but care must also be taken to see that your buying is not spread too thin. Your suppliers are in business for profit too and they can't give you good values and service unless your account is a profitable one to them.

The greatest service a dealer can give his customers is to provide the merchandise or service they want when they want it. If you don't have the merchandise when the customer wants it—if you don't give service when the customer wants it—you will not only lose a sale, but the customer's future patronage as well.

3. Effective Stock Control

Customer's purchases are the best indication of what is fast moving and what is slow moving. Keen businessmen watch customer preferences and buy sufficient quan-

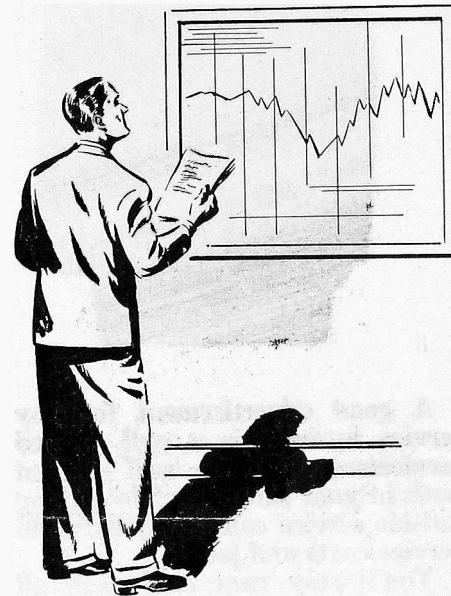

tities of fast movers. Slow movers are used to fill out the line. Inventories based on judgment alone result in sales from too small a percentage of stock. Sylvania distributors are equipped to aid dealers in setting up a simple stock control system which will aid in obtaining the biggest profits from your inventory.

4. Sound Merchandising

Sound merchandising attracts customers and builds sales. What then are the elements of sound merchandising which contribute to successful operation of a service business?

Developing a store personality. Every service shop has a personality all its own. This personality should be planned to appeal to the type of customer you want to attract. When you decide the type of clientele you want to attract, gear your store personality and merchandising accordingly.

(Continued on page M-34)

You'll Always Look Your Best With These



A good advertisement for any service business is a well dressed serviceman. To be well dressed both in your shop or while making outside service calls, wear Sylvania service coats and jackets.

You'll stay neat and clean all the time with these service garments. A white shirt and a tie

worn with these garments and you'll always be fresh as a daisy.

Sylvania service garments are well tailored garments made from rugged, hard-wearing fabrics. Big pockets at arms length in the service coat are good storage places for all types of odds and ends which belong only in pockets. Special

buttoning on the service coat allows kneeling on floors without the danger of spotting trousers.

The service jacket is made of the same rugged fabric as the shop coat. It is a single breasted, three button jacket which resembles a suit coat. It's neat appearance makes it extremely useful for service calls in homes and offices. It is preferred for shop use by many servicemen who know the value of good grooming when attending customers.

Sylvania service garments are available in an attractive grey-green color. All of your personnel will want Sylvania service garments for protection of their clothes and for their appearance.

The coats and jackets are available in five popular sizes, 36, 38, 40, 42, and 44. Price of the knee length service coat is \$4.00 and the Jacket is \$3.10.

Order Sylvania service garments for yourself and your employees. Your Sylvania Distributor has a stock, or they may be ordered from the Advertising Department, Sylvania Electric Products Inc., Emporium, Pa. When ordering from Emporium, please enclose your check, cash or money order. The garments will be shipped to you postpaid.

MAGIC? In Business Hard Work is the Only Magic

(Continued from page M-33)

Skillful advertising. Well planned and scheduled advertising is the most effective. Make your advertising fit your business. Make it appeal to your type of customer. You'll find plenty of help waiting for you from your distributors and the manufacturers they represent. Too much money, or too little spent on advertising is wasteful. Gear your expenditures to your anticipated sales.

Attractive window and interior displays. Window and store displays should again reflect your business personality. Window displays should indicate the character of your store, must appeal to the selected type of customer and must invite business.

Once in the store, the favorable

impression gained by the windows must be maintained. Displays which are attractive, colorful and clean help the customer in maintaining a favorable impression.

Well Trained Courteous Sales People. In the eyes of customers, sales people are the proprietors. Poor service or discourteous treatment by sales people can undo the good work of successful advertising or attractive window displays. Sales clerks' action can wipe out, in a few seconds, the good will of regular customers which the store has built up over a period of years.

Sound Credit Policies. Extension of credit is an excellent means for increasing sales volume. Granting credit, however, involves additional costs in financing and bookkeeping,

(Continued on page M-36)

Picture Tube Sales Double In August

August 1950 sales of television picture tubes to set manufacturers more than doubled July figures, according to RTMA member-company reports. August sales to the set producers totaled 767,051 picture tube units, valued at \$20,335,873. The July sales to set manufacturers was 341,940 units valued at \$9,133,745.

Television picture tubes 16 inches and larger accounted for 87 percent of the total sales to manufacturers. That percentage figure keeps pace with the public demand for television screens of ever-increasing size.

Over half (51%) of the television picture tubes sold in August to the set manufacturers were rectangular screens. This, the RTMA report said, was an increase of 47 percent over the similar July sales figure.

SYLVANIA NEWS

SYLVANIA NEWS

OCT.-NOV. 1950

Copyright 1950
Sylvania Electric Products Inc.

VOL. 17, NO. 9

TECHNICAL
SECTION

The information in Sylvania News is furnished without assuming any obligations

Technical Editor A. V. BALDWIN

DEFLECTION TUBES and CIRCUITS for Wide - Angle Picture Tubes

by James S. Allen

Commercial Engineering Department

The introduction of wide deflection angle picture tubes which produce large pictures without requiring extreme depth in the cabinet, has brought about the development of new scanning tubes, transformers and yokes to produce the required scan.

It may be shown that the power required to deflect the electron beam in a picture tube is proportional to both the deflection angle and the second anode potential. To better understand this, let us assume an imaginary picture tube in which we may vary the deflection angle at will. For a very low deflection angle, only a small amount of power will be required to bend the beam from side to side. As the deflection angle is increased, more effort must be expended to deflect the beam. Suppose now that we hold the deflection angle constant and vary the anode potential. Increasing the anode potential has the effect of increasing the "stiffness" of the beam. The higher the anode voltage, the more the beam resists being

bent. In the actual case of changing from a low angle, low potential tube, 52° and 10 Kv, to a wide angle, high potential tube, 70° and 13 Kv, the two effects are combined. As a result, 2.4 times the previous deflection power is necessary which generally requires the use of a higher powered deflection tube.

Improved Components Developed

To meet the more difficult requirements of wide-angle deflection, new tubes and component parts were developed. The most pressing need was for higher efficiency. In television receivers employing magnetic deflection with the anode potential developed from the flyback yoke voltage, the horizontal deflection circuit consumes more DC power than any other part of the receiver, approximately 50 watts in some cases. It was desirable to design components and tubes so that wide-angle picture tubes could be scanned with less rather than more power consumption. The greatest stress has been placed on horizontal scan-

ning circuits and much has been done in the past few months. Tubes and components have been developed that allow adequate scan of wide-angle picture tubes with the same or lower power consumption and in many cases at lower supply voltages than has been the case in receivers using low angle picture tubes. Recent tube developments for horizontal scanning are Types 6BQ6GT, 6AU5GT, 6AV5GT and 6CD6G. These tubes have in common the ability to deliver a large plate current swing at a moderate supply voltage, a prime necessity for efficient operation and good scanning ability.

Transformers and yokes have been improved greatly by the use of more efficient magnetic material for the cores and by careful control of transformer characteristics, particularly the coupling between the primary and secondary. An effect known as Barkhausen oscillations may result if the damper does not satisfactorily rectify and damp

(Continued on next page)

Sylvania Picture Tube Chart Revised

A revised edition of the popular Sylvania Television Picture Tube chart is now available free from your Sylvania Distributor.

The new chart contains data on 147 basic types of cathode ray and picture tubes. The possible variations of screen material and face plate treatment were not counted in obtaining this figure.

The tabular material listed for the magnetic type picture tubes has been completely revised. Bulb con-

struction, type of high voltage terminal, face plate color, deflection angle and filter capacitance are now listed. Some minor changes in arrangement make it easier to find the type of ion trap required and to indicate the useful dimensions for rectangular tubes.

Your free copy is available from your local Sylvania Distributor or from Sylvania Electric Products Inc., Advertising Department, Emporium, Pa.

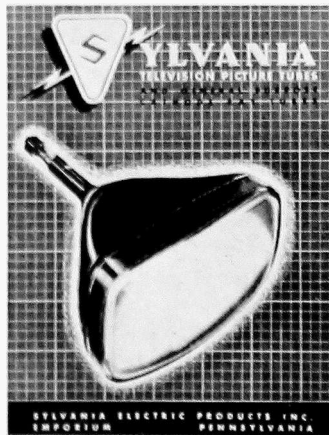

out the self oscillation of the transformer-yoke combination following the beam retrace interval. By keeping the primary-secondary coupling as tight as possible, the damping upon the plate of the deflection tube is increased and the production of Barkhausen oscillations therefore is minimized.

Higher anode voltages than 9 or 10 Kv are obtained by one of two ways. In some cases, a voltage doubler circuit is used. In others, the step-up ratio of the autotransformer section of the output transformer has been increased so that high anode potentials may be obtained with one rectifier.

A typical circuit for Type 6CD6G is shown in Figure 1. It will be noted that a voltage doubler circuit is employed to obtain the high potential for the picture tube anode. Figure 2 shows a horizontal scanning circuit suitable for Types 6BQ6GT, 6AU5GT and 6AV5GT. In this case, the anode voltage for the picture tube is obtained with a single rectifier by using a very high step-up ratio in the transformer so that a pulse of sufficient magnitude is applied to the plate of the rectifier to supply 13 to 14 kilovolts of DC to the picture tube.

Boost Circuits for Increased Efficiency

Nearly all present day television receivers utilizing magnetic deflection use some form of power feedback in the horizontal scanning system to increase the supply voltage to the horizontal output

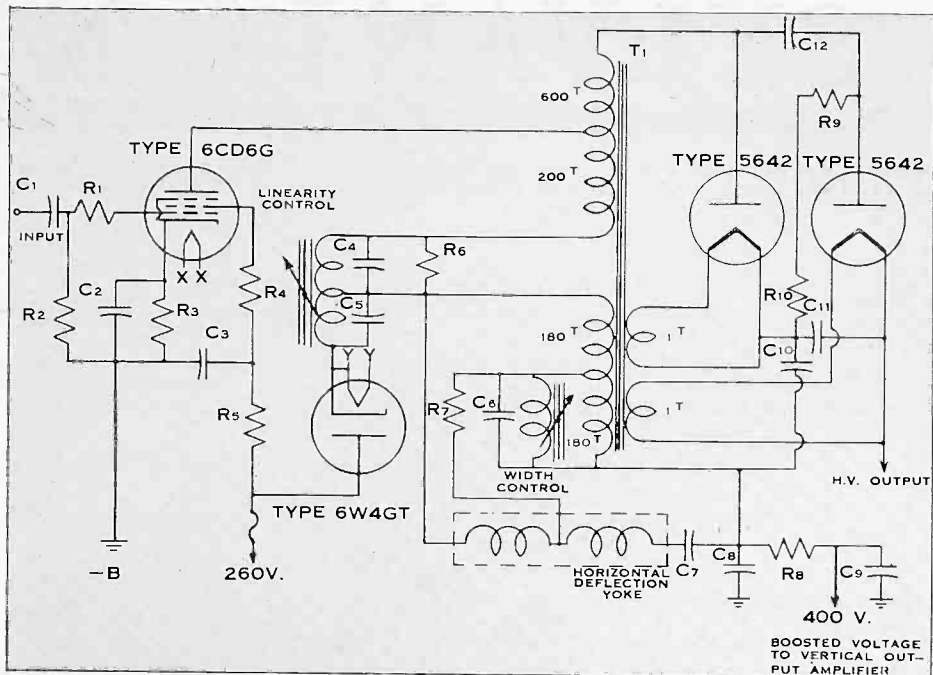

FIGURE 1—Typical horizontal deflection circuit for the Sylvania Type 6CD6G beam power amplifier for TV receivers. Circuit constants are given in the Technical Manual insert sheet supplied with this issue of Sylvania News.

stage and to increase efficiency above that available from the power supply (See Figure 2). Power feedback is obtained by recovering the energy that is released when the magnetic field in the deflection yoke collapses during the retrace interval. During this interval, a large negative pulse appears across the yoke. This is a half cycle of oscillation at the resonant frequency of the transformer-yoke combination, about 70 Kc. As the positive half cycle begins, however, the damper rectifier conducts and rectifies the positive

swing, effectively damping out the oscillation. The DC voltage that is produced by the rectification of the positive swing appears across C_3 and C_6 and is added to the power supply voltage, with the total being supplied to the output tube. Since the energy recovered by the damper diode is stored in the condensers for use on the next swing the desired deflection is obtained with less power from the DC supply.

The boosted voltage appearing at the junction of C_3 and L_2 may also be used to supply the vertical deflection system through a suitable filter to decouple and prevent interaction of the two systems. Such use of the boosted voltage is sometimes necessary because the receiver supply voltage alone is often insufficient to supply ample vertical scan, since the angle of scan has been increased in both directions.

Vertical Scanning Systems

Vertical scanning systems have not undergone as much change. In some cases the same tube (Type 6V6GT triode connected) is used now for wide angle applications. However, many new sets use the new tubes developed and specially rated for the peak voltages occurring in scanning circuits. The new tubes include the twin triodes 6BL7GT and 12BH7 as well as a single triode Type 6S4. Types 6BL7GT and

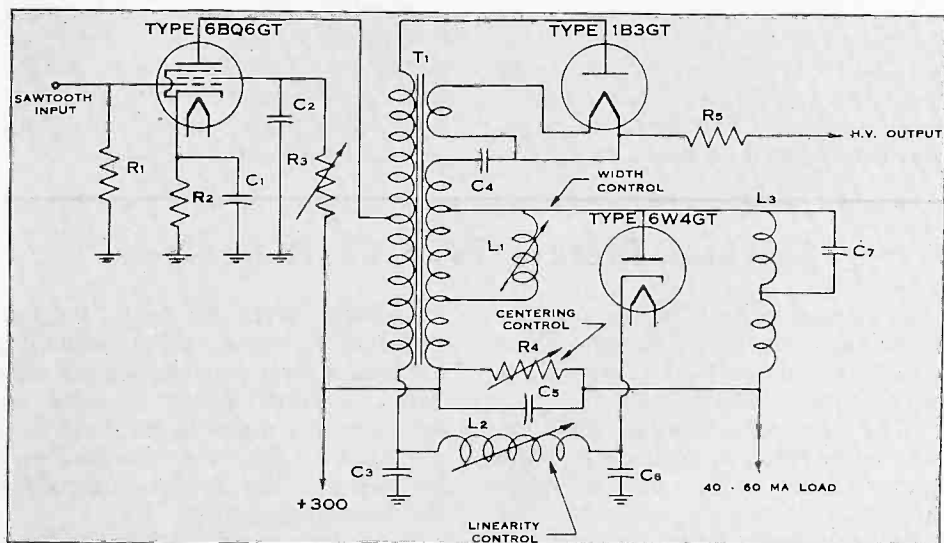

FIGURE 2—Typical horizontal scanning circuit for Sylvania Types 6BQ6GT, 6AU5GT or 6AV5GT. Circuit constants are given on the Technical Manual insert sheet published as a supplement to the August issue of Sylvania News.

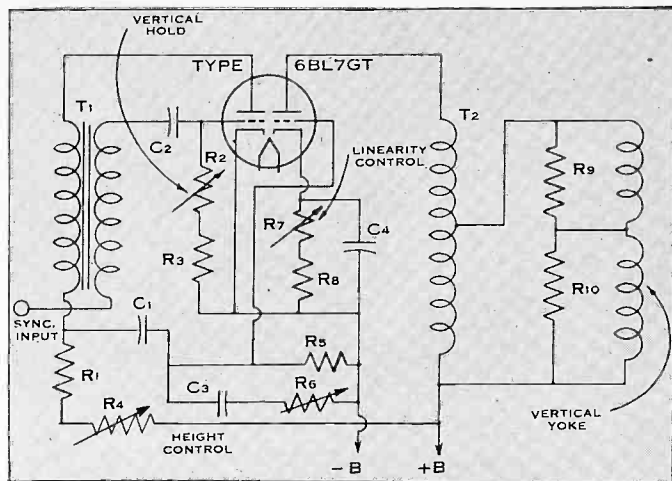

FIGURE —Typical one tube vertical scanning circuit for the Sylvania Types 12BH7 or 6BL7GT.

12BH7 are designed to be used with one section operating as a combined blocking oscillator-discharge tube, and the other section as the output amplifier, as in Figure 3. Type 6S4 is used as the output amplifier only, with a Type 6SN7GT or similar type as the blocking oscillator.

It might be pointed out that if any older receivers are giving trouble with insufficient vertical scan about 10% more height can be obtained by replacing the Type 6SN7GT with a Type 6BL7GT. No circuit changes are necessary and the tubes have the same basing. However, additional heater current is required.

Wide-Angle vs. Low-Angle Tubes

Deflection yokes designed for use with low-angle picture tubes will not work with wide-angle tubes. One reason for this is that the deflection yokes for low-angle picture tubes are longer than those for wide-angle tubes. Consequently, the point at which the beam bends is farther down the neck of the tube toward the base than is the case

with short yokes designed for wide-angle tubes. If a low-angle yoke is used on a wide-angle tube, the beam will strike the neck causing a shadow to appear on the face of the picture tube. Figure 4 (a) shows the effect of using a long yoke on a wide-angle picture tube. Notice that the deflection center is so far down the neck of the tube that the beam is obstructed by the bulb before it is possible for it to reach the extreme edges of the tube face. Figure 4 (b) shows the effect of using a properly designed short yoke. Here we see that the deflection center has moved toward the front of the tube and the beam is now able to clear the bulb and scan out to the edges.

Replacement of Low-Angle Tubes with Wide-Angle Tubes

In view of the increasing interest in larger pictures, many servicemen will be faced with the task of trying to replace low-angle picture tubes in older receivers with wide-angle picture tubes. These conversions

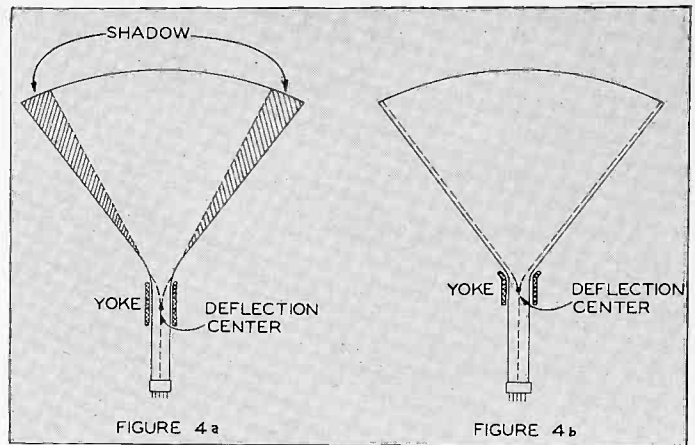
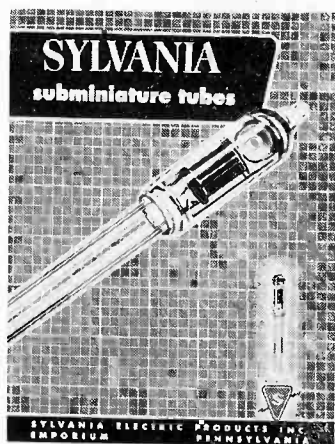

FIGURE 4a—Diagram showing the shadow produced by use of a long low-angle yoke on a wide angle picture tube.

FIGURE 4b—Short deflection yoke moves the deflection center forward to prevent neck shadow.

may be relatively easy or extremely difficult depending on the receiver. We can, however, outline in general what must be done. First, the deflection yoke must be changed for the reasons pointed out earlier in this article. Whether the output transformer must be changed depends mostly on how much reserve deflection power was available in the original receiver, and whether a higher power output tube can be substituted for the original. For example, it might be possible to retain the original transformer and replace a Type 6BG6G output tube with Type 6CD6G and obtain satisfactory scan provided the power transformer and rectifier will supply the extra power required. Usually, however, it will be necessary to replace the output transformer with one designed specifically for wide-angle deflection service. When the new transformer and yoke are installed, the original output tube is generally replaced with a later type, such as 6CD6G, 6BQ6GT, 6AU5GT or 6AV5GT.



Sylvania Subminiature Tube Chart

Sylvania has just prepared a new Subminiature Tube Characteristics Chart in which servicemen and experimenters alike will be interested. This new publication is another member of the well-known group of characteristics charts which give the most essential tube data in convenient tabulated form. Because the subminiature tubes are so new and, at present, less commonly used, the data are given in greater detail, enabling experimenters to work out their own mounting arrangements

and circuit applications.

The thirty types currently available are included, but, as facilities permit, the line will be expanded and data presented in a future issue of this chart.

Be sure to get your free copy of Sylvania's new Subminiature Tube Characteristics Chart from your local Sylvania Distributor or by writing to Sylvania Electric Products Inc., Advertising Department, Emporium, Pa.



TEST EQUIPMENT CORNER

Preamplifier For Sylvania Type 131, 132 Oscilloscopes

by R. C. Lepley

Commercial Engineering Department



Experimenters and service technicians will probably be interested in the scope preamplifier shown here. It will prove handy in any shop for those occasional cases when the signal being traced is too small to show up well on your screen and the gain of approximately 30 obtained with this circuit would be ideally suited for the application.

No power supply is shown, but it is now recommended that this be obtained from the scope as the positive voltage supply was not designed to handle the additional current drain. Any power supply with an output of at least 10 ma at 150 to 250 volts will be satisfactory, although a regulated supply will give a much steadier scope pattern. If the available supply is not regulated but will supply 30 ma. or more voltage regulator tubes and a suitable current limiting resistor connected in series across the output from the power supply will do equally well.

The circuit is a conventional resistance coupled amplifier with an unbypassed cathode resistor to provide negative feedback and stability. The preferred tube is the non-microphonic Sylvania Type 1273, but Types 7AJ7 and 7C7 may be used if desired. The value of R2 should be changed to 100K for Type 7C7 because of its slightly lower

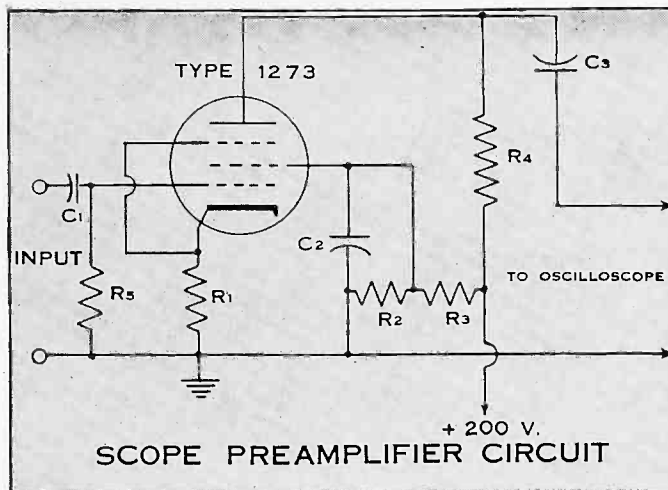

Table of Values

C1	0.1 μ f.
C2	10.0 μ f.
C3	0.1 μ f.
R1	270 Ohms
R2	150 K
R3	56 K
R4	27 K
R5	10 Megohms

screen current.

No volume control is necessary since the gain control on the scope will be adequate. In order to avoid overloading and distortion in the amplifier itself, however, do not use it for signals which give a satisfactory deflection without additional amplification.

The sample made here using a Type 1273 tube was measured for gain and response and found to be as follows:

Gain 30.0

Frequency Response:

$\pm 10\%$ from 10 cycles to 70Kc (1000 cycles reference)
down not more than 15% at

90 Kc

down not more than 25% at 145 Kc

Notice that the response characteristic obtained by use of the low value of plate load resistor gives a bandwidth suitable for use with the Type 131 and 132 scopes providing additional gain for owners of such instruments. However the high-gain, wide-band characteristic of the new Sylvania TV Oscilloscope Type 400 may be required for some types of work. Sylvania's latest general purpose Oscilloscope Type 132Z has increased sensitivity (100 millivolts rms sine wave gives 1 inch peak-to-peak deflection).

Suggestions For Using Sylvania Type 219 - 220 Tube Checkers

Testing "In-Line" Subminiatures

In testing subminiature tubes with "in-line" leads look for the small raised dot at the left of the socket. This dot corresponds to a similar marking on the tube which should always be inserted beginning at the left. Thus a subminiature tube with 5 leads will occupy the first five holes at the left end of the socket. The two remaining holes at the right will be vacant.

Erroneous Gas Test

There have been some reports from the field that Sylvania Tube Testers Type 219 or 220 have falsely classified some good tubes as being gassy. In all cases this has been traced to the operator trying to make the gas test on a diode or the diode section

of a tube. The instruction book specifically states that the gas test does not apply to diodes. To make the point clearer, future roller charts will have a star printed after the "G" setting of all diodes. A note on the chart will indicate that the gas test should not be made.

Testing Ballast Tubes

Ballast tubes are frequently encountered which show continuity when cold but open when heated. Tests can now be made for hot continuity with Sylvania Type 219 or 220 tube testers when the basing is known. The procedure is as follows:

- (1) Set the "A" switch to the voltage nearest to the rated drop across the section of the ballast to be tested.
- (2) Set the "B" switch to the pin

number corresponding to one end of the section of the tube being tested.

(3) Put all C/F switches corresponding to all base pins actually connected in the entire ballast tube to "C" position.

(4) Turn the "E" switch to the other end of the section selected for test by "B".

(5) Insert the tube in the proper socket.

(6) Pull down the "Fil." switch. The meter will indicate up in the green for a good tube. It will not move if the section of the tube being tested is open. (The voltage set by the "A" switch is removed when the "Fil." switch is pulled down.)

(7) Reset "A", "B" OR "E" switches as required for other sections of the tube to be tested. Test with "Fil." switch as before.



Pleasant smiles from Bridgeport, Conn. dealers are for Clarence Simpson who conducted a television service chalk talk recently. Meeting was sponsored by Hatry & Young, Sylvania Distributor, and is part of Sylvania's continuing program of service meetings being held throughout the country.

New England Dealers Get Tips On TV Service

Latest group of service dealers to hear Clarence Simpson give helpful tips on television service were those in seven New England cities.

Making the rounds for Sylvania and distributors, Clarence recently visited seven cities in New York, Massachusetts and Connecticut where he spoke to service dealers about diagnosis of television set troubles.

Sylvania Television Service Meetings is a continuing program sponsored by Sylvania Distributors in all parts of the country. The program is designed to bring service dealers first hand information about the service business. The meetings are non-commercial, educational programs.

The general program of the meetings is to discuss the methods of detection and correction of television set faults, in all types of receivers.

West Coast Next On Schedule

The next series of meetings are scheduled for the month of November. Place of the meetings will be on the West Coast. A definite schedule is not available at the present time, but your Sylvania Distributor will supply you with full information about the program in your locality.

Serving servicemen and dealers in the Hollywood Calif. area is Sylvania Distributor, Western Electronic Supply Co. The three trucks shown below deliver parts and tubes to the door of dealers. In the picture are left to right, Jack Waring of Western Electronic Supply and Sylvania's Pat Patterson and Harold Rainier.



Unidentified beauty above pulls names out of giant Sylvania Tube carton for door prizes awarded to audience at Bridgeport, Conn. service meeting. Looking on, l to r is Clarence Simpson, Al Kaufmann of Hatry and Young, "Pat" Patterson and Sam McDonald of Sylvania.

Prompt Delivery Of Dealer Supplies Aids West Coast Service Business



MAGIC? In Business Hard Work Is the Only Magic

(Continued from page M-34)

mailing, collection and losses from unpaid accounts. If you must give credit in the service business, care should be taken to see that losses are kept at a minimum and that provision for loss should be allowed in pricing of your service.

5. Proper Pricing

When prices are too high business is lost because people won't buy. When they are too low the dealer's net income will suffer and he will be placed in a dangerous financial position.

In pricing your service make sure you will cover expenses for parts, tubes, etc., overhead and allow for a profit. Such pricing is not always possible or desirable but it should be carried out in the majority of cases.

6. Adequate Financing

Success in every business depends greatly on the amount of capital available for the purchase of an adequate stock of merchandise, for operating expenses and for cash reserves for emergencies. If you extend credit, additional capital or source of credit must be available to finance this type of sale.

Prompt payment of bills enables the service dealer to lower his cost of merchandising by taking advantage of cash discounts offered for prompt payment. This always results in a better credit rating and reputation in the trade. It means more favorable consideration by suppliers and bankers.

The serviceman is a merchant not a speculator in merchandise. He should buy carefully in small enough amounts to stay within the limits of his customer's demands and his available capital. A retailer must have adequate working capital at all times. He must realize he will be given credit by suppliers and bankers only if he keeps his business in a liquid position.

7. Adequate, Helpful Records

Any business has yet to succeed without the aid of adequate financial records. Through them the service dealer has at all times the necessary information to assure effective control of purchases, sales, expenses and other operations. Continued

study of business records reveals unfavorable conditions before they have had a chance to do serious harm to your business.

Records are important too in preparing reports required by federal, state and municipal governments. They are necessary as a source of information in preparing and supporting tax returns such as income tax and social security.

8. Good Housekeeping

Some service dealers fail to realize that they are housekeepers of stores which are visited by guest-customers at frequent intervals. The dealer who recognizes this fact and works towards maintaining an attractive store increases his opportunity for success.

Factors which aid good housekeeping include such things as adequate lighting, fresh, clean paint, good ventilation and orderliness about your store. Each of these points requires special attention and each contributes to the good housekeeping of any service shop.

9. Service to Customers

Good service to customers is one of the major factors which helps any business become successful. By good service we mean prompt service. Taking care of customers quickly and efficiently. Aiding them in every way you can to make their job of buying easier.

Convenient store hours are also important in attracting customers. Store hours should be arranged for the convenience of customers, not to suit the store personnel or the retailer. Remember customers can shop around and choose shops whose hours are most convenient for them.

One of today's "musts" for customers services is adequate parking. More and more customers use automobiles when shopping. If your business is located in a new neighborhood or a suburban area,

adequate parking spaces can usually be provided with little difficulty. Small downtown service dealers, however, cannot do this without involving considerable expenses. This is a problem which will become



increasingly important to the customer and the dealer as well. It will demand a great amount of consideration by service dealers as time goes on.

10. A Friendly Pleasing Personality

Perhaps the most important single element in the success of any small business is the personality of the owner and those people who work for him. To be successful, the service dealer must like people and like talking with them, mixing with them and servicing them. He must recognize the fact that his customers are really his employers and that they will employ him for his services only as long as he serves them well. As an essential part of his personality, the service dealer must have a good knowledge of customer wants, personal acquaintances with many of his customers and an interest in his community.

These ten factors in successful service shop operation are only as good as the man behind them. In order to be successful in business and to operate any business at a profit the service dealer should make sure he is employing every possibility for greater customer satisfaction. Satisfied customers effectively drawn into your place of business are the surest way of continued success.



Ralph Shields, Sylvania test equipment engineer tells PRSMA show audience need for good test equipment and techniques to insure bigger profits and customer satisfaction in servicing TV receivers.

PRSMA Show Brings Late Industry Developments to Large Serviceman Audience

Need of good test equipment
In TV service stressed by
Sylvania Engineer Ralph Shields

One of the most successful meetings ever held by service dealers for their own benefit was the PRSMA convention and Show held last month in Philadelphia. This convention combined both a show and a forum in which problems of the servicemen were aired.

During the three day session all phases of radio and television service were covered by a host of speakers. New products were shown in the exhibit hall by the thirty odd manufacturers who had booths.

Among the speakers at the meeting was Ralph Shields, Sylvania engineer who spoke on test equipment selection and servicing. During

his talk, Shields said the TV servicemen can get the best results from test equipment by learning how to use it properly.

Good testing equipment, according to Shields, satisfies customers by giving the best results in the least amount of time and more profitably as well. Proper test instruments combined with good techniques reduce the time required for TV servicing, increases the serviceman's profit and assures the customer satisfaction. Shields warned servicemen, however, that good techniques are usually acquired over a period of time in actual practice at a service bench.

Touching on some of the problems facing TV servicemen, Shields cited

the fact that the uninitiated may get the impression that TV test equipment represents a "magical group of devices which upon being placed close to a defective TV receiver, will reach out and fix it." He said that this, of course, was not so but the best TV set performance does require the use of reliable test equipments of good quality to demonstrate just what is happening in many complicated TV circuits.

Other speakers at the three day meeting spoke on such varied subjects as "Shop Overhead Analysis," "Picture Tube Conversions," "Color Television," and other subjects dealing with the servicing of various TV circuits.

Justin McCarthy, left, Sylvania representative, demonstrates the Sylvania Tube Tester to Stanley Meyers, center, PRSMA Treasurer. Looking on is Sylvanian Bill Maguire. Myers also edits PRSMA NEWS, monthly publication of the Philadelphia association.

Richard Devaney, member of the PRSMA advisory board discusses the convention program with Ralph Shields. Shields was one of the speakers during the three day PRSMA show. Other speakers told of new industry developments and trends in TV service.



All Smiles For West Coast Show



Representing Sylvania at the Pacific Electronic Conference at Long Beach, Calif. were, l to r., Harold Rainier, distributor sales manager, Lou Nieman, model Beverly Jones, Barbara Stephenson, John Wood, Harold Fontaine, Ray Guion, Pat Patterson, Carl Brown, Sylvania Distributor from San Francisco, Ed Gilbert. Background on the right is the Sylvania Booth which drew a large attendance at the show.

Facts & Figures...

Radio-TV Set Production At Peak Level for 1950

Television receiver production reached a new peak of 702,287 sets in August. This brings the industry total for the first eight months of the year to an estimated 4,146,602 sets, according to the RTMA industry estimates. This output through August was 1.1 million units higher than that for the entire year of 1949.

Running counter to seasonal trends, both radio and TV set production during the summer, except for periods of vacation plant shutdowns, has continued to climb.

August radio set production was estimated at 1,203,477 units and 8,750,965 during the eight months of 1950.

Estimates of set sales by manufacturers also indicated that new records have been achieved. During the first eight months of 1950, manufacturers are estimated to have sold more than \$700 million worth of TV sets and \$210 million worth of radios, figured at manufacturers price. These combined figures well exceed total set sales for the whole of 1949.

3,107,000 TV Sets Shipped To Dealers

3,107,000 television sets were shipped to dealers throughout the country during the first seven months of 1950, according to RTMA estimates for the industry based on reports by member-companies.

Shipments in the month of July totalled 495,000. That was an increase of 206,000 television sets shipped to dealers in June 1950.

In This Issue

NEWS

FCC ADOPTS CBS COLOR TELEVISION

MERCHANDISING
MAGIC?

TECHNICAL
DEFLECTION TUBES AND
CIRCUITS

SYLVANIA NEWS

SYLVANIA ELECTRIC PRODUCTS INC.
P. O. BOX 431
EMPORIUM, PENNA.

Sec. 3486, P. L. & R.
U. S. POSTAGE

PAID

Permit No. 1
Emporium, Pa.

For

J. A. Renville
163 Main St.
Luzerne, Pa.

A

POSTMASTER: IF UNDELIVERABLE FOR ANY REASON, NOTIFY SENDER,
STATING REASON, ON FORM 3547, POSTAGE FOR WHICH IS GUARANTEED.

Vol. 17, No. 9

OCTOBER-NOVEMBER, 1950

PUBLISHED BY
SYLVANIA ELECTRIC PRODUCTS INC.

MANUFACTURERS OF SYLVANIA RADIO TUBES, CATHODE RAY TUBES, ELECTRONIC
DEVICES, FLUORESCENT LAMPS, FIXTURES, WIRING DEVICES, ELECTRIC
LIGHT BULBS, PHOTOLAMPS, RADIO AND TELEVISION RECEIVERS

SYLVANIA NEWS

BOB PENFIELD, Editor

December 1950

VOL. 17, NO. 10

Copyright 1950, Sylvania Electric Products Inc.



It's Not As Bad As One Might Think!

by Harold Rainier
Manager of Distributor Sales



HAROLD RAINIER

One of the more critical problems facing the servicing industry today is the unprecedented demand for receiving tubes. This demand, which might be termed a "shortage," is really a result of the continual growth of the radio industry and

has been accentuated more by the phenomenal growth of the television industry.

During the past year, the tube makers, including Sylvania, have expanded their production facilities by varying degrees, but there still remains an unprecedented demand which will result in a scarcity of many tube types for some time. Information published by the RTMA which includes reports of all tube makers, show the sale of tubes for replacement use has increased 85% in the first nine months of 1950, over 1949.

In order to see how this demand has developed, let's take a look at how the service and manufacturing industry has expanded. In servicing radios alone, the normal demand for tubes is about .6 tubes per year for every set in operation. This in itself has been developing over the past few years, for, in spite of the backseat taken by radio in many of our minds, the sale of new radios is holding and the number of radios in use, including those in automobiles, has increased from 62,700,000 at the end of 1945 to an estimated 88,900,000 at the end of 1950. Tube demands for replacements in these sets has also increased from 40,700,000 in 1946 to over 50,000,000 in 1950.

Television alone has caused a great increase in the number of tubes required for replacement in the past few years. In the latest estimates prepared by the Sales Research Department of Sylvania, it is calculated that during 1950 the servicing industry will probably

use over 20,000,000 tubes for repairing television sets.

Since a greater number of tubes are required in the manufacture of TV sets, the tube industry has had to expand its manufacturing facilities greatly during the past few years. The expansion will be continued during the coming year. It will also be necessary because of the increased demand for tubes by the armed forces.

Though it might be suggested that the manufacturing industry has been receiving increased quantities of tubes at the expense of the servicing industry, this is not so. Since the beginning of 1950 the servicing industry has been getting an increased number of the tubes. In January of this year the servicing industry used 3,898,000 tubes. During August replacement tube sales to the industry were 7,017,000, nearly twice those of January.

If nothing else, these figures should indicate to servicemen that their business is a growing one. By 1955, barring extraordinary demands by the government, servicemen can be expected to use over 100,000,000 tubes for repairing radio and television sets, in that year alone. This compares with about 29,000,000 replacement tubes needed by servicemen in the last prewar year of 1940.

The expansion of the industry will take time. New machines, new factories and personnel take months to develop and train. The industry and Sylvania are rapidly moving forward to meet the new demands to the industry.

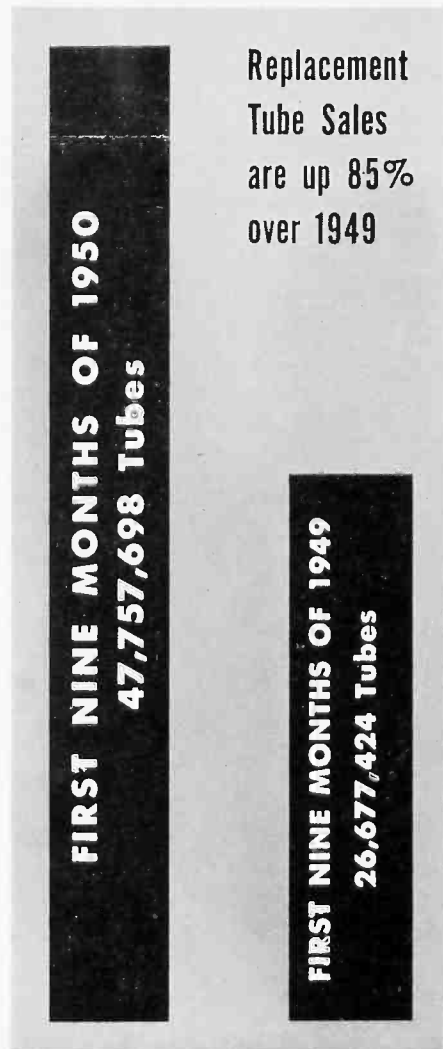

SYLVANIA NEWS

Merchandising
Section

DECEMBER 1950—VOL. 17, NO. 10

COPYRIGHT 1950
SYLVANIA ELECTRIC PRODUCTS, INC.

Profits Come With Pen and Ink

Inadequate Records Is Biggest
Cause of Business Failures
Here's a Record System
Especially For Service Business

Money is an elusive commodity. If you are a business man, money is the prime requisite for success. How you handle your money, more specifically, is the making or breaking of many a business.

The first rule to follow in financial management is adequate and accurate record keeping. Hit or miss methods are not sufficient. If for no other reason, accurate, up-to-date records of financial transactions must be kept in order to satisfy the laws of the land. Today, more than ever, the service business must keep better financial records.

Television, piled upon the complicated business of servicing radios, demands a close surveillance of finances. In short, record keeping is a sink-or-swim function of every business man.

Designed especially to meet the record keeping requirements for the radio and television service business is the Sylvania Business Record. This record book along with Sylvania Job Record Cards will help keep any service business out of financial hot water.

Record keeping, however, is not a oneway street. It depends on the cooperation of the business management to make it work successfully. With the Sylvania Business Record Book, this cooperation is easy.

In keeping correct, useful records, the first step is to maintain a complete account of each business transaction. Sylvania Job Record Cards are an easy way to do this. These cards are records of parts used, cost and labor involved in every service job.

The records of each business transaction are, in themselves inadequate for a complete record. This is where the business record

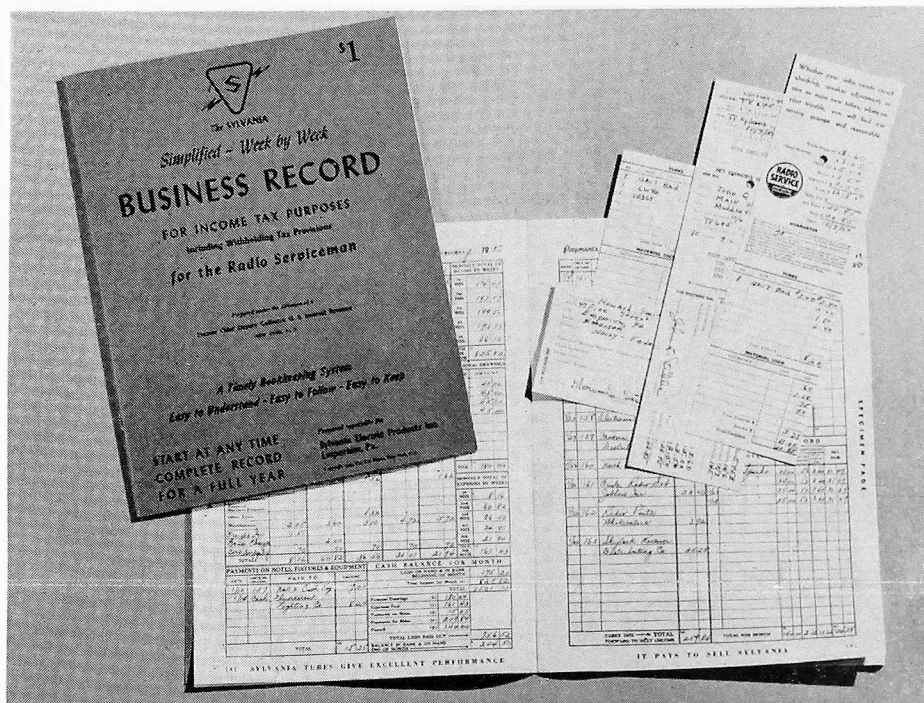

Everything needed for complete and accurate records of service dealer financial transactions is shown above. On the left is the Sylvania Business Record, complete financial record of the business. Right is sample Sylvania Job Record cards. These list complete details about every service job. Both are available at modest cost through Sylvania's advertising department.

book fits in. The Sylvania Business Record Book provides a complete record for a year. It helps keep account of the merchandise purchased, the salaries paid, money received and the cost of doing business. In short the Business Record Book is a complete accounting system in simple form.

The book is arranged in two parts. Part One includes a record of daily income for a month, weekly expenses for the month, personal drawings, payments on notes, fixtures and equipment and a cash balance sheet for the month. Part Two provides a record of payments for merchandise and a record of money paid to employees for their services.

Let's look at each section of the record separately to see how it fits into the service business. The daily income record is a simple account of money received for merchandise or service. The receipts

for each day can be entered in a few minutes from job record cards and the cash box total.

The week by week "Record of Expenses" shows how much is paid out for overhead expenses such as supplies, rent, repairs, electricity, gas, telephone, insurance and other items which are necessary for operation but which contribute nothing to the income of the business. Generally these items can be deducted from income taxes as legitimate cost-of-doing business items.

Personal drawing for salary to the owner or the partners of the business are recorded in the special portion provided in the Sylvania Business Record Book. Here is an accurate account of the money paid to owners of the business. This record is important because it must be clarified on income tax returns.

The column, "Payments on Notes,"
(Continued on page M-40)

Public Told Sign of Good Service by TV Expert

Selling radio and television service to an audience of more than 6,500,000 people is the job of Bob Shepard, announcer on Sylvania's "Beat The Clock" television show. Bob tells listeners that the place to get dependable service on their radio or television set is at the Sylvania sign. Tie-in your business with this popular television show by displaying the RADIO TELEVISION SERVICE decal. Get a supply today from your Sylvania Distributor or from the Advertising Department, Sylvania Electric Products Inc., Emporium, Pa.



Listen To "Beat The Clock" Here's The Time And Station

Here's an up-to-the-minute list of television broadcast stations carrying Sylvania's popular television show "Beat The Clock." The twenty-eight cities in which "Beat The Clock" is broadcast cover 55% of the radio service market and 85% of the television

service market in the country. Commercials on the program plug the service man who displays the Sylvania RADIO TELEVISION SERVICE DECAL as the sign of dependable service for all radio and television sets. Make sure you use this valuable aid to sell service.

ON THE COVER



One of the hostesses for Sylvania on the "Beat the Clock" television show over the CBS network is Roxanne, the girl on our cover this month. If beauty can sell service, Roxanne will have customers pounding on your door. In the vital statistics department, Roxanne is 21 years old; comes from Minneapolis, Minn.; has lived in New York for a year and a half. Roxanne appeared recently on the cover of Collier's and, along with Jane Russell, is the only girl to have appeared twice on the cover of SEE. Roxanne likes dancing and classical music and her ambition is to become a television actress.

CITY	STATION	LOCAL TIME	DAY
New York	WCBS-TV	10:30 PM	Friday
Atlanta	WAGA-TV	10:30 PM	Friday
Baltimore	WMAR-TV	10:30 PM	Friday
Birmingham	WAFM-TV	9:30 PM	Friday
Boston	WNAC-TV	8:30 PM	Tuesday
Charlotte	WBTV	10:30 PM	Friday
Chicago	WBKB	11:00 PM	Wednesday
Cincinnati	WKRC-TV	10:30 PM	Friday
Cleveland	WXEL (ABC)	7:00 PM	Saturday
Columbus, O.	WBNS-TV	10:30 PM	Friday
Dayton	WHIO-TV	11:30 PM	Friday
Detroit	WJBL-TV	7:00 PM	Friday
Greensboro	WFMY-TV	10:30 PM	Friday
Jacksonville	WMBR-TV	10:30 PM	Friday
Louisville	WHAS-TV	10:15 PM	Friday
Lancaster	WGAL-TV	2:30 PM	Sunday
Philadelphia	WCAU-TV	11:00 PM	Saturday
Phoenix	KPHO-TV	10:30 PM	Sunday
Syracuse	WHEN	10:30 PM	Friday
Washington, D. C.	WTOP-TV	10:30 PM	Friday
Los Angeles	KTTV	10:30 PM	Friday
San Francisco	KPIX	10:30 PM	Friday
Seattle	KING-TV	11:00 PM	Friday
St. Louis	KSD-TV	10:30 PM	Friday*
Johnstown	WJAC-TV	10:30 PM	Sunday
Salt Lake City	KSI-TV	7:30 PM	Wednesday
Indianapolis	WFBM-TV	10:30 PM	Saturday
Minneapolis	WTCN-TV	11:30 PM	Saturday

*Alternate Friday nights beginning December 1.

SYLVANIA NEWS

DECEMBER 1950

Copyright 1950
Sylvania Electric Products Inc.

VOL. 17, NO. 10

TECHNICAL
SECTION

The information in Sylvania News is furnished without assuming any obligations

Technical Editor A. V. BALDWIN

NEW DEVELOPMENTS IN TELEVISION TUNERS

By

Paul J. Erdle and
Wendell K. Boots

Commercial Engineering Department

A discussion of new developments in television tuners must necessarily be limited to general trends, which will include some older systems with significant changes for present and future utilization. New receiver developments exert considerable influence upon tuner design, hence an introductory note on recent receiver developments is in order.

For proper sound reception, receivers designed with separate video and sound if strips require a local oscillator which is stable enough to permit the converted sound carrier to pass through the narrow sound if amplifier and FM detector without distortion or loss of sound. This requirement imposes restrictions upon stability many times more severe than those normally obtainable with commercially available tubes and components. To maintain proper stability, either afc systems or highly refined oscillator circuits are customarily used. Many receiver manufacturers are now using the intercarrier sound system in which the sound modulation is taken from the 4.5 mc beat between the aural and visual carriers. (See

SYLVANIA NEWS, January 1949.) Small amounts of local oscillator drift are less noticeable with the intercarrier sound system, inasmuch as the 4.5 mc beat frequency containing the sound modulation is fixed at the transmitter. Due to the relaxed stability requirements, afc systems as well as special local oscillator refinements can be eliminated or simplified when the intercarrier sound system is used. This tends to simplify tuners and to reduce their cost.

Some manufacturers are changing from the conventional 24 mc if to 44 mc. Better image rejection plus the prospect of uhf channels are among the reasons for this trend to a higher if. (See SYLVANIA NEWS, September 1950.)

Tuner RF Input Circuits

Tuner rf input circuits have been subject to considerable development since the earliest tuners were marketed. Antenna systems currently available are designed for transmission lines ranging from 50 to 300 ohms characteristic impedance. Consequently, tuner

manufacturers have attempted to accommodate the many impedance variations of these antennas by various methods. The tapered line antenna coupling network is one example of such an input circuit. By the use of specially constructed, interwound inductances, this coupling network efficiently matches either 75 or 300 ohm transmission lines to the grid of the rf amplifier tube. Such a coupling network supplies a voltage gain from the antenna terminals to the rf amplifier grid, as well as minimizing the standing wave ratio on the transmission lines. The tuner pictured in Figure 1 utilizes a tapered line antenna input. The coils of the tapered line transformer are visible behind the tubes in the tuner.

Both antenna impedance and rf amplifier input impedance vary considerably between channels 2 and 13. The use of separate input transformers for low and high bands, with band switching automatically controlled by the channel selector, provides an approximate match between antenna and rf

(Continued on page T-38)

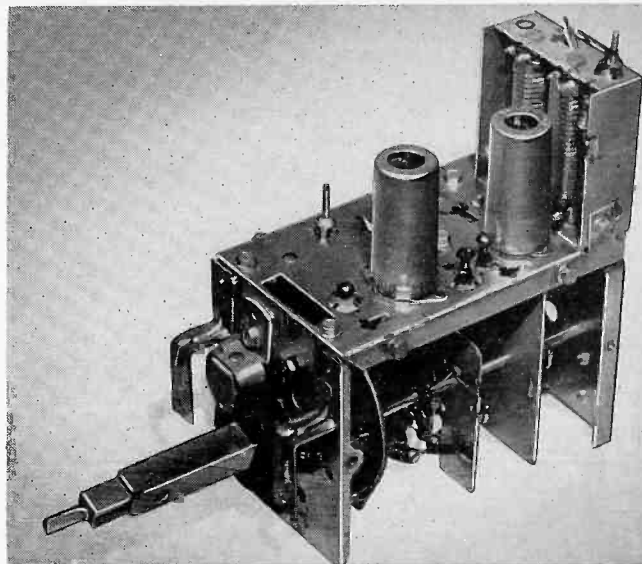

Figure 1. The Philco-Sickles tuner which switches a set of inductances across contact points for each channel. This model, utilizing a tapered line input transformer, is used in recent Philco models.

amplifier over the range of present television channels in some tuners.

Although tuners with a broadband coverage have not been popular, there is a possibility of interest developing for their use with the higher 44 mc if amplifiers in television receivers. Broadband tuners depend upon a reasonably flat rf response over the necessary range of channels, the tuning being accomplished by varying the local oscillator frequency. The number of critical tuning elements is therefore reduced. It is possible to design broadband tuners which perform favorably in comparison with more conventional tuners. Adjacent channel rejection must be accomplished in the if strips of receivers utilizing broadband tuners. One disadvantage of broadband tuners is the radiated local oscillator signal which can be a serious problem.

Mechanical Developments

Considerable development work has been done on television tuners, mechanically. Recent designs tend to be very compact and have simplified tuning mechanisms. Smaller tuners provide the set manufacturer with more flexibility in chassis layout and cabinet styling than would be practical with bulky units. Simpler tuner mechanisms result in fewer field complaints and are more easily serviced. The reduction in tuner size has been obtained partially by the elimination of obsolete circuits, by using more effective circuits which require fewer parts, and by using the available space more efficiently. In fact,

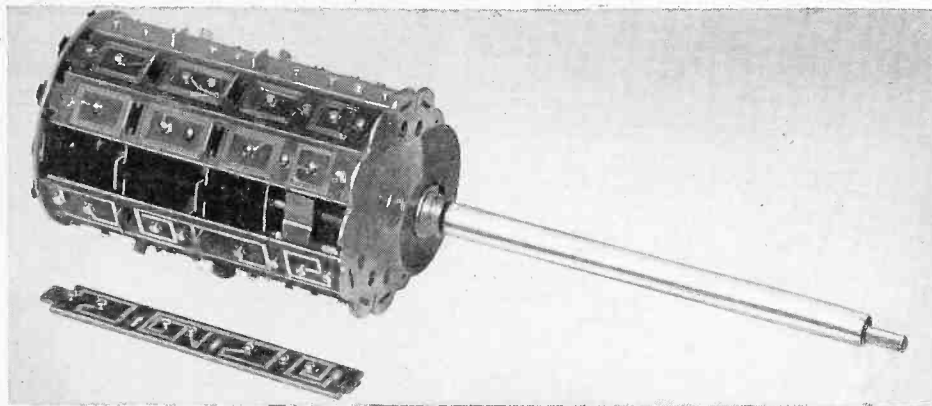

some units such as those shown in Figures 2 and 4 are more easily serviced than earlier models. The turrets shown in these pictures, for example, may be detached from the tuner assembly by the removal of three springs. Either turret can be further disassembled by the removal of the coil strip for any channel as illustrated. It can be seen that replacement of such a coil strip can be readily accomplished. Many tuners also have test points brought out to aid in alignment.

When separate sound and video if channels are employed, microphonism requirements for the tuner are extremely severe. Slight vibrations of either the oscillator tube or components can cause frequency variations in the local oscillator. These frequency variations appear at the output of the FM sound detector as ringing noises. To reduce vibrations and their effects, tuners are usually shock mounted on the receiver chassis. To further reduce vibrations of the oscillator tube, some manufacturers

Figure 2. Turret assembly of the RCA-Victor printed circuit tuner used by Hallcrafters. Note the ease with which a strip may be replaced.

have placed a heavy leaden shield over it, the mass of this shield being sufficient to dampen the vibrations of the tube. In sets which use the intercarrier sound system, the sound is no longer dependent upon the oscillator frequency remaining fixed, but upon the 4.5 mc carrier beat as discussed previously. Therefore, the frequency variations of the oscillator caused by vibrations do not appear at the output of the FM detector. For these reasons the microphonism requirements are materially reduced in sets employing the intercarrier sound system. In such receivers the shock mounting paraphernalia has been eliminated resulting in a simpler mechanical design.

Continuous tuning is employed in many of today's television tuners with various combinations of band-switching arrangements as desired by a set manufacturer. Thus one tuner operates continuously from 54 through 216 mc including the FM band. Another tuner switches from one television band covering channels 2 through 6 to the other band covering channels 7 through 13 automatically when the channel selector reaches a predetermined point in its travel. Still other tuners have manual band switching arrangements. Either variable inductance or capacitance can be used to accomplish continuous tuning. Figure 3 shows an example of continuous tuning with a manually operated band switch.

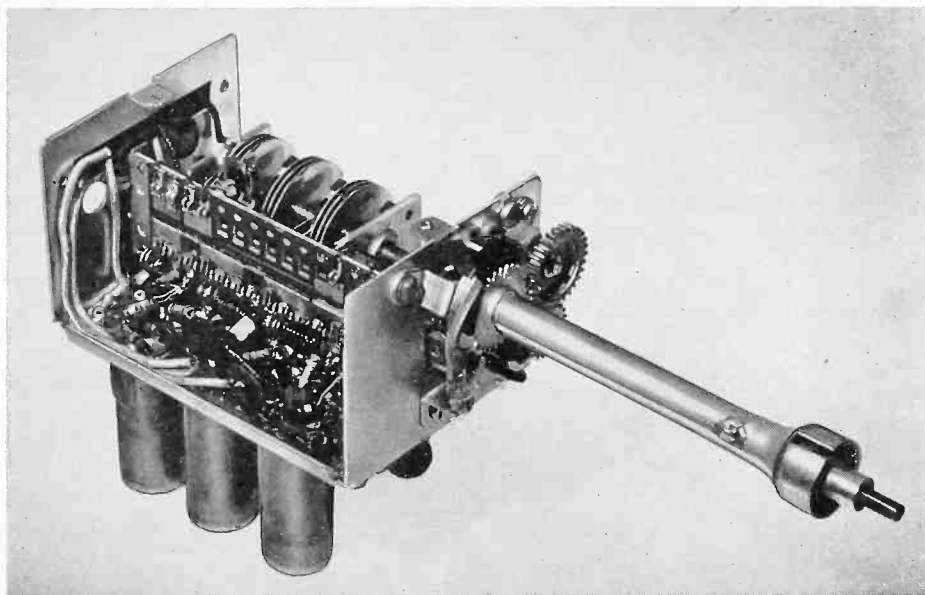

Figure 3. The General Instruments two band tuner used in Sylvania Movie Clear Television receivers. Continuous tuning across the lower band and upper band channels is featured, with a band change switch selecting the range desired.

Figures 2 and 4 show good examples of vernier tuning arrangements utilizing a variable dielectric principle. Other vernier tuning methods include schemes for varying the capacitance in the oscillator circuit by changing the spacing or effective area of condenser plates. Continuous type tuners, of course, require no electrical vernier tuning arrangement.

Turret assemblies were among the first tuner designs. Recent turret type tuners, as shown in Figure 4 permit more efficient, shorter connections. They also permit reception on all channels which was not possible on some of the earlier designs. One version of the turret type tuner is the use of printed circuits for the coils. Figure 2 shows a partially disassembled turret using printed coils. The printed circuit is produced by a photo-etch process. It is claimed that this construction is less susceptible to microphonism and permits more uniformity in the manufacture of tuners.

Tube Developments

The earliest tuners were designed around the tubes then available, but which were not necessarily the best tubes possible for this sort of application. Manufacturers now employ tubes with higher transconductance and less loading which provide for higher efficiencies in tuners. Physically, the trend has been from the larger lock-in and octal based tubes to the miniature types. In addition to the advantages gained by the small size of these tubes, they also offer better high frequency performance as required by tuners because of the lower lead inductances of such tube designs. Still more recently, sub-miniature tubes applicable to tuners have been announced and are under consideration by tuner manufacturers.

Test Equipment

In the early days of television, sweep generators, oscilloscopes and marker generators were expensive and generally regarded as laboratory equipment rather than essential servicing equipment for tuner alignment. Servicemen attempted to realign tuners, as well as if strips, by using a signal generator and vacuum-tube voltmeter. This procedure frequently resulted in improper operation. Service equipment manufacturers have designed

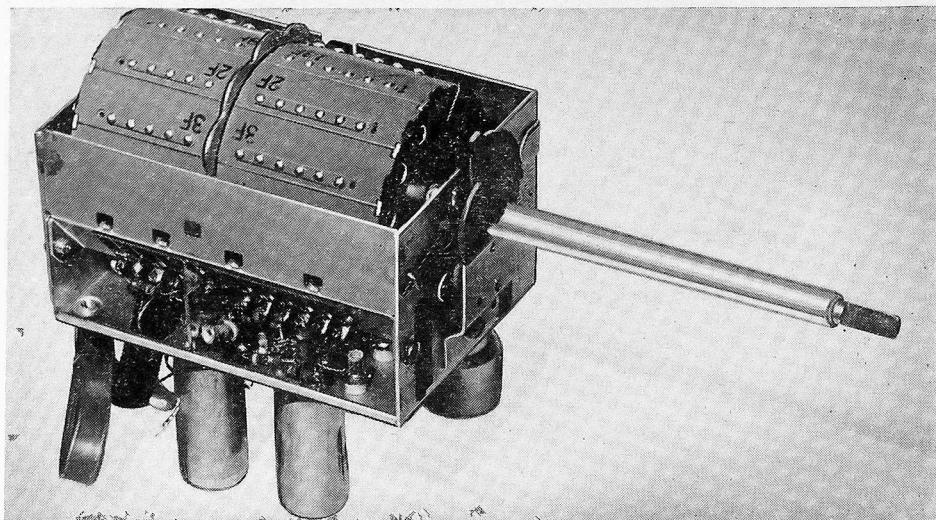

Figure 4. One of the most popular turret type tuners is the one made by Standard Coil which also features removable coil strips. Concentric chafts provide coil switching and vernier tuning. The vernier tuning cam is visible at the front of the assembly. This model is found in many receivers including Admiral, Hoffman and Magnavox.

and are today producing relatively inexpensive sweep and marker generators and oscilloscopes which greatly facilitate proper alignment of the tuner. These instruments are now regarded as essential to television servicing.

When the first television channels were assigned, it was believed that reception beyond fifty miles would be impractical due to the curvature of the earth as well as other natural obstacles. It was also believed that if transmitted power were strong enough to reach this distance, the signal to noise ratio would present no problem. Conforming with these beliefs, few attempts were made to build high gain video if amplifier strips into the first receivers. Furthermore, no special efforts were made to design tuners with low noise factors. After a short time, it became apparent that fringe area reception was possible over a larger radius. The tuner noise factor established a limit for the use of better if amplifiers. The trend in tuners has been toward an improved signal to noise ratio.

As the number of television receivers in any area increases, interference due to local oscillator radiation becomes a serious problem. Some tuner manufacturers have used effective shielding along with an rf amplifier stage between the oscillator and the antenna to reduce such radiation.

UHF And Color Television

Some television sets available on

the market today have provisions for UHF. Space is available in these sets for the addition of a tuner for UHF reception. Power and signal sockets to accommodate such tuners are also usually available. There is at least one turret type tuner, however, which has circuits incorporated in a channel strip. This channel strip can replace one of the unused strips already in the tuner and will enable the receiver to operate in the UHF region.

To date color television has been more of a problem in scanning requirements than in tuner considerations. The CBS color system currently under discussion needs no added bandwidth for existing channel operation, hence the tuner requirements for the reception of such systems are not materially altered.

Future design trends in television tuners are unpredictable at the moment due to the uncertainties which still exist with regard to the proposed UHF channels. These designs will probably be largely influenced by further attempts to incorporate UHF operation into tuners. Such designs will be greatly dependent upon developments in circuitry, tubes and components which are still in the experimental stages. It is expected that these developments will provide inexpensive, yet stable and efficient tuners to cover all parts of the radio spectrum allocated to commercial television.

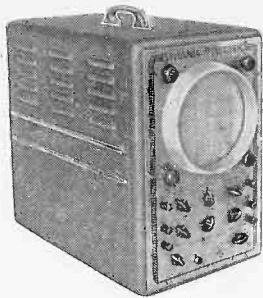

TEST EQUIPMENT CORNER

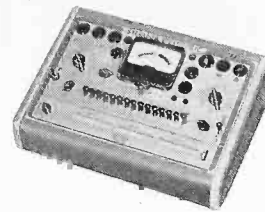

New Settings For Type 139-140 Tube Testers

Users of the Sylvania Type 139 and 140 Tube Testers will be interested in the following revised test settings. These are additions to the latest roll chart No. 15845E. The number may be found in the lower left hand corner of the chart. If your tube tester does not contain this latest chart, it may be purchased from the Advertising Department, Sylvania Electric Products, Inc., Emporium, Pennsylvania. The price is \$1.00 postpaid.

Type	A	B	C	D	E	F	G	Test
2E24	6.3	0	356	0	8	024	23	Y
2E26	6.3	0	36	0	8	024	25	Y
	"	"	56	0	8	024	25	Y
	"	"	53	0	8	024	25	Y
3V4	2.5	2	45	4	1	016	45	U
6BY5G	6.3	0	—	0	2	—	19	Y
	"	"	—	0	3	—	19	Y
12AV7	12.6	0	5	0	1	3	35	U
	"	"	"	"	3	7	35	U
812(A)	6.3	0	—	0	8	3	35	W
866(A)	2.5	0	—	0	8	—	17	Y
5516	6.3	0	356	0	8	024	28	Y

Light Shield For Sylvania Oscilloscopes

When noise pulses are suspected, say on the pass band curve used for TV alignment, it is desirable to be able to see these pulses on the cathode ray oscilloscope screen. The electron beam travels at much higher speeds in tracing these sharp pulses. The total energy delivered to the fluorescent material during such sharp transient pulses must be spread over a larger surface, meaning that the brightness of any part of the high speed transient will be much less than the brightness of slow speed portions of the trace. In short, pulses appear as fine, hair-like "grass" because the beam is moving so rapidly.

If a strong overhead light shines directly onto the face of the tube, its surface may be illuminated more from this light than it is from the electron beam inside the tube. Viewing the thin-lined pulses becomes difficult simply because the external other light being reflected is brighter than the trace. One obvious way to facilitate seeing these pulses is to shade the oscilloscope screen by using a light shield.

The sketch shown is a pattern for such a light shield to fit the Sylvania seven-inch 'scopes, such as models

400 and 132Z. The material may be a piece of sheet metal such as a one-gallon tin can or a five-quart motor oil can. Surface reflection from the metal should be prevented by finishing it with dull black paint. The material used for the sample was an ordinary heavy green desk

blotter with a little Scotch tape used at the overlapped joint. If metal is used, soldering or riveting is desirable. The finished shield fits tightly inside the rubber bezel around the seven-inch tube face and may be easily turned to facilitate viewing from any angle.

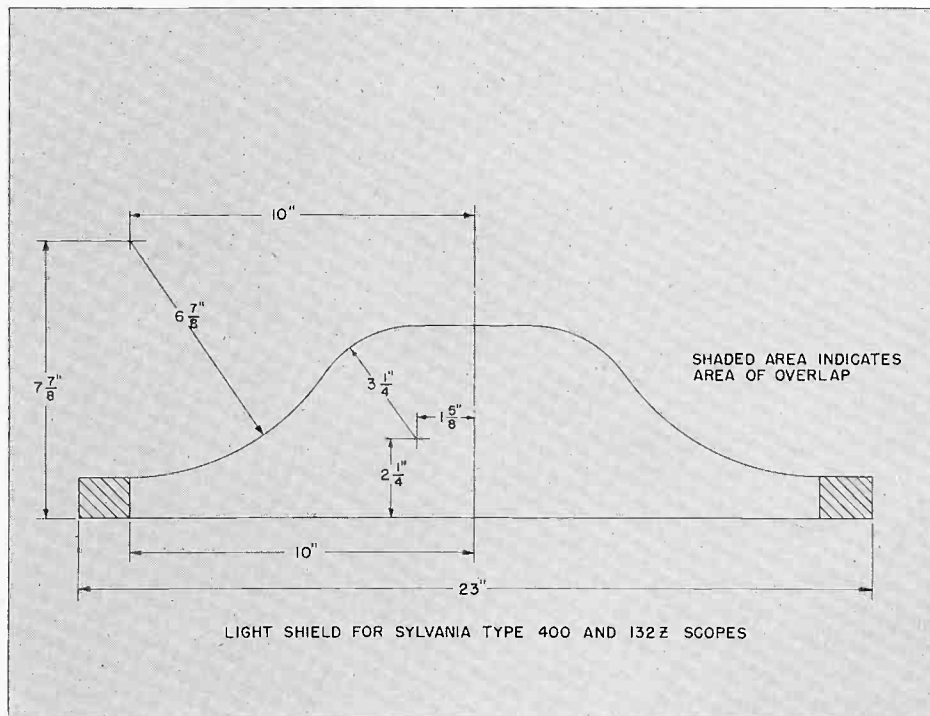

Portable Television Antenna Aids Set Sale . . . Assures Better Installation

Upstate New York Dealer
Finds Mobile Tower Useful
And Valuable in Sale and
Service of Television Sets

The coming of television has brought with it many new things. Service dealers in television areas have been required to make bigger and bigger investments in equipment to better handle the problems of television service. This is especially true in fringe areas where signal strength is low and additional accessories are required to receive an acceptable picture.

Typical of one type of sales and service accessory equipment required in some areas is the traveling antenna truck of George Rock of Cadyville, N. Y. This truck, on which an antenna is mounted, is used to determine the proper position for the best signal and can be used to demonstrate the performance of a set to a prospective customer in his own home.

The antenna tower used by Rock is of his own design. By using a ten foot mast, it can be raised to a height of 75 feet. The tower is strong enough to handle any size antenna in winds up to sixty-five miles an

hour without the aid of guy wires or blocking on the truck.

It is also possible for the truck to be driven to various locations for use in probing while the tower is raised to a height of 45 feet. In constructing the tower on the truck Rock designed the tower to use a twenty foot length of two inch diameter magnesium pipe, to extend the height to 85 feet where necessary.

When not in use, the tower is lowered and positioned on the roof of the truck. Raising the tower by means of a wrench allows handling by one man.

An investment in equipment such as that used by Rock represents one of the new problems facing television technicians. The days of the "screwdriver mechanic" are rapidly ending. The rise in television and associated installation and service requires the service dealer to invest greater amounts of money in equipment, if he is to give satisfactory service to the growing number of television set owners.

Below is the truck used by George Rock, Cadyville, N. Y. for his portable television antenna. The antenna, shown at the right, will extend to a height of eighty-five feet. Such equipment is used for signal probing and demonstrations in customers homes.

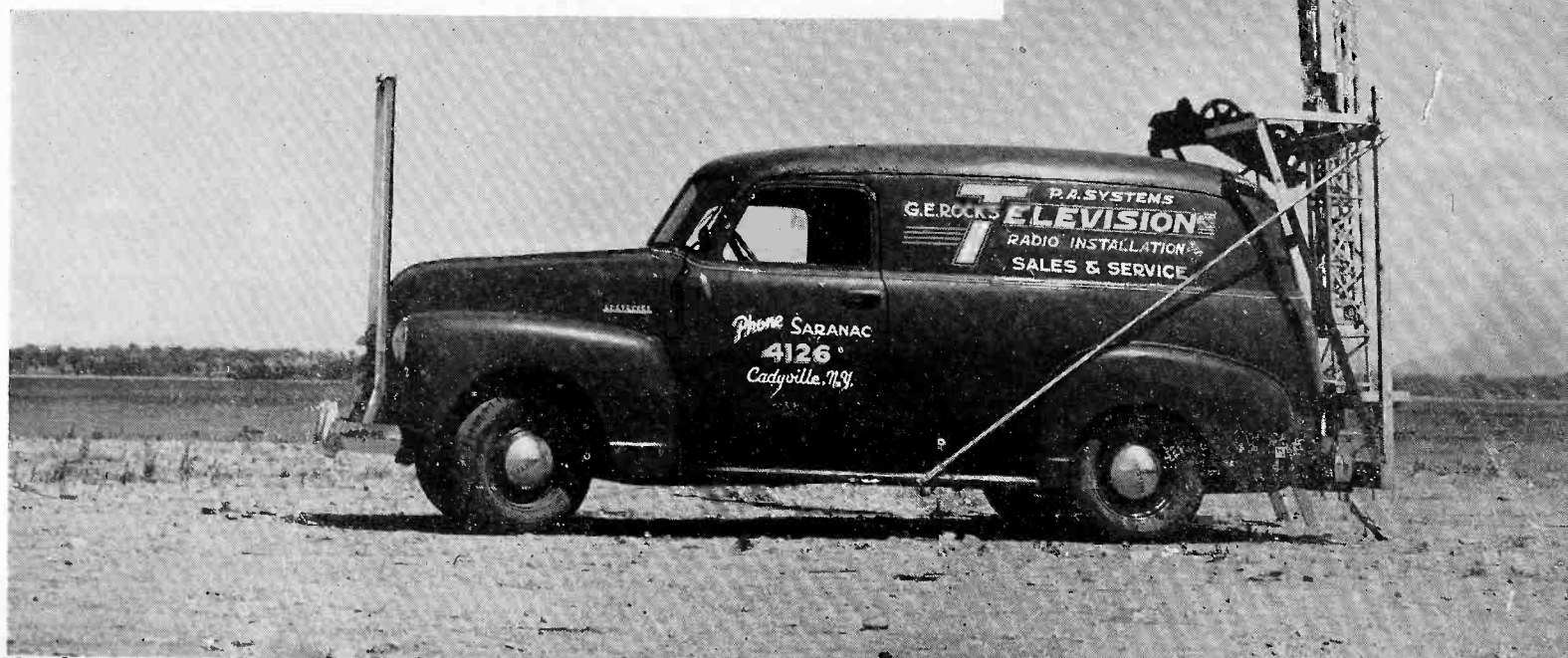

Profits Come With Pen and Ink

(Continued from page M-37)

Fixtures & Equipment" is a record of money paid for material purchased on an installment plan or money paid to a bank for money borrowed. In general, entries in this column are for capital expenditures — expenditures, which add to the value of your business. Interest on money borrowed from a bank, or paid on the purchase of equipment should not appear here, but in the "Expense" record under "Interest."

In the "Cash Balance for Month" column there is a condensed picture of the financial standing of the business for the month. This column will show what financial progress has been made and where the weak spots of the operation were for the month. This record helps to keep expenses in line and helps increase profits.

Part Two of the monthly record shows how much money was spent for merchandise during the month. This should only include money paid out for merchandise which was later resold. It does not include the payment for merchandise which is used in normal business operation such as speaker cement, wire, and other material not chargeable directly to the customer.

Here too, is a record of payments made to employees, as salary and

wages. This record also includes the amount of money withheld for Old Age Benefits and Income Tax collected for the Government.

There is a complete record like the one described above for every month of the year. Each month is an individual record which shows the financial picture in complete detail.

To complete the yearly financial

record, The Sylvania Business Record Book contains a yearly "Profit and Loss Statement." From the material gathered during the year, this statement can be prepared with little difficulty. This statement shows the condition of your business at year's end and is a good indication of how well you did and where the weak spots are.

The book also contains many helpful suggestions for determining your income tax. It shows how the forms should be prepared and tells what each item in the tax form stands for.

Business records are essential to any business. Through adequate records of yesterday, there is better planning for tomorrow. The Sylvania Business Record Book offers an economical system for keeping records of expenses and profits. The cost of the book is \$1.00. No matter whether you do \$10,000 or \$100,000 worth of business every year you'll find this system valuable.

Start the new year on firm ground by obtaining a copy of the Sylvania Business Record Book. Keep it daily and watch it help your profits increase. Order today from your Sylvania Distributor, or the Advertising Department, Sylvania Electric Products Inc., Emporium, Pa.

The price is \$1.00.

IMPORTANT FEATURES

Contained in Sylvania's
BUSINESS RECORD

1. Day by Day and Week by Week record of all money taken in.
2. Week by Week record of all money paid out.
3. Daily record of Payments for Merchandise.
4. Complete Payroll record—record of Personal Drawings.
5. Record of Payments on Notes, Furniture and Equipment.
6. A monthly Summary of your Cash Balance.
7. A Complete Yearly Summary by months of all the above items.
8. A simple, easy to figure, Profit and Loss Statement for the year.
9. Easy to follow instructions on how to fill out "Profit or Loss" Schedule of your Income Tax Return the following year.
10. Tax Calendar and record of Tax Payments.
11. Record of Bad Debts charged off during the year and Schedule of Depreciation.

Tells you in easy-to-understand language how to keep this simple Record and shows by actual specimens where to enter your daily and weekly figures.

Week by Week INCOME Record for the Month of January 1955

DAY	1/1	2/1	3/1	4/1	5/1	MONTHLY TOTAL OF INCOME BY WEEK
SUNDAY	12.00	12.00	12.00	12.00	12.00	60.00
MONDAY	12.00	12.00	12.00	12.00	12.00	60.00
TUESDAY	12.00	12.00	12.00	12.00	12.00	60.00
WEDNESDAY	12.00	12.00	12.00	12.00	12.00	60.00
THURSDAY	12.00	12.00	12.00	12.00	12.00	60.00
FRIDAY	12.00	12.00	12.00	12.00	12.00	60.00
SATURDAY	12.00	12.00	12.00	12.00	12.00	60.00
SUNDAY	12.00	12.00	12.00	12.00	12.00	60.00
OTHER INCOME						
TOTAL	174.00	174.00	174.00	174.00	174.00	1044.00

Week by Week EXPENSE Record for Month

DAY	1/1	2/1	3/1	4/1	5/1	MONTHLY TOTAL OF EXPENSES BY WEEK
SUNDAY	12.00	12.00	12.00	12.00	12.00	60.00
MONDAY	12.00	12.00	12.00	12.00	12.00	60.00
TUESDAY	12.00	12.00	12.00	12.00	12.00	60.00
WEDNESDAY	12.00	12.00	12.00	12.00	12.00	60.00
THURSDAY	12.00	12.00	12.00	12.00	12.00	60.00
FRIDAY	12.00	12.00	12.00	12.00	12.00	60.00
SATURDAY	12.00	12.00	12.00	12.00	12.00	60.00
SUNDAY	12.00	12.00	12.00	12.00	12.00	60.00
OTHER EXPENSES						
TOTAL	174.00	174.00	174.00	174.00	174.00	1044.00

PAYMENTS ON NOTES, FIXTURES & EQUIPMENT

DATE	AMOUNT	BY	REMARKS
1/1/55	100.00	Bank	Payment on Note
1/15/55	50.00	Bank	Payment on Note
1/31/55	20.00	Bank	Payment on Note
TOTAL	170.00		

CASH BALANCE FOR MONTH

DATE	BALANCE	INCOME	EXPENSES	BALANCE
1/1/55	100.00			100.00
1/31/55	100.00	1044.00	1044.00	100.00
TOTAL	100.00	1044.00	1044.00	100.00

111 SYLVANIA TUBES GIVE EXCELLENT PERFORMANCE

Above is a sample page showing Part I of the Sylvania Business Record. This page is a complete record of income and expenses for one month. Cash balance sheet shows financial standing at end of month.

Payments for MERCHANDISE for the Month of January 1955

DATE	PAID TO	AMOUNT	PAID TO	AMOUNT
1/1/55	Electronics	20.00		
1/15/55	Radio Parts	15.00		
1/20/55	Radio Parts	10.00		
1/25/55	Radio Parts	10.00		
1/30/55	Radio Parts	10.00		
TOTAL FOR MONTH		65.00		

PAYROLL RECORD

DATE	EMPLOYEE	TOTAL	TOTAL
1/1/55	John Doe	100.00	100.00
1/15/55	John Doe	100.00	200.00
1/31/55	John Doe	100.00	300.00
TOTAL FOR MONTH		300.00	300.00

CASH THIS MONTH TOTAL PAID TO MERCHANDISE TOTAL FOR MONTH

IT PAYS TO SELL SYLVANIA

Above is a sample page from Part II of the Business Record. This is a record of all merchandise purchased during the month. Included too is a record of payroll payments to employees with tax and social security data.

Defense Restrictions Threaten Cutbacks By Set Makers

Civilian production by the radio and television industry will be cut next year because of shortages of vital materials. Under orders issued by the National Production Administration supplies of aluminum, nickel, copper, zinc and cobalt for civilian use will be reduced.

Industry leaders have estimated that set and parts reductions of between 20% and 30% will be necessary because of the scarcity of these materials.

Most serious problem facing the manufacturers was the NPA order which removed cobalt from the list of materials available for civilian production. Cobalt is vital to the production of alnico magnets, essential in speaker production. Without cobalt the industry would have to use inferior permanent magnet speakers.

To relieve this condition, the NPA released a directive which said "It will be necessary to develop some long term method for conservation and allocation of this material. Some immediate needs for both defense and civilian uses are pressing, however, an interim measure

Al White Made Technical Speaker

H. Allen White formerly associated with the Geophysical Instrument Development Laboratories, Magnolia Petroleum Co., Dallas, Texas, has been appointed sales service engineer for the Radio Tube Division of Sylvania according to R. W. Andrews, merchandising manager.

Andrews said that White, who holds a second class commercial radio telephone license and owned and operated his own radio and television service shop for several years, will conduct technical meetings for radio and television servicemen under the joint sponsorship of Sylvania Electric and its distributors.

must be adopted to provide minimum supplies for these needs."

The NPA said its directive provides that orders other than defense orders, shall be filled by delivering to each purchaser 30% of the average monthly quantity which he received during the first six months of 1950.

Restrictions of other critical materials for civilian use by the NPA have not been as heavy as those put on cobalt, but they will have some effect on receiver production next year.

The resourcefulness of the industry can, however, be counted on to develop new methods of manufacturing and conservation of vital materials for greatest production and efficiency without sacrificing quality in the products it produces.

Court Blocks Color TV Start

The question of commercial color television is still up in the air. First broadcasts were scheduled to begin on November 20, but the Federal Court in Chicago has temporarily restrained the Columbia Broadcasting System from beginning broadcasts on that date.

The restraining order will remain in effect until the court has reached a decision on an application filed by RCA for a temporary injunction. Both the FCC and CBS have filed motions asking for dismissal of the application.

No indication was given for the length of time required by the court to reach a decision. The panel of three judges hearing the case stated that, "No one can expect this court to render any kind of a decision today, tomorrow or next week. It is unthinkable that the court give a decision at once in view of the importance and complications of this issue. The court will decide as soon as it can—we've got a lot of studying to do—a lot of reading to do."

Meanwhile, CBS continues its

Storm Damages Radio-TV Facilities

The big storm which swept the eastern part of the country over the Thanksgiving weekend caused considerable damage to television antennas and forced some radio broadcasters off the air.

Television set owners in the Metropolitan New York area were hit when more than 50% of the nearly 3,000,000 antennas were blown down or damaged.

Set owners, according to the New York Better Business Bureau, were attempting to seek antenna adjustments under their service contracts. Most contracts, according to the BBB contain a clause exempting the service company from responsibility "due to damage or loss from fire, water, windstorm, lightning and any other so-called 'acts of God.'" In such cases, said the BBB customers cannot morally or legally expect service companies to repair or replace such antennas without incurring additional charges.

closed circuit showing of its color television system in New York. Generally, reception to color television has been favorable, but disappointment has been expressed by many viewers at the small screen size.

Large Screen Picture Tubes Most Used

Television picture tubes 16 inches and larger accounted for 87% of those sold to receiver manufacturers in September. During the month, set makers and distributors bought 813,688 picture tubes for use in new equipment and for replacement of worn-out tubes. Rectangular picture tubes accounted for approximately 54% of the number of picture tubes sold. Most popular size tube used by manufacturers was the 16 and 17 inch rectangulars which accounted for nearly 45% of all tubes sold.

New Book Lists Data For Tube Substitution

The Radio Tube Division of Sylvania Electric Products Inc. has just announced the release of its latest aid to radio servicing—the Sylvania Tube Substitution Manual. Under current industry conditions, frequent difficulty is encountered in obtaining direct tube replacements. The Sylvania Substitution Manual helps you find a substitute tube type—tells you what physical or electrical changes are necessary to use it.

This 40-page book gives substitution data for over 300 popular radio and television tubes, tabulated in convenient, easy-to-read listings in the six major categories. Included are extensive sections on television receiving types and television picture tube types. There is also a complete classification chart which lists tube types by categories according to their principal functions. Other data includes tube adapter wiring diagrams and an important article on substitutions in a series filament type receiver.



Here's an aid to servicing you can't afford to be without—and, best of all, it's yours without charge. Visit your Sylvania Distributor and ask him for your copy of the Sylvania Tube Substitution Manual. (Also available from Advertising Department, Sylvania Electric Products Inc., Emporium, Pa.)

Facts & Figures...

Industry Sets New TV Production Rate in October

Production of television receivers during October was at an all-time record rate, according to estimates compiled by the RTMA. The weekly average of sets produced was 203,462 receivers making the total monthly production 813,851. This brings the total number of sets produced this year to 5,777,610.

Radio set production during October also continued high. Total production including home, auto and portable sets for the month was 1,413,563. For the first ten months of 1950 the total production of radio sets has been 11,481,823.

Receiving Tube Sales Reach All-Time High

Sales of receiving tubes for radio and television reached an all-time high in October according to latest reports by the RTMA. October tube sales to manufacturers and distributors numbered 40,105,611. This compares to 24,353,631 tubes sold in the corresponding month last year, which was also the record month for that year.

Of the tubes sold in October, 32,305,648 were for use in new equipment; 6,699,448 were sold as replacement tubes and 182,177 were sold to the government. October sales brought the total number of tubes sold in the first ten months of 1950 to 304,910,357.

SYLVANIA NEWS

SYLVANIA ELECTRIC PRODUCTS INC.
P. O. BOX 431
EMPORIUM, PENNA.

Sec. 3486, P. L. & R.
U. S. POSTAGE
PAID
Permit No. 1
Emporium, Pa.

For

David E. Zarim
1408 Downing St. N. E.
Washington 18, D. C.

A

POSTMASTER: IF UNDELIVERABLE FOR ANY REASON, NOTIFY SENDER, STATING REASON, ON FORM 3547, POSTAGE FOR WHICH IS GUARANTEED.

Vol. 17, No. 10

DECEMBER, 1950

PUBLISHED BY
SYLVANIA ELECTRIC PRODUCTS INC.

MANUFACTURERS OF SYLVANIA RADIO TUBES, CATHODE RAY TUBES, ELECTRONIC DEVICES, FLUORESCENT LAMPS, FIXTURES, WIRING DEVICES, ELECTRIC LIGHT BULBS, PHOTOLAMPS, RADIO AND TELEVISION RECEIVERS

In This Issue

NEWS
THE TUBE SHORTAGE

MERCHANDISING
PROFITS COME WITH
PEN AND INK

TECHNICAL
NEW DEVELOPMENTS
IN TELEVISION TUNERS