

WALL CONNECTOR, 80A SINGLE PHASE INSTALLATION MANUAL

THIS MANUAL IS OF THE HIGHEST IMPORTANCE

Approved Markets: North America, Japan



About this Manual.....	2
Communications Regulations.....	2
Errors or Inaccuracies.....	2
Copyrights and Trademarks.....	2

Safety Information.....	3
Important Safety Instructions.....	3
Warnings.....	3
Cautions.....	3
Notes.....	4

Specifications.....	5
---------------------	---

Features.....	6
Optional Circuit Ratings.....	6
Self-Monitoring and Recovery.....	6
Power Outages.....	6
Load Sharing.....	6

Planning Your Installation.....	7
Minimum Requirements.....	7
Service Wiring.....	7
120V Above Ground.....	7
Ground Connection.....	7
240V Single-Phase.....	7
208V 3-Phase Wye-Connected.....	8
240V Three-Phase Delta-Connected.....	8
277V Three-Phase Wye-Connected.....	9
Determine the Circuit Breaker Requirements.....	10
Choose the Best Location for the Wall Connector.....	10
Installation Considerations.....	11

Check the Box Contents.....	13
-----------------------------	----

Step-by-Step Installation

Instructions.....	15
Tools and Materials Required.....	15
Overview of Installation Steps.....	15
Install the Low Profile Bracket for Rear or Bottom Entry Wiring.....	16

Install the Top Entry Bracket for Top Entry Wiring.....	17
Prepare for Installation.....	18
Connect the Wiring.....	19
Set the Operating Current.....	21
Secure the Cover and Power Up.....	22

Troubleshooting.....	23
Reset.....	26
Questions?.....	27

Appendix A: Testing for Proper Operation.....	28
--	----

Appendix B: Optional Connection for Load Sharing..	29
Daisy Chaining Multiple Wall Connectors.....	29
Example of the Communication Wiring.....	30

Charging Equipment Limited Warranty.....	31
General Terms.....	31
Limits of Liability.....	32
Warranty Enforcement Laws and Dispute Resolution.....	32



Communications Regulations

This device complies with Part 15 of the FCC rules and Industry Canada license-exempt RSS standard(s). Operation is subject to the following two conditions: (1) This device may not cause harmful interference and (2) this device must accept any interference received, including interference that may cause undesired operation.

⚠ Important: Changes or modifications to this product not authorized by Tesla could void the FCC compliance.

Errors or Inaccuracies

To communicate any inaccuracies or omissions, or to provide general feedback or suggestions regarding the quality of this manual, send an email to:

ownersmanualfeedback@teslamotors.com

Copyrights and Trademarks

All information in this document is subject to copyright and other intellectual property rights of Tesla Motors, Inc. and its licensors. This material may not be modified, reproduced or copied, in whole or in part, without the prior written permission of Tesla Motors, Inc. and its licensors. Additional information is available upon request. The following are trademarks or registered trademarks of Tesla Motors, Inc. in the United States and other countries:

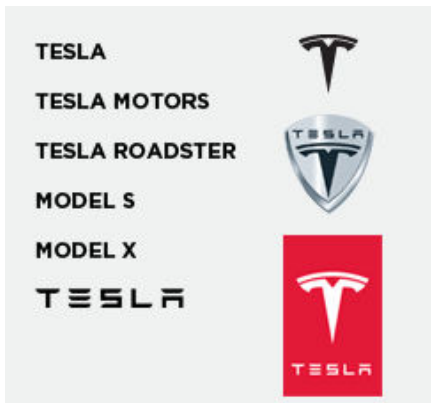











All other trademarks contained in this document are the property of their respective owners and their use herein does not imply sponsorship or endorsement of their products or services. The unauthorized use of any trademark displayed in this document or on the vehicle is strictly prohibited.







Important Safety Instructions



This document contains important instructions and warnings that must be followed when installing and maintaining the Wall Connector.

Warnings

-  Warning: Read all the instructions before using this product.
-  Warning: This device should be supervised when used around children.
-  Warning: The Wall Connector must be grounded through a permanent wiring system or an equipment grounding conductor.
-  Warning: Do not install or use the Wall Connector near flammable, explosive, harsh, or combustible materials, chemicals, or vapors.
-  Warning: Turn off input power at the circuit breaker before installing or cleaning the Wall Connector.
-  Warning: Use the Wall Connector only within the specified operating parameters.
-  Warning: Never spray water or any other liquid directly at the wall mounted control box. Never spray any liquid onto the charge handle or submerge the charge handle in liquid. Store the charge handle in the dock to prevent unnecessary exposure to contamination or moisture.
-  Warning: Stop using and do not use the Wall Connector if it is defective, appears cracked, frayed, broken, or otherwise damaged, or fails to operate.
-  Warning: Do not attempt to disassemble, repair, tamper with, or modify the Wall Connector. The Wall Connector is not user serviceable. Contact Tesla for any repairs or modification.
-  Warning: When transporting the Wall Connector, handle with care. Do not subject it to strong force or impact or pull, twist, tangle, drag, or step on the Wall Connector, to prevent damage to it or any components.

-  Warning: Do not touch the Wall Connector's end terminals with fingers or sharp metallic objects, such as wire, tools, or needles.
-  Warning: Do not forcefully fold or apply pressure to any part of the Wall Connector or damage it with sharp objects.
-  Warning: Do not insert foreign objects into any part of the Wall Connector.
-  Warning: Use of the Wall Connector may affect or impair the operation of any medical or implantable electronic devices, such as an implantable cardiac pacemaker or an implantable cardioverter defibrillator. Check with your electronic device manufacturer concerning the effects that charging may have on such electronic devices before using the Wall Connector.

Cautions

-  Caution: Do not use private power generators as a power source for charging.
-  Caution: Incorrect installation and testing of the Wall Connector could potentially damage either the vehicle's Battery and/or the Wall Connector itself. Any resulting damage is excluded from the New Vehicle Limited Warranty and the Charging Equipment Limited Warranty.
-  Caution: Do not operate the Wall Connector in temperatures outside its operating range of -22°F to 122°F (-30°C to +50°C).



Notes

Note: Ensure that the Wall Connector's charging cable is positioned so it will not be stepped on, driven over, tripped on, or subjected to damage or stress.

Note: Do not use cleaning solvents to clean any of the Wall Connector's components. The outside of the Wall Connector, the charging cable, and the connector end of the charging cable should be periodically wiped with a clean, dry cloth to remove accumulation of dirt and dust.

Note: Be careful not to damage the circuit boards or components during installation.



The maximum power rating for the Wall Connector is 20 kW or 80A at 250V AC single-phase power. Your vehicle can charge from 200V to 277V single-phase power.

Description	Specifications
Voltage and Wiring	277V AC single-phase: L1, neutral, and earth 208V or 240V AC single-phase: L1, L2, and earth
Current	Maximum output: 80A, 72A, 64A, 56A, 48A, 40A, 36A, 32A, 28A, 24A, 20A, 16A, 12A
Frequency	50 to 60 Hz
Cable Length	8.5' (2.6 m) and 24' (7.4 m)
Wall Connector Dimensions	Height: 15.0" (380 mm) Width: 6.3" (160 mm) Depth: 5.5" (140 mm)
Top Entry Bracket Dimensions	Height: 10.8" (275 mm) Width: 15.1" (130 mm) Depth: 2.0" (50 mm)
Weight (including bracket)	20 lb (9 kg)
Operating Temperature	-22°C to 122°C (-30°C to 50°C)
Storage Temperature	-40°F to 185°F (-40°C to 85°C)
Enclosure Rating	Type 3R
Agency Approvals	cULus listed for United States and Canada under file number E354307, FCC Part 15.



Optional Circuit Ratings

Use a single-phase circuit breaker rated for 100A per phase to obtain the fastest charging. In certain installation locations, this level of power isn't readily available. Therefore, you can adjust the circuit breaker rating on the Wall Connector from 15A to 100A (refer to Set the Operating Current on page 21).

Note: Tesla vehicles must be configured with optional onboard charging equipment to accept higher amperages. Contact Tesla if you have questions about the onboard charging capabilities of your vehicle.

Self-Monitoring and Recovery

The Wall Connector has a ground monitoring circuit that continuously checks for the presence of a safe ground connection and automatically recovers from faults. Manual testing and resetting is not required.

Temporary problems such as ground faults or utility power surges are overcome automatically. If a residual current fault occurs that interrupts charging, the Wall Connector automatically tries to clear the fault and re-attempt charging.

If the problem is immediately sensed a second time, the Wall Connector waits 15 minutes before trying to charge. This process repeats 4 times and if all attempts are unsuccessful, power is removed and no further attempts are made. In this case, you will see a red error light on the front panel (refer to Troubleshooting on page 23). It is recommended that when you see a red error light, you power off the Wall Connector by switching off the upstream circuit breaker, and then power it back on again.

The Wall Connector can alternatively be reset when a red error light is encountered using the RESET button (refer to Reset on page 26).

Power Outages

If a power outage occurs, the Wall Connector automatically resumes charging when power is restored. If the charging cable is plugged into the vehicle when power is restored, the lights blink and the unit does not energize the charging cable for approximately 15 seconds to three minutes. This prevents the utility grid from experiencing a large surge when power is restored and allows vehicles to begin drawing current at random times, rather than all at once.

Load Sharing

The Wall Connector provides the capability to wire 4 Wall Connectors to a single circuit, giving vehicle owners reassurance that they can charge multiple vehicles at home (refer to Appendix B: Optional Connection for Load Sharing on page 29).



Minimum Requirements

Installation of the Wall Connector requires that you:

- Calculate the existing electrical load to determine the maximum operating current.
- Calculate the distance to ensure minimal voltage drop.
- Obtain any necessary permits from the local authority that has jurisdiction and confirm that the follow-up inspection has been scheduled by an electrician after the installation is complete.
- Use only copper conductors.
- Use conductors that are sized in accordance with local wiring regulations. The selected cable must be able to sustain periods of constant load of up to 80A.
- Use protective devices. The circuit protection device chosen must incorporate a suitable residual-current device (RCD) and overcurrent protection in relation to the electrical load selected.

Note: Consult with an electrician to ensure that the installation meets local regulations.

Service Wiring

120V Above Ground

- Warning:** The Wall Connector is a single-phase device. Do not connect all three phases of a three-phase feed.
- Warning:** Before installing the Wall Connector, identify the type of utility service connection available on site. If you are unsure about the type of connection available at the service panel, consult an electrician, or contact Tesla for assistance.
- Caution:** The two phases used must each measure 120V to neutral. Earth ground must be connected to neutral at only one point, usually at the breaker panel.
- Caution:** If a 240V three-phase feed is from a Delta-connected secondary, the leg used must have a center tap. This center tap must be grounded. Only the two phases on either side of the center-tapped leg can be used.

Only three wires are connected, but care must be taken that the service transformer secondary connection is definitely known, and that the three wires from the main circuit breaker panel are correctly connected and labeled. The illustrations shown are the most commonly used wiring formats.

Note: The L1, L2, and ground outputs labeled on the illustrations correspond to the inputs on the Wall Connector.

Ground Connection

Always connect the Neutral at the service to Earth Ground. Ground fault protection is not possible unless the Neutral (center tap on the service transformer) is connected to an Earth Ground. If ground is not provided by the electrical service, you must install a grounding stake nearby. The grounding stake must be connected to the ground bar in the main breaker panel, and Neutral connected to Ground at that point.

240V Single-Phase

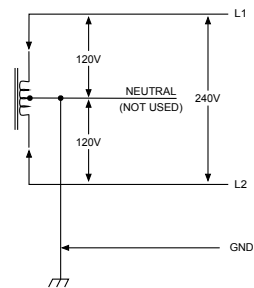

Note: Illustrations in this document are for demonstration purposes only.





208V 3-Phase Wye-Connected

With a Wye-connected secondary, any two of the legs can be used to provide 208V to the Wall Connector. For example, L1 and L2, or L1 and L3, or L2 and L3. The two used phases must each measure 120V to neutral.

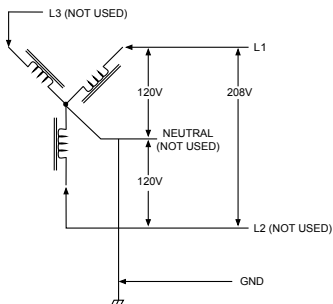
Note: A current-carrying neutral is not required.



-  **Caution:** The unused leg (L3 in the illustration) must remain open. Do not connect to a neutral bar, or to earth ground.
-  **Caution:** The center point of the three phases (normally used as neutral) must be grounded to earth at only one point. This is usually at the breaker panel.



240V Three-Phase Delta-Connected

With the delta connection, one leg must be center tapped, and only the two phases on either side of the center tap can be used. The two used phases must each measure 120V to neutral.

Consult the transformer manufacturer's literature to verify that the single leg can supply the required power.

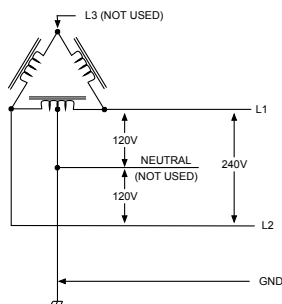
Note: The Wall Connector's contactor closes only if it detects the presence of an earth ground wire connected to a neutral point on the transformer secondary.





-  **Caution:** The third line (L3 in the illustration) of the delta is 208V, with respect to neutral, and is sometimes referred to as a "stinger." Do not use this third line.
-  **Caution:** Do not use a three-phase delta-connected transformer secondary without a center tap on one leg. No neutral point is available for the required earth ground connection.

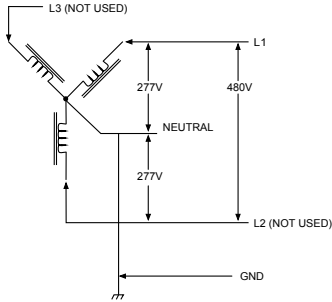

277V Three-Phase Wye-Connected

With a Wye-connected secondary, any leg along with neutral can be used to provide 277V to the Wall Connector. For example, L1 and N, or L2 and N, or L3 and N.



-  **Caution:** The unused legs (L2 and L3 in the illustration) must remain open. Do not connect to neutral or to earth ground.
-  **Caution:** The center point of the three phases (normally used as neutral) must be grounded to earth at only one point. This is usually at the breaker panel.



Determine the Circuit Breaker Requirements

To determine the type of upstream circuit breaker you need, examine the distribution panel or circuit breaker box to identify the amperage available at the installation site.

The Wall Connector has an internal rotary switch that allows you to adjust its operating current (refer to Set the Operating Current on page 21). The circuit breaker should be rated for the continuous current of: 12, 16, 20, 24, 28, 32, 36, 40, 48, 56, 64, 72, and 80A.

Choose the Best Location for the Wall Connector

Determine the parking location of the vehicle to ensure that the charge cable reaches the charge port.

- In an enclosed garage, typically on the vehicle's charge port side.
- In a well-ventilated area. Avoid installation in an enclosed box, or adjacent to hot appliances.

Note: The Wall Connector is approved for outdoor use. Protection from rain is recommended but not required.



Installation Considerations

Three methods are available to install the Wall Connector. The location of the conduit determines which installation method to follow. If the conduit runs along the floor or low on the wall, use the bottom entry configuration. If the conduit comes from inside the wall, use the rear entry configuration. If the available conduit comes from the ceiling, use the top entry installation.

Note: Throughout the manual, "conduit" is used as the standard term for the protective tubing that houses the service wiring. In regions where conduit is not used (Europe for example), a cable comprised of service wiring enclosed in a protective jacket may be substituted for conduit if allowed by local regulations.

Here are some additional guidelines:

- Conduit openings are sized for 1" (25 mm) conduit.
- Conduit needs to be metal and flame retardant.
- Use an appropriate circuit breaker.
- To keep the housing weatherproof, use cable glands.
- Use a UL approved conduit hub, Eaton HUB3 or equivalent is recommended.

Bottom or Rear Entry





Top Entry





The shipping box contains parts for all installation methods, as well as this manual. If any parts are damaged or missing, contact Tesla (refer to Questions? on page 27).

Note: Not shown is the supplied cardboard template.

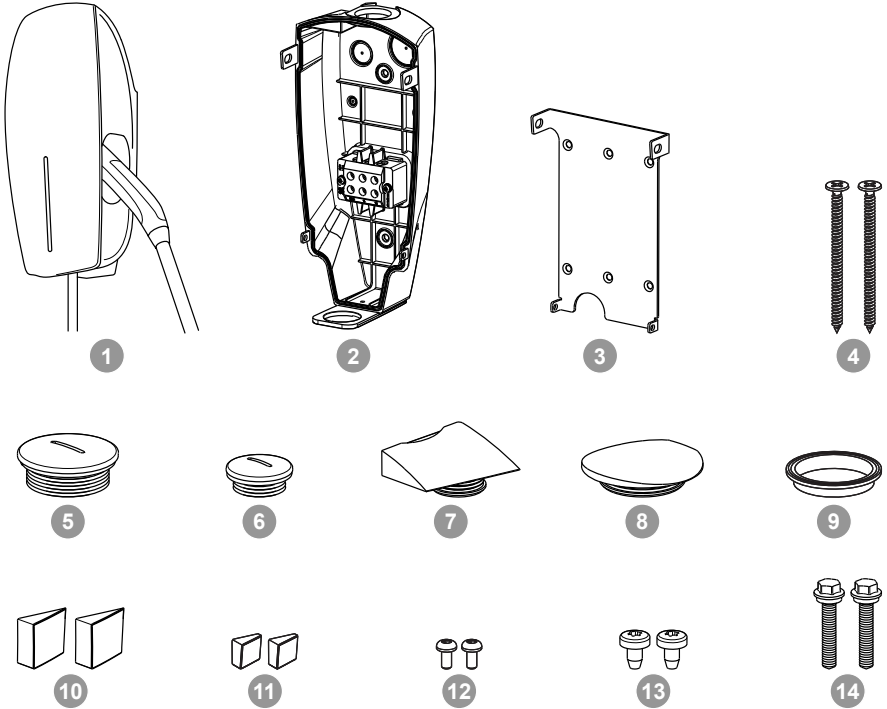

Item	Description (Quantity)
1	Wall Connector
2	Top entry bracket*
3	Low profile bracket **
4	Low profile bracket screws (2) **
5	Bottom or rear entry power conduit plug
6	Bottom or rear entry signal conduit plug
7	Top entry signal conduit plug*
8	Top entry power conduit plug*
9	Bottom conduit sealing gasket*
10	Top bracket-to-housing screw covers (2)
11	Bottom bracket-to-housing screw covers (2)



Item	Description (Quantity)
12	Bottom bracket-to-housing screws (2)
13	Top bracket-to-housing screws (2)
14	Top entry bracket mounting screws (2)*
* Items used in only top entry installations. ** Items used in only bottom or rear entry installations.	



Tools and Materials Required

Before installing the Wall Connector, gather the following tools and materials:

- Pencil or marker
- Hole punch (optional, to push through cardboard template)
- Wire stripper
- Voltmeter or digital multimeter (to measure AC voltage at the installation site)
- Phillips screwdriver
- Small flathead screwdriver
- Large flathead screwdriver (optional, to remove plastic knock-outs)
- T20 security pin Torx driver
- T10 Torx driver
- M20 and M32 cable glands (also known as sealing hubs)
- Ferrules (the diameter of the ferrule depends on the diameter of the power wiring and the construction)
- Wiring (use twisted pair communication cable, for a maximum of 49 ft (15 m) between Wall Connectors)

Note: Tesla recommends that you use a shielded cable to limit potential interference.

- Level
- Machine drill

Overview of Installation Steps

⚠ Warning: After you run service wiring to the installation site using metal flame retardant conduit, install the appropriate upstream circuit breaker, **TURN OFF AND VERIFY POWER IS OFF BEFORE CONTINUING.**

Then follow these steps to install the Wall Connector:

- Install the Low Profile Bracket for Rear or Bottom Entry Wiring on page 16
- Install the Top Entry Bracket for Top Entry Wiring on page 17
- Prepare for Installation on page 18
- Connect the Wiring on page 19
- Set the Operating Current on page 21
- Secure the Cover and Power Up on page 22



Install the Low Profile Bracket for Rear or Bottom Entry Wiring

Use the low profile bracket, shown below, to wire the Wall Connector from the rear or bottom.



1. Use the low profile bracket as a guide to mark the location on the wall for the mounting screws.
 - Use a level to ensure that the marks are perfectly vertical.
 - Space the holes 4.5" (114 mm) apart.

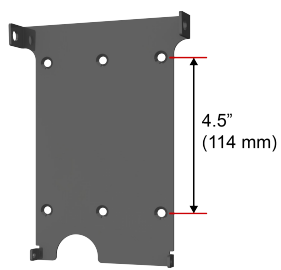

- For U.S.A. installations, position the bracket so that the Wall Connector is located at a maximum of 60" (150 cm) from floor level. The minimum height is 18" (45 cm) if mounting indoors, and 24" (60 cm) if mounting outdoors.

- If using rear entry conduit, use at least one set of the edge mounting holes so that the conduit does not interfere with the wall stud.
- If using bottom entry conduit, use the center two mounting holes.

Note: Ensure that the minimum and maximum height of the bracket is carefully selected. It should be installed out of the way of any reasonably foreseeable impacts.

2. Attach the bracket using fasteners that are appropriate for the type of wall material, drilling pilot holes if necessary. Use the supplied screws only if mounting the bracket directly to a wooden stud. If mounting to another type of wall (hollow, masonry, etc.), use fasteners that are long enough to securely anchor the Wall Connector and can hold at least 80 lb (36 kg).

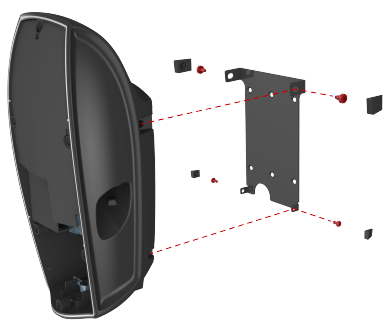



Install the Top Entry Bracket for Top Entry Wiring

The top entry bracket enables you to route the service wiring into the Wall Connector enclosure from the top of the enclosure, as shown below.



1. Use the cardboard template and a level as a guide to mark the location on the wall for the mounting screws.

- Use a level to ensure that the marks are perfectly vertical.
- Space the holes 6.1" (155 mm) apart.
- Position the bracket so that the Wall Connector is located at a maximum of 60" (150 cm) from floor level. The minimum height is 18" (45 cm) if mounting indoors, and 24" (60 cm) if mounting outdoors.

Note: Ensure that the minimum and maximum height of the bracket is carefully selected. It should be installed out of the way of any reasonably foreseeable impacts.

2. (Optional) There are two additional mounting holes. To use these holes, use a flat-head screwdriver to knock-out the plastic that is closing the holes. These holes are spaced 2.75" (70 mm) apart.

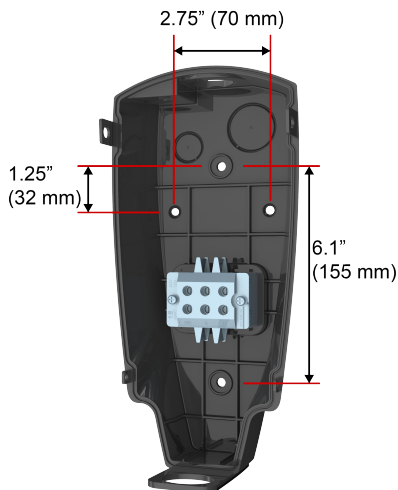

3. Attach the bracket using fasteners that are appropriate for the type of wall material, drilling pilot holes if necessary. Use the supplied screws only if mounting the bracket directly to a wooden stud. If mounting to another type of wall (hollow, masonry, etc.), use fasteners that are long enough to securely anchor the Wall Connector and can hold at least 80 lb (36 kg).

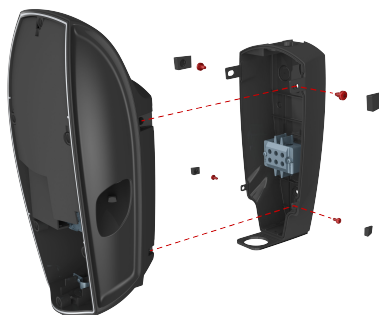



Prepare for Installation

Follow these instructions to remove the cover and route the service wiring into the Wall Connector.

1. Use a T10 Torx driver to remove the screw at the bottom of the outer cover. Carefully disengage the snaps on the sides and top using a flathead screwdriver and completely remove the cover. Save the screw and cover for reassembly.



2. Use a T20 security pin Torx driver to remove the six screws on the sealing cover. Carefully remove the sealing cover and disconnect the ribbon cable. Save the screws and cover for reassembly.

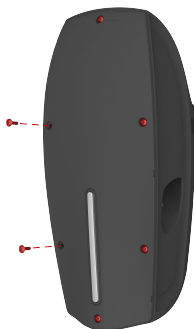

⚠ Caution: Do not allow the sealing cover to hang from the ribbon cable. Doing so can damage the ribbon cable or its connectors.

3. For top entry configuration, install the wiring to the terminal block in the top entry bracket as shown in Connect the Wiring on page 19, then return to this section and proceed to the next step. For back or bottom entry configurations, skip to the next step.
4. Place and hold the Wall Connector on the bracket, ensuring that all four mounting tabs are properly aligned.
5. Use a T20 Torx driver to install the two top housing mounting screws. Push the cosmetic screw covers into place.
6. Use a T20 Torx driver to install the two bottom housing mounting screws. Push the cosmetic screw covers into place.

Connect the Wiring

Note: Consult with your local electrician or refer to your local code for proper wire sizing appropriate for the currents in your Wall Connector.

Note: It is the installer's responsibility to identify whether additional grounding is required to ensure that local regulations are met. Grounding must be installed at the power source and not at the cable entry to the Wall Connector.

⚠ Warning: Do not connect service wiring until you have read and fully understand the concepts described in Service Wiring on page 7. If you are uncertain about the type of power available at the service panel, consult an electrician, or contact Tesla for assistance.

1. Turn off the power.

⚠ Warning: RISK OF ELECTRIC SHOCK! Before continuing, use a voltmeter to ensure the power is off by confirming that NO VOLTAGE is present at the service wiring or terminals.

2. For top entry installation, pull the service wiring into the top entry bracket or the Wall Connector. Use a 1" (25 mm) cable gland to seal the power conduit or cable. For 80A operation, use 2AWG 194°F (90°C) rated copper wire or follow local regulations.

Note: The meaning of wiring colors might vary from country to country. Follow all applicable national and local regulations concerning wiring color codes.

The following illustration shows an example of the wiring for the top entry bracket.

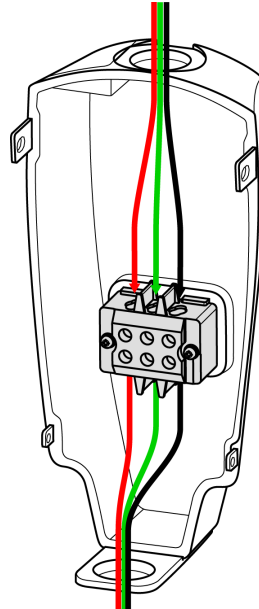

The following illustration shows an example of the wiring for the low profile bracket.

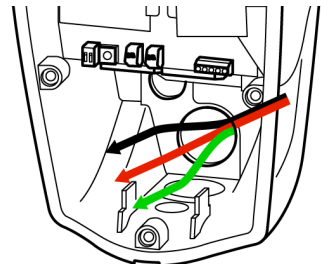

3. Strip the service wires going to the terminal block on the top entry bracket 3/4" (18 mm). Ferrules are recommended.

Note: For top entry installation, the flexible pre-installed wires that go from the top entry bracket to the housing are already terminated and do not need to be stripped.



4. Lead the preconnected service wires in the main housing 3/8" (10 mm) and connect the preconnected service wires to the terminal block with L1 (or line), L2 (or neutral), and ground wires going to the locations shown in the following illustration.

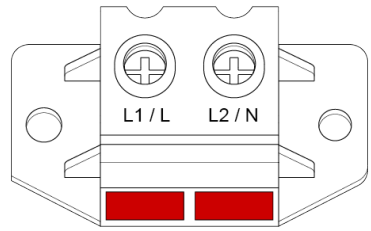

⚠ Caution: Cut each of the wire strands and insert them fully into each the terminal block.

Note: To ensure proper operation, verify that neutral is connected to the neutral line inside the circuit breaker box or the main electrical panel.

5. Tighten the terminal block to the recommended torque:
 - 35 in-lb (4.0 N-m) for the terminal block on the top entry bracket.
 - 33 in-lb (3.8 N-m) for the terminal block in the main housing.
 - 18 in-lb (2.0 N-m) for the ground terminal block in the main housing.
6. Check for miswiring using a multimeter and verify that there are no shorts before turning the upstream circuit breaker ON.



Set the Operating Current

Follow these instructions to configure the DIP switch. The following illustration shows an enlarged view of the DIP and rotary switches.

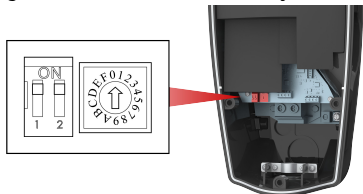

⚠ Warning: Power **MUST** remain OFF before setting or changing the DIP or rotary switches. Changing these switches with the power ON will not be recognized by the system and is dangerous due to the risk of electric shock.

1. Turn OFF power.
2. Use a non-conductive object (such as a plastic pen) to adjust the DIP switch settings:
 - Switch Position 1:
 - For a Line to Line connection (240V) set the DIP switch DOWN.
 - For an Line to Neutral connection (277V), set the DIP switch UP (the ON position).

⚠ Warning: Before you set the DIP switches, confirm which type of input service the utility provides.

- Switch Position 2:
 - DIP Switch Position 2 should always be in the UP position.

DIP Switch	Up (ON)	Down
Position 1	Line to Neutral (277V)	Line to Line (240V)
Position 2	Normal	Not Applicable

3. Set the rotary switch for the appropriate current setting supported by your circuit breaker. Typical circuit breaker ratings are: 15A, 20A, 25A, 30A, 35A, 40A, 45A, 50A, 60A, 70A, 80A, 90A, and 100A.

Use a small flathead screwdriver to adjust the rotary switch to the appropriate circuit breaker capability setting. The corresponding rotary switch settings for the typical circuit breakers are shown in the following table:

Rotary Switch Position	Maximum Output Current	Circuit Breaker
0	Test mode	N/A
1	12A	15A
2	16A	20A
3	20A	25A
4	24A	30A
5	28A	35A
6	32A	40A
7	36A	45A
8	40A	50A
9	48A	60A
A	56A	70A
B	64A	80A
C	72A	90A
D	80A	100A
E	Not a valid selection	N/A
F	Slave mode	N/A

4. Reattach the ribbon cable to the sealing cover.
5. Reinstall the sealing cover. Use a T20 security pin Torx driver to lightly secure the sealing cover by installing only the top screw.
6. Turn ON power.
7. If the installation is successful, the LEDs briefly sequentially illuminate green with a pattern that ends with the top green LED staying solid ON. If there is a solid or flashing red LED, refer to Troubleshooting on page 23 and resolve the error before you continue.



Note: To review the pattern of blinking lights, press and hold the RESET button for 5 seconds.

8. Turn OFF power.
9. Write the contact information of the installer on the label on the inside of the Wall Connector.

Note: To review the pattern of blinking lights, press and hold the Reset button for 5 seconds.

6. Attempt to charge the vehicle to ensure the Wall Connector is operating correctly and charging at the selected operating current. For instructions on how to charge, refer to the owner information provided with the vehicle.

Secure the Cover and Power Up

1. Use a T20 security pin Torx driver to install the remaining screws on the sealing cover. Ensure that the cover is properly aligned before fully tightening the screws.
2. Attach the outer cover to the sealing cover starting with the latch at the top. Engage the snaps on the sides and align the mounting tab with the housing at the bottom.



3. Use a T10 Torx driver to install the screw that secures the bottom of the outer cover to the housing.
4. Close any unused openings with power and signal conduit plugs.

Note: There should not be any visible openings to the inside of the Wall Connector, and the Wall Connector should be completely sealed from the environment.

5. Turn ON the power. The installation is correct if the LEDs go through a sequence of flashing, ending with the top Green LEDs staying solidly ON. If there is a solid or flashing Red LED, resolve the error before you continue (refer to Troubleshooting on page 23).



Green Lights	Yellow Light	Red Light	Auto-Retry	What it Means	What to Do
Top light on	Off	Off	Not applicable	Power on. The Wall Connector is powered and in standby but not charging the vehicle.	Not applicable.
Streaming lights	Off	Off	Not applicable	The Wall Connector is charging the vehicle.	Not applicable.
Streaming lights	1 flash	Off	Not applicable	Charging current is reduced due to high temperature detected in the Vehicle Connector.	Make sure the Vehicle Connector (charge handle) is fully inserted into the charge inlet in the car, is not covered by anything, and no heat source is nearby. If the problem continues with normal ambient temperatures (under 100°F or 38°C), contact Tesla.
Streaming lights	2 flashes	Off	Not applicable	Charging current is reduced due to high temperature detected in the wall plug or on the input terminals to the Wall Connector.	If a wall plug is used, make sure that it is fully inserted into the receptacle, it is not covered by anything, and no heat source is nearby. If the Wall Connector is wired directly to the wall source, make sure that the Wall Connector is not covered by anything, and no heat source is nearby. If the problem continues with normal ambient temperatures (under 100°F or 38°C), contact Tesla.
Streaming lights	3 flashes	Off	Not applicable	Charging current is reduced due to high temperature detected inside the Wall Connector.	Make sure the Wall Connector is not covered by anything and no heat source is nearby. If the problem continues with normal ambient temperatures (under 100°F or 38°C), contact Tesla.



Green Lights	Yellow Light	Red Light	Auto-Retry	What it Means	What to Do
Off	Off	1 flash	After 15 minutes and up to 4 times	Ground fault. Current is leaking through an unsafe path. Possible Line to ground or Neutral to ground fault.	Disconnect the handle from the car. Reconnect and try again. If the problem persists, turn OFF the circuit breaker servicing the Wall Connector and wait 10 seconds. Turn ON the circuit breaker and try again. If the problem persists, contact Tesla.
Off	Off	2 flashes	After 1 minute and up to 4 times	No ground connection detected in the Wall Connector.	Make sure the Wall Connector is properly grounded. If uncertain, consult your electrician for proper grounding at your circuit breaker or power distribution box and for proper connection to the Wall Connector.
Off	Off	3 flashes	No	Input miswired: possibly Line and Neutral are swapped.	The input wiring between the wall power and the Wall Connector has been improperly installed. Consult your electrician.
Off	Off	4 flashes	After 1 minute and up to 4 times	Over or under voltage protection.	Consult your electrician for proper voltage on the circuit breaker that services the Wall Connector.
Off	Off	5 flashes	After 1 minute retry (no limit on retries)	Over current protection.	Turn down the charge current setting in the vehicle. If the problem persists and the attached vehicle is manufactured by Tesla, contact Tesla. If the problem persists and the attached vehicle is a non-Tesla vehicle, contact the original manufacturer.



Green Lights	Yellow Light	Red Light	Auto-Retry	What it Means	What to Do
Off	Off	6 flashes	After 1 minute retry (no limit on retries)	Pilot fault: The pilot level is incorrect	Plug the vehicle into another Wall Connector if possible or plug the vehicle into a Mobile Connector supplied with the vehicle; If the problem persists, contact Tesla.
Top light on	Off	1 flash	No	Over temperature protection (latch-off)	Make sure the Wall Connector, vehicle connectors, and wall plug (if used) are not covered by anything and there is no heat source nearby. If the problem continues with normal ambient temperatures (under 100°F or 38°C), contact Tesla.
Top light on	Off	2 flashes	No	Non-Tesla vehicle attempting connection to non-compatible input distribution.	Compatible input distributions are: single-phase distribution or 400V, three-phase distribution.
Top light on	Off	3 flashes	No	Incorrect rotary switch setting.	Consult your electrician.
Top light on	Off	4 flashes	Not Applicable	Circuit Breaker Sharing Network: More than one Wall Connector is set to Master.	Set one of the Wall Connectors to Slave.
Top light on	Off	5 flashes	Not Applicable	Circuit Breaker Sharing Network: More than three Wall Connectors are set to Slave.	Move one or more Wall Connectors to a different circuit and disconnect it from this Circuit Breaker Sharing Network.
Top light on	Off	6 flashes	Not Applicable	Circuit Breaker Sharing Network: The networked Wall Connectors have different maximum current capabilities.	Contact Tesla.



Green Lights	Yellow Light	Red Light	Auto-Retry	What it Means	What to Do
Off	Off	Solid red	No	Wall Connector hardware failure. Possible failures include the following: <ul style="list-style-type: none">• Contactor failed• Self test failed in CCID circuitry• Other possible hardware failures might be MCU, 3V3output, or the thermal sensor.	Contact Tesla.

Reset

If a fault causes a RED error light to illuminate or flash and the fault condition is corrected, you can use the RESET button to reset the Wall Connector to return to proper operation.



1. Press the RESET button for two to three seconds. When the top light changes from RED to GREEN, release the RESET button. In this reset method, the fault message is cleared but the Wall Connector is not forced to reboot.
2. In a rare situation, you might need to force the Wall Connector to reboot without recycling the input power. Press the RESET button for five seconds. When the top light changes from RED to GREEN, release the RESET button. The top light should continue to illuminate GREEN. If the light returns to flashing RED, the fault state has not been corrected.



Questions?

- United States and Canada:
 - charginginstallation@teslamotors.com
 - +1-650-681-6133
- Mexico
 - charging_mx@teslamotors.com
 - +1-877-798-3752



1. Turn OFF power.
 -  **Warning: RISK OF ELECTRIC SHOCK!** Before continuing, use a voltmeter to ensure the power is off by confirming that NO VOLTAGE is present at the service wiring or terminals.
2. Use a non-conductive object (such as a plastic pen) to adjust the DIP switches to the appropriate grid setting and circuit breaker sharing setting (refer to Set the Operating Current on page 21).
3. Use a small flathead screwdriver to set the rotary switch to position "0" to put the Wall Connector into Test Mode.
 -  **Warning: Power MUST remain OFF** before setting or changing the DIP or rotary switches. Changing these switches with the power ON will not be recognized by the system and is dangerous due to the risk of electric shock.
4. Reattach the ribbon cable to the sealing cover.
5. Use a T20 security pin Torx driver to lightly secure the sealing cover by installing only the top screw.
6. Turn ON the circuit breaker.
7. Watch for any Red LEDs to be ON after a sequence of LED display; if so, there is a fault in the installation.
8. Listen for the click of a contactor or relay closing and opening.
9. Watch for Green streaming LEDs (for 5 seconds).

LEDs will revert to top Green LED ON and Red LEDs flashing (3 times).

Note: To review the pattern of blinking lights, press and hold the Reset button for 5 seconds.
10. Turn OFF the circuit breaker.
11. Remove the sealing cover screw, sealing cover. Disconnect the ribbon cable.
 -  **Caution: Do not allow the sealing cover to hang from the ribbon cable.** Doing so can damage the ribbon cable or its connectors.
12. Reposition the rotary switch to the appropriate setting (refer to Set the Operating Current on page 21).
13. Reattach the ribbon cable to the sealing cover.
14. Replace all the screws and reinstall the outer cover (refer to Secure the Cover and Power Up on page 22).



The Wall Connector includes a feature whereby Wall Connector to Wall Connector communication allows you to split the maximum available load over a maximum of 4 Wall Connectors. The wire used for this local network must share the main power cable conduit or be housed in a separate conduit.

You can connect the Wall Connectors in series in a daisy chain configuration.

Note: Take additional precautions into consideration to prevent water ingress at the Wall Connectors when installing them outdoors.

Note: Consult with an electrician to ensure that the installation meets local regulations.

Daisy Chaining Multiple Wall Connectors

Each Wall Connector has one terminal block dedicated for the communication wiring as shown below. The left hand side of the terminal block is the input terminal and the right hand side the output terminal.

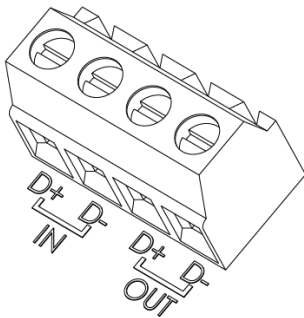

1. Form a daisy-chained network by connecting the cables from OUT to IN and

always from positive to positive and negative to negative between each of the participating Wall Connectors (refer to Example of the Communication Wiring on page 30).

- The signal wires between each Wall Connector should run in signal conduit. Use a 1/2" (13 mm) UL approved conduit hub to seal the signal conduit opening.
- If the signal wire is routed in the power conduit with the power wires, the insulation rating of the signal wire should be equal to or greater than that of the power wires.
- The maximum distance between Wall Connectors is 49 ft (15 m).
- Use twisted pair cable for the signal wire.

Note: Tesla recommends that you use a shielded cable to limit potential interference.

2. Set one Wall Connector as the master by setting the Rotary Switch Position from 1 to 8 depending on the maximum available output current. Set up to 3 Wall Connectors as slaves by setting the Rotary Switch Positions to F. In the load sharing network, only one unit can be designated as the master (refer to Set the Operating Current on page 21).
3. Confirm that the load sharing network is properly installed by observing the LED indicators in the Wall Connector. When starting up the circuit breaker for the first time, Green lights turning ON for 5 seconds indicate a proper installation as follows:

Green Lights	Yellow Light	Red Light	What it Means...
On (top and bottom)	Off	Off	Master unit
On (bottom)	Off	Off	Slave unit



Example of the Communication Wiring

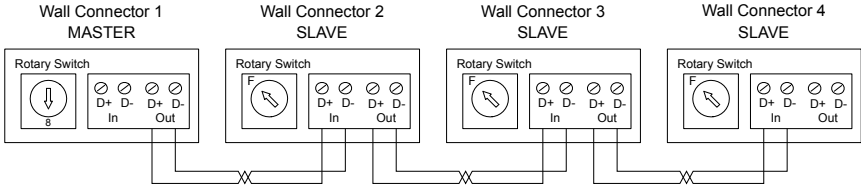



General Terms

Subject to the exclusions and limitations described below, the Charging Equipment Limited Warranty covers the refund, repair or replacement necessary to remedy any manufacturing defects in Tesla manufactured and supplied Wall Connector, Mobile Connector or charging adapter that occur under normal use for a period of 12 months from the date of invoice to the customer. Any Tesla connector or adapter included in the initial purchase and delivery of a Tesla vehicle by Tesla is covered under the Basic Vehicle Limited Warranty section of the New Vehicle Limited Warranty for 4 years or 50,000 miles (80,000 km), whichever comes first, subject to the terms and conditions of the New Vehicle Limited Warranty.

This Charging Equipment Limited Warranty does not cover any damage or malfunction directly or indirectly caused by, due to, or resulting from, normal wear or deterioration, abuse, misuse, negligence, accident, lack of or improper use, maintenance, storage or transport, including, but not limited to, any of the following:

- Failure to follow the instructions, maintenance and warnings published in the documentation supplied with your Tesla connector or adapter;
- External factors, including but not limited to, objects striking the Tesla connector or adapter, faulty or damaged electrical wiring, junction boxes, circuit breakers, receptacles or power outlets, the environment or an act of God, including, but not limited to, fire, earthquake, water, lightning and other environmental conditions;
- General appearance or damage to paint, including chips, scratches, dents and cracks;
- Failure to contact Tesla upon discovery of a defect covered by this Charging Equipment Limited Warranty;
- Any repair, alteration or modification to the Tesla connector or adapter or any part, or the installation or use of any parts or accessories, made by a person or facility not authorized or certified to do so;
- Lack of or improper repair or maintenance, including use of non-genuine Tesla accessories or parts; and
- Use for commercial purposes.

Although Tesla does not require you to perform all maintenance, service or repairs at a Tesla Service Center or Tesla authorized repair facility, this Charging Equipment Limited Warranty may be voided, or coverage may be excluded, due to lack of or improper maintenance, service or repairs. Tesla Service Centers and Tesla authorized repair facilities have special training, expertise, tools and supplies with respect to Tesla connectors and adapters and, in certain cases, may employ the only persons, or be the only facilities authorized or certified to work on Tesla connectors and adapters. Tesla strongly recommends that you have all maintenance, service and repairs done at a Tesla Service Center or Tesla authorized repair facility in order to avoid voiding, or having coverage excluded under, this Charging Equipment Limited Warranty.



Limits of Liability

This Charging Equipment Limited Warranty is the only express warranty made in connection with your Tesla connector or adapter. Implied and express warranties and conditions arising under applicable local laws, federal statute or otherwise, in law or in equity, if any, including, but not limited to, implied warranties and conditions of merchantability or merchantable quality, fitness for a particular purpose, durability, or those arising by a course of dealing or usage of trade, are disclaimed to the fullest extent allowable by your local law, or limited in duration to the term of this Charging Equipment Limited Warranty. To the fullest extent allowable by your local law, the performance of necessary repairs and/or replacement of new, reconditioned, or remanufactured parts by Tesla for the covered defects is the exclusive remedy under this Charging Equipment Limited Warranty or any implied warranties. To the maximum extent permissible under your local law, liability is limited to the reasonable price for repair or replacement of the applicable Tesla connector or adapter, not to exceed the manufacturer's suggested retail price. Replacement may be made with parts of like kind and quality, including non-original manufacturer's parts, or reconditioned or remanufactured parts, as necessary.

Tesla shall not be liable for any defects under this Charging Equipment Limited Warranty that exceed the fair market value of the applicable Tesla connector or adapter at the time immediately preceding the discovery of the defect. In addition, the sum of all benefits payable under this Charging Equipment Limited Warranty shall not exceed the price you paid for the applicable Tesla connector or adapter.

Tesla does not authorize any person or entity to create for it any other obligations or liability in connection with this Charging Equipment Limited Warranty. The decision of whether to repair or replace a part or to use a new, reconditioned or remanufactured part will be made by Tesla, in its sole discretion.

To the maximum extent permissible under local law, Tesla hereby disclaims any and all indirect, incidental, special and consequential damages arising out of, or relating to, the Tesla connector or adapter, including, but not limited to, transportation to and from a Tesla Authorized Service Center, loss of the Tesla connector or adapter, loss of vehicle value, loss of time, loss of income, loss of use, loss of personal or commercial property, inconvenience or aggravation, emotional distress or harm, commercial loss (including but not limited to lost profits or earnings), towing charges, bus fares, vehicle rental, service call charges, gasoline expenses, lodging expenses, damage to tow vehicle, and incidental charges such as telephone calls, facsimile transmissions, and mailing expenses.

The above limitations and exclusions shall apply whether your claim is in contract, tort (including negligence and gross negligence), breach of warranty or condition, misrepresentation (whether negligent or otherwise) or otherwise at law or in equity, even if Tesla is advised of the possibility of such damages or such damages are reasonably foreseeable.

Nothing in this Charging Equipment Limited Warranty shall exclude, or in any way limit, Tesla's liability, for death or personal injury solely and directly caused by Tesla's negligence or that of its employees, agents or sub-contractors (as applicable), fraud or fraudulent misrepresentation, or any other liability to the extent the same is proven in a court of competent jurisdiction in a final nonappealable judgment and may not be excluded or limited as a matter of local law.

Warranty Enforcement Laws and Dispute Resolution

To the fullest extent allowed by local law, Tesla requires that you first provide written notification of any manufacturing defect within a reasonable time, and within the applicable coverage period specified in this Charging Equipment Limited Warranty, and allow Tesla an opportunity to make any needed repairs before submitting a dispute to our dispute settlement program (described below). Please send written notification on dispute resolution to the following address:



United States:
Tesla Motors, Inc.
3500 Deer Creek Road
Palo Alto, California 94304
Telephone: 1-877-798-3752

Canada:
Tesla Motors Canada ULC
1325 Lawrence Avenue East
Toronto, ON M3A 1C6
Telephone: 1-877-798-3752

Please include the following information:

- Tesla connector or adapter invoice date;
- Your name and contact information;
- Name and location of the Tesla Store and/or Tesla Service Center nearest you;
- Description of the defect; and
- History of the attempts you have made with Tesla to resolve the concern, or of any repairs or services that were not performed by Tesla.

In the event any disputes, differences or controversies arise between you and Tesla related to this Charging Equipment Limited Warranty, Tesla will explore all possibilities for an amicable settlement. In case an amicable settlement is not reached, Tesla offers a dispute settlement program through:

NATIONAL CENTER FOR DISPUTE
SETTLEMENT (“NCDS”)
P.O. Box 526
Mt. Clemens, MI 48046
1-866-629-3204

Tesla requires that you submit your dispute to our dispute settlement program and wait for a decision to be issued prior to pursuing any remedy under federal or state laws (including 15 U.S.C. Section 2310 or California Civil Code Section 1793.22(b)), although you may be entitled to pursue a remedy without submitting under certain state laws or if you pursue any rights or remedies not created by these laws. This dispute settlement program administered by NCDS is free of charge to you and is conducted by local NCDS professionals who are trained and experienced in mediation and arbitration.

NCDS resolves disputes involving this Charging Equipment Limited Warranty which arise during the applicable warranty period specified in this Charging Equipment Limited Warranty. You must file a request for arbitration with NCDS within 60 days (or 6 months in certain jurisdictions) of the expiration of the applicable warranty period, provided you sent written notice to Tesla of the alleged defect was brought to the attention of Tesla during the applicable warranty period.

To initiate arbitration, you must contact NCDS at 1-866-629-3204 or P.O. Box 526, Mt. Clemens, MI 48046, and complete an NCDS customer claim form and mail it to NCDS. Please also provide a copy of your written notification sent to Tesla and/or all information required in such notification specified above, your desired resolution, and all receipts if requesting reimbursement. Upon receipt of your request, NCDS will contact you regarding the status of your case and provide you with additional details about the program.

When NCDS receives your request, it will be forwarded to Tesla for response. After analyzing all information pertaining to your case, NCDS will schedule a technical evaluation if applicable. If you request it, an oral hearing will be held prior to a decision being rendered. At this hearing, all evidence is admissible. After considering all testimony and documents, the arbitrator will review the applicable legal standards and render a decision. A settlement satisfactory to all parties may be negotiated at any time, including prior to or after the arbitrator’s decision.

NCDS’s decision is binding on Tesla but not on you. If you accept NCDS’s decision, Tesla will comply with the decision in a reasonable time not to exceed 30 days after Tesla receives notice of your acceptance. Remedies include but are not limited to repairs; reimbursement for repairs and incidental expenses, such as transporting costs; and repurchase or replacement of the applicable Tesla connector or adapter. NCDS decisions do not include attorney fees or punitive, multiple, or consequential damages, except incidental damages as required by applicable law. NCDS findings and decisions are admissible as evidence in any legal proceedings concerning the applicable Tesla connector or adapter.



The description provided above is only a brief summary of the dispute settlement program administered by NCDS. The dispute settlement program may be changed at any time without prior notice. Contact NCDS at the above listed address or phone number for the most current information concerning the dispute settlement program.



B

- bottom or rear entry
 - configurations, dimensions and spacing 11
 - example of the service wiring 19
 - installing the low profile bracket for 16

C

- cardboard template, using the 16
- cautions 3
- check the box contents 13
- circuit breaker
 - corresponding rotary switch settings 21
 - requirements 10
- circuit ratings, optional 6
- communications regulations 2
- conduit, about 11
- connect the wiring 19
- copyrights 2
- cover
 - removing the outer 18
 - removing the sealing 18
 - securing the outer 22

D

- dimensions 5
- DIP switches, configuring 21
- documentation errors, sending feedback 2

F

- features
 - circuit ratings, optional 6
 - load sharing 6
 - recovery from power outages 6
 - self-monitoring and recovery 6

I

- installation
 - for rear or bottom entry wiring 16
 - for top entry wiring 17
 - information, about 2
 - planning your 7
 - preparing for 18
 - tools and materials required 15
 - torque recommendations 19
- installation overview 15
- installation, testing 28

L

- lights, diagnostic 6
- lights, LED 23
- load sharing
 - about 6
 - configuring the DIP and rotary switches 21
 - example of the communication wiring 30
- low profile bracket
 - installing the 16

M

- minimum requirements 7

N

- notes 4

P

- planning your installation
 - circuit breaker requirements 10
 - location of the wall connectors 10
 - minimum requirements 7
 - service wiring 7
 - types of installations 11
- power outages, recovery from 6
- power ratings 5
- power up 22

R

- removing the outer cover 18
- reset button 6, 26, 28
- rotary switches, configuring 21

S

- safety instructions 3, 4
- securing the outer cover 22
- self-monitoring and recovery 6
- service wiring 7, 19
- set the operating current 21
- specifications
 - dimensions 5
 - power ratings 5
 - temperature limits 5



T

- temperature limits 5
- terminal blocks
 - connecting the service wiring to the 19
 - torque recommendations 19
- Tesla, contacting 27
- testing for proper operation 28
- top entry
 - bracket, installing the 17
 - configurations, dimension and spacing 11
 - example of the service wiring 19
 - wiring, installing the top entry bracket for 17
- trademarks 2
- troubleshooting 23, 26, 27, 29

W

- wall connectors
 - checking the box contents 13
 - connecting the terminal blocks 29
 - daisy chaining 29
 - example of the communication wiring 30
 - location of 10
 - optional configuration 29
 - power up 22
 - reset 26, 28
 - troubleshooting 29
- warnings 3
- wiring for load sharing 29



P/N: 1069742-00-A

MNL, USER GUIDE, NA, 1PH, 80A, HW, WC, GEN2



(P) PN: 1069742-00-A

(T) TLN: TT80AMP1NA